

MATLAB®

Function Reference

R2014a

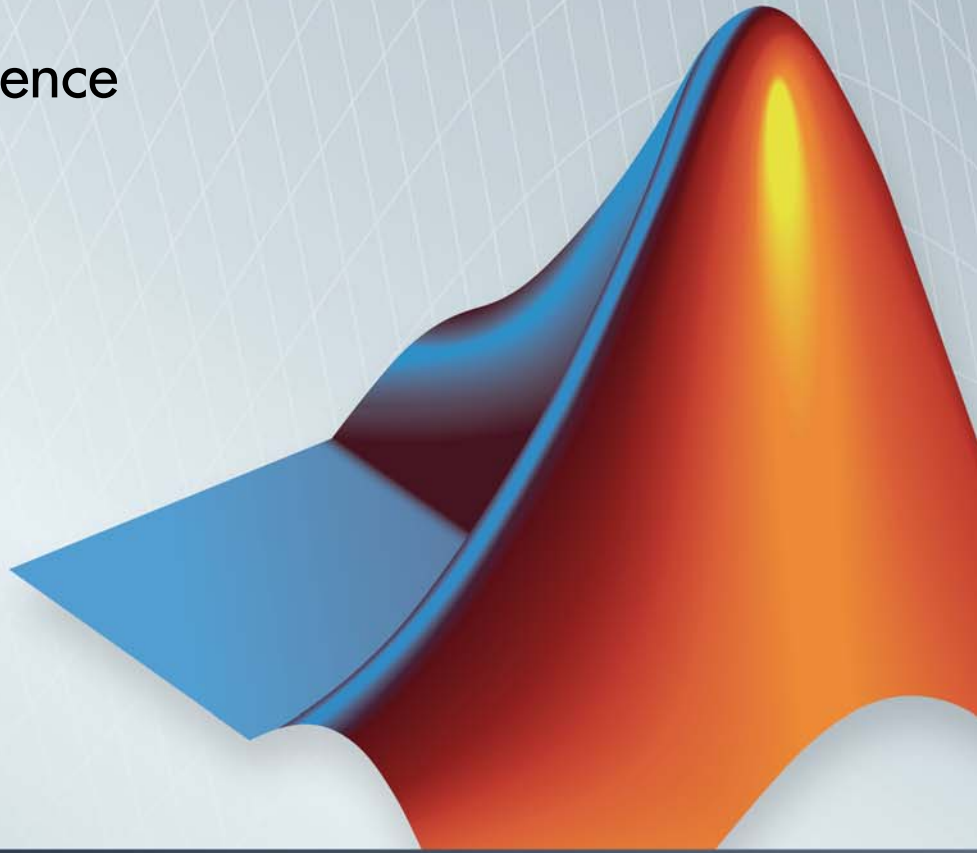

MATLAB®



How to Contact MathWorks



www.mathworks.com Web
comp.soft-sys.matlab Newsgroup
www.mathworks.com/contact_TS.html Technical Support



suggest@mathworks.com Product enhancement suggestions
bugs@mathworks.com Bug reports
doc@mathworks.com Documentation error reports
service@mathworks.com Order status, license renewals, passcodes
info@mathworks.com Sales, pricing, and general information



508-647-7000 (Phone)



508-647-7001 (Fax)



The MathWorks, Inc.
3 Apple Hill Drive
Natick, MA 01760-2098

For contact information about worldwide offices, see the MathWorks Web site.

MATLAB Function Reference

© COPYRIGHT 1984–2014 by The MathWorks, Inc.

The software described in this document is furnished under a license agreement. The software may be used or copied only under the terms of the license agreement. No part of this manual may be photocopied or reproduced in any form without prior written consent from The MathWorks, Inc.

FEDERAL ACQUISITION: This provision applies to all acquisitions of the Program and Documentation by, for, or through the federal government of the United States. By accepting delivery of the Program or Documentation, the government hereby agrees that this software or documentation qualifies as commercial computer software or commercial computer software documentation as such terms are used or defined in FAR 12.212, DFARS Part 227.72, and DFARS 252.227-7014. Accordingly, the terms and conditions of this Agreement and only those rights specified in this Agreement, shall pertain to and govern the use, modification, reproduction, release, performance, display, and disclosure of the Program and Documentation by the federal government (or other entity acquiring for or through the federal government) and shall supersede any conflicting contractual terms or conditions. If this License fails to meet the government's needs or is inconsistent in any respect with federal procurement law, the government agrees to return the Program and Documentation, unused, to The MathWorks, Inc.

Trademarks

MATLAB and Simulink are registered trademarks of The MathWorks, Inc. See www.mathworks.com/trademarks for a list of additional trademarks. Other product or brand names may be trademarks or registered trademarks of their respective holders.

Patents

MathWorks products are protected by one or more U.S. patents. Please see www.mathworks.com/patents for more information.

Revision History

December 1996	First printing	For MATLAB 5.0 (Release 8)
June 1997	Online only	Revised for MATLAB 5.1 (Release 9)
October 1997	Online only	Revised for MATLAB 5.2 (Release 10)
January 1999	Online only	Revised for MATLAB 5.3 (Release 11)
June 1999	Second printing	For MATLAB 5.3 (Release 11)
June 2001	Online only	Revised for MATLAB 6.1 (Release 12.1)
July 2002	Online only	Revised for 6.5 (Release 13)
June 2004	Online only	Revised for 7.0 (Release 14)
September 2006	Online only	Revised for 7.3 (Release 2006b)
March 2007	Online only	Revised for 7.4 (Release 2007a)
September 2007	Online only	Revised for Version 7.5 (Release 2007b)
March 2008	Online only	Revised for Version 7.6 (Release 2008a)
October 2008	Online only	Revised for Version 7.7 (Release 2008b)
March 2009	Online only	Revised for Version 7.8 (Release 2009a)
September 2009	Online only	Revised for Version 7.9 (Release 2009b)
March 2010	Online only	Revised for Version 7.10 (Release 2010a)
September 2010	Online only	Revised for Version 7.11 (Release 2010b)
April 2011	Online only	Revised for Version 7.12 (Release 2011a)
September 2011	Online only	Revised for Version 7.13 (Release 2011b)
March 2012	Online only	Revised for Version 7.14 (Release 2012a)
September 2012	Online only	Revised for Version 8.0 (Release 2012b)
March 2013	Online only	Revised for Version 8.1 (Release 2013a)
September 2013	Online only	Revised for Version 8.2 (Release 2013b)
March 2014	Online only	Revised for Version 8.3 (Release 2014a)

1 | Alphabetical List

2 | Functions — Alphabetical List

3 | Functions — Alphabetical List

Alphabetical List

Relational Operators < > <= >= == ~=
Logical Operators: Short-Circuit && ||
Special Characters [] () { } = ' , ; : % ! @
colon (:)
abs
accumarray
acos
acosd
acosh
acot
acotd
acoth
acsc
acscd
acsch
actxcontrol
actxcontrollist
actxcontrolselect
actxGetRunningServer
actxserver
matlab.apputil.create
matlab.apputil.getInstalledAppInfo
matlab.apputil.install
matlab.apputil.package
matlab.apputil.run
matlab.apputil.uninstall
addCause (MException)
addevent

audioinfo
audioread
audiowrite
addframe (avifile)
addlistener (handle)
addOptional
addParameter
addParamValue
addcats
addpath
addpref
addprop (dynamicprops)
addproperty
addRequired
addsampletocollection
addtodate
addts
airy
align
alim
all
allchild
alpha
alphamap
amd
ancestor
and, &
angle
annotation
Annotation Arrow Properties
Annotation Doublearrow Properties
Annotation Ellipse Properties
Annotation Line Properties
Annotation Rectangle Properties
Annotation Textarrow Properties
Annotation Textbox Properties
ans

any
area
Areaseries Properties
array2table
arrayfun
ascii
asec
asecd
asech
asin
asind
asinh
assert
assignin
atan
atan2
atan2d
atand
atanh
audiodevinfo
audioplayer
audiorecorder
aufinfo
auread
auwrite
avifile
aviinfo
aviread
axes
Axes Properties
axis
balance
bandwidth
bar
barh
bar3
bar3h

Barseries Properties

baryToCart

base2dec

beep

BeginInvoke

bench

besselh

besseli

besselj

besselk

bessely

beta

betainc

betaincinv

betaln

bicg

bicgstab

bicgstabl

bin2dec

binary

bitand

bitcmp

bitget

bitmax

bitnot

bitor

bitset

bitshift

bitxor

blanks

blkdiag

box

break

brighten

brush

bsxfun

bulddocsearchdb

builtin
bvp4c
bvp5c
bvpget
bvpinit
bvpset
bvpxtend
calendar
calllib
callSoapService
camdolly
cameratoolbar
camlight
camlookat
camorbit
campan
campos
camproj
camroll
camtargat
camup
camva
camzoom
cartToBary
cart2pol
cart2sph
cast
cat
categorical
categories
caxis
cd
convexHull
cd
cdf2rdf
cdfepoch
cdfinfo

cdflib
cdflib.close
cdflib.closeVar
cdflib.computeEpoch
cdflib.computeEpoch16
cdflib.create
cdflib.createAttr
cdflib.createVar
cdflib.delete
cdflib.deleteAttr
cdflib.deleteAttrEntry
cdflib.deleteAttrgEntry
cdflib.deleteVar
cdflib.deleteVarRecords
cdflib.epoch16Breakdown
cdflib.epochBreakdown
cdflib.getAttrEntry
cdflib.getAttrgEntry
cdflib.getAttrMaxEntry
cdflib.getAttrMaxgEntry
cdflib.getAttrName
cdflib.getAttrNum
cdflib.getAttrScope
cdflib.getCacheSize
cdflib.getChecksum
cdflib.getCompression
cdflib.getCompressionCacheSize
cdflib.getConstantNames
cdflib.getConstantValue
cdflib.getCopyright
cdflib.getFileBackward
cdflib.getFormat
cdflib.getLibraryCopyright
cdflib.getLibraryVersion
cdflib.getMajority
cdflib.getName
cdflib.getNumAttrEntries

cdflib.getNumAttrgEntries
cdflib.getNumAttributes
cdflib.getNumgAttributes
cdflib.getReadOnlyMode
cdflib.getStageCacheSize
cdflib.getValidate
cdflib.getVarAllocRecords
cdflib.getVarBlockingFactor
cdflib.getVarCacheSize
cdflib.getVarCompression
cdflib.getVarData
cdflib.getVarMaxAllocRecNum
cdflib.getVarMaxWrittenRecNum
cdflib.getVarsMaxWrittenRecNum
cdflib.getVarName
cdflib.getVarNum
cdflib.getVarNumRecsWritten
cdflib.getVarPadValue
cdflib.getVarRecordData
cdflib.getVarReservePercent
cdflib.getVarSparseRecords
cdflib.getVersion
cdflib.hyperGetVarData
cdflib.hyperPutVarData
cdflib.inquire
cdflib.inquireAttr
cdflib.inquireAttrEntry
cdflib.inquireAttrgEntry
cdflib.inquireVar
cdflib.open
cdflib.putAttrEntry
cdflib.putAttrgEntry
cdflib.putVarData
cdflib.putVarRecordData
cdflib.renameAttr
cdflib.renameVar
cdflib.setCacheSize

cdflib.setChecksum
cdflib.setCompression
cdflib.setCompressionCacheSize
cdflib.setFileBackward
cdflib.setFormat
cdflib.setMajority
cdflib.setReadOnlyMode
cdflib.setStageCacheSize
cdflib.setValidate
cdflib.setVarAllocBlockRecords
cdflib.setVarBlockingFactor
cdflib.setVarCacheSize
cdflib.setVarCompression
cdflib.setVarInitialRecs
cdflib.setVarPadValue
cdflib.SetVarReservePercent
cdflib.setVarsCacheSize
cdflib.setVarSparseRecords
cdfread
cdfwrite
ceil
cell
cell2mat
cell2struct
cell2table
celldisp
cellfun
cellplot
cellstr
cgs
char
checkcode
checkin
checkout
chol
cholupdate
circshift

circumcenters
cla
clabel
class
classdef
clc
clear
clearvars
clear (serial)
clf
clipboard
clock
close
close
close (avifile)
close
close
closereq
cmopts
cmpermute
cmunique
colamd
colorbar
colordef
colormap
colormapeditor
ColorSpec (Color Specification)
colperm
Combine
comet
comet3
commandhistory
commandwindow
compan
compass
complex
computeStrip

computeTile
computer
cond
condeig
condest
coneplot
conj
continue
contour
contour3
contourc
contourf
Contourgroup Properties
contourslice
matlab.unittest.constraints
matlab.unittest.constraints.AbsoluteTolerance
and
or
matlab.unittest.constraints.AnyCellOf
matlab.unittest.constraints.AnyElementOf
matlab.unittest.constraints.BooleanConstraint
and
getNegativeDiagnosticFor
not
or
matlab.unittest.constraints.CellComparator
matlab.unittest.constraints.Constraint
getDiagnosticFor
satisfiedBy
matlab.unittest.constraints.ContainsSubstring
matlab.unittest.constraints.EndsWithSubstring
matlab.unittest.constraints.Eventually
matlab.unittest.constraints.EveryCellOf
matlab.unittest.constraints.EveryElementOf
matlab.unittest.constraints.HasElementCount
matlab.unittest.constraints.HasField
matlab.unittest.constraints.HasInf

matlab.unittest.constraints.HasLength
matlab.unittest.constraints.HasNaN
matlab.unittest.constraints.HasSize
matlab.unittest.constraints.IsAnything
matlab.unittest.constraints.IsEmpty
matlab.unittest.constraints.IsFalse
matlab.unittest.constraints.IsFinite
matlab.unittest.constraints.IsGreaterThan
matlab.unittest.constraints.IsGreaterThanOrEqualTo
matlab.unittest.constraints.IsEqualTo
matlab.unittest.constraints.IsInstanceOf
matlab.unittest.constraints.IsLessThan
matlab.unittest.constraints.IsLessThanOrEqualTo
matlab.unittest.constraints.IsOfClass
matlab.unittest.constraints.IsReal
matlab.unittest.constraints.IsSameHandleAs
matlab.unittest.constraints.IsSparse
matlab.unittest.constraints.IsSubstringOf
matlab.unittest.constraints.IssuesNoWarnings
matlab.unittest.constraints.IssuesWarnings
matlab.unittest.constraints.IsTrue
matlab.unittest.constraints.LogicalComparator
matlab.unittest.constraints.Matches
matlab.unittest.constraints.NumericComparator
matlab.unittest.constraints.ObjectComparator
matlab.unittest.constraints.PublicPropertyComparator
matlab.unittest.constraints.RelativeTolerance
and
or
matlab.unittest.constraints>ReturnsTrue
matlab.unittest.constraints.StartsWithSubstring
matlab.unittest.constraints.StringComparator
matlab.unittest.constraints.StructComparator
matlab.unittest.constraints.Throws
matlab.unittest.constraints.Tolerance
getDiagnosticFor
satisfiedBy

supports
contrast
conv
conv2
convhull
convhulln
convn
matlab.mixin.CustomDisplay
convertDimensionsToString
details
disp
display
displayEmptyObject
displayNonScalarObject
displayPropertyGroups
displayScalarHandleToDeletedObject
displayScalarObject
getClassNameForHeader
getDeletedHandleText
getDetailedFooter
getDetailedHeader
getFooter
getHandleText
getHeader
getPropertyGroups
getSimpleHeader
matlab.mixin.Copyable
copy
copyfile
copyobj
corrcoef
cos
cosd
cosh
cot
cotd
coth

countcats
cov
cplxpair
cputime
RandStream.create
createClassFromWsd
createCopy
createSoapMessage
cross
csc
cscd
csch
csvread
ctranspose
csvwrite
cumprod
cumsum
cumtrapz
curl
currentDirectory
customverctrl
cylinder
daqread
daspect
datacursormode
datatipinfo
date
datenum
datestr
datetick
datevec
dbclear
dbcont
dbdown
dblquad
dbmex
dbquit

dbstack
dbstatus
dbstep
dbstop
dbtype
dbup
dde23
ddeget
ddensd
ddesd
ddeset
deal
deblank
dec2base
dec2bin
dec2hex
decic
deconv
del2
DelaunayTri
DelaunayTri
delaunay
delaunayn
delaunayTriangulation
convexHull
isInterior
nearestNeighbor
pointLocation
voronoiDiagram
delete
delete (COM)
delete
delete (handle)
delete (serial)
deleteproperty
delevent
delsamplefromcollection

demo
demdir
depfun
det
details
detrend
deval
diag
matlab.unittest.diagnostics
matlab.unittest.diagnostics.ConstraintDiagnostic
addCondition
addConditionsFrom
getDisplayableString
getPreDescriptionString
getPostDescriptionString
getPostConditionString
getPostActValString
getPostExpValString
matlab.unittest.diagnostics.Diagnostic
diagnose
join
matlab.unittest.diagnostics.DisplayDiagnostic
matlab.unittest.diagnostics.FunctionHandleDiagnostic
matlab.unittest.diagnostics.StringDiagnostic
dialog
diary
diff
diffuse
dir
dir
disp
disp (MException)
disp (serial)
display
dither
divergence
dlmread

dlmwrite
dmperm
doc
docsearch
dos
dot
double
dragrect
drawnow
dsearchn
dynamicprops
echo
echodemo
edgeAttachments
edges
edit
eig
eigs
ellipj
ellipke
ellipsoid
empty
enableNETfromNetworkDrive
enableservice
end
EndInvoke
eomday
enumeration
eps
eq, ==
eq (MException)
erf
erfc
erfcinv
erfcx
erfinv
error

errorbar
Errorbarseries Properties
errordlg
etime
etree
etreeplot
eval
evalc
evalin
event.EventData
event.listener
event.PropertyEvent
event.proplistener
eventlisteners
events
events (COM)
Execute
exifread
exist
exit
exp
expint
expm
expm1
export2wsdlg
eye
ezcontour
ezcontourf
ezmesh
ezmeshc
ezplot
ezplot3
ezpolar
ezsurf
ezsurf
faceNormals
factor

factorial
false
fclose
fclose (serial)
feather
featureEdges
feof
ferror
feval
Feval (COM)
fft
fft2
fftn
fftshift
fftw
fgetl
fgetl (serial)
fgets
fgets (serial)
fieldnames
figure
Figure Properties
figurepalette
fileattrib
filebrowser
filemarker
fileparts
fileread
filesep
fill
fill3
filter
filter2
find
findall
findfigs
findobj

findobj (handle)
findprop (handle)
findstr
finish
fitsdisp
fitsinfo
fitsread
fitswrite
fix
matlab.unittest.fixtures
matlab.unittest.fixtures.CurrentFolderFixture
matlab.unittest.fixtures.Fixture
setup
teardown
addTeardown
isCompatible
matlab.unittest.fixtures.PathFixture
matlab.unittest.fixtures.SuppressedWarningsFixture
matlab.unittest.fixtures.TemporaryFolderFixture
flintmax
flip
flipdim
fliplr
flipud
floor
flow
fminbnd
fminsearch
fopen
fopen (serial)
for
format
fplot
fprintf
fprintf (serial)
frame2im
fread

fread (serial)
freeBoundary
freqspace
frewind
fscanf
fscanf (serial)
fseek
ftell
FTP
full
fullfile
func2str
function
function_handle (@)
functions
functiontests
funm
fwrite
fwrite (serial)
fzero
gallery
gamma
gammaln
gammaln
gammaln
gca
gcbf
gcbo
gcd
gcf
gco
ge, >=
genpath
genvarname
get
get
get

get (COM)
get (hgsetget)
get
get (RandStream)
get (serial)
get (tscollection)
getabstime (tscollection)
getappdata
getaudiodata
GetCharArray
getdisp (hgsetget)
getenv
getfield
getFileFormats
getframe
GetFullMatrix
getpixelposition
getpref
getProfiles
getReport (MException)
getsamplingtime (tscollection)
getTag
getTagNames
gettimeseriesnames
gettsafteratevent
gettsafterevent
gettsatevent
gettsbeforeatevent
gettsbeforeevent
gettsbetweenevents
GetVariable
getVersion
GetWorkspaceData
ginput
global
gmres
gobjects

gplot
grabcode
gradient
graymon
grid
griddata
griddatan
griddedInterpolant
gsvd
gt, >
gtext
guidata
guide
guihandles
gunzip
gzip
h5create
h5disp
h5info
h5read
h5readatt
h5write
h5writeatt
H5.close
H5.garbage_collect
H5.get_libversion
H5.open
H5.set_free_list_limits
H5A.close
H5A.create
H5A.delete
H5A.get_info
H5A.get_name
H5A.get_space
H5A.get_type
H5A.iterate
H5A.open

H5A.open_by_idx
H5A.open_by_name
H5A.read
H5A.write
H5D.close
H5D.create
H5D.get_access_plist
H5D.get_create_plist
H5D.get_offset
H5D.get_space
H5D.get_space_status
H5D.get_storage_size
H5D.get_type
H5D.open
H5D.read
H5D.set_extent
H5D.vlen_get_buf_size
H5D.write
H5DS.attach_scale
H5DS.detach_scale
H5DS.get_label
H5DS.get_num_scales
H5DS.get_scale_name
H5DS.is_scale
H5DS.iterate_scales
H5DS.set_label
H5DS.set_scale
H5E.clear
H5E.get_major
H5E.get_minor
H5E.walk
H5F.close
H5F.create
H5F.flush
H5F.get_access_plist
H5F.get_create_plist
H5F.get_filesize

H5F.get_freespace
H5F.get_info
H5F.get_mdc_config
H5F.get_mdc_hit_rate
H5F.get_mdc_size
H5F.get_name
H5F.get_obj_count
H5F.get_obj_ids
H5F.is_hdf5
H5F.mount
H5F.open
H5F.reopen
H5F.set_mdc_config
H5F.unmount
H5G.close
H5G.create
H5G.get_info
H5G.open
H5I.dec_ref
H5I.get_file_id
H5I.get_name
H5I.get_ref
H5I.get_type
H5I.inc_ref
H5I.is_valid
H5L.copy
H5L.create_external
H5L.create_hard
H5L.create_soft
H5L.delete
H5L.exists
H5L.get_info
H5L.get_name_by_idx
H5L.get_val
H5L.iterate
H5L.iterate_by_name
H5L.move

H5L.visit
H5L.visit_by_name
H5ML.compare_values
H5ML.get_constant_names
H5ML.get_constant_value
H5ML.get_function_names
H5ML.get_mem_datatype
H5ML.hoffset
H5ML.sizeof
H5O.close
H5O.copy
H5O.get_comment
H5O.get_comment_by_name
H5O.get_info
H5O.link
H5O.open
H5O.open_by_idx
H5O.set_comment
H5O.set_comment_by_name
H5O.visit
H5O.visit_by_name
H5P.close
H5P.copy
H5P.create
H5P.get_class
H5P.close_class
H5P.equal
H5P.exist
H5P.get
H5P.get_class_name
H5P.get_class_parent
H5P.get_nprops
H5P.get_size
H5P.isa_class
H5P.iterate
H5P.set
H5P.get_btree_ratios

H5P.get_chunk_cache
H5P.get_dxpl_multi
H5P.get_edc_check
H5P.get_hyper_vector_size
H5P.set_btree_ratios
H5P.set_chunk_cache
H5P.set_dxpl_multi
H5P.set_edc_check
H5P.set_hyper_vector_size
H5P.all_filters_avail
H5P.fill_value_defined
H5P.get_alloc_time
H5P.get_chunk
H5P.get_external
H5P.get_external_count
H5P.get_fill_time
H5P.get_fill_value
H5P.get_filter
H5P.get_filter_by_id
H5P.get_layout
H5P.get_nfilters
H5P.modify_filter
H5P.remove_filter
H5P.set_alloc_time
H5P.set_chunk
H5P.set_deflate
H5P.set_external
H5P.set_fill_time
H5P.set_fill_value
H5P.set_filter
H5P.set_fletcher32
H5P.set_layout
H5P.set_nbit
H5P.set_scaleoffset
H5P.set_shuffle
H5P.get_alignment
H5P.get_driver

H5P.get_family_offset
H5P.get_fapl_core
H5P.get_fapl_family
H5P.get_fapl_multi
H5P.get_fclose_degree
H5P.get_libver_bounds
H5P.get_gc_references
H5P.get_mdc_config
H5P.get_meta_block_size
H5P.get_multi_type
H5P.get_sieve_buf_size
H5P.get_small_data_block_size
H5P.set_alignment
H5P.set_family_offset
H5P.set_fapl_core
H5P.set_fapl_family
H5P.set_fapl_log
H5P.set_fapl_multi
H5P.set_fapl_sec2
H5P.set_fapl_split
H5P.set_fapl_stdio
H5P.set_fclose_degree
H5P.set_gc_references
H5P.set_libver_bounds
H5P.set_mdc_config
H5P.set_meta_block_size
H5P.set_multi_type
H5P.set_sieve_buf_size
H5P.set_small_data_block_size
H5P.get_istore_k
H5P.get_sizes
H5P.get_sym_k
H5P.get_userblock
H5P.get_version
H5P.set_istore_k
H5P.set_sizes
H5P.set_sym_k

H5P.set_userblock
H5P.get_attr_creation_order
H5P.get_attr_phase_change
H5P.get_copy_object
H5P.set_attr_creation_order
H5P.set_attr_phase_change
H5P.set_copy_object
H5P.get_create_intermediate_group
H5P.get_link_creation_order
H5P.get_link_phase_change
H5P.set_create_intermediate_group
H5P.set_link_creation_order
H5P.set_link_phase_change
H5P.get_char_encoding
H5P.set_char_encoding
H5R.create
H5R.dereference
H5R.get_name
H5R.get_obj_type
H5R.get_region
H5S.copy
H5S.create
H5S.close
H5S.create_simple
H5S.extent_copy
H5S.get_select_bounds
H5S.get_select_elem_npoints
H5S.get_select_elem_pointlist
H5S.get_select_hyper_blocklist
H5S.get_select_hyper_nblocks
H5S.get_select_npoints
H5S.get_select_type
H5S.get_simple_extent_dims
H5S.get_simple_extent_ndims
H5S.get_simple_extent_npoints
H5S.get_simple_extent_type
H5S.is_simple

H5S.offset_simple
H5S.select_all
H5S.select_elements
H5S.select_hyperslab
H5S.select_none
H5S.select_valid
H5S.set_extent_none
H5S.set_extent_simple
H5T.close
H5T.commit
H5T.committed
H5T.copy
H5T.create
H5T.detect_class
H5T.equal
H5T.get_class
H5T.get_create_plist
H5T.get_native_type
H5T.get_size
H5T.get_super
H5T.lock
H5T.open
H5T.array_create
H5T.get_array_dims
H5T.get_array_ndims
H5T.get_cset
H5T.get_ebias
H5T.get_fields
H5T.get_inpad
H5T.get_norm
H5T.get_offset
H5T.get_order
H5T.get_pad
H5T.get_precision
H5T.get_sign
H5T.get_strpad
H5T.set_cset

H5T.set_ebias
H5T.set_fields
H5T.set_inpad
H5T.set_norm
H5T.set_offset
H5T.set_order
H5T.set_pad
H5T.set_precision
H5T.set_sign
H5T.set_size
H5T.set_strpad
H5T.get_member_class
H5T.get_member_index
H5T.get_member_name
H5T.get_member_offset
H5T.get_member_type
H5T.get_nmembers
H5T.insert
H5T.pack
H5T.enum_create
H5T.enum_insert
H5T.enum_nameof
H5T.enum_valueof
H5T.get_member_value
H5T.get_tag
H5T.set_tag
H5T.is_variable_str
H5T.vlen_create
H5Z.filter_avail
H5Z.get_filter_info
hadamard
handle
hankel
hdf5info
hdf5read
hdf5write
hdfan

hdfdf24
hdfdf8
hdfh
hdfhd
hdfhe
hdfhx
hdfinfo
hdfml
hdfpt
hdfread
hdftool
hdfv
hdfvf
hdfvh
hdfvs
height
help
helpbrowser
helpdesk
helpdlg
helpwin
hess
matlab.mixin.Heterogeneous
cat
getDefaultScalarElement
horzcat
vertcat
hex2dec
hex2num
hgexport
hggroup
Hggroup Properties
hgload
hgsave
hgsetget
hgtransform
Hgtransform Properties

hidden
hilb
hist
histc
hold
home
horzcat
horzcat (tscollection)
hsv2rgb
hypot
i
ichol
idivide
if, elseif, else
ifft
ifft2
ifftn
ifftshift
ilu
im2frame
im2java
imag
image
Image Properties
imagesc
imapprox
imfinfo
imformats
import
importdata
imread
imwrite
incenters
inOutStatus
ind2rgb
ind2sub
Inf

inferiorto
info
inline
inmem
innerjoin
inpolygon
input
inputdlg
inputname
inputParser
inspect
instrcallback
instrfind
instrfindall
int2str
int8
int16
int32
int64
integral
integral2
integral3
interfaces
interp1
interp1q
interp2
interp3
interpft
interp
interpstreamspeed
intersect
intmax
intmin
inv
invhilb
invoke
ipermute

is*
isa
isappdata
isbanded
iscategorical
iscategory
iscell
iscellstr
ischar
iscolumn
iscom
isdiag
isdir
isEdge
isempty
isempty (tscollection)
isequal
isequaln
isequal (MException)
isequalwithequalnans
isevent
isfield
isfinite
isfloat
isglobal
ishandle
ishermitian
ishghandle
ishold
isinf
isinteger
isinterface
isjava
isKey
iskeyword
isletter
islogical

ismac
ismatrix
ismember
ismethod
ismethod (COM)
ismissing
isnan
isnumeric
isobject
isocaps
isocolors
isonormals
isordinal
isosurface
ispc
ispref
isprime
isprop
isprop (COM)
isprotected
isreal
isrow
isscalar
issorted
isspace
issparse
isstr
isstrprop
isstruct
isstudent
issymmetric
isTiled
istable
istril
istriu
isundefined
isunix

isvalid (handle)
isvalid (serial)
isvarname
isvector
j
javaaddpath
javaArray
javachk
javaclasspath
matlab.exception.JavaException
javaMethod
javaMethodEDT
javaObject
javaObjectEDT
javarmpath
join
keyboard
keys
kron
last (MException)
lastDirectory
lasterr
lasterror
lastwarn
lcm
ldl
ldivide, .\
le, <=
legend
legendre
length
length
length (serial)
length (tscollection)
libfunctions
libfunctionsview
libisloaded

libpointer
lib.pointer
disp
isNull
plus
reshape
setdatatype
libstruct
license
light
Light Properties
lightangle
lighting
lin2mu
line
Line Properties
Lineseries Properties
LineSpec (Line Specification)
linkaxes
linkdata
linkprop
linsolve
linspace
RandStream.list
listdlg
listfonts
load
load (COM)
load (serial)
loadlibrary
loadobj
localfunctions
log
log10
log1p
log2
logical

loglog
logm
logspace
lookfor
lower
ls
lscov
lsqnonneg
lsqr
lt, <
lu
magic
makehgtform
containers.Map
mat2cell
mat2str
material
matfile
matlab.codetools.requiredFilesAndProducts
matlab.io.MatFile
matlab.io.fits.closeFile
matlab.io.fits.createFile
matlab.io.fits.deleteFile
matlab.io.fits.fileName
matlab.io.fits.fileMode
matlab.io.fits.openFile
matlab.io.fits.createImg
matlab.io.fits.getImgSize
matlab.io.fits.getImgType
matlab.io.fits.insertImg
matlab.io.fits.readImg
matlab.io.fits.setBscale
matlab.io.fits.writeImg
matlab.io.fits.deleteKey
matlab.io.fits.deleteRecord
matlab.io.fits.getHdrSpace
matlab.io.fits.readCard

matlab.io.fits.readKey
matlab.io.fits.readKeyCmplx
matlab.io.fits.readKeyDbl
matlab.io.fits.readKeyLongLong
matlab.io.fits.readKeyLongStr
matlab.io.fits.readKeyUnit
matlab.io.fits.readRecord
matlab.io.fits.writeComment
matlab.io.fits.writeDate
matlab.io.fits.writeKey
matlab.io.fits.writeKeyUnit
matlab.io.fits.writeHistory
matlab.io.fits.copyHDU
matlab.io.fits.deleteHDU
matlab.io.fits.getHDUnum
matlab.io.fits.getHDUtype
matlab.io.fits.getNumHDUs
matlab.io.fits.movAbsHDU
matlab.io.fits.movNamHDU
matlab.io.fits.movRelHDU
matlab.io.fits.writeChecksum
matlab.io.fits.imgCompress
matlab.io.fits.isCompressedImg
matlab.io.fits.setCompressionType
matlab.io.fits.setHCompScale
matlab.io.fits.setHCompSmooth
matlab.io.fits.setTileDim
matlab.io.fits.createTbl
matlab.io.fits.deleteCol
matlab.io.fits.deleteRows
matlab.io.fits.insertRows
matlab.io.fits.getAColParms
matlab.io.fits.getBColParms
matlab.io.fits.getColName
matlab.io.fits.getColType
matlab.io.fits.getEqColType
matlab.io.fits.getNumCols

matlab.io.fits.getNumRows
matlab.io.fits.insertCol
matlab.io.fits.insertATbl
matlab.io.fits.insertBTbl
matlab.io.fits.readATblHdr
matlab.io.fits.readBTblHdr
matlab.io.fits.readCol
matlab.io.fits.setTscale
matlab.io.fits.writeCol
matlab.io.fits.getConstantValue
matlab.io.fits.getVersion
matlab.io.fits.getOpenFiles
matlab.io.hdf4.sd
matlab.io.hdf4.sd.attrInfo
matlab.io.hdf4.sd.close
matlab.io.hdf4.sd.create
matlab.io.hdf4.sd.dimInfo
matlab.io.hdf4.sd.endAccess
matlab.io.hdf4.sd.fileInfo
matlab.io.hdf4.sd.findAttr
matlab.io.hdf4.sd.getCal
matlab.io.hdf4.sd.getChunkInfo
matlab.io.hdf4.sd.getCompInfo
matlab.io.hdf4.sd.getDataStrs
matlab.io.hdf4.sd.getDimID
matlab.io.hdf4.sd.getDimScale
matlab.io.hdf4.sd.getDimStrs
matlab.io.hdf4.sd.getFilename
matlab.io.hdf4.sd.getFillValue
matlab.io.hdf4.sd.getInfo
matlab.io.hdf4.sd.getRange
matlab.io.hdf4.sd.idToRef
matlab.io.hdf4.sd.idType
matlab.io.hdf4.sd.isCoordVar
matlab.io.hdf4.sd.isRecord
matlab.io.hdf4.sd.nameToIndex
matlab.io.hdf4.sd.nameToIndices

matlab.io.hdf4.sd.readAttr
matlab.io.hdf4.sd.readChunk
matlab.io.hdf4.sd.readData
matlab.io.hdf4.sd.refToIndex
matlab.io.hdf4.sd.select
matlab.io.hdf4.sd.setAttr
matlab.io.hdf4.sd.setCal
matlab.io.hdf4.sd.setChunk
matlab.io.hdf4.sd.setCompress
matlab.io.hdf4.sd.setDataStrs
matlab.io.hdf4.sd.setDimName
matlab.io.hdf4.sd.setDimScale
matlab.io.hdf4.sd.setDimStrs
matlab.io.hdf4.sd.setExternalFile
matlab.io.hdf4.sd.setFillMode
matlab.io.hdf4.sd.setFillValue
matlab.io.hdf4.sd.setNBitDataSet
matlab.io.hdf4.sd.setRange
matlab.io.hdf4.sd.start
matlab.io.hdf4.sd.writeChunk
matlab.io.hdf4.sd.writeData
matlab.io.hdfeos.gd
matlab.io.hdfeos.gd.attach
matlab.io.hdfeos.gd.close
matlab.io.hdfeos.gd.compInfo
matlab.io.hdfeos.gd.create
matlab.io.hdfeos.gd.defBoxRegion
matlab.io.hdfeos.gd.defComp
matlab.io.hdfeos.gd.defDim
matlab.io.hdfeos.gd.defField
matlab.io.hdfeos.gd.defOrigin
matlab.io.hdfeos.gd.defPixReg
matlab.io.hdfeos.gd.defProj
matlab.io.hdfeos.gd.defTile
matlab.io.hdfeos.gd.defVrtRegion
matlab.io.hdfeos.gd.detach
matlab.io.hdfeos.gd.dimInfo

matlab.io.hdfeos.gd.extractRegion
matlab.io.hdfeos.gd.fieldInfo
matlab.io.hdfeos.gd.getFillValue
matlab.io.hdfeos.gd.getPixels
matlab.io.hdfeos.gd.getPixValues
matlab.io.hdfeos.gd.gridInfo
matlab.io.hdfeos.gd.ij2ll
matlab.io.hdfeos.gd.inqAttrs
matlab.io.hdfeos.gd.inqDims
matlab.io.hdfeos.gd.inqFields
matlab.io.hdfeos.gd.inqGrid
matlab.io.hdfeos.gd.ll2ij
matlab.io.hdfeos.gd.nEntries
matlab.io.hdfeos.gd.open
matlab.io.hdfeos.gd.originInfo
matlab.io.hdfeos.gd.pixRegInfo
matlab.io.hdfeos.gd.projInfo
matlab.io.hdfeos.gd.readAttr
matlab.io.hdfeos.gd.readBlkSomOffset
matlab.io.hdfeos.gd.readField
matlab.io.hdfeos.gd.readTile
matlab.io.hdfeos.gd.regionInfo
matlab.io.hdfeos.gd.setFillValue
matlab.io.hdfeos.gd.setTileComp
matlab.io.hdfeos.gd.sphereCodeToName
matlab.io.hdfeos.gd.sphereNameToCode
matlab.io.hdfeos.gd.tileInfo
matlab.io.hdfeos.gd.writeAttr
matlab.io.hdfeos.gd.writeBlkSomOffset
matlab.io.hdfeos.gd.writeField
matlab.io.hdfeos.gd.writeTile
matlab.io.hdfeos.sw
matlab.io.hdfeos.sw.attach
matlab.io.hdfeos.sw.close
matlab.io.hdfeos.sw.compInfo
matlab.io.hdfeos.sw.create
matlab.io.hdfeos.sw.defBoxRegion

matlab.io.hdfEOS.sw.defComp
matlab.io.hdfEOS.sw.defDataField
matlab.io.hdfEOS.sw.defDim
matlab.io.hdfEOS.sw.defDimMap
matlab.io.hdfEOS.sw.defGeoField
matlab.io.hdfEOS.sw.defTimePeriod
matlab.io.hdfEOS.sw.defVrtRegion
matlab.io.hdfEOS.sw.detach
matlab.io.hdfEOS.sw.dimInfo
matlab.io.hdfEOS.sw.extractPeriod
matlab.io.hdfEOS.sw.extractRegion
matlab.io.hdfEOS.sw.fieldInfo
matlab.io.hdfEOS.sw.geoMapInfo
matlab.io.hdfEOS.sw.getFillValue
matlab.io.hdfEOS.sw.idxMapInfo
matlab.io.hdfEOS.sw.inqAttrs
matlab.io.hdfEOS.sw.inqDataFields
matlab.io.hdfEOS.sw.inqDims
matlab.io.hdfEOS.sw.inqGeoFields
matlab.io.hdfEOS.sw.inqIdxMaps
matlab.io.hdfEOS.sw.inqMaps
matlab.io.hdfEOS.sw.inqSwath
matlab.io.hdfEOS.sw.mapInfo
matlab.io.hdfEOS.sw.nEntries
matlab.io.hdfEOS.sw.open
matlab.io.hdfEOS.sw.periodInfo
matlab.io.hdfEOS.sw.readAttr
matlab.io.hdfEOS.sw.readField
matlab.io.hdfEOS.sw.regionInfo
matlab.io.hdfEOS.sw.setFillValue
matlab.io.hdfEOS.sw.writeAttr
matlab.io.hdfEOS.sw.writeField
matlab.io.saveVariablesToScript
matlab.lang.makeUniqueStrings
matlab.lang.makeValidName
matlabrc
matlabroot

matlab (UNIX)
matlab (Windows)
max
MaximizeCommandWindow
maxNumCompThreads
mean
median
mmapfile
memory
menu
mergocats
mesh
meshc
meshz
meshgrid
meta.class
meta.class.fromName
meta.DynamicProperty
meta.EnumeratedValue
meta.event
meta.MetaData
meta.method
meta.package
meta.abstractDetails
meta.package.fromName
meta.package.getAllPackages
meta.property
metaclass
methods
methodsview
mex
mex.getCompilerConfigurations
MException
mexext
mfilename
mget
min

MinimizeCommandWindow

minres

minus, -

mislocked

mkdir

mkdir

mkpp

mldivide, \

mrdivide, /

mlint

mlintrpt

mlock

mmfileinfo

mmreader

mod

mode

more

move

movefile

movegui

movie

movie2avi

mpower, ^

mput

msgbox

mtimes, *

mu2lin

multibandread

multibandwrite

munlock

namelengthmax

NaN

nargchk

nargin

narginchk

nargout

nargoutchk

native2unicode
nchoosek
ndgrid
ndims
ne, ~=
nearestNeighbor
ne (MException)
neighbors
NET
NET.addAssembly
NET.Assembly
NET.convertArray
NET.createArray
NET.createGeneric
NET.disableAutoRelease
NET.enableAutoRelease
NET.GenericClass
NET.invokeGenericMethod
NET.isNETSupported
NET.NetException
NET.setStaticProperty
ncreate
ncdisp
ncinfo
ncread
ncreadatt
ncwrite
ncwriteatt
ncwriteschema
netcdf
netcdf.abort
netcdf.close
netcdf.copyAtt
netcdf.create
netcdf.defDim
netcdf.defGrp
netcdf.defVar

netcdf.defVarChunking
netcdf.defVarDeflate
netcdf.defVarFill
netcdf.defVarFletcher32
netcdf.delAtt
netcdf.endDef
netcdf.getAtt
netcdf.getChunkCache
netcdf.getConstant
netcdf.getConstantNames
netcdf.getVar
netcdf.inq
netcdf.inqDimIDs
netcdf.inqFormat
netcdf.inqGrpName
netcdf.inqGrpNameFull
netcdf.inqGrpParent
netcdf.inqGrps
netcdf.inqNcid
netcdf.inqUnlimDims
netcdf.inqVarIDs
netcdf.inqVarChunking
netcdf.inqVarDeflate
netcdf.inqVarFill
netcdf.inqVarFletcher32
netcdf.inqAtt
netcdf.inqAttID
netcdf.inqAttName
netcdf.inqDim
netcdf.inqDimID
netcdf.inqLibVers
netcdf.inqVar
netcdf.inqVarID
netcdf.open
netcdf.putAtt
netcdf.putVar
netcdf.reDef

netcdf.renameAtt
netcdf.renameDim
netcdf.renameVar
netcdf.setChunkCache
netcdf.setDefaultFormat
netcdf.setFill
netcdf.sync
newplot
nextDirectory
nextpow2
nnz
noanimate
nonzeros
norm
normest
not, ~
notebook
notify (handle)
now
nthroot
null
num2cell
num2hex
num2str
numberOfStrips
numberOfTiles
numel
nzmax
ode15i
ode15s
ode23
ode23s
ode23t
ode23tb
ode45
ode113
odeget

odeset
odextend
onCleanup
ones
open
open
openfig
opengl
openvar
optimget
optimset
or, |
ordeig
orderfields
ordqz
ordschur
orient
orth
outerjoin
pack
padecoef
pagesetupdlg
pan
matlab.unittest.parameters
matlab.unittest.parameters.EmptyParameter
matlab.unittest.parameters.ClassSetupParameter
matlab.unittest.parameters.TestParameter
matlab.unittest.parameters.MethodSetupParameter
pareto
parfor
parse
parseSoapResponse
pascal
patch
Patch Properties
path
path2rc

pathsep
pathtool
pause
pbaspect
pcg
pchip
pcode
pcolor
pdepe
pdeval
peaks
perl
perms
permute
persistent
pi
pie
pie3
pinv
planerot
play
play
playblocking
plot
plot3
plotbrowser
plotedit
plotmatrix
plottools
plotyy
matlab.unittest.plugins
matlab.unittest.plugins.DiagnosticsValidationPlugin
matlab.unittest.plugins.FailureDiagnosticsPlugin
matlab.unittest.plugins.OutputStream
print
matlab.unittest.plugins.StopOnFailuresPlugin
matlab.unittest.plugins.TAPPlugin

matlab.unittest.plugins.ToFile
matlab.unittest.plugins.ToStandardOutput
matlab.unittest.plugins.TestRunnerPlugin
runTestSuite
createSharedTestFixture
setupSharedTestFixture
runTestClass
createTestClassInstance
setupTestClass
runTest
createTestMethodInstance
setupTestMethod
runTestMethod
teardownTestMethod
teardownTestClass
teardownSharedTestFixture
matlab.unittest.plugins.TestSuiteProgressPlugin
matlab.unittest.plugins.plugindata
matlab.unittest.plugins.plugindata.PluginData
matlab.unittest.plugins.plugindata.SharedTestFixturePluginData
matlab.unittest.plugins.plugindata.TestSuiteRunPluginData
plus, +
pointLocation
pol2cart
polar
poly
polyarea
polyder
polyeig
polyfit
polyint
polyval
polyvalm
pow2
power, .^
ppval
prefdir

preferences
primes
print
printopt
printdlg
printpreview
prod
profile
profsave
propedit
propedit (COM)
properties
propertyeditor
matlab.mixin.util.PropertyGroup
psi
publish
PutCharArray
PutFullMatrix
PutWorkspaceData
pwd
qmr
qr
qrdelete
qrinsert
qrupdate
quad
quad2d
quadgk
quadl
quadv
matlab.unittest.qualifications
matlab.unittest.qualifications.Assertable
assertClass
assertEmpty
assertEqual
assertError
assertFail

assertFalse
assertGreaterThan
assertGreaterThanOrEqual
assertInstanceOf
assertLength
assertLessThan
assertLessThanOrEqual
assertMatches
assertNotEmpty
assertNotEqual
assertNotSameHandle
assertNumElements
assertReturnsTrue
assertSameHandle
assertSize
assertSubstring
assertThat
assertTrue
assertWarning
assertWarningFree
matlab.unittest.qualifications.AssertionFailedException
matlab.unittest.qualifications.Assumable
assumeClass
assumeEmpty
assumeEqual
assumeError
assumeFail
assumeFalse
assumeGreaterThan
assumeGreaterThanOrEqual
assumeInstanceOf
assumeLength
assumeLessThan
assumeLessThanOrEqual
assumeMatches
assumeNotEmpty
assumeNotEqual

assumeNotSameHandle
assumeNumElements
assumeReturnsTrue
assumeSameHandle
assumeSize
assumeSubstring
assumeThat
assumeTrue
assumeWarning
assumeWarningFree
matlab.unittest.qualifications.AssumptionFailedException
matlab.unittest.qualifications.ExceptionEventData
matlab.unittest.qualifications.FatalAssertable
fatalAssertClass
fatalAssertEmpty
fatalAssertEqual
fatalAssertError
fatalAssertFail
fatalAssertFalse
fatalAssertGreaterThan
fatalAssertGreaterThanOrEqual
fatalAssertInstanceOf
fatalAssertLength
fatalAssertLessThan
fatalAssertLessThanOrEqual
fatalAssertMatches
fatalAssertNotEmpty
fatalAssertNotEqual
fatalAssertNotSameHandle
fatalAssertNumElements
fatalAssertReturnsTrue
fatalAssertSameHandle
fatalAssertSize
fatalAssertSubstring
fatalAssertThat
fatalAssertTrue
fatalAssertWarning

fatalAssertWarningFree
matlab.unittest.qualifications.FatalAssertionFailedException
matlab.unittest.qualifications.QualificationEventData
matlab.unittest.qualifications.Verifiable
verifyClass
verifyEmpty
verifyEqual
verifyError
verifyFail
verifyFalse
verifyGreaterThan
verifyGreaterThanOrEqual
verifyInstanceOf
verifyLength
verifyLessThan
verifyLessThanOrEqual
verifyMatches
verifyNotEmpty
verifyNotEqual
verifyNotSameHandle
verifyNumElements
verifyReturnsTrue
verifySameHandle
verifySize
verifySubstring
verifyThat
verifyTrue
verifyWarning
verifyWarningFree
questdlg
quit
Quit (COM)
quiver
quiver3
Quivergroup Properties
qz
rand

rand (RandStream)
randi
randi (RandStream)
randn
randn (RandStream)
randperm
randperm (RandStream)
RandStream
RandStream constructor
RandStream.getGlobalStream
RandStream.setGlobalStream
rank
rat
rats
rbbox
rcond
rdivide, ./
read
read
readasync
readEncodedStrip
readEncodedTile
readRGBImage
readRGBAStrip
readRGBATile
Remove
RemoveAll
timeseries
addsample
append
ctranspose
delsample
detrend
filter
get
getabstime
getdatasamples

getdatasamplesize
getinterpmethod
getqualitydesc
getsamples
getsamplesusingtime
idealfilter
iqr
max
mean
median
min
plot
resample
set
setabstime
setinterpmethod
setuniformtime
synchronize
transpose
std
sum
var
triangulation
barycentricToCartesian
cartesianToBarycentric
circumcenter
edgeAttachments
edges
faceNormal
featureEdges
freeBoundary
incenter
isConnected
neighbors
size
vertexAttachments
vertexNormal

readtable
real
realloc
realmax
realmin
realpow
realsqrt
record
record
recordblocking
rectangle
Rectangle Properties
rectint
recycle
reducepatch
reducevolume
refresh
refreshdata
regexp
regexpi
regexprep
regxptranslate
registerevent
rehash
release
Relational Operators (handle)
rem
remove
removecats
removets
renamecats
reordercats
rename
repmat
resample (tscollection)
reset
reset (RandStream)

reshape
residue
restoredefaultpath
rethrow
rethrow (MException)
return
rewriteDirectory
rgb2hsv
rgb2ind
rgbplot
ribbon
rmappdata
rmdir
rmdir
rmfield
rmpath
rmpref
rng
root object
Root Properties
roots
rose
rosser
rot90
rotate
rotate3d
round
rowfun
rref
rsf2csf
run
runtests
save
save (COM)
save (serial)
saveas
savefig

saveobj
savepath
scatter
scatter3
Scattergroup Properties
schur
script
scatteredInterpolant
sec
secd
sech
selectmoveresize
matlab.unittest.selectors
matlab.unittest.selectors.HasParameter
matlab.unittest.selectors.HasSharedTestFixture
matlab.unittest.selectors.HasBaseFolder
matlab.unittest.selectors.HasName
semilogx
semilogy
sendmail
serial
serialbreak
set
set
set
set (COM)
set (hgsetget)
set
set (RandStream)
set (serial)
set (tscollection)
setabstime (tscollection)
setappdata
setdiff
setDirectory
setdisp (hgsetget)
setenv

setfield
setpixelposition
setpref
setstr
setSubDirectory
setTag
settimeseriesnames
setxor
shading
shg
shiftdim
showplottool
shrinkfaces
sign
sin
sind
single
sinh
size
size
size
size (serial)
size
size (tscollection)
slice
smooth3
snapnow
sort
sortrows
sound
soundsc
spalloc
sparse
spaugment
spconvert
spdiags
specular

speye
spfun
sph2cart
sphere
spinmap
spline
spones
spparms
sprand
sprandn
sprandsym
sprank
sprintf
spy
sqrt
sqrtm
squeeze
ss2tf
sscanf
stack
stairs
Stairseries Properties
standardizeMissing
startup
std
stem
stem3
Stemseries Properties
stopasync
str2double
str2func
str2mat
str2num
strcat
strcmp
strcmpi
stream2

stream3
streamline
streamparticles
streamribbon
streamslice
streamtube
strfind
strings
strjoin
strjust
strmatch
strncmp
strncmpi
stread
strep
strsplit
strtok
strtrim
struct
struct2cell
struct2table
structfun
strvcat
sub2ind
subplot
subsasgn
subsindex
subspace
subsref
substruct
subvolume
sum
summary
superclasses
superiorto
support
surf

surf
surf2patch
surface
Surface Properties
Surfaceplot Properties
surf1
surfnorm
svd
svds
swapbytes
switch, case, otherwise
sylvester
symamd
symbfact
symmlq
symrcm
symvar
syntax
system
table
table2array
table2cell
table2struct
Table Properties
tan
tand
tanh
tar
tempdir
tempname
tetramesh
matlab.unittest.Test
matlab.unittest.TestCase
addTeardown
applyFixture
forInteractiveUse
getSharedTestFixtures

run
matlab.unittest.TestResult
matlab.unittest.TestRunner
addPlugin
run
withNoPlugins
withTextOutput
matlab.unittest.TestSuite
fromClass
fromFile
fromFolder
fromMethod
fromName
fromPackage
run
selectIf
texlabel
text
Text Properties
textread
textscan
textwrap
tfqmr
throw (MException)
throwAsCaller (MException)
tic
timeit
toc
Tiff
timer
delete
get
isvalid
set
start
startat
stop

timerfind
timerfindall
wait
times, .*
title
todatenum
toeplitz
toolboxdir
trace
transpose
trapz
treelayout
treepplot
tril
trimesh
triplequad
triplot
TriRep
TriRep
TriScatteredInterp
TriScatteredInterp
trisurf
triu
true
try, catch
tscollection
tsdata.event
tsearchn
tstool
type
typecast
uibbuttongroup
Uibuttongroup Properties
uicontextmenu
Uicontextmenu Properties
uicontrol
Uicontrol Properties

uigetdir
uigetfile
uigetpref
uiimport
uimenu
Uimenu Properties
uint8
uint16
uint32
uint64
uiopen
uipanel
Uipanel Properties
uipushtool
Uipushtool Properties
uiputfile
uiresume
uisave
uisetcolor
uisetfont
uisetpref
uistack
uitable
Uitable Properties
uitoggletool
Uitoggletool Properties
uitoolbar
Uitoolbar Properties
uiwait
uminus, -
undocheckout
unicode2native
union
unique
matlab.unittest
unix
unloadlibrary

unmesh
unmkpp
unregisterallevents
unregisterevent
unstack
untar
unwrap
unzip
uplus, +
upper
urlread
urlwrite
usejava
userpath
validateattributes
validatestring
values
vander
var
varargin
varargout
varfun
vectorize
ver
verctrl
verLessThan
version
vertcat
vertcat (tscollection)
vertexAttachments
VideoReader
VideoWriter
view
viewmtx
visdiff
volumebounds
voronoi

voronoiDiagram
voronoin
waitbar
waitfor
waitforbuttonpress
warndlg
warning
waterfall
wavinfo
wavplay
wavread
wavrecord
wavwrite
web
weekday
what
whatsnew
which
while
whitebg
who
who
whos
whos
width
wilkinson
winopen
winqueryreg
wk1info
wk1read
wk1write
workspace
writetable
write
writeDirectory
writeEncodedStrip
writeEncodedTile

writeVideo
xlabel
ylabel
zlabel
xlim
ylim
zlim
xlsfinfo
xlsread
xlswrite
xmlread
xmlwrite
xor
xslt
zeros
zip
zoom
closePreview
preview
snapshot
webcam
webcamlist

Relational Operators < > <= >= == ~=

Purpose Relational operations

Syntax

```
A < B
A > B
A <= B
A >= B
A == B
A ~= B
```

Description The relational operators are <, >, <=, >=, ==, and ~=. Relational operators perform element-by-element comparisons between two arrays. They return a logical array of the same size, with elements set to logical 1 (true) where the relation is true, and elements set to logical 0 (false) where it is not.

The operators <, >, <=, and >= use only the real part of their operands for the comparison. The operators == and ~= test real and imaginary parts.

To test if two strings are equivalent, use strcmp, which allows vectors of dissimilar length to be compared.

Note For some toolboxes, the relational operators are overloaded, that is, they perform differently in the context of that toolbox. To see the toolboxes that overload a given operator, type help followed by the operator name. For example, type help lt. The toolboxes that overload lt (<) are listed. For information about using the operator in that toolbox, see the documentation for the toolbox.

Examples If one of the operands is a scalar and the other a matrix, the scalar expands to the size of the matrix. For example, the two pairs of statements

```
X = 5; X >= [1 2 3; 4 5 6; 7 8 10]
X = 5*ones(3,3); X >= [1 2 3; 4 5 6; 7 8 10]
```

produce the same result:

```
ans =
```

Relational Operators < > <= >= == !=

1	1	1
1	1	0
0	0	0

See Also

[all](#) | [any](#) | [find](#) | [strcmp](#) | [Logical Operators: Short Circuit](#)

Purpose Logical operations with short-circuiting

Syntax `expr1 && expr2`
`expr1 || expr2`

Description `expr1 && expr2` represents a logical AND operation that employs short-circuiting behavior. That is, `expr2` is not evaluated if `expr1` is logical 0 (false). Each expression must evaluate to a scalar logical result.

`expr1 || expr2` represents a logical OR operation that employs short-circuiting behavior. That is, `expr2` is not evaluated if `expr1` is logical 1 (true). Each expression must evaluate to a scalar logical result.

Examples **Use Scalar Logical Conditions**

Create two vectors.

```
X = [1 0 0 1 1];  
Y = [0 0 0 0 0];
```

Use the short-circuit OR operator with X and Y.

```
X || Y
```

Operands to the `||` and `&&` operators must be convertible to logical scalars.

The short-circuit operators operate only with scalar logical conditions.

Use the `any` and `all` functions to reduce each vector to a single logical condition.

```
any(X) || any(Y)
```

```
ans =
```

```
1
```

Logical Operators: Short-Circuit && ||

The expression is equivalent to `1 || 0`, so it evaluates to logical 1 (true) after computing only the first condition, any(X).

Specify Dependent Logical Conditions

Specify a logical statement where the second condition depends on the first. In the following statement, it doesn't make sense to evaluate the relation on the right if the divisor, b, is zero.

```
b = 1;  
a = 20;  
x = (b ~= 0) && (a/b > 18.5)
```

```
x =
```

```
1
```

The result is logical 1 (true). However, if `(b ~= 0)` evaluates to false, MATLAB® assumes the entire expression to be false and terminates its evaluation of the expression early.

Specify `b = 0` and evaluate the same expression.

```
b = 0;  
x = (b ~= 0) && (a/b > 18.5)
```

```
x =
```

```
0
```

The result is logical 0 (false). The first statement evaluates to logical 0 (false), so the expression short-circuits.

Change Structure Field Value

Create a structure with fields named 'File' and 'Format'.

```
S = struct('File',{'myGraph'},'Format',[])
```

```
S =
```

```
File: 'myGraph'  
Format: []
```

Short-circuit expressions are useful in *if* statements when you want multiple conditions to be true. The conditions can build on one another in such a way that it only makes sense to evaluate the second expression if the first expression is true.

Specify an *if* statement that executes only when *S* contains an empty field named 'Format'.

```
if isfield(S,'Format') && isempty(S.Format)  
    S.Format = '.png';  
end  
S  
  
S =
```

```
File: 'myGraph'  
Format: '.png'
```

The first condition tests if the string 'Format' is the name of a field in structure *S*. The second statement then tests whether the *Format* field is empty. The truth of the second condition depends on the first. The second condition can never be true if the first condition is not true. Since *S* has an empty field named 'Format', the body statement executes and assigns *S.Format* the value '.png'.

Definitions

Logical Short-Circuiting

With logical short-circuiting, the second operand, *expr2*, is evaluated only when the result is not fully determined by the first operand, *expr1*.

Due to the properties of logical AND and OR, the result of a logical expression is sometimes fully determined before evaluating all of the conditions. The logical and operator returns logical 0 (false) if even a single condition in the expression is false. The logical or operator returns logical 1 (true) if even a single condition in the expression is

Logical Operators: Short-Circuit && ||

true. When the evaluation of a logical expression terminates early by encountering one of these values, the expression is said to have *short-circuited*.

For example, in the expression `A && B`, MATLAB does not evaluate condition `B` at all if condition `A` is false. If `A` is false, then the value of `B` does not change the outcome of the operation.

When you use the element-wise `&` and `|` operators in the context of an `if` or `while` loop expression (and *only* in that context), they use short-circuiting to evaluate expressions.

Note Always use the `&&` and `||` operators to enable short-circuit evaluation. Using the `&` and `|` operators for short-circuiting can yield unexpected results when the expressions do not evaluate to logical scalars.

See Also

`all` | `any` | `find` | `logical` | `xor` | `true` | `false` | `and` | `or`

Concepts

- “Reduce Logical Arrays to Single Value”

Special Characters [] () { } = ' , ; : % ! @

Purpose

Special characters

Syntax

[]
{ }
()
=
'
.
...
,
;
:
%
%{ %}
!
@

Description

[] Brackets are used to form vectors and matrices. $[6.9 \ 9.64 \ \text{sqrt}(-1)]$ is a vector with three elements separated by blanks. $[6.9, \ 9.64, \ i]$ is the same thing. $[1+j \ 2-j \ 3]$ and $[1 \ +j \ 2 \ -j \ 3]$ are not the same. The first has three elements, the second has five.

$[11 \ 12 \ 13; \ 21 \ 22 \ 23]$ is a 2-by-3 matrix. The semicolon ends the first row.

Vectors and matrices can be used inside [] brackets. $[A \ B;C]$ is allowed if the number of rows of A equals the number of rows of B and the number of columns of A plus the number of columns of B equals the number of columns of C. This rule generalizes to allow fairly complicated constructions.

Special Characters [] () { } = ' , ; : % ! @

`A = []` stores an empty matrix in `A`. `A(m,:) = []` deletes row `m` of `A`. `A(:,n) = []` deletes column `n` of `A`. `A(n) = []` reshapes `A` into a column vector and deletes the `n`th element.

`[A1,A2,A3...]` = function assigns function output to multiple variables.

For the use of `[` and `]` on the left of an “=” in multiple assignment statements, see `lu`, `eig`, `svd`, and so on.

`{ }` Curly braces are used in cell array assignment statements. For example, `A(2,1) = {[1 2 3; 4 5 6]}`, or `A{2,2} = ('str')`. See `help paren` for more information about `{ }`.

`()` Parentheses are used to indicate precedence in arithmetic expressions in the usual way. They are used to enclose arguments of functions in the usual way. They are also used to enclose subscripts of vectors and matrices in a manner somewhat more general than usual. If `X` and `V` are vectors, then `X(V)` is `[X(V(1)), X(V(2)), ..., X(V(n))]`. The components of `V` must be integers to be used as subscripts. An error occurs if any such subscript is less than 1 or greater than the size of `X`. Some examples are

- `X(3)` is the third element of `X`.
- `X([1 2 3])` is the first three elements of `X`.

See `help paren` for more information about `()`.

If `X` has `n` components, `X(n: 1:1)` reverses them. The same indirect subscripting works in matrices. If `V` has `m` components and `W` has `n` components, then `A(V,W)` is the `m`-by-`n` matrix formed from the elements of `A` whose subscripts are the elements of `V` and `W`. For example, `A([1,5],:) = A([5,1],:)` interchanges rows 1 and 5 of `A`.

`=` Used in assignment statements. `B = A` stores the elements of `A` in `B`. `==` is the relational equals operator. See the Relational Operators page.

Special Characters [] () { } = ' , ; : % ! @

- ' Matrix transpose. X' is the complex conjugate transpose of X . $X.'$ is the nonconjugate transpose.
- Quotation mark. 'any text' is a vector whose components are the ASCII codes for the characters. A quotation mark within the text is indicated by two quotation marks.
- . Decimal point. $314/100$, 3.14 , and $.314e1$ are all the same.
- . Element-by-element operations. These are obtained using $.*$, $.^$, $./$, or $.\$. See the Arithmetic Operators page.
- . Field access. $S(m).f$ when S is a structure, accesses the contents of field f of that structure.
- .() Dynamic Field access. $S.(df)$ when S is a structure, accesses the contents of dynamic field df of that structure. Dynamic field names are defined at runtime.
- .. Parent folder. See `cd`.
- ... Continuation. Three or more periods at the end of a line continue the current function on the next line. Three or more periods before the end of a line cause the MATLAB software to ignore the remaining text on the current line and continue the function on the next line. This effectively makes a comment out of anything on the current line that follows the three periods. For an example, see “Continue Long Statements on Multiple Lines”.
- , Comma. Used to separate matrix subscripts and function arguments. Used to separate statements in multistatement lines. For multistatement lines, the comma can be replaced by a semicolon to suppress printing.
- ; Semicolon. Used inside brackets to end rows. Used after an expression or statement to suppress printing or to separate statements.
- : Colon. Create vectors, array subscripting, and for loop iterations. See `colon (:)` for details.

Special Characters [] () { } = ' , ; : % ! @

- % Percent. The percent symbol denotes a comment; it indicates a logical end of line. Any following text is ignored. MATLAB displays the first contiguous comment lines in a function or script file in response to a `help` command.
- %{
%} Percent-brace. The text enclosed within the `%{` and `%}` symbols is a comment block. Use these symbols to insert comments that take up more than a single line in your script of function code. Any text between these two symbols is ignored by MATLAB.

With the exception of whitespace characters, the `%{` and `%}` operators must appear alone on the lines that immediately precede and follow the block of help text. Do not include any other text on these lines.
- ! Exclamation point. Indicates that the rest of the input line is issued as a command to the operating system. See “Run External Commands, Scripts, and Programs” for more information.
- @ Function handle. MATLAB data type that is a handle to a function. See `function_handle (@)` for details.

Tips

Some uses of special characters have function equivalents, as shown:

Horizontal concatenation	<code>[A,B,C...]</code> <code>horzcat(A,B,C...)</code>
Vertical concatenation	<code>[A;B;C...]</code> <code>vertcat(A,B,C...)</code>
Subscript reference	<code>A(i,j,k...)</code> <code>subsref(A,S)</code> . See help <code>subsref</code> .
Subscript assignment	<code>A(i,j,k...)=B</code> <code>subsasgn(A,S,B)</code> . See help <code>subsasgn</code> .

Special Characters [] () { } = ' , ; : % ! @

Note For some toolboxes, the special characters are overloaded, that is, they perform differently in the context of that toolbox. To see the toolboxes that overload a given character, type `help` followed by the character name. For example, type `help transpose`. The toolboxes that overload `transpose` (`.`) are listed. For information about using the character in that toolbox, see the documentation for the toolbox.

See Also

“Array vs. Matrix Operations”

Concepts

- “Logical Operations”
- “Relational Operations”

colon (:)

Purpose

Create vectors, array subscripting, and for-loop iterators

Description

The colon is one of the most useful operators in MATLAB. It can create vectors, subscript arrays, and specify for iterations.

The colon operator uses the following rules to create regularly spaced vectors for scalar values i , j , and k :

$j:k$ is the same as $[j, j+1, j+2, \dots, j+m]$, where $m = \text{fix}(k-j)$. In the case where both j and k are integers, this is simply $[j, j+1, \dots, k]$. This syntax returns an empty matrix when $j > k$.

$j:i:k$ is the same as $[j, j+i, j+2i, \dots, j+m*i]$, where $m = \text{fix}((k-j)/i)$. This syntax returns an empty matrix when $i == 0$, $i > 0$ and $j > k$, or $i < 0$ and $j < k$.

If you specify nonscalar arrays, MATLAB interprets $j:i:k$ as $j(1):i(1):k(1)$.

You can use the colon to create a vector of indices to select rows, columns, or elements of arrays, where:

$A(:,j)$ is the j th column of A .

$A(i,:)$ is the i th row of A .

$A(:,:)$ is the equivalent two-dimensional array. For matrices this is the same as A .

$A(j:k)$ is $A(j), A(j+1), \dots, A(k)$.

$A(:,j:k)$ is $A(:,j), A(:,j+1), \dots, A(:,k)$.

$A(:,:,k)$ is the k th page of three-dimensional array A .

`A(i,j,k,:)` is a vector in four-dimensional array `A`. The vector includes `A(i,j,k,1)`, `A(i,j,k,2)`, `A(i,j,k,3)`, and so on.

`A(:)` is all the elements of `A`, regarded as a single column. On the left side of an assignment statement, `A(:)` fills `A`, preserving its shape from before. In this case, the right side must contain the same number of elements as `A`.

When you create a vector to index into a cell array or structure array (such as `cellName{:}` or `structName(:).fieldName`), MATLAB returns multiple outputs in a comma-separated list. For more information, see “How to Use the Comma-Separated Lists” in the MATLAB Programming Fundamentals documentation.

Examples

Using the colon with integers,

```
D = 1:4
```

results in

```
D =  
    1    2    3    4
```

Using two colons to create a vector with arbitrary real increments between the elements,

```
E = 0:.1:.5
```

results in

```
E =  
    0    0.1000    0.2000    0.3000    0.4000    0.5000
```

The command

```
A(:,:,2) = pascal(3)
```

colon (:)

generates a three-dimensional array whose first page is all zeros.

```
A(:,:,1) =  
    0    0    0  
    0    0    0  
    0    0    0
```

```
A(:,:,2) =  
    1    1    1  
    1    2    3  
    1    3    6
```

Using a colon with characters to iterate a for-loop,

```
for x='a':'d',x,end
```

results in

```
x =  
    a  
x =  
    b  
x =  
    c  
x =  
    d
```

See Also

[for](#) | [linspace](#) | [logspace](#) | [reshape](#) | [varargin](#)

Purpose Absolute value and complex magnitude

Syntax `abs(X)`

Description `abs(X)` returns an array Y such that each element of Y is the absolute value of the corresponding element of X.

If X is complex, `abs(X)` returns the complex modulus (magnitude), which is the same as

```
sqrt(real(X).^2 + imag(X).^2)
```

Examples

```
abs(-5)
ans =
    5
```

```
abs(3+4i)
ans =
    5
```

See Also `angle` | `sign` | `unwrap`

accumarray

Purpose Construct array with accumulation

Syntax

```
A = accumarray(subs, val)
A = accumarray(subs, val, sz)
A = accumarray(subs, val, sz, fun)
A = accumarray(subs, val, sz, fun, fillval)
A = accumarray(subs, val, sz, fun, fillval, issparse)
```

Description `A = accumarray(subs, val)` returns an array, `A`, by accumulating elements of vector `val` using the subscripts in `subs`. The values in each row of the m -by- n matrix `subs` define an n -dimensional subscript into the output, `A`. If `subs` is a column vector, the value in each row defines a row subscript into the output, which is also a column vector.

The i th row of `subs` corresponds to the i th element in the vector, `val`. The function collects all elements of `val` that have identical subscripts in `subs`, applies the function `@sum`, and then stores the result in the location of `A` corresponding to the subscript. Elements of `A` that are not referred to by any row of `subs` contain the value 0.

`A = accumarray(subs, val, sz)` returns an array, `A`, with size `sz`. Specify `sz` as a vector of positive integers to define the size of the output, or as `[]` to let the subscripts in `subs` determine the size of the output. Use `sz` when `subs` does not reference trailing rows, columns, or dimensions that you would like to be present in the output.

`A = accumarray(subs, val, sz, fun)` applies the function `fun` to each subset of elements in `val` that have identical subscripts in `subs`. Specify `fun` using the `@` symbol (e.g., `@mean`), or as `[]` to use the default function, `@sum`.

`A = accumarray(subs, val, sz, fun, fillval)` fills all elements of `A` that are not referred to by any subscript in `subs` with the scalar value, `fillval`. The `fillval` input must have the same class as the values returned by `fun`. Specify `fillval` as `[]` to use the default value, 0.

`A = accumarray(subs, val, sz, fun, fillval, issparse)` returns an array, `A`, that is sparse if the scalar `issparse` is true or 1, and full if `issparse` is false or 0. The output, `A`, is full by default.

Input Arguments

subs - Subscript matrix

vector of indices | matrix of indices | cell array of index vectors

Subscript matrix, specified as a vector of indices, matrix of indices, or cell array of index vectors. The indices must be positive integers:

- The value in each row of the m -by- n matrix, `subs`, specifies an n -dimensional index into the output, `A`. For example, if `subs` is a 3-by-2 matrix, it contains three 2-D subscripts. `subs` also can be a column vector of indices, in which case the output, `A`, is also a column vector.
- The i th row in `subs` corresponds to the i th data value in `val`.

Thus, `subs` determines which data in `val` to group, as well as its final destination in the output. If `subs` is a cell array of index vectors, each vector must have the same length, and the function treats the vectors as columns of a subscript matrix.

val - Data

vector | scalar

Data, specified as a vector or scalar:

- If `val` is a vector, it must have the same length as the number of rows in `subs`.
- If `val` is a scalar, it is scalar expanded.

In both cases, a one-to-one pairing is present between the subscripts in each row of `subs` and the data values in `val`.

Data Types

single | double | int8 | int16 | int32 | int64 | uint8 | uint16 | uint32 | uint64 | logical | char

Complex Number Support: Yes

sz - Size of output array

vector of positive integers | [] (default)

Size of output array, specified as a vector of positive integers or [] (default). When you specify [] for the default size, the values in `subs` determine the size of the output array, `A`.

When you specify `sz` as a vector of positive integers, it must satisfy these properties:

- If `subs` is a nonempty m -by- n matrix with $n > 1$ columns, then `sz` must have n elements and pass the logical test `all(sz >= max(subs, [], 1))`.
- If `subs` is a nonempty column vector, then `sz` must be `[m 1]` where $m \geq \max(\text{subs})$.

Example: `sz = [3 3]`

fun - Function

function handle | [] (default)

Function, specified as a function handle or [] (default). The default function is `@sum`. The `fun` function must accept a column vector and return a numeric, logical, or char scalar, or a scalar cell. If the subscripts in `subs` are not sorted with respect to their linear indices, `fun` should not depend on the order of the values in its input data.

Example: `fun = @max`

Data Types

function_handle

fillval - Fill value

scalar | [] (default)

Fill value, specified as a scalar or [] (default). The default value of `fillval` is 0. If `subs` does not reference each element in the output, `accumarray` fills in the output with the value specified by `fillval`. The class of `fillval` must be the same as the values returned by `fun`.

issparse - Output sparsity

false (default) | true | 1 | 0

Output sparsity, specified as true, 1, 0, or false (default). Specify true or 1 when you want the output array to be sparse. If issparse is true or 1:

- fillval must be 0 or [].
- The values in val and the output values of fun must both have type double.

Output Arguments

A - Output array

vector | matrix | multidimensional array

Output array, returned as a vector, matrix, or multidimensional array. A has the same class as the values returned by fun.

When sz is not specified, the size of A depends on the input subs:

- If subs is a nonempty matrix with $n > 1$ columns, then A is an n -dimensional array of size $\max(\text{subs}, [], 1)$.
- If subs is an empty matrix with $n > 1$ columns, then A is an n -dimensional empty array with size 0-by-0-by-...-by-0.
- If subs is a nonempty column vector, then A is a column vector of length $\max(\text{subs}, [], 1)$. The length of A is 0 when subs is empty.

Examples

Find Bin Counts

Create a vector of subscripts, subs.

```
subs = [1; 2; 4; 2; 4]
```

```
subs =
     1
     2
     4
     2
     4
```

accumarray

Use `accumarray` with `val = 1` to count the number of identical subscripts in `subs`.

```
A = accumarray(subs,1)
```

```
A =
```

```
1
2
0
2
```

The result is a vector of bin counts. You can obtain the same answer with `histc(subs,1:4)`. However, `accumarray` also can compute bin counts over higher dimensional grids.

Accumulate Data

Create a vector of data, `val`, and a vector of subscript values with the same length, `subs`.

```
val = 101:105';
subs = [1; 3; 4; 3; 4]
```

```
subs =
```

```
1
3
4
3
4
```

Use `accumarray` to sum the values in `val` that have identical subscripts in `subs`.

```
A = accumarray(subs,val)
```

```
A =
```

```

101
  0
206
208

```

The result is a vector of accumulated values. Since the second and fourth elements of `subs` are equal to 3, $A(3)$ is the sum of the second and fourth elements of `val`, that is, $A(3) = 102 + 104 = 206$. Also, $A(2) = 0$ because `subs` does not contain the value 2. Since `subs` is a vector, the output, `A`, is also a vector. The length of `A` is $\max(\text{subs}, [], 1)$.

Specify Output Size

Create a vector of data, `val`, and a matrix of subscripts, `subs`.

```

val = 101:106';
subs = [1 1; 2 2; 3 2; 1 1; 2 2; 4 1]

```

```

subs =

     1     1
     2     2
     3     2
     1     1
     2     2
     4     1

```

The subscripts in `subs` define a 4-by-2 matrix for the output.

Use `accumarray` to sum the values in `val` that have identical subscripts in `subs`.

```

A = accumarray(subs, val)

```

```

A =

    205     0
     0    207
     0    103

```

accumarray

```
106    0
```

The result is a 4-by-2 matrix of accumulated values.

Use the `sz` input of `accumarray` to return a 4-by-4 matrix. You can specify a size with each dimension equal to or greater than the default size, in this case 4-by-2, but not smaller.

```
A = accumarray(subs, val, [4 4])
```

```
A =
```

```
205    0    0    0
    0   207    0    0
    0   103    0    0
106    0    0    0
```

The result is a 4-by-4 matrix of accumulated values.

Use Custom Functions

Create a vector of data, `val`, and a matrix of subscripts, `subs`.

```
val = [100.1 101.2 103.4 102.8 100.9 101.5]';
subs = [1 1; 1 1; 2 2; 3 2; 2 2; 3 2]
```

```
subs =
```

```
1    1
1    1
2    2
3    2
2    2
3    2
```

The subscripts in `subs` define a 3-by-2 matrix for the output.

Use the fun input of `accumarray` to calculate the within-group variances of data in `val` that have identical subscripts in `subs`. Specify `fun` as `@var`.

```
A1 = accumarray(subs, val, [], @var)
```

```
A1 =
```

```
    0.6050         0
         0    3.1250
         0    0.8450
```

The result is a 3-by-2 matrix of variance values.

Alternatively, you can specify `fun` as an anonymous function so long as it accepts vector inputs and returns a scalar. A common situation where this is useful is when you want to pass additional parameters to a function. In this case, use the `var` function with a normalization parameter.

```
A2 = accumarray(subs, val, [], @(x) var(x, 1))
```

```
A2 =
```

```
    0.3025         0
         0    1.5625
         0    0.4225
```

The result is a 3-by-2 matrix of normalized variance values.

Sum Values Natively

Create a vector of data, `val`, and a matrix of subscripts, `subs`.

```
val = int8(10:15);
subs = [1 1 1; 1 1 1; 1 1 2; 1 1 2; 2 3 1; 2 3 2]
```

```
subs =
```

accumarray

```
1     1     1
1     1     1
1     1     2
1     1     2
2     3     1
2     3     2
```

The subscripts in `subs` define a 2-by-3-by-2 multidimensional array for the output.

Use `accumarray` to sum the data values in `val` that have identical subscripts in `subs`. You can use a function handle to sum the values in their native, `int8`, integer class by using the 'native' option of the `sum` function.

```
A = accumarray(subs,val,[],@(x) sum(x,'native'))
```

```
A(:,:,1) =
```

```
21     0     0
 0     0    14
```

```
A(:,:,2) =
```

```
25     0     0
 0     0    15
```

The result is a 2-by-3-by-2 multidimensional array of class `int8`.

Group Values in Cell Array

Create a vector of data, `val`, and a matrix of subscripts, `subs`.

```
val = 1:10;
subs = [1 1;1 1;1 1;1 1;2 1;2 1;2 1;2 1;2 1;2 1;2 2]
```

```
subs =
```



```

1     1
1     1
1     1
1     1
2     1
2     1
2     1
2     1
2     1
2     1
2     2

```

The subscripts in `subs` define a 2-by-2 matrix for the output.

Use `accumarray` to group the elements of `val` into a cell array.

```
A = accumarray(subs, val, [], @(x) {x})
```

```
A =
```

```

[4x1 double]     []
[5x1 double]     [10]

```

The result is a 2-by-2 cell array.

Verify that the vector elements are in the same order as they appear in `val`.

```
A{2,1}
```

```
ans =
```

```

5
6
7
8
9

```

Since the subscripts in `subs` are sorted, the elements of the numeric vectors in the cell array are in the same order as they appear in `val`.

Using Functions That Depend on Data Order

Create a vector of data, `val`, and a matrix of subscripts, `subs`.

```
val = 1:5;  
subs = [1 2; 1 1; 1 2; 1 1; 2 3]
```

```
subs =  
  
     1     2  
     1     1  
     1     2  
     1     1  
     2     3
```

The subscripts in `subs` define a 2-by-3 matrix for the output, but are unsorted with respect to the linear indices in the output, `A`.

Group the values in `val` into a cell array by specifying `fun = @(x) {x}`.

```
A = accumarray(subs, val, [], @(x) {x})
```

```
A =  
  
     [2x1 double]     [2x1 double]     []  
     []           []           [5]
```

The result is a 2-by-3 cell array.

Examine the vector in `A{1,2}`.

```
A{1,2}
```

```
ans =  
  
     3
```

```
1
```

The elements of the `A{1,2}` vector are in a different order than in `val`. The first element of the vector is 3 instead of 1. If the subscripts in `subs` are not sorted with respect to their linear indices, then `accumarray` might not always preserve the order of the data in `val` when it passes them to `fun`. In the unusual case that `fun` requires that its input values be in the same order as they appear in `val`, sort the indices in `subs` with respect to the linear indices of the output.

Use the two-output syntax of the `sortrows` function to reorder `subs` and `val` concurrently with respect to the linear indices of the output, `A`.

```
[S,I] = sortrows(subs);
A = accumarray(S,val(I),[],@(x) {x});
A{3}
```

```
ans =
```

```
1
3
```

The elements of the `A{3}` vector are now in sorted order.

Fill Output with NaN Values

Create a vector of data, `val`, and a matrix of subscripts, `subs`.

```
val = 101:106';
subs = [1 1; 2 2; 3 3; 1 1; 2 2; 4 4]
```

```
subs =
```

```
1 1
2 2
3 3
1 1
2 2
4 4
```

accumarray

The subscripts in `subs` define a 4-by-4 matrix for the output, but only reference 4 out of the 16 elements. By default, the other 12 elements are 0 in the output.

Use the `fillval` input of `accumarray` to fill in the extra output elements with NaN values.

```
A = accumarray(subs, val, [], [], NaN)
```

```
A =
```

```
    205    NaN    NaN    NaN
    NaN    207    NaN    NaN
    NaN    NaN    103    NaN
    NaN    NaN    NaN    106
```

The result is a 4-by-4 matrix padded with NaN values.

Change Output Sparsity

Create a vector of data, `val`, and a matrix of subscripts, `subs`.

```
val = [34 22 19 85 53 77 99 6];
subs = [1 1; 400 400; 80 80; 1 1; 400 400; 400 400; 80 80; 1 1]
```

```
subs =
```

```
     1     1
   400   400
     80    80
     1     1
   400   400
   400   400
     80    80
     1     1
```

The subscripts in `subs` define a 400-by-400 matrix for the output, but only reference 3 out of the 160,000 elements. When the result of an operation with `accumarray` leads to a large output array with low

density of nonzero elements, you can save storage space by storing the output as a sparse matrix.

Use the `issparse` input of `accumarray` to return a sparse matrix.

```
A = accumarray(subs, val, [], [], [], true)
```

```
A =
```

```

(1,1)      125
(80,80)     118
(400,400)   152

```

The result is a sparse matrix. You can obtain the same answer with `sparse(subs(:,1), subs(:,2), val)`.

Definitions

Accumulating Elements

The following graphic illustrates the behavior of `accumarray` on a vector of temperature data taken over a 12-month period. To find the maximum temperature reading for each month, `accumarray` applies the `max` function to each group of values in `temperature` that have identical subscripts in `month`.

accumarray

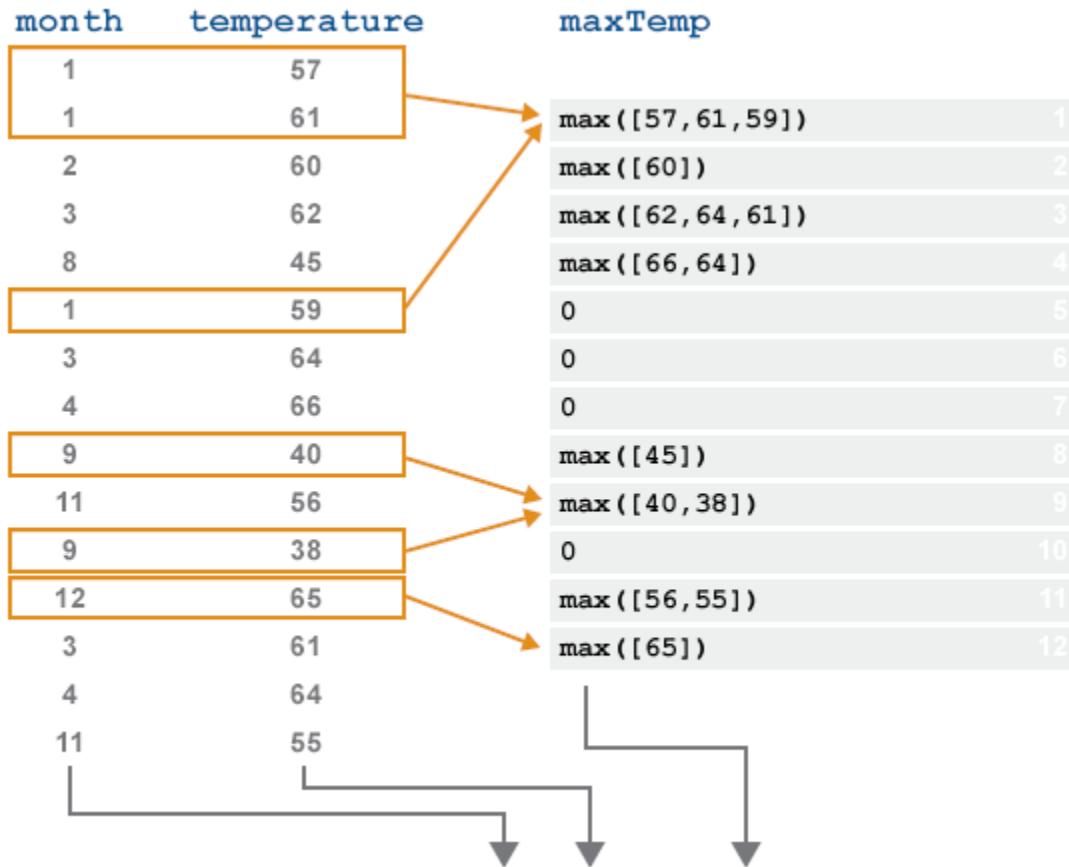

```
maxTemp = accumarray(subs, val, [], @max)
```

No values in month point to the 5, 6, 7, or 10 positions of the output. These elements are 0 in the output by default, but you can specify a value to fill in using fillval.

Tips

- The behavior of accumarray is similar to that of the histc function. Both functions group data into bins.

- `histc` groups continuous values into a 1-D range using bin edges.
- `accumarray` groups data using n -dimensional subscripts.
- `histc` returns the bin counts using `@sum`.
- `accumarray` can apply any function to the bins.

You can mimic the behavior of `histc` using `accumarray` with `val = 1`.

- The `sparse` function also has accumulation behavior similar to that of `accumarray`.
 - `sparse` groups data into bins using 2-D subscripts, whereas `accumarray` groups data into bins using n -dimensional subscripts.
 - `sparse` adds elements that have identical subscripts into the output. `accumarray` adds elements that have identical subscripts into the output by default, but can optionally apply any function to the bins.

See Also

`full` | `sparse` | `sum` | `function_handle` | `histc`

Purpose Inverse cosine in radians

Syntax $Y = \text{acos}(X)$

Description $Y = \text{acos}(X)$ returns the inverse cosine (arccosine) for each element of X . For real elements of X in the domain $[-1, 1]$, $\text{acos}(X)$ is real and in the range $[0, \pi]$. For real elements of X outside the domain $[-1, 1]$, $\text{acos}(X)$ is complex.

The `acos` function operates element-wise on arrays. The function's domains and ranges include complex values. All angles are in radians.

Examples **Graph of Inverse Cosine Function**

Graph the inverse cosine function over the domain $-1 \leq x \leq 1$.

```
x = -1:.05:1;  
plot(x,acos(x)), grid on
```

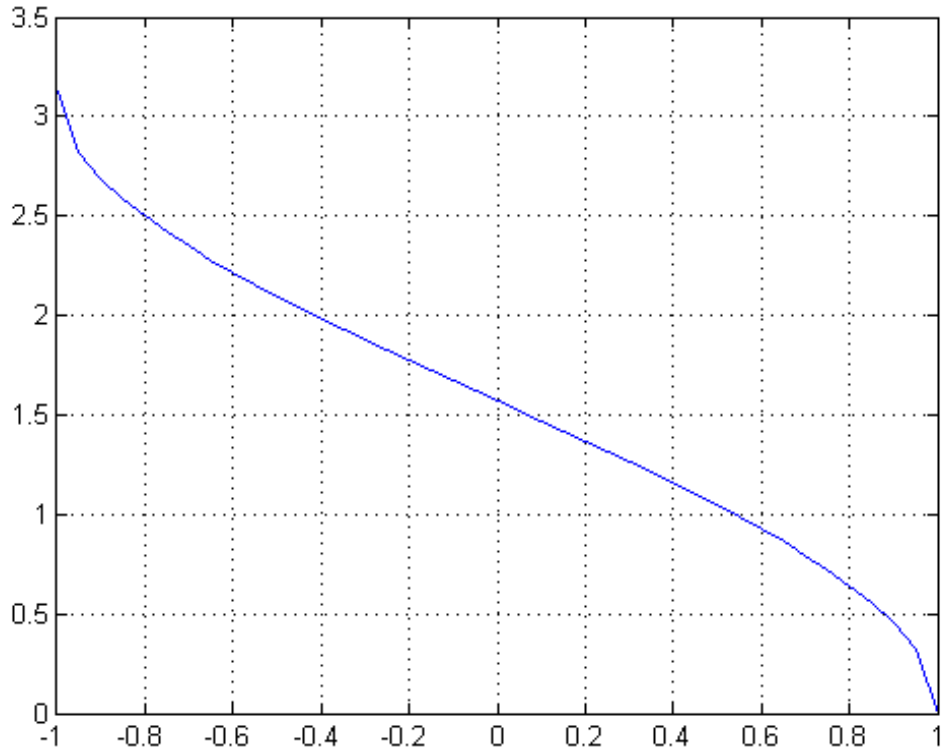
Definitions Inverse Cosine

The inverse can be defined as

$$\cos^{-1}(z) = -i \log \left[z + i(1 - z^2)^{1/2} \right].$$

See Also `acosd` | `acosh` | `cos`

acosd

Purpose Inverse cosine in degrees

Syntax $Y = \text{acosd}(X)$

Description $Y = \text{acosd}(X)$ returns the inverse cosine (\cos^{-1}) of the elements of X in degrees. The function's domain and range include complex values. For real elements of X in the domain $[-1,1]$, acosd returns values in the range $[0, 180]$. For values of X outside this range, acosd returns complex values.

Input Arguments **X - Cosine of angle**
scalar value | vector | matrix | N-D array

Cosine of angle, specified as a real-valued or complex-valued scalar, vector, matrix, or N-D array. The acosd operation is element-wise when X is non-scalar.

Data Types

single | double

Complex Number Support: Yes

Output Arguments **Y - Angle in degrees**
scalar value | vector | matrix | N-D array

Angle in degrees, returned as a real-valued or complex-valued scalar, vector, matrix, or N-D array of the same size as X .

Examples **Inverse Cosine of 0**

Verify that inverse cosine of 0 is exactly 90.

```
acosd(0)
```

```
ans =
```

```
90
```

Round-Trip Calculation for Complex Angles

Show that the inverse cosine, followed by cosine, returns the original values of X.

```
cosd(acosd([2 3]))
```

```
ans =
```

```
2.0000 3.0000
```

`acosd([2 3])` returns two complex angles, which are then passed to the `cosd` function. `cosd` returns the original values, 2 and 3.

See Also

`cosd` | `acos` | `cos`

acosh

Purpose Inverse hyperbolic cosine

Syntax $Y = \text{acosh}(X)$

Description $Y = \text{acosh}(X)$ returns the inverse hyperbolic cosine for each element of X .

The `acosh` function operates element-wise on arrays. The function's domains and ranges include complex values. All angles are in radians.

Examples **Graph of Inverse Hyperbolic Cosine Function**

Graph the inverse hyperbolic cosine function over the domain $-1 \leq x \leq \pi$.

```
x = 1:pi/40:pi;  
plot(x,acosh(x)), grid on
```

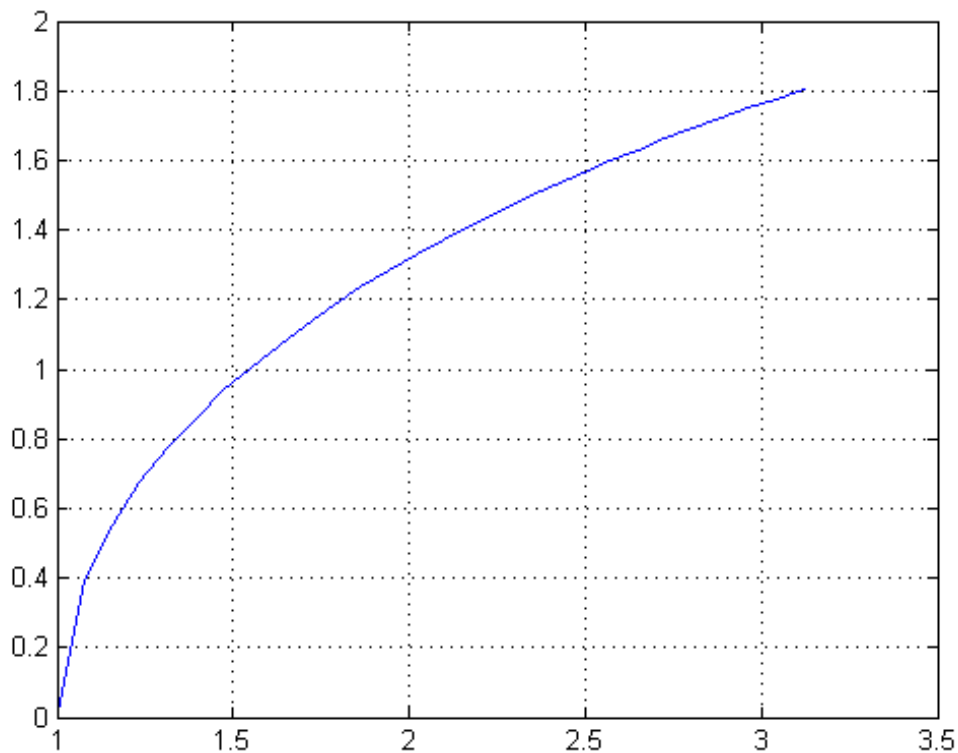
**Definitions** **Inverse Hyperbolic Cosine**

The inverse hyperbolic cosine can be defined as

$$\cosh^{-1}(z) = \log \left[z + (z^2 - 1)^{1/2} \right].$$

See Also [acos](#) | [cosh](#) | [asinh](#) | [atanh](#)

acot

Purpose Inverse cotangent in radians

Syntax $Y = \text{acot}(X)$

Description $Y = \text{acot}(X)$ returns the inverse cotangent (arccotangent) for each element of X .

The `acot` function operates element-wise on arrays. The function's domains and ranges include complex values. All angles are in radians.

Examples **Graph of Inverse Cotangent Function**

Graph the inverse cotangent function over the domains $-2\pi \leq x < 0$ and $0 < x \leq 2\pi$.

```
x1 = -2*pi:pi/30:-0.1;  
x2 = 0.1:pi/30:2*pi;  
plot(x1,acot(x1),x2,acot(x2)), grid on
```

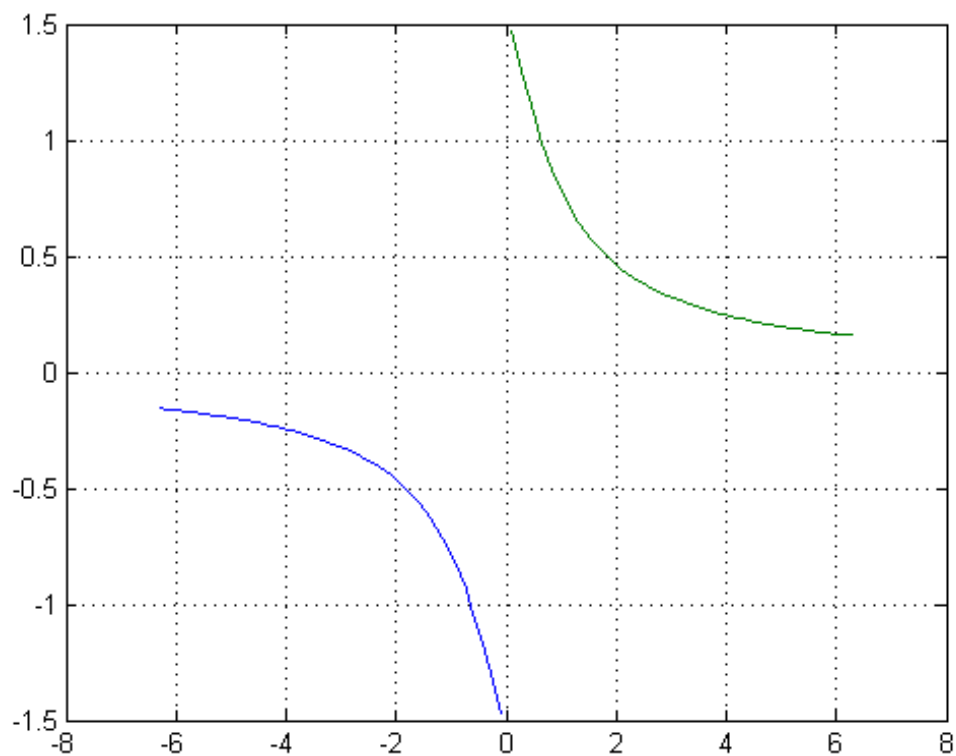
**Definitions** **Inverse Cotangent**

The inverse cotangent can be defined as

$$\cot^{-1}(z) = \tan^{-1}\left(\frac{1}{z}\right).$$

See Also [cot](#) | [acotd](#) | [acoth](#)

acotd

Purpose Inverse cotangent in degrees

Syntax $Y = \text{acotd}(X)$

Description $Y = \text{acotd}(X)$ returns the inverse cotangent (\cot^{-1}) of the elements of X in degrees. The function's domain and range include complex values. For real elements of X in the range $[-\text{Inf}, \text{Inf}]$, acotd returns values in the range $[-90, 90]$. For complex values of X , acotd returns complex values.

Input Arguments **X - Cotangent of angle**
scalar value | vector | matrix | N-D array

Cotangent of angle, specified as a real-valued or complex-valued scalar, vector, matrix, or N-D array. The acotd operation is element-wise when X is non-scalar.

Data Types

single | double

Complex Number Support: Yes

Output Arguments **Y - Angle in degrees**
scalar value | vector | matrix | N-D array

Angle in degrees, returned as a real-valued or complex-valued scalar, vector, matrix, or N-D array of the same size as X .

Examples **Inverse Cotangent of Vector**

```
x = [0 20 Inf];
```

```
y = acotd(x)
```

```
y =
```

```
    90.0000    2.8624         0
```

The acotd operation is element-wise when you pass a vector, matrix, or N-D array.

Inverse Cotangent of Complex Value`acotd(1+i)``ans =``31.7175 -23.0535i`**See Also**`cotd | cot | acot`

acoth

Purpose Inverse hyperbolic cotangent

Syntax $Y = \operatorname{acoth}(X)$

Description $Y = \operatorname{acoth}(X)$ returns the inverse hyperbolic cotangent for each element of X .
The `acoth` function operates element-wise on arrays. The function's domains and ranges include complex values. All angles are in radians.

Examples **Graph of Inverse Hyperbolic Cotangent Function**

Graph the inverse hyperbolic cotangent function over the domains $-30 \leq x < -1$ and $1 < x \leq 30$.

```
x1 = -30:0.1:-1.1;  
x2 = 1.1:0.1:30;  
plot(x1,acoth(x1),x2,acoth(x2)), grid on
```

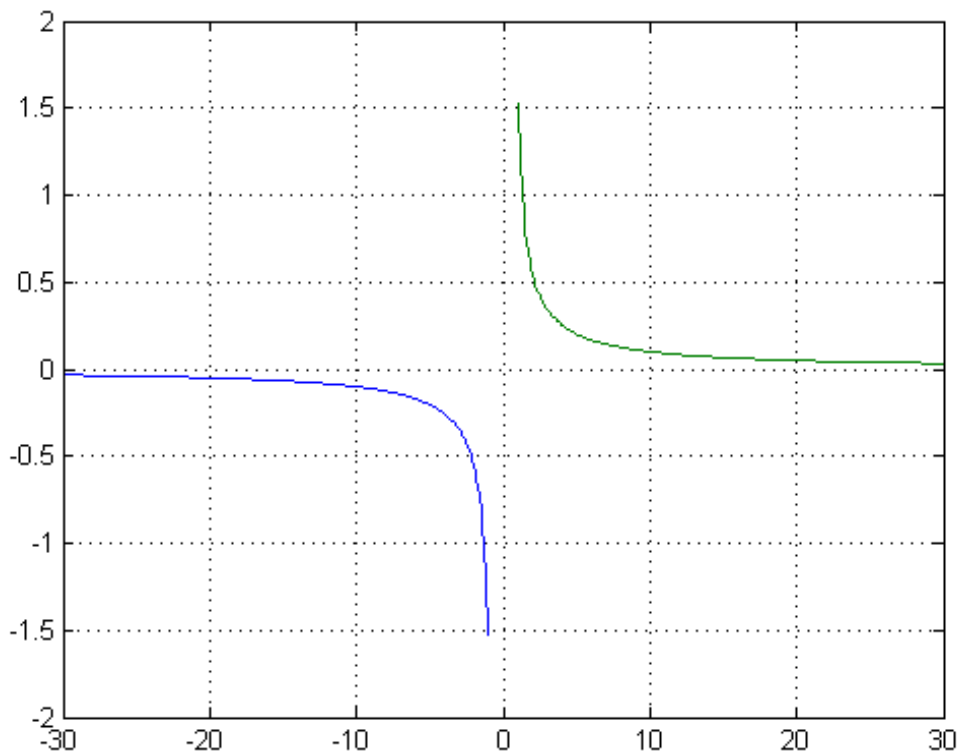

Definitions Inverse Hyperbolic Cotangent

The inverse hyperbolic cotangent can be defined as

$$\operatorname{coth}^{-1}(z) = \tanh^{-1}\left(\frac{1}{z}\right).$$

See Also `acot` | `coth` | `atanh` | `asinh` | `acosh`

Purpose Inverse cosecant in radians

Syntax $Y = \text{acsc}(X)$

Description $Y = \text{acsc}(X)$ returns the inverse cosecant (arccosecant) for each element of X .

The `acsc` function operates element-wise on arrays. The function's domains and ranges include complex values. All angles are in radians.

Examples **Graph of Inverse Cosecant Function**

Graph the inverse cosecant function over the domains $-10 \leq x < -1$ and $1 < x \leq 10$.

```
x1 = -10:0.01:-1.01;  
x2 = 1.01:0.01:10;  
plot(x1,acsc(x1),x2,acsc(x2)), grid on
```

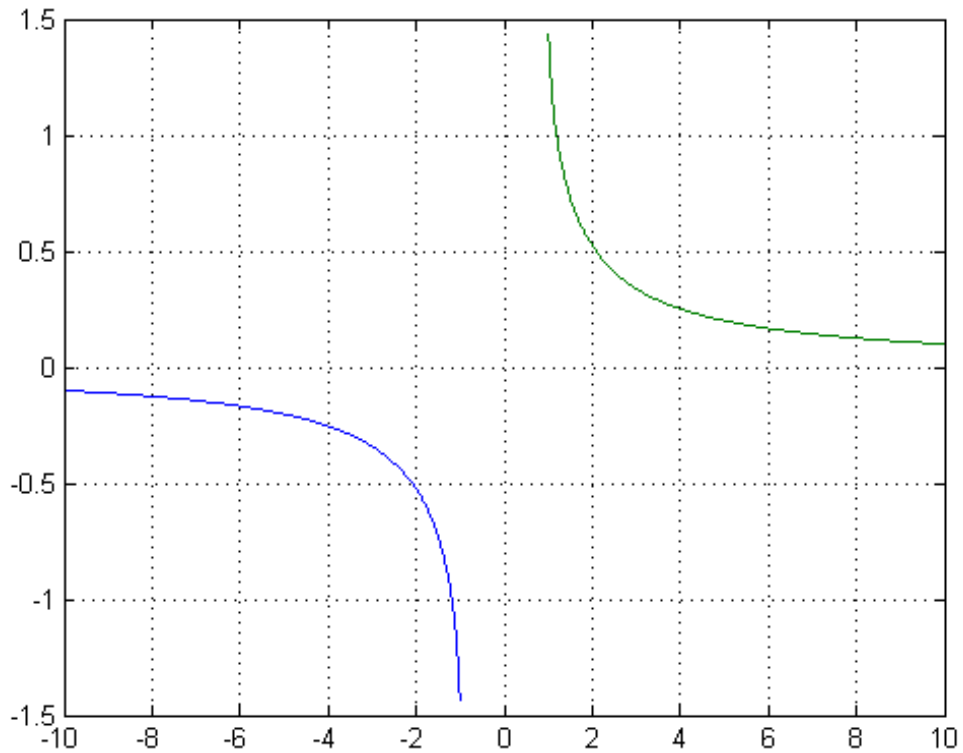
**Definitions** **Inverse Cosecant**

The inverse cosecant can be defined as

$$\text{csc}^{-1}(z) = \sin^{-1}\left(\frac{1}{z}\right).$$

See Also [csc](#) | [acscd](#) | [acsch](#)

Purpose Inverse cosecant in degrees

Syntax $Y = \text{acscd}(X)$

Description $Y = \text{acscd}(X)$ returns the inverse cosecant (cosec^{-1}) of the elements of X in degrees. The function's domain and range include complex values. For real elements of X in the domain $[-\text{Inf},1]$ and $[1,\text{Inf}]$, acscd returns values in the range $[-90,90]$. For values of X outside this range, acscd returns complex values.

Input Arguments **X - Cosecant of angle**
scalar value | vector | matrix | N-D array

Cosecant of angle, specified as a real-valued or complex-valued scalar, vector, matrix, or N-D array. The acscd operation is element-wise when X is non-scalar.

Data Types

single | double

Complex Number Support: Yes

Output Arguments **Y - Angle in degrees**
scalar value | vector | matrix | N-D array

Angle in degrees, returned as a real-valued or complex-valued scalar, vector, matrix, or N-D array of the same size as X .

Examples **Inverse Cosecant of Vector**

```
x = [20 10 Inf];
```

```
y = acscd(x)
```

```
y =
```

```
2.8660    5.7392    0
```

The acscd operation is element-wise when you pass a vector, matrix, or N-D array.

Inverse Cosecant of Complex Value

acscd(1+i)

ans =

25.9136 -30.4033i

See Also

cscd | csc | acsc

acsch

Purpose Inverse hyperbolic cosecant

Syntax $Y = \operatorname{acsch}(X)$

Description $Y = \operatorname{acsch}(X)$ returns the inverse hyperbolic cosecant for each element of X .

The `acsch` function operates element-wise on arrays. The function's domains and ranges include complex values. All angles are in radians.

Examples **Graph of Inverse Hyperbolic Cosecant Function**

Graph the inverse hyperbolic cosecant function over the domains $-20 \leq x \leq -1$ and $1 \leq x \leq 20$.

```
x1 = -20:0.01:-1;  
x2 = 1:0.01:20;  
plot(x1,acsch(x1),x2,acsch(x2)), grid on
```

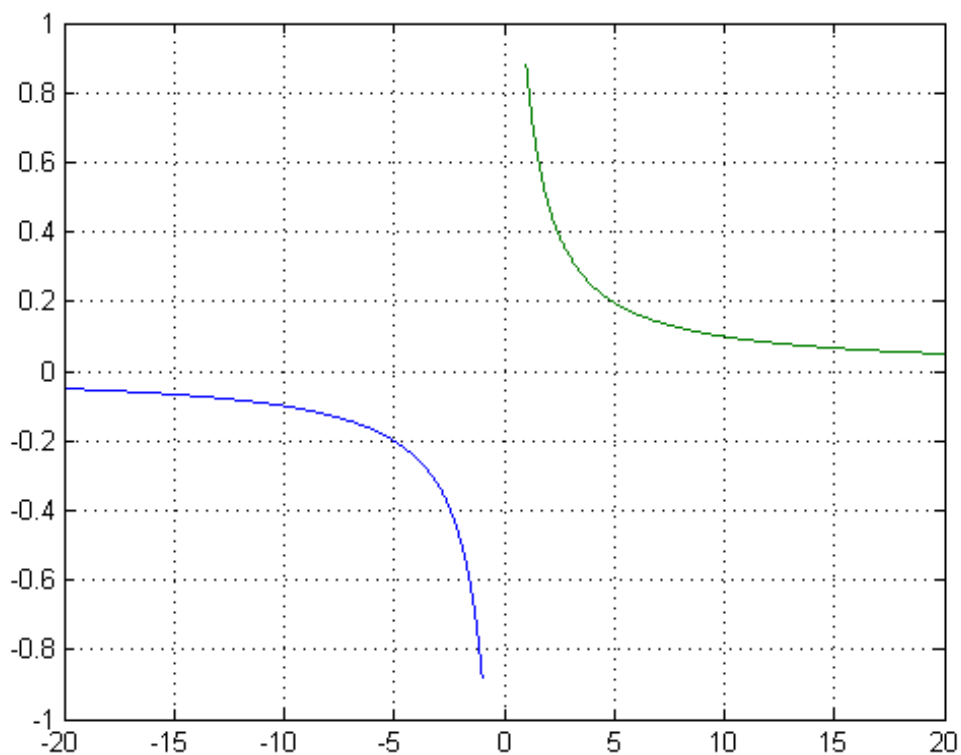
Inverse Hyperbolic Cosecant

The inverse hyperbolic cosecant can be defined as

$$\operatorname{csch}^{-1}(z) = \sinh^{-1}\left(\frac{1}{z}\right).$$

See Also

[acsc](#) | [csch](#) | [asinh](#) | [acosh](#)

actxcontrol

Purpose Create Microsoft ActiveX control in figure window

Syntax

```
h = actxcontrol('progid')
h = actxcontrol('progid','param1',value1,...)
h = actxcontrol('progid',position)
h = actxcontrol('progid', position, fig_handle)
h = actxcontrol('progid',position,fig_handle,event_handler)
h = actxcontrol('progid',position,fig_handle,event_handler,
    'filename')
```

Description `h = actxcontrol('progid')` creates an ActiveX[®] control in a figure window. The programmatic identifier (`progid`) for the control determines the type of control created. (See the documentation provided by the control vendor to get this string.) The returned object, `h`, represents the default interface for the control.

You cannot use an ActiveX server for the `progid` because MATLAB software cannot insert ActiveX servers in a figure. See `actxserver` for use with ActiveX servers.

`h = actxcontrol('progid','param1',value1,...)` creates an ActiveX control using the optional parameter name/value pairs. Parameter names include:

- `position` — MATLAB position vector specifying the position of the control. The format is [left, bottom, width, height] using pixel units.
- `parent` — Handle to parent figure, model, or Command Window.
- `callback` — Name of event handler. To use the same handler for all events, specify a single name. To handle specific events, specify a cell array of event name/event handler pairs.
- `filename` — Sets the initial conditions to the previously saved control.
- `licensekey` — License key to create licensed ActiveX controls that require design-time licenses. See “Deploy ActiveX Controls Requiring Run-Time Licenses” for information on how to use controls that require run-time licenses.

One possible format is:

```
h = actxcontrol('myProgid','newPosition',[0 0 200 200],...
    'myFigHandle',gcf,...
    'myCallback',{ 'Click' 'myClickHandler';...
    'DbtClick' 'myDbtClickHandler';...
    'MouseDown' 'myMouseDownHandler'});
```

The following syntaxes are deprecated and will not become obsolete. They are included for reference, but the previous syntaxes are preferred.

`h = actxcontrol('progid',position)` creates an ActiveX control having the location and size specified in the vector, `position`. The format of this vector is:

```
[x y width height]
```

The first two elements of the vector determine where the control is placed in the figure window, with `x` and `y` being offsets, in pixels, from the bottom left corner of the figure window to the same corner of the control. The last two elements, `width` and `height`, determine the size of the control itself.

The default position vector is `[20 20 60 60]`.

`h = actxcontrol('progid', position, fig_handle)` creates an ActiveX control at the specified position in an existing figure window. The Handle Graphics® handle, `fig_handle`, identifies this window.

The `gcf` command returns the current figure handle.

Note If the figure window designated by `fig_handle` is invisible, the control is invisible. If you want the control you are creating to be invisible, use the handle of an invisible figure window.

`h = actxcontrol('progid',position,fig_handle,event_handler)` creates an ActiveX control that responds to events. Controls respond to events by invoking a MATLAB function whenever an event (such

as clicking a mouse button) is fired. The `event_handler` argument identifies one or more functions to be used in handling events. For more information, see “Specifying Event Handlers” on page 1-122.

`h = actxcontrol('progid', position, fig_handle, event_handler, 'filename')` creates an ActiveX control with the first four arguments, and sets its initial state to that of a previously saved control. MATLAB loads the initial state from the file specified in the string `filename`.

If you do not want to specify an `event_handler`, you can use an empty string (`' '`) as the fourth argument.

The `progid` argument must match the `progid` of the saved control.

Specifying Event Handlers

There is more than one valid format for the `event_handler` argument. Use this argument to specify one of the following:

- A different event handler routine for each event supported by the control
- One common routine to handle selected events
- One common routine to handle all events

In the first case, use a cell array for the `event_handler` argument, with each row of the array specifying an event and handler pair:

```
{'event' 'eventhandler'; 'event2' 'eventhandler2'; ...}
```

`event` is either a string containing the event name or a numeric event identifier (see Example 2), and `eventhandler` is a string identifying the function you want the control to use in handling the event. Include only those events that you want enabled.

In the second case, use the same cell array syntax described, but specify the same `eventhandler` for each event. Again, include only those events that you want enabled.

In the third case, make `event_handler` a string (instead of a cell array) that contains the name of the one function that is to handle all events for the control.

There is no limit to the number of event and handler pairs you can specify in the `event_handler` cell array. However, if you register the same event name to the same callback handler multiple times, MATLAB executes the event only once.

Event handler functions accept a variable number of arguments.

Strings used in the `event_handler` argument are not case-sensitive.

Note Although using a single handler for all events might be easier in some cases, specifying an individual handler for each event creates more efficient code, resulting in better performance.

Tips

If the control implements any custom interfaces, use the `interfaces` function to list them, and the `invoke` function to get a handle to a selected interface.

When you no longer need the control, call `release` to release the interface and free memory and other resources used by the interface. Releasing the interface does not delete the control itself. To release the interface, use the `delete` function.

For more information on handling control events, see [Writing Event Handlers](#).

For an example event handler, see the file `sampev.m` in the `toolbox\matlab\winfun\comcli` folder.

COM functions are available on Microsoft® Windows® systems only.

Note If you encounter problems creating Microsoft Forms 2.0 controls in MATLAB or other non-VBA container applications, see “Use Microsoft Forms 2.0 Controls”.

Examples

Handling Events

The `event_handler` argument specifies how you want the control to handle any events that occur. The control can handle all events with one common handler function, selected events with a common handler function, or each type of event can be handled by a separate function.

This command creates an `mwsamp` control that uses one event handler, `sampev`, to respond to all events:

```
h = actxcontrol('mwsamp.mwsampctrl.2', [0 0 200 200], ...  
    gcf, 'sampev');
```

The next command also uses a common event handler, but will only invoke the handler when selected events, `Click` and `Db1Click` are fired:

```
h = actxcontrol('mwsamp.mwsampctrl.2', [0 0 200 200], ...  
    gcf, {'Click' 'sampev'; 'Db1Click' 'sampev'});
```

This command assigns a different handler routine to each event. For example, `Click` is an event, and `myclick` is the routine that executes whenever a `Click` event is fired:

```
h = actxcontrol('mwsamp.mwsampctrl.2', [0 0 200 200], ...  
    gcf, {'Click', 'myclick'; 'Db1Click' 'my2click'; ...  
    'MouseDown' 'mymoused'});
```

The next command does the same thing, but specifies the events using numeric event identifiers:

```
h = actxcontrol('mwsamp.mwsampctrl.2', [0 0 200 200], ...  
    gcf, {-600, 'myclick'; -601 'my2click'; -605 'mymoused'});
```

For examples of event handler functions and how to register them with MATLAB, see “Sample Event Handlers”.

See Also

`actxserver` | `release` | `delete` (COM) | `save` (COM) | `load` (COM) | `interfaces`

Purpose List currently installed Microsoft ActiveX controls

Syntax `info = actxcontrollist`

Description `info = actxcontrollist` returns a list of controls in `info`, a 1-by-3 cell array containing the name, programmatic identifier (ProgID), and file name for the control. Each control has one row, which MATLAB software sorts by file name.

COM functions are available on Microsoft Windows systems only.

Examples Show information for two controls:

```
list = actxcontrollist;
for k = 1:2
    sprintf(' Name = %s\n ProgID = %s\n File = %s\n', list{k,:})
end
```

MATLAB displays information like:

```
ans =
  Name = Calendar Control 11.0
  ProgID = MSCAL.Calendar.7
  File = C:\Program Files\MSOffice\OFFICE11\MSCAL.OCX
```

```
ans =
  Name = CTreeView Control
  ProgID = CTREEVIEW.CTreeViewCtrl.1
  File = C:\WINNT\system32\dmocx.dll
```

See Also `actxcontrolselect` | `actxcontrol`

actxcontrolselect

Purpose Create Microsoft ActiveX control from GUI

Syntax `h = actxcontrolselect`
`[h, info] = actxcontrolselect`

Description `h = actxcontrolselect` displays a GUI listing all ActiveX controls installed on the system and creates the one you select from the list. Returns handle `h` for the object. Use the handle to identify this control when calling MATLAB COM functions.

`[h, info] = actxcontrolselect` returns a 1-by-3 cell array `info` containing the name, programmatic identifier (ProgID), and file name for the control.

COM functions are available on Microsoft Windows systems only.

See Also `actxcontrollist` | `actxcontrol`

How To

- “Creating Control Objects Using a GUI”

Purpose

Handle to running instance of Automation server

Syntax

```
h = actxGetRunningServer('progid')
```

Description

`h = actxGetRunningServer('progid')` gets a reference to a running instance of the OLE Automation server. `progid` is the programmatic identifier of the Automation server object and `h` is the handle to the default interface of the server object.

The function returns an error if the server specified by `progid` is not currently running or if the server object is not registered. When multiple instances of the Automation server are running, the operating system controls the behavior of this function.

COM functions are available on Microsoft Windows systems only.

Examples

Get a handle to the MATLAB application:

```
h = actxGetRunningServer('matlab.application')
```

See Also

`actxcontrol` | `actxserver`

How To

- “MATLAB COM Automation Server Interface”

Purpose Create COM server

Syntax

```
h = actxserver('progid')
h = actxserver('progid','machine','machineName')
h = actxserver('progid','interface','interfaceName')
h = actxserver('progid','machine','machineName','interface',
    'interfaceName')
h = actxserver('progid',machine)
```

Description `h = actxserver('progid')` creates a local OLE Automation server, where `progid` is the programmatic identifier of an OLE-compliant COM server, and `h` is the handle of the server's default interface.

Get `progid` from the control or server vendor's documentation. To see the `progid` values for MATLAB software, refer to "Programmatic Identifiers".

`h = actxserver('progid','machine','machineName')` creates an OLE Automation server on a remote machine, where `machineName` is a string specifying the name of the machine on which to start the server.

`h = actxserver('progid','interface','interfaceName')` creates a Custom interface server, where `interfaceName` is a string specifying the interface name of the COM object. Values for `interfaceName` are

- `IUnknown` — Use the `IUnknown` interface.
- The Custom interface name

You must know the name of the interface and have the server vendor's documentation in order to use the `interfaceName` value. For information about custom COM servers and interfaces, see "COM Server Types".

Note The MATLAB COM Interface does not support invoking functions with optional parameters.

```
h =  
actxserver('progid','machine','machineName','interface',  
'interfaceName') creates a Custom interface server on a  
remote machine.
```

The following syntaxes are deprecated and will not become obsolete. They are included for reference, but the syntaxes described earlier are preferred:

```
h = actxserver('progid',machine) creates a COM server running  
on the remote system named by the machine argument. This can be an  
IP address or a DNS name. Use this syntax only in environments that  
support Distributed Component Object Model (for more information,  
see “Using MATLAB Application as DCOM Server”).
```

Tips

For components implemented in a dynamic link library (DLL), `actxserver` creates an in-process server. For components implemented as an executable (EXE), `actxserver` creates an out-of-process server. Out-of-process servers can be created either on the client system or on any other system on a network that supports DCOM.

If the control implements any Custom interfaces, use the `interfaces` function to list them, and the `invoke` function to get a handle to a selected interface.

You can register events for COM servers.

COM functions are available on Microsoft Windows systems only.

Examples

Microsoft Excel® Workbook Example

This example creates an OLE Automation server, Excel version 9.0, and manipulates a workbook in the application.

Create a COM server running Microsoft Excel.

```
e = actxserver ('Excel.Application')
```

```
e =  
    COM.Excel.application
```

Make the Excel frame window visible.

```
e.Visible = 1;
```

Use the `get` method on the Excel object `e` to list all properties of the application.

```
e.get
```

```
Application: [1x1
Interface.Microsoft_Excel_9.0_Object_Library._Application]
  Creator: 'xlCreatorCode'
  .
  .
  .
  Workbooks: [1x1
Interface.Microsoft_Excel_9.0_Object_Library.Workbooks]
  .
  .
  .
  Caption: 'Microsoft Excel - Book1'
  CellDragAndDrop: 0
  ClipboardFormats: {3x1 cell}
  .
  .
  .
  Cursor: 'xlNorthwestArrow'
  .
  .
  .
```

Create an interface `eWorkBooks`.

```
eWorkbooks = e.Workbooks
```

```
eWorkbooks =
  Interface.Microsoft_Excel_9.0_Object_Library.Workbooks
```

List all methods for that interface.

```
eWorkbooks.invoke
```

```

    Add: 'handle Add(handle, [Optional]Variant)'
    Close: 'void Close(handle)'
    Item: 'handle Item(handle, Variant)'
    Open: 'handle Open(handle, string, [Optional]Variant)'
    OpenText: 'void OpenText(handle, string, [Optional]Variant)'
    .
    .
    .

```

Add a new workbook w, also creating a new interface.

```
w = eWorkbooks.Add
```

```

w =
    Interface.Microsoft_Excel_9.0_Object_Library._Workbook

```

Close Excel and delete the object.

```

e.Quit;
e.delete;

```

See Also

actxcontrol | actxGetRunningServer | release | delete (COM) | save (COM) | load (COM) | interfaces | invoke

Related Examples

- “Read Excel Spreadsheet Data”
- “Use MATLAB Application as Automation Client”

matlab.apputil.create

Purpose Create or modify app project file for packaging app into .mlappinstall file using interactive dialog box

Syntax matlab.apputil.create
matlab.apputil.create(prjfile)

Description matlab.apputil.create opens the Package App dialog box that steps you through the process of creating an .mlappinstall file.

matlab.apputil.create(prjfile) loads the specified .prj file and populates the Package App dialog box with the information from the specified project file. Use this option if you need to update an existing app.

Input Arguments **prjfile - Full or partial path to the .prj file**
string

Full or partial path to the .prj file you created previously with the Package App dialog box, specified as a string

Example: 'C:\myapp.prj'

Examples **Open Dialog Box for Creating an App Package**

matlab.apputil.create

Package App
H:\Untitled1.prj

Pick main file | **Describe your app**

Main file
Add main function file (program's entry point).
[Add main file](#)

Files included through analysis
These are the files found through dependency analysis.
[Refresh](#)

Shared resources and helper files
Place images, data files, and GUIs (.fig files) here if referenced by any functions.
Also place here:

- Functions called using `eval` (and its variants)
- Functions not on the MATLAB path
- Private functions

[Add files/folders](#)

Describe your app

Version

matlab.apputil.create

Minimally, add a main file and specify an app name. MATLAB creates and continuously saves a .prj file, regardless of whether you click **Package**. However, MATLAB does not create a .mlappinstall file if you do not click **Package**.

Update Existing App Package

Assume you have an existing project file, myapp.prj. You want to add a file and update the description.

Open the Package App dialog box, specifying the previously created .prj file:

```
matlab.apputil.create('myapp.prj')
```

The dialog box opens populated with the data you previously specified for myapp. Adjust the information in the dialog box, as needed.

See Also

matlab.apputil.package

Concepts

- “MATLAB App Installer File — mlappinstall”

Purpose

List installed app information

Syntax

```
matlab.apputil.getInstalledAppInfo
```

```
appinfo = matlab.apputil.getInstalledAppInfo
```

Description

`matlab.apputil.getInstalledAppInfo` displays the ID and name of all installed custom apps. It does not display this information for apps packaged with MathWorks® products.

`appinfo = matlab.apputil.getInstalledAppInfo` returns structure to `appinfo`, which includes the status, ID, location, and name of all installed custom apps. It does not return this information for apps packaged with MathWorks products.

Output Arguments

appinfo - Information about installed apps

structure array

Information about the installed app, returned as a structure array, with one element for each installed app. Each element of the structure array has the following fields:

status - Installation status

'installed'

Status of the installation, returned as the string 'installed'.

id - Unique identifier for the installed app

string

Unique identifier for the installed app, returned as a string

The ID is for use when running or uninstalling the app programmatically.

location - Folder where the app is installed

string

matlab.apputil.getInstalledAppInfo

Folder where the app is installed, returned as a string

name - Name of the installed app

string

Name of the installed app as it appears in the apps gallery, returned as a string

Examples

Display Installed Apps Information in the Command Window

Assume you installed two apps, LinePlotter and PlotRandNumbers. Display the app information in the Command Window.

```
matlab.apputil.getInstalledAppInfo
```

```
ID                               Name
-----
LinePlotterAPP                  LinePlotter
PlotRandNumbersAPP             PlotRandNumbers
```

Store Installed App Information in a Variable

Assume you installed an app, ColorPalette. Get the app information and store it in a variable, myappinfo.

```
myappinfo = matlab.apputil.getInstalledAppInfo;
```

Store Installed App Information in a Variable and Display IDs

Assume you installed two apps, LinePlotter and PlotRandNumbers. Get and store the app information for both installed apps in a variable, myappinfo. Then, get the id for each app.

```
myappinfo = matlab.apputil.getInstalledAppInfo
```

```
myappinfo =
```

```
1x2 struct array with fields:
    id
```

```
name  
status  
location
```

Get the id of each installed app:

```
appids={myappinfo.id}
```

```
appids =
```

```
    'LinePlotterAPP'    'PlotRandNumbersAPP'
```

See Also

[matlab.apputil.install](#) | [matlab.apputil.uninstall](#) |
[matlab.apputil.run](#)

Concepts

- “MATLAB App Installer File — mlappinstall”

matlab.apputil.install

Purpose	Install app from a <code>.mlappinstall</code> file
Syntax	<code>appinfo = matlab.apputil.install(appfile)</code>
Description	<code>appinfo = matlab.apputil.install(appfile)</code> installs the specified app file and returns information about the app.
Input Arguments	<p>appfile - Full or partial path to <code>.mlappinstall</code> file string</p> <p>Full or partial path of the app file you want to install, specified as a string.</p> <p>Example: <code>'C:\myguis\myapps\myapp.mlappinstall'</code></p>
Output Arguments	<p>appinfo - Information about installed app structure</p> <p>Information about the installed app, returned as a structure with the fields:</p> <p>status - Installation status <code>'installed' 'updated'</code></p> <p>Installation status, returned as a string:</p> <ul style="list-style-type: none">• <code>'installed'</code> — New app is installed.• <code>'updated'</code> — Previously installed app is updated. <p>id - Unique identifier string</p> <p>Unique identifier for the installed app, returned as a string</p> <p>The ID is for use when running or uninstalling the app programmatically.</p> <p>location - Folder where app is installed string</p>

Folder where app is installed, returned as a string

name - Name of installed app

string

Name of installed app as it appears in the apps gallery, returned as a string

Examples

Install App and Display Information About the Installation

Assume you have downloaded an app from File Exchange named EmployeeData. Install it and return information about the installation to the variable `appinfo`. Later, if you decide to uninstall the app programmatically, you have the app id required to do so.

```
appinfo = matlab.apputil.install...  
    ('C:\myguis\myapps\EmployeeData.mlappinstall')  
  
appinfo =  
  
        id: 'EmployeeDataApp'  
       name: 'EmployeeData'  
      status: 'installed'  
 location: 'C:\myguis\myapps\EmployeeData.mlappinstall'
```

See Also

`matlab.apputil.uninstall` | `matlab.apputil.getInstalledAppInfo`
| `matlab.apputil.package`

Concepts

- “MATLAB App Installer File — `mlappinstall`”

matlab.apputil.package

Purpose	Package app files into .mlappinstall file
Syntax	<code>matlab.apputil.package(prjfile)</code>
Description	<code>matlab.apputil.package(prjfile)</code> creates a .mlappinstall file based on the information in the specified <code>prjfile</code> .
Input Arguments	prjfile - Full or partial path to app project (.prj) file string Full or partial path to app project (.prj) file, specified as a string. Example: 'plotdata.prj'
Examples	Create mlappinstall File for Previously Created Project File Assume you previously created <code>myprjfile.prj</code> using <code>matlab.apputil.create</code> . The following command creates the corresponding .mlappinstall file. <code>matlab.apputil.package('myprjfile.prj')</code>
Tips	<ul style="list-style-type: none">• To create a .prj file, use <code>matlab.apputil.create</code>.
See Also	<code>matlab.apputil.create</code> <code>matlab.apputil.install</code> <code>matlab.apputil.run</code>

Purpose Run app programmatically

Syntax `matlab.apputil.run(appid)`

Description `matlab.apputil.run(appid)` runs the custom app specified by the unique identifier, `appid`.

Input Arguments **appid - ID of custom app**
string

ID of custom app you want to run, specified as a string.

Example: `'DataExplorationAPP'`

- Tips**
- The ID of a custom app is returned when you install it. You can use `matlab.apputil.getInstalledAppInfo` to get the ID after you have installed an app.
 - When a custom app runs, MATLAB adds any folders it needs to have added to the path, as identified when the app was packaged. When the app exits, MATLAB removes those folders from the path.
 - You can run multiple, different custom apps concurrently. However, you cannot run two instances of the same app concurrently.

Examples **Run Previously Installed App**

Assume you installed two apps, `PlotData` and `setslider`. Run `PlotData` programmatically, using its ID.

Get IDs of all installed apps.

```
matlab.apputil.getInstalledAppInfo
```

ID	Name
-----	-----
setsliderAPP	setslider
PlotDataAPP	PlotData

matlab.apputil.run

Run PlotData.

```
matlab.apputil.run('PlotDataAPP')
```

See Also

[matlab.apputil.create](#) | [matlab.apputil.install](#) |
[matlab.apputil.getInstalledAppInfo](#)

Purpose Uninstall app

Syntax `matlab.apputil.uninstall(appid)`

Description `matlab.apputil.uninstall(appid)` removes the app specified by the unique identifier, `appid`. MATLAB removes all files corresponding to the app and removes the app from the app gallery.

Input Arguments **appid - ID of app**
string

ID of app to be uninstalled, specified as a string.

Example: 'DataExplorationAPP'

Tips

- To determine the `appid` of an installed app, preserve the value returned when you install the app programmatically with `matlab.apputil.install`, or use `matlab.apputil.getInstalledAppInfo`.

Examples **Uninstall App**

Assume you previously installed two apps, `setslider` and `simplegui`. Get the IDs of all installed apps, and then use the ID for `simplegui` to uninstall it.

View the IDs of all apps

```
matlab.apputil.getInstalledAppInfo
```

ID	Name
setsliderAPP	setslider
simpleguiAPP	simplegui

Uninstall the `simplegui` app.

```
matlab.apputil.uninstall('simpleguiAPP')
```

matlab.apputil.uninstall

Confirm the app was removed, by running
`matlab.apputil.getInstalledAppInfo` again.

```
matlab.apputil.getInstalledAppInfo
```

ID	Name
-----	-----
setsliderAPP	setslider

See Also

`matlab.apputil.install` | `matlab.apputil.getInstalledAppInfo`

Purpose

Record additional causes of exception

Syntax

```
baseExcep = addCause(baseExcep, causeExcep)
```

Description

baseExcep = addCause(*baseExcep*, *causeExcep*) adds information to existing exception *baseExcep* to help determine its cause. The added information is in the form of a second exception *causeExcep*. Both *baseExcep* and *causeExcep* are objects of the MException class. The *baseExcep* and *causeExcep* inputs are scalar objects of the mException class.

The exception has a property called *cause* in which you can store a series of additional exceptions, each saving information on what caused the initial error. (See the figure in the documentation for “The MException Class”.) When your program calls addCause, MATLAB appends a new exception *cause* to this field in the base exception *exception*. When your error handling code catches the error in a try/catch statement, execution of the catch part of this statement makes the base exception, along with all of the appended cause records, available to help diagnose the error.

Examples

This example attempts to open a file in a folder that is not on the MATLAB path. It uses a nested try-catch block to give the user the opportunity to extend the path. If the file still cannot be found, the program issues an exception with the first error appended to the second using addCause:

```
function data = read_it(filename);
try
    % Attempt to open and read from a file.
    fid = fopen(filename, 'r');
    data = fread(fid);
catch exception1
    % If the error was caused by an invalid file ID, try
    % reading from another location.
    if strcmp(exception1.identifier, 'MATLAB:FileIO:InvalidFid')
        msg = sprintf( ...
```

addCause (MException)

```
        '\nCannot open file %s. Try another location? ', ...
        filename);
    reply = input(msg, 's')
    if reply(1) == 'y'
        newFolder = input('Enter folder name: ', 's');
    else
        throw(exception1);
    end
    oldpath = addpath(newFolder);
    try
        fid = fopen(filename, 'r');
        data = fread(fid);
    catch exception2
        exception3 = addCause(exception2, exception1)
        path(oldpath);
        throw(exception3);
    end
    path(oldpath);
end
end
fclose(fid);

try
    d = read_it('anytextfile.txt');
catch exception
end

exception
exception =
    MException object with properties:

    identifier: 'MATLAB:FileIO:InvalidFid'
    message: 'Invalid file identifier. Use fopen
             to generate a valid file identifier.'
    stack: [1x1 struct]
    cause: {[1x1 MException]}
```

```
Cannot open file anytextfile.txt. Try another location?y
Enter folder name: xxxxxxx
Warning: Name is nonexistent or not a directory: xxxxxxx.
> In path at 110
  In addpath at 89
```

See Also

```
last(MException) | throwAsCaller(MException)
| rethrow(MException) | throw(MException) |
getReport(MException) | MException | assert | error |
try, catch
```

addevent

Purpose Add event to `timeseries` object

Syntax
`ts = addevent(ts,e)`
`ts = addevent(ts,Name,Time)`

Description `ts = addevent(ts,e)` adds one or more `tsdata.event` objects, `e`, to the `timeseries` object `ts`. `e` is either a single `tsdata.event` object or an array of `tsdata.event` objects.

`ts = addevent(ts,Name,Time)` constructs one or more `tsdata.event` objects and adds them to the `Events` property of `ts`. `Name` is a cell array of event name strings. `Time` is a cell array of event times.

Examples Create a time-series object and add an event to this object.

```
%% Import the sample data
load count.dat

%% Create time-series object
count1=timeseries(count(:,1),1:24,'name','data');

%% Modify the time units to be 'hours' ('seconds' is default)
count1.TimeInfo.Units = 'hours';

%% Construct and add the first event at 8 AM
e1 = tsdata.event('AMCommute',8);

%% Specify the time units of the time
e1.Units = 'hours';

View the properties (EventData, Name, Time, Units, and StartDate)
of the event object.

get(e1)

MATLAB software responds with

    EventData: []
```

```
        Name: 'AMCommute'  
        Time: 8  
        Units: 'hours'  
        StartDate: ''  
%% Add the event to count1  
count1 = addevent(count1,e1);
```

An alternative syntax for adding two events to the time series count1 is as follows:

```
count1 = addevent(count1,{'AMCommute' 'PMCommute'},{8 18})
```

See Also

[timeseries](#) | [tsdata.event](#)

audioinfo

Purpose Information about audio file

Syntax `info = audioinfo(filename)`

Description `info = audioinfo(filename)` returns information about the contents of the audio file specified by `filename`.

Input Arguments **filename - Name of file**
string

Name of file, specified as a string. If a path is specified, it can be absolute, relative, or partial.

Example: `'myFile.mp3'`

Example: `'../myFile.mp3'`

Example: `'C:\temp\myFile.mp3'`

`audioinfo` supports the following file formats.

Platform Support	File Format
All platforms	WAVE (.wav)
	OGG (.ogg)
	FLAC (.flac)
	AU (.au)
Windows 7 (or later), Macintosh, and Linux®	MP3 (.mp3)
	MPEG-4 AAC (.m4a, .mp4)

On Windows 7 platforms (or later), `audioinfo` might also return information about the contents of any files supported by Windows Media® Foundation.

On Linux platforms, `audioinfo` might also return information about the contents of any files supported by GStreamer.

audioinfo can extract audio metadata from MPEG-4 (.mp4, .m4v) video files on Windows 7 or later, Mac OS X 10.7 Lion or higher, and Linux, and from Windows Media Video (.wmv) and AVI (.avi) files on Windows 7 (or later) and Linux platforms.

Output Arguments

info - Information about audio file

structure

Information about audio file, returned as a structure. info can contain the following fields.

Field Name	Description	Data Type
Filename	Filename including the absolute path to the file and the file extension.	string
CompressionMethod	Compression method used.	string
NumChannels	Number of audio channels encoded in	double
SampleRate	Sample rate of the audio data in the file, in hertz.	double
TotalSamples	Total number of audio samples in the file.	double
Duration	Duration of the file, in seconds.	double
BitsPerSample	Number of bits per sample encoded in the audio file. Only valid for WAVE (.wav) and FLAC (.flac) files.	double

Field Name	Description	Data Type
BitRate	Number of kilobits per second (kbit/s) used for compressed audio files. Only valid for MP3 (.mp3) and MPEG-4 Audio (.m4a, .mp4) files.	double
Title	Value of 'Title', if any.	string
Artist	Value of 'Artist', if any.	string
Comment	Value of 'Comment', if any.	string

Note The BitRate property returns the actual bit rate on Mac platforms, and not the encoded bit rate. This means that bit rate values might be lower than specified at the time of the encoding, depending on the source data.

Note On Mac platforms, audioinfo returns metadata from .m4a and .mp4 files only on Mac OS X 10.7 Lion or higher. Previous versions of Mac OS X will not read the 'Title', 'Author', or 'Comment' fields.

Examples

Get Information About Audio File

Create a WAVE file from the example file handel.mat, and get information about the file.

Create a WAVE (.wav) file in the current folder.

```
load handel.mat
filename = 'handel.wav';
audiowrite(filename,y,Fs);
clear y Fs
```

Use `audioinfo` to return information about the WAVE file.

```
info = audioinfo(filename)

info =
    Filename: 'S:\handel.wav'
    CompressionMethod: 'Uncompressed'
    NumChannels: 1
    SampleRate: 8192
    TotalSamples: 73113
    Duration: 8.9249
    Title: []
    Comment: []
    Artist: []
    BitsPerSample: 16
```

Limitations

- For MP3 and MPEG-4 AAC audio files on Windows 7 or later and Linux platforms, `audioinfo` might report fewer samples than expected. On Linux platforms, this is due to a limitation in the underlying GStreamer framework.
- On Linux platforms, `audioinfo` interprets single channel data in MPEG-4 AAC files as stereo data.

See Also

`audioread` | `audiowrite`

audioread

Purpose Read audio file

Syntax

```
[y,Fs] = audioread(filename)
[y,Fs] = audioread(filename,samples)

[y,Fs] = audioread( ___,dataType)
```

Description [y,Fs] = audioread(filename) reads data from the file named filename, and returns sampled data,y, and a sample rate for that data, Fs.

[y,Fs] = audioread(filename,samples) reads the selected range of audio samples in the file, where samples is a vector of the form [start,finish].

[y,Fs] = audioread(___,dataType) returns sampled data in the data range corresponding to the dataType of 'native' or 'double', and can include any of the input arguments in previous syntaxes.

Input Arguments

filename - Name of file to read

string

Name of file to read, specified as a string that includes the file extension. If a path is specified, it can be absolute, relative or partial.

Example: 'myFile.mp3'

Example: '../myFile.mp3'

Example: 'C:\temp\myFile.mp3'

audioread supports the following file formats.

Platform Support	File Format
All platforms	WAVE (.wav)
	OGG (.ogg)
	FLAC (.flac)
	AU (.au)
Windows 7 (or later), Macintosh, and Linux	MP3 (.mp3)
	MPEG-4 AAC (.m4a, .mp4)

On Windows platforms prior to Windows 7, audioread does not read WAVE files with MP3 encoded data.

On Windows 7 (or later) platforms, audioread might also read any files supported by Windows Media Foundation.

On Linux platforms, audioread might also read any files supported by GStreamer.

audioread can extract audio from MPEG-4 (.mp4, .m4v) video files on Windows 7 or later, Macintosh, and Linux, and from Windows Media Video (.wmv) and AVI (.avi) files on Windows 7 (or later) and Linux platforms.

samples - Audio samples to read

[1, inf] (default) | two-element vector of positive scalar integers

Audio samples to read, specified as a two-element vector of the form [start, finish], where start and finish are the first and last samples to read, and are positive scalar integers.

- start must be less than or equal to finish.
- start and finish must be less than the number of audio samples in the file,
- You can use inf to indicate the last sample in the file.

Note When reading a portion of some MP3 files on Windows 7 platforms, `audioread` might read a shifted range of samples. This is due to a limitation in the underlying Windows Media Foundation framework.

When reading a portion of MP3 and M4A files on Linux platforms, `audioread` might read a shifted range of samples. This is due to a limitation in the underlying GStreamer framework.

Example: `[1,100]`

Data Types

`double`

dataType - Data format of audio data, *y*

`'double'` (default) | `'native'`

Data format of audio data,*y*, specified as one of the following strings:

- `'double'` Double-precision normalized samples.
- `'native'` Samples in the native format found in the file.

For compressed audio formats, such as MP3 and MPEG-4 AAC that do not store data in integer form, `'native'` defaults to `'single'`.

Output Arguments

y - Audio data

`matrix`

Audio data in the file, returned as an *m*-by-*n* matrix, where *m* is the number of audio samples read and *n* is the number of audio channels in the file.

- If you do not specify `dataType`, or `dataType` is `'double'`, then *y* is of type `double`, and matrix elements are normalized values between `-1.0` and `1.0`.

- If `dataType` is 'native', then `y` can be one of several MATLAB data types, depending on the file format and the `BitsPerSample` value of the input file. Call `audioinfo` to determine the `BitsPerSample` value of the file.

File Format	BitsPerSample	Data Type of <code>y</code>	Data Range of <code>y</code>
WAVE (.wav)	8	uint8	$0 \leq y \leq 255$
	16	int16	$-32768 \leq y \leq +32767$
	24	int32	$-2^{32} \leq y \leq 2^{32}-1$
	32	int32	$-2^{32} \leq y \leq 2^{32}-1$
	32	single	$-1.0 \leq y \leq +1.0$
	64	double	$-1.0 \leq y \leq +1.0$
FLAC (.flac)	8	uint8	$0 \leq y \leq 255$
	16	int16	$-32768 \leq y \leq +32767$
	24	int32	$-2^{32} \leq y \leq 2^{32}-1$
MP3 (.mp3), MPEG-4 AAC (.m4a, .mp4), OGG (.ogg), and certain compressed WAVE files	N/A	single	$-1.0 \leq y \leq +1.0$

Note Where `y` is `single` or `double` and the `BitsPerSample` is 32 or 64, values in `y` might exceed `-1.0` or `+1.0`.

Fs - Sample rate

positive scalar

Sample rate, in hertz, of audio data `y`, returned as a positive scalar.

Examples

Read Complete Audio File

Create a WAVE file from the example file `handel.mat`, and read the file back into MATLAB.

Create a WAVE (`.wav`) file in the current folder.

```
load handel.mat
```

```
filename = 'handel.wav';  
audiowrite(filename,y,Fs);  
clear y Fs
```

Read the data back into MATLAB using `audioread`.

```
[y,Fs] = audioread('handel.wav');
```

Play the audio.

```
sound(y,Fs);
```

Read Portion of Audio File

Create a FLAC file from the example file `handel.mat`, and then read only the first 2 seconds.

Create a FLAC (`.flac`) file in the current folder.

```
load handel.mat
```



```
filename = 'handel.flac';  
audiowrite(filename,y,Fs);
```

Read only the first 2 seconds.

```
samples = [1,2*Fs];  
clear y Fs  
[y,Fs] = audioread(filename,samples);
```

Play the samples.

```
sound(y,Fs);
```

Return Audio in Native Integer Format

Create a FLAC file and read the first 2 seconds according to the previous Example. Then, view the data type of the sampled data `y`.

```
whos y
```

Name	Size	Bytes	Class	Attributes
y	16384x1	131072	double	

The data type of `y` is `double`.

Request audio data in the native format of the file, and then view the data type of the sampled data `y`.

```
[y,Fs] = audioread(filename,'native');  
whos y
```

Name	Size	Bytes	Class	Attributes
y	16384x1	32768	int16	

The data type of `y` is now `int16`.

audioread

Limitations

- For MP3 and MPEG-4 AAC audio files on Windows 7 or later and Linux platforms, `audioread` might read fewer samples than expected. On Windows 7 platforms, this is due to a limitation in the underlying Media Foundation framework. On Linux platforms, this is due to a limitation in the underlying GStreamer framework. If you require sample-accurate reading, work with WAV or FLAC files.
- On Linux platforms, `audioread` reads MPEG-4 AAC files that contain single-channel data as stereo data.

See Also

`audiowrite` | `audioinfo`

Purpose

Write audio file

Syntax

```
audiowrite(filename,y,Fs)
audiowrite(filename,y,Fs,Name,Value)
```

Description

`audiowrite(filename,y,Fs)` writes a matrix of audio data, `y`, with sample rate `Fs` to a file called `filename`. The `filename` input also specifies the output file format. The output data type depends on the output file format and the data type of the audio data, `y`.

`audiowrite(filename,y,Fs,Name,Value)` uses additional options specified by one or more `Name,Value` pair arguments.

Input Arguments**filename - Name of file to write**

string

Name of file to write, or the full path to the file, specified as a string that includes the file extension. If a path is specified, it can be absolute or relative. If you do not specify the path, then the destination directory is the current working directory.

`audiowrite` supports the following file formats.

Platform Support	File Format
All platforms	WAVE (.wav)
	OGG (.ogg)
	FLAC (.flac)
Windows and Mac	MPEG-4 AAC (.m4a, .mp4)

Example: 'myFile.m4a'

Example: '../myFile.m4a'

Example: 'C:\temp\myFile.m4a'

When writing AAC files on Windows, `audiowrite` pads the front and back of the output signal with extra samples of silence. The Windows

AAC encoder also places a very sharp fade-in and fade-out on the audio. This results in audio with an increased number of samples after being written to disk.

y - Audio data to write

matrix

Audio data to write, specified as an m -by- n matrix, where m is the number of audio samples to write and n is the number of audio channels to write.

If either m or n is 1, then `audiowrite` assumes that this dimension specifies the number of audio channels, and the other dimension specifies the number of audio samples.

The maximum number of channels depends on the file format.

File Format	Maximum Number of Channels
WAVE (.wav)	256
OGG (.ogg)	255
FLAC (.flac)	8
MPEG-4 AAC (.m4a, .mp4)	2

The valid range for the data in y depends on the data type of y .

Data Type of y	Valid Range for y
uint8	$0 \leq y \leq 255$
int16	$-32768 \leq y \leq +32767$
int32	$-2^{32} \leq y \leq 2^{32}-1$
single	$-1.0 \leq y \leq +1.0$
double	$-1.0 \leq y \leq +1.0$

Data beyond the valid range is clipped.

If `y` is `single` or `double`, then audio data in `y` should be normalized to values in the range -1.0 and 1.0 , inclusive.

Data Types

`single` | `double` | `int16` | `int32` | `uint8`

F_s - Sample rate

positive scalar

Sample rate, in hertz, of audio data `y`, specified as a positive scalar greater than 0. Values of `Fs` are truncated to integer boundaries. When writing to `.m4a` or `.mp4` files on Windows platforms, `audiowrite` supports only samples rates of 44100 and 48000.

Example: 44100

Data Types

`double`

Name-Value Pair Arguments

Specify optional comma-separated pairs of `Name`, `Value` arguments. `Name` is the argument name and `Value` is the corresponding value. `Name` must appear inside single quotes (`' '`). You can specify several name and value pair arguments in any order as `Name1,Value1,...,NameN,ValueN`.

Example: `'Title','Symphony No. 9','Artist','My Orchestra'` instructs `audiowrite` to write an audio file with the title “Symphony No. 9” and the artist information “My Orchestra.”

'BitsPerSample' - Number of output bits per sample

16 (default) | 8 | 24 | 32 | 64

Number of output bits per sample, specified as the comma-separated pair consisting of `'BitsPerSample'` and a number.

Only available for WAVE (`.wav`) and FLAC (`.flac`) files. For FLAC files, only 8, 16, or 24 bits per sample are supported.

Example: `'BitsPerSample',32`

'BitRate' - Kilobits per second (kbit/s)

128 (default) | 64 | 96 | 160 | 192 | 256 | 320

Number of kilobits per second (kbit/s) used for compressed audio files, specified as the comma-separated pair consisting of 'BitRate' and an integer. Noninteger values are truncated. On Windows 7 or later, the only valid values are 96, 128, 160, and 192.

In general, a larger BitRate value results in higher compression quality.

Only available for MPEG-4 (.m4a, .mp4) files.

Example: 'BitRate',96

'Quality' - Quality setting for the Ogg Vorbis Compressor

75 (default) | value in the range [0 100]

Quality setting for the Ogg Vorbis Compressor, specified as the comma-separated pair consisting of 'Quality' and a number in the range [0 100], where 0 is lower quality and higher compression, and 100 is higher quality and lower compression.

Only available for OGG (.ogg) files.

Example: 'Quality',25

'Title' - Title information

[] (default) | string

Title information, specified as the comma-separated pair consisting of 'Title' and a string.

'Artist' - Artist information

[] (default) | string

Artist information, specified as the comma-separated pair consisting of 'Artist' and a string.

'Comment' - Additional information

[] (default) | string

Additional information, specified as the comma-separated pair consisting of 'Comment' and a string.

Note On Mac platforms, `audiowrite` writes metadata to WAVE, OGG, and FLAC files only, and will not write the 'Title', 'Author', or 'Comment' fields to MPEG-4 AAC files.

Examples

Write an Audio File

Create a WAVE file from the example file `handel.mat`, and read the file back into MATLAB.

Write a WAVE (.wav) file in the current folder.

```
load handel.mat

filename = 'handel.wav';
audiowrite(filename,y,Fs);
clear y Fs
```

Read the data back into MATLAB using `audioread`.

```
[y,Fs] = audioread(filename);
```

Listen to the audio.

```
sound(y,Fs);
```

Specify Bits Per Sample and Metadata

Create a FLAC file from the example file `handel.mat` and specify the number of output bits per sample and a comment.

```
load handel.mat

filename = 'handel.flac';
```

audiowrite

```
audiowrite(filename,y,Fs,'BitsPerSample',24,...  
'Comment','This is my new audio file.');
```

```
clear y Fs
```

View information about the new FLAC file.

```
info = audioinfo(filename)
```

```
info =
```

```
      Filename: 'S:\handel.flac'  
CompressionMethod: 'FLAC'  
      NumChannels: 1  
      SampleRate: 8192  
TotalSamples: 73113  
      Duration: 8.9249  
      Title: []  
      Comment: 'This is my new audio file.'  
      Artist: []  
BitsPerSample: 24
```

Algorithms

The output data type is determined by the file format, the data type of `y`, and the specified output `BitsPerSample`.

File Formats	Data Type of <code>y</code>	Output <code>BitsPerSample</code>	Output Data Type
WAVE (.wav),	uint8, int16, int32, single, double	8	uint8
		16	int16
		24	int32
	uint8, int16, int32	32	int32
	single, double	32	single
	single, double	64	double

File Formats	Data Type of y	Output BitsPerSample	Output Data Type
FLAC (.flac)	uint8, int16, int32, single, double	8	int8
		16	int16
		24	int32
MPEG-4 (.m4a, .mp4), OGG (.ogg)	uint8, int16, int32, single, double	N/A	single

See Also

audioinfo | audioread

addframe (avifile)

Purpose Add frame to Audio/Video Interleaved (AVI) file

Syntax

```
aviobj = addframe(aviobj,frame)
aviobj = addframe(aviobj,frame1,frame2,frame3,...)
aviobj = addframe(aviobj,mov)
aviobj = addframe(aviobj,h)
```

Description `aviobj = addframe(aviobj,frame)` appends the data in `frame` to the AVI file identified by `aviobj`, which was created by a previous call to `avifile`. `frame` can be either an indexed image (m-by-n) or a truecolor image (m-by-n-by-3) of double or uint8 precision. If `frame` is not the first frame added to the AVI file, it must be consistent with the dimensions of the previous frames.

`addframe` returns a handle to the updated AVI file object, `aviobj`. For example, `addframe` updates the `TotalFrames` property of the AVI file object each time it adds a frame to the AVI file.

`aviobj = addframe(aviobj,frame1,frame2,frame3,...)` adds multiple frames to an AVI file.

`aviobj = addframe(aviobj,mov)` appends the frames contained in the MATLAB movie `mov` to the AVI file `aviobj`. MATLAB movies that store frames as indexed images use the colormap in the first frame as the colormap for the AVI file, unless the colormap has been previously set.

`aviobj = addframe(aviobj,h)` captures a frame from the figure or axis handle `h` and appends this frame to the AVI file. `addframe` renders the figure into an offscreen array before appending it to the AVI file. This ensures that the figure is written correctly to the AVI file even if the figure is obscured on the screen by another window or screen saver.

Tips

- `avifile` cannot write files larger than 2 GB. Use `VideoWriter` and `writeVideo` to create larger files.
- If you are creating an animation from a figure with an `EraseMode` property set to `'xor'`, you must use `getframe` to capture the graphics into a frame of a MATLAB movie. Add the frame to the AVI file using

the syntax `aviobj = addframe(aviobj, mov)`. See the example for an illustration.

Examples

This example calls `addframe` to add frames to the AVI file object `aviobj`.

```
aviobj = avifile('example.avi','compression','None');

t = linspace(0,2.5*pi,40);
fact = 10*sin(t);
fig=figure;
[x,y,z] = peaks;
for k=1:length(fact)
    h = surf(x,y,fact(k)*z);
    axis([-3 3 -3 3 -80 80])
    axis off
    caxis([-90 90])

    F = getframe(fig);
    aviobj = addframe(aviobj,F);
end
close(fig);
aviobj = close(aviobj);
```

See Also

[VideoWriter](#) | [avifile](#) | [close \(avifile\)](#) | [movie2avi](#)

addlistener (handle)

Purpose

Create event listener

Syntax

```
lh = addlistener(Hsource, 'EventName', callback)
lh = addlistener(Hsource, property, 'EventName', callback)
```

Description

`lh = addlistener(Hsource, 'EventName', callback)` creates a listener for the specified event.

`lh = addlistener(Hsource, property, 'EventName', callback)` creates a listener for one of the predefined property events. There are four property events:

- **PreSet** — triggered just before the property value is set, before calling its set access method.
- **PostSet** — triggered just after the property value is set.
- **PreGet** — triggered just before a property value query is serviced, before calling its get access method.
- **PostGet** — triggered just after returning the property value to the query

See “Events and Listeners — Syntax and Techniques” for more information.

Input Arguments

Hsource

Handle of the object that is the source of the event, or an array of source handles.

EventName

Name of the event, which is triggered by the source objects.

callback

Function handle referencing a function to execute when the event is triggered.

property

Character string that can be:

- the name of the property

- a cell array of strings where each string is the name of a property that exists in object array `Hsource`
- a `meta.property` object or an array of `meta.property` objects
- a cell array of `meta.property` objects

If `Hsource` is a scalar, then any of the properties can be dynamic properties. If `Hsource` is non-scalar, then the properties must belong to the class of `Hsource` and can not include dynamic properties (which are not part of the class definition).

For more information, see the following sections:

- The `GetObservable` and `SetObservable` property attributes in the “Property Attributes” table.
- “Creating Property Listeners”
- “Dynamic Properties — Adding Properties to an Instance”

Output Arguments

`lh`

Handle of the `event.listener` object returned by `addlistener`.

Removing a Listener

To remove a listener, delete the listener object returned by `addlistener`. For example,

```
delete(lh)
```

calls the handle class `delete` method to delete the object from the workspace and remove the listener.

When you use `addlistener` to create a listener, redefining the variable containing the handle to the listener does not delete the listener because the event object still has a reference to the `event.listener` object. `addlistener` ties the listener’s lifecycle to the object that is the source of the event. If you want to define a listener that is not tied to the event object, use the `event.listener` constructor directly to create the listener.

addListener (handle)

See Also

delete (handle) | handle | notify (handle)

How To

- “Limiting Listener Scope — Constructing event.listener Objects Directly”

Purpose

Add optional positional argument to input parser scheme

Syntax

```
addOptional(p, argName, default)
addOptional(p, argName, default, validationFcn)
```

Description

`addOptional(p, argName, default)` adds optional input, `argName`, to the input parser scheme of `inputParser` object, `p`. When the inputs that you are checking do not include a value for this optional input, the input parser assigns the `default` value to the input.

`addOptional(p, argName, default, validationFcn)` specifies a validation function for the input argument.

Tips

- For optional string inputs, specify a validation function. Without a validation function, the input parser interprets valid string inputs as invalid parameter names and throws an error.
- Use `addOptional` to add an individual argument into the input parser scheme. If you want to parse an optional name-value pair, use `addParameter`.

Input Arguments

p

Object of class `inputParser`.

argName

String that specifies the internal name for the input argument.

Arguments added with `addOptional` are positional. When you call a function with positional inputs:

- Specify inputs in the same order that they are added into the input parser scheme.
- Specify a value for the k th argument by assigning values for the first $(k - 1)$ arguments in the input scheme.

default

inputParser.addOptional

Default value for the input. This value can be of any data type.

validationFcn

Handle to a function that checks if the input argument is valid.

inputParser accepts two types of validation functions: functions that return true or false, and functions that pass or throw an error. Both types of validation functions must accept a single input argument.

Examples

Add Optional Input

Create an inputParser object and add an optional input named myinput with a default value of 0 to the input scheme.

```
p = inputParser;  
argName = 'myinput';  
default = 0;  
addOptional(p,argName,default);
```

Validate Optional Input

Check whether an optional input named num with a default value of 1 is a numeric scalar greater than zero.

```
p = inputParser;  
argName = 'num';  
default = 1;  
validationFcn = @(x) isnumeric(x) && isscalar(x) && (x > 0);  
addOptional(p,argName,default,validationFcn);
```

The syntax @(x) creates a handle to an anonymous function with one input.

Attempt to parse an invalid input, such as -1:

```
parse(p, -1)
```

```
The value of 'num' is invalid. It must satisfy the function: @(x)isnumeric(x)&&isscalar(x)&&(x>0).
```

Validate Optional Input with validateattributes

Create an inputParser object and define a validation function using validateattributes to test that optional input is numeric, positive, and even. Add the required input to the scheme.

```
p = inputParser;  
argName = 'evenPosNum';  
default = 1;  
validationFcn = @(x) validateattributes(x,{'numeric'},...  
    {'even','positive'});  
addOptional(p,argName,default,validationFcn);
```

Parse an input string. Parse will fail.

```
parse(p, 'hello')
```

The value of 'evenPosNum' is invalid. Expected input to be one of these types:

```
double, single, uint8, uint16, uint32, uint64, int8, int16, int32, int64
```

Instead its type was char.

Parse an odd number. Parse will fail.

```
parse(p, 13)
```

The value of 'evenPosNum' is invalid. Expected input to be even.

Parse an even, positive number. Parse will pass.

```
parse(p, 42)
```

See Also

[addParameter](#) | [addRequired](#) | [inputParser](#) | [function_handle](#) | [validateattributes](#)

Concepts

- “Anonymous Functions”

inputParser.addParameter

Purpose Add optional parameter name-value pair argument to input parser scheme

Syntax

```
addParameter(p,paramName,default)
addParameter(p,paramName,default,validationFcn)
addParameter(__,'PartialMatchPriority',
matchPriorityValue)
```

Description

`addParameter(p,paramName,default)` adds parameter name and value argument `paramName` to the input parser scheme of `inputParser` object, `p`. When the inputs that you are checking do not include a value for this optional parameter, the input parser assigns the `default` value.

`addParameter(p,paramName,default,validationFcn)` specifies a validation function for the input argument.

`addParameter(__,'PartialMatchPriority',matchPriorityValue)` allows specification of `matchPriorityValue` to indicate priority for matching of conflicting partial parameter names and can include any of the input arguments in the previous syntaxes.

Input Arguments

p

Object of class `inputParser`.

paramName

String that specifies the internal name for the input parameter.

Parameter names and values are optional inputs. When calling the function, name and value pairs can appear in any order, with the general form `Name1, Value1, . . . , NameN, ValueN`.

default

Default value for the input. This value can be of any data type.

matchPriorityValue

Positive integer value indicating the priority for matching of conflicting partial parameter names. The input parser selects

lower priority values over higher ones. If, within an input parser scheme, partial parameter names are ambiguous and have the same priority, `inputParser` will throw an error. If the names are ambiguous, but have different `PartialMatchPriority` values, `inputParser` issues a warning indicating the matched name.

Default: 1

validationFcn

Handle to a function that checks if the input argument is valid.

`inputParser` accepts two types of validation functions: functions that return `true` or `false`, and functions that pass or throw an error. Both types of validation functions must accept a single input argument.

Examples

Add Optional Parameter Value Input

Create an `inputParser` object and add an optional input named `myparam` with a default value of 0 to the input scheme.

```
p = inputParser;  
paramName = 'myparam';  
default = 0;  
addParameter(p,paramName,default);
```

Unlike the positional inputs added with the `addRequired` and `addOptional` methods, each parameter added with `addParameter` corresponds to two input arguments: one for the name and one for the value of the parameter.

Pass both the parameter name and value to the `parse` method.

```
parse(p, 'myparam', 100);  
p.Results
```

```
ans =
```

inputParser.AddParameter

```
myparam: 100
```

Validate Parameter Value

Check whether the value corresponding to `myparam` is a numeric scalar greater than zero.

```
p = inputParser;
paramName = 'myparam';
default = 1;
errorStr = 'Value must be positive, scalar, and numeric.';
validationFcn = @(x) assert(isnumeric(x) && isscalar(x) ...
    && (x > 0),errorStr);
addParameter(p,paramName,default,validationFcn);
```

The syntax `@(x)` creates a handle to an anonymous function with one input.

Attempt to parse an invalid value, such as `-1`:

```
parse(p, 'myparam', -1)
```

```
The value of 'myparam' is invalid. Value must be positive, scalar, and numeric.
```

Validate Parameter Value Input with validateattributes

Create an `inputParser` object and define a validation function using `validateattributes` to test that input parameter `myName` is a nonempty string.

```
p = inputParser;
paramName = 'myName';
default = 'John Doe';
validationFcn = @(x) validateattributes(x,{'char'},{'nonempty'});
addParameter(p,paramName,default,validationFcn);
```

Define `myName` as a number. The attempt to parse fails.

```
parse(p, 'myName ', 1138)
```

The value of 'myName' is invalid. Expected input to be one of these types:

char

Instead its type was double.

Parse a string. The attempt to parse passes.

```
parse(p, 'myName ', 'George ')
```

See Also

[addOptional](#) | [addRequired](#) | [inputParser](#) | [function_handle](#) | [validateattributes](#)

Concepts

- “Anonymous Functions”

inputParser.addParamValue

Purpose (Not recommended) Add parameter name and value argument to Input Parser scheme

Compatibility addParamValue is not recommended. Use addParameter instead.

Syntax
addParamValue(p,paramName,default)
addParamValue(p,paramName,default,validationFcn)

Description
addParamValue(p,paramName,default) adds parameter name and value argument paramName to the input scheme of inputParser object p. When the inputs that you are checking do not include a value for this optional parameter, the parser assigns the default value.
addParamValue(p,paramName,default,validationFcn) specifies a validation function for the input argument.

Tips

- If your parameter values do not require validation, you do not have to include them in the input scheme with addParamValue. As an alternative, set the KeepUnmatched property of the inputParser object to true. The parser stores extra parameter names and values in the Unmatched property rather than in the Results property of the object. For an example, see the inputParser reference page.

Input Arguments

p
Object of class inputParser.

paramName
String that specifies the internal name for the input parameter.
Parameter names and values are optional inputs. When calling the function, name and value pairs can appear in any order, with the general form Name1, Value1, . . . , NameN, ValueN.

default
Default value for the input. This value can be of any data type.

validationFcn

Handle to a function that checks if the input argument is valid.

`inputParser` accepts two types of validation functions: functions that return `true` or `false`, and functions that pass or throw an error. Both types of validation functions must accept a single input argument.

Examples

Add Optional Parameter Value Input

Create an `inputParser` object and add an optional input named `myparam` with a default value of 0 to the input scheme.

```
p = inputParser;  
paramName = 'myparam';  
default = 0;  
addParameter(p,paramName,default);
```

Unlike the positional inputs added with the `addRequired` and `addOptional` methods, each parameter added with `addParameter` corresponds to two input arguments: one for the name and one for the value of the parameter.

Pass both the parameter name and value to the `parse` method.

```
parse(p, 'myparam', 100);  
p.Results
```

```
ans =
```

```
    myparam: 100
```

Validate Parameter Value

Check whether the value corresponding to `myparam` is a numeric scalar greater than zero.

```
p = inputParser;
```

inputParser.addParamValue

```
paramName = 'myparam';  
default = 1;  
validationFcn = @(x) isnumeric(x) && isscalar(x) && (x > 0);  
addParamValue(p,paramName,default,validationFcn);
```

The syntax @(x) creates a handle to an anonymous function with one input.

Attempt to parse an invalid value, such as -1:

```
parse(p, 'myparam', -1)
```

```
Argument 'myparam' failed validation @(x)isnumeric(x)&&isscalar(x)&&(x>0)
```

See Also

[addOptional](#) | [addRequired](#) | [inputParser](#) | [function_handle](#)

Concepts

- “Anonymous Functions”

Purpose	Add categories to categorical array
Syntax	<pre>B = addcats(A,newcats) B = addcats(A,newcats, 'Before',beforewhere) B = addcats(A,newcats, 'After',afterwhere)</pre>
Description	<p><code>B = addcats(A,newcats)</code> adds categories to the end of the category list for the input categorical array, <code>A</code>. The output categorical array, <code>B</code>, contains the same values as <code>A</code>. The output, <code>B</code>, does not contain any elements equal to the new categories until you assign values from <code>newcats</code> to elements in <code>B</code>.</p> <p>If <code>A</code> is an ordinal categorical array, you must specify the <code>'Before',beforewhere</code> or <code>'After',afterwhere</code> input arguments.</p> <p><code>B = addcats(A,newcats, 'Before',beforewhere)</code> adds categories before the category specified by <code>beforewhere</code>.</p> <p><code>B = addcats(A,newcats, 'After',afterwhere)</code> adds categories after the category specified by <code>afterwhere</code>.</p>
Input Arguments	<p>A - Categorical array vector matrix multidimensional array</p> <p>Categorical array, specified as a vector, matrix, or multidimensional array.</p> <p>newcats - New categories string cell array of strings</p> <p>New categories, specified as a string or a cell array of strings.</p> <p>beforewhere - Category to precede string</p> <p>Category to precede, specified as a string.</p>

afterwhere - Category to follow

string

Category to follow, specified as a string.

Examples

Add Categories at End

Create a nonordinal categorical array.

```
A = categorical({'republican' 'democrat' 'republican';...  
              'democrat' 'republican' 'democrat'})
```

A =

```
      republican      democrat      republican  
      democrat      republican      democrat
```

Display the categories of A.

```
categories(A)
```

ans =

```
      'democrat'  
      'republican'
```

A is a 2-by-3 categorical array with two categories.

Add the categories, `independent` and `undeclared`, to the end of the category list

```
B = addcats(A,{'independent' 'undeclared'})
```

B =

```
      republican      democrat      republican  
      democrat      republican      democrat
```

B contains the same values as A.

Display the categories of B.

```
categories(B)

ans =

    'democrat'
    'republican'
    'independent'
    'undeclared'
```

B is a 2-by-3 categorical array with four categories.

Add Categories and Specify Category to Precede

Create an ordinal categorical array.

```
A = categorical({'medium' 'large'; 'small' 'xlarge'; 'large' 'medium'},...
    {'small' 'medium' 'large' 'xlarge'}, 'Ordinal', true)
```

```
A =

    medium    large
    small     xlarge
    large     medium
```

Display the categories of A.

```
categories(A)

ans =

    'small'
    'medium'
    'large'
    'xlarge'
```

Since A is ordinal, the categories have the mathematical ordering `small < medium < large < xlarge`.

addcats

Add the category `xsmall` before `small`.

```
B = addcats(A, 'xsmall', 'Before', 'small')
```

```
B =
```

```
      medium      large  
      small      xlarge  
      large      medium
```

B contains the same values as A.

Display the categories of B.

```
categories(B)
```

```
ans =
```

```
'xsmall'  
'small'  
'medium'  
'large'  
'xlarge'
```

The categories have the mathematical ordering `xsmall < small < medium < large < xlarge`.

See Also

```
categories | removecats | iscategory | mergecats | renamecats  
| reordercats
```

Purpose

Add folders to search path

Syntax

```
addpath(folderName1,...,folderNameN)
addpath(folderName1,...,folderNameN,position)

addpath( ____, '-frozen' )

oldpath = addpath( ____ )
```

Description

`addpath(folderName1,...,folderNameN)` adds the specified folders to the top of the search path. Use `addpath` statements in a `startup.m` file to modify the search path programmatically at startup.

`addpath(folderName1,...,folderNameN,position)` adds the specified folders to the top or bottom of the search path, as specified by `position`.

`addpath(____, '-frozen')` additionally disables folder change detection on Windows for folders being added, which conserves Windows change notification resources (Windows only). Type `help changenotification` in the Command Window for more information.

Add `'-frozen'` to the input arguments in any of the previous syntaxes. You can specify `'-frozen'` and `position` in either order.

`oldpath = addpath(____)` additionally returns the path prior to adding the specified folders.

Input Arguments

folderName1,...,folderNameN - Names of folders to add to search path

string

Names of folders to add to the search path, specified as strings. Use the full path name for each folder. Use `genpath` with `addpath` to add all subfolders of `folderName`.

addpath

Example: 'c:\matlab\work'

Example: '/home/user/matlab'

Example: '/home/user/matlab', '/home/user/matlab/test'

position - Position on the search path

'-begin' (default) | '-end'

Position on the search path, specified as one of the following strings.

Value of position	Description
'-begin'	Add specified folders to the top of the search path.
'-end'	Add specified folders to the bottom of the search path.

Output Arguments

oldpath - Path prior to addition of folders

string

Path prior to the addition of folders, returned as a string.

Examples

Add Folder to Top of Search Path

If you do not have a folder called `c:/matlab/myfiles`, create the folder.

```
mkdir('c:/matlab/myfiles')
```

Add `c:/matlab/myfiles` to the top of the search path.

```
addpath('c:/matlab/myfiles')
```

Add Folder to End of Search Path

Add `c:/matlab/myfiles` to the end of the search path.

```
addpath('c:/matlab/myfiles', '-end')
```

Add Folder and Its Subfolders to Search Path

Add `c:/matlab/myfiles` and its subfolders to the search path.

Call `genpath` inside of `addpath` to add all subfolders of `c:/matlab/myfiles` to the search path.

```
addpath(genpath('c:/matlab/myfiles'))
```

Add Folder to Search Path and Disable Folder Change Notification

On Windows, add the folder `c:/matlab/myfiles` to the top of the search path, disable folder change notification, and return the search path before adding the folder.

```
oldpath = addpath('c:/matlab/myfiles', '-frozen');
```

Tips

- If you use `addpath` within a local function, the path change persists after program control returns from the function. That is, the scope of the path change is global.

See Also

`genpath` | `path` | `pathsep` | `rmpath` | `savepath`

Concepts

- “What Is the MATLAB Search Path?”
- “Files and Folders that MATLAB Accesses”
- “Specify File Names”
- “Specifying Startup Options in MATLAB Startup File”

addpref

Purpose

Add preference

Syntax

```
addpref('group','pref',val)
addpref('group',{'pref1','pref2',... 'prefn'},{val1,val2,...valn})
```

Description

`addpref('group','pref',val)` creates the preference specified by `group` and `pref` and sets its value to `val`. It is an error to add a preference that already exists. Individual preference values can be any MATLAB data type, including numeric types, strings, cell arrays, structures, and objects.

`group` labels a related collection of preferences. You can choose any name that is a legal variable name, and is descriptive enough to be unique, e.g. `'ApplicationOnePrefs'`. The input argument `pref` identifies an individual preference in that group, and must be a legal variable name.

`addpref('group',{'pref1','pref2',... 'prefn'},{val1,val2,...valn})` creates the preferences specified by the cell array of names `'pref1'`, `'pref2'`, ..., `'prefn'`, setting each to the corresponding value.

Note Preference values are persistent and maintain their values between MATLAB sessions. Where they are stored is system dependent.

Examples

Add a preference called `version` to the `mytoolbox` group of preferences, setting its value to the cell array `{'1.0','beta'}`.

```
addpref('mytoolbox','version',{'1.0','beta'})
```

Add a preference called `documentation` to the `mytoolbox` group of preferences, setting its value to a struct you define as having four fields:

```
mydoc.docexists = 1;
mydoc.docpath = fullfile(docroot,'techdoc',...
    'matlab_env','examples');
```



```
mydoc.demoexists = 1;
mydoc.demopath = fullfile(docroot,'techdoc',...
    'matlab_env','examples','demo_examples');
addpref('mytoolbox','documentation',mydoc)
% Retrieve the preference with GETPREF
p = getpref('mytoolbox','documentation')

p =
    docexists: 1
    docpath: [1x109 char]
    demoexists: 1
    demopath: [1x123 char]
```

See Also

[getpref](#) | [ispref](#) | [rmpref](#) | [setpref](#) | [uigetpref](#) | [uisetpref](#)

addprop (dynamicprops)

Purpose Add dynamic property

Syntax `P = addprop(Hobj, 'PropName')`

Description `P = addprop(Hobj, 'PropName')` adds a property named `PropName` to each object in array `Hobj`. The class definition is not affected by the addition of dynamic properties. Note that you can add dynamic properties only to objects derived from the `dynamicprops` class. You can set and retrieve the data in dynamic properties as you would any property.

The output argument `P` is an array the same size as `Hobj` of `meta.DynamicProperty` objects, which you can use to assign `SetMethod` and `GetMethod` functions to the property. These functions operate just like property set and get access methods.

See “Dynamic Properties — Adding Properties to an Instance” for more information and examples.

See Also `handle` | `dynamicprops`

Purpose Add custom property to COM object

Syntax `h.addproperty('propertyname')`
`addproperty(h,'propertyname')`

Description `h.addproperty('propertyname')` adds the custom property specified in the string `propertyname` to the object or interface `h`. Use the `COM set` function to assign a value to the property.

`addproperty(h,'propertyname')` is an alternate syntax.

COM functions are available on Microsoft Windows systems only.

Examples Add a custom property to an instance of the MATLAB sample control:

1 Create an instance of the control:

```
f = figure('position', [100 200 200 200]);  
h = actxcontrol('mwsamp.mwsampctrl.2', [0 0 200 200], f);  
h.get
```

MATLAB displays its properties:

```
Label: 'Label'  
Radius: 20
```

2 Add a custom property named `Position` and assign a value:

```
h.addproperty('Position');  
h.Position = [200 120];  
h.get
```

MATLAB displays (in part):

```
Label: 'Label'  
Radius: 20  
Position: [200 120]
```

3 Delete the custom property `Position`:

addproperty

```
h.deleteproperty('Position');  
h.get
```

MATLAB displays the original list of properties:

```
Label: 'Label'  
Radius: 20
```

See Also

[deleteproperty](#) | [get \(COM\)](#) | [set \(COM\)](#) | [inspect](#)

How To

- “Use Object Properties”

Purpose	Add required positional argument to input parser scheme
Syntax	<pre>addRequired(p, argName) addRequired(p, argName, validationFcn)</pre>
Description	<p><code>addRequired(p, argName)</code> adds required argument, <code>argName</code>, to the input parser scheme of <code>inputParser</code> object, <code>p</code>.</p> <p><code>addRequired(p, argName, validationFcn)</code> includes a validation function for the input argument.</p>
Input Arguments	<p>p Object of class <code>inputParser</code>.</p> <p>argName String that specifies the internal name for the input argument. Arguments added with <code>addRequired</code> are positional. When you call a function with positional inputs, you must specify inputs in the order that they are added to the input parser scheme.</p> <p>validationFcn Handle to a function that checks if the input argument is valid. <code>inputParser</code> accepts two types of validation functions: functions that return <code>true</code> or <code>false</code>, and functions that pass or throw an error. Both types of validation functions must accept a single input argument.</p>
Examples	<p>Add Required Input</p> <p>Create an <code>inputParser</code> object and add a required input named <code>myinput</code> to the input scheme.</p> <pre>p = inputParser; argName = 'myinput'; addRequired(p, argName);</pre>

inputParser.addRequired

Validate Required Input

Check whether a required input named `num` is a numeric scalar greater than zero.

```
p = inputParser;
argName = 'num';
validationFcn = @(x) isnumeric(x) && isscalar(x) && (x > 0);
addRequired(p, argName, validationFcn);
```

The syntax `@(x)` creates a handle to an anonymous function with one input.

Attempt to parse an invalid input, such as `-1`:

```
parse(p, -1)
```

The value of 'num' is invalid. It must satisfy the function: `@(x)isnumeric(x)&&isscalar(x)&&(x>0)`.

Validate Required Input with `validateattributes`

Create an `inputParser` object and define a validation function using `validateattributes` to test that required input is numeric, positive, and even. Add the required input to the scheme.

```
p = inputParser;
argName = 'evenPosNum';
validationFcn = @(x) validateattributes(x, {'numeric'}, ...
    {'even', 'positive'});
addRequired(p, argName, validationFcn);
```

Parse an input string. Parse will fail.

```
parse(p, 'hello')
```

The value of 'evenPosNum' is invalid. Expected input to be one of these types:

```
double, single, uint8, uint16, uint32, uint64, int8, int16, int32, int64
```

Instead its type was char.

Parse an odd number. Parse will fail.

```
parse(p,13)
```

The value of 'evenPosNum' is invalid. Expected input to be even.

Parse an even, positive number. Parse will pass.

```
parse(p,42)
```

See Also

[addOptional](#) | [addParameter](#) | [inputParser](#) | [function_handle](#) | [validateattributes](#)

Concepts

- “Anonymous Functions”

addsampletocollection

Purpose Add sample to `tscollection` object

Syntax `tsc = addsampletocollection(tsc, 'time', Time, TS1Name, TS1Data, TSnName, TSnData)`

Description `tsc = addsampletocollection(tsc, 'time', Time, TS1Name, TS1Data, TSnName, TSnData)` adds data samples `TSnData` to the collection member `TSnName` in the `tscollection` object `tsc` at one or more `Time` values. Here, `TSnName` is the string that represents the name of a time series in `tsc`, and `TSnData` is an array containing data samples.

Tips If you do not specify data samples for a time-series member in `tsc`, that time-series member will contain missing data at the times given by `Time` (for numerical time-series data), NaN values, or (for logical time-series data) false values.

When a time-series member requires `Quality` values, you can specify data quality codes together with the data samples by using the following syntax:

```
tsc = addsampletocollection(tsc, 'time', time, TS1Name, ...
    ts1cellarray, TS2Name, ts2cellarray, ...)
```

Specify data in the first cell array element and `Quality` in the second cell array element.

Note If a time-series member already has `Quality` values but you only provide data samples, 0s are added to the existing `Quality` array at the times given by `Time`.

Examples The following example shows how to create a `tscollection` that consists of two `timeseries` objects, where one `timeseries` does not have quality codes and the other does. The final step of the example adds a sample to the `tscollection`.

- 1 Create two `timeseries` objects, `ts1` and `ts2`.

```
ts1 = timeseries([1.1 2.9 3.7 4.0 3.0],1:5,...  
                'name','acceleration');  
ts2 = timeseries([3.2 4.2 6.2 8.5 1.1],1:5,...  
                'name','speed');
```

- 2 Define a dictionary of quality codes and descriptions for `ts2`.

```
ts2.QualityInfo.Code = [0 1];  
ts2.QualityInfo.Description = {'bad','good'};
```

- 3 Assign a quality of code of 1, which is equivalent to 'good', to each data value in `ts2`.

```
ts2.Quality = ones(5,1);
```

- 4 Create a time-series collection `tsc`, which includes time series `ts1` and `ts2`.

```
tsc = tscollection({ts1,ts2});
```

- 5 Add a data sample to the collection `tsc` at 3.5 seconds.

```
tsc = addsampletocollection(tsc,'time',3.5,'acceleration',10,'speed',{5 1});
```

The cell array for the `timeseries` object 'speed' specifies both the data value 5 and the quality code 1.

Note If you do not specify a quality code when adding a data sample to a time series that has quality codes, then the lowest quality code is assigned to the new sample by default.

See Also

`delsamplefromcollection` | `timeseries` | `tscollection`

addtodate

Purpose Modify date number by field

Syntax `R = addtodate(D, Q, F)`

Description `R = addtodate(D, Q, F)` adds quantity `Q` to the indicated date field `F` of a scalar serial date number `D`, returning the updated date number `R`.

The quantity `Q` to be added can be a positive or negative integer. The absolute value of `Q` must be less than or equal to $1e16$. The date field `F` must be a 1-by-`N` character array equal to one of the following: 'year', 'month', 'day', 'hour', 'minute', 'second', or 'millisecond'.

If the addition to the date field causes the field to roll over, the MATLAB software adjusts the next more significant fields accordingly. Adding a negative quantity to the indicated date field rolls back the calendar on the indicated field. If the addition causes the field to roll back, MATLAB adjusts the next less significant fields accordingly.

Examples Modify the hours, days, and minutes of a given date:

```
t = datenum('07-Apr-2008 23:00:00');
datestr(t)
ans =
    07-Apr-2008 23:00:00
```

```
t= addtodate(t, 2, 'hour');
datestr(t)
ans =
    08-Apr-2008 01:00:00
```

```
t= addtodate(t, -7, 'day');
datestr(t)
ans =
    01-Apr-2008 01:00:00
```

```
t= addtodate(t, 59, 'minute');
datestr(t)
ans =
```

```
01-Apr-2008 01:59:00
```

Adding 20 days to the given date in late December causes the calendar to roll over to January of the next year:

```
R = addtodate(datenum('12/24/2007 12:45'), 20, 'day');
```

```
datestr(R)
```

```
ans =
```

```
13-Jan-2008 12:45:00
```

See Also

[date](#) | [datenum](#) | [datestr](#) | [datevec](#)

addts

Purpose Add timeseries object to tscollection object

Syntax

```
tsc = addts(tsc,ts)
tsc = addts(tsc,ts)
tsc = addts(tsc,ts,Name)
tsc = addts(tsc,Data,Name)
```

Description `tsc = addts(tsc,ts)` adds the timeseries object `ts` to tscollection object `tsc`.

`tsc = addts(tsc,ts)` adds a cell array of timeseries objects `ts` to the tscollection `tsc`.

`tsc = addts(tsc,ts,Name)` adds a cell array of timeseries objects `ts` to tscollection `tsc`. `Name` is a cell array of strings that gives the names of the timeseries objects in `ts`.

`tsc = addts(tsc,Data,Name)` creates a new timeseries object from `Data` with the name `Name` and adds it to the tscollection object `tsc`. `Data` is a numerical array and `Name` is a string.

Tips The timeseries objects you add to the collection must have the same time vector as the collection. That is, the time vectors must have the same time values and units.

Suppose that the time vector of a timeseries object is associated with calendar dates. When you add this timeseries to a collection with a time vector without calendar dates, the time vectors are compared based on the units and the values relative to the `StartDate` property. For more information about properties, see the timeseries reference page.

Examples The following example shows how to add a time series to a time-series collection:

1 Create two timeseries objects, `ts1` and `ts2`.

```
ts1 = timeseries([1.1 2.9 3.7 4.0 3.0],1:5,...
                'name','acceleration');
```

```
ts2 = timeseries([3.2 4.2 6.2 8.5 1.1],1:5,...  
                'name','speed');
```

- 2** Create a time-series collection `tsc`, which includes `ts1`.

```
tsc = tscollection(ts1);
```

- 3** Add `ts2` to the `tsc` collection.

```
tsc = addts(tsc, ts2);
```

- 4** To view the members of `tsc`, type

```
tsc
```

at the MATLAB prompt. the response is

```
Time Series Collection Object: unnamed
```

```
Time vector characteristics
```

```
Start time      1 seconds  
End time        5 seconds
```

```
Member Time Series Objects:
```

```
acceleration  
speed
```

The members of `tsc` are listed by name at the bottom: `acceleration` and `speed`. These are the `Name` properties of the `timeseries` objects `ts1` and `ts2`, respectively.

See Also

`removets` | `tscollection`

airy

Purpose Airy Functions

Syntax
 $W = \text{airy}(Z)$
 $W = \text{airy}(k, Z)$
 $W = \text{airy}(k, Z, \text{scale})$

Description $W = \text{airy}(Z)$ returns the Airy function, $Ai(Z)$, for each element of Z .

$W = \text{airy}(k, Z)$ returns any of four different Airy functions, depending on the value of k , such as the Airy function of the second kind or the first derivative of an Airy function.

$W = \text{airy}(k, Z, \text{scale})$ scales the resulting Airy function. `airy` applies a specific scaling function to W depending on your choice of k and `scale`.

Input Arguments

Z - System variable

vector | matrix | N-D Array

System variable, specified as a real or complex vector, matrix, or N-D array.

Data Types

single | double

Complex Number Support: Yes

k - Type of Airy function

0 (default) | 1 | 2 | 3

Type of Airy function, specified as one of four values.

k	Returns
0	Airy function, $Ai(Z)$, which is the same as <code>airy(Z)</code> .
1	First derivative of Airy function, $Ai'(Z)$.

k	Returns
2	Airy function of the second kind, $Bi(Z)$
3	First derivative of Airy function of the second kind, $Bi'(Z)$

Data Types

single | double

scale - Scaling option

0 (default) | 1

Scaling option, specified as 0 or 1. Use `scale = 1` to enable the scaling of Z. The values you specify for k and scale determine the scaling function airy applies to Z.

scale	k	Scaling applied to output
0	Any	None
1	0 or 1	$e^{\frac{2}{3}Z^{(3/2)}}$
1	2 or 3	$e^{-\left \frac{2}{3}Re(Z^{(3/2)})\right }$

Data Types

single | double

Output Arguments

W - Airy function of z

vector | matrix | N-D Array

Airy function of Z, returned as an array the same size as Z.

Definitions

Airy Functions

The Airy functions form a pair of linearly independent solutions to

$$\frac{d^2W}{dZ^2} - ZW = 0.$$

The relationship between the Airy and modified Bessel functions is

$$Ai(Z) = \left[\frac{1}{\pi} \sqrt{\frac{Z}{3}} \right] K_{1/3}(\zeta)$$
$$Bi(Z) = \sqrt{\frac{Z}{3}} [I_{-1/3}(\zeta) + I_{1/3}(\zeta)],$$

where

$$\zeta = \frac{2}{3} Z^{3/2}.$$

Examples

Airy Function of Real-Valued x

Define x.

```
x = -10:0.01:1;
```

Calculate $Ai(x)$

```
ai = airy(x);
```

Calculate $Bi(x)$ using $k = 2$.

```
bi = airy(2,x);
```

Plot both results together on the same axes.

```
figure  
plot(x,ai,'-b',x,bi,'-r');
```



```
axis([-10 1 -0.6 1.4]);
xlabel('x');
legend('Ai(x)', 'Bi(x)', 'Location', 'NorthWest');
```

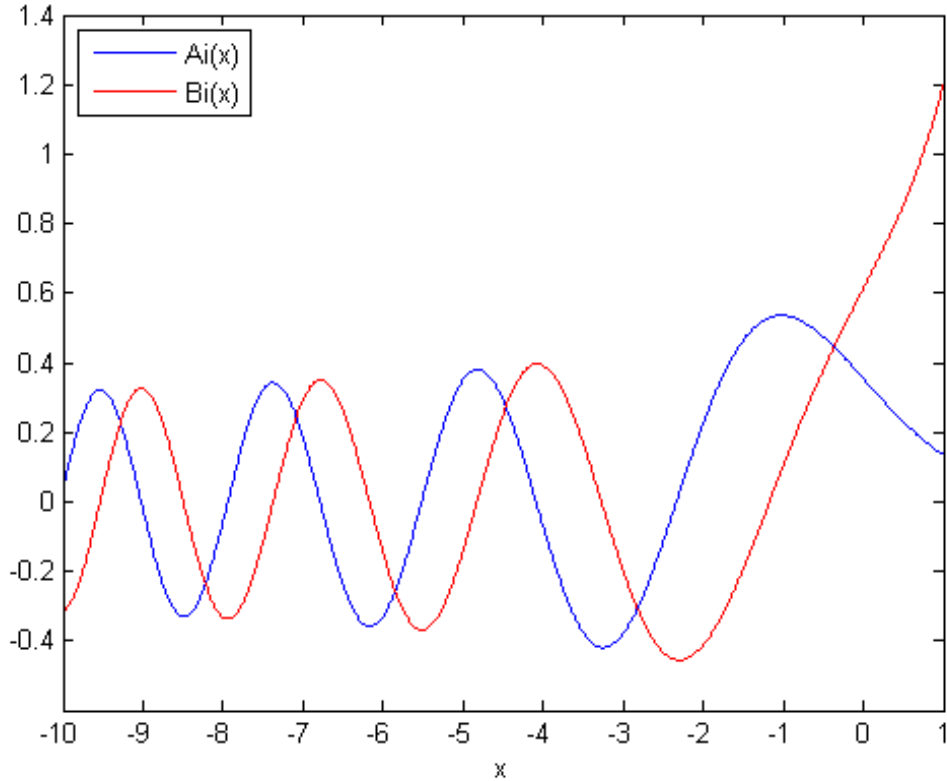

Airy Function of Complex-Valued x

Compute the Airy function at a slice through the complex plane at $x + i$.

Take a slice through the complex plane.

```
x = -4:0.1:4;  
z = x+1i;
```

Calculate $Ai(z)$.

```
w = airy(z);
```

Plot the real part of the result.

```
figure  
plot(x, real(w));  
axis([-4 4 -1.5 1]);  
xlabel('real(z)');
```

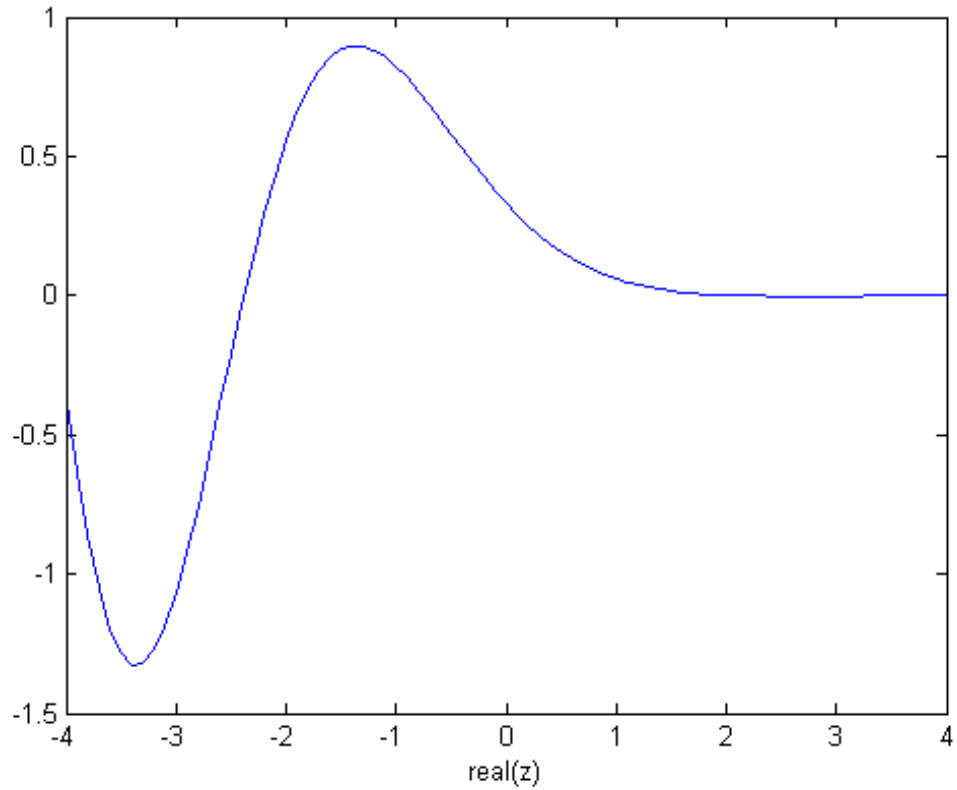

Scaled Airy Function

Define x.

```
x = -10:0.01:1;
```

Calculate the scaled and unscaled Airy function.

```
scaledAi = airy(0,x,1);
noscaleAi = airy(0,x,0);
```

Plot the real part of each result.

```
rscaled = real(scaledAi);  
rnoscale = real(noscaleAi);  
figure  
plot(x,rscaled,'-b',x,rnoscale,'-r');  
axis([-10 1 -0.60 0.60]);  
xlabel('x');  
legend('scaled','not scaled','Location','SouthEast');
```

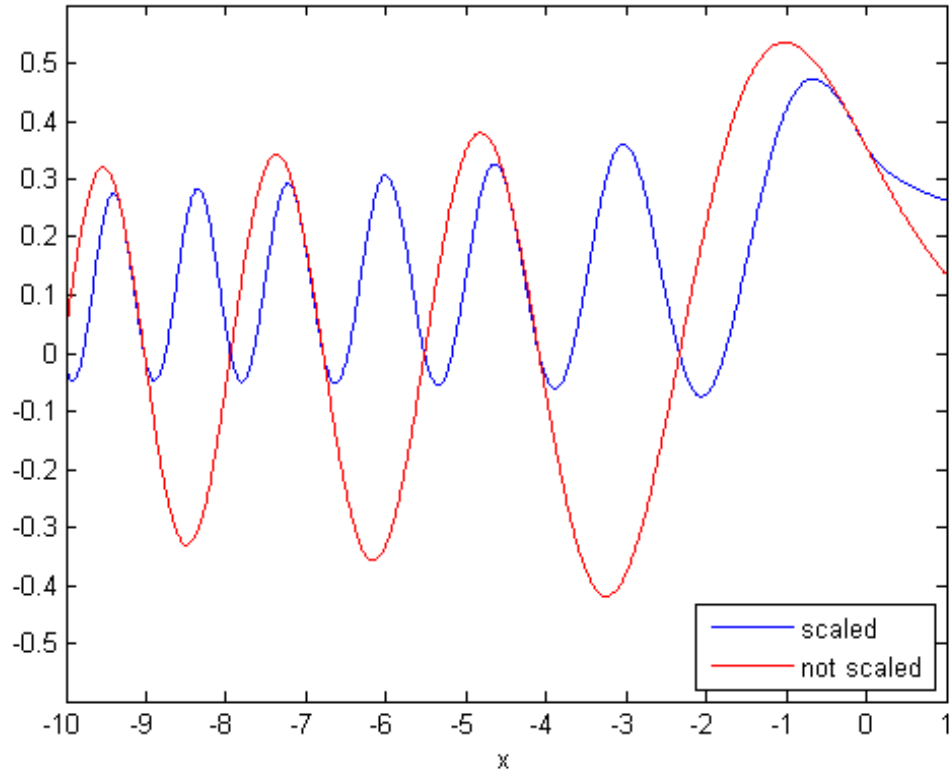
**See Also**[besseli](#) | [besselj](#) | [besselk](#) | [bessely](#) | [besselh](#)

align

Purpose

Align user interface controls (uicontrols) and axes

Syntax

```
align(HandleList,'HorizontalAlignment','VerticalAlignment')
Positions = align(HandleList, 'HorizontalAlignment',
    'VerticalAlignment')
Positions = align(CurPositions, 'HorizontalAlignment',
    'VerticalAlignment')
```

Description

`align(HandleList,'HorizontalAlignment','VerticalAlignment')` aligns the `uicontrol` and `axes` objects in `HandleList`, a vector of handles, according to the options `HorizontalAlignment` and `VerticalAlignment`. The following tables show the possible values for `HorizontalAlignment` and `VerticalAlignment`.

HorizontalAlignment	Definition
None	No horizontal alignment
Left	Shifts the objects' left edges to that of the first object selected
Center	Shifts objects to center their positions to the average of the extreme <i>x</i> -values of the group
Right	Shifts the objects' right edges to that of the first object selected
Distribute	Equalizes <i>x</i> -distances between all objects within the span of the extreme <i>x</i> -values
Fixed	Spaces objects to have a specified number of points between them in the <i>y</i> -direction

VerticalAlignment	Definition
None	No vertical alignment
Top	Shifts the objects' top edges to that of the first object selected

VerticalAlignment	Definition
Middle	Shifts objects to center their positions to the average of the extreme <i>y</i> -values of the group
Bottom	Shifts the objects' bottom edges to that of the first object selected
Distribute	Equalizes <i>y</i> -distances between all objects within the span of the extreme <i>y</i> -values
Fixed	Spaces objects to have a specified number of points between them in the <i>x</i> -direction

Aligning objects does not change their absolute sizes. All alignment options align the objects within the bounding box that encloses the objects. `Distribute` and `Fixed` align objects to the bottom left of the bounding box. `Distribute` evenly distributes the objects while `Fixed` distributes the objects with a fixed distance (in points) between them. When you specify both horizontal and vertical distance together, the keywords '`HorizontalAlignment`' and '`VerticalAlignment`' are not necessary.

If you use `Fixed` for `HorizontalAlignment` or `VerticalAlignment`, you must also specify the distance, in points, where 72 points equals 1 inch. For example:

```
align(HandleList, 'Fixed', Distance, 'VerticalAlignment')
```

distributes the specified components *Distance* points horizontally and aligns them vertically as specified.

```
align(HandleList, 'HorizontalAlignment', 'Fixed', Distance)
```

aligns the specified components horizontally as specified and distributes them *Distance* points vertically.

```
align(HandleList, 'Fixed', HorizontalDistance, ...
      'Fixed', VerticalDistance)
```

distributes the specified components `HorizontalDistance` points horizontally and distributes them `VerticalDistance` points vertically.

`Positions = align(HandleList, 'HorizontalAlignment', 'VerticalAlignment')` returns updated positions for the specified objects as a vector of `Position` vectors. The position of the objects on the figure does not change.

`Positions = align(CurPositions, 'HorizontalAlignment', 'VerticalAlignment')` returns updated positions for the objects whose positions are contained in `CurPositions`, where `CurPositions` is a vector of `Position` vectors. The position of the objects on the figure does not change.

Examples

Create a GUI with three buttons and use `align` to line up the buttons.

```
% Create a figure window and one button object:
f=figure;
u1 = uicontrol('Style','push', 'parent', f,'pos',...
[20 100 100 100],'string','button1');
% Create two more button objects, not aligned with
% each other or any part of the figure window:
u2 = uicontrol('Style','push', 'parent', f,'pos',...
[150 250 100 100],'string','button2');
u3 = uicontrol('Style','push', 'parent', f,'pos',...
[250 100 100 100],'string','button3');
% Align the button objects with the bottom of the first
% button object, equalizing the distance between the
% objects within the span of the extreme x-values:
align([u1 u2 u3],'distribute','bottom');
```

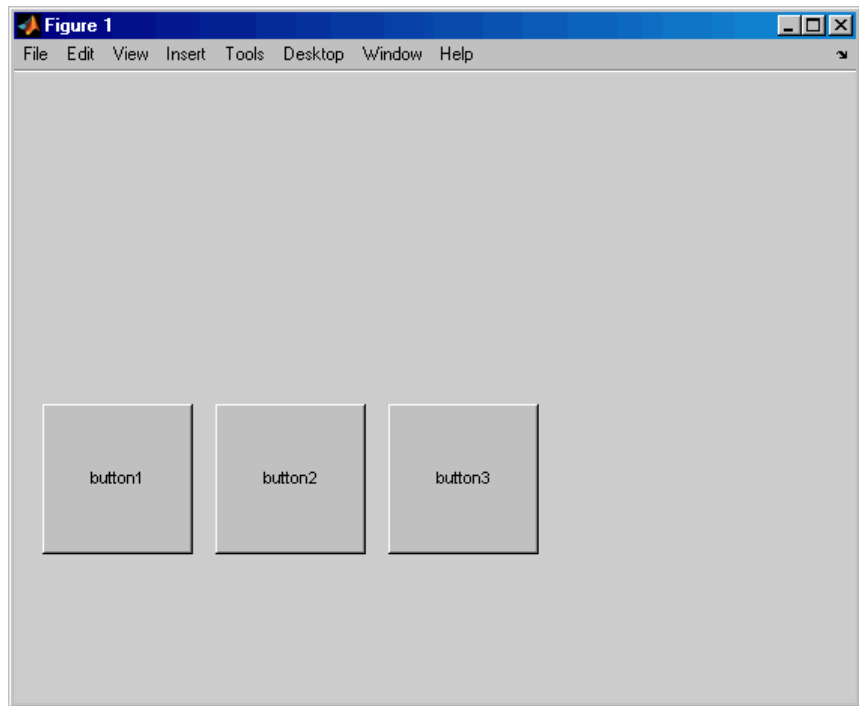
**Alternatives**

See “Alignment Tool — Aligning and Distributing Objects” for the GUI alternative.

See Also

`uicontrol` | `uistack`

Purpose Set or query axes alpha limits

Syntax

```
alpha_limits = alim
alim([amin amax])
alim_mode = alim('mode')
alim('alim_mode')
alim(axes_handle,...)
```

Description `alpha_limits = alim` returns the alpha limits (ALim property) of the current axes.

`alim([amin amax])` sets the alpha limits to the specified values. `amin` is the value of the data mapped to the first alpha value in the alphamap, and `amax` is the value of the data mapped to the last alpha value in the alphamap. Data values in between are linearly interpolated across the alphamap, while data values outside are clamped to either the first or last alphamap value, whichever is closest.

`alim_mode = alim('mode')` returns the alpha limits mode (ALimMode property) of the current axes.

`alim('alim_mode')` sets the alpha limits mode on the current axes. `alim_mode` can be

- `auto` — MATLAB automatically sets the alpha limits based on the alpha data of the objects in the axes.
- `manual` — MATLAB does not change the alpha limits.

`alim(axes_handle,...)` operates on the specified axes.

Examples

Map transparency to a surface plot of z-data and change the `alim` property to make all values below zero transparent:

```
[x,y] = meshgrid([-2:.2:2]);
z = x.*exp(-x.^2-y.^2);
% Plot the data, using the gradient of z as
% the alphamap:
surf(x,y,z+.001,'FaceAlpha','flat',...
'AlphaDataMapping','scaled',...)
```

```
'AlphaData',gradient(z),...  
'FaceColor','blue');  
axis tight  
% Adjust the alim property to see only where  
% the gradient is between 0 and 0.15:  
alim([0 .15])
```

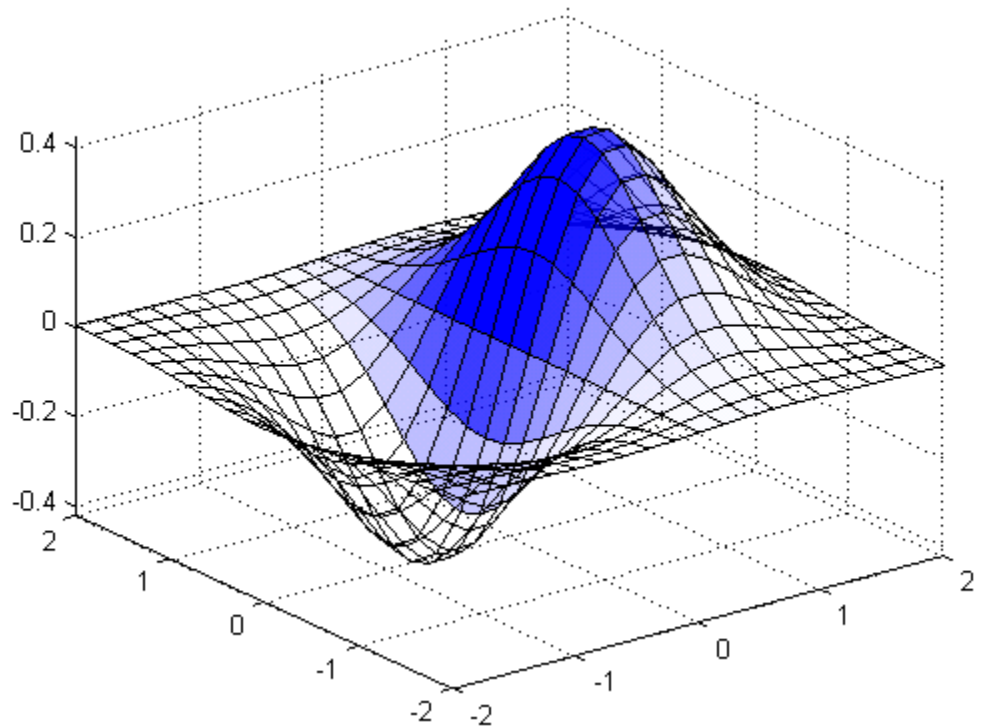

See Also

[alpha](#) | [alphanmap](#) | [caxis](#) | [Axes: ALim](#) | [Axes: ALimMode](#) | [Surface: AlphaData](#) | [Patch: FaceVertexAlphaData](#)

Tutorials

- “Making Objects Transparent”

all

Purpose Determine if all array elements are nonzero or true

Syntax
B = all(A)
B = all(A,dim)

Description B = all(A) tests along the first array dimension of A whose size does not equal 1, and determines if the elements are all nonzero or logical 1 (true). In practice, all is a natural extension of the logical AND operator.

- If A is a vector, then all(A) returns logical 1 (true) if all the elements are nonzero and returns logical 0 (false) if one or more elements are zero.
- If A is a nonempty, nonvector matrix, then all(A) treats the columns of A as vectors and returns a row vector of logical 1s and 0s.
- If A is an empty 0-by-0 matrix, then all(A) returns logical 1 (true).
- If A is a multidimensional array, then all(A) acts along the first array dimension whose size does not equal 1 and returns an array of logical values. The size of this dimension becomes 1, while the sizes of all other dimensions remain the same.

B = all(A,dim) tests elements along dimension dim. The dim input is a positive integer scalar.

Input Arguments

A - Input Array
scalar | vector | matrix | multidimensional array

Input array, specified as a scalar, vector, matrix, or multidimensional array.

Data Types
single | double | int8 | int16 | int32 | int64 | uint8 |
uint16 | uint32 | uint64 | logical | char

Complex Number Support: Yes

dim - Dimension to operate along

positive integer scalar

Dimension to operate along, specified as a positive integer scalar. If no value is specified, the default is the first array dimension whose size does not equal 1.

Consider a two-dimensional input array, A:

- `all(A,1)` works on successive elements in the columns of A and returns a row vector of logical values.
- `all(A,2)` works on successive elements in the rows of A and returns a column vector of logical values.

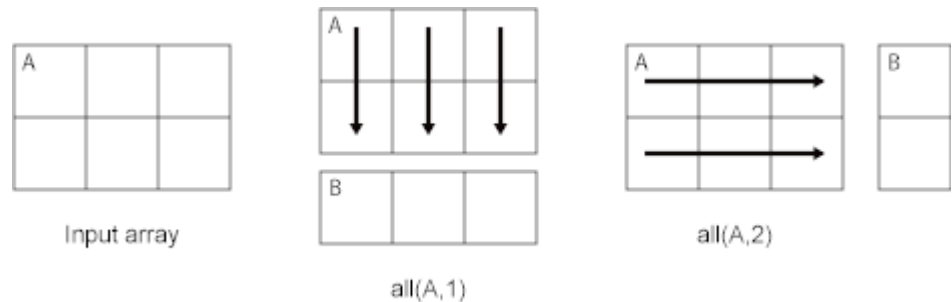

Data Types

double | single | int8 | int16 | int32 | int64 | uint8 |
uint16 | uint32 | uint64

Output Arguments

B - Logical array

scalar | vector | matrix | multidimensional array

Logical array, returned as a scalar, vector, matrix, or multidimensional array. The dimension of A acted on by `all` has size 1 in B.

Examples

Test Matrix Columns

Create a 3-by-3 matrix.

```
A = [0 0 3;0 0 3;0 0 3]
```

```
A =  
  
    0     0     3  
    0     0     3  
    0     0     3
```

Test each column for all nonzero elements.

```
B = all(A)
```

```
B =  
  
    0     0     1
```

Reduce a Logical Vector to a Single Condition

Create a vector of decimal values and test which values are less than 0.5.

```
A = [0.53 0.67 0.01 0.38 0.07 0.42 0.69];  
B = (A < 0.5)
```

```
B =  
  
0  0  1  1  1  1  0
```

The output is a vector of logical values. The `all` function reduces such a vector of logical values to a single condition. In this case, `B = all(A < 0.5)` yields logical 0.

This makes `all` particularly useful in `if` statements.

```
if all(A < 0.5)  
    %do something  
else  
    %do something else  
end
```

The code is executed depending on a single condition, rather than a vector of possibly conflicting conditions.

Test Arrays of Any Dimension

Create a 3-by-7-by-5 multidimensional array and test to see if all of its elements are less than 3.

```
A = rand(3,7,5) * 5;  
B = all(A(:) < 3)
```

```
B =
```

```
0
```

You can also test the array for elements that are greater than zero.

```
B = all(A(:) > 0)
```

```
B =
```

```
1
```

The syntax `A(:)` turns the elements of `A` into a single column vector, so you can use this type of statement on an array of any size.

Test Matrix Rows

Create a 3-by-3 matrix.

```
A = [0 0 3;0 0 3;0 0 3]
```

```
A =
```

```
0     0     3  
0     0     3  
0     0     3
```

Test the rows of `A` for all nonzero elements by specifying `dim = 2`.

all

```
B = all(A,2)
```

```
B =
```

```
0  
0  
0
```

See Also

any | and | colon (:) | prod | sum

Concepts

- “Reduce Logical Arrays to Single Value”

Purpose Find all children of specified objects

Syntax `child_handles = allchild(handle_list)`

Description `child_handles = allchild(handle_list)` returns the list of all children (including ones with hidden handles) for each handle. If `handle_list` is a single element, `allchild` returns the output in a vector. If `handle_list` is a vector of handles, the output is a cell array.

Examples Compare the results these two statements return:

```
axes  
get(gca, 'Children')  
allchild(gca)
```

See Also `findall` | `findobj`

alpha

Purpose Set transparency properties for objects in current axes

Syntax

```
alpha
alpha(object_handle,value)
alpha(face_alpha)
alpha(alpha_data)
alpha(alpha_data)
alpha(alpha_data_mapping)
```

Description alpha sets one of three transparency properties, depending on what arguments you specify with the call to this function. For available arguments, see Inputs.

alpha(object_handle,value) sets the transparency property only on the object identified by object_handle.

Input Arguments

Face Alpha

alpha(face_alpha) sets the FaceAlpha property of all image, patch, and surface objects in the current axes. You can set face_alpha to

scalar	Set the FaceAlpha property to the specified value (for images, set the AlphaData property to the specified value).
'flat'	Set the FaceAlpha property to flat.
'interp'	Set the FaceAlpha property to interp.
'texture'	Set the FaceAlpha property to texture.
'opaque'	Set the FaceAlpha property to 1.
'clear'	Set the FaceAlpha property to 0.

See “Specifying Transparency” for more information.

AlphaData (Surface Objects)

alpha(alpha_data) sets the AlphaData property of all surface objects in the current axes. You can set alpha_data to

matrix the same size as CData	Set the AlphaData property to the specified values.
'x'	Set the AlphaData property to be the same as XData.
'y'	Set the AlphaData property to be the same as YData.
'z'	Set the AlphaData property to be the same as ZData.
'color'	Set the AlphaData property to be the same as CData.
'rand'	Set the AlphaData property to a matrix of random values equal in size to CData.

AlphaData (Image Objects)

`alpha(alpha_data)` sets the AlphaData property of all image objects in the current axes. You can set `alpha_data` to

matrix the same size as CData	Set the AlphaData property to the specified value.
'x'	Ignored.
'y'	Ignored.
'z'	Ignored.
'color'	Set the AlphaData property to be the same as CData.
'rand'	Set the AlphaData property to a matrix of random values equal in size to CData.

AlphaDataMapping

`alpha(alpha_data_mapping)` sets the AlphaDataMapping property of all image, patch, and surface objects in the current axes. You can set `alpha_data_mapping` to

alpha

- 'scaled' Set the AlphaDataMapping property to scaled.
- 'direct' Set the AlphaDataMapping property to direct.
- 'none' Set the AlphaDataMapping property to none.

Examples

Create a surface plot and change its transparency using alpha:

```
surf(peaks);  
alpha(0.5);
```

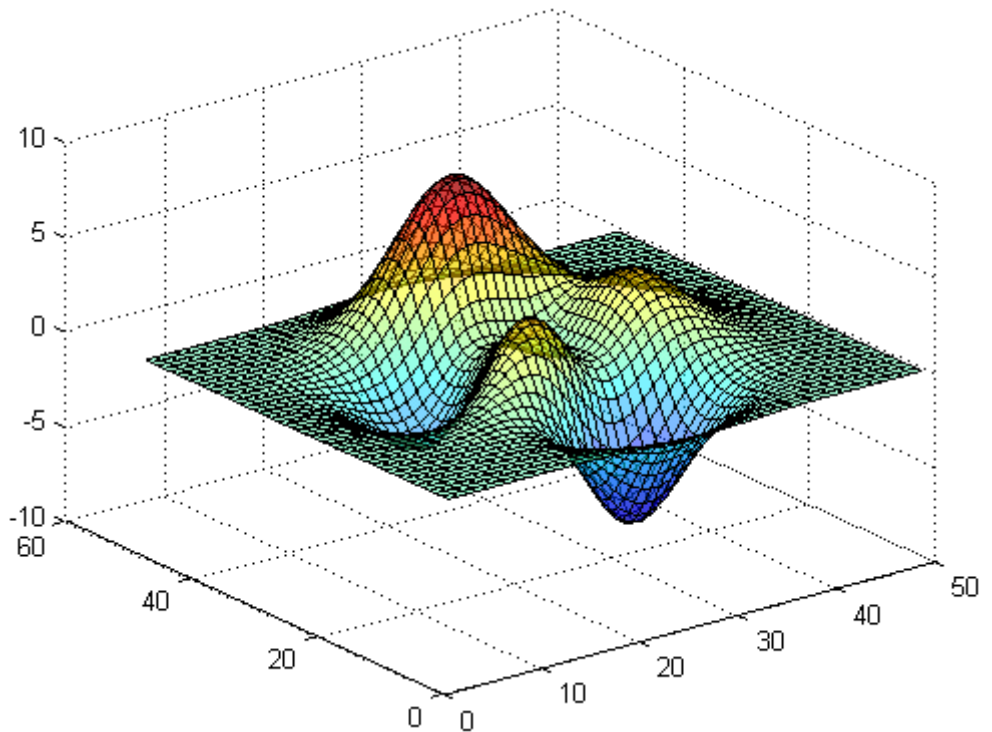

See Also

alim | alphamap | Image: AlphaData | Image: AlphaDataMapping
| Patch: FaceAlpha | Patch: FaceVertexAlphaData | Patch:
AlphaDataMapping | Surface: FaceAlpha | Surface: AlphaData |
Surface: AlphaDataMapping

Tutorials

- “Making Objects Transparent”

alphamap

Purpose Specify figure alphamap (transparency)

Syntax

```
alphamap(alpha_map)
alphamap('parameter')
alphamap('parameter',length)
alphamap('parameter',delta)
alphamap(figure_handle,...)
alpha_map = alphamap
alpha_map = alphamap(figure_handle)
alpha_map = alphamap('parameter')
```

Description `alphamap(alpha_map)` sets the AlphaMap of the current figure to the specified m-by-1 array of alpha values, `alpha_map`.

`alphamap('parameter')` creates a new alphamap or modifies the current alphamap. You can specify the following parameters:

- 'default' — Set the AlphaMap property to the figure's default alphamap.
- 'rampup' — Create a linear alphamap with increasing opacity (default length equals the current alphamap length).
- 'rampdown' — Create a linear alphamap with decreasing opacity (default length equals the current alphamap length).
- 'vup' — Create an alphamap that is opaque in the center and becomes more transparent linearly towards the beginning and end (default length equals the current alphamap length).
- 'vdown' — Create an alphamap that is transparent in the center and becomes more opaque linearly towards the beginning and end (default length equals the current alphamap length).
- 'increase' — Modify the alphamap making it more opaque (default delta is .1, added to the current values).
- 'decrease' — Modify the alphamap making it more transparent (default delta is .1, subtracted from the current values).

- 'spin' — Rotate the current alphamap (default delta is 1; delta must be an integer).

`alphamap('parameter',length)` creates a new alphamap with the length specified by the integer `length` (used with parameters 'rampup', 'rampdown', 'vup', 'vdown').

`alphamap('parameter',delta)` modifies the existing alphamap using the value specified by the integer `delta` (used with parameters 'increase', 'decrease', 'spin').

`alphamap(figure_handle,...)` performs the operation on the alphamap of the figure identified by `figure_handle`.

`alpha_map = alphamap` returns the current alphamap.

`alpha_map = alphamap(figure_handle)` returns the current alphamap from the figure identified by `figure_handle`.

`alpha_map = alphamap('parameter')` returns the alphamap modified by the parameter, but does not set the AlphaMap property.

Examples

Create a surface plot and change the alphamap

```
[x,y] = meshgrid([-2:.2:2]);
z = x.*exp(-x.^2-y.^2);
% Plot the data, using the gradient of z as
% the alphamap:
surf(x,y,z+.001,'FaceAlpha','flat',...
'AlphaDataMapping','scaled',...
'AlphaData',gradient(z),...
'FaceColor','blue');
% Change the alphamap to be opaque at the middle and
% transparent towards the ends:
alphamap('vup')
```

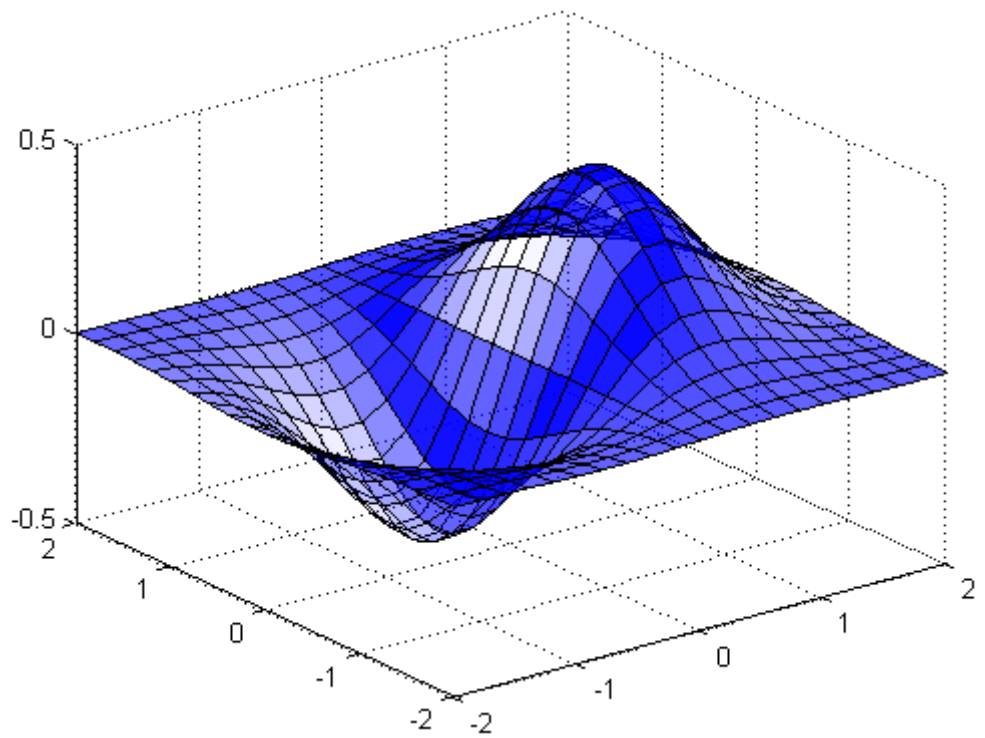

See Also

[alim](#) | [alpha](#) | [Image: AlphaData](#) | [Image: AlphaDataMapping](#)
| [Patch: FaceAlpha](#) | [Patch: FaceVertexAlphaData](#) | [Patch: AlphaDataMapping](#) | [Surface: FaceAlpha](#) | [Surface: AlphaData](#) | [Surface: AlphaDataMapping](#)

Tutorials

- “Making Objects Transparent”

Purpose

Approximate minimum degree permutation

Syntax

```
P = amd(A)
P = amd(A,opts)
```

Description

`P = amd(A)` returns the approximate minimum degree permutation vector for the sparse matrix $C = A + A'$. The Cholesky factorization of $C(P,P)$ or $A(P,P)$ tends to be sparser than that of C or A . The `amd` function tends to be faster than `symamd`, and also tends to return better orderings than `symamd`. Matrix A must be square. If A is a full matrix, then `amd(A)` is equivalent to `amd(sparse(A))`.

`P = amd(A,opts)` allows additional options for the reordering. The `opts` input is a structure with the two fields shown below. You only need to set the fields of interest:

- **dense** — A nonnegative scalar value that indicates what is considered to be dense. If A is n -by- n , then rows and columns with more than $\max(16, (\text{dense} * \sqrt{n}))$ entries in $A + A'$ are considered to be "dense" and are ignored during the ordering. MATLAB software places these rows and columns last in the output permutation. The default value for this field is 10.0 if this option is not present.
- **aggressive** — A scalar value controlling aggressive absorption. If this field is set to a nonzero value, then aggressive absorption is performed. This is the default if this option is not present.

MATLAB software performs an assembly tree post-ordering, which is typically the same as an elimination tree post-ordering. It is not always identical because of the approximate degree update used, and because "dense" rows and columns do not take part in the post-order. It is well-suited for a subsequent `chol` operation, however, If you require a precise elimination tree post-ordering, you can use the following code:

```
P = amd(S);
C = spones(S)+spones(S');
[ignore, Q] = etree(C(P,P));
P = P(Q);
```

If S is already symmetric, omit the second line, $C = \text{spones}(S) + \text{spones}(S')$.

Examples

This example constructs a sparse matrix and computes a two Cholesky factors: one of the original matrix and one of the original matrix preordered by `amd`. Note how much sparser the Cholesky factor of the preordered matrix is compared to the factor of the matrix in its natural ordering:

```
A = gallery('wathen',50,50);
p = amd(A);
L = chol(A,'lower');
Lp = chol(A(p,p),'lower');

figure;
subplot(2,2,1); spy(A);
title('Sparsity structure of A');

subplot(2,2,2); spy(A(p,p));
title('Sparsity structure of AMD ordered A');

subplot(2,2,3); spy(L);
title('Sparsity structure of Cholesky factor of A');

subplot(2,2,4); spy(Lp);
title('Sparsity structure of Cholesky factor of AMD ordered A');

set(gcf,'Position',[100 100 800 700]);
```

See Also

`colamd` | `colperm` | `symamd` | `symrcm`

Purpose

Ancestor of graphics object

Syntax

```
p = ancestor(h,type)
p = ancestor(h,type,'toplevel')
```

Description

`p = ancestor(h,type)` returns the handle of the closest ancestor of `h`, if the ancestor is one of the types of graphics objects specified by `type`. `type` can be:

- a string that is the name of a single type of object. For example, 'figure'
- a cell array containing the names of multiple objects. For example, {'hgtransform','hgroup','axes'}

If MATLAB cannot find an ancestor of `h` that is one of the specified types, then `ancestor` returns `p` as empty. When `ancestor` searches the hierarchy, it includes the object itself in the search. Therefore, if the object with handle `h` is of one of the types listed in `type`, `ancestor` will return object `h`.

`ancestor` returns `p` as empty but does not issue an error if `h` is not the handle of a Handle Graphics object.

`p = ancestor(h,type,'toplevel')` returns the highest-level ancestor of `h`, if this type appears in the `type` argument.

Examples

Find the ancestors of a line object:

```
% Create some line objects and parent them
% to an hgroup object.
hgg = hgroup;
hgl = line(randn(5),randn(5),'Parent',hgg);
% Now get the ancestor of the lines:
p = ancestor(hgg,{'figure','axes','hgroup'});
get(p,'Type')
% Now get the top-level ancestor:
ptop=ancestor(hgg,{'figure','axes','hgroup'],'toplevel');
get(ptop,'type')
```

ancestor

See Also

`findobj`

Purpose Find logical AND

Syntax A & B & ...
and(A, B)

Description A & B & ... performs a logical AND of all input arrays A, B, etc., and returns an array containing elements set to either logical 1 (true) or logical 0 (false). An element of the output array is set to 1 if all input arrays contain a nonzero element at that same array location. Otherwise, that element is set to 0.

Each input of the expression can be an array or can be a scalar value. All nonscalar input arrays must have equal dimensions. If one or more inputs are an array, then the output is an array of the same dimensions. If all inputs are scalar, then the output is scalar.

If the expression contains both scalar and nonscalar inputs, then each scalar input is treated as if it were an array having the same dimensions as the other input arrays. In other words, if input A is a 3-by-5 matrix and input B is the number 1, then B is treated as if it were a 3-by-5 matrix of ones.

and(A, B) is called for the syntax A & B when either A or B is an object.

Note The symbols & and && perform different operations in the MATLAB software. The element-wise AND operator described here is &. The short-circuit AND operator is &&.

Examples If matrix A is

0.4235	0.5798	0	0.7942	0
0.5155	0	0.7833	0.0592	0.8744
0.3340	0	0	0	0.0150
0.4329	0.6405	0.6808	0.0503	0

and matrix B is

and, &

0	1	0	1	0
1	1	1	0	1
0	1	1	1	0
0	1	0	0	1

then

A & B

ans =

0	1	0	1	0
1	0	1	0	1
0	0	0	0	0
0	1	0	0	0

See Also

any | all | bitand | Logical Operators: Short Circuit | xor
| or | not

Concepts

- “Truth Table for Logical Operations”

Purpose	Phase angle
Syntax	$P = \text{angle}(Z)$
Description	<p>$P = \text{angle}(Z)$ returns the phase angles, in radians, for each element of complex array Z. The angles lie between $\pm\pi$.</p> <p>For complex Z, the magnitude R and phase angle θ are given by</p> $R = \text{abs}(Z)$ $\theta = \text{angle}(Z)$ <p>and the statement</p> $Z = R \cdot \exp(i \cdot \theta)$ <p>converts back to the original complex Z.</p>
Examples	$Z = \begin{bmatrix} 1 - 1i & 2 + 1i & 3 - 1i & 4 + 1i \\ 1 + 2i & 2 - 2i & 3 + 2i & 4 - 2i \\ 1 - 3i & 2 + 3i & 3 - 3i & 4 + 3i \\ 1 + 4i & 2 - 4i & 3 + 4i & 4 - 4i \end{bmatrix}$ $P = \text{angle}(Z)$ $P = \begin{bmatrix} -0.7854 & 0.4636 & -0.3218 & 0.2450 \\ 1.1071 & -0.7854 & 0.5880 & -0.4636 \\ -1.2490 & 0.9828 & -0.7854 & 0.6435 \\ 1.3258 & -1.1071 & 0.9273 & -0.7854 \end{bmatrix}$
Algorithms	The angle function can be expressed as $\text{angle}(z) = \text{imag}(\log(z)) = \text{atan2}(\text{imag}(z), \text{real}(z))$.
See Also	<code>abs</code> <code>atan2</code> <code>unwrap</code>

annotation

Purpose Create annotation objects

Syntax

```
annotation(annotation_type)
annotation('line',x,y)
annotation('arrow',x,y)
annotation('doublearrow',x,y)
annotation('textarrow',x,y)
annotation('textbox',[x y w h])
annotation('ellipse',[x y w h])
annotation('rectangle',[x y w h])
annotation(figure_handle,...)
annotation(...,'PropertyName',PropertyValue,...)
anno_obj_handle = annotation(...)
```

Description `annotation(annotation_type)` creates the specified annotation type using default values for all properties. *annotation_type* can be one of the following strings:

- 'line'
- 'arrow'
- 'doublearrow' (two-headed arrow),
- 'textarrow' (arrow with attached text box),
- 'textbox'
- 'ellipse'
- 'rectangle'

`annotation('line',x,y)` creates a line annotation object that extends from the point defined by $x(1),y(1)$ to the point defined by $x(2),y(2)$, specified in normalized figure units.

`annotation('arrow',x,y)` creates an arrow annotation object that extends from the point defined by $x(1),y(1)$ to the point defined by $x(2),y(2)$, specified in normalized figure units.

`annotation('doublearrow',x,y)` creates a two-headed annotation object that extends from the point defined by $x(1),y(1)$ to the point defined by $x(2),y(2)$, specified in normalized figure units.

`annotation('textarrow',x,y)` creates a `textarrow` annotation object that extends from the point defined by $x(1),y(1)$ to the point defined by $x(2),y(2)$, specified in normalized figure units. The tail end of the arrow is attached to an editable text box.

`annotation('textbox',[x y w h])` creates an editable text box annotation with its lower left corner at the point x,y , a width w , and a height h , specified in normalized figure units. Specify x, y, w , and h in a single vector.

To type in the text box, enable plot edit mode (`plotedit`) and double-click within the box.

`annotation('ellipse',[x y w h])` creates an ellipse annotation with the lower left corner of the bounding rectangle at the point x,y , a width w , and a height h , specified in normalized figure units. Specify x, y, w , and h in a single vector.

`annotation('rectangle',[x y w h])` creates a rectangle annotation with the lower left corner of the rectangle at the point x,y , a width w , and a height h , specified in normalized figure units. Specify x, y, w , and h in a single vector.

`annotation(figure_handle,...)` creates the annotation in the specified figure.

`annotation(...,'PropertyName',PropertyValue,...)` creates the annotation and sets the specified properties to the specified values.

`anno_obj_handle = annotation(...)` returns the handle to the “Annotation Objects”.

Examples

Add Text Box to Graph

Annotate the graph with a text box. Specify the text box location in normalized figure coordinates.

annotation

```
figure; % new figure window
plot(1:10);
annotation('textbox', [0.2,0.4,0.1,0.1],...
           'String', 'Straight Line Plot 1 to 10');
```

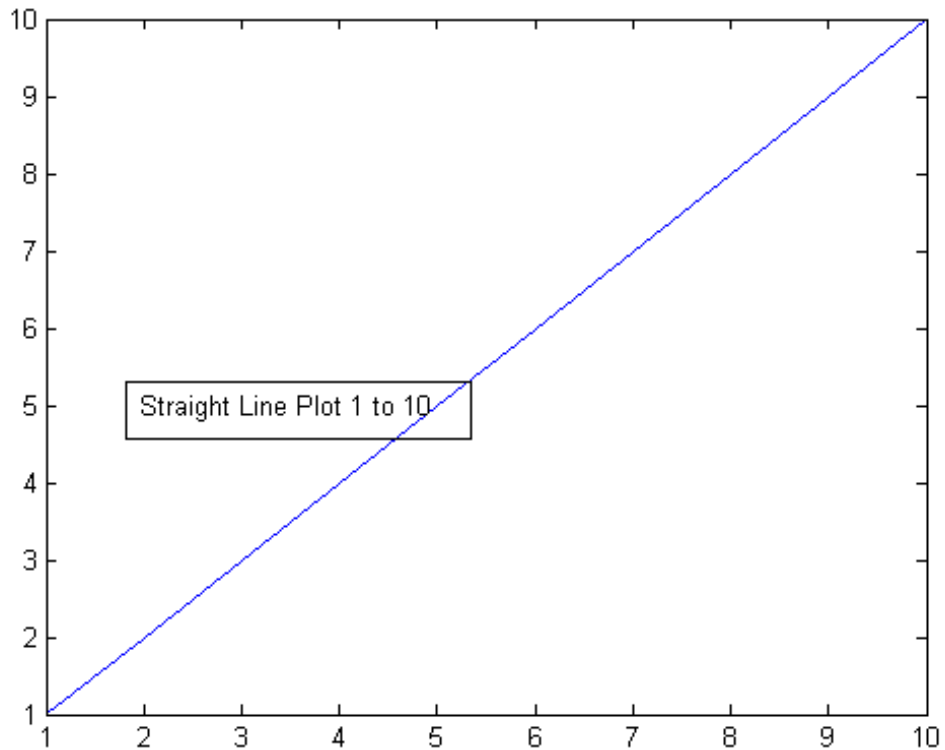

Add Text Box with Multiple Lines to Graph

Insert multiple lines in a text box by creating a cell array of strings. Each element is used as a separate line.

```
figure
plot(1:10);
str = {'Straight Line', 'Plot of 1 to 10'};
annotation('textbox', [0.2,0.4,0.1,0.1],...
           'String', str);
```

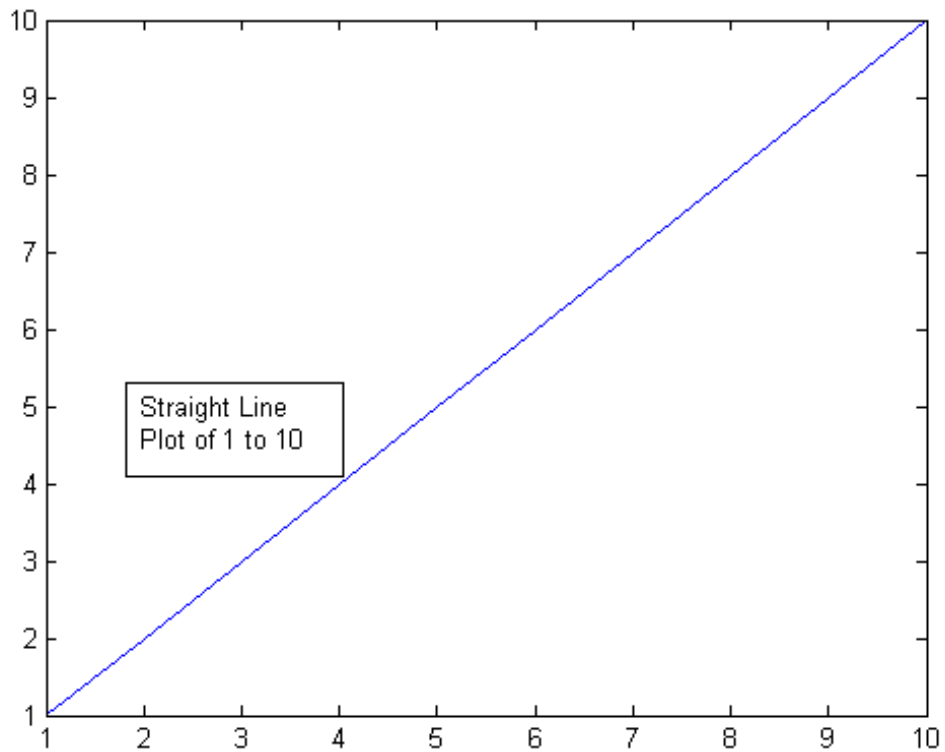

Add Text Arrow to Graph

Add a text arrow to the graph. Define the text arrow to start from (0.3,0.6) and extend to (0.5,0.5) in normalized figure coordinates.

annotation

```
figure
plot(1:10);
annotation('textarrow', [0.3,0.5], [0.6,0.5],...
          'String' , 'Straight Line');
```

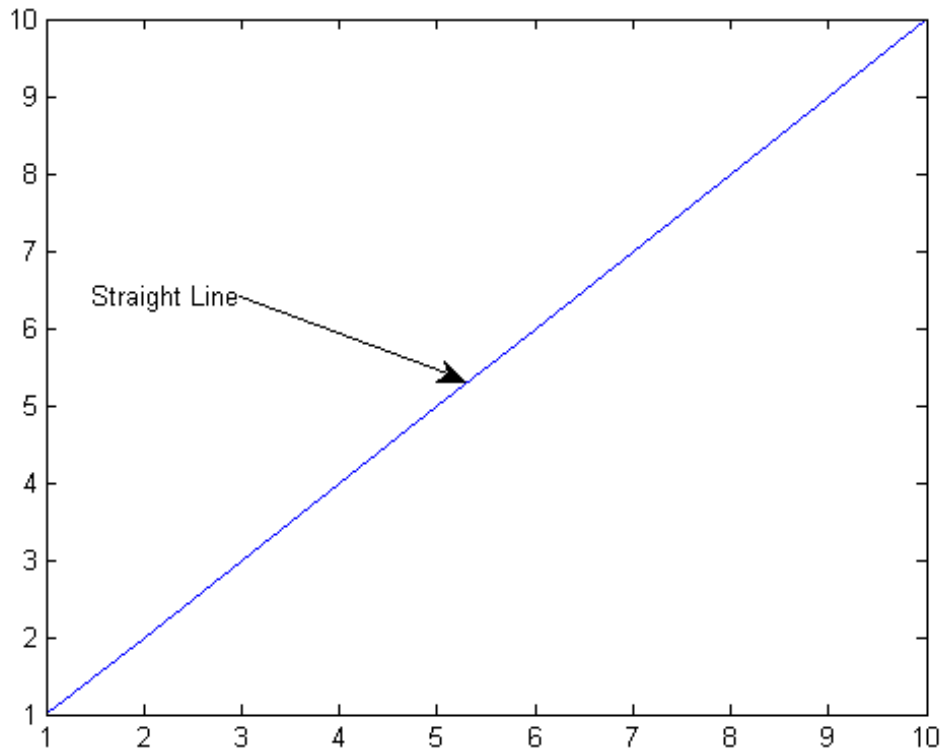

Adding Annotations Interactively

It is often convenient to place annotations interactively. For details, see “Customize Graph Using Plot Tools”.

See Also

[Annotation Arrow Properties](#) | [Annotation Doublearrow Properties](#) | [Annotation Ellipse Properties](#) | [Annotation Line Properties](#) | [Annotation Rectangle Properties](#) | [Annotation Textarrow Properties](#) | [Annotation Textbox Properties](#)

How To

- [“How to Annotate Graphs”](#)
- [“Annotation Objects”](#)

Annotation Arrow Properties

Purpose Define annotation arrow properties

Modifying Properties You can set and query annotation object properties using the `set` and `get` functions and the Property Editor (displayed with the `propertyeditor` command).

Use the `annotation` function to create annotation objects and obtain their handles. For an example of its use, see “Annotation Objects” in the MATLAB Graphics documentation.

Annotation Arrow Property Descriptions

Color
ColorSpec

Color of the object. A three-element RGB vector or one of the MATLAB predefined names, specifying the object’s color. The default value is `[0 0 0]` (black).

See the `ColorSpec` reference page for more information on specifying color. See “Adding Arrows and Lines to Graphs”.

HeadLength
size in points















Length of the arrowhead. Specify this property in points. 1 point = $\frac{1}{72}$ inch. The default value is 10. See also `HeadWidth`.

HeadStyle
string

Style of arrowhead. Specify this property as one of the strings from the following table.

Annotation Arrow Properties

Arrow Head Style Table

Head Style String	Head	Head Style String	Head
none		star4	
plain		rectangle	
ellipse		diamond	
vback1		rose	
vback2 (Default)		hypocycloid	
vback3		astroid	
cback1		deltoid	
cback2			
cback3			

HeadWidth
size in points

Width of arrowhead. Specify in points. 1 point = $\frac{1}{72}$ inch. The default value is 10. See also HeadLength.

Annotation Arrow Properties

LineStyle

{-} | -- | : | -. | none

Style of arrow stem.

Line Style Specifiers Table

Specifier	Line Style
'-'	Solid line (default)
'--'	Dashed line
':'	Dotted line
'-.'	Dash-dot line
'none'	No line

LineWidth

size in points

Width of arrow stem. Specify in points. 1 point = $\frac{1}{72}$ inch. The default is 0.5 points.

Position

four-element vector [x, y, width, height]

Size and location of the object. Specify the lower left corner of the object with the first two elements of the vector defining the point x, y in units normalized to the figure (when Units property is normalized). width and height specify the object's dx and dy , respectively, in units normalized to the figure. The default value is [0.3 0.3 0.1 0.1].

Units

{normalized} | inches | centimeters | characters |
points | pixels

Position units. MATLAB uses this property to determine the units used by the `Position` property. All positions are measured from the lower left corner of the figure window.

- `normalized` — Interpret `Position` as a fraction of the width and height of the parent axes. When you resize the axes, MATLAB modifies the size of the object accordingly.
- `pixels`, `inches`, `centimeters`, and `points` — Absolute units. 1 point = $1/72$ inch.
- `characters` — Based on the size of characters in the default system font. The width of one characters unit is the width of the letter x, and the height of one characters unit is the distance between the baselines of two lines of text.

X

vector [X_{begin} X_{end}]

x-coordinates of beginning and ending points for line. A vector of x-axis (horizontal) values specifying the beginning and ending points of the line, units normalized to the figure. The default value is [0.3 0.4].

Y

vector [Y_{begin} Y_{end}]

y-coordinates of beginning and ending points for line. A vector of y-axis (vertical) values specifying the beginning and ending points of the line, units normalized to the figure. The default value is [0.3 0.4].

See Also

annotation

How To

- “Annotation Objects”
- “Adding Arrows and Lines to Graphs”

Annotation Doublearrow Properties

Purpose Define annotation doublearrow properties

Modifying Properties You can set and query annotation object properties using the `set` and `get` functions and the Property Editor (displayed with the `propertyeditor` command).

Use the `annotation` function to create annotation objects and obtain their handles. For an example of its use, see “Annotation Objects” in the MATLAB Graphics documentation.

Annotation Doublearrow Property Descriptions This section provides a description of properties. Curly braces { } enclose default values.

Color
ColorSpec

Color of the object. A three-element RGB vector or one of the MATLAB predefined names, specifying the object’s color. The default value is [0 0 0] (black).

See the ColorSpec reference page for more information on specifying color. See “Adding Arrows and Lines to Graphs”.

Head1Length
size in points

Length of first arrowhead. Specify in points. 1 point = $1/72$ inch. The default value is 10.

The first arrowhead is located at the end defined by the point `x(1)`, `y(1)`.

See also the `Head1Style`, `Head1Width`, `X` and `Y` properties.

Head2Length
size in points

Annotation Doublearrow Properties

Length of second arrowhead. Specify in points. 1 point = $\frac{1}{72}$ inch. The default value is 10.











The first arrowhead is located at the end defined by the point $x(\text{end})$, $y(\text{end})$.

See also the `Head1Style`, `Head1Width`, `X` and `Y` properties.





`Head1Style`
string

Style of first arrowhead. Specify this property as one of the strings from the following table.

Arrow Head Style Table

Head Style String	Head	Head Style String	Head
none		star4	
plain		rectangle	
ellipse		diamond	
vback1		rose	
vback2 (Default)		hypocycloid	
vback3		astroid	

Annotation Doublearrow Properties

Head Style String	Head	Head Style String	Head
cback1		deltoid	
cback2			
cback3			

See also Head1Width, Head1Length, and LineWidth.

Head2Style
string

Style of second arrowhead. Specify this property as one of the strings shown in the table for the Head1Style property.

See also Head2Width, Head2Length, LineWidth.

Head1Width
size in points

Width of first arrowhead. Specify in points. 1 point = $\frac{1}{72}$ inch.
See also Head1Length.

Head2Width
size in points

Width of second arrowhead. Specify in points. 1 point = $\frac{1}{72}$ inch.
See also Head2Length.

LineStyle
{-} | -- | : | -. | none

Style of arrow stem.

Annotation Doublearrow Properties

Line Style Specifiers Table

Specifier	Line Style
'-'	Solid line (default)
'--'	Dashed line
':'	Dotted line
'-.'	Dash-dot line
'none'	No line

See also `Head1Style`, `Head1Length`, and `LineWidth`.

`LineWidth`

size in points

Width of arrow stem. Specify in points. 1 point = $1/72$ inch. The default is 0.5 points.

`Position`

four-element vector [`x`, `y`, `width`, `height`]

Size and location of the object. Specify the lower left corner of the object with the first two elements of the vector defining the point x , y in units normalized to the figure (when `Units` property is normalized). `width` and `height` specify the object's dx and dy , respectively, in units normalized to the figure. The default value is [0.3 0.3 0.1 0.1].

`Units`

{normalized} | inches | centimeters | characters |
points | pixels

Position units. MATLAB uses this property to determine the units used by the `Position` property. All positions are measured from the lower left corner of the figure window.

Annotation Doublearrow Properties

- **normalized** — Interpret `Position` as a fraction of the width and height of the parent axes. When you resize the axes, MATLAB modifies the size of the object accordingly.
- **pixels, inches, centimeters, and points** — Absolute units. 1 point = $1/72$ inch.
- **characters** — Based on the size of characters in the default system font. The width of one characters unit is the width of the letter x, and the height of one characters unit is the distance between the baselines of two lines of text.

X

vector [X_{begin} X_{end}]

x-coordinates of beginning and ending points for line. A vector of *x-axis* (horizontal) values specifying the beginning and ending points of the line, units normalized to the figure. The default value is [0.3 0.4].

Y

vector [Y_{begin} Y_{end}]

y-coordinates of beginning and ending points for line. A vector of *y-axis* (vertical) values specifying the beginning and ending points of the line, units normalized to the figure. The default value is [0.3 0.4].

See Also

annotation

How To

- “Annotation Objects”
- “Adding Arrows and Lines to Graphs”

Purpose

Define annotation ellipse properties

Modifying Properties

You can set and query annotation object properties using the `set` and `get` functions and the Property Editor (displayed with the `propertyeditor` command).

Use the `annotation` function to create annotation objects and obtain their handles. For an example of its use, see “Annotation Objects” in the MATLAB Graphics documentation.

Annotation Ellipse Property Descriptions

This section provides a description of properties. Curly braces { } enclose default values.

`EdgeColor`
ColorSpec | none

Edge color of object. A three-element RGB vector or one of the MATLAB predefined names, specifying the edge color. The default value is [0 0 0] (black).

See the `ColorSpec` reference page for more information on specifying color.

`FaceColor`
{flat} | none | ColorSpec

Color of filled areas.

- `ColorSpec` — A three-element RGB vector or one of the MATLAB predefined names, specifying a single color for all filled areas.
- `none` — Do not draw faces. Note that MATLAB draws `EdgeColor` independently of `FaceColor`.
- `flat` — The object uses the figure `colormap` to determine the color of the filled areas.

`LineStyle`
{-} | -- | : | -. | none

Annotation Ellipse Properties

Line style of ellipse.

Line Style Specifiers Table

Specifier	Line Style
'-'	Solid line (default)
'--'	Dashed line
'.'	Dotted line
'-.'	Dash-dot line
'none'	No line

LineWidth

size in points

Width of linear objects and edges of filled areas. Specify in points. 1 point = $\frac{1}{72}$ inch. The default is 0.5 points.

Position

four-element vector [x, y, width, height]

Size and location of the object. Specify the lower left corner of the object with the first two elements of the vector defining the point x, y in units normalized to the figure (when Units property is normalized). width and height specify the object's dx and dy , respectively, in units normalized to the figure. The default value is [0.3 0.3 0.1 0.1].

Units

{normalized} | inches | centimeters | characters |
points | pixels

Position units. MATLAB uses this property to determine the units used by the Position property. All positions are measured from the lower left corner of the figure window.

- **normalized** — Interpret **Position** as a fraction of the width and height of the parent axes. When you resize the axes, MATLAB modifies the size of the object accordingly.
- **pixels, inches, centimeters, and points** — Absolute units. 1 point = $\frac{1}{72}$ inch.
- **characters** — Based on the size of characters in the default system font. The width of one **characters** unit is the width of the letter x, and the height of one **characters** unit is the distance between the baselines of two lines of text.

See Also

annotation

How To

- “Annotation Objects”
- “How to Annotate Graphs”

Annotation Line Properties

Purpose Define annotation line properties

Modifying Properties You can set and query annotation object properties using the `set` and `get` functions and the Property Editor (displayed with the `propertyeditor` command).

Use the `annotation` function to create annotation objects and obtain their handles. For an example of its use, see “Annotation Objects” in the MATLAB Graphics documentation.

Annotation Line Property Descriptions This section provides a description of properties. Curly braces { } enclose default values.

Color
ColorSpec

Color of the object. A three-element RGB vector or one of the MATLAB predefined names, specifying the object’s color. The default value is [0 0 0] (black).

See the ColorSpec reference page for more information on specifying color. See “Adding Arrows and Lines to Graphs”.

LineStyle
{-} | -- | : | -. | none

Line style of annotation line object.

Line Style Specifiers Table

Specifier	Line Style
'-'	Solid line (default)
'--'	Dashed line
':'	Dotted line

Annotation Line Properties

Specifier	Line Style
'-.'	Dash-dot line
'none'	No line

LineWidth

size in points

Width of linear objects and edges of filled areas. Specify in points. 1 point = $1/72$ inch. The default is 0.5 points.

Position

four-element vector [x, y, width, height]

Size and location of the object. Specify the lower left corner of the object with the first two elements of the vector defining the point x, y in units normalized to the figure (when `Units` property is `normalized`). `width` and `height` specify the object's dx and dy , respectively, in units normalized to the figure. The default value is [0.3 0.3 0.1 0.1].

Units

{normalized} | inches | centimeters | characters |
points | pixels

Position units. MATLAB uses this property to determine the units used by the `Position` property. All positions are measured from the lower left corner of the figure window.

- `normalized` — Interpret `Position` as a fraction of the width and height of the parent axes. When you resize the axes, MATLAB modifies the size of the object accordingly.
- `pixels`, `inches`, `centimeters`, and `points` — Absolute units. 1 point = $1/72$ inch.
- `characters` — Based on the size of characters in the default system font. The width of one characters unit is the width

Annotation Line Properties

of the letter x, and the height of one characters unit is the distance between the baselines of two lines of text.

X

vector $[X_{\text{begin}} X_{\text{end}}]$

x-coordinates of beginning and ending points for line. A vector of *x-axis* (horizontal) values specifying the beginning and ending points of the line, units normalized to the figure. The default value is $[0.3 0.4]$.

Y

vector $[Y_{\text{begin}} Y_{\text{end}}]$

y-coordinates of beginning and ending points for line. A vector of *y-axis* (vertical) values specifying the beginning and ending points of the line, units normalized to the figure. The default value is $[0.3 0.4]$.

See Also

annotation

How To

- “Annotation Objects”
- “Adding Arrows and Lines to Graphs”

Purpose

Define annotation rectangle properties

Modifying Properties

You can set and query annotation object properties using the `set` and `get` functions and the Property Editor (displayed with the `propertyeditor` command).

Use the `annotation` function to create annotation objects and obtain their handles. For an example of its use, see “Annotation Objects” in the MATLAB Graphics documentation.

Annotation Rectangle Property Descriptions

This section provides a description of properties. Curly braces { } enclose default values.

EdgeColor
ColorSpec | none

Edge color of object. A three-element RGB vector or one of the MATLAB predefined names, specifying the edge color. The default value is [0 0 0] (black).

See the ColorSpec reference page for more information on specifying color.

FaceAlpha
Scalar alpha value in range [0 1]

Transparency of object background. Defines the degree to which the object’s background color is transparent. A value of 1 (the default) makes the background opaque, a value of 0 makes the background completely transparent (that is, invisible). The default value is 1.

FaceColor
{flat} | none | ColorSpec

Color of filled areas.

Annotation Rectangle Properties

- **ColorSpec** — A three-element RGB vector or one of the MATLAB predefined names, specifying a single color for all filled areas.
- **none** — Do not draw faces. Note that MATLAB draws `EdgeColor` independently of `FaceColor`.
- **flat** — The object uses the figure colormap to determine the color of the filled areas.

LineStyle

{-} | -- | : | -. | none

Line style of annotation rectangle object.

Line Style Specifiers Table

Specifier	Line Style
'-'	Solid line (default)
'--'	Dashed line
':'	Dotted line
'-.'	Dash-dot line
'none'	No line

LineWidth

size in points

Width of linear objects and edges of filled areas. Specify in points. 1 point = $1/72$ inch. The default is 0.5 points.

Position

four-element vector [x, y, width, height]

Size and location of the object. Specify the lower left corner of the object with the first two elements of the vector defining the point x, y in units normalized to the figure (when `Units` property is normalized). $width$ and $height$ specify the object's dx and dy ,

Annotation Rectangle Properties

respectively, in units normalized to the figure. The default value is [0.3 0.3 0.1 0.1].

Units

{normalized} | inches | centimeters | characters | points | pixels

Position units. MATLAB uses this property to determine the units used by the `Position` property. All positions are measured from the lower left corner of the figure window.

- `normalized` — Interpret `Position` as a fraction of the width and height of the parent axes. When you resize the axes, MATLAB modifies the size of the object accordingly.
- `pixels`, `inches`, `centimeters`, and `points` — Absolute units. 1 point = $\frac{1}{72}$ inch.
- `characters` — Based on the size of characters in the default system font. The width of one `characters` unit is the width of the letter x, and the height of one `characters` unit is the distance between the baselines of two lines of text.

See Also

`annotation`

Annotation Textarrow Properties

Purpose

Define annotation textarrow properties

Modifying Properties

You can set and query annotation object properties using the `set` and `get` functions and the Property Editor (displayed with the `propertyeditor` command).

Use the `annotation` function to create annotation objects and obtain their handles. For an example of its use, see “Annotation Objects” in the MATLAB Graphics documentation.

Annotation Textarrow Property Descriptions

This section provides a description of properties. Curly braces { } enclose default values.

Color

ColorSpec

Color of the arrow, text and text border. A three-element RGB vector or one of the MATLAB predefined names, specifying the color of the arrow, the color of the text (`TextColor` property), and the rectangle enclosing the text (`TextEdgeColor` property). The default value is `[0 0 0]` (black).

Setting the `Color` property also sets the `TextColor` and `TextEdgeColor` properties to the same color. However, if the value of the `TextEdgeColor` is `none`, it remains `none` and the text box is not displayed. You can set `TextColor` or `TextEdgeColor` independently without affecting other properties.

For example, if you want to create a textarrow with a red arrow and black text in a black box, you must:

- 1 Set the `Color` property to red — `set(h, 'Color', 'r')`
- 2 Set the `TextColor` to black — `set(h, 'TextColor', 'k')`
- 3 Set the `TextEdgeColor` to black. —
`set(h, 'TextEdgeColor', 'k')`

Annotation Textarrow Properties

If you do not want display the text box, set the `TextEdgeColor` to `none`.

See the `ColorSpec` reference page for more information on specifying color.

FontAngle

`{normal} | italic | oblique`

Character slant. MATLAB uses this property to select a font from those available on your particular system. Generally, setting this property to `italic` or `oblique` selects a slanted font.

FontName

string

Font family. A string specifying the name of the font to use for the text. To display and print properly, this font must be supported on your system. The default font is Helvetica.

FontSize

size in points

Approximate size of text characters. Specify in points. 1 point = $\frac{1}{72}$ inch. The default size is 10.

FontUnits

`{points} | normalized | inches | centimeters | pixels`

Font size units. MATLAB uses this property to determine the units used by the `FontSize` property. Normalized units interpret `FontSize` as a fraction of the height of the parent axes. When you resize the axes, MATLAB modifies the screen `FontSize` accordingly. `pixels`, `inches`, `centimeters`, and `points` are absolute units. 1 point = $\frac{1}{72}$ inch.

FontWeight

`{normal} | bold | light | demi`

Annotation Textarrow Properties

Weight of text characters. MATLAB uses this property to select a font from those available on your system. Generally, setting this property to bold or demi causes MATLAB to use a bold font.











HeadLength
size in points

Length of the arrowhead. Specify this property in points. 1 point = $\frac{1}{72}$ inch. The default value is 10. See also HeadWidth.





HeadStyle
string

Style of arrowhead. Specify this property as one of the strings from the following table.

Arrow Head Style Table

Head Style String	Head	Head Style String	Head
none		star4	
plain		rectangle	
ellipse		diamond	
vback1		rose	
vback2 (Default)		hypocycloid	
vback3		astroid	

Annotation Textarrow Properties

Head Style String	Head	Head Style String	Head
cback1		deltoid	
cback2			
cback3			

HeadWidth

size in points

Width of arrowhead. Specify in points. 1 point = $1/72$ inch. The default value is 10. See also HeadLength.

HorizontalAlignment

left | center | {right}

Horizontal alignment of text. Specifies the horizontal justification of the text string. This property determines where MATLAB places the string horizontally with regard to the points specified by the Position property.

Interpreter

latex | {tex} | none

Interpret TeX instructions. This property controls whether MATLAB interprets certain characters in the String property as TeX instructions (default) or displays all characters literally. The options are:

- latex — Supports a basic subset of the LaTeX markup language.
- tex — Supports a subset of plain TeX markup language. See the String property for a list of supported TeX instructions.

Annotation Textarrow Properties

- none — Displays literal characters.

LineStyle

{-} | -- | : | -. | none

Line style of arrow stem.

Line Style Specifiers Table

Specifier	Line Style
'-'	Solid line (default)
'--'	Dashed line
':'	Dotted line
'-.'	Dash-dot line
'none'	No line

LineWidth

size in points

Width of arrow stem. Specify in points 1 point = $1/72$ inch. The default is 0.5 points.

Position

four-element vector [x, y, width, height]

Size and location of the object. Specify the lower left corner of the object with the first two elements of the vector defining the point x, y in units normalized to the figure (when Units property is normalized). width and height specify the object's dx and dy , respectively, in units normalized to the figure. The default value is [0.3 0.3 0.1 0.1].

String

string

Annotation Textarrow Properties

Text string. Specify this property as a quoted string for single-line strings, or as a cell array of strings, or a padded string matrix for multiline strings. MATLAB displays this string at the specified location. Vertical slash characters are not interpreted as line breaks in text strings, and are drawn as part of the text string. See Mathematical Symbols, Greek Letters, and TeX Characters for an example.

Note The words `default`, `factory`, and `remove` are reserved words that will not appear in a figure when quoted as a normal string. In order to display any of these words individually, type `'\reserved_word'` instead of `'reserved_word'`.

When the text Interpreter property is `tex` (the default), you can use a subset of TeX commands embedded in the string to produce special characters such as Greek letters and mathematical symbols. This table lists these characters and the character sequences used to define them.

Character Sequence	Symbol	Character Sequence	Symbol	Character Sequence	Symbol
<code>\alpha</code>	α	<code>\upsilon</code>	υ	<code>\sim</code>	\sim
<code>\angle</code>	\angle	<code>\phi</code>	Φ	<code>\leq</code>	\leq
<code>\ast</code>	$*$	<code>\chi</code>	χ	<code>\infty</code>	∞
<code>\beta</code>	β	<code>\psi</code>	ψ	<code>\clubsuit</code>	\clubsuit
<code>\gamma</code>	γ	<code>\omega</code>	ω	<code>\diamondsuit</code>	\diamondsuit
<code>\delta</code>	δ	<code>\Gamma</code>	Γ	<code>\heartsuit</code>	\heartsuit
<code>\epsilon</code>	ϵ	<code>\Delta</code>	Δ	<code>\spadesuit</code>	\spadesuit
<code>\zeta</code>	ζ	<code>\Theta</code>	Θ	<code>\leftrightarrow</code>	\leftrightarrow

Annotation Textarrow Properties

Character Sequence	Symbol	Character Sequence	Symbol	Character Sequence	Symbol
<code>\eta</code>	η	<code>\Lambda</code>	Λ	<code>\leftarrow</code>	\leftarrow
<code>\theta</code>	Θ	<code>\Xi</code>	Ξ	<code>\Leftarrow</code>	\Leftarrow
<code>\vartheta</code>		<code>\Pi</code>	Π	<code>\uparrow</code>	\uparrow
<code>\iota</code>	ι	<code>\Sigma</code>	Σ	<code>\rightarrow</code>	\rightarrow
<code>\kappa</code>	κ	<code>\Upsilon</code>		<code>\Rightarrow</code>	\Rightarrow
<code>\lambda</code>	λ	<code>\Phi</code>	Φ	<code>\downarrow</code>	\downarrow
<code>\mu</code>	μ	<code>\Psi</code>	Ψ	<code>\circ</code>	\circ
<code>\nu</code>	ν	<code>\Omega</code>	Ω	<code>\pm</code>	\pm
<code>\xi</code>	ξ	<code>\forall</code>	\forall	<code>\geq</code>	\geq
<code>\pi</code>	π	<code>\exists</code>	\exists	<code>\propto</code>	\propto
<code>\rho</code>	ρ	<code>\ni</code>	\ni	<code>\partial</code>	∂
<code>\sigma</code>	σ	<code>\cong</code>	\cong	<code>\bullet</code>	\bullet
<code>\varsigma</code>	ς	<code>\approx</code>	\approx	<code>\div</code>	\div
<code>\tau</code>	τ	<code>\Re</code>	\Re	<code>\neq</code>	\neq
<code>\equiv</code>	\equiv	<code>\oplus</code>	\oplus	<code>\aleph</code>	
<code>\Im</code>	\Im	<code>\cup</code>	\cup	<code>\wp</code>	\wp
<code>\otimes</code>	\otimes	<code>\subseteq</code>	\subseteq	<code>\oslash</code>	\oslash
<code>\cap</code>	\cap	<code>\in</code>		<code>\supseteq</code>	\supseteq
<code>\supset</code>	\supset	<code>\lceil</code>	\lceil	<code>\subset</code>	\subset
<code>\int</code>	\int	<code>\cdot</code>	\cdot	<code>\circ</code>	\circ
<code>\rfloor</code>	\rfloor	<code>\neg</code>	\neg	<code>\nabla</code>	∇

Annotation Textarrow Properties

Character Sequence	Symbol	Character Sequence	Symbol	Character Sequence	Symbol
<code>\lfloor</code>	⌊	<code>\times</code>	x	<code>\ldots</code>	...
<code>\perp</code>	⊥	<code>\surd</code>	√	<code>\prime</code>	′
<code>\wedge</code>	∧	<code>\varpi</code>	ϖ	<code>\0</code>	∅
<code>\rceil</code>	⌈	<code>\rangle</code>	⟩	<code>\mid</code>	
<code>\vee</code>	∨			<code>\copyright</code>	©
<code>\langle</code>	⟨				

You can also specify stream modifiers that control font type and color. The first four modifiers are mutually exclusive. However, you can use `\fontname` in combination with one of the other modifiers.

`TextBackgroundColor`
`ColorSpec | {none}`

Color of text background rectangle. A three-element RGB vector or one of the MATLAB predefined names, specifying the arrow color.

See the `ColorSpec` reference page for more information on specifying color.

`TextColor`
`ColorSpec`

Color of text. A three-element RGB vector or one of the MATLAB predefined names, specifying the arrow color. The default value is `[0 0 0]` (black).

Annotation Textarrow Properties

See the `ColorSpec` reference page for more information on specifying color. Setting the `Color` property also sets this property.

`TextEdgeColor`
ColorSpec | {none}

Color of edge of text rectangle. A three-element RGB vector or one of the MATLAB predefined names, specifying the color of the rectangle that encloses the text.

See the `ColorSpec` reference page for more information on specifying color. Setting the `Color` property also sets this property.

`TextLineWidth`
width in points

Width of text rectangle edge. Specify in points. 1 point = $\frac{1}{72}$ inch. The default value is 0.5.

`TextMargin`
size in pixels

Space around text. A value in pixels that defines the space around the text string, but within the rectangle. Default value is 5 pixels.

`TextRotation`
rotation angle in degrees

Text orientation. Determines the orientation of the text string. Specify values of rotation in degrees (positive angles cause counterclockwise rotation). Angles are absolute and not relative to previous rotations; a rotation of 0 degrees is always horizontal. Default is 0.

`Units`
{normalized} | inches | centimeters | characters |
points | pixels

Position units. MATLAB uses this property to determine the units used by the `Position` property. All positions are measured from the lower left corner of the figure window.

- `normalized` — Interpret `Position` as a fraction of the width and height of the parent axes. When you resize the axes, MATLAB modifies the size of the object accordingly.
- `pixels`, `inches`, `centimeters`, and `points` — Absolute units. 1 point = $1/72$ inch.
- `characters` — Based on the size of characters in the default system font. The width of one characters unit is the width of the letter x, and the height of one characters unit is the distance between the baselines of two lines of text.

VerticalAlignment

`top` | `cap` | `{middle}` | `baseline` | `bottom`

Vertical alignment of text. Specifies the vertical justification of the text string. It determines where MATLAB places the string vertically with regard to the points specified by the `Position` property.

Note that `top` and `cap` both place the text at the top, while `baseline` and `bottom` both align the text on the bottom.

X

vector $[X_{\text{begin}} \ X_{\text{end}}]$

x-coordinates of beginning and ending points for line. A vector of *x*-axis (horizontal) values specifying the beginning and ending points of the line, units normalized to the figure. The default value is `[0.3 0.4]`.

Y

vector $[Y_{\text{begin}} \ Y_{\text{end}}]$

Annotation Textarrow Properties

y-coordinates of beginning and ending points for line. A vector of *y*-axis (vertical) values specifying the beginning and ending points of the line, units normalized to the figure. The default value is [0.3 0.4].

See Also

annotation

Purpose

Define annotation textbox properties

Modifying Properties

You can set and query annotation object properties using the `set` and `get` functions and the Property Editor (displayed with the `propertyeditor` command).

Use the `annotation` function to create annotation objects and obtain their handles. For an example of its use, see “Annotation Objects” in the MATLAB Graphics documentation.

Annotation Textbox Property Descriptions

This section provides a description of properties. Curly braces { } enclose default values.

`BackgroundColor`
`ColorSpec` | {none}

Color of text background rectangle. A three-element RGB vector or one of the MATLAB predefined names, specifying the rectangle background color. The default value is none.

See the `ColorSpec` reference page for more information on specifying color.

`Color`
`ColorSpec`

Text color. A three-element RGB vector or one of the predefined names, specifying the text color. The default value is black. See `ColorSpec` for more information on specifying color.

`EdgeColor`
`ColorSpec` | {none}

Color of edge of text rectangle. A three-element RGB vector or one of the MATLAB predefined names, specifying the color of the rectangle that encloses the text.

Annotation Textbox Properties

See the `ColorSpec` reference page for more information on specifying color. Setting the `Color` property also sets this property.

FaceAlpha

Scalar alpha value in range [0 1]

Transparency of object background. Defines the degree to which the object's background color is transparent. A value of 1 (the default) makes the background opaque, a value of 0 makes the background completely transparent (that is, invisible). The default value is 1.

FitBoxToText

{on} | off

Automatically adjust text box width and height to fit text. When this property is on (the default), MATLAB automatically resizes textboxes to fit the *x*-extents and *y*-extents of the text strings they contain. When it is off, text strings are wrapped to fit the width of their textboxes, which can cause them to extend below the bottom of the box.

If you resize a textbox in plot edit mode or change the width or height of its `Position` property directly, MATLAB sets the object's `FitBoxToText` property to off. You can toggle this property with `set`, with the Property Inspector, or in plot edit mode via the object's context menu.

FitHeightToText

on | off

Automatically adjust text box width and height to fit text. MATLAB automatically wraps text strings to fit the width of the text box. However, if the text string is long enough, it can extend beyond the bottom of the text box.

Annotation Textbox Properties

Note The property is obsolete. To control line wrapping behavior in textboxes, use `FitBoxToText` instead.

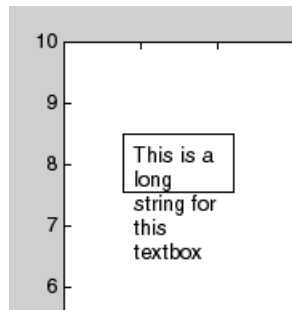

When you set this mode to on, MATLAB automatically adjusts the height of the text box to accommodate the string, doing so as you create or edit the string.

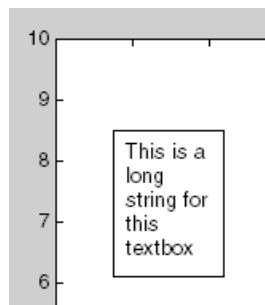

The fit-size-to-text behavior turns off if you resize the text box programmatically or manually in plot edit mode.

Annotation Textbox Properties

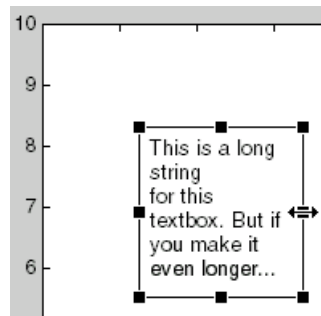

However, if you resize the text box from any other handles, the position you set is honored without regard to how the text fits the box.

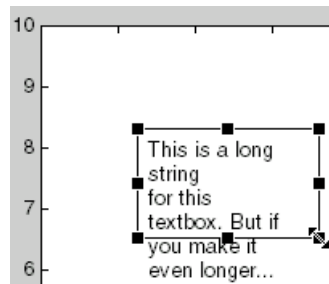

FontAngle

{normal} | italic | oblique

Character slant. MATLAB uses this property to select a font from those available on your particular system. Generally, setting this property to italic or oblique selects a slanted font.

FontName

string

Font family. A string specifying the name of the font to use for the text. To display and print properly, this font must be supported on your system. The default font is Helvetica.

FontSize

size in points

Approximate size of text characters. Specify in points. 1 point = $\frac{1}{72}$ inch. The default size is 10.

FontUnits

{points} | normalized | inches | centimeters | pixels

Font size units. MATLAB uses this property to determine the units used by the FontSize property. Normalized units interpret FontSize as a fraction of the height of the parent axes. When you resize the axes, MATLAB modifies the screen FontSize accordingly. pixels, inches, centimeters, and points are absolute units. 1 point = $\frac{1}{72}$ inch.

FontWeight

{normal} | bold | light | demi

Weight of text characters. MATLAB uses this property to select a font from those available on your system. Generally, setting this property to bold or demi causes MATLAB to use a bold font.

HorizontalAlignment

{left} | center | right

Horizontal alignment of text. Specifies the horizontal justification of the text string within the textbox. It determines where MATLAB places the string horizontally with regard to the points specified by the Position property.

Interpreter

latex | {tex} | none

Interpret TeX instructions. This property controls whether MATLAB interprets certain characters in the String property as TeX instructions (default) or displays all characters literally. The options are:

Annotation Textbox Properties

- `latex` — Supports a basic subset of the LaTeX markup language.
- `tex` — Supports a subset of plain TeX markup language. See the `String` property for a list of supported TeX instructions.
- `none` — Displays literal characters.

LineStyle

{-} | -- | : | -. | none

Line style of annotation textbox object.

Line Style Specifiers Table

Specifier	Line Style
'-'	Solid line (default)
'--'	Dashed line
':'	Dotted line
'-.'	Dash-dot line
'none'	No line

LineWidth

size in points

Width of linear objects and edges of filled areas. Specify in points. 1 point = $1/72$ inch. The default is 0.5 points.

Margin

size in pixels

Space around text. A value in pixels that defines the space around the text string, but within the rectangle. Default value is 5 pixels.

Position

four-element vector [x, y, width, height]

Annotation Textbox Properties

Size and location of the object. Specify the lower left corner of the object with the first two elements of the vector defining the point x, y in units normalized to the figure (when `Units` property is normalized). `width` and `height` specify the object's dx and dy , respectively, in units normalized to the figure. The default value is `[0.3 0.3 0.1 0.1]`.

String
string

Text string. Specify this property as a quoted string for single-line strings, or as a cell array of strings, or a padded string matrix for multiline strings. MATLAB displays this string at the specified location. Vertical slash characters are not interpreted as line breaks in text strings, and are drawn as part of the text string. See *Mathematical Symbols*, *Greek Letters*, and *TeX Characters* for an example.

Note The words `default`, `factory`, and `remove` are reserved words that will not appear in a figure when quoted as a normal string. In order to display any of these words individually, type `'\reserved_word'` instead of `'reserved_word'`.

When the text `Interpreter` property is `tex` (the default), you can use a subset of TeX commands embedded in the string to produce special characters such as Greek letters and mathematical symbols. This table lists these characters and the character sequences used to define them.

Character Sequence	Symbol	Character Sequence	Symbol	Character Sequence	Symbol
<code>\alpha</code>	α	<code>\upsilon</code>	υ	<code>\sim</code>	\sim
<code>\angle</code>	\angle	<code>\phi</code>	Φ	<code>\leq</code>	\leq
<code>\ast</code>	$*$	<code>\chi</code>	χ	<code>\infty</code>	∞

Annotation Textbox Properties

Character Sequence	Symbol	Character Sequence	Symbol	Character Sequence	Symbol
<code>\beta</code>	β	<code>\psi</code>	ψ	<code>\clubsuit</code>	\clubsuit
<code>\gamma</code>	γ	<code>\omega</code>	ω	<code>\diamondsuit</code>	\diamondsuit
<code>\delta</code>	δ	<code>\Gamma</code>	Γ	<code>\heartsuit</code>	\heartsuit
<code>\epsilon</code>	ϵ	<code>\Delta</code>	Δ	<code>\spadesuit</code>	\spadesuit
<code>\zeta</code>	ζ	<code>\Theta</code>	Θ	<code>\leftrightharpoonright</code>	\leftrightarrow
<code>\eta</code>	η	<code>\Lambda</code>	Λ	<code>\leftarrow</code>	\leftarrow
<code>\theta</code>	θ	<code>\Xi</code>	Ξ	<code>\Leftarrow</code>	\Leftarrow
<code>\vartheta</code>		<code>\Pi</code>	Π	<code>\uparrow</code>	\uparrow
<code>\iota</code>	ι	<code>\Sigma</code>	Σ	<code>\rightarrow</code>	\rightarrow
<code>\kappa</code>	κ	<code>\Upsilon</code>		<code>\Rightarrow</code>	\Rightarrow
<code>\lambda</code>	λ	<code>\Phi</code>	Φ	<code>\downarrow</code>	\downarrow
<code>\mu</code>	μ	<code>\Psi</code>	Ψ	<code>\circ</code>	\circ
<code>\nu</code>	ν	<code>\Omega</code>	Ω	<code>\pm</code>	\pm
<code>\xi</code>	ξ	<code>\forall</code>	\forall	<code>\geq</code>	\geq
<code>\pi</code>	π	<code>\exists</code>	\exists	<code>\propto</code>	\propto
<code>\rho</code>	ρ	<code>\ni</code>	\ni	<code>\partial</code>	∂
<code>\sigma</code>	σ	<code>\cong</code>	\cong	<code>\bullet</code>	\bullet
<code>\varsigma</code>	ς	<code>\approx</code>	\approx	<code>\div</code>	\div
<code>\tau</code>	τ	<code>\Re</code>	\Re	<code>\neq</code>	\neq
<code>\equiv</code>	\equiv	<code>\oplus</code>	\oplus	<code>\aleph</code>	
<code>\Im</code>	\Im	<code>\cup</code>	\cup	<code>\wp</code>	\wp

Annotation Textbox Properties

Character Sequence	Symbol	Character Sequence	Symbol	Character Sequence	Symbol
<code>\otimes</code>	\otimes	<code>\subseteqq</code>	\subseteqq	<code>\oslash</code>	\oslash
<code>\cap</code>	\cap	<code>\in</code>	\in	<code>\supseteqq</code>	\supseteqq
<code>\supset</code>	\supset	<code>\lceil</code>	\lceil	<code>\subset</code>	\subset
<code>\int</code>	\int	<code>\cdot</code>	\cdot	<code>\o</code>	\circ
<code>\rfloor</code>	\rfloor	<code>\neg</code>	\neg	<code>\nabla</code>	∇
<code>\lfloor</code>	\lfloor	<code>\times</code>	\times	<code>\ldots</code>	\dots
<code>\perp</code>	\perp	<code>\surd</code>	\surd	<code>\prime</code>	\prime
<code>\wedge</code>	\wedge	<code>\varpi</code>	ϖ	<code>\0</code>	\emptyset
<code>\rceil</code>	\rceil	<code>\rangle</code>	\rangle	<code>\mid</code>	$ $
<code>\vee</code>	\vee			<code>\copyright</code>	\copyright
<code>\langle</code>	\langle				

You can also specify stream modifiers that control font type and color. The first four modifiers are mutually exclusive. However, you can use `\fontname` in combination with one of the other modifiers.

Units

`{normalized} | inches | centimeters | characters | points | pixels`

Position units. MATLAB uses this property to determine the units used by the `Position` property. All positions are measured from the lower left corner of the figure window.

Annotation Textbox Properties

- `normalized` — Interpret `Position` as a fraction of the width and height of the parent axes. When you resize the axes, MATLAB modifies the size of the object accordingly.
- `pixels`, `inches`, `centimeters`, and `points` — Absolute units. 1 point = $\frac{1}{72}$ inch.
- `characters` — Based on the size of characters in the default system font. The width of one `characters` unit is the width of the letter `x`, and the height of one `characters` unit is the distance between the baselines of two lines of text.

`VerticalAlignment`

`top` | `cap` | `{middle}` | `baseline` |
`bottom`

Vertical alignment of text. Specifies the vertical justification of the text string within the textbox. It determines where MATLAB places the string vertically with regard to the points specified by the `Position` property.

Note that `top` and `cap` both place the text at the top of the box, while `baseline` and `bottom` both align the text on the bottom.

See Also

`annotation`

Purpose	Most recent answer
Syntax	<code>ans</code>
Description	The MATLAB software creates the <code>ans</code> variable automatically when you specify no output argument.
Examples	<p>The statement</p> <pre>2+2</pre> <p>is the same as</p> <pre>ans = 2+2</pre>
See Also	<code>display</code>

any

Purpose Determine if any array elements are nonzero

Syntax
B = any(A)
B = any(A,dim)

Description B = any(A) tests along the first array dimension of A whose size does not equal 1, and determines if any element is a nonzero number or logical 1 (true). In practice, any is a natural extension of the logical OR operator.

- If A is a vector, then B = any(A) returns logical 1 (true) if any of the elements of A is a nonzero number or is logical 1, and returns logical 0 (false) if all the elements are zero.
- If A is a nonempty, nonvector matrix, then B = any(A) treats the columns of A as vectors, returning a row vector of logical 1s and 0s.
- If A is an empty 0-by-0 matrix, any(A) returns logical 0 (false).
- If A is a multidimensional array, any(A) acts along the first array dimension whose size does not equal 1 and returns an array of logical values. The size of this dimension becomes 1, while the sizes of all other dimensions remain the same.

B = any(A,dim) tests elements along dimension dim. The dim input is a positive integer scalar.

Input Arguments

A - Input array
scalar | vector | matrix | multidimensional array

Input array, specified as a scalar, vector, matrix, or multidimensional array. The any function ignores elements of A that are NaN (Not a Number).

Data Types
single | double | int8 | int16 | int32 | int64 | uint8 | uint16 | uint32 | uint64 | logical | char

Complex Number Support: Yes

dim - Dimension to operate along

positive integer scalar

Dimension to operate along, specified as a positive integer scalar. If no value is specified, the default is the first array dimension whose size does not equal 1.

Consider a two-dimensional input array, A:

- `any(A,1)` works on successive elements in the columns of A and returns a row vector of logical values.
- `any(A,2)` works on successive elements in the rows of A and returns a column vector of logical values.

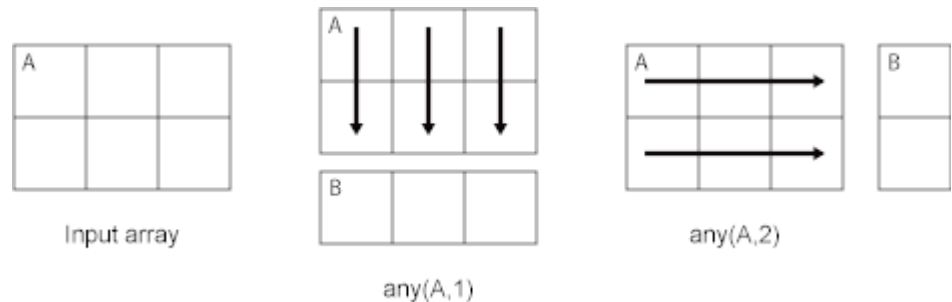
**Data Types**

double | single | int8 | int16 | int32 | int64 | uint8 |
uint16 | uint32 | uint64

Output Arguments**B - Logical array**

scalar | vector | matrix | multidimensional array

Logical array, returned as a scalar, vector, matrix, or multidimensional array. The dimension of A acted on by `any` has size 1 in B.

Examples**Test Matrix Columns**

Create a 3-by-3 matrix.

```
A = [0 0 3;0 0 3;0 0 3]
```

```
A =
```

```
    0    0    3
    0    0    3
    0    0    3
```

Test each column for nonzero elements.

```
B = any(A)
```

```
B =
```

```
    0    0    1
```

Reduce a Logical Vector to a Single Condition

Create a vector of decimal values and test which values are less than 0.5.

```
A = [0.53 0.67 0.01 0.38 0.07 0.42 0.69];
```

```
B = (A < 0.5)
```

```
B =
```

```
0  0  1  1  1  1  0
```

The output is a vector of logical values. The `any` function reduces such a vector of logical values to a single condition. In this case, `B = any(A < 0.5)` yields logical 1.

This makes `any` particularly useful in `if` statements.

```
if any(A < 0.5)
    %do something
else
    %do something else
end
```

The code is executed depending on a single condition, rather than a vector of possibly conflicting conditions.

Test Arrays of Any Dimension

Create a 3-by-7-by-5 multidimensional array and test to see if any of its elements are greater than 3.

```
A = rand(3,7,5) * 5;  
B = any(A(:) > 3)
```

```
B =
```

```
1
```

You can also test the array for elements that are less than zero.

```
B = any(A(:) < 0)
```

```
B =
```

```
0
```

The syntax `A(:)` turns the elements of `A` into a single column vector, so you can use this type of statement on an array of any size.

Test Matrix Rows

Create a 3-by-3 matrix.

```
A = [0 0 3;0 0 3;0 0 3]
```

```
A =
```

```
0     0     3  
0     0     3  
0     0     3
```

Test the rows of `A` for nonzero elements by specifying `dim = 2`.

any

```
B = any(A,2)
```

```
B =
```

```
    1  
    1  
    1
```

See Also

[all](#) | [colon \(:\)](#) | [or](#) | [prod](#) | [sum](#)

Concepts

- “Reduce Logical Arrays to Single Value”

Purpose Filled area 2-D plot

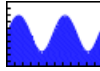

Syntax

```
area(Y)
area(X,Y)
area(...,basevalue)
area(...,'PropertyName',PropertyValue,...)
area(axes_handle,...)
h = area(...)
```

Description

An area graph displays elements in *Y* as one or more curves and fills the area beneath each curve. When *Y* is a matrix, the curves are stacked showing the relative contribution of each row element to the total height of the curve at each *x* interval.

`area(Y)` plots the vector *Y* or plots each column in matrix *Y* as a separate curve and stacks the curves. The *x*-axis automatically scales to `1:size(Y,1)`.

`area(X,Y)` For vectors *X* and *Y*, `area(X,Y)` is the same as `plot(X,Y)` except that the area between 0 and *Y* is filled. When *Y* is a matrix, `area(X,Y)` plots the columns of *Y* as filled areas. For each *X*, the net result is the sum of corresponding values from the rows of *Y*.

If *X* is a vector, `length(X)` must equal `length(Y)`. If *X* is a matrix, `size(X)` must equal `size(Y)`.

`area(...,basevalue)` specifies the base value for the area fill. The default basevalue is 0. See the `BaseValue` property for more information.

`area(...,'PropertyName',PropertyValue,...)` specifies property name and property value pairs for the patch graphics object created by `area`.

`area(axes_handle,...)` plots into the axes with the handle `axes_handle` instead of into the current axes (`gca`).

`h = area(...)` returns handles of `areaseries` graphics objects.

Creating an area graph of an m -by- n matrix creates n `areaseries` objects (that is, one per column), whereas a 1-by- n vector creates one `areaseries` object.

Some `areaseries` object properties that you set on an individual `areaseries` object set the values for all `areaseries` objects in the graph. See the property descriptions for information on specific properties.

Examples

Create Area Graph

Plot the data in matrix `Y` as an area graph.

```
Y = [1, 5, 3;  
     3, 2, 7;  
     1, 5, 3;  
     2, 6, 1];  
figure  
area(Y)
```

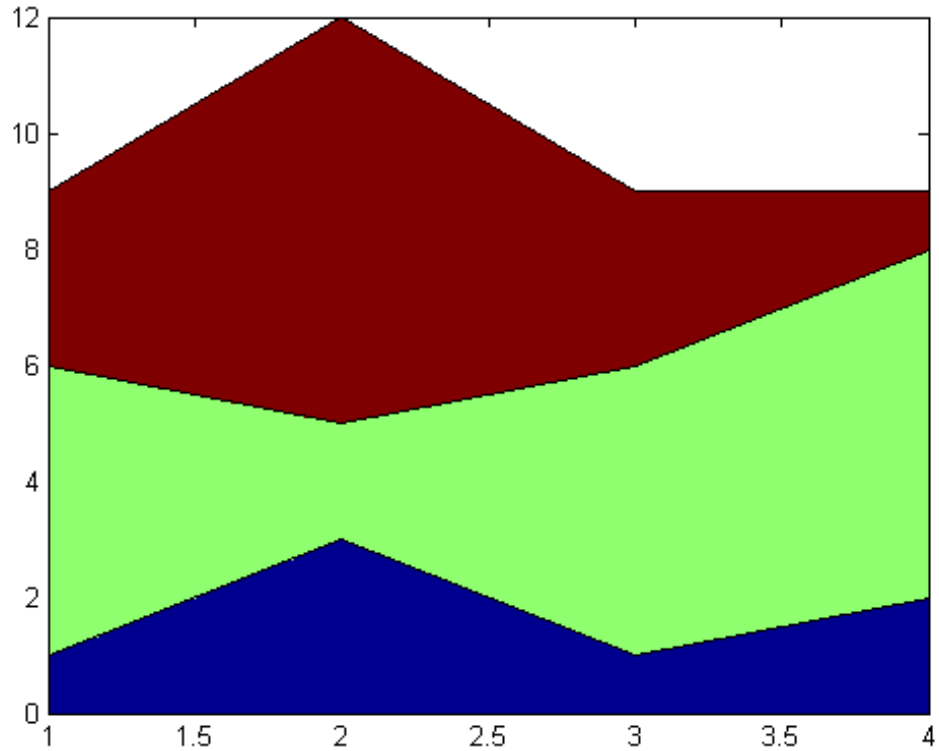

Adjust Base Value of Area Graph

By default, `area` uses the y -axis as the base value. Change the base value by setting the `basevalue` input argument to `-4`.

```
Y = [1, 5, 3;  
     3, 2, 7;  
     1, 5, 3;  
     2, 6, 1];  
figure
```

area

```
basevalue = -4;  
area(Y,basevalue)
```

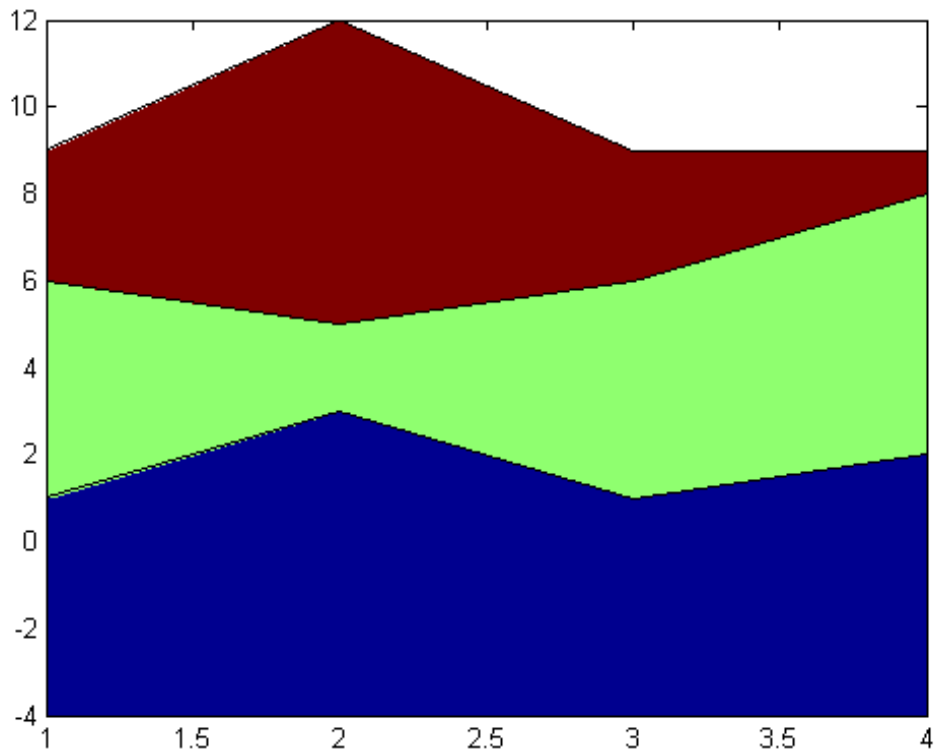

Specify Color and Line Styles for Area Plot

Create an area plot of the data in matrix Y . Set the line style and line width for the three areaseries objects created, one for each column in Y . Store the areaseries object handles in vector h .

```
Y = [1, 5, 3;
```

```
3, 2, 7;  
1, 5, 3;  
2, 6, 1];  
  
figure  
h = area(Y,'LineStyle',':',...  
        'LineWidth',2);
```

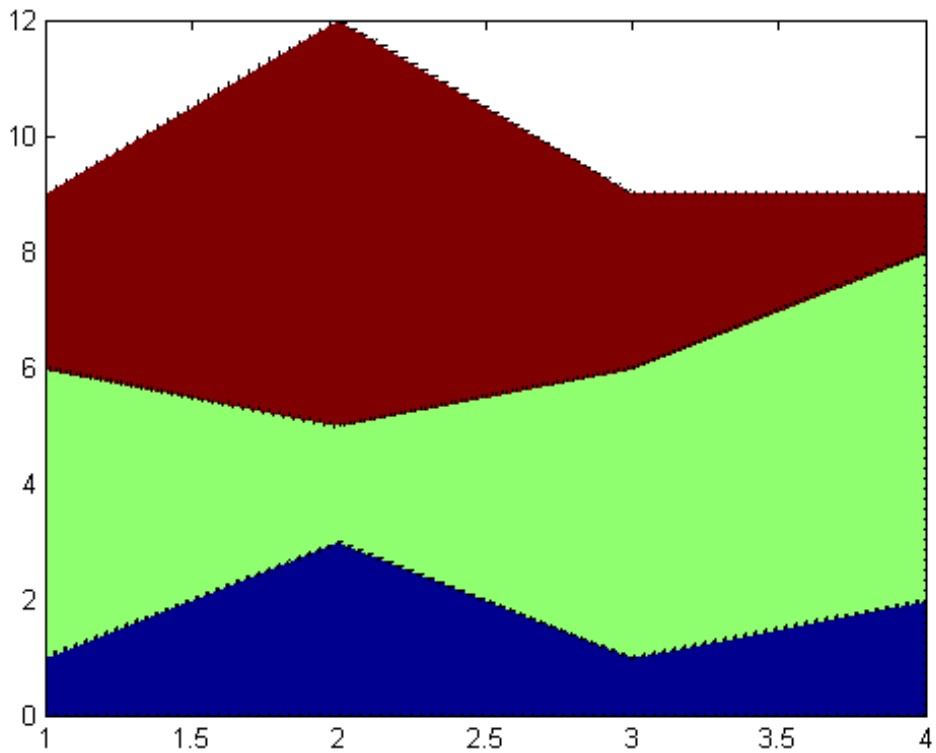

Use the areaseries object handles to specify a different face color for each object.

area

```
set(h(1), 'FaceColor', [0,0.25,0.25]);  
set(h(2), 'FaceColor', [0,0.5,0.5]);  
set(h(3), 'FaceColor', [0,0.75,0.75]);
```

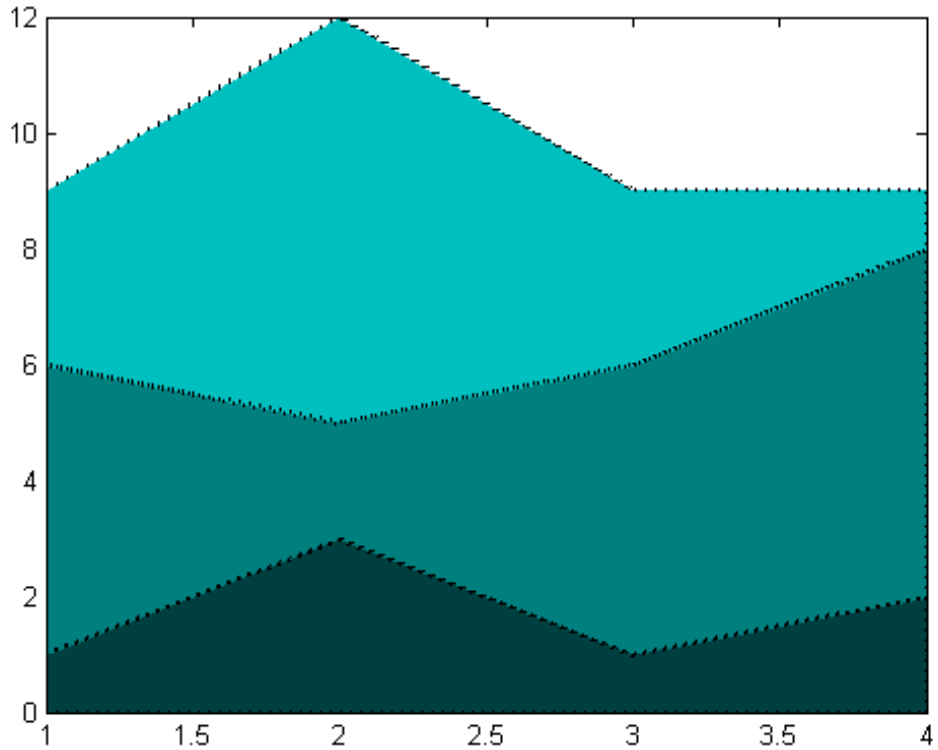

See Also

[bar](#) | [plot](#) | [sort](#) | [Areaseries Properties](#)

How To

- “Compare Data Sets Using Overlaid Area Graphs”

Purpose

Define areaseries properties

Modifying Properties

You can set and query graphics object properties using the set and get commands or with the property editor (propertyeditor).

Note that you cannot define default properties for areaseries objects.

See “Plot Objects” for more information on areaseries objects.

Areaseries Property Descriptions

This section provides a description of properties. Curly braces { } enclose default values.

Annotation

hg.Annotation object (read-only)

Control the display of areaseries objects in legends. Specifies whether this areaseries object is represented in a figure legend.

Querying the Annotation property returns the handle of an hg.Annotation object. The hg.Annotation object has a property called LegendInformation, which contains an hg.LegendEntry object.

Once you have obtained the hg.LegendEntry object, you can set its IconDisplayStyle property to control whether the areaseries object is displayed in a figure legend.

IconDisplayStyle Value	Purpose
on	Include the areaseries object in a legend as one entry, but not its children objects
off	Do not include the areaseries or its children in a legend (default)
children	Include only the children of the areaseries as separate entries in the legend

Areaseries Properties

Setting the IconDisplayStyle Property

These commands set the `IconDisplayStyle` of a graphics object with handle `hobj` to `children`, which causes each child object to have an entry in the legend:

```
hAnnotation = get(hobj, 'Annotation');  
hLegendEntry = get(hAnnotation, 'LegendInformation');  
set(hLegendEntry, 'IconDisplayStyle', 'children')
```

Using the IconDisplayStyle Property

See “Control Legend Content” for more information and examples.

BaseValue

double: *y*-axis value

Value where filled area base is drawn. Specify the value along the *y*-axis at which the MATLAB software draws the baseline of the bottommost filled area. The default is 0.

BeingDeleted

on | {off} (read-only)

This object is being deleted. Mechanism to determine if objects are in the process of being deleted. MATLAB sets the `BeingDeleted` property to `on` when the object’s delete function callback is called (see the `DeleteFcn` property). It remains set to `on` while the delete function executes, after which the object no longer exists.

For example, an object’s delete function calls other functions that act on a number of different objects. If a function does not need to perform an action on an about-be-deleted object, it can check the object’s `BeingDeleted` property before acting.

BusyAction

cancel | {queue}

Callback queuing

Determines how MATLAB handles the execution of interrupting callbacks.

A *running* callback is the currently executing callback. The *interrupting* callback is the callback that tries to interrupt the *running* callback. The `BusyAction` property of the *interrupting* callback determines how MATLAB handles its execution. When the `BusyAction` property is set to:

- 'queue' — Puts the *interrupting* callback in a queue to be processed after the *running* callback finishes execution.
- 'cancel' — Discards the *interrupting* callback as MATLAB finishes execution.

For information about how the `Interruptible` property of the callback controls whether other callbacks can interrupt the *running* callback, see the `Interruptible` property description.

`ButtonDownFcn`
string | function handle

Button press callback function. Executes whenever you press a mouse button while the pointer is over this object, but not over another graphics object. See the `HitTestArea` property for information about selecting objects of this type.

See the figure's `SelectionType` property to determine if modifier keys were also pressed.

This property can be:

- A string that is a valid MATLAB expression
- The name of a MATLAB file
- A function handle

Set this property to a function handle that references the callback. The expressions execute in the MATLAB workspace.

Areaseries Properties

For information on the syntax of callback functions, see [Function Handle Callbacks](#).

Children

array of graphics object handles

Children of this object. The handle of a patch object that is the child of this object (whether visible or not).

If a child object's `HandleVisibility` property is `callback` or `off`, its handle does not show up in this object's `Children` property. If you want the handle in the `Children` property, set the root `ShowHiddenHandles` property to `on`. For example:

```
set(0, 'ShowHiddenHandles', 'on')
```

Clipping

{on} | off

Clipping mode. MATLAB clips graphs to the axes plot box by default. If you set `Clipping` to `off`, portions of graphs appear outside the axes plot box. This occurs if you create a plot object, set `hold` to `on`, freeze axis scaling (`axis manual`), and then create a larger plot object.

CreateFcn

function handle | cell array containing function handle and additional arguments | string (not recommended)

Callback function executed during object creation. Defines a callback that executes when MATLAB creates an object. The default is an empty array.

You must specify the callback during the creation of the object. For example:

```
graphicfcn(y, 'CreateFcn', @CallbackFcn)
```

where `@CallbackFcn` is a function handle that references the callback function and `graphicfcn` is the plotting function which creates this object.

MATLAB executes this routine after setting all other object properties. Setting this property on an existing object has no effect.

The handle of the object whose `CreateFcn` is being executed is accessible only through the root `CallbackObject` property, which you can query using `gcbo`.

For information on the syntax of callback functions, see [Function Handle Callbacks](#).

DeleteFcn

function handle | cell array containing function handle and additional arguments | string (not recommended)

Callback executed during object deletion. Executes when this object is deleted (for example, this might happen when you issue a `delete` command on the object, its parent axes, or the figure containing it). MATLAB executes the callback before destroying the object's properties so the callback routine can query these values. The default is an empty array.

The handle of the object whose `DeleteFcn` is being executed is accessible only through the root `CallbackObject` property, which can be queried using `gcbo`.

For information on the syntax of callback functions, see [Function Handle Callbacks](#).

See the `BeingDeleted` property for related information.

DisplayName

string

Areaseries Properties

String used by legend. The `legend` function uses the `DisplayName` property to label the areaseries object in the legend. The default is an empty string.

- If you specify string arguments with the `legend` function, MATLAB set `DisplayName` to the corresponding string and uses that string for the legend.
- If `DisplayName` is empty, `legend` creates a string of the form, `['data' n]`, where `n` is the number assigned to the object based on its location in the list of legend entries. However, `legend` does not set `DisplayName` to this string.
- If you edit the string directly in an existing legend, MATLAB set `DisplayName` to the edited string.
- If you specify a string for the `DisplayName` property and create the legend using the figure toolbar, then MATLAB uses the string defined by `DisplayName`.
- To add a legend programmatically that uses the `DisplayName` string, call `legend` with the `toggle` or `show` option.

See “Control Legend Content” for more information and examples.

EdgeColor

`{[0 0 0]} | none | ColorSpec`

Color of line separating filled areas. You can set the color of the edges of filled areas to a three-element RGB vector or one of the MATLAB predefined names, including the string `none`. The default value is `[0 0 0]` (black). See the `ColorSpec` reference page for more information on specifying color.

EraseMode

`{normal} | none | xor | background`

Erase mode. Controls the technique MATLAB uses to draw and erase objects. Use alternative erase modes for creating animated

sequences, where control of the way individual objects are redrawn is necessary to improve performance and obtain the desired effect.

- **normal** — Redraw the affected region of the display, performing the three-dimensional analysis necessary to correctly render all objects. This mode produces the most accurate picture, but is the slowest. The other modes are faster, but do not perform a complete redraw and are therefore less accurate.
- **none** — Do not erase the object when it is moved or destroyed. While the object is still visible on the screen after erasing with `EraseMode none`, you cannot print it because MATLAB stores no information about its former location.
- **xor** — Draw and erase the object by performing an exclusive OR (XOR) with the color of the screen beneath it. This mode does not damage the color of the objects beneath it. However, the object's color depends on the color of whatever is beneath it on the display.
- **background** — Erase the object by redrawing it in the axes background `Color`, or the figure background `Color` if the axes `Color` property is `none`. This damages objects that are behind the erased object, but properly colors the erased object.

Set the axes background color with the axes `Color` property. Set the figure background color with the figure `Color` property.

Printing with Nonnormal Erase Modes

MATLAB always prints figures as if the `EraseMode` of all objects is `normal`. This means graphics objects created with `EraseMode` set to `none`, `xor`, or `background` can look different on screen than on paper. On screen, MATLAB mathematically combines layers of colors (for example, performing an XOR on a pixel color with that of the pixel behind it) and ignore three-dimensional sorting to obtain greater rendering speed. However, these techniques are not applied to the printed output.

Areaseries Properties

You can use the `getframe` command or other screen capture applications to create an image of a figure containing nonnormal mode objects.

FaceColor

{flat} | none | ColorSpec

Color of filled areas.

- **ColorSpec** — A three-element RGB vector or one of the MATLAB predefined names, specifying a single color for all filled areas.
- **none** — Do not draw faces. Note that MATLAB draws `EdgeColor` independently of `FaceColor`.
- **flat** — The object uses the figure colormap to determine the color of the filled areas.

HandleVisibility

{on} | callback | off

Control access to object's handle. Determines when an object's handle is visible in its parent's list of children. `HandleVisibility` is useful for preventing command-line users from accidentally accessing objects that you need to protect for some reason.

- **on** — Handles are always visible.
- **callback** — Handles are visible from within callback routines or functions invoked by callback routines, but not from within functions invoked from the command line. This provides a means to protect GUIs from command-line users, while allowing callback routines to have access to object handles.
- **off** — Handles are invisible at all times. Use this option when a callback invokes a function that could damage the GUI (such as evaluating a user-typed string). This option temporarily hides its own handles during the execution of that function.

Functions Affected by Handle Visibility

When a handle is not visible in its parent's list of children, it cannot be returned by functions that obtain handles by searching the object hierarchy or querying handle properties. This includes `get`, `findobj`, `gca`, `gcf`, `gco`, `newplot`, `cla`, `clf`, and `close`.

Properties Affected by Handle Visibility

When a handle's visibility is restricted using `callback` or `off`, the object's handle does not appear in its parent's `Children` property, figures do not appear in the root's `CurrentFigure` property, objects do not appear in the root's `CallbackObject` property or in the figure's `CurrentObject` property, and axes do not appear in their parent's `CurrentAxes` property.

Overriding Handle Visibility

You can set the root `ShowHiddenHandles` property to `on` to make all handles visible regardless of their `HandleVisibility` settings. This does not affect the values of the `HandleVisibility` properties. See also `findall`.

Handle Validity

Hidden handles are still valid. If you know an object's handle, you can `set` and `get` its properties and pass it to any function that operates on handles.

Note If you change one data source property to a variable that contains data of a different dimension, you might cause the function to generate a warning and not render the graph until you have changed all data source properties to appropriate values.

```
HitTest  
    {on} | off
```

Areaseries Properties

Selectable by mouse click. Determines whether this object can become the current object (as returned by the `gco` command and the figure `CurrentObject` property) as a result of a mouse click on the objects that compose the area graph. If `HitTest` is `off`, clicking this object selects the object below it (which is usually the axes containing it).

`HitTestArea`
`on` | `{off}`

Select areaseries object on filled area or extent of graph. Select plot objects by:

- Clicking an area (default).
- Clicking anywhere in the extent of the area plot.

When `HitTestArea` is `off`, you must click an area to select the `areaseries` object. When `HitTestArea` is `on`, you can select the `areaseries` object by clicking anywhere within the extent of the area graph (that is, anywhere within a rectangle that encloses all the area plots).

`Interruptible`
`off` | `{on}`

Callback routine interruption

Controls whether MATLAB can interrupt an object's callback function when subsequent callbacks attempt to interrupt it.

For Graphics objects, the `Interruptible` property affects only the callbacks for the `ButtonDownFcn` property. A *running* callback is the currently executing callback. The *interrupting* callback is the callback that tries to interrupt the *running* callback. MATLAB handles both the callbacks based on the `Interruptible` property of the object of the *running* callback.

When the `Interruptible` property is set to:

- 'off', MATLAB finishes execution of the *running* callback without any interruptions
- 'on', these conditions apply:
 - If there is a *drawnow*, *figure*, *getframe*, *waitfor*, or *pause* command in the *running* callback, then MATLAB executes the *interrupting* callbacks which are already in the queue and returns to finish execution of the current callback.
 - If one of the above functions is not in the *running* callback, then MATLAB finishes execution of the current callback without any interruption.

`BusyAction` property of the object of interrupting callback determines whether the callback should be ignored or should be put in the queue.

Setting `Interruptible` property to on (default), allows a callback from other graphics objects to interrupt callback functions originating from this object.

Note MATLAB does not save the state of properties or the display when an interruption occurs. For example, the handle returned by the `gca` or `gcf` command may be changed as another callback is executed.

After the function that interrupts a callback completes, the callback resumes execution where it halted when interrupted. For more information, see “Control Callback Execution and Interruption”.

`LineStyle`

{-} | -- | : | -. | none

Line style of edges of filled areas.

Areaseries Properties

Line Style Specifiers Table

Specifier	Line Style
'-'	Solid line (default)
'--'	Dashed line
'.'	Dotted line
'-.'	Dash-dot line
'none'	No line

LineWidth

size in points

Width of linear objects and edges of filled areas. Specify in points. 1 point = $1/72$ inch. The default is 0.5 points.

Parent

handle of parent axes, hggroup, or hgtransform

Parent of object. Handle of the object's parent. The parent is normally the axes, hggroup, or hgtransform object that contains the object.

Selected

on | {off}

Object selection state. When you set this property to on, MATLAB displays selection handles at the corners and midpoints if the SelectionHighlight property is also on (the default). You can, for example, define the ButtonDownFcn callback to set this property to on, thereby indicating that this particular object is selected. This property is also set to on when an object is manually selected in plot edit mode.

SelectionHighlight

{on} | off

Object highlighted when selected.

- **on** — MATLAB indicates the selected state by drawing four edge handles and four corner handles.
- **off** — MATLAB does not draw the handles except when in plot edit mode and objects are selected manually.

Tag

string

User-specified object label. Provides a means to identify graphics objects with a user-specified label. The default is an empty string.

Use the `Tag` property and the `findobj` function to manipulate specific objects within a plotting hierarchy.

For example, create an `areaseries` object and set the `Tag` property.

```
t = area(Y, 'Tag', 'area1')
```

When you want to access objects of a given type, use `findobj` to find the object's handle. The following statement changes the `FaceColor` property of the object whose `Tag` is `area1`.

```
set(findobj('Tag', 'area1'), 'FaceColor', 'red')
```

Type

string (read-only)

Type of graphics object. String that identifies the class of the graphics object. Use this property to find all objects of a given type within a plotting hierarchy. For `areaseries` objects, `Type` is `'hgroup'`.

The following statement finds all the `hgroup` objects in the current axes.

```
t = findobj(gca, 'Type', 'hgroup');
```

Areaseries Properties

UIContextMenu

handle of uicontextmenu object

Associate context menu with object. Handle of a uicontextmenu object created in the object's parent figure. Use the uicontextmenu function to create the context menu. MATLAB displays the context menu whenever you right-click over the object. The default value is an empty array.

UserData

array

User-specified data. Data you want to associate with this object (including cell arrays and structures). The default value is an empty array. MATLAB does not use this data, but you can access it using the set and get commands.

Visible

{on} | off

Visibility of object and its children.

- on — Object and all children of the object are visible unless the child object's Visible property is off.
- off — Object not displayed. However, the object still exists and you can set and query its properties.

XData

vector | matrix

x-axis values for graph. The x-axis values for graphs are specified by the X input argument. If XData is a vector, length(XData) must equal length(YData) and must be monotonic. If XData is a matrix, size(XData) must equal size(YData) and each column must be monotonic.

You can use XData to define meaningful coordinates for an underlying surface whose topography is being mapped.

XDataMode

{auto} | manual

Use automatic or user-specified x-axis values. If you specify XData (by setting the XData property or specifying the X input argument), MATLAB sets this property to manual and uses the specified values to label the x-axis.

If you set XDataMode to auto after specifying XData, MATLAB resets the x-axis ticks to `1:size(YData,1)` or to the column indices of the ZData, overwriting any previous values for XData.

XDataSource

MATLAB variable, as a string

Link XData to MATLAB variable. Set this property to a MATLAB variable that is evaluated in the base workspace to generate the XData. The default value is an empty array.

```
set(h, 'XDataSource', 'xdatabasename')
```

MATLAB requires a call to `refreshdata` when you set this property. Changing workspace variables used as an object's XDataSource does not change the object's XData values, but you can use `refreshdata` to force an update of the object's data. `refreshdata` also lets you specify that the data source variable be evaluated in the workspace of a function from which you call `refreshdata`.

Note If you change one data source property to a variable that contains data of a different dimension, you might cause the function to generate a warning and not render the graph until you have changed all data source properties to appropriate values.

YData

vector | matrix

Areaseries Properties

Area plot data. `YData` contains the data plotted as filled areas (the `Y` input argument). If `YData` is a vector, `area` creates a single filled area whose upper boundary is defined by the elements of `YData`. If `YData` is a matrix, `area` creates one filled area per column, stacking each on the previous plot. The default value is the `Y` input argument.

The input argument `Y` in the `area` function calling syntax assigns values to `YData`.

`YDataSource`

MATLAB variable, as a string

Link YData to MATLAB variable. Set this property to a MATLAB variable that is evaluated in the base workspace to generate the `YData`. The default value is an empty array.

```
set(h, 'YDataSource', 'Ydatavariablename')
```

MATLAB requires a call to `refreshdata` when you set this property. Changing workspace variables used as an object's `YDataSource` does not change the object's `YData` values, but you can use `refreshdata` to force an update of the object's data. `refreshdata` also lets you specify that the data source variable be evaluated in the workspace of a function from which you call `refreshdata`.

Note If you change one data source property to a variable that contains data of a different dimension, you might cause the function to generate a warning and not render the graph until you have changed all data source properties to appropriate values.

How To

- “Plot Objects”
- “Setting Default Property Values”

Purpose	Convert homogeneous array to table
Syntax	<pre>T = array2table(A) T = array2table(A,Name,Value)</pre>
Description	<p><code>T = array2table(A)</code> converts the m-by-n array, <code>A</code>, to an m-by-n table, <code>T</code>. Each column of <code>A</code> becomes a variable in <code>T</code>.</p> <p><code>array2table</code> uses the input array name appended with the column number for the variable names in the table. If these names are not valid MATLAB identifiers, <code>array2table</code> uses strings of the form <code>'Var1'</code>, ..., <code>'VarN'</code>, where N is the number of columns in <code>A</code>.</p> <p><code>T = array2table(A,Name,Value)</code> creates a table from an array, <code>A</code>, with additional options specified by one or more <code>Name,Value</code> pair arguments.</p> <p>For example, you can specify row names or variable names to include in the table.</p>
Input Arguments	<p>A - Input array <i>matrix</i></p> <p>Input array, specified as a matrix.</p> <p>Data Types <code>single</code> <code>double</code> <code>int8</code> <code>int16</code> <code>int32</code> <code>int64</code> <code>uint8</code> <code>uint16</code> <code>uint32</code> <code>uint64</code> <code>logical</code> <code>char</code> <code>struct</code> <code>cell</code></p> <p>Complex Number Support: Yes</p> <p>Name-Value Pair Arguments</p> <p>Specify optional comma-separated pairs of <code>Name,Value</code> arguments. <code>Name</code> is the argument name and <code>Value</code> is the corresponding value. <code>Name</code> must appear inside single quotes (<code>' '</code>). You can specify several name and value pair arguments in any order as <code>Name1,Value1,...,NameN,ValueN</code>.</p>

array2table

Example: 'RowNames', {'row1', 'row2', 'row3'} uses the row names, row1, row2, and row3 for the table, T.

'RowNames' - Row names for T

{} (default) | cell array of nonempty, distinct strings

Row names for T, specified as the comma-separated pair consisting of 'RowNames' and a cell array of nonempty, distinct strings. The number of strings must equal the number of rows, `size(A,1)`.

'VariableNames' - Variable names for T

cell array of nonempty, distinct strings

Variable names for T, specified as the comma-separated pair consisting of 'VariableNames' and a cell array of nonempty, distinct strings. The number of strings must equal the number of variables, `size(A,2)`.

Furthermore, the strings must be valid MATLAB identifiers. If valid MATLAB identifiers are not available for use as variable names, MATLAB uses a cell array of N strings of the form {'Var1' ... 'Var N '} where N is the number of variables. You can determine valid MATLAB variable names using the function `isvarname`.

Output Arguments

T - Output table

table

Output table, returned as a table. The table can store metadata such as descriptions, variable units, variable names, and row names. For more information, see [Table Properties](#).

Examples

Convert Numeric Array to Table

Create an array of numeric data.

```
A = [1 4 7; 2 5 8; 3 6 9]
```

```
A =
```

```
     1     4     7
```

```

     2     5     8
     3     6     9

```

Convert the array, A, to a table.

```
T = array2table(A)
```

```
T =
```

```

     A1     A2     A3
     —     —     —
     1     4     7
     2     5     8
     3     6     9

```

The table has variable names that append the column number to the input array name, A.

Convert Array to Table Including Variable Names

Create an array of numeric data.

```
A = [1 12 30.48; 2 24 60.96; 3 36 91.44]
```

```
A =
```

```

     1.0000     12.0000     30.4800
     2.0000     24.0000     60.9600
     3.0000     36.0000     91.4400

```

Convert the array, A, to a table and include variable names.

```
T = array2table(A,...
    'VariableNames',{'Feet' 'Inches' 'Centimeters'})
```

```
T =
```

```

     Feet     Inches     Centimeters

```

array2table

1	12	30.48
2	24	60.96
3	36	91.44

Tips

- If A is a cell array, use `cell2table(A)` to create a table from the contents of the cells in A. Each variable in the table is numeric or a cell array of strings. `array2table(A)` creates a table where each variable is a column of cells.

See Also

`table2array` | `cell2table` | `struct2table` | `table` | `isvarname`

Related Examples

- “Access Data in a Table”

Purpose

Apply function to each element of array

Syntax

```
[B1,...,Bm] = arrayfun(func,A1,...,An)
[B1,...,Bm] = arrayfun(func,A1,...,An,Name,Value)
```

Description

[B1,...,Bm] = arrayfun(func,A1,...,An) calls the function specified by function handle `func` and passes elements from arrays A1,...,An, where `n` is the number of inputs to function `func`. Output arrays B1,...,Bm, where `m` is the number of outputs from function `func`, contain the combined outputs from the function calls. The `i`th iteration corresponds to the syntax [B1(i),...,Bm(i)] = func(A1{i},...,An{i}). The arrayfun function does not perform the calls to function `func` in a specific order.

[B1,...,Bm] = arrayfun(func,A1,...,An,Name,Value) calls function `func` with additional options specified by one or more Name,Value pair arguments. Possible values for Name are 'UniformOutput' or 'ErrorHandler'.

Input Arguments**func**

Handle to a function that accepts `n` input arguments and returns `m` output arguments.

If function `func` corresponds to more than one function file (that is, if `func` represents a set of overloaded functions), MATLAB determines which function to call based on the class of the input arguments.

A1,...,An

Arrays that contain the `n` inputs required for function `func`. Each array must have the same dimensions. Arrays can be numeric, character, logical, cell, structure, or user-defined object arrays.

If any input `A` is a user-defined object array, and you overloaded the `subsref` or `size` methods, arrayfun requires that:

- The `size` method returns an array of type `double`.
- The object array supports linear indexing.

- The product of the sizes returned by the `size` method does not exceed the limit of the array, as defined by linear indexing into the array.

Name-Value Pair Arguments

Specify optional comma-separated pairs of `Name`, `Value` arguments. `Name` is the argument name and `Value` is the corresponding value. `Name` must appear inside single quotes (' '). You can specify several name and value pair arguments in any order as `Name1, Value1, ..., NameN, ValueN`.

'UniformOutput'

Logical value, as follows:

- | | |
|------------------------|---|
| <code>true</code> (1) | Indicates that for all inputs, each output from function <code>func</code> is a cell array or a scalar value that is always of the same type and size. The <code>arrayfun</code> function combines the outputs in arrays <code>B1, ..., Bm</code> , where <code>m</code> is the number of function outputs. Each output array is of the same type as the individual function outputs. |
| <code>false</code> (0) | Requests that the <code>arrayfun</code> function combine the outputs into cell arrays <code>B1, ..., Bm</code> . The outputs of function <code>func</code> can be of any size or type. |

Default: `true`

'ErrorHandler'

Handle to a function that catches any errors that occur when MATLAB attempts to execute function `func`. Define this function so that it rethrows the error or returns valid outputs for function `func`.

MATLAB calls the specified error-handling function with two input arguments:

- A structure with these fields:

identifier	Error identifier.
message	Error message text.
index	Linear index corresponding to the element of the input cell array at the time of the error.

- The set of input arguments to function `func` at the time of the error.

Output Arguments

B1,...,Bm

Arrays that collect the m outputs from function `func`. Each array `B` is the same size as each of the inputs `A1, . . . , An`.

Function `func` can return output arguments of different classes. However, if `UniformOutput` is `true` (the default):

- The individual outputs from function `func` must be scalar values (numeric, logical, character, or structure) or cell arrays.
- The class of a particular output argument must be the same for each set of inputs. The class of the corresponding output array is the same as the class of the outputs from function `func`.

Examples

To run the examples in this section, create a nonscalar structure array with arrays of different sizes in field `f1`.

```
s(1).f1 = rand(3, 6);
s(2).f1 = magic(12);
s(3).f1 = ones(5, 10);
```

Count the number of elements in each `f1` field.

```
counts = arrayfun(@(x) numel(x.f1), s)
```

The syntax `@(x)` creates an anonymous function. This code returns

```
counts =
```

```
18  144  50
```

Compute the size of each array in the f1 fields.

```
[nrows, ncols] = arrayfun(@(x) size(x.f1), s)
```

This code returns

```
nrows =  
     3     12     5  
ncols =  
     6     12    10
```

Compute the mean of each column in the f1 fields of s. Because the output is nonscalar, set UniformOutput to false.

```
averages = arrayfun(@(x) mean(x.f1), s, 'UniformOutput', false)
```

This code returns

```
averages =  
    [1x6 double]    [1x12 double]    [1x10 double]
```

Create additional nonscalar structures t and u, and test for equality between the arrays in fields f1 across structures s, t, and u.

```
t = s; t(1).f1(:)=0;  
u = s; u(2).f1(:)=0;
```

```
same = arrayfun(@(x,y,z) isequal(x.f1, y.f1, z.f1), s, t, u)
```

This code returns

```
same =  
     0     0     1
```

See Also

[structfun](#) | [cellfun](#) | [spfun](#) | [function_handle](#) | [cell2mat](#)

Tutorials

- “Anonymous Functions”

FTP.ascii

Purpose Set FTP transfer type to ASCII

Syntax `ascii(ftpobj)`

Description `ascii(ftpobj)` sets the download and upload FTP mode to ASCII, which converts new line characters. Use this method only for text files, including HTML pages and Rich Text Format (RTF) files.

Input Arguments **ftpobj**
FTP object created by `ftp`.

Examples Connect to the MathWorks FTP server, and switch from binary (default) to ASCII mode:

```
mw=ftp('ftp.mathworks.com');  
ascii(mw)
```

See Also `binary` | `ftp`

Purpose Inverse secant in radians

Syntax $Y = \text{asec}(X)$

Description $Y = \text{asec}(X)$ returns the inverse secant (arcsecant) for each element of X .

The `asec` function operates element-wise on arrays. The function's domains and ranges include complex values. All angles are in radians.

Examples **Graph of Inverse Secant Function**

Graph the inverse secant over the domains $-5 \leq x \leq -1$ and $1 \leq x \leq 5$.

```
x1 = -5:0.01:-1;  
x2 = 1:0.01:5;  
plot(x1,asec(x1),x2,asec(x2)), grid on
```

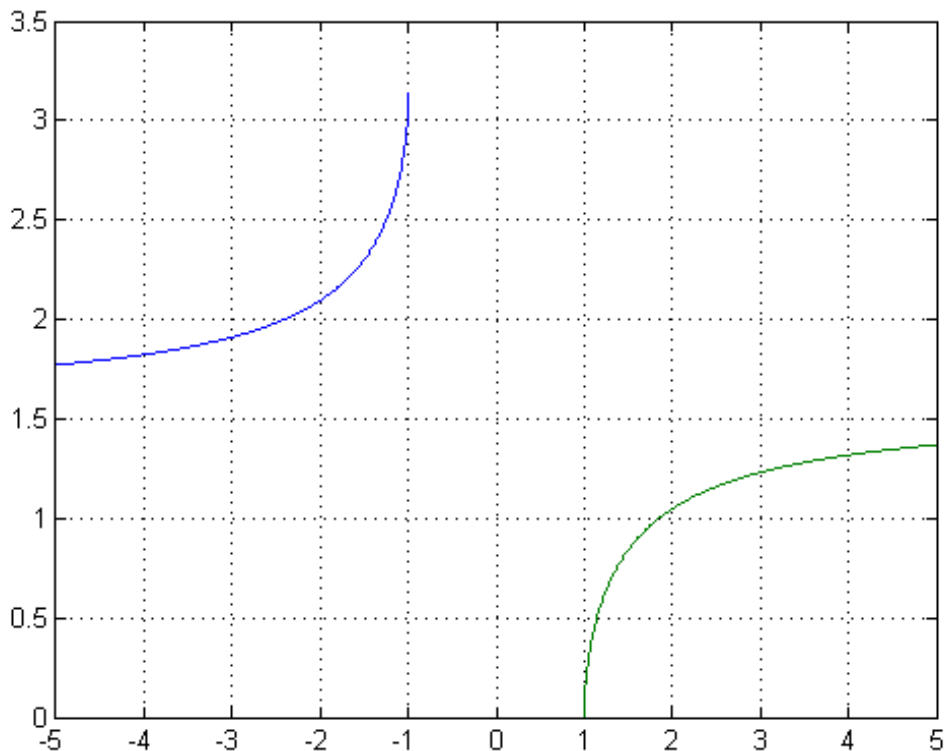

Definitions Inverse Secant

The inverse secant can be defined as

$$\sec^{-1}(z) = \cos^{-1}\left(\frac{1}{z}\right).$$

See Also [asecd](#) | [asech](#) | [sec](#)

Purpose	Inverse secant in degrees
Syntax	$Y = \text{asecd}(X)$
Description	$Y = \text{asecd}(X)$ returns the inverse secant (sec^{-1}) of the elements of X in degrees. The function's domain and range include complex values. For real elements of X in the domain $[-\text{Inf}, 1]$ and $[1, \text{Inf}]$, asecd returns values in the range $[0, 180]$. For values of X outside this range, asecd returns complex values.
Input Arguments	<p>X - Secant of angle scalar value vector matrix N-D array</p> <p>Secant of angle, specified as a real-valued or complex-valued scalar, vector, matrix, or N-D array. The asecd operation is element-wise when X is non-scalar.</p> <p>Data Types single double</p> <p>Complex Number Support: Yes</p>
Output Arguments	<p>Y - Angle in degrees scalar value vector matrix N-D array</p> <p>Angle in degrees, returned as a real-valued or complex-valued scalar, vector, matrix, or N-D array of the same size as X.</p>
Examples	<p>Inverse Secant of Vector</p> <pre>x = [10 1 Inf]; y = asecd(x) y = 84.2608 0 90.0000</pre> <p>The asecd operation is element-wise when you pass a vector, matrix, or N-D array.</p>

Inverse Secant of Complex Value

```
asecd(1+i)
```

```
ans =
```

```
64.0864 +30.4033i
```

See Also

[secd](#) | [asec](#) | [sec](#)

Purpose Inverse hyperbolic secant

Syntax $Y = \operatorname{asech}(X)$

Description $Y = \operatorname{asech}(X)$ returns the inverse hyperbolic secant for each element of X .

The `asech` function operates element-wise on arrays. The function's domains and ranges include complex values. All angles are in radians.

Examples **Graph of Inverse Hyperbolic Secant Function**

Graph the inverse hyperbolic secant over the domain $0.01 \leq x \leq 1$.

```
x = 0.01:0.001:1;  
plot(x,asech(x)), grid on
```

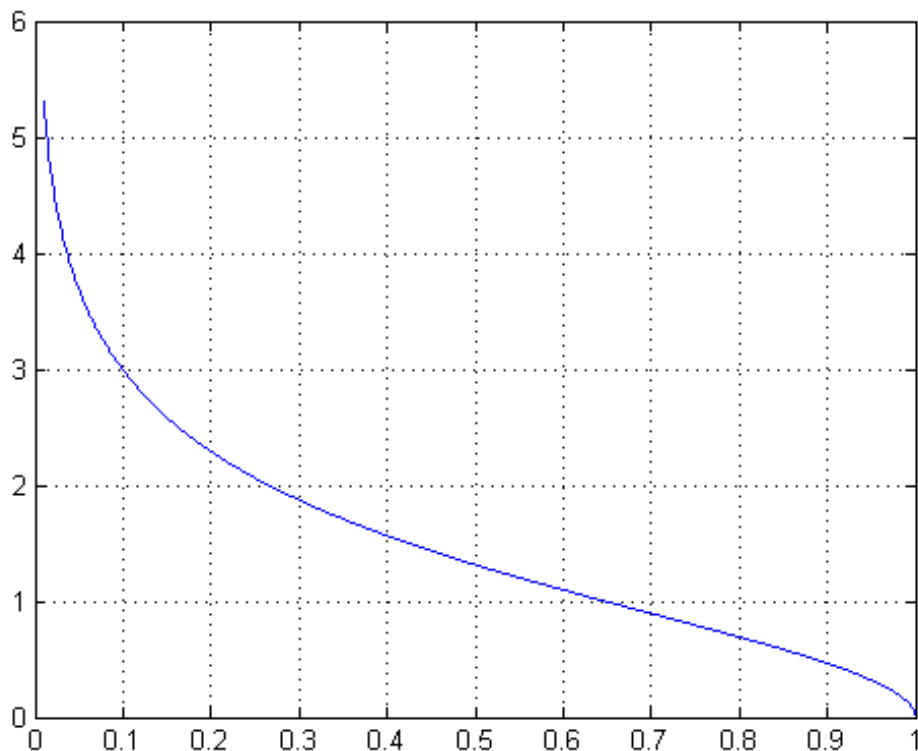

Definitions Inverse Hyperbolic Secant

The inverse hyperbolic secant can be defined as

$$\operatorname{sech}^{-1}(z) = \cosh^{-1}\left(\frac{1}{z}\right).$$

See Also [asec](#) | [sech](#) | [asinh](#) | [acosh](#)

Purpose Inverse sine in radians

Syntax `Y = asin(X)`

Description `Y = asin(X)` returns the inverse sine (arcsine) for each element of `X`. The `asin` function operates element-wise on arrays. The function's domains and ranges include complex values. All angles are in radians. For real elements of `X` in the domain $[-1, 1]$, `asin(X)` is in the range

$$\left[-\frac{\pi}{2}, \frac{\pi}{2}\right].$$

For real elements of `x` outside the range $[-1, 1]$, `asin(X)` is complex.

Examples **Graph of Inverse Sine Function**

Graph the inverse sine over the domain $-1 \leq x \leq 1$.

```
x = -1:.01:1;  
plot(x,asin(x)), grid on
```

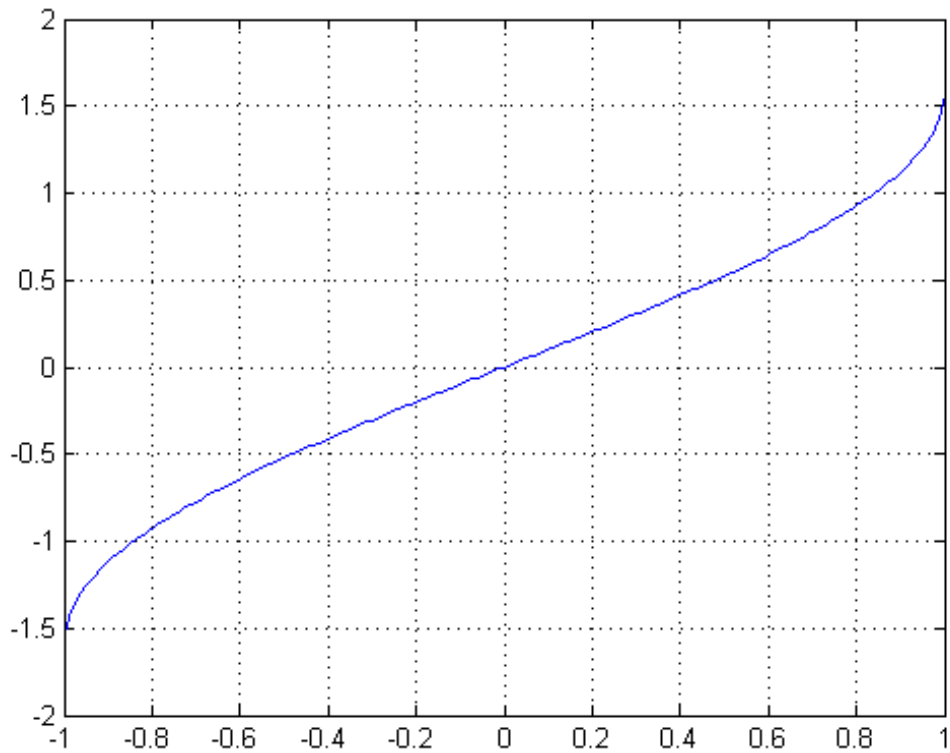

Definitions Inverse Sine

The inverse sine can be defined as

$$\sin^{-1}(z) = -i \log \left[iz + (1 - z^2)^{1/2} \right].$$

See Also `asind` | `sin` | `sind`

Purpose	Inverse sine in degrees
Syntax	$Y = \text{asind}(X)$
Description	$Y = \text{asind}(X)$ returns the inverse sine (\sin^{-1}) of the elements of X in degrees. The function's domain and range include complex values. For real elements of X in the domain $[-1,1]$, asind returns values in the range $[-90,90]$. For values of X outside this range, asind returns complex values.
Input Arguments	X - Sine of angle scalar value vector matrix N-D array Sine of angle, specified as a real-valued or complex-valued scalar, vector, matrix, or N-D array. The asind operation is element-wise when X is nonscalar. Data Types single double Complex Number Support: Yes
Output Arguments	Y - Angle in degrees scalar value vector matrix N-D array Angle in degrees, returned as a real-valued or complex-valued scalar, vector, matrix, or N-D array of the same size as X .
Examples	Inverse Sine of Scalar Show that the inverse sine of 1 is exactly 90° . <code>asind(1)</code> <code>ans =</code> 90

Round-Trip Calculation for Complex Angles

Show that the inverse sine, followed by sine, returns the original values of X .

```
sind(asind([2 3]))
```

```
ans =
```

```
2.0000 3.0000
```

Graph of Inverse Sine Function

Plot the inverse sine function over the domain $-1 \leq x \leq 1$.

```
x = -1:.01:1;  
plot(x,asind(x))  
grid on
```

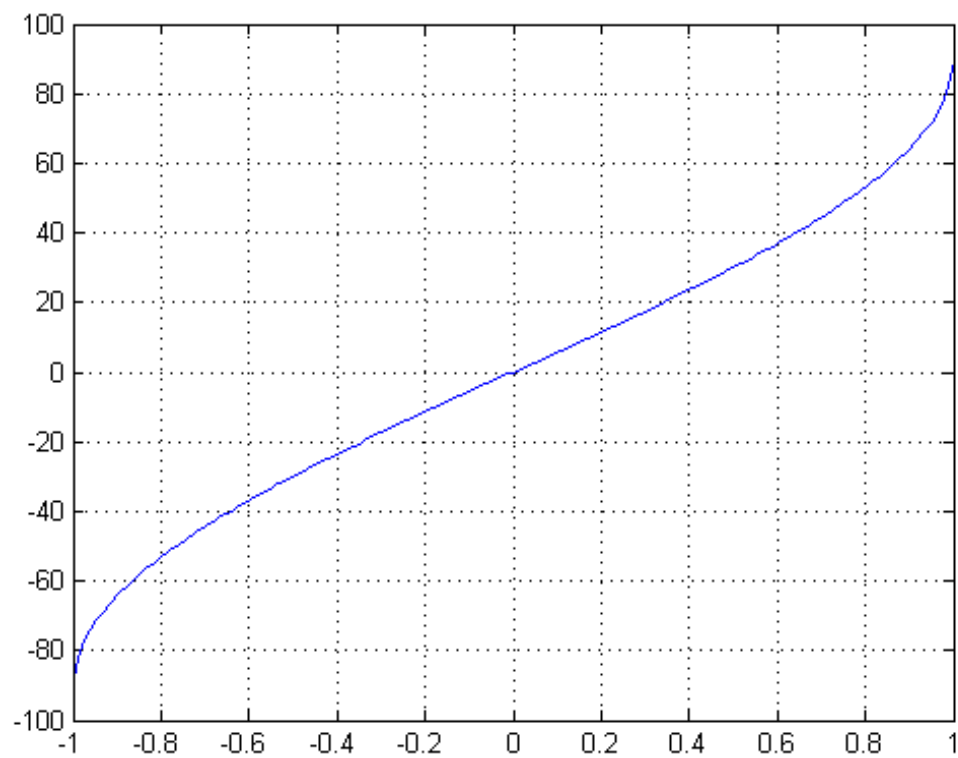

See Also [sind](#) | [sin](#) | [asin](#)

asinh

Purpose Inverse hyperbolic sine

Syntax $Y = \operatorname{asinh}(X)$

Description $Y = \operatorname{asinh}(X)$ returns the inverse hyperbolic sine for each element of X . The `asinh` function operates element-wise on arrays. The function's domains and ranges include complex values. All angles are in radians.

Examples **Graph of Inverse Hyperbolic Sine Function**

Graph the inverse hyperbolic sine over the domain $-5 \leq x \leq 5$.

```
x = -5:.01:5;  
plot(x,asinh(x)), grid on
```

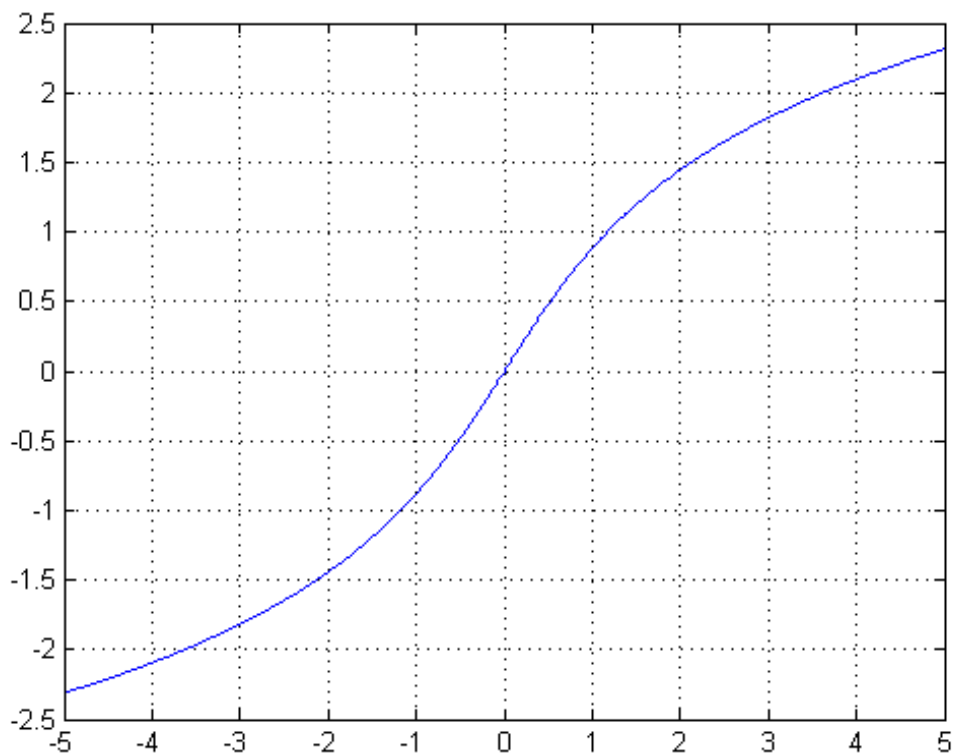

Definitions Inverse Hyperbolic Sine

The inverse hyperbolic sine can be defined as

$$\sinh^{-1}(z) = \log \left[z + (z^2 + 1)^{1/2} \right].$$

See Also [asin](#) | [sinh](#) | [acosh](#)

assert

Purpose Generate error when condition is violated

Syntax

```
assert(expression)
assert(expression, 'msgString')
assert(expression, 'msgString', value1, value2, ...)
assert(expression, 'msgIdent', 'msgString',
value1, value2, ...)
```

Description `assert(expression)` evaluates *expression* and, if it is false, generates an exception. Depending on how the program has been designed to respond to the assertion failure, MATLAB either enters a catch block to handle the condition, or exits the program.

`assert(expression, 'msgString')` evaluates *expression* and, if it is false, generates an exception and displays the string contained in *msgString*. This string must be enclosed in single quotation marks. When *msgString* is the last input to `assert`, the MATLAB software displays it literally, without performing any substitutions on the characters in *msgString*.

`assert(expression, 'msgString', value1, value2, ...)` evaluates *expression* and, if it is false, generates an exception and displays the formatted string contained in *msgString*. The *msgString* string can include escape sequences such as `\t` or `\n`, as well as any of the C language conversion operators supported by the `sprintf` function (e.g., `%s` or `%d`). Additional arguments *value1*, *value2*, etc. provide values that correspond to and replace the conversion operators.

See “Formatting Strings” in the MATLAB Programming Fundamentals documentation for more detailed information on using string formatting commands.

MATLAB makes substitutions for escape sequences and conversion operators in *msgString* in the same way that it does for the `sprintf` function.

`assert(expression, 'msgIdent', 'msgString', value1, value2, ...)` evaluates *expression* and, if it is false, generates an exception and displays the formatted string *msgString*, also tagging the error

with the message identifier *msgIdent*. See “Message Identifiers” in the MATLAB Programming Fundamentals documentation for information.

Examples

This function tests input arguments using `assert`:

```
function write2file(varargin)
min_inputs = 3;
assert(nargin >= min_inputs, ...
    'You must call function %s with at least %d inputs', ...
    mfilename, min_inputs)

infile = varargin{1};
assert(ischar(infile), ...
    'First argument must be a filename.')
assert(exist(infile)~=0, 'File %s not found.', infile)

fid = fopen(infile, 'w');
assert(fid > 0, 'Cannot open file %s for writing', infile)

fwrite(fid, varargin{2}, varargin{3});
```

See Also

```
try | errordlg | error | eval | dbstop | warning | warndlg |
MException | rethrow(MException) | throwAsCaller(MException) |
throw(MException) | addCause(MException) | last(MException) |
getReport(MException)
```

assignin

Purpose Assign value to variable in specified workspace

Syntax `assignin(ws, 'var', val)`

Description `assignin(ws, 'var', val)` assigns the value `val` to the variable `var` in the workspace `ws`. The `var` input must be the array name only; it cannot contain array indices. If `var` does not exist in the specified workspace, `assignin` creates it. `ws` can have a value of 'base' or 'caller' to denote the MATLAB base workspace or the workspace of the caller function.

The `assignin` function is particularly useful for these tasks:

- Exporting data from a function to the MATLAB workspace
- Within a function, changing the value of a variable that is defined in the workspace of the caller function (such as a variable in the function argument list)

Tips The MATLAB base workspace is the workspace that is seen from the MATLAB command line (when not in the debugger). The caller workspace is the workspace of the function that called the currently running function. Note that the base and caller workspaces are equivalent in the context of a function that is invoked from the MATLAB command line. For more information, see “Base and Function Workspaces”.

Examples **Example 1**

This example creates a dialog box for the image display function, prompting a user for an image name and a colormap name. The `assignin` function is used to export the user-entered values to the MATLAB workspace variables `imfile` and `cmap`.

```
prompt = {'Enter image name:', 'Enter colormap name:'};
title = 'Image display - assignin example';
lines = 1;
def = {'my_image', 'hsv'};
answer = inputdlg(prompt, title, lines, def);
```

```
assignin('base', 'imfile', answer{1});
assignin('base', 'cmap', answer{2});
```



Example 2

`assignin` does not assign to specific elements of an array. The following statement generates an error:

```
X = 1:8;
assignin('base', 'X(3:5)', -1);
```

However, you can use the `evalin` function to do this:

```
evalin('base', 'X(3:5) = -1')
X =
     1     2    -1    -1    -1     6     7     8
```

See Also

`evalin`

atan

Purpose Inverse tangent in radians

Syntax $Y = \text{atan}(X)$

Description $Y = \text{atan}(X)$ returns the inverse tangent (arctangent) for each element of X . For real elements of X , $\text{atan}(X)$ is in the range $[-\pi/2, \pi/2]$.

The `atan` function operates element-wise on arrays. The function's domains and ranges include complex values. All angles are in radians.

Examples **Graph of Inverse Tangent Function**

Graph the inverse tangent over the domain $-20 \leq x \leq 20$.

```
x = -20:0.01:20;  
plot(x,atan(x)), grid on
```

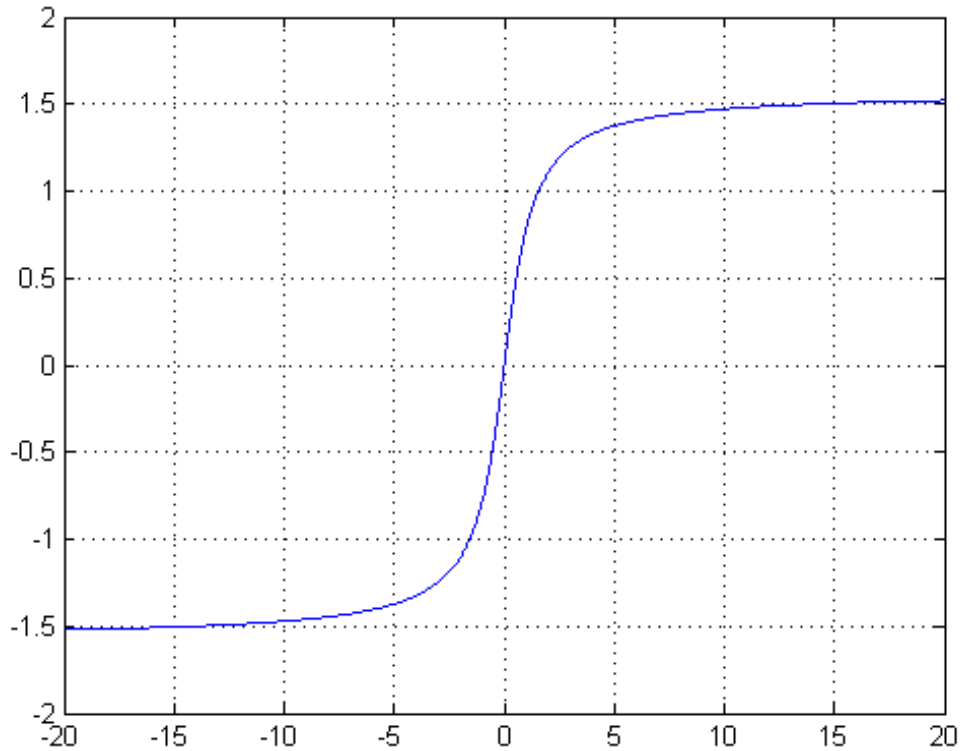
**Definitions** **Inverse Tangent**

The inverse tangent can be defined as

$$\tan^{-1}(z) = \frac{i}{2} \log\left(\frac{i+z}{i-z}\right).$$

See Also atan2 | tan | atand | atanh

atan2

Purpose Four-quadrant inverse tangent

Syntax $P = \text{atan2}(Y,X)$

Description $P = \text{atan2}(Y,X)$ returns an array P the same size as X and Y containing the element-by-element, four-quadrant inverse tangent (arctangent) of Y and X , which must be real.

Elements of P lie in the closed interval $[-\pi, \pi]$, where π is the MATLAB floating-point representation of π . atan uses $\text{sign}(Y)$ and $\text{sign}(X)$ to determine the specific quadrant.

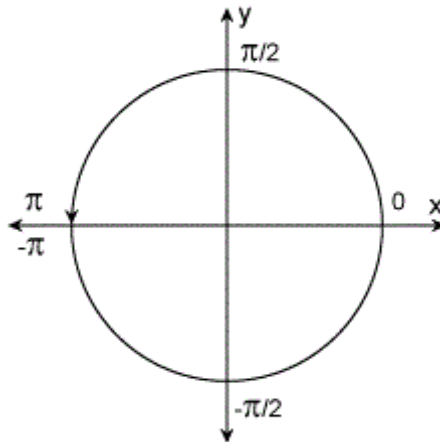

$\text{atan2}(Y,X)$ contrasts with $\text{atan}(Y/X)$, whose results are limited to the interval $[-\pi/2, \pi/2]$, or the right side of this diagram.

Examples Any complex number $z = x + iy$ is converted to polar coordinates with

```
r = abs(z)
theta = atan2(imag(z), real(z))
```

For example,

```
z = 4 + 3i;
```

```
r = abs(z)
theta = atan2(imag(z),real(z))
```

```
r =
    5
```

```
theta =
    0.6435
```

This is a common operation, so MATLAB software provides a function, `angle(z)`, that computes `theta = atan2(imag(z),real(z))`.

To convert back to the original complex number

```
z = r * exp(i * theta)
z =
```

```
    4.0000 + 3.0000i
```

See Also

`angle` | `atan` | `atanh` | `atan2d`

atan2d

Purpose Four-quadrant inverse tangent in degrees

Syntax $D = \text{atan2d}(Y,X)$

Description $D = \text{atan2d}(Y,X)$ returns the four-quadrant inverse tangent of points specified in the x - y plane. The result, D , is expressed in degrees.

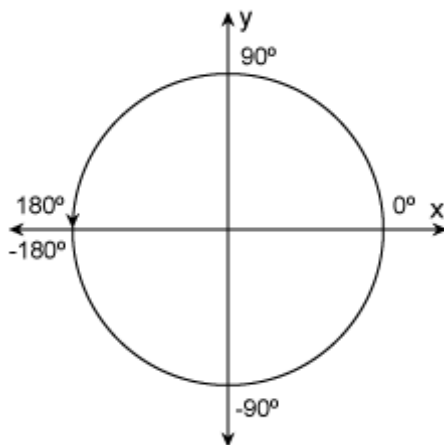

Input Arguments

Y - y-coordinates

scalar value | vector | matrix | N-D array

y -coordinates, specified as a real-valued scalar, vector, matrix, or N-D array.

Data Types

single | double

X - x-coordinates

scalar value | vector | matrix | N-D array

x -coordinates, specified as a real-valued scalar, vector, matrix, or N-D array.

Data Types
single | double

Output Arguments

D - Angles in degrees
scalar value | vector | matrix | N-D array

Angles in degrees, returned as a scalar, vector, matrix, or N-D array. These angles correspond to the points defined by X and Y, and they lie in the closed interval $[-180,180]$.

Examples

Inverse Tangent of Four Points on the Unit Circle

```
x = [1 0 -1 0];  
y = [0 1 0 -1];  
d = atan2d(y,x)
```

```
d =
```

```
0    90   180  -90
```

Tips

- Use `atan2d(Y/X)` for the inverse tangent with results on the interval $[-90, 90]$.

See Also

`atan2` | `atan` | `atan2d` | `tan` | `tand`

atand

Purpose Inverse tangent in degrees

Syntax $Y = \text{atand}(X)$

Description $Y = \text{atand}(X)$ returns the inverse tangent (\tan^{-1}) of the elements of X in degrees. The function's domain and range include complex values. For real elements of X in the domain $[-\text{Inf}, \text{Inf}]$, atand returns values in the range $[-90, 90]$. For complex values of X , atand returns complex values.

Input Arguments **X - Tangent of angle**
scalar value | vector | matrix | N-D array

Tangent of angle, specified as a real-valued or complex-valued scalar, vector, matrix, or N-D array. The atand operation is element-wise when X is non-scalar.

Data Types

single | double

Complex Number Support: Yes

Output Arguments **Y - Angle in degrees**
scalar value | vector | matrix | N-D array

Angle in degrees, returned as a real-valued or complex-valued scalar, vector, matrix, or N-D array of the same size as X .

Examples **Inverse Tangent of Vector**

```
x = [-50 -20 0 20 50];
```

```
y = atand(x)
```

```
y =
```

```
   -88.8542   -87.1376         0    87.1376    88.8542
```

The atand operation is element-wise when you pass a vector, matrix, or N-D array.

Inverse Tangent of Complex Value

```
atand(10+i)
```

```
ans =
```

```
84.3450 + 0.5618i
```

See Also

```
tand | atan | tan | atan2d
```

atanh

Purpose Inverse hyperbolic tangent

Syntax $Y = \operatorname{atanh}(X)$

Description The `atanh` function operates element-wise on arrays. The function's domains and ranges include complex values. All angles are in radians. $Y = \operatorname{atanh}(X)$ returns the inverse hyperbolic tangent for each element of X .

Examples **Graph of Inverse Hyperbolic Tangent Function**

Graph the inverse hyperbolic tangent over the domain $-1 < x < 1$.

```
x = -0.99:0.01:0.99;  
plot(x,atanh(x)), grid on
```

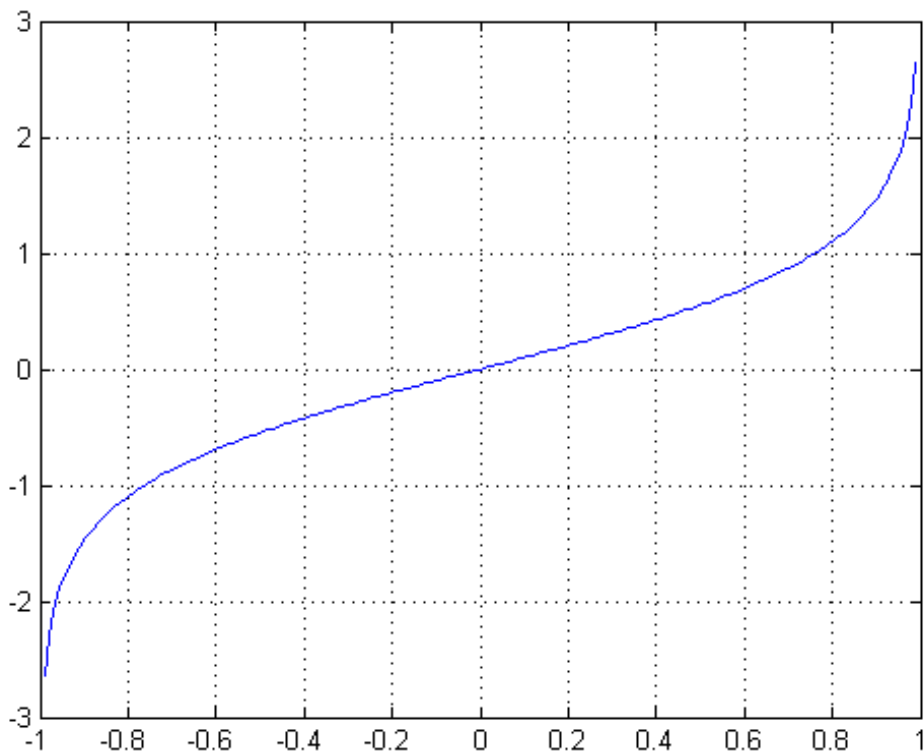

Definitions **Inverse Hyperbolic Tangent**

The inverse hyperbolic tangent can be defined as

$$\tanh^{-1}(z) = \frac{1}{2} \log\left(\frac{1+z}{1-z}\right).$$

See Also atan2 | atan | tanh | asinh | acosh | tan

audiodevinfo

Purpose Information about audio device

Syntax

```
info = audiodevinfo
nDevices = audiodevinfo(IO)
name = audiodevinfo(IO, ID)
DriverVersion = audiodevinfo(IO, ID, 'DriverVersion')
support = audiodevinfo(IO, ID, Fs, nBits, nChannels)

ID = audiodevinfo(IO, name)
ID = audiodevinfo(IO, Fs, nBits, nChannels)
```

Description info = audiodevinfo returns information about the input and output audio devices on the system.

nDevices = audiodevinfo(IO) returns the number of input devices on the system if IO is 1, and returns the number of output devices on the system if IO is 0.

name = audiodevinfo(IO, ID) returns the name of the audio device specified by the device identifier, ID.

DriverVersion = audiodevinfo(IO, ID, 'DriverVersion') returns the name of the driver for the audio device specified by ID.

support = audiodevinfo(IO, ID, Fs, nBits, nChannels) returns 1 if the input or output audio device specified by ID supports the sample rate, number of bits, and number of channels specified by the values of Fs, nBits, and nChannels, respectively. Otherwise, support is 0.

ID = audiodevinfo(IO, name) returns the device identifier of the input or output audio device identified by the device name, name. If no device is found with the specified name, then ID is -1.

`ID = audiodevinfo(IO, Fs, nBits, nChannels)` returns the device identifier of the first input or output device that supports the sample rate, number of bits, and the number of channels specified by the values of `Fs`, `nBits`, and `nChannels`, respectively. If no supporting device is found, then `ID` is `-1`.

Input Arguments

IO - Input or output device

1 | 0

Input or output device, specified as 1 to indicate input, or 0 to indicate output.

ID - Audio device identifier

integer

Audio device identifier, specified as an integer. The device can be an input or output audio device.

Fs - Sample rate

scalar

Sample rate, in hertz, specified as a positive scalar.

Example: 44100

Data Types

single | double

nBits - Number of bits per sample

scalar

Number of bits per sample, specified as a scalar.

Example: 16

Data Types

single | double | int8 | int16 | int32 | int64 | uint8 |
uint16 | uint32 | uint64

nChannels - Number of audio channels

1 | 2

audiodevinfo

Number of audio channels, specified as 1 (mono) or 2 (stereo).

name - Name of input or output device

string

Name of the input or output audio device, specified as a string.

Data Types

char

Output Arguments

info - Information about audio devices

structure array

Information about audio devices, returned as a structure array containing two fields, `input` and `output`. Each field is an array of structures, with each structure containing information about one of the audio input or output devices on the system. The individual device structure fields are:

- `Name` — Name of the device, returned as a string.
- `DriverVersion` — Name of the driver used to communicate with the device, returned as a string.
- `ID` — Device identifier, returned as a scalar.

Examples

View Information About Audio Devices

Call `audiodevinfo` with no inputs to view information about the input and output audio devices on a system.

```
info = audiodevinfo
```

```
info =
```

```
    input: [1x2 struct]  
    output: [1x3 struct]
```

`audiodevinfo` returns a structure containing two fields, `input` and `output`.

View the contents of the input field in the Variables editor.

```
openvar info.input
```

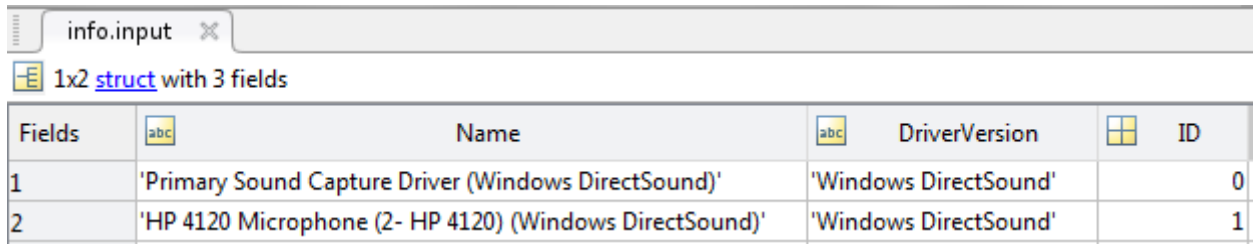

Fields	Name	DriverVersion	ID
1	'Primary Sound Capture Driver (Windows DirectSound)'	'Windows DirectSound'	0
2	'HP 4120 Microphone (2- HP 4120) (Windows DirectSound)'	'Windows DirectSound'	1

The Variables editor displays the input audio device names, driver used, and device identifiers. The values on your system might differ from this example.

View Number of Output Devices

View the number of output audio devices on the system, using an IO value of 0 to indicate output.

```
nDevices = audiodevinfo(0)
```

```
nDevices =
```

```
3
```

This example shows three output devices, but your system might vary.

Check Support for Input Device

Check if the input audio device identified by the ID value, 0, supports a sample rate of 44100 hertz, with 16 bits per sample, and two channels.

```
support = audiodevinfo(1,0,44100,16,2)
```

```
support =
```

```
1
```

audiodevinfo

The input device supports the specified sample rate, number of bits and number of channels.

See Also

[audioplayer](#) | [audiorecorder](#)

Purpose Create object for playing audio

Syntax

```
player = audioplayer(Y,Fs)
player = audioplayer(Y,Fs,nBits)
player = audioplayer(Y,Fs,nBits,ID)
player = audioplayer(recorder)
player = audioplayer(recorder,ID)
```

Description

`player = audioplayer(Y,Fs)` creates an `audioplayer` object for signal `Y`, using sample rate `Fs`. The function returns a handle to the `audioplayer` object, `player`.

`player = audioplayer(Y,Fs,nBits)` uses `nBits` bits per sample for signal `Y`.

`player = audioplayer(Y,Fs,nBits,ID)` uses the audio device identified by `ID` for output.

`player = audioplayer(recorder)` creates an `audioplayer` object using audio recorder object `recorder`.

`player = audioplayer(recorder , ID)` creates an object from `recorder` that uses the audio device identified by `ID` for output.

Input Arguments

Y

Audio signal represented by a vector or two-dimensional array containing `single`, `double`, `int8`, `uint8`, or `int16` values.

The value range of the input sample depends on the data type. The following table lists these ranges.

Data Type	Sample Value Range
<code>int8</code>	-128 to 127
<code>uint8</code>	0 to 255
<code>int16</code>	-32768 to 32767

audioplayer

Data Type	Sample Value Range
single	-1 to 1
double	-1 to 1

F_s

Sampling rate in Hz. Valid values depend on the specific audio hardware installed. Typical values supported by most sound cards are 8000, 11025, 22050, 44100, 48000, and 96000 Hz.

nBits

Bits per sample. Specify only when signal Y is represented by floating-point values. Valid values depend on the audio hardware installed: 8, 16, or 24.

Default: 16

ID

Device identifier. To obtain the ID of a device, use the `audiodevinfo` function.

Default: -1 (default device)

recorder

Audio recorder object created by `audiorecorder`.

Methods

Note When calling any method, include the `audioplayer` object name using function syntax, such as `stop(player)`.

<code>get</code>	Query properties of <code>audioplayer</code> object.
<code>isplaying</code>	Query whether playback is in progress: returns true or false.

<code>pause</code>	Pause playback.
<code>play</code>	Play audio from beginning to end.
<code>playblocking</code>	Play, and do not return control until playback completes.
<code>resume</code>	Restart playback from paused position.
<code>set</code>	Set properties of <code>audioplayer</code> object.
<code>stop</code>	Stop playback.

See the reference pages for `get`, `play`, `playblocking`, and `set` for additional syntax options.

Properties

<code>BitsPerSample</code>	Number of bits per sample. (Read-only)
<code>CurrentSample</code>	Current sample that the audio output device is playing. If the device is not playing, <code>CurrentSample</code> is the next sample to play with <code>play</code> or <code>resume</code> . (Read-only)
<code>DeviceID</code>	Identifier for audio device. (Read-only)
<code>NumberOfChannels</code>	Number of audio channels. (Read-only)
<code>Running</code>	Status of the audio player: 'on' or 'off'. (Read-only)
<code>SampleRate</code>	Sampling frequency in Hz.
<code>TotalSamples</code>	Total length of the audio data in samples. (Read-only)
<code>Tag</code>	String that labels the object.
<code>Type</code>	Name of the class: 'audioplayer'. (Read-only)
<code>UserData</code>	Any type of additional data to store with the object.

The following four properties apply to callback functions. The first two inputs to your callback function must be the `audioplayer` object and an *event* structure.

audioplayer

StartFcn	Function to execute one time when playback starts.
StopFcn	Function to execute one time when playback stops.
TimerFcn	Function to execute repeatedly during playback. To specify time intervals for the repetitions, use the <code>TimerPeriod</code> property.
TimerPeriod	Time in seconds between <code>TimerFcn</code> callbacks. Default: <code>.05</code>

Examples

Load and play a sample audio file of Handel’s “Hallelujah Chorus:”

```
load handel;  
player = audioplayer(y, Fs);  
play(player);
```

See Also

[audiodevinfo](#) | [audiorecorder](#) | [sound](#)

How To

- “Characteristics of Audio Files”
- “Play Audio”

Purpose

Create object for recording audio

Syntax

```
recorder = audiorecorder  
recorder = audiorecorder(Fs,nBits,nChannels)  
recorder = audiorecorder(Fs,nBits,nChannels,ID)
```

Description

`recorder = audiorecorder` creates an 8000 Hz, 8-bit, 1-channel `audiorecorder` object.

`recorder = audiorecorder(Fs,nBits,nChannels)` sets the sample rate `Fs` (in Hz), the sample size `nBits`, and the number of channels `nChannels`.

`recorder = audiorecorder(Fs,nBits,nChannels,ID)` sets the audio input device to the device specified by `ID`.

Tips

- To use an `audiorecorder` object, your system must have a properly installed and configured sound card.
- `audiorecorder` is not intended for long, high-sample-rate recording. `audiorecorder` uses system memory for storage and does not use disk buffering. When you attempt a large recording, your MATLAB performance sometimes degrades over time.

Input Arguments

Fs

Sampling rate in Hz. Valid values depend on the specific audio hardware installed. Typical values supported by most sound cards are 8000, 11025, 22050, 44100, 48000, and 96000 Hz.

Default: 8000

nBits

Bits per sample. Valid values depend on the audio hardware installed: 8, 16, or 24.

Default: 8

audiorecorder

nChannels

The number of channels: 1 (mono) or 2 (stereo).

Default: 1

ID

Device identifier. To obtain the ID of a device, use the `audiodevinfo` function.

Default: -1 (default device)

Methods

Note When calling any method, include the `audiorecorder` object name using function syntax, such as `stop(recorder)`.

<code>get</code>	Query properties of <code>audiorecorder</code> object.
<code>getaudiodata</code>	Create an array that stores the recorded signal values.
<code>getplayer</code>	Create an <code>audioplayer</code> object.
<code>isrecording</code>	Query whether recording is in progress: returns <code>true</code> or <code>false</code> .
<code>pause</code>	Pause recording.
<code>play</code>	Play recorded audio. This method returns an <code>audioplayer</code> object.
<code>record</code>	Start recording.
<code>recordblocking</code>	Record, and do not return control until recording completes. This method requires a second input for the length of the recording in seconds: <code>recordblocking(recorder, length)</code>
<code>resume</code>	Restart recording from paused position.
<code>set</code>	Set properties of <code>audiorecorder</code> object.
<code>stop</code>	Stop recording.

See the reference pages for `get`, `getaudiodata`, `play`, `record`, `recordblocking`, and `set` for additional syntax options.

Properties

<code>BitsPerSample</code>	Number of bits per sample. (Read-only)
<code>CurrentSample</code>	Current sample that the audio input device is recording. If the device is not recording, <code>CurrentSample</code> is the next sample to record with <code>record</code> or <code>resume</code> . (Read-only)
<code>DeviceID</code>	Identifier for audio device. (Read-only)
<code>NumberOfChannels</code>	Number of audio channels. (Read-only)
<code>Running</code>	Status of the audio recorder: 'on' or 'off'. (Read-only)
<code>SampleRate</code>	Sampling frequency in Hz. (Read-only)
<code>TotalSamples</code>	Total length of the audio data in samples. (Read-only)
<code>Tag</code>	String that labels the object.
<code>Type</code>	Name of the class: 'audiorecorder'. (Read-only)
<code>UserData</code>	Any type of additional data to store with the object.

The following four properties apply to callback functions. The first two inputs to your callback function must be the `audiorecorder` object and an *event* structure.

<code>StartFcn</code>	Function to execute one time when recording starts.
<code>StopFcn</code>	Function to execute one time when recording stops.

audiorecorder

TimerFcn	Function to execute repeatedly during recording. To specify time intervals for the repetitions, use the TimerPeriod property.
TimerPeriod	Time in seconds between TimerFcn callbacks. Default: .05

audiorecorder ignores any specified values for these properties, which will be removed in a future release.

BufferLength	Length of buffer in seconds.
NumberOfBuffers	Number of buffers.

Examples

Create an audiorecorder object for CD-quality audio in stereo, and view its properties:

```
recObj = audiorecorder(44100, 16, 2);  
get(recObj)
```

Collect a sample of your speech with a microphone, and plot the signal data:

```
% Record your voice for 5 seconds.  
recObj = audiorecorder;  
disp('Start speaking.')
```

```
recordblocking(recObj, 5);  
disp('End of Recording.');
```

```
% Play back the recording.  
play(recObj);
```

```
% Store data in double-precision array.  
myRecording = getaudiodata(recObj);
```

```
% Plot the waveform.  
plot(myRecording);
```

See Also

[audiodevinfo](#) | [audioplayer](#) | [sound](#)

How To

- “Characteristics of Audio Files”
- “Record Audio”
- “Record or Play Audio within a Function”

aufinfo

Purpose Information about NeXT/SUN (.au) sound file

Note aufinfo will be removed in a future release. Use audioinfo instead.

Syntax `[m d] = aufinfo(aufile)`

Description `[m d] = aufinfo(aufile)` returns information about the contents of the AU sound file specified by the string `aufile`.

`m` is the string 'Sound (AU) file', if `filename` is an AU file. Otherwise, it contains an empty string ('').

`d` is a string that reports the number of samples in the file and the number of channels of audio data. If `filename` is not an AU file, it contains the string 'Not an AU file'.

See Also `audioread` | `audioinfo`

Purpose Read NeXT/SUN (.au) sound file

Note auread will be removed in a future release. Use audioread instead.

Syntax

```
y = auread(aufile)
[y,Fs] = auread(aufile)
[y,Fs,nbits] = auread(aufile)
[ ___ ] = auread(aufile,N)
[ ___ ] = auread(aufile,[N1 N2])
siz = auread(aufile,'size')
```

Description `y = auread(aufile)` loads a sound file specified by the string `aufile`, returning the sampled data in `y`. The `.au` extension is appended if no extension is given. Amplitude values are in the range `[-1,+1]`. `auread` supports multichannel data in the following formats:

- 8-bit mu-law
- 8-, 16-, and 32-bit linear
- Floating-point

`[y,Fs] = auread(aufile)` returns the sample rate (`Fs`) in Hertz used to encode the data in the file.

`[y,Fs,nbits] = auread(aufile)` returns the number of bits per sample (`nbits`).

`[___] = auread(aufile,N)` returns only the first `N` samples from each channel in the file.

`[___] = auread(aufile,[N1 N2])` returns only samples `N1` through `N2` from each channel in the file.

`siz = auread(aufile,'size')` returns the size of the audio data contained in the file in place of the actual audio data, returning the vector `siz = [samples channels]`.

Examples

Create a sound file from the example file `handel.mat`, and read portions of the file back into MATLAB:

```
% Create .au file in current folder.
load handel.mat

hfile = 'handel.au';
auwrite(y, Fs, hfile)
clear y Fs

% Read the data back into MATLAB, and listen to audio.
[y, Fs, nbits] = auread(hfile);
sound(y, Fs);

% Pause before next read and playback operation.
duration = numel(y) / Fs;
pause(duration + 2)

% Read and play only the first 2 seconds.
nsamples = 2 * Fs;
[y2, Fs] = auread(hfile, nsamples);
sound(y2, Fs);
pause(4)

% Read and play the middle third of the file.
sizeinfo = auread(hfile, 'size');

tot_samples = sizeinfo(1);
startpos = tot_samples / 3;
endpos = 2 * startpos;

[y3, Fs] = auread(hfile, [startpos endpos]);
sound(y3, Fs);
```

See Also

[audiowrite](#) | [audioinfo](#) | [audioplayer](#) | [audiorecorder](#) | [sound](#) | [audioread](#)

Purpose Write NeXT/SUN (.au) sound file

Note auwrite will be removed in a future release.

Syntax

```
auwrite(y, aufile)
auwrite(y, Fs, aufile)
auwrite(y, Fs, N, aufile)
auwrite(y, Fs, N, method, aufile)
```

Description `auwrite(y, aufile)` writes a sound file specified by the string *aufile*. The data should be arranged with one channel per column. Amplitude values outside the range $[-1, +1]$ are clipped prior to writing. `auwrite` supports multichannel data for 8-bit mu-law and 8- and 16-bit linear formats.

`auwrite(y, Fs, aufile)` specifies the sample rate of the data in Hertz.

`auwrite(y, Fs, N, aufile)` selects the number of bits in the encoder. Allowable settings are $N = 8$ and $N = 16$.

`auwrite(y, Fs, N, method, aufile)` allows selection of the encoding method, which can be either 'mu' or 'linear'. Note that mu-law files must be 8-bit. By default, *method* = 'mu'.

See Also audioread | audiowrite

avifile

Purpose

Create new Audio/Video Interleaved (AVI) file

Note `avifile` will be removed in a future release. Use `VideoWriter` instead.

Syntax

```
aviobj = avifile(filename)  
avifile(filename, ParameterName, ParameterValue)
```

Description

`aviobj = avifile(filename)` creates an `avifile` object, giving it the name specified in `filename`, using default values for all `avifile` object properties. If `filename` does not include an extension, `avifile` appends `.avi` to the file name. AVI is a file format for storing audio and video data.

`avifile` returns a handle to an AVI file object `aviobj`. Use this object to refer to the AVI file in other functions. An AVI file object supports properties and methods that control aspects of the AVI file created.

`aviobj = avifile(filename, ParameterName, ParameterValue)` accepts one or more comma-separated parameter name/value pairs. Set parameter values before any calls to `addframe`. The following table lists the available parameters and values.

Parameter Name	Value	Default
'colormap'	An m -by-3 matrix defining the colormap for indexed AVI movies, where m is no more than 256 (236 for Indeo compression). Valid only when the 'compression' is 'MSVC', 'RLE', or 'None'.	No default
'compression'	A text string specifying the compression codec to use. To create an uncompressed file, specify a value of 'None'.	'Indeo5' on Windows systems.

Parameter Name	Value	Default
	<p>On UNIX[®] operating systems, the only valid value is 'None'.</p> <p>On Windows systems, valid values include:</p> <ul style="list-style-type: none"> • 'MSVC' • 'RLE' • 'Cinepak' on 32-bit systems. • 'Indeo3' or 'Indeo5' on 32-bit Windows XP systems. <p>Alternatively, specify a custom compression codec on Windows systems using the four-character code that identifies the codec (typically included in the codec documentation). If MATLAB cannot find the specified codec, it returns an error.</p>	'None' on UNIX systems.
'fps'	A scalar value specifying the speed of the AVI movie in frames per second (fps).	15 fps
'keyframe'	For compressors that support temporal compression, the number of key frames per second.	2.1429 key frames per second
'quality'	<p>A number from 0 through 100. Higher quality numbers result in higher video quality and larger file sizes. Lower quality numbers result in lower video quality and smaller file sizes.</p> <p>Valid only for compressed movies.</p>	75
'videoname'	A descriptive name for the video stream, no more than 64 characters.	<i>filename</i>

Tips

- On some Windows systems, including all 64-bit systems, the default Indeo® 5 codec is not available. MATLAB issues a warning, and creates an uncompressed file.
- On 32-bit Windows XP systems, MATLAB can create AVI files compressed with Indeo 3 and Indeo 5 codecs. However, Microsoft Windows XP Service Pack 3 (SP3) with Security Update 954157 disables playback of Indeo 3 and Indeo 5 codecs in Windows Media Player and Internet Explorer®. Consider specifying a compression value of 'None'.
- avifile cannot write files larger than 2 GB.
- You can use dot notation to set avifile object properties. For example, set the quality property to 100:

```
aviobj = avifile('myavifile');  
aviobj.quality = 100;
```

All property names of an avifile object are the same as the parameter names, except for the keyframe parameter, which corresponds to the KeyFramePerSec property. For example, change keyframe to 2.5:

```
aviobj.KeyFramePerSec = 2.5;
```

Examples

Create the AVI file example.avi:

```
aviobj = avifile('example.avi','compression','None');  
  
t = linspace(0,2.5*pi,40);  
fact = 10*sin(t);  
fig=figure;  
[x,y,z] = peaks;  
for k=1:length(fact)  
    h = surf(x,y,fact(k)*z);  
    axis([-3 3 -3 3 -80 80])  
    axis off  
    caxis([-90 90])  
end
```

```
F = getframe(fig);
aviobj = addframe(aviobj,F);
end
close(fig);
aviobj = close(aviobj);
```

Alternatives

Use VideoWriter rather than avifile to create AVI files. VideoWriter supports files larger than 2 GB, and by default, creates files with Motion JPEG compression, which all platforms support.

See Also

VideoWriter | addframe (avifile) | close (avifile) | movie2avi

Purpose

Information about Audio/Video Interleaved (AVI) file

Note `aviinfo` will be removed in a future release. Use `VideoReader` and the `get` method instead.

Syntax

```
fileinfo = aviinfo(filename)
```

Description

`fileinfo = aviinfo(filename)` returns a structure whose fields contain information about the AVI file specified in the string `filename`. If `filename` does not include an extension, then `.avi` is used. The file must be in the current working directory or in a directory on the MATLAB path.

The set of fields in the `fileinfo` structure is shown below.

Field Name	Description
AudioFormat	String containing the name of the format used to store the audio data, if audio data is present
AudioRate	Integer indicating the sample rate in Hertz of the audio stream, if audio data is present
Filename	String specifying the name of the file
FileModDate	String containing the modification date of the file
FileSize	Integer indicating the size of the file in bytes
FramesPerSecond	Integer indicating the desired frames per second
Height	Integer indicating the height of the AVI movie in pixels

Field Name	Description
ImageType	String indicating the type of image. Either 'truecolor' for a truecolor (RGB) image, or 'indexed' for an indexed image.
NumAudioChannels	Integer indicating the number of channels in the audio stream, if audio data is present
NumFrames	Integer indicating the total number of frames in the movie
NumColormapEntries	Integer specifying the number of colormap entries. For a truecolor image, this value is 0 (zero).
Quality	Number between 0 and 100 indicating the video quality in the AVI file. Higher quality numbers indicate higher video quality; lower quality numbers indicate lower video quality. This value is not always set in AVI files and therefore can be inaccurate.
VideoCompression	String containing the compressor used to compress the AVI file. If the compressor is not Microsoft Video 1, Run Length Encoding (RLE), Cinepak, or Intel® Indeo, aviinfo returns the four-character code that identifies the compressor.
Width	Integer indicating the width of the AVI movie in pixels

See also

mmfileinfo, VideoReader, VideoWriter

aviread

Purpose Read Audio/Video Interleaved (AVI) file

Note `aviread` will be removed in a future release. Use `VideoReader` instead.

Syntax

```
mov = aviread(filename)  
mov = aviread(filename, index)
```

Description `mov = aviread(filename)` reads the AVI movie *filename* into the MATLAB movie structure *mov*. If *filename* does not include an extension, then `.avi` is used. Use the `movie` function to view the movie *mov*. On UNIX platforms, *filename* must be an uncompressed AVI file. *mov* has two fields, `cdata` and `colormap`. The content of these fields varies depending on the type of image.

Image Type	cdata Field	colormap Field
Truecolor	Height-by-width-by-3 array of uint8 values	Empty
Indexed	Height-by-width array of uint8 values	m-by-3 array of double values

`aviread` supports 8-bit frames, for indexed and grayscale images, 16-bit grayscale images, or 24-bit truecolor images. Note, however, that `movie` only accepts 8-bit image frames; it does not accept 16-bit grayscale image frames.

`mov = aviread(filename, index)` reads only the frames specified by *index*. *index* can be a single index or an array of indices into the video stream. In AVI files, the first frame has the index value 1, the second frame has the index value 2, and so on.

See also `mmfileinfo`, `movie`, `VideoReader`, `VideoWriter`

Purpose Create axes graphics object

Syntax

```
axes  
axes('PropertyName',propertyvalue,...)  
axes(h)  
h = axes(...)
```

Properties For a list of properties, see Axes Properties.

Description `axes` creates an axes graphics object in the current figure using default property values. `axes` is the low-level function for creating axes graphics objects. MATLAB automatically creates an axes, if one does not already exist, when you issue a command that creates a graph.

`axes('PropertyName',propertyvalue,...)` creates an axes object having the specified property values. For a description of the properties, see Axes Properties. MATLAB uses default values for any properties that you do not explicitly define as arguments. The `axes` function accepts property name/property value pairs, structure arrays, and cell arrays as input arguments (see the `set` and `get` commands for examples of how to specify these data types). While the basic purpose of an axes object is to provide a coordinate system for plotted data, axes properties provide considerable control over the way MATLAB displays data.

`axes(h)` makes existing axes `h` the current axes and brings the figure containing it into focus. It also makes `h` the first axes listed in the figure's `Children` property and sets the figure's `CurrentAxes` property to `h`. The current axes is the target for functions that draw image, line, patch, rectangle, surface, and text graphics objects.

If you want to make an axes the current axes without changing the state of the parent figure, set the `CurrentAxes` property of the figure containing the axes:

```
set(figure_handle,'CurrentAxes',axes_handle)
```

This command is useful if you want a figure to remain minimized or stacked below other figures, but want to specify the current axes.

`h = axes(...)` returns the handle of the created axes object.

Use the `set` function to modify the properties of an existing axes or the `get` function to query the current values of axes properties. Use the `gca` command to obtain the handle of the current axes.

The `axis` (not `axes`) function provides simplified access to commonly used properties that control the scaling and appearance of axes.

Set default axes properties on the figure and root object levels:

```
set(0, 'DefaultAxesPropertyName', PropertyValue, ...)  
set(gcf, 'DefaultAxesPropertyName', PropertyValue, ...)
```

PropertyName is the name of the axes property and *PropertyValue* is the value you are specifying. Use `set` and `get` to access axes properties.

Stretch-to-Fill

By default, MATLAB stretches the axes to fill the axes position rectangle (the rectangle defined by the last two elements in the `Position` property). This results in graphs that use the available space in the rectangle. However, some 3-D graphs (such as a sphere) appear distorted because of this stretching, and are better viewed with a specific three-dimensional aspect ratio.

Stretch-to-fill is active when the `DataAspectRatioMode`, `PlotBoxAspectRatioMode`, and `CameraViewAngleMode` are all `auto` (the default). However, stretch-to-fill is turned off when the `DataAspectRatio`, `PlotBoxAspectRatio`, or `CameraViewAngle` is user-specified, or when one or more of the corresponding modes is set to `manual` (which happens automatically when you set the corresponding property value).

This picture shows the same sphere displayed both with and without the stretch-to-fill. The dotted lines show the axes rectangle.

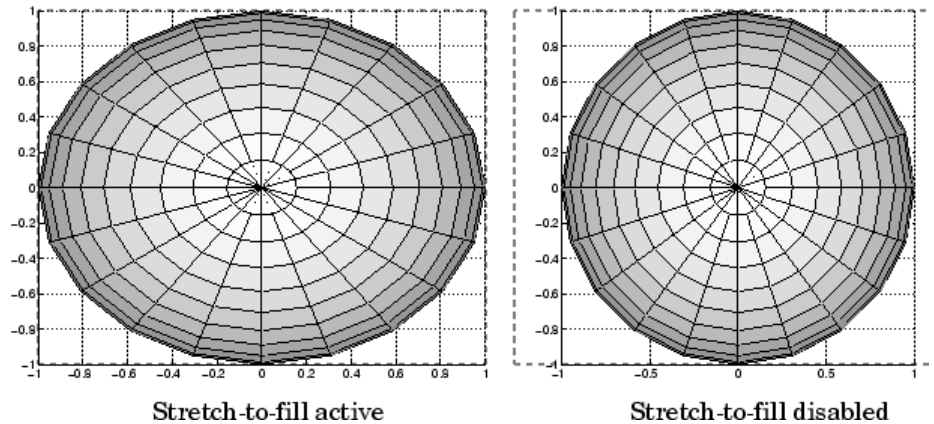

When stretch-to-fill is disabled, MATLAB sets the size of the axes to be as large as possible within the constraints imposed by the `Position` rectangle without introducing distortion. In the picture above, the height of the rectangle constrains the axes size.

Examples

Define Multiple Axes in Figure Window

Define multiple axes in a single figure window.

```
figure
axes('Position',[0.1,0.1,0.7,0.7])
contour(peaks(20))

axes('Position',[0.7,0.7,0.28,0.28])
surf(peaks(20))
```

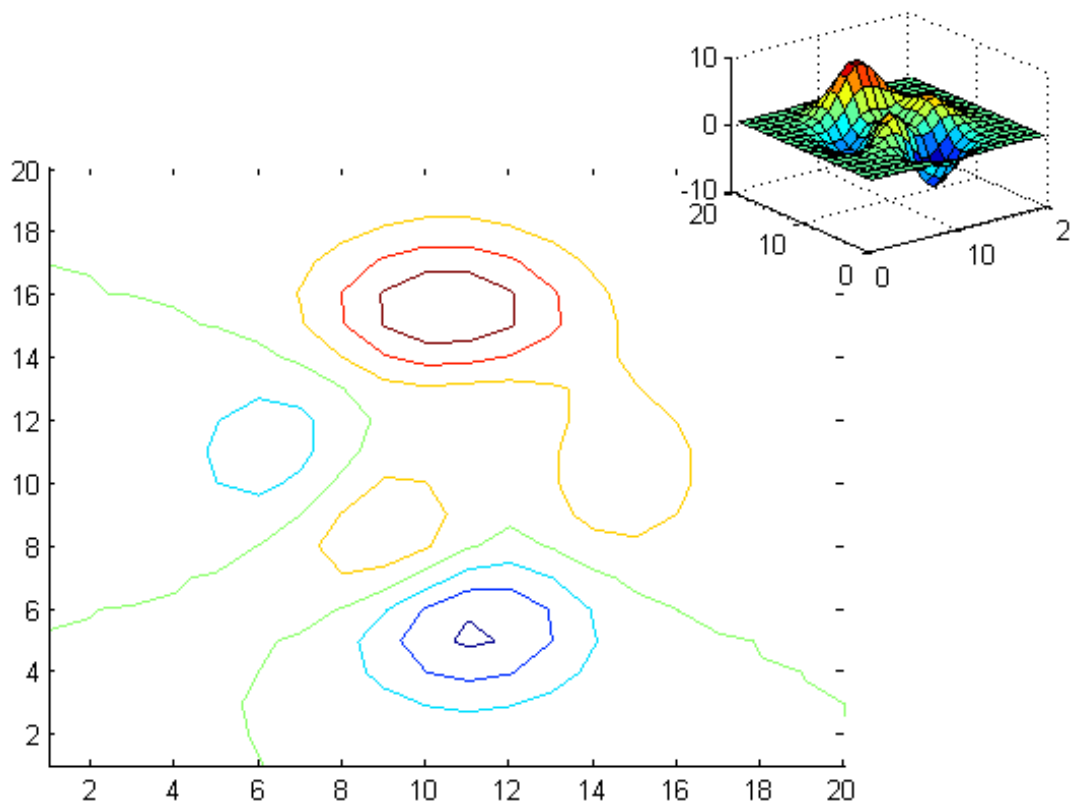

Alternatives

To create a figure select **New > Figure** from the figure window **File** menu. To add an axes to a figure, click one of the *New Subplots* icons in the Figure Palette, and slide right to select an arrangement of new axes. For details, see “Customize Graph Using Plot Tools”.

See Also

`axis` | `cla` | `clf` | `figure` | `gca` | `grid` | `subplot` | `title` | `xlabel` | `ylabel` | `zlabel` | `view` | Axes Properties

Tutorials

- “Axes Objects — Defining Coordinate Systems for Graphs”
- “Axes Property Operations”

Axes Properties

Purpose Modify axes properties

Creating Axes Objects Use axes to create axes objects.

Modifying Properties You can set and query graphics object properties in two ways:

- “Customize Objects in Graph” is an interactive tool that enables you to see and change object property values.
- The `set` and `get` commands let you set and query the values of properties.

To change the default values of properties, see “Setting Default Property Values” in the Handle Graphics Objects documentation.

Axes Property Descriptions This section provides a description of properties. Curly braces { } enclose default values.

`ActivePositionProperty`
{outerposition} | position

Use OuterPosition or Position property for resize. Specifies which property (`Position` or `OuterPosition`) MATLAB holds constant as you resize the figure (interactively or during a printing or exporting operation).

Setting a value for the `Position` property makes `position` the value of the `ActivePositionProperty`. The same is also true of setting a value for the `OuterPosition` property; `outerposition` becomes the value of the `ActivePositionProperty`.

See `OuterPosition` and `Position` for related properties.

See `Automatic Axes Resize` for a discussion of how to use axes positioning properties.

ALim

[amin, amax]

Alpha axis limits. Determines how MATLAB maps the AlphaData values of surface, patch, and image objects to the figure's alphamap.

- **amin** — Value of the data mapped to the first alpha value in the alphamap.
- **amax** — Value of the data mapped to the last alpha value in the alphamap.

MATLAB linearly interpolates data values in between across the alphamap and clamps data values outside to either the first or last alphamap value, whichever is closest.

If the axes contains multiple graphics objects, MATLAB sets ALim to span the range of all objects' AlphaData (or FaceVertexAlphaData for patch objects).

See the alpha function reference page for additional information.

ALimMode

{auto} | manual

Alpha axis limits mode.

- **auto** — MATLAB sets the ALim property to span the AlphaData limits of the graphics objects displayed in the axes.
- **manual** — MATLAB does not change the value of ALim when the AlphaData limits of axes children change.

Setting the ALim property sets ALimMode to manual.

AmbientLightColor

ColorSpec

Axes Properties

Background light in a scene. Ambient light is a directionless light that shines uniformly on all objects in the axes. However, if there are no visible light objects in the axes, MATLAB does not use `AmbientLightColor`. If there are light objects in the axes, MATLAB adds the `AmbientLightColor` to the other light sources.

`AspectRatio`
(Obsolete)

This property produces a warning message when queried or changed. The `DataAspectRatio[Mode]` and `PlotBoxAspectRatio[Mode]` properties have superseded it.

`BeingDeleted`
on | {off} (read-only)

This object is being deleted. Mechanism to determine if objects are in the process of being deleted. MATLAB sets the `BeingDeleted` property to `on` when the object's delete function callback is called (see the `DeleteFcn` property). It remains set to `on` while the delete function executes, after which the object no longer exists.

For example, an object's delete function calls other functions that act on a number of different objects. If a function does not need to perform an action on an about-be-deleted object, it can check the object's `BeingDeleted` property before acting.

See the `close` and `delete` function reference pages for related information.

`Box`
on | {off}

Axes box mode. Specifies whether to enclose the axes extent in a box for 2-D views or a cube for 3-D views. The default is to not display the box.

`BusyAction`
cancel | {queue}

Callback queuing

Determines how MATLAB handles the execution of interrupting callbacks.

A *running* callback is the currently executing callback. The *interrupting* callback is the callback that tries to interrupt the *running* callback. The `BusyAction` property of the *interrupting* callback determines how MATLAB handles its execution. When the `BusyAction` property is set to:

- 'queue' — Puts the *interrupting* callback in a queue to be processed after the *running* callback finishes execution.
- 'cancel' — Discards the *interrupting* callback as MATLAB finishes execution.

For information about how the `Interruptible` property of the callback controls whether other callbacks can interrupt the *running* callback, see the `Interruptible` property description.

`ButtonDownFcn`

function handle | cell array containing function handle and additional arguments | string (not recommended)

Button press callback function. Executes whenever you press a mouse button while the pointer is within the axes, but not over another graphics object parented to the axes. For 3-D views, the active area is a rectangle that encloses the axes.

See the figure's `SelectionType` property to determine whether modifier keys were also pressed.

Set this property to a function handle that references the callback. The function must define at least two input arguments (handle of axes associated with the button down event and an event structure, which is empty for this property).

Axes Properties

For information on the syntax of callback functions, see [Function Handle Callbacks](#).

Some Plotting Functions Reset the `ButtonDownFcn`

Most MATLAB plotting functions clear the axes and reset a number of axes properties, including the `ButtonDownFcn` before plotting data. To create an interface that lets users plot data interactively, consider using a control device such as a push button (`uicontrol`), which plotting functions do not affect.

If you must use the axes `ButtonDownFcn` to plot data, then you should use low-level functions such as `line`, `patch`, and `surface` and manage the process with the figure and axes `NextPlot` properties.

See “High-Level Versus Low-Level Functions” for information on how plotting functions behave.

See “Preparing Figures and Axes for Graphics” for more information.

Camera Properties

See [View Control with the Camera Toolbar](#) for information related to the Camera properties.

See [Defining Scenes with Camera Graphics](#) for information on the camera properties.

See [View Projection Types](#) for information on orthogonal and perspective projections.

`CameraPosition`

[*x*, *y*, *z*] axes coordinates

Location of the camera. Position from which the camera views the scene. Specify the point in axes coordinates.

If you fix `CameraViewAngle`, you can zoom in and out on the scene by changing the `CameraPosition`, moving the camera closer to the `CameraTarget` to zoom in and farther away from the `CameraTarget` to zoom out. As you change the `CameraPosition`, the amount of perspective also changes, if `Projection` is perspective. You can also zoom by changing the `CameraViewAngle`; however, this does not change the amount of perspective in the scene.

`CameraPositionMode`
{auto} | manual

Auto or manual CameraPosition. When set to `auto`, MATLAB automatically calculates the `CameraPosition` such that the camera lies a fixed distance from the `CameraTarget` along the azimuth and elevation specified by `view`. Setting a value for `CameraPosition` sets this property to `manual`.

`CameraTarget`
[x, y, z] axes coordinates

Camera aiming point. Specifies the location in the axes that the camera points to. The `CameraTarget` and the `CameraPosition` define the vector (the view axis) along which the camera looks.

`CameraTargetMode`
{auto} | manual

Auto or manual CameraTarget placement. When this property is `auto`, MATLAB automatically positions the `CameraTarget` at the centroid of the axes plot box. Specifying a value for `CameraTarget` sets this property to `manual`.

`CameraUpVector`
[x, y, z] axes coordinates

Camera rotation. Specifies the rotation of the camera around the viewing axis defined by the `CameraTarget` and the `CameraPosition` properties. Specify `CameraUpVector` as a

Axes Properties

three-element array containing the x , y , and z components of the vector. For example, $[0\ 1\ 0]$ specifies the positive y -axis as the up direction.

The default `CameraUpVector` is $[0\ 0\ 1]$, which defines the positive z -axis as the up direction.

`CameraUpVectorMode`
{auto} | manual

Default or user-specified up vector. When `CameraUpVectorMode` is `auto`, MATLAB uses a value of $[0\ 0\ 1]$ (positive z -direction is up) for 3-D views and $[0\ 1\ 0]$ (positive y -direction is up) for 2-D views. Setting a value for `CameraUpVector` sets this property to `manual`.

`CameraViewAngle`
scalar greater than 0 and less than or equal to 180 (angle in degrees)

Field of view. Determines the camera field of view. Changing this value affects the size of graphics objects displayed in the axes, but does not affect the degree of perspective distortion. The greater the angle, the larger the field of view, and the smaller objects appear in the scene.

`CameraViewAngleMode`
{auto} | manual

Auto or manual CameraViewAngle. When in `auto` mode, MATLAB sets `CameraViewAngle` to the minimum angle that captures the entire scene (up to 180°).

The following table summarizes MATLAB camera behavior using various combinations of `CameraViewAngleMode`, `CameraTargetMode`, and `CameraPositionMode`:

Axes Properties

CameraViewAngleMode	CameraTargetMode	CameraPositionMode	Behavior
auto	auto	auto	Sets CameraTarget to plot box centroid, sets CameraViewAngle to capture entire scene, sets CameraPosition along the view axis.
auto	auto	manual	Sets CameraTarget to plot box centroid, sets CameraViewAngle to capture entire scene.
auto	manual	auto	Sets CameraViewAngle to capture entire scene, sets CameraPosition along the view axis.
auto	manual	manual	Sets CameraViewAngle to capture entire scene.
manual	auto	auto	Sets CameraTarget to plot box centroid, sets CameraPosition along the view axis.
manual	auto	manual	Sets CameraTarget to plot box centroid.

Axes Properties

CameraViewAngleMode	CameraTargetMode	CameraPositionMode	Behavior
manual	manual	auto	Sets CameraPosition along the view axis.
manual	manual	manual	User specifies all camera properties.

Children

vector of graphics object handles

Handles of all graphics objects rendered within the axes (whether visible or not). The graphics objects that can be children of axes are `image`, `light`, `line`, `patch`, `rectangle`, `surface`, and `text`. Change the order of the handles to change the stacking of the objects on the display.

The text objects used to label the x -, y -, and z -axes and the title are also children of axes, but their `HandleVisibility` properties are set to `off`. This means their handles do not show up in the axes `Children` property unless you set the `Root ShowHiddenHandles` property to `on`.

When an object's `HandleVisibility` property is `off`, its parent's `Children` property does not list it. See `HandleVisibility` for more information.

CLim

[`cmin`, `cmax`]

Color axis limits. Determines how MATLAB maps the `CData` values of `surface` and `patch` objects to the figure's `Colormap`. `cmin` is the value of the data mapped to the first color in the `colormap`. `cmax` is the value of the data mapped to the last color in the `colormap`. MATLAB linearly interpolates data values in between across the `colormap` and clamps data values outside to either the first or last `colormap` color, whichever is closest.

When `CLimMode` is `auto` (the default), MATLAB assigns `cmin` the minimum data value and `cmax` the maximum data value in the graphics object's `CData`. This maps `CData` elements with minimum data value to the first `colormap` entry and with maximum data value to the last `colormap` entry.

If the axes contains multiple graphics objects, MATLAB sets `CLim` to span the range of all objects' `CData`.

See the `caxis` function reference page for related information.

`CLimMode`

`{auto} | manual`

Color axis limits mode.

- `auto` — MATLAB sets the `CLim` property to span the `CData` limits of the graphics objects displayed in the axes.
- `manual` — MATLAB does not change the value of `CLim` when the `CData` limits of axes children change.

Setting the `CLim` property sets this property to `manual`.

`Clipping`

`{on} | off`

Clipping mode. This property has no effect on axes.

`Color`

`{[1,1,1]} | ColorSpec`

Color of the axes back planes. Setting this property to `none` means that the axes is transparent and the figure color shows through. A `ColorSpec` is a three-element RGB vector or one of the MATLAB predefined names.

`ColorOrder`

`m-by-3` matrix of RGB values

Axes Properties

Colors to use for multiline plots. Defines the colors used by the `plot` and `plot3` functions to color each line plotted. If you do not specify a line color with `plot` and `plot3`, these functions cycle through the `ColorOrder` property to obtain the color for each line plotted. To obtain the current `ColorOrder`, which might be set during startup, get the property value:

```
get(gca, 'ColorOrder')
```

Note that if the axes `NextPlot` property is `replace` (the default), high-level functions like `plot` reset the `ColorOrder` property before determining the colors to use. If you want MATLAB to use a `ColorOrder` that is different from the default, set `NextPlot` to `replacechildren`. You can also specify your own default `ColorOrder`.

CreateFcn

function handle | cell array containing function handle and additional arguments | string (not recommended)

Callback function executed during object creation. Executes when MATLAB creates an axes object. You must define this property as a default value for axes. For example, the statement:

```
set(0, 'DefaultAxesCreateFcn', @ax_create)
```

defines a default value on the Root level that sets axes properties whenever you (or MATLAB) create an axes.

```
function ax_create(src, evnt)
    set(src, 'Color', 'b', ...
        'XLim', [1 10], ...
        'YLim', [0 100])
end
```

MATLAB executes this function after setting all properties for the axes. Setting the `CreateFcn` property on an existing axes object has no effect.

MATLAB passes the handle of the object whose `CreateFcn` is being executed as the first argument to the callback function and is also accessible through the `Root CallbackObject` property, which can be queried using `gcbo`.

For information on the syntax of callback functions, see [Function Handle Callbacks](#).

CurrentPoint
2-by-3 matrix

Location of last button click, in axes data units. Contains the coordinates of two points defined by the location of the pointer at the last mouse click. MATLAB returns the coordinates with respect to the requested axes.

Clicking Within the Axes — Orthogonal Projection

The two points lie on the line that is perpendicular to the plane of the screen and passes through the pointer. This is true for both 2-D and 3-D views.

The 3-D coordinates are the points, in the axes coordinate system, where this line intersects the front and back surfaces of the axes volume (which is defined by the axes x , y , and z limits).

The returned matrix is of the form:

$$\begin{bmatrix} x_{front} & y_{front} & z_{front} \\ x_{back} & y_{back} & z_{back} \end{bmatrix}$$

where *front* defines the point nearest to the camera position. Therefore, if the `CurrentPoint` property returns the `cp` matrix, then the first row,

`cp(1, :)`

specifies the point nearest the viewer and the second row,

`cp(2, :)`

specifies the point furthest from the viewer.

Clicking Outside the Axes — Orthogonal Projection

When you click outside the axes volume, but within the figure, the returned values are:

- Back point — a point in the plane of the camera target (which is perpendicular to the viewing axis).
- Front point — a point in the camera position plane (which is perpendicular to the viewing axis).

These points lie on a line that passes through the pointer and is perpendicular to the camera target and camera position planes.

Clicking Within the Axes — Perspective Projection

The values of the current point when using perspective project can be different from the same point in orthographic projection because the shape of the axes volume can be different.

Clicking Outside the Axes — Perspective Projection

Clicking outside of the axes volume returns the front point as the current camera position at all times. Only the back point updates with the coordinates of a point that lies on a line extending from the camera position through the pointer and intersecting the camera target at the point.

Related Information

See the figure `CurrentPoint` property for more information.

DataAspectRatio
[dx dy dz]

Relative scaling of data units. Controls the relative scaling of data units in the x , y , and z directions. For example, setting this property to [1 2 1] causes the length of one unit of data in the x -direction to be the same length as two units of data in the y -direction and one unit of data in the z -direction.

Note that the DataAspectRatio property interacts with the PlotBoxAspectRatio, XLimMode, YLimMode, and ZLimMode properties to control how MATLAB scales the x -, y -, and z -axis. Setting the DataAspectRatio disables the stretch-to-fill behavior if DataAspectRatioMode, PlotBoxAspectRatioMode, and CameraViewAngleMode are all auto.

The following table describes the interaction between properties when you disable stretch-to-fill behavior.

Interaction Between Properties With Stretch-to-Fill Disabled

X-, Y-, Z-LimitModes	DataAspectRatio	PlotBoxAspectRatio	Behavior
auto	auto	auto	Limits chosen to span data range in all dimensions.
auto	auto	manual	Limits chosen to span data range in all dimensions. MATLAB modifies DataAspectRatio to achieve the requested PlotBoxAspectRatio

Axes Properties

X-, Y-, Z-LimitModes	DataAspectRatio	PlotBoxAspectRatio	Behavior
			within the limits the software selected.
auto	manual	auto	Limits chosen to span data range in all dimensions. MATLAB modifies <code>PlotBoxAspectRatio</code> to achieve the requested <code>DataAspectRatio</code> within the limits the software selected.
auto	manual	manual	Limits chosen to completely fit and center the plot within the requested <code>PlotBoxAspectRatio</code> given the requested <code>DataAspectRatio</code> (this might produce empty space around 2 of the 3 dimensions).
manual	auto	auto	MATLAB honors limits and modifies the <code>DataAspectRatio</code> and <code>PlotBoxAspectRatio</code> as necessary.

X-, Y-, Z-LimitModes	DataAspectRatio	PlotBoxAspectRatio	Behavior
manual	auto	manual	MATLAB honors limits and <code>PlotBoxAspectRatio</code> and modifies <code>DataAspectRatio</code> as necessary.
manual	manual	auto	MATLAB honors limits and <code>DataAspectRatio</code> and modifies the <code>PlotBoxAspectRatio</code> as necessary.
1 manual 2 auto	manual	manual	MATLAB selects the 2 automatic limits to honor the specified aspect ratios and limit. See "Examples."
2 or 3 manual	manual	manual	MATLAB honors limits and <code>DataAspectRatio</code> while ignoring <code>PlotBoxAspectRatio</code> .

See “Understanding Axes Aspect Ratio” for more information.

`DataAspectRatioMode`
{auto} | manual

User or MATLAB controlled data scaling. Controls whether the values of the `DataAspectRatio` property are user-defined or selected automatically by MATLAB. Setting values for the `DataAspectRatio` property automatically sets this property

Axes Properties

to manual. Changing `DataAspectRatioMode` to manual disables the stretch-to-fill behavior if `DataAspectRatioMode`, `PlotBoxAspectRatioMode`, and `CameraViewAngleMode` are all auto.

DeleteFcn

function handle | cell array containing function handle and additional arguments | string (not recommended)

Delete axes callback function. Executes when you delete the axes object (for example, when you issue a `delete` or `clf` command). MATLAB executes the routine before destroying the object's properties so the callback can query these values.

MATLAB passes the handle of the object whose `DeleteFcn` is executing as the first argument to the callback function. The handle is also accessible through the `Root CallbackObject` property, which can be queried using `gcbo`.

For information on the syntax of callback functions, see [Function Handle Callbacks](#).

DrawMode

{normal} | fast

Rendering mode. Controls the way MATLAB renders graphics objects displayed in the axes when the figure `Renderer` property is `painters`.

- `normal` — Draws objects in back to front ordering based on the current view in order to handle hidden surface elimination and object intersections.
- `fast` — Draws objects in the order in which you specify the drawing commands, without considering the relationships of the objects in three dimensions. This results in faster rendering because it requires no sorting of objects according to location in the view, but can produce undesirable results because it

bypasses the hidden surface elimination and object intersection handling provided by `normal` `DrawMode`.

When the figure `Renderer` property is `zbuffer`, MATLAB ignores `DrawMode` and always provides hidden surface elimination and object intersection handling.

FontAngle

`{normal} | italic | oblique`

Select italic or normal font. Selects the character slant for axes text. `normal` specifies a nonitalic font. `italic` and `oblique` specify italic font.

FontName

`name (such as Courier) | FixedWidth`

Font family name. Specifies the font to use for axes labels. To display and print properly, `FontName` must be a font that your system supports. Note that MATLAB does not display the x -, y -, and z -axis labels in a new font until you manually reset them (by setting the `XLabel`, `YLabel`, and `ZLabel` properties or by using the `xlabel`, `ylabel`, or `zlabel` command). Tick mark labels change immediately.

Specifying a Fixed-Width Font

If you want an axes to use a fixed-width font that looks good in any locale, set `FontName` to the string `FixedWidth`:

```
set(axes_handle, 'FontName', 'FixedWidth')
```

This eliminates the need to hardcode the name of a fixed-width font, which might not display text properly on systems that do not use ASCII character encoding (such as in Japan, where character sets can be multibyte). A properly written MATLAB application that needs to use a fixed-width font should set `FontName` to `FixedWidth` (note that this string is case sensitive) and rely

Axes Properties

on `FixedWidthFontName` to be set correctly in the end user's environment.

End users can adapt a MATLAB application to different locales or personal environments by setting the root `FixedWidthFontName` property to the appropriate value for that locale from `startup.m`.

Note that setting the root `FixedWidthFontName` property causes an immediate update of the display to use the new font.

FontSize

Font size specified in `FontUnits`

Font size. An integer specifying the font size to use for axes labels and titles, in units determined by the `FontUnits` property. The default point size is 12 and the maximum allowable font size depends on your operating system. MATLAB does not display *x*-, *y*-, and *z*-axis text labels in a new font size until you manually reset them (by setting the `XLabel`, `YLabel`, or `ZLabel` properties or by using the `xlabel`, `ylabel`, or `zlabel` command). Tick mark labels change immediately.

FontUnits

{points} | normalized | inches | centimeters | pixels

Units used to interpret the FontSize property. When set to `normalized`, MATLAB interprets the value of `FontSize` as a fraction of the height of the axes. For example, a `normalized FontSize` of 0.1 sets the text characters to a font whose height is one tenth of the axes' height. The default units (`points`), are equal to 1/72 of an inch.

If you set both the `FontSize` and the `FontUnits` in one function call, you must set the `FontUnits` property first so that MATLAB correctly interprets the specified `FontSize`.

FontWeight

{normal} | bold | light | demi

Select bold or normal font. The character weight for axes text. MATLAB does not display the x -, y -, and z -axis text labels in bold until you manually reset them (by setting the `XLabel`, `YLabel`, and `ZLabel` properties or by using the `xlabel`, `ylabel`, or `zlabel` commands). Tick mark labels change immediately.

GridLineStyle

- | -- | {:} | -. | none

Line style used to draw grid lines. The line style is a string consisting of a character, in quotes, specifying solid lines (-), dashed lines (--), dotted lines(:), or dash-dot lines (-.). The default grid line style is dotted. To turn on grid lines, use the `grid` command.

HandleVisibility

{on} | callback | off

Control access to object's handle. Determines when an object's handle is visible in its parent's list of children. `HandleVisibility` is useful for preventing command-line users from accidentally drawing into or deleting a figure that contains only user interface devices (such as a dialog box).

- `on` — Handles are always visible.
- `callback` — Handles are visible from within callback routines or functions invoked by callback routines, but not from within functions invoked from the command line. This provides a means to protect GUIs from command-line users, while allowing callback routines to have access to object handles.
- `off` — Handles are invisible at all times. Use this option when a callback invokes a function that could damage the GUI (such as evaluating a user-typed string). This option temporarily hides its own handles during the execution of that function.

When a handle is not visible in its parent's list of children, functions that obtain handles by searching the object hierarchy or

Axes Properties

querying handle properties cannot return it. This includes `get`, `findobj`, `gca`, `gcf`, `gco`, `newplot`, `cla`, `clf`, and `close`.

When you restrict a handle's visibility by using `callback` or `off`, the object's handle does not appear in its parent's `Children` property, figures do not appear in the Root's `CurrentFigure` property, objects do not appear in the Root's `CallbackObject` property or in the figure's `CurrentObject` property, and axes do not appear in their parent's `CurrentAxes` property.

You can set the Root `ShowHiddenHandles` property to `on` to make all handles visible regardless of their `HandleVisibility` settings (this does not affect the values of the `HandleVisibility` properties).

Handles that are hidden are still valid. If you know an object's handle, you can `set` and `get` its properties, and pass it to any function that operates on handles.

`HitTest`
`{on} | off`

Selectable by mouse click. Determines if the axes can become the current object (as returned by the `gco` command and the figure `CurrentObject` property) as a result of a mouse click the axes. If `HitTest` is `off`, clicking the axes selects the object below it (which is usually the figure containing it).

`Interruptible`
`off | {on}`

Callback routine interruption

Controls whether MATLAB can interrupt an object's callback function when subsequent callbacks attempt to interrupt it.

For Graphics objects, the `Interruptible` property affects only the callbacks for the `ButtonDownFcn` property. A *running* callback is

the currently executing callback. The *interrupting* callback is the callback that tries to interrupt the *running* callback. MATLAB handles both the callbacks based on the `Interruptible` property of the object of the *running* callback.

When the `Interruptible` property is set to:

- 'off', MATLAB finishes execution of the *running* callback without any interruptions
- 'on', these conditions apply:
 - If there is a `drawnow`, `figure`, `getframe`, `waitfor`, or `pause` command in the *running* callback, then MATLAB executes the *interrupting* callbacks which are already in the queue and returns to finish execution of the current callback.
 - If one of the above functions is not in the *running* callback, then MATLAB finishes execution of the current callback without any interruption.

`BusyAction` property of the object of interrupting callback determines whether the callback should be ignored or should be put in the queue.

Setting `Interruptible` property to `on` (default), allows a callback from other graphics objects to interrupt callback functions originating from this object.

Note MATLAB does not save the state of properties or the display when an interruption occurs. For example, the handle returned by the `gca` or `gcf` command may be changed as another callback is executed.

After the function that interrupts a callback completes, the callback resumes execution where it halted when interrupted.

Axes Properties

For more information, see “Control Callback Execution and Interruption”.

Layer

{bottom} | top

Draw axis lines below or above graphics objects. Determines whether to draw axis lines and tick marks on top or below axes children objects for any 2-D view (for example, when you are looking along the x -, y -, or z -axis). Use this property to place grid lines and tick marks on top of images.

LineStyleOrder

LineStyleSpec {a solid line '-'} }

Order of line styles and markers used in a plot. Specifies which line styles and markers to use and in what order when creating multiple-line plots. For example:

```
set(gca, 'LineStyleOrder', '-*|:|o')
```

sets `LineStyleOrder` to solid line with asterisk marker, dotted line, and hollow circle marker. The default is (-), which specifies a solid line for all data plotted. Alternatively, you can create a cell array of character strings to define the line styles:

```
set(gca, 'LineStyleOrder', {'-*', ':', 'o'})
```

MATLAB supports four line styles, which you can specify any number of times in any order. MATLAB cycles through the line styles only after using all colors defined by the `ColorOrder` property. For example, the first eight lines plotted use the different colors defined by `ColorOrder` with the first line style. MATLAB then cycles through the colors again, using the second line style specified, and so on.

You can also specify line style and color directly with the `plot` and `plot3` functions or by altering the properties of the `line` or `lineseries` objects after creating the graph.

High-Level Functions and LineStyleOrder

Note that, if the axes `NextPlot` property is `replace` (the default), high-level functions like `plot` reset the `LineStyleOrder` property before determining the line style to use. If you want MATLAB to use a `LineStyleOrder` that is different from the default, set `NextPlot` to `replacechildren`.

Specifying a Default LineStyleOrder

You can specify your own default `LineStyleOrder`. For example:

```
set(0, 'DefaultAxesLineStyleOrder', {'-*', ':', 'o'})
```

creates a default value for the axes `LineStyleOrder` that high-level plotting functions will not reset.

LineWidth

line width in points

Width of axis lines. Specifies the width, in points, of the x -, y -, and z -axis lines. The default line width is 0.5 points 1 point = $1/72$ inch.

MinorGridLineStyle

- | -- | {:} | -. | none

Line style used to draw minor grid lines. The line style is a string consisting of one or more characters, in quotes, specifying solid lines (-), dashed lines (--), dotted lines (:{), or dash-dot lines (-.). The default minor grid line style is dotted. To turn on minor grid lines, use the `grid minor` command.

NextPlot

add | {replace} | replacechildren

Where to draw the next plot. Determines how high-level plotting functions draw into an existing axes.

- `add` — Use the existing axes to draw graphics objects.

Axes Properties

- `replace` — Reset all axes properties except `Position` to their defaults and delete all axes children before displaying graphics (equivalent to `cla reset`).
- `replacechildren` — Remove all child objects, but do not reset axes properties (equivalent to `cla`).

The `newplot` function simplifies the use of the `NextPlot` property and is useful for functions that draw graphs using only low-level object creation routines. Note that figure graphics objects also have a `NextPlot` property.

`OuterPosition`
four-element vector

Position of axes including labels, title, and a margin. Specifies a rectangle that locates the outer bounds of the axes, including axis labels, the title, and a margin. The vector is as follows:

[left bottom width height]

where `left` and `bottom` define the distance from the lower-left corner of the figure window to the lower-left corner of the rectangle. `width` and `height` are the dimensions of the rectangle.

The following picture shows the region defined by the `OuterPosition` enclosed in a yellow rectangle.

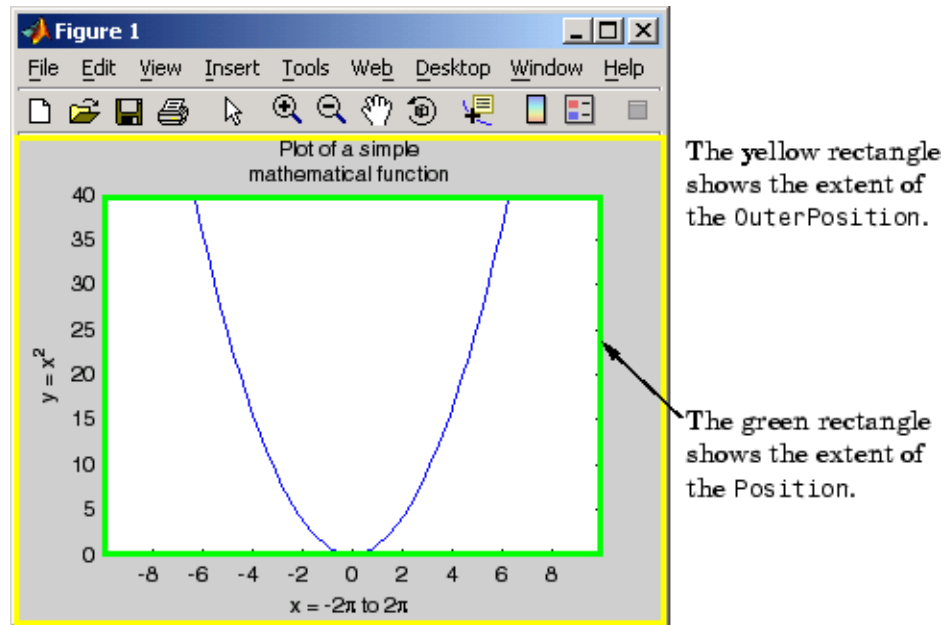

When `ActivePositionProperty` is `OuterPosition` (the default), resizing the figure will not clip any of the text. The default value of `[0 0 1 1]` (normalized units) includes the interior of the figure.

The `Units` property specifies all measurement units.

See the property for related information.

See “Automatic Axes Resize” for a discussion of how to use axes positioning properties.

Parent

figure or uipanel handle

Axes parent. The handle of the axes’ parent object. The parent of an axes object is the figure which displays it or the uipanel object that contains it. The utility function `gcf` returns the handle of

Axes Properties

the current axes Parent. You can reparent axes to other figure or uipanel objects.

`PlotBoxAspectRatio`
[px py pz]

Relative scaling of axes plot box. Controls the relative scaling of the plot box in the x , y , and z directions. The plot box is a box enclosing the axes data region as defined by the x -, y -, and z -axis limits.

Note that the `PlotBoxAspectRatio` property interacts with the `DataAspectRatio`, `XLimMode`, `YLimMode`, and `ZLimMode` properties to control the way MATLAB displays graphics objects. Setting the `PlotBoxAspectRatio` disables stretch-to-fill behavior, if `DataAspectRatioMode`, `PlotBoxAspectRatioMode`, and `CameraViewAngleMode` are all auto.

`PlotBoxAspectRatioMode`
{auto} | manual

User or MATLAB controlled axis scaling. Controls whether the values of the `PlotBoxAspectRatio` property are user-defined or selected automatically by MATLAB. Setting values for the `PlotBoxAspectRatio` property automatically sets this property to manual. Changing the `PlotBoxAspectRatioMode` to manual disables stretch-to-fill behavior if `DataAspectRatioMode`, `PlotBoxAspectRatioMode`, and `CameraViewAngleMode` are all auto.

`Position`
four-element vector

Position of axes. Specifies a rectangle that locates the axes within its parent container (figure or uipanel). The vector is of the form:

[left bottom width height]

where `left` and `bottom` define the distance from the lower-left corner of the container to the lower-left corner of the rectangle. `width` and `height` are the dimensions of the rectangle. The `Units` property specifies the units for all measurements.

When you enable axes stretch-to-fill behavior (when `DataAspectRatioMode`, `PlotBoxAspectRatioMode`, and `CameraViewAngleMode` are all `auto`), MATLAB stretches the axes to fill the `Position` rectangle. When you disable stretch-to-fill, MATLAB makes the axes as large as possible, while obeying all other properties, without extending outside the `Position` rectangle.

See the `OuterPosition` property for related information.

See “Automatic Axes Resize” for a discussion of how to use axes positioning properties.

Projection

`{orthographic} | perspective`

Type of projection. Selects one of the following projection types:

- `orthographic` — Maintains the correct relative dimensions of graphics objects regarding the distance a given point is from the viewer and draws parallel lines in the data parallel on the screen.
- `perspective` — Incorporates foreshortening, which allows you to perceive depth in 2-D representations of 3-D objects. Perspective projection does not preserve the relative dimensions of objects; it displays a distant line segment smaller than a nearer line segment of the same length. Parallel lines in the data might not appear parallel on screen.

Selected

`on | {off}`

Axes Properties

Is object selected? When you set this property to on, MATLAB displays selection “handles” at the corners and midpoints if the `SelectionHighlight` property is also on (the default). You can, for example, define the `ButtonDownFcn` callback to set this property to on, thereby indicating that the axes has been selected.

`SelectionHighlight`
{on} | off

Highlights objects when selected. When the `Selected` property is on, MATLAB indicates the selected state by drawing four edge handles and four corner handles. When `SelectionHighlight` is off, MATLAB does not draw the handles.

`Tag`
string

User-specified object label. Provides a means to identify graphics objects with a user-specified label. The default is an empty string.

Use the `Tag` property and the `findobj` function to manipulate specific objects within a plotting hierarchy.

For example, suppose you want to direct all graphics output from a file to a particular axes, regardless of user actions that might have changed the current axes. To do this, identify the axes with a `Tag`:

```
axes('Tag','Special Axes')
```

Then make that axes the current axes before drawing by searching for the `Tag` with `findobj`:

```
axes(findobj('Tag','Special Axes'))
```

`TickDir`
in | out

Direction of tick marks. For 2-D views, the default is to direct tick marks inward from the axis lines; 3-D views direct tick marks outward from the axis line.

TickDirMode
{auto} | manual

Automatic tick direction control. In auto mode, MATLAB directs tick marks inward for 2-D views and outward for 3-D views. When you specify a setting for TickDir, MATLAB sets TickDirMode to manual. In manual mode, MATLAB does not change the specified tick direction.

TickLength
[2DLength 3DLength]

Length of tick marks. Specifies the length of axes tick marks. The first element is the length of tick marks used for 2-D views and the second element is the length of tick marks used for 3-D views. Specify tick mark lengths in units normalized relative to the longest of the visible x -, y -, or z -axis annotation lines.

TightInset
[left bottom right top] Read only

Margins added to Position to include text labels. The distances between the bounds of the Position property and the extent of the axes text labels and title. When added to the Position width and height values, the TightInset defines the tightest bounding box that encloses the axes and its labels and title.

See “Automatic Axes Resize” for more information.

Title
handle of text object

Axes title. The handle of the text object used for the axes title. Use this handle to change the properties of the title text or you can

Axes Properties

set `Title` to the handle of an existing text object. For example, the following statement changes the color of the current title to red:

```
set(get(gca,'Title'),'Color','r')
```

To create a new title, set this property to the handle of the text object you want to use:

```
set(gca,'Title',text('String','New Title'),'Color','r')
```

However, it is simpler to use the `title` command to create or replace an axes title:

```
title('New Title','Color','r') % Make text color red  
title({'This title','has 2 lines'}) % Two line title
```

Type

string (read-only)

Type of graphics object. String that identifies the class of the graphics object. Use this property to find all objects of a given type within a plotting hierarchy. For axes objects, `Type` is always 'axes'.

UIContextMenu

handle of uicontextmenu object

Associate a context menu with the axes. Assign this property the handle of a `uicontextmenu` object created in the axes' parent figure. Use the `uicontextmenu` function to create the context menu. MATLAB displays the context menu whenever you right-click over the axes.

Units

inches | centimeters | {normalized} | points | pixels
| characters

Axes position units. The units used to interpret the `Position` property. MATLAB measures all units from the lower left corner of the figure window.

Note The `Units` property controls the positioning of the axes within the figure. This property does not affect the data units used for graphing. See the axes `XLim`, `YLim`, and `ZLim` properties to set the limits of each axis data units.

- `normalized` — Units map the lower left corner of the figure window to (0,0) and the upper right corner to (1.0, 1.0).
- `inches`, `centimeters`, and `points` — Absolute units. 1 point = $\frac{1}{72}$ inch.
- `characters` — Based on the size of characters in the default system font. The width of one `characters` unit is the width of the letter x, and the height of one `characters` unit is the distance between the baselines of two lines of text.

When specifying the units as property/value pairs during object creation, you must set the `Units` property before specifying the properties that you want to use these units.

`UserData`
matrix

User-specified data. Data you want to associate with the axes object. The default value is an empty array. MATLAB does not use this data, but you can access it using the `set` and `get` commands.

`View`
Obsolete

The axes camera properties now controls the functionality provided by the `View` property — `CameraPosition`, `CameraTarget`, `CameraUpVector`, and `CameraViewAngle`. See the `view` command.

Axes Properties

Visible

{on} | off

Visibility of axes. By default, axes are visible. Setting this property to `off` prevents axis lines, tick marks, and labels from being displayed. The `Visible` property does not affect children of axes.

XAxisLocation

top | {bottom}

Location of x-axis tick marks and labels. Controls where MATLAB displays the *x*-axis tick marks and labels. Setting this property to `top` moves the *x*-axis to the top of the plot from its default position at the bottom. This property applies to 2-D views only.

YAxisLocation

right | {left}

Location of y-axis tick marks and labels. Controls where MATLAB displays the *y*-axis tick marks and labels. Setting this property to `right` moves the *y*-axis to the right side of the plot from its default position on the left side. This property applies to 2-D views only. See the `plotyy` function for a simple way to use two *y*-axes.

Properties That Control the X-, Y-, or Z-Axis

XColor

YColor

ZColor

ColorSpec

Color of axis lines. A three-element vector specifying an RGB triple, or a predefined MATLAB color string. This property determines the color of the axis lines, tick marks, tick mark labels, and the axis grid lines of the respective *x*-, *y*-, and *z*-axis. The default axis color is black. See `ColorSpec` for details on specifying colors.

XDir
YDir
ZDir
{normal} | reverse

Direction of increasing values. A mode controlling the direction of increasing axis values. Axes form a right-hand coordinate system. By default:

- x -axis values increase from left to right. To reverse the direction of increasing x values, set this property to reverse.

```
set(gca, 'XDir', 'reverse')
```

- y -axis values increase from bottom to top (2-D view) or front to back (3-D view). To reverse the direction of increasing y values, set this property to reverse.

```
set(gca, 'YDir', 'reverse')
```

- z -axis values increase pointing out of the screen (2-D view) or from bottom to top (3-D view). To reverse the direction of increasing z values, set this property to reverse.

```
set(gca, 'ZDir', 'reverse')
```

XGrid
YGrid
ZGrid
on | {off}

Axis gridline mode. When you set any of these properties to on, MATLAB draws grid lines perpendicular to the respective axis (for example, along lines of constant x , y , or z values). Use the `grid` command to set all three properties on or off at once.

```
set(gca, 'XGrid', 'on')
```

Axes Properties

XLabel

YLabel

ZLabel

handle of text object

Axis labels. The handle of the `text` object used to label the x -, y -, or z -axis, respectively. To assign values to any of these properties, you must obtain the handle to the text string you want to use as a label. This statement defines a text object and assigns its handle to the XLabel property:

```
set(get(gca,'XLabel'),'String','axis label')
```

MATLAB places the string 'axis label' appropriately for an x -axis label and moves any text object whose handle you specify as an XLabel, YLabel, or ZLabel property to the appropriate location for the respective label.

Alternatively, you can use the `xlabel`, `ylabel`, and `zlabel` functions, which generally provide a simpler means to label axis lines.

Note that using a bitmapped font (for example, Courier is usually a bitmapped font) might cause the labels to rotate improperly. As a workaround, use a TrueType font (for example, Courier New) for axis labels. See your system documentation to determine the types of fonts installed on your system.

XLim

YLim

ZLim

[minimum maximum]

Axis limits. Specifies the minimum and maximum values of the respective axis. The data you plot determines these values.

Changing these properties affects the scale of the x -, y -, or z -dimension as well as the placement of labels and tick marks on the axis. The default values for these properties are [0 1].

See the `axis`, `datetick`, `xlim`, `ylim`, and `zlim` commands to set these properties.

`XLimMode`
`YLimMode`
`ZLimMode`
 {auto} | manual

MATLAB or user-controlled limits. The axis limits mode determines whether MATLAB calculates axis limits based on the data plotted (for example, the `XData`, `YData`, or `ZData` of the axes children) or uses the values explicitly set with the `XLim`, `YLim`, or `ZLim` property, in which case, the respective limits mode is set to manual.

`XMinorGrid`
`YMinorGrid`
`ZMinorGrid`
 on | {off}

Enable or disable minor gridlines. When set to on, MATLAB draws gridlines aligned with the minor tick marks of the respective axis. Note that you do not have to enable minor ticks to display minor grids.

`XMinorTick`
`YMinorTick`
`ZMinorTick`
 on | {off}

Enable or disable minor tick marks. When set to on, MATLAB draws tick marks between the major tick marks of the respective axis. MATLAB automatically determines the number of minor ticks based on the space between the major ticks.

Axes Properties

XScale
YScale
ZScale
 {linear} | log

Axis scaling. Linear or logarithmic scaling for the respective axis. See also `loglog`, `semilogx`, and `semilogy`.

XTick
YTick
ZTick
 vector of data values locating tick marks

Tick spacing. A vector of x -, y -, or z -data values that determine the location of tick marks along the respective axis. If you do not want tick marks displayed, set the respective property to the empty vector, `[]`. These vectors must contain monotonically increasing values.

XTickLabel
YTickLabel
ZTickLabel
 string

Tick labels. A matrix of strings to use as labels for tick marks along the respective axis. These labels replace the numeric labels generated by MATLAB. If you do not specify enough text labels for all the tick marks, MATLAB uses all of the labels specified, then reuses the specified labels.

For example, the statement:

```
set(gca, 'XTickLabel', {'One'; 'Two'; 'Three'; 'Four'})
```

labels the first four tick marks on the x -axis and then reuses the labels for the remaining ticks.

Labels can be cell arrays of strings, padded string matrices, string vectors separated by vertical slash characters, or numeric vectors (where MATLAB implicitly converts each number to the equivalent string using `num2str`). All of the following are equivalent:

```
set(gca,'XTickLabel',{'1';'10';'100'})
set(gca,'XTickLabel','1|10|100')
set(gca,'XTickLabel',[1;10;100])
set(gca,'XTickLabel',['1 ','10 ','100'])
```

Note that tick labels do not interpret TeX character sequences (however, the `Title`, `XLabel`, `YLabel`, and `ZLabel` properties do).

```
XTickMode
YTickMode
ZTickMode
    {auto} | manual
```

MATLAB or user-controlled tick spacing. The axis tick modes determine whether MATLAB calculates the tick mark spacing based on the range of data for the respective axis (auto mode) or uses the values explicitly set for any of the `XTick`, `YTick`, and `ZTick` properties (manual mode). Setting values for the `XTick`, `YTick`, or `ZTick` properties sets the respective axis tick mode to manual.

```
XTickLabelMode
YTickLabelMode
ZTickLabelMode
    {auto} | manual
```

MATLAB or user-determined tick labels. The axis tick mark labeling modes determine whether MATLAB uses numeric tick mark labels that span the range of the plotted data (auto mode) or uses the tick mark labels specified with the `XTickLabel`, `YTickLabel`, or `ZTickLabel` property (manual mode). Setting

Axes Properties

values for the `XTickLabel`, `YTickLabel`, or `ZTickLabel` property sets the respective axis tick label mode to manual.

See Also `axes`

Purpose

Axis scaling and appearance

Syntax

```
axis([xmin xmax ymin ymax])
axis([xmin xmax ymin ymax zmin zmax cmin cmax])
v = axis
axis auto
axis manual
axis tight
axis fill
axis ij
axis xy
axis equal
axis image
axis square
axis vis3d
axis normal
axis off
axis on
axis(axes_handles,...)
[mode,visibility,direction] = axis('state')
```

Description

`axis` manipulates commonly used axes properties. (See Algorithm section.)

`axis([xmin xmax ymin ymax])` sets the limits for the x - and y -axis of the current axes.

`axis([xmin xmax ymin ymax zmin zmax cmin cmax])` sets the x -, y -, and z -axis limits and the color scaling limits (see `caxis`) of the current axes.

`v = axis` returns a row vector containing scaling factors for the x -, y -, and z -axis. `v` has four or six components depending on whether the current axes is 2-D or 3-D, respectively. The returned values are the current axes `XLim`, `Ylim`, and `ZLim` properties.

`axis auto` sets MATLAB default behavior to compute the current axes limits automatically, based on the minimum and maximum values of x , y , and z data. You can restrict this automatic behavior to a specific

`axis`. For example, `axis 'auto x'` computes only the x -axis limits automatically; `axis 'auto yz'` computes the y - and z -axis limits automatically.

`axis manual` and `axis(axis)` freezes the scaling at the current limits, so that if `hold` is on, subsequent plots use the same limits. This sets the `XLimMode`, `YLimMode`, and `ZLimMode` properties to `manual`.

`axis tight` sets the axis limits to the range of the data.

`axis fill` sets the axis limits and `PlotBoxAspectRatio` so that the axes fill the position rectangle. This option has an effect only if `PlotBoxAspectRatioMode` or `DataAspectRatioMode` is `manual`.

`axis ij` places the coordinate system origin in the upper left corner. The i -axis is vertical, with values increasing from top to bottom. The j -axis is horizontal with values increasing from left to right.

`axis xy` draws the graph in the default Cartesian axes format with the coordinate system origin in the lower left corner. The x -axis is horizontal with values increasing from left to right. The y -axis is vertical with values increasing from bottom to top.

`axis equal` sets the aspect ratio so that the data units are the same in every direction. The aspect ratio of the x -, y -, and z -axis is adjusted automatically according to the range of data units in the x , y , and z directions.

`axis image` is the same as `axis equal` except that the plot box fits tightly around the data.

`axis square` makes the current axes region square (or cubed when three-dimensional). This option adjusts the x -axis, y -axis, and z -axis so that they have equal lengths and adjusts the increments between data units accordingly.

`axis vis3d` freezes aspect ratio properties to enable rotation of 3-D objects and overrides `stretch-to-fill`.

`axis normal` automatically adjusts the aspect ratio of the axes and the relative scaling of the data units so that the plot fits the figure's shape as well as possible.

`axis off` turns off all axis lines, tick marks, and labels.

`axis on` turns on all axis lines, tick marks, and labels.

`axis(axes_handles,...)` applies the axis command to the specified axes. For example, the following statements

```
h1 = subplot(221);
h2 = subplot(222);
axis([h1 h2], 'square')
```

set both axes to square.

`[mode,visibility,direction] = axis('state')` returns three strings indicating the current setting of axes properties:

Output Argument	Strings Returned
mode	'auto' 'manual'
visibility	'on' 'off'
direction	'xy' 'ij'

mode is auto if `XLimMode`, `YLimMode`, and `ZLimMode` are all set to auto. If `XLimMode`, `YLimMode`, or `ZLimMode` is manual, mode is manual.

Keywords to `axis` can be combined, separated by a space (e.g., `axis tight equal`). These are evaluated from left to right, so subsequent keywords can overwrite properties set by prior ones.

Tips

You can create an axes (and a figure for it) if none exists with the `axis` command. However, if you specify non-default limits or formatting for the axes when doing this, such as `[4 8 2 9]`, `square`, `equal`, or `image`, the property is ignored because there are no axis limits to adjust in the absence of plotted data. To use `axis` in this manner, you can set `hold on` to keep preset axes limits from being overridden.

Examples

Set Axis Limits

Plot the tan function from 0 to $\pi/2$.

```
x = 0:.01:pi/2;  
y = tan(x);
```

```
figure  
plot(x,y,'-o')
```

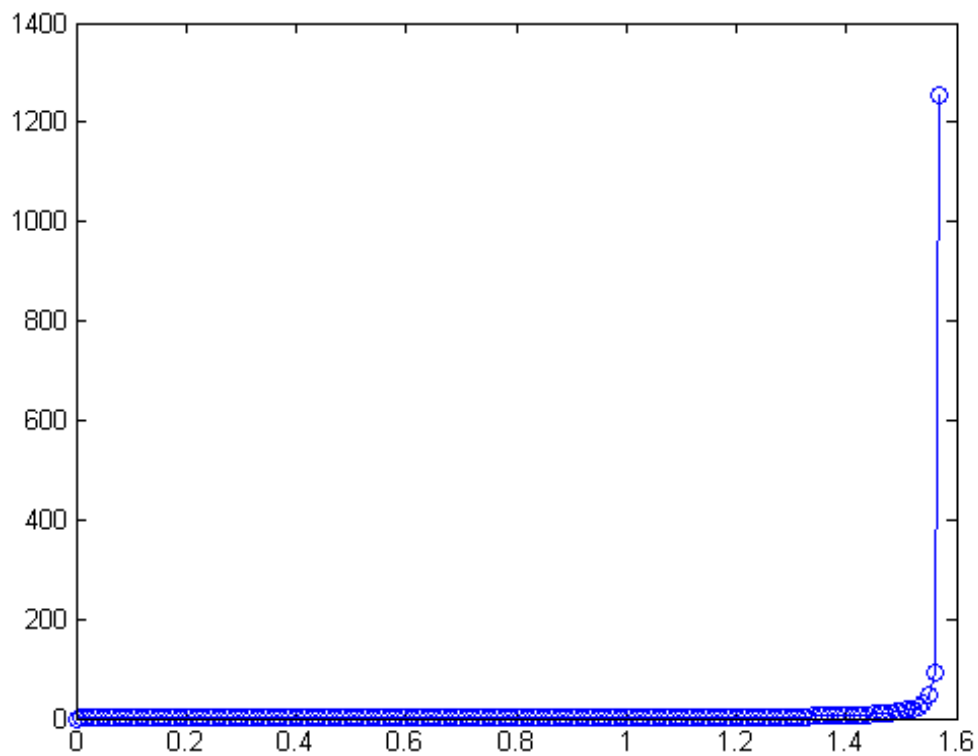

Change the axis limits so that the x -axis ranges from 0 to $\pi/2$ and the y -axis ranges from 0 to 5.

```
axis([0,pi/2,0,5])
```

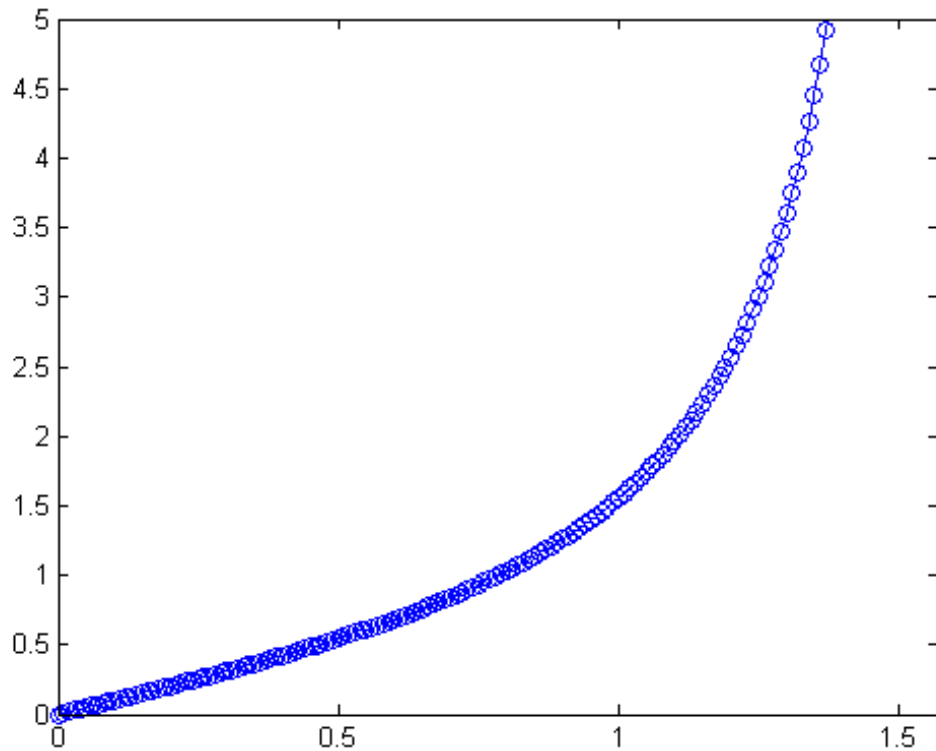

Algorithms

When you specify minimum and maximum values for the x -, y -, and z -axes, `axis` sets the `XLim`, `Ylim`, and `ZLim` properties for the current axes to the respective minimum and maximum values in the argument

list. Additionally, the `XLimMode`, `YLimMode`, and `ZLimMode` properties for the current axes are set to `manual`.

`axis auto` sets the current axes `XLimMode`, `YLimMode`, and `ZLimMode` properties to `'auto'`.

`axis manual` sets the current axes `XLimMode`, `YLimMode`, and `ZLimMode` properties to `'manual'`.

The following table shows the values of the axes properties set by `axis equal`, `axis normal`, `axis square`, and `axis image`.

Axes Property or Behavior	axis equal	axis normal	axis square	axis image
DataAspectRatio property	[1 1 1]	not set	not set	[1 1 1]
DataAspectRatioMode property	manual	auto	auto	manual
PlotBoxAspectRatio property	[3 4 4]	not set	[1 1 1]	auto
PlotBoxAspectRatioMode property	manual	auto	manual	auto
<i>Stretch-to-fill</i> behavior;	disabled	active	disabled	disabled

See Also

[axes](#) | [grid](#) | [subplot](#) | [xlim](#) | [ylim](#) | [zlim](#) | [axes properties](#)

Purpose

Diagonal scaling to improve eigenvalue accuracy

Syntax

```
[T,B] = balance(A)
[S,P,B] = balance(A)
B = balance(A)
B = balance(A, 'noperm')
```

Description

`[T,B] = balance(A)` returns a similarity transformation T such that $B = T \backslash A * T$, and B has, as nearly as possible, approximately equal row and column norms. T is a permutation of a diagonal matrix whose elements are integer powers of two to prevent the introduction of roundoff error. If A is symmetric, then $B == A$ and T is the identity matrix.

`[S,P,B] = balance(A)` returns the scaling vector S and the permutation vector P separately. The transformation T and balanced matrix B are obtained from A , S , and P by $T(:,P) = \text{diag}(S)$ and $B(P,P) = \text{diag}(1./S) * A * \text{diag}(S)$.

`B = balance(A)` returns just the balanced matrix B .

`B = balance(A, 'noperm')` scales A without permuting its rows and columns.

Tips

-

Nonsymmetric matrices can have poorly conditioned eigenvalues. Small perturbations in the matrix, such as roundoff errors, can lead to large perturbations in the eigenvalues. The condition number of the eigenvector matrix,

$$\text{cond}(V) = \text{norm}(V) * \text{norm}(\text{inv}(V))$$

where

$$[V,T] = \text{eig}(A)$$

balance

relates the size of the matrix perturbation to the size of the eigenvalue perturbation. Note that the condition number of A itself is irrelevant to the eigenvalue problem.

Balancing is an attempt to concentrate any ill conditioning of the eigenvector matrix into a diagonal scaling. Balancing usually cannot turn a nonsymmetric matrix into a symmetric matrix; it only attempts to make the norm of each row equal to the norm of the corresponding column.

Note The MATLAB eigenvalue function, `eig(A)`, automatically balances A before computing its eigenvalues. Turn off the balancing with `eig(A, 'nobalance')`.

Examples

This example shows the basic idea. The matrix A has large elements in the upper right and small elements in the lower left. It is far from being symmetric.

```
A = [1 100 10000; .01 1 100; .0001 .01 1]
A =
  1.0e+04 *
  0.0001    0.0100    1.0000
  0.0000    0.0001    0.0100
  0.0000    0.0000    0.0001
```

Balancing produces a diagonal matrix T with elements that are powers of two and a balanced matrix B that is closer to symmetric than A .

```
[T,B] = balance(A)
T =
  1.0e+03 *
  2.0480         0         0
         0    0.0320         0
         0         0    0.0003
B =
  1.0000    1.5625    1.2207
```

```

0.6400    1.0000    0.7813
0.8192    1.2800    1.0000

```

To see the effect on eigenvectors, first compute the eigenvectors of A, shown here as the columns of V.

```

[V,E] = eig(A); V
V =
0.9999          -0.9999          -0.9999
0.0100          0.0059 + 0.0085i    0.0059 - 0.0085i
0.0001          0.0000 - 0.0001i    0.0000 + 0.0001i

```

Note that all three vectors have the first component the largest. This indicates V is badly conditioned; in fact $\text{cond}(V)$ is $8.7766e+003$. Next, look at the eigenvectors of B.

```

[V,E] = eig(B); V
V =
0.6933          -0.6993          -0.6993
0.4437          0.2619 + 0.3825i    0.2619 - 0.3825i
0.5679          0.2376 - 0.4896i    0.2376 + 0.4896i

```

Now the eigenvectors are well behaved and $\text{cond}(V)$ is 1.4421. The ill conditioning is concentrated in the scaling matrix; $\text{cond}(T)$ is 8192.

This example is small and not really badly scaled, so the computed eigenvalues of A and B agree within roundoff error; balancing has little effect on the computed results.

Limitations

Balancing can destroy the properties of certain matrices; use it with some care. If a matrix contains small elements that are due to roundoff error, balancing might scale them up to make them as significant as the other elements of the original matrix.

See Also

`eig`

bandwidth

Purpose Lower and upper matrix bandwidth

Syntax `B = bandwidth(A,type)`

`[lower,upper] = bandwidth(A)`

Description `B = bandwidth(A,type)` returns the bandwidth of matrix `A` specified by type. Specify type as 'lower' for the lower bandwidth, or 'upper' for the upper bandwidth.

`[lower,upper] = bandwidth(A)` returns the lower bandwidth, lower, and upper bandwidth, upper, of matrix `A`.

Input Arguments

A - Input matrix
2-D numeric matrix

Input matrix, specified as a 2-D numeric matrix. `A` can be either full or sparse.

Data Types

single | double

Complex Number Support: Yes

type - Bandwidth type

'lower' | 'upper'

Bandwidth type, specified as 'lower' or 'upper'.

- Specify 'lower' for the lower bandwidth. The lower bandwidth is the number of nonzero diagonals below the main diagonal.
- Specify 'upper' for the upper bandwidth. The upper bandwidth is the number of nonzero diagonals above the main diagonal.

Data Types

char

Output Arguments**B - Lower or upper bandwidth**

nonnegative integer scalar

Lower or upper bandwidth, returned as a nonnegative integer scalar.

- If type is 'lower', then B is the number of nonzero diagonals below the main diagonal and $0 \leq B \leq \text{size}(A,1) - 1$.
- If type is 'upper', then B is the number of nonzero diagonals above the main diagonal and $0 \leq B \leq \text{size}(A,2) - 1$.

lower - Lower bandwidth

nonnegative integer scalar

Lower bandwidth, returned as a nonnegative integer scalar. The lower bandwidth is the number of nonzero diagonals below the main diagonal. lower is in the range $0 \leq \text{lower} \leq \text{size}(A,1) - 1$.

upper - Upper bandwidth

nonnegative integer scalar

Upper bandwidth, returned as a nonnegative integer scalar. The upper bandwidth is the number of nonzero diagonals above the main diagonal. upper is in the range $0 \leq \text{upper} \leq \text{size}(A,2) - 1$.

Examples**Find Bandwidth of Triangular Matrix**

Create a 6-by-6 lower triangular matrix.

```
A = tril(magic(6))
```

```
A =
```

```

35     0     0     0     0     0
 3    32     0     0     0     0
31     9     2     0     0     0
 8    28    33    17     0     0
30     5    34    12    14     0
 4    36    29    13    18    11
```

bandwidth

Find the lower bandwidth of A by specifying type as 'lower'.

```
B = bandwidth(A, 'lower')
```

```
B =
```

```
5
```

The result is 5 because every diagonal below the main diagonal has nonzero elements.

Find the upper bandwidth of A by specifying type as 'upper'.

```
B = bandwidth(A, 'upper')
```

```
B =
```

```
0
```

The result is 0 because there are no nonzero elements above the main diagonal.

Find Bandwidth of Sparse Block Matrix

Create a 100-by-100 sparse block matrix.

```
B = kron(speye(25), ones(4));
```

View a 10-by-10 section of elements from the top left of B.

```
full(B(1:10, 1:10))
```

```
ans =
```

```
1 1 1 1 0 0 0 0 0 0
1 1 1 1 0 0 0 0 0 0
1 1 1 1 0 0 0 0 0 0
1 1 1 1 0 0 0 0 0 0
0 0 0 0 1 1 1 1 0 0
0 0 0 0 1 1 1 1 0 0
```

```
0 0 0 0 1 1 1 1 0 0
0 0 0 0 1 1 1 1 0 0
0 0 0 0 0 0 0 0 1 1
0 0 0 0 0 0 0 0 1 1
```

B has 4-by-4 blocks of ones centered on the main diagonal.

Find both the lower and upper bandwidths of B by specifying two output arguments.

```
[lower,upper] = bandwidth(B)
```

```
lower =
```

```
3
```

```
upper =
```

```
3
```

The lower and upper bandwidths are both 3.

Bandwidth

The upper and lower bandwidths of a matrix are the number of nonzero diagonals above and below the main diagonal, respectively.

In terms of the upper and lower bandwidths, the total bandwidth of the matrix is equal to `upper + lower + 1`.

Tips

- Use the `isbanded` function to test if a matrix is within a specific lower and upper bandwidth.

See Also

`isbanded` | `isdiag` | `istriu` | `istril` | `diag`

bar

Purpose Bar graph

Syntax

```
bar(Y)
bar(x,Y)

bar( __ ,width)
bar( __ ,style)
bar( __ ,bar_color)
bar( __ ,Name,Value)

bar(axes_handle, __ )

h = bar( __ )
```

Description `bar(Y)` draws one bar for each element in `Y`.

`bar(x,Y)` draws bars for each column in `Y` at locations specified in `x`.

`bar(__ ,width)` sets the relative bar width and controls the separation of bars within a group and can include any of the input arguments in previous syntaxes.

`bar(__ ,style)` specifies the style of the bars and can include any of the input arguments in previous syntaxes.

`bar(__ ,bar_color)` displays all bars using the color specified by the single-letter abbreviation of `bar_color` and can include any of the input arguments in previous syntaxes.

`bar(__ ,Name,Value)` sets the property names to the specified values and can include any of the input arguments in previous syntaxes.

Note You cannot specify names and values when using `hist` or `histc` options.

`bar(axes_handle, ___)` plots into the axes with the handle `axes_handle` instead of into the current axes (`gca`).

`h = bar(___)` returns a vector of handles to `barseries` graphics objects, one for each created.

Change the colormap to use a different color scheme. Use the `colormap` function to specify the figure colormap.

Use shading `flat` to turn off bar edges. Use shading `faceted` to turn on bar edges. See the `shading` function for more information.

Input Arguments

x - x-axis intervals

vector | 2-D array

x-axis intervals for vertical bars, specified as a vector or a 2-D array..

The *x*-values can be nonmonotonic, but cannot contain duplicate values.

Example: `x = 1:10;`

Data Types

single | double | int8 | int16 | int32 | int64 | uint8 | uint16 | uint32 | uint64

Y - Bar lengths

vector | 2-D array

Bar lengths, specified as a vector or a 2-D array.

- If *Y* is a vector, then `bar` creates `length(Y)` bars. The `bar` function treats all vectors as column vectors.
- If *Y* is a 2-D array, then `bar` groups the bars produced by the elements in each row.

bar

- If Y is complex, then `bar(Y)` plots the imaginary parts of Y versus the index of each entry. If either x or Y is complex, then `bar(x,Y)` ignores the imaginary parts and plots the real parts of Y versus the real parts of x .

Example: `y = [10,8,5,7,3,9,1];`

Data Types

`single` | `double` | `int8` | `int16` | `int32` | `int64` | `uint8` |
`uint16` | `uint32` | `uint64`

width - Bar width

`0.8` (default) | `scalar`

Bar width of each bar, specified as a fraction of the total width of a bar and the space between bars. The default of 0.8 means the a bar width is 80% of the space from the previous bar to the next bar, with 10% of that space on each side.

If width is 1, the bars within a group touch one another.

Example: `bar(y,0.5);`

Data Types

`single` | `double` | `int8` | `int16` | `int32` | `int64` | `uint8` |
`uint16` | `uint32` | `uint64`

style - Bar style, specified as one of the following strings

`'grouped'` (default) | `'stacked'` | `'hist'` | `'histc'`

Bar style, specified by one of these values.

Style	Purpose
'grouped'	<p data-bbox="911 317 1317 378">Displays one group for each row in Y.</p> <ul data-bbox="911 413 1332 713" style="list-style-type: none"><li data-bbox="911 413 1332 569">• If Y is an m-by-n matrix, then MATLAB displays m groups of n vertical bars, where m is the number of rows and n is the number of columns in Y.<li data-bbox="911 586 1332 713">• If Y is a vector of length n, then MATLAB treats Y as a column vector and displays one group of n bars.
'stacked'	<p data-bbox="911 734 1317 795">Displays one bar for each row in Y.</p> <ul data-bbox="911 817 1332 1211" style="list-style-type: none"><li data-bbox="911 817 1332 1098">• If Y is an m-by-n matrix, then MATLAB displays m bars where each bar height is the sum of the elements in the row. Each bar is multicolored. Colors correspond to distinct elements and show the relative contribution each row element makes to the total sum.<li data-bbox="911 1116 1332 1211">• If Y is a vector of length n, then MATLAB treats Y as a column vector and displays n bars.

bar

Style	Purpose
'histc'	Displays the graph in histogram format, in which bars touch one another.
'hist'	Displays the graph in histogram format, but centers each bar over the <i>x</i> -ticks, rather than making bars span <i>x</i> -ticks as the <code>histc</code> option does.

Example: `bar(Y, 'hist')`

Data Types

char

bar_color - Bar color

'b' | 'r' | 'g' | 'b' | 'c' | 'm' | 'y' | 'k' | 'w'

Bar color, specified as a single-letter abbreviation, assigns the color specified to all bars.

Example: `bar(Y, 'r')`

Data Types

char

axes_handle - Axes handle

current axes (default) | axes handle

Axes handle specifying the target axes for the bar graph.

Example: `bar(ah, Y);`

Name-Value Pair Arguments

Specify optional comma-separated pairs of `Name, Value` arguments. `Name` is the argument name and `Value` is the corresponding value. `Name` must appear inside single quotes (' '). You can specify several name and value pair arguments in any order as `Name1, Value1, ..., NameN, ValueN`.

For more information see “Barseries Property Descriptions” on page 1-478.

Example: `bar(Y, 'EdgeColor', 'g')`

‘BarLayout’ - Arrangement of bars

grouped (default) | stacked

Arrangement of bars, specified as the comma-separated pair consisting of 'BarLayout' and one of these values:

- **grouped** — Display m groups of n vertical bars, where m is the number of rows and n is the number of columns in the input argument Y . The group contains one bar per column in Y .
- **stacked** — Display one bar for each row in the input argument Y . The bar height is the sum of the elements in the row. Each bar is multicolored, with colors corresponding to distinct elements and showing the relative contribution each row element makes to the total sum.

‘BaseValue’ - Base line location

0 (default) | scalar

Base line location, specified as the comma-separated pair consisting of 'BaseValue' and the value along the y -axis (vertical bars) or x -axis (horizontal bars) at which MATLAB draws the baseline.

‘BarWidth’ - Relative width of bars

0.8 (default) | scalar

Relative bar width, specified as the comma-separated pair consisting of 'BarWidth' and a value relative to width and spacing. `BarWidth` controls the separation of bars within a group. By default, the bars within a group have a slight separation. A value of 1 makes bars touch with no space. A value greater than 1 makes the bars overlap.

‘EdgeColor’ - Color of bar edges

[0,0,0] (default) | none | ColorSpec

Color of bar edges, specified as the comma-separated pair consisting of 'EdgeColor' and a three-element RGB vector, or one of the MATLAB predefined color specifier names.

'FaceColor' - Color of bars

flat (default) | none | ColorSpec

Color of bars, specified as the comma-separated pair consisting of 'FaceColor' and one of these values:

- flat — Use the figure colormap to determine the color of the bars.
- ColorSpec — A three-element RGB vector or one of the MATLAB predefined names, specifying a single color for all bars.
- none — Do not draw faces. Note that MATLAB draws EdgeColor independently of FaceColor.

'LineStyle' - Line style of bar edges

— (default) | - | -- | : | -. | none

Line style of bar edges, specified as the comma-separated pair consisting of 'LineStyle' and one of the predefined line style strings.

'LineWidth' - Width of bar edges

0.5 points (default) | scalar width specified in points

Width of bar edges, specified as the comma-separated pair consisting of 'LineWidth' and a scalar value representing the line width in points.

Output Arguments

h - Handle to barseries objects

array of one or more handles

Handle to barseries objects, returned as an array of one or more handles.

Examples

Single Data Series

Use the bar function to plot vector data.

```
y = [75.995,91.972,105.711,123.203,131.669,...  
     150.697,179.323,203.212,226.505,249.633,281.422];
```

```
figure;  
bar(y);
```

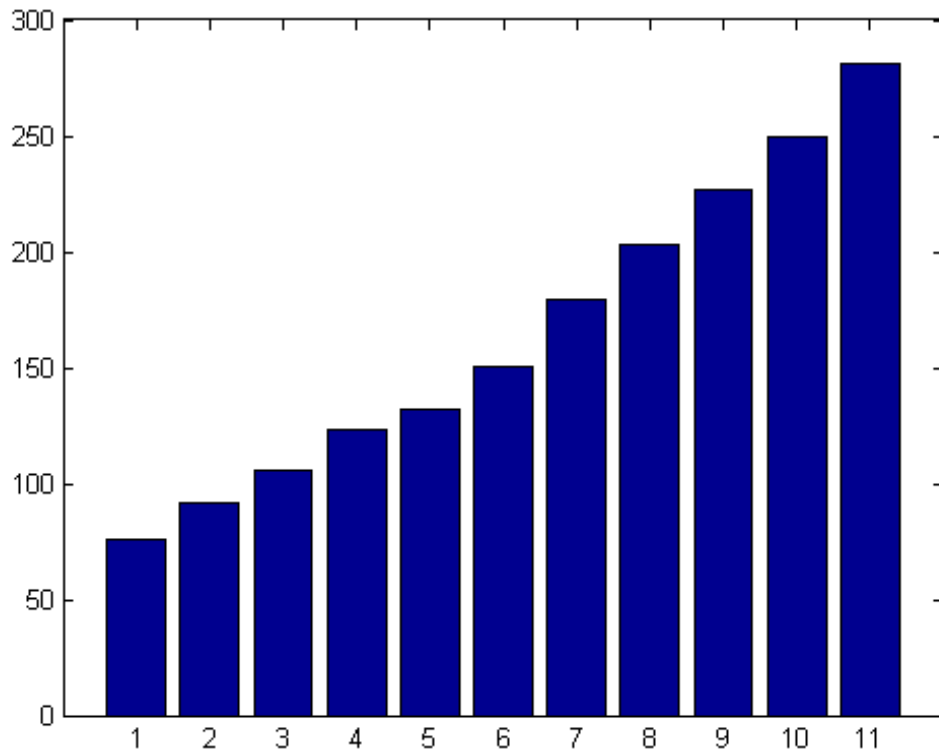

X-Axis Tick Labels

Specify the numeric values of the *x*-axis tick labels.

```
x = 1900:10:2000;  
y = [75.995,91.972,105.711,123.203,131.669,...  
     150.697,179.323,203.212,226.505,249.633,281.422];
```

bar

```
figure;  
bar(x,y);
```

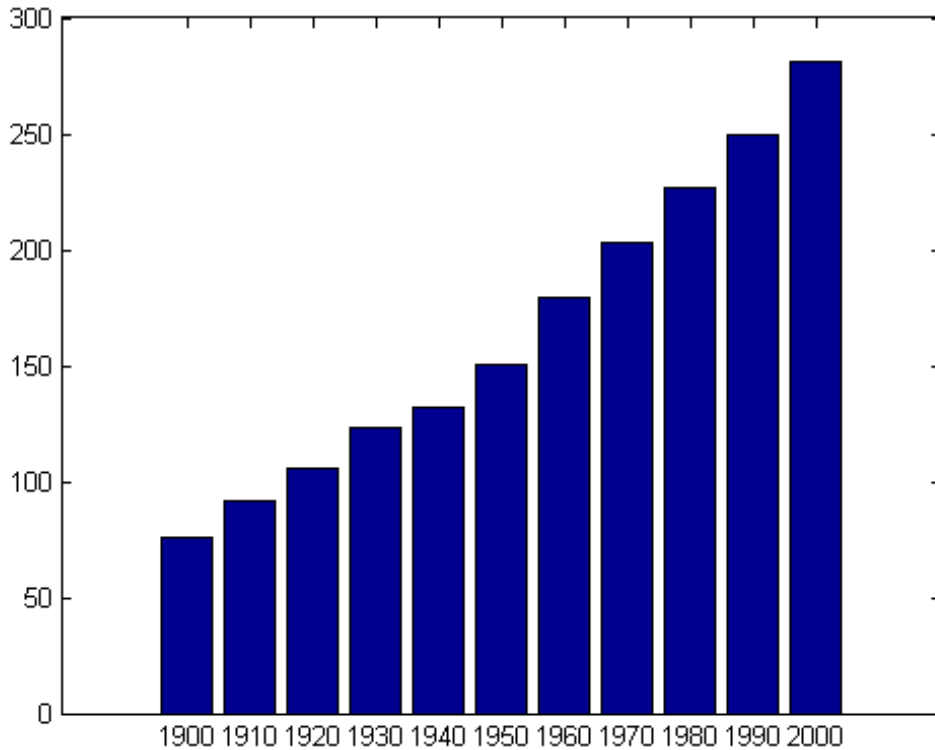

Plot the y -values at each x -value. Notice that the `length(x)` and `length(y)` have to be same.

Bar Width

Set width of each bar to 40 percent of the total space available for each bar.

```
y = [75.995,91.972,105.711,123.203,131.669,...  
     150.697,179.323,203.212,226.505,249.633,281.422];  
figure;  
bar(y,0.4);
```

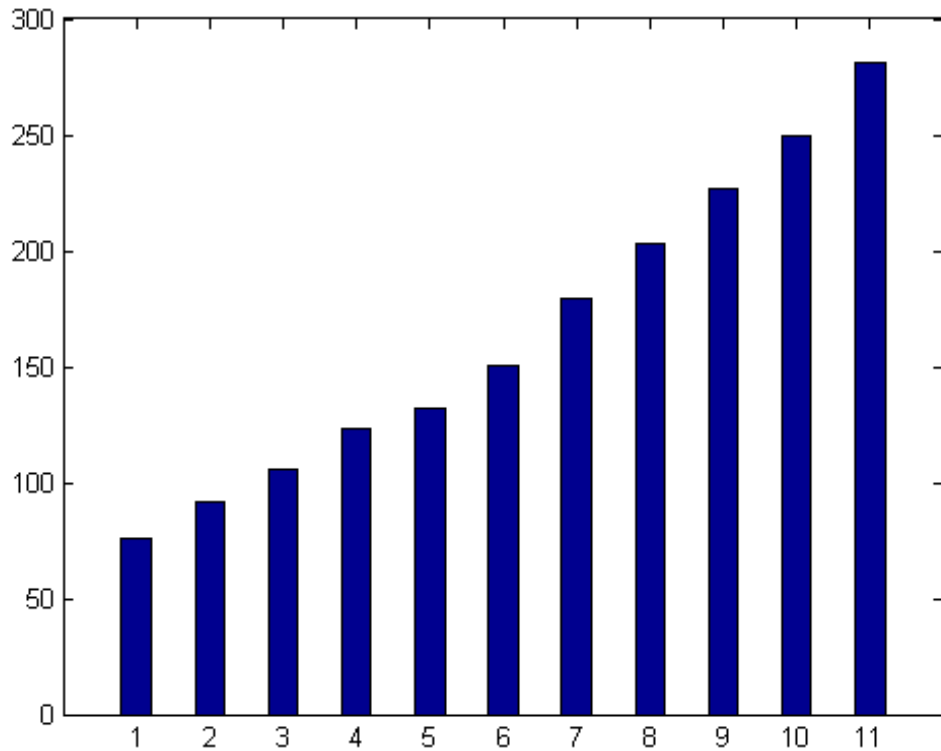

Bar Graph Styles

Create a figure with four subplots containing bar graphs. In each subplot, apply a different style to the bar graph.

bar

```
Y = round(rand(5,3)*10);

figure;
subplot(2,2,1);
bar(Y, 'grouped');
title('Group')

subplot(2,2,2);
bar(Y, 'stacked');
title('Stack')

subplot(2,2,3);
bar(Y, 'histc');
title('Histic')

subplot(2,2,4);
bar(Y, 'hist');
title('Hist')
```

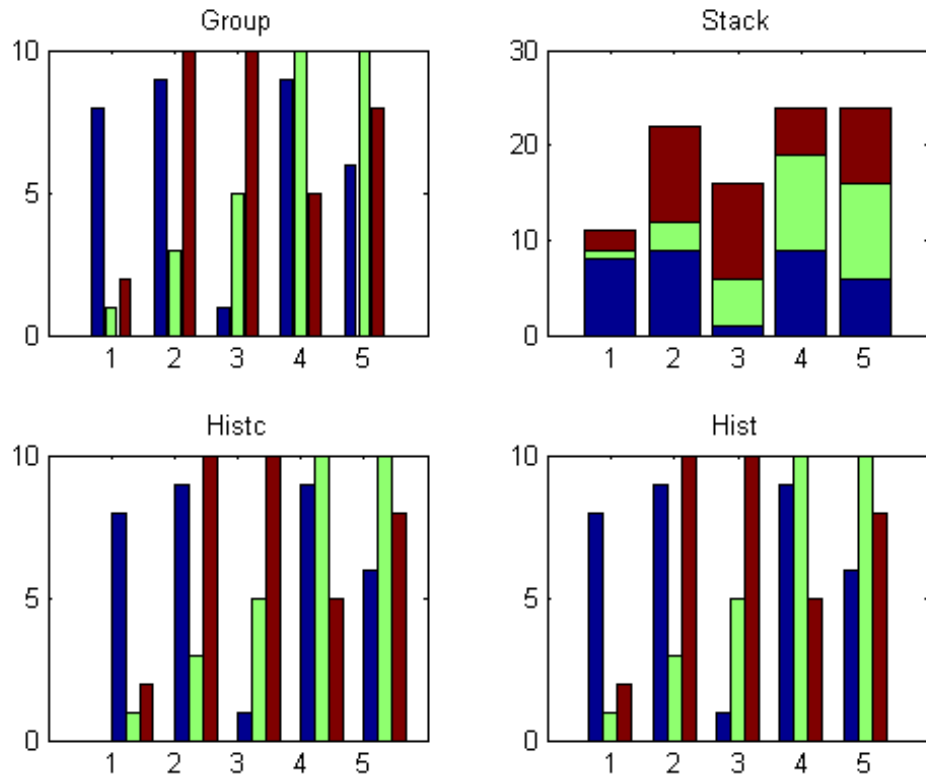

Specify Axes

Specify the axes for the bar graph by passing an axes handle to `bar`.

```
rng(0,'twister'); % initialize random number generator
Y = round(rand(5,3)*10);
```

```
figure;
ax = subplot(2,1,2);
bar(ax,Y,'stacked');
```

bar

```
title('Lower Subplot')
```

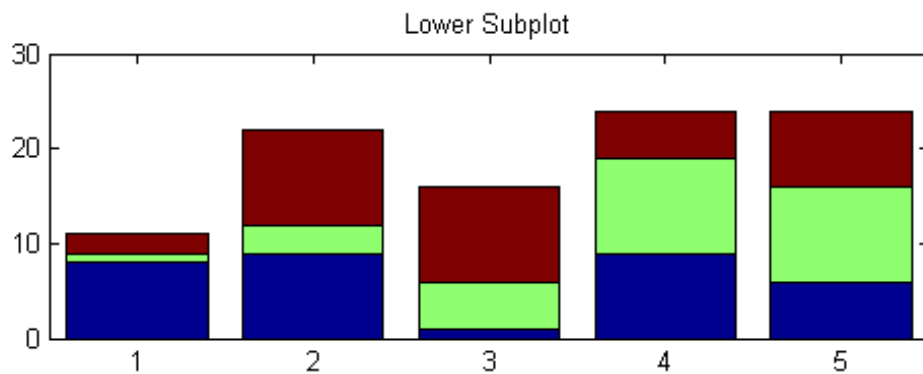

Bar Color

Specify a red color for the bar graph.

```
y = [75.995,91.972,105.711,123.203,131.669,...  
      150.697,179.323,203.212,226.505,249.633,281.422];  
figure;  
bar(y,'r');
```

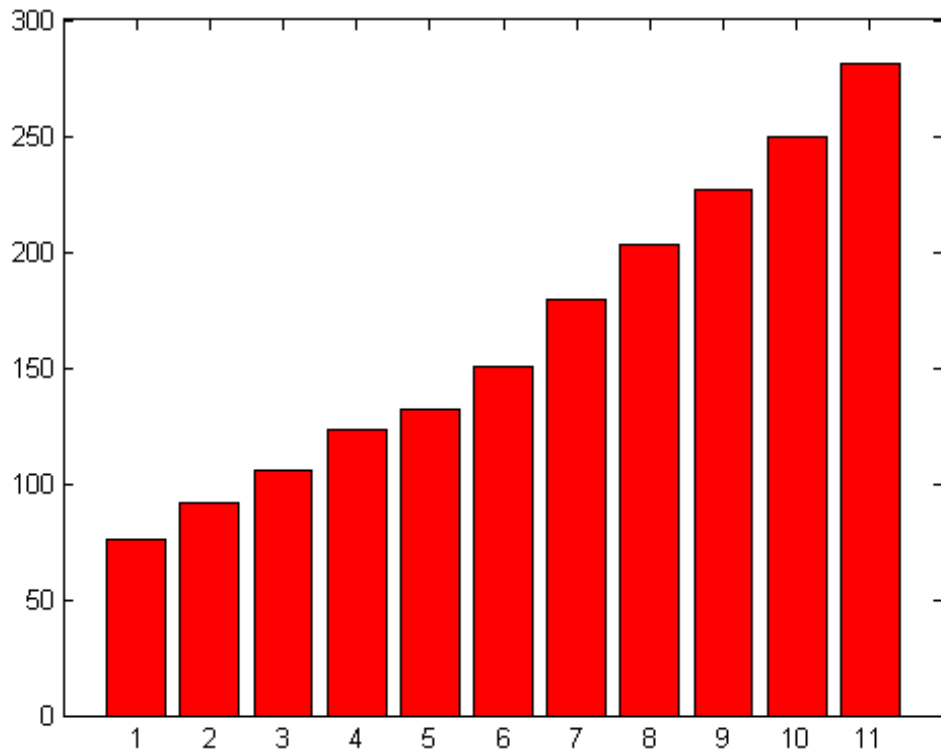

Bar Face and Edge Color

Specify green bars and use an RGB color specification for the bar edge color.

```
y = [75.995,91.972,105.711,123.203,131.669,...  
      150.697,179.323,203.212,226.505,249.633,281.422];  
figure;  
bar(y, 'g', 'EdgeColor', [1,0.5,0.5]);
```

bar

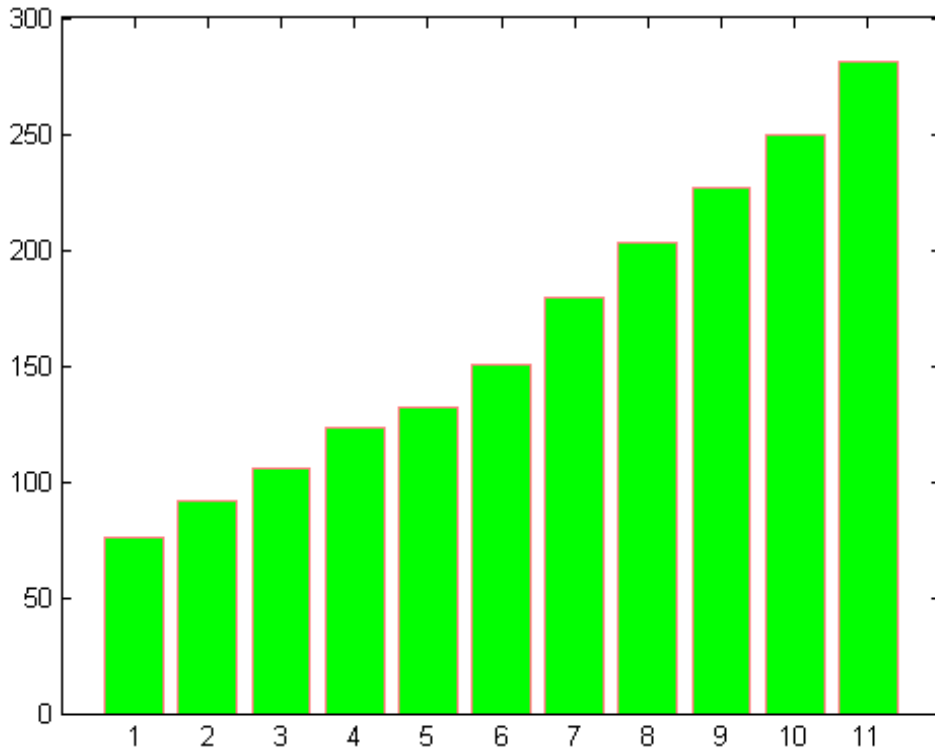

Bar Graph of 2-D Array

Plot a 6-by-3 array as six groups with three bars each.

```
c = load('count.dat');  
Y = c(1:6,:);  
figure;  
bar(Y);
```

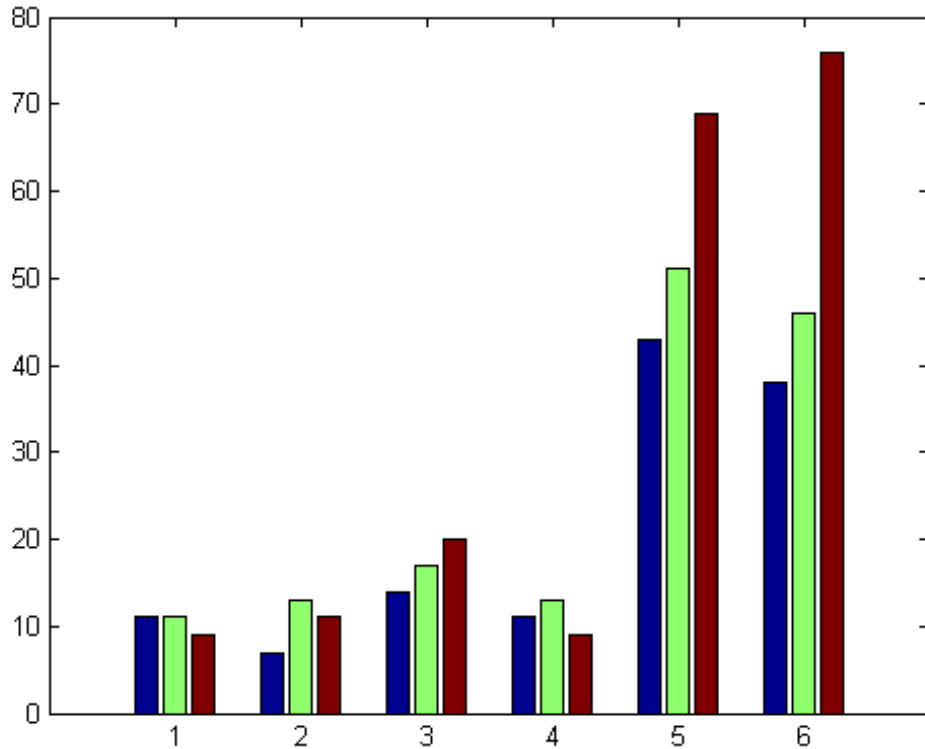

Emphasize Subset of Data

Set appearance of one column of data.

Set `LineWidth` and `EdgeColor` for the bars representing the second column in the data array `y`. Pass the handles returned by `bar` to the `set` function to set the barseries properties.

```
c = load('count.dat');  
Y = c(1:6,:);
```

bar

```
figure
hArray = bar(Y);
set(hArray(2),'LineWidth',2,'EdgeColor','red');
```

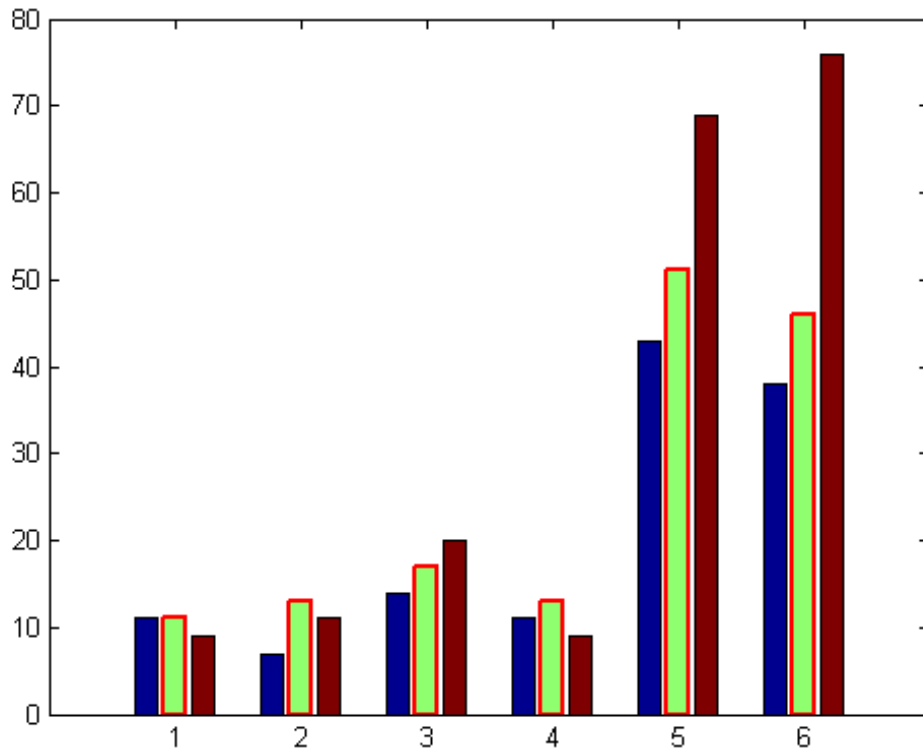

See Also

[barh](#) | [bar3](#) | [bar3h](#) | [ColorSpec](#) | [stairs](#) | [hist](#)

Related Examples

- “Modify Baseline of Bar Graph”
- “Overlay Bar Graphs”
- “Overlay Line Plot on Bar Graph Using Two y-Axes”

barh

Purpose

Plot bar graph horizontally

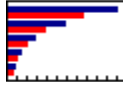

Syntax

```
barh(Y)
barh(X,Y)
barh(...,width)
barh(...,'style')
barh(...,'bar_color')
barh(...,'PropertyName',PropertyValue,...)
barh(axes_handle,...)
h = barh(...)
```

Description

A barh graph displays the values in a vector or matrix as horizontal bars.

`barh(Y)` draws one horizontal bar for each element in `Y`. If `Y` is a matrix, `barh` groups the bars produced by the elements in each row. The `x`-axis scale ranges from 1 up to `length(Y)` when `Y` is a vector, and 1 to `size(Y,1)`, which is the number of rows, when `Y` is a matrix. The default is to assign an appropriate progression of tick values according to the data. If you want the `x`-axis scale to end exactly at the last bar, set the axis limits as,

```
set(gca,'XLim',[1 length(Y)])
```

`barh(X,Y)` draws a bar for each element in `Y` at locations specified in `x`, where `X` is a vector defining the `x`-axis intervals for the vertical bars. The `x`-values can be nonmonotonic, but cannot contain duplicate values. If `Y` is a matrix, `barh` groups the elements of each row in `Y` at corresponding locations in `X`.

`barh(...,width)` sets the relative bar width and controls the separation of bars within a group. The default `width` is 0.8, so if you do not specify `X`, the bars within a group have a slight separation. If

width is 1, the bars within a group touch one another. The value of width must be a scalar.

`barh(..., 'style')` specifies the style of the bars. `'style'` is `'grouped'` or `'stacked'`. Default mode of display is `'grouped'`.

- `'grouped'` displays m groups of n vertical bars, where m is the number of rows and n is the number of columns in Y . The group contains one bar per column in Y .
- `'stacked'` displays one bar for each row in Y . The bar height is the sum of the elements in the row. Each bar is multicolored, with colors corresponding to distinct elements and showing the relative contribution each row element makes to the total sum.
- `'histc'` displays the graph in histogram format, in which bars touch one another.
- `'hist'` also displays the graph in histogram format, but centers each bar over the x -ticks, rather than making bars span x -ticks as the `histc` option does.

Note When you use either the `hist` or `histc` option, you cannot also use parameter/value syntax. These two options create graphic objects that are patches rather than barseries.

`barh(..., 'bar_color')` displays all bars using the color specified by the single-letter abbreviation `'r'`, `'g'`, `'b'`, `'c'`, `'m'`, `'y'`, `'k'`, or `'w'`.

`barh(..., 'PropertyName', PropertyValue, ...)` sets the named property or properties to the specified values. You cannot specify properties when `hist` or `histc` options are used. See the barseries property descriptions for information on what properties you can set.

`barh(axes_handle, ...)` plots into the axes with the handle `axes_handle` instead of into the current axes (`gca`).

barh

`h = barh(...)` returns a vector of handles to `barseries` graphics objects, one for each created. When `Y` is a matrix, `barh` creates one `barseries` graphics object per column in `Y`.

Barseries Objects

Creating a bar graph of an m -by- n matrix creates m groups of n `barseries` objects. Each `barseries` object contains the data for corresponding x values of each bar group (as indicated by the coloring of the bars).

Examples

Horizontal Bar Graph of Single Data Series

Create a horizontal bar graph of vector data.

```
y = [57,91,105,123,131,150,...  
     170,203,226.5,249,281.4];  
figure;  
barh(y);
```

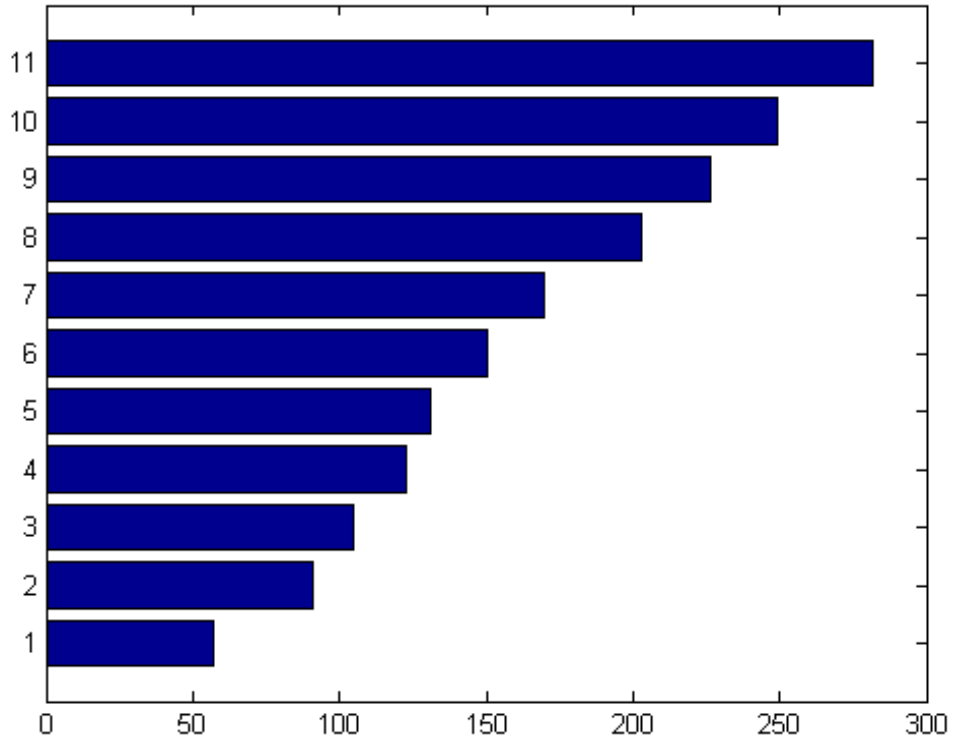

`barh` draws one horizontal bar for each element in `y`.

Specify Width for Horizontal Bar Graph

Specify the bar width to 0.4.

```
y = [57,91,105,123,131,150,...  
      170,203,226.5,249,281.4];
```

```
figure;
```

barh

```
width = 0.4;  
barh(y,width);
```

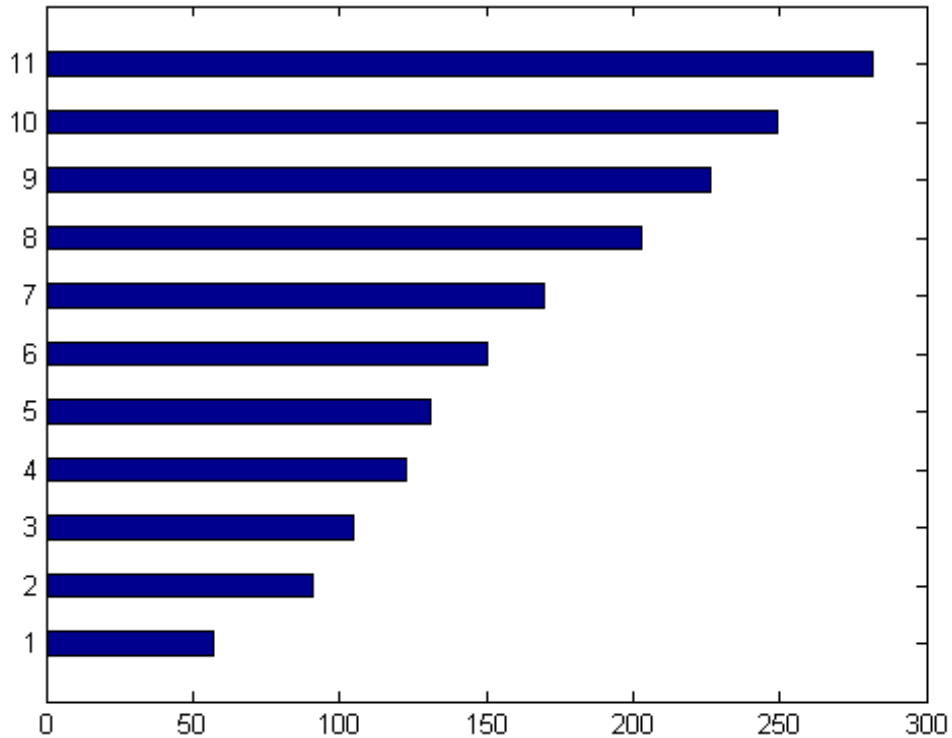

Specify Style for Horizontal Bar Graph

Create a figure with four subplots. In each subplot, create a horizontal bar graph using a different style option for each graph.

```
x = [2,4];  
y = [1,2,3,4;...]
```

```
    5,6,7,8];

figure;
subplot(2,2,1);
barh(x,y,'grouped'); % groups by row
title('Grouped Style')

subplot(2,2,2);
barh(x,y,'stacked'); % stacks values in each row together
title('Stacked Style')

subplot(2,2,3);
barh(x,y,'hist'); % centers bars over x values
title('hist Style')

subplot(2,2,4);
barh(x,y,'histc'); % spans bars over x values
title('histc Style')
```

barh

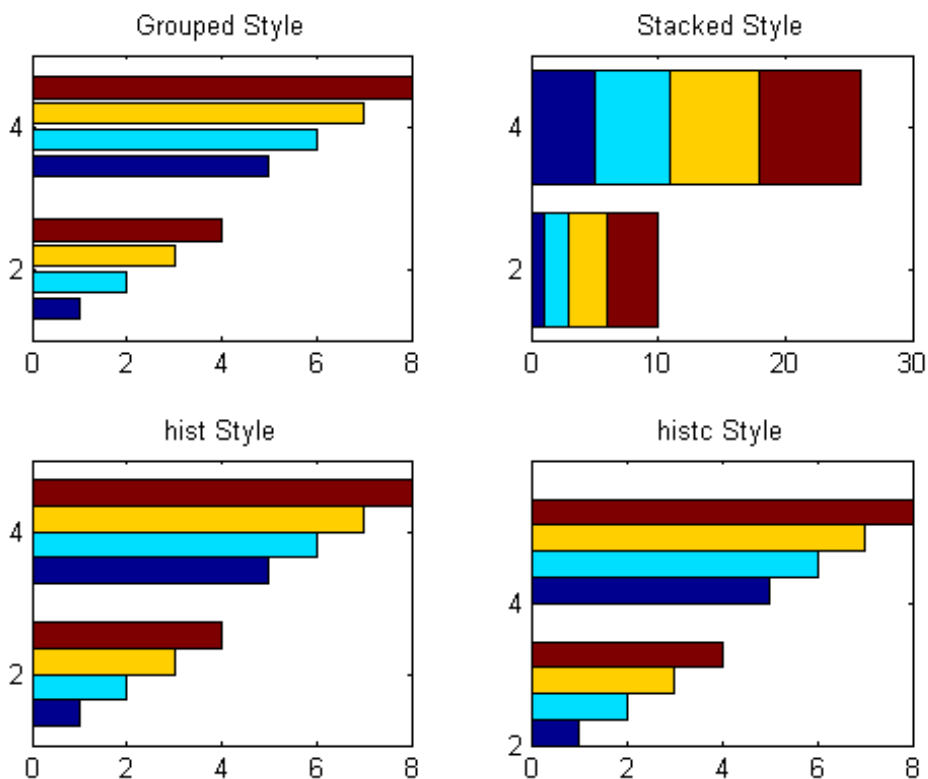

Specify Color for Horizontal Bar Graph

Create a horizontal bar graph and change the color of the bars to red.

```
y = [57,91,105,123,131,150,...  
      170,203,226.5,249,281.4];  
figure  
barh(y, 'r')
```

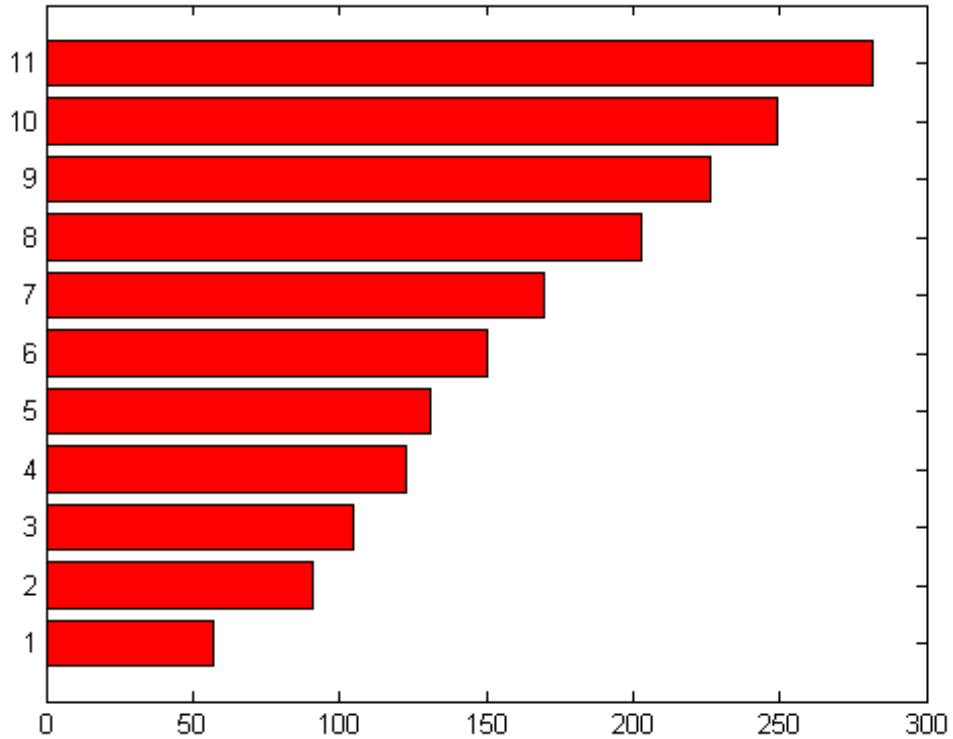
Specify Bar Properties Using Name-Value Pairs

Create a horizontal bar graph and set the line width to 2. Use RGB triplets to set the face color and edge color for the bars.

```
y = [57,91,105,123,131,150,...  
      170,203,226.5,249,281.4];  
  
figure  
barh(y, 'FaceColor', [0,0.5,0.5], ...
```

barh

```
'EdgeColor',[0,0,0.9],...  
'LineWidth',2)
```

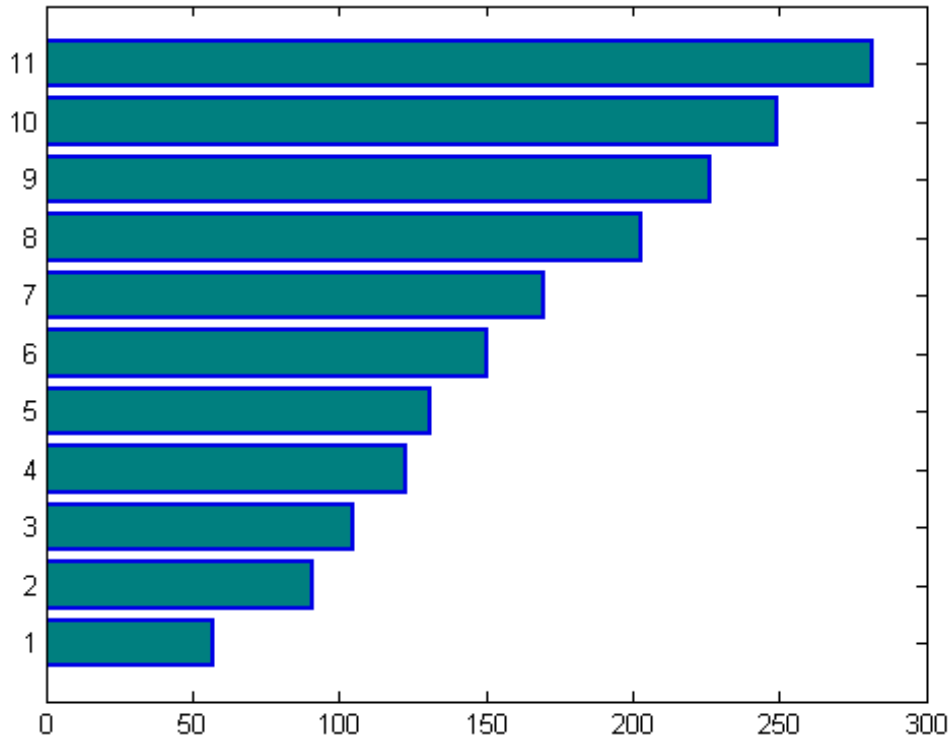

Specify Horizontal Bar Locations

Define x and y as vectors of data.

```
x = 1900:10:2000;  
y = [57,91,105,123,131,150,...  
     170,203,226.5,249,281.4];
```

Create a horizontal bar graph of the data in `y`. Use `x` to specify the bar locations along the `y`-axis.

```
figure  
barh(x,y)
```

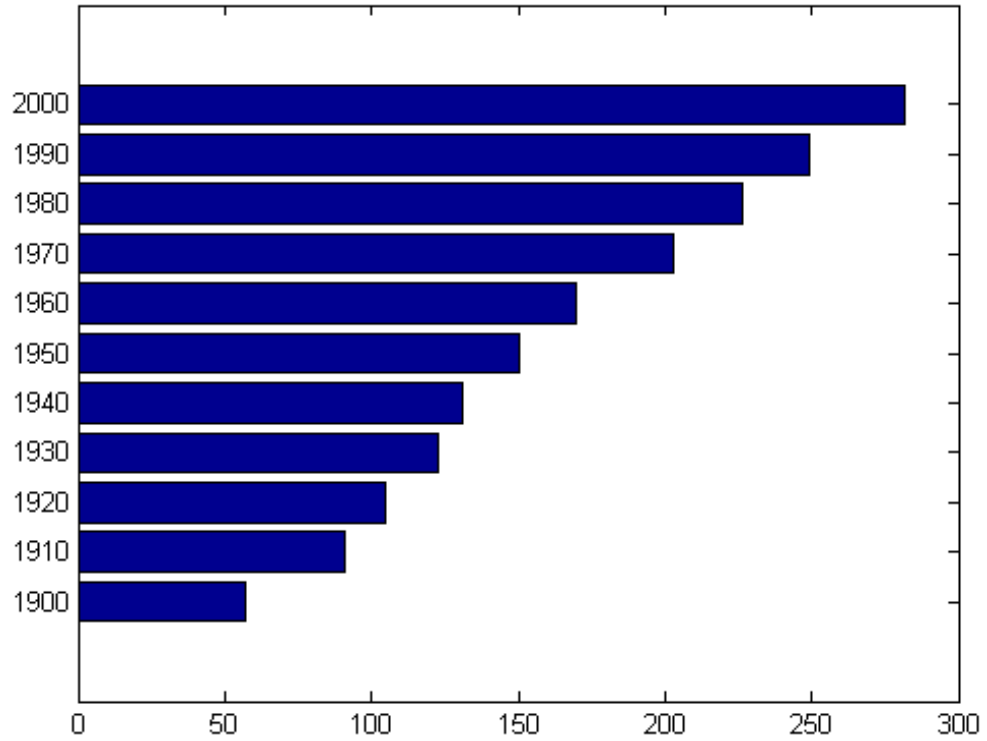

Horizontal Bar Graph of Matrix Data

Load the data set `count.dat`, which returns a three-column matrix, `count`. Store `y` as the first six rows of `count`.

```
load count.dat;  
y = count(1:6,:);
```

Create a horizontal bar graph of matrix `y`.

```
figure;  
barh(y);
```

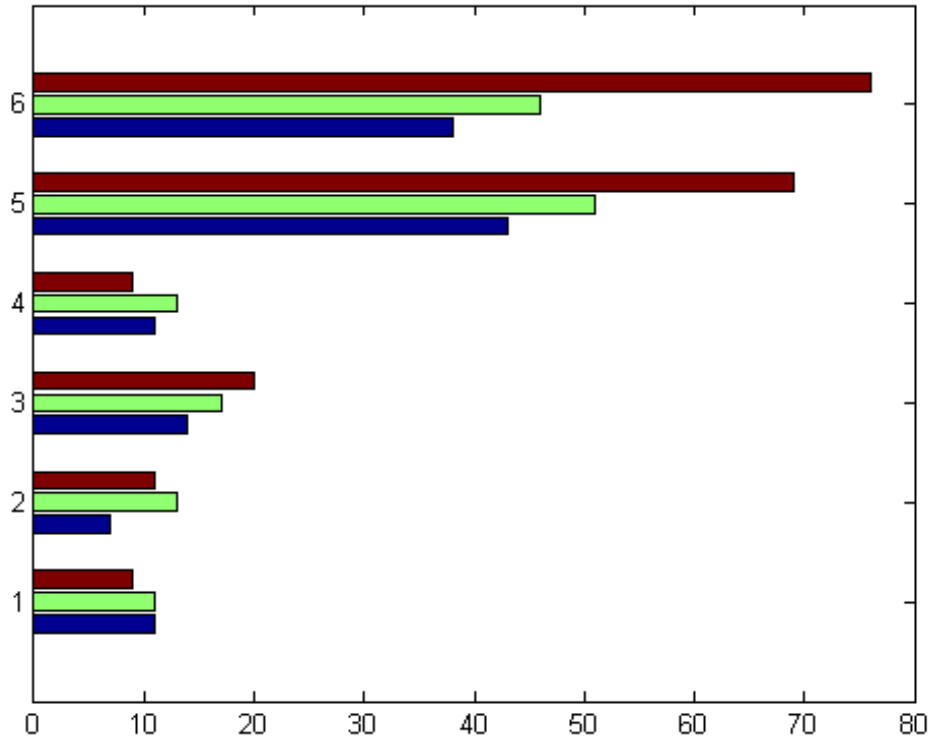

By default, `barh` groups the bars by row.

Specify Bar Properties for Multiple Barseries Objects

Load the data set, `count.dat`, which returns a three-column array, `count`. Store `y` as the first six rows of `count`.

```
load count.dat;  
y = count(1:6,:);
```

barh

Create a horizontal bar graph of `y` and return the handles to the three barseries objects. Set the line width and line style for all three sets of bars.

```
figure  
h = barh(y,'LineWidth',2,...  
         'LineStyle',':');
```

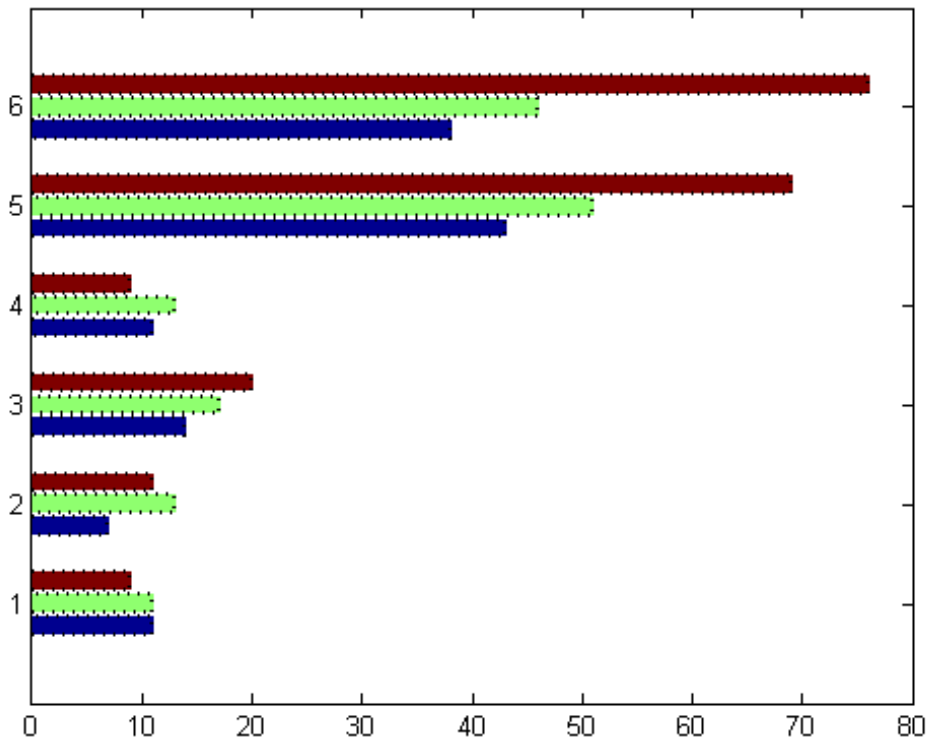

Use the barseries object handles to set Name-Value pairs for a specific barseries object. Set the face color for the first barseries object to cyan. Set the face color for the last barseries object to an RGB color value.

```
set(h(1), 'FaceColor', 'c')  
set(h(3), 'FaceColor', [0,0.5,0.5])
```

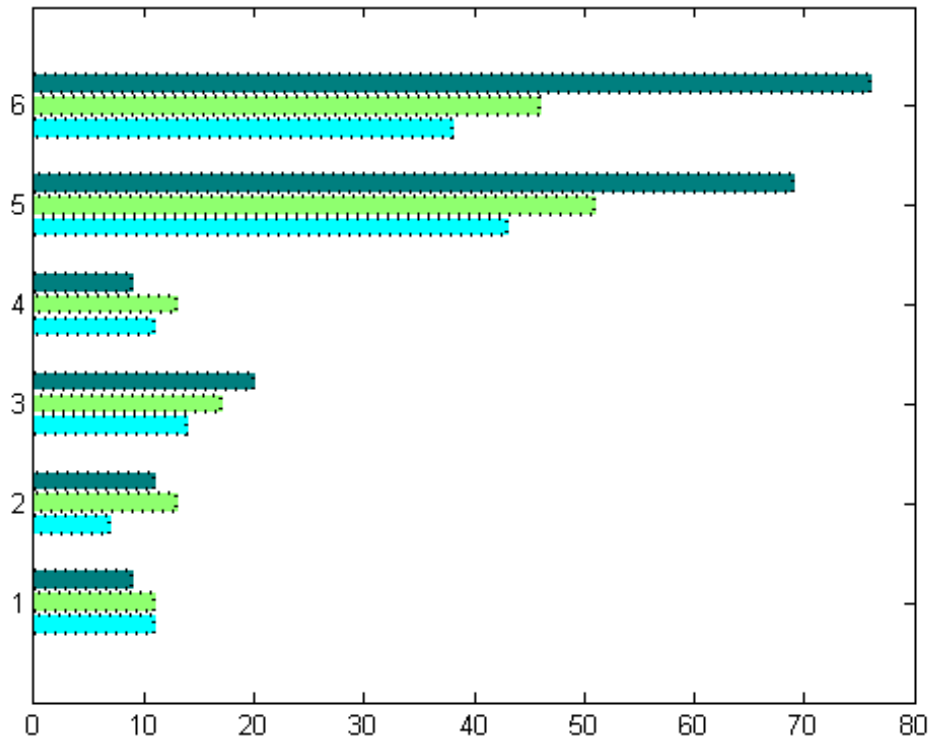

Change Baseline Value for Horizontal Bar Graph

Load the data set `count.dat`, which returns a three-column matrix, `count`. Store `y` as the first six rows of `count`.

```
load count.dat;  
y = count(1:6,:);
```

Create a horizontal bar graph of `y` and set the basevalue to 25.

```
figure  
barh(y, 'BaseValue', 25);
```

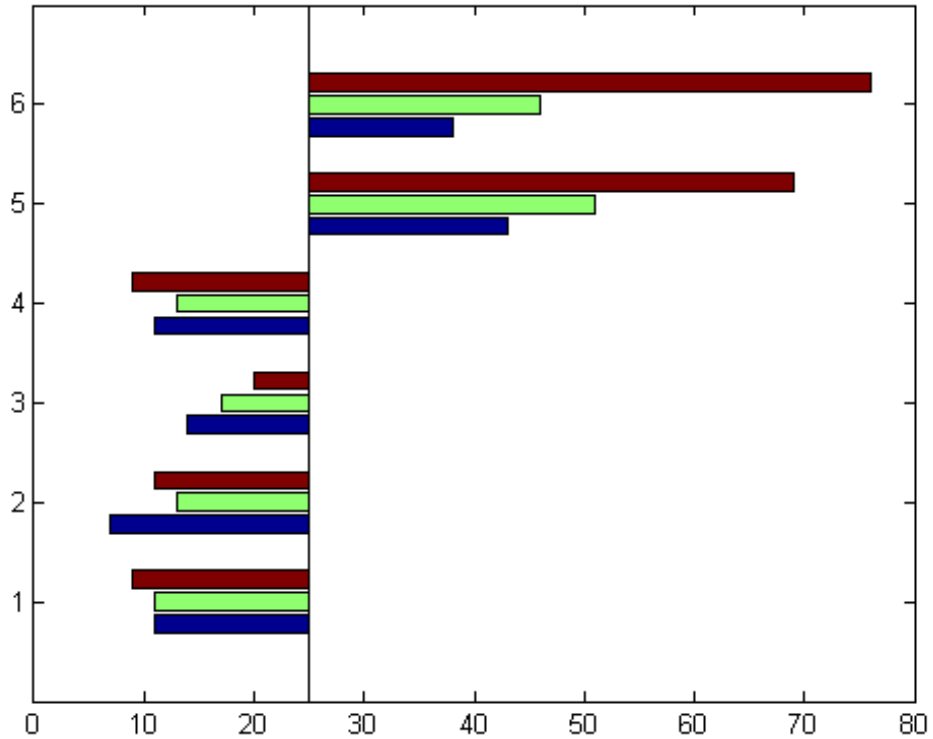
**See Also**

`bar` | `bar3` | `bar3h` | `ColorSpec` | `stairs` | `hist` | `Barseries` Properties

How To

- “Modify Baseline of Bar Graph”
- “Overlay Bar Graphs”
- “Overlay Line Plot on Bar Graph Using Two y-Axes”

bar3

Purpose

Plot 3-D bar graph

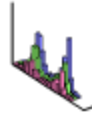

Syntax

```
bar3(Y)
bar3(x,Y)
bar3(...,width)
bar3(...,'style')
bar3(...,LineStyle)
bar3(axes_handle,...)
h = bar3(...)
```

Description

`bar3` draws a three-dimensional bar graph.

`bar3(Y)` draws a three-dimensional bar chart, where each element in `Y` corresponds to one bar. When `Y` is a vector, the `x`-axis scale ranges from 1 to `length(Y)`. When `Y` is a matrix, the `x`-axis scale ranges from 1 to `size(Y,1)` and the elements in each row are grouped together.

`bar3(x,Y)` draws a bar chart of the elements in `Y` at the locations specified in `x`, where `x` is a vector defining the `y`-axis intervals for vertical bars. The `x`-values can be nonmonotonic, but cannot contain duplicate values. If `Y` is a matrix, `bar3` clusters elements from the same row in `Y` at locations corresponding to an element in `x`. Values of elements in each row are grouped together.

`bar3(...,width)` sets the width of the bars and controls the separation of bars within a group. The default `width` is 0.8, so if you do not specify `x`, bars within a group have a slight separation. If `width` is 1, the bars within a group touch one another.

`bar3(...,'style')` specifies the style of the bars. `'style'` is `'detached'`, `'grouped'`, or `'stacked'`. Default mode of display is `'detached'`.

- 'detached' displays the elements of each row in Y as separate blocks behind one another in the x direction.
- 'grouped' displays n groups of m vertical bars, where n is the number of rows and m is the number of columns in Y . The group contains one bar per column in Y .
- 'stacked' displays one bar for each row in Y . The bar height is the sum of the elements in the row. Each bar is multicolored, with colors corresponding to distinct elements and showing the relative contribution each row element makes to the total sum.

`bar3(...,LineStyle)` displays all bars using the color specified by `LineStyle`.

`bar3(axes_handle,...)` plots into the axes with the handle `axes_handle` instead of into the current axes (`gca`).

`h = bar3(...)` returns a vector of handles to surface objects, one for each created. When Y is a matrix, `bar3` creates one surface object per column in Y .

Examples

Create 3-D Bar Graph

Load the data set `count.dat`, which returns a three-column matrix, `count`. Store Y as the first 10 rows of `count`.

```
load count.dat
Y = count(1:10,:);
```

Create a 3-D bar graph of Y . By default, the style is `detached`.

```
figure
bar3(Y)
title('Detached Style')
```

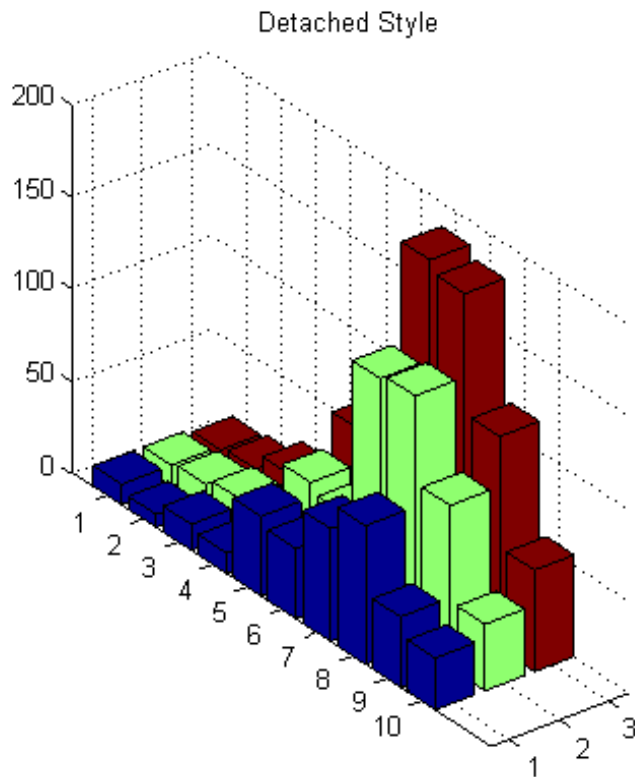

Specify Bar Width for 3-D Bar Graph

Load the data set `count.dat`, which returns a three-column matrix, `count`. Store `Y` as the first 10 rows of `count`.

```
load count.dat  
Y = count(1:10,:);
```

Create a 3-D bar graph of `Y` and set the bar width to 0.5.

```
width = 0.5;  
  
figure  
bar3(Y,width)  
title('Bar Width of 0.5')
```

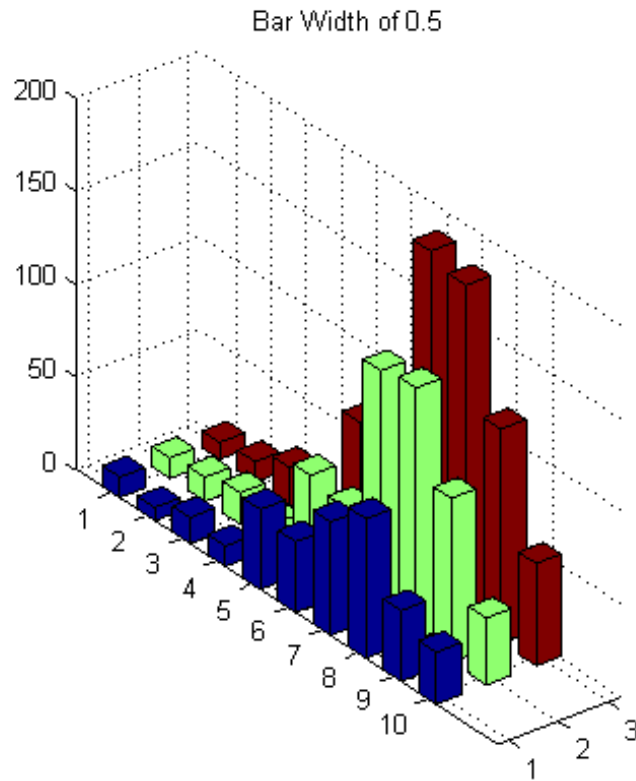

3-D Bar Graph with Grouped Style

Load the data set `count.dat`, which returns a three-column matrix, `count`. Store `Y` as the first 10 rows of `count`.

bar3

```
load count.dat  
Y = count(1:10,:);
```

Create a 3-D bar graph of Y. Group the elements in each row of Y by specifying the style option as grouped.

```
figure  
bar3(Y, 'grouped')  
title('Grouped Style')
```

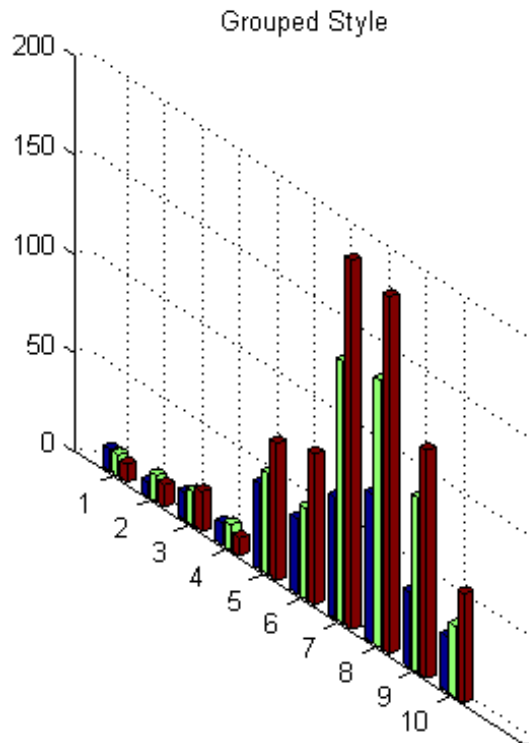

3-D Bar Graph with Stacked Style

Load the data set `count.dat`, which returns a three-column matrix, `count`. Store `Y` as the first 10 rows of `count`.

```
load count.dat
Y = count(1:10,:);
```

Create a 3-D bar graph of `Y`. Stack the elements in each row of `Y` by specifying the style option as `stacked`.

```
figure
bar3(Y,'stacked')
title('Stacked Style')
```

bar3

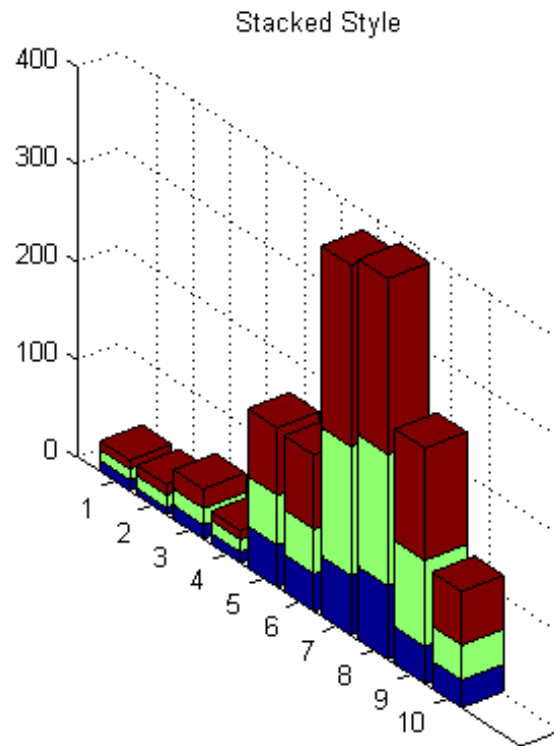

See Also

`bar` | `barh` | `bar3h` | `LineStyle`

How To

- “Color 3-D Bars by Height”

Purpose Plot horizontal 3-D bar graph



Syntax

```
bar3h(Y)
bar3h(x,Y)
bar3h(...,width)
bar3h(...,'style')
bar3h(...,LineStyle)
bar3h(axes_handle,...)
h = bar3h(...)
```

Description bar3h draws three-dimensional horizontal bar charts.

bar3h(Y) draws a three-dimensional bar chart, where each element in Y corresponds to one bar. When Y is a vector, the y-axis scale ranges from 1 to length(Y). When Y is a matrix, the y-axis scale ranges from 1 to size(Y,1) and the elements in each row are grouped together.

bar3h(x,Y) draws a bar chart of the elements in Y at the locations specified in x, where x is a vector defining the y-axis intervals for horizontal bars. The x-values can be nonmonotonic, but cannot contain duplicate values. If Y is a matrix, bar3 clusters elements from the same row in Y at locations corresponding to an element in x. Values of elements in each row are grouped together.

bar3h(...,width) sets the width of the bars and controls the separation of bars within a group. The default width is 0.8, so if you do not specify x, bars within a group have a slight separation. If width is 1, the bars within a group touch one another.

bar3h(...,'style') specifies the style of the bars. 'style' is 'detached', 'grouped', or 'stacked'. Default mode of display is 'detached'.

- 'detached' displays the elements of each row in Y as separate blocks behind one another in the y direction.

bar3h

- 'grouped' displays n groups of m vertical bars, where n is the number of rows and m is the number of columns in Y . The group contains one bar per column in Y .
- 'stacked' displays one bar for each row in Y . The bar length is the sum of the elements in the row. Each bar is multicolored, with colors corresponding to distinct elements and showing the relative contribution each row element makes to the total sum.

`bar3h(...,LineStyle)` displays all bars using the color specified by `LineStyle`.

`bar3h(axes_handle,...)` plots into the axes with the handle `axes_handle` instead of into the current axes (`gca`).

`h = bar3h(...)` returns a vector of handles to surface objects, one for each created. When Y is a matrix, `bar3h` creates one surface object per column in Y .

Examples

Create 3-D Horizontal Bar Graph

Load the data set `count.dat`, which returns a three-column matrix, `count`. Store Y as the first ten rows of `count`.

```
load count.dat;  
Y = count(1:10,:);
```

Create a 3-D horizontal bar graph of Y . By default, the style is `detached`.

```
figure  
bar3h(Y)
```

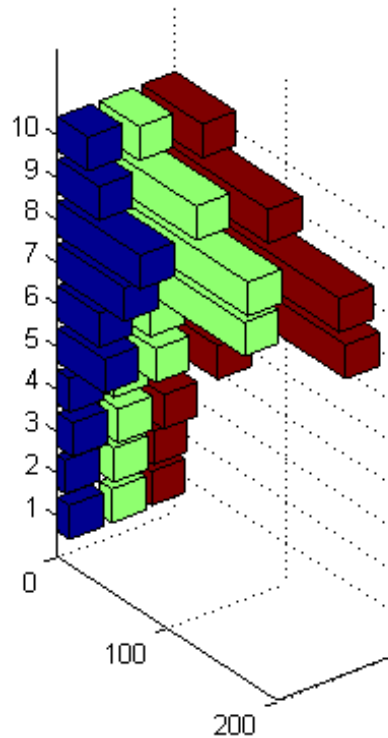

Specify Bar Width for 3-D Horizontal Bar Graph

Load the data set `count.dat`, which returns a three-column matrix, `count`. Store `Y` as the first ten rows of `count`.

```
load count.dat;  
Y = count(1:10,:);
```

Create a 3-D horizontal bar graph of `Y` and set the bar width to 0.5.

bar3h

```
width = 0.5;  
  
figure  
bar3h(Y,width)  
title('Width of 0.5')
```

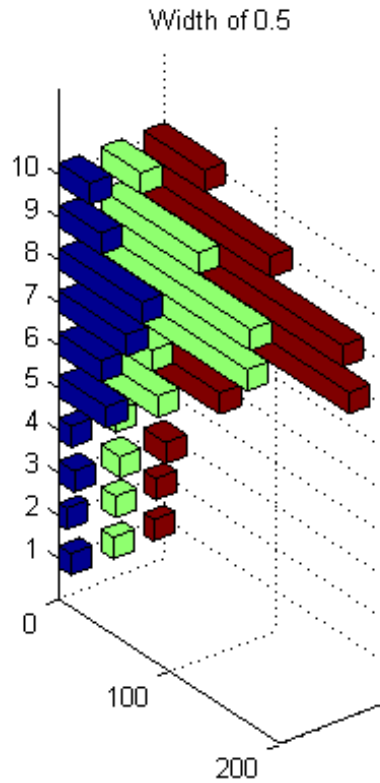

3-D Horizontal Bar Graph with Grouped Style

Load the data set `count.dat`, which returns a three-column matrix, `count`. Store `Y` as the first ten rows of `count`.

```
load count.dat;  
Y = count(1:10,:);
```

Create a 3-D horizontal bar graph of Y and specify the style option as grouped.

```
figure  
bar3h(Y,'grouped')  
title('Grouped Style Option')
```

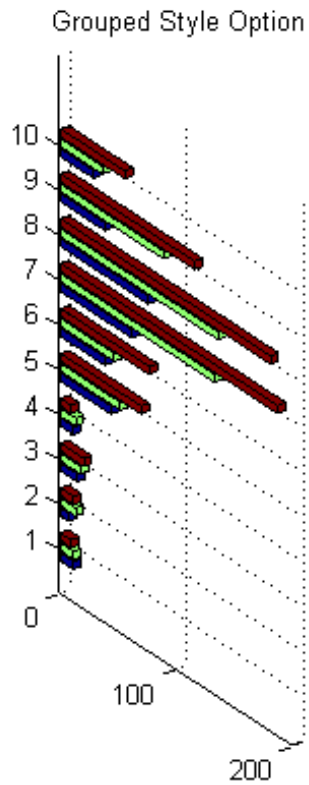

3-D Horizontal Bar Graph with Stacked Option

Load the data set `count.dat`, which returns a three-column matrix, `count`. Store `Y` as the first ten rows of `count`.

```
load count.dat;  
Y = count(1:10,:);
```

Create a 3-D horizontal bar graph of `Y` and specify the style option as `stacked`.

```
figure  
bar3h(Y, 'stacked')  
title('Stacked Style Option')
```

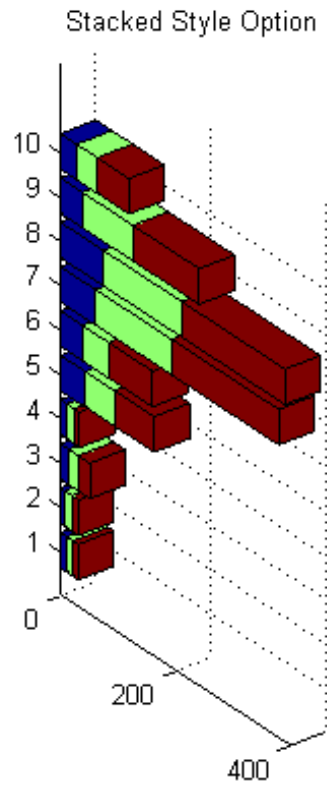
**See Also**

bar | barh | bar3 | LineSpec | patch

Barseries Properties

Purpose Define barseries properties

Modifying Properties You can set and query graphics object properties using the set and get commands or the Property Editor (propertyeditor).

Note that you cannot define default properties for barseries objects.

See “Plot Objects” for more information on barseries objects.

Barseries Property Descriptions

This section provides a description of properties. Curly braces { } enclose default values.

Annotation

hg.Annotation object (read-only)

Control the display of barseries objects in legends. Specifies whether this barseries object is represented in a figure legend.

Querying the Annotation property returns the handle of an hg.Annotation object. The hg.Annotation object has a property called LegendInformation, which contains an hg.LegendEntry object.

Once you have obtained the hg.LegendEntry object, you can set its IconDisplayStyle property to control whether the barseries object is displayed in a figure legend.

IconDisplayStyle Value	Purpose
on	Include the barseries object in a legend as one entry, but not its children objects
off	Do not include the barseries or its children in a legend (default)
children	Include only the children of the barseries as separate entries in the legend

Setting the IconDisplayStyle Property

These commands set the `IconDisplayStyle` of a graphics object with handle `hobj` to `children`, which causes each child object to have an entry in the legend:

```
hAnnotation = get(hobj, 'Annotation');  
hLegendEntry = get(hAnnotation, 'LegendInformation');  
set(hLegendEntry, 'IconDisplayStyle', 'children')
```

Using the IconDisplayStyle Property

See “Control Legend Content” for more information and examples.

`BarLayout`
`{grouped} | stacked`

Specify grouped or stacked bars.

- `grouped` — Display m groups of n vertical bars, where m is the number of rows and n is the number of columns in the input argument Y . The group contains one bar per column in Y .
- `stacked` — Display one bar for each row in the input argument Y . The bar height is the sum of the elements in the row. Each bar is multicolored, with colors corresponding to distinct elements and showing the relative contribution each row element makes to the total sum.

`BarWidth`
scalar in range [0 1]

Width of individual bars. `BarWidth` specifies the relative bar width and controls the separation of bars within a group. The default is 0.8, so if you do not specify `x`, the bars within a group have a slight separation. If `BarWidth` is 1, the bars within a group touch one another.

`BaseLine`
handle

Barseries Properties

Handle of the baseline line object. Handle of the line object used as the baseline. You can set the properties of this line using its handle.

Create a bar graph, obtain the handle of the baseline from the barseries object, and then set line properties that make the baseline a dashed, red line:

```
bar_handle = bar(randn(10,1));  
baseline_handle = get(bar_handle,'BaseLine');  
set(baseline_handle,'LineStyle','--','Color','red')
```

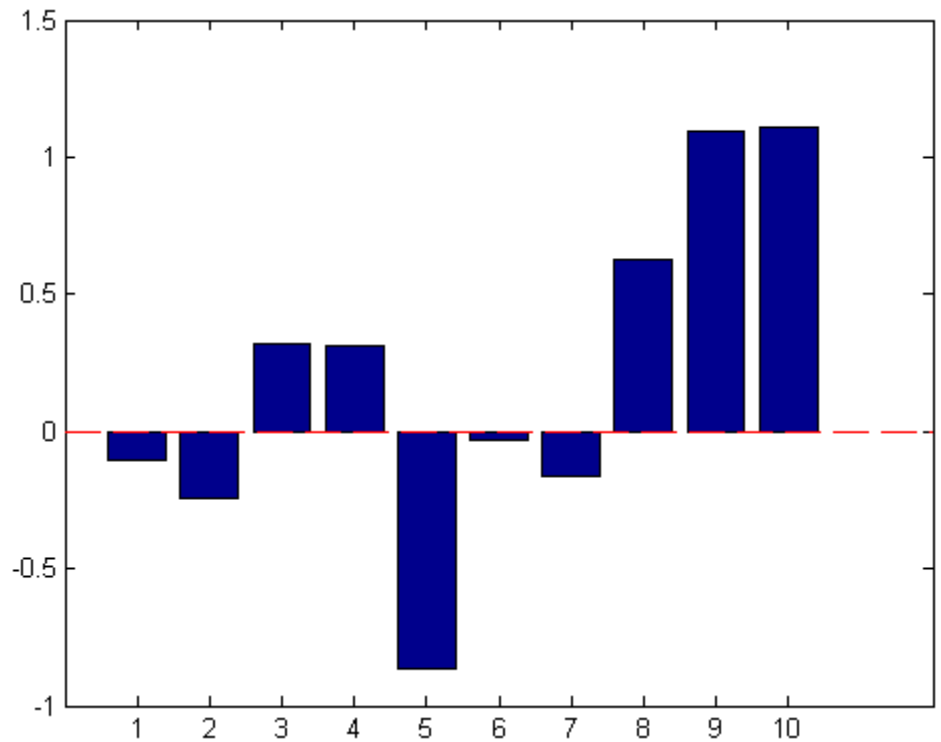

BaseValue
double: y-axis value

Baseline location. You can specify the value along the y -axis (vertical bars) or x -axis (horizontal bars) at which the MATLAB software draws the baseline. The default is 0.

BeingDeleted
on | {off} (read-only)

This object is being deleted. Mechanism to determine if objects are in the process of being deleted. MATLAB sets the **BeingDeleted** property to **on** when the object's delete function callback is called (see the **DeleteFcn** property). It remains set to **on** while the delete function executes, after which the object no longer exists.

For example, an object's delete function calls other functions that act on a number of different objects. If a function does not need to perform an action on an about-be-deleted object, it can check the object's **BeingDeleted** property before acting.

BusyAction
cancel | {queue}

Callback queuing

Determines how MATLAB handles the execution of interrupting callbacks.

A *running* callback is the currently executing callback. The *interrupting* callback is the callback that tries to interrupt the *running* callback. The **BusyAction** property of the *interrupting* callback determines how MATLAB handles its execution. When the **BusyAction** property is set to:

- 'queue' — Puts the *interrupting* callback in a queue to be processed after the *running* callback finishes execution.
- 'cancel' — Discards the *interrupting* callback as MATLAB finishes execution.

Barseries Properties

For information about how the `Interruptible` property of the callback controls whether other callbacks can interrupt the *running* callback, see the `Interruptible` property description.

`ButtonDownFcn`
string | function handle

Button press callback function. Executes whenever you press a mouse button while the pointer is over this object, but not over another graphics object. See the `HitTestArea` property for information about selecting objects of this type.

See the figure's `SelectionType` property to determine if modifier keys were also pressed.

This property can be:

- A string that is a valid MATLAB expression
- The name of a MATLAB file
- A function handle

Set this property to a function handle that references the callback. The expressions execute in the MATLAB workspace.

For information on the syntax of callback functions, see `Function Handle Callbacks`.

`Children`
array of graphics object handles

Children of the barseries object. The handle of a patch object that is the child of this object (whether visible or not).

If a child object's `HandleVisibility` property is `callback` or `off`, its handle does not show up in this object's `Children` property. If you want the handle in the `Children` property, set the root `ShowHiddenHandles` property to `on`. For example:

```
set(0, 'ShowHiddenHandles', 'on')
```

Clipping

```
{on} | off
```

Clipping mode. MATLAB clips graphs to the axes plot box by default. If you set `Clipping` to `off`, portions of graphs appear outside the axes plot box. This occurs if you create a plot object, set `hold` to `on`, freeze axis scaling (`axis manual`), and then create a larger plot object.

CreateFcn

```
function handle | cell array containing function handle and  
additional arguments | string (not recommended)
```

Callback function executed during object creation. Defines a callback that executes when MATLAB creates an object. The default is an empty array.

You must specify the callback during the creation of the object. For example:

```
graphicfcn(y, 'CreateFcn', @CallbackFcn)
```

where `@CallbackFcn` is a function handle that references the callback function and `graphicfcn` is the plotting function which creates this object.

MATLAB executes this routine after setting all other object properties. Setting this property on an existing object has no effect.

The handle of the object whose `CreateFcn` is being executed is accessible only through the root `CallbackObject` property, which you can query using `gcbo`.

For information on the syntax of callback functions, see [Function Handle Callbacks](#).

Barseries Properties

DeleteFcn

function handle | cell array containing function handle and additional arguments | string (not recommended)

Callback executed during object deletion. Executes when this object is deleted (for example, this might happen when you issue a `delete` command on the object, its parent axes, or the figure containing it). MATLAB executes the callback before destroying the object's properties so the callback routine can query these values. The default is an empty array.

The handle of the object whose `DeleteFcn` is being executed is accessible only through the root `CallbackObject` property, which can be queried using `gcbo`.

For information on the syntax of callback functions, see [Function Handle Callbacks](#).

See the `BeingDeleted` property for related information.

DisplayName

string

String used by legend. The `legend` function uses the `DisplayName` property to label the barseries object in the legend. The default is an empty string.

- If you specify string arguments with the `legend` function, MATLAB set `DisplayName` to the corresponding string and uses that string for the legend.
- If `DisplayName` is empty, `legend` creates a string of the form, `['data' n]`, where `n` is the number assigned to the object based on its location in the list of legend entries. However, `legend` does not set `DisplayName` to this string.
- If you edit the string directly in an existing legend, MATLAB set `DisplayName` to the edited string.

- If you specify a string for the `DisplayName` property and create the legend using the figure toolbar, then MATLAB uses the string defined by `DisplayName`.
- To add a legend programmatically that uses the `DisplayName` string, call `legend` with the `toggle` or `show` option.

See “Control Legend Content” for more information and examples.

EdgeColor

`{[0 0 0]} | none | ColorSpec`

Color of line separating filled areas. You can set the color of the edges of filled areas to a three-element RGB vector or one of the MATLAB predefined names, including the string `none`. The default value is `[0 0 0]` (black). See the `ColorSpec` reference page for more information on specifying color.

EraseMode

`{normal} | none | xor | background`

Erase mode. Controls the technique MATLAB uses to draw and erase objects. Use alternative erase modes for creating animated sequences, where control of the way individual objects are redrawn is necessary to improve performance and obtain the desired effect.

- `normal` — Redraw the affected region of the display, performing the three-dimensional analysis necessary to correctly render all objects. This mode produces the most accurate picture, but is the slowest. The other modes are faster, but do not perform a complete redraw and are therefore less accurate.
- `none` — Do not erase the object when it is moved or destroyed. While the object is still visible on the screen after erasing with `EraseMode none`, you cannot print it because MATLAB stores no information about its former location.
- `xor` — Draw and erase the object by performing an exclusive OR (XOR) with the color of the screen beneath it. This mode does not damage the color of the objects beneath it. However,

Barseries Properties

the object's color depends on the color of whatever is beneath it on the display.

- **background** — Erase the object by redrawing it in the axes background `Color`, or the figure background `Color` if the axes `Color` property is `none`. This damages objects that are behind the erased object, but properly colors the erased object.

Set the axes background color with the axes `Color` property. Set the figure background color with the figure `Color` property.

Printing with Nonnormal Erase Modes

MATLAB always prints figures as if the `EraseMode` of all objects is `normal`. This means graphics objects created with `EraseMode` set to `none`, `xor`, or `background` can look different on screen than on paper. On screen, MATLAB mathematically combines layers of colors (for example, performing an XOR on a pixel color with that of the pixel behind it) and ignore three-dimensional sorting to obtain greater rendering speed. However, these techniques are not applied to the printed output.

You can use the `getframe` command or other screen capture applications to create an image of a figure containing nonnormal mode objects.

`FaceColor`

`{flat}` | `none` | `ColorSpec`

Color of filled areas.

- `ColorSpec` — A three-element RGB vector or one of the MATLAB predefined names, specifying a single color for all filled areas.
- `none` — Do not draw faces. Note that MATLAB draws `EdgeColor` independently of `FaceColor`.

- `flat` — The object uses the figure colormap to determine the color of the filled areas.

HandleVisibility

`{on} | callback | off`

Control access to object's handle. Determines when an object's handle is visible in its parent's list of children. `HandleVisibility` is useful for preventing command-line users from accidentally accessing objects that you need to protect for some reason.

- `on` — Handles are always visible.
- `callback` — Handles are visible from within callback routines or functions invoked by callback routines, but not from within functions invoked from the command line. This provides a means to protect GUIs from command-line users, while allowing callback routines to have access to object handles.
- `off` — Handles are invisible at all times. Use this option when a callback invokes a function that could damage the GUI (such as evaluating a user-typed string). This option temporarily hides its own handles during the execution of that function.

Functions Affected by Handle Visibility

When a handle is not visible in its parent's list of children, it cannot be returned by functions that obtain handles by searching the object hierarchy or querying handle properties. This includes `get`, `findobj`, `gca`, `gcf`, `gco`, `newplot`, `cla`, `clf`, and `close`.

Properties Affected by Handle Visibility

When a handle's visibility is restricted using `callback` or `off`, the object's handle does not appear in its parent's `Children` property, figures do not appear in the root's `CurrentFigure` property, objects do not appear in the root's `CallbackObject` property or in the figure's `CurrentObject` property, and axes do not appear in their parent's `CurrentAxes` property.

Barseries Properties

Overriding Handle Visibility

You can set the root `ShowHiddenHandles` property to `on` to make all handles visible regardless of their `HandleVisibility` settings. This does not affect the values of the `HandleVisibility` properties. See also `findall`.

Handle Validity

Hidden handles are still valid. If you know an object's handle, you can `set` and `get` its properties and pass it to any function that operates on handles.

Note If you change one data source property to a variable that contains data of a different dimension, you might cause the function to generate a warning and not render the graph until you have changed all data source properties to appropriate values.

HitTest

`{on}` | `off`

Selectable by mouse click. Determines whether this object can become the current object (as returned by the `gco` command and the figure `CurrentObject` property) as a result of a mouse click on the objects that compose the bar graph. If `HitTest` is `off`, clicking this object selects the object below it (which is usually the axes containing it).

HitTestArea

`on` | `{off}`

Select barseries object on bars or area of extent. This property enables you to select barseries objects in two ways:

- Select by clicking bars (default).

- Select by clicking anywhere in the extent of the bar graph.

When `HitTestArea` is off, you must click the bars to select the `barseries` object. When `HitTestArea` is on, you can select the `barseries` object by clicking anywhere within the extent of the bar graph (that is, anywhere within a rectangle that encloses all the bars).

`Interruptible`
off | {on}

Callback routine interruption

Controls whether MATLAB can interrupt an object's callback function when subsequent callbacks attempt to interrupt it.

For Graphics objects, the `Interruptible` property affects only the callbacks for the `ButtonDownFcn` property. A *running* callback is the currently executing callback. The *interrupting* callback is the callback that tries to interrupt the *running* callback. MATLAB handles both the callbacks based on the `Interruptible` property of the object of the *running* callback.

When the `Interruptible` property is set to:

- 'off', MATLAB finishes execution of the *running* callback without any interruptions
- 'on', these conditions apply:
 - If there is a `drawnow`, `figure`, `getframe`, `waitfor`, or `pause` command in the *running* callback, then MATLAB executes the *interrupting* callbacks which are already in the queue and returns to finish execution of the current callback.
 - If one of the above functions is not in the *running* callback, then MATLAB finishes execution of the current callback without any interruption.

Barseries Properties

BusyAction property of the object of interrupting callback determines whether the callback should be ignored or should be put in the queue.

Setting Interruptible property to on (default), allows a callback from other graphics objects to interrupt callback functions originating from this object.

Note MATLAB does not save the state of properties or the display when an interruption occurs. For example, the handle returned by the gca or(gcf) command may be changed as another callback is executed.

After the function that interrupts a callback completes, the callback resumes execution where it halted when interrupted. For more information, see “Control Callback Execution and Interruption”.

LineStyle

{-} | -- | : | -. | none

Line style of barseries object.

Line Style Specifiers Table

Specifier	Line Style
'-'	Solid line (default)
'--'	Dashed line
':'	Dotted line
'-.'	Dash-dot line
'none'	No line

LineWidth

size in points

Width of linear objects and edges of filled areas. Specify in points. 1 point = $1/72$ inch. The default is 0.5 points.

Parent

handle of parent axes, hggroup, or hgtransform

Parent of object. Handle of the object's parent. The parent is normally the axes, hggroup, or hgtransform object that contains the object.

Selected

on | {off}

Object selection state. When you set this property to on, MATLAB displays selection handles at the corners and midpoints if the SelectionHighlight property is also on (the default). You can, for example, define the ButtonDownFcn callback to set this property to on, thereby indicating that this particular object is selected. This property is also set to on when an object is manually selected in plot edit mode.

SelectionHighlight

{on} | off

Object highlighted when selected.

- on — MATLAB indicates the selected state by drawing four edge handles and four corner handles.
- off — MATLAB does not draw the handles except when in plot edit mode and objects are selected manually.

ShowBaseLine

{on} | off

Barseries Properties

Turn baseline display on or off. This property determines whether bar plots display a baseline from which the bars are drawn. By default, the baseline is displayed.

Tag

string

User-specified object label. Provides a means to identify graphics objects with a user-specified label. The default is an empty string.

Use the Tag property and the `findobj` function to manipulate specific objects within a plotting hierarchy.

For example, create a barseries object and set the Tag property:

```
t = bar(Y, 'Tag', 'bar1')
```

To access the barseries object, use `findobj` to find the barseries object's handle. The following statement changes the `FaceColor` property of the object whose Tag is bar1.

```
set(findobj('Tag', 'bar1'), 'FaceColor', 'red')
```

Type

string (read-only)

Type of graphics object. String that identifies the class of the graphics object. Use this property to find all objects of a given type within a plotting hierarchy. For barseries objects, Type is 'hggroup'.

The following statement finds all the hggroup objects in the current axes.

```
t = findobj(gca, 'Type', 'hggroup');
```

UIContextMenu

handle of uicontextmenu object

Associate context menu with object. Handle of a `uicontextmenu` object created in the object's parent figure. Use the `uicontextmenu` function to create the context menu. MATLAB displays the context menu whenever you right-click over the object. The default value is an empty array.

UserData
array

User-specified data. Data you want to associate with this object (including cell arrays and structures). The default value is an empty array. MATLAB does not use this data, but you can access it using the `set` and `get` commands.

Visible
{on} | off

Visibility of object and its children.

- **on** — Object and all children of the object are visible unless the child object's **Visible** property is **off**.
- **off** — Object not displayed. However, the object still exists and you can set and query its properties.

XData
array

Location of bars. The *x*-axis intervals for the vertical bars or *y*-axis intervals for horizontal bars (as specified by the *X* input argument). If *YData* is a vector, *XData* must be the same size. If *YData* is a matrix, the length of *XData* must be equal to the number of rows in *YData*.

XDataMode
{auto} | manual

Use automatic or user-specified x-axis values. If you specify *XData* (by setting the *XData* property or specifying the *X* input

Barseries Properties

argument), MATLAB sets this property to `manual` and uses the specified values to label the *x*-axis.

If you set `XDataMode` to `auto` after specifying `XData`, MATLAB resets the *x*-axis ticks to `1:size(YData,1)` or to the column indices of the `ZData`, overwriting any previous values for `XData`.

`XDataSource`

MATLAB variable, as a string

Link XData to MATLAB variable. Set this property to a MATLAB variable that is evaluated in the base workspace to generate the `XData`. The default value is an empty array.

```
set(h, 'XDataSource', 'xdatavariablename')
```

MATLAB requires a call to `refreshdata` when you set this property. Changing workspace variables used as an object's `XDataSource` does not change the object's `XData` values, but you can use `refreshdata` to force an update of the object's data. `refreshdata` also lets you specify that the data source variable be evaluated in the workspace of a function from which you call `refreshdata`.

Note If you change one data source property to a variable that contains data of a different dimension, you might cause the function to generate a warning and not render the graph until you have changed all data source properties to appropriate values.

`YData`

scalar | vector | matrix

Bar plot data. `YData` contains the data plotted as bars (the *Y* input argument). Each value in `YData` is represented by a bar in the bar graph. If `XYData` is a matrix, the `bar` function creates a "group"

or a "stack" of bars for each column in the matrix. See the bar reference page for examples of grouped and stacked bar graphs.

The input argument *Y* in the bar function calling syntax assigns values to *YData*.

YDataSource

MATLAB variable, as a string

Link YData to MATLAB variable. Set this property to a MATLAB variable that is evaluated in the base workspace to generate the *YData*. The default value is an empty array.

```
set(h, 'YDataSource', 'Ydatavariablename')
```

MATLAB requires a call to `refreshdata` when you set this property. Changing workspace variables used as an object's *YDataSource* does not change the object's *YData* values, but you can use `refreshdata` to force an update of the object's data. `refreshdata` also lets you specify that the data source variable be evaluated in the workspace of a function from which you call `refreshdata`.

Note If you change one data source property to a variable that contains data of a different dimension, you might cause the function to generate a warning and not render the graph until you have changed all data source properties to appropriate values.

How To

- “Types of Bar Graphs”
- “Plot Objects”
- “Setting Default Property Values”
- “Customize Objects in Graph”

TriRep.baryToCart

Purpose (Will be removed) Convert point coordinates from barycentric to Cartesian

Note `baryToCart(TriRep)` will be removed in a future release. Use `barycentricToCartesian(triangulation)` instead.

`TriRep` will be removed in a future release. Use `triangulation` instead.

Syntax `XC = baryToCart(TR, SI, B)`

Description `XC = baryToCart(TR, SI, B)` returns the Cartesian coordinates `XC` of each point in `B` that represents the barycentric coordinates with respect to its associated simplex `SI`.

Input Arguments

TR	Triangulation representation.
SI	Column vector of simplex indices that index into the triangulation matrix <code>TR.Triangulation</code>
B	<code>B</code> is a matrix that represents the barycentric coordinates of the points to convert with respect to the simplices <code>SI</code> . <code>B</code> is of size <code>m-by-k</code> , where <code>m = length(SI)</code> , the number of points to convert, and <code>k</code> is the number of vertices per simplex.

Output Arguments

XC	Matrix of cartesian coordinates of the converted points. <code>XC</code> is of size <code>m-by-n</code> , where <code>n</code> is the dimension of the space where the triangulation resides. That is, the Cartesian coordinates of the point <code>B(j)</code> with respect to simplex <code>SI(j)</code> is <code>XC(j)</code> .
----	--

Definitions A simplex is a triangle/tetrahedron or higher-dimensional equivalent.

Examples

Compute the Delaunay triangulation of a set of points.

```
x = [0 4 8 12 0 4 8 12]';
y = [0 0 0 0 8 8 8 8]';
dt = DelaunayTri(x,y)
```

Compute the barycentric coordinates of the incenters.

```
cc = incenters(dt);
tri = dt(:,:);
```

Plot the original triangulation and reference points.

```
figure
subplot(1,2,1);
triplot(dt); hold on;
plot(cc(:,1), cc(:,2), '*r'); hold off;
axis equal;
```

Stretch the triangulation and compute the mapped locations of the incenters on the deformed triangulation.

```
b = cartToBary(dt,[1:length(tri)]',cc);
y = [0 0 0 0 16 16 16 16]';
tr = TriRep(tri,x,y)
xc = baryToCart(tr, [1:length(tri)]', b);
```

Plot the deformed triangulation and mapped locations of the reference points.

```
subplot(1,2,2);
triplot(tr); hold on;
plot(xc(:,1), xc(:,2), '*r'); hold off;
axis equal;
```

TriRep.baryToCart

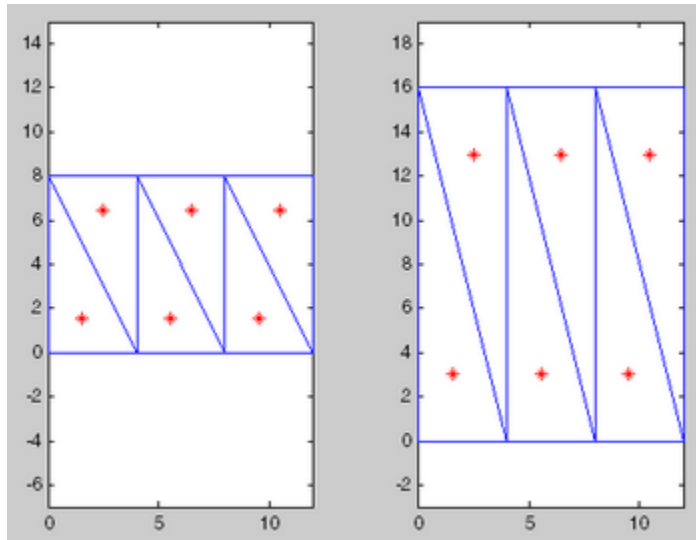

See Also

[cartesianToBarycentric](#) | [pointLocation](#) | [delaunayTriangulation](#)
| [triangulation](#)

Purpose Convert base N number string to decimal number

Syntax `d = base2dec('strn', base)`

Description `d = base2dec('strn', base)` converts the string number *strn* of the specified base into its decimal (base 10) equivalent. *base* must be an integer between 2 and 36. If *'strn'* is a character array, each row is interpreted as a string in the specified base.

Examples The expression `base2dec('212',3)` converts 212_3 to decimal, returning 23.

See Also `dec2base`

beep

Purpose Produce operating system beep sound

Syntax

```
beep
beep on
beep off

status = beep
```

Description beep produces your computer's default beep sound, if it is enabled.

beep on turns the beep on.

beep off turns the beep off.

status = beep returns the current beep mode (on or off).

Examples **Produce Beep Sound**

Produce your system's default beep sound after a period of silence.

Pause for 5 seconds of silence, and then produce your system's default beep sound.

```
pause(5)
beep
```

Tips

- If you have configured your system not to produce any sound, then beep is silent.
- beep produces the operating system's default beep sound. To produce a sound and specify its pitch and duration in MATLAB, use the sound function.

See Also sound

Purpose	Initiate asynchronous .NET delegate call
Syntax	<code>result = BeginInvoke(arg1, ..., argN, callback, object)</code>
Description	<code>result = BeginInvoke(arg1, ..., argN, callback, object)</code> initiates asynchronous call to a .NET delegate. You must call <code>EndInvoke</code> to complete the asynchronous call.
Input Arguments	<p>arg1, ..., argN Input arguments for delegate. The type and number of arguments must agree with the delegate signature.</p> <p>callback .NET <code>System.AsyncCallback</code> delegate, or [] null value.</p> <p>object User-defined object, or [] null value.</p>
Output Arguments	<p>result .NET <code>System.IAsyncResult</code> object. Used to monitor the progress of the asynchronous call. Input argument to <code>EndInvoke</code>.</p>
See Also	<code>EndInvoke</code>
How To	<ul style="list-style-type: none">• “Calling .NET Methods Asynchronously”
Related Links	<ul style="list-style-type: none">• MSDN® Calling Synchronous Methods Asynchronously

bench

Purpose MATLAB benchmark

Syntax
bench
bench(N)
bench(0)
t = bench(N)

Description bench times six different MATLAB tasks and compares the execution speed with the speed of several other computers. The six tasks are:

Test	Description	Performance Factors
LU	Perform LU of a full matrix	Floating-point, regular memory access
FFT	Perform FFT of a full vector	Floating-point, irregular memory access
ODE	Solve van der Pol equation with ODE45	Data structures and MATLAB function files
Sparse	Solve a symmetric sparse linear system	Mixed integer and floating-point
2-D	Plot Bernstein polynomial graph	2-D line drawing graphics
3-D	Display animated L-shape membrane logo	3-D animated OpenGL graphics

A final bar chart shows speed, which is inversely proportional to time. The longer bars represent faster machines, and the shorter bars represent the slower ones.

bench(N) runs each of the six tasks N times.

bench(0) just displays the results from other machines.

t = bench(N) returns an N-by-6 array with the execution times.

Tips

Note A benchmark is intended to compare performance of one particular version of MATLAB on different machines. It does not offer direct comparisons between different versions of MATLAB as tasks and problem sizes change from version to version.

The LU and FFT tasks involve large matrices and long vectors. The 2-D and 3-D tasks measure graphics performance, including software or hardware support for OpenGL. The command

```
opengl info
```

describes the OpenGL support available on a particular machine.

Fluctuations of five or ten percent in the measured times of repeated runs on a single machine are not uncommon. Your own mileage may vary.

See Also

```
profile | profsave | mlint | mlintrpt | memory | pack | tic |  
cputime | rehash
```

besselh

Purpose Bessel function of third kind (Hankel function)

Syntax
H = besselh(nu,K,Z)
H = besselh(nu,Z)
H = besselh(nu,K,Z,1)

Definitions The differential equation

$$z^2 \frac{d^2 y}{dz^2} + z \frac{dy}{dz} + (z^2 - \nu^2) y = 0,$$

where ν is a real constant, is called *Bessel's equation*, and its solutions are known as *Bessel functions*. $J_\nu(z)$ and $J_{-\nu}(z)$ form a fundamental set of solutions of Bessel's equation for noninteger ν . $Y_\nu(z)$ is a second solution of Bessel's equation—linearly independent of $J_\nu(z)$ —defined by

$$Y_\nu(z) = \frac{J_\nu(z) \cos(\nu\pi) - J_{-\nu}(z)}{\sin(\nu\pi)}.$$

The relationship between the Hankel and Bessel functions is

$$H_\nu^{(1)}(z) = J_\nu(z) + iY_\nu(z)$$

$$H_\nu^{(2)}(z) = J_\nu(z) - iY_\nu(z),$$

where $J_\nu(z)$ is `besselj`, and $Y_\nu(z)$ is `bessely`.

Description H = besselh(nu,K,Z) computes the Hankel function $H_\nu^{(K)}(z)$ where K = 1 or 2, for each element of the complex array Z. If nu and Z are arrays of the same size, the result is also that size. If either input is a scalar, besselh expands it to the other input's size.

H = besselh(nu,Z) uses K = 1.

H = besselh(nu,K,Z,1) scales $H_\nu^{(K)}(z)$ by $\exp(-i*Z)$ if K = 1, and by $\exp(+i*Z)$ if K = 2.

Examples**Modulus and Phase of Hankel Function**

This example generates the contour plots of the modulus and phase of the Hankel function $H_0^{(1)}(z)$ shown on page 359 of Abramowitz and Stegun, *Handbook of Mathematical Functions* [1].

Create a grid of values for the domain.

```
[X,Y] = meshgrid(-4:0.025:2,-1.5:0.025:1.5);
```

Calculate the Hankel function over this domain and generate the modulus contour plot.

```
H = besselh(0,1,X+1i*Y);  
contour(X,Y,abs(H),0:0.2:3.2), hold on
```

besselh

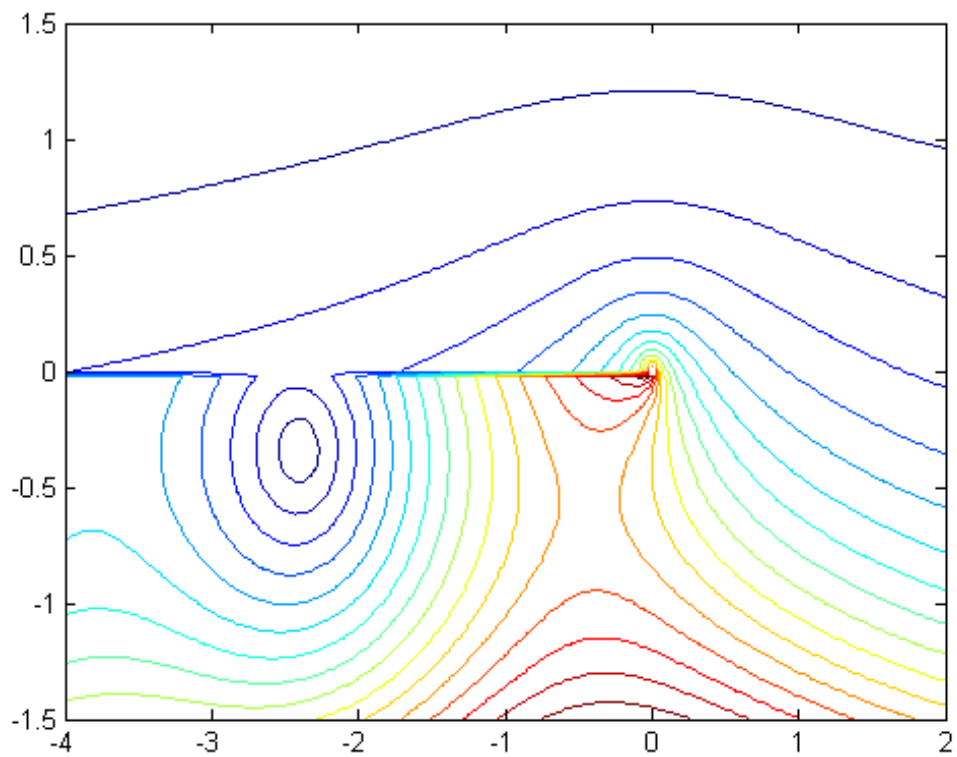

In the same figure, add the contour plot of the phase.

```
contour(X,Y,(180/pi)*angle(H),-180:10:180); hold off
```

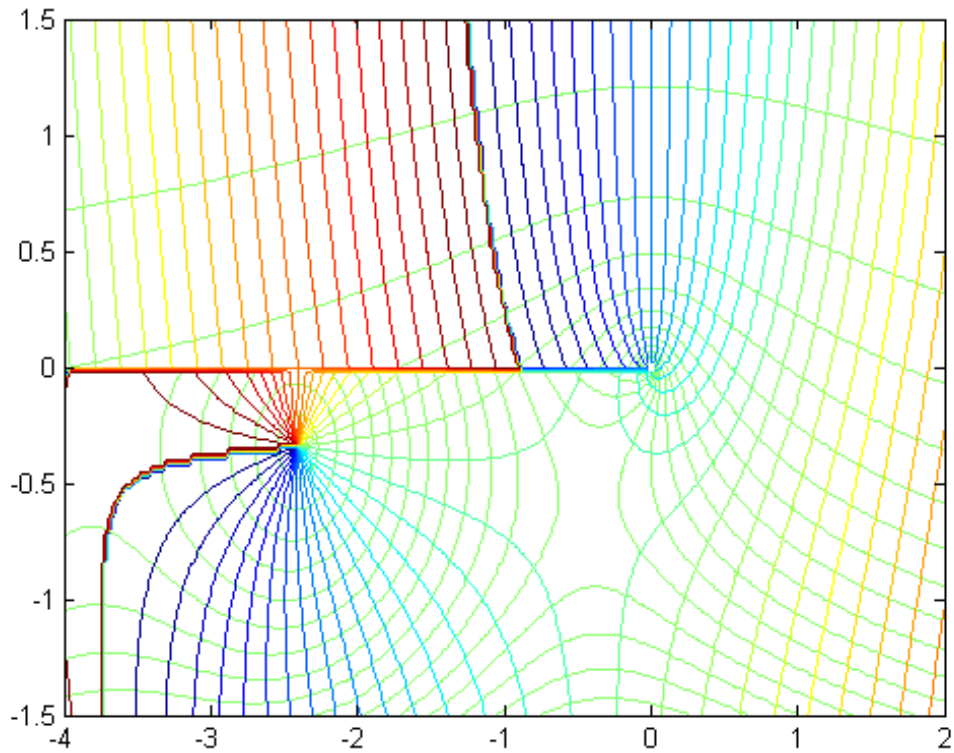
**References**

[1] Abramowitz, M., and I.A. Stegun, *Handbook of Mathematical Functions*, National Bureau of Standards, Applied Math. Series #55, Dover Publications, 1965.

See Also

besselj | bessely | besseli | besselk

besseli

Purpose Modified Bessel function of first kind

Syntax
`I = besseli(nu,Z)`
`I = besseli(nu,Z,1)`

Definitions The differential equation

$$z^2 \frac{d^2 y}{dz^2} + z \frac{dy}{dz} - (z^2 + \nu^2) y = 0,$$

where ν is a real constant, is called the *modified Bessel's equation*, and its solutions are known as *modified Bessel functions*.

$I_\nu(z)$ and $I_{-\nu}(z)$ form a fundamental set of solutions of the modified Bessel's equation. $I_\nu(z)$ is defined by

$$I_\nu(z) = \left(\frac{z}{2}\right)^\nu \sum_{(k=0)}^{\infty} \frac{\left(\frac{z^2}{4}\right)^k}{k! \Gamma(\nu + k + 1)},$$

where $\Gamma(a)$ is the gamma function.

$K_\nu(z)$ is a second solution, independent of $I_\nu(z)$. It can be computed using `besselk`.

Description `I = besseli(nu,Z)` computes the modified Bessel function of the first kind, $I_\nu(z)$, for each element of the array `Z`. The order `nu` need not be an integer, but must be real. The argument `Z` can be complex. The result is real where `Z` is positive.

If `nu` and `Z` are arrays of the same size, the result is also that size. If either input is a scalar, it is expanded to the other input's size.

`I = besseli(nu,Z,1)` computes `besseli(nu,Z) .* exp(-abs(real(Z)))`.

Examples**Vector of Function Values**

Create a column vector of domain values.

```
z = (0:0.2:1)';
```

Calculate the function values using `besseli` with `nu = 1`.

```
format long  
besselk(1,z)
```

```
ans =
```

```
                                Inf  
4.775972543220472  
2.184354424732687  
1.302834939763502  
0.861781634472180  
0.601907230197235
```

Plot Modified Bessel Functions of First Kind

Define the domain.

```
X = 0:0.01:5;
```

Calculate the first five modified Bessel functions of the first kind.

```
I = zeros(5,501);  
for i=0:4  
    I(i+1,:) = besseli(i,X);  
end
```

Plot the results.

```
plot(X,I,'LineWidth',1.5)
```

besseli

```
axis([0 5 0 8])
grid on;
legend('I_0','I_1','I_2','I_3','I_4','Location','Best')
title('Modified Bessel Functions of the First Kind for v = 0,1,2,3,4')
xlabel('X')
ylabel('I_v(X)')
```

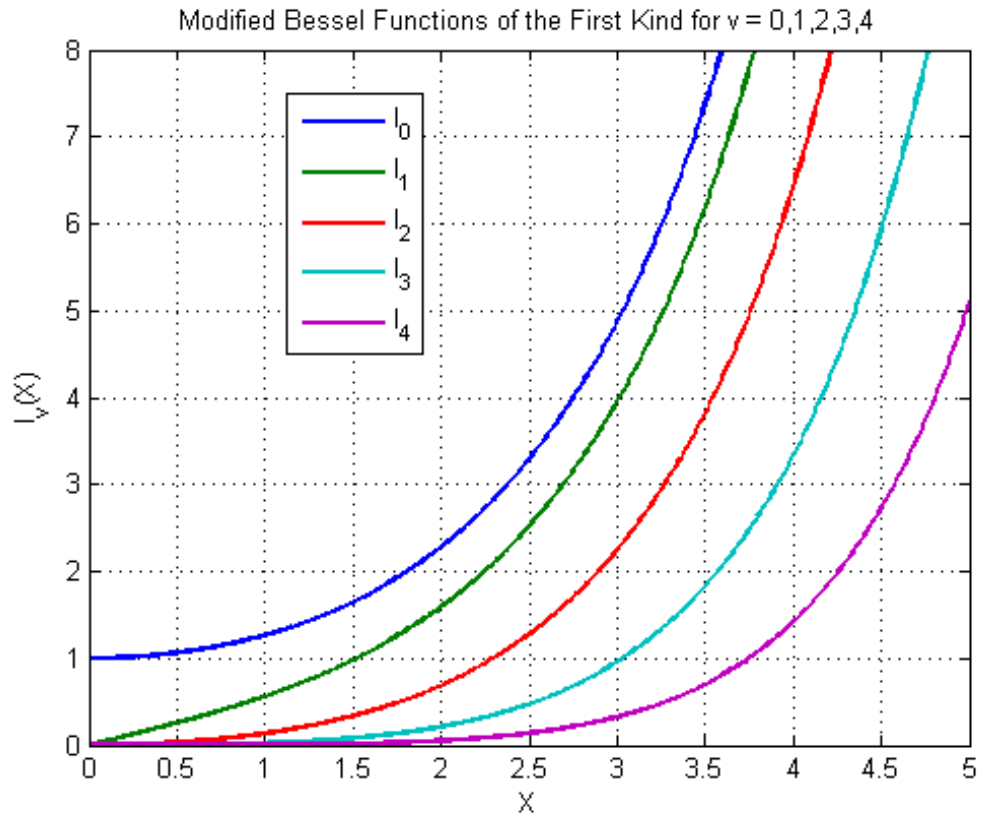

Algorithms

The `besseli` functions use a Fortran MEX-file to call a library developed by D.E. Amos [3] [4].

References

- [1] Abramowitz, M., and I.A. Stegun, *Handbook of Mathematical Functions*, National Bureau of Standards, Applied Math. Series #55, Dover Publications, 1965, sections 9.1.1, 9.1.89, and 9.12, formulas 9.1.10 and 9.2.5.
- [2] Carrier, Krook, and Pearson, *Functions of a Complex Variable: Theory and Technique*, Hod Books, 1983, section 5.5.
- [3] Amos, D.E., "A Subroutine Package for Bessel Functions of a Complex Argument and Nonnegative Order," *Sandia National Laboratory Report*, SAND85-1018, May, 1985.
- [4] Amos, D.E., "A Portable Package for Bessel Functions of a Complex Argument and Nonnegative Order," *Trans. Math. Software*, 1986.

See Also

`airy` | `besselh` | `besselj` | `besselk` | `bessely`

besselj

Purpose Bessel function of first kind

Syntax
`J = besselj(nu,Z)`
`J = besselj(nu,Z,1)`

Definitions The differential equation

$$z^2 \frac{d^2 y}{dz^2} + z \frac{dy}{dz} + (z^2 - \nu^2) y = 0,$$

where ν is a real constant, is called *Bessel's equation*, and its solutions are known as *Bessel functions*.

$J_\nu(z)$ and $J_{-\nu}(z)$ form a fundamental set of solutions of Bessel's equation for noninteger ν . $J_\nu(z)$ is defined by

$$J_\nu(z) = \left(\frac{z}{2}\right)^\nu \sum_{(k=0)}^{\infty} \frac{\left(\frac{-z^2}{4}\right)^k}{k! \Gamma(\nu + k + 1)}$$

where $\Gamma(a)$ is the gamma function.

$Y_\nu(z)$ is a second solution of Bessel's equation that is linearly independent of $J_\nu(z)$. It can be computed using `bessely`.

Description `J = besselj(nu,Z)` computes the Bessel function of the first kind, $J_\nu(z)$, for each element of the array `Z`. The order `nu` need not be an integer, but must be real. The argument `Z` can be complex. The result is real where `Z` is positive.

If `nu` and `Z` are arrays of the same size, the result is also that size. If either input is a scalar, it is expanded to the other input's size.

`J = besselj(nu,Z,1)` computes `besselj(nu,Z) .* exp(-abs(imag(Z)))`.

Tips

The Bessel functions are related to the Hankel functions, also called Bessel functions of the third kind,

$$H_\nu^{(1)}(z) = J_\nu(z) + iY_\nu(z)$$

$$H_\nu^{(2)}(z) = J_\nu(z) - iY_\nu(z)$$

where $H_\nu^{(K)}(z)$ is `besselh`, $J_\nu(z)$ is `besselj`, and $Y_\nu(z)$ is `bessely`. The Hankel functions also form a fundamental set of solutions to Bessel's equation (see `besselh`).

Examples**Vector of Function Values**

Create a column vector of domain values.

```
z = (0:0.2:1)';
```

Calculate the function values using `besselj` with `nu = 1`.

```
format long
besselj(1,z)
```

```
ans =
```

```

           0
0.099500832639236
0.196026577955319
0.286700988063916
0.368842046094170
0.440050585744934
```

Plot Bessel Functions of First Kind

Define the domain.

```
X = 0:0.1:20;
```

Calculate the first five Bessel functions of the first kind.

besselj

```
J = zeros(5,201);
for i=0:4
    J(i+1,:) = besselj(i,X);
end
```

Plot the results.

```
plot(X,J,'LineWidth',1.5)
axis([0 20 -.5 1])
grid on;
legend('J_0','J_1','J_2','J_3','J_4','Location','Best')
title('Bessel Functions of the First Kind for  $\nu = 0,1,2,3,4$ ')
xlabel('X')
ylabel('J_v(X)')
```

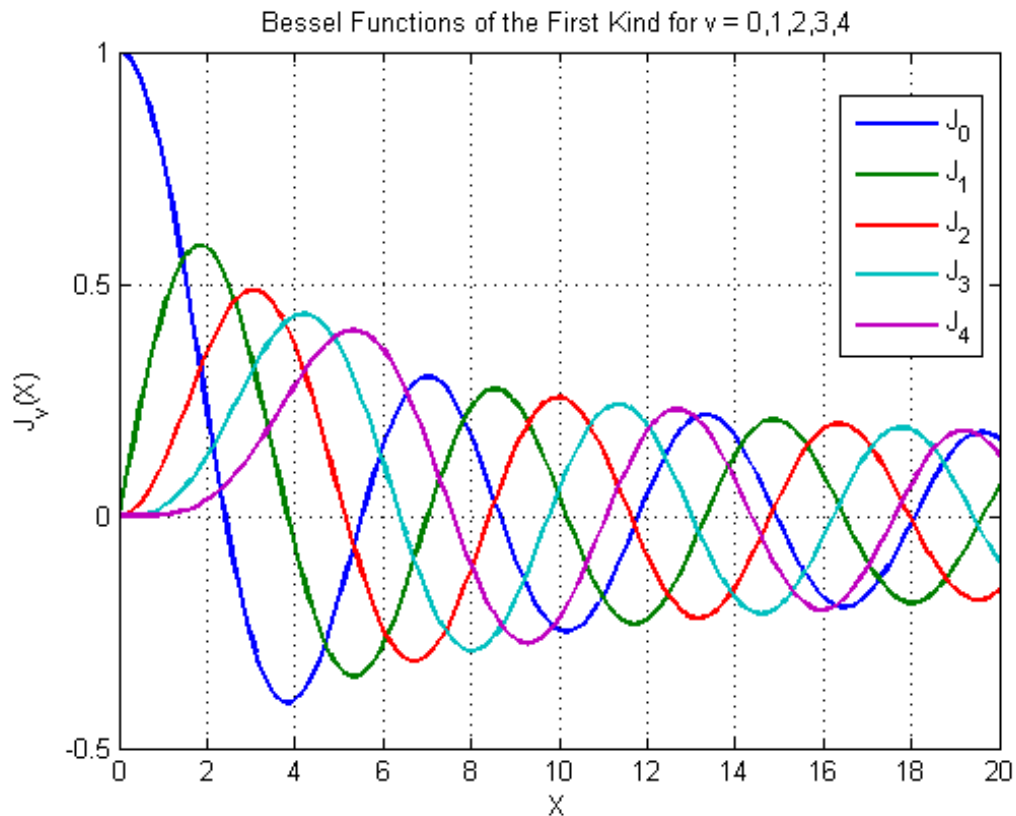

Algorithms

The `besselj` function uses a Fortran MEX-file to call a library developed by D.E. Amos [3] [4].

References

[1] Abramowitz, M., and I.A. Stegun, *Handbook of Mathematical Functions*, National Bureau of Standards, Applied Math. Series #55, Dover Publications, 1965, sections 9.1.1, 9.1.89, and 9.12, formulas 9.1.10 and 9.2.5.

[2] Carrier, Krook, and Pearson, *Functions of a Complex Variable: Theory and Technique*, Hod Books, 1983, section 5.5.

[3] Amos, D.E., "A Subroutine Package for Bessel Functions of a Complex Argument and Nonnegative Order," *Sandia National Laboratory Report*, SAND85-1018, May, 1985.

[4] Amos, D.E., "A Portable Package for Bessel Functions of a Complex Argument and Nonnegative Order," *Trans. Math. Software*, 1986.

See Also

besselh | besseli | besselk | bessely

Purpose Modified Bessel function of second kind

Syntax
`K = besselk(nu,Z)`
`K = besselk(nu,Z,1)`

Definitions The differential equation

$$z^2 \frac{d^2 y}{dz^2} + z \frac{dy}{dz} - (z^2 + \nu^2) y = 0,$$

where ν is a real constant, is called the *modified Bessel's equation*, and its solutions are known as *modified Bessel functions*.

A solution $K_\nu(z)$ of the second kind can be expressed as:

$$K_\nu(z) = \left(\frac{\pi}{2} \right) \frac{I_{-\nu}(z) - I_\nu(z)}{\sin(\nu\pi)},$$

where $I_\nu(z)$ and $I_{-\nu}(z)$ form a fundamental set of solutions of the modified Bessel's equation,

$$I_\nu(z) = \left(\frac{z}{2} \right)^\nu \sum_{k=0}^{\infty} \frac{\left(\frac{z^2}{4} \right)^k}{k! \Gamma(\nu + k + 1)}$$

and $\Gamma(a)$ is the gamma function. $K_\nu(z)$ is independent of $I_\nu(z)$.

$I_\nu(z)$ can be computed using `besseli`.

Description `K = besselk(nu,Z)` computes the modified Bessel function of the second kind, $K_\nu(z)$, for each element of the array Z . The order ν need not be an integer, but must be real. The argument Z can be complex. The result is real where Z is positive.

If ν and Z are arrays of the same size, the result is also that size. If either input is a scalar, it is expanded to the other input's size.

`K = besselk(nu,Z,1)` computes `besselk(nu,Z).*exp(Z)`.

Examples

Column Vector of Function Values

Create a column vector of domain values.

```
z = (0:0.2:1)';
```

Calculate the function values using `besselk` with `nu = 1`.

```
format long
besselk(1,z)
```

```
ans =
```

```

                Inf
4.775972543220472
2.184354424732687
1.302834939763502
0.861781634472180
0.601907230197235
```

Plot Modified Bessel Functions of Second Kind

Define the domain.

```
X = 0:0.01:5;
```

Calculate the first five modified Bessel functions of the second kind.

```
K = zeros(5,501);
for i=0:4
    K(i+1,:) = besselk(i,X);
end
```

Plot the results.

```
plot(X,K,'LineWidth',1.5)
axis([0 5 0 8])
grid on;
legend('K_0','K_1','K_2','K_3','K_4','Location','Best')
title('Modified Bessel Functions of the Second Kind for v = 0,1,2,3,4')
xlabel('X')
ylabel('K_v(X)')
```

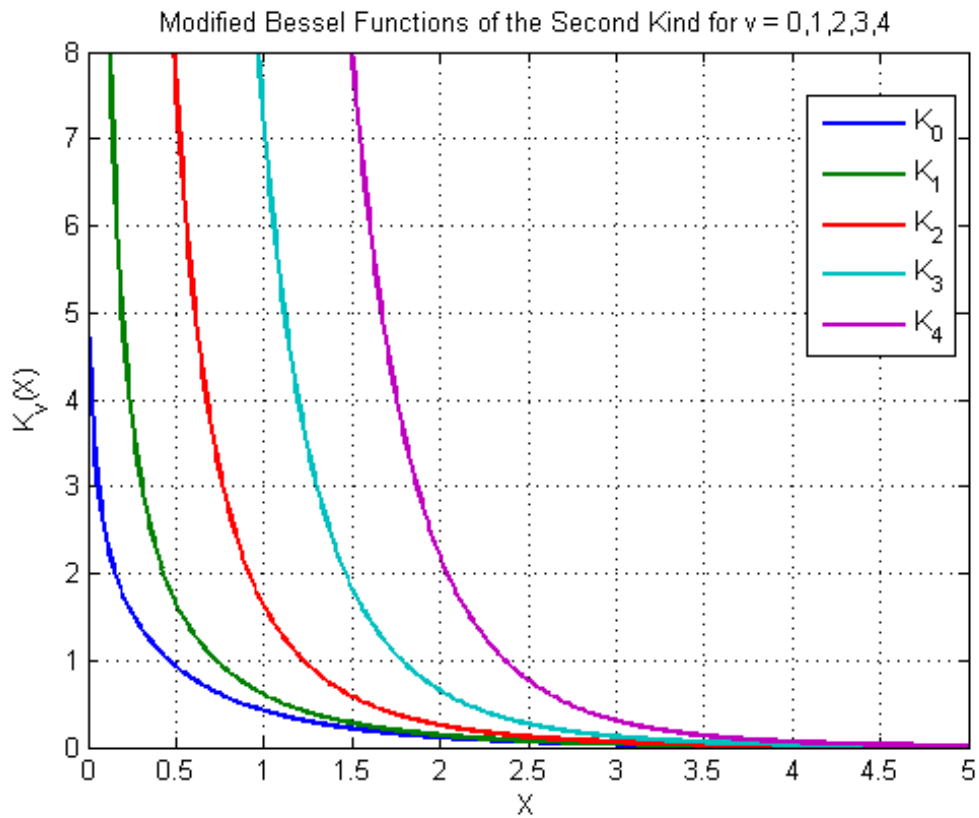

Algorithms

The `besselk` function uses a Fortran MEX-file to call a library developed by D.E. Amos [3], [4].

References

[1] Abramowitz, M., and I.A. Stegun, *Handbook of Mathematical Functions*, National Bureau of Standards, Applied Math. Series #55, Dover Publications, 1965, sections 9.1.1, 9.1.89, and 9.12, formulas 9.1.10 and 9.2.5.

[2] Carrier, Krook, and Pearson, *Functions of a Complex Variable: Theory and Technique*, Hod Books, 1983, section 5.5.

[3] Amos, D.E., "A Subroutine Package for Bessel Functions of a Complex Argument and Nonnegative Order," *Sandia National Laboratory Report*, SAND85-1018, May, 1985.

[4] Amos, D.E., "A Portable Package for Bessel Functions of a Complex Argument and Nonnegative Order," *Trans. Math. Software*, 1986.

See Also

`airy` | `besselh` | `besseli` | `besselj` | `bessely`

Purpose Bessel function of second kind

Syntax
`Y = bessely(nu,Z)`
`Y = bessely(nu,Z,1)`

Definitions The differential equation

$$z^2 \frac{d^2 y}{dz^2} + z \frac{dy}{dz} + (z^2 - \nu^2) y = 0,$$

where ν is a real constant, is called *Bessel's equation*, and its solutions are known as *Bessel functions*.

A solution $Y_\nu(z)$ of the second kind can be expressed as

$$Y_\nu(z) = \frac{J_\nu(z) \cos(\nu\pi) - J_{-\nu}(z)}{\sin(\nu\pi)}$$

where $J_\nu(z)$ and $J_{-\nu}(z)$ form a fundamental set of solutions of Bessel's equation for noninteger ν

$$J_\nu(z) = \left(\frac{z}{2}\right)^\nu \sum_{k=0}^{\infty} \frac{\left(-\frac{z^2}{4}\right)^k}{k! \Gamma(\nu + k + 1)},$$

and $\Gamma(a)$ is the gamma function. $Y_\nu(z)$ is linearly independent of $J_\nu(z)$.

$J_\nu(z)$ can be computed using `besselj`.

Description

`Y = bessely(nu,Z)` computes Bessel functions of the second kind, $Y_\nu(z)$, for each element of the array `Z`. The order `nu` need not be an integer, but must be real. The argument `Z` can be complex. The result is real where `Z` is positive.

If `nu` and `Z` are arrays of the same size, the result is also that size. If either input is a scalar, it is expanded to the other input's size.

bessely

```
Y = bessely(nu,Z,1) computes  
bessely(nu,Z).*exp(-abs(imag(Z))).
```

Tips

The Bessel functions are related to the Hankel functions, also called Bessel functions of the third kind,

$$H_v^{(1)}(z) = J_v(z) + iY_v(z)$$

$$H_v^{(2)}(z) = J_v(z) - iY_v(z),$$

where $H_v^{(K)}(z)$ is `besselh`, $J_v(z)$ is `besselj`, and $Y_v(z)$ is `bessely`. The Hankel functions also form a fundamental set of solutions to Bessel's equation (see `besselh`).

Examples

Vector of Function Values

Create a column vector of domain values.

```
z = (0:0.2:1)';
```

Calculate the function values using `bessely` with `nu = 1`.

```
format long  
bessely(1,z)
```

```
ans =
```

```
          - Inf  
-3.323824988111848  
-1.780872044270052  
-1.260391347177388  
-0.978144176683359  
-0.781212821300289
```

Plot Bessel Functions of Second Kind

Define the domain.

```
X = 0:0.1:20;
```

Calculate the first five Bessel functions of the second kind.

```
Y = zeros(5,201);  
for i=0:4  
    Y(i+1,:) = bessely(i,X);  
end
```

Plot the results.

```
plot(X,Y,'LineWidth',1.5)  
axis([-0.1 20.2 -2 0.6])  
grid on;  
legend('Y_0','Y_1','Y_2','Y_3','Y_4','Location','Best')  
title('Bessel Functions of the Second Kind for  $\nu = 0,1,2,3,4$ ')  
xlabel('X')  
ylabel('Y_v(X)')
```

bessely

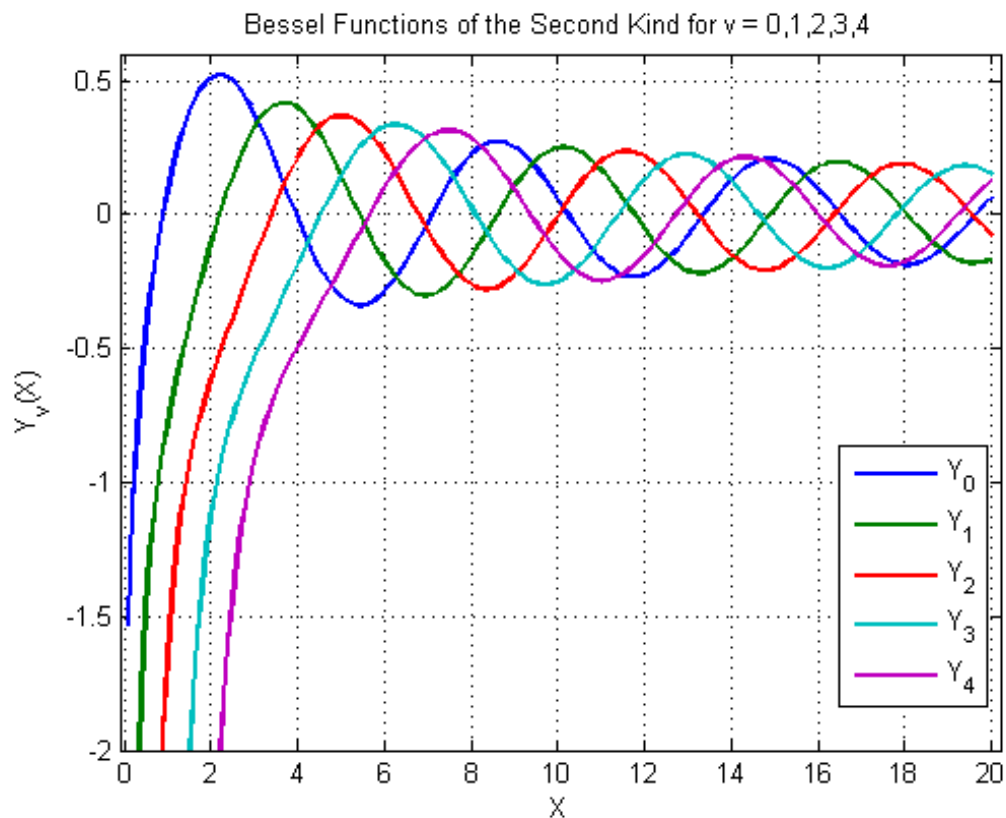

Algorithms

The `bessely` function uses a Fortran MEX-file to call a library developed by D. E Amos [3] [4].

References

[1] Abramowitz, M., and I.A. Stegun, *Handbook of Mathematical Functions*, National Bureau of Standards, Applied Math. Series #55, Dover Publications, 1965, sections 9.1.1, 9.1.89, and 9.12, formulas 9.1.10 and 9.2.5.

[2] Carrier, Krook, and Pearson, *Functions of a Complex Variable: Theory and Technique*, Hod Books, 1983, section 5.5.

[3] Amos, D.E., "A Subroutine Package for Bessel Functions of a Complex Argument and Nonnegative Order," *Sandia National Laboratory Report*, SAND85-1018, May, 1985.

[4] Amos, D.E., "A Portable Package for Bessel Functions of a Complex Argument and Nonnegative Order," *Trans. Math. Software*, 1986.

See Also

besselh | besseli | besselj | besserk

Purpose Beta function

Syntax B = beta(Z,W)

Definitions The beta function is

$$B(z,w) = \int_0^1 t^{z-1} (1-t)^{w-1} dt = \frac{\Gamma(z)\Gamma(w)}{\Gamma(z+w)}$$

where $\Gamma(z)$ is the gamma function.

Description B = beta(Z,W) computes the beta function for corresponding elements of arrays Z and W. The arrays must be real and nonnegative. They must be the same size, or either can be scalar.

Examples In this example, which uses integer arguments,

```
beta(n,3)
= (n-1)!*2!/(n+2)!
= 2/(n*(n+1)*(n+2))
```

is the ratio of fairly small integers, and the rational format is able to recover the exact result.

```
format rat
beta((0:10)',3)
```

```
ans =

    1/0
    1/3
    1/12
    1/30
    1/60
    1/105
    1/168
    1/252
```

1/360

1/495

1/660

Algorithms

`beta(z,w) = exp(gammaIn(z)+gammaIn(w)-gammaIn(z+w))`

See Also

`betainc` | `betaIn` | `gammaIn`

betainc

Purpose Incomplete beta function

Syntax
`I = betainc(X,Z,W)`
`I = betainc(X,Z,W,tail)`

Definitions The incomplete beta function is

$$I_x(z,w) = \frac{1}{B(z,w)} \int_0^x t^{z-1} (1-t)^{w-1} dt$$

where $B(z,w)$, the beta function, is defined as

$$B(z,w) = \int_0^1 t^{z-1} (1-t)^{w-1} dt = \frac{\Gamma(z)\Gamma(w)}{\Gamma(z+w)}$$

and $\Gamma(z)$ is the gamma function.

Description `I = betainc(X,Z,W)` computes the incomplete beta function for corresponding elements of the arrays `X`, `Z`, and `W`. The elements of `X` must be in the closed interval $[0,1]$. The arrays `Z` and `W` must be nonnegative and real. All arrays must be the same size, or any of them can be scalar.

`I = betainc(X,Z,W,tail)` specifies the tail of the incomplete beta function. Choices are:

'lower' (the default)	Computes the integral from 0 to x
'upper'	Computes the integral from x to 1

These functions are related as follows:

$$1 - \text{betainc}(X,Z,W) = \text{betainc}(X,Z,W, \text{'upper'})$$

Note that especially when the upper tail value is close to 0, it is more accurate to use the 'upper' option than to subtract the 'lower' value from 1.

Examples

```
format long  
betainc(.5, (0:10)', 3)
```

```
ans =  
1.000000000000000  
0.875000000000000  
0.687500000000000  
0.500000000000000  
0.343750000000000  
0.226562500000000  
0.144531250000000  
0.089843750000000  
0.054687500000000  
0.032714843750000  
0.019287109375000
```

See Also

[beta](#) | [betaIn](#)

betaincinv

Purpose Beta inverse cumulative distribution function

Syntax
`x = betaincinv(y,z,w)`
`x = betaincinv(y,z,w,tail)`

Description `x = betaincinv(y,z,w)` computes the inverse incomplete beta function for corresponding elements of `y`, `z`, and `w`, such that `y = betainc(x,z,w)`. The elements of `y` must be in the closed interval `[0,1]`, and those of `z` and `w` must be nonnegative. `y`, `z`, and `w` must all be real and the same size (or any of them can be scalar).

`x = betaincinv(y,z,w,tail)` specifies the tail of the incomplete beta function. Choices are 'lower' (the default) to use the integral from 0 to `x`, or 'upper' to use the integral from `x` to 1. These two choices are related as follows: `betaincinv(y,z,w,'upper') = betaincinv(1-y,z,w,'lower')`. When `y` is close to 0, the 'upper' option provides a way to compute `x` more accurately than by subtracting from `y` from 1.

Definitions The incomplete beta function is defined as

$$I_x(z,w) = \frac{1}{\beta(z,w)} \int_0^x t^{z-1} (1-t)^{w-1} dt$$

`betaincinv` computes the inverse of the incomplete beta function with respect to the integration limit `x` using Newton's method.

See Also `betainc` | `beta` | `betaln`

Purpose	Logarithm of beta function
Syntax	<code>L = betaIn(Z,W)</code>
Description	<p><code>L = betaIn(Z,W)</code> computes the natural logarithm of the beta function <code>log(beta(Z,W))</code>, for corresponding elements of arrays <code>Z</code> and <code>W</code>, without computing <code>beta(Z,W)</code>. Since the beta function can range over very large or very small values, its logarithm is sometimes more useful.</p> <p><code>Z</code> and <code>W</code> must be real and nonnegative. They must be the same size, or either can be scalar.</p>
Examples	<pre>x = 510 betaIn(x,x) ans = -708.8616</pre> <p><code>-708.8616</code> is slightly less than <code>log(realmin)</code>. Computing <code>beta(x,x)</code> directly would underflow (or be denormal).</p>
Algorithms	<code>betaIn(z,w) = gammaIn(z)+gammaIn(w)-gammaIn(z+w)</code>
See Also	<code>beta</code> <code>betainc</code> <code>gammaIn</code>

Purpose

Biconjugate gradients method

Syntax

```
x = bicg(A,b)
bicg(A,b,tol)
bicg(A,b,tol,maxit)
bicg(A,b,tol,maxit,M)
bicg(A,b,tol,maxit,M1,M2)
bicg(A,b,tol,maxit,M1,M2,x0)
[x,flag] = bicg(A,b,...)
[x,flag,relres] = bicg(A,b,...)
[x,flag,relres,iter] = bicg(A,b,...)
[x,flag,relres,iter,resvec] = bicg(A,b,...)
```

Description

`x = bicg(A,b)` attempts to solve the system of linear equations $A*x = b$ for x . The n -by- n coefficient matrix A must be square and should be large and sparse. The column vector b must have length n . A can be a function handle, `afun`, such that `afun(x, 'notransp')` returns $A*x$ and `afun(x, 'transp')` returns $A'*x$.

“Parameterizing Functions” explains how to provide additional parameters to the function `afun`, as well as the preconditioner function `mfun` described below, if necessary.

If `bicg` converges, it displays a message to that effect. If `bicg` fails to converge after the maximum number of iterations or halts for any reason, it prints a warning message that includes the relative residual $\text{norm}(b-A*x)/\text{norm}(b)$ and the iteration number at which the method stopped or failed.

`bicg(A,b,tol)` specifies the tolerance of the method. If `tol` is `[]`, then `bicg` uses the default, $1e-6$.

`bicg(A,b,tol,maxit)` specifies the maximum number of iterations. If `maxit` is `[]`, then `bicg` uses the default, $\min(n,20)$.

`bicg(A,b,tol,maxit,M)` and `bicg(A,b,tol,maxit,M1,M2)` use the preconditioner M or $M = M1*M2$ and effectively solve the system $\text{inv}(M)*A*x = \text{inv}(M)*b$ for x . If M is `[]` then `bicg` applies

no preconditioner. M can be a function handle `mfun`, such that `mfun(x, 'notransp')` returns $M \backslash x$ and `mfun(x, 'transp')` returns $M' \backslash x$.

`bicg(A,b,tol,maxit,M1,M2,x0)` specifies the initial guess. If x_0 is `[]`, then `bicg` uses the default, an all-zero vector.

`[x,flag] = bicg(A,b,...)` also returns a convergence flag.

Flag	Convergence
0	<code>bicg</code> converged to the desired tolerance <code>tol</code> within <code>maxit</code> iterations.
1	<code>bicg</code> iterated <code>maxit</code> times but did not converge.
2	Preconditioner M was ill-conditioned.
3	<code>bicg</code> stagnated. (Two consecutive iterates were the same.)
4	One of the scalar quantities calculated during <code>bicg</code> became too small or too large to continue computing.

Whenever `flag` is not 0, the solution x returned is that with minimal norm residual computed over all the iterations. No messages are displayed if the `flag` output is specified.

`[x,flag,relres] = bicg(A,b,...)` also returns the relative residual norm $\|b - A \cdot x\| / \|b\|$. If `flag` is 0, `relres` \leq `tol`.

`[x,flag,relres,iter] = bicg(A,b,...)` also returns the iteration number at which x was computed, where $0 \leq \text{iter} \leq \text{maxit}$.

`[x,flag,relres,iter,resvec] = bicg(A,b,...)` also returns a vector of the residual norms at each iteration including $\|b - A \cdot x_0\|$.

Examples

Using `bicg` with a Matrix Input

This example shows how to use `bicg` with a matrix input. `bicg`. The following code:

```
n = 100;
on = ones(n,1);
```

```
A = spdiags([-2*on 4*on -on],-1:1,n,n);
b = sum(A,2);
tol = 1e-8;
maxit = 15;
M1 = spdiags([on/(-2) on],-1:0,n,n);
M2 = spdiags([4*on -on],0:1,n,n);

x = bicg(A,b,tol,maxit,M1,M2);
```

displays this message:

```
bicg converged at iteration 9 to a solution with relative
residual 5.3e-009
```

Using bicg with a Function Handle

This example replaces the matrix A in the previous example with a handle to a matrix-vector product function `afun`. The example is contained in a file `run_bicg` that

- Calls `bicg` with the `@afun` function handle as its first argument.
- Contains `afun` as a nested function, so that all variables in `run_bicg` are available to `afun`.

Place the following into a file called `run_bicg`:

```
function x1 = run_bicg
n = 100;
on = ones(n,1);
b = afun(on,'notransp');
tol = 1e-8;
maxit = 15;
M1 = spdiags([on/(-2) on],-1:0,n,n);
M2 = spdiags([4*on -on],0:1,n,n);
x1 = bicg(@afun,b,tol,maxit,M1,M2);

function y = afun(x,transp_flag)           % y = A'*x
    if strcmp(transp_flag,'transp')
        y = 4 * x;
```



```

        y(1:n-1) = y(1:n-1) - 2 * x(2:n);
        y(2:n) = y(2:n) - x(1:n-1);
    elseif strcmp(transp_flag,'notransp') % y = A*x
        y = 4 * x;
        y(2:n) = y(2:n) - 2 * x(1:n-1);
        y(1:n-1) = y(1:n-1) - x(2:n);
    end
end
end
end

```

When you enter

```
x1 = run_bicg;
```

MATLAB software displays the message

```

bicg converged at iteration 9 to a solution with ...
relative residual
5.3e-009

```

Using bicg with a Preconditioner

This example demonstrates the use of a preconditioner.

Load A = west0479, a real 479-by-479 nonsymmetric sparse matrix.

```
load west0479;
A = west0479;
```

Define b so that the true solution is a vector of all ones.

```
b = full(sum(A,2));
```

Set the tolerance and maximum number of iterations.

```
tol = 1e-12; maxit = 20;
```

Use bicg to find a solution at the requested tolerance and number of iterations.

```
[x0,f10,rr0,it0,rv0] = bicg(A,b,tol,maxit);
```

f10 is 1 because `bicg` does not converge to the requested tolerance $1e-12$ within the requested 20 iterations. In fact, the behavior of `bicg` is so poor that the initial guess (`x0 = zeros(size(A,2),1)`) is the best solution and is returned as indicated by `it0 = 0`. MATLAB® stores the residual history in `rv0`.

Plot the behavior of `bicg`.

```
semilogy(0:maxit,rv0/norm(b),'-o');  
xlabel('Iteration number');  
ylabel('Relative residual');
```

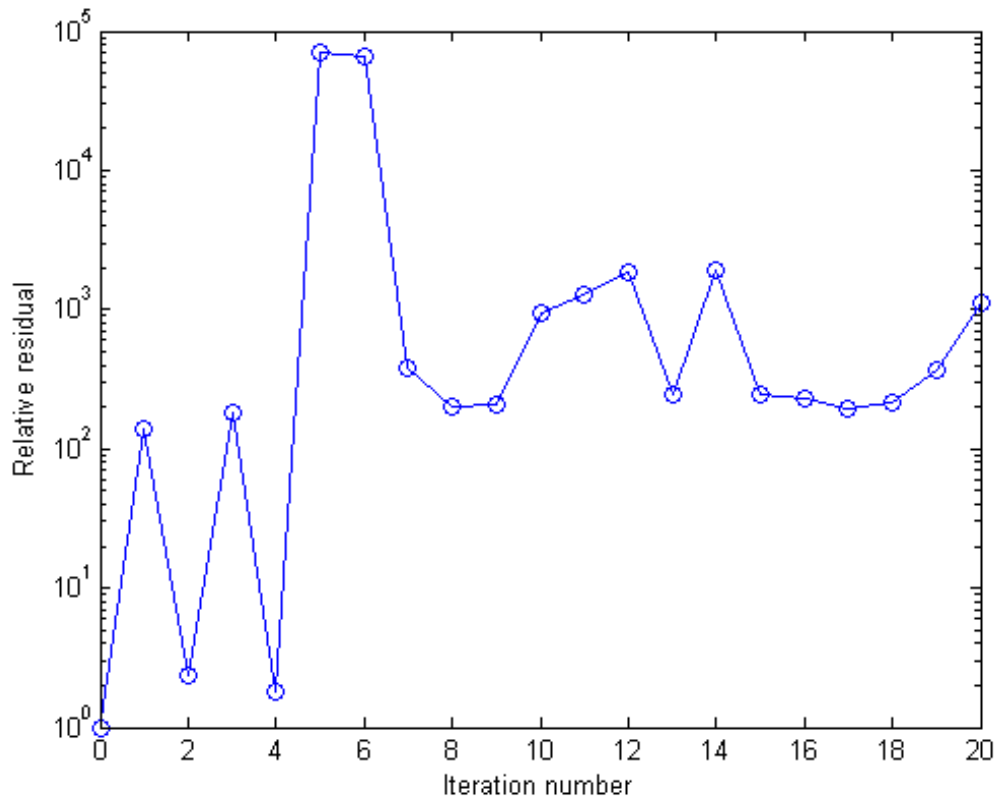

The plot shows that the solution does not converge. You can use a preconditioner to improve the outcome.

Create the preconditioner with `ilu`, since the matrix `A` is nonsymmetric.

```
[L,U] = ilu(A,struct('type','ilutp','droptol',1e-5));
```

Error using `ilu`

There is a pivot equal to zero. Consider decreasing the drop tolerance or consider using the `'udiag'` option.

MATLAB cannot construct the incomplete LU as it would result in a singular factor, which is useless as a preconditioner.

You can try again with a reduced drop tolerance, as indicated by the error message.

```
[L,U] = ilu(A,struct('type','ilutp','droptol',1e-6));  
[x1,f11,rr1,it1,rv1] = bicg(A,b,tol,maxit,L,U);
```

f11 is 0 because bicg drives the relative residual to $4.1410e-014$ (the value of rr1). The relative residual is less than the prescribed tolerance of $1e-12$ at the sixth iteration (the value of it1) when preconditioned by the incomplete LU factorization with a drop tolerance of $1e-6$. The output rv1(1) is norm(b), and the output rv1(7) is norm(b-A*x2).

You can follow the progress of bicg by plotting the relative residuals at each iteration starting from the initial estimate (iterate number 0).

```
semilogy(0:it1,rv1/norm(b),'-o');  
xlabel('Iteration number');  
ylabel('Relative residual');
```

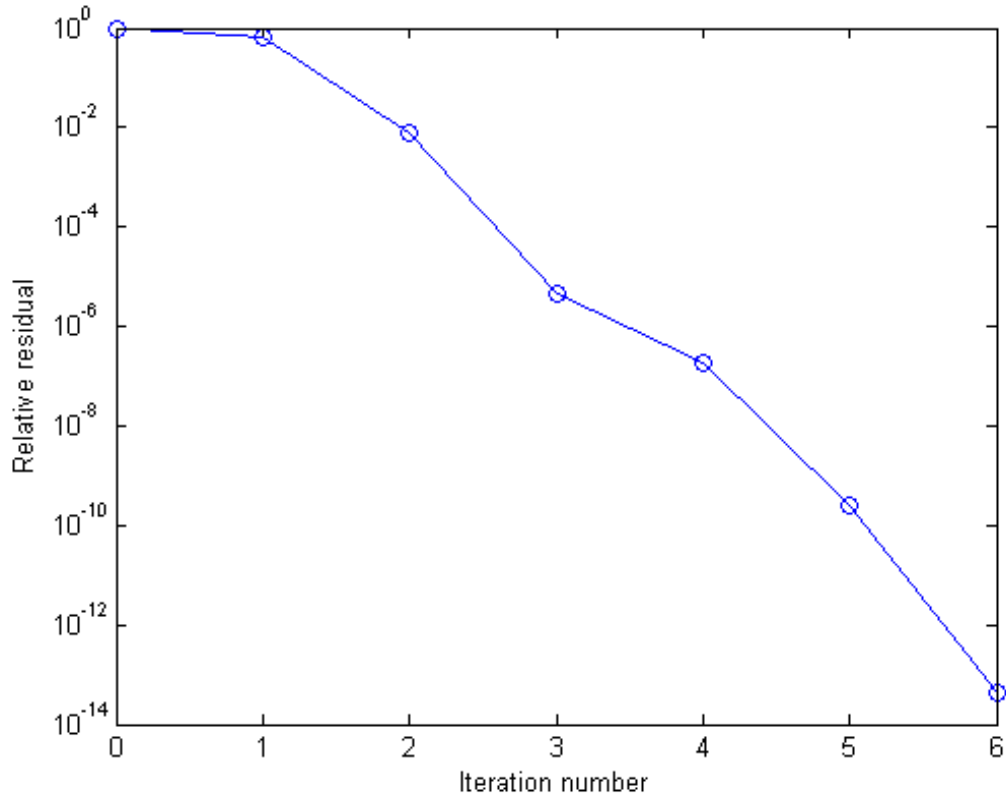

References

[1] Barrett, R., M. Berry, T.F. Chan, et al., *Templates for the Solution of Linear Systems: Building Blocks for Iterative Methods*, SIAM, Philadelphia, 1994.

See Also

`bicgstab` | `cgs` | `function_handle` | `gmres` | `ilu` | `lsqr` | `minres` | `pcg` | `qmr` | `symmlq` | `mldivide`

bicgstab

Purpose Biconjugate gradients stabilized method

Syntax

```
x = bicgstab(A,b)
bicgstab(A,b,tol)
bicgstab(A,b,tol,maxit)
bicgstab(A,b,tol,maxit,M)
bicgstab(A,b,tol,maxit,M1,M2)
bicgstab(A,b,tol,maxit,M1,M2,x0)
[x,flag] = bicgstab(A,b,...)
[x,flag,relres] = bicgstab(A,b,...)
[x,flag,relres,iter] = bicgstab(A,b,...)
[x,flag,relres,iter,resvec] = bicgstab(A,b,...)
```

Description `x = bicgstab(A,b)` attempts to solve the system of linear equations $A*x=b$ for x . The n -by- n coefficient matrix A must be square and should be large and sparse. The column vector b must have length n . A can be a function handle, `afun`, such that `afun(x)` returns $A*x$.

“Parameterizing Functions” explains how to provide additional parameters to the function `afun`, as well as the preconditioner function `mfun` described below, if necessary.

If `bicgstab` converges, a message to that effect is displayed. If `bicgstab` fails to converge after the maximum number of iterations or halts for any reason, a warning message is printed displaying the relative residual $\text{norm}(b-A*x)/\text{norm}(b)$ and the iteration number at which the method stopped or failed.

`bicgstab(A,b,tol)` specifies the tolerance of the method. If `tol` is `[]`, then `bicgstab` uses the default, $1e-6$.

`bicgstab(A,b,tol,maxit)` specifies the maximum number of iterations. If `maxit` is `[]`, then `bicgstab` uses the default, $\min(n,20)$.

`bicgstab(A,b,tol,maxit,M)` and `bicgstab(A,b,tol,maxit,M1,M2)` use preconditioner M or $M = M1*M2$ and effectively solve the system $\text{inv}(M)*A*x = \text{inv}(M)*b$ for x . If M is `[]` then `bicgstab` applies no preconditioner. M can be a function handle `mfun`, such that `mfun(x)` returns $M*x$.

`bicgstab(A,b,tol,maxit,M1,M2,x0)` specifies the initial guess. If `x0` is `[]`, then `bicgstab` uses the default, an all zero vector.

`[x,flag] = bicgstab(A,b,...)` also returns a convergence flag.

Flag	Convergence
0	<code>bicgstab</code> converged to the desired tolerance <code>tol</code> within <code>maxit</code> iterations.
1	<code>bicgstab</code> iterated <code>maxit</code> times but did not converge.
2	Preconditioner <code>M</code> was ill-conditioned.
3	<code>bicgstab</code> stagnated. (Two consecutive iterates were the same.)
4	One of the scalar quantities calculated during <code>bicgstab</code> became too small or too large to continue computing.

Whenever `flag` is not 0, the solution `x` returned is that with minimal norm residual computed over all the iterations. No messages are displayed if the `flag` output is specified.

`[x,flag,relres] = bicgstab(A,b,...)` also returns the relative residual $\text{norm}(b-A*x)/\text{norm}(b)$. If `flag` is 0, `relres` \leq `tol`.

`[x,flag,relres,iter] = bicgstab(A,b,...)` also returns the iteration number at which `x` was computed, where $0 \leq \text{iter} \leq \text{maxit}$. `iter` can be an integer + 0.5, indicating convergence halfway through an iteration.

`[x,flag,relres,iter,resvec] = bicgstab(A,b,...)` also returns a vector of the residual norms at each half iteration, including $\text{norm}(b-A*x0)$.

Examples

Using `bicgstab` with a Matrix Input

This example first solves $Ax = b$ by providing `A` and the preconditioner `M1` directly as arguments.

The code:

```
A = gallery('wilk',21);
b = sum(A,2);
tol = 1e-12;
maxit = 15;
M1 = diag([10:-1:1 1 1:10]);

x = bicgstab(A,b,tol,maxit,M1);
```

displays the message:

```
bicgstab converged at iteration 12.5 to a solution with relative
residual 2e-014.
```

Using bicgstab with a Function Handle

This example replaces the matrix *A* in the previous example with a handle to a matrix-vector product function *afun*, and the preconditioner *M1* with a handle to a backsolve function *mfun*. The example is contained in a file `run_bicgstab` that

- Calls `bicgstab` with the function handle `@afun` as its first argument.
- Contains `afun` and `mfun` as nested functions, so that all variables in `run_bicgstab` are available to `afun` and `mfun`.

The following shows the code for `run_bicgstab`:

```
function x1 = run_bicgstab
n = 21;
b = afun(ones(n,1));
tol = 1e-12;
maxit = 15;
x1 = bicgstab(@afun,b,tol,maxit,@mfun);

function y = afun(x)
    y = [0; x(1:n-1)] + ...
        [((n-1)/2:-1:0)'; (1:(n-1)/2)'].*x + ...
        [x(2:n); 0];
end
```



```
function y = mfun(r)
    y = r ./ [((n-1)/2:-1:1)'; 1; (1:(n-1)/2)'];
end
end
```

When you enter

```
x1 = run_bicgstab;
```

MATLAB software displays the message

```
bicgstab converged at iteration 12.5 to a solution with relative
residual 2e-014.
```

Using bicgstab with a Preconditioner

This example demonstrates the use of a preconditioner.

Load west0479, a real 479-by-479 nonsymmetric sparse matrix.

```
load west0479;
A = west0479;
```

Define b so that the true solution is a vector of all ones.

```
b = full(sum(A,2));
```

Set the tolerance and maximum number of iterations.

```
tol = 1e-12; maxit = 20;
```

Use bicgstab to find a solution at the requested tolerance and number of iterations.

```
[x0,f10,rr0,it0,rv0] = bicgstab(A,b,tol,maxit);
```

f10 is 1 because bicgstab does not converge to the requested tolerance 1e-12 within the requested 20 iterations. In fact, the behavior of bicgstab is so bad that the initial guess (x0 = zeros(size(A,2),1))

bicgstab

is the best solution and is returned as indicated by `it0 = 0`. MATLAB® stores the residual history in `rv0`.

Plot the behavior of `bicgstab`.

```
semilogy(0:0.5:maxit,rv0/norm(b),'-o');  
xlabel('Iteration number');  
ylabel('Relative residual');
```

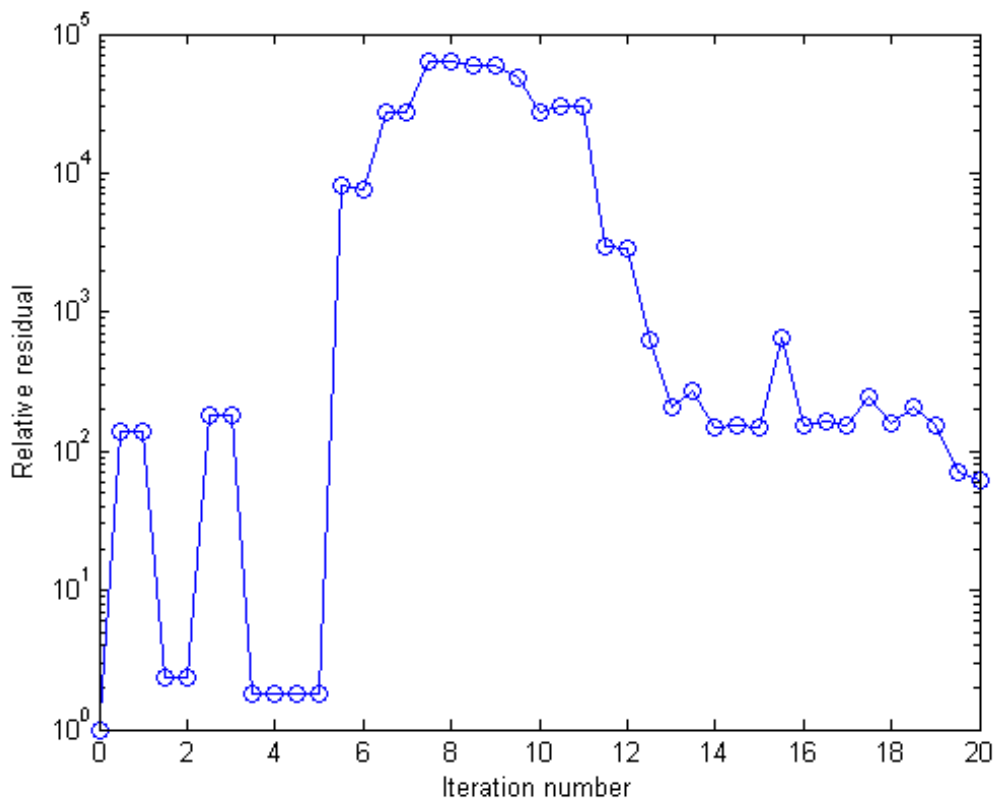

The plot shows that the solution does not converge. You can use a preconditioner to improve the outcome.

Create a preconditioner with `ilu`, since `A` is nonsymmetric.

```
[L,U] = ilu(A,struct('type','ilutp','droptol',1e-5));
```

Error using `ilu`

There is a pivot equal to zero. Consider decreasing the drop tolerance or consider using the `'udiag'` option.

MATLAB cannot construct the incomplete LU as it would result in a singular factor, which is useless as a preconditioner.

You can try again with a reduced drop tolerance, as indicated by the error message.

```
[L,U] = ilu(A,struct('type','ilutp','droptol',1e-6));  
[x1,f11,rr1,it1,rv1] = bicgstab(A,b,tol,maxit,L,U);
```

`f11` is 0 because `bicgstab` drives the relative residual to $5.9829e-014$ (the value of `rr1`). The relative residual is less than the prescribed tolerance of $1e-12$ at the third iteration (the value of `it1`) when preconditioned by the incomplete LU factorization with a drop tolerance of $1e-6$. The output `rv1(1)` is `norm(b)` and the output `rv1(7)` is `norm(b-A*x2)` since `bicgstab` uses half iterations.

You can follow the progress of `bicgstab` by plotting the relative residuals at each iteration starting from the initial estimate (iterate number 0).

```
semilogy(0:0.5:it1,rv1/norm(b),'-o');  
xlabel('Iteration Number');  
ylabel('Relative Residual');
```

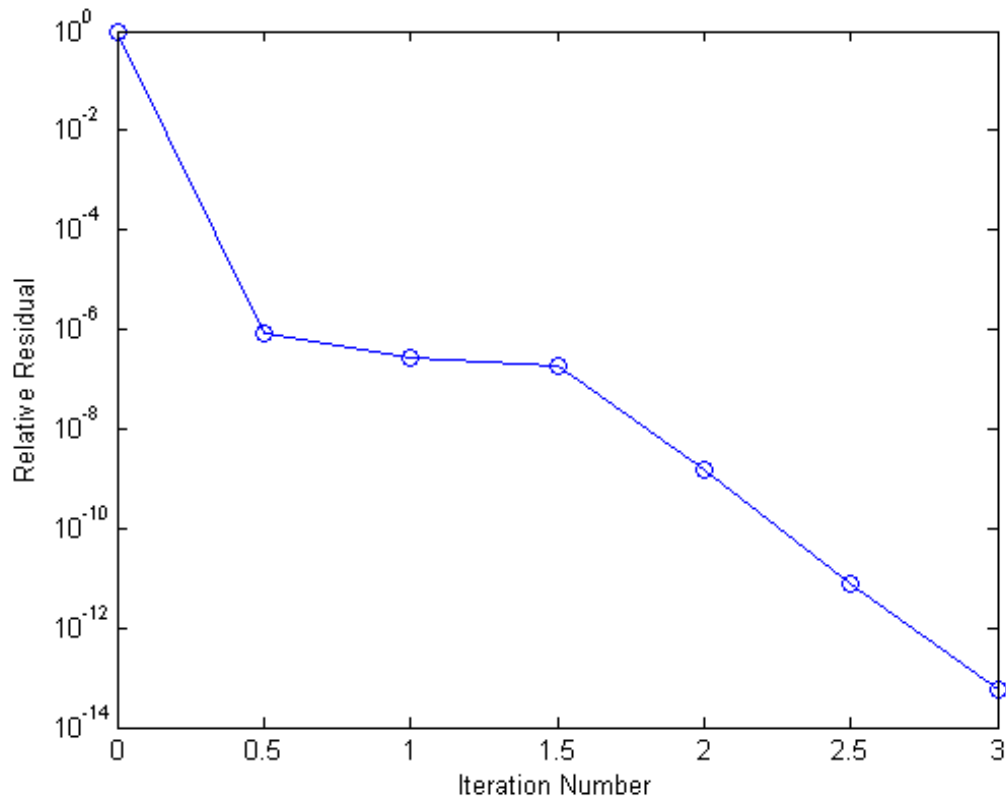

References

[1] Barrett, R., M. Berry, T.F. Chan, et al., *Templates for the Solution of Linear Systems: Building Blocks for Iterative Methods*, SIAM, Philadelphia, 1994.

[2] van der Vorst, H.A., "BI-CGSTAB: A fast and smoothly converging variant of BI-CG for the solution of nonsymmetric linear systems," *SIAM J. Sci. Stat. Comput.*, March 1992, Vol. 13, No. 2, pp. 631–644.

See Also

`bicg` | `cgs` | `function_handle` | `gmres` | `lsqr` | `ilu` | `minres` | `pcg` | `qmr` | `symmlq` | `mldivide`

bicgstabl

Purpose Biconjugate gradients stabilized (l) method

Syntax

```
x = bicgstabl(A,b)
x = bicgstabl(afun,b)
x = bicgstabl(A,b,tol)
x = bicgstabl(A,b,tol,maxit)
x = bicgstabl(A,b,tol,maxit,M)
x = bicgstabl(A,b,tol,maxit,M1,M2)
x = bicgstabl(A,b,tol,maxit,M1,M2,x0)
[x,flag] = bicgstabl(A,b,...)
[x,flag,relres] = bicgstabl(A,b,...)
[x,flag,relres,iter] = bicgstabl(A,b,...)
[x,flag,relres,iter,resvec] = bicgstabl(A,b,...)
```

Description

`x = bicgstabl(A,b)` attempts to solve the system of linear equations $A*x=b$ for x . The n -by- n coefficient matrix A must be square and the right-hand side column vector b must have length n .

`x = bicgstabl(afun,b)` accepts a function handle `afun` instead of the matrix A . `afun(x)` accepts a vector input x and returns the matrix-vector product $A*x$. In all of the following syntaxes, you can replace A by `afun`.

`x = bicgstabl(A,b,tol)` specifies the tolerance of the method. If `tol` is `[]` then `bicgstabl` uses the default, $1e-6$.

`x = bicgstabl(A,b,tol,maxit)` specifies the maximum number of iterations. If `maxit` is `[]` then `bicgstabl` uses the default, $\min(N,20)$.

`x = bicgstabl(A,b,tol,maxit,M)` and `x = bicgstabl(A,b,tol,maxit,M1,M2)` use preconditioner M or $M=M1*M2$ and effectively solve the system $A*inv(M)*x = b$ for x . If M is `[]` then a preconditioner is not applied. M may be a function handle returning $M\backslash x$.

`x = bicgstabl(A,b,tol,maxit,M1,M2,x0)` specifies the initial guess. If `x0` is `[]` then `bicgstabl` uses the default, an all zero vector.

`[x,flag] = bicgstabl(A,b,...)` also returns a convergence flag:

Flag	Convergence
0	bicgstabl converged to the desired tolerance <code>tol</code> within <code>maxit</code> iterations.
1	bicgstabl iterated <code>maxit</code> times but did not converge.
2	Preconditioner <code>M</code> was ill-conditioned.
3	bicgstabl stagnated. (Two consecutive iterates were the same.)
4	One of the scalar quantities calculated during bicgstabl became too small or too large to continue computing.

`[x,flag,relres] = bicgstabl(A,b,...)` also returns the relative residual $\text{norm}(b-A*x)/\text{norm}(b)$. If `flag` is 0, $\text{relres} \leq \text{tol}$.

`[x,flag,relres,iter] = bicgstabl(A,b,...)` also returns the iteration number at which `x` was computed, where $0 \leq \text{iter} \leq \text{maxit}$. `iter` can be `k/4` where `k` is some integer, indicating convergence at a given quarter iteration.

`[x,flag,relres,iter,resvec] = bicgstabl(A,b,...)` also returns a vector of the residual norms at each quarter iteration, including $\text{norm}(b-A*x_0)$.

Examples

Using bicgstabl with Inputs or with a Function

You can pass inputs directly to `bicgstabl`:

```
n = 21;
A = gallery('wilk',n);
b = sum(A,2);
tol = 1e-12;
maxit = 15;
M = diag([10:-1:1 1 1:10]);
x = bicgstabl(A,b,tol,maxit,M);
```

You can also use a matrix-vector product function:

```
function y = afun(x,n)
y = [0; x(1:n-1)] + [((n-1)/2:-1:0)';
(1:(n-1)/2)'] .* x + [x(2:n); 0];
```

and a preconditioner backsolve function:

```
function y = mfun(r,n)
y = r ./ [((n-1)/2:-1:1)';
1;
(1:(n-1)/2)'];
```

as inputs to `bicgstabl`:

```
x1 = bicgstabl(@(x)afun(x,n),b,tol,maxit,@(x)mfun(x,n));
```

Using bicgstabl with a Preconditioner

This example demonstrates the use of a preconditioner.

Load `west0479`, a real 479-by-479 nonsymmetric sparse matrix.

```
load west0479;
A = west0479;
```

Define `b` so that the true solution is a vector of all ones.

```
b = full(sum(A,2));
```

Set the tolerance and maximum number of iterations.

```
tol = 1e-12; maxit = 20;
```

Use `bicgstabl` to find a solution at the requested tolerance and number of iterations.

```
[x0,f10,rr0,it0,rv0] = bicgstabl(A,b,tol,maxit);
```

`f10` is 1 because `bicgstabl` does not converge to the requested tolerance $1e-12$ within the requested 20 iterations. In fact, the behavior of `bicgstabl` is so poor that the initial guess (`x0 = zeros(size(A,2),1)`)

is the best solution and is returned as indicated by `it0 = 0`. MATLAB® stores the residual history in `rv0`.

Plot the behavior of `bicgstabl`.

```
semilogy(0:0.25:maxit,rv0/norm(b),'-o');  
xlabel('Iteration number');  
ylabel('Relative residual');
```

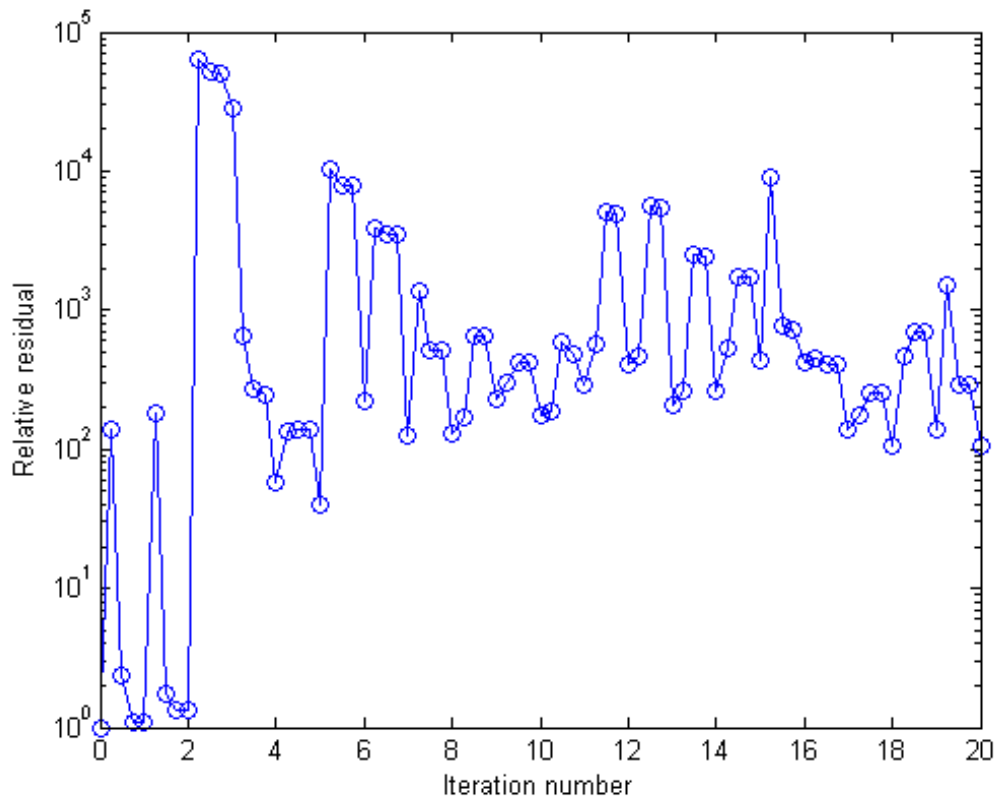

The plot shows that the solution does not converge. You can use a preconditioner to improve the outcome.

Create a preconditioner with `ilu`, since `A` is nonsymmetric.

```
[L,U] = ilu(A,struct('type','ilutp','droptol',1e-5));
```

Error using `ilu`

There is a pivot equal to zero. Consider decreasing the drop tolerance or consider using the `'udiag'` option.

MATLAB cannot construct the incomplete LU as it would result in a singular factor, which is useless as a preconditioner.

You can try again with a reduced drop tolerance, as indicated by the error message.

```
[L,U] = ilu(A,struct('type','ilutp','droptol',1e-6));  
[x1,f11,rr1,it1,rv1] = bicgstabl(A,b,tol,maxit,L,U);
```

`f11` is 0 because `bicgstabl` drives the relative residual to $1.0257e-015$ (the value of `rr1`). The relative residual is less than the prescribed tolerance of $1e-12$ at the sixth iteration (the value of `it1`) when preconditioned by the incomplete LU factorization with a drop tolerance of $1e-6$. The output `rv1(1)` is `norm(b)`, and the output `rv1(9)` is `norm(b-A*x2)` since `bicgstabl` uses quarter iterations.

You can follow the progress of `bicgstabl` by plotting the relative residuals at each iteration starting from the initial estimate (iterate number 0).

```
semilogy(0:0.25:it1,rv1/norm(b),'-o');  
set(gca,'XTick',0:0.25:it1);  
xlabel('Iteration number');  
ylabel('Relative residual');
```

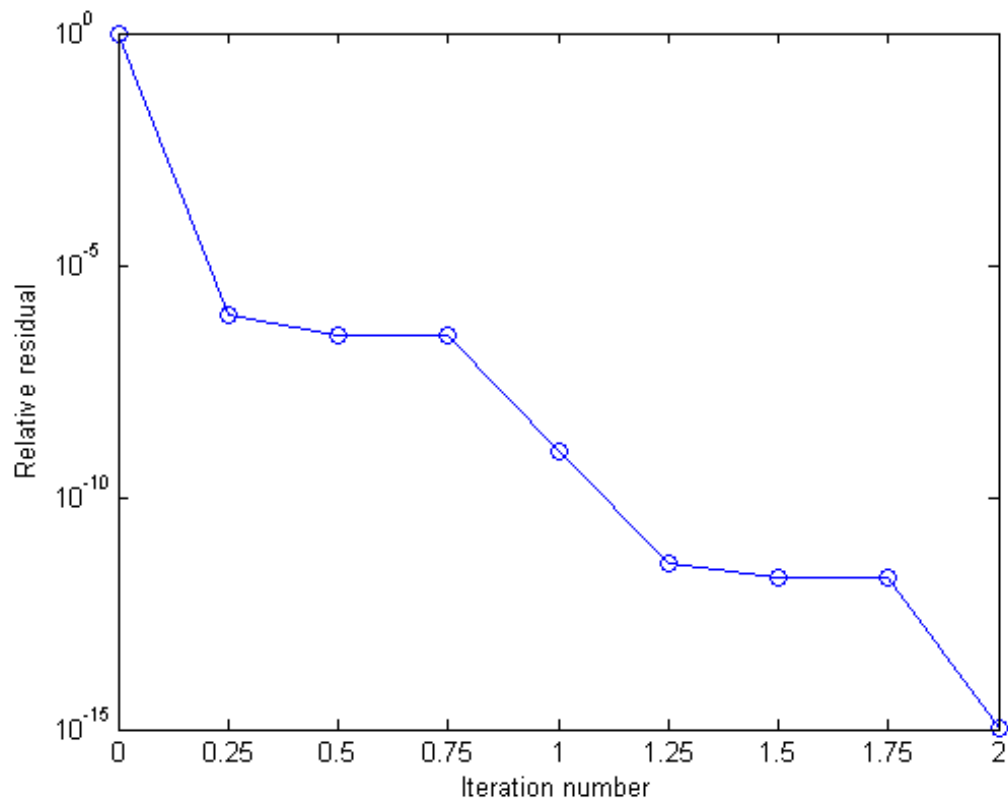
**See Also**

[bicg](#) | [bicgstab](#) | [cgs](#) | [function_handle](#) | [gmres](#) | [lsqr](#) | [ilu](#) | [minres](#) | [pcg](#) | [qmr](#) | [symmlq](#) | [mldivide](#)

bin2dec

Purpose Convert binary number string to decimal number

Syntax `bin2dec(binarystr)`

Description `bin2dec(binarystr)` interprets the binary string *binarystr* and returns the equivalent decimal number.

`bin2dec` ignores any space (' ') characters in the input string.

Examples Binary 010111 converts to decimal 23:

```
bin2dec('010111')
ans =
    23
```

Because space characters are ignored, this string yields the same result:

```
bin2dec(' 010 111 ')
ans =
    23
```

See Also `dec2bin`

Purpose Set FTP transfer type to binary

Syntax `binary(ftpobj)`

Description `binary(ftpobj)` sets the FTP download and upload mode to binary, which does not convert new line characters. Binary mode is the default for FTP objects. If you previously called the `ascii` method, use this method before transferring a nontext file, such as an executable or ZIP archive.

Input Arguments **ftpobj**
FTP object created by `ftp`.

Examples Connect to the MathWorks FTP server, and set the transfer mode to binary:

```
mw=ftp('ftp.mathworks.com');  
binary(mw)
```

See Also `ascii` | `ftp`

bitand

Purpose

Bit-wise AND

Syntax

```
intout = bitand(integ1,integ2)
intout = bitand(integ1,integ2,assumedtype)

objout = bitand(netobj1,netobj2)
```

Description

`intout = bitand(integ1,integ2)` returns the bit-wise AND of values `integ1` and `integ2`.

`intout = bitand(integ1,integ2,assumedtype)` assumes that `integ1` and `integ2` are of `assumedtype`.

`objout = bitand(netobj1,netobj2)` returns the bit-wise AND of the .NET enumeration objects `netobj1` and `netobj2`.

Input Arguments

integ1, integ2 - Input values

signed integer arrays | unsigned integer arrays | double arrays

Input values, specified as signed integer arrays, unsigned integer arrays, or double arrays. `integ1` and `integ2` must be the same data type, or one must be a scalar double value.

- If `integ1` and `integ2` are double arrays, and `assumedtype` is not specified, then MATLAB treats `integ1` and `integ2` as unsigned 64-bit integers.
- If `assumedtype` is specified, then all elements in `integ1` and `integ2` must have integer values within the range of `assumedtype`.

Data Types

double | int8 | int16 | int32 | int64 | uint8 | uint16 |
uint32 | uint64

assumedtype - Assumed data type of integ1 and integ2

'uint64' | 'uint32' | 'uint16' | 'uint8' | 'int64' | 'int32' |
'int16' | 'int8'

Assumed data type of `integ1` and `integ2`, specified as `'uint64'`, `'uint32'`, `'uint16'`, `'uint8'`, `'int64'`, `'int32'`, `'int16'`, or `'int8'`.

- If `integ1` and `integ2` are double arrays, then `assumedtype` can specify any valid integer type, but defaults to `'uint64'`.
- If `integ1` and `integ2` are integer type arrays, then `assumedtype` must specify that same integer type.

Data Types

`char`

`netobj1`, `netobj2` - Input values

`.NET` enumeration objects

Input values, specified as `.NET` enumeration objects. You must be running a version of Windows to use `.NET` enumeration objects as input arguments.

`bitand` is an instance method for MATLAB enumeration objects created from a `.NET` enumeration.

Output Arguments

`intout` - Bit-wise AND result

signed integer array | unsigned integer array | double array

Bit-wise AND result, returned as a signed integer array, unsigned integer array, or double array. `intout` is the same data type and size as `integ1` and `integ2`.

- If either `integ1` or `integ2` is a scalar double, and the other is a non-double integer type, `intout` is the non-double integer type.

`objout` - Bit-wise AND result

`.NET` enumeration object

Bit-wise AND result, returned as a `.NET` enumeration objects.

Examples

Truth Table

Create a truth table for the logical AND operation.

bitand

```
A = uint8([0 1; 0 1]);
B = uint8([0 0; 1 1]);
TTable = bitand(A, B)
```

```
TTable =
```

```
    0    0
    0    1
```

bitand returns 1 only if both bit-wise inputs are 1.

Negative Values

Explore how bitand handles negative values

MATLAB encodes signed integers using two's complement. Thus, the bit-wise AND of 5 (11111010) and 6 (00000110) is 2 (00000010).

```
C = -5;
D = 6;
bitand(C,D,'int8')
```

```
ans =
```

```
    2
```

See Also

[bitcmp](#) | [bitget](#) | [bitor](#) | [bitnot](#) | [bitshift](#) | [bitset](#) | [bitxor](#) | [intmax](#)

Related Examples

- “Creating .NET Enumeration Bit Flags”

Purpose	Bit-wise complement
Compatibility	bitcmp(A,N) will not accept N in a future release. Use bitcmp(A) or bitcmp(A,assumedtype) instead.
Syntax	<pre>cmp = bitcmp(A) cmp = bitcmp(A,assumedtype) cmp = bitcmp(A,N)</pre>
Description	<p>cmp = bitcmp(A) returns the bit-wise complement of A.</p> <p>cmp = bitcmp(A,assumedtype) assumes that A is of assumedtype.</p> <p>cmp = bitcmp(A,N) returns an N-bit complement of A. Elements of A cannot exceed 2^N-1.</p>
Input Arguments	<p>A - Input value signed integer array unsigned integer array double array</p> <p>Input value, specified as a signed integer array, unsigned integer array, or double array.</p> <ul style="list-style-type: none">• If A is a double array, and assumedtype is not specified, then MATLAB treats A as an unsigned 64-bit integer.• If assumedtype is specified, then all elements in A must have integer values within the range of assumedtype. <p>Data Types double int8 int16 int32 int64 uint8 uint16 uint32 uint64</p> <p>assumedtype - Assumed data type of A 'uint64' 'uint32' 'uint16' 'uint8' 'int64' 'int32' 'int16' 'int8'</p>

bitcmp

Assumed data type of A, specified as 'uint64', 'uint32', 'uint16', 'uint8', 'int64', 'int32', 'int16', or 'int8'.

- If A is a double array, then `assumedtype` can specify any valid integer type, but defaults to 'uint64'.
- If A is an integer type array, then `assumedtype` must specify that same integer type.

Data Types

char

N - number of returned bits

integer

Number of returned bits, specified as an integer. N cannot exceed the number of bits in the integer type of A.

Data Types

double | int8 | int16 | int32 | int64 | uint8 | uint16 |
uint32 | uint64

Output Arguments

cmp - Bit-wise complement

signed integer array | unsigned integer array | double array

Bit-wise complement, returned as a signed integer array, unsigned integer array, or double array. `cmp` is the same size and type as A.

Examples

Complement of a Negative Integer

```
A = int8(-11);  
cmp = bitcmp(A)
```

```
cmp =
```

```
    10
```

You can see the complement operation when the numbers are shown in binary.

```
original = bitget(A,8:-1:1)
complement = bitget(bitcmp(A),8:-1:1)

original =

     1     1     1     1     0     1     0     1

complement =

     0     0     0     0     1     0     1     0
```

Complement of Unsigned Integers

```
cmp = bitcmp(64,'uint8')
maxint = intmax('uint8') - 64

cmp =

    191

maxint =

    191
```

The complement of an unsigned integer is equal to itself subtracted from the maximum integer of its data type.

See Also

[bitand](#) | [bitget](#) | [bitor](#) | [bitshift](#) | [bitset](#) | [bitxor](#) | [intmax](#)

bitget

Purpose

Get bit at specified position

Syntax

```
b = bitget(A,bit)
b = bitget(A,bit,assumedtype)
```

Description

`b = bitget(A,bit)` returns the bit value at position `bit` in integer array `A`.

`b = bitget(A,bit,assumedtype)` assumes that `A` is of `assumedtype`.

Input Arguments

A - Input value

signed integer array | unsigned integer array | double array

Input value, specified as a signed integer array, unsigned integer array, or double array.

- If `A` is a double array, and `assumedtype` is not specified, then MATLAB treats `A` as an unsigned 64-bit integer.
- If `assumedtype` is specified, then all elements in `A` must have integer values within the range of `assumedtype`.

Data Types

double | int8 | int16 | int32 | int64 | uint8 | uint16 | uint32 | uint64

bit - Bit position

integer | integer array

Bit position, specified as an integer or integer array. `bit` must be between 1 (the least-significant bit) and the number of bits in the integer class of `A`.

Data Types

double | int8 | int16 | int32 | int64 | uint8 | uint16 | uint32 | uint64

assumedtype - Assumed data type of A

```
'uint64' | 'uint32' | 'uint16' | 'uint8' | 'int64' | 'int32' |
'int16' | 'int8'
```

Assumed data type of A, specified as 'uint64', 'uint32', 'uint16', 'uint8', 'int64', 'int32', 'int16', or 'int8'.

- If A is a double array, then `assumedtype` can specify any valid integer type, but defaults to 'uint64'.
- If A is an integer type array, then `assumedtype` must specify that same integer type.

Data Types

char

Output Arguments

b - Bit value at bit

0 | 1

Bit value at `bit`, returned as 0 or 1. `b` is the same data type as A.

Examples

Maximum Integer

Find the difference in the binary representation between the maximum integer of signed and unsigned integers.

```
a1 = intmax('int8');
a2 = intmax('uint8');
b1 = bitget(a1,8:-1:1)
b2 = bitget(a2,8:-1:1)
```

b1 =

```
0  1  1  1  1  1  1  1
```

b2 =

```
1  1  1  1  1  1  1  1
```

The signed integers require a bit to accommodate negative integers.

Negative Numbers Using Two's Complement

Find the 8-bit representation of a negative number.

```
A = -29;  
b = bitget(A,8:-1:1,'int8')
```

b =

```
1 1 1 0 0 0 1 1
```

See Also

[bitand](#) | [bitcmp](#) | [bitor](#) | [bitshift](#) | [bitset](#) | [bitxor](#) | [intmax](#)

Purpose	Maximum double-precision floating-point integer
Compatibility	bitmax will be removed in a future release. Use <code>flintmax</code> instead.
Syntax	<code>bitmax</code>
Description	<code>bitmax</code> returns the maximum unsigned double-precision floating-point integer for your computer. It is the value when all bits are set, namely the value $2^{53} - 1$.

Note Instead of integer-valued double-precision variables, use unsigned integers for bit manipulations and replace `bitmax` with `intmax`.

Examples Display in different formats the largest floating point integer and the largest 32 bit unsigned integer:

```
format long e
bitmax
ans =
    9.007199254740991e+015
```

```
intmax('uint32')
ans =
    4294967295
```

```
format hex
bitmax
ans =
    433fffffffffffffff
```

```
intmax('uint32')
ans =
    ffffffff
```

bitmax

In the second bitmax statement, the last 13 hex digits of bitmax are f, corresponding to 52 1's (all 1's) in the mantissa of the binary representation. The first 3 hex digits correspond to the sign bit 0 and the 11 bit biased exponent 10000110011 in binary (1075 in decimal), and the actual exponent is $(1075 - 1023) = 52$. Thus the binary value of bitmax is $1.111\dots111 \times 2^{52}$ with 52 trailing 1's, or $2^{53} - 1$.

See Also

bitand | bitcmp | bitget | bitor | bitset | bitshift | bitxor

Purpose	.NET enumeration object bit-wise NOT instance method
Syntax	<code>objout = bitnot(netobj)</code>
Description	<code>objout = bitnot(netobj)</code> reverses all bits of the .NET enumeration objects <code>netobj</code> .
Input Arguments	netobj - Input value .NET enumeration objects Input value, specified as .NET enumeration object. You must be running a version of Windows to use .NET enumeration objects as input arguments.
Output Arguments	objout - Bit-wise NOT result .NET enumeration object Bit-wise NOT result, returned as a .NET enumeration object.
Limitations	<ul style="list-style-type: none">• The method is an instance method for MATLAB enumeration objects created from a .NET enumeration. This method does not have an equivalent MATLAB function.
See Also	<code>bitand</code> <code>bitor</code> <code>bitxor</code>
Related Examples	<ul style="list-style-type: none">• “Creating .NET Enumeration Bit Flags”

bitor

Purpose Bit-wise OR

Syntax

```
intout = bitor(integ1,integ2)
intout = bitor(integ1,integ2,assumedtype)

objout = bitor(netobj1,netobj2)
```

Description

`intout = bitor(integ1,integ2)` returns the bit-wise OR of `integ1` and `integ2`.

`intout = bitor(integ1,integ2,assumedtype)` assumes that `integ1` and `integ2` are of `assumedtype`.

`objout = bitor(netobj1,netobj2)` returns the bit-wise OR of the .NET enumeration objects `netobj1` and `netobj2`.

Input Arguments

integ1, integ2 - Input values

signed integer arrays | unsigned integer arrays | double arrays

Input values, specified as signed integer arrays, unsigned integer arrays, or double arrays. `integ1` and `integ2` must be the same data type, or one must be a scalar double value.

- If `integ1` and `integ2` are double arrays, and `assumedtype` is not specified, then MATLAB treats `integ1` and `integ2` as unsigned 64-bit integers.
- If `assumedtype` is specified, then all elements in `integ1` and `integ2` must have integer values within the range of `assumedtype`.

Data Types

double | int8 | int16 | int32 | int64 | uint8 | uint16 | uint32 | uint64

assumedtype - Assumed data type of integ1 and integ2

'uint64' | 'uint32' | 'uint16' | 'uint8' | 'int64' | 'int32' | 'int16' | 'int8'

Assumed data type of `integ1` and `integ2`, specified as `'uint64'`, `'uint32'`, `'uint16'`, `'uint8'`, `'int64'`, `'int32'`, `'int16'`, or `'int8'`.

- If `integ1` and `integ2` are double arrays, then `assumedtype` can specify any valid integer type, but defaults to `'uint64'`.
- If `integ1` and `integ2` are integer type arrays, then `assumedtype` must specify that same integer type.

Data Types

`char`

`netobj1`, `netobj2` - Input values

.NET enumeration objects

Input values, specified as .NET enumeration objects. You must be running a version of Windows to use .NET enumeration objects as input arguments.

`bitor` is an instance method for MATLAB enumeration objects created from a .NET enumeration.

Output Arguments

`intout` - Bit-wise OR result

signed integer array | unsigned integer array | double array

Bit-wise OR result, returned as a signed integer array, unsigned integer array, or double array. `intout` is the same data type and size as `integ1` and `integ2`.

- If either `integ1` or `integ2` is a scalar double, and the other is a non-double integer type, `intout` is the non-double integer type.

`objout` - Bit-wise OR result

.NET enumeration object

Bit-wise OR result, returned as a .NET enumeration objects.

Examples

Truth Table

Create a truth table for the logical OR operation.

bitor

```
A = uint8([0 1; 0 1]);  
B = uint8([0 0; 1 1]);  
TTable = bitor(A, B)
```

```
TTable =
```

```
    0    1  
    1    1
```

bitor returns 1 if either bit-wise input is 1.

Negative Values

Explore how bitor handles negative values.

MATLAB encodes negative integers using two's complement. Thus, the bit-wise OR of -5 (11111010) and 6 (00000110) is -1 (11111110).

```
C = -5;  
D = 6;  
bitor(C,D,'int8')
```

```
ans =
```

```
-1
```

See Also

[bitand](#) | [bitnot](#) | [bitcmp](#) | [bitget](#) | [bitshift](#) | [bitset](#) | [bitxor](#) | [intmax](#)

Related Examples

- “Creating .NET Enumeration Bit Flags”

Purpose	Set bit at specific location
Syntax	<pre>intout = bitset(A,bit) intout = bitset(A,bit,assumedtype) intout = bitset(A,bit,V) intout = bitset(A,bit,V,assumedtype)</pre>
Description	<p><code>intout = bitset(A,bit)</code> returns the value of <code>A</code> with position <code>bit</code> set to 1 (on).</p> <p><code>intout = bitset(A,bit,assumedtype)</code> assumes <code>A</code> is of type <code>assumedtype</code>.</p> <p><code>intout = bitset(A,bit,V)</code> returns <code>A</code> with position <code>bit</code> set to the value of <code>V</code>.</p> <ul style="list-style-type: none">• If <code>V</code> is zero, then the bit position <code>bit</code> is set to 0 (off).• If <code>V</code> is nonzero, then the bit position <code>bit</code> is set to 1 (on). <p><code>intout = bitset(A,bit,V,assumedtype)</code> assumes <code>A</code> is of type <code>assumedtype</code>.</p>
Input Arguments	<p>A - Input value signed integer array unsigned integer array double array</p> <p>Input value, specified as a signed integer array, unsigned integer array, or double array.</p> <ul style="list-style-type: none">• If <code>A</code> is a double array, and <code>assumedtype</code> is not specified, then MATLAB treats <code>A</code> as an unsigned 64-bit integer.• If <code>assumedtype</code> is specified, then all elements in <code>A</code> must have integer values within the range of <code>assumedtype</code>.

Data Types

double | int8 | int16 | int32 | int64 | uint8 | uint16 |
uint32 | uint64

bit - Bit position

integer | integer array

Bit position, specified as an integer or integer array. `bit` must be between 1 (the least significant bit) and the number of bits in the integer class of `A`.

Data Types

double | int8 | int16 | int32 | int64 | uint8 | uint16 |
uint32 | uint64

assumedtype - Assumed data type of A

'uint64' | 'uint32' | 'uint16' | 'uint8' | 'int64' | 'int32' |
'int16' | 'int8'

Assumed data type of `A`, specified as 'uint64', 'uint32', 'uint16', 'uint8', 'int64', 'int32', 'int16', or 'int8'.

- If `A` is a double array, then `assumedtype` can specify any valid integer type, but defaults to 'uint64'.
- If `A` is an integer type array, then `assumedtype` must specify that same integer type.

Data Types

char

V - bit value

scalar | numeric array

Bit value, specified as a scalar or a numeric array. If `V` and `bit` are arrays, they must be the same size.

Data Types

double | int8 | int16 | int32 | int64 | uint8 | uint16 |
uint32 | uint64 | logical

Output Arguments

intout - Adjusted integer

signed integer array | unsigned integer array | double array

Adjusted integer, returned as a signed integer array, unsigned integer array, or double array. `intout` is the same size and type as `A`.

Examples

Set Bits to On

Add powers of 2 onto a number.

```
A = 4;  
intout = bitset(A,4:6)
```

```
intout =  
  
      12      20      36
```

You can see that `bitset` sequentially turns on bits 4 through 6.

```
c = dec2bin(intout)
```

```
c =  
  
001100  
010100  
100100
```

Out of Range of Integer Type

MATLAB throws an error if you specify an integer outside the range of `assumedtype`.

```
intout = bitset(300,5,'int8')
```

```
Error using bitset  
Double inputs must have integer values in the range of ASSUMEDTYPE.
```

You can avoid this error by limiting your input to the range of the specified datatype.

Set Bits to Off

Repeatedly subtract powers of 2 from a number.

```
a = intmax('uint8')
for k = 0:7
    a = bitset(a, 8-k, 0);
    b(1,k+1) = a;
end
b
```

a =

255

b =

127 63 31 15 7 3 1 0

Set Multiple Bits

Set multiple bits to different values

```
bits = 2:6;
val = [1 0 0 1 1];
intout = bitset(0,bits,val,'int8')
```

intout =

2 0 0 16 32

See Also

[bitand](#) | [bitcmp](#) | [bitget](#) | [bitor](#) | [bitshift](#) | [bitxor](#) | [intmax](#)

Purpose	Shift bits specified number of places
Compatibility	<p><code>bitshift(A,k,N)</code> will not accept the argument <code>N</code> in a future release. Use <code>bitshift(A,k)</code> or <code>bitcmp(A,k,assumedtype)</code> instead.</p> <p><code>bitshift</code> no longer interprets double values as 53-bit unsigned integers by default, but as <code>uint64</code> values.</p>
Syntax	<pre>intout = bitshift(A,k) intout = bitshift(A,k,assumedtype) intout = bitshift(A,k,N)</pre>
Description	<p><code>intout = bitshift(A,k)</code> returns <code>A</code> shifted to the left by <code>k</code> bits, equivalent to multiplying by 2^k. Negative values of <code>k</code> correspond to shifting bits right or dividing by $2^{ k }$ and rounding to the nearest integer towards negative infinite. Any overflow bits are truncated.</p> <ul style="list-style-type: none">• If <code>A</code> is an array of signed integers, then <code>bitshift</code> returns the arithmetic shift results, preserving the signed bit when <code>k</code> is negative, and not preserving the signed bit when <code>k</code> is positive.• If <code>k</code> is positive, MATLAB shifts the bits to the left and inserts <code>k</code> 0-bits on the right.• If <code>k</code> is negative and <code>A</code> is nonnegative, then MATLAB shifts the bits to the right and inserts <code> k </code> 0-bits on the left.• If <code>k</code> is negative and <code>A</code> is negative, then MATLAB shifts the bits to the right and inserts <code> k </code> 1-bits on the left. <p><code>intout = bitshift(A,k,assumedtype)</code> assumes <code>A</code> is of type <code>assumedtype</code>.</p> <p><code>intout = bitshift(A,k,N)</code> truncates any bits that overflow <code>N</code> bits.</p>

bitshift

Input Arguments

A - Input value

signed integer array | unsigned integer array | double array

Input value, specified as a signed integer array, unsigned integer array, or double array.

- If A is a double array, and `assumedtype` is not specified, then MATLAB treats A as an unsigned 64-bit integer.
- If `assumedtype` is specified, then all elements in A must have integer values within the range of `assumedtype`.

Data Types

double | int8 | int16 | int32 | int64 | uint8 | uint16 | uint32 | uint64

k - Number of switched bits

integer | integer array

Number of switched bits, specified as an integer or integer array.

Data Types

double | int8 | int16 | int32 | int64 | uint8 | uint16 | uint32 | uint64

assumedtype - Assumed data type of A

'uint64' | 'uint32' | 'uint16' | 'uint8' | 'int64' | 'int32' | 'int16' | 'int8'

Assumed data type of A, specified as 'uint64', 'uint32', 'uint16', 'uint8', 'int64', 'int32', 'int16', or 'int8'.

- If A is an integer type array, then `assumedtype` must specify that same integer type.
- If A is a double array, then `assumedtype` can specify any valid integer type.

Data Types

char

N - Number of bits kept

nonnegative integer | nonnegative integer array

Number of bits kept, specified as a nonnegative integer or integer array. N must be less than or equal to the number of bits in the unsigned integer class of A.

Data Types

double | int8 | int16 | int32 | int64 | uint8 | uint16 | uint32 | uint64

Output Arguments**intout - Shifted value**

signed integer array | unsigned integer array | double array

Shifted value, returned as signed integer array, unsigned integer array, or double array. `intout` is the same size and type as A.

Examples**Shifted 8-bit Integer**

Repeatedly shift the bits of an unsigned 8-bit value to the left until all the nonzero bits overflow.

```
a = intmax('uint8');
s1 = 'Initial uint8 value %5d is %08s in binary\n';
s2 = 'Shifted uint8 value %5d is %08s in binary\n';
fprintf(s1,a,dec2bin(a))
for i = 1:8
    a = bitshift(a,1);
    fprintf(s2,a,dec2bin(a))
end
```

```
Initial uint8 value    255 is 11111111 in binary
Shifted uint8 value   254 is 11111110 in binary
Shifted uint8 value   252 is 11111100 in binary
Shifted uint8 value   248 is 11111000 in binary
Shifted uint8 value   240 is 11110000 in binary
Shifted uint8 value   224 is 11100000 in binary
Shifted uint8 value   192 is 11000000 in binary
Shifted uint8 value   128 is 10000000 in binary
```

bitshift

Shifted uint8 value 0 is 00000000 in binary

Different Results for Different Integer Types

Find the shift for a number using different assumed integer types.

```
uintout = bitshift(6,5:7,'uint8')
intout = bitshift(6,5:7,'int8')
```

uintout =

```
192 128 0
```

intout =

```
-64 -128 0
```

See Also

[bitand](#) | [bitcmp](#) | [bitget](#) | [bitor](#) | [bitset](#) | [bitxor](#) | [intmax](#)

Purpose

Bit-wise XOR

Syntax

```
intout = bitxor(integ1,integ2)
intout = bitxor(integ1,integ2,assumedtype)

objout = bitxor(netobj1,netobj2)
```

Description

`intout = bitxor(integ1,integ2)` returns the bit-wise XOR of `integ1` and `integ2`.

`intout = bitxor(integ1,integ2,assumedtype)` assumes that `integ1` and `integ2` are of `assumedtype`.

`objout = bitxor(netobj1,netobj2)` returns the bit-wise XOR of the .NET enumeration objects `netobj1` and `netobj2`.

Input Arguments**integ1, integ2 - Input values**

signed integer arrays | unsigned integer arrays | double arrays

Input values, specified as signed integer arrays, unsigned integer arrays, or double arrays. `integ1` and `integ2` must be the same data type, or one must be a scalar double value.

- If `integ1` and `integ2` are double arrays, and `assumedtype` is not specified, then MATLAB treats `integ1` and `integ2` as unsigned 64-bit integers.
- If `assumedtype` is specified, then all elements in `integ1` and `integ2` must have integer values within the range of `assumedtype`.

Data Types

double | int8 | int16 | int32 | int64 | uint8 | uint16 | uint32 | uint64

assumedtype - Assumed data type of integ1 and integ2

'uint64' | 'uint32' | 'uint16' | 'uint8' | 'int64' | 'int32' | 'int16' | 'int8'

Assumed data type of `integ1` and `integ2`, specified as `'uint64'`, `'uint32'`, `'uint16'`, `'uint8'`, `'int64'`, `'int32'`, `'int16'`, or `'int8'`.

- If `integ1` and `integ2` are double arrays, then `assumedtype` can specify any valid integer type, but defaults to `'uint64'`.
- If `integ1` and `integ2` are integer type arrays, then `assumedtype` must specify that same integer type.

Data Types

`char`

`netobj1`, `netobj2` - Input values

`.NET` enumeration objects

Input values, specified as `.NET` enumeration objects. You must be running a version of Windows to use `.NET` enumeration objects as input arguments.

`bitxor` is an instance method for MATLAB enumeration objects created from a `.NET` enumeration.

Output Arguments

`intout` - Bit-wise XOR result

signed integer array | unsigned integer array | double array

Bit-wise XOR result, returned as a signed integer array, unsigned integer array, or double array. `intout` is the same data type and size as `integ1` and `integ2`.

- If either `integ1` or `integ2` is a scalar double, and the other is a non-double integer type, `intout` is the non-double integer type.

`objout` - Bit-wise XOR result

`.NET` enumeration object

Bit-wise XOR result, returned as a `.NET` enumeration objects.

Examples

Truth Table

Create a truth table for the logical XOR operation.

```
A = uint8([0 1; 0 1]);
B = uint8([0 0; 1 1]);
TTable = bitxor(A, B)
```

```
TTable =

     0     1
     1     0
```

bitxor returns 0 if both bit-wise inputs are equal.

Negative Values

Explore how bitxor handles negative values.

MATLAB encodes negative integers using two's complement. Thus, the bit-wise XOR of -5 (11111010) and 6 (00000110) is -3 (11111100).

```
C = -5;
D = 6;
bitxor(C,D,'int8')
```

```
ans =

    -3
```

See Also

bitand | bitcmp | bitget | bitor | bitnot | bitshift | bitset | intmax

Related Examples

- “Creating .NET Enumeration Bit Flags”

blanks

Purpose Create string of blank characters

Syntax `blanks(n)`

Description `blanks(n)` is a string of `n` blanks.

Examples `blanks` is useful with the `display` function. For example,

```
disp(['xxx' blanks(20) 'yyy'])
```

displays twenty blanks between the strings 'xxx' and 'yyy'.
`disp(blanks(n) ' ')` moves the cursor down `n` lines.

See Also `clc` | `format` | `home`

Purpose Construct block diagonal matrix from input arguments

Syntax `out = blkdiag(a,b,c,d,...)`

Description `out = blkdiag(a,b,c,d,...)`, where `a`, `b`, `c`, `d`, ... are matrices, outputs a block diagonal matrix of the form

$$\begin{bmatrix} a & 0 & 0 & 0 & 0 \\ 0 & b & 0 & 0 & 0 \\ 0 & 0 & c & 0 & 0 \\ 0 & 0 & 0 & d & 0 \\ 0 & 0 & 0 & 0 & \dots \end{bmatrix}$$

The input matrices do not have to be square, nor do they have to be of equal size.

See Also `diag` | `horzcat` | `vertcat`

box

Purpose Axes border

Syntax `box on`
`box off`
`box`
`box(axes_handle,...)`

Description `box on` displays the boundary of the current axes.
`box off` does not display the boundary of the current axes.
`box` toggles the visible state of the current axes boundary.
`box(axes_handle,...)` uses the axes specified by `axes_handle` instead of the current axes.

Algorithms The `box` function sets the axes `Box` property to on or off.

See Also `axes | grid`

Purpose	Terminate execution of for or while loop
Syntax	<code>break</code>
Description	<p><code>break</code> terminates the execution of a for or while loop. Statements in the loop that appear after the <code>break</code> statement are not executed.</p> <p>In nested loops, <code>break</code> exits only from the loop in which it occurs. Control passes to the statement that follows the end of that loop.</p>
Tips	<code>break</code> is not defined outside a for or while loop. Use <code>return</code> in this context instead.
Examples	<p>The example below shows a while loop that reads the contents of the file <code>fft.m</code> into a MATLAB character array. A <code>break</code> statement is used to exit the while loop when the first empty line is encountered. The resulting character array contains the command line help for the <code>fft</code> program.</p> <pre>fid = fopen('fft.m','r'); s = ''; while ~feof(fid) line = fgetl(fid); if isempty(line) ~ischar(line) break end s = sprintf('%s%s\n', s, line); end disp(s); fclose(fid);</pre>
See Also	<code>for</code> <code>while</code> <code>end</code> <code>continue</code> <code>return</code>

brighten

Purpose Brighten or darken colormap

Syntax
`brighten(beta)`
`brighten(h,beta)`
`newmap = brighten(beta)`
`newmap = brighten(cmap,beta)`

Description `brighten(beta)` increases or decreases the color intensities in a colormap by replacing the current colormap with a brighter or darker colormap of essentially the same colors. The modified colormap is brighter if $0 < \text{beta} < 1$ and darker if $-1 < \text{beta} < 0$. `brighten(beta)`, followed by `brighten(-beta)`, where $\text{beta} < 1$, restores the original map.

`brighten(h,beta)` brightens all objects that are children of the figure having the handle `h`.

`newmap = brighten(beta)` returns a brighter or darker version of the current colormap without changing the display.

`newmap = brighten(cmap,beta)` returns a brighter or darker version of the colormap `cmap` without changing the display.

Examples

Brighten Colormap

Display a surface plot of membrane.

```
surf(membrane);
```

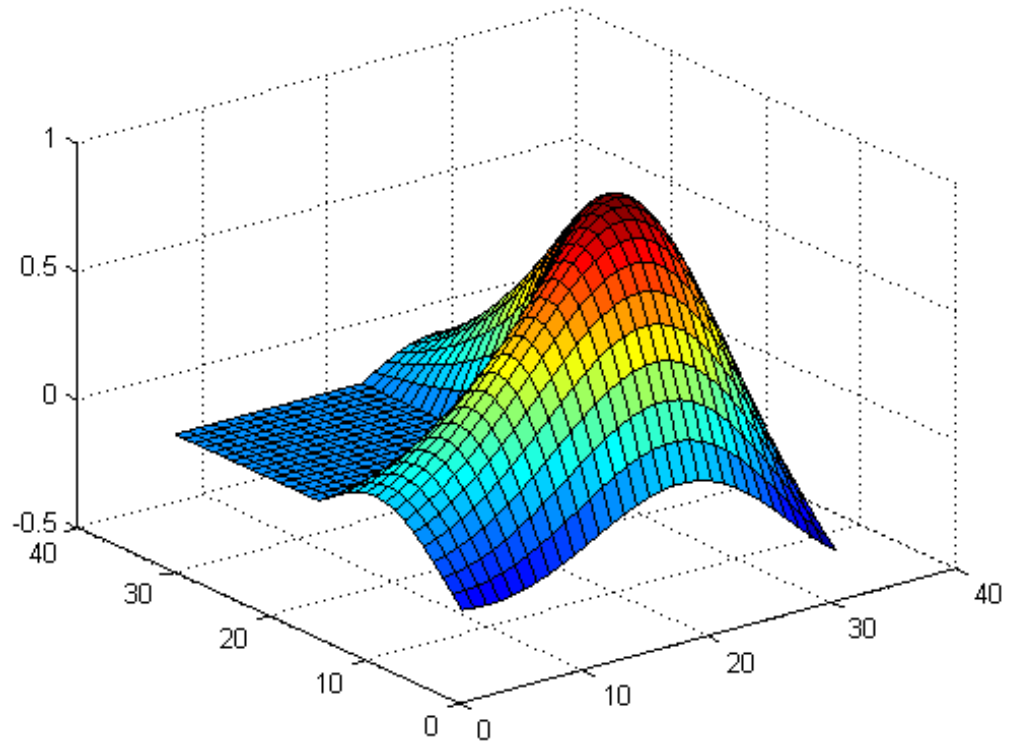

Brighten the colormap.

```
beta = .7;  
brighten(beta);
```

brighten

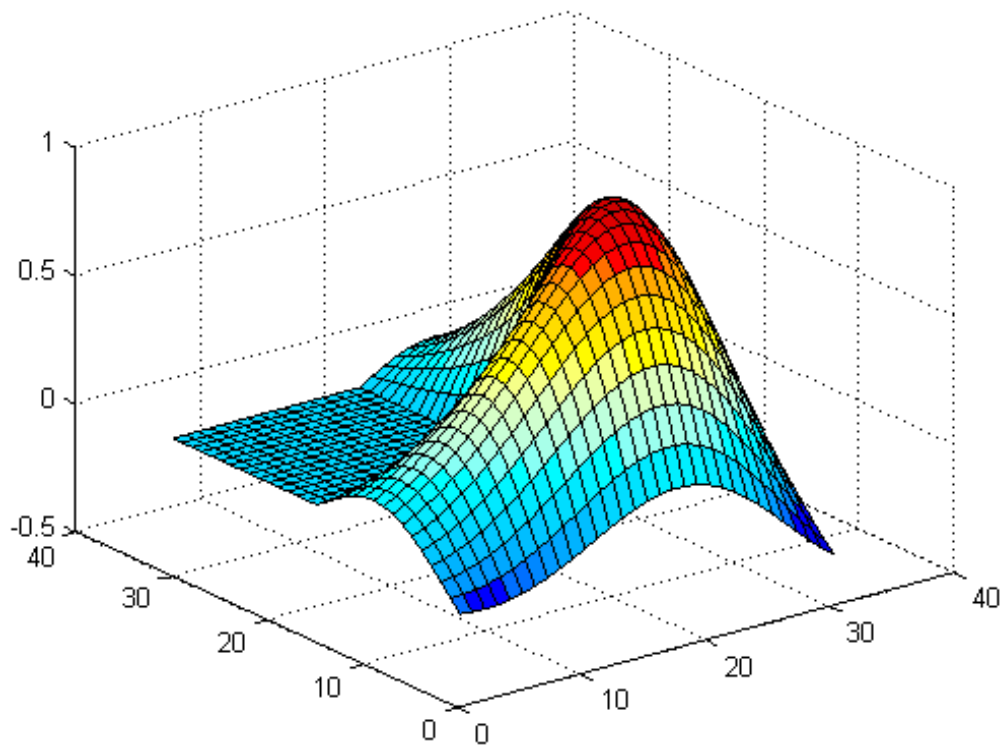

Algorithms

`brighten` raises values in the colormap to the power of gamma, where gamma is

$$\gamma = \begin{cases} 1 - \beta, & \beta > 0 \\ \frac{1}{1 + \beta}, & \beta \leq 0 \end{cases}$$

`brighten` has no effect on graphics objects defined with true color.

See Also `colormap` | `rgbplot`

How To

- “Altering Colormaps”

brush

Purpose Interactively mark, delete, modify, and save observations in graphs

Syntax

```
brush on
brush off
brush
brush color
brush(figure_handle,...)
brushobj = brush(figure_handle)
```

Description Data brushing is a mode for interacting with graphs in figure windows in which you can click data points or drag a selection rectangle around data points to highlight observations in a color of your choice. Highlighting takes different forms for different types of graphs, and brushing marks persist—even in other interactive modes—until removed by deselecting them.

`brush on` turns on interactive data brushing mode.

`brush off` turns brushing mode off, leaving any brushed observations still highlighted.

`brush` by itself toggles the state of the data brushing tool.

`brush color` sets the current color used for brushing graphics to the specified `ColorSpec`. Changing brush color affects subsequent brushing, but does not change the color of observations already brushed or the brush tool's state.

`brush(figure_handle,...)` applies the function to the specified figure handle.

`brushobj = brush(figure_handle)` returns a *brush mode object* for that figure, useful for controlling and customizing the figure's brushing state. The following properties of such objects can be modified using `get` and `set`:

Enable 'on' { 'off' }	Specifies whether this figure mode is currently enabled on the figure.
FigureHandle	The associated figure handle. This property supports get only.
Color	Specifies the color to be used for brushing.

brush cannot return a brush mode object at the same time you are calling it to set a brushing option.

Tips

- “Types of Plots You Can Brush” on page 1-591
- “Plot Types You Cannot Brush” on page 1-593
- “Mode Exclusivity and Persistence” on page 1-594
- “How Data Linking Affects Data Brushing” on page 1-595
- “Mouse Gestures for Data Brushing” on page 1-596
- “Brush Mode Callbacks” on page 1-597

Types of Plots You Can Brush

Data brushing places lines and patches on plots to create highlighting, marking different types of graphs as follows (brushing marks are shown in red):

brush

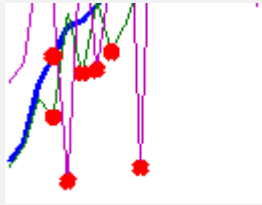
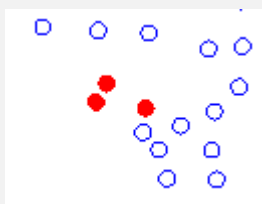
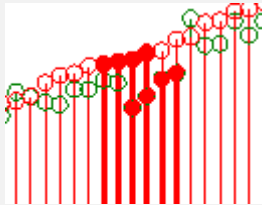
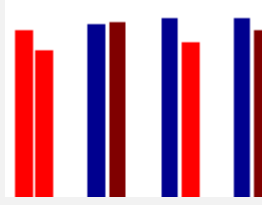
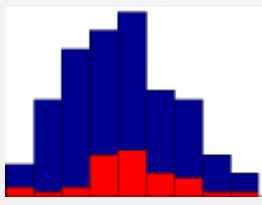
Graph Type	Brushing Annotation	Overlays?	Example
lineseries	Colored lines slightly wider than those in the lineseries with a marker distinct from those on the lineseries (filled circles if none) to identify brushed vertices. Only those line segments that connect brushed vertices are highlighted	Y	
scattergroup	Line with LineStyle 'none' and a marker with a color distinct from and slightly larger than the base scattergroup marker.	Y	
stemseries	The brushed stems and stem heads are shaded in the brushing color.	Y	
barseries	The interior of selected bars is filled in the brushing color.	N	
histogram	The bars to which brushed observations contribute are proportionately filled from the bottom up with the brushing color.	N	

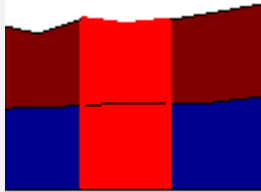
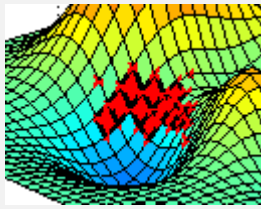
Graph Type	Brushing Annotation	Overlays?	Example
areaseries	Patches filling the region between selected points and the x -axis in the brushing color.	N	
surfaceplot	Patches with edges slightly wider than the surfaceplot line width and with a marker distinct from that of the surfaceplot (X if none) to identify brushed vertices. Patches are plotted only when all four vertices that define them are brushed. The brushed observations are the set of marked vertices, not the patches.	N	

When using the linked plots feature, a graph can become brushed when you brush another graph that displays some of the same data, potentially brushing the same observations more than once. The overlaid brushing marks (whether lines or markers) are slightly wider than the brushing marks that they overlay; this makes multiply brushed observations visually distinct. The wider brushing marks are placed under the narrower ones, so that if they happen to have different colors, you can see all the colors. See the subsection “How Data Linking Affects Data Brushing” on page 1-595 for more information about brushing linked figures.

As the above table indicates, only lineseries, scatterseries, and stemseries brushing marks can be overlaid in this manner. Although you can brush them, you cannot overlay brushing marks on areaseries, barseries, histograms, or surfaceplots.

Plot Types You Cannot Brush

Currently, not all plot types enable data brushing. Graph functions that *do not* support brushing are:

- Line plots created with `line`
- Scatter plots created with `spy`
- Contour plots created with `contour`, `contourf`, or `contour3`
- Pie charts created with `pie` or `pie3`
- Radial graphs created with `polar`, `compass`, or `rose`
- Direction graphs created with `feather`, `quiver`, or `comet`
- Area and image plots created with `fill`, `image`, `imagesc`, or `pcolor`
- Bar graphs created with `pareto` or `errorbar`
- Functional plots created with `ezcontour` or `ezcontourf`
- 3-D plot types *other than* `plot3`, `stem3`, `scatter3`, `mesh`, `meshc`, `surf`, `surf1`, and `surfc`

You can use some of these functions to display base data that do not need to be brushable. For example, use `line` to plot mean y -values as horizontal lines that you do not need or want to brush.

Mode Exclusivity and Persistence

Data brushing mode is *exclusive*, like zoom, pan, data cursor, or plot edit mode. However, brush marks created in data brushing mode *persist* through all changes in mode. Brush marks that appear in other graphs while they are linked via `linkdata` also persist even when data linking is subsequently turned off. That is, severing connections to a graph's data sources does not remove brushing marks from it. The only ways to remove brushing marks are (in brushing mode):

- Brush an empty area in a brushed graph.
- Right-click and select **Clear all brushing** from the context menu.

Changing the brushing color for a figure does not recolor brushing marks on it until you brush it again. If you hold down the **Shift** key, all existing brush marks change to the new color. All brush marks that appear on linked plots in the same or different figure also change to the new color if the brushing action affects them. The behavior is the same whether you select a brushing color from the Brush Tool dropdown palette, set

it by calling `brush(colorspec)`, or by setting the `Color` property of a brush mode object (e.g., `set(brushobj, 'Color', colorspec)`).

How Data Linking Affects Data Brushing

When you use the Data Linking tool or call the `linkdata` function, brushing marks that you make on one plot appear on other plots that depict the same variable you are brushing—if those plots are also linked. This happens even if the affected plot is not in Brushing mode. That is, brushing marks appear on a linked plot *in any mode* when you brush another plot linked to it via a common variable or brush that variable in the Variables editor. Be aware that the following conditions apply, however:

- The graph type must support data brushing (see “Types of Plots You Can Brush” on page 1-591 and “Plot Types You Cannot Brush” on page 1-593)
- The graphed variable must not be complex; if you can plot a complex variable you can brush it, but such graphs do not respond when you brush the complex variable in another linked plot. For more information about linking complex variables, see Example 3 in the `linkdata` reference page.
- Observations that you brush display in the same color in all linked graphs. The color is the brush color you have selected in the window you are interacting with, and can differ from the brushing colors selected in the other affected figures. When you brush linked plots, the brushing color is associated with the variable(s) you brush

The last bullet implies that brush marks on an unlinked graph can change color when data linking is turned on for that figure. Brushing marks can, in fact, vanish and be replaced by marks in the same or different color when the plot enters a linked state. In the linked state, brushing is tied to variables (data sources), not just the graphics. If different observations for the same variable on a linked figure are brushed, those variables override the brushed graphics on the newly linked plot. In other words, the newly linked graph loses all its previous brush marks when it “joins the club” of common data sources.

Mouse Gestures for Data Brushing

You can brush graphs in several ways. The basic operation is to drag the mouse to highlight all observations within the rectangle you define. The following table lists data brushing gestures and their effects.

Action	Gesture	Result
Select data using a region of interest	ROI mouse drag	Region of interest (ROI) rectangle (or rectangular prism for 3-D axes) appears during the gesture and all brushable observations within the rectangle are highlighted. All other brushing marks in the axes are removed. The ROI rectangle disappears when the mouse button is released.
Select a single point	Single left-click on a graphic object that supports data brushing	Produces an equivalent result to ROI rectangle, brushing where the rectangle encloses only the single vertex on the graphical object closest to the mouse. All other brushing annotations in the figure are removed.
Add a point to the selection or remove a highlighted one	Single left-click on a graphic object that supports data brushing, with the Shift key down	Equivalent brushing by dragging an ROI rectangle that encloses only the single vertex on the graphic object closest to the mouse. All other brushed regions in the figure remain brushed.
Select all data associated with a graphic object	Double left-click on a graphic object that supports data brushing	All vertices for the graphic object are brushed.

Action	Gesture	Result
Add to or subtract from region of interest	Click or ROI drag with the Shift or Ctrl keys down	Region of interest grows; all unbrushed vertices within the rectangle become brushed and all brushed observations in it become unbrushed. All brushed vertices outside the ROI remain brushed.
Copy brushed data to Editor, Command Window, Variables editor, or Workspace Browser	Drag brushed data to another window or to a program/icon on the system desktop	Equivalent to copying brushed data and pasting into other window or an existing/new variable.

Brush Mode Callbacks

You can program the following callbacks for brush mode operations.

- **ActionPreCallback** <function_handle> — Function to execute before brushing

Use this callback to execute code when a brush operation begins. The function handle should reference a function with two implicit arguments:

```
function myfunction(obj,event_obj)
% obj          handle to the figure that has been clicked
% event_obj    object containing struct of event data
```

The event data struct has the following field:

Axes	The handle of the axes that is being brushed
------	--

brush

- `ActionPostCallback` <function_handle> — Function to execute after brushing

Use this callback to execute code when a brush operation ends. The function handle should reference a function with two implicit arguments:

```
function myfunction(obj,event_obj)
% obj          handle to the figure that has been clicked
% event_obj    object containing struct of event data
%              (same as the event data of the
%              'ActionPreCallback' callback)
```

Examples

Example 1

On a scatterplot, drag out a rectangle to brush the graph:

```
x = rand(20,1);
y = rand(20,1);
scatter(x,y,80,'s')
brush on
```

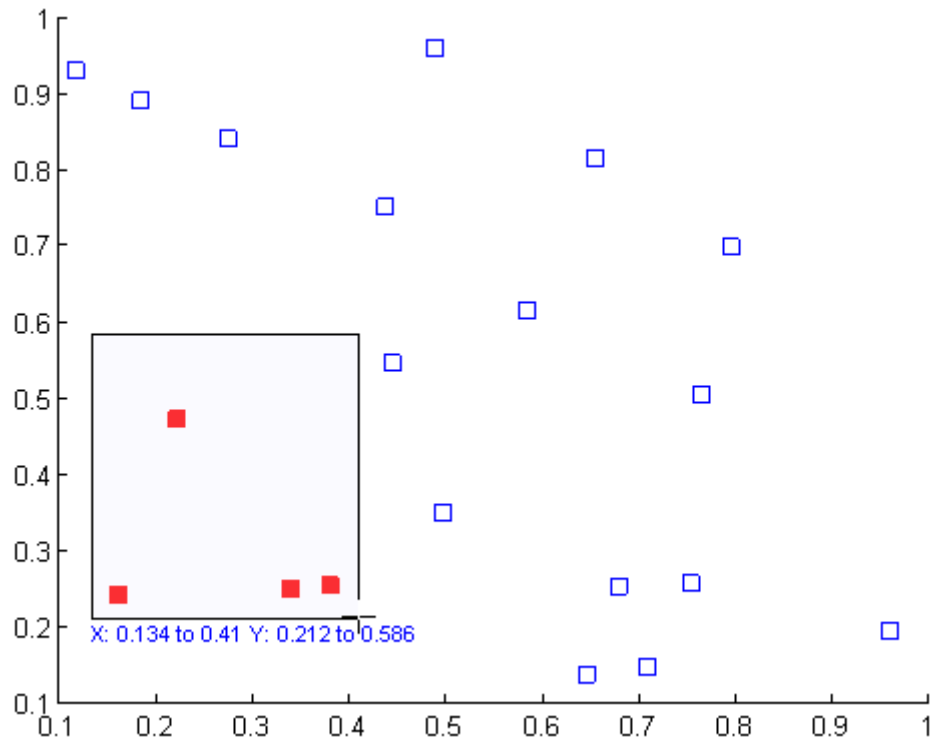



Example 2

Brush observations from $-.2$ to $.2$ on a lineseries plot in dark red:

```
x = [-2*pi:.1:2*pi];  
y = sin(x);  
plot(x,y);  
h = brush;  
set(h, 'Color', [.6 .2 .1], 'Enable', 'on');
```

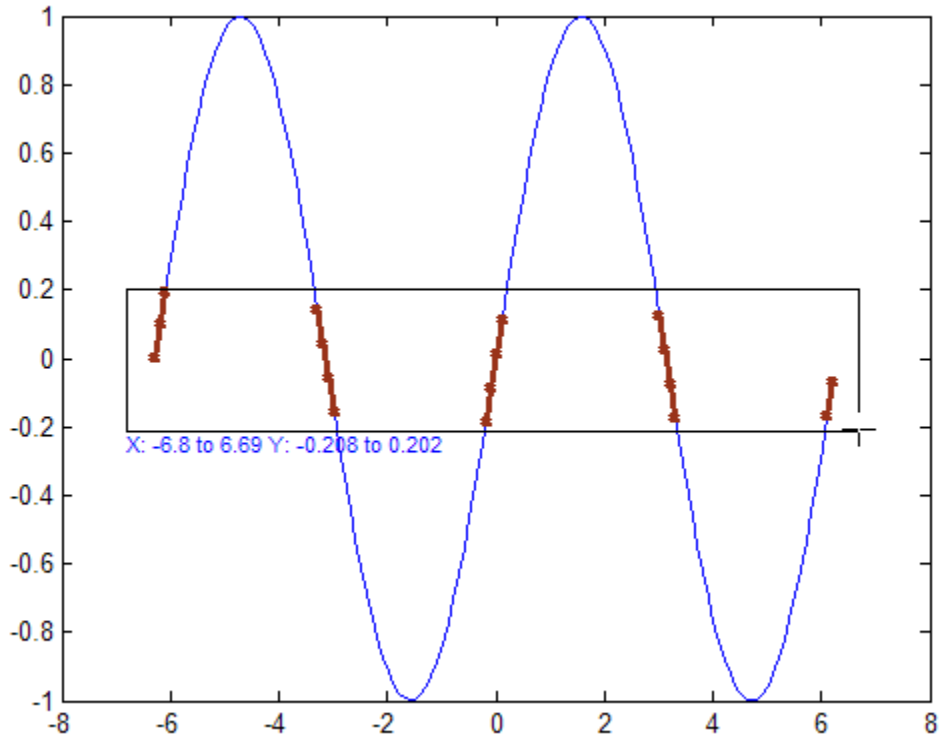
brush



See Also

[linkaxes](#) | [linkdata](#) | [pan](#) | [rotate3d](#) | [zoom](#)

How To

- “Marking Up Graphs with Data Brushing”

Purpose Apply element-by-element binary operation to two arrays with singleton expansion enabled

Syntax `C = bsxfun(fun,A,B)`

Description `C = bsxfun(fun,A,B)` applies the element-by-element binary operation specified by the function handle `fun` to arrays `A` and `B`, with singleton expansion enabled. `fun` can be one of the following built-in functions:

@plus	Plus
@minus	Minus
@times	Array multiply
@rdivide	Right array divide
@ldivide	Left array divide
@power	Array power
@max	Binary maximum
@min	Binary minimum
@rem	Remainder after division
@mod	Modulus after division
@atan2	Four-quadrant inverse tangent; result in radians
@atan2d	Four-quadrant inverse tangent; result in degrees
@hypot	Square root of sum of squares
@eq	Equal
@ne	Not equal
@lt	Less than
@le	Less than or equal to
@gt	Greater than

@ge	Greater than or equal to
@and	Element-wise logical AND
@or	Element-wise logical OR
@xor	Logical exclusive OR

`fun` can also be a handle to any binary element-wise function not listed above. A binary element-wise function of the form `C = fun(A,B)` accepts arrays `A` and `B` of arbitrary, but equal size and returns output of the same size. Each element in the output array `C` is the result of an operation on the corresponding elements of `A` and `B` only. `fun` must also support scalar expansion, such that if `A` or `B` is a scalar, `C` is the result of applying the scalar to every element in the other input array.

The corresponding dimensions of `A` and `B` must be equal to each other or equal to one. Whenever a dimension of `A` or `B` is singleton (equal to one), `bsxfun` virtually replicates the array along that dimension to match the other array. In the case where a dimension of `A` or `B` is singleton, and the corresponding dimension in the other array is zero, `bsxfun` virtually diminishes the singleton dimension to zero.

The size of the output array `C` is equal to:
`max(size(A),size(B)).*(size(A)>0 & size(B)>0)`.

Examples

Deviations from Mean

Use `bsxfun` to subtract the column mean from the corresponding column elements of a matrix, `A`.

```
A = [1 2 10; 1 4 20; 1 6 15] ;  
C = bsxfun(@minus, A, mean(A))
```

```
C =  
  
    0    -2    -5  
    0     0     5  
    0     2     0
```

Singleton Expansion with Custom Function

Call a custom-defined binary function with `bsxfun` by specifying a handle to the function.

```
fun = @(A,B) A.*sin(B);
A = 1:7;
B = pi*[0 1/4 1/3 1/2 2/3 3/4 1].';
C = bsxfun(fun,A,B)
```

C =

	0	0	0	0	0	0	0
	0.7071	1.4142	2.1213	2.8284	3.5355	4.2426	4.9497
	0.8660	1.7321	2.5981	3.4641	4.3301	5.1962	6.0622
	1.0000	2.0000	3.0000	4.0000	5.0000	6.0000	7.0000
	0.8660	1.7321	2.5981	3.4641	4.3301	5.1962	6.0622
	0.7071	1.4142	2.1213	2.8284	3.5355	4.2426	4.9497
	0.0000	0.0000	0.0000	0.0000	0.0000	0.0000	0.0000

Singleton expansion allows `bsxfun` to expand the input vectors into a full matrix.

See Also

[repmat](#) | [arrayfun](#)

builddocsearchdb

Purpose Build searchable documentation database

Syntax `builddocsearchdb(folder)`

Description `builddocsearchdb(folder)` builds a searchable database from HTML files in the specified folder. The `builddocsearchdb` function creates a subfolder named `helpsearch` to contain the database files. The database enables MATLAB to search for content within the HTML files, as long as the version of MATLAB is the same as the version used to create the database.

Input Arguments **folder - Full path to folder with HTML files**
`string`

Full path to a folder with HTML files, specified as a string.

To include a particular HTML document in the search database, the `builddocsearchdb` function requires that:

- The document has a title.
- The content is different from the title.

Example: `builddocsearchdb('c:\myfiles\html')`

Examples **Search Custom Help Files**

Build a search database for custom help files.

MATLAB includes a set of sample files to demonstrate how to create a custom toolbox and supporting documentation. This sample toolbox is called the *Upslope Area Toolbox*. The `upslope` folder includes a file named `info.xml`, which is required to display custom documentation, and a subfolder named `html`, which contains HTML documentation and supporting files.

Copy the sample files to a temporary folder, and add the copied files to the path.

```
sample = fullfile(...
```

```
matlabroot,'help','techdoc','matlab_env',...  
    'examples','upslope');  
tmp = tempname;  
mkdir(tmp);  
copyfile(sample,tmp);  
addpath(tmp);
```

Create a search database.

```
folder = fullfile(tmp,'html');  
builddocsearchdb(folder)
```

Open the Supplemental Software documentation browser. There is a link to this browser at the bottom of the documentation home page.

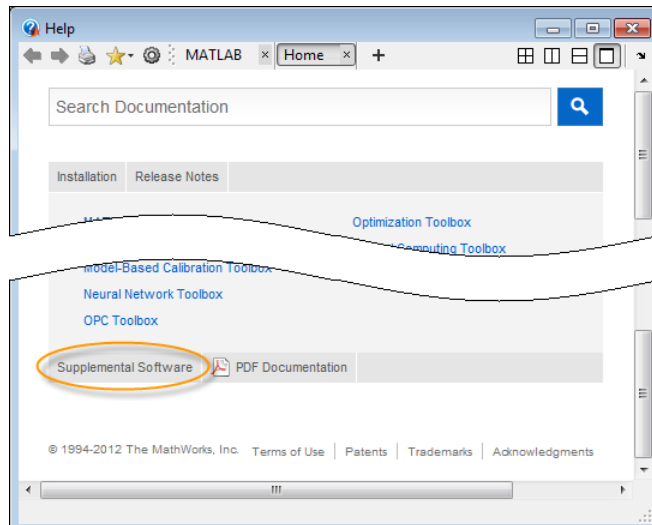

Search the supplemental documentation for the term *tarboton*, which appears in several of the example help files. The search returns several results from the Upslope Area Toolbox.

builddocsearchdb

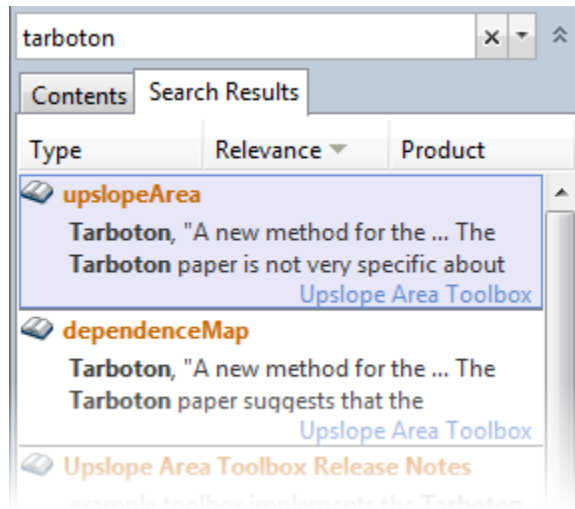

Remove the temporary example files.

```
rmpath(tmp)
rmdir(tmp, 's')
```

See Also

doc | help

Concepts

- “Display Custom Documentation”

Purpose	Execute built-in function from overloaded method
Syntax	<code>builtin(function,x1,...,xn)</code> <code>[y1,...,yn] = builtin(function,x1,...,xn)</code>
Description	<code>builtin(function,x1,...,xn)</code> executes the built-in function with the input arguments <code>x1</code> through <code>xn</code> . Use <code>builtin</code> to execute the original built-in from within a method that overloads the function. To work properly, you must never overload <code>builtin</code> .

`[y1,...,yn] = builtin(function,x1,...,xn)` stores any output from function in `y1` through `yn`.

Input Arguments	function - Built-in function name string
	Valid built-in function name in the MATLAB path, specified as a string. function cannot be a function handle.
	x1,...,xn - Valid input arguments for function supported data types
	Valid input arguments for function, specified by supported data types.

Examples **Run an Overloaded Function within a Class Definition**

Execute the built-in functionality from within an overloaded method.

Create a simple class describing the speed of a particle and providing a `disp` method by pasting the following code into a file called `MyParticle.m`.

```
classdef MyParticle
    properties
        velocity;
    end
    methods
        function p = MyParticle(x,y,z)
```

builtin

```
        p.velocity.x = x;  
        p.velocity.y = y;  
        p.velocity.z = z;  
    end  
    function disp(p)  
        builtin('disp',p) %call builtin  
        if isscalar(p)  
            disp(' Velocity')  
            disp([' x: ',num2str(p.velocity.x)])  
            disp([' y: ',num2str(p.velocity.y)])  
            disp([' z: ',num2str(p.velocity.z)])  
        end  
    end  
end  
end
```

Create an instance MyParticle.

```
p = MyParticle(1,2,4)
```

```
p =
```

```
MyParticle
```

```
Properties:
```

```
velocity: [1x1 struct]
```

```
Methods
```

```
Velocity
```

```
x: 1
```

```
y: 2
```

```
z: 4
```

Definitions

built-in function

A built-in function is part of the MATLAB executable. MATLAB does not implement these functions in the MATLAB language. Although

most built-in functions have a `.m` file associated with them, this file only supplies documentation for the function.

You can use the syntax `which function` to check whether a function is built-in.

See Also

`feval` | `which`

bvp4c

Purpose Solve boundary value problems for ordinary differential equations

Syntax

```
sol = bvp4c(odefun,bcfun,solinit)
sol = bvp4c(odefun,bcfun,solinit,options)
solinit = bvpinit(x, yinit, params)
```

Arguments

odefun	<p>A function handle that evaluates the differential equations $f(x,y)$. It can have the form</p> <pre>dydx = odefun(x,y) dydx = odefun(x,y,parameters)</pre> <p>For a scalar x and a column vector y, <code>odefun(x,y)</code> must return a column vector, <code>dydx</code>, representing $f(x,y)$. <code>parameters</code> is a vector of unknown parameters.</p>
bcfun	<p>A function handle that computes the residual in the boundary conditions. For two-point boundary value conditions of the form $bc(y(a),y(b))$, <code>bcfun</code> can have the form</p> <pre>res = bcfun(ya,yb) res = bcfun(ya,yb,parameters)</pre> <p>where <code>ya</code> and <code>yb</code> are column vectors corresponding to $y(a)$ and $y(b)$. <code>parameters</code> is a vector of unknown parameters. The output <code>res</code> is a column vector.</p> <p>See “Multipoint Boundary Value Problems” on page 1-613 for a description of <code>bcfun</code> for multipoint boundary value problems.</p>
solinit	<p>A structure containing the initial guess for a solution. You create <code>solinit</code> using the function <code>bvpinit</code>. <code>solinit</code> has the following fields.</p>

	x	Ordered nodes of the initial mesh. Boundary conditions are imposed at $a = \text{solinit.x}(1)$ and $b = \text{solinit.x}(\text{end})$.
	y	Initial guess for the solution such that $\text{solinit.y}(:,i)$ is a guess for the solution at the node $\text{solinit.x}(i)$.
	parameters	Optional. A vector that provides an initial guess for unknown parameters.
	The structure can have any name, but the fields must be named x, y, and parameters. You can form solinit with the helper function <code>bvpinit</code> . See <code>bvpinit</code> for details.	
options	Optional integration argument. A structure you create using the <code>bvpset</code> function. See <code>bvpset</code> for details.	

Description

`sol = bvp4c(odefun,bcfun,solinit)` integrates a system of ordinary differential equations of the form

$$y' = f(x,y)$$

on the interval $[a,b]$ subject to two-point boundary value conditions $bc(y(a),y(b)) = 0$.

`odefun` and `bcfun` are function handles. See the `function_handle` reference page for more information.

“Parameterizing Functions” explains how to provide additional parameters to the function `odefun`, as well as the boundary condition function `bcfun`, if necessary.

`bvp4c` can also solve multipoint boundary value problems. See “Multipoint Boundary Value Problems” on page 1-613. You can use the function `bvpinit` to specify the boundary points, which are stored in the input argument `solinit`. See the reference page for `bvpinit` for more information.

The `bvp4c` solver can also find unknown parameters p for problems of the form

$$y' = f(x, y, p)$$

$$0 = bc(y(a), y(b), p)$$

where p corresponds to parameters. You provide `bvp4c` an initial guess for any unknown parameters in `solinit.parameters`. The `bvp4c` solver returns the final values of these unknown parameters in `sol.parameters`.

`bvp4c` produces a solution that is continuous on $[a, b]$ and has a continuous first derivative there. Use the function `deval` and the output `sol` of `bvp4c` to evaluate the solution at specific points `xint` in the interval $[a, b]$.

```
sol = deval(sol, xint)
```

The structure `sol` returned by `bvp4c` has the following fields:

<code>sol.x</code>	Mesh selected by <code>bvp4c</code>
<code>sol.y</code>	Approximation to $y(x)$ at the mesh points of <code>sol.x</code>
<code>sol.yp</code>	Approximation to $y'(x)$ at the mesh points of <code>sol.x</code>
<code>sol.parameters</code>	Values returned by <code>bvp4c</code> for the unknown parameters, if any
<code>sol.solver</code>	' <code>bvp4c</code> '
<code>sol.stats</code>	Computational cost statistics (also displayed when the <code>stats</code> option is set with <code>bvpset</code>).

The structure `sol` can have any name, and `bvp4c` creates the fields `x`, `y`, `yp`, `parameters`, and `solver`.

`sol = bvp4c(odefun,bcfun,solinit,options)` solves as above with default integration properties replaced by the values in `options`, a structure created with the `bvpset` function. See `bvpset` for details.

`solinit = bvpinit(x, yinit, params)` forms the initial guess `solinit` with the vector `params` of guesses for the unknown parameters.

Singular Boundary Value Problems

`bvp4c` solves a class of singular boundary value problems, including problems with unknown parameters `p`, of the form

$$y' = S \cdot y/x + F(x,y,p)$$

$$0 = bc(y(0),y(b),p)$$

The interval is required to be $[0, b]$ with $b > 0$. Often such problems arise when computing a smooth solution of ODEs that result from partial differential equations (PDEs) due to cylindrical or spherical symmetry. For singular problems, you specify the (constant) matrix `S` as the value of the 'SingularTerm' option of `bvpset`, and `odefun` evaluates only $f(x,y,p)$. The boundary conditions must be consistent with the necessary condition $S \cdot y(0) = 0$ and the initial guess should satisfy this condition.

Multipoint Boundary Value Problems

`bvp4c` can solve multipoint boundary value problems where $a = a_0 < a_1 < a_2 < \dots < a_n = b$ are boundary points in the interval $[a,b]$. The points a_1, a_2, \dots, a_{n-1} represent interfaces that divide $[a,b]$ into regions. `bvp4c` enumerates the regions from left to right (from a to b), with indices starting from 1. In region k , $[a_{k-1}, a_k]$, `bvp4c` evaluates the derivative as

$$yp = \text{odefun}(x,y,k)$$

In the boundary conditions function

$$\text{bcfun}(yleft,yright)$$

`yleft(:,k)` is the solution at the left boundary of $[a_{k-1}, a_k]$. Similarly, `yright(:,k)` is the solution at the right boundary of region k . In particular,

```
yleft(:,1) = y(a)
```

and

```
yright(:,end) = y(b)
```

When you create an initial guess with

```
solinit = bvpinit(xinit,yinit),
```

use double entries in `xinit` for each interface point. See the reference page for `bvpinit` for more information.

If `yinit` is a function, `bvpinit` calls `y = yinit(x,k)` to get an initial guess for the solution at `x` in region `k`. In the solution structure `sol` returned by `bvp4c`, `sol.x` has double entries for each interface point. The corresponding columns of `sol.y` contain the left and right solution at the interface, respectively.

To see an example that solves a three-point boundary value problem, type `threebvp` at the MATLAB command prompt.

Note The `bvp5c` function is used exactly like `bvp4c`, with the exception of the meaning of error tolerances between the two solvers. If $S(x)$ approximates the solution $y(x)$, `bvp4c` controls the residual $|S'(x) - f(x,S(x))|$. This controls indirectly the true error $|y(x) - S(x)|$. `bvp5c` controls the true error directly. `bvp5c` is more efficient than `bvp4c` for small error tolerances.

Examples

Using Initial Guess to Indicate Desired Solution

Boundary value problems can have multiple solutions. One purpose of the initial guess is to indicate which solution, among several, that you want.

The second-order differential equation

$$y'' + |y| = 0$$

has exactly two solutions that satisfy the boundary conditions

$$y(0) = 0,$$

$$y(4) = -2.$$

Before using `bvp4c` to solve the problem, you need to rewrite the differential equation as a system of two first-order ODEs,

$$y_1' = y_2,$$

$$y_2' = -|y_1|,$$

where $y_1 = y$ and $y_2 = y'$. This system has the required form

$$y' = f(x, y),$$

$$bc(y(a), y(b)) = 0.$$

The function, f , and the boundary conditions, bc , are coded in MATLAB as the functions `twoode` and `twobc`.

```
function dydx = twoode(x,y)
dydx = [ y(2); -abs(y(1)) ];
```

```
function res = twobc(ya,yb)
res = [ ya(1); yb(1) + 2 ];
```

Form a guess structure consisting of an initial mesh of five equally spaced points in $[0,4]$ and a guess of the constant values

$$y_1(x) = 1,$$

$$y_2(x) = 0.$$

```
solinit = bvpinit(linspace(0,4,5),[1 0]);
```

Solve the problem using `bvp4c`.

```
sol = bvp4c(@twoode,@twobc,solinit);
```

Evaluate the numerical solution at 100 equally spaced points and plot $y(x)$.

```
x = linspace(0,4);  
y = deval(sol,x);  
plot(x,y(1,:));
```

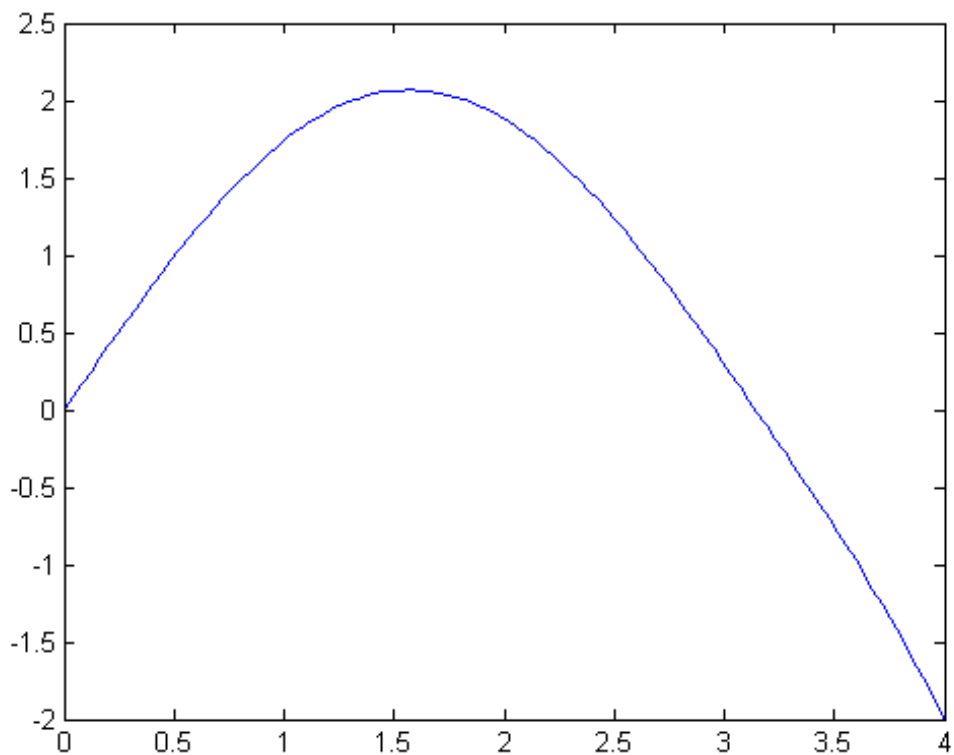

To obtain the other solution of this problem, use the initial guess

$$y_1(x) = -1,$$

$$y_2(x) = 0.$$

```
solinit = bvpinit(linspace(0,4,5),[-1 0]);  
sol = bvp4c(@twoode,@twobc,solinit);  
x = linspace(0,4);  
y = deval(sol,x);
```

```
plot(x,y(1,:));
```

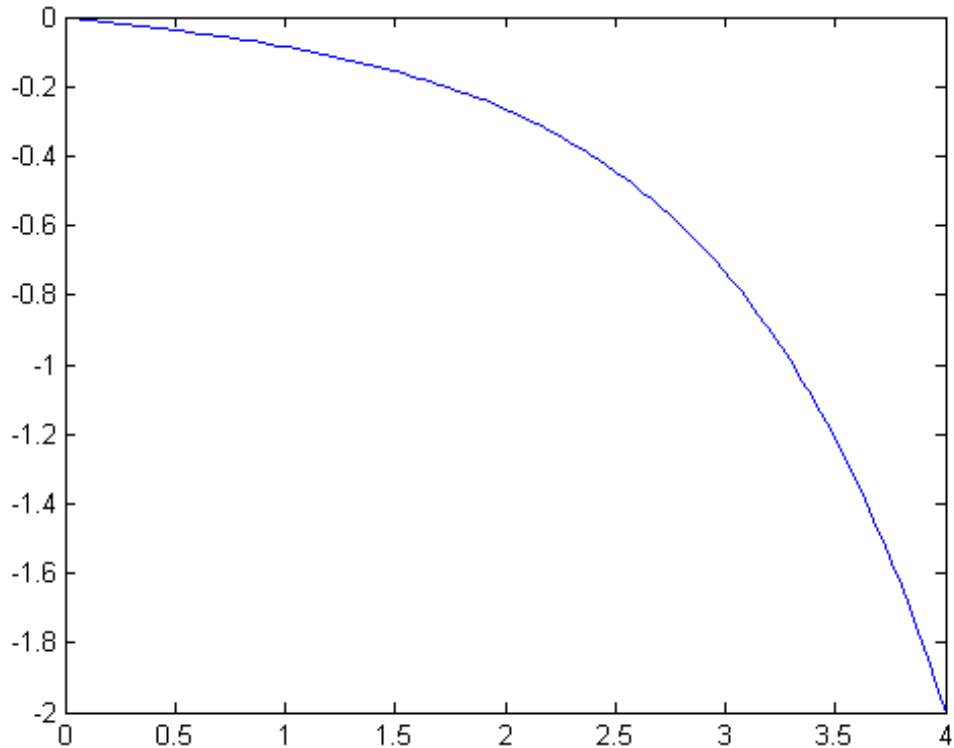

Compute Fourth Eigenvalue of Mathieu's Equation

This boundary value problem involves an unknown parameter. The task is to compute the fourth ($q = 5$) eigenvalue λ of Mathieu's equation

$$y'' + (\lambda - 2q \cos 2x)y = 0.$$

Because the unknown parameter λ is present, this second-order differential equation is subject to *three* boundary conditions:

$$y'(0) = 0$$

$$y'(\pi) = 0$$

$$y(0) = 1$$

It is convenient to use local functions to place all the functions required by bvp4c in a single file.

```
function mat4bvp

lambda = 15;
solinit = bvpinit(linspace(0,pi,10),@mat4init,lambda);
sol = bvp4c(@mat4ode,@mat4bc,solinit);

fprintf('The fourth eigenvalue is approximately %7.3f.\n',...
        sol.parameters)

xint = linspace(0,pi);
Sxint = deval(sol,xint);
plot(xint,Sxint(1,:))
axis([0 pi -1 1.1])
title('Eigenfunction of Mathieu''s equation.')
xlabel('x')
ylabel('solution y')
% -----
function dydx = mat4ode(x,y,lambda)
q = 5;
dydx = [ y(2)
        -(lambda - 2*q*cos(2*x))*y(1) ];
% -----
function res = mat4bc(ya,yb,lambda)
res = [ ya(2)
        yb(2)
```

```
ya(1)-1 ];  
% -----  
function yinit = mat4init(x)  
yinit = [ cos(4*x)  
         -4*sin(4*x) ];
```

The differential equation (converted to a first-order system) and the boundary conditions are coded as local functions `mat4ode` and `mat4bc`, respectively. Because unknown parameters are present, these functions must accept three input arguments, even though some of the arguments are not used.

The guess structure `solinit` is formed with `bvpinit`. An initial guess for the solution is supplied in the form of a function `mat4init`. We chose $y = \cos 4x$ because it satisfies the boundary conditions and has the correct qualitative behavior (the correct number of sign changes). In the call to `bvpinit`, the third argument (`lambda = 15`) provides an initial guess for the unknown parameter λ .

After the problem is solved with `bvp4c`, the field `sol.parameters` returns the value $\lambda = 17.097$, and the plot shows the eigenfunction associated with this eigenvalue.

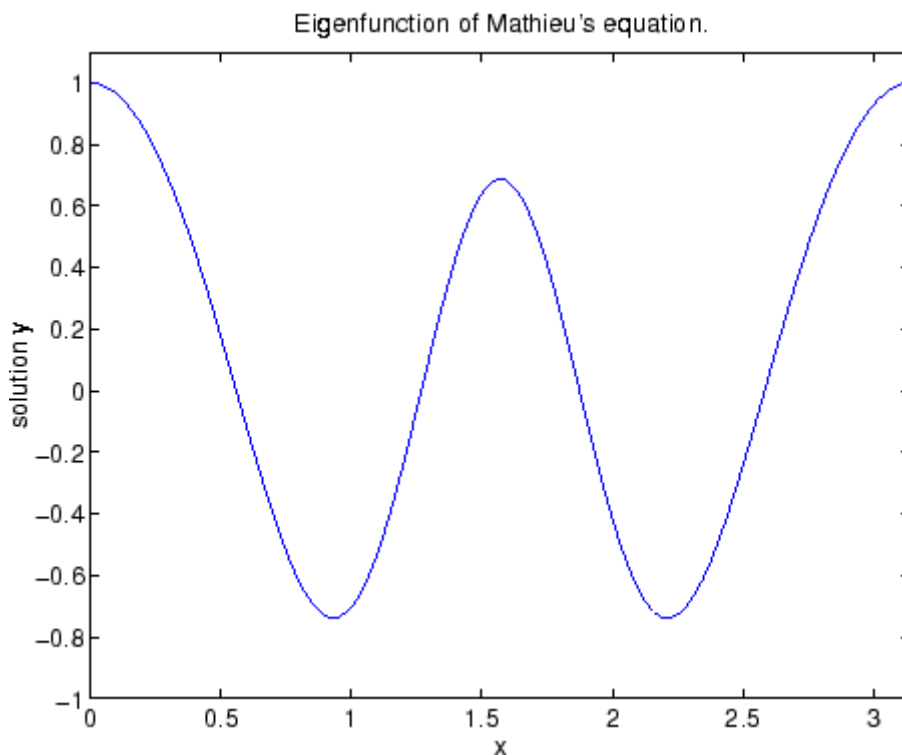

Algorithms

bvp4c is a finite difference code that implements the three-stage Lobatto IIIa formula. This is a collocation formula and the collocation polynomial provides a C^1 -continuous solution that is fourth-order accurate uniformly in $[a, b]$. Mesh selection and error control are based on the residual of the continuous solution.

References

[1] Shampine, L.F., M.W. Reichelt, and J. Kierzenka, "Solving Boundary Value Problems for Ordinary Differential Equations in MATLAB with bvp4c," available at http://www.mathworks.com/bvp_tutorial

See Also

@ | bvp5c | bvpget | bvpinit | bvpset | bvpextend | deval

bvp5c

Purpose Solve boundary value problems for ordinary differential equations

Syntax

```
sol = bvp5c(odefun,bcfun,solinit)
sol = bvp5c(odefun,bcfun,solinit,options)
solinit = bvpinit(x, yinit, params)
```

Arguments

odefun	A function handle that evaluates the differential equations $f(x,y)$. It can have the form $dydx = \text{odefun}(x,y)$ $dydx = \text{odefun}(x,y,\text{parameters})$ For a scalar x and a column vector y , $\text{odefun}(x,y)$ must return a column vector, $dydx$, representing $f(x,y)$. parameters is a vector of unknown parameters.	
bcfun	A function handle that computes the residual in the boundary conditions. For two-point boundary value conditions of the form $bc(y(a),y(b))$, bcfun can have the form $\text{res} = \text{bcfun}(ya,yb)$ $\text{res} = \text{bcfun}(ya,yb,\text{parameters})$ where ya and yb are column vectors corresponding to $y(a)$ and $y(b)$. parameters is a vector of unknown parameters. The output res is a column vector.	
solinit	A structure containing the initial guess for a solution. You create solinit using the function bvpinit . solinit has the following fields.	
	x	Ordered nodes of the initial mesh. Boundary conditions are imposed at $a = \text{solinit}.x(1)$ and $b = \text{solinit}.x(\text{end})$.

	<code>y</code>	Initial guess for the solution such that <code>solinit.y(:,i)</code> is a guess for the solution at the node <code>solinit.x(i)</code> .
	<code>parameters</code>	Optional. A vector that provides an initial guess for unknown parameters.
		The structure can have any name, but the fields must be named <code>x</code> , <code>y</code> , and <code>parameters</code> . You can form <code>solinit</code> with the helper function <code>bvpinit</code> . See <code>bvpinit</code> for details.
<code>options</code>		Optional integration argument. A structure you create using the <code>bvpset</code> function. See <code>bvpset</code> for details.

Description

`sol = bvp5c(odefun,bcfun,solinit)` integrates a system of ordinary differential equations of the form

$$y' = f(x,y)$$

on the interval `[a,b]` subject to two-point boundary value conditions

$$bc(y(a),y(b)) = 0$$

`odefun` and `bcfun` are function handles. See the `function_handle` reference page for more information.

“Parameterizing Functions” explains how to provide additional parameters to the function `odefun`, as well as the boundary condition function `bcfun`, if necessary. You can use the function `bvpinit` to specify the boundary points, which are stored in the input argument `solinit`.

The `bvp5c` solver can also find unknown parameters p for problems of the form

$$y' = f(x,y,p)$$

$$0 = bc(y(a),y(b),p)$$

where p corresponds to parameters. You provide `bvp5c` an initial guess for any unknown parameters in `solinit.parameters`. The `bvp5c` solver returns the final values of these unknown parameters in `sol.parameters`.

`bvp5c` produces a solution that is continuous on $[a,b]$ and has a continuous first derivative there. Use the function `deval` and the output `sol` of `bvp5c` to evaluate the solution at specific points `xint` in the interval $[a,b]$.

```
sxint = deval(sol,xint)
```

The structure `sol` returned by `bvp5c` has the following fields:

<code>sol.x</code>	Mesh selected by <code>bvp5c</code>
<code>sol.y</code>	Approximation to $y(x)$ at the mesh points of <code>sol.x</code>
<code>sol.parameters</code>	Values returned by <code>bvp5c</code> for the unknown parameters, if any
<code>sol.solver</code>	' <code>bvp5c</code> '
<code>sol.stats</code>	Computational cost statistics (also displayed when the <code>stats</code> option is set with <code>bvpset</code>).

The structure `sol` can have any name, and `bvp5c` creates the fields `x`, `y`, `parameters`, and `solver`.

`sol = bvp5c(odefun,bcfun,solinit,options)` solves as above with default integration properties replaced by the values in `options`, a structure created with the `bvpset` function. See `bvpset` for details.

`solinit = bvpinit(x, yinit, params)` forms the initial guess `solinit` with the vector `params` of guesses for the unknown parameters.

Singular Boundary Value Problems

`bvp5c` solves a class of singular boundary value problems, including problems with unknown parameters p , of the form

$$y' = S \cdot y/x + f(x,y,p)$$

$$0 = bc(y(0),y(b),p)$$

The interval is required to be $[0, b]$ with $b > 0$. Often such problems arise when computing a smooth solution of ODEs that result from partial differential equations (PDEs) due to cylindrical or spherical symmetry. For singular problems, you specify the (constant) matrix S as the value of the 'SingularTerm' option of `bvpset`, and `odefun` evaluates only $f(x,y,p)$. The boundary conditions must be consistent with the necessary condition $S \cdot y(0) = 0$ and the initial guess should satisfy this condition.

Multipoint Boundary Value Problems

`bvp5c` can solve multipoint boundary value problems where $a = a_0 < a_1 < a_2 < \dots < a_n = b$ are boundary points in the interval $[a,b]$. The points a_1, a_2, \dots, a_{n-1} represent interfaces that divide $[a,b]$ into regions. `bvp5c` enumerates the regions from left to right (from a to b), with indices starting from 1. In region k , $[a_{k-1}, a_k]$, `bvp5c` evaluates the derivative as

$$yp = \text{odefun}(x,y,k)$$

In the boundary conditions function

$$\text{bcfun}(y_{\text{left}}, y_{\text{right}})$$

$y_{\text{left}}(:, k)$ is the solution at the left boundary of $[a_{k-1}, a_k]$. Similarly, $y_{\text{right}}(:, k)$ is the solution at the right boundary of region k . In particular,

$$y_{\text{left}}(:, 1) = y(a)$$

and

$$y_{\text{right}}(:, \text{end}) = y(b)$$

When you create an initial guess with

$$\text{solinit} = \text{bvpinit}(x_{\text{init}}, y_{\text{init}}),$$

use double entries in `xinit` for each interface point. See the reference page for `bvpinit` for more information.

If `yinit` is a function, `bvpinit` calls `y = yinit(x, k)` to get an initial guess for the solution at `x` in region `k`. In the solution structure `sol` returned by `bvp5c`, `sol.x` has double entries for each interface point. The corresponding columns of `sol.y` contain the left and right solution at the interface, respectively.

To see an example of that solves a three-point boundary value problem, type `threebvp` at the MATLAB command prompt.

Algorithms

`bvp5c` is a finite difference code that implements the four-stage Lobatto IIIa formula. This is a collocation formula and the collocation polynomial provides a C^1 -continuous solution that is fifth-order accurate uniformly in $[a, b]$. The formula is implemented as an implicit Runge-Kutta formula. `bvp5c` solves the algebraic equations directly; `bvp4c` uses analytical condensation. `bvp4c` handles unknown parameters directly; while `bvp5c` augments the system with trivial differential equations for unknown parameters.

References

[1] Shampine, L.F., M.W. Reichelt, and J. Kierzenka “Solving Boundary Value Problems for Ordinary Differential Equations in MATLAB with `bvp4c`” http://www.mathworks.com/bvp_tutorial. Note that this tutorial uses the `bvp4c` function, however in most cases the solvers can be used interchangeably.

See Also

@ | `bvp4c` | `bvpget` | `bvpinit` | `bvpset` | `bvpxtend` | `deval`

Purpose Extract properties from options structure created with `bvpset`

Syntax

```
val = bvpget(options,'name')  
val = bvpget(options,'name',default)
```

Description

`val = bvpget(options,'name')` extracts the value of the named property from the structure `options`, returning an empty matrix if the property value is not specified in `options`. It is sufficient to type only the leading characters that uniquely identify the property. Case is ignored for property names. `[]` is a valid `options` argument.

`val = bvpget(options,'name',default)` extracts the named property as above, but returns `val = default` if the named property is not specified in `options`. For example,

```
val = bvpget(options,'RelTol',1e-4);
```

returns `val = 1e-4` if the `RelTol` is not specified in `options`.

See Also `bvp4c` | `bvp5c` | `bvpinit` | `bvpset` | `deval`

bvpinit

Purpose Form initial guess for BVP solvers

Syntax

```
solinit = bvpinit(x,yinit)
solinit = bvpinit(x,yinit,parameters)
solinit = bvpinit(sol,[anew bnew])
solinit = bvpinit(sol,[anew bnew],parameters)
```

Description `solinit = bvpinit(x,yinit)` forms the initial guess for a boundary value problem solver.

`x` is a vector that specifies an initial mesh. If you want to solve the BVP on $[a,b]$, then specify `x(1)` as a and `x(end)` as b . The solver adapts this mesh to the solution, so a guess like `xb=n linspace(a,b,10)` often suffices. However, in difficult cases, you should place mesh points where the solution changes rapidly. The entries of `x` must be in

- Increasing order if $a < b$
- Decreasing order if $a > b$

For two-point boundary value problems, the entries of `x` must be distinct. That is, if $a < b$, the entries must satisfy `x(1) < x(2) < ... < x(end)`. If $a > b$, the entries must satisfy `x(1) > x(2) > ... > x(end)`

For multipoint boundary value problem, you can specify the points in $[a,b]$ at which the boundary conditions apply, other than the endpoints a and b , by repeating their entries in `x`. For example, if you set

```
x = [0, 0.5, 1, 1, 1.5, 2];
```

the boundary conditions apply at three points: the endpoints 0 and 2, and the repeated entry 1. In general, repeated entries represent boundary points between regions in $[a,b]$. In the preceding example, the repeated entry 1 divides the interval $[0,2]$ into two regions: $[0,1]$ and $[1,2]$.

`yinit` is a guess for the solution. It can be either a vector, or a function:

- Vector – For each component of the solution, `bvpinit` replicates the corresponding element of the vector as a constant guess across

all mesh points. That is, `yinit(i)` is a constant guess for the *i*th component `yinit(i,:)` of the solution at all the mesh points in `x`.

- **Function** – For a given mesh point, the guess function must return a vector whose elements are guesses for the corresponding components of the solution. The function must be of the form

```
y = guess(x)
```

where `x` is a mesh point and `y` is a vector whose length is the same as the number of components in the solution. For example, if the guess function is a function, `bvpinit` calls

```
y(:,j) = guess(x(j))
```

at each mesh point.

For multipoint boundary value problems, the guess function must be of the form

```
y = guess(x, k)
```

where `y` an initial guess for the solution at `x` in region `k`. The function must accept the input argument `k`, which is provided for flexibility in writing the guess function. However, the function is not required to use `k`.

`solinit = bvpinit(x,yinit,parameters)` indicates that the boundary value problem involves unknown parameters. Use the vector `parameters` to provide a guess for all unknown parameters.

`solinit` is a structure with the following fields. The structure can have any name, but the fields must be named `x`, `y`, and `parameters`.

<code>x</code>	Ordered nodes of the initial mesh.
<code>y</code>	Initial guess for the solution with <code>solinit.y(:,i)</code> a guess for the solution at the node <code>solinit.x(i)</code> .
<code>parameters</code>	Optional. A vector that provides an initial guess for unknown parameters.

bvpinit

`solinit = bvpinit(sol,[anew bnew])` forms an initial guess on the interval `[anew bnew]` from a solution `sol` on an interval `[a,b]`. The new interval must be larger than the previous one, so either `anew <= a < b <= bnew` or `anew >= a > b >= bnew`. The solution `sol` is extrapolated to the new interval. If `sol` contains parameters, they are copied to `solinit`.

`solinit = bvpinit(sol,[anew bnew],parameters)` forms `solinit` as described above, but uses `parameters` as a guess for unknown parameters in `solinit`.

See Also

@ | [bvp4c](#) | [bvp5c](#) | [bvpget](#) | [bvpset](#) | [bvpxtend](#) | [deval](#)

Purpose

Create or alter options structure of boundary value problem

Syntax

```
options = bvpset('name1',value1,'name2',value2,...)
options = bvpset(olddopts,'name1',value1,...)
options = bvpset(olddopts,newopts)
bvpset
```

Description

`options = bvpset('name1',value1,'name2',value2,...)` creates a structure `options` that you can supply to the boundary value problem solver `bvp4c`, in which the named properties have the specified values. Any unspecified properties retain their default values. For all properties, it is sufficient to type only the leading characters that uniquely identify the property. `bvpset` ignores case for property names.

`options = bvpset(olddopts,'name1',value1,...)` alters an existing options structure `olddopts`. This overwrites any values in `olddopts` that are specified using name/value pairs and returns the modified structure as the output argument.

`options = bvpset(olddopts,newopts)` combines an existing options structure `olddopts` with a new options structure `newopts`. Any values set in `newopts` overwrite the corresponding values in `olddopts`.

`bvpset` with no input arguments displays all property names and their possible values, indicating defaults with braces `{}`.

You can use the function `bvpget` to query the options structure for the value of a specific property.

BVP Properties

`bvpset` enables you to specify properties for the boundary value problem solver `bvp4c`. There are several categories of properties that you can set:

- “Error Tolerance Properties” on page 1-632
- “Vectorization” on page 1-633
- “Analytical Partial Derivatives” on page 1-634
- “Singular BVPs” on page 1-635
- “Mesh Size Property” on page 1-636

- “Solution Statistic Property” on page 1-637

Error Tolerance Properties

Because `bvp4c` uses a collocation formula, the numerical solution is based on a mesh of points at which the collocation equations are satisfied. Mesh selection and error control are based on the residual of this solution, such that the computed solution $S(x)$ is the exact solution of a perturbed problem $S'(x) = f(x, S(x)) + res(x)$. On each subinterval of the mesh, a norm of the residual in the i th component of the solution, $res(i)$, is estimated and is required to be less than or equal to a tolerance. This tolerance is a function of the relative and absolute tolerances, `RelTol` and `AbsTol`, defined by the user.

$$\left| \left(res(i) / \max(abs(f(i)), AbsTol(i) / RelTol) \right) \right| \leq RelTol$$

The following table describes the error tolerance properties.

BVP Error Tolerance Properties

Property	Value	Description
<code>RelTol</code>	Positive scalar {1e-3}	<p>A relative error tolerance that applies to all components of the residual vector. It is a measure of the residual relative to the size of $f(x,y)$. The default, 1e-3, corresponds to 0.1% accuracy.</p> <p>The computed solution $S(x)$ is the exact solution of $S'(x) = F(x, S(x)) + res(x)$. On each subinterval of the mesh, the residual $res(x)$ satisfies</p> $\left \left(res(i) / \max(abs(F(i)), AbsTol(i) / RelTol) \right) \right \leq RelTol$
<code>AbsTol</code>	Positive scalar or vector {1e-6}	<p>Absolute error tolerances that apply to the corresponding components of the residual vector. <code>AbsTol(i)</code> is a threshold below which the values of the corresponding components are unimportant. If a scalar value is specified, it applies to all components.</p>

Vectorization

The following table describes the BVP vectorization property. Vectorization of the ODE function used by `bvp4c` differs from the vectorization used by the ODE solvers:

- For `bvp4c`, the ODE function must be vectorized with respect to the first argument as well as the second one, so that `F([x1 x2 ...], [y1 y2 ...])` returns `[F(x1,y1) F(x2,y2)...]`.
- `bvp4c` benefits from vectorization even when analytical Jacobians are provided. For stiff ODE solvers, vectorization is ignored when analytical Jacobians are used.

Vectorization Properties

Property	Value	Description
Vectorized	on {off}	<p>Set on to inform <code>bvp4c</code> that you have coded the ODE function <code>F</code> so that <code>F([x1 x2 ...], [y1 y2 ...])</code> returns <code>[F(x1,y1) F(x2,y2) ...]</code>. That is, your ODE function can pass to the solver a whole array of column vectors at once. This enables the solver to reduce the number of function evaluations and may significantly reduce solution time.</p> <p>With the MATLAB array notation, it is typically an easy matter to vectorize an ODE function. In the <code>shockbvp</code> example shown previously, the <code>shockODE</code> function has been vectorized using colon notation into the subscripts and by using the array multiplication <code>(.*)</code> operator.</p> <pre>function dydx = shockODE(x,y,e)</pre>

Vectorization Properties (Continued)

Property	Value	Description
		<pre> pix = pi*x; dydx = [y(2,:)... -x/e.*y(2,)-pi^2*cos(pix)- pix/e.*sin(pix)]; </pre>

Analytical Partial Derivatives

By default, the `bvp4c` solver approximates all partial derivatives with finite differences. `bvp4c` can be more efficient if you provide analytical partial derivatives $\partial f/\partial y$ of the differential equations, and analytical partial derivatives, $\partial bc/\partial ya$ and $\partial bc/\partial yb$, of the boundary conditions. If the problem involves unknown parameters, you must also provide partial derivatives, $\partial f/\partial p$ and $\partial bc/\partial p$, with respect to the parameters.

The following table describes the analytical partial derivatives properties.

BVP Analytical Partial Derivative Properties

Property	Value	Description
FJacobian	Function handle	A function handle that computes the analytical partial derivatives of $f(x,y)$. When solving $y' = f(x,y)$, set this property to <code>@fjac</code> if <code>dfdy = fjac(x,y)</code> evaluates the Jacobian $\partial f/\partial y$. If the problem involves unknown parameters p , <code>[dfdy,dfdp] = fjac(x,y,p)</code> must also return the partial derivative $\partial f/\partial p$. For problems with constant partial derivatives, set

BVP Analytical Partial Derivative Properties (Continued)

Property	Value	Description
		this property to the value of <code>dfdy</code> or to a cell array <code>{dfdy,dfdp}</code> .
BCJacobian	Function handle	A function handle that computes the analytical partial derivatives of $bc(ya,yb)$. For boundary conditions $bc(ya,yb)$, set this property to <code>@bcjac</code> if <code>[dbcodya,dbcodyb] = bcjac(ya,yb)</code> evaluates the partial derivatives $\partial bc/\partial ya$, and $\partial bc/\partial yb$. If the problem involves unknown parameters p , <code>[dbcodya,dbcodyb,dbcdp] = bcjac(ya,yb,p)</code> must also return the partial derivative $\partial bc/\partial p$. For problems with constant partial derivatives, set this property to a cell array <code>{dbcodya,dbcodyb}</code> or <code>{dbcodya,dbcodyb,dbcdp}</code> .

Singular BVPs

`bvp4c` can solve singular problems of the form

$$y' = S \frac{y}{x} + f(x,y,p)$$

posed on the interval $[0,b]$ where $b > 0$. For such problems, specify the constant matrix S as the value of `SingularTerm`. For equations of this form, `odefun` evaluates only the $f(x,y,p)$ term, where p represents unknown parameters, if any.

Singular BVP Property

Property	Value	Description
SingularTerm	Constant matrix	Singular term of singular BVPs. Set to the constant matrix S for equations of the form $y' = S \frac{y}{x} + f(x, y, p)$ posed on the interval $[0, b]$ where $b > 0$.

Mesh Size Property

bvp4c solves a system of algebraic equations to determine the numerical solution to a BVP at each of the mesh points. The size of the algebraic system depends on the number of differential equations (n) and the number of mesh points in the current mesh (N). When the allowed number of mesh points is exhausted, the computation stops, bvp4c displays a warning message and returns the solution it found so far. This solution does not satisfy the error tolerance, but it may provide an excellent initial guess for computations restarted with relaxed error tolerances or an increased value of N_{Max} .

The following table describes the mesh size property.

BVP Mesh Size Property

Property	Value	Description
NMax	positive integer {floor(1000/n)}	Maximum number of mesh points allowed when solving the BVP, where n is the number of differential equations in the problem. The default value of NMax limits the size of the algebraic system to about 1000 equations. For systems of a few differential equations, the default value of NMax should be sufficient to obtain an accurate solution.

Solution Statistic Property

The Stats property lets you view solution statistics.

The following table describes the solution statistics property.

BVP Solution Statistic Property

Property	Value	Description
Stats	on {off}	Specifies whether statistics about the computations are displayed. If the stats property is on, after solving the problem, bvp4c displays: <ul style="list-style-type: none"> • The number of points in the mesh • The maximum residual of the solution • The number of times it called the differential equation function odefun to evaluate $f(x,y)$

BVP Solution Statistic Property (Continued)

Property	Value	Description
		<ul style="list-style-type: none">The number of times it called the boundary condition function <code>bcfun</code> to evaluate $bc(y(a),y(b))$

Examples

To create an options structure that changes the relative error tolerance of `bvp4c` from the default value of $1e-3$ to $1e-4$, enter

```
options = bvpset('RelTol',1e-4);
```

To recover the value of 'RelTol' from `options`, enter

```
bvpget(options, 'RelTol')
```

```
ans =
```

```
1.0000e-004
```

See Also

`function_handle` | `bvp4c` | `bvp5c` | `bvpget` | `bvpinit` | `deval`

Purpose Form guess structure for extending boundary value solutions

Syntax

```
solinit = bvpxtend(sol,xnew,ynew)
solinit = bvpxtend(sol,xnew,extrap)
solinit = bvpxtend(sol,xnew)
solinit = bvpxtend(sol,xnew,ynew,pnew)
solinit = bvpxtend(sol,xnew,extrap,pnew)
```

Description `solinit = bvpxtend(sol,xnew,ynew)` uses solution `sol` computed on `[a,b]` to form a solution guess for the interval extended to `xnew`. The extension point `xnew` must be outside the interval `[a,b]`, but on either side. The vector `ynew` provides an initial guess for the solution at `xnew`.

`solinit = bvpxtend(sol,xnew,extrap)` forms the guess at `xnew` by extrapolating the solution `sol`. `extrap` is a string that determines the extrapolation method. `extrap` has three possible values:

- 'constant' — `ynew` is a value nearer to end point of solution in `sol`.
- 'linear' — `ynew` is a value at `xnew` of linear interpolant to the value and slope at the nearer end point of solution in `sol`.
- 'solution' — `ynew` is the value of (cubic) solution in `sol` at `xnew`.

The value of `extrap` is case-insensitive and only the leading, unique portion needs to be specified.

`solinit = bvpxtend(sol,xnew)` uses the extrapolating solution where `extrap` is 'constant'. If there are unknown parameters, values present in `sol` are used as the initial guess for parameters in `solinit`.

`solinit = bvpxtend(sol,xnew,ynew,pnew)` specifies a different guess `pnew`. `pnew` can be used with extrapolation, using the syntax `solinit = bvpxtend(sol,xnew,extrap,pnew)`. To modify parameters without changing the interval, use `[]` as place holder for `xnew` and `ynew`.

See Also `bvp4c` | `bvp5c` | `bvpinit`

calendar

Purpose Calendar for specified month

Syntax
c = calendar
c = calendar(d)
c = calendar(y, m)

Description c = calendar returns a 6-by-7 matrix containing a calendar for the current month. The calendar runs Sunday (first column) to Saturday.
c = calendar(d), where d is a serial date number or a date string, returns a calendar for the specified month.
c = calendar(y, m), where y and m are integers, returns a calendar for the specified month of the specified year.

Examples The command
calendar(1957,10)

reveals that the Space Age began on a Friday (on October 4, 1957, when Sputnik 1 was launched).

```
                Oct 1957
   S      M      Tu      W      Th      F      S
   0      0      1      2      3      4      5
   6      7      8      9      10     11     12
  13     14     15     16     17     18     19
  20     21     22     23     24     25     26
  27     28     29     30     31      0      0
   0      0      0      0      0      0      0
```

See Also datenum

Purpose	Call function in shared library
Syntax	<code>[x1,...,xN] = calllib(libname,funcname,arg1,...,argN)</code>
Description	<code>[x1,...,xN] = calllib(libname,funcname,arg1,...,argN)</code> calls function, <code>funcname</code> , in library, <code>libname</code> , passing input arguments, <code>arg1,...,argN</code> , and returns output values obtained from <code>funcname</code> in <code>x1,...,xN</code> .
Input Arguments	<p>libname - Name of shared library string</p> <p>Name of shared library, specified as a string. If you call <code>loadlibrary</code> using the <code>alias</code> option, then you must use the alias name for the <code>libname</code> argument.</p> <p>Data Types char</p> <p>funcname - Name of function in library string</p> <p>Name of function in library, specified as a string.</p> <p>Data Types char</p> <p>arg1,...,argN - Input arguments any type</p> <p>Input arguments, 1 through N, required by <code>funcname</code> (if any), specified by any type. The argument type is specified by the <code>funcname</code> argument list.</p>
Output Arguments	<p>x1,...,xN - Output arguments any type</p> <p>Output arguments, 1 through N, from <code>funcname</code> (if any), returned as any type. The argument type is specified by the <code>funcname</code> argument list.</p>

Limitations

- Use with libraries that are loaded using the `loadlibrary` function.

Examples

Call `addStructByRef` Function

Load the library.

```
if ~libisloaded('shrlibsample')
    addpath(fullfile(matlabroot,'extern','examples','shrlib'))
    loadlibrary('shrlibsample')
end
```

Display function signature.

```
libfunctionsview shrlibsample
```

```
[double, c_structPtr] addStructByRef(c_structPtr)
```

The input argument is a pointer to a `c_struct` data type.

Create a MATLAB structure, `struct`:

```
struct.p1 = 4; struct.p2 = 7.3; struct.p3 = -290;
```

Call the function.

```
[res,st] = calllib('shrlibsample','addStructByRef',struct);
```

Display the results.

```
res
```

```
res =
    -279
```

Cleanup.

```
unloadlibrary shrlibsample
```

See Also

`loadlibrary` | `libfunctionsview`

Concepts

- Passing Arguments
- “MATLAB Crashes Calling Function in Shared Library”

callSoapService

Purpose Send SOAP message to endpoint

Syntax `response = callSoapService(endpoint,soapAction,message)`

Description `response = callSoapService(endpoint,soapAction,message)` sends message, a Java[®] document object model (DOM), to the soapAction service at endpoint. Create message using `createSoapMessage`, and extract results from response using `parseSoapResponse`.

Examples This example uses `callSoapService` in conjunction with other SOAP functions to retrieve information about books from a library database, specifically, the author's name for a given book title.

Note The example does not use an actual endpoint; therefore, you cannot run it. The example only illustrates how to use the SOAP functions.

```
% Create the message:
message = createSoapMessage(...
'urn:LibraryCatalog',...
'getAuthor',...
{'In the Fall'},...
{'nameToLookUp'},...
{'{http://www.w3.org/2001/XMLSchema}string'},...
'rpc');
%
% Send the message to the service and get the response:
response = callSoapService(...
'http://test/soap/services/LibraryCatalog',...
'urn:LibraryCatalog#getAuthor',...
message)
%
% Extract MATLAB data from the response
```

```
author = parseSoapResponse(response)
```

MATLAB returns:

```
author = Kate Alvin
```

where author is a char class (type).

See Also

[createClassFromWsd1](#) | [createSoapMessage](#) | [parseSoapResponse](#) | [urlread](#) | [xmlread](#)

How To

- “Access Web Services Using MATLAB SOAP Functions”

Purpose Move camera position and target

Syntax

```
camdolly(dx,dy,dz)
camdolly(dx,dy,dz,'targetmode')
camdolly(dx,dy,dz,'targetmode','coordsys')
camdolly(axes_handle,...)
```

Description `camdolly(dx,dy,dz)` moves the camera position and the camera target by the specified amounts `dx`, `dy`, and `dz`.

`camdolly(dx,dy,dz,'targetmode')` uses the `targetmode` argument to determine how the camera moves:

- `movetarget` (default) — Move both the camera and the target.
- `fixtarget` — Move only the camera.

`camdolly(dx,dy,dz,'targetmode','coordsys')` uses the `coordsys` argument to determine how MATLAB interprets `dx`, `dy`, and `dz`:

- `camera` (default) — Move in the coordinate system of the camera. `dx` moves left/right, `dy` moves down/up, and `dz` moves along the viewing axis. MATLAB normalizes the units to the scene.

For example, setting `dx` to 1 moves the camera to the right, which pushes the scene to the left edge of the box formed by the axes position rectangle. A negative value moves the scene in the other direction. Setting `dz` to 0.5 moves the camera to a position halfway between the camera position and the camera target.

- `pixels` — Interpret `dx` and `dy` as pixel offsets and ignore `dz`.
- `data` — Interpret `dx`, `dy`, and `dz` as offsets in axes data coordinates.

`camdolly(axes_handle,...)` operates on the axes identified by the first argument, `axes_handle`. When you do not specify an axes handle, `camdolly` operates on the current axes.

`camdolly` sets the axes `CameraPosition` and `CameraTarget` properties, which in turn sets the `CameraPositionMode` and `CameraTargetMode` properties to manual.

Examples

Move the camera along the x - and y -axes in a series of steps:

```
surf(peaks)
axis vis3d
t = 0:pi/20:2*pi;
dx = sin(t)/40;
dy = cos(t)/40;
for i = 1:length(t);
    camdolly(dx(i),dy(i),0)
    drawnow
end
```

See Also

[axes](#) | [campos](#) | [camproj](#) | [camtarget](#) | [camup](#) | [camva](#) | [Axes CameraPosition](#) property | [Axes CameraTarget](#) property | [Axes CameraUpVector](#) property | [Axes CameraViewAngle](#) property | [Axes Projection](#) property

How To

- “Camera Graphics Terminology”

cameratoolbar

Purpose Control camera toolbar programmatically

Syntax

```
cameratoolbar
cameratoolbar('NoReset')
cameratoolbar('SetMode',mode)
cameratoolbar('SetCoordSys',coordsys)
cameratoolbar('Show')
cameratoolbar('Hide')
cameratoolbar('Toggle')
cameratoolbar('ResetCameraAndSceneLight')
cameratoolbar('ResetCamera')
cameratoolbar('ResetSceneLight')
cameratoolbar('ResetTarget')
mode = cameratoolbar('GetMode')
paxis = cameratoolbar('GetCoordsys')
vis = cameratoolbar('GetVisible')
cameratoolbar(fig,...)
h = cameratoolbar
cameratoolbar('Close')
```

Description cameratoolbar creates a toolbar that enables interactive manipulation of the axes camera and light when you drag the mouse on the figure window. Several axes camera properties are set when the toolbar is initialized.

cameratoolbar('NoReset') creates the toolbar without setting any camera properties.

cameratoolbar('SetMode',mode) sets the toolbar mode (depressed button). mode can be 'orbit', 'orbitscenelight', 'pan', 'dollyhv', 'dollyfb', 'zoom', 'roll', 'nomode'. For descriptions of the various modes, see “Camera Toolbar”. You can also set these modes using the toolbar, by clicking the respective buttons.

cameratoolbar('SetCoordSys',coordsys) sets the principal axis of the camera motion. coordsys can be: 'x', 'y', 'z', 'none'.

cameratoolbar('Show') shows the toolbar on the current figure.

`cameratoolbar('Hide')` hides the toolbar on the current figure.

`cameratoolbar('Toggle')` toggles the visibility of the toolbar.

`cameratoolbar('ResetCameraAndSceneLight')` resets the current camera and scenelight.

`cameratoolbar('ResetCamera')` resets the current camera.

`cameratoolbar('ResetSceneLight')` resets the current scenelight.

`cameratoolbar('ResetTarget')` resets the current camera target.

`mode = cameratoolbar('GetMode')` returns the current mode.

`paxis = cameratoolbar('GetCoordsys')` returns the current principal axis.

`vis = cameratoolbar('GetVisible')` returns the visibility of the toolbar (1 if visible, 0 if not visible).

`cameratoolbar(fig, ...)` specifies the figure to operate on by passing the figure handle as the first argument.

`h = cameratoolbar` returns the handle to the toolbar.

`cameratoolbar('Close')` removes the toolbar from the current figure.

In general, the use of OpenGL hardware improves rendering performance.

Alternatives

Display the toolbar by selecting **Camera Toolbar** from the figure window's **View** menu.

See Also

`rotate3d` | `zoom`

How To

- “Camera Toolbar”

camlight

Purpose Create or move light object in camera coordinates

Syntax

```
camlight('headlight')
camlight('right')
camlight('left')
camlight
camlight(az,e1)
camlight(...,'style')
camlight(light_handle,...)
light_handle = camlight(...)
```

Description

`camlight('headlight')` creates a light at the camera position.

`camlight('right')` creates a light right and up from camera.

`camlight('left')` creates a light left and up from camera.

`camlight` with no arguments is the same as `camlight('right')`.

`camlight(az,e1)` creates a light at the specified azimuth (`az`) and elevation (`e1`) with respect to the camera position. The camera target is the center of rotation and `az` and `e1` are in degrees.

`camlight(...,'style')` defines the style argument using one of two values:

- `local` (default) — The light is a point source that radiates from the location in all directions.
- `infinite` — The light shines in parallel rays.

`camlight(light_handle,...)` uses the light specified in `light_handle`.

`light_handle = camlight(...)` returns the light object handle.

`camlight` sets the light object `Position` and `Style` properties. A light created with `camlight` does not track the camera. In order for the light to stay in a constant position relative to the camera, call `camlight` whenever you move the camera.

Examples

Create a light positioned to the left of the camera and then reposition the light each time the camera moves:

```
surf(peaks)
axis vis3d
h = camlight('left');
for i = 1:20;
    camorbit(10,0)
    camlight(h,'left')
    drawnow;
end
```

See Also

[lightangle](#) | [light](#)

How To

- “Lighting Overview”

camlookat

Purpose Position camera to view object or group of objects

Syntax `camlookat(object_handles)`
`camlookat(axes_handle)`
`camlookat`

Description `camlookat(object_handles)` views the objects identified in the vector `object_handles`. The vector can contain the handles of axes children.

`camlookat(axes_handle)` views the objects that are children of the axes identified by `axes_handle`.

`camlookat` views the objects that are in the current axes by moving the camera position and camera target while preserving the relative view direction and camera view angle. The viewed object (or objects) roughly fill the axes position rectangle. To change the view, `camlookat` sets the axes `CameraPosition` and `CameraTarget` properties.

Examples Create three spheres at different locations and then progressively position the camera so that the scene composes around each sphere individually:

```
% Create three spheres using the sphere function:  
[x y z] = sphere;  
s1 = surf(x,y,z);  
hold on  
s2 = surf(x+3,y,z+3);  
s3 = surf(x,y,z+6);  
% Set the data aspect ratio using daspect:  
daspect([1 1 1])  
% Set the view:  
view(30,10)  
% Set the projection type using camproj:  
camproj perspective  
% Compose the scene around the current axes  
camlookat(gca)  
pause(2)  
% Compose the scene around sphere s1
```

```
camlookat(s1)
pause(2)
% Compose the scene around sphere s2
camlookat(s2)
pause(2)
% Compose the scene around sphere s3
camlookat(s3)
pause(2)
camlookat(gca)
```

See Also

campos | camtarget

How To

- “Camera Graphics Terminology”

camorbit

Purpose

Rotate camera position around camera target

Syntax

```
camorbit(dtheta,dphi)
camorbit(dtheta,dphi,'coordsys')
camorbit(dtheta,dphi,'coordsys','direction')
camorbit(axes_handle,...)
```

Description

`camorbit(dtheta,dphi)` rotates the camera position around the camera target by the amounts specified in `dtheta` and `dphi` (both in degrees). `dtheta` is the horizontal rotation and `dphi` is the vertical rotation.

`camorbit(dtheta,dphi,'coordsys')` rotates the camera position around the camera target, using the `coordsys` argument to determine the center of rotation. `coordsys` can take on two values:

- `data` (default) — Rotate the camera around an axis defined by the camera target and the `direction` (default is the positive `z` direction).
- `camera` — Rotate the camera about the point defined by the camera target.

`camorbit(dtheta,dphi,'coordsys','direction')` defines the axis of rotation for the `data` coordinate system using the `direction` argument in conjunction with the camera target. Specify `direction` as a three-element vector containing the `x`-, `y`-, and `z`-components of the direction or one of the characters, `x`, `y`, or `z`, to indicate `[1 0 0]`, `[0 1 0]`, or `[0 0 1]` respectively.

`camorbit(axes_handle,...)` operates on the axes identified by the first argument, `axes_handle`. When you do not specify an axes handle, `camorbit` operates on the current axes.

The behavior of `camorbit` differs from the `rotate3d` function in that while the `rotate3d` tool modifies the `View` property of the axes, the `camorbit` function fixes the aspect ratio and modifies the `CameraTarget`, `CameraPosition` and `CameraUpVector` properties of the axes. See `Axes Properties` for more information.

Examples

Rotate the camera horizontally about a line defined by the camera target point and a direction that is parallel to the y -axis. Visualize this rotation as a cone formed with the camera target at the apex and the camera position forming the base:

```
surf(peaks)
axis vis3d
for i=1:36
    camorbit(10,0,'data',[0 1 0])
    drawnow
end
```

Rotate in the camera coordinate system to orbit the camera around the axes along a circle while keeping the center of a circle at the camera target:

```
surf(peaks)
axis vis3d
for i=1:36
    camorbit(10,0,'camera')
    drawnow
end
```

Alternatives

Enable 3-D rotation from the figure **Tools** menu or the figure toolbar.

See Also

[axes](#) | [axis](#) | [camdolly](#) | [campan](#) | [camzoom](#) | [camroll](#)

How To

- “Camera Graphics Terminology”

campan

Purpose Rotate camera target around camera position

Syntax

```
campan(dtheta,dphi)
campan(dtheta,dphi,coordsys)
campan(dtheta,dphi,coordsys,direction)
campan(axes_handle,...)
```

Description `campan(dtheta,dphi)` rotates the camera target of the current axes around the camera position by the amounts specified in `dtheta` and `dphi` (both in degrees). `dtheta` is the horizontal rotation and `dphi` is the vertical rotation.

`campan(dtheta,dphi,coordsys)` determine the center of rotation using the `coordsys` argument. It can take on two values:

- 'data' (default) — Rotate the camera target around an axis defined by the camera position and the `direction` (default is the positive `z` direction)
- 'camera' — Rotate the camera about the point defined by the camera target.

`campan(dtheta,dphi,coordsys,direction)` defines the axis of rotation for the data coordinate system using the `direction` argument with the camera position. Specify `direction` as a three-element vector containing the `x`-, `y`-, and `z`-components of the direction or one of the characters, 'x', 'y', or 'z', to indicate [1 0 0], [0 1 0], or [0 0 1] respectively.

`campan(axes_handle,...)` operates on the axes identified by the first argument, `axes_handle`. When you do not specify an axes handle, `campan` operates on the current axes.

Examples Move the camera target to pan the object in a circular motion.

```
sphere;
axis vis3d
hPan = sin(-pi:1:pi);
vPan = cos(-pi:1:pi);
```

```
for k=1:length(hPan)
    campan(hPan(k),vPan(k))
    drawnow
    pause(.1)
end
```

See Also

[axes](#) | [camdolly](#) | [camorbit](#) | [camtarget](#) | [camzoom](#) | [camroll](#)

How To

- “Camera Graphics Terminology”

campos

Purpose Set or query camera position

Syntax

```
campos
campos([camera_position])
campos('mode')
campos('auto')
campos('manual')
campos(axes_handle,...)
```

Description

`campos` returns the camera position in the current axes.

`campos([camera_position])` sets the position of the camera in the current axes to the specified value. Specify the position as a three-element vector containing the x -, y -, and z -coordinates of the desired location in the data units of the axes.

`campos('mode')` returns the value of the camera position mode, which can be either `auto` (the default) or `manual`.

`campos('auto')` sets the camera position mode to `auto`.

`campos('manual')` sets the camera position mode to `manual`.

`campos(axes_handle,...)` performs the set or query on the axes identified by the first argument, `axes_handle`. When you do not specify an axes handle, `campos` operates on the current axes.

`campos` sets or queries values of the axes `CameraPosition` and `CameraPositionMode` properties. The camera position is the point in the Cartesian coordinate system of the axes from which you view the scene.

Examples Move the camera along the x -axis in a series of steps:

```
surf(peaks)
axis vis3d off
for x = -200:5:200
    campos([x,5,10])
    drawnow
end
```

See Also

[axis](#) | [camproj](#) | [camtarget](#) | [camup](#) | [camva](#) | [Axes: CameraPosition](#)
| [Axes: CameraTarget](#) | [Axes: CameraUpVector](#) | [Axes: CameraViewAngle](#) | [Axes: Projection](#)

How To

- “Camera Graphics Terminology”

camproj

Purpose Set or query projection type

Syntax
`camproj`
`camproj('projection_type')`
`camproj(axes_handle,...)`

Description `camproj` returns the projection type setting in the current axes. The projection type determines whether MATLAB 3-D views use a perspective or orthographic projection.

`camproj('projection_type')` sets the projection type in the current axes to the specified value. Possible values for *projection_type* are orthographic and perspective.

`camproj(axes_handle,...)` performs the set or query on the axes identified by the first argument, `axes_handle`. When you do not specify an axes handle, `camproj` operates on the current axes.

`camproj` sets or queries values of the axes object `Projection` property.

Examples Compare the different `camproj` settings using `subplot`:

```
subplot(1,2,1); surf(membrane); camproj('perspective')
subplot(1,2,2); surf(membrane); camproj('orthographic')
```

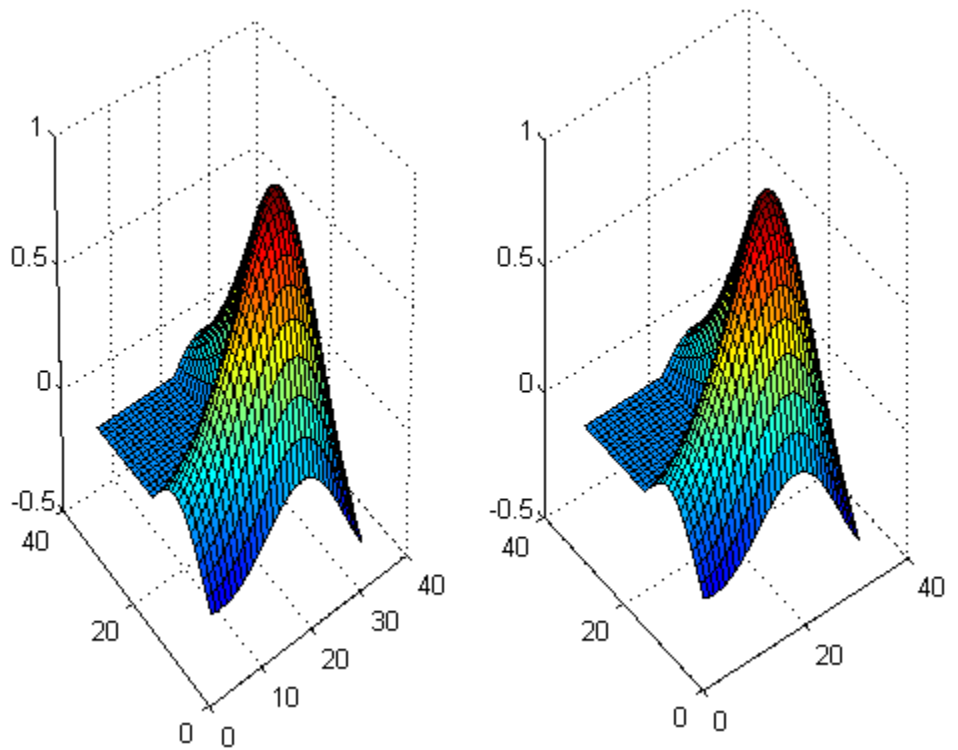

See Also

[axis](#) | [campos](#) | [camtargt](#) | [camup](#) | [camva](#) | [Axes: CameraPosition](#)
| [Axes: CameraTarget](#) | [Axes: CameraUpVector](#) | [Axes:](#)
[CameraViewAngle](#) | [Axes: Projection](#)

How To

- “Camera Graphics Terminology”

camroll

Purpose Rotate camera about view axis

Syntax `camroll(dtheta)`
`camroll(axes_handle,dtheta)`

Description `camroll(dtheta)` rotates the camera around the camera viewing axis by the amounts specified in `dtheta` (in degrees). The viewing axis is the line passing through the camera position and the camera target.

`camroll(axes_handle,dtheta)` operates on the axes identified by the first argument, `axes_handle`. When you do not specify an axes handle, `camroll` operates on the current axes.

`camroll` sets the axes `CameraUpVector` property and also sets the `CameraUpVectorMode` property to `manual`.

Examples Rotate the camera around the viewing axis:

```
surf(peaks)
axis vis3d
for i=1:36
    camroll(10)
    drawnow
end
```

See Also `axes` | `axis` | `camdolly` | `camorbit` | `camzoom` | `campan`

How To • “Camera Graphics Terminology”

Purpose Set or query location of camera target

Syntax

```
camtarget
camtarget([camera_target])
camtarget('mode')
camtarget('auto')
camtarget('manual')
camtarget('manual')
camtarget(axes_handle,...)
```

Description `camtarget` returns the location of the camera target in the current axes. The camera target is the location in the axes that the camera points to. The camera remains oriented toward this point regardless of its position.

`camtarget([camera_target])` sets the camera target in the current axes to the specified value. Specify the target as a three-element vector containing the x -, y -, and z -coordinates of the desired location in the data units of the axes.

`camtarget('mode')` returns the value of the camera target mode, which can be either `auto` (default) or `manual`.

`camtarget('auto')` sets the camera target mode to `auto`. When the camera target mode is `auto`, the camera target is the center of the axes plot box.

`camtarget('manual')` sets the camera target mode to `manual`.

`camtarget(axes_handle,...)` performs the set or query on the axes identified by `axes_handle`. When you do not specify an axes handle, `camtarget` operates on the current axes.

`camtarget` sets or queries values of the axes object `CameraTarget` and `CameraTargetMode` properties.

Examples Move the camera position and the camera target along the x -axis in a series of steps:

```
surf(peaks);
axis vis3d
```

camtarget

```
xp = linspace(-150,40,50);
xt = linspace(25,50,50);
for i=1:50
    campos([xp(i),25,5]);
    camtarget([xt(i),30,0])
    drawnow
end
```

See Also

[axis](#) | [campos](#) | [camup](#) | [camva](#) | [Axes: CameraPosition](#) | [Axes: CameraTarget](#) | [Axes: CameraUpVector](#) | [Axes: CameraViewAngle](#) | [Axes: Projection](#)

How To

- “Camera Graphics Terminology”

Purpose Set or query camera up vector

Syntax

```
camup
camup([up_vector])
camup('mode')
camup('auto')
camup('manual')
camup(axes_handle,...)
```

Description `camup` returns the camera up vector setting in the current axes. The camera up vector specifies the direction that is oriented up in the scene.

`camup([up_vector])` sets the up vector in the current axes to the specified value. Specify the up vector as x , y , and z components.

`camup('mode')` returns the current value of the camera up vector mode, which can be either `auto` (default) or `manual`.

`camup('auto')` sets the camera up vector mode to `auto`. In `auto` mode, $[0\ 1\ 0]$ is the up vector of for 2-D views. This means the y -axis points up. For 3-D views, the up vector is $[0\ 0\ 1]$, meaning the z -axis points up.

`camup('manual')` sets the camera up vector mode to `manual`. In `manual` mode, the value of the camera up vector does not change unless you set it.

`camup(axes_handle,...)` performs the set or query on the axes identified by the first argument, `axes_handle`. When you do not specify an axes handle, `camup` operates on the current axes.

Examples Set the x -axis to be the up axis:

```
surf(peaks)
camup([1 0 0]);
```

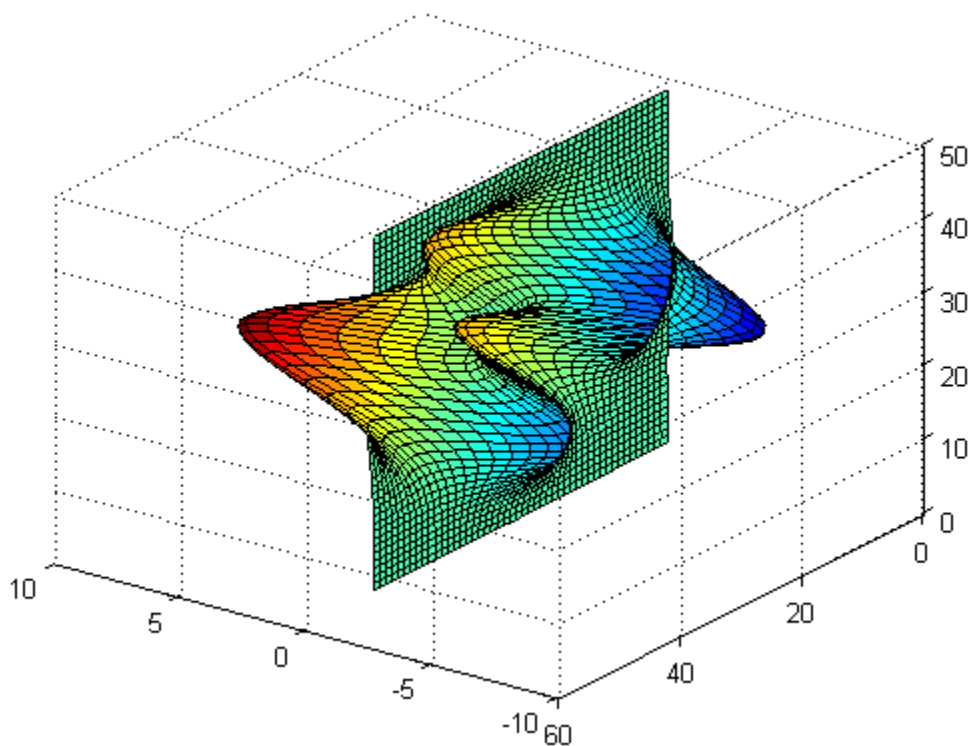

See Also

[axis](#) | [campos](#) | [camup](#) | [camtarg](#) | [Axes: CameraPosition](#) | [Axes: CameraTarget](#) | [Axes: CameraUpVector](#) | [Axes: CameraViewAngle](#) | [Axes: Projection](#)

How To

- “Camera Graphics Terminology”

Purpose Set or query camera view angle

Syntax

```
camva
camva(view_angle)
camva('mode')
camva('auto')
camva('manual')
camva(axes_handle,...)
```

Description `camva` returns the camera view angle setting in the current axes. The camera view angle determines the field of view of the camera. Larger angles produce a smaller view of the scene. Implement zooming by changing the camera view angle.

`camva(view_angle)` sets the view angle in the current axes to the specified value. Specify the view angle in degrees.

`camva('mode')` returns the current value of the camera view angle mode, which can be either `auto` (the default) or `manual`.

`camva('auto')` sets the camera view angle mode to `auto`.

`camva('manual')` sets the camera view angle mode to `manual`.

`camva(axes_handle,...)` performs the set or query on the axes identified by the first argument, `axes_handle`. When you do not specify an axes handle, `camva` operates on the current axes.

Tips The `camva` function sets or queries values of the axes object `CameraViewAngle` and `CameraViewAngleMode` properties.

When the camera view angle mode is `auto`, the camera view angle adjusts so that the scene fills the available space in the window. If you move the camera to a different position, the camera view angle changes to maintain a view of the scene that fills the available area in the window.

Setting a camera view angle or setting the camera view angle to `manual` disables the MATLAB stretch-to-fill feature (stretching of the axes

to fit the window). This means setting the camera view angle to its current value,

```
camva(camva)
```

can cause a change in the way the graph looks. See axes for more information.

Examples

Create two pushbuttons, one that zooms in and another that zooms out:

```
% Set the range checking in the callback statements to keep
% the values for the camera view angle in the range greater
% than zero and less than 180.
uicontrol('Style','pushbutton',...
    'String','Zoom In',...
    'Position',[20 20 60 20],...
    'Callback','if camva <= 1;return;else;camva(camva-1);end');
uicontrol('Style','pushbutton',...
    'String','Zoom Out',...
    'Position',[100 20 60 20],...
    'Callback',...
    'if camva >= 179;return;else;camva(camva+1);end');
% Now create a graph to zoom in and out on:
surf(peaks);
```

See Also

[axis](#) | [campos](#) | [camup](#) | [camtarget](#) | [Axes: CameraPosition](#) | [Axes: CameraTarget](#) | [Axes: CameraUpVector](#) | [Axes: CameraViewAngle](#) | [Axes: Projection](#)

How To

- “Camera Graphics Terminology”

Purpose	Zoom in and out on scene
Syntax	<code>camzoom(zoom_factor)</code> <code>camzoom(axes_handle,...)</code>
Description	<p><code>camzoom(zoom_factor)</code> zooms in or out on the scene depending on the value specified by <code>zoom_factor</code>. If <code>zoom_factor</code> is greater than 1, the scene appears larger; if <code>zoom_factor</code> is greater than zero and less than 1, the scene appears smaller.</p> <p><code>camzoom(axes_handle,...)</code> operates on the axes identified by the first argument, <code>axes_handle</code>. When you do not specify an axes handle, <code>camzoom</code> operates on the current axes.</p>
Tips	<p><code>camzoom</code> sets the axes <code>CameraViewAngle</code> property, which in turn causes the <code>CameraViewAngleMode</code> property to be set to <code>manual</code>. Note that setting the <code>CameraViewAngle</code> property disables the MATLAB stretch-to-fill feature (stretching of the axes to fit the window). This may result in a change to the aspect ratio of your graph. See the <code>axes</code> function for more information on this behavior.</p>
See Also	<code>axes</code> <code>camdolly</code> <code>camorbit</code> <code>campan</code> <code>camroll</code> <code>camva</code>
How To	<ul style="list-style-type: none">• “Camera Graphics Terminology”

TriRep.cartToBary

Purpose (Will be removed) Convert point coordinates from cartesian to barycentric

Note `cartToBary(TriRep)` will be removed in a future release. Use `cartesianToBarycentric(triangulation)` instead.

`TriRep` will be removed in a future release. Use `triangulation` instead.

Syntax `B = cartToBary(TR, SI, XC)`

Description `B = cartToBary(TR, SI, XC)` returns the barycentric coordinates of each point in `XC` with respect to its associated simplex `SI`.

Input Arguments

`TR` Triangulation representation.

`SI` Column vector of simplex indices that index into the triangulation matrix `TR.Triangulation`.

`XC` Matrix that represents the Cartesian coordinates of the points to be converted. `XC` is of size `m-by-n`, where `m` is of `length(SI)`, the number of points to convert, and `n` is the dimension of the space where the triangulation resides.

Output Arguments

`B` Matrix of dimension `m-by-k` where `k` is the number of vertices per simplex.

Definitions A simplex is a triangle/tetrahedron or higher dimensional equivalent.

Examples

Compute the Delaunay triangulation of a set of points.

```
x = [0 4 8 12 0 4 8 12]';
```



```
y = [0 0 0 0 8 8 8 8]';  
dt = DelaunayTri(x,y)
```

Compute the barycentric coordinates of the incenters.

```
cc = incenters(dt);  
tri = dt(:,:);
```

Plot the original triangulation and reference points.

```
figure  
subplot(1,2,1);  
triplot(dt); hold on;  
plot(cc(:,1), cc(:,2), '*r');  
hold off;  
axis equal;
```

Stretch the triangulation and compute the mapped locations of the incenters on the deformed triangulation.

```
b = cartToBary(dt,[1:length(tri)]',cc);  
y = [0 0 0 0 16 16 16 16]';  
tr = TriRep(tri,x,y)  
xc = baryToCart(tr, [1:length(tri)]', b);
```

Plot the deformed triangulation and mapped locations of the reference points.

```
subplot(1,2,2);  
triplot(tr);  
hold on;  
plot(xc(:,1), xc(:,2), '*r');  
hold off;  
axis equal;
```

TriRep.cartToBary

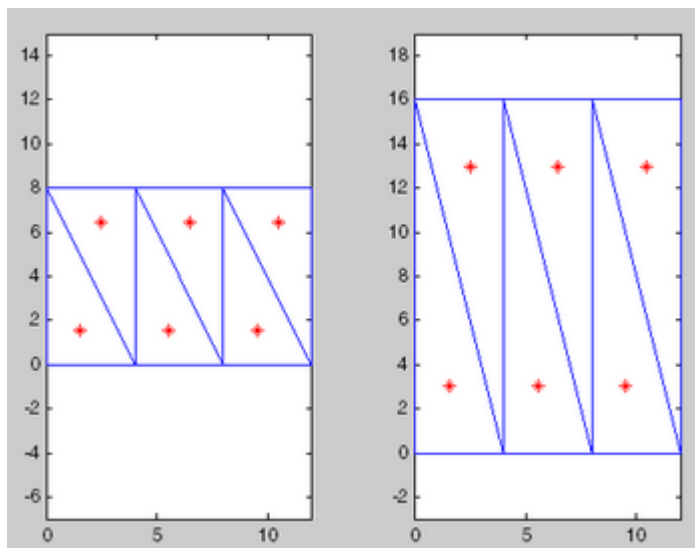

See Also

[barycentricToCartesian](#) | [pointLocation](#) | [delaunayTriangulation](#)
| [triangulation](#)

Purpose Transform Cartesian coordinates to polar or cylindrical

Syntax `[THETA,RHO,Z] = cart2pol(X,Y,Z)`
`[THETA,RHO] = cart2pol(X,Y)`

Description `[THETA,RHO,Z] = cart2pol(X,Y,Z)` transforms three-dimensional Cartesian coordinates stored in corresponding elements of arrays X, Y, and Z, into cylindrical coordinates. THETA is a counterclockwise angular displacement in radians from the positive x-axis, RHO is the distance from the origin to a point in the x-y plane, and Z is the height above the x-y plane. Arrays X, Y, and Z must be the same size (or any can be scalar).

`[THETA,RHO] = cart2pol(X,Y)` transforms two-dimensional Cartesian coordinates stored in corresponding elements of arrays X and Y into polar coordinates.

Algorithms The mapping from two-dimensional Cartesian coordinates to polar coordinates, and from three-dimensional Cartesian coordinates to cylindrical coordinates is

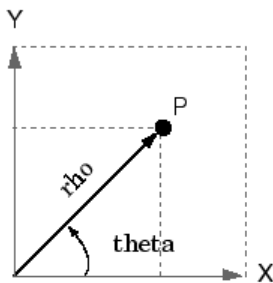

Two-Dimensional Mapping
 $\text{theta} = \text{atan2}(y,x)$
 $\text{rho} = \sqrt{x.^2 + y.^2}$

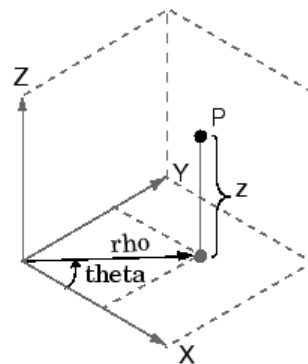

Three-Dimensional Mapping
 $\text{theta} = \text{atan2}(y,x)$
 $\text{rho} = \sqrt{x.^2 + y.^2}$
 $Z = Z$

cart2pol

See Also

[cart2sph](#) | [pol2cart](#) | [sph2cart](#)

Purpose Transform Cartesian coordinates to spherical

Syntax `[azimuth,elevation,r] = cart2sph(X,Y,Z)`

Description `[azimuth,elevation,r] = cart2sph(X,Y,Z)` transforms Cartesian coordinates stored in corresponding elements of arrays X, Y, and Z into spherical coordinates. `azimuth` and `elevation` are angular displacements in radians. `azimuth` is the counterclockwise angle in the *x-y* plane measured from the positive *x*-axis. `elevation` is the elevation angle from the *x-y* plane. `r` is the distance from the origin to a point.

Arrays X, Y, and Z must be the same size (or any of them can be scalar).

Algorithms The mapping from three-dimensional Cartesian coordinates to spherical coordinates is

```
azimuth = atan2(y,x)
elevation = atan2(z,sqrt(x.^2 + y.^2))
r = sqrt(x.^2 + y.^2 + z.^2)
```

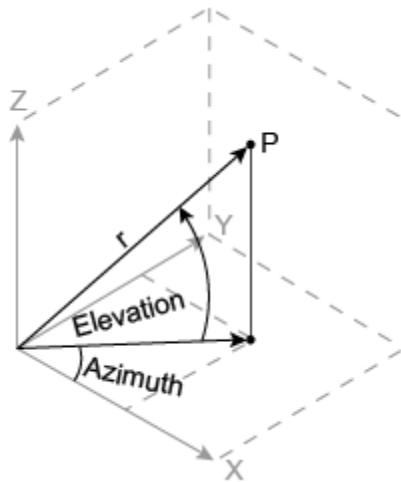

cart2sph

The notation for spherical coordinates is not standard. For the `cart2sph` function, `elevation` is measured from the x - y plane. Notice that if `elevation = 0`, the point is in the x - y plane. If `elevation = pi/2`, then the point is on the positive z -axis.

See Also

`cart2pol` | `pol2cart` | `sph2cart`

Purpose

Cast variable to different data type

Syntax

```
B = cast(A,newclass)
B = cast(A,'like',p)
```

Description

`B = cast(A,newclass)` converts `A` to class `newclass`, where `newclass` is the name of a built-in data type compatible with `A`. The `cast` function truncates any values in `A` that are too large to map into `newclass`.

`B = cast(A,'like',p)` converts `A` to the same data type and sparsity as the variable `p`. If `A` and `p` are both real, then `B` is also real. Otherwise, `B` is complex.

Examples**Convert Numeric Data Type**

Convert an `int8` value to `uint8`.

Define a scalar 8-bit integer.

```
a = int8(5);
```

Convert `a` to an unsigned 8-bit integer.

```
b = cast(a,'uint8');
class(b)
```

```
ans =
uint8
```

Match Data Type and Complex Nature of p

Define a single precision vector `p` that is complex valued.

```
p = single([1+i 2]);
```

Define a 2-by-3 matrix of ones.

```
A = ones(2,3);
```

Convert `A` to the same data type and complexity (real or complex) as `p`.

cast

```
B = cast(A, 'like', p)
```

```
B =
```

```
    1.0000 + 0.0000i    1.0000 + 0.0000i    1.0000 + 0.0000i  
    1.0000 + 0.0000i    1.0000 + 0.0000i    1.0000 + 0.0000i
```

Check the class of B.

```
class(B)
```

```
ans =
```

```
single
```

See Also

[class](#) | [typecast](#)

Concepts

- “Class Support for Array-Creation Functions”

Purpose

Concatenate arrays along specified dimension

Syntax

```
C = cat(dim, A, B)
C = cat(dim, A1, A2, A3, A4, ...)
```

Description

`C = cat(dim, A, B)` concatenates the arrays `A` and `B` along array the dimension specified by `dim`. The `dim` argument must be a real, positive, integer value.

`C = cat(dim, A1, A2, A3, A4, ...)` concatenates all the input arrays (`A1`, `A2`, `A3`, `A4`, and so on) along array dimension `dim`.

For nonempty arrays, `cat(2, A, B)` is the same as `[A, B]`, and `cat(1, A, B)` is the same as `[A; B]`.

If your input arrays are tables, `dim` must be either 1 or 2. `cat` then concatenates by calling `horzcat` or `vertcat` respectively.

Tips

When used with comma-separated list syntax, `cat(dim, C{:})` or `cat(dim, C.field)` is a convenient way to concatenate a cell or structure array containing numeric matrices into a single matrix.

You can concatenate categorical arrays with cell arrays of strings. For more information, see “Combine Categorical Arrays”.

If all the input arrays are ordinal categorical arrays, they must have the same sets of categories including their order. For more information, see “Ordinal Categorical Arrays”.

For information on combining unlike integer types, integers with nonintegers, cell arrays with non-cell arrays, or empty matrices with other elements, see “Valid Combinations of Unlike Classes”

Examples

Given

```
A =           B =
     1     2           5     6
     3     4           7     8
```

cat

concatenating along different dimensions produces

1	2
3	4
5	6
7	8

C = cat(1,A,B)

1	2	5	6
3	4	7	8

C = cat(2,A,B)

1	2
3	4

5	6
7	8

C = cat(3,A,B)

The commands

```
A = magic(3); B = pascal(3);  
C = cat(4, A, B);
```

produce a 3-by-3-by-1-by-2 array.

See Also

`vertcat` | `horzcat` | `strcat` | `char` | `num2cell` | `reshape` | `squeeze`
| `strjoin` | `shiftdim` | `special character`

Purpose

Create categorical array

Syntax

```
B = categorical(A)
B = categorical(A,valueSet)
B = categorical(A,valueSet,catnames)
B = categorical(A, __ ,Name,Value)
```

Description

`B = categorical(A)` creates a categorical array from the array, `A`. The categories of `B` are the sorted unique values from `A`.

For more information on creating and using categorical arrays, see “Categorical Arrays”.

`B = categorical(A,valueSet)` creates one category for each value in `valueSet`. The categories of `B` are in the same order as the values of `valueSet`.

You can use `valueSet` to include categories for values not present in `A`. Conversely, if `A` contains any values not present in `valueSet`, the corresponding elements of `B` are undefined.

`B = categorical(A,valueSet,catnames)` names the categories in `B` by matching the category values in `valueSet` with the names in `catnames`.

`B = categorical(A, __ ,Name,Value)` creates a categorical array with additional options specified by one or more `Name,Value` pair arguments. You can include any of the input arguments in previous syntaxes.

For example, you can specify that the categories have a mathematical ordering.

Input Arguments**A - Input array**

numeric array | logical array | categorical array | cell array of strings
| ...

Input array, specified as a numeric array, logical array, categorical array, or cell array of strings.

If **A** contains missing values, the corresponding element of **B** is `<undefined>`. Missing values are `NaN` for numeric arrays, the empty string (`' '`) for cell arrays of strings, and `<undefined>` for categorical arrays. **B** does not have a category for undefined values. To create an explicit category for missing or undefined values, you must include the desired category name in `catnames`, and `NaN`, the empty string, or `<undefined>` in `valueset`.

In addition to an array, **A** can be an object with the following class methods:

- `unique`
- `eq`

valueset - Values to define categories

`unique(A)` (default) | vector of unique values

Values to define categories, specified as a vector of unique values. The data type of `valueset` and the data type of **A** must be the same.

catnames - Category names

cell array of strings

Category names, specified as a cell array of strings. If you do not specify the `catnames` input argument, `categorical` uses the values in `valueset` as category names.

To merge multiple distinct values in **A** into a single category in **B**, include duplicate names corresponding to those values.

Name-Value Pair Arguments

Specify optional comma-separated pairs of `Name, Value` arguments. `Name` is the argument name and `Value` is the corresponding value. `Name` must appear inside single quotes (`' '`). You can specify several name and value pair arguments in any order as `Name1, Value1, ..., NameN, ValueN`.

Example: 'Ordinal', true specifies that the categories have a mathematical ordering

'Ordinal' - Mathematical ordering indicator

false (default) | true | 0 | 1

Mathematical ordering indicator, specified as the comma-separated pair consisting of 'Ordinal' and either false, true, 0, or 1.

false `categorical` creates a categorical array that is not ordinal. This is the default behavior.

The categories of **B** have no mathematical ordering. Therefore, you can only compare the values in **B** for equality.

true `categorical` creates an ordinal categorical array.

The categories of **B** have a mathematical ordering, such that the first category specified is the smallest and the last category is the largest. You can compare the values in **B** using relational operators, such as less than and greater than, in addition to comparing the values for equality.

'Protected' - Category protection indicator

false | true | 0 | 1

Category protection indicator specified as the comma-separated pair consisting of 'Protected' and either false, true, 0, or 1. The categories of ordinal categorical arrays are always protected. The default value is true when you specify 'Ordinal', true and false otherwise.

false	When you assign new values to B, the categories update automatically. Therefore, you can combine (nonordinal) categorical arrays that have different categories. The categories can update accordingly to include the categories from both arrays.
true	When you assign new values to B, the values must belong to one of the existing categories. Therefore, you can only combine arrays that have the same categories. To add new categories to B, you must use the function <code>addcats</code> .

Examples

Create Categorical Array from Strings

Convert a cell array of strings to a categorical array.

Create a cell array of strings.

```
A = {'r' 'b' 'g'; 'g' 'r' 'b'; 'b' 'r' 'g'}
```

A =

```
    'r'    'b'    'g'  
    'g'    'r'    'b'  
    'b'    'r'    'g'
```

A is a 3-by-3 cell array containing three unique values.

Convert the cell array of strings, A, to a categorical array, B.

```
B = categorical(A)
```

B =

```
    r    b    g  
    g    r    b  
    b    r    g
```

The contents of B match the contents of A.

Display the categories of B.

```
categories(B)
```

```
ans =
```

```
    'b'  
    'g'  
    'r'
```

The categories of B are the unique values from A in alphabetical order.

Create Categorical Array and Specify Possible Unique Values

Convert a cell array of strings, A, to a categorical array. Specify a list of categories that includes values that are not present in A.

Create a cell array of strings.

```
A = {'republican' 'democrat'; 'democrat' 'democrat'; 'democrat' 'republican'}
```

```
A =
```

```
    'republican'    'democrat'  
    'democrat'    'democrat'  
    'democrat'    'republican'
```

A is a 3-by-2 cell array containing two unique values.

Convert the cell array of strings, A, to a categorical array, B and include a category for independent.

```
valueset = {'democrat' 'republican' 'independent'}
```

```
B = categorical(A,valueset)
```

```
B =
```

```
    republican    democrat  
    democrat    democrat  
    democrat    republican
```

The contents of B match the contents of A.

Display the categories of B.

```
categories(B)

ans =

    'democrat'
    'republican'
    'independent'
```

The categories of B are in the same order as the values specified in `valueset`.

Create Categorical Array and Specify Category Names

Create a cell array of strings.

```
A = {'r' 'b' 'g'; 'g' 'r' 'b'; 'b' 'r' 'g'}
```

```
A =

    'r'    'b'    'g'
    'g'    'r'    'b'
    'b'    'r'    'g'
```

A is a 3-by-3 cell array containing three unique values.

Convert the cell array of strings, A, to a categorical array, B, and specify category names.

```
B = categorical(A,{'r' 'g' 'b'},{'red' 'green' 'blue'})
```

```
B =

    red    blue    green
    green  red    blue
```



```
         blue      red      green
```

B uses the specified category names for the contents from A.

Display the categories of B.

```
categories(B)
```

```
ans =
```

```
    'red'  
    'green'  
    'blue'
```

The categories of B are in the order they were specified.

Create Categorical Array from Integers

Create a 2-by-3 numeric array.

```
A = gallery('integerdata',3,[2,3],3)
```

```
A =
```

```
     2     1     2  
     1     1     3
```

A contains the values 1, 2, and 3.

Convert the numeric array, A, to a categorical array. Use the values 1, 2, and 3 to define the categories car, bus, and bike, respectively.

```
valueset = 1:3;  
catnames = {'car' 'bus' 'bike'};
```

```
B = categorical(A,valueset,catnames)
```

```
B =
```

```
     bus     car     bus
```

```
car    car    bike
```

`categorical` maps the numeric values in `valueset` to the category names in `catnames`.

The 2-by-3 categorical array, `B`, is not ordinal. Therefore, you can only compare the values in `B` for equality. To compare the values in `B` using relational operators, such as less than and greater than, you must include the `'Ordinal'`, true name-value pair argument.

Create Ordinal Categorical Array from Integers

Create a 5-by-2 numeric array.

```
A = gallery('integerdata',3,[5,2],1)
```

```
A =
```

```
3    2
3    3
3    2
2    1
3    2
```

`A` contains the values 1, 2, and 3.

Convert the numeric array, `A`, to an ordinal categorical array where 1, 2, and 3 represent child, adult, and senior respectively.

```
valueset = [1:3];
catnames = {'child' 'adult' 'senior'};
```

```
B = categorical(A,valueset,catnames,'Ordinal',true)
```

```
B =
```

```
senior    adult
senior    senior
senior    adult
```

```
      adult      child  
      senior     adult
```

Since B is ordinal, the categories of B have a mathematical ordering, `child < adult < senior`.

See Also

`categories`

Concepts

- “Advantages of Using Categorical Arrays”

categories

Purpose Categories of categorical array

Syntax `C = categories(A)`

Description `C = categories(A)` returns a cell array of strings containing the categories of the categorical array, A.

Input Arguments **A - Categorical array**
vector | matrix | multidimensional array

Categorical array, specified as a vector, matrix, or multidimensional array.

Examples **List Categories in Categorical Array**

Create a categorical array, A.

```
A = categorical({'plane' 'car' 'train' 'car' 'plane'})
```

```
A =
```

```
    plane    car    train    car    plane
```

A is a 1-by-5 categorical array.

Display the categories of A.

```
C = categories(A)
```

```
C =
```

```
    'car'  
    'plane'  
    'train'
```

Since you created A by specifying only an input array, the categories appear in alphabetical order.

List Categories in Ordinal Categorical Array

Create an ordinal categorical array.

```
A = categorical({'medium' 'large'; 'small' 'xlarge'; 'large' 'medium'},...
               {'small' 'medium' 'large' 'xlarge'},'Ordinal',true)
```

A =

```
      medium      large
      small      xlarge
      large      medium
```

A is a 3-by-2 ordinal categorical array.

Display the categories of A.

```
C = categories(A)
```

C =

```
'small'
'medium'
'large'
'xlarge'
```

The categories appear in the order in which you specified them. Since A is ordinal, the categories have the mathematical ordering `small < medium < large < xlarge`.

Tips

- C includes all categories in A, even if A does not contain any data from a category. To see the unique values in A, use `unique(A)`.
- The order of the categories listed in C is the same order used by functions, such as `summary` and `hist`. To change the order of the categories, use `reordercats`.

See Also

`categorical` | `unique` | `addcats` | `removecats` | `iscategory` | `mergecats` | `renamecats` | `reordercats` | `hist`

caxis

Purpose Color axis scaling

Syntax

```
caxis([cmin cmax])  
caxis auto  
caxis manual  
caxis(caxis)  
v = caxis  
caxis(axes_handle,...)
```

Description `caxis` controls the mapping of data values to the colormap. It affects any surfaces, patches, and images with indexed `CData` and `CDataMapping` set to `scaled`. It does not affect surfaces, patches, or images with `true color CData` or with `CDataMapping` set to `direct`.

`caxis([cmin cmax])` sets the color limits to specified minimum and maximum values. Data values less than `cmin` or greater than `cmax` map to `cmin` and `cmax`, respectively. Values between `cmin` and `cmax` linearly map to the current colormap.

`caxis auto` computes the color limits automatically using the minimum and maximum data values. This is the default behavior. Color values set to `Inf` map to the maximum color, and values set to `-Inf` map to the minimum color. Faces or edges with color values set to `NaN` are not drawn.

`caxis manual` and `caxis(caxis)` freeze the color axis scaling at the current limits. This enables subsequent plots to use the same limits when `hold` is on.

`v = caxis` returns a two-element row vector containing the `[cmin cmax]` currently in use.

`caxis(axes_handle,...)` uses the axes specified by `axes_handle` instead of the current axes.

`caxis` changes the `CLim` and `CLimMode` properties of axes graphics objects.

Tips

How Color Axis Scaling Works

Surface, patch, and image graphics objects having indexed CData and CDataMapping set to scaled map CData values to colors in the figure colormap each time they render. CData values equal to or less than cmin map to the first color value in the colormap, and CData values equal to or greater than cmax map to the last color value in the colormap. The following linear transformation is performed on the intermediate values (referred to as C below) to map them to an entry in the colormap (whose length is m, and whose row index is referred to as index below).

```
index = fix((C-cmin)/(cmax-cmin)*m)+1;
%Clamp values outside the range [1 m]
index(index<1) = 1;
index(index>m) = m;
```

Examples

Change Color Axis Scaling

Define X, Y, and Z as data for a sphere and view the data as a surface. Define the colors for the surface, C.

```
[X,Y,Z] = sphere;
C = Z;
surf(X,Y,Z,C)
```

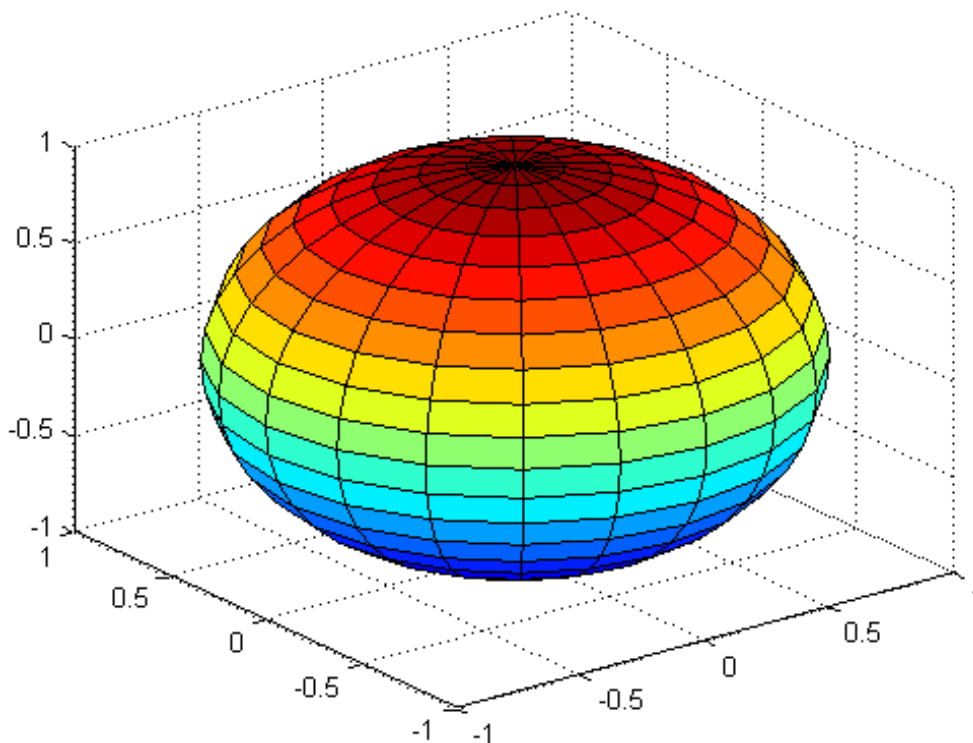

Values of C are in the range $[-1, 1]$. Values of C near -1 are assigned the lowest values in the colormap. Values of C near 1 are assigned the highest values in the colormap.

Map the top half of the surface to the highest value in the color table by setting the maximum color limit to 0 .

```
caxis([-1,0])
```

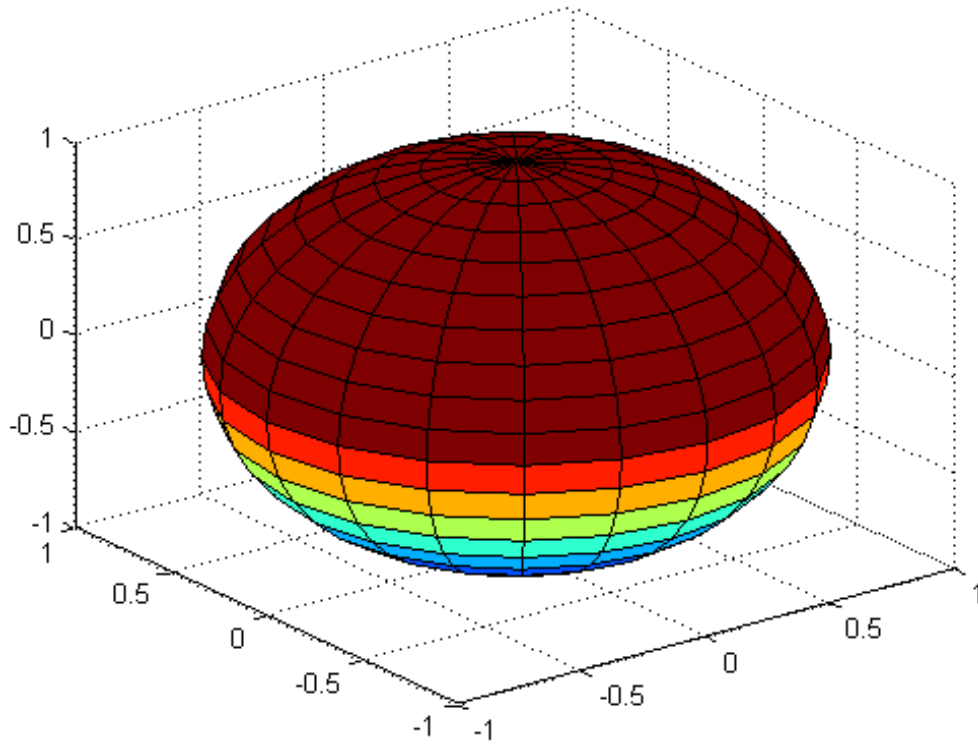
Reset the axis scaling back to its default range.

```
caxis auto
```

caxis

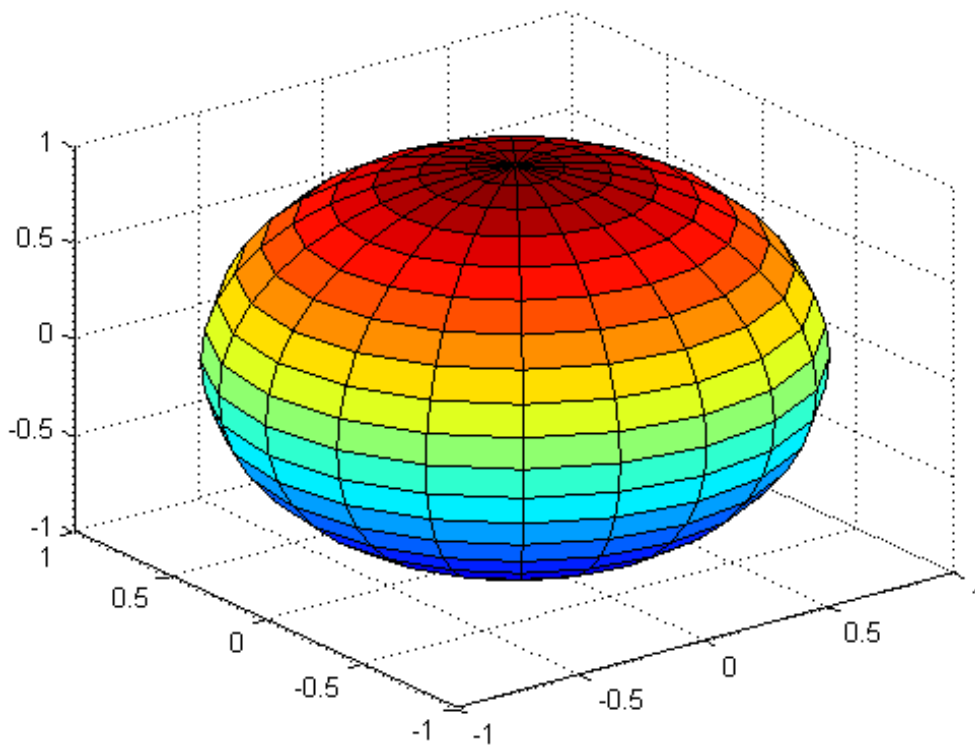

Return the values of the current color limits.

```
v = caxis
```

```
v =
```

```
    -1     1
```

Set Color Axis Scaling for Image Data

Load the cape file which contains the image data, X, and the colormap, map, for Cape Cod, Massachusetts.

```
load cape
```

Display the image with CDataMapping set to scaled, and use the map colormap.

```
figure  
image(X, 'CDataMapping', 'scaled')  
colormap(map)
```

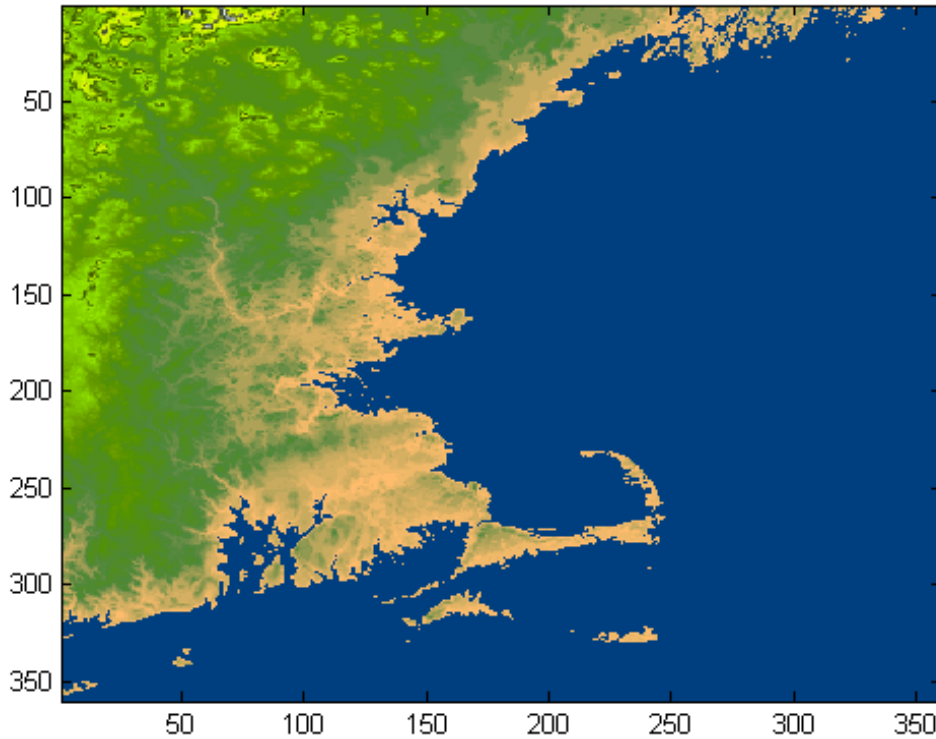

The color limits span the range of the image data, which is 1 to 192. The blue color of the ocean is the first color in the colormap and is mapped to the lowest data value, 1. You can effectively move sea level by changing the lower color limit value using `caxis`.

Display the image data using four different color limit values.

```
load cape
```

```
figure
```

```
colormap(map)

subplot(2,2,1)
image(X,'CDataMapping','scaled')
title('caxis = [1 192]')

subplot(2,2,2)
image(X,'CDataMapping','scaled')
caxis([4,192]) % change caxis
title('caxis = [4 192]')

subplot(2,2,3)
image(X,'CDataMapping','scaled')
caxis([7,192]) % change caxis
title('caxis = [7 192]')

subplot(2,2,4)
image(X,'CDataMapping','scaled')
caxis([10,192]) % change caxis
title('caxis = [10 192]')
```

caxis

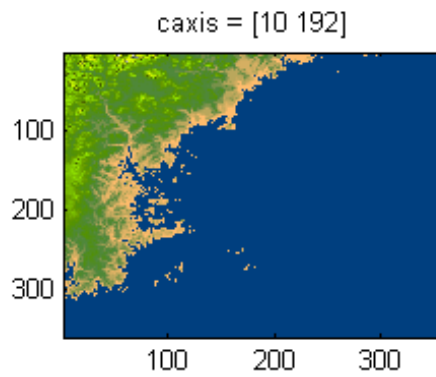
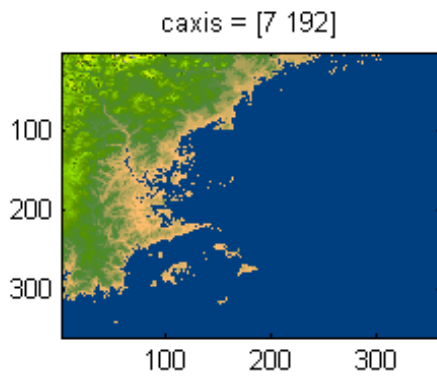
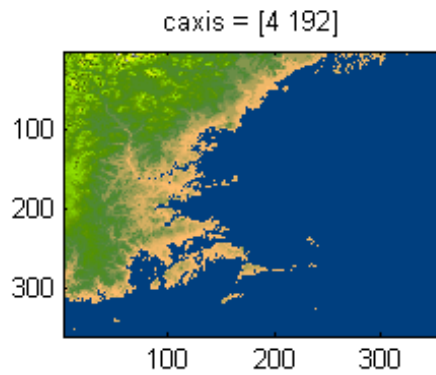
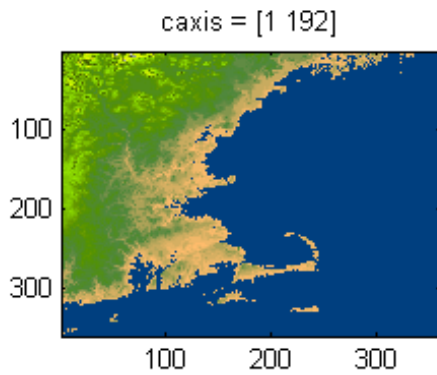

See Also

[axes](#) | [axis](#) | [colormap](#) | [get](#) | [mesh](#) | [pcolor](#) | [set](#) | [surf](#) | [CLim](#) | [Colormap](#) | [CLimMode](#)

How To

- “Axes Color Limits — the CLim Property”

Purpose	Change current folder
Syntax	<pre>cd(newFolder) oldFolder = cd(newFolder) cd</pre>
Description	<p><code>cd(newFolder)</code> changes the current folder to <code>newFolder</code>.</p> <p><code>oldFolder = cd(newFolder)</code> returns the existing current folder as a string to <code>oldFolder</code>, and then changes the current folder to <code>newFolder</code>.</p> <p><code>cd</code> displays the current folder.</p>
Tips	<ul style="list-style-type: none">• When using the command syntax (<code>cd newfolder</code>), if the <code>newFolder</code> string contains spaces, enclose the string in single quotation marks.• On UNIX platforms, use the <code>~</code> (tilde) character to represent the user home directory.• If you use <code>cd</code> within a local function, the folder change persists after program control returns from the function. That is, the scope of the folder change is global.
Input Arguments	<p>newFolder</p> <p>A string specifying the folder to which you want to change the current folder. Valid values can be any one of the following:</p> <ul style="list-style-type: none">• A full or relative path.• <code>../</code>, which indicates one level up from the current folder.• Multiple strings of <code>../</code>, which indicates multiple levels up from the current folder.• <code>./</code>, which indicates a path relative to the current folder, although without the <code>./</code>, <code>cd</code> assumes that the path is relative to the current folder.

Output Arguments

oldFolder

A string specifying the current folder that was in place when you issued the `cd` command.

Definitions

The current folder is a reference location that MATLAB uses to find files. This folder is sometimes referred to as the *current directory*, *current working folder*, or *present working directory*.

Examples

Use `cd` with the `matlabroot` function to change the current folder to the `examples` directory for the currently running version of MATLAB:

```
cd(fullfile(matlabroot, '/help/techdoc/matlab_env/examples'))
```

On a Microsoft Windows platform, specify the full path to change the current folder from any location to the `examples` directory for MATLAB Version 7.11 (R2010b), assuming that version is installed on your C: drive:

```
cd('C:/Program Files/MATLAB/R2010b/help/techdoc/matlab_env/examples')

% Change the current folder from
% C:/Program Files/MATLAB/R2010b/help/techdoc/matlab_env/examples to
% C:/Program Files/MATLAB/R2010b/help/techdoc:

cd ../../

% Use a relative path to change the current folder from
% C:/Program Files/MATLAB/R2010b/help/techdoc back to
% C:/Program Files/MATLAB/R2010b/help/techdoc/matlab_env/examples:

cd matlab_env/examples

% Change the current folder from its current location to a new
% location, but save its previous location. Later, change the
% current folder to the previous location.
```

```
% This returns
% C:/Program Files/MATLAB/R2010b/help/techdoc/matlab_env/examples
% to oldFolder, and then changes the current folder to
% C:/Program Files:

oldFolder = cd('C:/Program Files')

% Display current folder:

pwd

% Change the current folder to the previous location:
cd(oldFolder)

pwd
```

On a UNIX platform, change the current folder to the examples directory for the currently running version of MATLAB, assuming it is installed in your home location:

```
cd('~ /help/techdoc/matlab_env/examples')
```

See Also

```
dir | fileparts | path | pwd | what
```

How To

- “Specify File Names”
- “Files and Folders that MATLAB Accesses”

DelaunayTri.convexHull

Purpose (Will be removed) Convex hull

Note `convexHull(DelaunayTri)` will be removed in a future release. Use `convexHull(delaunayTriangulation)` instead.

`DelaunayTri` will be removed in a future release. Use `delaunayTriangulation` instead.

Syntax
`K = convexHull(DT)`
`[K AV] = convexHull(DT)`

Description `K = convexHull(DT)` returns the indices into the array of points `DT.X` that correspond to the vertices of the convex hull.
`[K AV] = convexHull(DT)` returns the convex hull and the area or volume bounded by the convex hull.

Input Arguments

DT	Delaunay triangulation.
----	-------------------------

Output Arguments

K	If the points lie in 2-D space, K is a column vector of length <code>numf</code> . Otherwise K is a matrix of size <code>numf-by-ndim</code> , <code>numf</code> being the number of facets in the convex hull, and <code>ndim</code> the dimension of the space where the points reside.
AV	The area or volume of the convex hull.

Definitions The convex hull of a set of points `X` is the smallest convex region containing all of the points of `X`.

Examples

Example 1

Compute the convex hull of a set of random points located within a unit square in 2-D space.

```
x = rand(10,1)
y = rand(10,1)
dt = DelaunayTri(x,y)
k = convexHull(dt)
plot(dt.X(:,1),dt.X(:,2), '.','markersize',10); hold on;
plot(dt.X(k,1),dt.X(k,2), 'r'); hold off;
```

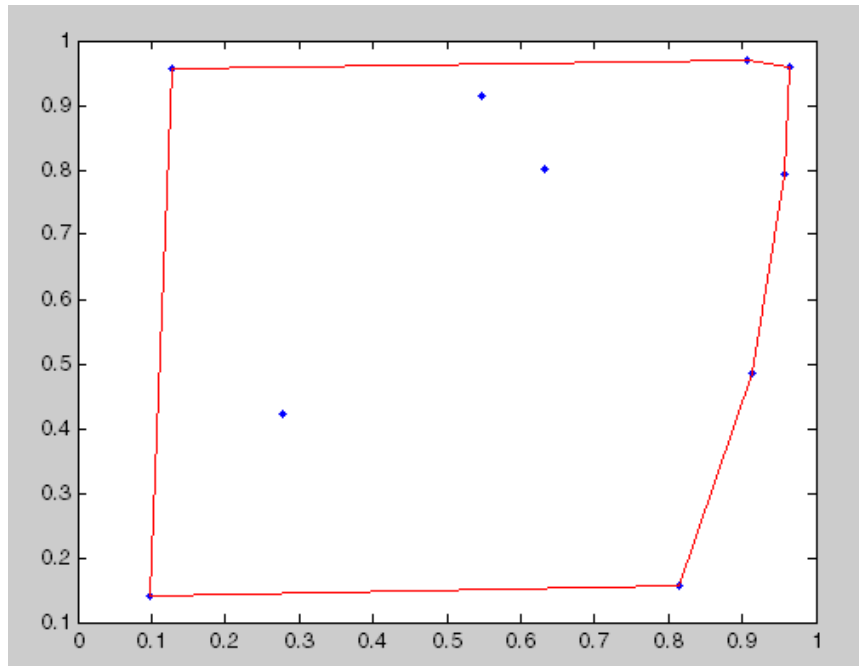

Example 2

Compute the convex hull of a set of random points located within a unit cube in 3-D space, and the volume bounded by the convex hull.

DelaunayTri.convexHull

```
X = rand(25,3)
dt = DelaunayTri(X)
[ch v] = convexHull(dt)
trisurf(ch, dt.X(:,1),dt.X(:,2),dt.X(:,3), 'FaceColor', 'cyan')
```

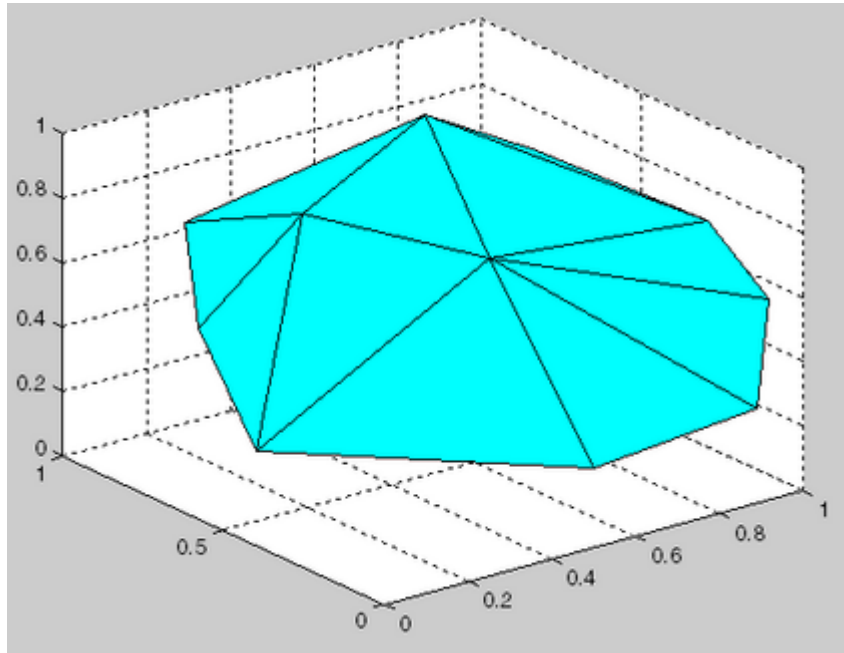

See Also

[voronoiDiagram](#) | [delaunayTriangulation](#) | [triangulation](#) | [convhull](#) | [convhulln](#)

Purpose	Change or view current folder on FTP server
Syntax	<code>cd(ftpobj, folder)</code> <code>cd(ftpobj)</code>
Description	<code>cd(ftpobj, folder)</code> changes the current folder on the FTP server. <code>cd(ftpobj)</code> displays the current folder on the server.
Input Arguments	ftpobj FTP object created by <code>ftp</code> . folder String enclosed in single quotation marks that specifies the target folder. To specify the folder above the current one, use <code>'..'</code> .
Examples	Connect to the MathWorks FTP server, change to the pub folder, and view its contents: <pre>mw=ftp('ftp.mathworks.com'); cd(mw, 'pub'); dir(mw)</pre>
See Also	<code>dir</code> <code>ftp</code>

cdf2rdf

Purpose Convert complex diagonal form to real block diagonal form

Syntax $[V,D] = \text{cdf2rdf}(V,D)$
 $[V,D] = \text{cdf2rdf}(V,D)$

Description If the eigensystem $[V,D] = \text{eig}(X)$ has complex eigenvalues appearing in complex-conjugate pairs, `cdf2rdf` transforms the system so D is in real diagonal form, with 2-by-2 real blocks along the diagonal replacing the complex pairs originally there. The eigenvectors are transformed so that

$$X = V*D/V$$

continues to hold. The individual columns of V are no longer eigenvectors, but each pair of vectors associated with a 2-by-2 block in D spans the corresponding invariant vectors.

Examples The matrix

$$X = \begin{bmatrix} 1 & 2 & 3 \\ 0 & 4 & 5 \\ 0 & -5 & 4 \end{bmatrix}$$

has a pair of complex eigenvalues.

$$[V,D] = \text{eig}(X)$$

$$V = \begin{bmatrix} 1.0000 & -0.0191 - 0.4002i & -0.0191 + 0.4002i \\ 0 & 0 - 0.6479i & 0 + 0.6479i \\ 0 & 0.6479 & 0.6479 \end{bmatrix}$$

$$D = \begin{bmatrix} 1.0000 & & \\ & 0 & \\ & & 0 \end{bmatrix}$$

$$\begin{array}{ccc} 0 & 4.0000 + 5.0000i & 0 \\ 0 & 0 & 4.0000 - 5.0000i \end{array}$$

Converting this to real block diagonal form produces

$$[V,D] = \text{cdf2rdf}(V,D)$$

V =

$$\begin{array}{ccc} 1.0000 & -0.0191 & -0.4002 \\ 0 & 0 & -0.6479 \\ 0 & 0.6479 & 0 \end{array}$$

D =

$$\begin{array}{ccc} 1.0000 & 0 & 0 \\ 0 & 4.0000 & 5.0000 \\ 0 & -5.0000 & 4.0000 \end{array}$$

Algorithms

The real diagonal form for the eigenvalues is obtained from the complex form using a specially constructed similarity transformation.

See Also

eig | rsf2csf

cdfepoch

Purpose Convert MATLAB formatted dates to CDF formatted dates

Syntax `E = cdfepoch(date)`

Description `E = cdfepoch(date)` converts the date, specified by `date`, into a `cdfepoch` object. `date` must be a valid date string, returned by `datestr`, or a serial date number, returned by `datenum`. `date` can also be a `cdfepoch` object.

When writing data to a CDF file using `cdfwrite`, use `cdfepoch` to convert MATLAB formatted dates to CDF formatted dates. The MATLAB `cdfepoch` object simulates the `CDFEPOCH` data type in CDF files.

To convert a `cdfepoch` object into a MATLAB serial date number, use the `todatenum` function.

Definitions The MATLAB serial date number calculates dates differently than CDF epochs.

A MATLAB serial date number represents the whole and fractional number of days from 1-Jan-0000 to a specific date. The year 0000 is merely a reference point and is not intended to be interpreted as a real year in time.

A CDF epoch is the number of milliseconds since 1-Jan-0000.

Examples Convert the current time in serial date number format into a CDF epoch object.

```
% NOW function returns current time as serial date number
dateobj = cdfepoch(now)
```

```
dateobj =
```

```
    cdfepoch object:
    11-Mar-2009 15:09:25
```

Convert the current time in date string format into a CDF epoch object.

```
% DATESTR function returns date as string
dateobj2 = cdfepoch(datestr(now))
```

```
dateobj2 =
```

```
    cdfepoch object:
    11-Mar-2009 15:09:25
```

Convert the CDF epoch object into a serial date number.

```
dateobj = cdfepoch(now);
mydatenum = todatenum(dateobj)
```

```
mydatenum =
```

```
    7.3384e+005
```

See Also

[datenum](#) | [datestr](#) | [todatenum](#) | [cdfinfo](#) | [cdfread](#)

cdfinfo

Purpose Information about Common Data Format (CDF) file

Syntax `info = cdfinfo(filename)`

Description `info = cdfinfo(filename)` returns information about the Common Data Format (CDF) file specified in the string `filename`.

Note Because `cdfinfo` creates temporary files, the current working directory must be writeable.

The following table lists the fields returned in the structure, `info`. The table lists the fields in the order that they appear in the structure.

Field	Description
Filename	Text string specifying the name of the file
FileModDate	Text string indicating the date the file was last modified
FileSize	Double scalar specifying the size of the file, in bytes
Format	Text string specifying the file format
FormatVersion	Text string specifying the version of the CDF library used to create the file
FileSettings	Structure array containing library settings used to create the file
Subfiles	Filenames containing the CDF file's data, if it is a multi-file format CDF

Field	Description	
Variables	N-by-6 cell array, where N is the number of variables, containing information about the variables in the file. The columns present the following information:	
	Column 1	Text string specifying name of variable
	Column 2	Double array specifying the dimensions of the variable, as returned by the <code>size</code> function
	Column 3	Double scalar specifying the number of records assigned for the variable
	Column 4	Text string specifying the data type of the variable, as stored in the CDF file
	Column 5	Text string specifying the record and dimension variance settings for the variable. The single T or F to the left of the slash designates whether values vary by record. The zero or more T or F letters to the right of the slash designate whether values vary at each dimension. Here are some examples. T/ (scalar variable) F/T (one-dimensional variable) T/TFF (three-dimensional variable)

Field	Description
GlobalAttributes	Structure array that contains one field for each global attribute. The name of each field corresponds to the name of an attribute. The data in each field, contained in a cell array, represents the entry values for that attribute.
VariableAttributes	Structure array that contains one field for each variable attribute. The name of each field corresponds to the name of an attribute. The data in each field is contained in a n -by-2 cell array, where n is the number of variables. The first column of this cell array contains the variable names associated with the entries. The second column contains the entry values.

Note Attribute names returned by `cdfinfo` might not match the names of the attributes in the CDF file exactly. Attribute names can contain characters that are illegal in MATLAB field names. `cdfinfo` removes illegal characters that appear at the beginning of attributes and replaces other illegal characters with underscores ('_'). When `cdfinfo` modifies an attribute name, it appends the attribute's internal number to the end of the field name. For example, the attribute name `Variable%Attribute` becomes `Variable_Attribute_013`.

Note To improve performance, turn off the file validation which the CDF library does by default when opening files. For more information, see `cdflib.setValidate`.

Examples

Get Information About CDF File

Get information about the sample file, `example.cdf`.

```

info = cdfinfo('example.cdf')

info =

    Filename: 'example.cdf'
    FileModDate: '13-May-2010 13:38:20'
    FileSize: 1310
    Format: 'CDF'
    FormatVersion: '2.7.0'
    FileSettings: [1x1 struct]
    Subfiles: {}
    Variables: {6x6 cell}
    GlobalAttributes: [1x1 struct]
    VariableAttributes: [1x1 struct]

```

View information about the variables in the file.

```
info.Variables
```

```
ans =
```

```
Columns 1 through 5
```

'Time'	[1x2 double]	[24]	'epoch'	'T/'
'Longitude'	[1x2 double]	[1]	'int8'	'F/FT'
'Latitude'	[1x2 double]	[1]	'int8'	'F/TF'
'Data'	[1x3 double]	[1]	'double'	'T/TTT'
'multidimensional'	[1x4 double]	[1]	'uint8'	'T/TTTT'
'Temperature'	[1x2 double]	[10]	'int16'	'T/TT'

```
Column 6
```

```
'Full'
'Full'
```

cdfinfo

```
'Full'  
'Full'  
'Full'  
'Full'
```

See Also

[cdflib.setValidate](#) | [cdfread](#)

Purpose

Summary of Common Data Format (CDF) capabilities

Description

The MATLAB product provides both high-level and low-level access to Common Data Format (CDF) files. The high-level access functions make it easy to read data from a CDF file or write data from the workspace to a CDF file. The low-level interface provides you with more control over the import and export operations.

Note For information about MATLAB support for the Network Common Data Form (netCDF), which is a completely separate, incompatible format, see `netcdf`.

High-Level Functions

MATLAB includes functions that provide high-level access to CDF files:

- `cdfinfo`
- `cdfread`

In addition, MATLAB provides functions that convert time data to and from the CDF epoch data type: `cdfepoch` and `todatenum`.

Low-Level Functions

MATLAB provides direct access to dozens of functions in the CDF library. Using these functions, you can read and write data, create variables, attributes, and entries, and take advantage of other features of the CDF library. To use these functions, you must be familiar with the CDF C interface. Documentation about CDF, version 3.3.0, is available at the [CDF Web site](#).

The MATLAB functions correspond to functions in the CDF library new Standard Interface. In most cases, the syntax of a MATLAB function is similar to the syntax of the corresponding CDF library function. To use these functions, you must prefix the function name with the package name, `cdflib`. For example, to use the CDF library function to open an existing CDF file, you would use this syntax:

```
cdfid = cdflib.open('example.cdf');
```

The following tables list all of the functions in the MATLAB CDF library package, grouped by category.

Library Information

<code>cdflib</code>	Summary of Common Data Format (CDF) capabilities
<code>cdflib.getConstantNames</code>	Names of Common Data Format (CDF) library constants
<code>cdflib.getConstantValue</code>	Numeric value corresponding to Common Data Format (CDF) library constant
<code>cdflib.getFileBackward</code>	Return current backward compatibility mode setting
<code>cdflib.getLibraryCopyright</code>	Copyright notice of Common Data Format (CDF) library
<code>cdflib.getLibraryVersion</code>	Library version and release information
<code>cdflib.getValidate</code>	Library validation mode
<code>cdflib.setFileBackward</code>	Set backward compatibility mode
<code>cdflib.setValidate</code>	Specify library validation mode

File Operations

<code>cdflib.close</code>	Close Common Data Format (CDF) file
<code>cdflib.create</code>	Create Common Data Format (CDF) file
<code>cdflib.delete</code>	Delete existing Common Data Format (CDF) file
<code>cdflib.getCacheSize</code>	Number of cache buffers used
<code>cdflib.getChecksum</code>	Checksum mode

<code>cdflib.getCompression</code>	Compression settings
<code>cdflib.getCompressionCacheSize</code>	Number of compression cache buffers
<code>cdflib.getCopyright</code>	Copyright notice in Common Data Format (CDF) file
<code>cdflib.getFormat</code>	Format of Common Data Format (CDF) file
<code>cdflib.getMajority</code>	Majority of variables
<code>cdflib.getName</code>	Name of Common Data Format (CDF) file
<code>cdflib.getReadOnlyMode</code>	Read-only mode
<code>cdflib.getStageCacheSize</code>	Number of cache buffers for staging
<code>cdflib.getVersion</code>	Common Data Format (CDF) library version and release information
<code>cdflib.inquire</code>	Basic characteristics of Common Data Format (CDF) file
<code>cdflib.open</code>	Open existing Common Data Format (CDF) file
<code>cdflib.setCacheSize</code>	Specify number of dotCDF cache buffers
<code>cdflib.setChecksum</code>	Specify checksum mode
<code>cdflib.setCompression</code>	Specify compression settings
<code>cdflib.setCompressionCacheSize</code>	Specify number of compression cache buffers
<code>cdflib.setFormat</code>	Specify format of Common Data Format (CDF) file
<code>cdflib.setMajority</code>	Specify majority of variables

<code>cdflib.setReadOnlyMode</code>	Specify read-only mode
<code>cdflib.setStageCacheSize</code>	Specify number of staging cache buffers for Common Data Format (CDF) file

Variables

<code>cdflib.closeVar</code>	Close specified variable from multifile format Common Data Format (CDF) file
<code>cdflib.createVar</code>	Create new variable
<code>cdflib.deleteVar</code>	Delete variable
<code>cdflib.deleteVarRecords</code>	Delete range of records from variable
<code>cdflib.getVarAllocRecords</code>	Number of records allocated for variable
<code>cdflib.getVarBlockingFactor</code>	Blocking factor for variable
<code>cdflib.getVarCacheSize</code>	Number of multifile cache buffers
<code>cdflib.getVarCompression</code>	Information about compression used by variable
<code>cdflib.getVarData</code>	Single value from record in variable
<code>cdflib.getVarMaxAllocRecNum</code>	Maximum allocated record number for variable
<code>cdflib.getVarMaxWrittenRecNum</code>	Maximum written record number for variable
<code>cdflib.getVarName</code>	Variable name, given variable number
<code>cdflib.getVarNum</code>	Variable number, given variable name

<code>cdflib.getVarNumRecsWritten</code>	Number of records written to variable
<code>cdflib.getVarPadValue</code>	Pad value for variable
<code>cdflib.getVarRecordData</code>	Entire record for variable
<code>cdflib.getVarReservePercent</code>	Compression reserve percentage for variable
<code>cdflib.getVarsMaxWrittenRecNum</code>	Maximum written record number for CDF file
<code>cdflib.getVarSparseRecords</code>	Information about how variable handles sparse records
<code>cdflib.hyperGetVarData</code>	Read hyperslab of data from variable
<code>cdflib.hyperPutVarData</code>	Write hyperslab of data to variable
<code>cdflib.inquireVar</code>	Information about variable
<code>cdflib.putVarData</code>	Write single value to variable
<code>cdflib.putVarRecordData</code>	Write entire record to variable
<code>cdflib.renameVar</code>	Rename existing variable
<code>cdflib.setVarAllocBlockRecords</code>	Specify range of records to be allocated for variable
<code>cdflib.setVarBlockingFactor</code>	Specify blocking factor for variable
<code>cdflib.setVarCacheSize</code>	Specify number of multi-file cache buffers for variable
<code>cdflib.setVarCompression</code>	Specify compression settings used with variable
<code>cdflib.setVarInitialRecs</code>	Specify initial number of records written to variable

<code>cdflib.setVarPadValue</code>	Specify pad value used with variable
<code>cdflib.SetVarReservePercent</code>	Specify reserve percentage for variable
<code>cdflib.setVarsCacheSize</code>	Specify number of cache buffers used for all variables
<code>cdflib.setVarSparseRecords</code>	Specify how variable handles sparse records

Attributes

<code>cdflib.createAttr</code>	Create attribute
<code>cdflib.deleteAttr</code>	Delete attribute
<code>cdflib.deleteAttrEntry</code>	Delete attribute entry
<code>cdflib.deleteAttrgEntry</code>	Delete entry in global attribute
<code>cdflib.getAttrEntry</code>	Value of entry in attribute with variable scope
<code>cdflib.getAttrgEntry</code>	Value of entry in global attribute
<code>cdflib.getAttrMaxEntry</code>	Number of last entry for variable attribute
<code>cdflib.getAttrMaxgEntry</code>	Number of last entry for global attribute
<code>cdflib.getAttrName</code>	Name of attribute, given attribute number
<code>cdflib.getAttrNum</code>	Attribute number, given attribute name
<code>cdflib.getAttrScope</code>	Scope of attribute
<code>cdflib.getNumAttrEntries</code>	Number of entries for attribute with variable scope
<code>cdflib.getNumAttrgEntries</code>	Number of entries for attribute with global scope

<code>cdflib.getNumAttributes</code>	Number of attributes with variable scope
<code>cdflib.getNumgAttributes</code>	Number of attributes with global scope
<code>cdflib.inquireAttr</code>	Information about attribute
<code>cdflib.inquireAttrEntry</code>	Information about entry in attribute with variable scope
<code>cdflib.inquireAttrgEntry</code>	Information about entry in attribute with global scope
<code>cdflib.putAttrEntry</code>	Write value to entry in attribute with variable scope
<code>cdflib.putAttrgEntry</code>	Write value to entry in attribute with global scope
<code>cdflib.renameAttr</code>	Rename existing attribute

Utility Functions

<code>cdflib.computeEpoch</code>	Convert time value to CDF_EPOCH value
<code>cdflib.computeEpoch16</code>	Convert time value to CDF_EPOCH16 value
<code>cdflib.epoch16Breakdown</code>	Convert CDF_EPOCH16 value to time value
<code>cdflib.epochBreakdown</code>	Convert CDF_EPOCH value into time value

See Also

`cdfread` | `cdfinfo`

Tutorials

- “Importing CDF Files”
- “Exporting to CDF Files”

cdflib.close

Purpose	Close Common Data Format (CDF) file
Syntax	<code>cdflib.close(cdfId)</code>
Description	<p><code>cdflib.close(cdfId)</code> closes the specified CDF file. <code>cdfId</code> identifies the CDF file.</p> <p>You must close a CDF to guarantee that all modifications you made since opening the CDF are actually written to the file.</p>
Examples	<p>Open the example CDF file and then close it.</p> <pre>cdfid = cdflib.open('example.cdf'); cdflib.close(cdfid)</pre>
References	<p>This function corresponds to the CDF library C API routine <code>CDFcloseCDF</code>.</p> <p>To use this function, you must be familiar with the CDF C interface. Read the CDF documentation at the CDF Web site.</p> <p>For copyright information, see the <code>cdfcopyright.txt</code> file.</p>
See Also	<code>cdflib.open</code> <code>cdflib.create</code>
Tutorials	<ul style="list-style-type: none">• “Importing CDF Files”• “Exporting to CDF Files”

Purpose	Close specified variable from multifile format Common Data Format (CDF) file
Syntax	<code>cdflib.closeVar(cdfId,varNum)</code>
Description	<p><code>cdflib.closeVar(cdfId,varNum)</code> closes a variable in a multifile format CDF.</p> <p><code>cdfId</code> identifies the CDF file and <code>varNum</code> is a numeric value that specifies the variable. Variable identifiers (variable numbers) are zero-based.</p> <p>For multifile CDFs, you must close all open variable files to guarantee that all modifications you have made are actually written to the CDF file(s). You do not need to call this function for variables in a single-file format CDF.</p>
Examples	<p>Create a multifile CDF, create a variable, and then close the variable. To run this example, you must be in a writable folder.</p> <pre>cdfid = cdflib.create('your_multifile.cdf'); % Make it a multifile format CDF cdflib.setFormat(cdfid,'MULTI_FILE') % Create a variable in the CDF. varNum = cdflib.createVar(cdfid,'Time','cdf_int1',1,[],true,[]); % Close the variable. cdflib.closeVar(cdfid, varnum) % Clean up cdflib.delete(cdfid) clear cdfid</pre>
References	This function corresponds to the CDF library C API routine <code>CDFclosezVar</code> .

cdflib.closeVar

To use this function, you must be familiar with the CDF C interface. Read the CDF documentation at the [CDF Web site](#).

For copyright information, see the `cdfcopyright.txt` file.

See Also

`cdflib.getVarNum` | `cdflib.setFormat` | `cdflib.getFormat`

Tutorials

- “Importing CDF Files”
- “Exporting to CDF Files”

Purpose Convert time value to CDF_EPOCH value

Syntax `epoch = cdflib.computeEpoch(timeval)`

Description `epoch = cdflib.computeEpoch(timeval)` converts the time value specified by `timeval` into a CDF_EPOCH value.

Input Arguments **timeval**

7-by-1 time vector. The following table describes the time components.

Component	Description
year	AD e.g. 1994
month	1 12
day	1 31
hour	0 23
minute	0 59
second	0 59
millisecond	0 999

Output Arguments **epoch**

MATLAB double representing a CDF_EPOCH time value.

Examples Convert a time value into a CDF_EPOCH value.

```
timeval = [1999 12 31 23 59 59 0];  
epoch = cdflib.computeEpoch(timeval);
```

References This function corresponds to the CDF library C API routine `computeEPOCH`.

To use this function, you must be familiar with the CDF C interface. Read the CDF documentation at the [CDF Web site](#).

cdflib.computeEpoch

For copyright information, see the `cdfcopyright.txt` file.

See Also

`cdflib.computeEpoch16` | `cdflib.epochBreakdown` |
`cdflib.epoch16Breakdown`

Tutorials

- “Importing CDF Files”
- “Exporting to CDF Files”

Purpose Convert time value to CDF_EPOCH16 value

Syntax `epoch16 = cdflib.computeEpoch16(timeval)`

Description `epoch16 = cdflib.computeEpoch16(timeval)` converts the time value specified by `timeval` into a CDF_EPOCH16 value.

Input Arguments **timeval**

10-by-1 time vector. The following table describes the time components. To specify multiple time values, use additional columns.

Component	Description
year	AD e.g. 1994
month	1 12
day	1 31
hour	0 23
minute	0 59
second	0 59
millisecond	0 999
microsecond	0 999
nanosecond	0 999
picosecond	0 999

Output Arguments **epoch16**

CDF Epoch16 time value. If the input argument `timeval` has `m`-by-10 elements, the return value `epoch16` will have size 2-by-`m`

Examples Convert the time value into an CDF_EPOCH16 value:

```
timeval = [1999; 12; 31; 23; 59; 59; 50; 100; 500; 999];
```

cdflib.computeEpoch16

```
epoch16 = cdflib.computeEpoch16(timeval);
```

References

This function corresponds to the CDF library C API routine `computeEPOCH16`.

To use this function, you must be familiar with the CDF C interface. Read the CDF documentation at the [CDF Web site](#).

For copyright information, see the `cdfcopyright.txt` file.

See Also

`cdflib.computeEpoch` | `cdflib.epochBreakdown` | `cdflib.epoch16Breakdown`

Tutorials

- “Importing CDF Files”
- “Exporting to CDF Files”

Purpose	Create Common Data Format (CDF) file
Syntax	<code>cdfId = cdflib.create(filename)</code>
Description	<code>cdfId = cdflib.create(filename)</code> creates a new CDF file with the name specified by the text string <i>filename</i> . Returns the CDF file identifier <code>cdfId</code> .
Examples	<p>Create a CDF file. To run this example, you must have write permission in your current directory.</p> <pre>cdfId = cdflib.create('myfile.cdf'); % Clean up cdflib.delete(cdfId); clear cdfId</pre>
References	<p>This function corresponds to the CDF library C API routine <code>CDFcreateCDF</code>.</p> <p>To use this function, you must be familiar with the CDF C interface. Read the CDF documentation at the CDF Web site.</p> <p>For copyright information, see the <code>cdfcopyright.txt</code> file.</p>
See Also	<code>cdflib.open</code> <code>cdflib.close</code>
Tutorials	<ul style="list-style-type: none">• “Importing CDF Files”• “Exporting to CDF Files”

cdflib.createAttr

Purpose Create attribute

Syntax `attrnum = cdflib.createAttr(cdfId,attrName,scope)`

Description `attrnum = cdflib.createAttr(cdfId,attrName,scope)` creates an attribute in a CDF file with the specified scope.

Input Arguments

`cdfId`

Identifier of a CDF file, returned by a call to `cdflib.create` or `cdflib.open`.

`attrName`

Text string that specifies the name you want to assign to the attribute.

`scope`

One of the following text strings, or its numeric equivalent, that specifies the scope of the attribute.

Text String	Description
'global_scope'	Attribute applies to the CDF as a whole.
'variable_scope'	Attribute applies only to the variable

To get the numeric equivalent of these text string constants, use the `cdflib.getConstantValue` function.

Output Arguments

`attrNum`

Numeric value identifying the attribute. Attribute numbers are zero-based.

Examples

Create a CDF, and then create an attribute in the CDF. To run this example, you must be in a writable folder.

```
cdfid = cdflib.create('your_file.cdf');

% Create attribute
attrNum = cdflib.createAttr(cdfid, 'Purpose', 'global_scope');

% Clean up
cdflib.delete(cdfid);

clear cdfid
```

References

This function corresponds to the CDF library C API routine `CDFcreateAttr`.

To use this function, you must be familiar with the CDF C interface. Read the CDF documentation at the [CDF Web site](#).

For copyright information, see the `cdfcopyright.txt` file.

See Also

`cdflib.getAttrNum` | `cdflib.deleteAttr` |
`cdflib.getConstantValue` | `cdflib.getConstantNames`

Tutorials

- “Importing CDF Files”
- “Exporting to CDF Files”

cdflib.createVar

Purpose Create new variable

Syntax `varnum = cdflib.createVar(cdfId, varname, datatype, numElements, dims, recVariance, dimVariance)`

Description `varnum = cdflib.createVar(cdfId, varname, datatype, numElements, dims, recVariance, dimVariance)` creates a new variable in the Common Data Format (CDF) file with the specified characteristics.

Input Arguments

`cdfId`

Identifier of a CDF file, returned by a call to `cdflib.create` or `cdflib.open`.

`varname`

Text string that specifies the name you want to assign to the variable.

`datatype`

Data type of the variable. One of the following text strings, or its numeric equivalent, that specifies a valid CDF data type.

CDF Data Type	Description
CDF_BYTE	1-byte, signed integer
CDF_CHAR	1 byte, signed character data type that maps to the MATLAB char class
CDF_INT1	1-byte, signed integer
CDF_UCHAR	1 byte, unsigned character data type that maps to the MATLAB uint8 class
CDF_UINT1	1-byte, unsigned integer
CDF_INT2	2-byte, signed integer

CDF Data Type	Description
CDF_UINT2	2-byte, unsigned integer
CDF_INT4	4-byte, signed integer
CDF_UINT4	4-byte, unsigned integer
CDF_FLOAT	4-byte, floating point
CDF_REAL4	4-byte, floating point
CDF_REAL8	8-byte, floating point.
CDF_DOUBLE	8-byte, floating point
CDF_EPOCH	8-byte, floating point
CDF_EPOCH16	two 8-byte, floating point

numElements

Number of elements per datum. Value should be 1 for all data types, except CDF_CHAR and CDF_UCHAR.

dims

A vector of the dimensions extents; empty if there are no dimension extents.

recVariance

Specifies record variance: true or false.

dimVariance

A vector of logicals; empty if there are no dimensions.

Output Arguments**varNum**

The numeric identifier for the variable. Variable numbers are zero-based.

Examples

Create a CDF file and then create a variable named 'Time' in the CDF. The variable has no dimensions and varies across records. To run this example, you must be in a writable folder.

```
cdfid = cdflib.create('your_file.cdf');

% Initially the file contains no variables.
info = cdflib.inquire(cdfid)

info =

    encoding: 'IBMPC_ENCODING'
    majority: 'ROW_MAJOR'
    maxRec: -1
    numVars: 0
    numvAttrs: 0
    numgAttrs: 0

% Create a variable in the file.
varNum = cdflib.createVar(cdfid,'Time','cdf_int1',1,[],true,[]);

% Retrieve info about the file again to verify variable was created.
% Note value of numVars field is now 1.
info = cdflib.inquire(cdfid)

info =

    encoding: 'IBMPC_ENCODING'
    majority: 'ROW_MAJOR'
    maxRec: -1
    numVars: 1
    numvAttrs: 0
    numgAttrs: 0

% Clean up
cdflib.delete(cdfid);
```

```
clear cdfid
```

References

This function corresponds to the CDF library C API routine `CDFcreatezVar`.

To use this function, you must be familiar with the CDF C interface. Read the CDF documentation at the [CDF Web site](#).

For copyright information, see the `cdfcopyright.txt` file.

See Also

`cdflib.deleteVar` | `cdflib.closeVar`

Tutorials

- “Importing CDF Files”
- “Exporting to CDF Files”

cdflib.delete

Purpose Delete existing Common Data Format (CDF) file

Syntax `cdflib.delete(cdfId)`

Description `cdflib.delete(cdfId)` deletes the existing CDF file specified by the identifier `cdfId`. If the CDF file is a multi-file format CDF, the `cdflib.delete` function also deletes the variable files (having file extensions of `.z0`, `.z1`, etc.).

Examples Create a CDF file, and then delete it. To run this example, you must be in a writable folder.

```
cdfId = cdflib.create('mytempfile.cdf');
```

```
% Verify that the file was created.  
ls *.cdf
```

```
mytempfile.cdf
```

```
% Delete the file.  
cdflib.delete(cdfId)
```

```
% Verify that the file no longer exists.  
ls *.cdf
```

References This function corresponds to the CDF library C API routine `CDFdeleteCDF`.

To use this function, you must be familiar with the CDF C interface. Read the CDF documentation at the [CDF Web site](#).

For copyright information, see the `cdfcopyright.txt` file.

See Also `cdflib.create` | `cdflib.setFormat`

Tutorials

- “Importing CDF Files”
- “Exporting to CDF Files”

Purpose Delete attribute

Syntax `cdflib.deleteAttr(cdfId,attrNum)`

Description `cdflib.deleteAttr(cdfId,attrNum)` deletes the specified attribute from the CDF file.

`cdfId` identifies the Common Data Format (CDF) file.`attrNum` is a numeric identifier that specifies the attribute. Attribute numbers are zero-based.

Examples Create a CDF file, and then create an attribute in the file. Then delete the attribute. To run this example, you must be in a writable folder.

```
cdfid = cdflib.create('your_file.cdf');

% Create attribute.
attrNum = cdflib.createAttr(cdfId, 'Purpose', 'global_scope');

% Prove it exists.
anum = cdflib.getAttrNum(cdfid, 'Purpose')

anum =

    0

% Delete the attribute.
cdflib.deleteAttr(cdfid,attrNum);

% Clean up
cdflib.delete(cdfid);

clear cdfid
```

References This function corresponds to the CDF library C API routine `CDFdeleteAttr`.

cdflib.deleteAttr

To use this function, you must be familiar with the CDF C interface. Read the CDF documentation at the [CDF Web site](#).

For copyright information, see the `cdfcopyright.txt` file.

See Also

`cdflib.createAttr` | `cdflib.getAttrNum`

Tutorials

- “Importing CDF Files”
- “Exporting to CDF Files”

- Purpose** Delete attribute entry
- Syntax** `cdflib.deleteAttrEntry(cdfId,attrNum,entryNum)`
- Description** `cdflib.deleteAttrEntry(cdfId,attrNum,entryNum)` deletes an entry from an attribute in a Common Data Format (CDF) file.
- Input Arguments**
- `cdfId`**
Identifier of a CDF file, returned by a call to `cdflib.create` or `cdflib.open`.
- `attrNum`**
Numeric value that identifies the attribute. Attribute numbers are zero-based. The attribute must have variable scope.
- `entryNum`**
Numeric value that specifies the entry in the attribute. Entry numbers are zero-based.
- Examples** Create a CDF, and then create an attribute in the file. Write a value to an entry for the attribute, and then delete the entry. To run this example, you must be in a writable folder.

```
cdfid = cdflib.create('your_file.cdf');

% Initially the file contains no attributes, global or variable.
info = cdflib.inquire(cdfid)

info =

    encoding: 'IBMPC_ENCODING'
    majority: 'ROW_MAJOR'
    maxRec: -1
    numVars: 0
    numvAttrs: 0
```

cdflib.deleteAttrEntry

```
numgAttrs: 0

% Create an attribute with variable scope in the file.
attrNum = cdflib.createAttr(cdfid,'my_var_scope_attr','variable_scope');

% Write a value to an entry for the attribute
cdflib.putAttrEntry(cdfid,attrNum,0,'CDF_CHAR','My attr value');

% Get the value of the attribute entry
value = cdflib.getAttrEntry(cdfid,attrNum,0)

value =

My attr value

% Delete the entry
cdflib.deleteAttrEntry(cdfid,attrNum,0);

% Now try to view the value of the entry
% Should return NO_SUCH_ENTRY failure.
value = cdflib.getAttrEntry(cdfid,attrNum,0) % Should fail

% Clean up
cdflib.delete(cdfid);

clear cdfid
```

References

This function corresponds to the CDF library C API routine `CDFdeleteAttrzEntry`.

To use this function, you must be familiar with the CDF C interface. Read the CDF documentation at the [CDF Web site](#).

For copyright information, see the `cdfcopyright.txt` file.

See Also

`cdflib.deleteAttr`

Tutorials

- “Importing CDF Files”

- “Exporting to CDF Files”

cdflib.deleteAttrgEntry

Purpose Delete entry in global attribute

Syntax `cdflib.deleteAttrgEntry(cdfId,attrNum,entryNum)`

Description `cdflib.deleteAttrgEntry(cdfId,attrNum,entryNum)` deletes an entry from a global attribute in a Common Data Format (CDF) file.

Input Arguments

`cdfId`
Identifier of a CDF file, returned by a call to `cdflib.create` or `cdflib.open`.

`attrNum`
Numeric value that identifies the attribute. Attribute numbers are zero-based. The attribute must have global scope.

`entryNum`
Numeric value that specifies the entry in the attribute. Entry numbers are zero-based.

Examples Create a CDF and create a global attribute in the file. Write a value to an entry for the attribute and then delete the entry. To run this example, you must be in a writable folder.

```
cdfid = cdflib.create('your_file.cdf');

% Initially the file contains no attributes, global or variable.
info = cdflib.inquire(cdfid)

info =

    encoding: 'IBMPC_ENCODING'
    majority: 'ROW_MAJOR'
    maxRec: -1
    numVars: 0
    numvAttrs: 0
```

```
numgAttrs: 0

% Create an attribute with global scope in the file.
attrNum = cdflib.createAttr(cdfid,'my_global_attr','global_scope');

% Write a value to an entry for the attribute
cdflib.putAttrgEntry(cdfid,attrNum,0,'CDF_CHAR','My global attr');

% Get the value of the global attribute entry
value = cdflib.getAttrgEntry(cdfid,attrNum,0)

value =

My global attr

% Delete the entry
cdflib.deleteAttrgEntry(cdfid,attrNum,0);

% Now try to view the value of the entry
% Should return NO_SUCH_ENTRY failure.
value = cdflib.getAttrgEntry(cdfid,attrNum,0) % Should fail

% Clean up
cdflib.delete(cdfid);

clear cdfid
```

References

This function corresponds to the CDF library C API routine `CDFdeleteAttrgEntry`.

To use this function, you must be familiar with the CDF C interface. Read the CDF documentation at the [CDF Web site](#).

For copyright information, see the `cdfcopyright.txt` file.

See Also

`cdflib.deleteAttr` | `cdflib.deleteAttrEntry`

Tutorials

- “Importing CDF Files”

cdflib.deleteAttrgEntry

- “Exporting to CDF Files”

Purpose Delete variable

Syntax `cdflib.deleteVar(cdfId,varNum)`

Description `cdflib.deleteVar(cdfId,varNum)` deletes a variable from a Common Data Format (CDF) file.

`cdfId` identifies the CDF file. `varNum` is a numeric value that specifies the variable. Variable numbers are zero-based.

Examples Create a CDF, create a variable in the CDF, and then delete it.

```
cdfid = cdflib.create('mycdf.cdf');

% Initially the file contains no variables.
info = cdflib.inquire(cdfid)

info =

    encoding: 'IBMPC_ENCODING'
    majority: 'ROW_MAJOR'
    maxRec: -1
    numVars: 0
    numvAttrs: 0
    numgAttrs: 0

% Create a variable in the CDF.
varNum = cdflib.createVar(cdfid,'Time','cdf_int1',1,[],true,[]);

% Retrieve info about the variable in the CDF.

info = cdflib.inquireVar(cdfid, 0)

info =

    name: 'Time'
    datatype: 'cdf_int1'
```

cdflib.deleteVar

```
        numElements: 1
            dims: []
        recVariance: 1
        dimVariance: []

% Delete the variable from the CDF

cdflib.deleteVar(cdfid,0);

% Check to see if the variable was deleted from the CDF.
info = cdflib.inquire(cdfid)

info =

        encoding: 'IBMPC_ENCODING'
        majority: 'ROW_MAJOR'
            maxRec: -1
        numVars: 0
        numVAttrs: 0
        numGAttrs: 0

% Clean up
cdflib.delete(cdfid);

clear cdfid
```

References

This function corresponds to the CDF library C API routine `CDFdeletezVar`.

To use this function, you must be familiar with the CDF C interface. Read the CDF documentation at the [CDF Web site](#).

For copyright information, see the `cdfcopyright.txt` file.

See Also

`cdflib.createVar`

Tutorials

- “Importing CDF Files”

- “Exporting to CDF Files”

cdflib.deleteVarRecords

Purpose Delete range of records from variable

Syntax `cdflib.deleteVarRecords(cdfId,varNum,startRec,endRec)`

Description `cdflib.deleteVarRecords(cdfId,varNum,startRec,endRec)` deletes a range of records from a variable in a Common Data Format (CDF) file.

Input Arguments

`cdfId`
Identifier of a CDF file, returned by a call to `cdflib.create` or `cdflib.open`.

`varNum`
Numeric value that identifies the variable. Variable numbers are zero-based.

`startRec`
Numeric value that specifies the record at which to start deleting records. Record numbers are zero-based.

`endRec`
Numeric value that specifies the record at which to stop deleting records. Record numbers are zero-based.

Examples Make a writable copy of the example CDF, get the number of a variable in the CDF, and delete specific records in the variable. To run this example, you must be in a writable folder.

```
srcFile = fullfile(matlabroot,'toolbox','matlab','demos','example.cdf');
copyfile(srcFile,'myfile.cdf');
fileattrib('myfile.cdf','+w');
cdfid = cdflib.open('myfile.cdf');
varnum = cdflib.getVarNum(cdfid,'Temperature');
cdflib.deleteVarRecords(cdfid,varnum,1,2);
cdflib.close(cdfid);
```

References

This function corresponds to the CDF library C API routine `CDFdeletezVarRecords`.

To use this function, you must be familiar with the CDF C interface. Read the CDF documentation at the [CDF Web site](#).

For copyright information, see the `cdfcopyright.txt` file.

See Also

`cdflib.getVarNumRecsWritten` | `cdflib.putVarRecordData`

Tutorials

- “Importing CDF Files”
- “Exporting to CDF Files”

cdflib.epoch16Breakdown

Purpose Convert CDF_EPOCH16 value to time value

Syntax `timeVec = cdflib.epoch16Breakdown(epoch16Time)`

Description `timeVec = cdflib.epoch16Breakdown(epoch16Time)` convert a CDF_EPOCH16 value into a time vector. `timeVec` will have 10-by-*n* elements, where *n* is the number of CDF_EPOCH16 values.

The following table describes the time value components.

timeVec Element	Description	Valid Values
<code>timeVec(1,:)</code>	Year AD	e.g. 1994
<code>timeVec(2,:)</code>	Month	1 12
<code>timeVec(3,:)</code>	Day	1 31
<code>timeVec(4,:)</code>	Hour	0 23
<code>timeVec(5,:)</code>	Minute	0 59
<code>timeVec(6,:)</code>	Second	0 59
<code>timeVec(7,:)</code>	Millisecond	0 999
<code>timeVec(8,:)</code>	Microsecond	0 999
<code>timeVec(9,:)</code>	Nanosecond	0 999
<code>timeVec(10,:)</code>	Picosecond	0 999

Examples Convert CDF_EPOCH16 value into time value.

```
timeval = [1999; 12; 31; 23; 59; 59; 50; 100; 500; 999];  
epoch16 = cdflib.computeEpoch16(timeval);
```

```
timevec = cdflib.epoch16Breakdown(epoch16)
```

```
timevec =
```

```
1999
```

12
31
23
59
59
50
100
500
999

References

This function corresponds to the CDF library C API routine `EPOCH16breakdown`.

To use this function, you must be familiar with the CDF C interface. Read the CDF documentation at the [CDF Web site](#).

For copyright information, see the `cdfcopyright.txt` file.

See Also

`cdflib.computeEpoch16`

Tutorials

- “Importing CDF Files”
- “Exporting to CDF Files”

cdflib.epochBreakdown

Purpose Convert CDF_EPOCH value into time value

Syntax `timeVec = cdflib.epochBreakdown(epochTime)`

Description `timeVec = cdflib.epochBreakdown(epochTime)` decomposes the CDF_EPOCH value, epochTime value into individual time components. timeVec will have 7-by-*n* elements, where *n* is the number of CDF_EPOCH values in epochTime.

The return value timeVec has the following elements:

timeVec Element	Description	Valid Values
timeVec(1,:)	Year AD	e.g. 1994
timeVec(2,:)	Month	1 12
timeVec(3,:)	Day	1 31
timeVec(4,:)	Hour	0 23
timeVec(5,:)	Minute	0 59
timeVec(6,:)	Second	0 59
timeVec(7,:)	Millisecond	0 999

Examples

Convert a CDF_EPOCH value into a time vector.

```
% First convert a time vector into a CDF_EPOCH value
timeval = [1999 12 31 23 59 59 0];
epoch = cdflib.computeEpoch(timeval);
```

```
% Convert the CDF_EPOCH value into a time vector
timevec = cdflib.epochBreakdown(epoch)
```

```
timevec =
    1999
         12
         31
```

23
59
59
0

References

This function corresponds to the CDF library C API routine EPOCHbreakdown.

To use this function, you must be familiar with the CDF C interface. Read the CDF documentation at the [CDF Web site](#).

For copyright information, see the `cdfcopyright.txt` file.

See Also

`cdflib.computeEpoch` | `cdflib.epochBreakdown` |
`cdflib.epoch16Breakdown`

Tutorials

- “Importing CDF Files”
- “Exporting to CDF Files”

cdflib.getAttrEntry

Purpose	Value of entry in attribute with variable scope
Syntax	<code>value = cdflib.getAttrEntry(cdfId,attrNum,entryNum)</code>
Description	<code>value = cdflib.getAttrEntry(cdfId,attrNum,entryNum)</code> returns the value of an attribute entry in a Common Data Format (CDF) file.
Input Arguments	<p><code>cdfId</code> Identifier of a CDF file, returned by a call to <code>cdflib.create</code> or <code>cdflib.open</code>.</p> <p><code>attrNum</code> Numeric value that identifies the attribute. Attribute numbers are zero-based. The attribute must have variable scope.</p> <p><code>entryNum</code> Numeric value that specifies the entry in the attribute. Entry numbers are zero-based.</p>
Output Arguments	<p>Value Value of the entry.</p>
Examples	<p>Open the example CDF and get the value of an entry associated with an attribute with variable scope in the file.</p> <pre>cdfid = cdflib.open('example.cdf'); % The fourth attribute is of variable scope. attrscope = cdflib.getAttrScope(cdfid,3) attrscope = VARIABLE_SCOPE</pre>

```
% Get information about the first entry for this attribute
[dtype numel] = cdflib.inquireAttrEntry(cdfid,3,0)

dtype =

cdf_char

numel =

    10

% Get the value of the entry for this attribute.
% Note that it's a character string, 10 characters in length
value = cdflib.getAttrEntry(cdfid,3,0)

value =

Time value

% Clean up
cdflib.close(cdfid);

clear cdfid
```

References

This function corresponds to the CDF library C API routine `CDFgetAttrzEntry`.

To use this function, you must be familiar with the CDF C interface. Read the CDF documentation at the [CDF Web site](#).

For copyright information, see the `cdfcopyright.txt` file.

See Also

`cdflib.putAttrEntry` | `cdflib.getAttrEntry` |
`cdflib.putAttrEntry`

Tutorials

- “Importing CDF Files”

cdflib.getAttrEntry

- “Exporting to CDF Files”

Purpose	Value of entry in global attribute
Syntax	<code>value = cdflib.getAttrgEntry(cdfId,attrNum,entryNum)</code>
Description	<code>value = cdflib.getAttrgEntry(cdfId,attrNum,entryNum)</code> returns the value of a global attribute entry in a Common Data Format (CDF) file.
Input Arguments	<p><code>cdfId</code> Identifier of a CDF file, returned by a call to <code>cdflib.create</code> or <code>cdflib.open</code>.</p> <p><code>attrNum</code> Numeric value that identifies the attribute. Attribute numbers are zero-based. The attribute must have global scope.</p> <p><code>entryNum</code> Numeric value that specifies the entry in the attribute. Entry numbers are zero-based.</p>
Output Arguments	<p><code>Value</code> Value of the entry.</p>
Examples	<p>Open the example CDF, and then get the value of an entry associated with a global attribute in the file:</p> <pre>cdfid = cdflib.open('example.cdf'); % Any of the first three attributes have global scope. attrscope = cdflib.getAttrScope(cdfid,0) attrscope = GLOBAL_SCOPE</pre>

cdflib.getAttrgEntry

```
% Get information about the first entry for global attribute
[dtype numel] = cdflib.inquireAttrgEntry(cdfid,0,0)

dtype =

cdf_char

numel =

    23

% Get the value of the first entry for this global attribute.
value = cdflib.getAttrgEntry(cdfid,0,0)

value =

This is a sample entry.

% Clean up
cdflib.close(cdfid);

clear cdfid
```

References

This function corresponds to the CDF library C API routine `CDFgetAttrgEntry`.

To use this function, you must be familiar with the CDF C interface. Read the CDF documentation at the [CDF Web site](#).

For copyright information, see the `cdfcopyright.txt` file.

See Also

`cdflib.putAttrgEntry` | `cdflib.getAttrEntry` |
`cdflib.putAttrEntry`

Tutorials

- “Importing CDF Files”

- “Exporting to CDF Files”

cdflib.getAttrMaxEntry

Purpose Number of last entry for variable attribute

Syntax `maxEntry = cdflib.getAttrMaxEntry(cdfId,attrNum)`

Description `maxEntry = cdflib.getAttrMaxEntry(cdfId,attrNum)` returns the number of the last entry for an attribute in a Common Data Format (CDF) file.

`cdfId` identifies the CDF file.

`attrNum` is a numeric value that specifies the attribute. Attribute numbers are zero-based. The attribute must have variable scope.

Input Arguments

cdfId

Identifier of a CDF file, returned by a call to `cdflib.create` or `cdflib.open`.

attrNum

Numeric value that identifies the attribute. Attribute numbers are zero-based. The attribute must have variable scope.

Output Arguments

maxEntry

Entry number of the last entry in the attribute. Entry numbers are zero-based.

Examples

Open the example CDF and get the number of the last entry associated with an attribute with variable scope in the file:

```
cdfid = cdflib.open('example.cdf');  
  
% The fourth attribute is of variable scope.  
attrscope = cdflib.getAttrScope(cdfid,3)  
  
attrscope =  
  
VARIABLE_SCOPE
```

```
% Get the number of the last entry for this attribute.
entrynum = cdflib.getAttrMaxEntry(cdfid,3)

entrynum =

    3

% Clean up
cdflib.close(cdfid);

clear cdfid
```

References

This function corresponds to the CDF library C API routine `CDFgetAttrMaxEntry`.

To use this function, you must be familiar with the CDF C interface. Read the CDF documentation at the [CDF Web site](#).

For copyright information, see the `cdfcopyright.txt` file.

See Also

`cdflib.getAttrMaxgEntry`

Tutorials

- “Importing CDF Files”
- “Exporting to CDF Files”

cdflib.getAttrMaxgEntry

Purpose	Number of last entry for global attribute
Syntax	<code>maxEntry = cdflib.getAttrMaxgEntry(cdfId,attrNum)</code>
Description	<code>maxEntry = cdflib.getAttrMaxgEntry(cdfId,attrNum)</code> returns the last entry number of a global attribute in a Common Data Format (CDF) file.
Input Arguments	<p><code>cdfId</code> Identifier of a CDF file, returned by a call to <code>cdflib.create</code> or <code>cdflib.open</code>.</p> <p><code>attrNum</code> Numeric value that identifies the attribute. Attribute numbers are zero-based. The attribute must have global scope.</p>
Output Arguments	<p><code>maxEntry</code> Entry number of the last entry in the attribute. Entry numbers are zero-based.</p>
Examples	<p>Open the example CDF and get the number of the last entry associated with a global attribute in the file:</p> <pre>cdfid = cdflib.open('example.cdf'); % Any of the first three attribute are of global scope. attrscope = cdflib.getAttrScope(cdfid,0) attrscope = GLOBAL_SCOPE % Get the number of the last entry for this attribute. entrynum = cdflib.getAttrMaxgEntry(cdfid,0)</pre>

```
entrynum =  
    4  
  
% Clean up  
cdflib.close(cdfid);  
  
clear cdfid
```

References

This function corresponds to the CDF library C API routine `CDFgetAttrMaxgEntry`.

To use this function, you must be familiar with the CDF C interface. Read the CDF documentation at the [CDF Web site](#).

For copyright information, see the `cdfcopyright.txt` file.

See Also

`cdflib.getAttrMaxEntry`

Tutorials

- “Importing CDF Files”
- “Exporting to CDF Files”

cdflib.getAttrName

Purpose Name of attribute, given attribute number

Syntax `name = cdflib.getAttrName(cdfId,attrNum)`

Description `name = cdflib.getAttrName(cdfId,attrNum)` returns the name of an attribute in a Common Data Format (CDF) file.

Input Arguments

`cdfid`
Identifier of a CDF file, returned by a call to `cdflib.create` or `cdflib.open`.

`attrNum`
Numeric value that identifies the attribute. Attribute numbers are zero-based.

Output Arguments

`name`
Text string specifying the name of the attribute.

Examples Open the example CDF and get name of an attribute.

```
cdfid = cdflib.open('example.cdf');

% Get name of the first attribute in the file.
attrName = cdflib.getAttrName(cdfid,0)

attrName =

SampleAttribute

% Clean up
cdflib.close(cdfid);

clear cdfid
```

References

This function corresponds to the CDF library C API routine `CDFgetAttrName`.

To use this function, you must be familiar with the CDF C interface. Read the CDF documentation at the [CDF Web site](#).

For copyright information, see the `cdfcopyright.txt` file.

See Also

`cdflib.createAttr`

Tutorials

- “Importing CDF Files”
- “Exporting to CDF Files”

cdflib.getAttrNum

Purpose	Attribute number, given attribute name
Syntax	<code>attrNum = cdflib.getAttrNum(cdfId,attrName)</code>
Description	<code>attrNum = cdflib.getAttrNum(cdfId,attrName)</code> returns the number of an attribute in a Common Data Format (CDF) file.
Input Arguments	<code>cdfId</code> Identifier of a CDF file, returned by a call to <code>cdflib.create</code> or <code>cdflib.open</code> . <code>attrName</code> Text string specifying the name of an attribute.
Output Arguments	<code>attrNum</code> Numeric value that identifies the attribute. Attribute numbers are zero-based.
Examples	Open the example CDF and get the attribute number associated with the <code>SampleAttribute</code> attribute. <pre>cdfid = cdflib.open('example.cdf'); attrNum = cdflib.getAttrNum(cdfid,'SampleAttribute') attrNum = 0 % Clean up cdflib.close(cdfid); clear cdfid</pre>

References

This function corresponds to the CDF library C API routine `CDFgetAttrNum`.

To use this function, you must be familiar with the CDF C interface. Read the CDF documentation at the [CDF Web site](#).

For copyright information, see the `cdfcopyright.txt` file.

See Also

`cdflib.createAttr` | `cdflib.getAttrName`

Tutorials

- “Importing CDF Files”
- “Exporting to CDF Files”

cdflib.getAttrScope

Purpose Scope of attribute

Syntax `scope = cdflib.getAttrScope(cdfId,attrNum)`

Description `scope = cdflib.getAttrScope(cdfId,attrNum)` returns the scope of an attribute in a Common Data Format (CDF) file.

Input Arguments

cdfid
Identifier of a CDF file, returned by a call to `cdflib.create` or `cdflib.open`.

attrNum
Numeric value that specifies the attribute. Attribute numbers are zero-based.

Output Arguments

scope
Either of the following text strings, or its numeric equivalent.

Text String	Description
'GLOBAL_SCOPE'	Attribute applies to the CDF as a whole.
'VARIABLE_SCOPE'	Attribute applies only to the variable.

To get the numeric equivalent of these text string constants, use the `cdflib.getConstantValue` function.

Examples Open example CDF and get the scope of the first attribute in the file:

```
cdfid = cdflib.open('example.cdf');  
  
attrScope = cdflib.getAttrScope(cdfid,0)  
  
attrScope =
```

```
GLOBAL_SCOPE

% Clean up
cdflib.close(cdfid);

clear cdfid
```

References

This function corresponds to the CDF library C API routine `CDFgetAttrScope`.

To use this function, you must be familiar with the CDF C interface. Read the CDF documentation at the [CDF Web site](#).

For copyright information, see the `cdfcopyright.txt` file.

See Also

`cdflib.createAttr` | `cdflib.getAttrName` |
`cdflib.getConstantValue`

Tutorials

- “Importing CDF Files”
- “Exporting to CDF Files”

cdflib.getCacheSize

Purpose Number of cache buffers used

Syntax `numBuffers = cdflib.getCacheSize(cdfId)`

Description `numBuffers = cdflib.getCacheSize(cdfId)` returns the number of cache buffers used for the Common Data Format (CDF) file identified by `cdfId`. For a discussion of cache schemes, see the *CDF User's Guide*.

Examples Open the example CDF file and get the cache size:

```
cdfid = cdflib.open('example.cdf');  
  
numBuf = cdflib.getCacheSize(cdfid)  
  
numBuf =  
  
      300  
  
% Clean up  
cdflib.close(cdfid)  
clear cdfid
```

References This function corresponds to the CDF library C API routine `CDFgetCacheSize`.

To use this function, you must be familiar with the CDF C interface. Read the CDF documentation at the [CDF Web site](#).

For copyright information, see the `cdfcopyright.txt` file.

See Also `cdflib.setCacheSize`

Tutorials • “Importing CDF Files”
 • “Exporting to CDF Files”

Purpose Checksum mode

Syntax `mode = cdflib.getChecksum(cdfId)`

Description `mode = cdflib.getChecksum(cdfId)` returns the checksum mode of the Common Data Format (CDF) file.

Input Arguments **cdfid**
Identifier of a CDF file, returned by a call to `cdflib.create` or `cdflib.open`.

Output Arguments **mode**
Either of the following text strings or its numeric equivalent.

'MD5_CHECKSUM'	File uses MD5 checksum.
'NO_CHECKSUM'	File does not use a checksum.

To get the numeric equivalent of these text strings, use `cdflib.getConstantValue`.

Examples Open the example CDF file, and then get the checksum mode of the file:

```
cdfid = cdflib.open('example.cdf');  
  
checksummode = cdflib.getChecksum(cdfid)  
  
checksummode =  
  
NO_CHECKSUM  
  
% Clean up  
cdflib.close(cdfid);  
clear cdfid;
```

cdflib.getChecksum

References

This function corresponds to the CDF library C API routine `CDFgetChecksum`.

To use this function, you must be familiar with the CDF C interface. Read the CDF documentation at the [CDF Web site](#).

For copyright information, see the `cdfcopyright.txt` file.

See Also

`cdflib.setChecksum` | `cdflib.getConstantValue`

Tutorials

- “Importing CDF Files”
- “Exporting to CDF Files”

Purpose	Compression settings
Syntax	<code>[ctype, cparms, cpercentage] = cdflib.getCompression(cdfId)</code>
Description	<code>[ctype, cparms, cpercentage] = cdflib.getCompression(cdfId)</code> returns information about the compression settings of a Common Data Format (CDF) file.
Input Arguments	cdfId Identifier of a CDF file, returned by a call to <code>cdflib.create</code> or <code>cdflib.open</code> .
Output Arguments	ctype Text string specifying compression type, such as <code>'HUFF_COMPRESSION'</code> . If the CDF does not use compression, the function returns the string <code>'NO_COMPRESSION'</code> . For a list of supported compression types, see <code>cdflib.setCompression</code> . cparms The value of the parameter associated with the type of compression. For example, for the <code>'RLE_COMPRESSION'</code> compression type, the parameter specifies the style of run-length encoding. For a list of parameters supported by each compression type, see <code>cdflib.setCompression</code> . cpercentage The rate of compression, expressed as a percentage.
Examples	Open the example CDF file and check the compression settings in the file. <pre>cdfId = cdflib.open('example.cdf'); [ctype, cparms, cpercentage] = cdflib.getCompression(cdfId)</pre>

cdflib.getCompression

```
ctype =  
GZIP_COMPRESSION  
cparms =  
    7  
cper =  
    26  
  
% Clean up  
cdflib.close(cdfId)  
clear cdfId
```

References

This function corresponds to the CDF library C API routine `CDFgetCompression`.

To use this function, you must be familiar with the CDF C interface. Read the CDF documentation at the [CDF Web site](#).

For copyright information, see the `cdfcopyright.txt` file.

See Also

`cdflib.setCompression` | `cdflib.getVarCompression` | `cdflib.setVarCompression`

Tutorials

- “Importing CDF Files”
- “Exporting to CDF Files”

Purpose	Number of compression cache buffers
Syntax	<code>numBuffers = cdflib.getCompressionCacheSize(cdfId)</code>
Description	<code>numBuffers = cdflib.getCompressionCacheSize(cdfId)</code> returns the number of cache buffers used for the compression scratch Common Data Format (CDF) file. <code>cdfId</code> identifies the CDF file. For a discussion of cache schemes, see the <i>CDF User's Guide</i> .
Examples	<p>Open the example CDF file and check the compression cache size of the file:</p> <pre>cdfId = cdflib.open('example.cdf'); numBuf = cdflib.getCompressionCacheSize(cdfId) numBuf = 80 % Clean up cdflib.close(cdfId) clear cdfId</pre>
References	<p>This function corresponds to the CDF library C API routine <code>CDFgetCompressionCacheSize</code>.</p> <p>To use this function, you must be familiar with the CDF C interface. Read the CDF documentation at the CDF Web site.</p> <p>For copyright information, see the <code>cdfcopyright.txt</code> file.</p>
See Also	<code>cdflib.setCompressionCacheSize</code>
Tutorials	<ul style="list-style-type: none">• “Importing CDF Files”• “Exporting to CDF Files”

cdflib.getConstantNames

Purpose Names of Common Data Format (CDF) library constants

Syntax `names = cdflib.getConstantNames()`

Description `names = cdflib.getConstantNames()` returns a cell array of text strings, where each text string is the name of a constant known to the Common Data Format (CDF) library.

Examples Get a list of the names of CDF library constants.

```
names = cdflib.getConstantNames()
```

```
names =  
  
    'AHUFF_COMPRESSION'  
    'ALPHAMVSD_ENCODING'  
    'ALPHAMVSG_ENCODING'  
    'ALPHAMVSI_ENCODING'  
    'ALPHAOSF1_ENCODING'  
    'CDF_BYTE'  
    'CDF_CHAR'  
    .  
    .  
    .
```

References For copyright information, see the `cdfcopyright.txt` file.

See Also `cdflib.getConstantValue`

Tutorials

- “Importing CDF Files”
- “Exporting to CDF Files”

Purpose Numeric value corresponding to Common Data Format (CDF) library constant

Syntax `value = cdflib.getConstantValue(constantName)`

Description `value = cdflib.getConstantValue(constantName)` returns the numeric value of the CDF library constant specified by the text string *constantName*. To see a list of constant names, use `cdflib.getConstantNames`.

Examples View the list of CDF library constants and get the numeric value corresponding to one of the constants.

```
% Retrieve a list of library constants
names = cdflib.getConstantNames();

value = cdflib.getConstantValue(names{1})

value =

    3
```

References For copyright information, see the `cdfcopyright.txt` file.

See Also `cdflib.getConstantNames`

Tutorials

- “Importing CDF Files”
- “Exporting to CDF Files”

cdflib.getCopyright

Purpose Copyright notice in Common Data Format (CDF) file

Syntax `copyright = cdflib.getCopyright(cdfId)`

Description `copyright = cdflib.getCopyright(cdfId)` returns the copyright notice in the CDF file identified by `cdfId`.

Examples Create a CDF file, and then get the copyright notice in the file. To run this example, you must be in a writable folder.

```
cdfId = cdflib.create('your_file.cdf');  
  
copyright = cdflib.getCopyright(cdfId)  
  
copyright =  
  
Common Data Format (CDF)  
(C) Copyright 1990-2009 NASA/GSFC  
Space Physics Data Facility  
NASA/Goddard Space Flight Center  
Greenbelt, Maryland 20771 USA  
(Internet -- CDFSUPPORT@LISTSERV.GSFC.NASA.GOV)  
  
% Clean up.  
cdflib.delete(cdfId)  
clear cdfId
```

References This function corresponds to the CDF library C API routine `CDFgetCopyright`.

To use this function, you must be familiar with the CDF C interface. Read the CDF documentation at the [CDF Web site](#).

For copyright information, see the `cdfcopyright.txt` file.

See Also `cdflib.getLibraryCopyright`

Tutorials

- “Importing CDF Files”
- “Exporting to CDF Files”

cdflib.getFileBackward

Purpose Return current backward compatibility mode setting

Syntax `mode = cdflib.getFileBackward()`

Description `mode = cdflib.getFileBackward()` returns the backward compatibility mode.

Output Arguments **mode**
One of the following text strings:

BACKWARDFILEon	Backward compatibility mode is on.
BACKWARDFILEoff	Backward compatibility mode is off.

For more information about backward compatibility mode, see `cdflib.setFileBackward`.

Examples

```
mode = cdflib.getFileBackward  
  
mode =  
  
BACKWARDFILEoff
```

References This function corresponds to the CDF library C API routine `CDFgetFileBackward`.

To use this function, you must be familiar with the CDF C interface. Read the CDF documentation at the [CDF Web site](#).

For copyright information, see the `cdfcopyright.txt` file.

See Also `cdflib.setFileBackward` | `cdflib.getConstantValue`

Tutorials

- “Importing CDF Files”
- “Exporting to CDF Files”

Purpose Format of Common Data Format (CDF) file

Syntax `format = cdflib.setFormat(cdfId)`

Description `format = cdflib.setFormat(cdfId)` returns the format of the CDF file.

Input Arguments **`cdfId`**
Identifier of a CDF file, returned by a call to `cdflib.create` or `cdflib.open`.

Output Arguments **`format`**
Either of the following text strings, or its numeric equivalent.

'SINGLE_FILE'	The CDF is stored in a single file.
'MULTI_FILE'	The CDF is made up of multiple files.

To get the numeric equivalent of these text strings, use `cdflib.getConstantValue`.

Examples Open the example CDF file and determine its file format:

```
cdfId = cdflib.open('example.cdf');  
  
format = cdflib.getFormat(cdfId)  
  
format =  
  
    'SINGLE_FILE'  
  
% Clean up.  
cdflib.close(cdfId)  
clear cdfId
```

cdflib.getFormat

References

This function corresponds to the CDF library C API routine `CDFgetFormat`.

To use this function, you must be familiar with the CDF C interface. Read the CDF documentation at the [CDF Web site](#).

For copyright information, see the `cdfcopyright.txt` file.

See Also

`cdflib.setFormat` | `cdflib.getConstantValue`

Tutorials

- “Importing CDF Files”
- “Exporting to CDF Files”

Purpose	Copyright notice of Common Data Format (CDF) library
Syntax	<pre>copyright = cdflib.getLibraryCopyright()</pre>
Description	<pre>copyright = cdflib.getLibraryCopyright()</pre> returns a text string containing the copyright notice of the CDF library.
Examples	<p>Get the copyright of the CDF library.</p> <pre>copyright = cdflib.getLibraryCopyright() copyright = Common Data Format (CDF) (C) Copyright 1990-2008 NASA/GSFC Space Physics Data Facility NASA/Goddard Space Flight Center Greenbelt, Maryland 20771 USA (Internet -- CDFSUPPORT@LISTSERV.GSFC.NASA.GOV)</pre>
References	<p>This function corresponds to the CDF library C API routine <code>CDFgetLibraryCopyright</code>.</p> <p>To use this function, you must be familiar with the CDF C interface. Read the CDF documentation at the CDF Web site.</p> <p>For copyright information, see the <code>cdfcopyright.txt</code> file.</p>
See Also	<code>cdflib.getCopyright</code>
Tutorials	<ul style="list-style-type: none">• “Importing CDF Files”• “Exporting to CDF Files”

cdflib.getLibraryVersion

Purpose	Library version and release information
Syntax	<code>[version,release,increment] = cdflib.getLibraryVersion()</code>
Description	<code>[version,release,increment] = cdflib.getLibraryVersion()</code> returns information about the Common Data Format (CDF) library.
Output Arguments	version Numeric value indicating the version number of the CDF library. release Numeric value indicating the release number of the CDF library. increment Numeric value indicating the increment number of the CDF library.
Examples	Get the version information of the CDF library: <pre>[version, release, increment] = cdflib.getLibraryVersion() version = 3 release = 3 increment = 0</pre>
References	This function corresponds to the CDF library C API routine <code>CDFgetLibraryVersion</code> .

To use this function, you must be familiar with the CDF C interface. Read the CDF documentation at the [CDF Web site](#).

For copyright information, see the `cdfcopyright.txt` file.

See Also

`cdflib.getVersion`

Tutorials

- “Importing CDF Files”
- “Exporting to CDF Files”

cdflib.getMajority

Purpose Majority of variables

Syntax `majority = cdflib.getMajority(cdfId)`

Description `majority = cdflib.getMajority(cdfId)` returns the majority of variables in a Common Data Format (CDF) file.

Input Arguments **`cdfId`**
Identifier of a CDF file, returned by a call to `cdflib.create` or `cdflib.open`.

Output Arguments **`majority`**
Either of the following text strings, or its numeric equivalent.

'ROW_MAJOR'	C-like array ordering for variable storage. The first dimension in each variable array varies the slowest. This is the default.
'COLUMN_MAJOR'	Fortran-like array ordering for variable storage. The first dimension in each variable array varies the fastest.

To get the numeric equivalent of these values, use `cdflib.getConstantValue`.

Examples Open the example CDF file, and then determine the majority of variables in the file:

```
cdfId = cdflib.open('example.cdf');  
  
majority = cdflib.getMajority(cdfId)  
  
majority =  
  
ROW_MAJOR
```

```
% Clean up
cdflib.close(cdfId)

clear cdfId
```

References

This function corresponds to the CDF library C API routine `CDFgetMajority`.

To use this function, you must be familiar with the CDF C interface. Read the CDF documentation at the [CDF Web site](#).

For copyright information, see the `cdfcopyright.txt` file.

See Also

`cdflib.setMajority` | `cdflib.getConstantValue`

Tutorials

- “Importing CDF Files”
- “Exporting to CDF Files”

cdflib.getName

Purpose Name of Common Data Format (CDF) file

Syntax `name = cdflib.getName(cdfId)`

Description `name = cdflib.getName(cdfId)` returns the name of the CDF file identified by `cdfId`.

Examples Open the example CDF file and get the name of the file. The path name returned for your installation will be different.

```
cdfId = cdflib.open('example.cdf');  
  
name = cdflib.getName(cdfId)  
  
name =  
  
yourinstallation\matlab\toolbox\matlab\demos\example  
  
% Clean up  
cdflib.close(cdfId)  
  
clear cdfId
```

References This function corresponds to the CDF library C API routine `CDFgetName`.

To use this function, you must be familiar with the CDF C interface. Read the CDF documentation at the [CDF Web site](#).

For copyright information, see the `cdfcopyright.txt` file.

See Also `cdflib.open` | `cdflib.create`

Tutorials

- “Importing CDF Files”
- “Exporting to CDF Files”

Purpose Number of entries for attribute with variable scope

Syntax `nentries = cdflib.getNumAttrEntries(cdfId,attrNum)`

Description `nentries = cdflib.getNumAttrEntries(cdfId,attrNum)` returns the number of entries for the specified attribute in the Common Data Format (CDF) file.

`cdfId` identifies the CDF file.

`attrNum` is a numeric value that specifies the attribute. Attribute numbers are zero-based. The attribute must have variable scope.

Examples Open the example CDF, find an attribute with variable scope, and determine how many entries are associated with the attribute:

```
cdfid = cdflib.open('example.cdf');

% Get the number of an attribute
% with variable scope
attrNum = cdflib.getAttrNum(cdfid,'Description');

% Check that scope of attribute is variable
attrScope = cdflib.getAttrScope(cdfid,attrNum)

VARIABLE_SCOPE

% Determine the number of entries for the attribute
attrEntries = cdflib.getNumAttrEntries(cdfid,attrNum)

attrEntries =

    4

% Clean up
cdflib.close(cdfid);
```

cdflib.getNumAttrEntries

References

This function corresponds to the CDF library C API routine `CDFgetNumAttrzEntries`.

To use this function, you must be familiar with the CDF C interface. Read the CDF documentation at the [CDF Web site](#).

For copyright information, see the `cdfcopyright.txt` file.

See Also

`cdflib.getAttrScope`

Tutorials

- “Importing CDF Files”
- “Exporting to CDF Files”

Purpose

Number of entries for attribute with global scope

Syntax

```
nentries = cdflib.getNumAttrgEntries(cdfId,attrNum)
```

Description

`nentries = cdflib.getNumAttrgEntries(cdfId,attrNum)` returns the number of entries written for the specified global attribute in the Common Data Format (CDF) file.

`cdfId` identifies the CDF file. `attrNum` is a numeric value that identifies the attribute. Attribute numbers are zero-based. The attribute must have global scope.

Examples

Open the example CDF and find out how many entries are associated with a global attribute in the file.

```
cdfid = cdflib.open('example.cdf');

% The first attribute is a global attribute.
attrgEntries = cdflib.getNumAttrgEntries(cdfid,0)

attrgEntries =

     3

% Clean up
cdflib.close(cdfid);

clear cdfid
```

References

This function corresponds to the CDF library C API routine `CDFgetNumAttrgEntries`.

To use this function, you must be familiar with the CDF C interface. Read the CDF documentation at the [CDF Web site](#).

For copyright information, see the `cdfcopyright.txt` file.

See Also

`cdflib.getNumAttrEntries`

cdflib.getNumAttrgEntries

Tutorials

- “Importing CDF Files”
- “Exporting to CDF Files”

Purpose	Number of attributes with variable scope
Syntax	<code>numAtts = cdflib.getNumAttributes(cdfId)</code>
Description	<code>numAtts = cdflib.getNumAttributes(cdfId)</code> returns the total number of attributes with variable scope in a Common Data Format (CDF) file. <code>cdfId</code> identifies the CDF file.
Examples	<p>Open the example CDF and find out how many attributes in the file have variable scope:</p> <pre>cdfid = cdflib.open('example.cdf'); % Determine the number of attributes with variable scope numAttr = cdflib.getNumAttributes(cdfid) numAttr = 1 % Clean up cdflib.close(cdfid); clear cdfid</pre>
References	<p>This function corresponds to the CDF library C API routine <code>CDFgetNumvAttributes</code>.</p> <p>To use this function, you must be familiar with the CDF C interface. Read the CDF documentation at the CDF Web site.</p> <p>For copyright information, see the <code>cdfcopyright.txt</code> file.</p>
See Also	<code>cdflib.getNumgAttributes</code>
Tutorials	<ul style="list-style-type: none">• “Importing CDF Files”• “Exporting to CDF Files”

cdflib.getNumgAttributes

Purpose Number of attributes with global scope

Syntax `ngatts = cdflib.getNumgAttributes(cdfId)`

Description `ngatts = cdflib.getNumgAttributes(cdfId)` returns the total number of global attributes in a Common Data Format (CDF) file. `cdfId` identifies the CDF file.

Examples Open the example CDF and find out how many global attributes are in the file:

```
cdfid = cdflib.open('example.cdf');

% Determine the number of global attributes in the file.
numgAttrs = cdflib.getNumgAttributes(cdfid)

numgAttrs =

    3

% Clean up
cdflib.close(cdfid);
```

References This function corresponds to the CDF library C API routine `CDFgetNumgAttributes`.

To use this function, you must be familiar with the CDF C interface. Read the CDF documentation at the [CDF Web site](#).

For copyright information, see the `cdfcopyright.txt` file.

See Also `cdflib.getNumAttributes`

Tutorials

- “Importing CDF Files”
- “Exporting to CDF Files”

Purpose Read-only mode

Syntax `mode = cdflib.getReadOnlyMode(cdfId)`

Description `mode = cdflib.getReadOnlyMode(cdfId)` returns the read-only mode of a Common Data Format (CDF) file.

Input Arguments **`cdfId`**
Identifier of a CDF file, returned by a call to `cdflib.create` or `cdflib.open`.

Output Arguments **`mode`**
Either of the following text strings or its numeric equivalent.

'READONLYon'	CDF is in read-only mode
'READONLYoff'	CDF can be modified.

To get the numeric equivalent of these text strings, use `cdflib.getConstantValue`.

Examples Open the example CDF file and determine its current read-only status:

```
cdfId = cdflib.open('example.cdf');  
  
mode = cdflib.getReadOnlyMode(cdfId)  
  
mode =  
  
READONLYoff  
  
% Clean up.  
cdflib.close(cdfId);  
clear cdfId
```

cdflib.getReadOnlyMode

References

This function corresponds to the CDF library C API routine `CDFgetReadOnlyMode`.

To use this function, you must be familiar with the CDF C interface. Read the CDF documentation at the [CDF Web site](#).

For copyright information, see the `cdfcopyright.txt` file.

See Also

`cdflib.setReadOnlyMode` | `cdflib.getConstantValue`

Tutorials

- “Importing CDF Files”
- “Exporting to CDF Files”

Purpose	Number of cache buffers for staging
Syntax	<code>numBuffers = cdflib.getStageCacheSize(cdfId)</code>
Description	<p><code>numBuffers = cdflib.getStageCacheSize(cdfId)</code> returns the number of cache buffers used for the staging scratch file of the Common Data Format (CDF) file. For more information about cache buffers, see the <i>CDF User's Guide</i>.</p> <p><code>cdfId</code> identifies the CDF file.</p>
Examples	<p>Open the example CDF file and determine the number of cache buffers used for staging:</p> <pre>cdfId = cdflib.open('example.cdf'); numBuf = cdflib.getStageCacheSize(cdfId) numBuf = 125 % Clean up cdflib.close(cdfId) clear cdfId</pre>
References	<p>This function corresponds to the CDF library C API routine <code>CDFgetStageCacheSize</code>.</p> <p>To use this function, you must be familiar with the CDF C interface. Read the CDF documentation at the CDF Web site.</p> <p>For copyright information, see the <code>cdfcopyright.txt</code> file.</p>
See Also	<code>cdflib.setStageCacheSize</code>
Tutorials	<ul style="list-style-type: none">• “Importing CDF Files”

cdflib.getStageCacheSize

- “Exporting to CDF Files”

Purpose Library validation mode

Syntax `mode = cdflib.getValidate()`

Description `mode = cdflib.getValidate()` returns the validation mode of the Common Data Format (CDF) library.

Output Arguments **mode**
Either of the following text strings or its numeric equivalent.

'VALIDATEFILEon'	Validation mode is on. For information about validation mode, see <code>cdflib.setValidate</code> .
'VALIDATEFILEoff'	Validation mode is off.

To get the numeric equivalent of these text strings, use `cdflib.getConstantValue`.

Examples Determine the current validation mode of the CDF library.

```
mode = cdflib.getValidate()
```

```
mode =
```

```
'VALIDATEFILEon'
```

References This function corresponds to the CDF library C API routine `CDFgetValidate`.

To use this function, you must be familiar with the CDF C interface. Read the CDF documentation at the [CDF Web site](#).

For copyright information, see the `cdfcopyright.txt` file.

See Also `cdflib.setValidate` | `cdflib.getConstantValue`

Tutorials • “Importing CDF Files”

cdflib.getValidate

- “Exporting to CDF Files”

Purpose	Number of records allocated for variable
Syntax	<code>numrecs = cdflib.getVarAllocRecords(cdfId, varNum)</code>
Description	<p><code>numrecs = cdflib.getVarAllocRecords(cdfId, varNum)</code> returns the number of records allocated for a variable in a Common Data Format (CDF) file.</p> <p><code>cdfId</code> identifies the CDF file. <code>varNum</code> is a numeric value that identifies the variable. Variable numbers are zero-based.</p>
Examples	<p>Open example CDF and get the number of records allocated for a variable:</p> <pre>cdfid = cdflib.open('example.cdf'); % Determine the number of records allocated for the % first variable in the file. numrecs = cdflib.getVarAllocRecords(cdfid,0) numrecs = 64 % Clean up cdflib.close(cdfid) clear cdfid</pre>
References	<p>This function corresponds to the CDF library C API routine <code>CDFgetzVarAllocRecords</code>.</p> <p>To use this function, you must be familiar with the CDF C interface. Read the CDF documentation at the CDF Web site.</p> <p>For copyright information, see the <code>cdfcopyright.txt</code> file.</p>

cdflib.getVarAllocRecords

See Also

`cdflib.setVarAllocBlockRecords`

Tutorials

- “Importing CDF Files”
- “Exporting to CDF Files”

Purpose	Blocking factor for variable
Syntax	<code>blockingFactor = cdflib.getVarBlockingFactor(cdfId,varNum)</code>
Description	<p><code>blockingFactor = cdflib.getVarBlockingFactor(cdfId,varNum)</code> returns the blocking factor for a variable in a Common Data Format (CDF) file. A variable's <i>blocking factor</i> specifies the minimum number of records the library allocates when you write to an unallocated record. <code>cdfId</code> identifies the CDF file. <code>varNum</code> is a numeric value that identifies the variable. Variable numbers are zero-based.</p>
Examples	<p>Open the example CDF and determine the blocking factor of a variable.</p> <pre>cdfid = cdflib.open('example.cdf'); cdflib.getVarBlockingFactor(cdfid,0) ans = 0 % Clean up cdflib.close(cdfid) clear cdfid</pre>
References	<p>This function corresponds to the CDF library C API routine <code>CDFgetzVarBlockingFactor</code>.</p> <p>To use this function, you must be familiar with the CDF C interface. Read the CDF documentation at the CDF Web site.</p> <p>For copyright information, see the <code>cdfcopyright.txt</code> file.</p>
See Also	<code>cdflib.setVarBlockingFactor</code>
Tutorials	<ul style="list-style-type: none">• “Importing CDF Files”

cdflib.getVarBlockingFactor

- “Exporting to CDF Files”

Purpose

Number of multifile cache buffers

Syntax

```
numBuffers = cdflib.getVarCacheSize(cdfId,varNum)
```

Description

`numBuffers = cdflib.getVarCacheSize(cdfId,varNum)` returns the number of cache buffers used for a variable in a Common Data Format (CDF) file.

`cdfId` identifies the CDF file. `varNum` is a numeric value that identifies the variable. Variable identifiers are zero-based.

This function applies only to multifile format CDFs. For more information about caching, see the *CDF User's Guide*.

Examples

Create a multifile CDF and retrieve the number of buffers being used for a variable. To run this example, you must be in a writable folder.

```
cdfid = cdflib.create('your_file.cdf')

% Set the format of the file to be multi-file
cdflib.setFormat(cdfid,'MULTI_FILE');

% Create a variable in the file
varNum = cdflib.createVar(cdfid,'Time','cdf_int1',1,[],true,[]);

% Note how the library creates a separate file for the variable
ls your_file.*

your_file.cdf  your_file.z0

% Determine the number of cache buffers used with the variable
numBuf = cdflib.getVarCacheSize(cdfid,varNum)

numBuf =

     1

% Clean up
```

cdflib.getVarCacheSize

```
cdflib.delete(cdfid);
```

```
clear cdfid
```

References

This function corresponds to the CDF library C API routine `CDFgetzVarCacheSize`.

To use this function, you must be familiar with the CDF C interface. Read the CDF documentation at the [CDF Web site](#).

For copyright information, see the `cdfcopyright.txt` file.

See Also

```
cdflib.setVarCacheSize
```

Tutorials

- “Importing CDF Files”
- “Exporting to CDF Files”

Purpose	Information about compression used by variable
Syntax	<code>[ctype, cparams, percent] = cdflib.getVarCompression(cdfId, varNum)</code>
Description	<code>[ctype, cparams, percent] = cdflib.getVarCompression(cdfId, varNum)</code> returns information about the compression used for a variable in a Common Data Format (CDF) File.
Input Arguments	cdfid Identifier of a CDF file, returned by a call to <code>cdflib.create</code> or <code>cdflib.open</code> .
Output Arguments	ctype Text string identifying the type of compression. For a list of compression types, see <code>cdflib.setCompression</code> . cparams Any additional parameter required by the compression type. percent Numeric value indicating the level of compression, expressed as a percentage.
Examples	Open the example CDF file and check the compression settings of any variable. <pre>cdfid = cdflib.open('example.cdf'); % Check the compression setting of any variable in the file % The example checks the first variable (variable numbers are zero-based) [ctype params percent] = cdflib.getVarCompression(cdfid,0) ctype =</pre>

cdflib.getVarCompression

```
NO_COMPRESSION

params =

    []

percent =

    100

% Clean up
cdflib.close(cdfid);
clear cdfid
```

References

This function corresponds to the CDF library C API routine `CDFgetzVarCompression`.

To use this function, you must be familiar with the CDF C interface. Read the CDF documentation at the [CDF Web site](#).

For copyright information, see the `cdfcopyright.txt` file.

See Also

`cdflib.setCompression` | `cdflib.setVarCompression`

Tutorials

- “Importing CDF Files”
- “Exporting to CDF Files”

Purpose	Single value from record in variable
Syntax	<pre>datum = cdflib.getVarData(cdfId,varNum,recNum,indices) datum = cdflib.getVarData(cdfId,varNum,recNum)</pre>
Description	<p><code>datum = cdflib.getVarData(cdfId,varNum,recNum,indices)</code> returns a single value from a variable in a Common Data Format (CDF) file.</p> <p><code>datum = cdflib.getVarData(cdfId,varNum,recNum)</code> returns a single value from a variable with no dimensions in a Common Data Format (CDF) file.</p>
Input Arguments	<p><code>cdfId</code> Identifier of a CDF file, returned by a call to <code>cdflib.create</code> or <code>cdflib.open</code>.</p> <p><code>varNum</code> Numeric value identifying the variable containing the datum. Variable numbers are zero-based.</p> <p><code>recNum</code> Numeric value identifying the location of the datum in the variable. In CDF terminology, this is called the <i>record number</i>. Record numbers are zero-based.</p> <p><code>indices</code> Array of dimension indices within the record. Dimension indices are zero-based. If the variable has no dimensions, you can omit this parameter.</p>
Output Arguments	<p><code>datum</code> Value of the specified record.</p>

Examples

Open the example CDF file and retrieve data associated with a variable:

```
cdfid = cdflib.open('example.cdf');

% Determine how many variables are in the file.
info = cdflib.inquire(cdfid);

info.numVars

ans =

    5

% Determine if the first variable has dimensions.
varinfo = cdflib.inquireVar(cdfid,0);
vardims = varinfo.dims
vardims =

    []

% Get data from variable, without specifying dimensions.
datum = cdflib.getVarData(cdfid, varnum, recnum)

datum =

    6.3146e+013

% Get dimensions of another variable in file.
varinfo = cdflib.inquireVar(cdfid,3);
vardims = varinfo.dims
vardims =

    [4 2 2]

% Retrieve the first datum in the record. Indices are zero-based.
datum = cdflib.getVarData(cdfid,3,0,[0 0 0])
```

```
info =  
  
    30  
  
% Clean up.  
cdflib.close(cdfid);  
clear cdfid
```

References

This function corresponds to the CDF library C API routine `CDFgetzVarData`.

To use this function, you must be familiar with the CDF C interface. Read the CDF documentation at the [CDF Web site](#).

For copyright information, see the `cdfcopyright.txt` file.

See Also

`cdflib.putVarData` | `cdflib.getVarRecordData` |
`cdflib.hyperGetVarData`

Tutorials

- “Importing CDF Files”
- “Exporting to CDF Files”

cdflib.getVarMaxAllocRecNum

Purpose Maximum allocated record number for variable

Syntax `maxrec = cdflib.getVarMaxAllocRecNum(cdfId,varNum)`

Description `maxrec = cdflib.getVarMaxAllocRecNum(cdfId,varNum)` returns the record number of the maximum allocated record for a variable in a Common Data Format (CDF) file.

`cdfId` identifies the CDF file. `varNum` is a numeric value that identifies the variable. Variable numbers and record numbers are zero-based.

Examples Open example CDF and get the maximum allocated record number for a variable:

```
cdfid = cdflib.open('example.cdf');

% Determine maximum record number for variable in file.
maxRecNum = cdflib.getVarMaxAllocRecNum(cdfid,0)

maxRecNum =

    63

% Clean up
cdflib.close(cdfid)

clear cdfid
```

References This function corresponds to the CDF library C API routine `CDFgetzVarMaxAllocRecNum`.

To use this function, you must be familiar with the CDF C interface. Read the CDF documentation at the [CDF Web site](#).

For copyright information, see the `cdfcopyright.txt` file.

See Also `cdflib.getVarMaxWrittenRecNum`

Tutorials

- “Importing CDF Files”
- “Exporting to CDF Files”

cdflib.getVarMaxWrittenRecNum

Purpose Maximum written record number for variable

Syntax `maxrec = cdflib.getVarMaxwrittenRecNum(cdfId,varNum)`

Description `maxrec = cdflib.getVarMaxwrittenRecNum(cdfId,varNum)` returns the record number of the maximum record written for a variable in a Common Data Format (CDF) file.

`cdfId` identifies the CDF file. `varNum` is a numeric value that identifies the variable. Variable numbers and record numbers are zero-based.

Examples Open the example CDF, and then determine the maximum number of records written to a variable:

```
cdfid = cdflib.open('example.cdf');

% Determine the number records written to variable.
numRecs = cdflib.getVarNumRecsWritten(cdfid,0)

numRecs =

    24

% Determine the maximum record number of the records written
maxRecNum = cdflib.getVarMaxWrittenRecNum(cdfid,0)

maxRecNum =

    23

% Clean up
cdflib.close(cdfid)

clear cdfid
```

References

This function corresponds to the CDF library C API routine `CDFgetzVarMaxWrittenRecNum`.

To use this function, you must be familiar with the CDF C interface. Read the CDF documentation at the [CDF Web site](#).

For copyright information, see the `cdfcopyright.txt` file.

See Also

`cdflib.getVarMaxAllocRecNum` | `cdflib.getVarNumRecsWritten`

Tutorials

- “Importing CDF Files”
- “Exporting to CDF Files”

cdflib.getVarsMaxWrittenRecNum

Purpose Maximum written record number for CDF file

Syntax `maxrec = cdflib.getVarsMaxwrittenRecNum(cdfId)`

Description `maxrec = cdflib.getVarsMaxwrittenRecNum(cdfId)` returns the maximum record number written for all variables in a Common Data Format (CDF) file.

`cdfId` identifies the CDF file. Record numbers are zero-based.

Examples Open the example CDF, and then determine the maximum number of records written to the file:

```
cdfid = cdflib.open('example.cdf');

% Determine the maximum record number of the records written
maxRecNum = cdflib.getVarsMaxWrittenRecNum(cdfid)

maxRecNum =

    23

% Clean up
cdflib.close(cdfid)
```

References This function corresponds to the CDF library C API routine `CDFgetzVarsMaxWrittenRecNum`.

To use this function, you must be familiar with the CDF C interface. Read the CDF documentation at the [CDF Web site](#).

For copyright information, see the `cdfcopyright.txt` file.

See Also `cdflib.getVarMaxWrittenRecNum`

Tutorials

- “Importing CDF Files”
- “Exporting to CDF Files”

Purpose	Variable name, given variable number
Syntax	<code>name = cdflib.getVarName(cdfId,varNum)</code>
Description	<p><code>name = cdflib.getVarName(cdfId,varNum)</code> returns the name of the variable in a Common Data Format (CDF) file.</p> <p><code>cdfId</code> identifies the CDF file. <code>varNum</code> is a numeric value that identifies the variable. Variable numbers are zero-based.<code>name</code> is a text string specifying the name.</p>
Examples	<p>Open the example CDF, and then get the name of a variable in the file:</p> <pre>cdfid = cdflib.open('example.cdf'); name = cdflib.getVarName(cdfid,1) name = Longitude % Clean up cdflib.close(cdfid) clear cdfid</pre>
References	<p>This function corresponds to the CDF library C API routine <code>CDFgetzVarName</code>.</p> <p>To use this function, you must be familiar with the CDF C interface. Read the CDF documentation at the CDF Web site.</p> <p>For copyright information, see the <code>cdfcopyright.txt</code> file.</p>
See Also	<code>cdflib.inquireVar</code>
Tutorials	<ul style="list-style-type: none">• “Importing CDF Files”

cdflib.getVarName

- “Exporting to CDF Files”

Purpose	Variable number, given variable name
Syntax	<code>varNum = cdflib.getVarNum(cdfId, varname)</code>
Description	<code>varNum = cdflib.getVarNum(cdfId, varname)</code> returns the identifier (variable number) for a variable in a Common Data Format (CDF) file. <code>cdfId</code> identifies the CDF file. <code>varname</code> is a text string that identifies the variable. Variable names are case-sensitive.
Examples	<p>Open example CDF, and then get the number of a variable named Longitude:</p> <pre>cdfid = cdflib.open('example.cdf'); varNum = cdflib.getVarNum(cdfid, 'Longitude') varNum = 1 % Clean up cdflib.close(cdfid); clear cdfid</pre>
References	<p>This function corresponds to the CDF library C API routine <code>CDFgetzVarNum</code>.</p> <p>To use this function, you must be familiar with the CDF C interface. Read the CDF documentation at the CDF Web site.</p> <p>For copyright information, see the <code>cdfcopyright.txt</code> file.</p>
See Also	<code>cdflib.getVarName</code>
Tutorials	<ul style="list-style-type: none">• “Importing CDF Files”

cdflib.getVarNum

- “Exporting to CDF Files”

Purpose Number of records written to variable

Syntax `numrecs = cdflib.getVarNumRecsWritten(cdfId,varNum)`

Description `numrecs = cdflib.getVarNumRecsWritten(cdfId,varNum)` returns the total number of records written to a variable in a Common Data Format (CDF) file.

`cdfId` identifies the CDF file. `varNum` is a numeric value that identifies the variable. Variable numbers are zero-based.

Examples Open the example CDF, and then determine the number of records written to a variable:

```
cdfid = cdflib.open('example.cdf');

% Determine the number of records written to the variable.
numRecs = cdflib.getVarNumRecsWritten(cdfid,0)

numRecs =

    24

% Clean up
cdflib.close(cdfid)

clear cdfid
```

References This function corresponds to the CDF library C API routine `CDFgetzVarNumRecsWritten`.

To use this function, you must be familiar with the CDF C interface. Read the CDF documentation at the [CDF Web site](#).

For copyright information, see the `cdfcopyright.txt` file.

See Also `cdflib.getVarMaxWrittenRecNum`

cdflib.getVarNumRecsWritten

Tutorials

- “Importing CDF Files”
- “Exporting to CDF Files”

Purpose	Pad value for variable
Syntax	<code>padvalue = cdflib.getVarPadValue(cdfId,varNum)</code>
Description	<p><code>padvalue = cdflib.getVarPadValue(cdfId,varNum)</code> returns the pad value used with a variable in a Common Data Format (CDF) file.</p> <p><code>cdfId</code> identifies the CDF file. <code>varNum</code> is a numeric value that identifies the variable. Variable numbers are zero-based.</p>
Examples	<p>Open the example CDF, and then determine the pad value for a variable:</p> <pre>cdfid = cdflib.open('example.cdf'); % Check pad value of variable in the file. padval = cdflib.getVarPadValue(cdfid,0) padval = 0 % Clean up. cdflib.close(cdfid); clear cdfid</pre>
References	<p>This function corresponds to the CDF library C API routine <code>CDFgetzVarPadValue</code>.</p> <p>To use this function, you must be familiar with the CDF C interface. Read the CDF documentation at the CDF Web site.</p> <p>For copyright information, see the <code>cdfcopyright.txt</code> file.</p>
See Also	<code>cdflib.setVarPadValue</code>
Tutorials	<ul style="list-style-type: none">• “Importing CDF Files”

cdflib.getVarPadValue

- “Exporting to CDF Files”

Purpose	Entire record for variable
Syntax	<code>data = cdflib.getVarRecordData(cdfId,varNum,recNum)</code>
Description	<code>data = cdflib.getVarRecordData(cdfId,varNum,recNum)</code> returns the data in a record associated with a variable in a Common Data Format (CDF) file.
Input Arguments	<p>cdfId Identifier of a CDF file, returned by a call to <code>cdflib.create</code> or <code>cdflib.open</code>.</p> <p>varNum Numeric value that identifies the variable in the CDF file. Variable numbers are zero-based.</p> <p>recNum Numeric value that identifies the record in the variable. Record numbers are zero-based.</p>
Output Arguments	<p>data Data in the record.</p>
Examples	<p>Open the example CDF, and then get the data associated with a record in a variable:</p> <pre>cdfid = cdflib.open('example.cdf'); % Get data in first record in first variable in file. recData = cdflib.getVarRecordData(cdfid,0,0) recData = 6.3146e+013</pre>

cdflib.getVarRecordData

```
% Clean up
cdflib.close(cdfid)

clear cdfid
```

References

This function corresponds to the CDF library C API routine `CDFgetzVarRecordData`.

To use this function, you must be familiar with the CDF C interface. Read the CDF documentation at the [CDF Web site](#).

For copyright information, see the `cdfcopyright.txt` file.

See Also

`cdflib.putVarRecordData` | `cdflib.getVarData` |
`cdflib.hyperGetVarData`

Tutorials

- “Importing CDF Files”
- “Exporting to CDF Files”

Purpose	Compression reserve percentage for variable
Syntax	<code>percent = cdflib.getVarReservePercent(cdfId,varNum)</code>
Description	<code>percent = cdflib.getVarReservePercent(cdfId,varNum)</code> returns the compression reserve percentage for a variable in a Common Data Format (CDF) file. This operation only applies to compressed variables. <code>cdfId</code> identifies the CDF file. <code>varNum</code> is a numeric value that identifies the variable. Variable numbers are zero-based.
Definitions	reserve percentage Specifies how much extra space to allocate for a compressed variable. This extra space allows the variable to expand when you write additional records to the variable. If you do not specify this room for growth, the library has to move the variable to the end of the file when the size expands and the space at the original location of the variable becomes wasted space. By default, the reserve percent is 0 (no extra space is reserved). You can specify any percentage between 1 and 100 and values greater than 100. The value specifies the percentage of the uncompressed size of the variable.
Examples	Open the example CDF file, get the number of a compressed variable, and then determine the reserve percent for the variable. <pre>cdfid = cdflib.open('example.cdf'); varnum = cdflib.getVarNum(cdfid,'Temperature'); percent = cdflib.getVarReservePercent(cdfid,varnum); cdflib.close(cdfid);</pre>
References	This function corresponds to the CDF library C API routine <code>CDFgetzVarReservePercent</code> . To use this function, you must be familiar with the CDF C interface. Read the CDF documentation at the CDF Web site .

cdflib.getVarReservePercent

For copyright information, see the `cdfcopyright.txt` file.

See Also

`cdflib.setVarReservePercent`

Tutorials

- “Importing CDF Files”
- “Exporting to CDF Files”

Purpose Information about how variable handles sparse records

Syntax `stype = cdflib.getVarSparseRecords(cdfId,varNum)`

Description `stype = cdflib.getVarSparseRecords(cdfId,varNum)` returns information about how a variable in the Common Data Format (CDF) file handles sparse records.

Input Arguments

cdfId

Identifier of a CDF file, returned by a call to `cdflib.create` or `cdflib.open`.

varNum

Numeric value that identifies the variable. Variable numbers are zero-based.

Output Arguments

stype

One of the following text strings, or its numeric equivalent, that specifies how the variable handles sparse records.

Text String	Description
'NO_SPARSERECORDS'	No sparse records.
'PAD_SPARSERECORDS'	For sparse records, the library uses the variable's pad value when reading values from a missing record.
'PREV_SPARSERECORDS'	For sparse records, the library uses values from the previous existing record when reading values from a missing record. If there is no previous existing record, the library uses the variable's pad value.

cdflib.getVarSparseRecords

To get the numeric equivalent of these text strings, use `cdflib.getConstantValue`.

Examples

Open the example CDF, and then get the sparse record type of a variable in the file:

```
cdfid = cdflib.open('example.cdf');  
  
stype = cdflib.getVarSparseRecords(cdfid,0)  
  
stype =  
  
NO_SPARSERECORDS  
  
%Clean up  
cdflib.close(cdfid);  
  
clear cdfid
```

References

This function corresponds to the CDF library C API routine `CDFgetzVarSparseRecords`.

To use this function, you must be familiar with the CDF C interface. Read the CDF documentation at the [CDF Web site](#).

For copyright information, see the `cdfcopyright.txt` file.

See Also

`cdflib.setVarSparseRecords`

Tutorials

- “Importing CDF Files”
- “Exporting to CDF Files”

Purpose Common Data Format (CDF) library version and release information

Syntax [version,release,increment] = cdflib.getVersion(cdfId)

Description [version,release,increment] = cdflib.getVersion(cdfId) returns information about the version of the Common Data Format (CDF) library used to create a CDF file.

Input Arguments **cdfId**
Identifier of a CDF file, returned by a call to `cdflib.create` or `cdflib.open`.

Output Arguments **version**
Numeric value indicating the version number of the CDF library.

release
Numeric value indicating the release number of the CDF library.

increment
Numeric value indicating the increment number of the CDF library.

Examples Open the example CDF file, and then find out the version of the CDF library used to create it:

```
cdfId = cdflib.open('example.cdf');  
  
[version, release, increment] = cdflib.getVersion(cdfId)  
  
version =  
    2  
  
release =
```

cdflib.getVersion

```
7
increment =
8
% Clean up
cdflib.close(cdfId)
clear cdfId
```

References

This function corresponds to the CDF library C API routine `CDF.getVersion`.

To use this function, you must be familiar with the CDF C interface. Read the CDF documentation at the [CDF Web site](#).

For copyright information, see the `cdfcopyright.txt` file.

See Also

`cdflib.getLibraryVersion`

Tutorials

- “Importing CDF Files”
- “Exporting to CDF Files”

Purpose	Read hyperslab of data from variable
Syntax	<pre>data = cdflib.hyperGetVarData(cdfId,varNum,recSpec,dimSpec) data = cdflib.hyperGetVarData(cdfId,varNum,recSpec)</pre>
Description	<p><code>data = cdflib.hyperGetVarData(cdfId,varNum,recSpec,dimSpec)</code> reads a hyperslab of data from a variable in the Common Data Format (CDF) file. Hyper access allows more than one value to be read from or written to a variable with a single call to the CDF library.</p> <p><code>data = cdflib.hyperGetVarData(cdfId,varNum,recSpec)</code> reads a hyperslab of data for a zero-dimensional variable in the Common Data Format (CDF) file.</p>
Input Arguments	<p>cdfId Identifier of a CDF file, returned by a call to <code>cdflib.create</code> or <code>cdflib.open</code>.</p> <p>varNum Number identifying the variable containing the datum.</p> <p>recSpec Three-element array, [RSTART RCOUNT RSTRIDE], where RSTART, RCOUNT, and RSTRIDE are scalar values specifying the starting record, number of records to read, and the sampling interval or stride between records. Record numbers are zero-based.</p> <p>dimSpec Three-element cell array, {DSTART DCOUNT DSTRIDE}, where DSTART, DCOUNT, and DSTRIDE are <i>n</i>-element vectors that describe the start, number of values along each dimension, and sampling interval along each dimension. If the hyperslab has zero dimensions, you can omit this parameter. Dimension indices are zero-based.</p>

cdflib.hyperGetVarData

Examples

Open the example CDF file, and then get all the data associated with a variable:

```
cdfid = cdflib.open('example.cdf');

% Determine the number of records allocated for the first variable in the
maxRecNum = cdflib.getVarMaxWrittenRecNum(cdfid,0);

% Retrieve all data in records for variable.
data = cdflib.hyperGetVarData(cdfid,0,[0 maxRecNum 1]);

% Clean up
cdflib.close(cdfid)

clear cdfid
```

References

This function corresponds to the CDF library C API routine `CDFHyperGetzVarData`.

To use this function, you must be familiar with the CDF C interface. Read the CDF documentation at the [CDF Web site](#).

For copyright information, see the `cdfcopyright.txt` file.

See Also

`cdflib.hyperPutVarData`

Tutorials

- “Importing CDF Files”
- “Exporting to CDF Files”

Purpose	Write hyperslab of data to variable
Syntax	<code>cdflib.hyperPutVarData(cdfId, varNum, recSpec, dimSpec, data)</code>
Description	<code>cdflib.hyperPutVarData(cdfId, varNum, recSpec, dimSpec, data)</code> writes a hyperslab of data to a variable in a Common Data Format (CDF) file. Hyper access allows more than one value to be read from or written to a variable with a single call to the CDF library.
Input Arguments	<p><code>cdfId</code> Identifier of a CDF file, returned by a call to <code>cdflib.create</code> or <code>cdflib.open</code>.</p> <p><code>varNum</code> Specifies the variable containing the datum.</p> <p><code>recSpec</code> Three-element array described by <code>[RSTART RCOUNT RSTRIDE]</code>, where <code>RSTART</code>, <code>RCOUNT</code>, and <code>RSTRIDE</code> are scalar values giving the start, number of records, and sampling interval (or stride) between records. Record indices are zero-based.</p> <p><code>dimSpec</code> Three-element cell array described by <code>{DSTART DCOUNT DSTRIDE}</code>, where <code>DSTART</code>, <code>DCOUNT</code>, and <code>DSTRIDE</code> are n-element vectors that describe the start, number of values along each dimension, and sampling interval along each dimension. If the hyperslab has zero dimensions, you can omit this parameter. Dimension indices are zero-based.</p> <p><code>data</code> Data to write to the variable.</p>
Examples	Create a CDF, create a variable, and then write a slab of data to the variable. To run this example, you must be in a writable folder.

cdflib.hyperPutVarData

```
cdfid = cdflib.create('your_file.cdf');

% Create a variable in the file.
varNum = cdflib.createVar(cdfid, 'Grades', 'cdf_int1', 1, [], true, []);

% Write data to the variable
cdflib.hyperPutVarData(cdfid, varNum, 0, [], int8(98))

%Clean up
cdflib.delete(cdfid);
clear cdfid
```

References

This function corresponds to the CDF library C API routine `CDFhyperzPutVarData`.

To use this function, you must be familiar with the CDF C interface. Read the CDF documentation at the [CDF Web site](#).

For copyright information, see the `cdfcopyright.txt` file.

See Also

`cdflib.hyperGetVarData`

Tutorials

- “Importing CDF Files”
- “Exporting to CDF Files”

Purpose Basic characteristics of Common Data Format (CDF) file

Syntax `info = cdflib.inquire(cdfId)`

Description `info = cdflib.inquire(cdfId)` returns basic information about a Common Data Format (CDF) file.

Input Arguments **cdfId**
Identifier of a CDF file, returned by a call to `cdflib.create` or `cdflib.open`.

Output Arguments **info**
A structure containing the following fields:

Field	Description
encoding	Encoding of the variable data and attribute entry data
majority	Majority of the variable data
maxRec	Maximum record number written to a CDF variable
numVars	Number of CDF variables
numvAttrs	Number of attributes with variable scope
numgAttrs	Number of attributes with global scope

Examples Open the example CDF file, and then get basic information about the file:

```
cdflib = cdflib.open('example.cdf');

info = cdflib.inquire(cdfId)

info =
```

cdflib.inquire

```
encoding: 'IBMPC_ENCODING'  
majority: 'ROW_MAJOR'  
maxRec: 23  
numVars: 5  
numvAttrs: 1  
numgAttrs: 3
```

References

This function corresponds to the CDF library C API routines `CDFinquireCDF` and `CDFgetNumgAttributes`.

To use this function, you must be familiar with the CDF C interface. Read the CDF documentation at the [CDF Web site](#).

For copyright information, see the `cdfcopyright.txt` file.

See Also

`cdflib.inquireVar`

Tutorials

- “Importing CDF Files”
- “Exporting to CDF Files”

Purpose Information about attribute

Syntax `info = cdflib.inquireAttr(cdfId,attrNum)`

Description `info = cdflib.inquireAttr(cdfId,attrNum)` returns information about an attribute in a Common Data Format (CDF) file.

Input Arguments

`cdfId`
Identifier of a CDF file, returned by a call to `cdflib.create` or `cdflib.open`.

`attrNum`
Numeric value that identifies the attribute in the file. Attribute numbers are zero-based.

Output Arguments

`info`
Structure containing the following fields.

Field	Description
<code>name</code>	Attribute's name
<code>scope</code>	Either 'GLOBAL_SCOPE' or 'VARIABLE_SCOPE'
<code>maxgEntry</code>	The maximum entry number used for global attributes.
<code>maxEntry</code>	The maximum entry number used for attributes with variable scope.

Examples Open the example CDF, and then get information about the first attribute in the file.

```
cdfid = cdflib.open('example.cdf');
```

cdflib.inquireAttr

```
% Get information about an attribute
info = cdflib.inquireAttr(cdfid,0)

info =

         name: 'SampleAttribute'
         scope: 'GLOBAL_SCOPE'
    maxgEntry: 4
         maxEntry: -1

% Clean up
cdflib.close(cdfid);

clear cdfid
```

References

This function corresponds to the CDF library C API routine `CDFinquireAttr`.

To use this function, you must be familiar with the CDF C interface. Read the CDF documentation at the [CDF Web site](#).

For copyright information, see the `cdfcopyright.txt` file.

See Also

`cdflib.inquireAttrgEntry` | `cdflib.inquireAttrEntry`

Tutorials

- “Importing CDF Files”
- “Exporting to CDF Files”

Purpose	Information about entry in attribute with variable scope
Syntax	<code>[datatype,numElements] = cdflib.inquireAttrEntry(cdfId,attrNum,entryNum)</code>
Description	<code>[datatype,numElements] = cdflib.inquireAttrEntry(cdfId,attrNum, entryNum)</code> returns the data type and the number of elements for an attribute entry in a Common Data Format (CDF) file.
Input Arguments	<p><code>cdfId</code> Identifier of a CDF file, returned by a call to <code>cdflib.create</code> or <code>cdflib.open</code>.</p> <p><code>attrNum</code> Numeric value identifying an attribute in the file. Attribute numbers are zero-based. The attribute must have variable scope.</p> <p><code>entryNum</code> Numeric value identifying the entry in the attribute. Entry number are zero-based.</p>
Output Arguments	<p><code>datatype</code> Text string identifying a CDF data type. For a list of CDF data types, see <code>cdflib.putAttrEntry</code></p> <p><code>numElements</code> Numeric value indicating the number of elements in the entry.</p>
Examples	<p>Open example CDF, and then get information about entries associated with an attribute in the file:</p> <pre>cdfid = cdflib.open('example.cdf');</pre>

cdflib.inquireAttrEntry

```
% The fourth attribute is of variable scope.
attrscope = cdflib.getAttrScope(cdfid,3)

attrscope =

VARIABLE_SCOPE

% Get information about the first entry for this attribute
[dtype numel] = cdflib.inquireAttrEntry(cdfid,3,0)

dtype =

cdf_char

numel =

    10

% Clean up
cdflib.close(cdfid);

clear cdfid
```

References

This function corresponds to the CDF library C API routine `CDFinquireAttrzEntry`.

To use this function, you must be familiar with the CDF C interface. Read the CDF documentation at the [CDF Web site](#).

For copyright information, see the `cdfcopyright.txt` file.

See Also

`cdflib.inquireAttr` | `cdflib.getAttrScope`

Tutorials

- “Importing CDF Files”
- “Exporting to CDF Files”

Purpose	Information about entry in attribute with global scope
Syntax	<code>[datatype,numElements] = cdflib.inquireAttrgEntry(cdfId,attrNum,entryNum)</code>
Description	<code>[datatype,numElements] = cdflib.inquireAttrgEntry(cdfId,attrNum,entryNum)</code> returns the data type and the number of elements for a global attribute entry in a Common Data Format (CDF) file.
Input Arguments	<p><code>cdfId</code> Identifier of a CDF file, returned by a call to <code>cdflib.create</code> or <code>cdflib.open</code>.</p> <p><code>attrNum</code> Numeric value identifying an attribute in the file. Attribute numbers are zero-based. The attribute must have global scope.</p> <p><code>entryNum</code> Numeric value identifying the entry in the attribute. Entry number are zero-based.</p>
Output Arguments	<p><code>datatype</code> Text string identifying a CDF data type. For a list of CDF data types, see <code>cdflib.putAttrgEntry</code></p> <p><code>numElements</code> Numeric value indicating the number of elements in the entry.</p>
Examples	<p>Open the example CDF, and then get information about entries associated with a global attribute in the file.</p> <pre>cdfid = cdflib.open('example.cdf');</pre>

cdflib.inquireAttrEntry

```
% Any of the first three attributes have global scope.
attrscope = cdflib.getAttrScope(cdfid,0)

attrscope =

GLOBAL_SCOPE

% Get information about the first entry for this attribute
[dtype numel] = cdflib.inquireAttrEntry(cdfid,0,0)

dtype =

cdf_char

numel =

    23

% Clean up
cdflib.close(cdfid);

clear cdfid
```

References

This function corresponds to the CDF library C API routine `CDFinquireAttrEntry`.

To use this function, you must be familiar with the CDF C interface. Read the CDF documentation at the [CDF Web site](#).

For copyright information, see the `cdfcopyright.txt` file.

See Also

`cdflib.inquireAttr` | `cdflib.inquireAttrEntry`

Tutorials

- “Importing CDF Files”
- “Exporting to CDF Files”

Purpose Information about variable

Syntax `info = cdflib.inquireVar(cdfId,varNum)`

Description `info = cdflib.inquireVar(cdfId,varNum)` returns information about a variable in a Common Data Format (CDF) file.

Input Arguments

`cdfId`
Identifier of a CDF file, returned by a call to `cdflib.create` or `cdflib.open`.

`varNum`
Numeric value that identifies the variable. Variable numbers are zero-based.

Output Arguments

`info`
Structure containing the following fields.

Field	Description
<code>name</code>	Name of the variable
<code>datatype</code>	Data type
<code>numElements</code>	Number of elements of the datatype
<code>dims</code>	Sizes of the dimensions
<code>recVariance</code>	Record variance
<code>dimVariance</code>	Dimension variances

Record and dimension variances affect how the library physically stores variable data. For example, if a variable has a record variance of `VARY`, the library physically stores each record. If the record variance is `NOVARY`, the library only stores one record.

cdflib.inquireVar

Examples

Open the example CDF file and get information about a variable.

```
cdfid = cdflib.open('example.cdf');

% Determine if the file contains variables
info = cdflib.inquireVar(cdfid,1)

info =

         name: 'Longitude'
    datatype: 'cdf_int1'
numElements: 1
         dims: [2 2]
recVariance: 0
dimVariance: [1 0]
```

References

This function corresponds to the CDF library C API routine `CDFInquirezVar`.

To use this function, you must be familiar with the CDF C interface. Read the CDF documentation at the [CDF Web site](#).

For copyright information, see the `cdfcopyright.txt` file.

See Also

`cdflib.inquire`

Tutorials

- “Importing CDF Files”
- “Exporting to CDF Files”

Purpose	Open existing Common Data Format (CDF) file
Syntax	<code>cdfId = cdflib.open(filename)</code>
Description	<p><code>cdfId = cdflib.open(filename)</code> opens an existing Common Data Format (CDF) file. <i>filename</i> is a text string that identifies the file.</p> <p>This function returns a CDF file identifier, <code>cdfId</code>.</p> <p>All CDF files opened this way have the <code>zMode</code> set to <code>zModeon2</code>. Refer to the <i>CDF User's Guide</i> for information about <code>zModes</code>.</p>
Examples	<p>Open the example CDF file:</p> <pre>cdfId = cdflib.open('example.cdf'); % Clean up cdflib.close(cdfId) clear cdfId</pre>
References	<p>This function corresponds to the CDF library C API routine <code>CDFopenCDF</code>.</p> <p>To use this function, you must be familiar with the CDF C interface. Read the CDF documentation at the CDF Web site.</p> <p>For copyright information, see the <code>cdfcopyright.txt</code> file.</p>
See Also	<code>cdflib.close</code> <code>cdflib.create</code>
Tutorials	<ul style="list-style-type: none">• “Importing CDF Files”• “Exporting to CDF Files”

cdflib.putAttrEntry

Purpose Write value to entry in attribute with variable scope

Syntax `cdflib.putAttrEntry(cdfId, attrNum, entryNum, CDFDataType, entryVal)`

Description `cdflib.putAttrEntry(cdfId, attrNum, entryNum, CDFDataType, entryVal)` writes a value to an attribute entry in a Common Data Format (CDF) file.

Input Arguments

cdfId

Identifier of a CDF file, returned by a call to `cdflib.create` or `cdflib.open`.

attrNum

Number identifying attribute. The attribute must have variable scope. Attribute numbers are zero-based.

entryNum

Number identifying entry. Entry numbers are zero-based.

CDFdatatype

One of the following text strings, or its numeric equivalent, that specify the data type of the attribute entry.

CDF Data Type	MATLAB Equivalent
CDF_BYTE	1-byte, signed integer
CDF_CHAR	1 byte, signed character data type that maps to the MATLAB <code>char</code> class
CDF_INT1	1-byte, signed integer.
CDF_UCHAR	1 byte, unsigned character data type that maps to the MATLAB <code>uint8</code> class
CDF_UINT1	1-byte, unsigned integer

CDF Data Type	MATLAB Equivalent
CDF_INT2	2-byte, signed integer
CDF_UINT2	2-byte, unsigned integer.
CDF_INT4	4-byte, signed integer
CDF_UINT4	4-byte, unsigned integer
CDF_FLOAT	4-byte, floating point
CDF_REAL4	4-byte, floating point
CDF_REAL8	8-byte, floating point.
CDF_DOUBLE	8-byte, floating point
CDF_EPOCH	8-byte, floating point
CDF_EPOCH16	two 8-byte, floating point

entryVal

Data to be written to attribute entry.

Examples

Create a CDF and create an attribute with variable scope in the file. Write a value to an entry in the attribute. To run this example, you must be in a writable folder.

```
cdfid = cdflib.create('your_file.cdf');

% Initially the file contains no attributes, global or variable.
info = cdflib.inquire(cdfid)

info =

    encoding: 'IBMPC_ENCODING'
    majority: 'ROW_MAJOR'
    maxRec: -1
    numVars: 0
    numvAttrs: 0
```

cdflib.putAttrEntry

```
numgAttrs: 0

% Create an attribute of variable scope in the file.
attrNum = cdflib.createAttr(cdfid,'Another Attribute','variable_scope');

% Write a value to an entry for the attribute
cdflib.putAttrEntry(cdfid,attrNum,0,'CDF_CHAR','My Variable Attribute Test');

% Get the value of the global attribute entry
value = cdflib.getAttrEntry(cdfid,attrNum,0)

value =

My Variable Attribute Test

% Clean up
cdflib.delete(cdfid);

clear cdfid
```

References

This function corresponds to the CDF library C API routine `CDFputAttrEntry`.

To use this function, you must be familiar with the CDF C interface. Read the CDF documentation at the [CDF Web site](#).

For copyright information, see the `cdfcopyright.txt` file.

See Also

`cdflib.getAttrEntry` | `cdflib.putAttrEntry` | `cdflib.getAttrEntry` | `cdflib.getConstantValue`

Tutorials

- “Importing CDF Files”
- “Exporting to CDF Files”

Purpose Write value to entry in attribute with global scope

Syntax `cdflib.putAttrgEntry(cdfId,attrNum,entryNum,cdfDataType,entryVal)`

Description `cdflib.putAttrgEntry(cdfId,attrNum,entryNum,cdfDataType,entryVal)` writes a value to a global attribute entry in a Common Data Format (CDF) file.

Input Arguments

cdfId

Identifier of a CDF file, returned by a call to `cdflib.create` or `cdflib.open`.

attrNum

Number identifying attribute. Attribute numbers are zero-based. The attribute must have global scope.

entryNum

Number identifying entry. Entry numbers are zero-based.

CDFdatatype

One of the following text strings that specify the data type of the attribute entry, or its numeric equivalent.

CDF Data Type	MATLAB Equivalent
CDF_BYTE	1-byte, signed integer
CDF_CHAR	1 byte, signed character data type that maps to the MATLAB <code>char</code> class
CDF_INT1	1-byte, signed integer.
CDF_UCHAR	1 byte, unsigned character data type that maps to the MATLAB <code>uint8</code> class
CDF_UINT1	1-byte, unsigned integer

cdflib.putAttrgEntry

CDF Data Type	MATLAB Equivalent
CDF_INT2	2-byte, signed integer
CDF_UINT2	2-byte, unsigned integer.
CDF_INT4	4-byte, signed integer
CDF_UINT4	4-byte, unsigned integer
CDF_FLOAT	4-byte, floating point
CDF_REAL4	4-byte, floating point
CDF_REAL8	8-byte, floating point.
CDF_DOUBLE	8-byte, floating point
CDF_EPOCH	8-byte, floating point
CDF_EPOCH16	two 8-byte, floating point

entryVal

Data to be written to global attribute entry.

Examples

Create a CDF and create a global attribute in the file. Write a value to an entry in the attribute. To run this example, you must be in a writable folder.

```
cdfid = cdflib.create('your_file.cdf');

% Initially the file contains no attributes, global or variable.
info = cdflib.inquire(cdfid)

info =

    encoding: 'IBMPC_ENCODING'
    majority: 'ROW_MAJOR'
    maxRec: -1
    numVars: 0
    numvAttrs: 0
```



```
numgAttrs: 0

% Create a global attribute in the file.
attrNum = cdflib.createAttr(cdfid, 'Purpose', 'global_scope');

% Write a value to an entry for the global attribute
cdflib.putAttrgEntry(cdfid, attrNum, 0, 'CDF_CHAR', 'My Test');

% Get the value of the global attribute entry
value = cdflib.getAttrgEntry(cdfid, attrNum, 0)

value =

My Test

% Clean up
cdflib.delete(cdfid);

clear cdfid
```

References

This function corresponds to the CDF library C API routine `CDFputAttrgEntry`.

To use this function, you must be familiar with the CDF C interface. Read the CDF documentation at the [CDF Web site](#).

For copyright information, see the `cdfcopyright.txt` file.

See Also

`cdflib.getAttrgEntry` | `cdflib.putAttrEntry` |
`cdflib.getAttrEntry` | `cdflib.getConstantValue`

Tutorials

- “Importing CDF Files”
- “Exporting to CDF Files”

cdflib.putVarData

Purpose Write single value to variable

Syntax `cdflib.putVarData(cdfId,varNum,recNum,indices,datum)`

Description `cdflib.putVarData(cdfId,varNum,recNum,indices,datum)` writes a single value to a variable in a Common Data File (CDF) file.

Input Arguments

cdfId

Identifier of a CDF file, returned by a call to `cdflib.create` or `cdflib.open`.

varNum

Numeric value that identifies the variable to which you want to write the datum. Variable numbers are zero-based.

recNum

Numeric value that identifies the record to which you want to write the datum. Record numbers are zero-based.

dims

Dimension indices within the record. Dimension indices are zero-based.

datum

Data to be written to the variable.

Examples

Create a CDF, create a variable in the CDF and write data to the variable. To run this example, you must have write permission in the current folder.

```
cdfid = cdflib.create('your_file.cdf');  
  
% Create a variable in the file.  
varNum = cdflib.createVar(cdfid,'Grades','cdf_int1',1,[],true,[]);
```

```
% Write some data to the variable
cdflib.putVarData(cdfid,varNum,0,[],int8(98))

% Read the value from the variable.
datum = cdflib.getVarData(cdfid,varNum,0)

datum =

    98

%Clean up
cdflib.delete(cdfid);
clear cdfid
```

References

This function corresponds to the CDF library C API routine `CDFputzVarData`.

To use this function, you must be familiar with the CDF C interface. Read the CDF documentation at the [CDF Web site](#).

For copyright information, see the `cdfcopyright.txt` file.

See Also

`cdflib.getVarData` | `cdflib.getVarRecordData` |
`cdflib.hyperGetVarData`

Tutorials

- “Importing CDF Files”
- “Exporting to CDF Files”

cdflib.putVarRecordData

Purpose	Write entire record to variable
Syntax	<code>cdflib.putVarRecordData(cdfId,varNum,recNum,recordData)</code>
Description	<code>cdflib.putVarRecordData(cdfId,varNum,recNum,recordData)</code> writes data to a record in a variable in a Common Data Format (CDF) file.
Input Arguments	<p><code>cdfId</code> Identifier of a CDF file, returned by a call to <code>cdflib.create</code> or <code>cdflib.open</code>.</p> <p><code>varNum</code> Numeric value that identifies the variable to which you want to write the datum. Variable numbers are zero-based.</p> <p><code>recNum</code> Numeric value identifying the location of the datum in the variable. Record numbers are zero-based.</p> <p><code>recordData</code> Data to be written to the variable.</p>

Examples

Create a CDF, create a variable, and write an entire record of data to the variable. To run this example, you must be in a writable folder.

```
cdfid = cdflib.create('your_file.cdf');  
  
% Create a variable in the file.  
varNum = cdflib.createVar(cdfid,'Grades','cdf_int1',1,[],true,[]);  
  
% Write some data to the variable  
cdflib.putVarRecordData(cdfid,varNum,0,int8(98))
```

```
% Read the value from the variable.
datum = cdflib.getVarData(cdfid,varNum,0)

datum =

    98

%Clean up
cdflib.delete(cdfid);
clear cdfid
```

References

This function corresponds to the CDF library C API routine `CDFputzVarRecordData`.

To use this function, you must be familiar with the CDF C interface. Read the CDF documentation at the [CDF Web site](#).

For copyright information, see the `cdfcopyright.txt` file.

See Also

`cdflib.getVarRecordData` | `cdflib.putVarData` |
`cdflib.hyperPutVarData`

Tutorials

- “Importing CDF Files”
- “Exporting to CDF Files”

cdflib.renameAttr

Purpose Rename existing attribute

Syntax `cdflib.renameAttr(cdfId,attrNum,newName)`

Description `cdflib.renameAttr(cdfId,attrNum,newName)` renames an attribute in a Common Data Format (CDF) file.

`cdfId` identifies the CDF file. `attrNum` is a numeric value that identifies the attribute. Attribute numbers are zero-based. `newName` is a text string that specifies the name you want to assign to the attribute.

Examples Create a CDF, create an attribute in the CDF, and then rename the attribute. To run this example, you must be in a writable folder.

```
cdfid = cdflib.create('your_file.cdf');

% Create an attribute
attrNum = cdflib.createAttr(cdfid,'Purpose','global_scope');

% Rename the attribute
cdflib.renameAttr(cdfid, attrNum, 'NewPurpose');

% Check the name of the attribute
attrName = cdflib.getAttrName(cdfid,anum)

attrName =

NewPurpose

% Clean up
cdflib.delete(cdfid);

clear cdfid
```

References This function corresponds to the CDF library C API routine `CDFrenameAttr`.

To use this function, you must be familiar with the CDF C interface. Read the CDF documentation at the [CDF Web site](#).

For copyright information, see the `cdfcopyright.txt` file.

See Also

`cdflib.createAttr`

Tutorials

- “Importing CDF Files”
- “Exporting to CDF Files”

cdflib.renameVar

Purpose Rename existing variable

Syntax `cdflib.renameVar(cdfId,varNum,newName)`

Description `cdflib.renameVar(cdfId,varNum,newName)` renames a variable in a Common Data Format (CDF) file.

`cdfId` identifies the CDF file. `varNum` is a numeric value that identifies the variable. Variable numbers are zero-based. `newName` is a text string that specifies the name you want to assign to the variable.

Examples Create a CDF, create a variable in the CDF, and then rename the variable. To run this example, you must be in a writable folder.

```
cdfid = cdflib.create('your_file.cdf');

% Create a variable in the file.
varNum = cdflib.createVar(cdfid,'Time','cdf_int1',1,[],true,[]);

% Get the name of the variable.
name = cdflib.getVarName(cdfid,varNum)

name =

Time

% Rename the variable
cdflib.renameVar(cdfid,varNum,'NewName');

% Check the new name.
name = cdflib.getVarName(cdfid,varNum)

name =

NewName

% Clean up
```



```
cdflib.delete(cdfid)
```

```
clear cdfid
```

References

This function corresponds to the CDF library C API routine `CDFrenamezVar`.

To use this function, you must be familiar with the CDF C interface. Read the CDF documentation at the [CDF Web site](#).

For copyright information, see the `cdfcopyright.txt` file.

See Also

```
cdflib.createVar
```

Tutorials

- “Importing CDF Files”
- “Exporting to CDF Files”

cdflib.setCacheSize

Purpose Specify number of dotCDF cache buffers

Syntax `cdflib.setCacheSize(cdfId,numBuffers)`

Description `cdflib.setCacheSize(cdfId,numBuffers)` specifies the number of cache buffers the CDF library uses for an open dotCDF file. A *dotCDF* file is a file with the `.cdf` file extension.

`cdfId` identifies an open CDF file. `numBuffers` is a numeric value that specifies the number of buffers.

For information about cache schemes, see the *CDF User's Guide*.

Examples Create a CDF file and set the cache size. To run this example, you must have write permission in your current folder.

```
cdfId = cdflib.create('your_file.cdf');
```

```
% Get the default cache size  
numBuf = cdflib.getCacheSize(cdfid)
```

```
numBuf =
```

```
    300
```

```
% Specify a cache size  
cdflib.setCacheSize(cdfid,150)
```

```
% Check the cache size again  
numBuf = cdflib.getCacheSize(cdfid)
```

```
numBuf =
```

```
    150
```

```
% Clean up  
cdflib.delete(cdfId)  
clear cdfId
```

References

This function corresponds to the CDF library C API routine `CDFsetCacheSize`.

To use this function, you must be familiar with the CDF C interface. Read the CDF documentation at the [CDF Web site](#).

For copyright information, see the `cdfcopyright.txt` file.

See Also

`cdflib.getCacheSize`

Tutorials

- “Importing CDF Files”
- “Exporting to CDF Files”

cdflib.setChecksum

Purpose Specify checksum mode

Syntax `cdflib.setChecksum(cdfId,mode)`

Description `cdflib.setChecksum(cdfId,mode)` specifies the checksum mode of a Common Data Format (CDF) file.

Input Arguments

`cdfId`
Identifier of a CDF file, returned by a call to `cdflib.create` or `cdflib.open`.

`mode`

Either of the following text strings, or its numeric equivalent. To get the numeric equivalent of these values, use `cdflib.getConstantValue`.

'MD5_CHECKSUM'	Sets file checksum to MD5 checksum.
'NO_CHECKSUM'	File does not use a checksum.

Examples Create a CDF file and set the checksum mode. To run this example, you must be in a writable folder.

```
cdfid = cdflib.create('mycdf.cdf');

% Check initial value of checksum.
mode = cdflib.getChecksum(cdfid)

NO_CHECKSUM

cdflib.setChecksum(cdfid,'MD5_CHECKSUM')

% Verify the setting
mode = cdflib.getChecksum(cdfid)

MD5_CHECKSUM
```

References

This function corresponds to the CDF library C API routine `CDFsetChecksum`.

To use this function, you must be familiar with the CDF C interface. Read the CDF documentation at the [CDF Web site](#).

For copyright information, see the `cdfcopyright.txt` file.

See Also

`cdflib.getChecksum` | `cdflib.getConstantValue`

Tutorials

- “Importing CDF Files”
- “Exporting to CDF Files”

cdflib.setCompression

Purpose Specify compression settings

Syntax `cdflib.setCompression(cdfId, ctype, cparms)`

Description `cdflib.setCompression(cdfId, ctype, cparms)` specifies compression settings of a Common Data Format (CDF) file.

This function sets the compression for the CDF file itself, not that of any variables in the file.

Input Arguments

cdfId

Identifier of a CDF file, returned by a call to `cdflib.create` or `cdflib.open`.

ctype

One of the following text strings, or its numeric equivalent, specifying compression type.

Text String	Compression Type
'NO_COMPRESSION'	No compression
'RLE_COMPRESSION'	Run-length encoding compression
'HUFF_COMPRESSION'	Huffman compression
'AHUFF_COMPRESSION'	Adaptive Huffman compression
'GZIP_COMPRESSION'	GNU's zip compression

To get the numeric equivalent, use `cdflib.getConstantValue`.

cparms

Optional parameter specifying any additional parameters required by the compression type. Currently, the only compression type that uses this parameter is 'GZIP_COMPRESSION'. For this compression type, use `cparms` to specify the level of compression as a numeric value between 1 and 9.

Examples

Create a CDF file and set the compression setting of the file. To run this example, your current folder must be writable.

```
cdfId = cdflib.create('your_file.cdf');

% Determine the file's default compression setting
[ctype, cparms, cpercent] = cdflib.getCompression(cdfId)

ctype =

NO_COMPRESSION

cparms =

[]

cpercent =

100

% Specify new compression setting
cdflib.setCompression(cdfId,'HUFF_COMPRESSION');

% Check the file's compression setting.
[ctype, cparms, cpercent] = cdflib.getCompression(cdfId)

ctype =

HUFF_COMPRESSION

cparms =

OPTIMAL_ENCODING_TREES

cpercent =
```

cdflib.setCompression

0

```
% Clean up  
cdflib.delete(cdfId)  
clear cdfId
```

References

This function corresponds to the CDF library C API routine `CDFsetCompression`.

To use this function, you must be familiar with the CDF C interface. Read the CDF documentation at the [CDF Web site](#).

For copyright information, see the `cdfcopyright.txt` file.

See Also

`cdflib.getCompression` | `cdflib.getConstantValue`

Tutorials

- “Importing CDF Files”
- “Exporting to CDF Files”

Purpose

Specify number of compression cache buffers

Syntax

```
cdflib.setCompressionCacheSize(cdfId,numBuffers)
```

Description

`cdflib.setCompressionCacheSize(cdfId,numBuffers)` specifies the number of cache buffers used for the compression scratch CDF file. For more information about CDF cache schemes, see the *CDF User's Guide*.

`cdfId` identifies the CDF file. `numBuffers` specifies the number of buffers.

Examples

Create a CDF file and specify the number of compression cache buffers used. To run this example you must be in a writable folder.

```
cdfId = cdflib.create('your_file.cdf');

% Get the current number of compression cache buffers
numBuf = cdflib.getCompressionCacheSize(cdfId)

numBuf =

    80

% Set a new value
cdflib.setCompressionCacheSize(cdfId,100)

% Check the new value
numBuf = cdflib.getCompressionCacheSize(cdfId)

numBuf =

    100

% Clean up
cdflib.delete(cdfId)
clear cdfId
```

cdflib.setCompressionCacheSize

References

This function corresponds to the CDF library C API routine `CDFsetCompressionCacheSize`.

To use this function, you must be familiar with the CDF C interface. Read the CDF documentation at the [CDF Web site](#).

For copyright information, see the `cdfcopyright.txt` file.

See Also

`cdflib.getCompressionCacheSize`

Tutorials

- “Importing CDF Files”
- “Exporting to CDF Files”

Purpose Set backward compatibility mode

Syntax `cdflib.getFileBackward(mode)`

Description `cdflib.getFileBackward(mode)` sets the backward compatibility mode to the value specified by `mode`.

Tips

- Setting backward compatibility mode affects only your current MATLAB session, or until you call `cdflib.setFileBackward` again.

Input Arguments **mode**
One of the following text strings:

BACKWARDFILEon	Set backward compatibility mode on.
BACKWARDFILEoff	Set backward compatibility mode off.

Default: BACKWARDFILEoff

Definitions **backward compatibility mode**

When specified, ensures that any new CDF file created using CDF V3.0 (or later) will be readable by clients using version 2.7 of the CDF library. CDF 3.0 and later releases use a 64-bit file offset to allow for files greater than 2G bytes in size. CDF library versions released before CDF 3.0 use a 32-bit file offset.

Examples Set backward compatibility mode and then check the value.

```
cdflib.setFileBackward('BACKWARDFILEon');
```

```
mode = cdflib.getFileBackward
```

```
mode =
```

```
BACKWARDFILEon
```

cdflib.setFileBackward

References

This function corresponds to the CDF library C API routine `CDFsetFileBackward`.

To use this function, you must be familiar with the CDF C interface. Read the CDF documentation at the [CDF Web site](#).

For copyright information, see the `cdfcopyright.txt` file.

See Also

`cdflib.getFileBackward` | `cdflib.getConstantValue`

Tutorials

- “Importing CDF Files”
- “Exporting to CDF Files”

Purpose Specify format of Common Data Format (CDF) file

Syntax `cdflib.setFormat(cdfId, format)`

Description `cdflib.setFormat(cdfId, format)` specifies the format of a Common Data Format (CDF) file.

Input Arguments

cdfId

Identifier of a CDF file, returned by a call to `cdflib.create` or `cdflib.open`.

format

Either of the following text strings, or its numeric equivalent.

'SINGLE_FILE'	The CDF consists of only one file. This is the default file format
'MULTI_FILE'	The CDF consists of one header file for control and attribute data and one additional file for each variable in the CDF.

To get the numeric equivalent of these values, use `cdflib.getConstantValue`.

Examples

Create a CDF file and specify its format. To run this example, you must have write permission in your current folder.

```
cdfId = cdflib.create('mycdffile.cdf');

% Specify multifile format.
cdflib.setFormat(cdfId, 'MULTI_FILE');

% Check format.
format = cdflib.getFormat(cdfId)

format =
```

cdflib.setFormat

MULTI_FILE

```
% Clean up
cdflib.delete(cdfId)
clear cdfId
```

References

This function corresponds to the CDF library C API routine `CDFsetFormat`.

To use this function, you must be familiar with the CDF C interface. Read the CDF documentation at the [CDF Web site](#).

For copyright information, see the `cdfcopyright.txt` file.

See Also

`cdflib.getFormat` | `cdflib.getConstantValue`

Tutorials

- “Importing CDF Files”
- “Exporting to CDF Files”

Purpose Specify majority of variables

Syntax `cdflib.setMajority(cdfId,majority)`

Description `cdflib.setMajority(cdfId,majority)` specifies the majority of variables in a Common Data Format (CDF) file.

Input Arguments

`cdfId`
Identifier of a CDF file, returned by a call to `cdflib.create` or `cdflib.open`.

`majority`

Either of the following text strings, or its numeric equivalent.

'ROW_MAJOR'	C-like array ordering for variable storage. The first dimension in each variable array varies the slowest. This is the default.
'COLUMN_MAJOR'	Fortran-like array ordering for variable storage. The first dimension in each variable array varies the fastest.

To get the numeric equivalent of these values, use `cdflib.getConstantValue`.

Examples

Create a CDF file and specify the majority used by variables in the file. To run this example, you must have write permission in your current folder.

```
cdfId = cdflib.create('your_file.cdf')

% Specify the majority used by variables in the file
cdflib.setMajority(cdfId,'COLUMN_MAJOR');

% Check the majority value
majority = cdflib.getMajority(cdfId)
```

cdflib.setMajority

```
majority =  
  
COLUMN_MAJOR  
  
% Clean up  
cdflib.delete(cdfId)  
clear cdfId
```

References

This function corresponds to the CDF library C API routine `CDFsetMajority`.

To use this function, you must be familiar with the CDF C interface. Read the CDF documentation at the [CDF Web site](#).

For copyright information, see the `cdfcopyright.txt` file.

See Also

`cdflib.getMajority`

Tutorials

- “Importing CDF Files”
- “Exporting to CDF Files”

Purpose

Specify read-only mode

Syntax

```
cdflib.setReadOnlyMode(cdfId,mode)
```

Description

`cdflib.setReadOnlyMode(cdfId,mode)` specifies the read-only mode of a Common Data Format (CDF) file.

After you open a CDF file, you can put the file into read-only mode to prevent accidental modification.

Input Arguments

cdfId

Identifier of a CDF file, returned by a call to `cdflib.create` or `cdflib.open`.

mode

Either of the following text strings or its numeric equivalent.

'READONLYon'	CDF file is read-only
'READONLYoff'	CDF file is modifiable.

To get the numeric equivalent of these mode values, use `cdflib.getConstantValue`.

Examples

Open the example CDF file and set the file to read-only mode.

```
cdfId = cdflib.open('example.cdf');

% Set the file to READONLY mode
cdflib.setReadOnlyMode(cdfId,'READONLYon')

% Check read-only status of file again.
mode = cdflib.getReadOnlyMode(cdfId)

mode =

READONLYon
```

cdflib.setReadOnlyMode

```
% Clean up
cdflib.close(cdfId)
clear cdfId
```

References

This function corresponds to the CDF library C API routine `CDFsetReadOnlyMode`.

To use this function, you must be familiar with the CDF C interface. Read the CDF documentation at the [CDF Web site](#).

For copyright information, see the `cdfcopyright.txt` file.

See Also

`cdflib.getReadOnlyMode` | `cdflib.getConstantValue`

Tutorials

- “Importing CDF Files”
- “Exporting to CDF Files”

Purpose Specify number of staging cache buffers for Common Data Format (CDF) file

Syntax `cdflib.setStageCacheSize(cdfId,numBuffers)`

Description `cdflib.setStageCacheSize(cdfId,numBuffers)` specifies the number of staging cache buffers for a Common Data Format (CDF) file. For information about CDF cache schemes, see the *CDF User's Guide*.

`cdfId` identifies the CDF file. `numBuffers` is a numeric value that specifies the number of buffers.

Examples Open the example CDF file and specify the number of cache buffers used.

```
cdfId = cdflib.open('example.cdf');

% Get current number of staging cache buffers
size = cdflib.getStageCacheSize(cdfId)

size =

    125

% Specify new cache size value.
cdflib.setStageCacheSize(cdfId, 200)

% Get size again.
size = cdflib.getStageCacheSize(cdfId)

size =

    200

% Clean up
cdflib.close(cdfId)
```

cdflib.setStageCacheSize

`clear cdfId`

References

This function corresponds to the CDF library C API routine `CDFsetStageCacheSize`.

To use this function, you must be familiar with the CDF C interface. Read the CDF documentation at the [CDF Web site](#).

For copyright information, see the `cdfcopyright.txt` file.

See Also

`cdflib.getStageCacheSize`

Tutorials

- “Importing CDF Files”
- “Exporting to CDF Files”

Purpose Specify library validation mode

Syntax `cdflib.setValidate(mode)`

Description `cdflib.setValidate(mode)` specifies the validation mode of the Common Data Format (CDF) library. Specify the validation mode before opening any files.

Input Arguments

mode

Either of the following text strings, or its numeric equivalent:

'VALIDATEFILEon'	Turns validation mode on. With validation mode on, the library performs sanity checks on the data fields in the CDF file's internal data structures to make sure that the values are within valid ranges and consistent with the defined values/types/entries. This mode also ensures that variable and attribute associations within the file are valid. Note, however, that enabling this mode will, in most cases, slow down the file opening process, especially for large or very fragmented files.
'VALIDATEFILEoff'	Turns validation mode off.

To get the numeric equivalent of these values, use `cdflib.getConstantValue`.

Examples Set the validation mode of the CDF library.

```
cdflib.setValidate('VALIDATEFILEon');
```

References This function corresponds to the CDF library C API routine `CDFsetValidate`.

To use this function, you must be familiar with the CDF C interface. Read the CDF documentation at the [CDF Web site](#).

For copyright information, see the `cdfcopyright.txt` file.

cdflib.setValidate

See Also

`cdflib.getValidate` | `cdflib.getConstantValue`

Tutorials

- “Importing CDF Files”
- “Exporting to CDF Files”

Purpose	Specify range of records to be allocated for variable
Syntax	<code>cdflib.setVarAllocBlockRecords(cdfId,varNum,firstrec,lastrec)</code>
Description	<code>cdflib.setVarAllocBlockRecords(cdfId,varNum,firstrec,lastrec)</code> specifies a range of records you want to allocate (but not write) for a variable in a Common Data Format (CDF) file.
Input Arguments	<p><code>cdfId</code> Identifier of a CDF file, returned by a call to <code>cdflib.create</code> or <code>cdflib.open</code>.</p> <p><code>varNum</code> Numeric value identifying a variable in the file. Variable identifiers (variable numbers) are zero-based.</p> <p><code>firstRec</code> Numeric value identifying the record at which to start allocating. Record numbers are zero-based.</p> <p><code>lastRec</code> Numeric value identifying the record at which to stop allocating. Record numbers are zero-based.</p>
Examples	<p>Create a CDF, create a variable in the CDF, and then specify the number of records to allocate for the variable. To run this example, you must be in a writable folder.</p> <pre>cdfid = cdflib.create('your_file.cdf'); % Create a variable in the file. varNum = cdflib.createVar(cdfid,'Grades','cdf_int1',1,[],true,[]); % Specify the number of records to allocate.</pre>

cdflib.setVarAllocBlockRecords

```
cdflib.setVarAllocBlockRecords(cdfid,varNum,1,10);
```

```
% Clean up  
cdflib.delete(cdfid)
```

```
clear cdfid
```

References

This function corresponds to the CDF library C API routine `CDFsetzVarAllocBlockRecords`.

To use this function, you must be familiar with the CDF C interface. Read the CDF documentation at the [CDF Web site](#).

For copyright information, see the `cdfcopyright.txt` file.

See Also

`cdflib.getVarAllocRecords`

Tutorials

- “Importing CDF Files”
- “Exporting to CDF Files”

Purpose	Specify blocking factor for variable
Syntax	<code>cdflib.setVarBlockingFactor(cdfId,varNum,blockingFactor)</code>
Description	<code>cdflib.setVarBlockingFactor(cdfId,varNum,blockingFactor)</code> specifies the blocking factor for a variable in a Common Data Format (CDF) file.
Input Arguments	<p>cdfId Identifier of a CDF file, returned by a call to <code>cdflib.create</code> or <code>cdflib.open</code>.</p> <p>varNum Numeric value identifying a variable in the file. Variable numbers are zero-based.</p> <p>blockingFactor Numeric value that specifies the number of records to allocate when writing to an unallocated record.</p>
Definitions	<p>blocking factor</p> <p>A variable's <i>blocking factor</i> specifies the minimum number of records the library allocates when you write to an unallocated record. If you specify a fractional blocking factor, the library rounds the value down.</p>
Examples	<p>Create a CDF, create a variable in the CDF, and then set the blocking factor used with the variable. To run this example, you must be in a writable folder.</p> <pre>cdfid = cdflib.create('your_file.cdf'); % Create a variable in the file. varNum = cdflib.createVar(cdfid,'Time','cdf_int1',1,[],true,[]);</pre>

cdflib.setVarBlockingFactor

```
% Get the current blocking factor used with the variable
bFactor = cdflib.getVarBlockingFactor(cdfid,varNum)

bFactor =

    0

% Change the blocking factor for the variable
cdflib.setVarBlockingFactor(cdfid,varNum,10);

% Check the new blocking factor .
bFactor = cdflib.getVarBlockingFactor(cdfid,varNum)

bFactor =

    10

% Clean up
cdflib.delete(cdfid)

clear cdfid
```

References

This function corresponds to the CDF library C API routine `CDFsetzVarBlockingFactor`.

To use this function, you must be familiar with the CDF C interface. Read the CDF documentation at the [CDF Web site](#).

For copyright information, see the `cdfcopyright.txt` file.

See Also

`cdflib.getVarBlockingFactor`

Tutorials

- “Importing CDF Files”
- “Exporting to CDF Files”

Purpose

Specify number of multi-file cache buffers for variable

Syntax

```
cdflib.setVarCacheSize(cdfId,varNum,numBuffers)
```

Description

`cdflib.setVarCacheSize(cdfId,varNum,numBuffers)` specifies the number of cache buffers the CDF library uses for a variable in a Common Data Format (CDF) file.

This function is only used with multifile format CDF files. It does not apply to single-file format CDFs. For more information about caching, see the *CDF User's Guide*.

Input Arguments

cdfId

Identifier of a CDF file, returned by a call to `cdflib.create` or `cdflib.open`.

varNum

Numeric value identifying a variable in the file. Variable identifiers (variable numbers) are zero-based.

numBuffers

Numeric value identifying the number of cache buffers to use.

Examples

Create a multifile CDF, and then retrieve the number of buffers being used for a variable:

```
cdfid = cdflib.create('your_file.cdf')

% Set the format of the file to be multi-file
cdflib.setFormat(cdfid,'MULTI_FILE');

% Create a variable in the file
varNum = cdflib.createVar(cdfid,'Time','cdf_int1',1,[],true,[]);

% Note how the library creates a separate file for the variable
```

cdflib.setVarCacheSize

```
ls your_file.*

your_file.cdf  your_file.z0

% Determine the number of cache buffers used with the variable
numBuf = cdflib.getVarCacheSize(cdfid,varNum)

numBuf =

    1

% Increase the number of cache buffers used.
cdflib.setVarCacheSize(cdfid,varNum,5)

% Check the number of cache buffers used with the variable.
numBuf = cdflib.getVarCacheSize(cdfid,varNum)

numBuf =

    5

% Clean up
cdflib.delete(cdfid);

clear cdfid
```

References

This function corresponds to the CDF library C API routine `CDFsetzVarCacheSize`.

To use this function, you must be familiar with the CDF C interface. Read the CDF documentation at the [CDF Web site](#).

For copyright information, see the `cdfcopyright.txt` file.

See Also

`cdflib.getVarCacheSize` | `cdflib.setVarsCacheSize`

Tutorials

- “Importing CDF Files”

- “Exporting to CDF Files”

cdflib.setVarCompression

Purpose Specify compression settings used with variable

Syntax `cdflib.setVarCompression(cdfId, varNum, ctype, cparams)`

Description `cdflib.setVarCompression(cdfId, varNum, ctype, cparams)` configures the compression setting for a variable in a Common Data Format (CDF) file.

Input Arguments

cdfId

Identifier of a CDF file, returned by a call to `cdflib.create` or `cdflib.open`.

varNum

Numeric value identifying a variable in the file. Variable identifiers (variable numbers) are zero-based.

ctype

One of the following text strings, or its numeric equivalent, specifying the compression type.

Text String	Compression Type
'NO_COMPRESSION'	No compression.
'RLE_COMPRESSION'	Run-length encoding compression
'HUFF_COMPRESSION'	Huffman compression
'AHUFF_COMPRESSION'	Adaptive Huffman compression
'GZIP_COMPRESSION'	GNU's zip compression

cparams

Optional parameter specifying any additional parameters required by the compression type. Currently, the only compression type that uses this parameter is 'GZIP_COMPRESSION'. For this compression type,

you use `cparms` to specify the level of compression as a numeric value between 1 and 9.

Examples

Create a CDF, create a variable, and then set the compression used by the variable. To run this example, you must be in a folder with execute permission.

```
cdfid = cdflib.create('mycdf.cdf');

% Create a variable in the file.
varNum = cdflib.createVar(cdfid,'Time','cdf_int1',1,[],true,[]);

% Specify the compression used by the variable.
cdflib.setVarCompression(cdfid,0,'GZIP_COMPRESSION',8)

% Check the compression setting of the variable
[ctype params percent] = cdflib.getVarCompression(cdfid,0)

ctype =

GZIP_COMPRESSION

params =

      8

percent =

      0

% Clean up
cdflib.delete(cdfid);
clear cdfid
```

References

This function corresponds to the CDF library C API routine `CDFsetzVarCompression`.

cdflib.setVarCompression

To use this function, you must be familiar with the CDF C interface. Read the CDF documentation at the [CDF Web site](#).

For copyright information, see the `cdfcopyright.txt` file.

See Also

`cdflib.setCompression` | `cdflib.getVarCompression`

Tutorials

- “Importing CDF Files”
- “Exporting to CDF Files”

Purpose

Specify initial number of records written to variable

Syntax

```
cdflib.setVarInitialRecs(cdfId,varNum,numrecs)
```

Description

`cdflib.setVarInitialRecs(cdfId,varNum,numrecs)` specifies the initial number of records to write to a variable in a Common Data Format (CDF) file.

Input Arguments**`cdfId`**

Identifier of a CDF file, returned by a call to `cdflib.create` or `cdflib.open`.

`varNum`

Numeric value identifying a variable in the file. Variable numbers are zero-based.

`numRecs`

Numeric value specifying the number of records to write.

Examples

Create a CDF, create a variable, and then specify the number of records to write for the variable. To run this example, you must be in a writable folder.

```
cdfid = cdflib.create('your_file.cdf');

% Create a variable in the file.
varNum = cdflib.createVar(cdfid,'Grades','cdf_int1',1,[],true,[]);

% Specify the number of records to write for the variable
cdflib.setVarInitialRecs(cdfid,varNum,100);

recsWritten = cdflib.getVarNumRecsWritten(cdfid,varNum)

recsWritten =
```

cdflib.setVarInitialRecs

100

```
% Clean up  
cdflib.delete(cdfid)
```

```
clear cdfid
```

References

This function corresponds to the CDF library C API routine `CDFsetzVarInitialRecs`.

To use this function, you must be familiar with the CDF C interface. Read the CDF documentation at the [CDF Web site](#).

For copyright information, see the `cdfcopyright.txt` file.

See Also

`cdflib.createVar`

Tutorials

- “Importing CDF Files”
- “Exporting to CDF Files”

Purpose	Specify pad value used with variable
Syntax	<code>cdflib.setVarPadValue(cdfId,varNum,padvalue)</code>
Description	<code>cdflib.setVarPadValue(cdfId,varNum,padvalue)</code> specifies the pad value used with a variable in a Common Data Format (CDF) file.
Input Arguments	<p>cdfId Identifier of a CDF file, returned by a call to <code>cdflib.create</code> or <code>cdflib.open</code>.</p> <p>varNum Numeric value identifying a variable in the file. Variable numbers are zero-based.</p> <p>padValue Value to use a pad value for the variable. The data type of the pad value must match the data type of the variable.</p>
Examples	<p>Create a CDF, create a variable in the CDF, and then set the pad value used with the variable. To run this example, you must be in a writable folder.</p> <pre>cdfid = cdflib.create('your_file.cdf'); % Create a variable in the file. varNum = cdflib.createVar(cdfid,'Time','cdf_int1',1,[],true,[]); % Get the current pad value used with the variable padval = cdflib.getVarPadValue(cdfid,varNum) padval = 0</pre>

cdflib.setVarPadValue

```
% Change the pad value for the variable
cdflib.setVarPadValue(cdfid,varNum,int8(1));

% Check the new pad value.
padval = cdflib.getVarPadValue(cdfid,varNum)

padval =

     1

% Clean up
cdflib.delete(cdfid)

clear cdfid
```

References

This function corresponds to the CDF library C API routine `CDFsetzVarPadValue`.

To use this function, you must be familiar with the CDF C interface. Read the CDF documentation at the [CDF Web site](#).

For copyright information, see the `cdfcopyright.txt` file.

See Also

`cdflib.getVarPadValue`

Tutorials

- “Importing CDF Files”
- “Exporting to CDF Files”

Purpose	Specify reserve percentage for variable
Syntax	<code>cdflib.setVarReservePercent(cdfId,varNum,percent)</code>
Description	<code>cdflib.setVarReservePercent(cdfId,varNum,percent)</code> specifies the compression reserve percentage for a variable in a Common Data Format (CDF) file.
Input Arguments	<p>cdfId Identifier of a CDF file, returned by a call to <code>cdflib.create</code> or <code>cdflib.open</code>.</p> <p>varNum Numeric value identifying a variable in the file. Variable identifiers (variable numbers) are zero-based.</p> <p>percent Numeric value specifying the amount of extra space to allocate for a compressed variable, expressed as a percentage. You can specify values between 0 (no extra space is reserved) and 100, or values greater than 100. The value specifies the percentage of the uncompressed size of the variable. If you specify a fractional reserve percentages, the library rounds the value down.</p>
Definitions	<p>reserve percentage Specifies how much extra space to allocate for a compressed variable. This extra space allows the variable to expand when you write additional records to the variable. If you do not specify this room for growth, the library has to move the variable to the end of the file when the size expands and the space at the original location of the variable becomes wasted space.</p>

cdflib.SetVarReservePercent

Examples

Create a CDF, create a variable, set the compression of the variable, and then set the reserve percent for the variable. To run this example, you must be in a writable folder.

```
cdfid = cdflib.create('your_file.cdf');

% Create a variable in the file.
varNum = cdflib.createVar(cdfid, 'Time', 'cdf_int1', 1, [], true, []);

% Set the compression of the variable.
cdflib.setVarCompression(cdfid, varNum, 'GZIP_COMPRESSION', 8);

% Set the compression reserver percentage
cdflib.setVarReservePercent(cdfid, varNum, 80);

cdflib.close(cdfid);
```

References

This function corresponds to the CDF library C API routine `CDFsetzVarReservePercent`.

To use this function, you must be familiar with the CDF C interface. Read the CDF documentation at the [CDF Web site](#).

For copyright information, see the `cdfcopyright.txt` file.

See Also

`cdflib.getVarReservePercent` | `cdflib.setVarCompression` | `cdflib.getVarCompression`

Tutorials

- “Importing CDF Files”
- “Exporting to CDF Files”

Purpose	Specify number of cache buffers used for all variables
Syntax	<code>cdflib.setVarsCacheSize(cdfId,varNum,numBuffers)</code>
Description	<p><code>cdflib.setVarsCacheSize(cdfId,varNum,numBuffers)</code> specifies the number of cache buffers the CDF library uses for all the variables in the multifile format Common Data Format (CDF) file.</p> <p>This function is not applicable to single-file CDFs. For more information about caching, see the <i>CDF User's Guide</i>.</p>
Input Arguments	<p>cdfId Identifier of a CDF file, returned by a call to <code>cdflib.create</code> or <code>cdflib.open</code>.</p> <p>varNum Numeric value identifying a variable in the file. Variable identifiers (variable numbers) are zero-based.</p> <p>numBuffers Numeric value specifying the cache buffers.</p>
Examples	<p>Create a multifile CDF and specify the number of buffers used for all variables. To run this example, you must be in a writable folder.</p> <pre>cdfid = cdflib.create('your_file.cdf') % Set the format of the file to be multi-file cdflib.setFormat(cdfid,'MULTI_FILE'); % Create a variable in the file varNum = cdflib.createVar(cdfid,'Time','cdf_int1',1,[],true,[]); % Note how the library creates a separate file for the variable ls your_file.*</pre>

cdflib.setVarsCacheSize

```
your_file.cdf  your_file.z0

% Determine the number of cache buffers used with the variable
numBuf = cdflib.getVarCacheSize(cdfid,varNum)

numBuf =

    1

% Specify the number of cache buffers used by all variables in CDF.
cdflib.setVarsCacheSize(cdfid,6)

% Check the number of cache buffers used with the variable.
numBuf = cdflib.getVarCacheSize(cdfid,varNum)

numBuf =

    6

% Clean up
cdflib.delete(cdfid);

clear cdfid
```

References

This function corresponds to the CDF library C API routine `CDFsetzVarsCacheSize`.

To use this function, you must be familiar with the CDF C interface. Read the CDF documentation at the [CDF Web site](#).

For copyright information, see the `cdfcopyright.txt` file.

See Also

`cdflib.getVarCacheSize` | `cdflib.setVarCacheSize`

Tutorials

- “Importing CDF Files”
- “Exporting to CDF Files”

Purpose

Specify how variable handles sparse records

Syntax

```
cdflib.getVarSparseRecords(cdfId, varNum, stype)
```

Description

`cdflib.getVarSparseRecords(cdfId, varNum, stype)` specifies the sparse records type of a variable in a Common Data Format (CDF) file.

Input Arguments

cdfId

Identifier of a CDF file, returned by a call to `cdflib.create` or `cdflib.open`.

varNum

Number that identifies the variable to be set. Variable numbers are zero-based.

stype

One of the following text strings, or its numeric equivalent, that specifies how the variable handles sparse records.

Text String	Description
'NO_SPARSERECORDS'	No sparse records
'PAD_SPARSERECORDS'	For sparse records, the library uses the variable's pad value when reading values from a missing record.
'PREV_SPARSERECORDS'	For sparse records, the library uses values from the previous existing record when reading values from a missing record. If there is no previous existing record, the library uses the variable's pad value.

To get the numeric equivalent of these text string constants, use the `cdflib.getConstantValue` function.

cdflib.setVarSparseRecords

Examples

Open a multifile CDF and close a variable.

Create a CDF, create a variable, and set the sparse records type of the variable. To run this example you must be in a writable folder.

```
cdfid = cdflib.create('your_file.cdf');

% Create a variable in the file.
varNum = cdflib.createVar(cdfid,'Time','cdf_int1',1,[],true,[]);

% Set the sparse records type of the variable
cdflib.setVarSparseRecords(cdfid,varNum,'PAD_SPARSERECORDS');

% Check the sparse records type of the variable
stype = cdflib.getVarSparseRecords(cdfid,varNum)

stype =

PAD_SPARSERECORDS

%Clean up
cdflib.delete(cdfid);

clear cdfid
```

References

This function corresponds to the CDF library C API routine `CDFsetzVarSparseRecords`.

To use this function, you must be familiar with the CDF C interface. Read the CDF documentation at the [CDF Web site](#).

For copyright information, see the `cdfcopyright.txt` file.

See Also

`cdflib.getVarSparseRecords` | `cdflib.getConstantValue`

Tutorials

- “Importing CDF Files”
- “Exporting to CDF Files”

Purpose

Read data from Common Data Format (CDF) file

Syntax

```
data = cdfread(filename)
data = cdfread(filename, param1, val1, param2, val2, ...)
[data, info] = cdfread(filename, ...)
```

Description

`data = cdfread(filename)` reads all the data from the Common Data Format (CDF) file specified in the string `filename`. CDF data sets typically contain a set of variables, of a specific data type, each with an associated set of records. The variable might represent time values with each record representing a specific time that an observation was recorded. `cdfread` returns all the data in a cell array where each column represents a variable and each row represents a record associated with a variable. If the variables have varying numbers of associated records, `cdfread` pads the rows to create a rectangular cell array, using pad values defined in the CDF file.

Note Because `cdfread` creates temporary files, the current working directory must be writeable.

`data = cdfread(filename, param1, val1, param2, val2, ...)` reads data from the file, where `param1`, `param2`, and so on, can be any of the parameters listed in the following table.

`[data, info] = cdfread(filename, ...)` returns details about the CDF file in the `info` structure.

Parameter	Value
'Records'	A vector specifying which records to read. Record numbers are zero-based. <code>cdfread</code> returns a cell array with the same number of rows as the number of records read and as many columns as there are variables.
'Variables'	A 1-by- n or n -by-1 cell array specifying the names of the variables to read from the file. n must be less than or equal to the total number of variables in the file. <code>cdfread</code> returns a cell array with the same number of columns as the number of variables read, and a row for each record read.
'Slices'	An m -by-3 array, where each row specifies where to start reading along a particular dimension of a variable, the skip interval to use on that dimension (every item, every other item, etc.), and the total number of values to read on that dimension. m must be less than or equal to the number of dimensions of the variable. If m is less than the total number of dimensions, <code>cdfread</code> reads every value from the unspecified dimensions ($[0 \ 1 \ n]$, where n is the total number of elements in the dimension. Note: Because the 'Slices' parameter describes how to process a single variable, it must be used in conjunction with the 'Variables' parameter.
'ConvertEpochToDatenum'	A Boolean value that determines whether <code>cdfread</code> automatically converts CDF epoch data types to MATLAB serial date numbers. If set to <code>false</code> (the default), <code>cdfread</code> wraps epoch values in MATLAB <code>cdfepoch</code> objects. Note: For better performance when reading large data sets, set this parameter to <code>true</code> .
'CombineRecords'	A Boolean value that determines how <code>cdfread</code> returns the CDF data sets read from the file. If set to <code>false</code> (the default), <code>cdfread</code> stores the data in an m -by- n cell array, where m is the number of records and n is the number

Parameter	Value
	<p>of variables requested. If set to <code>true</code>, <code>cdfread</code> combines all records for a particular variable into one cell in the output cell array. In this cell, <code>cdfread</code> stores scalar data as a column array. <code>cdfread</code> extends the dimensionality of nonscalar and string data. For example, instead of creating 1000 elements containing 20-by-30 arrays for each record, <code>cdfread</code> stores all the records in one cell as a 1000-by-20-by-30 array</p> <p>Note: If you use the 'Records' parameter to specify which records to read, you cannot use the 'CombineRecords' parameter.</p> <p>Note: When using the 'Variable' parameter to read one variable, if the 'CombineRecords' parameter is <code>true</code>, <code>cdfread</code> returns the data as an M-by-N numeric or character array; it does not put the data into a cell array.</p>

Note To improve performance when working with large data files, use the 'ConvertEpochToDatetime' and 'CombineRecords' options.

Note To improve performance, turn off the file validation which the CDF library does by default when opening files. For more information, see `cdflib.setValidate`.

Examples

Read all the data from a CDF file.

```
data = cdfread('example.cdf');
```

Read the data from the variable 'Time'.

```
data = cdfread('example.cdf', 'Variable', {'Time'});
```

Read the first value in the first dimension, the second value in the second dimension, the first and third values in the third dimension, and all values in the remaining dimension of the variable 'multidimensional'.

```
data = cdfread('example.cdf', ...  
             'Variable', {'multidimensional'}, ...  
             'Slices', [0 1 1; 1 1 1; 0 2 2]);
```

This is similar to reading the whole variable into data and then using matrix indexing, as in the following.

```
data{1}(1, 2, [1 3], :)
```

Collapse the records from a data set and convert CDF epoch data types to MATLAB serial date numbers.

```
data = cdfread('example.cdf', ...  
             'CombineRecords', true, ...  
             'ConvertEpochToDatenum', true);
```

See Also

[cdfepoch](#) | [cdfinfo](#) | [cdflib.setValidate](#)

How To

- “Importing CDF Files”

Purpose

Write data to Common Data Format (CDF) file

Note `cdfwrite` is not recommended. Use the `cdflib` low-level functions instead.

Syntax

```
cdfwrite(filename,variablelist)
cdfwrite(...,'PadValues',padvals)
cdfwrite(...,'GlobalAttributes',gattrib)
cdfwrite(...,'VariableAttributes',vattrib)
cdfwrite(...,'WriteMode',mode)
cdfwrite(...,'Format',format)
```

Description

`cdfwrite(filename,variablelist)` writes out a Common Data Format (CDF) file, specified in `filename`. The `filename` input is a string enclosed in single quotes. The `variablelist` argument is a cell array of ordered pairs, each of which comprises a CDF variable name (a string) and the corresponding CDF variable value. To write out multiple records for a variable, put the values in a cell array where each element in the cell array represents a record.

Note Because `cdfwrite` creates temporary files, both the destination directory for the file and the current working directory must be writeable.

`cdfwrite(...,'PadValues',padvals)` writes out pad values for given variable names. `padvals` is a cell array of ordered pairs, each of which comprises a variable name (a string) and a corresponding pad value. Pad values are the default values associated with the variable when an out-of-bounds record is accessed. Variable names that appear in `padvals` must appear in `variablelist`.

`cdfwrite(...,'GlobalAttributes',gattrib)` writes the structure `gattrib` as global metadata for the CDF file. Each field of the structure

is the name of a global attribute. The value of each field contains the value of the attribute. To write out multiple values for an attribute, put the values in a cell array where each element in the cell array represents a record.

Note To specify a global attribute name that is invalid in your MATLAB application, create a field called 'CDFAttributeRename' in the attribute structure. The value of this field must have a value that is a cell array of ordered pairs. The ordered pair consists of the name of the original attribute, as listed in the `GlobalAttributes` structure, and the corresponding name of the attribute to be written to the CDF file.

`cdfwrite(..., 'VariableAttributes', vattrib)` writes the structure `vattrib` as variable metadata for the CDF. Each field of the struct is the name of a variable attribute. The value of each field should be an M-by-2 cell array where M is the number of variables with attributes. The first element in the cell array should be the name of the variable and the second element should be the value of the attribute for that variable.

Note To specify a variable attribute name that is illegal in MATLAB, create a field called 'CDFAttributeRename' in the attribute structure. The value of this field must have a value that is a cell array of ordered pairs. The ordered pair consists of the name of the original attribute, as listed in the `VariableAttributes` struct, and the corresponding name of the attribute to be written to the CDF file. If you are specifying a variable attribute of a CDF variable that you are renaming, the name of the variable in the `VariableAttributes` structure must be the same as the renamed variable.

`cdfwrite(..., 'WriteMode', mode)`, where *mode* is either 'overwrite' or 'append', indicates whether or not the specified variables should be

appended to the CDF file if the file already exists. By default, `cdfwrite` overwrites existing variables and attributes.

`cdfwrite(..., 'Format', format)`, where *format* is either 'multifile' or 'singlefile', indicates whether or not the data is written out as a multifile CDF. In a multifile CDF, each variable is stored in a separate file with the name *.vN, where N is the number of the variable that is written out to the CDF. By default, `cdfwrite` writes out a single file CDF. When 'WriteMode' is set to 'Append', the 'Format' option is ignored, and the format of the preexisting CDF is used.

Examples

Write out a file 'example.cdf' containing a variable 'Longitude' with the value [0:360].

```
cdfwrite('example', {'Longitude', 0:360});
```

Write out a file 'example.cdf' containing variables 'Longitude' and 'Latitude' with the variable 'Latitude' having a pad value of 10 for all out-of-bounds records that are accessed.

```
cdfwrite('example', {'Longitude', 0:360, 'Latitude', 10:20}, ...  
        'PadValues', {'Latitude', 10});
```

Write out a file 'example.cdf', containing a variable 'Longitude' with the value [0:360], and with a variable attribute of 'validmin' with the value 10.

```
varAttribStruct.validmin = {'Longitude' [10]};  
cdfwrite('example', {'Longitude' 0:360}, 'VariableAttributes', ...  
        varAttribStruct);
```

See Also

`cdfread` | `cdfinfo` | `cdfepoch`

ceil

Purpose Round toward positive infinity

Syntax `B = ceil(A)`

Description `B = ceil(A)` rounds the elements of `A` to the nearest integers greater than or equal to `A`. For complex `A`, the imaginary and real parts are rounded independently.

Examples `a = [-1.9, -0.2, 3.4, 5.6, 7, 2.4+3.6i]`

```
a =  
Columns 1 through 4  
-1.9000    -0.2000    3.4000    5.6000  
  
Columns 5 through 6  
7.0000    2.4000 + 3.6000i
```

```
ceil(a)
```

```
ans =  
Columns 1 through 4  
-1.0000    0    4.0000    6.0000  
  
Columns 5 through 6  
7.0000    3.0000 + 4.0000i
```

See Also `fix` | `floor` | `round`

Purpose	Create cell array
Syntax	<pre>C = cell(dim) C = cell(dim1,...,dimN) D = cell(obj)</pre>
Description	<p><code>C = cell(dim)</code> creates a cell array of empty matrices. If <code>dim</code> is a scalar, <code>C</code> is <code>dim</code>-by-<code>dim</code>. If <code>dim</code> is a vector, <code>C</code> is <code>dim(1)</code>-by-...-<code>dim(N)</code>, where <code>N</code> is the number of elements of <code>dim</code>.</p> <p><code>C = cell(dim1,...,dimN)</code> creates cell array <code>C</code>, where <code>C</code> is <code>dim1</code>-by-...-<code>dimN</code>.</p> <p><code>D = cell(obj)</code> converts a Java array or .NET array of <code>System.String</code> or <code>System.Object</code> into a MATLAB cell array.</p>
Tips	<p>Creating an empty array with the <code>cell</code> function, such as</p> <pre>C = cell(3,4,2);</pre> <p>is exactly equivalent to assigning an empty array to the last index of a new cell array:</p> <pre>C{3,4,2} = [];</pre>
Input Arguments	<p>dim</p> <p>Scalar integer or vector of integers that specifies the dimensions of cell array <code>C</code>.</p> <p>dim1,...,dimN</p> <p>Scalar integers that specify the dimensions of <code>C</code>.</p> <p>obj</p> <p>One of the following:</p> <ul style="list-style-type: none">• Java array or object• .NET array of type <code>System.String</code> or <code>System.Object</code>

Output Arguments

C

Cell array. Each cell contains an empty, 0-by-0 array of type double.

D

Cell array. Each cell contains a MATLAB type closest to the Java or .NET type. For more information, see:

- “Conversion of Java Return Types”
- “.NET Type to MATLAB Type Mapping”

Examples

Create an empty 3-by-4-by-2 cell array.

```
mycell = cell(3,4,2);
```

Create a cell array that is the same size as `mycell`, created in the previous example.

```
similar = cell(size(mycell));
```

Convert an array of `java.lang.String` objects into a MATLAB cell array.

```
strArray = java_array('java.lang.String', 3);  
strArray(1) = java.lang.String('one');  
strArray(2) = java.lang.String('two');  
strArray(3) = java.lang.String('three');
```

```
cellArray = cell(strArray)
```

This code returns

```
cellArray =  
    'one'  
    'two'
```

'three'

Create a cell array of folders in the c:\work folder, using the .NET Framework System.IO.Directory class :

```
myList = cell(System.IO.Directory.GetDirectories('c:\work'));  
celldisp(myList)
```

See Also

num2cell | table | ones | rand | randn | zeros

How To

- “Access Data in a Cell Array”

cell2mat

Purpose Convert cell array to numeric array

Syntax `A= cell2mat(C)`

Description `A= cell2mat(C)` converts cell array `C` with contents of the same data type into a single array, `A`.

Input Arguments

C

Cell array, where each cell contains the same type of data. The `cell2mat` function accepts numeric or character data within cells of `C`, but not structs, objects, or nested cells.

The contents of `C` must support concatenation into a hyperrectangle. Otherwise, the results are undefined. For example, the contents of cells in the same column must have the same number of columns, although they need not have the same number of rows.

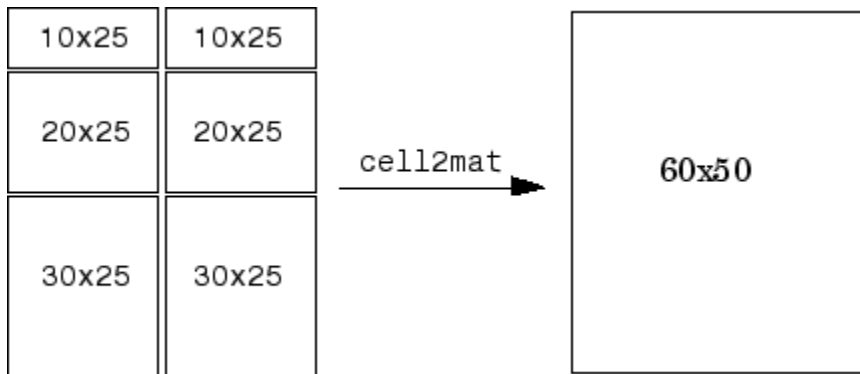

Output Arguments

A

Array of the same type as the contents of the cells of `C`. The number of dimensions of `A` matches the highest number of dimensions of arrays within `C`.

Examples

Combine matrices in the four cells of cell array `c` into matrix `m`.

```
c = {[1], [2, 3, 4];  
     [5; 9], [6, 7, 8; 10, 11, 12]};
```

```
m = cell2mat(c)
```

`m` is a 3-by-4 matrix:

```
m =  
     1     2     3     4  
     5     6     7     8  
     9    10    11    12
```

See Also

[mat2cell](#) | [num2cell](#)

cell2struct

Purpose Convert cell array to structure array

Syntax `structArray = cell2struct(cellArray, fields, dim)`

Description `structArray = cell2struct(cellArray, fields, dim)` creates a structure array, `structArray`, from the information contained within cell array `cellArray`.

The `fields` argument specifies field names for the structure array. This argument is an array of strings or a cell array of strings.

The `dim` argument tells MATLAB which axis of the cell array to use in creating the structure array. Use a numeric double to specify `dim`.

To create a structure array with fields derived from `N` rows of a cell array, specify `N` field names in the `fields` argument, and the number 1 in the `dim` argument. To create a structure array with fields derived from `M` columns of a cell array, specify `M` field names in the `fields` argument and the number 2 in the `dim` argument.

The `structArray` output is a structure array with `N` fields, where `N` is equal to the number of fields in the `fields` input argument. The number of fields in the resulting structure must equal the number of cells along dimension `dim` that you want to convert.

Examples

Create the following table for use with the examples in this section. The table lists information about the employees of a small Engineering company. Reading the table by rows shows the names of employees by department. Reading the table by columns shows the number of years each employee has worked at the company.

	5 Years	10 Years	15 Years
Development	Lee, Reed, Hill	Dean, Frye	Lane, Fox, King
Sales	Howe, Burns	Kirby, Ford	Hall
Management	Price	Clark, Shea	Sims

	5 Years	10 Years	15 Years
Quality	Bates, Gray	Nash	Kay, Chase
Documentation	Lloyd, Young	Ryan, Hart, Roy	Marsh

Enter the following commands to create the initial cell array employees:

```
devel = {'Lee','Reed','Hill'}, {'Dean','Frye'}, ...  
        {'Lane','Fox','King'};   
sales = {'Howe','Burns'}, {'Kirby','Ford'}, {'Hall'};   
mgmt = {'Price'}, {'Clark','Shea'}, {'Sims'};   
qual = {'Bates','Gray'}, {'Nash'}, {'Kay','Chase'};   
docu = {'Lloyd','Young'}, {'Ryan','Hart','Roy'}, {'Marsh'};
```

```
employees = [devel; sales; mgmt; qual; docu]   
employees =
```

```
    {1x3 cell}    {1x2 cell}    {1x3 cell}   
    {1x2 cell}    {1x2 cell}    {1x1 cell}   
    {1x1 cell}    {1x2 cell}    {1x1 cell}   
    {1x2 cell}    {1x1 cell}    {1x2 cell}   
    {1x2 cell}    {1x3 cell}    {1x1 cell}
```

This is the resulting cell array:

cell2struct

	fiveYears	tenYears	fifteenYears
development	Lee Reed Hill	Dean Frye	Lane Fox King
sales	Howe Burns	Kirby Ford	Hall
management	Price	Clark Shea	Sims
quality	Bates Gray	Nash	Kay Chase
documentation	Young Lloyd	Ryan Hart Roy	Marsh

5 x 3 cell array

Convert the cell array to a struct along dimension 1:

- 1 Convert the 5-by-3 cell array along its first dimension to construct a 3-by-1 struct array with 5 fields. Each of the rows along dimension 1 of the cell array becomes a field in the struct array:

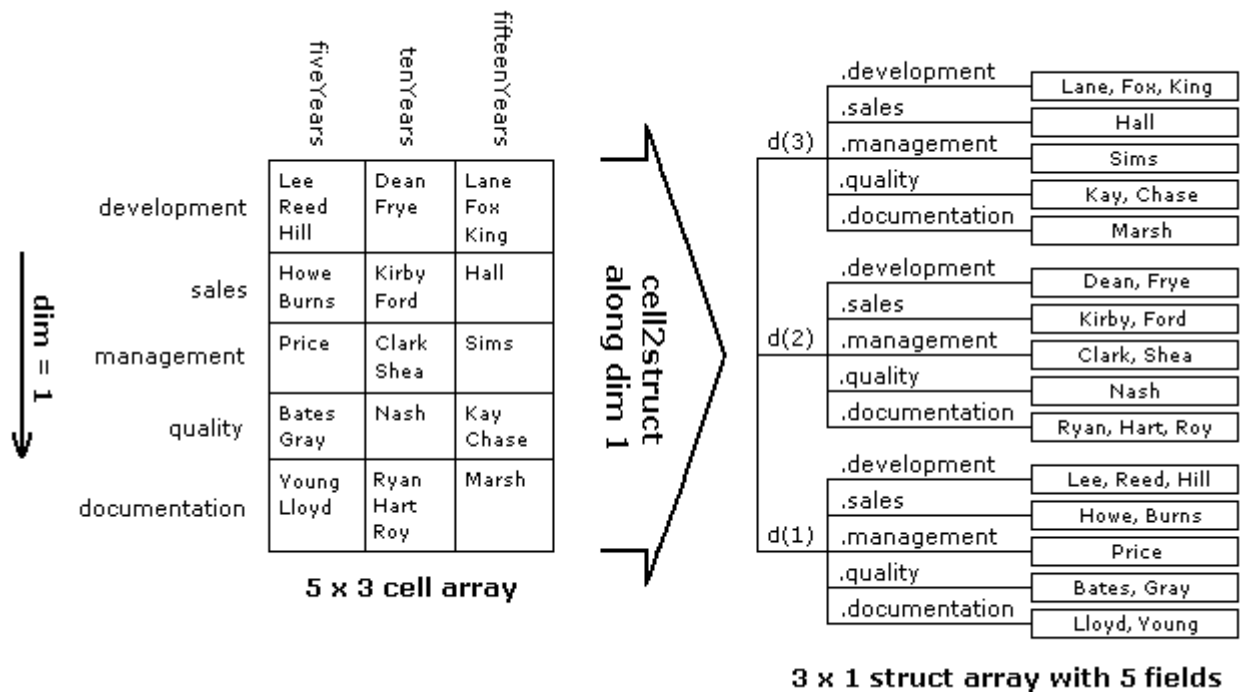

Traversing the first (i.e., vertical) dimension, there are 5 rows with row headings that read as follows:

```
rowHeadings = {'development', 'sales', 'management', ...
               'quality', 'documentation'};
```

- Convert the cell array to a struct array, `depts`, in reference to this dimension:

```
depts = cell2struct(employees, rowHeadings, 1)
depts =
3x1 struct array with fields:
    development
    sales
```

```
management
quality
documentation
```

- 3** Use this row-oriented structure to find the names of the Development staff who have been with the company for up to 10 years:

```
depts(1:2).development
ans =
    'Lee'    'Reed'    'Hill'
ans =
    'Dean'   'Frye'
```

Convert the same cell array to a struct along dimension 2:

- 1** Convert the 5-by-3 cell array along its second dimension to construct a 5-by-1 struct array with 3 fields. Each of the columns along dimension 2 of the cell array becomes a field in the struct array:

	fiveYears	tenYears	fifteenYears	
development	Lee Reed Hill	Dean Frye	Lane Fox King	5 x 3 cell array
sales	Howe Burns	Kirby Ford	Hall	
management	Price	Clark Shea	Sims	
quality	Bates Gray	Nash	Kay Chase	
documentation	Young Lloyd	Ryan Hart Roy	Marsh	

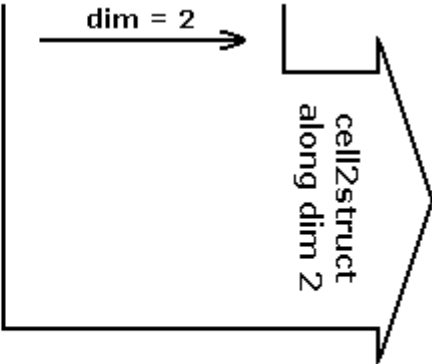

5 x 1 struct array with 3 fields

y(5)	.fiveYears	Lloyd, Young
	.tenYears	Ryan, Hart, Roy
	.fifteenYears	Marsh
y(4)	.fiveYears	Bates, Gray
	.tenYears	Nash
y(3)	.fifteenYears	Kay, Chase
	.fiveYears	Lauer
	.tenYears	Clark, Shea
y(2)	.fifteenYears	Sims
	.fiveYears	Howe, Burns
y(1)	.tenYears	Kirby, Ford
	.fifteenYears	Hall
	.fiveYears	Lee, Reed, Hill
	.tenYears	Dean, Frye
	.fifteenYears	Lane, Fox, King

- 2** Traverse the cell array along the second (or horizontal) dimension. The column headings become fields of the resulting structure:

```
colHeadings = {'fiveYears' 'tenYears' 'fifteenYears'};

years = cell2struct(employees, colHeadings, 2)
years =
5x1 struct array with fields:
    fiveYears
    tenYears
    fifteenYears
```

- 3** Using the column-oriented structure, show how many employees from the Sales and Documentation departments have worked for the company for at least 5 years:

```
[~, sales_5years, ~, ~, docu_5years] = years.fiveYears
sales_5years =
    'Howe'    'Burns'
docu_5years =
    'Lloyd'   'Young'
```

Convert only part of the cell array to a struct:

- 1** Convert only the first and last rows of the cell array. This results in a 3-by-1 struct array with 2 fields:

```
rowHeadings = {'development', 'documentation'};

depts = cell2struct(employees([1,5],:), rowHeadings, 1)
depts =
3x1 struct array with fields:
    development
    documentation
```

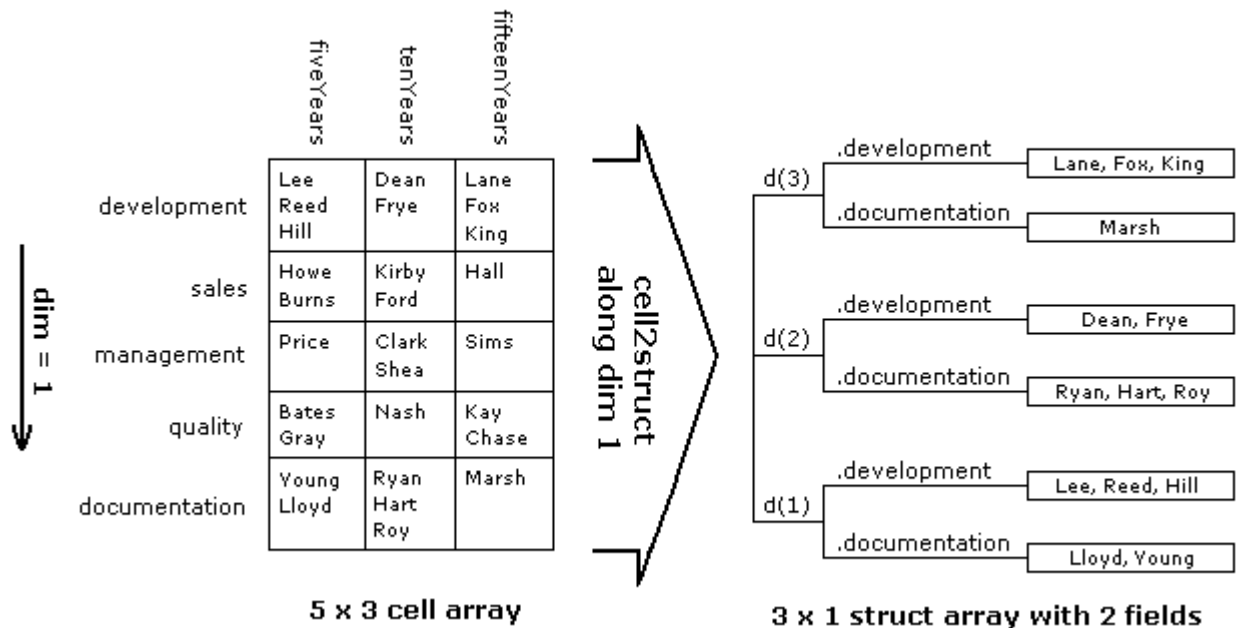

- 2 Display those employees who belong to these departments for all three periods of time:

```

for k=1:3
    depts(k,:)
end

ans =
    development: {'Lee' 'Reed' 'Hill'}
    documentation: {'Lloyd' 'Young'}
ans =
    development: {'Dean' 'Frye'}
    documentation: {'Ryan' 'Hart' 'Roy'}
ans =
    development: {'Lane' 'Fox' 'King'}
  
```

cell2struct

documentation: {'Marsh'}

See Also

[struct2cell](#) | [cell2table](#) | [table2struct](#) | [cell](#) | [iscell](#) | [struct](#)
| [isstruct](#) | [fieldnames](#)

How To

- [dynamic field names](#)

Purpose	Convert cell array to table
Syntax	<pre>T = cell2table(C) T = cell2table(C,Name,Value)</pre>
Description	<p><code>T = cell2table(C)</code> converts the contents of an <i>m</i>-by-<i>n</i> cell array, <i>C</i>, to an <i>m</i>-by-<i>n</i> table, <i>T</i>. Each variable in the table, <i>T</i>, is numeric, with a data type <code>double</code>, or a cell array of strings.</p> <p><code>cell2table</code> uses the input array name appended with the column number for the variable names in the table. If these names are not valid MATLAB identifiers, <code>cell2table</code> uses strings of the form <code>'Var1'</code>, ..., <code>'VarN'</code> where <i>N</i> is the number of columns in <i>C</i>.</p> <p><code>T = cell2table(C,Name,Value)</code> creates a table from a cell array, <i>C</i>, with additional options specified by one or more <i>Name,Value</i> pair arguments.</p> <p>For example, you can specify row names or variable names to include in the table.</p>
Input Arguments	<p>C - Input cell array 2-D cell array</p> <p>Input cell array, specified as a 2-D cell array.</p> <p>If the cell contents have compatible sizes and types, then <code>cell2table</code> vertically concatenates the contents of the cells in each column of <i>C</i> to create each variable in <i>T</i>. If the cell contents have different sizes or incompatible types, then the corresponding variable in the table, <i>T</i>, is a column of cells.</p> <p>Name-Value Pair Arguments</p> <p>Specify optional comma-separated pairs of <i>Name,Value</i> arguments. <i>Name</i> is the argument name and <i>Value</i> is the corresponding value. <i>Name</i> must appear inside single quotes (<code>' '</code>). You can specify several name and value pair arguments in any order as <code>Name1,Value1,...,NameN,ValueN</code>.</p>

Example: `RowNames', {'row1', 'row2', 'row3'}` uses the row names, `row1`, `row2`, and `row3` for the table, `T`.

'RowNames' - Row names for T

`{}` (default) | cell array of nonempty, distinct strings

Row names for `T`, specified as the comma-separated pair consisting of `'RowNames'` and a cell array of nonempty, distinct strings. The number of strings must equal the number of rows, `size(C,1)`.

'VariableNames' - Variable names for T

cell array of nonempty, distinct strings

Variable names for `T`, specified as the comma-separated pair consisting of `'VariableNames'` and a cell array of nonempty, distinct strings. The number of strings must equal the number of variables, `size(C,2)`.

Furthermore, the strings must be valid MATLAB identifiers. If valid MATLAB identifiers are not available for use as variable names, MATLAB uses a cell array of `N` strings of the form `{'Var1' ... 'VarN'}`, where `N` is the number of variables. You can determine valid MATLAB variable names using the function `isvarname`.

Output Arguments

T - Output table

table

Output table, returned as a table. The table can store metadata such as descriptions, variable units, variable names, and row names. For more information, see [Table Properties](#).

Examples

Convert Cell Array to Table

Create a cell array containing strings and numeric data.

```
C = {5 'cereal' 110 'C+'; 12 'pizza' 140 'B'; ...  
    23 'salmon' 367 'A'; 2 'cookies' 160 'D'}
```

```
C =
```

```
[ 5]    'cereal'    [110]    'C+'
[12]    'pizza'    [140]    'B'
[23]    'salmon'   [367]    'A'
[ 2]    'cookies'  [160]    'D'
```

Convert the cell array, `C`, to a table and specify variable names.

```
T = cell2table(C,...
    'VariableNames',{'Age' 'FavoriteFood' 'Calories' 'NutritionGrade'})
```

T =

Age	FavoriteFood	Calories	NutritionGrade
5	'cereal'	110	'C+'
12	'pizza'	140	'B'
23	'salmon'	367	'A'
2	'cookies'	160	'D'

The variables `T.Age` and `T.Calories` are numeric while the variables `T.FavoriteFood` and `T.NutritionGrade` are cell arrays of strings.

Convert Column Headings to Variable Names

Convert a cell array to a table, and then include the first row from the cell array as variable names for the table.

Create a cell array where the first row contains strings to identify column headings.

```
Patients = {'Gender' 'Age' 'Height' 'Weight' 'Smoker';...
    'M' 38 71 176 true;...
    'M' 43 69 163 false;...
    'M' 38 64 131 false;...
    'F' 38 64 131 false;...
    'F' 40 67 133 false;...
    'F' 49 64 119 false}
```

cell2table

```
Patients =
```

```
    'Gender'    'Age'    'Height'    'Weight'    'Smoker'
    'M'         [ 38]    [  71]    [  176]    [    1]
    'M'         [ 43]    [  69]    [  163]    [    0]
    'M'         [ 38]    [  64]    [  131]    [    0]
    'F'         [ 38]    [  64]    [  131]    [    0]
    'F'         [ 40]    [  67]    [  133]    [    0]
    'F'         [ 49]    [  64]    [  119]    [    0]
```

Exclude the columns headings and convert the contents of the cell array to a table.

```
C = Patients(2:end,:);
T = cell2table(C)
```

```
T =
```

C1	C2	C3	C4	C5
'M'	38	71	176	true
'M'	43	69	163	false
'M'	38	64	131	false
'F'	38	64	131	false
'F'	40	67	133	false
'F'	49	64	119	false

The table, T, has variable names C1, ..., C5.

Change the variable names by setting the table property, T.Properties.VariableNames, to the first row of the cell array.

```
T.Properties.VariableNames = Patients(1,:)
```

```
T =
```

Gender	Age	Height	Weight	Smoker
--------	-----	--------	--------	--------

'M'	38	71	176	true
'M'	43	69	163	false
'M'	38	64	131	false
'F'	38	64	131	false
'F'	40	67	133	false
'F'	49	64	119	false

See Also

[table2cell](#) | [array2table](#) | [struct2table](#) | [table](#) | [isvarname](#)

Related Examples

- “Access Data in a Table”

celldisp

Purpose Display cell array contents

Syntax `celldisp(C)`
`celldisp(C, name)`

Description `celldisp(C)` recursively displays the contents of a cell array. `celldisp(C, name)` uses the string *name* for the display instead of the name of the first input (or ans).

Examples Use `celldisp` to display the contents of a 2-by-3 cell array:

```
C = {[1 2] 'Tony' 3+4i; [1 2;3 4] -5 'abc'};  
celldisp(C)
```

```
C{1,1} =  
    1    2
```

```
C{2,1} =  
    1    2  
    3    4
```

```
C{1,2} =  
Tony
```

```
C{2,2} =  
-5
```

```
C{1,3} =  
3.0000+ 4.0000i
```

```
C{2,3} =  
abc
```

See Also `cellplot`

How To

- “Export Cell Array to Text File”

Purpose

Apply function to each cell in cell array

Syntax

```
[A1,...,Am] = cellfun(func,C1,...,Cn)
[A1,...,Am] = cellfun(func,C1,...,Cn,Name,Value)
```

Description

`[A1,...,Am] = cellfun(func,C1,...,Cn)` calls the function specified by function handle `func` and passes elements from cell arrays `C1,...,Cn`, where `n` is the number of inputs to function `func`. Output arrays `A1,...,Am`, where `m` is the number of outputs from function `func`, contain the combined outputs from the function calls. The `i`th iteration corresponds to the syntax `[A1(i),...,Am(i)] = func(C{i},...,Cn{i})`. The `cellfun` function does not perform the calls to function `func` in a specific order.

`[A1,...,Am] = cellfun(func,C1,...,Cn,Name,Value)` calls function `func` with additional options specified by one or more `Name,Value` pair arguments. Possible values for `Name` are `'UniformOutput'` or `'ErrorHandler'`.

Input Arguments**func**

Handle to a function that accepts `n` input arguments and returns `m` output arguments.

If function `func` corresponds to more than one function file (that is, if `func` represents a set of overloaded functions), MATLAB determines which function to call based on the class of the input arguments.

Backward Compatibility

`cellfun` accepts function name strings for function `func`, rather than a function handle, for these function names: `isempty`, `islogical`, `isreal`, `length`, `ndims`, `prodofsize`, `size`, `isclass`. Enclose the function name in single quotes.

If you specify a function name string rather than a function handle:

- `cellfun` does not call any overloaded versions of the function.

- The `size` and `isclass` functions require additional inputs to the `cellfun` function:

`A = cellfun('size', C, k)` returns the size along the `k`th dimension of each element of `C`.

`A = cellfun('isclass', C, classname)` returns logical 1 (true) for each element of `C` that matches the `classname` string. This syntax returns logical 0 (false) for objects that are a subclass of `classname`.

C1,...,Cn

Cell arrays that contain the `n` inputs required for function `func`. Each cell array must have the same dimensions.

Name-Value Pair Arguments

Specify optional comma-separated pairs of `Name, Value` arguments. `Name` is the argument name and `Value` is the corresponding value. `Name` must appear inside single quotes (' '). You can specify several name and value pair arguments in any order as `Name1, Value1, ..., NameN, ValueN`.

'UniformOutput'

Logical value, as follows:

- | | |
|------------------------|--|
| <code>true</code> (1) | Indicates that for all inputs, each output from function <code>func</code> is a cell array or a scalar value that is always of the same type and size. The <code>cellfun</code> function combines the outputs in arrays <code>A1, ..., Am</code> , where <code>m</code> is the number of function outputs. Each output array is of the same type as the individual function outputs. |
| <code>false</code> (0) | Requests that the <code>cellfun</code> function combine the outputs into cell arrays <code>A1, ..., Am</code> . The outputs of function <code>func</code> can be of any size or type. |

Default: `true`

'ErrorHandler'

Handle to a function that catches any errors that occur when MATLAB attempts to execute function `func`. Define this function so that it rethrows the error or returns valid outputs for function `func`.

MATLAB calls the specified error-handling function with two input arguments:

- A structure with these fields:

<code>identifier</code>	Error identifier.
<code>message</code>	Error message text.
<code>index</code>	Linear index corresponding to the element of the input cell array at the time of the error.

- The set of input arguments to function `func` at the time of the error.

Output Arguments**A1,...,Am**

Arrays that collect the m outputs from function `func`. Each array A is the same size as each of the inputs C_1, \dots, C_n .

Function `func` can return output arguments of different classes. However, if `UniformOutput` is true (the default):

- The individual outputs from function `func` must be scalar values (numeric, logical, character, or structure) or cell arrays.
- The class of a particular output argument must be the same for each set of inputs. The class of the corresponding output array is the same as the class of the outputs from function `func`.

Examples

Compute the mean of each vector in cell array `C`.

```
C = {1:10, [2; 4; 6], []};
```

```
averages = cellfun(@mean, C)
```

This code returns

```
averages =  
    5.5000    4.0000    NaN
```

Compute the size of each array in C, created in the previous example.

```
[nrows, ncols] = cellfun(@size, C)
```

This code returns

```
nrows =  
     1     3     0  
ncols =  
    10     1     0
```

Create a cell array that contains strings, and abbreviate those strings to the first three characters. Because the output strings are nonscalar, set `UniformOutput` to `false`.

```
days = {'Monday', 'Tuesday', 'Wednesday', 'Thursday', 'Friday'};  
abbrev = cellfun(@(x) x(1:3), days, 'UniformOutput', false)
```

The syntax `@(x)` creates an anonymous function. This code returns

```
abbrev =  
    'Mon'    'Tue'    'Wed'    'Thu'    'Fri'
```

Compute the covariance between arrays in two cell arrays C and D. Because the covariance output is nonscalar, set `UniformOutput` to `false`.

```
c1 = rand(5,1); c2 = rand(10,1); c3 = rand(15,1);  
d1 = rand(5,1); d2 = rand(10,1); d3 = rand(15,1);
```

```
C = {c1, c2, c3};
D = {d1, d2, d3};

covCD = cellfun(@cov, C, D, 'UniformOutput', false)
```

This code returns

```
covCD =
    [2x2 double]    [2x2 double]    [2x2 double]
```

Define and call a custom error handling function.

```
function result = errorfun(S, varargin)
    warning(S.identifier, S.message);
    result = NaN;
end

A = {rand(3)};
B = {rand(5)};
AgtB = cellfun(@(x,y) x > y, A, B, 'ErrorHandler', @errorfun, ...
    'UniformOutput', false)
```

See Also

[arrayfun](#) | [spfun](#) | [function_handle](#) | [cell2mat](#)

cellplot

Purpose Graphically display structure of cell array

Syntax
`cellplot(c)`
`cellplot(c, 'legend')`
`handles = cellplot(c)`

Description `cellplot(c)` displays a figure window that graphically represents the contents of `c`. Filled rectangles represent elements of vectors and arrays, while scalars and short text strings are displayed as text.

`cellplot(c, 'legend')` places a colorbar next to the plot labelled to identify the data types in `c`.

`handles = cellplot(c)` displays a figure window and returns a vector of surface handles.

Limitations The `cellplot` function can display only two-dimensional cell arrays.

Examples Consider a 2-by-2 cell array containing a matrix, a vector, and two text strings:

```
c{1,1} = '2-by-2';  
c{1,2} = 'eigenvalues of eye(2)';  
c{2,1} = eye(2);  
c{2,2} = eig(eye(2));
```

The command `cellplot(c)` produces

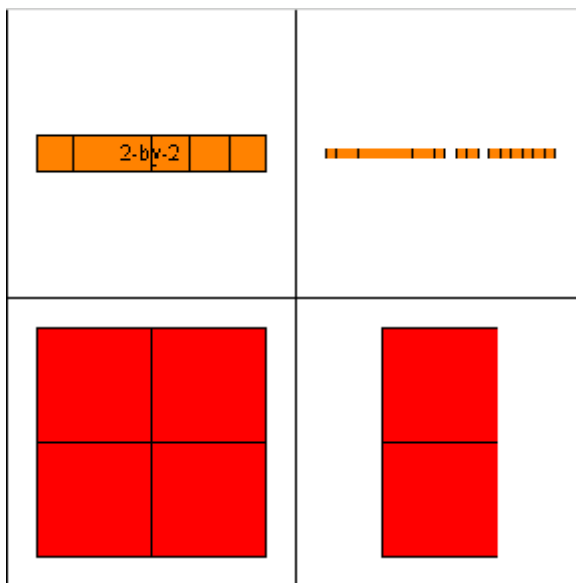
**See Also**`celldisp`**How To**

- “Export Cell Array to Text File”

cellstr

Purpose Create cell array of strings from character array

Syntax `c = cellstr(S)`

Description `c = cellstr(S)` places each row of the character array `S` into separate cells of `c`. Any trailing spaces in the rows of `S` are removed.

Use the `char` function to convert back to a string matrix.

Examples Given the string matrix

```
S = ['abc '; 'defg'; 'hi  ']
```

```
S =  
    abc  
    defg  
    hi
```

```
whos S  
  Name      Size      Bytes  Class  
  S          3x4          24   char array
```

The following command returns a 3-by-1 cell array.

```
c = cellstr(S)
```

```
c =  
    'abc'  
    'defg'  
    'hi'
```

```
whos c  
  Name      Size      Bytes  Class  
  c          3x1          198   cell array
```

See Also `iscellstr` | `strings` | `char` | `isstrprop` | `strsplit`

Purpose

Conjugate gradients squared method

Syntax

```
x = cgs(A,b)
cgs(A,b,tol)
cgs(A,b,tol,maxit)
cgs(A,b,tol,maxit,M)
cgs(A,b,tol,maxit,M1,M2)
cgs(A,b,tol,maxit,M1,M2,x0)
[x,flag] = cgs(A,b,...)
[x,flag,relres] = cgs(A,b,...)
[x,flag,relres,iter] = cgs(A,b,...)
[x,flag,relres,iter,resvec] = cgs(A,b,...)
```

Description

`x = cgs(A,b)` attempts to solve the system of linear equations $A*x = b$ for x . The n -by- n coefficient matrix A must be square and should be large and sparse. The column vector b must have length n . You can specify A as a function handle, `afun`, such that `afun(x)` returns $A*x$.

“Parameterizing Functions” explains how to provide additional parameters to the function `afun`, as well as the preconditioner function `mfun` described below, if necessary.

If `cgs` converges, a message to that effect is displayed. If `cgs` fails to converge after the maximum number of iterations or halts for any reason, a warning message is printed displaying the relative residual $\text{norm}(b-A*x) / \text{norm}(b)$ and the iteration number at which the method stopped or failed.

`cgs(A,b,tol)` specifies the tolerance of the method, `tol`. If `tol` is `[]`, then `cgs` uses the default, $1e-6$.

`cgs(A,b,tol,maxit)` specifies the maximum number of iterations, `maxit`. If `maxit` is `[]` then `cgs` uses the default, $\min(n,20)$.

`cgs(A,b,tol,maxit,M)` and `cgs(A,b,tol,maxit,M1,M2)` use the preconditioner M or $M = M1*M2$ and effectively solve the system $\text{inv}(M)*A*x = \text{inv}(M)*b$ for x . If M is `[]` then `cgs` applies no preconditioner. M can be a function handle `mfun` such that `mfun(x)` returns $M \setminus x$.

`cgs(A,b,tol,maxit,M1,M2,x0)` specifies the initial guess `x0`. If `x0` is `[]`, then `cgs` uses the default, an all-zero vector.

`[x,flag] = cgs(A,b,...)` returns a solution `x` and a flag that describes the convergence of `cgs`.

Flag	Convergence
0	<code>cgs</code> converged to the desired tolerance <code>tol</code> within <code>maxit</code> iterations.
1	<code>cgs</code> iterated <code>maxit</code> times but did not converge.
2	Preconditioner <code>M</code> was ill-conditioned.
3	<code>cgs</code> stagnated. (Two consecutive iterates were the same.)
4	One of the scalar quantities calculated during <code>cgs</code> became too small or too large to continue computing.

Whenever `flag` is not 0, the solution `x` returned is that with minimal norm residual computed over all the iterations. No messages are displayed if the `flag` output is specified.

`[x,flag,relres] = cgs(A,b,...)` also returns the relative residual `norm(b-A*x)/norm(b)`. If `flag` is 0, then `relres <= tol`.

`[x,flag,relres,iter] = cgs(A,b,...)` also returns the iteration number at which `x` was computed, where `0 <= iter <= maxit`.

`[x,flag,relres,iter,resvec] = cgs(A,b,...)` also returns a vector of the residual norms at each iteration, including `norm(b-A*x0)`.

Examples

Using `cgs` with a Matrix Input

```
A = gallery('wilk',21);
b = sum(A,2);
tol = 1e-12; maxit = 15;
M1 = diag([10:-1:1 1 1:10]);
x = cgs(A,b,tol,maxit,M1);
```

displays the message

```
cgs converged at iteration 13 to a solution with
relative residual 2.4e-016.
```

Using cgs with a Function Handle

This example replaces the matrix A in the previous example with a handle to a matrix-vector product function `afun`, and the preconditioner $M1$ with a handle to a backsolve function `mfun`. The example is contained in the file `run_cgs` that

- Calls `cgs` with the function handle `@afun` as its first argument.
- Contains `afun` as a nested function, so that all variables in `run_cgs` are available to `afun` and `mfun`.

The following shows the code for `run_cgs`:

```
function x1 = run_cgs
n = 21;
b = afun(ones(n,1));
tol = 1e-12; maxit = 15;
x1 = cgs(@afun,b,tol,maxit,@mfun);

    function y = afun(x)
        y = [0; x(1:n-1)] + ...
            [((n-1)/2:-1:0)'; (1:(n-1)/2)'].*x + ...
            [x(2:n); 0];
    end

    function y = mfun(r)
        y = r ./ [((n-1)/2:-1:1)'; 1; (1:(n-1)/2)'];
    end
end
```

When you enter

```
x1 = run_cgs
```

MATLAB software returns

```
cgs converged at iteration 13 to a solution with
relative residual 2.4e-016.
```

Using cgs with a Preconditioner.

This example demonstrates the use of a preconditioner.

Load west0479, a real 479-by-479 nonsymmetric sparse matrix.

```
load west0479;
A = west0479;
```

Define **b** so that the true solution is a vector of all ones.

```
b = full(sum(A,2));
```

Set the tolerance and maximum number of iterations.

```
tol = 1e-12; maxit = 20;
```

Use **cgs** to find a solution at the requested tolerance and number of iterations.

```
[x0,f10,rr0,it0,rv0] = cgs(A,b,tol,maxit);
```

f10 is 1 because **cgs** does not converge to the requested tolerance $1e-12$ within the requested 20 iterations. In fact, the behavior of **cgs** is so poor that the initial guess ($x_0 = \text{zeros}(\text{size}(A,2),1)$) is the best solution and is returned as indicated by $it_0 = 0$. MATLAB stores the residual history in **rv0**.

Plot the behavior of **cgs**.

```
semilogy(0:maxit,rv0/norm(b),'-o');
xlabel('Iteration number');
ylabel('Relative residual');
```

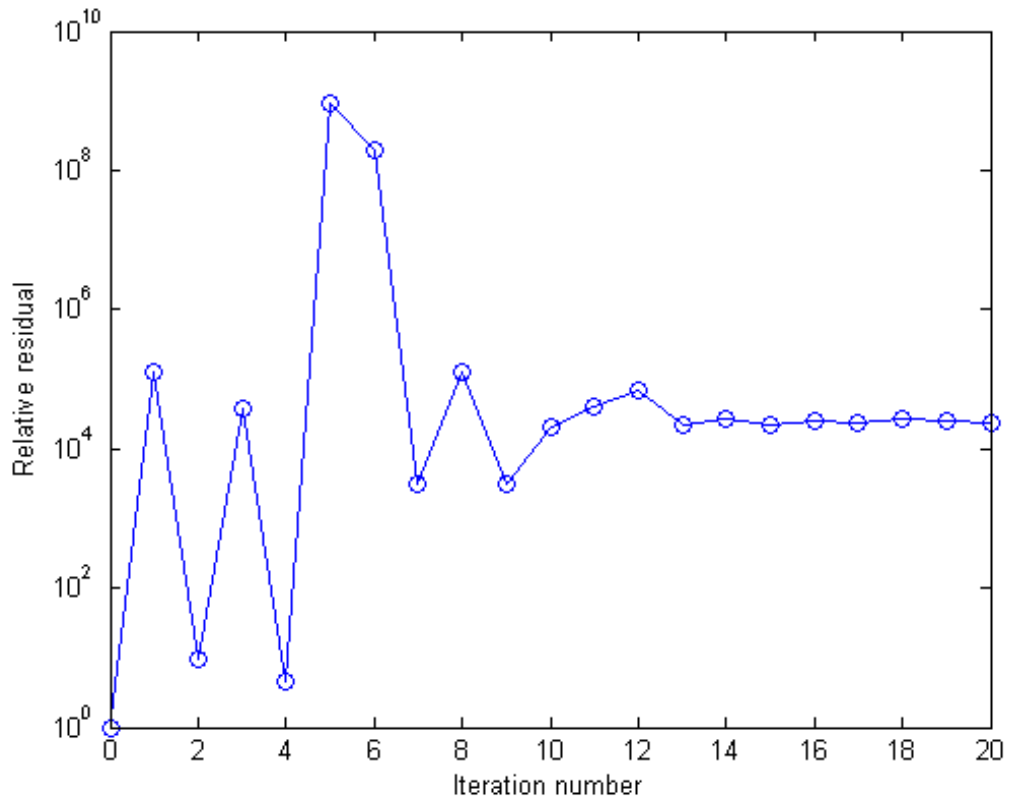

The plot shows that the solution does not converge. You can use a preconditioner to improve the outcome.

Create a preconditioner with `ilu`, since A is nonsymmetric.

```
[L,U] = ilu(A,struct('type','ilutp','droptol',1e-5));
```

Error using `ilu`

There is a pivot equal to zero. Consider decreasing the drop tolerance or consider using the 'udiag' option.

MATLAB cannot construct the incomplete LU as it would result in a singular factor, which is useless as a preconditioner.

You can try again with a reduced drop tolerance, as indicated by the error message.

```
[L,U] = ilu(A,struct('type','ilutp','droptol',1e-6));  
[x1,f11,rr1,it1,rv1] = cgs(A,b,tol,maxit,L,U);
```

f11 is 0 because cgs drives the relative residual to $4.3851e-014$ (the value of rr1). The relative residual is less than the prescribed tolerance of $1e-12$ at the third iteration (the value of it1) when preconditioned by the incomplete LU factorization with a drop tolerance of $1e-6$. The output rv1(1) is norm(b) and the output rv1(14) is norm(b-A*x2).

You can follow the progress of cgs by plotting the relative residuals at each iteration starting from the initial estimate (iterate number 0).

```
semilogy(0:it1,rv1/norm(b),'-o');  
xlabel('Iteration number');  
ylabel('Relative residual');
```

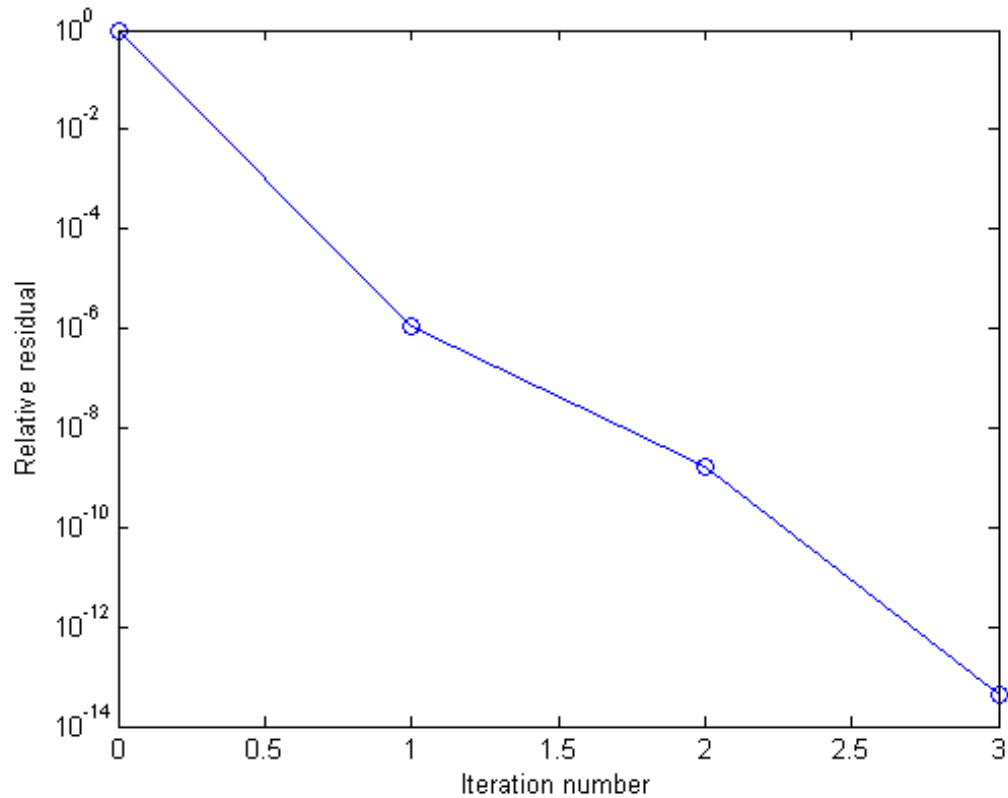

References

- [1] Barrett, R., M. Berry, T. F. Chan, et al., *Templates for the Solution of Linear Systems: Building Blocks for Iterative Methods*, SIAM, Philadelphia, 1994.
- [2] Sonneveld, Peter, "CGS: A fast Lanczos-type solver for nonsymmetric linear systems," *SIAM J. Sci. Stat. Comput.*, January 1989, Vol. 10, No. 1, pp. 36–52.

See Also

`bicg` | `bicgstab` | `function_handle` | `gmres` | `lsqr` | `ilu` | `minres` |
`pcg` | `qmr` | `symmlq` | `mldivide`

Purpose Convert to character array (string)

Syntax

```
S = char(X)
S = char(C)
S = char(T1,T2,...,TN)
```

Description `S = char(X)` converts array `X` of nonnegative integer codes into a character array. Valid codes range from 0 to 65535, where codes 0 through 127 correspond to 7-bit ASCII characters. The characters that MATLAB can process (other than 7-bit ASCII characters) depend upon your current locale setting. To convert characters into a numeric array, use the `double` function.

`S = char(C)`, when `C` is a cell array of strings, places each element of `C` into the rows of the character array `s`. Use `cellstr` to convert back.

`S = char(T1,T2,...,TN)` forms the character array `S` containing the text strings `T1`, `T2`, ..., `TN` as rows, automatically padding each string with blanks to form a valid matrix. Each text parameter, `Ti`, can itself be a character array. This allows the creation of arbitrarily large character arrays. Empty strings are significant.

Examples **Convert Integers to Characters**

Create a 3-by-32 array of the printable ASCII characters.

```
asc = char(reshape(32:127,32,3)')
```

```
asc =
```

```
! "#$%&'()*+,-./0123456789:;<=>?
@ABCDEFGHIJKLMNopqrstuvwxyz[\]^_
`abcdefghijklmnopqrstuvwxyz{|}~
```

See Also `ischar` | `isletter` | `isspace` | `isstrprop` | `cellstr` | `iscellstr` | `get` | `set` | `strings` | `text`

Tutorials

- “How the MATLAB Process Uses Locale Settings”

Purpose	Check MATLAB code files for possible problems
Alternatives	For information on using the graphical user interface for checking code, see “Check Code for Errors and Warnings”.
Syntax	<pre>checkcode('filename') checkcode('filename', '-config=settings.txt') checkcode('filename', '-config=factory') inform=checkcode('filename', '-struct') msg=checkcode('filename', '-string') [inform, filepaths]=checkcode('filename') inform=checkcode('filename', '-id') inform=checkcode('filename', '-fullpath') inform=checkcode('filename', '-notok') checkcode('filename', '-cyc') checkcode('filename', '-codegen') checkcode('filename', '-eml')</pre>

Description `checkcode('filename')` displays messages, sometimes referred to as Code Analyzer messages, about `filename`, where the message reports potential problems and opportunities for code improvement. The line number in the message is a hyperlink that opens the file in the Editor, scrolled to that line. If `filename` is a cell array, information is displayed for each file. For `checkcode(F1,F2,F3,...)`, where each input is a character array, MATLAB software displays information about each input file name. You cannot combine cell arrays and character arrays of file names. Note that the exact text of the `checkcode` messages is subject to some change between versions.

`checkcode('filename', '-config=settings.txt')` overrides the default active settings file with the settings that enable or suppress messages as indicated in the specified `settings.txt` file.

Note If used, you must specify the full path to the `settings.txt` file specified with the `-config` option.

checkcode

For information about creating a `settings.txt` file, see “Save and Reuse Code Analyzer Message Settings”. If you specify an invalid file, `checkcode` returns a message indicating that it cannot open or read the file you specified. In that case, `checkcode` uses the factory default settings.

`checkcode('filename', '-config=factory')` ignores all settings files and uses the factory default preference settings.

`inform=checkcode('filename', '-struct')` returns the information in a structure array whose length is the number of messages found. The structure has the fields that follow.

Field	Description
<code>message</code>	Message describing the suspicious construct that code analysis caught.
<code>line</code>	Vector of file line numbers to which the message refers.
<code>column</code>	Two-column array of file columns (column extents) to which the message applies. The first column of the array specifies the column in the Editor where the message begins. The second column of the array specifies the column in the Editor where the message ends. There is one row in the two-column array for each occurrence of a message.

If you specify multiple file names as input, or if you specify a cell array as input, `inform` contains a cell array of structures.

`msg=checkcode('filename', '-string')` returns the information as a string to the variable `msg`. If you specify multiple file names as input, or if you specify a cell array as input, `msg` contains a string where each file’s information is separated by 10 equal sign characters (=), a space, the file name, a space, and 10 equal sign characters.

If you omit the `-struct` or `-string` argument and you specify an output argument, the default behavior is `-struct`. If you omit the argument

and there are no output arguments, the default behavior is to display the information to the command line.

`[inform,filepath]=checkcode('filename')` additionally returns `filepath`, the absolute paths to the file names, in the same order as you specified them.

`inform=checkcode('filename','-id')` requests the message ID, where ID is a string of the form ABC... When returned to a structure, the output also has the `id` field, which is the ID associated with the message.

`inform=checkcode('filename','-fullpath')` assumes that the input file names are absolute paths, so that `checkcode` does not try to locate them.

`inform=checkcode('filename','-notok')` runs `checkcode` for all lines in `filename`, even those lines that end with the `checkcode` suppression directive, `%#ok`.

`checkcode('filename','-cyc')` displays the McCabe complexity (also referred to as cyclomatic complexity) of each function in the file. Higher McCabe complexity values indicate higher complexity, and there is some evidence to suggest that programs with higher complexity values are more likely to contain errors. Frequently, you can lower the complexity of a function by dividing it into smaller, simpler functions. In general, smaller complexity values indicate programs that are easier to understand and modify. Some people advocate splitting up programs that have a complexity rating over 10.

`checkcode('filename','-codegen')` enables code generation messages for display in the Command Window.

`checkcode('filename','-em1')` `-em1` is not recommended. Use `-codegen` instead.

Examples

The following examples use `lengthofline.m`, which is a sample file with MATLAB code that can be improved. You can find it in `matlabroot/help/techdoc/matlab_env/examples`. If you want to run

the examples, save a copy of `lengthofline.m` to a location on your MATLAB path.

Running checkcode on a File with No Options

To run `checkcode` on the example file, `lengthofline.m`, run

```
checkcode('lengthofline')
```

MATLAB displays the Code Analyzer messages for `lengthofline.m` in the Command Window:

```
L 22 (C 1-9): The value assigned here to variable 'nohandle' might never be used.
L 23 (C 12-15): NUMEL(x) is usually faster than PROD(SIZE(x)).
L 24 (C 5-11): 'notline' might be growing inside a loop. Consider preallocating for speed.
L 24 (C 44-49): Use STRCMP(str1,str2) instead of using LOWER in a call to STRCMP.
L 28 (C 12-15): NUMEL(x) is usually faster than PROD(SIZE(x)).
L 34 (C 13-16): 'data' might be growing inside a loop. Consider preallocating for speed.
L 34 (C 24-31): Use dynamic fieldnames with structures instead of GETFIELD. Type 'doc struct' for more info.
L 38 (C 29): Use || instead of | as the OR operator in (scalar) conditional statements.
L 39 (C 47): Use || instead of | as the OR operator in (scalar) conditional statements.
L 40 (C 47): Use || instead of | as the OR operator in (scalar) conditional statements.
L 42 (C 13-16): 'data' might be growing inside a loop. Consider preallocating for speed.
L 43 (C 13-15): 'dim' might be growing inside a loop. Consider preallocating for speed.
L 45 (C 13-15): 'dim' might be growing inside a loop. Consider preallocating for speed.
L 48 (C 52): There may be a parenthesis imbalance around here.
L 48 (C 53): There may be a parenthesis imbalance around here.
L 48 (C 54): There may be a parenthesis imbalance around here.
L 48 (C 55): There may be a parenthesis imbalance around here.
L 49 (C 17): Terminate statement with semicolon to suppress output (in functions).
L 49 (C 23): Use of brackets [] is unnecessary. Use parentheses to group, if needed.
```

For details about these messages and how to improve the code, see “Changing Code Based on Code Analyzer Messages” in the MATLAB Desktop Tools and Development Environment documentation.

Running checkcode with Options to Show IDs and Return Results to a Structure

To store the results to a structure and include message IDs, run

```
inform=checkcode('lengthofline', '-id')
```

MATLAB returns

```
inform =
```

```
19x1 struct array with fields:
```

```
    message  
     line  
   column  
     id
```

To see values for the first message, run

```
inform(1)
```

MATLAB displays

```
ans =
```

```
    message: 'The value assigned here to variable 'nohandle' might never be used.'  
         line: 22  
    column: [1 9]  
         id: 'NASGU'
```

Here, the message is for the value that appears on line 22 that extends from column 1–9 in the file.NASGU is the ID for the message 'The value assigned here to variable 'nohandle' might never be used.'.

Displaying McCabe Complexity with checkcode

To display the McCabe complexity of a MATLAB code file, run checkcode with the `-cyc` option, as shown in the following example (assuming you have saved `lengthofline.m` to a local folder).

```
checkcode lengthofline.m -cyc
```

Results displayed in the Command Window show the McCabe complexity of the file, followed by the Code Analyzer messages, as shown here:

```
L 1 (C 23-34): The McCabe complexity of 'lengthofline' is 12.
L 22 (C 1-9): The value assigned here to variable 'nohandle' might never be used.
L 23 (C 12-15): NUMEL(x) is usually faster than PROD(SIZE(x)).
L 24 (C 5-11): 'notline' might be growing inside a loop. Consider preallocating for speed.
L 24 (C 44-49): Use STRCMPI(str1,str2) instead of using UPPER/LOWER in a call to STRCMP.
L 28 (C 12-15): NUMEL(x) is usually faster than PROD(SIZE(x)).
L 34 (C 13-16): 'data' might be growing inside a loop. Consider preallocating for speed.
L 34 (C 24-31): Use dynamic fieldnames with structures instead of GETFIELD. Type 'doc struct' for more in
L 38 (C 29): Use || instead of | as the OR operator in (scalar) conditional statements.
L 39 (C 47): Use || instead of | as the OR operator in (scalar) conditional statements.
L 40 (C 47): Use || instead of | as the OR operator in (scalar) conditional statements.
L 42 (C 13-16): 'data' might be growing inside a loop. Consider preallocating for speed.
L 43 (C 13-15): 'dim' might be growing inside a loop. Consider preallocating for speed.
L 45 (C 13-15): 'dim' might be growing inside a loop. Consider preallocating for speed.
L 48 (C 52): There may be a parenthesis imbalance around here.
L 48 (C 53): There may be a parenthesis imbalance around here.
L 48 (C 54): There may be a parenthesis imbalance around here.
L 48 (C 55): There may be a parenthesis imbalance around here.
L 49 (C 17): Terminate statement with semicolon to suppress output (in functions).
L 49 (C 23): Use of brackets [] is unnecessary. Use parentheses to group, if needed.
```

See Also

`mlintrpt`, `profile`

How To

- For information on the suppression directive, `%#ok`, and suppressing messages from within your program, see “Adjust Code Analyzer Message Indicators and Messages”.

Purpose

Check files into source control system (UNIX platforms)

Syntax

```
checkin('filename', 'comments', 'comment_text')
checkin({'filename1', 'filename2'}, 'comments', 'comment_text')
checkin('filename', 'comments',
'comment_text', 'option', 'value')
```

Description

`checkin('filename', 'comments', 'comment_text')` checks in the file named `filename` to the source control system. Use the full path for `filename` and include the file extension. You must save the file before checking it in, but the file can be open or closed. The `comment_text` is a MATLAB string containing checkin comments for the source control system. You must supply **comments** and `comment_text`.

`checkin({'filename1', 'filename2'}, 'comments', 'comment_text')` checks in the files `filename1` through `filename` to the source control system. Use the full paths for the files and include file extensions. Comments apply to all files checked in.

`checkin('filename', 'comments', 'comment_text', 'option', 'value')` provides additional checkin options. For multiple file names, use an array of strings instead of `filename`, that is, `{'filename1', 'filename2', ...}`. Options apply to all file names. The *option* and *value* arguments are shown in the following table.

option Argument	value Argument	Purpose
'force'	'on'	filename is checked in even if the file has not changed since it was checked out.
'force'	'off' (default)	filename is not checked in if there were no changes since checkout.

checkin

option Argument	value Argument	Purpose
'lock'	'on'	filename is checked in with comments, and is automatically checked out.
'lock'	'off' (default)	filename is checked in with comments but does not remain checked out.

Examples

Check In a File

Check the file `/myserver/myfiles/clock.m` into the source control system, with the comment `Adjustment for leapyear`:

```
checkin('/myserver/myfiles/clock.m','comments',...  
'Adjustment for leapyear')
```

Check In Multiple Files

Check two files into the source control system, using the same comment for each:

```
checkin({'/myserver/myfiles/clock.m', ...  
'/myserver/myfiles/calendar.m'}, 'comments', ...  
'Adjustment for leapyear')
```

Check In a File and Keep It Checked Out

Check the file `/myserver/myfiles/clock.m` into the source control system and keep the file checked out:

```
checkin('/myserver/myfiles/clock.m','comments',...  
'Adjustment for leapyear','lock','on')
```

See Also

`checkout` | `cmopts` | `undocheckout` | `verctrl`

How To

- “Check In Files (UNIX Platforms)”

Purpose Check files out of source control system (UNIX platforms)

Syntax

```
checkout('filename')
checkout({'filename1','filename2', ...})
checkout('filename','option','value',...)
```

Description `checkout('filename')` checks out the file named `filename` from the source control system. Use the full path for `filename` and include the file extension. The file can be open or closed when you use `checkout`.

`checkout({'filename1','filename2', ...})` checks out the files named `filename1` through `filename2` from the source control system. Use the full paths for the files and include the file extensions.

`checkout('filename','option','value',...)` provides additional `checkout` options. For multiple file names, use an array of strings instead of `filename`, that is, `{'filename1','filename2', ...}`. Options apply to all file names. The *option* and *value* arguments are shown in the following table.

option Argument	value Argument	Purpose
'force'	'on'	The checkout is forced, even if you already have the file checked out. This is effectively an <code>undocheckout</code> followed by a <code>checkout</code> .
'force'	'off' (default)	Prevents you from checking out the file if you already have it checked out.

checkout

option Argument	value Argument	Purpose
'lock'	'on' (default)	The checkout gets the file, allows you to write to it, and locks the file so that access to the file for others is read only.
'lock'	'off'	The checkout gets a read-only version of the file, allowing another user to check out the file for updating. You do not have to check the file in after checking it out with this option.
'revision'	'version_num'	Checks out the specified revision of the file.

If you end the MATLAB session, the file remains checked out. You can check in the file from within the MATLAB desktop during a later session, or directly from your source control system.

Examples

Check Out a File

Check out the file `/myserver/myfiles/clock.m` from the source control system:

```
checkout('/myserver/myfiles/clock.m')
```

Check Out Multiple Files

Check out `/matlab/myfiles/clock.m` and `/matlab/myfiles/calendar.m` from the source control system:

```
checkout({'/myserver/myfiles/clock.m', ...
```

```
'/myserver/myfiles/calendar.m'})
```

Force a Checkout, Even If File Is Already Checked Out

Check out `/matlab/myfiles/clock.m` even if `clock.m` is already checked out to you:

```
checkout('/myserver/myfiles/clock.m', 'force', 'on')
```

Check Out Specified Revision of File

Check out revision 1.1 of `clock.m`:

```
checkout('/matlab/myfiles/clock.m', 'revision', '1.1')
```

See Also

`checkin` | `cmopts` | `undocheckout` | `customverctrl` | `verctrl`

How To

- “Check Out Files (UNIX Platforms)”

Purpose Cholesky factorization

Syntax

```
R = chol(A)
L = chol(A, 'lower')
R = chol(A, 'upper')
[R,p] = chol(A)
[L,p] = chol(A, 'lower')
[R,p] = chol(A, 'upper')
[R,p,S] = chol(A)
[R,p,s] = chol(A, 'vector')
[L,p,s] = chol(A, 'lower', 'vector')
[R,p,s] = chol(A, 'upper', 'vector')
```

Description $R = \text{chol}(A)$ produces an upper triangular matrix R from the diagonal and upper triangle of matrix A , satisfying the equation $R' * R = A$. The `chol` function assumes that A is (complex Hermitian) symmetric. If it is not, `chol` uses the (complex conjugate) transpose of the upper triangle as the lower triangle. Matrix A must be positive definite.

$L = \text{chol}(A, 'lower')$ produces a lower triangular matrix L from the diagonal and lower triangle of matrix A , satisfying the equation $L * L' = A$. The `chol` function assumes that A is (complex Hermitian) symmetric. If it is not, `chol` uses the (complex conjugate) transpose of the lower triangle as the upper triangle. When A is sparse, this syntax of `chol` is typically faster. Matrix A must be positive definite. $R = \text{chol}(A, 'upper')$ is the same as $R = \text{chol}(A)$.

$[R,p] = \text{chol}(A)$ for positive definite A , produces an upper triangular matrix R from the diagonal and upper triangle of matrix A , satisfying the equation $R' * R = A$ and p is zero. If A is not positive definite, then p is a positive integer and MATLAB does not generate an error. When A is full, R is an upper triangular matrix of order $q = p - 1$ such that $R' * R = A(1:q, 1:q)$. When A is sparse, R is an upper triangular matrix of size q -by- n so that the L-shaped region of the first q rows and first q columns of $R' * R$ agree with those of A .

$[L,p] = \text{chol}(A, 'lower')$ for positive definite A , produces a lower triangular matrix L from the diagonal and lower triangle of matrix A ,

satisfying the equation $L*L' = A$ and p is zero. If A is not positive definite, then p is a positive integer and MATLAB does not generate an error. When A is full, L is a lower triangular matrix of order $q = p - 1$ such that $L*L' = A(1:q, 1:q)$. When A is sparse, L is a lower triangular matrix of size q -by- n so that the L-shaped region of the first q rows and first q columns of $L*L'$ agree with those of A . $[R, p] = chol(A, 'upper')$ is the same as $[R, p] = chol(A)$.

The following three-output syntaxes require sparse input A .

$[R, p, S] = chol(A)$, when A is sparse, returns a permutation matrix S . Note that the reordering S may differ from that obtained from `amd` since `chol` will slightly change the ordering for increased performance. When $p=0$, R is an upper triangular matrix such that $R'*R = S'*A*S$. When p is not zero, R is an upper triangular matrix of size q -by- n so that the L-shaped region of the first q rows and first q columns of $R'*R$ agree with those of $S'*A*S$. The factor of $S'*A*S$ tends to be sparser than the factor of A .

$[R, p, s] = chol(A, 'vector')$, when A is sparse, returns the permutation information as a vector s such that $A(s, s) = R'*R$, when $p=0$. You can use the 'matrix' option in place of 'vector' to obtain the default behavior.

$[L, p, s] = chol(A, 'lower', 'vector')$, when A is sparse, uses only the diagonal and the lower triangle of A and returns a lower triangular matrix L and a permutation vector s such that $A(s, s) = L*L'$, when $p=0$. As above, you can use the 'matrix' option in place of 'vector' to obtain a permutation matrix. $[R, p, s] = chol(A, 'upper', 'vector')$ is the same as $[R, p, s] = chol(A, 'vector')$.

Note Using `chol` is preferable to using `eig` for determining positive definiteness.

Examples

Example 1

The gallery function provides several symmetric, positive, definite matrices.

```
A=gallery('moler',5)
```

```
A =
```

```
    1   -1   -1   -1   -1
   -1    2    0    0    0
   -1    0    3    1    1
   -1    0    1    4    2
   -1    0    1    2    5
```

```
C=chol(A)
```

```
ans =
```

```
    1   -1   -1   -1   -1
    0    1   -1   -1   -1
    0    0    1   -1   -1
    0    0    0    1   -1
    0    0    0    0    1
```

```
isequal(C'*C,A)
```

```
ans =
```

```
    1
```

For sparse input matrices, chol returns the Cholesky factor.

```
N = 100;
A = gallery('poisson', N);
```

N represents the number of grid points in one direction of a square N-by-N grid. Therefore, A is N^2 by N^2 .

```
L = chol(A, 'lower');
D = norm(A - L*L', 'fro');
```

The value of D will vary somewhat among different versions of MATLAB but will be on order of 10^{-14} .

Example 2

The binomial coefficients arranged in a symmetric array create a positive definite matrix.

```
n = 5;
X = pascal(n)
X =
    1    1    1    1    1
    1    2    3    4    5
    1    3    6   10   15
    1    4   10   20   35
    1    5   15   35   70
```

This matrix is interesting because its Cholesky factor consists of the same coefficients, arranged in an upper triangular matrix.

```
R = chol(X)
R =
    1    1    1    1    1
    0    1    2    3    4
    0    0    1    3    6
    0    0    0    1    4
    0    0    0    0    1
```

Destroy the positive definiteness (and actually make the matrix singular) by subtracting 1 from the last element.

```
X(n,n) = X(n,n) - 1
X =
    1    1    1    1    1
    1    2    3    4    5
```

chol

```
1   3   6  10  15
1   4  10  20  35
1   5  15  35  69
```

Now an attempt to find the Cholesky factorization of X fails.

```
chol(X)
Error using chol
Matrix must be positive definite.
```

See Also

[ichol](#) | [cholupdate](#)

Purpose Rank 1 update to Cholesky factorization

Syntax

```
R1 = cholupdate(R,x)
R1 = cholupdate(R,x,'+')
R1 = cholupdate(R,x,'-')
[R1,p] = cholupdate(R,x,'-')
```

Description

`R1 = cholupdate(R,x)` where `R = chol(A)` is the original Cholesky factorization of `A`, returns the upper triangular Cholesky factor of $A + x*x'$, where `x` is a column vector of appropriate length. `cholupdate` uses only the diagonal and upper triangle of `R`. The lower triangle of `R` is ignored.

`R1 = cholupdate(R,x,'+')` is the same as `R1 = cholupdate(R,x)`.

`R1 = cholupdate(R,x,'-')` returns the Cholesky factor of $A - x*x'$. An error message reports when `R` is not a valid Cholesky factor or when the downdated matrix is not positive definite and so does not have a Cholesky factorization.

`[R1,p] = cholupdate(R,x,'-')` will not return an error message. If `p` is 0, `R1` is the Cholesky factor of $A - x*x'$. If `p` is greater than 0, `R1` is the Cholesky factor of the original `A`. If `p` is 1, `cholupdate` failed because the downdated matrix is not positive definite. If `p` is 2, `cholupdate` failed because the upper triangle of `R` was not a valid Cholesky factor.

Tips `cholupdate` works only for full matrices.

Examples

```
A = pascal(4)
A =

     1     1     1     1
     1     2     3     4
     1     3     6    10
     1     4    10    20

R = chol(A)
R =
```

cholupdate

```
      1      1      1      1
      0      1      2      3
      0      0      1      3
      0      0      0      1
x = [0 0 0 1]';
```

This is called a rank one update to A since $\text{rank}(x*x')$ is 1:

```
A + x*x'
ans =
```

```
      1      1      1      1
      1      2      3      4
      1      3      6     10
      1      4     10     21
```

Instead of computing the Cholesky factor with $R1 = \text{chol}(A + x*x')$, we can use cholupdate:

```
R1 = cholupdate(R,x)
R1 =
```

```
  1.0000    1.0000    1.0000    1.0000
         0    1.0000    2.0000    3.0000
         0         0    1.0000    3.0000
         0         0         0    1.4142
```

Next destroy the positive definiteness (and actually make the matrix singular) by subtracting 1 from the last element of A. The downdated matrix is:

```
A - x*x'
ans =
```

```
      1      1      1      1
      1      2      3      4
```

```

1     3     6    10
1     4    10    19

```

Compare chol with cholupdate:

```

R1 = chol(A-x*x')
Error using chol
Matrix must be positive definite.
R1 = cholupdate(R,x,'-')
Error using cholupdate
Downdated matrix must be positive definite.

```

However, subtracting 0.5 from the last element of A produces a positive definite matrix, and we can use cholupdate to compute its Cholesky factor:

```

x = [0 0 0 1/sqrt(2)]';
R1 = cholupdate(R,x,'-')
R1 =
    1.0000    1.0000    1.0000    1.0000
         0    1.0000    2.0000    3.0000
         0         0    1.0000    3.0000
         0         0         0    0.7071

```

Algorithms

cholupdate uses the algorithms from the LINPACK subroutines ZCHUD and ZCHDD. cholupdate is useful since computing the new Cholesky factor from scratch is an $O(N^3)$ algorithm, while simply updating the existing factor in this way is an $O(N^2)$ algorithm.

References

[1] Dongarra, J.J., J.R. Bunch, C.B. Moler, and G.W. Stewart, *LINPACK Users' Guide*, SIAM, Philadelphia, 1979.

See Also

chol | qrupdate

circshift

Purpose Shift array circularly

Compatibility The default behavior of `circshift(A,K)`, where `K` is a scalar, will change in a future release. The new default behavior will be to operate along the first array dimension of `A` whose size does not equal 1. Use `circshift(A,[K 0])` to retain current behavior.

Syntax
`Y = circshift(A,K)`
`Y = circshift(A,K,dim)`

Description `Y = circshift(A,K)` circularly shifts the elements in array `A` by `K` positions. Specify `K` as an integer to shift the rows of `A`, or as a vector of integers to specify the shift amount in each dimension.

`Y = circshift(A,K,dim)` circularly shifts the values in array `A` by `K` positions along dimension `dim`. Inputs `K` and `dim` must be scalars.

Input Arguments

A - Input array

vector | matrix | multidimensional array

Input array, specified as a vector, matrix, or multidimensional array.

Data Types

single | double | int8 | int16 | int32 | int64 | uint8 |
uint16 | uint32 | uint64 | logical | char | struct | table
| cell

Complex Number Support: Yes

K - Shift amount

integer scalar | vector of integers

Shift amount, specified as an integer scalar or vector of integers. If the shift amount is larger than the length of the corresponding dimension in `A`, then the shift circularly wraps to the beginning of that dimension. For example, shifting a 3-element vector by +3 positions will bring its elements back to their original positions.

- If you specify `K` as an integer and do not specify `dim`, then `circshift` shifts the rows of `A` down (positive integer) or up (negative integer).
- If you specify `K` as a vector of integers, each element specifies the shift amount for the N th dimension in `A`. If the N th element in `K` is positive, then the values of `A` are shifted towards the end (positive integer) or beginning (negative integer) of the N th dimension.

dim - Dimension to operate along

positive integer scalar

Dimension to operate along, specified as a positive integer scalar. If no value is specified, the default is `dim = 1`. If you specify `dim`, then `K` must be an integer scalar. Specify `dim = 1` to exchange rows, `dim = 2` to exchange columns, and so on.

Examples**Shift Column Vector Elements**

Create a numeric column vector.

```
A = (1:10)'
```

```
A =
```

```
1
2
3
4
5
6
7
8
9
10
```

Use `circshift` to shift the elements by three positions.

```
Y = circshift(A,3)
```

circshift

```
Y =  
  
     8  
     9  
    10  
     1  
     2  
     3  
     4  
     5  
     6  
     7
```

The result, Y, has the same elements as A but they are in a different order.

Move Characters in Array

Create an array of characters.

```
A = 'racecar'
```

```
A =
```

```
racecar
```

Use `circshift` to shift the characters by three positions in the second dimension.

```
Y = circshift(A,3,2)
```

```
Y =
```

```
carrace
```

The characters are in a different order in Y.

Move Matrix Elements

Create a numeric array with a cluster of ones in the top left.

```
A = [1 1 0 0; 1 1 0 0; 0 0 0 0; 0 0 0 0]
```

```
A =
```

```

     1     1     0     0
     1     1     0     0
     0     0     0     0
     0     0     0     0

```

Use `circshift` to shift the elements of `A` by one position in each dimension.

```
Y = circshift(A,[1 1])
```

```
Y =
```

```

     0     0     0     0
     0     1     1     0
     0     1     1     0
     0     0     0     0

```

The cluster of ones is now in the center of the matrix.

To move the cluster back to its original position, use `circshift` on `Y` with negative shift values.

```
X = circshift(Y,[-1 -1])
```

```
X =
```

```

     1     1     0     0
     1     1     0     0
     0     0     0     0
     0     0     0     0

```

The matrix `X` is equivalent to `A`.

See Also

`fftshift` | `reshape` | `shiftdim` | `permute`

TriRep.circumcenters

Purpose (Will be removed) Circumcenters of specified simplices

Note `circumcenters(TriRep)` will be removed in a future release. Use `circumcenter(triangulation)` instead.

`TriRep` will be removed in a future release. Use `triangulation` instead.

Syntax
`CC = circumcenters(TR, SI)`
`[CC RCC] = circumcenters(TR, SI)`

Description `CC = circumcenters(TR, SI)` returns the coordinates of the circumcenter of each specified simplex `SI`. `CC` is an `m`-by-`n` matrix, where `m` is of length `length(SI)`, the number of specified simplices, and `n` is the dimension of the space where the triangulation resides.

`[CC RCC] = circumcenters(TR, SI)` returns the circumcenters and the corresponding radii of the circumscribed circles or spheres.

Input Arguments

<code>TR</code>	Triangulation object.
<code>SI</code>	Column vector of simplex indices that index into the triangulation matrix <code>TR.Triangulation</code> . If <code>SI</code> is not specified the circumcenter information for the entire triangulation is returned, where the circumcenter associated with simplex <code>i</code> is the <code>i</code> 'th row of <code>CC</code> .

Output Arguments

CC	m-by-n matrix. m is the number of specified simplices and n is the dimension of the space where the triangulation resides. Each row <code>CC(i,:)</code> represents the coordinates of the circumcenter of simplex <code>SI(i)</code> .
RCC	Vector of length <code>length(SI)</code> , the number of specified simplices containing radii of the circumscribed circles or spheres.

Definitions

A simplex is a triangle/tetrahedron or higher-dimensional equivalent.

Examples

Example 1

Load a 2-D triangulation.

```
load trimesh2d
trep = TriRep(tri, x,y)
```

Compute the circumcenters.

```
cc = circumcenters(trep);
triplot(trep);
axis([-50 350 -50 350]);
axis equal;
hold on;
plot(cc(:,1),cc(:,2),'*r');
hold off;
```

The circumcenters represent points on the medial axis of the polygon.

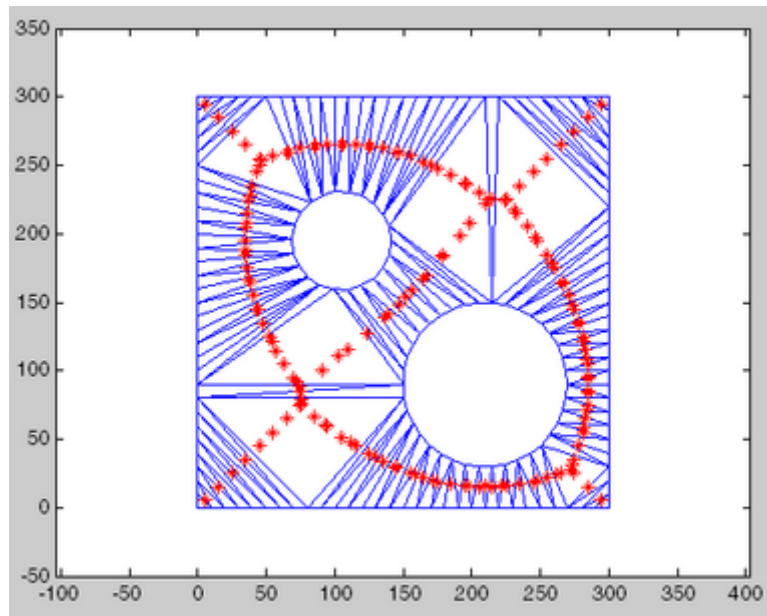

Example 2

Query a 3-D triangulation created with `DelaunayTri`. Compute the circumcenters of the first five tetrahedra.

```
X = rand(10,3);  
dt = DelaunayTri(X);  
cc = circumcenters(dt, [1:5]')
```

See Also

[incenter](#) | [delaunayTriangulation](#) | [triangulation](#)

Purpose	Clear current axes
Syntax	<pre>cla cla reset cla(ax) cla(ax, 'reset')</pre>
Description	<p>cla deletes from the current axes all graphics objects whose handles are not hidden (i.e., their <code>HandleVisibility</code> property is set to <code>on</code>).</p> <p>cla reset deletes from the current axes all graphics objects regardless of the setting of their <code>HandleVisibility</code> property and resets all axes properties, except <code>Position</code> and <code>Units</code>, to their default values.</p> <p>cla(ax) or cla(ax, 'reset') clears the single axes with handle ax.</p>
Tips	<p>The cla command behaves the same way when issued on the command line as it does in callback routines — it does not recognize the <code>HandleVisibility</code> setting of callback. This means that when issued from within a callback routine, cla deletes only those objects whose <code>HandleVisibility</code> property is set to <code>on</code>.</p>
See Also	<code>clf</code> <code>hold</code> <code>newplot</code> <code>reset</code>

clabel

Purpose Contour plot elevation labels

Syntax

```
clabel(C)
clabel(C,h)
clabel(C,v)
clabel(C,h,v)
clabel( __ ,Name,Value)

clabel(C,'manual')
clabel(C,h,'manual')

text_handles = clabel( __ )
```

Description `clabel(C)` labels all contours displayed in the current contour plot. Labels are upright and displayed with '+' symbols. `clabel` randomly selects label positions.

`clabel(C,h)` rotates the labels and inserts them in the contour lines. This syntax inserts only those labels that fit within the contour, depending on the size of the contour.

`clabel(C,v)` labels only the contour levels specified by the vector, `v`.

`clabel(C,h,v)` labels only the contour levels specified by vector `v`, rotates the labels, and inserts them in the contour lines.

`clabel(__ ,Name,Value)` specifies the text object properties and the 'LabelSpacing' contourgroup property, using one or more `Name,Value` pair arguments, in addition to any of the input arguments in previous syntaxes.

`clabel(C,'manual')` places contour labels at locations you select with a mouse. Click the mouse or press the space bar to label the contour

closest to the center of the crosshair. Press the **Return** key while the cursor is within the figure window to terminate labeling.

`clabel(C,h,'manual')` places contour labels at locations you select with a mouse. Press the **Return** key while the cursor is within the figure window to terminate labeling. The labels are rotated and inserted in the contour lines.

`text_handles = clabel(__)` additionally returns an array containing the handles of the text objects created, using any of the input arguments in the previous syntaxes. If you call `clabel` without the `h` argument, `text_handles` also contains the handles of line objects used to create the '+' symbols.

Input Arguments

C - Contour matrix

2-by-n matrix

Contour matrix containing the data that defines the contour lines. `C` is returned by the `contour`, `contour3`, or `contourf` function.

h - Handle to the contourgroup object

value returned by contour functions

Handle to the `contourgroup` object specified as the value returned by the `contour`, `contour3`, or `contourf` function.

v - Contour level values

vector

Contour level values, specified as a row or column vector of individual values.

Example: `[0,10,20]`

Name-Value Pair Arguments

Specify optional comma-separated pairs of `Name,Value` arguments. `Name` is the argument name and `Value` is the corresponding value. `Name` must appear inside single quotes (' '). You can

specify several name and value pair arguments in any order as `Name1,Value1,...,NameN,ValueN`.

Example: `'Color','red','Rotation',45` adds red labels to a contour plot, where each label is rotated 45 degrees.

In addition to the following, you can specify other text object properties using `Name,Value` pair arguments. See [Text Properties](#).

'Color' - Text color

`[0 0 0]` (black) (default) | 3-element RGB vector | string

Text color, specified as the comma-separated pair consisting of `'Color'` and a 3-element RGB vector or a string containing the short or long name of the color. The RGB vector is a 3-element row vector whose elements specify the intensities of the red, green, and blue components of the color. The intensities must be in the range `[0 1]`.

The following table lists the predefined colors and their RGB equivalents.

RGB Value	Short Name	Long Name
<code>[1 1 0]</code>	y	yellow
<code>[1 0 1]</code>	m	magenta
<code>[0 1 1]</code>	c	cyan
<code>[1 0 0]</code>	r	red
<code>[0 1 0]</code>	g	green
<code>[0 0 1]</code>	b	blue
<code>[1 1 1]</code>	w	white
<code>[0 0 0]</code>	k	black

Example: `'Color',[0 1 0]`

Example: `'Color','green'`

'FontName' - Font name

'Helvetica' (default) | string | 'FixedWidth'

Font name, specified as the comma-separated pair consisting of 'FontName' and a string. The string specifies the name of the font to use for the text object. To display and print properly, this must be a font that your system supports.

To use a fixed-width font that looks good in any locale, use the case-sensitive string 'FixedWidth'. This eliminates the need to hard-code the name of a fixed-width font, which might not display text properly on systems that do not use ASCII character encoding.

Example: 'FontName', 'Courier'

'FontSize' - Font size

10 points (default) | scalar

Font size, specified as the comma-separated pair consisting of 'FontSize' and a scalar in units determined by the FontUnits property. The default value for FontUnits is points.

Example: 'FontSize', 12.5

'FontUnits' - Font size units

'points' (default) | 'normalized' | 'inches' | 'centimeters' | 'pixels'

Font size units, specified as the comma-separated pair consisting of 'FontUnits' and one of the following strings:

- 'points'
- 'normalized'
- 'inches'
- 'centimeters'
- 'pixels'

When the value of FontUnits is 'normalized', MATLAB interprets the value of FontSize as a fraction of the height of the parent axes. When you resize the axes, MATLAB modifies the screen FontSize

accordingly. points, inches, centimeters, and pixels are absolute units. 1 point = $\frac{1}{72}$ inch

Note When setting both the `FontSize` and the `FontUnits`, you must set the `FontUnits` property first so that MATLAB can correctly interpret the specified `FontSize`. For example, to set the font size to 0.3 inches, call `'FontUnits','inches','FontSize',0.3` in the argument list.

'FontWeight' - Weight of text characters

`'normal'` (default) | `'bold'` | `'light'` | `'demi'`

Weight of text characters, specified as the comma-separated pair consisting of `'FontWeight'` and one of the following strings:

- `'normal'`
- `'bold'`
- `'light'`
- `'demi'`

MATLAB uses the `FontWeight` property to select a font from those available on your particular system. Generally, setting this property to `'bold'` or `'demi'` causes MATLAB to use a bold font.

Example: `'FontWeight','bold'`

'LabelSpacing' - Spacing between labels

144 (default) | scalar

Spacing between labels on each contour line, specified as the comma-separated pair consisting of `'LabelSpacing'` and a scalar. Specify the label spacing in points, where 1 point = $\frac{1}{72}$ inch.

Example: `'LabelSpacing',72`

'Rotation' - Text orientation

0 (default) | scalar

Text orientation, specified as the comma-separated pair consisting of 'Rotation' and a scalar. Specify values of rotation in degrees. Positive values result in counterclockwise rotation.

Example: 'Rotation',45

Output Arguments

text_handles - Handles of text objects

handle

Handles of the text objects that `clabel` creates. The `UserData` properties of the text objects contain the contour values displayed.

If you call `clabel` without the `h` argument, `text_handles` also contains the handles of line objects used to create the '+' symbols.

Examples

Label Contour Plot with Vertical Text and '+' Symbols

Generate a contour plot and obtain the contour matrix, `C`.

```
[x,y,z] = peaks;  
figure  
C = contour(x,y,z);
```

clabel

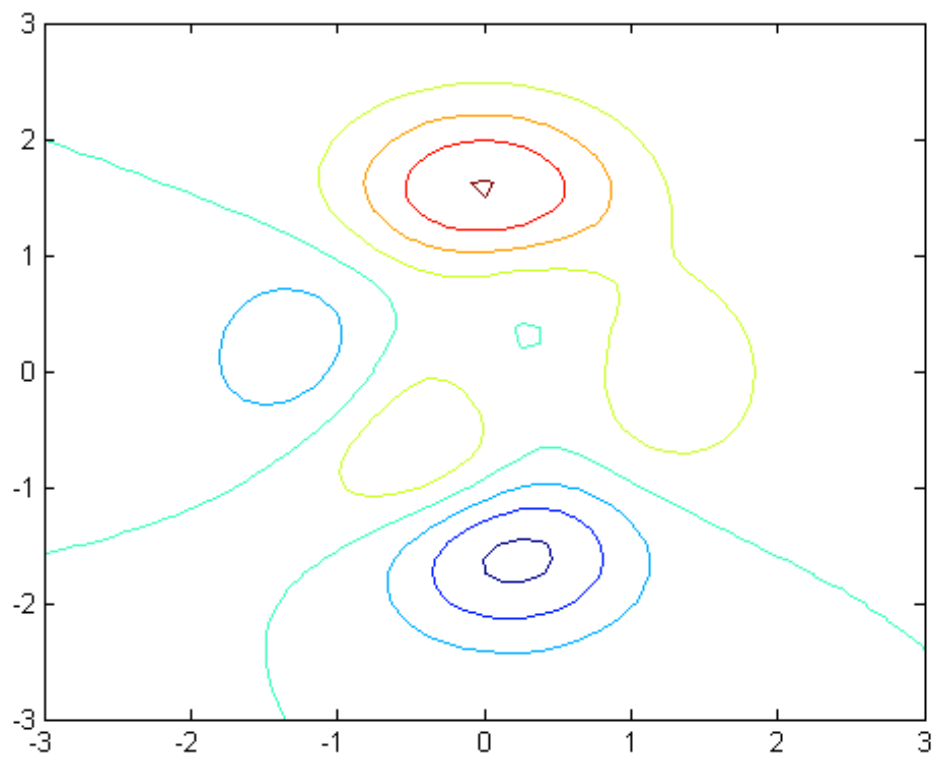

Label the contour plot.

```
clabel(C)
```

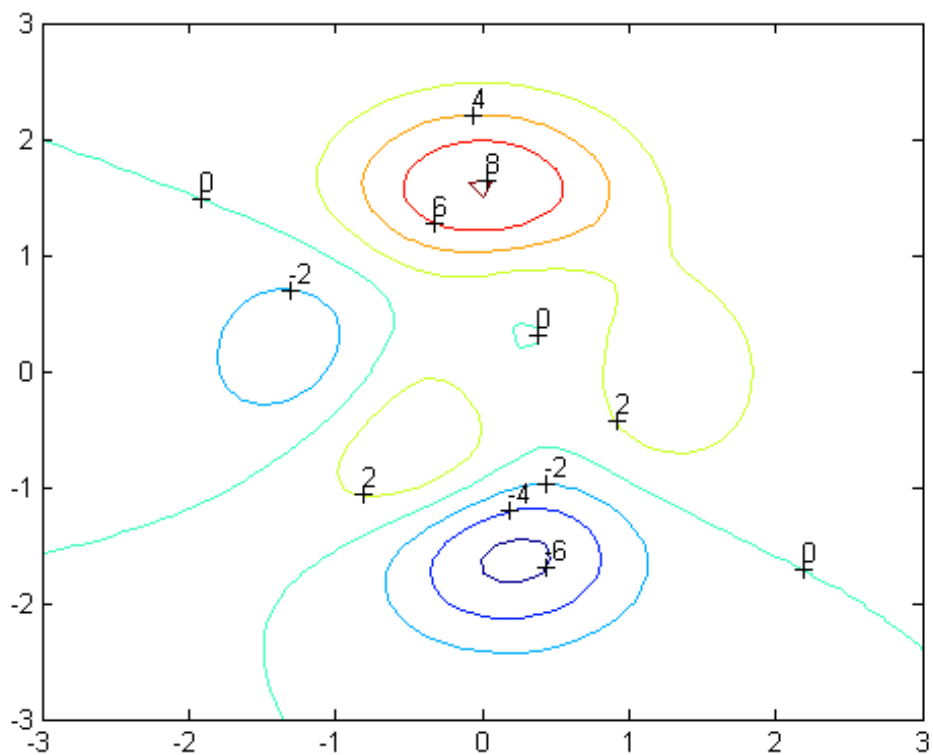

Label Contour Plot with Rotated Text Inserted in Contour Lines

Generate a contour plot and obtain the contour matrix, C , and the handle to the contourgroup object, h .

```
[x,y,z] = peaks;  
figure  
[C,h] = contour(x,y,z);
```

clabel

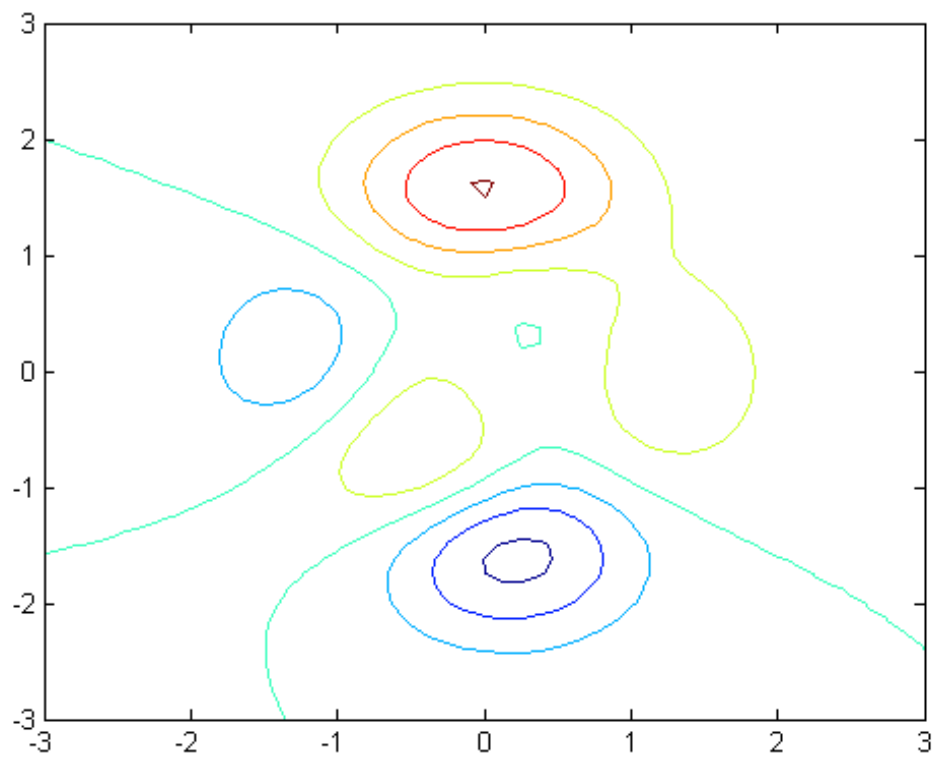

Label the contour plot.

```
clabel(C,h);
```

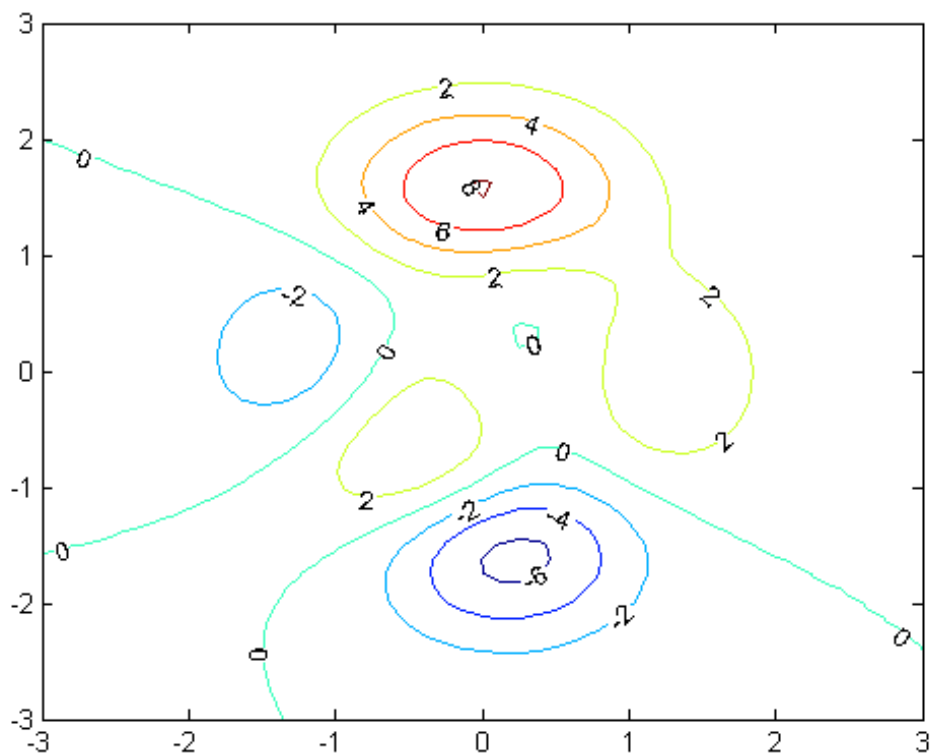

Label Specific Contour Levels

Label only the contours with contour levels 2 or 6.

```
[x,y,z] = peaks;
figure
[C,h] = contour(x,y,z);
v = [2,6];
clabel(C,h,v)
```

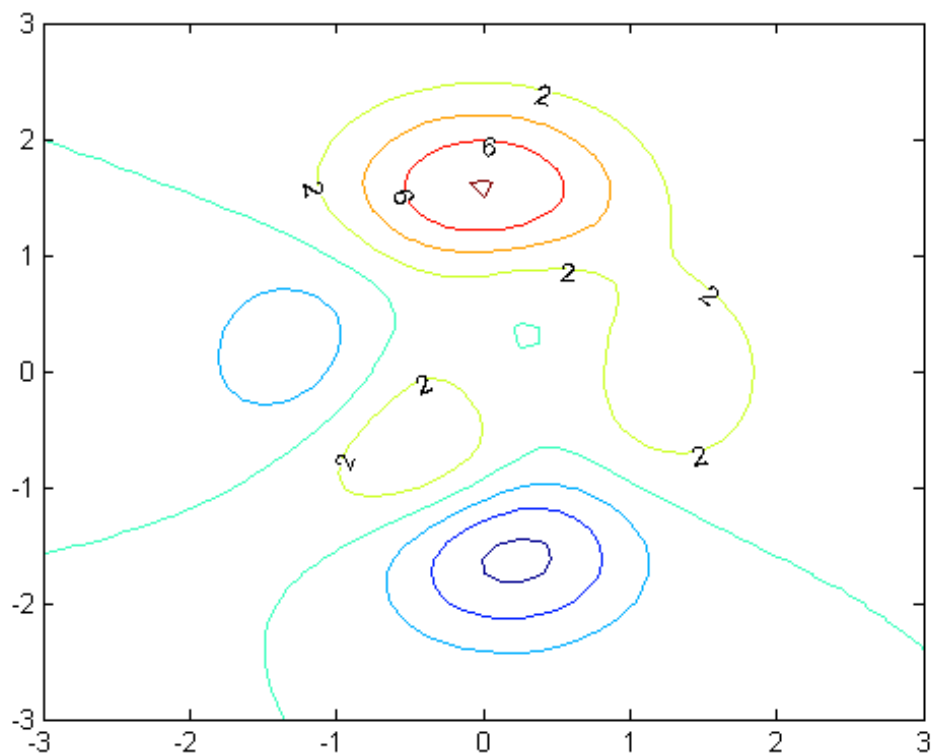

Set Label Spacing

Set the label spacing to 72 points (1 inch).

```
[x,y,z] = peaks;  
figure  
[C,h] = contour(x,y,z);  
clabel(C,h,'LabelSpacing',72)
```

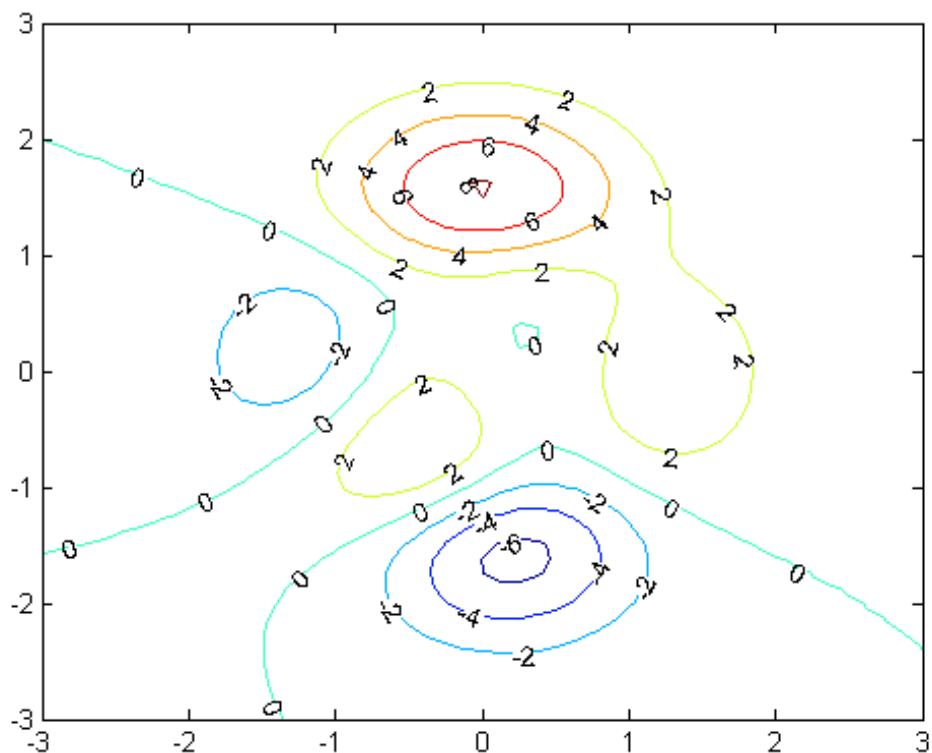

Label Contour Plot and Set Text Properties

Use `Name`, `Value` arguments to set the font size, font color, and text orientation of the labels.

```
[x,y,z] = peaks;  
figure  
[C,h] = contour(x,y,z);  
clabel(C,h,'FontSize',15,'Color','r','Rotation',0)
```

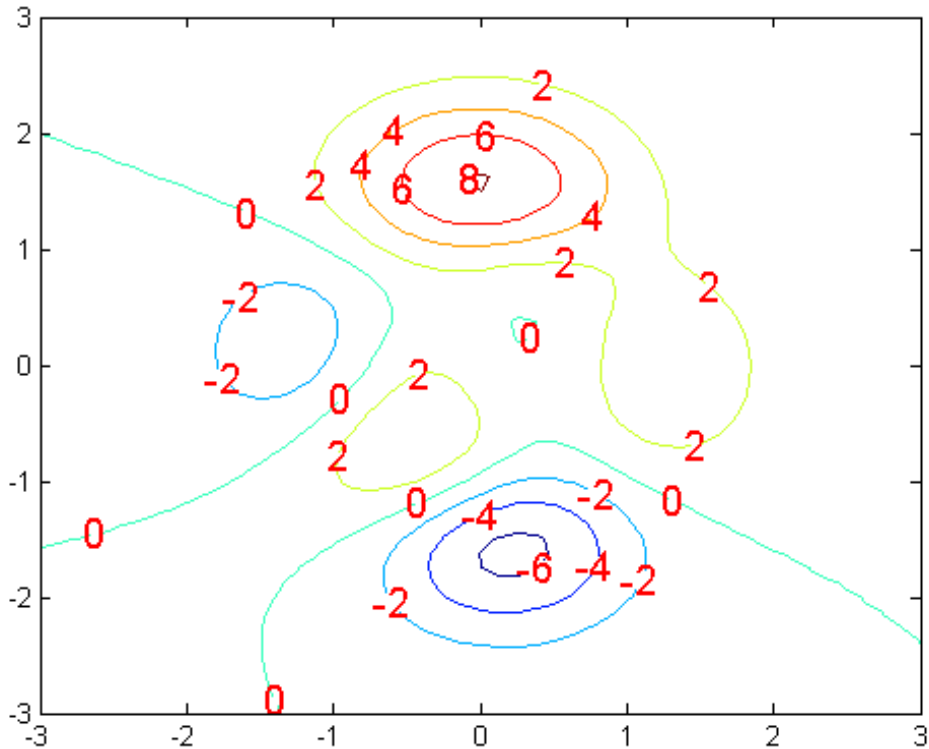

'FontSize',15,'Color','r' adds 15-point red labels to the contour plot. 'Rotation',0 makes the text upright.

Label Contour Plot and Return Object Handles

Label a contour plot and return the handles of the objects created.

```
[x,y,z] = peaks;  
figure  
[C,h] = contour(x,y,z);  
text_handles = clabel(C,h);
```

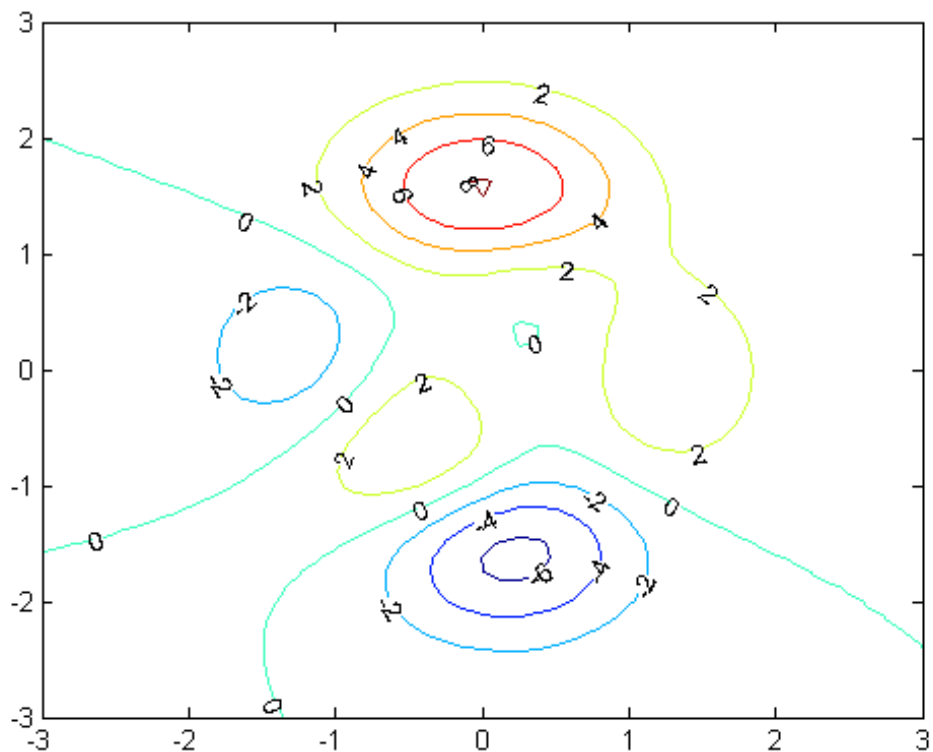



MATLAB® returns an array containing the handles of the text objects created.

Set the color of the labels to blue, using the handle to the text objects.

```
set(text_handles, 'Color', 'blue')
```

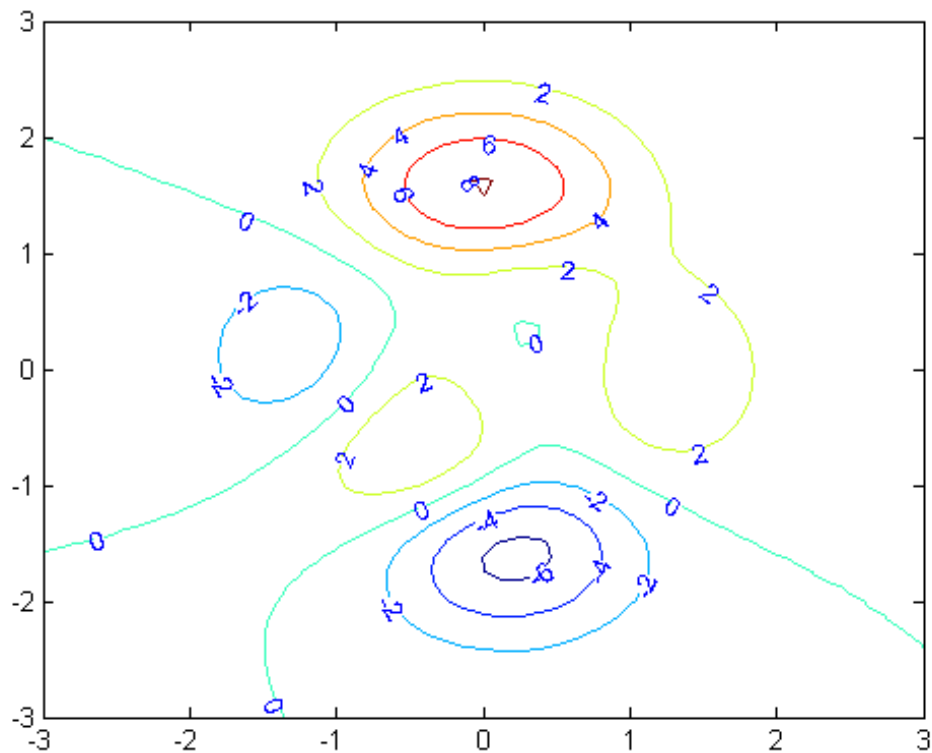
clabel



See Also

[contour](#) | [contourc](#) | [contourf](#) | [contour3](#)

Related Examples

- [“Drawing Text in a Box”](#)

Concepts

[Text Properties](#)

Purpose

Determine class of object

Syntax

```
ClassName = class(object)
obj = class(s, 'class_name')
obj = class(s, 'class_name', parent1, parent2, ...)
obj = class(struct([]), 'class_name', parent1, parent2, ...)
obj_struct = class(struct_array, 'class_name', parent_array)
```

Description

ClassName = `class(object)` returns a string specifying the class of object. See “Fundamental MATLAB Classes” for more information on MATLAB classes.

Note Before MATLAB 7.6 (classes defined without a `classdef` statement), class constructors called the `class` function to create the object. The following `class` function syntaxes apply only within classes defined before Version 7.6.

`obj = class(s, 'class_name')` creates an array of class *class_name* objects using the struct *s* as a pattern to determine the size of *obj*.

`obj = class(s, 'class_name', parent1, parent2, ...)` inherits the methods and fields of the parent objects *parent1*, *parent2*, and so on. The size of the parent objects must match the size of *s* or be a scalar (1-by-1), in which case, MATLAB performs scalar expansion.

`obj = class(struct([]), 'class_name', parent1, parent2, ...)` constructs object containing only fields that it inherits from the parent objects. All parents must have the same, nonzero size, which determines the size of the returned object *obj*.

`obj_struct = class(struct_array, 'class_name', parent_array)` maps every element of the *parent_array* to a corresponding element in the *struct_array* to produce the output array of objects, *obj_struct*.

All arrays must be of the same size. If either the *struct_array* or the *parent_array* is of size 1-by-1, then MATLAB performs scalar expansion to match the array sizes.

class

To create an object array of size 0-by-0, set the size of the `struct_array` and `parent_array` to 0-by-0.

Examples

Return the class of Java object `obj`:

```
import java.lang.*;
obj = String('mystring');
class(obj)
```

```
ans =
```

```
java.lang.String
```

Return class of any MATLAB variable:

```
h = @sin;
class(h)
```

```
ans =
```

```
function_handle
```

See Also

`isa` | `isobject` | `metaclass`

Tutorials

- “Class Syntax Fundamentals”

Purpose Class definition keywords

Syntax

```
classdef classname
    properties
        PropName
    end
    methods
        methodName
    end
    events
        EventName
    end
    enumeration
        EnumName (arg)
    end
end
```

Description `classdef classname` begins the class definition and an `end` keyword terminates the `classdef` block. Only blank lines and comments can precede `classdef`. Enter a class definition in a file having the same name as the class, with a filename extension of `.m`. Class definition files can be in folders on the MATLAB path or in `@` folders whose parent folder is on the MATLAB path. See “Class Files” for more information. See “Classdef Block” and “Class Definition” for more information on classes.

`properties` begins a property definition block, an `end` keyword terminates the `properties` block. Class definitions can contain multiple property definition blocks, each specifying different attribute settings that apply to the properties in that particular block. See “Defining Properties” for more information.

Note Properties cannot have the same name as the class.

classdef

`methods` begins a methods definition block, an `end` keyword terminates the `methods` block. This block contains functions that implement class methods. Class definitions can contain multiple method blocks, each specifying different attribute settings that apply to the methods in that particular block. It is possible to define method functions in separate files. See “How to Use Methods” for more information.

`events` begins an events definition block, an `end` keyword terminates the `events` block. This block contains event names defined by the class. Class definitions can contain multiple event blocks, each specifying different attribute settings that apply to the events in that particular block. See “Events and Listeners — Syntax and Techniques” for more information.

`enumeration` begins an enumeration definition block, an `end` keyword terminates the `enumeration` block. See “Enumerations” for more information.

`properties`, `methods`, `events`, and `enumeration` are also the names of MATLAB functions used to query the respective class members for a given object or class name.

To see the attributes of all class components in a popup window, click this link: [Attribute Tables](#)

Examples

Use these keywords to define classes.

```
classdef (Attributes) class_name
    properties (Attributes)
        PropertyName
    end
    methods (Attributes)
        function obj = methodName(obj, arg2, ...)
            ...
        end
    end
    events (Attributes)
        EventName
end
```

```
enumeration  
    EnumName  
end  
end
```

See Also properties | methods | events

Tutorials • “Class Syntax Fundamentals”

clc

Purpose Clear Command Window

Syntax `clc`

Description `clc` clears all input and output from the Command Window display, giving you a “clean screen.”

After using `clc`, you cannot use the scroll bar to see the history of functions, but you still can use the up arrow key, ↑, to recall statements from the command history.

Examples Use `clc` in a MATLAB code file to always display output in the same starting position on the screen.

See Also `clear` | `clf` | `close` | `home`

Purpose	Remove items from workspace, freeing up system memory
Syntax	<pre>clear clear name1 ... nameN clear -regex expr1 ... exprN clear ItemType</pre>
Description	<p><code>clear</code> removes all variables from the current workspace, releasing them from system memory.</p> <p><code>clear name1 ... nameN</code> removes the variables, scripts, functions, or MEX-functions <code>name1 ... nameN</code> from memory.</p> <ul style="list-style-type: none">• If <code>name</code> is a function name, then <code>clear name</code> reinitializes any persistent variables in the function.• If function name is locked by <code>mlock</code>, then it remains in memory.• If variable name is global, then <code>clear</code> removes it from the current workspace, but it remains in the global workspace. <p><code>clear -regex expr1 ... exprN</code> clears all variables that match any of the regular expressions listed. This option only clears variables.</p> <p><code>clear ItemType</code> clears the types of items indicated by <code>ItemType</code>, such as all, functions, or classes.</p>
Input Arguments	<p>name1 ... nameN - Names of variables, scripts, functions, or MEX-functions to clear</p> <p>string</p> <p>Names of variables, scripts, functions, or MEX-functions to clear, specified as strings.</p> <p>Use a partial path to distinguish between different overloaded versions of a function. For example, <code>clear polynom/display</code> clears only the</p>

clear

display method for polynom objects, leaving any other implementations in memory.

expr1 ... exprN - Regular expressions matching names of variables to clear

string

Regular expressions matching names of variables to clear, specified as strings.

ItemType - Type of items to clear

all | classes | functions | global | import | java | mex | variables

Type of items to clear, specified as one of the following strings. Click the linked strings below for additional information.

Value of ItemType	Items Cleared								
	Variables in scope	Scripts and functions	Class definitions	Persistent variables	Debugger breakpoints	MEX functions	Global variables	Imports	Java classes on the dynamic path
all	✓	✓		✓	✓	✓	✓	From command prompt only	
classes	✓	✓	✓	✓	✓	✓	✓		
functions		✓		✓	✓	✓			
global							✓		
import								✓	
java	✓	✓		✓	✓	✓	✓		✓

Value of ItemType	Items Cleared							
	Variables in scope	Scripts and function definitions	Class definitions	Persistent variables	Debug breakpoints	MEX Global variables	Imports	Java classes on the dynamic path
mex						✓		
variables								

The following applies to clearing types of items.

all:

- `clear all` also removes the import list when issued from the command prompt.

classes:

- `clear classes` issues a warning and does not clear a class of objects if any of those objects still exists after the workspace is cleared. For example, objects can still exist in persistent variables of functions or figure windows.
- `clear classes` does not clear a class if its file is locked using the `mlock` command. No warning is issued in this case.
- Call `clear classes` whenever you change a class definition.

global:

- `clear global` removes all global variables in the base and global workspaces. If called from a function, `clear global` also removes all global variables in the function workspace.
- Use `clear global name1 ... nameN` to clear the global variables with the specified names.
- Use `clear global regexp expr1 ... exprN` to clear all global variables that match any of the regular expressions listed.

clear

import:

- Call `clear import` only from the command prompt. Calling `clear import` in a function returns an error.

java:

- `clear java` issues a warning and does not remove the Java class definition if any Java objects exist outside the workspace (for example, in user data or persistent variables in a locked code file).
- Issue a `clear java` command after modifying any files on the dynamic Java path.

mex:

- `clear mex` does not clear locked MEX functions or functions that are currently in use.

If the name of a variable is a value of `ItemType`, then calling `clear` followed by that name deletes the variable with that name. `clear` does not interpret the name as a keyword in this context. For example, if the workspace contains variables `a`, `all`, `b`, and `ball`, `clear all` removes the variable `all` only.

Tips

- The `clear` function can remove variables that you specify. To remove all but some specified variables, use `clearvars` instead.
- You can clear the handle of a figure or graphics object, but the object itself is not removed. Use `delete` to remove objects. Deleting an object does not delete the variable (if any) used for storing its handle.
- The `clear` function does not clear Simulink® models. Use `bdclose` instead.
- On UNIX systems, `clear` does not affect the amount of memory allocated to the MATLAB process.

Examples

Clear a Single Variable

Define two variables `a` and `b`, and then clear `a`.

```
a = 1;
b = 2;
clear a
whos
```

Name	Size	Bytes	Class	Attributes
b	1x1	8	double	

Only variable `b` remains in the workspace.

Clear Specific Variables by Name

Using regular expressions, clear those variables with names that begin with `Mon`, `Tue`, or `Wed`.

```
clear -regexp ^Mon ^Tue ^Wed;
```

Clear List of Variables

Create a cell array, `varlist`, that contains the names of variables to clear. Then, clear those variables.

```
varlist = {'v1', 'v2', 'time'};
clear(varlist{:})
```

Clear All Compiled Scripts, Functions, and MEX-functions

```
clear functions
```

If a function is locked, it will not be cleared from memory.

See Also

`clc` | `clearvars` | `close` | `delete` | `import` | `inmem` | `load` | `mlock` | `persistent` | `whos` | `workspace`

Concepts

- “Base and Function Workspaces”
- “Strategies for Efficient Use of Memory”
- “Modifying and Reloading Classes”
- “The Java Class Path”
- “Regular Expressions”

clearvars

Purpose Clear variables from memory

Syntax

```
clearvars
clearvars variables
clearvars -except keepVariables
clearvars variables -except keepVariables

clearvars -global ____
```

Description `clearvars` removes all variables from the currently active workspace.

`clearvars variables` removes the variables specified by `variables`. If any of the variables are global, `clearvars` removes these variables from the current workspace only, leaving them accessible to any functions that declare them as global.

`clearvars -except keepVariables` removes all variables, except for those specified by `keepVariables`. Use this syntax to keep specific variables and remove all others.

`clearvars variables -except keepVariables` removes the variables specified by `variables`, and does not remove the variables specified by `keepVariables`. This syntax allows you to use a combination of variable names, wild card characters, or regular expressions to specify variables to remove or keep.

`clearvars -global ____` removes the specified global variables from the workspace, including those made global within functions, using any of the input arguments in the preceding syntaxes. The `-global` flag must be first in the argument list.

Input Arguments

variables - Names of variables to remove

strings

Names of variables to remove, specified as one or more strings in one of the following forms.

Form of Variables Input	Variables to Remove
<i>var1 ... varN</i>	Named variables, specified as individual strings. Use the '*' wildcard to match patterns. For example, <code>clearvars A*</code> clears all variables in the workspace with names that start with A.
<code>-regexp</code> <i>expr1 ... exprN</i>	Variables with names that match the regular expressions, specified as strings. For example, <code>clearvars -regexp ^Mon ^Tues</code> clears only the variables in the workspace with names that begin with Mon or Tues.

keepVariables - Names of variables to keep

strings

Names of variables to keep, specified as one or more strings in one of the following forms.

clearvars

Form of Variables Input	Variables to Keep
<code>var1 ... varN</code>	Named variables, specified as individual strings. Use the '*' wildcard to match patterns. For example, <code>clearvars -except A*</code> clears all variables in the workspace, except those with names that start with A.
<code>-regexp expr1 ... exprN</code>	Variables with names that match the regular expressions, specified as strings. For example, <code>clearvars -except -regexp ^Mon ^Tues</code> clears all the variables in the workspace, except those with names that begin with Mon or Tues.

Examples

Clear Named Variables

Define three variables, a, b, and c. Then, clear a and c.

```
a = 1;  
b = 2;  
c = 3;  
clearvars a c  
whos
```

```
      Name      Size      Bytes  Class  Attributes  
  
      b          1x1           8  double
```

Only variable b remains in the workspace.

Clear All Variables Except Specified

Remove all variables from the workspace except for the variables C and D.

```
clearvars -except C D
```

Clear Variables Using Regular Expressions and Name Variables to Exclude

Clear variables with names that start with `b` and are followed by 3 digits, except for the variable `b106`.

```
clearvars -regexp ^b\d{3}$ -except b106
```

Name Variables to Clear and Preserve Variables Using Regular Expressions

Clear variables with names that start with `a` and do not end with `a`.

```
clearvars a* -except -regexp a$
```

Clear Global Variables Except Specified

Clear all global variables, except those with names that start with `x`.

```
clearvars -global -except x*
```

Clear List of Variables

Clear a list of variables used for intermediate calculations.

Create two variables in the workspace.

```
cashOnHand = 20;  
cost = 12.99;
```

Store a list of the names of all the variables currently in the workspace.

```
initialVars = who;
```

Specify or calculate additional variables, `taxRate` and `tax`.

```
taxRate = 0.0625;  
tax = round(100*cost*taxRate)/100;
```

Update the initial variables, `cost` and `cashOnHand`.

clearvars

```
cost = cost + tax;  
cashOnHand = cashOnHand - cost;
```

Clear all variables except the initial variables, using the function form of `clearvars`. When using the function form of a syntax, enclose input strings in single quotes, and separate them with commas.

```
clearvars('-except',initialVars{:})
```

`clearvars` clears the variables, `initialVars`, `taxRate`, and `tax`.

See Also

`clear` | `exist` | `global` | `persistent` | `save` | `who` | `whos`

Concepts

- “What Is the MATLAB Workspace?”
- “Regular Expressions”
- “Command vs. Function Syntax”

Purpose Remove serial port object from MATLAB workspace

Syntax `clear obj`

Description `clear obj` removes `obj` from the MATLAB workspace, where `obj` is a serial port object or an array of serial port objects.

Tips If `obj` is connected to the device and it is cleared from the workspace, then `obj` remains connected to the device. You can restore `obj` to the workspace with the `instrfind` function. A serial port object connected to the device has a `Status` property value of `open`.

To disconnect `obj` from the device, use the `fclose` function. To remove `obj` from memory, use the `delete` function. You should remove invalid serial port objects from the workspace with `clear`.

Examples This example creates the serial port object `s` on a Windows platform, copies `s` to a new variable `scopy`, and clears `s` from the MATLAB workspace. `s` is then restored to the workspace with `instrfind` and is shown to be identical to `scopy`.

```
s = serial('COM1');
scopy = s;
clear s
s = instrfind;
isequal(scopy,s)
ans =
     1
```

See Also `delete` | `fclose` | `instrfind` | `isvalid` | `Status`

clf

Purpose Clear current figure window

Syntax

```
clf
clf('reset')
clf(fig)
clf(fig, 'reset')
figure_handle = clf(...)
```

Description

clf deletes from the current figure all graphics objects whose handles are not hidden (i.e., their `HandleVisibility` property is set to `on`).

clf('reset') deletes from the current figure all graphics objects regardless of the setting of their `HandleVisibility` property and resets all figure properties except `Position`, `Units`, `PaperPosition`, and `PaperUnits` to their default values.

clf(fig) or clf(fig, 'reset') clears the single figure with handle fig.

figure_handle = clf(...) returns the handle of the figure. This is useful when the figure `IntegerHandle` property is `off` because the noninteger handle becomes invalid when the reset option is used (i.e., `IntegerHandle` is reset to `on`, which is the default).

Tips

The clf command behaves the same way when issued on the command line as it does in callback routines — it does not recognize the `HandleVisibility` setting of callback. This means that when issued from within a callback routine, clf deletes only those objects whose `HandleVisibility` property is set to `on`.

Alternatives

Use **Clear Figure** from the figure window's **Edit** menu to clear the contents of a figure. You can also create a *desktop shortcut* to clear the current figure with one mouse click. See “Create Shortcuts to Rerun Commands”.

See Also cla | clc | hold | reset

Purpose Copy and paste strings to and from system clipboard

Syntax

```
clipboard('copy', data)
str = clipboard('paste')
data = clipboard('pastespecial')
```

Description `clipboard('copy', data)` sets the clipboard contents to *data*. If *data* is not a character array, the clipboard uses `mat2str` to convert *data* to a string.

`str = clipboard('paste')` returns the current contents of the clipboard as a string or, if MATLAB cannot convert the current clipboard contents to a string, as an empty string (' ').

`data = clipboard('pastespecial')` returns the current contents of the clipboard as an array by using `uiimport`.

Definitions The `clipboard` function requires Oracle® Java software.

See Also `load` | `mat2str` | `uiimport`

clock

Purpose Current date and time as date vector

Syntax `c = clock`

Description `c = clock` returns a six-element date vector containing the current date and time in decimal form:

“[year month day hour minute seconds]”

Examples **Round clock Output to Integer Display**

Use `clock` to return the current date and time.

```
format shortg
c = clock
```

```
c =
```

```
2014          1          17          15          46          37.37
```

The sixth element of the date vector output (seconds) is accurate to several digits beyond the decimal point.

Use the `fix` function to round to integer display format.

```
fix(c)
```

```
ans =
```

```
2014          1          17          15          46          37
```

Tips

- To time the duration of an event, use the `timeit` or `tic` and `toc` functions instead of `clock` and `etime`. The `clock` function is based on

the system time, which can be adjusted periodically by the operating system, and thus might not be reliable in time comparison operations.

See Also

`date` | `now` | `tic` | `toc` | `cputime` | `etime` | `fix` | `timeit`

close

Purpose Remove specified figure

Syntax

```
close
close(h)
close name
close all
close all hidden
close all force
status = close(...)
```

Description `close` deletes the current figure or the specified figure(s). It optionally returns the status of the close operation.

`close` deletes the current figure (equivalent to `close(gcf)`).

`close(h)` deletes the figure identified by `h`. If `h` is a vector or matrix, `close` deletes all figures identified by `h`.

`close name` deletes the figure with the specified name.

`close all` deletes all figures whose handles are not hidden.

`close all hidden` deletes all figures including those with hidden handles.

`close all force` deletes all figures, including GUIs for which `CloseRequestFcn` has been altered to not close the window.

`status = close(...)` returns 1 if the specified windows have been deleted and 0 otherwise.

Algorithms The `close` function works by evaluating the specified figure's `CloseRequestFcn` property with the statement

```
eval(get(h, 'CloseRequestFcn'))
```

The default `CloseRequestFcn`, `closereq`, deletes the current figure using `delete(get(0, 'CurrentFigure'))`. If you specify multiple figure handles, `close` executes each figure's `CloseRequestFcn` in turn. If an error that terminates the execution of a `CloseRequestFcn` occurs, the

figure is not deleted. Note that using your computer's window manager (i.e., the **Close** menu item) also calls the figure's `CloseRequestFcn`.

If a figure's handle is hidden (i.e., the figure's `HandleVisibility` property is set to `callback` or `off` and the root `ShowHiddenHandles` property is set to `on`), you must specify the `hidden` option when trying to access a figure using the `all` option.

To delete all figures unconditionally, use the statements

```
set(0, 'ShowHiddenHandles', 'on')
delete(get(0, 'Children'))
```

The figure `CloseRequestFcn` allows you to either delay or abort the closing of a figure once the `close` function has been issued. For example, you can display a dialog box to see if the user really wants to delete the figure or save and clean up before closing.

When coding a `CloseRequestFcn` callback, make sure that it does not call `close`, because this sets up a recursion that results in a MATLAB warning. Instead, the callback should destroy the figure with `delete`. The `delete` function does not execute the figure's `CloseRequestFcn`; it simply deletes the specified figure.

See Also

`delete` | `figure` | `gcf` | `Figure: HandleVisibility` | `Root: ShowHiddenHandles`

Tiff.close

Purpose Close Tiff object

Syntax `tiffobj.close()`

Description `tiffobj.close()` closes a Tiff object.

Examples **Close Tiff Object**

Open a Tiff object and then close it.

```
t = Tiff('example.tif', 'r');  
t.close();
```

References This method corresponds to the `TIFFClose` function in the LibTIFF C API. To use this method, you must be familiar with the TIFF specification and technical notes. View this documentation at [LibTiff - TIFF Library and Utilities](#).

Tutorials

- “Exporting Image Data and Metadata to TIFF Files”
- “Reading Image Data and Metadata from TIFF Files”

Purpose Close Audio/Video Interleaved (AVI) file

Syntax `aviobj = close(aviobj)`

Description `aviobj = close(aviobj)` finishes writing and closes the AVI file associated with `aviobj`, which is an AVI file object created using the `avifile` function.

To close all open AVI files, use the `clear mex` command.

See Also `avifile` | `addframe (avifile)` | `movie2avi`

FTP.close

Purpose Close connection to FTP server

Syntax `close(ftpobj)`

Description `close(ftpobj)` closes the connection to the FTP server.

- Tips**
- If you do not run `close` at the end of your session, the connection either times out automatically or terminates when you exit MATLAB.
 - After calling `close`, calling any other FTP method on the same object automatically reopens the connection.
 - `close` does not return any output to indicate success or failure.

Input Arguments

ftpobj
FTP object created by `ftp`.

Examples Connect to the MathWorks FTP server, and then disconnect:

```
mw=ftp('ftp.mathworks.com');  
close(mw)
```

See Also `ftp`

Purpose	Close file after writing video data
Syntax	<code>close(writerObj)</code>
Description	<code>close(writerObj)</code> closes the file associated with object <code>writerObj</code> . The object remains in the workspace. If you call the <code>open</code> method after closing, <code>open</code> discards any existing contents of the file.
Input Arguments	writerObj VideoWriter object created by the <code>VideoWriter</code> function.
Examples	AVI File from Animation Write a sequence of frames to a compressed AVI file, <code>peaks.avi</code> . Prepare the new file. <pre>writerObj = VideoWriter('peaks.avi'); open(writerObj);</pre> Generate initial data and set axes and figure properties. <pre>Z = peaks; surf(Z); axis tight set(gca, 'nextplot', 'replacechildren'); set(gcf, 'Renderer', 'zbuffer');</pre> Setting the <code>Renderer</code> property to <code>zbuffer</code> or <code>Painters</code> works around limitations of <code>getframe</code> with the OpenGL® renderer on some Windows systems. Create a set of frames and write each frame to the file. <pre>for k = 1:20 surf(sin(2*pi*k/20)*Z,Z) frame = getframe; writeVideo(writerObj,frame);</pre>

VideoWriter.close

```
end  
close(writerObj);
```

See Also

[writeVideo](#) | [VideoWriter](#) | [open](#)

Purpose Default figure close request function

Syntax `closereq`

Description `closereq` deletes the current figure.

See Also | `CloseRequestFcn`

cmopts

Purpose Name of source control system

Syntax cmopts

Description cmopts returns the name of your version control system.

Output Arguments

Value Returned by cmopts	Description	Platform Supported On
clearcase	ClearCase® software from IBM® Rational®	UNIX platforms
customverctrl	Custom interface created using customverctrl function	UNIX platforms
cvs	Concurrent Version System (CVS)	UNIX platforms
none	No source control system selected	
pvcs	PVCS® and ChangeMan® software	UNIX platforms
rcs	Revision Control System (RCS)	UNIX platforms
Any SCC-compliant source control system, for example, Microsoft Visual SourceSafe	Varies	Windows platforms

Alternatives

To view the currently selected source control system, click the **Preferences** button on the **Home** tab, and select **General > Source Control**.

See Also

checkin | checkout | customverctrl | undocheckout | verctrl

How To

- “Source Control Interface on Microsoft Windows”
- “Source Control Interface on UNIX Platforms”

cmpermute

Purpose Rearrange colors in colormap

Syntax `[Y,newmap] = cmpermute(X,map)`
`[Y,newmap] = cmpermute(X,map,index)`

Description `[Y,newmap] = cmpermute(X,map)` randomly reorders the colors in `map` to produce a new colormap, `newmap`. The `cmpermute` function also modifies the values in `X` to maintain correspondence between the indices and the colormap, and returns the result in `Y`. The image `Y` and associated colormap, `newmap`, produce the same image as `X` and `map`.

`[Y,newmap] = cmpermute(X,map,index)` uses an ordering matrix (such as the second output of `sort`) to define the order of colors in the new colormap.

Class Support The input image `X` can be of class `uint8` or `double`. `Y` is returned as an array of the same class as `X`.

Examples Randomly Reorder Colormap and Display Image

Load the `clown` data set to get image `X` and its associated colormap, `map`. Display the image.

```
load clown
figure;
image(X);
colormap(map)
```

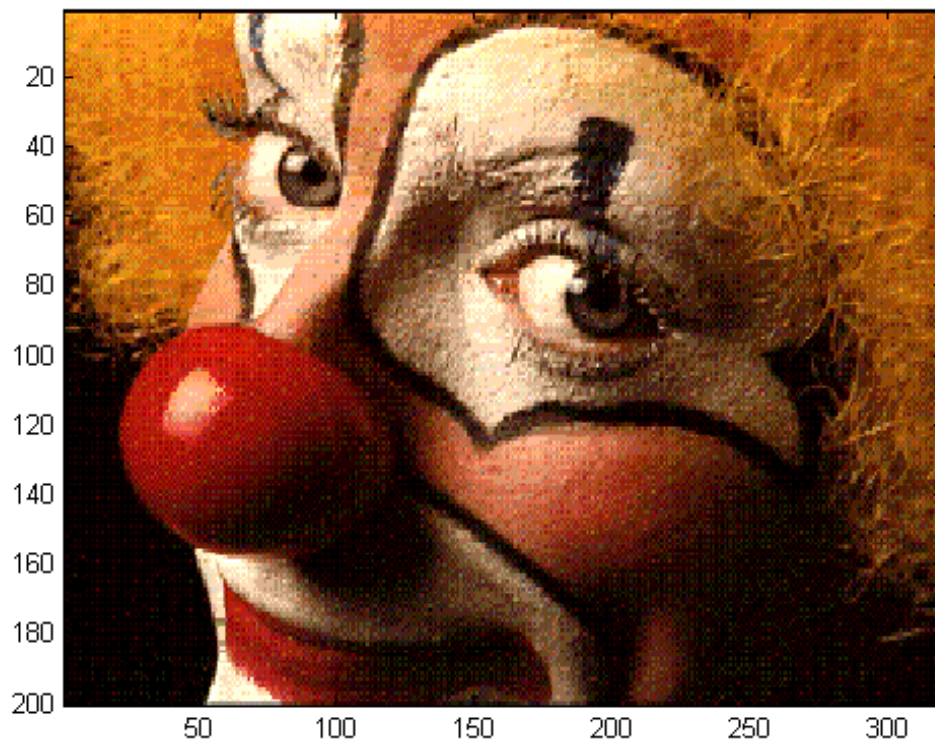

Randomly reorder the colormap to get the new colormap, newmap.
Display image X with the new colormap.

```
[Y, newmap] = cmpermute(X,map);  
colormap(newmap)
```

cmpermute

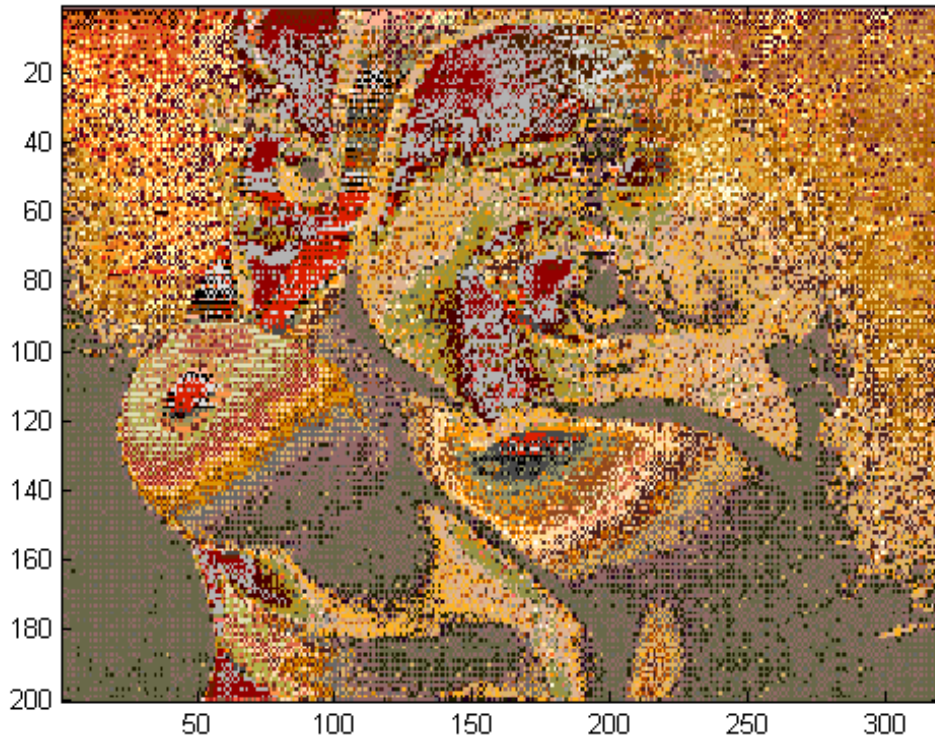

See Also [randperm](#) | [sort](#)

Purpose Eliminate duplicate colors in colormap; convert grayscale or truecolor image to indexed image

Syntax

```
[Y,newmap] = cmunique(X,map)
[Y,newmap] = cmunique(RGB)
[Y,newmap] = cmunique(I)
```

Description [Y,newmap] = cmunique(X,map) returns the indexed image Y and associated colormap, newmap, that produce the same image as (X,map) but with the smallest possible colormap. The cmunique function removes duplicate rows from the colormap and adjusts the indices in the image matrix accordingly.

[Y,newmap] = cmunique(RGB) converts the truecolor image RGB to the indexed image Y and its associated colormap, newmap. The return value newmap is the smallest possible colormap for the image, containing one entry for each unique color in RGB.

Note newmap might be very large, because the number of entries can be as many as the number of pixels in RGB.

[Y,newmap] = cmunique(I) converts the grayscale image I to an indexed image Y and its associated colormap, newmap. The return value, newmap, is the smallest possible colormap for the image, containing one entry for each unique intensity level in I.

Class Support The input image can be of class uint8, uint16, or double. The class of the output image Y is uint8 if the length of newmap is less than or equal to 256. If the length of newmap is greater than 256, Y is of class double.

Examples **Eliminate Duplicate Entries in Colormap**

Use the magic function to define X as a 4-by-4 array that uses every value in the range between 1 and 16.

cmunique

```
X = magic(4);
```

Use the `gray` function to create an eight-entry colormap. Then, concatenate the two eight-entry colormaps to create a colormap with 16 entries, `map`. In `map`, entries 9 through 16 are duplicates of entries 1 through 8.

```
map = [gray(8); gray(8)];  
size(map)
```

```
ans =
```

```
16    3
```

Use `cmunique` to eliminate duplicate entries in the colormap.

```
[Y, newmap] = cmunique(X, map);  
size(newmap)
```

```
ans =
```

```
8    3
```

`cmunique` adjusts the values in the original image `X` so that `Y` and `newmap` produce the same image as `X` and `map`.

```
figure  
image(X)  
colormap(map)  
title('X and map')
```

```
figure  
image(Y)
```

```
colormap(newmap)  
title('Y and newmap')
```

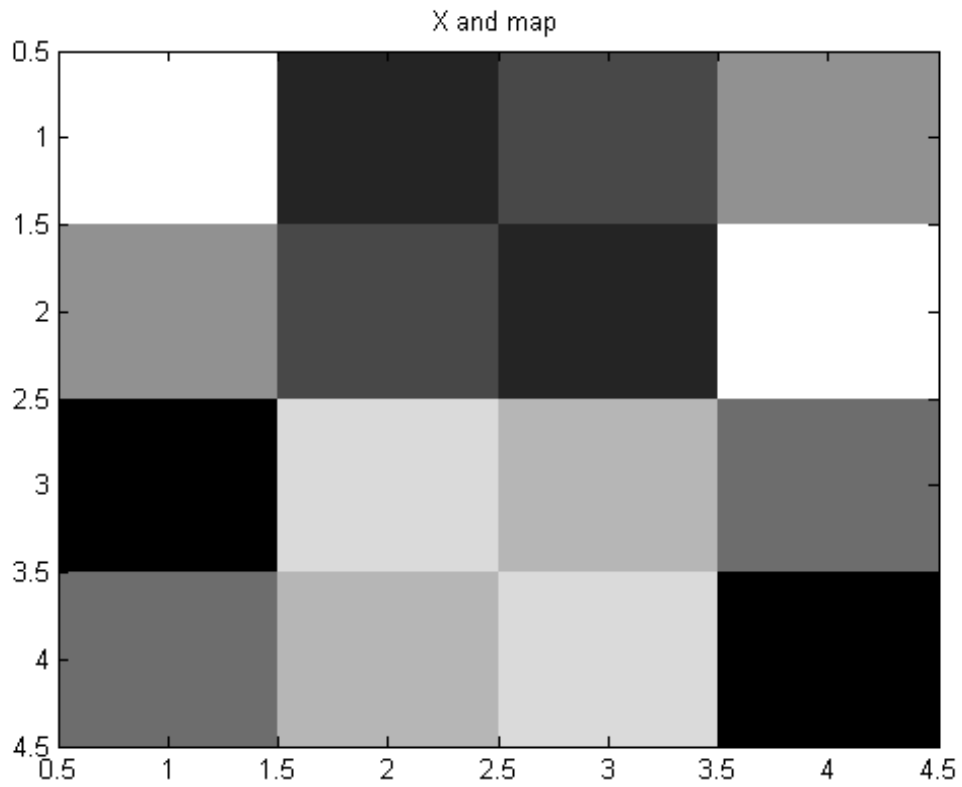

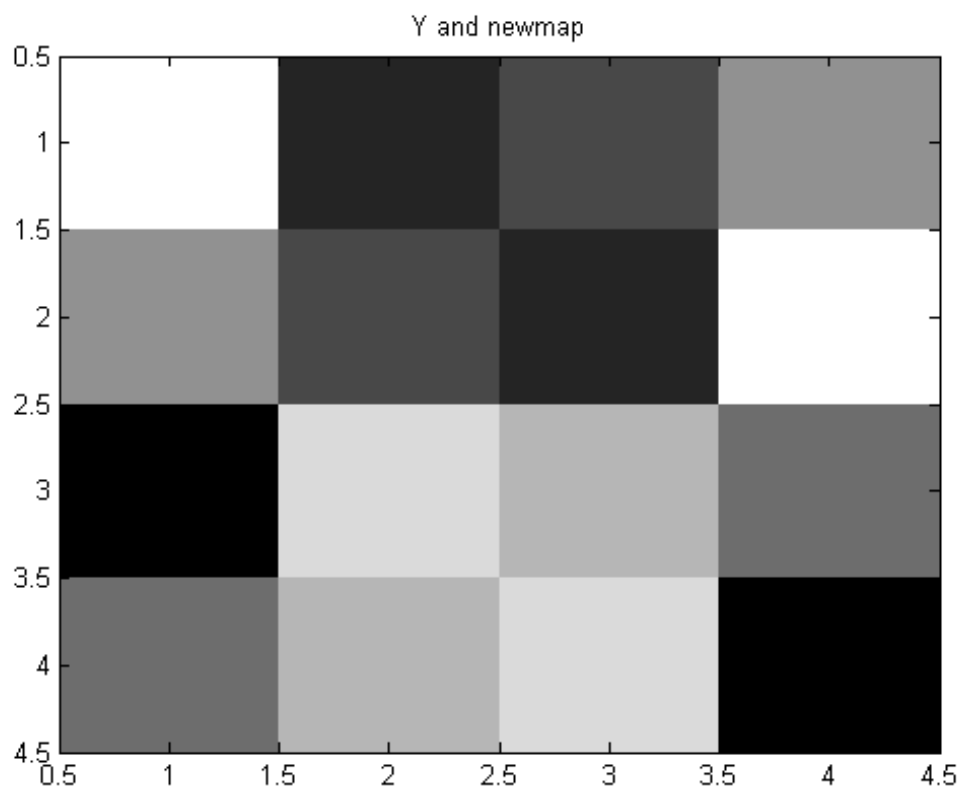

See Also `rgb2ind`

Purpose Column approximate minimum degree permutation

Syntax `p = colamd(S)`

Description `p = colamd(S)` returns the column approximate minimum degree permutation vector for the sparse matrix `S`. For a non-symmetric matrix `S`, `S(:,p)` tends to have sparser LU factors than `S`. The Cholesky factorization of `S(:,p)' * S(:,p)` also tends to be sparser than that of `S'*S`.

`knobs` is a two-element vector. If `S` is `m`-by-`n`, then rows with more than `(knobs(1))*n` entries are ignored. Columns with more than `(knobs(2))*m` entries are removed prior to ordering, and ordered last in the output permutation `p`. If the `knobs` parameter is not present, then `knobs(1) = knobs(2) = spparms('wh_frac')`.

`stats` is an optional vector that provides data about the ordering and the validity of the matrix `S`.

<code>stats(1)</code>	Number of dense or empty rows ignored by <code>colamd</code>
<code>stats(2)</code>	Number of dense or empty columns ignored by <code>colamd</code>
<code>stats(3)</code>	Number of garbage collections performed on the internal data structure used by <code>colamd</code> (roughly of size $2.2*\text{nnz}(S) + 4*m + 7*n$ integers)
<code>stats(4)</code>	0 if the matrix is valid, or 1 if invalid
<code>stats(5)</code>	Rightmost column index that is unsorted or contains duplicate entries, or 0 if no such column exists

<code>stats(6)</code>	Last seen duplicate or out-of-order row index in the column index given by <code>stats(5)</code> , or 0 if no such row index exists
<code>stats(7)</code>	Number of duplicate and out-of-order row indices

Although MATLAB built-in functions generate valid sparse matrices, a user may construct an invalid sparse matrix using the MATLAB C or Fortran APIs and pass it to `colamd`. For this reason, `colamd` verifies that `S` is valid:

- If a row index appears two or more times in the same column, `colamd` ignores the duplicate entries, continues processing, and provides information about the duplicate entries in `stats(4:7)`.
- If row indices in a column are out of order, `colamd` sorts each column of its internal copy of the matrix `S` (but does not repair the input matrix `S`), continues processing, and provides information about the out-of-order entries in `stats(4:7)`.
- If `S` is invalid in any other way, `colamd` cannot continue. It prints an error message, and returns no output arguments (`p` or `stats`).

The ordering is followed by a column elimination tree post-ordering.

Examples

Compare Sparse Matrix and LU Factorization

The Harwell-Boeing collection of sparse matrices and the MATLAB® demos directory include a test matrix `west0479`. It is a matrix of order 479 resulting from a model due to Westerberg of an eight-stage chemical distillation column. The spy plot shows evidence of the eight stages. The `colamd` ordering scrambles this structure.

```
load west0479
A = west0479;
p = colamd(A);

figure();
subplot(1,2,1), spy(A,4), title('A')
```

```
subplot(1,2,2), spy(A(:,p),4), title('A(:,p)')
```

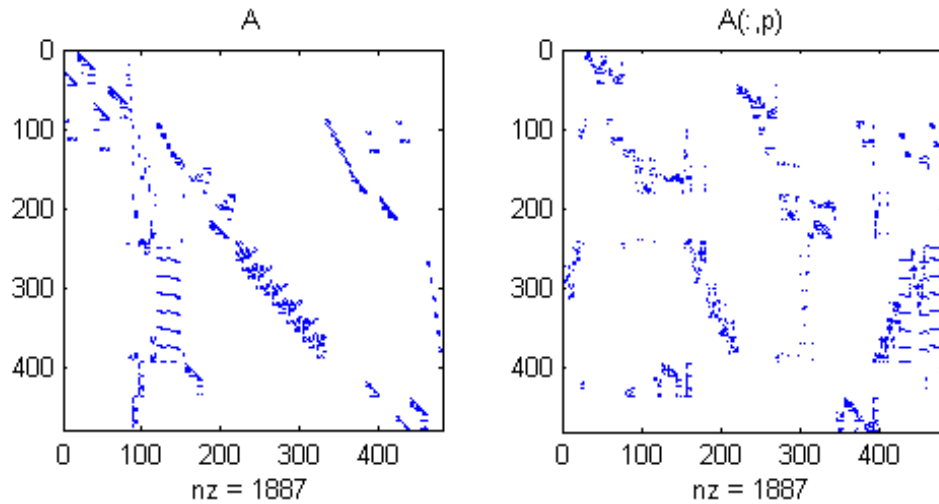

Comparing the spy plot of the LU factorization of the original matrix with that of the reordered matrix shows that minimum degree reduces the time and storage requirements by better than a factor of 2.8. The nonzero counts are 15918 and 5920, respectively.

```
figure();
subplot(1,2,1), spy(lu(A),4), title('lu(A)')
subplot(1,2,2), spy(lu(A(:,p)),4), title('lu(A(:,p))')
```

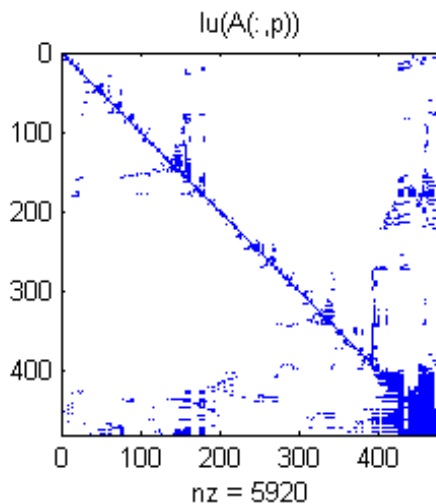
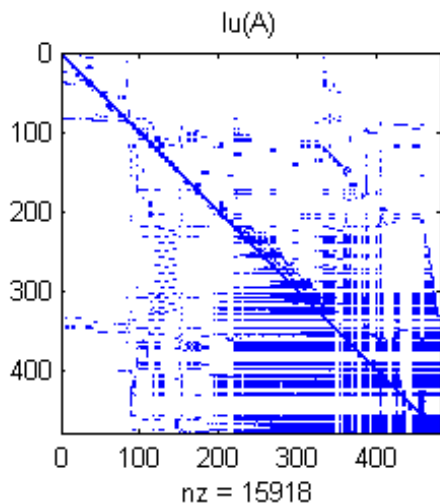

References

[1] The authors of the code for “colamd” are Stefan I. Larimore and Timothy A. Davis (davis@cise.ufl.edu), University of Florida. The algorithm was developed in collaboration with John Gilbert, Xerox PARC, and Esmond Ng, Oak Ridge National Laboratory. Sparse Matrix Algorithms Research at the University of Florida: <http://www.cise.ufl.edu/research/sparse/>

See Also

colperm | spparms | symamd | symrcm

Purpose Colorbar showing color scale

Syntax

```
colorbar
colorbar('off')
colorbar('hide')
colorbar('delete')
colorbar(...,'peer',axes_handle)
colorbar(...,'location')
colorbar(...,'PropertyName',propertyvalue)
cbar_axes = colorbar(...)
colorbar('option')
colorbar(cbar_handle,'option')
```

Description The colorbar function displays the current colormap in the current figure and resizes the current axes to accommodate the colorbar.

colorbar adds a new vertical colorbar on the right side of the current axes. If a colorbar exists in that location, colorbar replaces it with a new one. If a colorbar exists at a nondefault location, it is retained along with the new colorbar.

colorbar('off'), colorbar('hide'), and colorbar('delete') delete all colorbars associated with the current axes.

colorbar(...,'peer',axes_handle) creates a colorbar associated with the axes axes_handle instead of the current axes.

colorbar(...,'location') adds a colorbar in the specified orientation with respect to the axes. If a colorbar exists at the location specified, it is replaced. Any colorbars not occupying the specified location are retained. Possible values for *location* are

North	Inside plot box near top
South	Inside bottom
East	Inside right
West	Inside left

colorbar

NorthOutside	Outside plot box near top
SouthOutside	Outside bottom
EastOutside	Outside right
WestOutside	Outside left

Using one of the `...Outside` values for *location* ensures that the colorbar does not overlap the plot, whereas overlaps can occur when you specify any of the other four values.

`colorbar(..., 'PropertyName', propertyvalue)` specifies property names and values for the axes object used to create the colorbar. See *Axes Properties* for a description of the properties you can set. The *location* property applies only to colorbars and legends, not to axes.

`cbar_axes = colorbar(...)` returns a handle to a new colorbar object, which is a child of the current figure. If a colorbar exists, a new one is still created.

`colorbar('option')` specifies options for colorbar visibility. *'option'* is one of `'off'`, `'hide'` or `'delete'`. All of the options delete the colorbar in the current axes.

`colorbar(cbar_handle, 'option')` specifies options for colorbar visibility. *'option'* is one of `'off'`, `'hide'` or `'delete'`. All of the options delete the colorbar specified by the `cbar_handle`.

You can use `colorbar` with 2-D and 3-D plots.

Tips

To obtain the handle to an existing colorbar, use the command

```
cbar_handle = findobj(figure_handle, 'tag', 'Colorbar')
```

where `figure_handle` is the handle of the figure containing the colorbar you want to modify. If the figure contains more than one colorbar, `cbar_handle` is returned as a vector, and you must choose which of the handles to specify to `colorbar`.

Examples

Display a colorbar beside the axes and use descriptive text strings as y -tick labels. Labels repeat cyclically when the number of y -ticks is greater than the number of labels, and not all labels will appear if there are fewer y -ticks than labels you have specified. Also note that when colorbars are horizontal, their ticks and labels are governed by the `XTick` property rather than the `YTick` property.

```
surf(peaks(30))
colorbar('YTickLabel',...
        {'Freezing','Cold','Cool','Neutral',...
         'Warm','Hot','Burning','Nuclear'})
```

colorbar

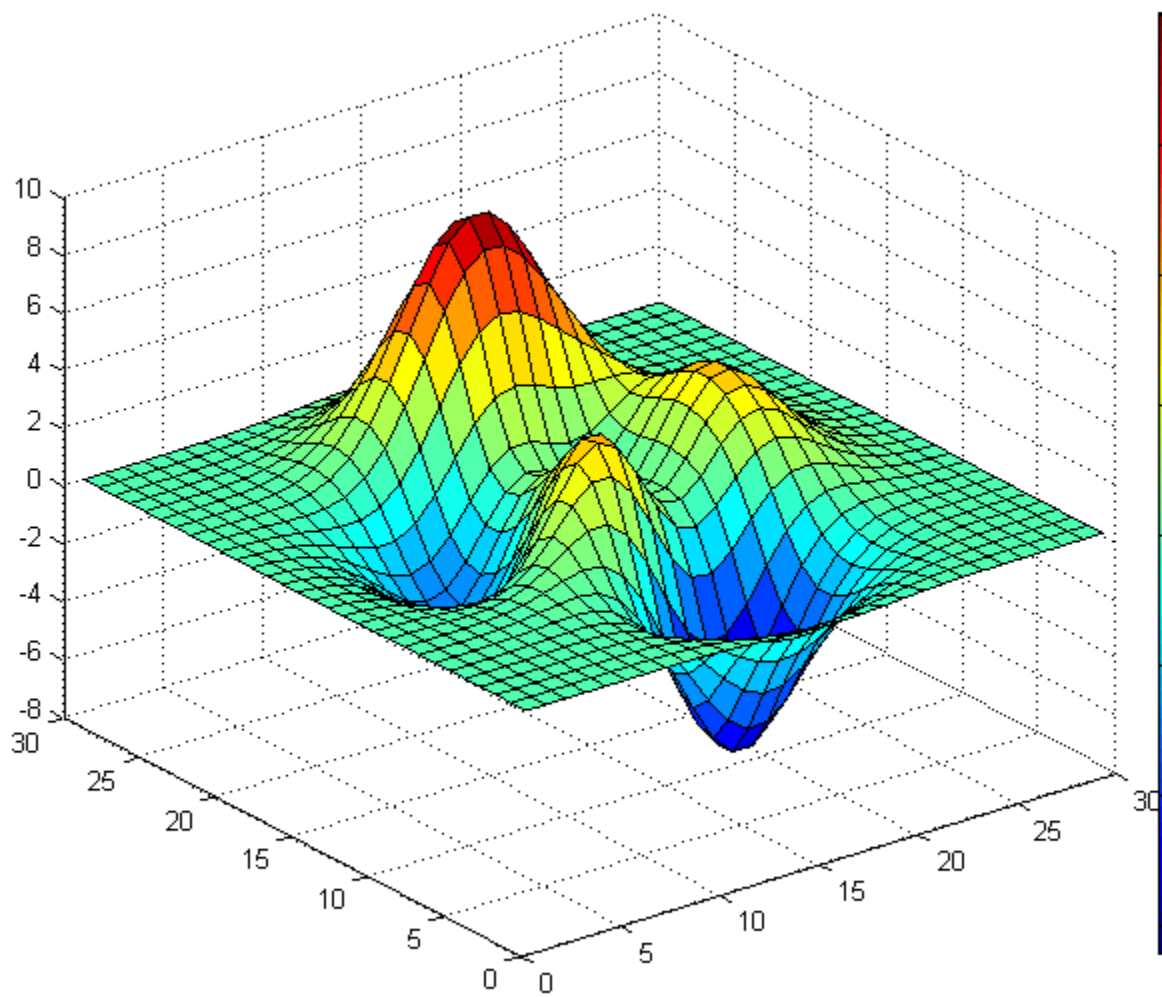

Display a horizontal colorbar beneath the axes of a filled contour plot:

```
contourf(peaks(60))  
colormap cool  
colorbar('location','southoutside')
```

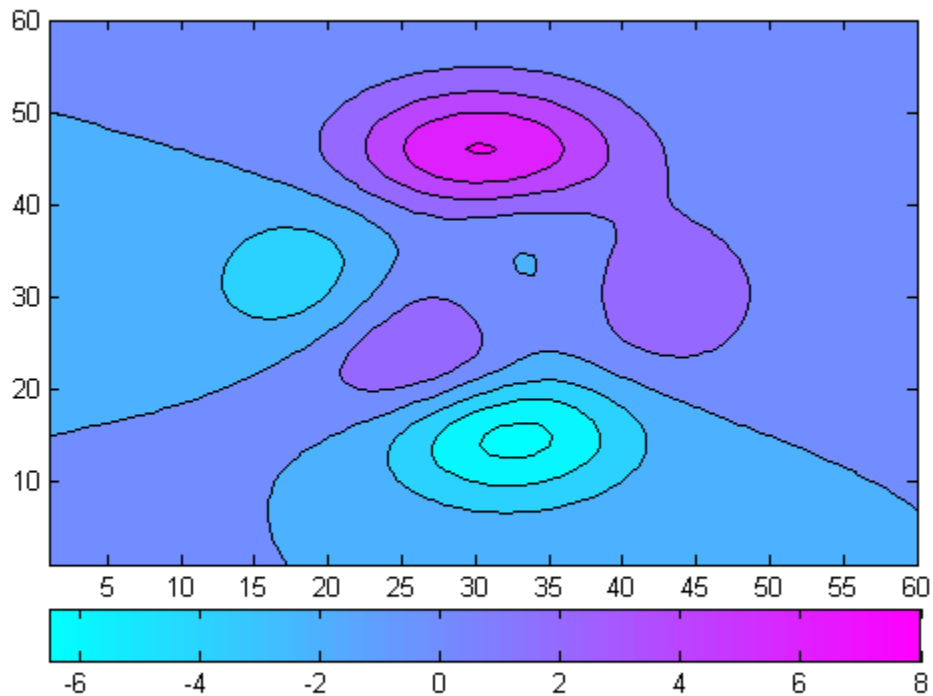

Alternatives

Add a colorbar to a plot with the colorbar tool  on the figure toolbar, or use **Insert > Colorbar** from the figure menu. Use the Property Editor to modify the position, font and other properties of a legend.

colorbar

See Also

`colormap`

Purpose	Set default property values to display different color schemes
Syntax	<pre>colordef white colordef black colordef none colordef(fig,color_option) h = colordef('new',color_option)</pre>
Description	<p>colordef enables you to select either a white or black background for graphics display. It sets axis lines and labels so that they contrast with the background color.</p> <p>colordef white sets the axis background color to white, the axis lines and labels to black, and the figure background color to light gray.</p> <p>colordef black sets the axis background color to black, the axis lines and labels to white, and the figure background color to dark gray.</p> <p>colordef none sets the figure coloring to that used by MATLAB Version 4. The most noticeable difference is that the axis background is set to 'none', making the axis background and figure background colors the same. The figure background color is set to black.</p> <p>colordef(fig,color_option) sets the color scheme of the figure identified by the handle fig to one of the color options 'white', 'black', or 'none'. When you use this syntax to apply colordef to an existing figure, the figure must have no graphic content. If it does, you should first clear it (via clf) before using this form of the command.</p> <p>h = colordef('new',color_option) returns the handle to a new figure created with the specified color options (i.e., 'white', 'black', or 'none'). This form of the command is useful for creating GUIs when you may want to control the default environment. The figure is created with 'visible','off' to prevent flashing.</p>
Tips	colordef affects only subsequently drawn figures, not those currently on the display. This is because colordef works by setting default property values (on the root or figure level). You can list the currently set default values on the root level with the statement

colordef

```
get(0, 'Default')
```

You can remove all default values using the `reset` command:

```
reset(0)
```

See the `get` and `reset` references pages for more information.

See Also

`whitebg` | `clf`

Purpose Set and get current colormap

Syntax

```
colormap(map)
colormap('default')
cmap = colormap
colormap(ax, ...)
```

Description A colormap is an m -by-3 matrix of real numbers between 0.0 and 1.0. Each row is an RGB vector that defines one color. The k th row of the colormap defines the k th color, where $\text{map}(k, :) = [r(k) \ g(k) \ b(k)]$ specifies the intensity of red, green, and blue.

`colormap(map)` sets the colormap to the matrix `map`. If any values in `map` are outside the interval `[0 1]`, you receive the error `Colormap must have values in [0,1]`.

`colormap('default')` sets the current colormap to the default colormap.

`cmap = colormap` retrieves the current colormap. The values returned are in the interval `[0 1]`.

`colormap(ax, ...)` uses the figure corresponding to axes `ax` instead of the current figure.

Specifying Colormaps

Files in the `color` folder generate a number of colormaps. Each file accepts the colormap size as an argument. For example,

```
colormap(hsv(128))
```

creates an `hsv` colormap with 128 colors. If you do not specify a size, a colormap the same size as the current colormap is created.

Supported Colormaps

The built-in MATLAB colormaps are illustrated and described below. In addition to specifying built-in colormaps programmatically, you can use the **Colormap** menu in the **Figure Properties** pane of the Plot Tools GUI to select one interactively.

colormap

The named built-in colormaps are the following:



- autumn varies smoothly from red, through orange, to yellow.
- bone is a grayscale colormap with a higher value for the blue component. This colormap is useful for adding an “electronic” look to grayscale images.
- colorcube contains as many regularly spaced colors in RGB color space as possible, while attempting to provide more steps of gray, pure red, pure green, and pure blue.
- cool consists of colors that are shades of cyan and magenta. It varies smoothly from cyan to magenta.
- copper varies smoothly from black to bright copper.
- flag consists of the colors red, white, blue, and black. This colormap completely changes color with each index increment.
- gray returns a linear grayscale colormap.

- `hot` varies smoothly from black through shades of red, orange, and yellow, to white.
- `hsv` varies the hue component of the hue-saturation-value color model. The colors begin with red, pass through yellow, green, cyan, blue, magenta, and return to red. The colormap is particularly appropriate for displaying periodic functions. `hsv(m)` is the same as `hsv2rgb([h ones(m,2)])` where `h` is the linear ramp, $h = (0:m-1)/m$.
- `jet` ranges from blue to red, and passes through the colors cyan, yellow, and orange. It is a variation of the `hsv` colormap. The `jet` colormap is associated with an astrophysical fluid jet simulation from the National Center for Supercomputer Applications. See “Examples” on page 1-1045.
- `lines` produces a colormap of colors specified by the axes `ColorOrder` property and a shade of gray.
- `pink` contains pastel shades of pink. The pink colormap provides sepia tone colorization of grayscale photographs.
- `prism` repeats the six colors red, orange, yellow, green, blue, and violet.
- `spring` consists of colors that are shades of magenta and yellow.
- `summer` consists of colors that are shades of green and yellow.
- `white` is an all white monochrome colormap.
- `winter` consists of colors that are shades of blue and green.

Examples

Use Summer Colormap

Create a surface plot of the peaks function.

```
figure;  
surf(peaks);
```

colormap

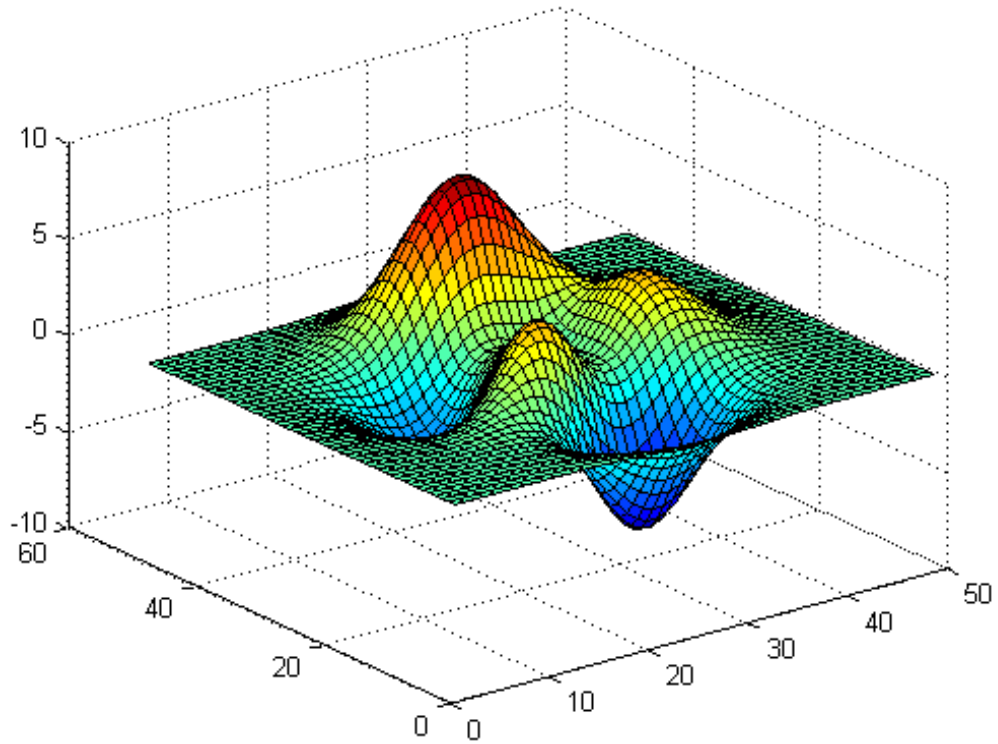

Change the colormap to the summer colormap.

```
colormap(summer)
```

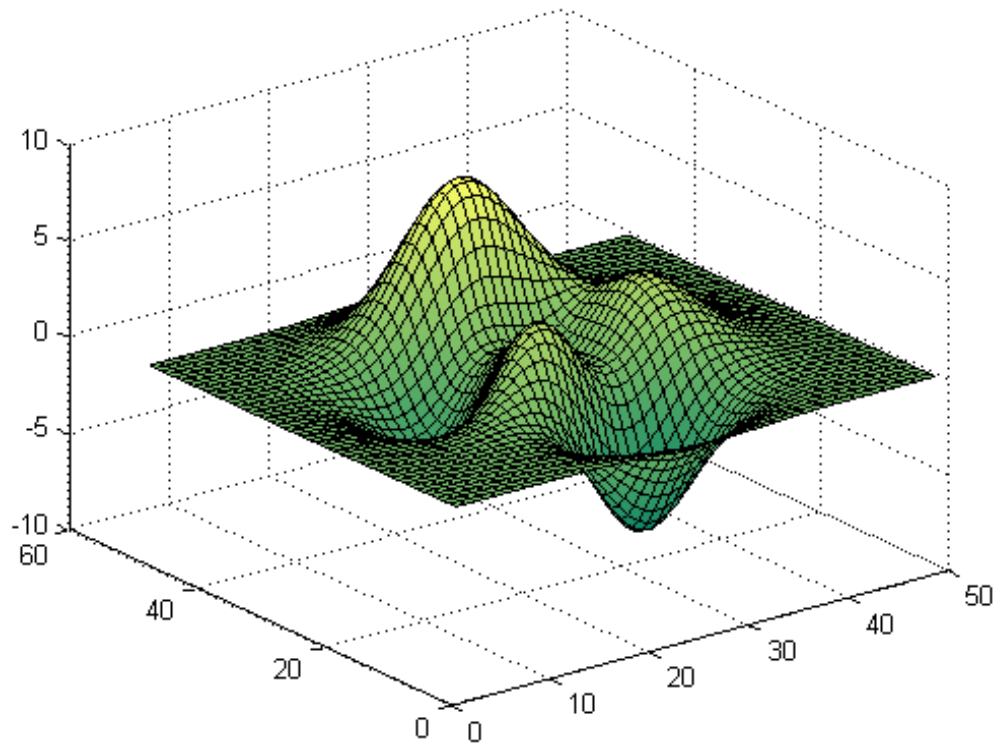



Use Bone Colormap

Load the spine data set to get array `X`. Use the `image` function to display the data in `X`.

```
load spine  
image(X)
```

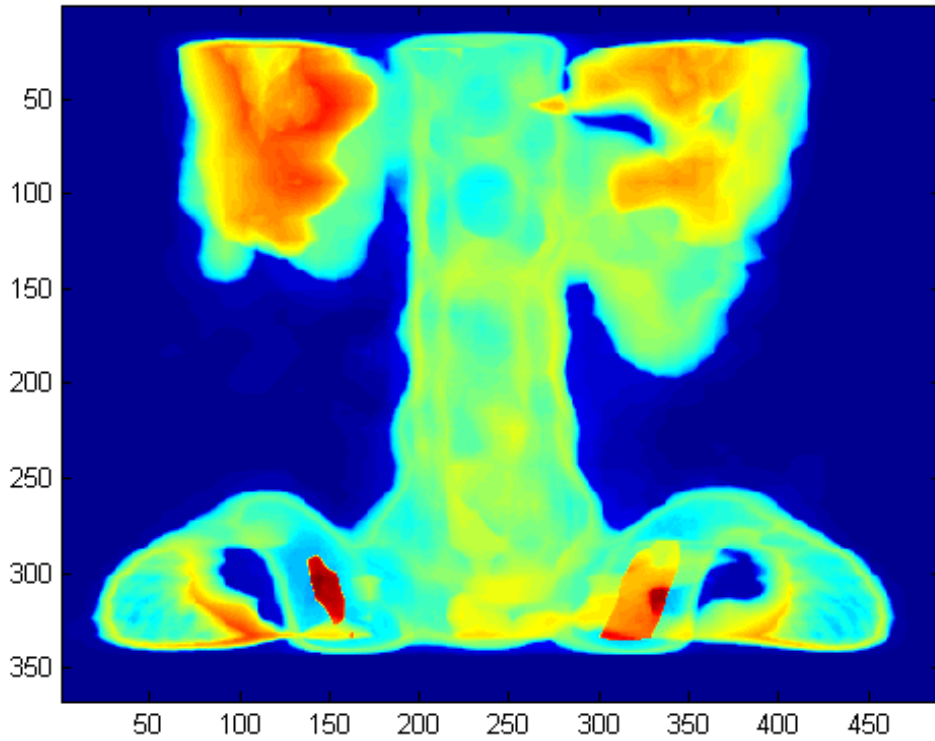
colormap



Change the colormap to the bone colormap.

```
colormap(bone)
```

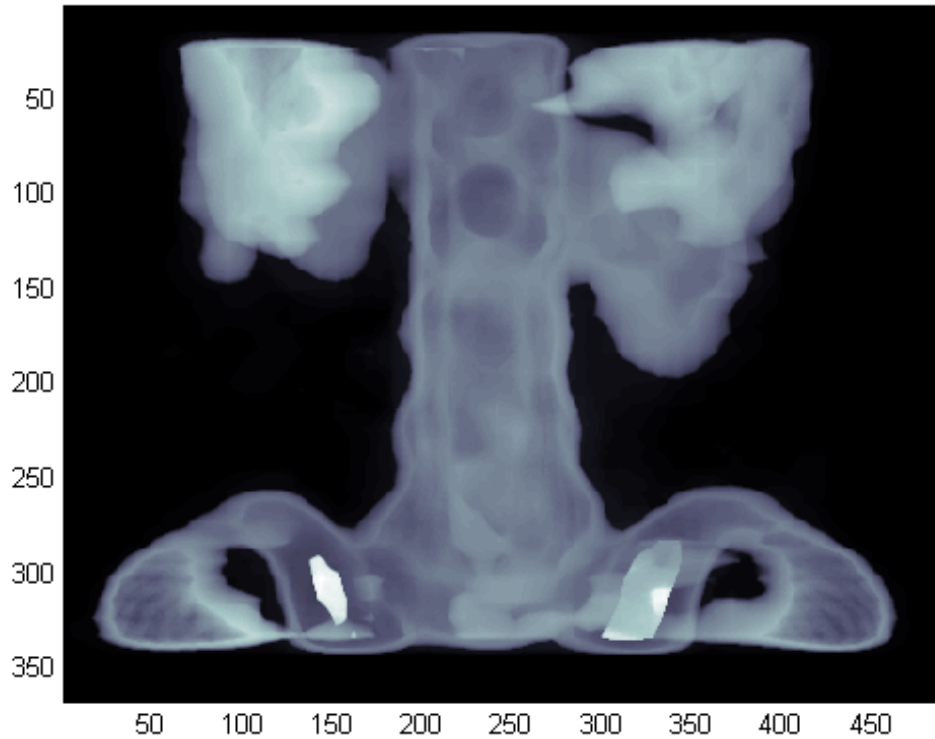

Algorithms

Each figure has its own `colormap` property. `colormap` is a function that sets and gets this property.

Alternatives

Select a built-in colormap with the Property Editor. To modify the current colormap, use the Colormap Editor, accessible from **Edit > Colormap** on the figure menu.

colormap

See Also

[brighten](#) | [caxis](#) | [colorbar](#) | [colormapeditor](#) | [contrast](#) | [hsv2rgb](#)
| [pcolor](#) | [rgbplot](#) | [rgb2hsv](#) | [Colormap](#)

How To

- “Coloring Mesh and Surface Plots”

Purpose Open colormap editor

Syntax colormapeditor

Description colormapeditor displays the current figure's colormap as a strip of rectangular cells in the colormap editor. Node pointers are colored cells below the colormap strip that indicate points in the colormap where the rate of the variation of R, G, and B values changes. You can also work in the HSV colorspace by setting the **Interpolating Colorspace** selector to HSV.

You can also start the colormap editor by selecting **Colormap** from the **Edit** menu.

Node Pointer Operations

You can select and move node pointers to change a range of colors in the colormap. The color of a node pointer remains constant as you move it, but the colormap changes by linearly interpolating the RGB values between nodes.

Change the color at a node by double-clicking the node pointer. A color picker box appears, from which you can select a new color. After you select a new color at a node, the colors between nodes are reinterpolated.

You can select a different color map using the **Standard Colormaps** submenu of the GUI **Tools** menu. The Plotting Tools Property Editor has a dropdown menu that also lets you select from standard colormaps, but does not help you to modify a colormap.

Operation	How to Perform
Select a built-in colormap	Tools > Standard Colormaps
Add a node	Click below the corresponding cell in the colormap strip.
Select a node	Left-click the node.

Operation	How to Perform
Select multiple nodes	Adjacent: left-click first node, Shift+click the last node. Nonadjacent: left-click first node, Ctrl+click subsequent nodes.
Move a node	Select and drag with the mouse or select and use the left and right arrow keys.
Move multiple nodes	Select multiple nodes and use the left and right arrow keys to move nodes as a group. Movement stops when one of the selected nodes hits an unselected node or an end node.
Delete a node	Select the node and then press the Delete key, or select Delete from the Edit menu, or type Ctrl+x .
Delete multiple nodes	Select the nodes and then press the Delete key, or select Delete from the Edit menu, or type Ctrl+x .
Display color picker for a node	Double-click the node pointer.

Current Color Info

When you put the mouse over a color cell or node pointer, the colormap editor displays the following information about that colormap element:

- The element's index in the colormap
- The value from the graphics object color data that is mapped to the node's color (i.e., data from the `CData` property of any image, patch, or surface objects in the figure)
- The color's RGB and HSV color value

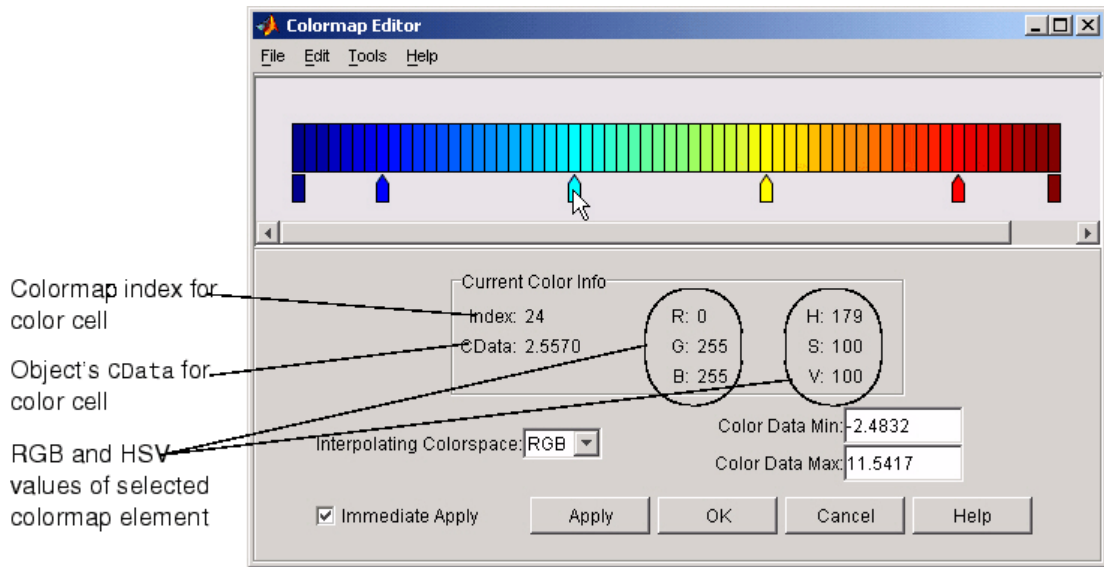

Interpolating Colorspace

The colorspace determines what values are used to calculate the colors of cells between nodes. For example, in the RGB colorspace, internode colors are calculated by linearly interpolating the red, green, and blue intensity values from one node to the next. Switching to the HSV colorspace causes the colormap editor to recalculate the colors between nodes using the hue, saturation, and value components of the color definition.

Note that when you switch from one colorspace to another, the color editor preserves the number, color, and location of the node pointers, which can cause the colormap to change.

Interpolating in HSV. Since hue is conceptually mapped about a color circle, the interpolation between hue values can be ambiguous. To minimize this ambiguity, the interpolation uses the shortest distance around the circle. For example, interpolating between two nodes, one with hue of 2 (slightly orange red) and another with a hue of 356 (slightly magenta red), does not result in hues 3,4,5...353,354,355 (orange/red-yellow-green-cyan-blue-magenta/red). Taking the shortest distance around the circle gives 357,358,1,2 (orange/red-red-magenta/red).

Color Data Min and Max

The **Color Data Min** and **Color Data Max** text fields enable you to specify values for the axes **CLim** property. These values change the mapping of object color data (the **CData** property of images, patches, and surfaces) to the colormap. See “Axes Color Limits — the **CLim** Property” for discussion and examples of how to use this property.

Examples

This example modifies a default MATLAB colormap so that ranges of data values are displayed in specific ranges of color. The graph is a slice plane illustrating a cross section of fluid flow through a jet nozzle. See the [slice](#) reference page for more information on this type of graph.

Example Objectives

The objectives are as follows:

- Regions of flow from left to right (positive data) are mapped to colors from yellow through orange to dark red. Yellow is slowest and dark red is the fastest moving fluid.
- Regions that have a speed close to zero are colored green.
- Regions where the fluid is actually moving right to left (negative data) are shades of blue (darker blue is faster).

The following picture shows the desired coloring of the slice plane. The colorbar shows the data to color mapping.

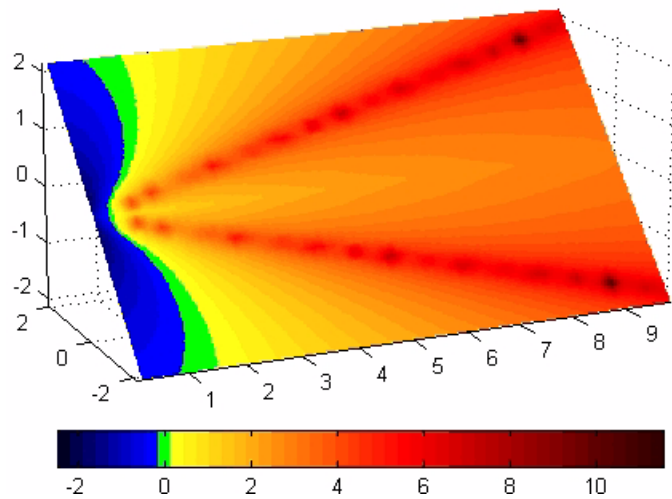

Running the Example

Note If you are viewing this documentation in the MATLAB help browser, you can display the graph used in this example by running this file from the MATLAB editor (select **Run** from the **Debug** menu).

Initially, the default colormap (`jet`) colored the slice plane, as illustrated in the following picture. Note that this example uses a colormap that is 48 elements to display wider bands of color (the default is 64 elements).

colormapeditor

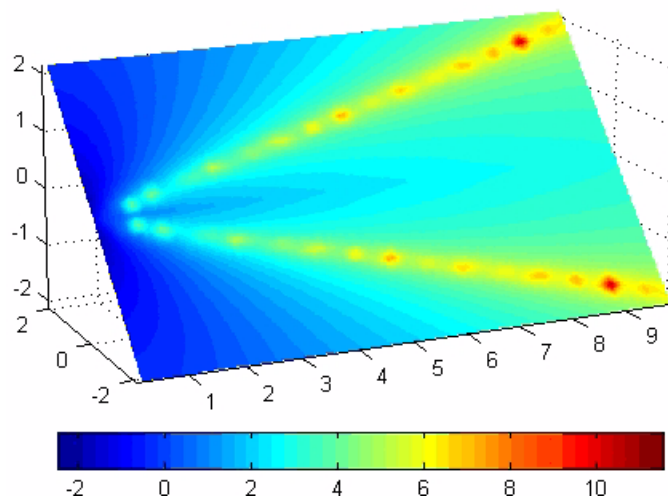

- 1 Start the colormap editor using the `colormapeditor` command. The color map editor displays the current figure's colormap, as shown in the following picture.

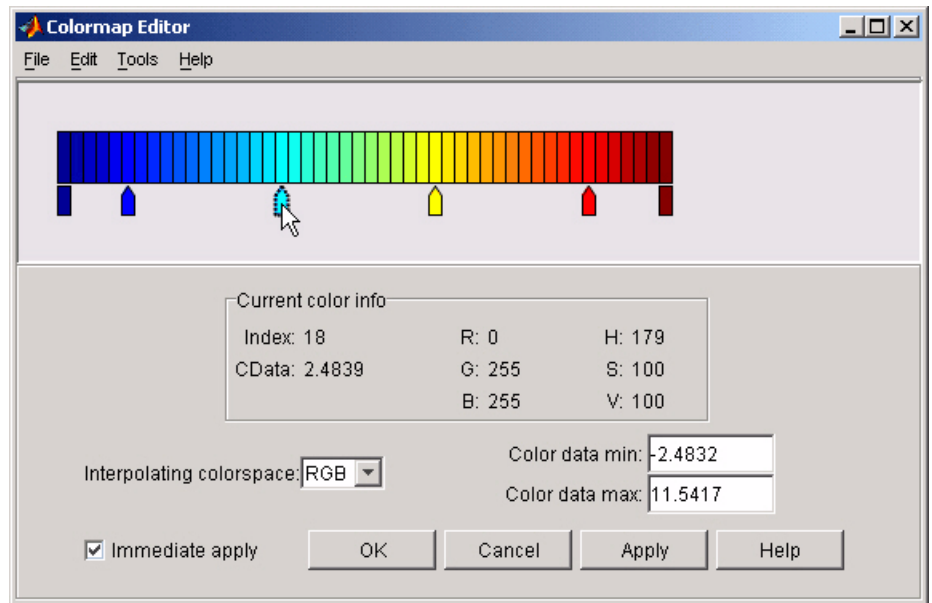

- 2 Since we want the regions of left-to-right flow (positive speed) to range from yellow to dark red, we can delete the cyan node pointer. To do this, first select it by clicking with the left mouse button and press **Delete**. The colormap now looks like this.

colormapeditor

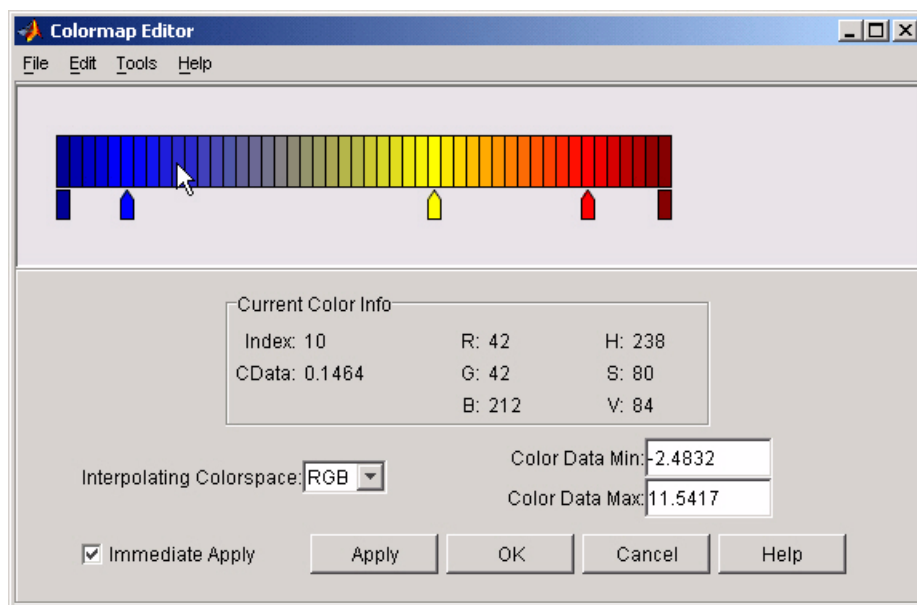

The **Immediate Apply** box is checked, so the graph displays the results of the changes made to the colormap.

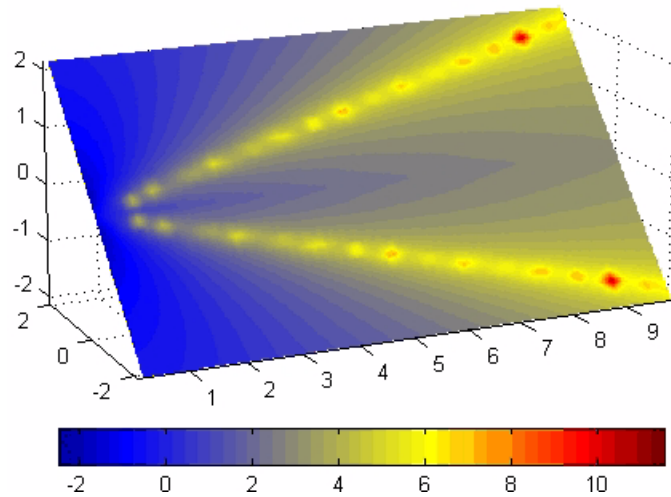

- 3** We want the fluid speed values around zero to stand out, so we need to find the color cell where the negative-to-positive transition occurs. Dragging the cursor over the color strip enables you to read the data values in the **Current Color Info** panel.

In this case, cell 10 is the first positive value, so we click below that cell and create a node pointer. Double-clicking the node pointer displays the color picker. Set the color of this node to green.

colormapeditor

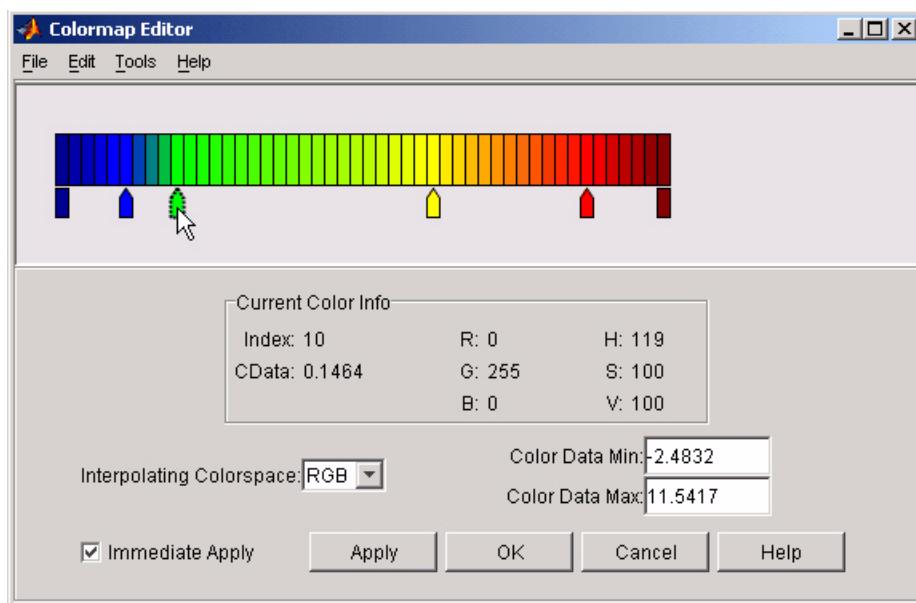

The graph continues to update to the modified colormap.

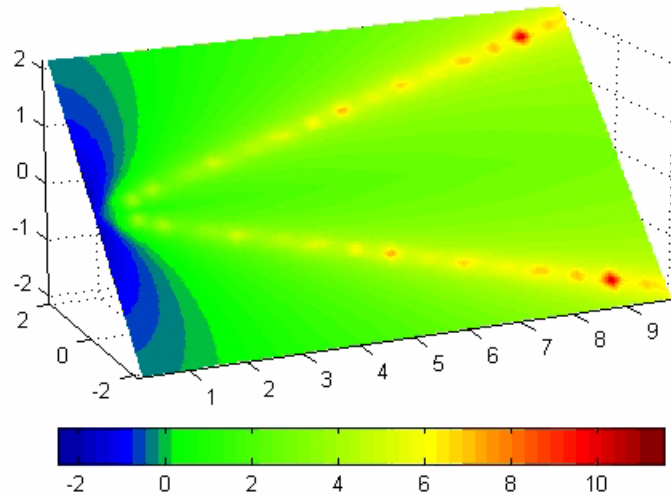

- 4 In the current state, the colormap colors are interpolated from the green node to the yellowish node about 20 cells away. We actually want only the single cell that is centered around zero to be colored green. To limit the color green to one cell, move the blue and yellow node pointers next to the green pointer.

colormapeditor

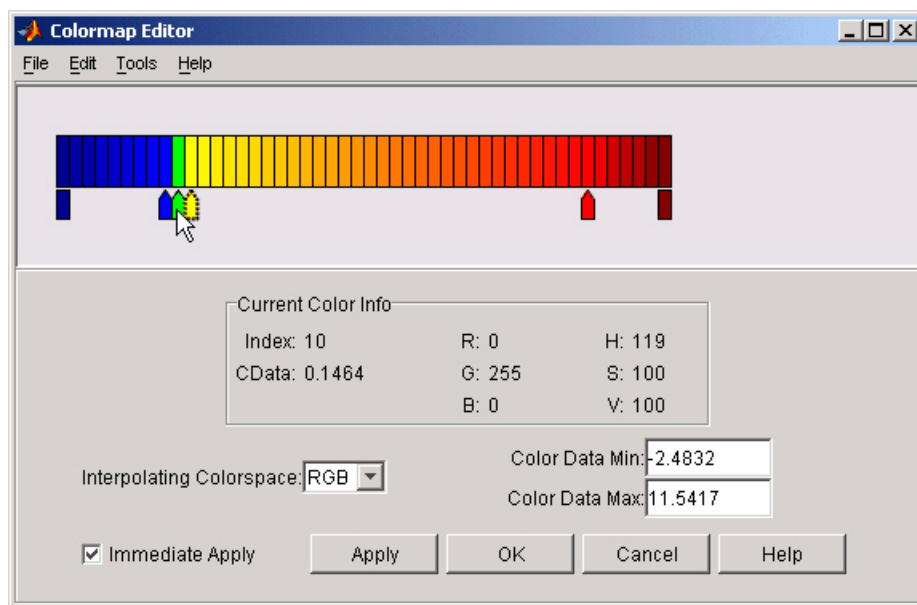

- 5 Before making further adjustments to the colormap, we need to move the green cell so that it is centered around zero. Use the colorbar to locate the green cell.

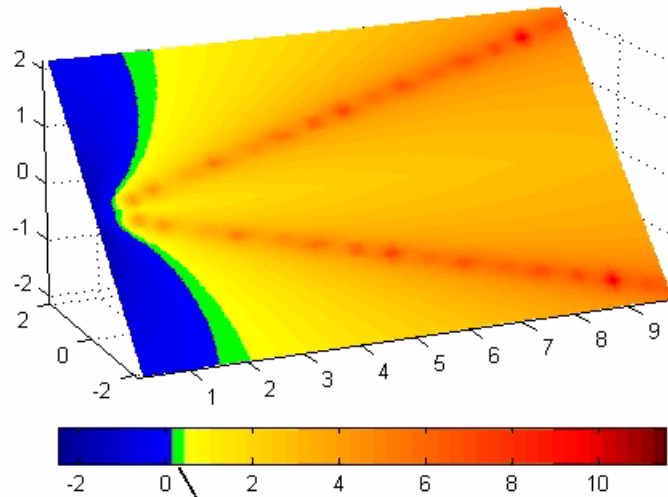

Note that green cell is not centered around zero.

To recenter the green cell around zero, select the blue, green, and yellow node pointers (left-click blue, **Shift+click** yellow) and move them as a group using the left arrow key. Watch the colorbar in the figure window to see when the green color is centered around zero.

colormapeditor

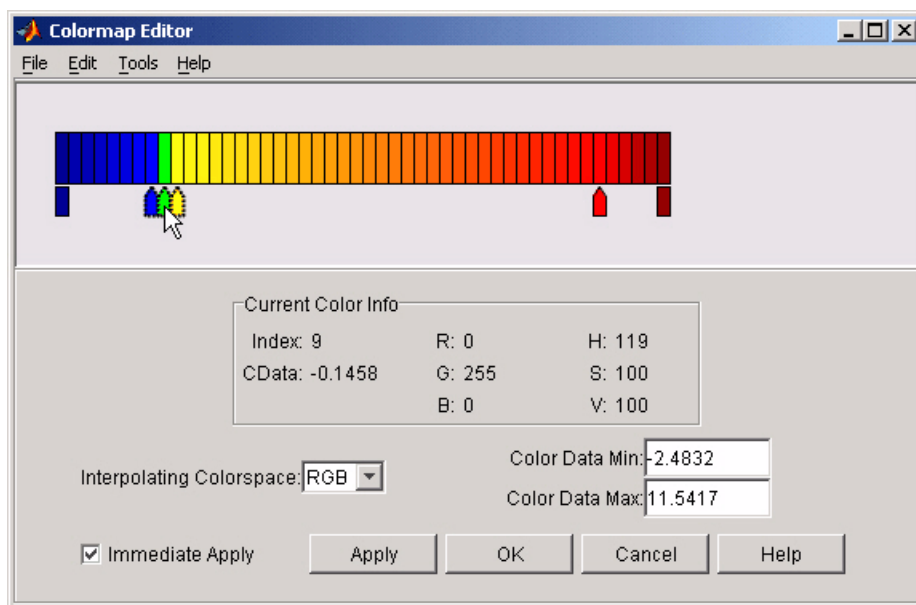

The slice plane now has the desired range of colors for negative, zero, and positive data.

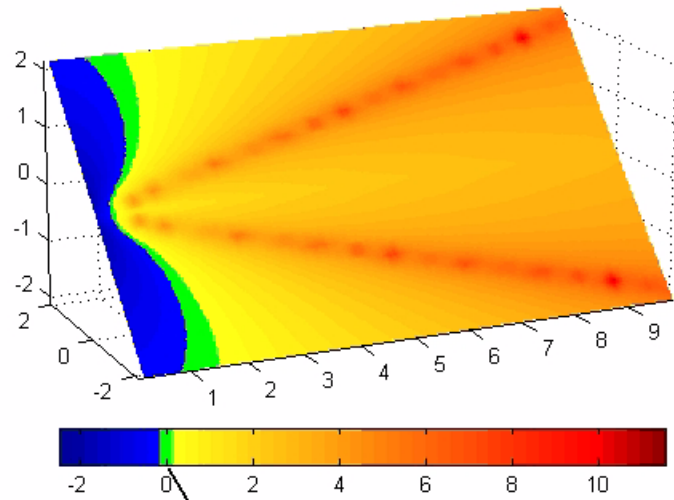

Green cell is now centered around zero.

- 6 Increase the orange-red coloring in the slice by moving the red node pointer toward the yellow node.

colormapeditor

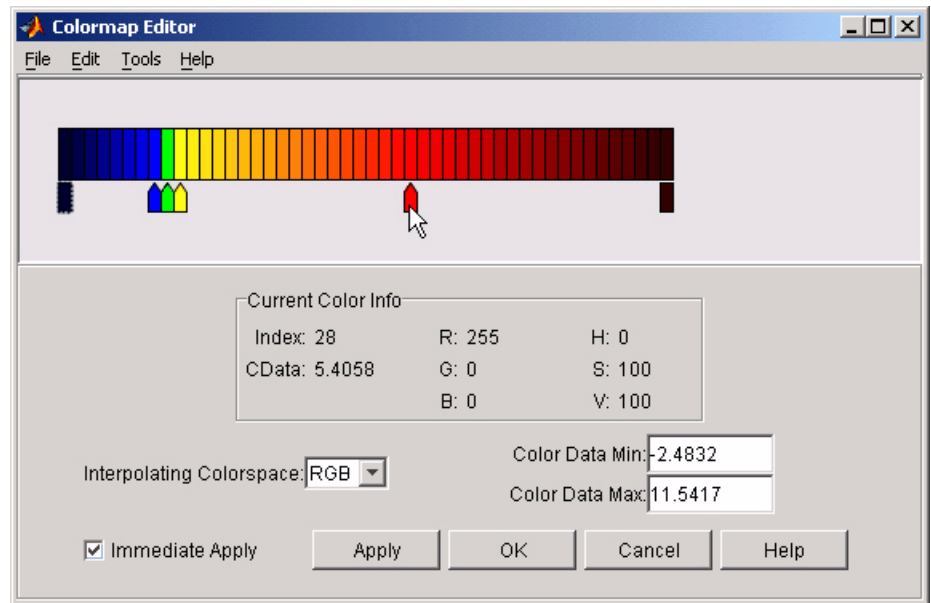

- 7 Darken the endpoints to bring out more detail in the extremes of the data. Double-click the end nodes to display the color picker. Set the red endpoint to the RGB value [50 0 0] and set the blue endpoint to the RGB value [0 0 50].

The slice plane coloring now matches the example objectives.

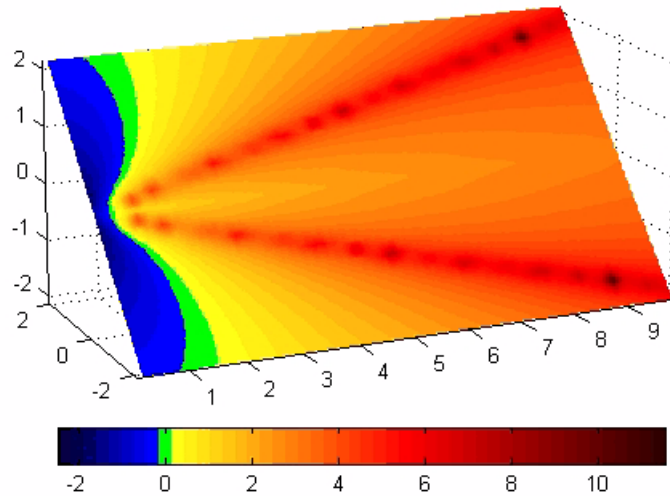

Saving the Modified Colormap

You can save the modified colormap using the `colormap` function or the figure `Colormap` property.

After you have applied your changes, save the current figure colormap in a variable:

```
mycmap = get(fig,'Colormap');
```

To use this colormap in another figure, set that figure's `Colormap` property:

```
set(new_fig,'Colormap',mycmap)
```

To save your modified colormap in a MAT-file, use the `save` command to save the `mycmap` workspace variable:

```
save('MyColormaps','mycmap')
```

To use your saved colormap in another MATLAB session, load the variable into the workspace and assign the colormap to the figure:

colormapeditor

```
load('MyColormaps','mycmap')  
set(fig,'Colormap',mycmap)
```

See Also

colormap | get | load | propertyeditor | save | set

How To

- “Colormaps”

ColorSpec (Color Specification)

Purpose Color specification

Description ColorSpec is not a function; it refers to the three ways in which you specify color for MATLAB graphics:

- RGB triple
- Short name
- Long name

The short names and long names are MATLAB strings that specify one of eight predefined colors. The RGB triple is a three-element row vector whose elements specify the intensities of the red, green, and blue components of the color; the intensities must be in the range [0 1]. The following table lists the predefined colors and their RGB equivalents.

RGB Value	Short Name	Long Name
[1 1 0]	y	yellow
[1 0 1]	m	magenta
[0 1 1]	c	cyan
[1 0 0]	r	red
[0 1 0]	g	green
[0 0 1]	b	blue
[1 1 1]	w	white
[0 0 0]	k	black

Tips The eight predefined colors and any colors you specify as RGB values are not part of a figure's colormap, nor are they affected by changes to the figure's colormap. They are referred to as *fixed* colors, as opposed to *colormap* colors.

Some high-level functions (for example, `scatter`) accept a colorspec as an input argument and use it to set the CData of graphic objects they create. When using such functions, take care not to specify a colorspec

ColorSpec (Color Specification)

in a property/value pair that sets `CData`; values for `CData` are always `n`-length vectors or `n`-by-3 matrices, where `n` is the length of `XData` and `YData`, never strings.

Examples

To change the background color of a figure to green, specify the color with a short name, a long name, or an RGB triple. These statements generate equivalent results:

```
whitebg('g')
whitebg('green')
whitebg([0 1 0]);
```

You can use `ColorSpec` anywhere you need to define a color. For example, this statement changes the figure background color to pink:

```
set(gcf, 'Color', [1,0.4,0.6])
```

See Also

`bar` | `bar3` | `colordef` | `colormap` | `fill` | `fill3` | `whitebg` | `uicolor`

Purpose	Sparse column permutation based on nonzero count
Syntax	<code>j = colperm(S)</code>
Description	<p><code>j = colperm(S)</code> generates a permutation vector <code>j</code> such that the columns of <code>S(:, j)</code> are ordered according to increasing count of nonzero entries. This is sometimes useful as a preordering for LU factorization; in this case use <code>lu(S(:, j))</code>.</p> <p>If <code>S</code> is symmetric, then <code>j = colperm(S)</code> generates a permutation <code>j</code> so that both the rows and columns of <code>S(j, j)</code> are ordered according to increasing count of nonzero entries. If <code>S</code> is positive definite, this is sometimes useful as a preordering for Cholesky factorization; in this case use <code>chol(S(j, j))</code>.</p>
Algorithms	The algorithm involves a sort on the counts of nonzeros in each column.
Examples	<p>The n-by-n <i>arrowhead</i> matrix</p> <pre>A = [ones(1, n); ones(n-1, 1) speye(n-1, n-1)]</pre> <p>has a full first row and column. Its LU factorization, <code>lu(A)</code>, is almost completely full. The statement</p> <pre>j = colperm(A)</pre> <p>returns <code>j = [2:n 1]</code>. So <code>A(j, j)</code> sends the full row and column to the bottom and the rear, and <code>lu(A(j, j))</code> has the same nonzero structure as <code>A</code> itself.</p> <p>On the other hand, the Bucky ball example,</p> <pre>B = bucky</pre> <p>has exactly three nonzero elements in each row and column, so <code>j = colperm(B)</code> is the identity permutation and is no help at all for reducing fill-in with subsequent factorizations.</p>

colperm

See Also

`chol` | `colamd` | `lu` | `spparms` | `symamd` | `symrcm`

Purpose Convenience function for static .NET System.Delegate Combine method

Syntax `result = Combine(delegateA,delegateB)`

Description `result = Combine(delegateA,delegateB)` combines two delegates into a new delegate.

Input Arguments

delegateA
.NET System.Delegate object. The first delegate in the new delegate.

delegateB
.NET System.Delegate object. The last delegate in the new delegate.

Output Arguments

result
.NET System.Delegate object. A new delegate that delegates to the input delegate delegateA, then delegateB

Alternatives Use the static Combine method of the System.Delegate class.

See Also [Remove](#) | [RemoveAll](#)

How To

- “Combine and Remove .NET Delegates”

Related Links

- [MSDN System.Delegate.Combine Method reference page](#)

comet

Purpose 2-D comet plot

Syntax `comet(y)`
`comet(x,y)`
`comet(x,y,p)`
`comet(axes_handle,...)`

Description `comet(y)` displays a comet graph of the vector y . A comet graph is an animated graph in which a circle (the comet *head*) traces the data points on the screen. The comet *body* is a trailing segment that follows the head. The *tail* is a solid line that traces the entire function.

`comet(x,y)` displays a comet graph of vector y versus vector x .

`comet(x,y,p)` specifies a comet body of length $p \cdot \text{length}(y)$. p defaults to 0.1.

`comet(axes_handle,...)` plots into the axes with the handle `axes_handle` instead of into the current axes (`gca`).

Examples Create a simple comet graph:

```
t = 0:.01:2*pi;  
x = cos(2*t).*(cos(t).^2);  
y = sin(2*t).*(sin(t).^2);  
comet(x,y);
```

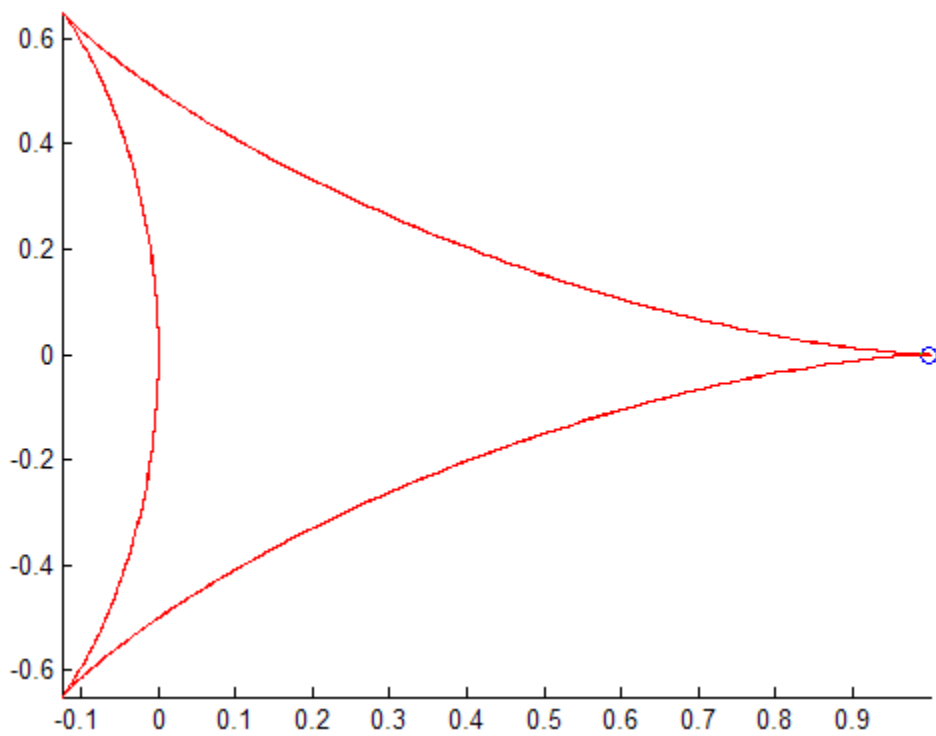
**See Also**

comet3

comet3

Purpose

3-D comet plot



Syntax

```
comet3(z)
comet3(x,y,z)
comet3(x,y,z,p)
comet3(axes_handle,...)
```

Description

A comet plot is an animated graph in which a circle (the comet *head*) traces the data points on the screen. The comet *body* is a trailing segment that follows the head. The *tail* is a solid line that traces the entire function.

`comet3(z)` displays a 3-D comet graph of the vector `z`.

`comet3(x,y,z)` displays a comet graph of the curve through the points `[x(i),y(i),z(i)]`.

`comet3(x,y,z,p)` specifies a comet body of length `p*length(y)`. `p` must be between 0 and 1.

`comet3(axes_handle,...)` plots into the axes with the handle `axes_handle` instead of into the current axes (`gca`).

Tips

The trace left by `comet3` is created by using an `EraseMode` of `none`, which means you cannot print the graph (you get only the comet head), and it disappears if you cause a redraw (for example, by resizing the window).

Examples

Create a 3-D comet graph.

```
t = -10*pi:pi/250:10*pi;
comet3((cos(2*t).^2).*sin(t),(sin(2*t).^2).*cos(t),t);
```

See Also

`comet`

Purpose Open Command History window, or select it if already open

Syntax `commandhistory`

Description `commandhistory` opens the MATLAB Command History window when it is closed, and selects the Command History window when it is open. The Command History window presents a log of the statements most recently run in the Command Window.

See Also `diary` | `prefdir` | `startup`

How To

- “Command History”

commandwindow

Purpose Open Command Window, or select it if already open

Syntax `commandwindow`

Description `commandwindow` opens the MATLAB Command Window when it is closed, and selects the Command Window when it is open.

Tips To determine the number of columns and rows that display in the Command Window, given its current size, use

```
matlab.desktop.commandwindow.size
```

The number of columns is based on the width of the Command Window. With the matrix display width preference set to 80 columns, the number of columns is always 80.

See Also `commandhistory` | `input` | `inputdlg`

How To

- “Optimize Desktop Layout for Limited Screen Space”
- “Set Command Window Preferences”

Purpose	Companion matrix
Syntax	<code>A = compan(u)</code>
Description	<code>A = compan(u)</code> returns the corresponding companion matrix whose first row is <code>-u(2:n)/u(1)</code> , where <code>u</code> is a vector of polynomial coefficients. The eigenvalues of <code>compan(u)</code> are the roots of the polynomial.
Examples	<p>The polynomial $(x - 1)(x - 2)(x + 3) = x^3 - 7x + 6$ has a companion matrix given by</p> <pre>u = [1 0 -7 6] A = compan(u) A = 0 7 -6 1 0 0 0 1 0</pre> <p>The eigenvalues are the polynomial roots:</p> <pre>eig(compan(u)) ans = -3.0000 2.0000 1.0000</pre> <p>This is also <code>roots(u)</code>.</p>
See Also	<code>eig</code> <code>poly</code> <code>polyval</code> <code>roots</code>

Purpose

Plot arrows emanating from origin



Syntax

```
compass(U,V)
compass(Z)
compass(...,LineStyle)
compass(axes_handle,...)
h = compass(...)
```

Description

A compass graph displays the vectors with components (U,V) as arrows emanating from the origin. U , V , and Z are in Cartesian coordinates and plotted on a circular grid.

`compass(U,V)` displays a compass graph having n arrows, where n is the number of elements in U or V . The location of the base of each arrow is the origin. The location of the tip of each arrow is a point relative to the base and determined by $[U(i),V(i)]$.

`compass(Z)` displays a compass graph having n arrows, where n is the number of elements in Z . The location of the base of each arrow is the origin. The location of the tip of each arrow is relative to the base as determined by the real and imaginary components of Z . This syntax is equivalent to `compass(real(Z),imag(Z))`.

`compass(...,LineStyle)` draws a compass graph using the line type, marker symbol, and color specified by `LineStyle`.

`compass(axes_handle,...)` plots into the axes with the handle `axes_handle` instead of into the current axes (`gca`).

`h = compass(...)` returns handles to line objects.

Examples

Create Compass Graph

Create a compass graph of the eigenvalues of a random matrix.

```
rng(0,'twister') % initialize random number generator
```

```
M = randn(20,20);  
Z = eig(M);
```

```
figure  
compass(Z)
```

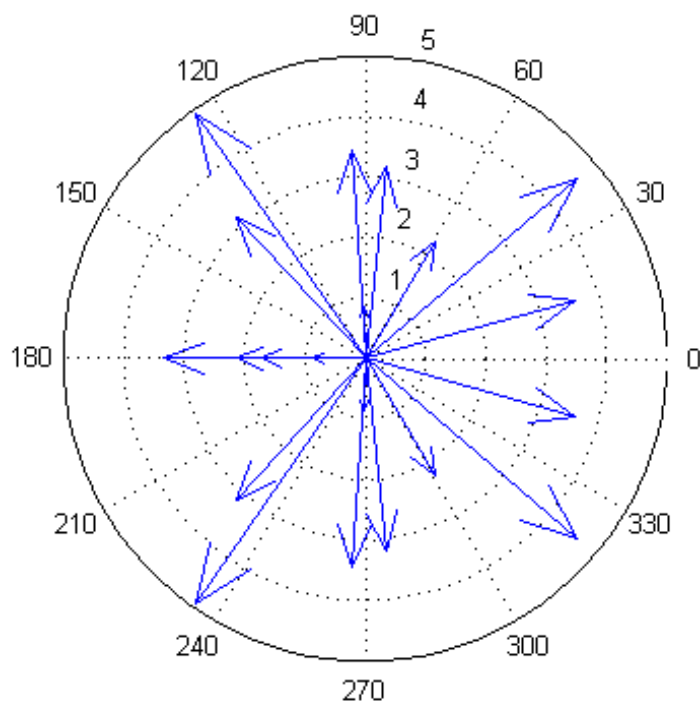
**See Also**

[feather](#) | [polar](#) | [LineSpec](#) | [quiver](#) | [rose](#)

complex

Purpose Create complex array

Syntax
`z = complex(a,b)`
`z = complex(x)`

Description `z = complex(a,b)` creates a complex output, `z`, from two real inputs, such that $z = a + bi$.

The `complex` function provides a useful substitute for expressions, such as $a + 1i*b$ or $a + 1j*b$, when

- `a` and `b` are not `double` or `single`
- `b` is all zeros

`z = complex(x)` returns the complex equivalent of `x`, such that `isreal(z)` returns logical 0 (`false`).

- If `x` is real, then `z` is $x + 0i$.
- If `x` is complex, then `z` is identical to `x`.

Input Arguments

a - Real component

scalar | vector | matrix | multidimensional array

Real component, specified as a scalar, vector, matrix, or multidimensional array.

The size of `a` must match the size of `b`, unless one is a scalar. If either `a` or `b` is a scalar, MATLAB expands the scalar to match the size of the other input.

`a` and `b` must be the same data type with the following exceptions:

- `single` can combine with `double`.
- `scalar double` can combine with an integer data type.

Data Types

single | double | int8 | int16 | int32 | int64 | uint8 |
uint16 | uint32 | uint64

b - Imaginary component

scalar | vector | matrix | multidimensional array

Imaginary component, specified as a scalar, vector, matrix, or multidimensional array.

The size of **b** must match the size of **a**, unless one is a scalar. If either **a** or **b** is a scalar, MATLAB expands the scalar to match the size of the other input.

a and **b** must be the same data type with the following exceptions:

- single can combine with double.
- scalar double can combine with an integer data type.

Data Types

single | double | int8 | int16 | int32 | int64 | uint8 |
uint16 | uint32 | uint64

x - Input array

scalar | vector | matrix | multidimensional array

Input array, specified as a scalar, vector, matrix, or multidimensional array.

Data Types

single | double | int8 | int16 | int32 | int64 | uint8 |
uint16 | uint32 | uint64

Complex Number Support: Yes

Output Arguments**z - Complex array**

scalar | vector | matrix | multidimensional array

Complex array, returned as a scalar, vector, matrix, or multidimensional array.

The size of **z** is the same as the input arguments.

The following describes the data type of `z`, when `a` and `b` have different data types.

- If either `a` or `b` is `single`, then `z` is `single`.
- If either `a` or `b` is an integer data type, then `z` is the same integer data type.

Examples

Complex Scalar from Two Real Scalars

Use the `complex` function to create the complex scalar, $3 + 4i$.

```
z = complex(3,4)
```

```
z =
```

```
3.0000 + 4.0000i
```

Complex Vector from Two Complex Vectors

Create a complex `uint8` vector from two real `uint8` vectors.

```
a = uint8([1;2;3;4]);
```

```
b = uint8([2;2;7;7]);
```

```
z = complex(a,b)
```

```
z =
```

```
1 + 2i
```

```
2 + 2i
```

```
3 + 7i
```

```
4 + 7i
```

The size of `z`, 4-by-1, is the same as the size of the input arguments.

Complex Scalar from One Real Scalar

Create a complex scalar with zero imaginary part.

```
z = complex(12)
```

`z =`

```
12.0000 + 0.0000i
```

Verify that `z` is complex.

```
isreal(z)
```

`ans =`

```
0
```

Tips

- If `b` contains only zeros, then `z` is complex and the value of all its imaginary components is 0. In contrast, the addition `a + 0i` returns a strictly real result.

See Also

`abs` | `angle` | `conj` | `i` | `imag` | `isreal` | `j` | `real`

Concepts

- “Complex Numbers”

Tiff.computeStrip

Purpose Index number of strip containing specified coordinate

Syntax
`stripNumber = tiffobj.computeStrip(row)`
`stripNumber = tiffobj.computeStrip(row,plane)`

Description `stripNumber = tiffobj.computeStrip(row)` returns the index number of the strip containing the given row. The value of row must be one-based.

`stripNumber = tiffobj.computeStrip(row,plane)` returns the index number of the strip containing the given row in the specified plane, if the value of the PlanarConfiguration tag is `Tiff.PlanarConfiguration.Separate`. The values of row and plane must be one-based.

`computeStrip` clamps out-of-range coordinate values to the bounds of the image.

Examples Determine Index Number of Strip

Determine the index number of the strip containing a row in the second image of a file.

Create a Tiff object associated with the example file, `example.tif`, and make the second image the current directory.

```
t = Tiff('example.tif','r');  
t.setDirectory(2);
```

Get the number of rows in the image. Then, get the index of the strip containing the middle row.

```
numRows = t.getTag('ImageLength');  
stripNumber = t.computeStrip(numRows/2)
```

```
stripNumber =
```

4

Close the Tiff object.

```
t.close();
```

References

This method corresponds to the TIFFComputeStrip function in the LibTIFF C API. To use this method, you must be familiar with the TIFF specification and technical notes. View this documentation at LibTIFF - TIFF Library and Utilities.

See Also

Tiff.computeTile

Tutorials

- “Exporting Image Data and Metadata to TIFF Files”
- “Reading Image Data and Metadata from TIFF Files”

Tiff.computeTile

Purpose Index number of tile containing specified coordinates

Syntax

```
tileNumber = tiffobj.computeTile([row col])  
tileNumber = tiffobj.computeTile([row col],plane)
```

Description

`tileNumber = tiffobj.computeTile([row col])` returns the index number of the tile containing the pixel specified by the one-based indices, `row` and `col`.

`tileNumber = tiffobj.computeTile([row col],plane)` returns the index number of the tile containing the pixel specified by the indices in the specified plane, if the value of the `PlanarConfiguration` tag is `Tiff.PlanarConfiguration.Separate`. The `row`, `column`, and `plane` coordinate values are one-based.

`computeTile` clamps out-of-range coordinate values to the bounds of the image.

Examples **Get Index Number of Tile Containing Last Pixel**

Open a Tiff object and get the dimensions of the image to calculate coordinates.

```
t = Tiff('example.tif','r');  
numRows = t.getTag('ImageLength');  
numCols = t.getTag('ImageWidth');
```

Get the ID number of the tile containing the coordinates.

```
tileNum = t.computeTile([numRows numCols])
```

```
tileNum =
```

```
    110
```

Close the Tiff object.

```
t.close();
```

References

This method corresponds to the `TIFFComputeTile` function in the LibTIFF C API. To use this method, you must be familiar with the TIFF specification and technical notes. View this documentation at [LibTiff - TIFF Library and Utilities](#).

See Also

`Tiff.computeStrip`

Tutorials

- “Exporting Image Data and Metadata to TIFF Files”
- “Reading Image Data and Metadata from TIFF Files”

computer

Purpose Information about computer on which MATLAB software is running

Syntax

```
str = computer
archstr = computer('arch')
[str,maxsize] = computer
[str,maxsize, endian] = computer
```

Description `str = computer` returns the string `str` with the computer type on which MATLAB is running.

`archstr = computer('arch')` returns the string `archstr` which is used by the mex command `-arch` switch.

`[str,maxsize] = computer` returns the integer `maxsize`, the maximum number of elements allowed in an array with this version of MATLAB.

`[str,maxsize, endian] = computer` returns either 'L' for little-endian byte ordering or 'B' for big-endian byte ordering.

Platform	Word Size	archstr	maxsize	endian	ispc	isunix	ismac	
Microsoft Windows	32-bit	PCWIN	win32	2 ³¹ - 1	L	1	0	0
	64-bit	PCWIN64	win64	2 ⁴⁸ - 1	L	1	0	0
Linux	64-bit	GLNXA64	glnxa64	2 ⁴⁸ - 1	L	0	1	0
Apple Macintosh	64-bit	MACI64	maci64	2 ⁴⁸ - 1	L	0	1	1

Tips In some cases, both 32-bit and 64-bit versions of MATLAB can run on the same platform. In this case, the value returned by `computer` reflects which of these are running. For example, if you run a 32-bit version of MATLAB on a Windows x64 platform, `computer` returns `PCWIN`, indicating that the 32-bit version is running. You can get this

information and the value of `archstr` from the **Help** menu, as described in “Information About your Installation”.

See Also

`getenv` | `setenv` | `ispc` | `isunix` | `ismac`

cond

Purpose Condition number with respect to inversion

Syntax
`c = cond(X)`
`c = cond(X,p)`

Description The *condition number* of a matrix measures the sensitivity of the solution of a system of linear equations to errors in the data. It gives an indication of the accuracy of the results from matrix inversion and the linear equation solution. Values of `cond(X)` and `cond(X,p)` near 1 indicate a well-conditioned matrix.

`c = cond(X)` returns the 2-norm condition number, the ratio of the largest singular value of X to the smallest.

`c = cond(X,p)` returns the matrix condition number in p -norm:

$\text{norm}(X,p) * \text{norm}(\text{inv}(X),p)$

If p is...	Then <code>cond(X,p)</code> returns the...
1	1-norm condition number
2	2-norm condition number
'fro'	Frobenius norm condition number
inf	Infinity norm condition number

Algorithms The algorithm for `cond` (when $p = 2$) uses the singular value decomposition, `svd`. When the input matrix is sparse, `cond` ignores any specified p value and calls `condest`.

See Also `condeig` | `condest` | `norm` | `normest` | `rank` | `rcond` | `svd`

Purpose Condition number with respect to eigenvalues

Syntax `c = condeig(A)`
`[V,D,s] = condeig(A)`

Description `c = condeig(A)` returns a vector of condition numbers for the eigenvalues of A. These condition numbers are the reciprocals of the cosines of the angles between the left and right eigenvectors.

`[V,D,s] = condeig(A)` is equivalent to

```
[V,D] = eig(A);  
s = condeig(A);
```

Large condition numbers imply that A is near a matrix with multiple eigenvalues.

See Also `balance` | `cond` | `eig`

condest

Purpose 1-norm condition number estimate

Syntax
`c = condest(A)`
`c = condest(A,t)`
`[c,v] = condest(A)`

Description `c = condest(A)` computes a lower bound `c` for the 1-norm condition number of a square matrix `A`.
`c = condest(A,t)` changes `t`, a positive integer parameter equal to the number of columns in an underlying iteration matrix. Increasing the number of columns usually gives a better condition estimate but increases the cost. The default is `t = 2`, which almost always gives an estimate correct to within a factor 2.

`[c,v] = condest(A)` also computes a vector `v` which is an approximate null vector if `c` is large. `v` satisfies $\text{norm}(A*v,1) = \text{norm}(A,1)*\text{norm}(v,1)/c$.

Note `condest` invokes `rand`. If repeatable results are required then use `rng` to set the random number generator to its startup settings before using `condest`.

`rng('default')`

Tips This function is particularly useful for sparse matrices.

Algorithms `condest` is based on the 1-norm condition estimator of Hager [1] and a block-oriented generalization of Hager's estimator given by Higham and Tisseur [2]. The heart of the algorithm involves an iterative search to

estimate $\|A^{-1}\|_1$ without computing A^{-1} . This is posed as the convex but nondifferentiable optimization problem $\max \|A^{-1}\mathbf{x}\|_1$ subject to $\|\mathbf{x}\|_1 = 1$

References

[1] William W. Hager, "Condition Estimates," *SIAM J. Sci. Stat. Comput.* 5, 1984, 311-316, 1984.

[2] Nicholas J. Higham and Françoise Tisseur, "A Block Algorithm for Matrix 1-Norm Estimation with an Application to 1-Norm Pseudospectra," *SIAM J. Matrix Anal. Appl.*, Vol. 21, 1185-1201, 2000.

See Also

cond | norm | normest

Purpose Plot velocity vectors as cones in 3-D vector field

Syntax

```
coneplot(X,Y,Z,U,V,W,Cx,Cy,Cz)
coneplot(U,V,W,Cx,Cy,Cz)
coneplot(...,s)
coneplot(...,color)
coneplot(...,'quiver')
coneplot(...,'method')
coneplot(X,Y,Z,U,V,W,'nointerp')
coneplot(axes_handle,...)
h = coneplot(...)
```

Description `coneplot(X,Y,Z,U,V,W,Cx,Cy,Cz)` plots velocity vectors as cones pointing in the direction of the velocity vector and having a length proportional to the magnitude of the velocity vector. `X, Y, Z` define the coordinates for the vector field. `U, V, W` define the vector field. These arrays must be the same size, monotonic, and represent a Cartesian, axis-aligned grid (such as the data produced by `meshgrid`). `Cx, Cy, Cz` define the location of the cones in the vector field. The section “Specifying Starting Points for Stream Plots” in *Visualization Techniques* provides more information on defining starting points.

`coneplot(U,V,W,Cx,Cy,Cz)` (omitting the `X, Y, and Z` arguments) assumes `[X,Y,Z] = meshgrid(1:n,1:m,1:p)`, where `[m,n,p]=size(U)`.

`coneplot(...,s)` automatically scales the cones to fit the graph and then stretches them by the scale factor `s`. If you do not specify a value for `s`, `coneplot` uses a value of 1. Use `s = 0` to plot the cones without automatic scaling.

`coneplot(...,color)` interpolates the array `color` onto the vector field and then colors the cones according to the interpolated values. The size of the `color` array must be the same size as the `U, V, W` arrays. This option works only with cones (that is, not with the `quiver` option).

`coneplot(...,'quiver')` draws arrows instead of cones (see `quiver3` for an illustration of a quiver plot).

`coneplot(..., 'method')` specifies the interpolation method to use. *method* can be `linear`, `cubic`, or `nearest`. `linear` is the default. (See `interp3` for a discussion of these interpolation methods.)

`coneplot(X, Y, Z, U, V, W, 'nointerp')` does not interpolate the positions of the cones into the volume. The cones are drawn at positions defined by `X`, `Y`, `Z` and are oriented according to `U`, `V`, `W`. Arrays `X`, `Y`, `Z`, `U`, `V`, `W` must all be the same size.

`coneplot(axes_handle, ...)` plots into the axes with the handle `axes_handle` instead of into the current axes (`gca`).

`h = coneplot(...)` returns the handle to the patch object used to draw the cones. You can use the `set` command to change the properties of the cones.

`coneplot` automatically scales the cones to fit the graph, while keeping them in proportion to the respective velocity vectors.

Examples

Plot the velocity vector cones for vector volume data representing the motion of air through a rectangular region of space:

Load the data. The `winds` data set contains six 3-D arrays: `u`, `v`, and `w` specify the vector components at each of the coordinates specified in `x`, `y`, and `z`. The coordinates define a lattice grid structure where the data is sampled within the volume. `load wind`.

```
load wind
```

Now establish the range of the data to place the slice planes and to specify where you want the cone plots (`min`, `max`):

```
xmin = min(x(:));  
xmax = max(x(:));  
ymin = min(y(:));  
ymax = max(y(:));  
zmin = min(z(:));
```

Use `daspect` to set the data aspect ratio of the axes before calling `coneplot`.

```
daspect([2,2,1])
```

Decide where in data space you want to plot cones. This example selects the full range of x and y in eight steps and the range 3 to 15 in four steps in z using `linspace` and `meshgrid`.

```
xrange = linspace(xmin,xmax,8);  
yrange = linspace(ymin,ymax,8);  
zrange = 3:4:15;  
[cx cy cz] = meshgrid(xrange,yrange,zrange);
```

Draw the cones, setting the scale factor to 5 to make the cones larger than the default size:

```
hcones = coneplot(x,y,z,u,v,w,cx,cy,cz,5);
```

Use the `jet` colormap:

```
colormap jet
```

Set the coloring of each cone using `FaceColor` and `EdgeColor`:

```
set(hcones,'FaceColor','red','EdgeColor','none')
```

Calculate the magnitude of the vector field (which represents wind speed) to generate scalar data for the `slice` command:

```
hold on  
wind_speed = sqrt(u.^2 + v.^2 + w.^2);
```

Create slice planes along the x -axis at $xmin$ and $xmax$, along the y -axis at $ymax$, and along the z -axis at $zmin$:

```
hsurfaces = slice(x,y,z,wind_speed,[xmin,xmax],ymax,zmin);
```

Specify interpolated face color so the slice coloring indicates wind speed, and do not draw edges (`hold`, `slice`, `FaceColor`, `EdgeColor`):

```
set(hsurfaces,'FaceColor','interp','EdgeColor','none')  
hold off
```

Use the `axis` command to set the axis limits equal to the range of the data. `axis tight`. Orient the view to azimuth = 30 and elevation = 40. (`rotate3d` is a useful command for selecting the best view.)

```
view(30,40);axis off
```

Select perspective projection to provide a more realistic looking volume using `camproj`:

```
camproj perspective;
```

Zoom in on the scene a little to make the plot as large as possible using `camzoom`:

```
camzoom(1.5)
```

The light source affects both the slice planes (surfaces) and the cone plots (patches). However, you can set the lighting characteristics of each independently.

Add a light source to the right of the camera and use Gouraud lighting to give the cones and slice planes a smooth, three-dimensional appearance using `camlight` and `lighting`:

```
camlight right; lighting gouraud
```

Increase the value of the `AmbientStrength` property for each slice plane to improve the visibility of the dark blue colors:

```
set(hsurfaces,'AmbientStrength',0.6)
```

Increase the value of the `DiffuseStrength` property of the cones to brighten particularly those cones not showing specular reflections:

```
set(hcones,'DiffuseStrength',0.8)
```

coneplot

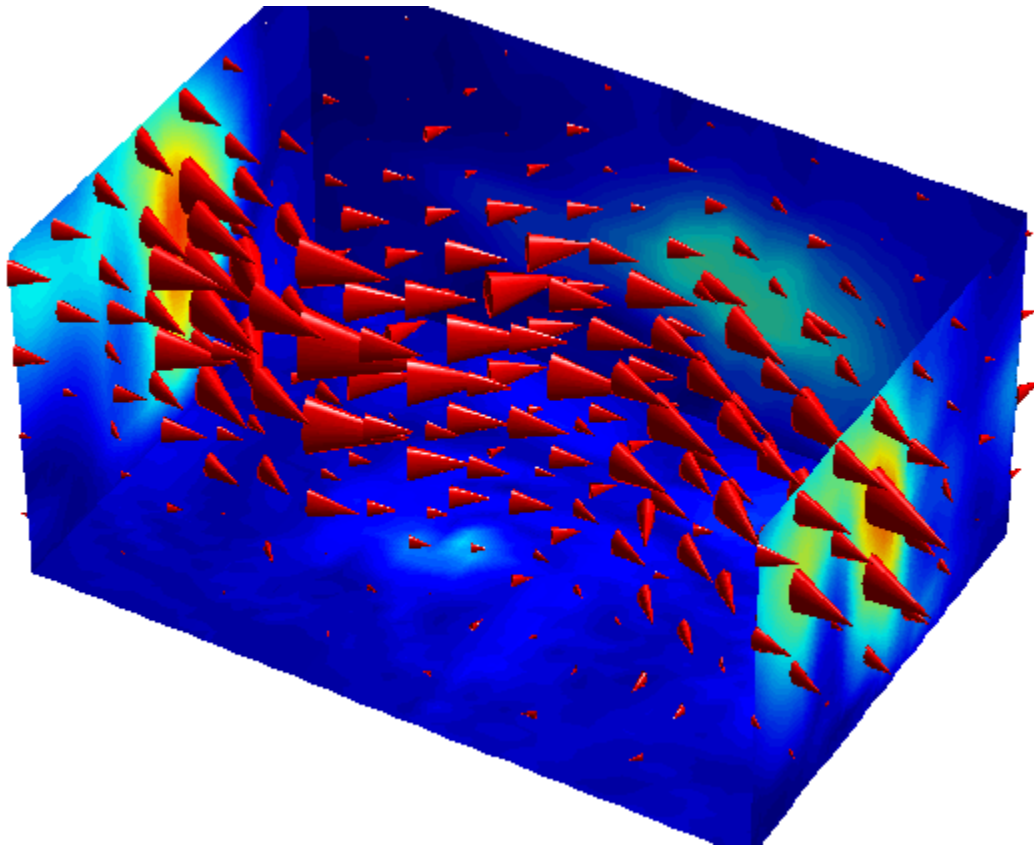

See Also

[isosurface](#) | [patch](#) | [reducevolume](#) | [smooth3](#) | [streamline](#) | [stream2](#) | [stream3](#) | [subvolume](#)

Tutorials

- “Overview of Volume Visualization”

Purpose Complex conjugate

Syntax `ZC = conj(Z)`

Description `ZC = conj(Z)` returns the complex conjugate of the elements of Z.

Algorithms If Z is a complex array:

`conj(Z) = real(Z) - i*imag(Z)`

See Also *i* | *j* | `imag` | `real`

continue

Purpose Pass control to next iteration of `for` or `while` loop

Syntax `continue`

Description `continue` temporarily interrupts the execution of a program loop, skipping any remaining statements in the body of the loop for the current pass. The `continue` statement does not cause an immediate exit from the loop as a `break` or `return` statement would do, but instead continues within the loop for as long as the stated `for` or `while` condition holds true.

A `continue` statement in a *nested* loop behaves in the same manner. Execution resumes at the `for` or `while` statement of the loop in which the `continue` statement was encountered, and reenters the loop if the stated condition evaluates to `true`.

Examples Count the number of lines of code in the file `magic.m`, skipping all blank lines and comments.

```
fid = fopen('magic.m','r');
count = 0;
while ~feof(fid)
    line = fgetl(fid);
    if isempty(line) || strncmp(line,'% ',1) || ~ischar(line)
        continue
    end
    count = count + 1;
end
fprintf('%d lines\n',count);
fclose(fid);
```

See Also `for` | `while` | `end` | `break` | `return`

Purpose Contour plot of matrix



Syntax

```
contour(Z)
contour(Z,n)
contour(Z,v)
contour(X,Y,Z)
contour(X,Y,Z,n)
contour(X,Y,Z,v)
contour(...,LineStyle)
contour(axes_handle,...)
[C,h] = contour(...)
```

Description A contour plot displays isolines of matrix Z . Label the contour lines using `clabel`.

`contour(Z)` draws a contour plot of matrix Z , where Z is interpreted as heights with respect to the x - y plane. Z must be at least a 2-by-2 matrix that contains at least two different values. The number of contour lines and the values of the contour lines are chosen automatically based on the minimum and maximum values of Z . The ranges of the x - and y -axis are $[1:n]$ and $[1:m]$, where $[m,n] = \text{size}(Z)$.

`contour(Z,n)` draws a contour plot of matrix Z with n contour levels where n is a scalar.

`contour(Z,v)` draws a contour plot of matrix Z with contour lines at the data values specified in the monotonically increasing vector v . The number of contour levels is equal to `length(v)`. Specifying the vector v sets the `LevelListMode` to manual to allow user control over contour levels. To display a single contour line at a particular value, define v as a two-element vector with both elements equal to the desired contour level. For example, to draw a single contour of level i , use `contour(Z,[i i])`.

`contour(X,Y,Z)`, `contour(X,Y,Z,n)`, and `contour(X,Y,Z,v)` draw contour plots of Z using X and Y to determine the x - and y -axis limits.

- If X and Y are vectors, then the length of X must equal the number of columns in Z and the length of Y must equal the number of rows in Z .
- If X and Y are matrices, then their sizes must equal the size of Z .

If X or Y is irregularly spaced, then `contour` calculates contours using a regularly spaced contour grid, and then transforms the data to X or Y .

`contour(...,LineStyle)` draws the contours using the line type and color specified by `LineStyle`. `contour` ignores marker symbols.

`contour(axes_handle,...)` plots into axes `axes_handle` instead of `gca`.

`[C,h] = contour(...)` returns a contour matrix, C , that contains the data that defines the contour lines, and a handle, h , to a `contourgroup` object. The `clabel` function uses contour matrix C to label the contour lines. `ContourMatrix` is also a read-only `contourgroup` property that you can obtain from the returned handle.

Use contour object properties to control the contour plot appearance.

Tips

- The contour function cannot determine if there are discontinuities in the input data. You can add NaN values to the data to prevent drawing the contour lines in those regions.

Examples

Create Contour Plot

Use the `meshgrid` function to generate matrices X and Y . Create a third matrix, Z , and plot its contours.

```
x = linspace(-2*pi,2*pi);
y = linspace(0,4*pi);
[X,Y] = meshgrid(x,y);
Z = sin(X)+cos(Y);
```

```
figure
contour(X,Y,Z)
```

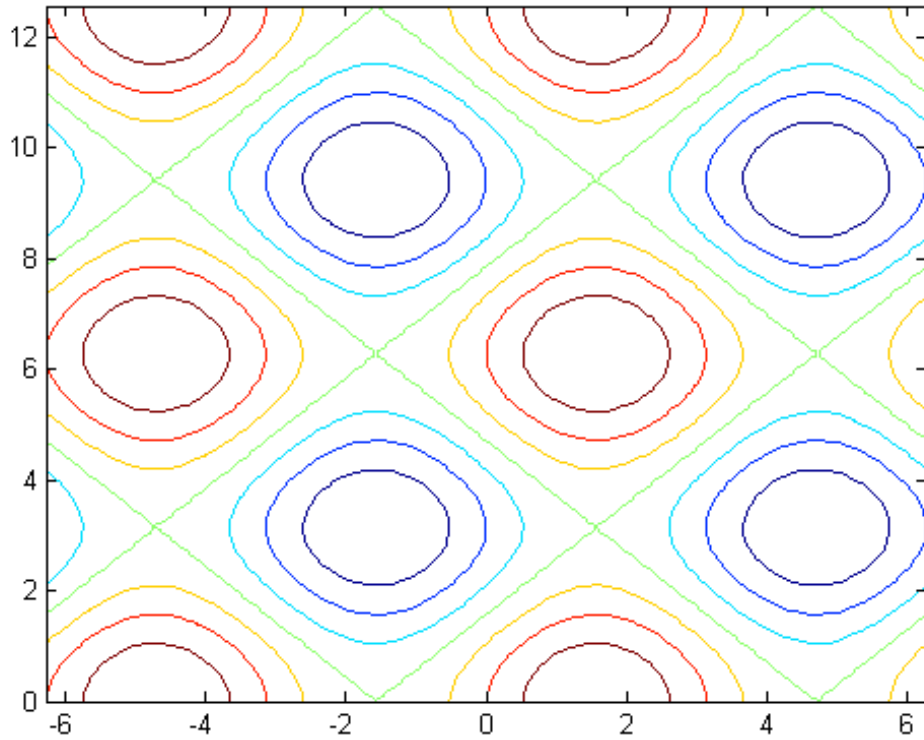

Specify Number of Contour Lines

Store the data from the peaks function in matrices X, Y, and Z. Plot 20 contours of the data in Z.

```
[X,Y,Z] = peaks;  
figure  
contour(X,Y,Z,20)
```

contour

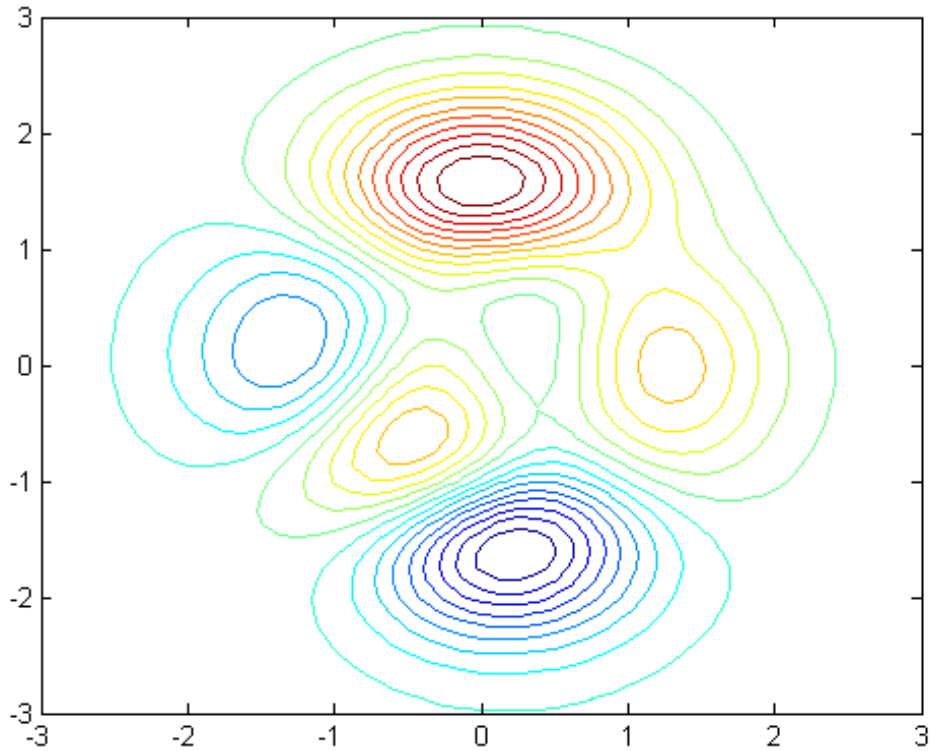

Display Contour Labels

Set up matrices X, Y, and Z. Create a contour plot and display the contour labels by setting the ShowText property to on.

```
x = -2:0.2:2;  
y = -2:0.2:3;  
[X,Y] = meshgrid(x,y);  
Z = X.*exp(-X.^2-Y.^2);
```

```
figure  
contour(X,Y,Z,'ShowText','on')
```

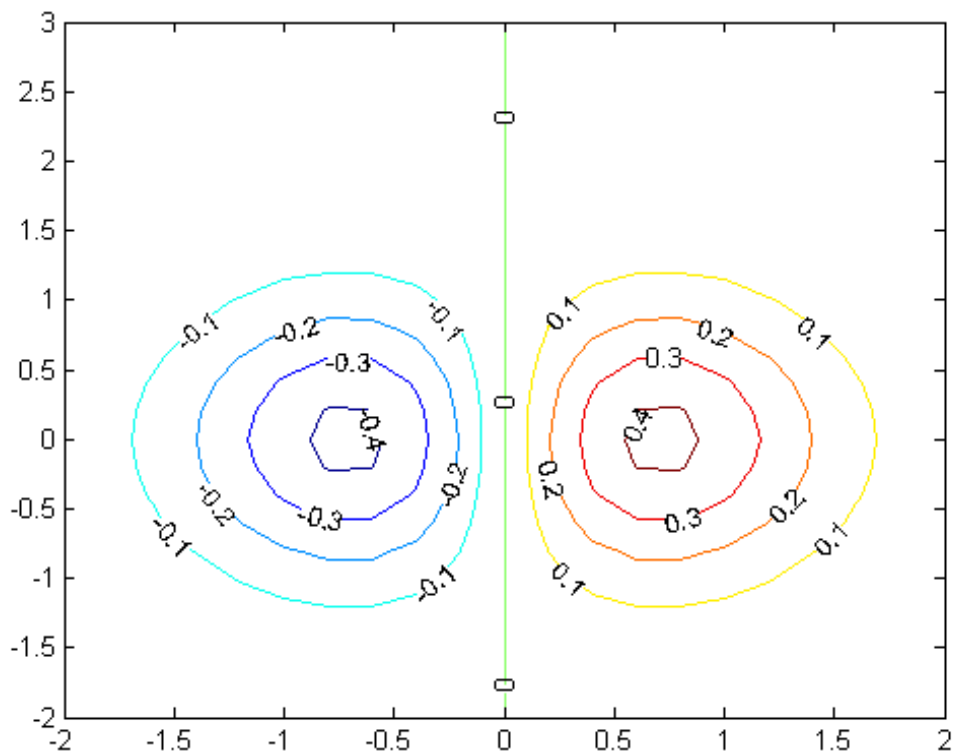

Display Single Contour Line

Create a contour plot of the peaks function and display only one contour level at $Z = 1$.

```
x = -3:0.125:3;  
y = -3:0.125:3;
```

contour

```
[X,Y] = meshgrid(x,y);  
Z = peaks(X,Y);  
v = [1,1];
```

```
figure  
contour(X,Y,Z,v);
```

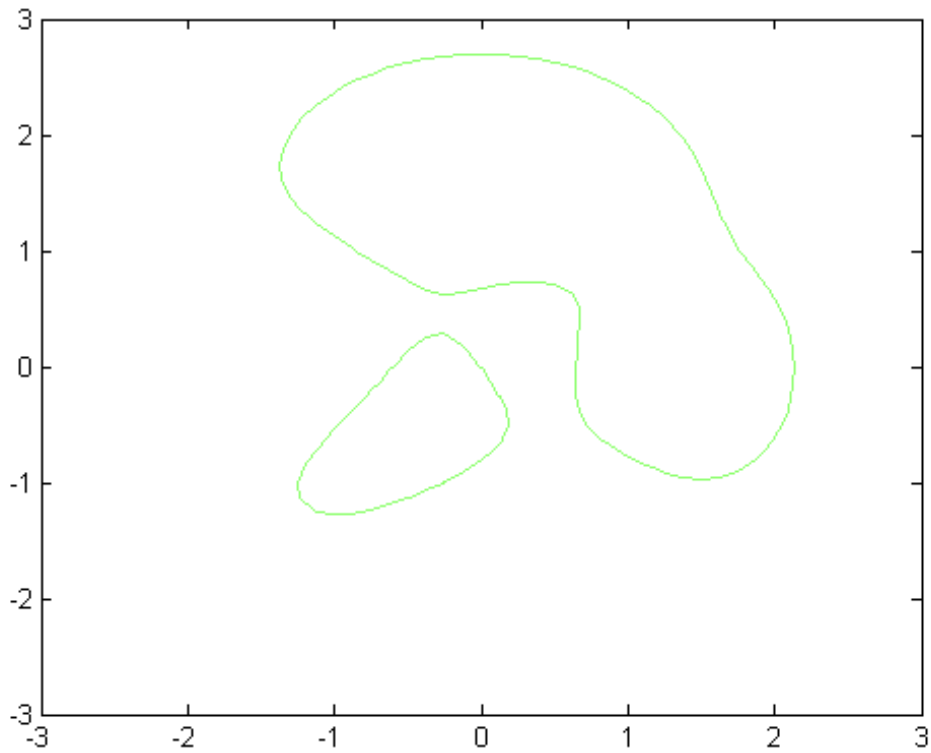

See Also

[clabel](#) | [contourf](#) | [contour3](#) | [contourc](#) | [quiver](#) | [contourgroup](#)
[properties](#) | [text](#) [properties](#)

How To

- “Label Contour Plot Levels”
- “Highlight Specific Contour Levels”

contour3

Purpose 3-D contour plot



Syntax

```
contour3(Z)
contour3(Z,n)
contour3(Z,v)
contour3(X,Y,Z)
contour3(X,Y,Z,n)
contour3(X,Y,Z,v)
contour3(...,LineStyle)
contour3(axes_handle,...)
[C,h] = contour3(...)
```

Description contour3 creates a 3-D contour plot of a surface defined on a rectangular grid.

contour3(Z) draws a contour plot of matrix Z in a 3-D view. Z is interpreted as heights with respect to the x-y plane. Z must be at least a 2-by-2 matrix that contains at least two different values. The number of contour levels and the values of contour levels are chosen automatically based on the minimum and maximum values of Z. The ranges of the x- and y-axis are [1:n] and [1:m], where [m,n] = size(Z).

contour3(Z,n) draws a contour plot of matrix Z with n contour levels in a 3-D view.

contour3(Z,v) draws a contour plot of matrix Z with contour lines at the values specified in vector v. The number of contour levels is equal to length(v). Specifying the vector v sets the LevelListMode to manual to allow user control over contour levels. To display a single contour line at a particular value, define v as a two-element vector with both elements equal to the desired contour level. For example, to draw a single contour of level i, use contour3(Z,[i i]).

contour3(X,Y,Z), contour3(X,Y,Z,n), and contour3(X,Y,Z,v) draw contour plots of Z using X and Y to determine the x- and y-axis limits.

- If X and Y are vectors, then the length of X must equal the number of columns in Z and the length of Y must equal the number of rows in Z .
- If X and Y are matrices, then their sizes must equal the size of Z .

If X or Y is irregularly spaced, then `contour3` calculates contours using a regularly spaced contour grid, and then transforms the data to X or Y .

`contour3(...,LineStyle)` draws the contour lines using the line type and color specified by `LineStyle`. `contour3` ignores marker symbols.

`contour3(axes_handle,...)` plots into the axes with the handle `axes_handle` instead of into the current axes (`gca`).

`[C,h] = contour3(...)` returns a contour matrix, C , that contains the data that defines the contour lines, and a handle, h , to an array of handles to graphics objects. The `clabel` function uses contour matrix C to label the contour lines. The graphic objects that `contour3` creates are patch objects, or if you specify a `LineStyle` argument, line objects.

Tips

If you do not specify `LineStyle`, the functions `colormap` and `caxis` control the color.

Label the contour lines using `clabel`.

`contour3(...)` works the same as `contour(...)` with these exceptions:

- The contours are drawn at their corresponding Z level.
- Multiple patch or line objects are created instead of a `contourgroup`.
- Calling `contour3` with trailing property-value pairs is not allowed.

Examples

Create 3-D Contour Plot

Set up matrices X and Y using the `meshgrid` function. Plot 30 contours of matrix Z .

```
x = -2:0.25:2;
[X,Y] = meshgrid(x);
Z = X.*exp(-X.^2-Y.^2);
```

contour3

`contour3(X,Y,Z,30)`

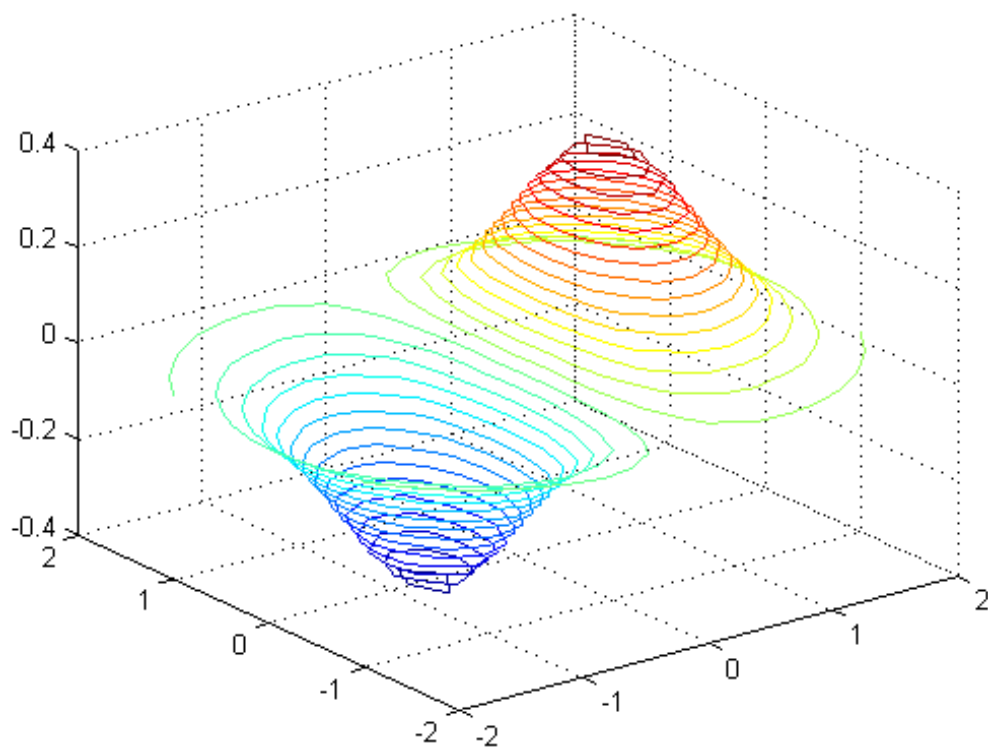

See Also

`contour` | `contourc` | `contourf` | `meshc` | `meshgrid` | `surfc` | `contourgroup` properties

Purpose

Low-level contour plot computation

Syntax

```
C = contourc(Z)
C = contourc(Z,n)
C = contourc(Z,v)
C = contourc(x,y,Z)
C = contourc(x,y,Z,n)
C = contourc(x,y,Z,v)
```

Description

`contourc` calculates the contour matrix `C` used by `contour`, `contour3`, and `contourf`. The values in `Z` determine the heights of the contour lines with respect to a plane. The contour calculations use a regularly spaced grid determined by the dimensions of `Z`.

`C = contourc(Z)` computes the contour matrix from data in matrix `Z`, where `Z` must be at least a 2-by-2 matrix. The contours are isolines in the units of `Z`. The number of contour lines and the corresponding values of the contour lines are chosen automatically.

`C = contourc(Z,n)` computes contours of matrix `Z` with `n` contour levels.

`C = contourc(Z,v)` computes contours of matrix `Z` with contour lines at the values specified in vector `v`. The length of `v` determines the number of contour levels. To compute a single contour of level `i`, use `contourc(Z,[i i])`.

`C = contourc(x,y,Z)`, `C = contourc(x,y,Z,n)`, and `C = contourc(x,y,Z,v)` compute contours of `Z` using vectors `x` and `y` to determine the x - and y -axis limits. `x` and `y` must be monotonically increasing.

Tips

`C` is a two-row matrix specifying all the contour lines. Each contour line defined in matrix `C` begins with a column that contains the value of the contour (specified by `v` and used by `clabel`), and the number of (x,y) vertices in the contour line. The remaining columns contain the data for the (x,y) pairs.

```
C = [value1 xdata(1) xdata(2) ...
```

contourc

```
xdata(dim1) value2 xdata(1) xdata(2) ... xdata(dim2)...  
dim1 ydata(1) ydata(2) ...  
ydata(dim1) dim2 ydata(1) ydata(2) ...  
ydata(dim2)];
```

Specifying irregularly spaced *x* and *y* vectors is not the same as contouring irregularly spaced data. If *x* or *y* is irregularly spaced, `contourc` calculates contours using a regularly spaced contour grid, then transforms the data to *x* or *y*.

See Also

`clabel` | `contour` | `contour3` | `contourf`

How To

- “The Contouring Algorithm”

Purpose Filled 2-D contour plot



Syntax

```
contourf(Z)
contourf(Z,n)
contourf(Z,v)
contourf(X,Y,Z)
contourf(X,Y,Z,n)
contourf(X,Y,Z,v)
contourf(...,LineStyle)
contourf(axes_handle,...)
contour(axes_handle,...)
[C,h] = contourf(...)
```

Description A filled contour plot displays isolines calculated from matrix *Z* and fills the areas between the isolines using constant colors corresponding to the current figure's colormap.

`contourf(Z)` draws a filled contour plot of matrix *Z*, where *Z* is interpreted as heights with respect to the *x-y* plane. *Z* must be at least a 2-by-2 matrix that contains at least two different values. The number of contour lines and the values of the contour lines are chosen automatically based on the minimum and maximum values of *Z*. The ranges of the *x*- and *y*-axis are `[1:n]` and `[1:m]`, where `[m,n] = size(Z)`.

`contourf(Z,n)` draws a filled contour plot of matrix *Z* with *n* contour levels.

`contourf(Z,v)` draws a filled contour plot of matrix *Z* with contour lines at the data values specified in the monotonically increasing vector *v*. Specifying the vector *v* sets the `LevelListMode` to manual to allow user control over contour levels. To display a single contour line at a particular value, define *v* as a two-element vector with both elements equal to the desired contour level. For example, to draw a single contour of level *i*, use `contourf(Z,[i i])`.

`contourf(X,Y,Z)`, `contourf(X,Y,Z,n)`, and `contourf(X,Y,Z,v)` draw filled contour plots of Z using X and Y to determine the x - and y -axis limits.

- If X and Y are vectors, then the length of X must equal the number of columns in Z and the length of Y must equal the number of rows in Z .
- If X and Y are matrices, then their sizes must equal the size of Z .

If X or Y is irregularly spaced, then `contourf` calculates contours using a regularly spaced contour grid, and then transforms the data to X or Y .

`contourf(...,LineStyle)` draws the contour lines using the line type and color specified by `LineStyle`. `contourf` ignores marker symbols.

`contourf(axes_handle,...)` plots into the axes with the handle `axes_handle` instead of into the current axes (`gca`).

`contour(axes_handle,...)` plots into axes `axes_handle` instead of `gca`.

`[C,h] = contourf(...)` returns a contour matrix, `C`, that contains the data that defines the contour lines, and a handle, `h`, to a `ContourGroup` object containing the filled contours. The `clabel` function uses contour matrix `C` to label the contour lines. `ContourMatrix` is also a read-only `ContourGroup` property that you can obtain from the returned handle.

Tips

Label the contour lines using `clabel`.

NaNs in the Z -data leave white holes with black borders in the contour plot.

Examples

Create Filled Contour Plot

Use the `peaks` function to define z as a 20-by-20 matrix. Create a filled contour plot of z with 10 contour lines.

```
Z = peaks(20);  
contourf(Z,10);
```

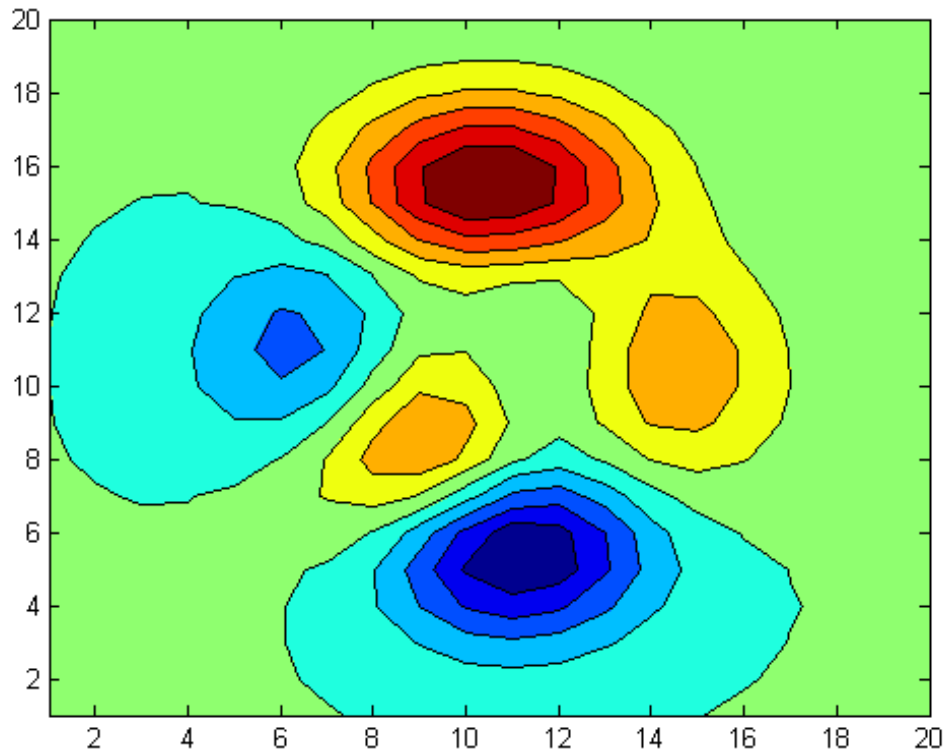
**See Also**

[clabel](#) | [contour](#) | [contour3](#) | [contourc](#) | [quiver](#) | [contourgroup](#)
[properties](#)

How To

- “Change Fill Colors for Contour Plot”

Contourgroup Properties

Purpose Define contourgroup properties

Modifying Properties You can set and query graphics object properties using the `set` and `get` commands or the Property Editor (`propertyeditor`).

Note that you cannot define default properties for contourgroup objects. See “Plot Objects” for more information on contourgroup objects.

Contourgroup Property Descriptions This section provides a description of properties. Curly braces { } enclose default values.

Annotation

`hg.Annotation` object (read-only)

Control the display of contourgroup objects in legends. Specifies whether this contourgroup object is represented in a figure legend.

Querying the `Annotation` property returns the handle of an `hg.Annotation` object. The `hg.Annotation` object has a property called `LegendInformation`, which contains an `hg.LegendEntry` object.

Once you have obtained the `hg.LegendEntry` object, you can set its `IconDisplayStyle` property to control whether the contourgroup object is displayed in a figure legend.

IconDisplayStyle Value	Purpose
<code>on</code>	Include the contourgroup object in a legend as one entry, but not its children objects
<code>off</code>	Do not include the contourgroup or its children in a legend (default)
<code>children</code>	Include only the children of the contourgroup as separate entries in the legend

Setting the IconDisplayStyle Property

These commands set the `IconDisplayStyle` of a graphics object with handle `hobj` to `children`, which causes each child object to have an entry in the legend:

```
hAnnotation = get(hobj, 'Annotation');  
hLegendEntry = get(hAnnotation, 'LegendInformation');  
set(hLegendEntry, 'IconDisplayStyle', 'children')
```

Using the IconDisplayStyle Property

See “Control Legend Content” for more information and examples.

BeingDeleted

`on` | `{off}` (read-only)

This object is being deleted. Mechanism to determine if objects are in the process of being deleted. MATLAB sets the `BeingDeleted` property to `on` when the object’s delete function callback is called (see the `DeleteFcn` property). It remains set to `on` while the delete function executes, after which the object no longer exists.

For example, an object’s delete function calls other functions that act on a number of different objects. If a function does not need to perform an action on an about-be-deleted object, it can check the object’s `BeingDeleted` property before acting.

BusyAction

`cancel` | `{queue}`

Callback queuing

Determines how MATLAB handles the execution of interrupting callbacks.

A *running* callback is the currently executing callback. The *interrupting* callback is the callback that tries to interrupt the

Contourgroup Properties

running callback. The `BusyAction` property of the *interrupting* callback determines how MATLAB handles its execution. When the `BusyAction` property is set to:

- 'queue' — Puts the *interrupting* callback in a queue to be processed after the *running* callback finishes execution.
- 'cancel' — Discards the *interrupting* callback as MATLAB finishes execution.

For information about how the `Interruptible` property of the callback controls whether other callbacks can interrupt the *running* callback, see the `Interruptible` property description.

`ButtonDownFcn`
string | function handle

Button press callback function. Executes whenever you press a mouse button while the pointer is over this object, but not over another graphics object. See the `HitTestArea` property for information about selecting objects of this type.

See the figure's `SelectionType` property to determine if modifier keys were also pressed.

This property can be:

- A string that is a valid MATLAB expression
- The name of a MATLAB file
- A function handle

Set this property to a function handle that references the callback. The expressions execute in the MATLAB workspace.

For information on the syntax of callback functions, see `Function Handle Callbacks`.

Children

array of graphics object handles

Children of the contourgroup object. An array containing the handles of all line objects parented to the contourgroup object (whether visible or not).

If a child object's `HandleVisibility` property is `callback` or `off`, its handle does not show up in this object's `Children` property. If you want the handle in the `Children` property, set the root `ShowHiddenHandles` property to `on`. For example:

```
set(0, 'ShowHiddenHandles', 'on')
```

Clipping

{on} | off

Clipping mode. MATLAB clips graphs to the axes plot box by default. If you set `Clipping` to `off`, portions of graphs appear outside the axes plot box. This occurs if you create a plot object, set `hold` to `on`, freeze axis scaling (`axis manual`), and then create a larger plot object.

ContourMatrix

2-by-n matrix (read-only)

Two-row matrix specifying all contour lines. Each contour line defined in the `ContourMatrix` begins with a column that contains the value of the contour (specified by the `LevelList` property and is used by `clabel`), and the number of (x,y) vertices in the contour line. The remaining columns contain the data for the (x,y) pairs.

For example:

```
C = [value1 xdata(1) xdata(2)...  
     value2 xdata(1) xdata(2)...;  
     dim1 ydata(1) ydata(2)...
```

Contourgroup Properties

```
dim2 ydata(1) ydata(2)...]
```

That is:

```
C = [C(1) C(2)...C(I)...C(N)]
```

where N is the number of contour levels, and:

```
C(i) = [ level(i) x(1) x(2)...x( numel(i));  
        numel(i) y(1) y(2)...y( numel(i))];
```

For further information, see `contour` and “The Contouring Algorithm”.

CreateFcn

function handle | cell array containing function handle and additional arguments | string (not recommended)

Callback function executed during object creation. Defines a callback that executes when MATLAB creates an object. The default is an empty array.

You must specify the callback during the creation of the object. For example:

```
graphicfcn(y, 'CreateFcn', @CallbackFcn)
```

where @*CallbackFcn* is a function handle that references the callback function and *graphicfcn* is the plotting function which creates this object.

MATLAB executes this routine after setting all other object properties. Setting this property on an existing object has no effect.

The handle of the object whose `CreateFcn` is being executed is accessible only through the root `CallbackObject` property, which you can query using `gcbo`.

For information on the syntax of callback functions, see [Function Handle Callbacks](#).

DeleteFcn

function handle | cell array containing function handle and additional arguments | string (not recommended)

Callback executed during object deletion. Executes when this object is deleted (for example, this might happen when you issue a `delete` command on the object, its parent axes, or the figure containing it). MATLAB executes the callback before destroying the object's properties so the callback routine can query these values. The default is an empty array.

The handle of the object whose `DeleteFcn` is being executed is accessible only through the root `CallbackObject` property, which can be queried using `gcbo`.

For information on the syntax of callback functions, see [Function Handle Callbacks](#).

See the `BeingDeleted` property for related information.

DisplayName

string

String used by legend. The `legend` function uses the `DisplayName` property to label the contourgroup object in the legend. The default is an empty string.

- If you specify string arguments with the `legend` function, MATLAB set `DisplayName` to the corresponding string and uses that string for the legend.
- If `DisplayName` is empty, `legend` creates a string of the form, `['data' n]`, where `n` is the number assigned to the object based on its location in the list of legend entries. However, `legend` does not set `DisplayName` to this string.

Contourgroup Properties

- If you edit the string directly in an existing legend, MATLAB set `DisplayName` to the edited string.
- If you specify a string for the `DisplayName` property and create the legend using the figure toolbar, then MATLAB uses the string defined by `DisplayName`.
- To add a legend programmatically that uses the `DisplayName` string, call `legend` with the `toggle` or `show` option.

See “Control Legend Content” for more information and examples.

EraseMode

{normal} | none | xor | background

Erase mode. Controls the technique MATLAB uses to draw and erase objects. Use alternative erase modes for creating animated sequences, where control of the way individual objects are redrawn is necessary to improve performance and obtain the desired effect.

- `normal` — Redraw the affected region of the display, performing the three-dimensional analysis necessary to correctly render all objects. This mode produces the most accurate picture, but is the slowest. The other modes are faster, but do not perform a complete redraw and are therefore less accurate.
- `none` — Do not erase the object when it is moved or destroyed. While the object is still visible on the screen after erasing with `EraseMode none`, you cannot print it because MATLAB stores no information about its former location.
- `xor` — Draw and erase the object by performing an exclusive OR (XOR) with the color of the screen beneath it. This mode does not damage the color of the objects beneath it. However, the object’s color depends on the color of whatever is beneath it on the display.
- `background` — Erase the object by redrawing it in the axes background `Color`, or the figure background `Color` if the axes

Color property is none. This damages objects that are behind the erased object, but properly colors the erased object.

Set the axes background color with the axes Color property. Set the figure background color with the figure Color property.

Printing with Nonnormal Erase Modes

MATLAB always prints figures as if the EraseMode of all objects is normal. This means graphics objects created with EraseMode set to none, xor, or background can look different on screen than on paper. On screen, MATLAB mathematically combines layers of colors (for example, performing an XOR on a pixel color with that of the pixel behind it) and ignore three-dimensional sorting to obtain greater rendering speed. However, these techniques are not applied to the printed output.

You can use the getframe command or other screen capture applications to create an image of a figure containing nonnormal mode objects.

Fill

{off} | on

Color spaces between contour lines.

- on — Default when using contourf or ezcontourf.
- off — Default when using contour or ezcontour.

By default, contour draws only the contour lines of the surface. If you set Fill to on, contour colors the regions in between the contour lines according to the Z-value of the region and changes the contour lines to black.

HandleVisibility

{on} | callback | off

Contourgroup Properties

Control access to object's handle. Determines when an object's handle is visible in its parent's list of children. `HandleVisibility` is useful for preventing command-line users from accidentally accessing objects that you need to protect for some reason.

- `on` — Handles are always visible.
- `callback` — Handles are visible from within callback routines or functions invoked by callback routines, but not from within functions invoked from the command line. This provides a means to protect GUIs from command-line users, while allowing callback routines to have access to object handles.
- `off` — Handles are invisible at all times. Use this option when a callback invokes a function that could damage the GUI (such as evaluating a user-typed string). This option temporarily hides its own handles during the execution of that function.

Functions Affected by Handle Visibility

When a handle is not visible in its parent's list of children, it cannot be returned by functions that obtain handles by searching the object hierarchy or querying handle properties. This includes `get`, `findobj`, `gca`, `gcf`, `gco`, `newplot`, `cla`, `clf`, and `close`.

Properties Affected by Handle Visibility

When a handle's visibility is restricted using `callback` or `off`, the object's handle does not appear in its parent's `Children` property, figures do not appear in the root's `CurrentFigure` property, objects do not appear in the root's `CallbackObject` property or in the figure's `CurrentObject` property, and axes do not appear in their parent's `CurrentAxes` property.

Overriding Handle Visibility

You can set the root `ShowHiddenHandles` property to `on` to make all handles visible regardless of their `HandleVisibility`

settings. This does not affect the values of the `HandleVisibility` properties. See also `findall`.

Handle Validity

Hidden handles are still valid. If you know an object's handle, you can `set` and `get` its properties and pass it to any function that operates on handles.

Note If you change one data source property to a variable that contains data of a different dimension, you might cause the function to generate a warning and not render the graph until you have changed all data source properties to appropriate values.

HitTest

{on} | off

Selectable by mouse click. Determines whether this object can become the current object (as returned by the `gco` command and the figure `CurrentObject` property) as a result of a mouse click on the line objects that compose the contour plot. If `HitTest` is `off`, clicking this object selects the object below it (which is usually the axes containing it).

HitTestArea

on | {off}

Select the object by clicking lines or area of extent. Select plot objects by:

- Clicking contour lines(default).
- Clicking anywhere in the extent of the plot.

When `HitTestArea` is `off`, you must click the contour lines (excluding the baseline) to select the object. When `HitTestArea`

Contourgroup Properties

is on, you can select this object by clicking anywhere within the extent of the plot (that is, anywhere within a rectangle that encloses all the contour lines).

Interruptible
off | {on}

Callback routine interruption

Controls whether MATLAB can interrupt an object's callback function when subsequent callbacks attempt to interrupt it.

For Graphics objects, the `Interruptible` property affects only the callbacks for the `ButtonDownFcn` property. A *running* callback is the currently executing callback. The *interrupting* callback is the callback that tries to interrupt the *running* callback. MATLAB handles both the callbacks based on the `Interruptible` property of the object of the *running* callback.

When the `Interruptible` property is set to:

- 'off', MATLAB finishes execution of the *running* callback without any interruptions
- 'on', these conditions apply:
 - If there is a `drawnow`, `figure`, `getframe`, `waitfor`, or `pause` command in the *running* callback, then MATLAB executes the *interrupting* callbacks which are already in the queue and returns to finish execution of the current callback.
 - If one of the above functions is not in the *running* callback, then MATLAB finishes execution of the current callback without any interruption.

`BusyAction` property of the object of interrupting callback determines whether the callback should be ignored or should be put in the queue.

Setting `Interruptible` property to on (default), allows a callback from other graphics objects to interrupt callback functions originating from this object.

Note MATLAB does not save the state of properties or the display when an interruption occurs. For example, the handle returned by the `gca` or `gcf` command may be changed as another callback is executed.

After the function that interrupts a callback completes, the callback resumes execution where it halted when interrupted. For more information, see “Control Callback Execution and Interruption”.

`LabelSpacing`

distance in points (default = 144)

Spacing between labels on each contour line. When you display contour line labels using either the `ShowText` property or the `clabel` command, the labels are spaced 144 points (2 inches) apart on each line. You can specify the spacing by setting the `LabelSpacing` property to a value in points. If the length of an individual contour line is less than the specified value, MATLAB displays only one contour label on that line.

`LevelList`

vector of `ZData`-values

Values at which contour lines are drawn. When the `LevelListMode` property is `auto`, the contour function automatically chooses contour values that span the range of values in `ZData` (the input argument `Z`). You can set this property to the values at which you want contour lines drawn.

To specify the contour interval (space between contour lines) use the `LevelStep` property.

Contourgroup Properties

LevelListMode
{auto} | manual

User-specified or autogenerated LevelList values. By default, the contour function automatically generates the values at which contours are drawn. If you set this property to `manual`, contour does not change the values in `LevelList` as you change the values of `ZData`.

LevelStep
scalar

Spacing of contour lines. The contour function draws contour lines at regular intervals determined by the value of `LevelStep`. When the `LevelStepMode` property is `auto`, contour determines the contour interval automatically based on the `ZData`.

LevelStepMode
{auto} | manual

User-specified or autogenerated LevelStep values. By default, the contour function automatically determines a value for the `LevelStep` property. If you set this property to `manual`, contour does not change the value of `LevelStep` as you change the values of `ZData`.

LineColor
{auto} | ColorSpec | none

Color of the contour lines. This property determines how MATLAB colors the contour lines.

- `auto` — Each contour line is a single color determined by its contour value, the figure colormap, and the color axis (`caxis`).
- `ColorSpec` — A three-element RGB vector or one of the MATLAB predefined names, specifying a single color for edges. The default value is `[0 0 0]` (black). See `ColorSpec` for more information on specifying color.

- none — No contour lines are drawn.

LineStyle

{-} | -- | : | -. | none

Line style of contourgroup object.

Line Style Specifiers Table

Specifier	Line Style
'-'	Solid line (default)
'--'	Dashed line
':'	Dotted line
'-.'	Dash-dot line
'none'	No line

LineWidth

size in points

Width of linear objects and edges of filled areas. Specify in points. 1 point = $1/72$ inch. The default is 0.5 points.

Parent

handle of parent axes, hggroup, or hgtransform

Parent of object. Handle of the object's parent. The parent is normally the axes, hggroup, or hgtransform object that contains the object.

Selected

on | {off}

Object selection state. When you set this property to on, MATLAB displays selection handles at the corners and midpoints if the SelectionHighlight property is also on (the default). You can, for example, define the ButtonDownFcn callback to set this

Contourgroup Properties

property to on, thereby indicating that this particular object is selected. This property is also set to on when an object is manually selected in plot edit mode.

SelectionHighlight
{on} | off

Object highlighted when selected.

- on — MATLAB indicates the selected state by drawing four edge handles and four corner handles.
- off — MATLAB does not draw the handles except when in plot edit mode and objects are selected manually.

ShowText
on | {off}

Display labels on contour lines. When you set this property to on, MATLAB displays text labels on each contour line indicating the contour value. See also `LevelList`, `clabel`, and the example “Display Contour Labels” on page 1-1106.

Tag
string

User-specified object label. Provides a means to identify graphics objects with a user-specified label. The default is an empty string.

Use the `Tag` property and the `findobj` function to manipulate specific objects within a plotting hierarchy.

For example, create an `areaseries` object and set the `Tag` property.

```
t = area(Y, 'Tag', 'area1')
```

When you want to access objects of a given type, use `findobj` to find the object’s handle. The following statement changes the `FaceColor` property of the object whose `Tag` is `area1`.

```
set(findobj('Tag','area1'),'FaceColor','red')
```

TextList
vector

Contour values to label. This property contains the contour values where text labels are placed. By default, these values are the same as those contained in the `LevelList` property, which define where the contour lines are drawn. Note that there must be an equivalent contour line to display a text label.

For example, the following statements create and label a contour plot:

```
[c,h]=contour(peaks);  
clabel(c,h)
```

You can get the `LevelList` property to see the contour line values:

```
get(h,'LevelList')
```

Suppose you want to view the contour value 4.375 instead of the value of 4 that the contour function used. To do this, you need to set both the `LevelList` and `TextList` properties:

```
set(h,'LevelList',[-6 -4 -2 0 2 4.375 6 8],...  
    'TextList',[-6 -4 -2 0 2 4.375 6 8])
```

TextListMode
{auto} | manual

User-specified or auto TextList values. When this property is `auto`, MATLAB sets the `TextList` property equal to the values of the `LevelList` property (i.e., a text label for each contour line). When this property is `manual`, MATLAB does not set the values of the `TextList` property. Note that specifying values for the `TextList` property causes the `TextListMode` property to be set to `manual`.

Contourgroup Properties

TextStep
scalar

Determines which contour line have numeric labels. The contour function labels contour lines at regular intervals which are determined by the value of the TextStep property. When the TextStepMode property is auto, contour labels every contour line when the ShowText property is on.

TextStepMode
{auto} | manual

User-specified or autogenerated TextStep values. By default, the contour function automatically determines a value for the TextStep property. If you set this property to manual, contour does not change the value of TextStep as you change the values of ZData.

Type
string (read-only)

Type of graphics object. String that identifies the class of the graphics object. Use this property to find all objects of a given type within a plotting hierarchy. For contourgroup objects, Type is 'hggroup'. This statement finds all the hggroup objects in the current axes.

```
t = findobj(gca, 'Type', 'hggroup');
```

UIContextMenu
handle of uicontextmenu object

Associate context menu with object. Handle of a uicontextmenu object created in the object's parent figure. Use the uicontextmenu function to create the context menu. MATLAB displays the context menu whenever you right-click over the object. The default value is an empty array.

UserData

array

User-specified data. Data you want to associate with this object (including cell arrays and structures). The default value is an empty array. MATLAB does not use this data, but you can access it using the `set` and `get` commands.

Visible

{on} | off

Visibility of object and its children.

- **on** — Object and all children of the object are visible unless the child object's `Visible` property is `off`.
- **off** — Object not displayed. However, the object still exists and you can set and query its properties.

XData

vector | matrix

x-axis values for graph. The *x*-axis values for graphs are specified by the `X` input argument. If `XData` is a vector, `length(XData)` must equal `length(YData)` and must be monotonic. If `XData` is a matrix, `size(XData)` must equal `size(YData)` and each column must be monotonic.

You can use `XData` to define meaningful coordinates for an underlying surface whose topography is being mapped.

XDataMode

{auto} | manual

Use automatic or user-specified x-axis values. If you specify `XData` (by setting the `XData` property or specifying the `X` input argument), MATLAB sets this property to `manual` and uses the specified values to label the *x*-axis.

Contourgroup Properties

If you set `XDataMode` to `auto` after having specified `XData`, MATLAB resets the *x*-axis ticks to the column indices of the `ZData`, overwriting any previous values for `XData`.

`XDataSource`

MATLAB variable, as a string

Link XData to MATLAB variable. Set this property to a MATLAB variable that is evaluated in the base workspace to generate the `XData`. The default value is an empty array.

```
set(h, 'XDataSource', 'xdatavariablename')
```

MATLAB requires a call to `refreshdata` when you set this property. Changing workspace variables used as an object's `XDataSource` does not change the object's `XData` values, but you can use `refreshdata` to force an update of the object's data. `refreshdata` also lets you specify that the data source variable be evaluated in the workspace of a function from which you call `refreshdata`.

Note If you change one data source property to a variable that contains data of a different dimension, you might cause the function to generate a warning and not render the graph until you have changed all data source properties to appropriate values.

`YData`

scalar | vector | matrix

Y-axis limits. This property determines the *y*-axis limits used in the contour plot. If you do not specify a `Y` argument, the `contour` function calculates *y*-axis limits based on the size of the input argument `Z`.

`YData` can be either a matrix equal in size to `ZData` or a vector equal in length to the number of columns in `ZData`.

Use `YData` to define meaningful coordinates for the underlying surface whose topography is being mapped.

`YDataMode`
{auto} | manual

Use automatic or user-specified y-axis values. In auto mode (the default) the contour function automatically determines the *y*-axis limits. If you set this property to manual, specify a value for `YData`, or specify a *Y* argument, then contour sets this property to manual and does not change the axis limits.

If you set `YDataMode` to auto after having specified `YData`, MATLAB resets the *y*-axis ticks to the row indices of the `ZData`, overwriting any previous values for `YData`.

`YDataSource`
MATLAB variable, as a string

Link YData to MATLAB variable. Set this property to a MATLAB variable that is evaluated in the base workspace to generate the `YData`. The default value is an empty array.

```
set(h, 'YDataSource', 'Ydatavariablename')
```

MATLAB requires a call to `refreshdata` when you set this property. Changing workspace variables used as an object's `YDataSource` does not change the object's `YData` values, but you can use `refreshdata` to force an update of the object's data. `refreshdata` also lets you specify that the data source variable be evaluated in the workspace of a function from which you call `refreshdata`.

Contourgroup Properties

Note If you change one data source property to a variable that contains data of a different dimension, you might cause the function to generate a warning and not render the graph until you have changed all data source properties to appropriate values.

ZData

matrix

Contour data. This property contains the data from which the contour lines are generated (specified as the input argument `Z`). `ZData` must be at least a 2-by-2 matrix. The number of contour levels and the values of the contour levels are chosen automatically based on the minimum and maximum values of `ZData`. The limits of the x - and y -axis are `[1:n]` and `[1:m]`, where `[m,n] = size(ZData)`.

ZDataSource

MATLAB variable, as a string

Link ZData to MATLAB variable. Set this property to a MATLAB variable that is evaluated in the base workspace to generate the `ZData`. The default value is an empty array.

```
set(h, 'ZDataSource', 'zdatavariablename')
```

MATLAB requires a call to `refreshdata` when you set this property. Changing workspace variables used as an object's `ZDataSource` does not change the object's `ZData` values, but you can use `refreshdata` to force an update of the object's data. `refreshdata` also lets you specify that the data source variable be evaluated in the workspace of a function from which you call `refreshdata`.

Note If you change one data source property to a variable that contains data of a different dimension, you might cause the function to generate a warning and not render the graph until you have changed all data source properties to appropriate values.

How To

- “Core Graphics Objects”
- “Setting Default Property Values”
- “Customize Objects in Graph”

contourslice

Purpose Draw contours in volume slice planes



Syntax

```
contourslice(X,Y,Z,V,Sx,Sy,Sz)
contourslice(X,Y,Z,V,Xi,Yi,Zi)
contourslice(V,Sx,Sy,Sz)
contourslice(V,Xi,Yi,Zi)
contourslice(...,n)
contourslice(...,cvals)
contourslice(...,[cv cv])
contourslice(...,'method')
contourslice(axes_handle,...)
h = contourslice(...)
```

Description `contourslice(X,Y,Z,V,Sx,Sy,Sz)` draws contours in the x -, y -, and z -axis aligned planes at the points in the vectors Sx , Sy , Sz . The arrays X , Y , and Z define the coordinates for the volume V and must be monotonic and represent a Cartesian, axis-aligned grid (such as the data produced by `meshgrid`). The color at each contour is determined by the volume V , which must be an m -by- n -by- p volume array.

`contourslice(X,Y,Z,V,Xi,Yi,Zi)` draws contours through the volume V along the surface defined by the 2-D arrays Xi , Yi , Zi . The surface should lie within the bounds of the volume.

`contourslice(V,Sx,Sy,Sz)` and `contourslice(V,Xi,Yi,Zi)` (omitting the X , Y , and Z arguments) assume $[X,Y,Z] = \text{meshgrid}(1:n,1:m,1:p)$, where $[m,n,p] = \text{size}(v)$.

`contourslice(...,n)` draws n contour lines per plane, overriding the automatic value.

`contourslice(...,cvals)` draws `length(cval)` contour lines per plane at the values specified in vector `cvals`.

`contourslice(...,[cv cv])` computes a single contour per plane at the level `cv`.

`contourslice(..., 'method')` specifies the interpolation method to use. *method* can be `linear`, `cubic`, or `nearest`. `nearest` is the default except when the contours are being drawn along the surface defined by X_i, Y_i, Z_i , in which case `linear` is the default. (See `interp3` for a discussion of these interpolation methods.)

`contourslice(axes_handle, ...)` plots into the axes with the handle `axes_handle` instead of into the current axes (`gca`).

`h = contourslice(...)` returns a vector of handles to patch objects that are used to implement the contour lines.

Examples

Contour Slices of Fluid Flow

Store the matrices X, Y, Z , and V from the flow data set.

```
[X,Y,Z,V] = flow;
```

Create nine contour plots in the y - z plane, no plots in the x - z plane, and one plot in the x - y plane by specifying S_x as a vector of nine elements, S_y as an empty vector, and S_z as a scalar.

```
Sx = 1:9;  
Sy = [];  
Sz = 0;
```

Draw 10 contour lines between -8 and 2 by specifying `cvals` as a 10-element vector of linearly spaced values between -8 and 2.

```
cvals = linspace(-8,2,10);
```

Create the contour slice plots and set the axis limits. Set the data aspect ratio, change the camera position, and display the black box outline.

```
figure  
contourslice(X,Y,Z,V,Sx,Sy,Sz,cvals);  
  
axis([0,10,-3,3,-3,3]);  
daspect([1,1,1]);
```

contourslice

```
campos([0, -20, 7]);  
box on
```

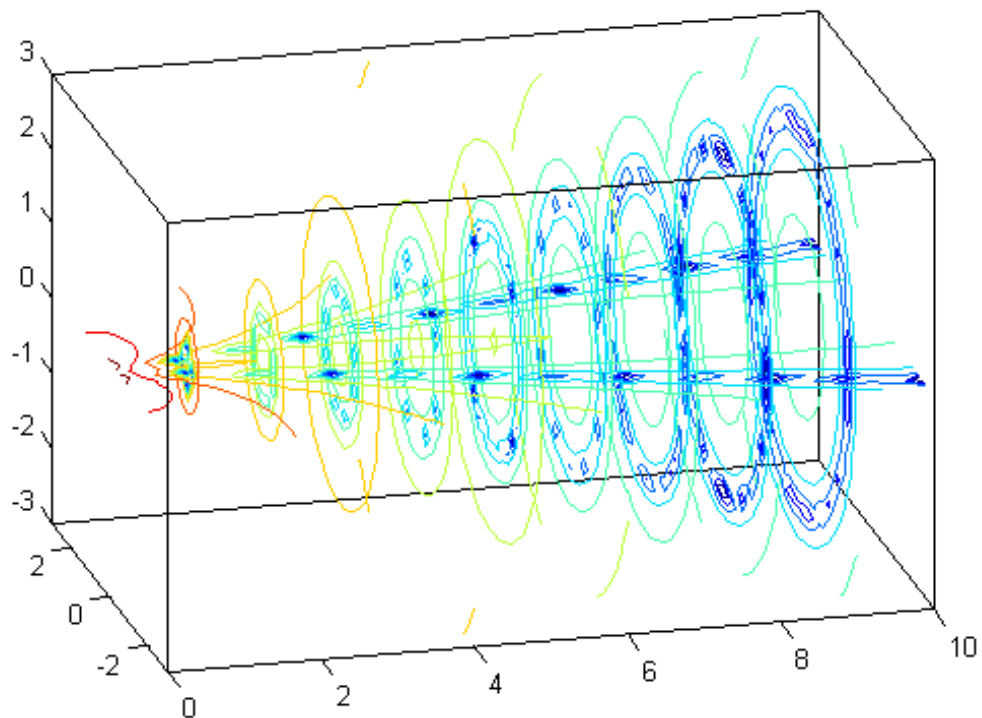

Contour Slices Along Spherical Surface

Set up matrices X, Y, and Z using the meshgrid function.

```
x = -2:0.2:2;  
y = -2:0.25:2;  
z = -2:0.16:2;
```



```
[X,Y,Z] = meshgrid(x,y,z);
```

Use X, Y, and Z to define V as a matrix of volume data.

```
V = X.*exp(-X.^2-Y.^2-Z.^2);
```

Return matrices Xi, Yi, and Zi from the sphere function.

```
[Xi,Yi,Zi] = sphere;
```

Draw contours through the volume V along the surface defined by Xi, Yi, and Zi. Change the plot view to a 3-D view.

```
contourslice(X,Y,Z,V,Xi,Yi,Zi)  
view(3)
```

contourslice

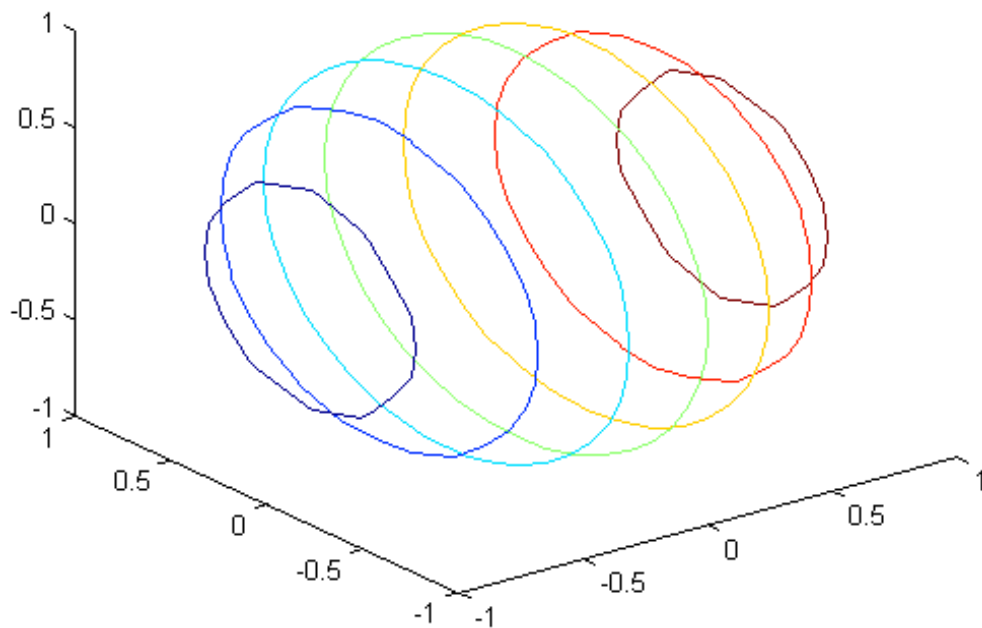

See Also

[isosurface](#) | [slice](#) | [smooth3](#) | [subvolume](#) | [reducevolume](#)

Purpose

Summary of classes in MATLAB Constraints Interface

Description

Constraints specify business rules against which to qualify a calculated value. Use constraints in conjunction with the `matlab.unittest.qualifications` qualification methods `assertThat`, `assumeThat`, `fatalAssertThat`, or `verifyThat`. Constraints determine whether or not a calculated (actual) value satisfies the constraint. Constraints also provide diagnostics. The `matlab.unittest.constraints` package consists of the following classes.

- “Constraint Implementations” on page 1-1145
- “Actual Value Proxies” on page 1-1148
- “Tolerances” on page 1-1148
- “Comparators” on page 1-1148

Constraint Implementations

Fundamental Constraint-Related Interfaces

`matlab.unittest.constraints.BooleanConstraint` Interface class for boolean combinations of constraints

`matlab.unittest.constraints.Constraint` Fundamental interface class for comparisons

General Purpose

`matlab.unittest.constraints.EventuallySatisfies` Constraint for value to asynchronously satisfy constraint

`matlab.unittest.constraints.HasField` Constraint specifying structure containing particular field

`matlab.unittest.constraints.IsAnything` Constraint specifying any value

`matlab.unittest.constraints.IsEqualTo` General constraint to compare for equality

`matlab.unittest.constraints.IsFalse` Constraint specifying false value

matlab.unittest.constraints.IsSameHandleAs **Constraint** specifying handle instance same as another

matlab.unittest.constraints.IsTrue **Constraint** specifying true value

matlab.unittest.constraints>ReturnsConstraint **Constraint** specifying function handle that returns true

Errors and Warnings

matlab.unittest.constraints.IssuesNoWarnings **Constraint** specifying function that issues no warnings

matlab.unittest.constraints.IssuesWarning **Constraint** specifying function that issues expected warning profile

matlab.unittest.constraints.Throws **Constraint** specifying function handle that throws MException

Inequalities

matlab.unittest.constraints.IsGreaterThan **Constraint** specifying value greater than another value

matlab.unittest.constraints.IsGreaterThanOrEqualTo **Constraint** specifying value greater than or equal to another value

matlab.unittest.constraints.IsLessThan **Constraint** specifying value less than another value

matlab.unittest.constraints.IsLessThanOrEqualTo **Constraint** specifying value less than or equal to another value

Array Size

matlab.unittest.constraints.HasElementCount **Constraint** specifying expected number of elements

matlab.unittest.constraints.HasLength **Constraint** specifying expected length of array

matlab.unittest.constraints.HasSizeConstraint specifying expected size of array

matlab.unittest.constraints.IsEmptyConstraint specifying empty value

Type

matlab.unittest.constraints.IsInstanceOfConstraint specifying inclusion in given class hierarchy

matlab.unittest.constraints.IsOfClassConstraint specifying class type

Strings

matlab.unittest.constraints.ContainsSubstringConstraint specifying string containing substring

matlab.unittest.constraints.EndsWithSubstringConstraint specifying string ending with substring

matlab.unittest.constraints.IsSubStringOfConstraint specifying substring of another string

matlab.unittest.constraints.MatchesConstraint specifying string matches regular expression

matlab.unittest.constraints.StartsWithSubstringConstraint specifying string starting with substring

Finiteness

matlab.unittest.constraints.HasInfConstraint specifying array containing any infinite value

matlab.unittest.constraints.HasNaNConstraint specifying array containing NaN value

matlab.unittest.constraints.IsFiniteConstraint specifying finite value

Numeric Attributes

matlab.unittest.constraints.IsReal Constraint specifying real valued array

matlab.unittest.constraints.IsSparse Constraint specifying sparse array

Actual Value Proxies

matlab.unittest.constraints.AnyCellTest If any element of cell array meets constraint

matlab.unittest.constraints.AnyElementTest If any element of array meets constraint

matlab.unittest.constraints.EveryCellTest If all elements of cell array meet constraint

matlab.unittest.constraints.EveryElementTest If all elements of array meet constraint

Tolerances

matlab.unittest.constraints.AbsoluteTolerance Absolute numeric tolerance

matlab.unittest.constraints.RelativeTolerance Relative numeric tolerance

matlab.unittest.constraints.Tolerance Abstract interface class for tolerances

Comparators

matlab.unittest.constraints.CellComparator Comparator for cell arrays

matlab.unittest.constraints.LogicalComparator Comparator for two logical values

matlab.unittest.constraints.NumericComparator Comparator for numeric data types

matlab.unittest.constraints.ObjectComparator for MATLAB or Java objects

matlab.unittest.constraints.PublicPropertyComparator for public properties of MATLAB objects

matlab.unittest.constraints.StringComparator for two strings

matlab.unittest.constraints.StructComparator for MATLAB structure arrays

matlab.unittest.constraints.AbsoluteTolerance

Superclasses Tolerance

Purpose Absolute numeric tolerance

Description This numeric Tolerance assesses the magnitude of the difference between actual and expected values. For the tolerance to be satisfied, `abs(expVal - actVal) <= absTol` must be true.

Construction `AbsoluteTolerance(tolVals)` creates an absolute tolerance object that assesses the magnitude of the difference between the actual and expected values.

The data types of the inputs to the `AbsoluteTolerance` constructor determine the data types to which the tolerance is applied.

For example, `AbsoluteTolerance(10*eps)` constructs an `AbsoluteTolerance` for comparing double-precision numeric arrays while `AbsoluteTolerance(int8(2))` constructs an `AbsoluteTolerance` for comparing numeric arrays of type `int8`. If the actual and expected values being compared contain more than one numeric data type, the tolerance only applies to the data types specified by the values passed into the constructor.

Different tolerance values can be specified for different data types by passing multiple tolerance values to the constructor. For example, `AbsoluteTolerance(10*eps, 10*eps('single'), int8(1))` constructs an `AbsoluteTolerance` that would apply the following absolute tolerances.

- `10*eps` applies an absolute tolerance of `10*eps` for double-precision numeric arrays.
- `10*eps('single')` applies an absolute tolerance of `10*eps` for single-precision numeric arrays.
- `int8(1)` applies an absolute tolerance of 1 for numeric arrays of type `int8`.

You can specify more than one tolerance for a particular data type by combining tolerances with the & and | operators. To combine two tolerances, the sizes of the tolerance values for each data type must be compatible.

Input Arguments

tolVals

Numeric tolerances, specified as a cell array of numeric arrays. Each input argument contains the tolerance specification for a particular data type. Each numeric array can be a scalar or array with the same number of dimensions as the actual and expected values.

Properties

Values

Numeric tolerances, specified by the tolVals input argument.

Methods

and	Form logical element-wise conjunction of tolerances
or	Form logical element-wise disjunction of tolerances

Copy Semantics

Value. To learn how value classes affect copy operations, see Copying Objects in the MATLAB documentation.

Examples

Test with Absolute Tolerance

Create a test case for interactive testing.

```
import matlab.unittest.TestCase;  
import matlab.unittest.constraints.IsEqualTo;  
import matlab.unittest.constraints.AbsoluteTolerance;
```

```
testCase = TestCase.forInteractiveUse;
```

matlab.unittest.constraints.AbsoluteTolerance

Assert that the difference between and actual value, 4.1, and an expected value, 4.5, is less than 0.5.

```
testCase.assertThat(4.1, IsEqualTo(4.5, ...  
    'Within', AbsoluteTolerance(0.5)));
```

Interactive assertion passed.

Specify Absolute Tolerance for Different Data Types

Create a test case for interactive testing.

```
import matlab.unittest.TestCase;  
import matlab.unittest.constraints.IsEqualTo;  
import matlab.unittest.constraints.AbsoluteTolerance;
```

```
testCase = TestCase.forInteractiveUse;
```

Create the following actual and expected cell arrays.

```
act = {'abc', 123, single(106), int8([1, 2, 3])};  
exp = {'abc', 122, single(105), int8([2, 4, 6])};
```

Test whether the arrays satisfy the `AbsoluteTolerance` constraint within a value of 2.

```
testCase.verifyThat(act, IsEqualTo(exp, ...  
    'Within', AbsoluteTolerance(2)));
```

Interactive verification failed.

```
-----  
Framework Diagnostic:  
-----
```

```
IsEqualTo failed.
```

```
--> NumericComparator failed.
```

```
    Path to failure: <Value>{3}
```

```
    --> The values are not equal using "isequaln".
```

```
    --> The tolerance does not support single values so it was not used.
```

```
Actual Value:
    106
Expected Value:
    105
```

```
Actual cell:
    'abc'    [123]    [106]    [1x3 int8]
Expected cell:
    'abc'    [122]    [105]    [1x3 int8]
```

The test fails because the tolerance is only applied to the double data type.

Create a tolerance object that specifies different tolerances for different data types.

```
tolObj = AbsoluteTolerance(2, single(3), int8([2, 3, 5]));
```

A tolerance of 2 is applied to double valued data. A tolerance of 3 is applied to single valued data. A tolerance of [2 3 5] is applied to corresponding array elements of int8 valued data.

Verify that the expected and actual values satisfy the `AbsoluteTolerance` constraint.

```
testCase.verifyThat(act, IsEqualTo(exp, 'Within', tolObj));
```

```
Interactive verification passed.
```

Combine Absolute and Relative Tolerances

Create a test case for interactive testing.

```
import matlab.unittest.TestCase;
import matlab.unittest.constraints.IsEqualTo;
import matlab.unittest.constraints.AbsoluteTolerance;
import matlab.unittest.constraints.RelativeTolerance;
```

matlab.unittest.constraints.AbsoluteTolerance

```
testCase = TestCase.forInteractiveUse;
```

Define an actual value approximation for pi.

```
act = 3.14;
```

Construct a tolerance object to test that difference between the actual and expected values is within 0.001 and within 0.25%.

```
tolObj = AbsoluteTolerance(0.001) & RelativeTolerance(0.0025);
```

Verify that the actual value is within the tolerance of the expected value of pi.

```
testCase.verifyThat(act, IsEqualTo(pi, 'Within', tolObj));
```

```
Interactive verification failed.
```

```
-----  
Framework Diagnostic:  
-----
```

```
IsEqualTo failed.
```

```
--> NumericComparator failed.
```

```
    --> The values are not equal using "isequaln".
```

```
    --> AndTolerance failed.
```

```
        --> AbsoluteTolerance failed.
```

```
            --> The value was not within absolute tolerance.
```

```
                Tolerance Value:
```

```
                    1.0000000000000000e-03
```

```
            --> RelativeTolerance passed.
```

```
Actual Value:
```

```
    3.1400000000000000
```

```
Expected Value:
```

```
    3.141592653589793
```

The actual value does not satisfy the `AbsoluteTolerance` constraint.

Construct a constraint that is satisfied if the values are within 0.001 or 0.25%, and retest the actual value.

```
tolObj = AbsoluteTolerance(0.001) | RelativeTolerance(0.0025);  
testCase.verifyThat(act, IsEqualTo(pi, 'Within', tolObj));
```

Interactive verification passed.

Combine Absolute and Relative Tolerances to Test Small and Large Values

Typically when testing equality of values, an absolute (floor) tolerance dominates when the values are near zero, and a relative tolerance dominates for larger values.

Create a test case for interactive testing.

```
import matlab.unittest.TestCase;  
import matlab.unittest.constraints.IsEqualTo;  
import matlab.unittest.constraints.AbsoluteTolerance;  
import matlab.unittest.constraints.RelativeTolerance;
```

```
testCase = TestCase.forInteractiveUse;
```

Define two structures containing electromagnetic properties of a vacuum. One structure, `approxVacuumProps`, contains approximate values for the permeability and speed of light in a vacuum.

```
approxVacuumProps.Permeability = 1.2566e-06; % Approximate  
approxVacuumProps.Permittivity = 8.854187817*10^-12;  
approxVacuumProps.LightSpeed = 2.9979e+08; % Approximate
```

```
baselineVacuumProps.Permeability = 4*pi*10^-7;  
baselineVacuumProps.Permittivity = 8.854187817*10^-12;  
baselineVacuumProps.LightSpeed = 1/sqrt(...  
    baselineVacuumProps.Permeability*baselineVacuumProps.Permittivity);
```

Test that the relative difference between the approximate and baseline values is within `eps*1e11`.

matlab.unittest.constraints.AbsoluteTolerance

```
testCase.verifyThat(approxVacuumProps, IsEqualTo(baselineVacuumProps, ...
    'Within', RelativeTolerance(eps*1e11)));
```

Interactive verification failed.

```
-----  
Framework Diagnostic:  
-----
```

IsEqualTo failed.

--> NumericComparator failed.

Path to failure: <Value>.Permeability

--> The values are not equal using "isequaln".

--> RelativeTolerance failed.

--> The value was not within relative tolerance.

Tolerance Value:

2.220446049250313e-05

Actual Value:

1.2566000000000000e-06

Expected Value:

1.256637061435917e-06

Actual struct:

Permeability: 1.2566000000000000e-06

Permittivity: 8.854187816999999e-12

LightSpeed: 299790000

Expected struct:

Permeability: 1.256637061435917e-06

Permittivity: 8.854187816999999e-12

LightSpeed: 2.997924580105029e+08

The test fails because the relative difference in the permeabilities is not within the tolerance. The difference between the two values is small, but the numbers are close to zero, so the difference relative to their size isn't small enough to satisfy the tolerance.

matlab.unittest.constraints.AbsoluteTolerance

Construct a tolerance object to test that the absolute difference between the approximate and baseline values is within $1e-4$.

```
testCase.verifyThat(approxVacuumProps, IsEqualTo(baselineVacuumProps,
    'Within', AbsoluteTolerance(1e-4)));
```

Interactive verification failed.

```
-----  
Framework Diagnostic:  
-----
```

IsEqualTo failed.

```
--> NumericComparator failed.
```

```
    Path to failure: <Value>.LightSpeed
```

```
    --> The values are not equal using "isequaln".
```

```
    --> AbsoluteTolerance failed.
```

```
        --> The value was not within absolute tolerance.
```

```
            Tolerance Value:
```

```
                1.0000000000000000e-04
```

```
            Actual Value:
```

```
                299790000
```

```
            Expected Value:
```

```
                2.997924580105029e+08
```

```
Actual struct:
```

```
    Permeability: 1.2566000000000000e-06
```

```
    Permittivity: 8.8541878169999999e-12
```

```
    LightSpeed: 299790000
```

```
Expected struct:
```

```
    Permeability: 1.256637061435917e-06
```

```
    Permittivity: 8.8541878169999999e-12
```

```
    LightSpeed: 2.997924580105029e+08
```

matlab.unittest.constraints.AbsoluteTolerance

The test fails because the absolute difference in the speed of light is not within the tolerance. The difference between the two values is small relative to their size, but too large to satisfy the tolerance.

Construct a logical disjunction of tolerance objects to test that the absolute difference between the approximate and baseline values is within $1e-4$ or the relative difference is within $\text{eps} \cdot 1e11$. This tolerance is used so permeability values, which are close to zero, satisfy the absolute (floor) tolerance, and speed of light values, which are large, satisfy the relative tolerance.

```
testCase.verifyThat(approxVacuumProps, IsEqualTo(baselineVacuumProps, ...  
    'Within', RelativeTolerance(eps*1e11)| AbsoluteTolerance(1e-4)));
```

```
Interactive verification passed.
```

See Also

[matlab.unittest.constraints.RelativeTolerance](#) |
[matlab.unittest.constraints.IsEqualTo](#)

Concepts

matlab.unittest.constraints.AbsoluteTolerance.and

Purpose Form logical element-wise conjunction of tolerances

Syntax `outTo1Obj = and(to1Obj1, to1Obj2)`

Description `outTo1Obj = and(to1Obj1, to1Obj2)` forms the logical element-wise conjunction of tolerances and returns a single tolerance, `outTo1Obj`. This is a means to specify that every element of the actual value should be equal to the expected value to within the tolerance specified by both `to1Obj1` and `to1Obj2`. A qualification failure occurs when either `to1Obj1` or `to1Obj2` is not satisfied for one or more elements of the comparison values.

Typically, the `and` method is not called directly, but the `and` operator, `&`, is used to denote the conjunction of any two tolerance objects.

Input Arguments **to1Obj**
Tolerance instance

Examples **Form Logical and of Tolerances**

```
import matlab.unittest.TestCase;
import matlab.unittest.constraints.IsEqualTo;
import matlab.unittest.constraints.AbsoluteTolerance;
import matlab.unittest.constraints.RelativeTolerance;

% Create a TestCase for interactive use
testCase = TestCase.forInteractiveUse;

% Passing qualifications
testCase.verifyThat(101, IsEqualTo(100, 'Within', ...
    AbsoluteTolerance(2) & RelativeTolerance(0.02)));
testCase.verifyThat([101, 105], IsEqualTo([100, 100], 'Within', ...
    AbsoluteTolerance([2, 10]) & RelativeTolerance([0.02, 0.1])));

% Failing qualifications
testCase.verifyThat(101, IsEqualTo(100, 'Within', ...
```

matlab.unittest.constraints.AbsoluteTolerance.and

```
        AbsoluteTolerance(2) & RelativeTolerance(0.02));  
testCase.verifyThat([101, 105], IsEqualTo([100, 100], 'Within', ...  
        AbsoluteTolerance(2) & RelativeTolerance(0.02));
```

See Also or

Purpose Form logical element-wise disjunction of tolerances

Syntax `outTo1Obj = or(tolObj1,tolObj2)`

Description `outTo1Obj = or(tolObj1,tolObj2)` forms the logical element-wise disjunction of tolerances and returns a single tolerance, `outTo1Obj`. This is a means to specify that every element of the actual value should be equal to the expected value to within the tolerance specified by either `tolObj1` or `tolObj2`. A qualification failure occurs when both `tolObj1` and `tolObj2` are not satisfied for one or more elements of the comparison values.

Forming the logical disjunction of tolerances is particularly useful when relative tolerance is used in general, but absolute tolerance is used when values are small.

Typically, the `or` method is not called directly, but the `or` operator, `|`, is used to denote the disjunction of any two tolerance objects.

Input Arguments

tolObj
Tolerance instance

Examples

Form Logical or of Tolerances

```
import matlab.unittest.TestCase;
import matlab.unittest.constraints.IsEqualTo;
import matlab.unittest.constraints.AbsoluteTolerance;
import matlab.unittest.constraints.RelativeTolerance;
```

```
% Create a TestCase for interactive use
testCase = TestCase.forInteractiveUse;
```

```
% Simple passing qualification
testCase.verifyThat(105, IsEqualTo(100, 'Within', ...
    AbsoluteTolerance(3) | RelativeTolerance(0.1)));
```

```
% The following qualification passes because the or
```

```
% operation is performed element-wise between the
% actual and expected values being compared:
testCase.verifyThat([8, 104], IsEqualTo([10, 100], 'Within', ...
    AbsoluteTolerance(3) | RelativeTolerance(0.05)));
% Note that the following would fail:
testCase.verifyThat([8, 104], ...
    IsEqualTo([10, 100], 'Within', AbsoluteTolerance(3)) | ...
    IsEqualTo([10, 100], 'Within', RelativeTolerance(0.05)));

% Failing qualifications
testCase.verifyThat(101, IsEqualTo(100, 'Within', ...
    AbsoluteTolerance(0.5) | RelativeTolerance(0)));
testCase.verifyThat([101, 101], IsEqualTo([100, 100], 'Within', ...
    AbsoluteTolerance([2, 0.5]) | RelativeTolerance([0.02, 0.001])));
```

See Also and

Purpose	Test if any element of cell array meets constraint
Description	<p>The AnyCellOf class creates a proxy of the actual value to the framework. The proxy enables a test writer to apply a constraint against each element of a cell array, which ensures that a passing result occurs if at least one element of the cell array satisfies the constraint.</p> <p>It is intended that you use this class through <code>matlab.unittest</code> qualifications as shown in the examples. The class does not modify the provided actual value, but serves as a wrapper to perform the constraint analysis. The testing framework analyzes the constraint on an element-by-element basis.</p>
Construction	<p><code>AnyCellOf(actVal)</code> creates a proxy instance that tests if any element of a provided cell array, <code>actVal</code>, meets a constraint. The test passes if at least one element individually satisfies the constraint.</p>
	Input Arguments
	actVal Actual value to test against constraint
Properties	ActualValue Actual value to test against constraint. Set this property through the constructor via the <code>actVal</code> input argument.
Copy Semantics	Value. To learn how value classes affect copy operations, see Copying Objects in the MATLAB documentation.
Examples	Test That Any Cell Satisfies Constraint Create a test case for interactive testing. <pre>import matlab.unittest.TestCase import matlab.unittest.constraints.AnyCellOf;</pre>

matlab.unittest.constraints.AnyCellOf

```
testCase = TestCase.forInteractiveUse;
```

Test that at least one cell of actVal is finite.

```
import matlab.unittest.constraints.IsFinite;
actVal = {NaN, Inf, 5};
testCase.verifyThat(AnyCellOf(actVal), IsFinite);
```

Interactive verification passed.

Test that at least one cell of the actual value contains five elements.

```
import matlab.unittest.constraints.HasElementCount
testCase.verifyThat(AnyCellOf({42, [11 38], 1:5}), HasElementCount(5));
```

Interactive verification passed.

Test that at least one cell of the actual value matches the string 'tea' regardless of case.

```
import matlab.unittest.constraints.Matches
testCase.verifyThat(AnyCellOf({'Coffee', 'Tea', 'Water'}), ...
    Matches('tea', 'IgnoringCase', true));
```

Interactive verification passed.

Test that at least one cell of the actual value is less than zero.

```
import matlab.unittest.constraints.IsLessThan;
testCase.verifyThat(AnyCellOf({1, 5}), IsLessThan(0));
```

Interactive verification failed.

```
-----
Framework Diagnostic:
-----
```

All cells failed. The first cell failed because:

```
--> IsLessThan failed.
```

```
    --> The value must be less than the maximum value.
```

```
Actual Value:
    1
Maximum Value (Exclusive):
    0
```

```
Actual Value Cell Array:
    [1]    [5]
```

Neither actual value element is less than zero.

Test that neither cell of the actual value is empty.

```
import matlab.unittest.constraints.IsEmpty
testCase.verifyThat(AnyCellOf({inputParser.empty, ''}), ~IsEmpty)
```

Interactive verification failed.

```
-----
Framework Diagnostic:
-----
```

All cells failed. The first cell failed because:

```
--> Negated IsEmpty failed.
    --> The value must not be empty.
    --> The value has a size of [0 0].
```

```
Actual Value:
    0x0 inputParser array with properties:
```

```
    FunctionName
    CaseSensitive
    KeepUnmatched
    PartialMatching
    StructExpand
    Parameters
    Results
    Unmatched
    UsingDefaults
```

matlab.unittest.constraints.AnyCellOf

```
Actual Value Cell Array:  
[] ''
```

Both actual value elements are empty.

See Also

[matlab.unittest.qualifications | EveryElementOf | AnyElementOf](#)
[| EveryCellOf](#)

Concepts

Purpose

Test if any element of array meets constraint

Description

The `AnyElementOf` class creates a proxy of the actual value to the framework. The proxy enables a test writer to apply a constraint against each element of an array, which ensures that a passing result occurs when at least one element of the array satisfies the constraint.

It is intended that you use this class through `matlab.unittest` qualifications as shown in the examples. The class does not modify the provided actual value, but serves as a wrapper to perform the constraint analysis. The testing framework analyzes the constraint on an element-by-element basis.

Construction

`AnyElementOf(actVal)` creates a proxy instance that tests if any element of a provided array, `actVal`, meets a constraint. The test passes if at least one element individually satisfies the constraint.

Tips

- `AnyElementOf` checks if any element in the provided array satisfies an associated constraint. However, there are some constraints, such as `HasNaN` and `HasInf`, that natively validate if any of the elements satisfy a condition. In these situations, use of `AnyElementOf` is unnecessary and impedes qualification performance.

Input Arguments

`actVal`

Actual value to test against constraint

Properties

`ActualValue`

Actual value to test against constraint. Set this property through the constructor via the `actVal` input argument.

Copy Semantics

Value. To learn how value classes affect copy operations, see [Copying Objects](#) in the MATLAB documentation.

Examples

Test That Any Element Satisfies Constraint

Create a test case for interactive testing.

```
import matlab.unittest.TestCase
import matlab.unittest.constraints.AnyElementOf;
```

```
testCase = TestCase.forInteractiveUse;
```

Test that at least one element of actVal is finite.

```
import matlab.unittest.constraints.IsFinite;
actVal = [NaN, Inf, 5];
testCase.verifyThat(AnyElementOf(actVal), IsFinite);
```

```
Interactive verification passed.
```

Test that at least one element of the actual value is complex.

```
import matlab.unittest.constraints.IsReal
testCase.verifyThat(AnyElementOf([1+0i 4i]), ~IsReal);
```

```
Interactive verification passed.
```

Test that at least one element of the actual value array is less than zero.

```
import matlab.unittest.constraints.IsLessThan;
testCase.verifyThat(AnyElementOf([1 5]), IsLessThan(0));
```

```
Interactive verification failed.
```

```
-----
Framework Diagnostic:
```

```
-----
All elements failed. The first element failed because:
```

```
--> IsLessThan failed.
```

```
    --> The value must be less than the maximum value.
```

```
Actual Value:
```

```
1
Maximum Value (Exclusive):
0
```

```
Actual Value Array:
1    5
```

Neither actual value element is less than zero.

See Also

[matlab.unittest.qualifications | EveryElementOf](#) | [AnyCellOf](#)
| [EveryCellOf](#)

Concepts

matlab.unittest.constraints.BooleanConstraint

Superclasses Constraint

Purpose Interface class for boolean combinations of constraints

Description The BooleanConstraint interface class provides an interface for boolean combinations of Constraints. Any constraint that derives from BooleanConstraint can be combined and negated using the and (&), or (|), and not (~) operators.

Classes that derive from the BooleanConstraint interface class must implement everything required by the standard Constraint interface. When a given constraint is negated, the diagnostics must be written in a different form than for a standard (non-negated) failure. Therefore, classes deriving from the BooleanConstraint class must implement a method to provide a Diagnostic object for the negated case, in addition to the non-negated case.

In exchange for meeting these requirements, all BooleanConstraint implementations inherit the appropriate MATLAB overloads for and, or, and not so that they can be combined with other BooleanConstraints objects or negated.

Methods

and	Form logical conjunction of constraints
getNegativeDiagnosticFor	Produce negated diagnostic for value
not	Form logical negation of constraint
or	Form logical disjunction of constraints

Copy Semantics Value. To learn how value classes affect copy operations, see Copying Objects in the MATLAB documentation.

Examples

Create Boolean HasSameSizeAs Constraint

Create a custom constraint that determines if a given value is the same size as an expected value.

In a file in your working folder, create a file `HasSameSizeAs.m`. The constructor accepts a value to compare to the actual size. This value is stored within the `ValueWithExpectedSize` property. It is recommended that `BooleanConstraint` implementations be immutable, so set the property `SetAccess=immutable`.

```
classdef HasSameSizeAs < matlab.unittest.constraints.BooleanConstraint
    properties(SetAccess=immutable)
        ValueWithExpectedSize
    end

    methods
        function constraint = HasSameSizeAs(value)
            constraint.ValueWithExpectedSize = value;
        end
    end
end
```

Include these methods in the `methods` block in `HasSameSizeAs.m`. Since the `BooleanConstraint` class is a subclass of `Constraint`, classes that derive from it must implement the `satisfiedBy` and `getDiagnosticFor` methods. For more information about these methods, see `matlab.unittest.constraints.Constraint`.

```
    methods
        function bool = satisfiedBy(constraint, actual)
            bool = isequal(size(actual), size(constraint.ValueWithExpectedSize));
        end
        function diag = getDiagnosticFor(constraint, actual)
            import matlab.unittest.diagnostics.StringDiagnostic;

            if constraint.satisfiedBy(actual)
```

matlab.unittest.constraints.BooleanConstraint

```
        diag = StringDiagnostic('HasSameSizeAs passed.');
```

```
    else
```

```
        diag = StringDiagnostic(sprintf(...
```

```
            'HasSameSizeAs failed.\nActual Size: [%s]\nExpectedSi
```

```
            int2str(size(actual)), int2str(size(constraint.ValueW
```

```
        end
```

```
    end
```

```
end
```

Include the `getNegativeDiagnosticFor` method in the `a` methods block with protected access in `HasSameSizeAs.m`. Classes that derive from `BooleanConstraint` must implement the `getNegativeDiagnosticFor` method. This method must provide a `Diagnostic` object that is expressed in the negative sense of the constraint.

```
    methods(Access=protected)
```

```
        function diag = getNegativeDiagnosticFor(constraint, actual)
```

```
            import matlab.unittest.diagnostics.StringDiagnostic;
```

```
            if constraint.satisfiedBy(actual)
```

```
                diag = StringDiagnostic(sprintf(...
```

```
                    ['Negated HasSameSizeAs failed.\nSize [%s] of ' ...
```

```
                    'Actual Value and Expected Value were the same ' ...
```

```
                    'but should not have been.'], int2str(size(actual)))
```

```
            else
```

```
                diag = StringDiagnostic('Negated HasSameSizeAs passed.');
```

```
            end
```

```
        end
```

```
    end
```

In exchange for implementing the required methods, the constraint inherits the appropriate `and`, `or`, and `not` overloads so it can be combined with other `BooleanConstraint` objects or negated.

HasSameSizeAs Class Definition Summary

```
classdef HasSameSizeAs < matlab.unittest.constraints.BooleanConstraint
```

```
    properties(SetAccess=immutable)
```

matlab.unittest.constraints.BooleanConstraint

```
        ValueWithExpectedSize
    end
    methods
        function constraint = HasSameSizeAs(value)
            constraint.ValueWithExpectedSize = value;
        end
        function bool = satisfiedBy(constraint, actual)
            bool = isequal(size(actual), size(constraint.ValueWithExpectedSize));
        end
        function diag = getDiagnosticFor(constraint, actual)
            import matlab.unittest.diagnostics.StringDiagnostic;

            if constraint.satisfiedBy(actual)
                diag = StringDiagnostic('HasSameSizeAs passed.');
            else
                diag = StringDiagnostic(sprintf(...
                    'HasSameSizeAs failed.\nActual Size: [%s]\nExpected Size: [%s]',
                    int2str(size(actual)), ...
                    int2str(size(constraint.ValueWithExpectedSize))));
            end
        end
    end
    methods(Access=protected)
        function diag = getNegativeDiagnosticFor(constraint, actual)
            import matlab.unittest.diagnostics.StringDiagnostic;
            if constraint.satisfiedBy(actual)
                diag = StringDiagnostic(sprintf(...
                    ['Negated HasSameSizeAs failed.\nSize [%s] of ' .
                    'Actual Value and Expected Value were the same ' .
                    'but should not have been.'], int2str(size(actual), 1, 2)));
            else
                diag = StringDiagnostic('Negated HasSameSizeAs passed.');
            end
        end
    end
end
end
```

matlab.unittest.constraints.BooleanConstraint

At the command prompt, create a test case for interactive testing.

```
import matlab.unittest.TestCase
import matlab.unittest.constraints.HasLength;
```

```
testCase = TestCase.forInteractiveUse;
```

Test a passing case.

```
testCase.verifyThat(zeros(5), HasLength(5) | ~HasSameSizeAs(repmat(1,5)))
```

```
Interactive verification passed.
```

The test passes because one of the or conditions, `HasLength(5)`, is true.

Test a failing case.

```
testCase.verifyThat(zeros(5), HasLength(5) & ~HasSameSizeAs(repmat(1,5)))
```

```
Interactive verification failed.
```

```
-----
Framework Diagnostic:
-----
```

```
AndConstraint failed.
```

```
--> + [First Condition]:
```

```
    |   HasLength passed.
```

```
--> AND
```

```
    + [Second Condition]:
```

```
    |   Negated HasSameSizeAs failed.
```

```
    |   Size [5  5] of Actual Value and Expected Value were the same but
```

```
    -+-----
```

The test fails because one of the and conditions, `~HasSameSizeAs(repmat(1,5))`, is false.

See Also

Diagnostic | `matlab.unittest.constraints`

Concepts

matlab.unittest.constraints.BooleanConstraint.and

Purpose Form logical conjunction of constraints

Syntax `outConstObj = and(constObj1, constObj2)`

Description `outConstObj = and(constObj1, constObj2)` forms the logical conjunction of combinable constraints. The `and` method returns a constraint, `outConstObj`, that is the boolean conjunction of `constObj1` and `constObj2`. If `constObj1` and `constObj2` are not satisfied by the actual value provided, the comparison results in a qualification failure.

Typically, the `and` method is not called directly, but the `and` operator, `&`, is used to denote the conjunction of any two combinable constraints.

Input Arguments

constObj
BooleanConstraint instance

Examples Implement and method

```
import matlab.unittest.TestCase;
import matlab.unittest.constraints.ContainsSubstring;
import matlab.unittest.constraints.HasElementCount;
import matlab.unittest.constraints.HasSize;
import matlab.unittest.constraints.IsEmpty;
import matlab.unittest.constraints.IsInstanceOf;
import matlab.unittest.constraints.IsGreaterThan;
import matlab.unittest.constraints.IsGreaterThanOrEqualTo;
import matlab.unittest.constraints.IsOfClass;
import matlab.unittest.constraints.IsReal;

% Create a TestCase for interactive use
testCase = TestCase.forInteractiveUse;

% Passing qualifications
testCase.verifyThat(3, IsReal & IsGreaterThanOrEqualTo(3));
testCase.verifyThat('Some char', IsOfClass(?char) & ~IsEmpty);
testCase.verifyThat([1 2 3; 4 5 6], HasLength(3) & HasElementCount(6));
```

```
% Failing qualifications
testCase.verifyThat(3+i, IsGreaterThan(4), & IsReal);
testCase.verifyThat({1, 2}, IsInstanceOf(?cell) & HasSize([1 2]));
testCase.verifyThat('', ContainsSubstring('string') & IsEmpty);
```

See Also

or | not |

matlab.unittest.constraints.BooleanConstraint.getNegativeDiagnosticFor

Purpose Produce negated diagnostic for value

Syntax `diag = getNegativeDiagnosticFor(constObj, actVal)`

Description `diag = getNegativeDiagnosticFor(constObj, actVal)` produces a negated diagnostic for a value. The `getNegativeDiagnosticFor` method analyzes the provided value, `actVal`, against the constraint, `constObj`, and produces a `matlab.unittest.diagnostics.Diagnostic` object, `diag`, which corresponds to the negation of the constraint, `constObj`. This method is a protected method.

The diagnostics that this method produces are expressed in the negative sense of the constraint. For example, a hypothetical `IsTasty` constraint, when negated, should express that the actual value was "tasty", when it should not have been, and it should describe the details on why it was found to be tasty.

Like the `getDiagnosticFor` method of `Constraint`, the `getNegativeDiagnosticFor` is only called upon failures, and thus can afford a more detailed analysis than the `satisfiedBy` method.

Input Arguments

constObj
BooleanConstraint instance

actVal
Value for comparison

Examples **Implement getNegativeDiagnosticFor method**

```
function diag = getNegativeDiagnosticFor(constraint, actual)
% getNegativeDiagnosticFor - produce a diagnostic when the constraint is
%
% This method is called by the testing framework when the constraint has
% been met but should not have been met because it was negated in a
% boolean expression. It should produce a Diagnostic result that
% describes the failure in the correct terms which express the
% requirement that the constraint actually should not have been met.
```

matlab.unittest.constraints.BooleanConstraint.getNegative

```
import matlab.unittest.diagnostics.StringDiagnostic;

if constraint.satisfiedBy(actual)
    % Create the negative diagnostic. This will show information such
    % constraint class name and display the raw actual and expected va
    % Using the DiagnosticSense.NegativeDiagnostic enumeration also
    % produces language more appropriate for the negated case.
    diag = StringDiagnostic(sprintf(...
        'Negated HasSameSizeAs failed.\nSize [%s] of Actual Value and
        int2str(size(actual))));
else
    % Produce a passing diagnostic, with language appropriate for the
    diag = StringDiagnostic('Negated HasSameSizeAs passed. ');
end %if

end %function
```

See Also

[getDiagnosticFor](#) | [satisfiedBy](#) | [Diagnostic](#) | [not](#)

matlab.unittest.constraints.BooleanConstraint.not

Purpose Form logical negation of constraint

Syntax `negConstObj = not(constObj)`

Description `negConstObj = not(constObj)` forms the logical negation of a negatable constraint. The `not` method returns a constraint, `negConstObj`, that is the boolean complement of the constraint object, `constObj`. This is a means to specify that the constraint should not be satisfied by the actual value provided, and that a qualification failure should be produced when the constraint is satisfied.

Typically, the `not` method is not called directly, but the tilde operator, `~`, is used to denote the negation of any given negatable constraint. Upon encountering a failure, the `getNegativeDiagnosticFor` method provides the resulting constraint diagnostics.

Input Arguments

constObj
BooleanConstraint instance

Examples Implement not method

```
import matlab.unittest.TestCase;
import matlab.unittest.constraints.HasNaN;
import matlab.unittest.constraints.IsEmpty;
import matlab.unittest.constraints.IsEqualTo;
import matlab.unittest.constraints.IsInstanceOf;
import matlab.unittest.constraints.IsReal;
import matlab.unittest.constraints.IsOfClass;

% Create a TestCase for interactive use
testCase = TestCase.forInteractiveUse;

% Passing qualifications
testCase.verifyThat(3, ~IsEqualTo(4));
testCase.verifyThat('Some char', ~IsInstanceOf(?double));
testCase.verifyThat(3, ~HasNaN);
```

```
% Failing qualifications
testCase.verifyThat(3, ~IsReal);
testCase.verifyThat('Some char', ~IsOfClass('char'));
testCase.verifyThat([], ~IsEmpty);
```

See Also

[getNegativeDiagnosticFor](#) |
[matlab.unittest.constraints.BooleanConstraint](#) | [and](#) | [or](#)

matlab.unittest.constraints.BooleanConstraint.or

Purpose Form logical disjunction of constraints

Syntax `outConstObj = or(constObj1, constObj2)`

Description `outConstObj = or(constObj1, constObj2)` forms the logical disjunction of combinable constraints. The `or` method returns a constraint, `outConstObj`, that is the boolean disjunction of `constObj1` and `constObj2`. The comparison only results in a qualification failure if both `constObj1` and `constObj2` are not satisfied by the provided actual value.

Typically, the `or` method is not called directly, but the `or` operator, `|`, is used to denote the disjunction of any two combinable constraints.

Input Arguments

constObj
BooleanConstraint instance

Examples **Implement or method**

```
import matlab.unittest.TestCase;
import matlab.unittest.constraints.HasInf;
import matlab.unittest.constraints.HasNaN;
import matlab.unittest.constraints.EndsWithSubstring;
import matlab.unittest.constraints.IsEqualTo;
import matlab.unittest.constraints.IsGreaterThan;
import matlab.unittest.constraints.IsLessThan;
import matlab.unittest.constraints.IsOfClass;
import matlab.unittest.constraints.IsReal;
import matlab.unittest.constraints.StartsWithSubstring;

% Create a TestCase for interactive use
testCase = TestCase.forInteractiveUse;

% Passing qualifications
testCase.verifyThat([3 NaN 5], HasNaN | HasInf);
testCase.verifyThat(5, IsEqualTo(5) | IsLessThan(0));
```



```
testCase.verifyThat(-3, IsEqualTo(5) | IsLessThan(0));

% Failing qualifications
testCase.verifyThat(3+i, IsGreaterThan(4), | IsReal);
testCase.verifyThat(true, IsOfClass(?char) | IsOfClass(?cell));
testCase.verifyThat('Some long string', StartsWithSubstring('long') |
```

See Also

and | not

matlab.unittest.constraints.CellComparator

Purpose	Comparator for cell arrays
Description	The CellComparator compares cell arrays.
Construction	<p>CellComparator creates a comparator for cell arrays.</p> <p>CellComparator(compObj) indicates a comparator, compObj, that defines the comparator used to compare values contained in the cell array. By default, a cell comparator only supports empty cell arrays.</p> <p>CellComparator(__,Name,Value) provides a comparator with additional options specified by one or more Name,Value pair arguments. Name must appear inside single quotes (' '). You can specify several name-value pair arguments in any order as Name1,Value1,...,NameN,ValueN.</p>
Input Arguments	<p>compObj Comparator object</p> <p>Name-Value Pair Arguments</p> <p>Specify optional comma-separated pairs of Name,Value arguments. Name is the argument name and Value is the corresponding value. Name must appear inside single quotes (' '). You can specify several name and value pair arguments in any order as Name1,Value1,...,NameN,ValueN.</p> <p>'IgnoringCase'</p> <p>Indicator whether the comparator is insensitive to case, specified as false or true (logical 0 or 1). When it is false, the comparator is sensitive to case. The comparator only utilizes this name-value pair if the contents being compared are strings.</p> <p>Default: false</p> <p>'IgnoringWhitespace'</p>

Indicator whether the comparator is insensitive to whitespace, specified as `false` or `true` (logical 0 or 1). When it is `false`, the comparator is sensitive to whitespace. Whitespace characters are space, form feed, new line, carriage return, horizontal tab, and vertical tab. The comparator only utilizes this name-value pair if the contents being compared are strings.

Default: `false`

'Recursively'

Indicator of whether comparator operates recursively, specified as `false` or `true` (logical 0 or 1). When this value is `false`, the comparator does not operate recursively on its data.

When the value is `true`, the data types the cell comparator supports are fully supported in recursion. For example:

```
comp1 = CellComparator(StringComparator)
comp2 = CellComparator(StringComparator, 'Recursively', true)
```

Both `comp1` and `comp2` support a cell arrays of strings. However, only `comp2` supports cell arrays that recursively contain either cell arrays or strings as their elements.

Default: `false`

'Within'

Tolerance to use for numerical comparison, specified as a `matlab.unittest.constraints.Tolerance` object. The comparator only utilizes this name-value pair if the contents being compared are a numeric type.

Default: (empty)

matlab.unittest.constraints.CellComparator

Properties

IgnoreCase

Indicator whether the comparator is insensitive to case, specified in the name-value pair argument, 'IgnoringCase'.

IgnoreWhitespace

Indicator whether the comparator is insensitive to whitespace, specified in the name-value pair argument, 'IgnoringWhitespace'.

Recursive

Indicator of whether comparator operates recursively, specified in the name-value pair argument, 'Recursively'.

Tolerance

Specific tolerance used in construction of the comparator, specified as a `matlab.unittest.constraints.Tolerance` object in the name-value pair argument, 'Within'.

Copy Semantics

Value. To learn how value classes affect copy operations, see Copying Objects in the MATLAB documentation.

Examples

Compare Cell Arrays

Create a test case for interactive testing.

```
import matlab.unittest.constraints.CellComparator;
import matlab.unittest.constraints.StringComparator;
import matlab.unittest.constraints.IsEqualTo;
```

```
testCase = matlab.unittest.TestCase;
```

Use a `CellComparator` to test that two cell arrays are equal to each other.

```
actual = {'abc', 'def'};
expected = {'abc', 'def'};
testCase.verifyThat(actual, IsEqualTo(expected, ...
```

```
'Using', CellComparator(StringComparator)));
```

Interactive verification passed.

By default, the `CellComparator` only supports comparison empty cell arrays, it is necessary to pass it a `StringComparator`.

Change the actual value and compare it to the expected value. For the constraint to be satisfied, it is necessary that you construct the constraint to ignore case and whitespace.

```
actual = {'ABC', 'D E F'};
testCase.verifyThat(actual, IsEqualTo(expected, 'Using', ...
    CellComparator(StringComparator, ...
    'IgnoringWhitespace', true, 'IgnoringCase', true)));
```

Interactive verification passed.

Test nested cell arrays of strings by constructing the comparator to operate recursively.

```
actual = {'abc', {'def', 'ghi'}};
expected = {'abc', {'def', 'ghi'}};

testCase.verifyThat(actual, IsEqualTo(expected, 'Using', ...
    CellComparator(StringComparator, 'Recursively', true)));
```

Interactive verification passed.

See Also

[matlab.unittest.constraints.IsEqualTo](#) |
[matlab.unittest.constraints.Tolerance](#)

Concepts

matlab.unittest.constraints.Constraint

Purpose Fundamental interface class for comparisons

Description The Constraint interface class is the means by which `matlab.unittest.constraints` encode comparison logic and the corresponding diagnostic information. Every comparison that conditionally can produce a failure inherits from the Constraint interface class.

Classes deriving from the Constraint interface class must provide a means to determine if a given value satisfies the constraint. To do this, implement the `satisfiedBy` method, which includes the definition of the underlying comparison logic. Classes deriving from the Constraint class also must provide a diagnostic for any given actual value. The testing framework uses the diagnostic when it encounters a qualification failure. To do this, implement the `getDiagnosticFor` method.

In exchange for meeting these requirements, all Constraint implementations are easily used with all qualification types through the `verifyThat`, `assertThat`, `assumeThat`, or `fatalAssertThat` methods. The qualifications use the comparison and diagnostic knowledge contained within the constraints. Also, the constraints can be used in situations where a test failure is not wanted, but the testing framework needs to reuse the comparison logic. For example, a constraint implementation may want to use the logic defined inside of another constraint. Since the constraint can interact with the other constraint directly, it can use the logic without the potential of causing a qualification failure.

Methods

<code>getDiagnosticFor</code>	Produce diagnostic for compared value
<code>satisfiedBy</code>	Determine whether value satisfies constraint

Copy Semantics Value. To learn how value classes affect copy operations, see Copying Objects in the MATLAB documentation.

Examples

Create HasSameSizeAs Constraint

Create a custom constraint that determines if a given value is the same size as an expected value.

In a file in your working folder, create a `HasSameSizeAs.m`. The constructor accepts a value to compare to the actual size. This value is stored within the `ValueWithExpectedSize` property. Since, it is recommended that `Constraint` implementations are immutable, set the property `SetAccess=immutable`.

```
classdef HasSameSizeAs < matlab.unittest.constraints.Constraint

    properties(SetAccess=immutable)
        ValueWithExpectedSize
    end

    methods
        function constraint = HasSameSizeAs(value)
            constraint.ValueWithExpectedSize = value;
        end
    end
end
```

Classes that derive from `Constraint` must implement the `satisfiedBy` method. This method must contain the comparison logic and return a boolean value.

Include the `satisfiedBy` method in the `methods` block in `HasSameSizeAs.m`.

```
function bool = satisfiedBy(constraint, actual)
    bool = isequal(size(actual), size(constraint.ValueWithExp
end
```

This method returns true if the actual size and expected size are equal.

Classes deriving from `Constraint` must implement the `getDiagnosticFor` method. This method must evaluate the actual

matlab.unittest.constraints.Constraint

value against the constraint and provide a Diagnostic object. In this example, `getDiagnosticFor` returns a `StringDiagnostic`. Include the `getDiagnosticFor` method in the methods block in `HasSameSizeAs.m`.

```
function diag = getDiagnosticFor(constraint, actual)
    import matlab.unittest.diagnostics.StringDiagnostic;

    if constraint.satisfiedBy(actual)
        diag = StringDiagnostic('HasSameSizeAs passed.');
```

```
    else
        diag = StringDiagnostic(sprintf(...
            'HasSameSizeAs failed.\nActual Size: [%s]\nExpectedSi
            int2str(size(actual)), int2str(size(constraint.ValueW
    end
end
```

At the command prompt, create a test case for interactive testing.

```
import matlab.unittest.TestCase

testCase = TestCase.forInteractiveUse;

Test a passing case.

testCase.verifyThat(zeros(5), HasSameSizeAs(repmat(1,5)));

Interactive verification passed.

Test a failing case.

testCase.verifyThat(zeros(5), HasSameSizeAs(ones(1,5)));

Interactive verification failed.

-----
Framework Diagnostic:
-----
HasSameSizeAs failed.
Actual Size: [5 5]
```

ExpectedSize: [1 5]

See Also

[Diagnostic](#) | [ConstraintDiagnostic](#) | [assertThat](#) | [assumeThat](#) | [fatalAssertThat](#) | [verifyThat](#) | [matlab.unittest.constraints](#)

Concepts

matlab.unittest.constraints.Constraint.getDiagnosticFor

Purpose Produce diagnostic for compared value

Syntax `diag = getDiagnosticFor(constObj,actVal)`

Description `diag = getDiagnosticFor(constObj,actVal)` produces a diagnostic, `diag`, for a compared value, `actVal`. When creating a custom constraint, the class author must implement the `getDiagnosticFor` method so that it analyzes the value, `actVal`, against the constraint, `constObj`, and instantiates and returns a `matlab.unittest.diagnostics.Diagnostic` object.

Typically, the testing framework calls this method when it encounters a qualification failure. Therefore, the constraint author can afford to undertake a more detailed analysis in the `getDiagnosticFor` method than the `satisfiedBy` method.

Input Arguments

actVal
Value for comparison

constObj
Constraint instance

Output Arguments

diag
Diagnostic instance

Examples See example for `matlab.unittest.constraints.Constraint`.

See Also `satisfiedBy` | `Diagnostic` | `ConstraintDiagnostic`

matlab.unittest.constraints.Constraint.satisfiedBy

Purpose Determine whether value satisfies constraint

Syntax `TF = satisfiedBy(constObj, actVal)`

Description `TF = satisfiedBy(constObj, actVal)` determines whether a value, `actVal`, satisfies a constraint, `constObj`. The `satisfiedBy` method is used to determine qualification success or failure. It returns `true` or `false` (logical 0 or 1). When creating a custom constraint, a class author must place comparison logic in this method.

Since the most common usage is for the passing case, the constraint author should optimize for speed in that case. It is only in the failing case that more expensive detailed analysis is helpful.

Input Arguments

actVal

Value to evaluate against the constraint

constObj

Constraint instance

Examples See example for `matlab.unittest.constraints.Constraint`.

See Also `getDiagnosticFor`

matlab.unittest.constraints.ContainsSubstring

Superclasses BooleanConstraint

Purpose Constraint specifying string containing substring

Construction ContainsSubstring(substring) creates a constraint that specifies a string containing a substring, `substring`. The constraint is satisfied only if the actual value contains an expected string.

ContainsSubstring(substring,Name,Value) provides a constraint with additional options specified by one or more `Name,Value` pair arguments. `Name` must appear inside single quotes (' '). You can specify several name-value pair arguments in any order as `Name1,Value1,...,NameN,ValueN`.

Input Arguments

substring

Text that must be contained within the actual value, specified as a string. `substring` can include newline characters.

Name-Value Pair Arguments

Specify optional comma-separated pairs of `Name,Value` arguments. `Name` is the argument name and `Value` is the corresponding value. `Name` must appear inside single quotes (' '). You can specify several name and value pair arguments in any order as `Name1,Value1,...,NameN,ValueN`.

IgnoringCase

Indicator if the constraint is insensitive to case, specified as `false` or `true` (logical 0 or 1)

Default: `false`

IgnoringWhitespace

Indicator if the constraint is insensitive to whitespace, specified as `false` or `true` (logical 0 or 1)

Default: false

Properties

IgnoreCase

Indicator if the constraint is insensitive to case, specified in the name-value pair argument, 'IgnoringCase'. This property applies at all levels of recursion, such as nested structures.

IgnoreWhitespace

Indicator if the constraint is insensitive to whitespace, specified in the name-value pair argument, 'IgnoringWhitespace'. This property applies at all levels of recursion, such as nested structures.

Substring

String that must be included in the actual value, specified in the input argument, substring.

Copy Semantics

Value. To learn how value classes affect copy operations, see Copying Objects in the MATLAB documentation.

Examples

Test That Actual Value Contains Specified Substring

Create a test case for interactive testing.

```
import matlab.unittest.TestCase
import matlab.unittest.constraints.ContainsSubstring;
```

```
testCase = TestCase.forInteractiveUse;
```

Define the actual value string.

```
actVal = 'This Is One Long String';
```

Test the actVal contains the substring 'One'.

```
testCase.verifyThat(actVal, ContainsSubstring('One'));
```

matlab.unittest.constraints.ContainsSubstring

Interactive verification passed.

Test the actVal contains the substring 'long'.

```
testCase.verifyThat(actVal, ContainsSubstring('long'));
```

Interactive verification failed.

Framework Diagnostic:

ContainsSubstring failed.

--> The string must contain the substring.

Actual String:

 This Is One Long String

Expected Substring:

 long

By default, the `ContainsSubstring` constraint is case sensitive.

Repeat the test ignoring case.

```
testCase.verifyThat(actVal, ContainsSubstring('long',...  
    'IgnoringCase', true));
```

Interactive verification passed.

Test actVal contains the substring 'thisisone'. For the test to pass, configure the constraint to ignore whitespace and case.

```
testCase.verifyThat(actVal, ContainsSubstring('thisisone', ...  
    'IgnoringCase', true, 'IgnoringWhitespace', true));
```

Interactive verification passed.

Assert that actVal does not contain the substring 'longer'.

```
testCase.assertThat(actVal, ~ContainsSubstring('longer',...
```

```
'IgnoringCase', true));
```

```
Interactive verification passed.
```

See Also

[IsSubstringOf](#) | [EndsWithSubstring](#) | [StartsWithSubstring](#) | [Matches](#)

Concepts

matlab.unittest.constraints.EndsWithSubstring

Superclasses BooleanConstraint

Purpose Constraint specifying string ending with substring

Construction `EndsWithSubstring(suffix)` creates a constraint specifying a string ending with a substring. The constraint is satisfied only if the actual value ends with an expected string, `suffix`.

`EndsWithSubstring(suffix,Name,Value)` provides a constraint with additional options specified by one or more `Name,Value` pair arguments. `Name` must appear inside single quotes (' '). You can specify several name-value pair arguments in any order as `Name1,Value1,...,NameN,ValueN`.

Input Arguments

suffix

Text that occurs at the end of the actual value, specified as a string. `suffix` can include newline characters.

Name-Value Pair Arguments

Specify optional comma-separated pairs of `Name,Value` arguments. `Name` is the argument name and `Value` is the corresponding value. `Name` must appear inside single quotes (' '). You can specify several name and value pair arguments in any order as `Name1,Value1,...,NameN,ValueN`.

IgnoringCase

Indicator if the constraint is insensitive to case, specified as `false` or `true` (logical 0 or 1)

Default: `false`

IgnoringWhitespace

Indicator if the constraint is insensitive to whitespace, specified as `false` or `true` (logical 0 or 1)

Default: false

Properties

IgnoreCase

Indicator if the constraint is insensitive to case, specified in the name-value pair argument, 'IgnoringCase'. This property applies at all levels of recursion, such as nested structures.

IgnoreWhitespace

Indicator if the constraint is insensitive to whitespace, specified in the name-value pair argument, 'IgnoringWhitespace'. This property applies at all levels of recursion, such as nested structures.

Suffix

Text that occurs at the end of the actual value, specified in the input argument, `suffix`.

Copy Semantics

Value. To learn how value classes affect copy operations, see Copying Objects in the MATLAB documentation.

Examples

Test That Actual Value Ends with Specified Substring

Create a test case for interactive testing.

```
import matlab.unittest.TestCase
import matlab.unittest.constraints.EndsWithSubstring;
```

```
testCase = TestCase.forInteractiveUse;
```

Define the actual value string.

```
actVal = 'This Is One Long String';
```

Test the `actVal` ends with the substring 'String'.

```
testCase.verifyThat(actVal, EndsWithSubstring('String'));
```

matlab.unittest.constraints.EndsWithSubstring

Interactive verification passed.

Test the actVal ends with the substring 'InG'.

```
testCase.verifyThat(actVal, EndsWithSubstring('InG'));
```

Interactive verification failed.

Framework Diagnostic:

EndsWithSubstring failed.

--> The string has an incorrect suffix.

Actual String:

 This Is One Long String

Expected Suffix:

 InG

By default, the `EndsWithSubstring` constraint is case sensitive.

Repeat the test ignoring case.

```
testCase.verifyThat(actVal, EndsWithSubstring('InG',...  
    'IgnoringCase', true));
```

Interactive verification passed

Test the actVal ends with the substring 'longstring'. For the test to pass, configure the constraint to ignore whitespace and case.

```
testCase.verifyThat(actVal, EndsWithSubstring('longstring', ...  
    'IgnoringCase', true, 'IgnoringWhitespace', true));
```

Interactive verification passed.

Assert that actVal does not end with the substring 'long'.

```
testCase.assertThat(actVal, ~EndsWithSubstring('long'));
```

Interactive verification passed.

See Also

[ContainsSubstring](#) | [IsSubstringOf](#) | [StartsWithSubstring](#) | [Matches](#)

Concepts

matlab.unittest.constraints.Eventually

Superclasses Constraint

Purpose Poll for value to asynchronously satisfy constraint

Construction `outConstObj = Eventually(constObj)` creates a constraint, `outConstObj`, that polls for an actual value function handle to asynchronously satisfy the constraint specified in the `constObj` constraint. It is not satisfied if evaluation of the function handle does not produce a value that satisfies the constraint within 20 seconds. The testing framework invokes the `drawnow` function while the `Eventually` constraint waits for specified function to satisfy the constraint.

`outConstObj = Eventually(constObj, 'WithTimeoutOf', timeOutVal)` creates a constraint that polls for the constraint to be satisfied within the timer period specified in `timeOutVal`.

Input Arguments

constObj

Constraint instance

timeOutVal

Maximum time to wait for passing behavior, specified in seconds

Default: 20 seconds

Properties **TimeOut**

Maximum time to wait for passing behavior, specified by the `timeOutVal` input argument

Copy Semantics

Value. To learn how value classes affect copy operations, see Copying Objects in the MATLAB documentation.

Examples

Verify Test Passes Eventually

Create a test case for interactive testing.

```
import matlab.unittest.TestCase;
import matlab.unittest.constraints.Eventually
import matlab.unittest.constraints.IsGreaterThan
import matlab.unittest.constraints.IsLessThan
```

```
testCase = TestCase.forInteractiveUse;
```

Verify that, within the timeout period, a call to `toc` results in a value greater than 10 (seconds). The `Eventually` constraint repeatedly calls `toc` until either the constraint is satisfied or the elapsed time exceeds the timeout period. Repeated calls to `toc` result in the elapsed time since the last call to `tic`.

```
tic;
testCase.verifyThat(@toc, Eventually(IsGreaterThan(10)));
```

```
Interactive verification passed.
```

The verification may take as long as 10 seconds for `toc` to reach a passing value. If you issue the call to `tic` and wait more than 10 seconds before issuing the `verifyThat` command, the verification returns immediately since `toc` already returns a value greater than 10.

Verify that, within the timeout period, `toc` does not return a negative value.

```
testCase.verifyThat(@toc, Eventually(IsLessThan(0)));
```

```
Interactive verification failed.
```

```
-----
Framework Diagnostic:
-----
```

```
Eventually failed.
```

```
--> The function did not pass after 20 seconds.
```

matlab.unittest.constraints.Eventually

```
--> IsLessThan failed.  
--> The value must be less than the maximum value.
```

```
Actual Value:  
    20.286452356691139  
Maximum Value (Exclusive):  
    0
```

```
Evaluated Function:  
    @toc
```

This failure is expected since elapsed time is not going to be less than zero. However, `Eventually` polls `toc` for the duration of the timeout period.

Adjust the timeout period so `Eventually` polls for 5 seconds.

```
tic;  
testCase.verifyThat(@toc, Eventually(IsGreaterThan(10), ...  
    'WithTimeoutOf', 5));
```

```
Interactive verification failed.
```

```
-----  
Framework Diagnostic:  
-----
```

```
Eventually failed.  
--> The function did not pass after 5 seconds.  
--> IsGreaterThan failed.  
--> The value must be greater than the minimum value.
```

```
Actual Value:  
    5.076293030150061  
Minimum Value (Exclusive):  
    10
```

```
Evaluated Function:  
    @toc
```

If you didn't wait more than 5 seconds between calls to `tic` and `verifyThat`, the test fails because the elapsed time is not greater than 10 seconds within the modified timeout period.

See Also

`drawnow` | `matlab.unittest.constraints.Constraint`

Concepts

matlab.unittest.constraints.EveryCellOf

Purpose Test if all elements of cell array meet constraint

Description The `EveryCellOf` class creates a proxy of the actual value to the framework. The proxy enables a test writer to apply a constraint against each element of a cell array, which ensures that a passing result occurs when every element of the cell array satisfies the constraint.

It is intended that you use this class through `matlab.unittest` qualifications as shown in the examples. The class does not modify the provided actual value, but serves as a wrapper to perform the constraint analysis. The testing framework analyzes the constraint on an element-by-element basis.

Construction `EveryCellOf(actVal)` creates a proxy instance that tests if every element of a provided cell array, `actVal`, meets a constraint. The test passes if all elements satisfy the constraint.

Tips

- `EveryCellOf` checks if every element in the provided cell array satisfies an associated constraint. However, there are some constraints, a prominent one being `IsEqualTo`, that natively validate if all elements in cell arrays satisfy a condition. In these situations, use of `EveryCellOf` is unnecessary and impedes qualification performance.

Input Arguments

`actVal`

Actual value to test against constraint

Properties

`ActualValue`

Actual value to test against constraint. Set this property through the constructor via the `actVal` input argument.

Copy Semantics

Value. To learn how value classes affect copy operations, see Copying Objects in the MATLAB documentation.

Examples

Test That Every Cell Satisfies Constraint

Create a test case for interactive testing.

```
import matlab.unittest.TestCase
import matlab.unittest.constraints.EveryCellOf;
```

```
testCase = TestCase.forInteractiveUse;
```

Test that every cell of `actVal` contains the substring 'ain'.

```
import matlab.unittest.constraints.ContainsSubstring
actVal = {'Rain', 'Main', 'Plain'};
testCase.verifyThat(EveryCellOf(actVal), ContainsSubstring('ain'));
```

```
Interactive verification passed.
```

Test that every cell of the actual value array has two elements.

```
import matlab.unittest.constraints.HasElementCount
testCase.verifyThat(EveryCellOf({'hello', 'world'}, {11 38})), HasElementCount(2));
```

```
Interactive verification passed.
```

Test that every cell of the actual value array is empty.

```
import matlab.unittest.constraints.IsEmpty
testCase.verifyThat(EveryCellOf({inputParser.empty, ''}), IsEmpty)
```

```
Interactive verification passed.
```

Test that every cell of the actual value array is finite.

```
import matlab.unittest.constraints.IsFinite;
testCase.verifyThat(EveryCellOf({NaN, Inf, 5}), IsFinite);
```

matlab.unittest.constraints.EveryCellOf

Interactive verification failed.

Framework Diagnostic:

At least one cell failed.

Failing indices:

1 2

The first failing cell failed because:

--> IsFinite failed.

--> The value must be finite.

Actual Value:

NaN

Actual Value Cell Array:

[NaN] [Inf] [5]

Only the third element has a finite value.

Test that every cell of the actual value array is real.

```
import matlab.unittest.constraints.IsReal
testCase.verifyThat(EveryCellOf({1 4i}), IsReal);
```

Interactive verification failed.

Framework Diagnostic:

At least one cell failed.

Failing indices:

2

The first failing cell failed because:

--> IsReal failed.

--> The value must be real.

Actual Value:

```
0.0000000000000000 + 4.000000000000000i
```

Actual Value Cell Array:

```
[1] [0.0000000000000000 + 4.000000000000000i]
```

The second element has an imaginary value.

See Also

[matlab.unittest.qualifications](#) | [AnyElementOf](#) | [AnyCellOf](#) | [EveryElementOf](#)

Concepts

matlab.unittest.constraints.EveryElementOf

Purpose Test if all elements of array meet constraint

Description The `EveryElementOf` class creates a proxy of the actual value to the framework. The proxy enables a test writer to apply a constraint against each element of an array, which ensures that a passing result occurs when every element of the array that satisfies the constraint.

It is intended that you use this class through `matlab.unittest` qualifications as shown in the examples. The class does not modify the provided actual value, but serves as a wrapper to perform the constraint analysis. The testing framework analyzes the constraint on an element-by-element basis.

Construction `EveryElementOf(actVal)` creates a proxy instance that tests if every element of a provided array, `actVal`, meets a constraint. The test passes if all elements satisfy the constraint.

Tips

- `EveryElementOf` checks if every element in the provided array satisfies an associated constraint. However, there are some constraints, such as `IsEqualTo` and `IsGreaterThan`, `IsLessThan`, that natively validate if all elements in the array satisfy a condition. In these situations, use of `EveryElementOf` is unnecessary and impedes qualification performance.

Input Arguments

`actVal`

Actual value to test against constraint

Properties

`ActualValue`

Actual value to test against constraint. Set this property through the constructor via the `actVal` input argument.

Copy Semantics

Value. To learn how value classes affect copy operations, see Copying Objects in the MATLAB documentation.

Examples

Test That Every Element Satisfies Constraint

Create a test case for interactive testing.

```
import matlab.unittest.TestCase
import matlab.unittest.constraints.EveryElementOf;
```

```
testCase = TestCase.forInteractiveUse;
```

Test that every element of `actVal` is less than 55.

```
import matlab.unittest.constraints.IsLessThan;
actVal = [1 1 2 3 5 8 13 21 34];
testCase.verifyThat(EveryElementOf(actVal), IsLessThan(55));
```

```
Interactive verification passed.
```

Test that every element of the actual value array is complex.

```
import matlab.unittest.constraints.IsReal
testCase.verifyThat(EveryElementOf([1+2i 4i]), ~IsReal);
```

```
Interactive verification passed.
```

Test that every element of the actual value array is less than zero.

```
import matlab.unittest.constraints.IsLessThan;
testCase.verifyThat(EveryElementOf([1 -5]), IsLessThan(0));
```

```
Interactive verification failed.
```

```
-----
Framework Diagnostic:
-----
At least one element failed.
```

matlab.unittest.constraints.EveryElementOf

```
Failing indices:
    1
The first failing element failed because:
--> IsLessThan failed.
    --> The value must be less than the maximum value.

Actual Value:
    1
Maximum Value (Exclusive):
    0

Actual Value Array:
    1    -5
```

Only the second element is less than zero.

Test that every element of the actual value array has a NaN value.

```
import matlab.unittest.constraints.HasNaN;
testCase.verifyThat(EveryElementOf([NaN 0/0 5]), HasNaN);
```

Interactive verification failed.

```
-----
Framework Diagnostic:
-----
```

At least one element failed.

```
Failing indices:
    3
The first failing element failed because:
--> HasNaN failed.
    --> The value must be NaN.
```

```
Actual Value:
    5
```

```
Actual Value Array:
```

```
NaN NaN 5
```

Only the third element has a NaN value.

See Also

[matlab.unittest.qualifications | AnyElementOf | AnyCellOf | EveryCellOf](#)

Concepts

matlab.unittest.constraints.HasElementCount

Superclasses BooleanConstraint

Purpose Constraint specifying expected number of elements

Construction HasElementCount(countVal) provides a constraint that specifies an expected number of elements. The constraint is satisfied if the actual value array has the same number of elements specified as by countVal.

Input Arguments

countVal

Number of elements a value must have to satisfy the constraint.

Properties **Count**

Number of elements a value must have to satisfy the constraint. Set this property through the constructor via the countVal input argument.

Copy Semantics Value. To learn how value classes affect copy operations, see Copying Objects in the MATLAB documentation.

Examples **Test for Expected Number of Elements**

Create a test case for interactive testing.

```
import matlab.unittest.TestCase
import matlab.unittest.constraints.HasElementCount;
```

```
testCase = TestCase.forInteractiveUse;
```

Verify a scalar has an element count of one.

```
testCase.verifyThat(3, HasElementCount(1));
```

```
Interactive verification passed.
```

Test the element count of the vector.

```
testCase.assertThat([42 7 13], HasElementCount(3));
```

Interactive assertion passed.

Test the element count of the matrix.

```
testCase.assertThat([1 2 3; 4 5 6], HasElementCount(5));
```

Interactive assertion failed.

```
-----  
Framework Diagnostic:  
-----  
HasElementCount failed.  
--> The value did not have the correct number of elements.
```

```
    Actual Number of Elements:
```

```
        6
```

```
    Expected Number of Elements:
```

```
        5
```

```
Actual Value:
```

```
    1     2     3  
    4     5     6
```

```
Assertion failed.
```

The matrix has six elements.

Test that a square identity matrix has the correct number of elements.

```
n = 7;  
testCase.assumeThat(eye(n), HasElementCount(n^2));
```

Interactive assumption passed.

Verify the element count of a cell array of strings.

matlab.unittest.constraints.HasElementCount

```
testCase.verifyThat({'aString', 'anotherString'}, HasElementCount(2));
```

```
Interactive verification passed.
```

Test the element count of a structure.

```
s.Field1 = 1;  
s.Field2 = 2;  
testCase.verifyThat(s, HasElementCount(2));
```

```
Interactive verification failed.
```

```
-----  
Framework Diagnostic:  
-----
```

```
HasElementCount failed.
```

```
--> The value did not have the correct number of elements.
```

```
Actual Number of Elements:
```

```
1
```

```
Expected Number of Elements:
```

```
2
```

```
Actual Value:
```

```
Field1: 1
```

```
Field2: 2
```

The structure has two fields, but it only has one element.

```
testCase.verifyThat(s, HasElementCount(1));
```

```
Interactive verification passed.
```

See Also

[numel](#) | [IsEmpty](#) | [HasLength](#) | [HasSize](#)

Concepts

Superclasses BooleanConstraint

Purpose Constraint specifying structure containing particular field

Construction HasField(fieldname) provides a constraint specifying structure containing particular field, fieldname. The constraint is satisfied if the actual value is a structure and that structure contains a field named fieldname.

Input Arguments

fieldname

Name of the field that a structure must contain to satisfy the constraint, specified as a string.

Properties **Field**

Name of the field that a structure must contain to satisfy the constraint. Set this property through the constructor via the fieldname input argument.

Copy Semantics Value. To learn how value classes affect copy operations, see Copying Objects in the MATLAB documentation.

Examples **Test That Structure Has Particular Field**

Create at TestCase for interactive testing.

```
import matlab.unittest.TestCase;  
import matlab.unittest.constraints.HasField;
```

```
testCase = TestCase.forInteractiveUse;
```

Define the following structure, S, with two fields.

```
S = struct('Tag', 123, 'Serial', 345);
```

matlab.unittest.constraints.HasField

Verify that the structure has a 'Tag' field.

```
testCase.verifyThat(S, HasField('Tag'));
```

Interactive verification passed.

Verify that the structure has a 'tag' field.

```
testCase.verifyThat(S, HasField('tag'));
```

Interactive verification failed.

Framework Diagnostic:

HasField failed.

--> The value did not have the expected field.

Actual Fieldnames:

 'Tag'

 'Serial'

Expected Fieldname:

 'tag'

Actual Value:

 Tag: 123

 Serial: 345

The verification fails because the field name comparison is case sensitive.

Verify that the structure has a 'Tag' field.

```
testCase.verifyThat(S, HasField('Tag'));
```

Interactive verification passed.

Verify that the structure has both a 'Tag' and a 'Serial' field.

```
testCase.verifyThat(S, HasField('Tag') & HasField('Serial'));
```

```
Interactive verification passed.
```

Verify that the structure does not have a 'Name' field.

```
testCase.verifyThat(S, ~HasField('Name'));
```

```
Interactive verification passed.
```

Concepts

matlab.unittest.constraints.HasInf

Superclasses BooleanConstraint

Purpose Constraint specifying array containing any infinite value

Construction HasInf creates a constraint that is able to determine if any value of an actual value array is an infinite value. This constraint is satisfied only if the actual value array contains at least one infinite value.

Copy Semantics Value. To learn how value classes affect copy operations, see Copying Objects in the MATLAB documentation.

Examples **Test That Actual Value Array Contains Infinite Value**

Create a test case for interactive testing.

```
import matlab.unittest.TestCase
import matlab.unittest.constraints.HasInf;
```

```
testCase = TestCase.forInteractiveUse;
```

Test that the value Inf satisfies the constraint.

```
testCase.verifyThat(Inf, HasInf);
```

```
Interactive verification passed.
```

Assert that an array contains an infinite value.

```
testCase.assertThat([0 1 1 2 3 5 8 13], HasInf);
```

```
Interactive assertion failed.
```

```
-----
Framework Diagnostic:
-----
```

```
HasInf failed.
```

```
--> At least one element must be Inf or -Inf.
```

```
Actual Value:  
      0      1      1      2      3      5      8     13  
Assertion failed.
```

The array does not contain any infinite values.

Verify that an array contains an infinite value.

```
testCase.verifyThat([-Inf 5 NaN], HasInf);
```

```
Interactive verification passed.
```

Assert that a complex number that is infinite in the imaginary part satisfies the constraint.

```
testCase.assertThat(42+Inf*1i, HasInf);
```

```
Interactive verification passed.
```

Verify that an array does not contain any infinite values.

```
testCase.verifyThat([NaN -7+NaN*1i], ~HasInf);
```

```
Interactive verification passed.
```

Negating the `HasInf` constraint does not ensure the value is finite, only that it does not contain any infinite values.

See Also

`IsFinite` | `HasNaN` | `isinf`

Concepts

matlab.unittest.constraints.HasLength

Superclasses BooleanConstraint

Purpose Constraint specifying expected length of array

Construction HasLength(lengthVal) provides a constraint that specifies an expected length of an array. The constraint is satisfied if the largest dimension length of the actual value array has the same number of elements specified as by lengthVal.

Input Arguments

lengthVal

Length a value must have to satisfy the constraint.

Properties **Count**

Length a value must have to satisfy the constraint. Set this property through the constructor via the lengthVal input argument.

Copy Semantics Value. To learn how value classes affect copy operations, see Copying Objects in the MATLAB documentation.

Examples **Test for Expected Array Length**

Create a test case for interactive testing.

```
import matlab.unittest.TestCase
import matlab.unittest.constraints.HasLength;
```

```
testCase = TestCase.forInteractiveUse;
```

Assert that a 2x5x3 array has an expected length.

```
testCase.assertThat(rand(2, 5, 3), HasLength(5));
```

```
Interactive assertion passed.
```

Verify that a cell array of strings has an expected length.

```
testCase.verifyThat({'SomeString', 'SomeOtherString'}, HasLength(2));
```

```
Interactive verification passed.
```

Verify that an identity matrix has an expected length.

```
testCase.verifyThat(eye(2), HasLength(4));
```

```
Interactive verification failed.
```

```
-----  
Framework Diagnostic:  
-----  
HasLength failed.  
--> The array has an incorrect length.
```

```
Actual Length:  
      2  
Expected Length:  
      4
```

```
Actual Array:  
      1      0  
      0      1
```

The matrix has a length of 2.

See Also Concepts

[IsEmpty](#) | [HasElementCount](#) | [HasSize](#) | [length](#)

matlab.unittest.constraints.HasNaN

Superclasses BooleanConstraint

Purpose Constraint specifying array containing NaN value

Construction HasNaN creates a constraint that is able to determine if any value of an actual value array is NaN. This constraint is satisfied only if the actual value array contains at least one NaN value.

Copy Semantics Value. To learn how value classes affect copy operations, see Copying Objects in the MATLAB documentation.

Examples **Test That Actual Value Array Contains NaN Value**

Create a test case for interactive testing.

```
import matlab.unittest.TestCase
import matlab.unittest.constraints.HasNaN;
```

```
testCase = TestCase.forInteractiveUse;
```

Test that the value NaN satisfies the constraint.

```
testCase.verifyThat(NaN, HasNaN);
```

```
Interactive verification passed.
```

Assert that an array contains a NaN value.

```
testCase.assertThat([0 1 1 2 3 5 8 13], HasNaN);
```

```
Interactive assertion failed.
```

```
-----
Framework Diagnostic:
```

```
-----
HasNaN failed.
```

```
--> At least one element must be NaN.
```

```
Actual Value:
      0      1      1      2      3      5      8     13
Assertion failed.
```

The array does not contain a NaN value.

Verify that an array contains a NaN value.

```
testCase.verifyThat([-Inf 5 NaN], HasNaN);
```

```
Interactive verification passed.
```

Assert that a complex number satisfies the constraint.

```
testCase.assertThat(42+NaN*1i, HasNaN);
```

```
Interactive assertion passed.
```

Verify that an array does not contain any NaN values.

```
testCase.verifyThat([Inf -7+Inf*1i], ~HasNaN);
```

```
Interactive verification passed.
```

Negating the `HasNaN` constraint does not ensure the value is finite, only that it does not contain any NaN values.

See Also

`IsFinite` | `HasInf` | `isnan`

Concepts

matlab.unittest.constraints.HasSize

Superclasses BooleanConstraint

Purpose Constraint specifying expected size of array

Construction `HasSize(sizeVal)` provides a constraint that specifies an expected size of an array. The constraint is satisfied if the actual value array size is equal to the size specified by `sizeVal`.

Input Arguments

sizeVal

Size a value must have to satisfy the constraint.

Properties

Count

Size a value must have to satisfy the constraint. Set this property through the constructor via the `sizeVal` input argument.

Copy Semantics

Value. To learn how value classes affect copy operations, see Copying Objects in the MATLAB documentation.

Examples

Test for Expected Array Size

Create a test case for interactive testing.

```
import matlab.unittest.TestCase
import matlab.unittest.constraints.HasSize;
```

```
testCase = TestCase.forInteractiveUse;
```

Assert that a 2x5x3 array has an expected size.

```
testCase.assertThat(rand(2, 5, 3), HasSize([2 5 3]));
```

```
Interactive assertion passed.
```

Verify that a cell array of strings has an expected size.

```
testCase.verifyThat({'SomeString', 'SomeOtherString'}, HasSize([1 2]))
```

Interactive verification passed.

Verify that an identity matrix has an expected size.

```
testCase.verifyThat(eye(2), HasSize([4 1]));
```

Interactive verification failed.

```
-----  
Framework Diagnostic:  
-----
```

HasSize failed.

--> The value had an incorrect size.

Actual Size:

2 2

Expected Size:

4 1

Actual Value:

1 0

0 1

The matrix has a size of 2x2.

See Also

[IsEmpty](#) | [HasElementCount](#) | [HasLength](#) | [size](#)

Concepts

matlab.unittest.constraints.IsAnything

Superclasses	Constraint
Purpose	Constraint specifying any value
Construction	<code>IsAnything</code> provides a constraint specifying any value. The constraint is satisfied by any value. It is the default constraint for selectors that do not require an input argument.
Copy Semantics	Value. To learn how value classes affect copy operations, see Copying Objects in the MATLAB documentation.
Examples	<p>Instantiate IsAnything Object</p> <p>Create a test case for interactive testing.</p> <pre>import matlab.unittest.TestCase; import matlab.unittest.constraints.IsAnything; testCase = TestCase.forInteractiveUse;</pre> <p>Verify that the following values satisfy the <code>IsAnything</code> constraint: <code>NaN</code>, an <code>inputParser</code> object, a numeric array, and a complex number.</p> <pre>testCase.verifyThat(NaN, IsAnything); testCase.verifyThat(inputParser, IsAnything); testCase.verifyThat(1:10, IsAnything); testCase.verifyThat(-Inf+5j, IsAnything);</pre> <pre>Interactive verification passed. Interactive verification passed. Interactive verification passed. Interactive verification passed.</pre> <p>Test that empty cells, arrays, and strings satisfy the <code>IsAnything</code> constraint.</p> <pre>testCase.verifyThat({}, IsAnything); testCase.verifyThat([], IsAnything);</pre>

```
testCase.verifyThat('', IsAnything);
```

```
Interactive verification passed.  
Interactive verification passed.  
Interactive verification passed.
```

The constraint is satisfied even though the data are empty.

See Also

`matlab.unittest.selectors`

Concepts

matlab.unittest.constraints.IsEmpty

Superclasses	BooleanConstraint
Purpose	Constraint specifying empty value
Construction	IsEmpty provides a constraint that specifies an empty value. The constraint is satisfied if the actual value array is empty.
Copy Semantics	Value. To learn how value classes affect copy operations, see Copying Objects in the MATLAB documentation.

Examples **Test That Actual Value Is Empty**

Create a test case for interactive testing.

```
import matlab.unittest.TestCase
import matlab.unittest.constraints.IsEmpty;
```

```
testCase = TestCase.forInteractiveUse;
```

Verify that an empty string satisfies the IsEmpty constraint.

```
testCase.verifyThat('', IsEmpty);
```

```
Interactive verification passed.
```

Assert that a vector is not empty.

```
testCase.assertThat([13 42], ~IsEmpty);
```

```
Interactive verification passed.
```

Verify that a matrix with a dimension of length zero is empty.

```
testCase.verifyThat(rand(2, 5, 0, 3), IsEmpty);
```

```
Interactive verification passed.
```

Assert that an empty object satisfies the IsEmpty constraint.

```
testCase.assertThat(MException.empty, IsEmpty);
```

Interactive assertion passed.

Verify that a cell array containing an empty numeric array is empty.

```
testCase.verifyThat({[]}, IsEmpty);
```

Interactive verification failed.

```
-----  
Framework Diagnostic:  
-----
```

IsEmpty failed.

--> The value must be empty.

--> The value has a size of [1 1].

Actual Value:

```
{[]}
```

The cell array is not empty, even though the only thing it contains is an empty array.

See Also

[HasCount](#) | [HasLength](#) | [HasSize](#) | [isempty](#)

Concepts

matlab.unittest.constraints.IsFalse

Superclasses	Constraint
Purpose	Constraint specifying false value
Construction	IsFalse provides a constraint specifying a false value. This constraint is satisfied only by a scalar logical with a value of false.
Copy Semantics	Value. To learn how value classes affect copy operations, see Copying Objects in the MATLAB documentation.
Examples	Test Actual Value Is False

Create a test case for interactive testing.

```
import matlab.unittest.TestCase;
import matlab.unittest.constraints.IsFalse;
```

```
testCase = TestCase.forInteractiveUse;
```

Test that false satisfies the IsFalse constraint.

```
testCase.verifyThat(false, IsFalse);
```

```
Interactive verification passed.
```

Test that the IsFalse constraint is not satisfied by true.

```
testCase.verifyThat(true, IsFalse);
```

```
Interactive verification failed.
```

```
-----
Framework Diagnostic:
-----
```

```
IsFalse failed.
```

```
--> The value must evaluate to "false".
```

Actual Value:

1

The test fails because true returns logical(1).

Test that the IsFalse constraint is not satisfied by the double 0.

```
testCase.verifyThat(0, IsFalse);
```

Interactive verification failed.

```
-----  
Framework Diagnostic:  
-----
```

IsFalse failed.

--> The value must be logical. It is of type "double".

Actual Value:

0

The IsFalse constraint is satisfied only by logical(0).

Test that the IsFalse constraint is not satisfied by a logical array of zeros.

```
testCase.verifyThat([false false false], IsFalse);
```

Interactive verification failed.

```
-----  
Framework Diagnostic:  
-----
```

IsFalse failed.

--> The value must be scalar. It has a size of [1 3].

Actual Value:

0 0 0

matlab.unittest.constraints.IsFalse

The `IsFalse` constraint is only satisfied if the value is scalar and `logical(0)`.

See Also `IsTrue`

Concepts

Superclasses BooleanConstraint

Purpose Constraint specifying finite value

Construction IsFinite creates a constraint that is able to determine if all values of an actual value array are finite. This constraint is satisfied only if the actual value array does not contain any infinite or NaN values.

Copy Semantics Value. To learn how value classes affect copy operations, see Copying Objects in the MATLAB documentation.

Examples **Test That Actual Value Array Contains Only Finite Values**

Create a test case for interactive testing.

```
import matlab.unittest.TestCase
import matlab.unittest.constraints.IsFinite;
```

```
testCase = TestCase.forInteractiveUse;
```

Test that the value 17 satisfies the constraint.

```
testCase.verifyThat(17, IsFinite);
```

```
Interactive verification passed.
```

Assert that an array is completely finite.

```
testCase.assertThat([0 1 1 2 3 5 8 13], IsFinite);
```

```
Interactive assertion passed.
```

Verify that an array is completely finite.

```
testCase.verifyThat([-Inf 5 NaN], IsFinite);
```

```
Interactive verification failed.
```

matlab.unittest.constraints.IsFinite

```
-----  
Framework Diagnostic:  
-----  
IsFinite failed.  
--> All elements must be finite-valued.  
    Failing indices:  
           1     3  
  
Actual Value:  
      -Inf     5   NaN
```

The array contains an infinite value.

Test if a complex number that is infinite in the imaginary part satisfies the constraint.

```
testCase.assertThat(42+Inf*1i, IsFinite);
```

```
Interactive assertion failed.
```

```
-----  
Framework Diagnostic:  
-----  
IsFinite failed.  
--> The value must be finite.  
  
Actual Value:  
      42.000000000000000 +          Infi  
Assertion failed.
```

Verify that an array does not contain all finite values.

```
testCase.verifyThat([NaN -7+NaN*1i], ~IsFinite);
```

```
Interactive verification passed.
```

See Also

[HasInf](#) | [HasNaN](#) | [isfinite](#)

Concepts

matlab.unittest.constraints.IsGreaterThan

Superclasses Constraint

Purpose Constraint specifying value greater than another value

Construction `IsGreaterThan(floorVal)` creates a constraint specifying that an actual value is greater than another value. The constraint is satisfied if the actual value array is greater than the specified floor value, `floorVal`. The actual value is greater than `floorVal` only if the result of the expression `actual > floorVal` is nonempty and all values are true.

Input Arguments

floorVal

Largest value that fails the constraint.

Properties **FloorValue**

Largest value that fails the constraint. Set this property through the constructor via the `floorVal` input argument.

Methods

<code>and</code>	Form logical conjunction of constraints
<code>or</code>	Form logical disjunction of constraints

Copy Semantics Value. To learn how value classes affect copy operations, see Copying Objects in the MATLAB documentation.

Examples **Test That Actual Value Is Greater Than Provided Floor Value**

Create a test case for interactive testing.

```
import matlab.unittest.TestCase
import matlab.unittest.constraints.IsGreaterThan;
```



```
testCase = TestCase.forInteractiveUse;
```

Test that the actual value is greater than two.

```
actVal = 3;  
testCase.verifyThat(actVal, IsGreaterThan(2));
```

Interactive verification passed.

Test that the actual value is greater than three.

```
testCase.verifyThat(actVal, IsGreaterThan(3));
```

Interactive verification failed.

```
-----  
Framework Diagnostic:  
-----  
IsGreaterThan failed.  
--> The value must be greater than the minimum value.
```

```
Actual Value:  
    3  
Minimum Value (Exclusive):  
    3
```

The actual value is equal to, not greater than, three.

Test that each element in the actual value array is greater than four.

```
actVal = [5 6 7];  
testCase.verifyThat(actVal, IsGreaterThan(4));
```

Interactive verification passed.

Test that each element in the actual value matrix is greater than four.

```
actVal = [1 2 3; 4 5 6];
```

matlab.unittest.constraints.IsGreaterThan

```
testCase.verifyThat(actVal, IsGreaterThan(4));
```

```
testCase.verifyThat(actVal, IsGreaterThan(4));  
Interactive verification failed.
```

```
-----  
Framework Diagnostic:  
-----
```

```
IsGreaterThan failed.  
--> Each element must be greater than the minimum value.
```

```
    Failing Indices:  
           1     2     3     5
```

```
Actual Value:  
           1     2     3  
           4     5     6  
Minimum Value (Exclusive):  
           4
```

The matrix contains four elements with a value less than or equal to four.

Test that the actual value, 5, is greater than every element in an array.

```
testCase.verifyThat(5, IsGreaterThan([1 2 3]));
```

```
Interactive verification passed.
```

Test that elements in the actual value array are greater than the corresponding floor values.

```
testCase.verifyThat([5 -3 2], IsGreaterThan([4 -9 0]));
```

```
Interactive verification passed.
```

Repeat the test, this time negating the first actual value element.

```
testCase.verifyThat([-5 -3 2], IsGreaterThan([4 -9 0]));
```

Interactive verification failed.

Framework Diagnostic:

IsGreaterThan failed.

--> Each element must be greater than each corresponding element of the

Failing Indices:

1

Actual Value:

-5 -3 2

Minimum Value (Exclusive):

4 -9 0

The negated element is less than four.

See Also

[gt](#) | [IsGreaterThanOrEqualTo](#) | [IsLessThanOrEqualTo](#) | [IsLessThan](#)

Concepts

matlab.unittest.constraints.IsGreaterThanOrEqualTo

Superclasses Constraint

Purpose Constraint specifying value greater than or equal to another value

Construction `IsGreaterThanOrEqualTo(floorVal)` creates a constraint specifying that an actual value is greater than or equal to another value. The constraint is satisfied if the actual value array is greater than or equal to the specified floor value, `floorVal`. The actual value is greater than or equal to `floorVal` only if the result of the expression `actual >= floorVal` is nonempty and all values are true.

Input Arguments

floorVal

Minimum value to satisfy the constraint.

Properties **FloorValue**

Minimum value to satisfy the constraint. Set this property through the constructor via the `floorVal` input argument.

Methods

<code>and</code>	Form logical conjunction of constraints
<code>or</code>	Form logical disjunction of constraints

Copy Semantics Value. To learn how value classes affect copy operations, see Copying Objects in the MATLAB documentation.

Examples **Test That Actual Value Is Greater Than or Equal to Provided Floor Value**

Create a test case for interactive testing.

```
import matlab.unittest.TestCase
```

matlab.unittest.constraints.IsGreaterThanOrEqualTo

```
import matlab.unittest.constraints.IsGreaterThanOrEqualTo;
```

```
testCase = TestCase.forInteractiveUse;
```

Test that the actual value is greater than or equal to two.

```
actVal = 3;  
testCase.verifyThat(actVal, IsGreaterThanOrEqualTo(2));
```

Test that the actual value is greater than or equal to three.

```
testCase.verifyThat(actVal, IsGreaterThanOrEqualTo(3));
```

Interactive verification passed.

Test that each element in the actual value array is greater than or equal to four.

```
actVal = [5 6 7];  
testCase.verifyThat(actVal, IsGreaterThanOrEqualTo(4));
```

Interactive verification passed.

Test that each element in the actual value matrix is greater than or equal to four.

```
actVal = [1 2 3; 4 5 6];  
testCase.verifyThat(actVal, IsGreaterThanOrEqualTo(4));
```

Interactive verification failed.

```
-----  
Framework Diagnostic:  
-----
```

IsGreaterThanOrEqualTo failed.

--> Each element must be greater than or equal to the minimum value.

Failing Indices:

```
1      3      5
```

matlab.unittest.constraints.IsGreaterThanOrEqualTo

```
Actual Value:
      1      2      3
      4      5      6
Minimum Value (Inclusive):
      4
```

The matrix contains three elements that are greater than or equal to four.

Test that the actual value, 5, is greater than or equal to every element in an array.

```
testCase.verifyThat(5, IsGreaterThanOrEqualTo([1 2 3 5]));
```

Interactive verification passed.

Test that elements in the actual value array are greater than or equal to the corresponding floor values.

```
testCase.verifyThat([5 -3 0], IsGreaterThanOrEqualTo([4 -9 0]));
```

Interactive verification passed.

Repeat the test, this time negating the first actual value element.

```
testCase.verifyThat([-5 -3 0], IsGreaterThanOrEqualTo([4 -9 0]));
```

Interactive verification failed.

```
-----  
Framework Diagnostic:  
-----
```

IsGreaterThanOrEqualTo failed.

--> Each element must be greater than or equal to each corresponding element

Failing Indices:

1

```
Actual Value:
    -5    -3     0
Minimum Value (Inclusive):
     4    -9     0
```

The negated element is less than or equal to four.

See Also

[ge](#) | [IsGreaterThan](#) | [IsLessThanOrEqualTo](#) | [IsLessThan](#)

Concepts

matlab.unittest.constraints.IsEqualTo

Superclasses BooleanConstraint

Purpose General constraint to compare for equality

Description The IsEqualTo class creates a constraint that compares data for equality. The type of comparison it uses is governed by the data type of the expected value. First, the testing framework checks if the expected value is an object. This check is performed first because it is possible for the object to have overridden methods that are used in subsequent checks (e.g. `islogical`). The following list categorizes and describes the various tests.

Data Type	Equality Comparison Method
MATLAB & Java Objects	If the expected value is a MATLAB or Java object, the IsEqualTo constraint calls the <code>isequal</code> method on the expected value object. If <code>isequal</code> returns <code>false</code> and a supported tolerance is specified, the constraint checks the actual and expected values for equivalent class, size, and sparsity. If these checks fail, the constraint is not satisfied. If these checks pass, the constraint uses the tolerance in the comparison.
Logicals	If the expected value is a <code>logical</code> , the constraint checks the actual and expected values for equivalent sparsity. If the sparsity matches, the constraint compares the values with the <code>isequal</code> method. Otherwise, the constraint is not satisfied.
Numerics	If the expected value is <code>numeric</code> , the constraint checks the actual and expected values for equivalent class, size, and sparsity. If the all these checks match, the constraint uses the <code>isequaln</code> method for comparison. If <code>isequaln</code> returns <code>true</code> , the constraint is satisfied. If the complexity does not match or <code>isequaln</code> returns <code>false</code> , and a supported tolerance is supplied, the constraint uses the tolerance in the comparison. Otherwise, the constraint is not satisfied.

Data Type	Equality Comparison Method
Strings	If the expected value is a string, the constraint uses the <code>strcmp</code> function to check the actual and expected values for equality. However, if the <code>IgnoreCase</code> property is true, the strings are compared using <code>strcmpi</code> . If the <code>IgnoreWhitespace</code> is true, all whitespace characters are removed from the actual and expected strings before passing them to <code>strcmp</code> or <code>strcmpi</code> .
Structures	If the expected value is a struct, the constraint compares the field count of the actual and expected values. If not equal, the constraint is not satisfied. Otherwise, each field of the expected value struct must exist on the actual value struct. If any field names are different, the constraint is not satisfied. Then, the constraint recursively compares the fields in a depth first examination. The recursion continues until a fundamental data type is encountered (i.e. logical, numeric, string, or object), and then the values are compared as described above.
Cell Arrays	If the expected value is a cell array, the constraint checks the actual and expected values for size equality. If they are not equal in size, the constraint is not satisfied. Otherwise, each element of the array is recursively compared in a manner identical to fields in a structure, described above.

Construction

`IsEqualTo(expVal)` provides a general constraint to compare for equality.

`IsEqualTo(expVal,Name,Value)` provides a constraint with additional options specified by one or more `Name,Value` pair arguments. `Name` must appear inside single quotes (' '). You can specify several name-value pair arguments in any order as `Name1,Value1,...,NameN,ValueN`.

Input Arguments

expVal

The expected value that will be compared to the actual value.

Name-Value Pair Arguments

Specify optional comma-separated pairs of **Name**, **Value** arguments. **Name** is the argument name and **Value** is the corresponding value. **Name** must appear inside single quotes (' '). You can specify several name and value pair arguments in any order as **Name1**, **Value1**, ..., **NameN**, **ValueN**.

IgnoringCase

Indicator if the constraint is insensitive to case, specified as **false** or **true** (logical 0 or 1)

Default: false

IgnoringWhitespace

Indicator if the constraint is insensitive to whitespace, specified as **false** or **true** (logical 0 or 1)

Default: false

Using

Particular comparator to use for constraint construction, specified as a `matlab.unittest.constraints.Comparator` object

Default: (empty)

Within

Tolerance to use in constraint construction, specified as a `matlab.unittest.constraints.Tolerance` object

Default: (empty)

Properties

Comparator

Specific comparator used in construction of the constraint, specified as a `matlab.unittest.constraints.Comparator` object in the name-value pair argument, 'Using'.

Expected

The expected value that will be compared to the actual value specified in the `expVal` input argument.

IgnoreCase

Indicator if the constraint is insensitive to case, specified in the name-value pair argument, 'IgnoringCase'. This property applies at all levels of recursion, such as nested structures.

IgnoreWhitespace

Indicator if the constraint is insensitive to whitespace, specified in the name-value pair argument, 'IgnoringWhitespace'. This property applies at all levels of recursion, such as nested structures.

Tolerance

Specific tolerance used in construction of the constraint, specified as a `matlab.unittest.constraints.Tolerance` object in the name-value pair argument, 'Within'. This property applies at all levels of recursion, such as nested structures.

Copy Semantics

Value. To learn how value classes affect copy operations, see Copying Objects in the MATLAB documentation.

Examples

Test Numerics for Equality

Create a `TestCase` for interactive testing.

```
import matlab.unittest.TestCase;
```

matlab.unittest.constraints.IsEqualTo

```
import matlab.unittest.constraints.IsEqualTo;
import matlab.unittest.constraints.AbsoluteTolerance;
import matlab.unittest.constraints.RelativeTolerance;
```

```
testCase = TestCase.forInteractiveUse;
```

Verify that an actual value of 5 is equal to the expected value.

```
expVal = 5;
testCase.verifyThat(expVal, IsEqualTo(5));
```

```
Interactive verification passed.
```

Assume that the actual value is 4.95. Verify that the difference between the actual value and expected value is less than 0.09.

```
testCase.verifyThat(expVal, IsEqualTo(4.95, 'Within', AbsoluteTolerance(0.09)));
```

```
Interactive verification passed.
```

Assume that the actual value is 4.9. Verify that the difference between the actual and expected value is less than 1%.

```
testCase.verifyThat(expVal, IsEqualTo(4.9, 'Within', RelativeTolerance(0.01)));
```

```
Interactive verification failed.
```

```
-----
Framework Diagnostic:
-----
```

```
IsEqualTo failed.
```

```
--> NumericComparator failed.
```

```
    --> The values are not equal using "isequaln".
```

```
    --> RelativeTolerance failed.
```

```
        --> The value was not within relative tolerance.
```

```
            Tolerance Value:
```

```
                0.0100000000000000
```

```
Actual Value:
      5
Expected Value:
4.900000000000000
```

The two values differ by more than 1%.

Test Floating Point Calculation with Tolerance

Create a `TestCase` for interactive testing.

```
import matlab.unittest.TestCase;
import matlab.unittest.constraints.IsEqualTo;
import matlab.unittest.constraints.RelativeTolerance;
```

```
testCase = TestCase.forInteractiveUse;
```

Test that $0.1 \cdot 3 = 0.3$.

```
act = 0.1*3;
exp = 0.3;
testCase.verifyThat(act, IsEqualTo(exp))
```

Interactive verification failed.

```
-----
Framework Diagnostic:
-----
```

IsEqualTo failed.

--> NumericComparator failed.

--> The values are not equal using "isequaln".

```
Actual Value:
0.300000000000000
Expected Value:
0.300000000000000
```

This test fails due to round off error in floating point arithmetic.

matlab.unittest.constraints.IsEqualTo

Perform the comparison of floating point numbers using a tolerance.
Test that $0.1 * 3 = 0.3$ within a relative tolerance of $2 * \text{eps}$.

```
testCase.verifyThat(act, IsEqualTo(exp, ...  
    'Within', RelativeTolerance(2*eps)));
```

Interactive verification passed.

Test Strings for Equality

Create a TestCase for interactive testing.

```
import matlab.unittest.TestCase;  
import matlab.unittest.constraints.IsEqualTo;
```

```
testCase = TestCase.forInteractiveUse;
```

Verify that two strings are equal.

```
expVal = 'Hello';  
testCase.verifyThat(expVal, IsEqualTo('Hello'));
```

Interactive verification passed.

Change the case of the actual string and test for equality.

```
testCase.verifyThat(expVal, IsEqualTo('hello'));
```

Interactive verification failed.

```
-----  
Framework Diagnostic:  
-----
```

```
IsEqualTo failed.
```

```
--> StringComparator failed.
```

```
    --> The strings are not equal
```

```
Actual String:
```

```
    Hello
```

```
Expected String:  
    hello
```

Ignore case and test again.

```
testCase.verifyThat(expVal, IsEqualTo('hello', 'IgnoringCase', true));
```

```
Interactive verification passed.
```

Ignore whitespace and test two strings.

```
expVal = 'a bc';  
testCase.verifyThat(expVal, IsEqualTo('abc', 'IgnoringWhitespace', true));  
testCase.verifyThat(expVal, IsEqualTo('ab c', 'IgnoringWhitespace', true));
```

```
Interactive verification passed.  
Interactive verification passed.
```

Test Objects for Equality Using Comparator

Create a test case for interactive testing.

```
import matlab.unittest.TestCase;  
import matlab.unittest.constraints.IsEqualTo;  
import matlab.unittest.constraints.RelativeTolerance;  
import matlab.unittest.constraints.PublicPropertyComparator;
```

```
testCase = TestCase.forInteractiveUse;
```

Define actual and expected timeseries objects. Perturb one of the actual data points by 1%.

```
expected = timeseries(1:10);  
actual = expected;  
actual.Data(7) = 1.01*actual.Data(7);
```

Test that the actual and expected values are equal within a relative tolerance of 2%.

```
testCase.verifyThat(actual, IsEqualTo(expected, ...
```

matlab.unittest.constraints.IsEqualTo

```
'Within', RelativeTolerance(.02)));
```

```
Interactive verification failed.
```

```
-----  
Framework Diagnostic:  
-----
```

```
IsEqualTo failed.
```

```
--> ObjectComparator failed.
```

```
--> The objects are not equal using "isequal".
```

```
--> The tolerance does not support timeseries values so it was not used.
```

```
Actual Object:
```

```
timeseries
```

```
Common Properties:
```

```
    Name: 'unnamed'
```

```
    Time: [10x1 double]
```

```
    TimeInfo: [1x1 tsdata.timemetadadata]
```

```
    Data: [1x1x10 double]
```

```
    DataInfo: [1x1 tsdata.datametadadata]
```

```
More properties, Methods
```

```
Expected Object:
```

```
timeseries
```

```
Common Properties:
```

```
    Name: 'unnamed'
```

```
    Time: [10x1 double]
```

```
    TimeInfo: [1x1 tsdata.timemetadadata]
```

```
    Data: [1x1x10 double]
```

```
    DataInfo: [1x1 tsdata.datametadadata]
```

```
More properties, Methods
```

Use the `PublicPropertyComparator` in the construction of the constraint.

```
testCase.verifyThat(actual, IsEqualTo(expected,...  
    'Within', RelativeTolerance(.02),...  
    'Using', PublicPropertyComparator.supportingAllValues));
```

```
Interactive verification passed.
```

The test passes because the `PublicPropertyComparator` compares each public property individually instead of comparing the object all at once. In the former test, the `ObjectComparator` is used on the `timeseries` object, and therefore relies on the `isequal` method of the `timeseries` class. Due to the perturbation in the actual `timeseries`, `isequal` returns `false`. The comparator does not apply the tolerance because the double-valued tolerance cannot apply directly to the `timeseries` object. In the latter test, the comparator applies the tolerance to each public property that contains double-valued data.

See Also

```
matlab.unittest.constraints.Constraint |  
matlab.unittest.constraints.Tolerance
```

Concepts

matlab.unittest.constraints.IsInstanceOf

Superclasses BooleanConstraint

Purpose Constraint specifying inclusion in given class hierarchy

Construction `IsInstanceOf(class)` provides a constraint specifying inclusion in a given class hierarchy. The constraint is satisfied if the actual value instance passes the “isa” relationship with `class` .

Input Arguments

class

Class name that the actual value must derive from or be an instance of to satisfy the constraint, specified as a fully qualified class name string or a `meta.class` instance.

Properties

Class

Class name that the actual value must derive from or be an instance of to satisfy the constraint. Set this property through the constructor via the `class` input argument.

Copy Semantics

Value. To learn how value classes affect copy operations, see Copying Objects in the MATLAB documentation.

Examples

Test That Actual Value Is Instance of Specified Class

Create a test case for interactive testing.

```
import matlab.unittest.TestCase
import matlab.unittest.constraints.IsInstanceOf;
```

```
testCase = TestCase.forInteractiveUse;
```

Verify that the actual value, 5, is an instance of the double class.

```
testCase.verifyThat(5, IsInstanceOf('double'));
```

Interactive verification passed.

Repeat the test using an instance of `meta.class` instead of a string.

```
testCase.verifyThat(5, IsInstanceOf(?double));
```

Interactive verification passed.

Assert that zero is an instance of the logical class.

```
testCase.assertThat(0, IsInstanceOf('logical'));
```

Interactive assertion failed.

```
-----  
Framework Diagnostic:  
-----
```

```
IsInstanceOf failed.
```

```
--> The value must be an instance of the expected type.
```

```
    Actual Class:  
        double  
    Expected Type:  
        logical
```

```
Actual Value:
```

```
    0
```

```
Assertion failed.
```

Verify that `@sin` is a function handle.

```
testCase.verifyThat(@sin, IsInstanceOf(?function_handle));
```

Interactive verification passed.

Verify that `name` is an instance of the char class.

```
name = 42;
```

```
testCase.verifyThat(name, IsInstanceOf('char'));
```

matlab.unittest.constraints.IsInstanceOf

```
Interactive verification failed.

-----
Framework Diagnostic:
-----
IsInstanceOf failed.
--> The value must be an instance of the expected type.

    Actual Class:
           double
    Expected Type:
           char

Actual Value:
           42
```

Test That Derived Class Is Instance of Specified Class

In a file in your working folder, create a class, `DerivedExample`, that inherits from the `handle` class.

```
classdef DerivedExample < handle
end
```

At the command prompt, create a test case for interactive testing.

```
import matlab.unittest.TestCase
import matlab.unittest.constraints.IsInstanceOf;
```

```
testCase = TestCase.forInteractiveUse;
```

Verify that an instance of the `DerivedExample` class is an instance of a `handle`.

```
exObj = DerivedExample;
testCase.verifyThat(exObj, IsInstanceOf(?handle));
```

```
Interactive verification passed.
```

Even though `exObj` is not an instance of the `handle` class, the verification passes because it derives from the `handle` class.

See Also

[IsOfClass](#) | [isa](#)

Concepts

matlab.unittest.constraints.IsLessThan

Superclasses Constraint

Purpose Constraint specifying value less than another value

Construction `IsLessThan(ceilVal)` creates a constraint specifying that an actual value less is than another value. The constraint is satisfied if the actual value array is less than the specified ceiling value, `ceilVal`. The actual value is less than `ceilVal` only if the result of the expression `actual < ceilVal` is nonempty and all values are true.

Input Arguments

ceilVal

Smallest value that fails the constraint.

Properties **CeilingValue**

Smallest value that fails the constraint. Set this property through the constructor via the `ceilVal` input argument.

Methods

<code>and</code>	Form logical conjunction of constraints
<code>or</code>	Form logical disjunction of constraints

Copy Semantics Value. To learn how value classes affect copy operations, see Copying Objects in the MATLAB documentation.

Examples **Test That Actual Value Is Less Than Provided Ceiling Value**

Create a test case for interactive testing.

```
import matlab.unittest.TestCase
import matlab.unittest.constraints.IsLessThan;
```

```
testCase = TestCase.forInteractiveUse;
```

Test that the actual value is less than four.

```
actVal = 3;  
testCase.verifyThat(actVal, IsLessThan(4));
```

Interactive verification passed.

Test that the actual value is less than three.

```
testCase.verifyThat(actVal, IsLessThan(3));
```

Interactive verification failed.

```
-----  
Framework Diagnostic:  
-----  
IsLessThan failed.  
--> The value must be less than the maximum value.
```

```
Actual Value:  
    3  
Maximum Value (Exclusive):  
    3
```

The actual value is equal to, not less than, three.

Test that each element in the actual value array is less than four.

```
actVal = [1 2 3];  
testCase.verifyThat(actVal, IsLessThan(4));
```

Interactive verification passed.

Test that each element in the actual value matrix is less than four.

```
actVal = [1 2 3; 4 5 6];  
testCase.verifyThat(actVal, IsLessThan(4));
```

matlab.unittest.constraints.IsLessThan

Interactive verification failed.

Framework Diagnostic:

IsLessThan failed.

--> Each element must be less than the maximum value.

Failing Indices:

2 4 6

Actual Value:

1 2 3
4 5 6

Maximum Value (Exclusive):

4

The matrix contains three elements that are greater than or equal to four.

Test that the actual value, 0, is less than every element in an array.

```
testCase.verifyThat(0, IsLessThan([1 2 3]));
```

Interactive verification passed.

Test that elements in the actual value array are less than the corresponding ceiling values.

```
testCase.verifyThat([4 -9 0], IsLessThan([5 -3 2]));
```

Interactive verification passed.

Repeat the test, this time negating the second actual value element.

```
testCase.verifyThat([4 9 0], IsLessThan([5 -3 2]));
```

Interactive verification failed.

```
-----  
Framework Diagnostic:  
-----  
IsLessThan failed.  
--> Each element must be less than each corresponding element of the r
```

```
    Failing Indices:  
          2
```

```
Actual Value:  
    4     9     0  
Maximum Value (Exclusive):  
    5    -3     2
```

The negated element is greater than -3.

See Also

[lt](#) | [IsGreaterThanOrEqualTo](#) | [IsLessThanOrEqualTo](#) | [IsGreaterThan](#)

Concepts

matlab.unittest.constraints.IsLessThanOrEqualTo

Superclasses Constraint

Purpose Constraint specifying value less than or equal to another value

Construction `IsLessThanOrEqualTo(ceilVal)` creates a constraint specifying that an actual value is less than or equal to another value. The constraint is satisfied if the actual value array is less than or equal to the specified ceiling value, `ceilVal`. The actual value is less than or equal to `ceilVal` only if the result of the expression `actual <= ceilVal` is nonempty and all values are true.

Input Arguments

ceilVal

Maximum value to satisfy the constraint.

Properties **CeilingValue**

Maximum value to satisfy the constraint. Set this property through the constructor via the `ceilVal` input argument.

Methods

<code>and</code>	Form logical conjunction of constraints
<code>or</code>	Form logical disjunction of constraints

Copy Semantics Value. To learn how value classes affect copy operations, see Copying Objects in the MATLAB documentation.

Examples **Test That Actual Value Is Less Than or Equal to Provided Ceiling Value**

Create a test case for interactive testing.

```
import matlab.unittest.TestCase
```

matlab.unittest.constraints.IsLessThanOrEqualTo

```
import matlab.unittest.constraints.IsLessThanOrEqualTo;
```

```
testCase = TestCase.forInteractiveUse;
```

Test that the actual value is less than or equal to four.

```
actVal = 3;  
testCase.verifyThat(actVal, IsLessThanOrEqualTo(4));
```

```
Interactive verification passed.
```

Test that the actual value is less than or equal to three.

```
testCase.verifyThat(actVal, IsLessThanOrEqualTo(3));
```

```
Interactive verification passed.
```

Test that each element in the actual value array is less than or equal to four.

```
actVal = [1 2 3 4];  
testCase.verifyThat(actVal, IsLessThanOrEqualTo(4));
```

```
Interactive verification passed.
```

Test that each element in the actual value matrix is less than or equal to four.

```
actVal = [1 2 3; 4 5 6];  
testCase.verifyThat(actVal, IsLessThanOrEqualTo(4));
```

```
Interactive verification failed.
```

```
-----  
Framework Diagnostic:  
-----
```

```
IsLessThanOrEqualTo failed.
```

```
--> Each element must be less than or equal to the maximum value.
```

matlab.unittest.constraints.IsLessThanOrEqualTo

```
Failing Indices:  
      4      6
```

```
Actual Value:  
      1      2      3  
      4      5      6  
Maximum Value (Inclusive):  
      4
```

The matrix contains two elements that are greater than four.

Test that the actual value, 1, is less than or equal to every element in an array.

```
testCase.verifyThat(1, IsLessThanOrEqualTo([1 2 3]));
```

Interactive verification passed.

Test that elements in the actual value array are less than the corresponding ceiling values.

```
testCase.verifyThat([4 -9 2], IsLessThanOrEqualTo([5 -3 2]));
```

Interactive verification passed.

Repeat the test, this time negating the second actual value element.

```
testCase.verifyThat([4 9 2], IsLessThanOrEqualTo([5 -3 2]));
```

Interactive verification failed.

```
-----  
Framework Diagnostic:  
-----
```

IsLessThanOrEqualTo failed.

--> Each element must be less than or equal to each corresponding element

```
Failing Indices:  
      2
```

Actual Value:

4 9 2

Maximum Value (Inclusive):

5 -3 2

The negated element is greater than -3.

See Also

[le](#) | [IsGreaterThanOrEqualTo](#) | [IsLessThan](#) | [IsGreaterThan](#)

Concepts

matlab.unittest.constraints.IsOfClass

Superclasses BooleanConstraint

Purpose Constraint specifying class type

Construction `IsOfClass(class)` provides a constraint specifying the class type. The constraint is satisfied if the actual value is the same class as `class`. The constraint is not satisfied if the actual value derives from `class`.

Input Arguments

class

Class name that must be matched by the actual value to satisfy the constraint, specified as a fully qualified class name string or a `meta.class` instance.

Properties

Class

Class name that must be matched by the actual value to satisfy the constraint. Set this property through the constructor via the `class` input argument.

Copy Semantics

Value. To learn how value classes affect copy operations, see Copying Objects in the MATLAB documentation.

Examples

Test That Actual Value Class Is Specified Class

Create a test case for interactive testing.

```
import matlab.unittest.TestCase
import matlab.unittest.constraints.IsOfClass;
```

```
testCase = TestCase.forInteractiveUse;
```

Verify that the actual value, 5, is a double.

```
testCase.verifyThat(5, IsOfClass('double'));
```

Interactive verification passed.

Repeat the test using an instance of `meta.class` instead of a string.

```
testCase.verifyThat(5, IsOfClass(?double));
```

Interactive verification passed.

Assert that zero is an instance of the logical class.

```
testCase.assertThat(0, IsOfClass('logical'));
```

Interactive assertion failed.

```
-----  
Framework Diagnostic:  
-----  
IsOfClass failed.  
--> The value's class is incorrect.
```

```
    Actual Class:  
        double  
    Expected Class:  
        logical
```

```
Actual Value:  
    0  
Assertion failed.
```

Verify that `@sin` is a function handle.

```
testCase.verifyThat(@sin, IsOfClass(?function_handle));
```

Interactive verification passed.

Verify that `name` is an instance of the char class.

```
name = 42;  
testCase.verifyThat(name, IsOfClass('char'));
```

matlab.unittest.constraints.IsOfClass

```
Interactive verification failed.  
  
-----  
Framework Diagnostic:  
-----  
IsOfClass failed.  
--> The value's class is incorrect.
```

```
    Actual Class:  
        double  
    Expected Class:  
        char
```

```
Actual Value:  
    42
```

Test That Derived Class Is Instance of Specified Class

In a file in your working folder, create a class, `DerivedExample`, that inherits from the `handle` class.

```
classdef DerivedExample < handle  
end
```

At the command prompt, create a test case for interactive testing.

```
import matlab.unittest.TestCase  
import matlab.unittest.constraints.IsOfClass;
```

```
testCase = TestCase.forInteractiveUse;
```

Verify that an instance of the `DerivedExample` class is an instance of a `handle`.

```
exObj = DerivedExample;  
testCase.verifyThat(exObj, IsOfClass(?handle));
```

```
Interactive verification failed.
```



```
-----  
Framework Diagnostic:  
-----  
IsOfClass failed.  
--> The value's class is incorrect.  
  
    Actual Class:  
        DerivedExample  
    Expected Class:  
        handle  
  
Actual Value:  
    DerivedExample with no properties.
```

Even though `exObj` derives from the `handle` class, it is not an instance of the `handle` class.

Verify that an instance of the `DerivedExample` class is an instance of a `DerivedExample`.

```
testCase.verifyThat(exObj, IsOfClass(?DerivedExample));
```

```
Interactive verification passed.
```

See Also

`IsInstanceOf` | `class`

Concepts

matlab.unittest.constraints.IsReal

Superclasses	BooleanConstraint
Purpose	Constraint specifying real valued array
Construction	IsReal provides a constraint specifying a real valued array. This constraint is satisfied only if the actual value contains only real values.
Copy Semantics	Value. To learn how value classes affect copy operations, see Copying Objects in the MATLAB documentation.

Examples **Test That Actual Value Array Is Real Valued**

Create a test case for interactive testing.

```
import matlab.unittest.TestCase
import matlab.unittest.constraints.IsReal;
```

```
testCase = TestCase.forInteractiveUse;
```

Verify that the values 5 and 5+0i are real.

```
testCase.verifyThat(5, IsReal);
testCase.verifyThat(5+0i, IsReal);
```

```
Interactive verification passed.
Interactive verification passed.
```

Test if the imaginary number is real.

```
testCase.verifyThat(sqrt(-1), IsReal);
```

```
Interactive verification failed.
```

```
-----
Framework Diagnostic:
-----
IsReal failed.
--> The value must be real.
```

```
Actual Value:  
0.0000000000000000 + 1.0000000000000000i
```

The actual value is imaginary.

Assert that an array contains only real values.

```
testCase.assertThat([0 1 1 2 3 5 8 13], IsReal);
```

```
Interactive assertion passed.
```

Test that the array, `arr`, is real.

```
arr = [NaN -Inf];  
testCase.verifyThat(arr, IsReal);
```

```
Interactive verification passed.
```

Multiply the array by a complex number and test that the values are not real.

```
testCase.verifyThat(42i*arr, ~IsReal);
```

```
Interactive verification passed.
```

See Also

```
isreal
```

Concepts

matlab.unittest.constraints.IsSameHandleAs

Superclasses	BooleanConstraint
Purpose	Constraint specifying handle instance same as another
Construction	<p>IsSameHandle(h) provides a constraint specifying a handle instance or group of instances is same as another.</p> <p>The constraint is satisfied only if each element of the actual value is the same instance as each corresponding element of h.</p>
Input Arguments	<p>h</p> <p>handle object or array of handle objects. The actual value array passed to the qualification must be the same size as h.</p>
Copy Semantics	Value. To learn how value classes affect copy operations, see Copying Objects in the MATLAB documentation.

Examples

Test Handles for Equality

In a file in your working folder, create the following handle class for interactive testing.

```
classdef ExampleHandle < handle
end
```

At the command prompt, create a test case for interactive testing.

```
import matlab.unittest.TestCase;
import matlab.unittest.constraints.IsSameHandleAs;

testCase = TestCase.forInteractiveUse;
```

Instantiate two handles.

```
h1 = ExampleHandle;
h2 = ExampleHandle;
```

Verify that the handle, h1, is the same as h1.

```
testCase.verifyThat(h1, IsSameHandleAs(h1));
```

Interactive verification passed.

Test that h1 is the same handle instance as h2.

```
testCase.verifyThat(h1, IsSameHandleAs(h2));
```

Interactive verification failed.

```
-----  
Framework Diagnostic:  
-----  
IsSameHandleAs failed.  
--> Values do not refer to the same handle.
```

Actual Value:

ExampleHandle with no properties.

Expected Handle Object:

ExampleHandle with no properties.

Test that two arrays of handles are the same instances.

```
expArr = [h1 h2 h1];
```

```
actArr = [h1 h2 h1];
```

```
testCase.verifyThat(expArr, IsSameHandleAs(actArr));
```

Interactive verification passed.

The arrays satisfy the constraint even though the elements within a particular array are not the same instance as each other.

Verify that the constraint is not satisfied if it expects a single handle and the actual value is an array of the same instances.

```
testCase.verifyThat([h1 h1], IsSameHandleAs(h1));
```

matlab.unittest.constraints.IsSameHandleAs

```
Interactive verification failed.
```

```
-----  
Framework Diagnostic:  
-----
```

```
IsSameHandleAs failed.  
--> Sizes do not match.  
    Actual Value Size           : [1  2]  
    Expected Handle Object Size : [1  1]
```

```
Actual Value:  
    1x2 ExampleHandle array with no properties.  
Expected Handle Object:  
    ExampleHandle with no properties.
```

Similarly, the constraint is not satisfied a single handle instance if it expects an array of handles.

```
testCase.verifyThat(h2, IsSameHandleAs([h2 h2]));
```

```
Interactive verification failed.
```

```
-----  
Framework Diagnostic:  
-----
```

```
IsSameHandleAs failed.  
--> Sizes do not match.  
    Actual Value Size           : [1  1]  
    Expected Handle Object Size : [1  2]
```

```
Actual Value:  
    ExampleHandle with no properties.  
Expected Handle Object:  
    1x2 ExampleHandle array with no properties.
```

See Also

[eq](#) | [handle](#) | [IsEqualTo](#)

Concepts

matlab.unittest.constraints.IsSparse

Superclasses BooleanConstraint

Purpose Constraint specifying sparse array

Construction IsSparse creates a constraint specifying a sparse array. This constraint is satisfied only when the actual value is sparse.

Copy Semantics Value. To learn how value classes affect copy operations, see Copying Objects in the MATLAB documentation.

Examples **Test That Actual Value Array Is Sparse**

Create a test case for interactive testing.

```
import matlab.unittest.TestCase
import matlab.unittest.constraints.IsSparse;
```

```
testCase = TestCase.forInteractiveUse;
```

Create an identity matrix, and test if it is sparse.

```
F = eye(7);
testCase.verifyThat(F, IsSparse);
```

```
testCase.verifyThat(F, IsSparse);
Interactive verification failed.
```

```
-----
Framework Diagnostic:
```

```
-----
IsSparse failed.
--> The value must be sparse.
```

Actual Value:

```
    1    0    0    0    0    0    0
    0    1    0    0    0    0    0
    0    0    1    0    0    0    0
```



```
0  0  0  1  0  0  0
0  0  0  0  1  0  0
0  0  0  0  0  1  0
0  0  0  0  0  0  1
```

The matrix, F, is a full matrix.

Convert F to a sparse matrix and retest for sparsity.

```
S = sparse(F);
testCase.verifyThat(S, IsSparse);
```

Interactive verification passed.

See Also

`issparse`

Concepts

matlab.unittest.constraints.IsSubstringOf

Superclasses BooleanConstraint

Purpose Constraint specifying substring of another string

Construction `IsSubstringOf(superstring)` creates a constraint specifying a substring of another string. The constraint is satisfied only if the actual value is contained within an expected string, `superstring`.

`IsSubstringOf(superstring,Name,Value)` provides a constraint with additional options specified by one or more `Name,Value` pair arguments. `Name` must appear inside single quotes (' '). You can specify several name-value pair arguments in any order as `Name1,Value1,...,NameN,ValueN`.

Input Arguments

superstring

Text that contains the actual value, specified as a string. `superstring` can include newline characters.

Name-Value Pair Arguments

Specify optional comma-separated pairs of `Name,Value` arguments. `Name` is the argument name and `Value` is the corresponding value. `Name` must appear inside single quotes (' '). You can specify several name and value pair arguments in any order as `Name1,Value1,...,NameN,ValueN`.

IgnoringCase

Indicator if the constraint is insensitive to case, specified as `false` or `true` (logical 0 or 1)

Default: `false`

IgnoringWhitespace

Indicator if the constraint is insensitive to whitespace, specified as `false` or `true` (logical 0 or 1)

Default: false

Properties

IgnoreCase

Indicator if the constraint is insensitive to case, specified in the name-value pair argument, 'IgnoringCase'. This property applies at all levels of recursion, such as nested structures.

IgnoreWhitespace

Indicator if the constraint is insensitive to whitespace, specified in the name-value pair argument, 'IgnoringWhitespace'. This property applies at all levels of recursion, such as nested structures.

Superstring

String that includes the actual value, specified in the input argument, `superstring`.

Copy Semantics

Value. To learn how value classes affect copy operations, see Copying Objects in the MATLAB documentation.

Examples

Test That Actual Value Is Substring of Specified String

Create a test case for interactive testing.

```
import matlab.unittest.TestCase
import matlab.unittest.constraints.IsSubstringOf;
```

```
testCase = TestCase.forInteractiveUse;
```

Define the actual value string.

```
S = 'This Is One Long String';
```

Test that the actual value string, 'One', is contained in S.

```
testCase.verifyThat('One', IsSubstringOf(S));
```

matlab.unittest.constraints.IsSubstringOf

Interactive verification passed.

Test that the actual value string, 'long', is contained in S.

```
testCase.verifyThat('long', IsSubstringOf(S));
```

Interactive verification failed.

Framework Diagnostic:

IsSubstringOf failed.

--> The string must be found within the superstring.

Actual String:

long

Expected Superstring:

This Is One Long String

By default, the `IsSubstringOf` constraint is case sensitive.

Repeat the test ignoring case.

```
testCase.verifyThat('long', IsSubstringOf(S, ...  
    'IgnoringCase', true));
```

Interactive verification passed.

Test that the actual value string, 'thisisone', is contained in S. For the test to pass, configure the constraint to ignore whitespace and case.

```
testCase.verifyThat('thisisone', IsSubstringOf(S, ...  
    'IgnoringCase', true, 'IgnoringWhitespace', true));
```

Interactive verification passed.

Assert that the actual value string, 'longer', is not contained in S.

```
testCase.assertThat('Longer', ~IsSubstringOf(S));
```

Interactive assertion passed.

See Also

[ContainsSubstring](#) | [EndsWithSubstring](#) | [StartsWithSubstring](#)
| [Matches](#)

Concepts

matlab.unittest.constraints.IssuesNoWarnings

Superclasses Constraint

Purpose Constraint specifying function that issues no warnings

Construction `outConstObj = IssuesNoWarnings` creates a constraint, `outConstObj`, specifying a function that issues no warnings when the testing framework invokes it. The constraint is satisfied if no warnings are issued when the testing framework invokes the function.

`outConstObj = IssuesNoWarnings('WhenNargoutIs', numOutputs)` creates a constraint that can determine if the actual value is a function handle that issues no warnings when the testing framework invokes it with a particular number of output arguments, `numOutputs`.

Input Arguments

numOutputs

Number of outputs the constraint requests when invoking the function handle, specified as a non-negative, real, scalar integer.

Default: 0

Properties **FunctionOutputs**

Output arguments produced at invocation of the supplied function handle, specified as a cell array. This property provides access to output arguments. It is read only and the testing framework sets it when it invokes the function handle. The number of outputs is determined by the `Nargout` property.

Nargout

Number of output arguments the instance uses when executing functions. Set this property through the constructor via the `numOutputs` input argument.

Copy Semantics Handle. To learn how handle classes affect copy operations, see Copying Objects in the MATLAB documentation.

Examples

Instantiate IssuesNoWarnings Constraint

Create a test case for interactive testing.

```
import matlab.unittest.TestCase;
import matlab.unittest.constraints.IssuesNoWarnings;
```

```
testCase = TestCase.forInteractiveUse;
```

Verify that a call to true does not result in any warning.

```
testCase.verifyThat(@true, IssuesNoWarnings);
```

```
Interactive verification passed.
```

Verify that a call to size with an empty array does not result in any warning. Examine the output arguments.

```
issuesNoWarningsConstraint = IssuesNoWarnings('WhenNargoutIs', 2);
testCase.verifyThat(@( ) size([]), issuesNoWarningsConstraint);
[actualOut1, actualOut2] = issuesNoWarningsConstraint.FunctionOutputs;
```

```
Interactive verification passed.
```

Verify that the constraint is not satisfied if the actual value is not a function handle.

```
testCase.verifyThat(5, IssuesNoWarnings);
```

```
Interactive verification failed.
```

```
-----
Framework Diagnostic:
-----
```

```
IssuesNoWarnings failed.
```

```
--> The value must be an instance of the expected type.
```

```
Actual Class:
double
```

matlab.unittest.constraints.IssuesNoWarnings

```
Expected Type:  
    function_handle
```

```
Actual Value:  
    5
```

Verify that the constraint is not satisfied if the actual value results in a warning.

```
testCase.verifyThat(@() warning('some:id', 'Message'), IssuesNoWarnings);
```

```
Warning: Message
```

```
> In @()warning('some:id','Message')  
  In FunctionHandleConstraint>FunctionHandleConstraint.invoke at 39  
  In WarningQualificationConstraint>WarningQualificationConstraint.invoke  
  In IssuesNoWarnings>IssuesNoWarnings.issuesNoWarnings at 132  
  In IssuesNoWarnings>IssuesNoWarnings.satisfiedBy at 83  
  In QualificationDelegate>QualificationDelegate.qualifyThat at 58  
  In Verifiable>Verifiable.verifyThat at 228  
Interactive verification failed.
```

```
-----  
Framework Diagnostic:  
-----  
IssuesNoWarnings failed.  
--> The function issued warnings.
```

```
Warnings Issued:  
    some:id
```

```
Evaluated Function:  
    @()warning('some:id','Message')
```

See Also

```
matlab.unittest.constraints.Constraint |  
matlab.unittest.constraints.IssuesWarnings |  
matlab.unittest.constraints.Throws | warning
```

Concepts

matlab.unittest.constraints.IssuesWarnings

Superclasses Constraint

Purpose Constraint specifying function that issues expected warning profile

Description The IssuesWarnings class creates a constraint that issues an expected warning profile. The constraint is satisfied only if the actual value is a function handle that issues a specific set of warnings. You specify warnings using warning identifiers.

By default, the constraint only confirms that when the testing framework invokes the function handle, MATLAB issues the specified set of warnings. It ignores the number of times the warnings are issued, in what order they are issued, and whether or not any unspecified warnings are issued. However, you can set parameters to respect the order, the count, and the warning set. Alternatively, you can specify the exact warning profile for comparison.

Construction `outConstObj = IssuesWarnings(warnArr)` creates a constraint, `outConstObj`, specifying a function that issues expected warnings, `warnArr`.

`outConstObj = IssuesWarnings(expVal,Name,Value)` creates a constraint with additional options specified by one or more `Name,Value` pair arguments. `Name` must appear inside single quotes (`'`). You can specify several name-value pair arguments in any order as `Name1,Value1,...,NameN,ValueN`.

Input Arguments

warnArr

Warning identifiers expected when the testing framework invokes the function handle, specified as a cell array of warning identifiers. If `warnArr` is empty, the constructor throws an `MException`.

Name-Value Pair Arguments

Specify optional comma-separated pairs of `Name,Value` arguments. `Name` is the argument name and `Value` is the corresponding

value. Name must appear inside single quotes (' '). You can specify several name and value pair arguments in any order as Name1,Value1,...,NameN,ValueN.

Exactly

Indicator if the value is a function handle that must issue a warning profile that is an exact match, specified as `false` or `true` (logical 0 or 1). When this value is `false`, the instance relies on specification of other parameters and default instance behavior to determine the strictness of its comparison. When set to `true`, the instance requires the warning profile to be exactly the same as the specified warning profile.

Default: `false`

RespectingCount

Indicator whether to respect element counts, specified as `false` or `true` (logical 0 or 1). When this value is `false`, the instance is insensitive to the number of occurrences of members and ignores their frequency. When set to `true`, the instance is sensitive to the total number of set members. This means that, in addition to ensuring that all of the specified warnings are issued, this instance is not satisfied if the number of times that a particular warning issues differs from the number of times that warning is specified in `warnArr`.

Default: `false`

RespectingOrder

Indicator whether to respect the order of elements, specified as `false` or `true` (logical 0 or 1). When this value is `false`, the instance is insensitive to the order of the set members. When set to `true`, the instance is sensitive to the order of the set members. This means that this instance is not satisfied if the order of the

matlab.unittest.constraints.IssuesWarnings

issued warnings differs from the order the warnings are specified in `warnArr`.

The order of a given set of warnings is determined by trimming the warning profiles to a profile with no repeated adjacent warnings. For example, the warning profile `{id:A, id:A, id:B, id:C, id:C, id:C, id:A, id:A, id:A}` is trimmed to `{id:A, id:B, id:C, id:A}`.

When this constraint respects order, the order of the warnings that are issued and expected must match the order of the expected warning profile. Warnings issued that are not listed in `warnArr` are ignored when determining order.

Default: `false`

RespectingSet

Indicator whether to respect set elements, specified as `false` or `true` (logical 0 or 1). When this value is `false`, the instance ignores additional set members. When set to `true`, the instance is sensitive to additional set members. This means that, in addition to ensuring that all of the specified warnings are issued, this instance is not satisfied if any extra, unspecified warnings are issued.

Default: `false`

WhenNargoutIs

Number of outputs the constraint should request when invoking the function handle, specified as a non-negative, real, scalar integer.

Default: `0`

Properties

Exact

Indicator of whether the constraint performs exact comparisons. Set this property through the constructor via the name-value pair argument, 'Exactly'.

ExpectedWarnings

Expected warning identifiers. Set this read-only property through the constructor via the warnArr input argument.

FunctionOutputs

Output arguments produced at invocation of the supplied function handle, specified as a cell array. This property provides access to output arguments. It is read only and the testing framework sets it when it invokes the function handle. The number of outputs is determined by the Nargout property.

Nargout

Number of output arguments the instance uses when it executes functions. Set this property through the constructor via the name-value pair argument, 'WhenNargoutIs'.

RespectCount

Indicator if the constraint respects the element counts, specified through the constructor via the name-value pair argument, 'RespectingCount'.

RespectOrder

Indicator if the constraint respects the order of elements, specified through the constructor via the name-value pair argument, 'RespectingOrder'.

RespectSet

Indicator if the constraint respects set elements, specified through the constructor via the name-value pair argument, 'RespectingSet'.

matlab.unittest.constraints.IssuesWarnings

Copy Semantics

Handle. To learn how handle classes affect copy operations, see Copying Objects in the MATLAB documentation.

Examples

Instantiate IssuesWarnings Constraint

Create a test case for interactive testing.

```
import matlab.unittest.TestCase;
import matlab.unittest.constraints.IssuesWarnings;
```

```
testCase = TestCase.forInteractiveUse;
```

Create a helper anonymous function for use in this example. Create several warning identifiers.

```
issueWarnings = @(idCell) cellfun(@(id) warning(id,'Message'), idCell);
firstID = 'first:id';
secondID = 'second:id';
thirdID = 'third:id';
```

Verify that the helper function issues a particular warning.

```
testCase.verifyThat(@( ) issueWarnings({firstID}),...
    IssuesWarnings({firstID}));
```

```
Interactive verification passed.
```

Verify the function issues a warning ignoring count, warning set, and order.

```
testCase.verifyThat(@( ) issueWarnings({firstID, thirdID, secondID,...
    firstID}), IssuesWarnings({secondID, firstID}));
```

```
Interactive verification passed.
```

Verify the function issues a warning while respecting the warning set.

```
testCase.verifyThat(@( ) issueWarnings({firstID, thirdID, secondID,...
    firstID}), IssuesWarnings({firstID, secondID, thirdID}, ...
```

```
'RespectingSet', true));
```

Interactive verification passed.

Verify the function issues a warning while respecting the warning count.

```
testCase.verifyThat(@( ) issueWarnings({secondID, firstID, thirdID,...  
    secondID}), IssuesWarnings({firstID, secondID, secondID}, ...  
    'RespectingCount', true));
```

Interactive verification passed.

Verify the function issues a warning while respecting the warning order.

```
testCase.verifyThat(@( ) issueWarnings({firstID, secondID, secondID,..  
    thirdID}), IssuesWarnings({firstID, secondID}, 'RespectingOrder',
```

Interactive verification passed.

Verify the function issues an exact match to the expected warning profile.

```
testCase.verifyThat(@( ) issueWarnings({firstID, secondID, secondID,..  
    thirdID}), IssuesWarnings({firstID, secondID, secondID, thirdID},  
    'Exactly', true));
```

Interactive verification passed.

Verify that the constraint is not satisfied if the actual value is not a function handle.

```
testCase.verifyThat(5, IssuesWarnings({firstID}));
```

Interactive verification failed.

```
-----  
Framework Diagnostic:
```

```
-----  
IssuesWarnings failed.
```

matlab.unittest.constraints.IssuesWarnings

--> The value must be an instance of the expected type.

```
Actual Class:
    double
Expected Type:
    function_handle
```

```
Actual Value:
    5
```

Verify that the constraint is not satisfied if the function does not issue a warning.

```
testCase.verifyThat(@rand, IssuesWarnings({firstID}));
```

Interactive verification failed.

```
-----
Framework Diagnostic:
-----
```

IssuesWarnings failed.

--> The function handle did not issue a correct warning profile.

The expected warning profile ignores:

```
Set
Count
Order
```

--> The function handle did not issue any warnings.

```
Expected Warning Profile:
    first:id
```

```
Evaluated Function:
    @rand
```

Verify that the constraint is not satisfied if the function issues a non-specified warning identifier.

```
testCase.verifyThat(@( ) issueWarnings({firstID}), IssuesWarnings({secondID}));
```

matlab.unittest.constraints.IssuesWarnings

```
Warning: Message
> In @(id)warning(id,'Message')
   In @(idCell)cellfun(@(id)warning(id,'Message'),idCell)
   In @()issueWarnings({firstID})
   In FunctionHandleConstraint>FunctionHandleConstraint.invoke at 39
   In WarningQualificationConstraint>WarningQualificationConstraint.invoke at 39
   In IssuesWarnings>IssuesWarnings.invoke at 409
   In IssuesWarnings>IssuesWarnings.issuesExpectedWarnings at 456
   In IssuesWarnings>IssuesWarnings.satisfiedBy at 242
   In QualificationDelegate>QualificationDelegate.qualifyThat at 58
   In Verifiable>Verifiable.verifyThat at 228
Interactive verification failed.
```

```
-----
Framework Diagnostic:
```

```
-----
IssuesWarnings failed.
```

```
--> The function handle did not issue a correct warning profile.
```

```
    The expected warning profile ignores:
```

```
        Set
```

```
        Count
```

```
        Order
```

```
--> The function handle did not issue the correct warnings.
```

```
    Missing Warnings:
```

```
        second:id
```

```
    Actual Warning Profile:
```

```
        first:id
```

```
    Expected Warning Profile:
```

```
        second:id
```

```
Evaluated Function:
```

```
    @()issueWarnings({firstID})
```

Consider the following actual value and warning array.

matlab.unittest.constraints.IssuesWarnings

```
actVal = @() issueWarnings({firstID, firstID, secondID, firstID});  
warnArr = {firstID, secondID, firstID, firstID};
```

Test whether the warning array is exactly the same as the expected array.

```
testCase.verifyThat(actVal, IssuesWarnings(warnArr, 'Exactly', true));
```

Warning: Message

```
> In @(id)warning(id,'Message')  
  In @(idCell)cellfun(@(id)warning(id,'Message'),idCell)  
  In @()issueWarnings({firstID,firstID,secondID,firstID})  
  In FunctionHandleConstraint>FunctionHandleConstraint.invoke at 39  
  In WarningQualificationConstraint>WarningQualificationConstraint.invoke  
  In IssuesWarnings>IssuesWarnings.invoke at 409  
  In IssuesWarnings>IssuesWarnings.issuesExpectedWarnings at 456  
  In IssuesWarnings>IssuesWarnings.satisfiedBy at 242  
  In QualificationDelegate>QualificationDelegate.qualifyThat at 58  
  In Verifiable>Verifiable.verifyThat at 228
```

Warning: Message

```
> In @(id)warning(id,'Message')  
  In @(idCell)cellfun(@(id)warning(id,'Message'),idCell)  
  In @()issueWarnings({firstID,firstID,secondID,firstID})  
  In FunctionHandleConstraint>FunctionHandleConstraint.invoke at 39  
  In WarningQualificationConstraint>WarningQualificationConstraint.invoke  
  In IssuesWarnings>IssuesWarnings.invoke at 409  
  In IssuesWarnings>IssuesWarnings.issuesExpectedWarnings at 456  
  In IssuesWarnings>IssuesWarnings.satisfiedBy at 242  
  In QualificationDelegate>QualificationDelegate.qualifyThat at 58  
  In Verifiable>Verifiable.verifyThat at 228
```

Warning: Message

```
> In @(id)warning(id,'Message')  
  In @(idCell)cellfun(@(id)warning(id,'Message'),idCell)  
  In @()issueWarnings({firstID,firstID,secondID,firstID})  
  In FunctionHandleConstraint>FunctionHandleConstraint.invoke at 39  
  In WarningQualificationConstraint>WarningQualificationConstraint.invoke  
  In IssuesWarnings>IssuesWarnings.invoke at 409
```

matlab.unittest.constraints.IssuesWarnings

```
In IssuesWarnings>IssuesWarnings.issuesExpectedWarnings at 456
In IssuesWarnings>IssuesWarnings.satisfiedBy at 242
In QualificationDelegate>QualificationDelegate.qualifyThat at 58
In Verifiable>Verifiable.verifyThat at 228
Warning: Message
> In @(id)warning(id,'Message')
   In @(idCell)cellfun(@(id)warning(id,'Message'),idCell)
   In @()issueWarnings({firstID,firstID,secondID,firstID})
   In FunctionHandleConstraint>FunctionHandleConstraint.invoke at 39
   In WarningQualificationConstraint>WarningQualificationConstraint.in
   In IssuesWarnings>IssuesWarnings.invoke at 409
   In IssuesWarnings>IssuesWarnings.issuesExpectedWarnings at 456
   In IssuesWarnings>IssuesWarnings.satisfiedBy at 242
   In QualificationDelegate>QualificationDelegate.qualifyThat at 58
   In Verifiable>Verifiable.verifyThat at 228
Interactive verification failed.
```

```
-----
Framework Diagnostic:
-----
```

```
IssuesWarnings failed.
```

```
--> The function handle did not issue a correct warning profile.
    The expected warning profile must match exactly.
```

```
--> The function handle did not issue the exact warning profile ex
```

```
Actual Warning Profile:
```

```
    first:id
    first:id
    second:id
    first:id
```

```
Expected Warning Profile:
```

```
    first:id
    second:id
    first:id
    first:id
```

```
Evaluated Function:
```

matlab.unittest.constraints.IssuesWarnings

```
@()issueWarnings({firstID,firstID,secondID,firstID})
```

Test whether the warning array is the same as the expected array when respecting set, order and count.

```
testCase.verifyThat(actVal, IssuesWarnings(warnArr,...  
    'RespectingSet',true, 'RespectingOrder',true, 'RespectingCount',true));
```

```
Interactive verification passed.
```

In this example, a constraint that specifies a warning profile that respects set, order and count is not the same as one that specifies an exact warning profile.

See Also

[matlab.unittest.constraints.IssuesNoWarnings](#) |
[matlab.unittest.constraints.Throws](#) | [warning](#)

Concepts

- “Message Identifiers”

Superclasses	Constraint
Purpose	Constraint specifying true value
Construction	IsTrue provides a constraint specifying a true value. This constraint is satisfied only by a scalar logical with a value of true.
Copy Semantics	Value. To learn how value classes affect copy operations, see Copying Objects in the MATLAB documentation.
Tips	<ul style="list-style-type: none">• For faster test execution, use <code>verifyTrue</code>, <code>assertTrue</code>, <code>assumeTrue</code>, or <code>fatalAssertTrue</code> instead of <code>IsTrue</code>.• To display custom comparisons in the form of a function handle, use <code>ReturnsTrue</code> instead of <code>IsTrue</code>.

Examples **Test Actual Value Is True**

Create a test case for interactive testing.

```
import matlab.unittest.TestCase;
import matlab.unittest.constraints.IsTrue;
```

```
testCase = TestCase.forInteractiveUse;
```

Test that true satisfies the `IsTrue` constraint.

```
testCase.verifyThat(true, IsTrue);
```

```
Interactive verification passed.
```

Test that the `IsTrue` constraint is not satisfied by false.

```
testCase.verifyThat(false, IsTrue);
```

```
Interactive verification failed.
```

```
-----
```

matlab.unittest.constraints.IsTrue

```
Framework Diagnostic:
-----
.IsTrue failed.
--> The value must evaluate to "true".
```

```
Actual Value:
      0
```

The test fails because `false` returns `logical(0)`.

Test that the `IsTrue` constraint is not satisfied by the double 1.

```
testCase.verifyThat(1, IsTrue);
```

```
Interactive verification failed.
```

```
-----
Framework Diagnostic:
-----
.IsTrue failed.
--> The value must be logical. It is of type "double".
```

```
Actual Value:
      1
```

The `IsTrue` constraint is satisfied only by `logical(1)`.

Test that the `IsTrue` constraint is not satisfied by a logical array of ones.

```
testCase.verifyThat([true true true], IsTrue);
```

```
Interactive verification failed.
```

```
-----
Framework Diagnostic:
-----
.IsTrue failed.
--> The value must be scalar. It has a size of [1 3].
```

Actual Value:

```
1    1    1
```

The `IsTrue` constraint is satisfied only if the value is scalar and `logical(1)`.

See Also

[IsFalse](#) | [ReturnsTrue](#)

Concepts

matlab.unittest.constraints.LogicalComparator

Purpose Comparator for two logical values

Construction LogicalComparator creates a comparator for two logical values. The comparator is satisfied if the actual and expected values have the same sparsity and the logical values are equivalent.

Copy Semantics Value. To learn how value classes affect copy operations, see Copying Objects in the MATLAB documentation.

Examples **Compare Logical Values**

Create a test case for interactive testing.

```
import matlab.unittest.TestCase;
import matlab.unittest.constraints.LogicalComparator;
import matlab.unittest.constraints.IsEqualTo;
```

```
testCase = TestCase.forInteractiveUse;
```

Test that the value of true.

```
testCase.assertThat(true, IsEqualTo(true, ...
    'Using', LogicalComparator));
```

```
Interactive assertion passed.
```

Test an array of true values.

```
testCase.assertThat([true true true], IsEqualTo(true, ...
    'Using', LogicalComparator));
```

```
Interactive assertion failed.
```

```
-----
Framework Diagnostic:
-----
IsEqualTo failed.
--> LogicalComparator failed.
```



```
--> The logical values are not equal
```

```
Actual Logical Value:  
      1      1      1  
Expected Logical Value:  
      1  
Assertion failed.
```

The actual value must be a scalar logical to satisfy the constraint.

Compare the value of 1 to true.

```
testCase.verifyThat(1, IsEqualTo(true, 'Using', LogicalComparator));
```

```
Interactive verification failed.
```

```
-----  
Framework Diagnostic:  
-----  
IsEqualTo failed.  
--> LogicalComparator failed.  
    --> The logical values are not equal
```

```
Actual Logical Value:  
      1  
Expected Logical Value:  
      1
```

Compare the value of false to true.

```
testCase.assertThat(false, IsEqualTo(true, 'Using', LogicalComparator));
```

```
Interactive assertion failed.
```

```
-----  
Framework Diagnostic:  
-----  
IsEqualTo failed.
```

matlab.unittest.constraints.LogicalComparator

```
--> LogicalComparator failed.  
    --> The logical values are not equal  
  
Actual Logical Value:  
    0  
Expected Logical Value:  
    1  
Assertion failed.
```

See Also [matlab.unittest.constraints.IsEqualTo](#)

Concepts

Superclasses	BooleanConstraint
Purpose	Constraint specifying string matches regular expression
Construction	<p><code>Matches(expr)</code> creates a constraint that specifies that a string matches a regular expression. The constraint is satisfied only if the actual value matches the given regular expression, <code>expr</code>.</p> <p><code>Matches(expr, 'IgnoringCase', caseInsensitive)</code> creates a constraint indicating whether to ignore case difference.</p>
	Input Arguments
	expr Regular expression that the actual value must match to satisfy the constraint, specified as a string. <code>expr</code> can include newline characters.
	caseInsensitive Indicator if the constraint is insensitive to case, specified as <code>false</code> or <code>true</code> (logical 0 or 1) Default: <code>false</code>
Properties	Expression Regular expression that the actual value must match, specified in the input argument, <code>expr</code> .
	IgnoreCase Indicator if the constraint is insensitive to case, specified in the input argument, <code>ignoreCase</code> . This property applies at all levels of recursion, such as nested structures.
Copy Semantics	Value. To learn how value classes affect copy operations, see Copying Objects in the MATLAB documentation.

Examples

Test That Actual Value Matches Regular Expression

Create a test case for interactive testing.

```
import matlab.unittest.TestCase
import matlab.unittest.constraints.Matches;
```

```
testCase = TestCase.forInteractiveUse;
```

Test that the actual value string, 'Epsilon Eridani', matches 'eps'.

```
testCase.verifyThat('Epsilon Eridani', Matches('^eps'));
```

```
Interactive verification failed.
```

```
-----
Framework Diagnostic:
-----
```

```
Matches failed.
```

```
--> The string did not match the regular expression.
```

```
Actual String:
```

```
    Epsilon Eridani
```

```
Regular Expression:
```

```
    ^eps
```

To satisfy the constraint, configure it to be case insensitive.

```
testCase.verifyThat('Epsilon Eridani', Matches('^eps', ...
    'IgnoringCase', true));
```

```
Interactive verification passed.
```

Define the regular expression that the actual value must match.

```
expr = 'Some[Ss]?tring';
```

The [Ss]? contained in the regular expression indicates that either 'S' or 's' matches at that location 0 or 1 times.

Test that the actual values, 'SomeString' and 'Somestring', satisfy the constraint.

```
testCase.verifyThat('SomeString', Matches(expr));
testCase.verifyThat('Somestring', Matches(expr));
```

```
Interactive verification passed.
Interactive verification passed.
```

Test that the actual value 'Somestring' satisfies the constraint.

```
testCase.verifyThat('Somestring', Matches(expr));
```

```
Interactive verification passed.
```

Test that the actual value 'somestring' satisfies the constraint.

```
testCase.verifyThat('somestring', Matches(expr));
```

```
Interactive verification failed.
```

```
-----
Framework Diagnostic:
-----
Matches failed.
--> The string did not match the regular expression.

Actual String:
    somestring
Regular Expression:
    Some[Ss]?tring
```

See Also

[ContainsSubstring](#) | [IsSubstringOf](#) | [EndsWithSubstring](#) | [StartsWithSubstring](#) | [regexp](#)

Concepts

- “Regular Expressions”

matlab.unittest.constraints.NumericComparator

Purpose	Comparator for numeric data types
Construction	<p><code>NumericComparator</code> creates a comparator for numeric data types. The comparator is satisfied if inputs are of the same class with equivalent size, complexity, and sparsity and the built-in <code>isequaln</code> function returns true.</p> <p><code>NumericComparator('Within', tolObj)</code> creates a comparator using a specified tolerance. In this case, <code>NumericComparator</code> first checks for equivalent class, size, and sparsity of the actual and expected values. If these checks fail, the comparator is not satisfied. If these checks pass and the <code>isequaln</code> or complexity check fails, <code>NumericComparator</code> delegates comparison to the supplied tolerance, <code>tolObj</code>.</p>
Input Arguments	<p>tolObj</p> <p>matlab.unittest.constraints.Tolerance instance</p>
Properties	<p>Tolerance</p> <p>Specific tolerance used in construction of the comparator, specified as a <code>Tolerance</code> object in the <code>tolObj</code> input argument.</p>
Copy Semantics	Value. To learn how value classes affect copy operations, see Copying Objects in the MATLAB documentation.
Examples	<p>Compare Numeric Values</p> <p>Create a test case for interactive testing.</p> <pre>import matlab.unittest.TestCase; import matlab.unittest.constraints.NumericComparator; import matlab.unittest.constraints.IsEqualTo; testCase = TestCase.forInteractiveUse;</pre> <p>Test 1.618 is equal to 1.618 using a numeric comparator.</p>

```
testCase.verifyThat(1.618, IsEqualTo(1.618,...  
    'Using', NumericComparator));
```

Interactive verification passed.

Verify that $(1+\sqrt{5})/2$ is equal to 1.618.

```
testCase.verifyThat((1+sqrt(5))/2, IsEqualTo(1.618, ...  
    'Using', NumericComparator));
```

Interactive verification failed.

```
-----  
Framework Diagnostic:  
-----  
IsEqualTo failed.  
--> NumericComparator failed.  
    --> The values are not equal using "isequaln".
```

```
Actual Value:  
    1.618033988749895  
Expected Value:  
    1.618000000000000
```

Retest using a relative tolerance of 0.25%.

```
import matlab.unittest.constraints.RelativeTolerance
```

```
testCase.verifyThat((1+sqrt(5))/2, IsEqualTo(1.618, ...  
    'Using', NumericComparator('Within', RelativeTolerance(0.0025))));
```

Interactive verification passed.

See Also

matlab.unittest.constraints.IsEqualTo |
matlab.unittest.constraints.Tolerance | isequaln

Concepts

matlab.unittest.constraints.ObjectComparator

Purpose	Comparator for MATLAB or Java objects
Construction	<p>ObjectComparator creates a comparator for MATLAB or Java objects. The comparator is satisfied if the built-in <code>isequal</code> function returns <code>true</code>.</p> <p>ObjectComparator('Within',tolObj) creates a comparator using a specified tolerance. In this case, ObjectComparator first checks that a call to <code>isequal</code> returns <code>true</code>. If the check fails, the ObjectComparator then checks for equivalent class, size, and sparsity of the actual and expected values. If these checks pass, ObjectComparator delegates comparison to the supplied tolerance, <code>tolObj</code>. This value of this tolerance must be of the same class as the actual and expected values.</p>
Input Arguments	<p>tolObj</p> <p>Tolerance instance</p>
Properties	<p>Tolerance</p> <p>Specific tolerance used in construction of the comparator, specified as a <code>matlab.unittest.constraints.Tolerance</code> object in the <code>tolObj</code> input argument.</p>
Copy Semantics	Value. To learn how value classes affect copy operations, see Copying Objects in the MATLAB documentation.
Examples	<p>Compare MATLAB Objects</p> <p>In a file, <code>MyInt.m</code>, in your working folder, create a subclass of <code>int8</code>.</p> <pre>classdef MyInt < int8 methods function i = MyInt(value) i@int8(value); end end end</pre>

matlab.unittest.constraints.ObjectComparator

At the command prompt, create a test case for interactive testing.

```
import matlab.unittest.TestCase;
import matlab.unittest.constraints.ObjectComparator;
import matlab.unittest.constraints.IsEqualTo;

testCase = TestCase.forInteractiveUse;
```

Use an `ObjectComparator` to test that two instances of `MyInt` are equal to each other.

```
testCase.verifyThat(MyInt(10), ...
    IsEqualTo(MyInt(10), 'Using', ObjectComparator));
```

```
Interactive verification passed.
```

Test that the equality of two instances of `MyInt` constructed with different input values.

```
testCase.verifyThat(MyInt(11), ...
    IsEqualTo(MyInt(10), 'Using', ObjectComparator));
```

```
Interactive verification failed.
```

```
-----
Framework Diagnostic:
-----
IsEqualTo failed.
--> ObjectComparator failed.
    --> The objects are not equal using "isequal".
```

```
Actual Object:
    MyInt:

        int8 data:
            11
Expected Object:
    MyInt:
```

matlab.unittest.constraints.ObjectComparator

```
int8 data:  
10
```

One instance of `MyInt` has a value of 11, and the other has a value of 10.

Repeat the test and specify values must be equal within an absolute tolerance of 1.

```
import matlab.unittest.constraints.AbsoluteTolerance;  
  
testCase.verifyThat(MyInt(11), IsEqualTo(MyInt(10), ...  
    'Using', ObjectComparator('Within', AbsoluteTolerance(MyInt(1))))));
```

```
Interactive verification passed.
```

See Also

[matlab.unittest.constraints.IsEqualTo](#) |
[matlab.unittest.constraints.Tolerance](#) | [isequal](#)

Concepts

matlab.unittest.constraints.PublicPropertyComparator

Purpose	Comparator for public properties of MATLAB objects
Description	<p>The <code>PublicPropertyComparator</code> compares public properties of MATLAB objects.</p> <p>The <code>PublicPropertyComparator</code> supports MATLAB objects or arrays of objects and recursively compares data structures contained in the public properties. The <code>PublicPropertyComparator</code> is different from the <code>isequal</code> function because it only examines the public properties of the objects.</p>
Construction	<p><code>PublicPropertyComparator</code> creates a comparator for public properties of MATLAB objects. This comparator only supports objects with no public properties.</p> <p><code>PublicPropertyComparator(compObj)</code> indicates a comparator, <code>compObj</code>, that defines the comparator used to compare public properties. This comparator only supports in recursion the data types supported by <code>compObj</code>.</p> <p><code>PublicPropertyComparator(___, Name, Value)</code> provides a comparator with additional options specified by one or more <code>Name, Value</code> pair arguments. You can specify several name-value pair arguments in any order as <code>Name1, Value1, ..., NameN, ValueN</code>. You can use this syntax with any of the input arguments of the previous syntaxes.</p> <p><code>PublicPropertyComparator.supportingAllValues</code> creates a comparator for public properties of MATLAB objects that supports any value in recursion. <code>supportingAllValues</code> is a <code>Static</code> method of the <code>PublicPropertyComparator</code> class.</p> <p>You typically pass this comparator to another constraint, such as <code>IsEqualTo</code>. You can use the <code>Name, Value</code> pairs of the <code>IsEqualTo</code> constraint in combination with a comparator constructed with the <code>PublicPropertyComparator.supportingAllValues</code> syntax.</p>

Input Arguments

compObj

Comparator object

Name-Value Pair Arguments

Specify optional comma-separated pairs of **Name**, **Value** arguments. **Name** is the argument name and **Value** is the corresponding value. **Name** must appear inside single quotes (' '). You can specify several name and value pair arguments in any order as **Name1**, **Value1**, ..., **NameN**, **ValueN**.

'IgnoringCase'

Indicator if the comparator is insensitive to case, specified as **false** or **true** (logical 0 or 1). When it is **false**, the comparator is sensitive to case. The comparator only uses this name-value pair if the contents being compared consists of strings.

Default: **false**

'IgnoringWhitespace'

Indicator if the comparator is insensitive to whitespace, specified as **false** or **true** (logical 0 or 1). When it is **false**, the comparator is sensitive to whitespace. Whitespace characters are space, form feed, new line, carriage return, horizontal tab, and vertical tab. The comparator only uses this name-value pair if the contents being compared consists of strings.

Default: **false**

'Recursively'

Indicator of whether comparator operates recursively, specified as **false** or **true** (logical 0 or 1). When this value is **false**, the comparator does not operate recursively on its data.

When the value is **true**, the data types the public property comparator supports are fully supported in recursion.

Default: false

'Within'

Tolerance to use for numerical comparison, specified as a `matlab.unittest.constraints.Tolerance` object. The comparator only uses this name-value pair if the contents being compared consists of numeric types.

Default: (empty)

Properties

IgnoreCase

Indicator if the comparator is insensitive to case, specified in the name-value pair argument, 'IgnoringCase'.

IgnoreWhitespace

Indicator if the comparator is insensitive to whitespace, specified in the name-value pair argument, 'IgnoringWhitespace'.

Recursive

Indicator of whether comparator operates recursively, specified in the name-value pair argument, 'Recursively'.

Tolerance

Specific tolerance used in construction of the comparator, specified as a `matlab.unittest.constraints.Tolerance` object in the name-value pair argument, 'Within'.

Copy Semantics

Value. To learn how value classes affect copy operations, see Copying Objects in the MATLAB documentation.

Examples

Instantiate PublicPropertyComparator Object

In a file, `Employee.m`, in your working folder, construct the following class.

```
classdef Employee
```

matlab.unittest.constraints.PublicPropertyComparator

```
        properties (SetAccess=immutable)
            Name;
        end
        properties (Access=private)
            Location;
        end
        methods
            function obj = Employee(name,location)
                obj.Name = name;
                obj.Location = location;
            end
        end
    end
end
```

At the command prompt, create two instances of the Employee class.

```
e1 = Employee('sam','Building A');
e2 = Employee('Sam','Building B');
```

Create a test case for interactive testing.

```
import matlab.unittest.TestCase;
import matlab.unittest.constraints.IsEqualTo;
import matlab.unittest.constraints.PublicPropertyComparator;
import matlab.unittest.constraints.StringComparator;
```

```
testCase = TestCase.forInteractiveUse;
```

Construct a comparator and verify that e1 and e2 are equal.

```
compObj = PublicPropertyComparator;
testCase.verifyThat(e1, IsEqualTo(e2, 'Using', compObj));
```

```
Error using matlab.unittest.constraints.ComparatorList/throwUnsupportedType
No comparator in list supports the char below:
    Sam
List contains the following comparators:
    <empty>
```

matlab.unittest.constraints.PublicPropertyComparator

```
Error in matlab.unittest.constraints.ComparatorList/getAndPrepareComparatorFor (line 10)
    list.throwUnsupportedType(expVal);

Error in matlab.unittest.constraints.ComparatorList/satisfiedBy (line 15)
    comp = list.getAndPrepareComparatorFor(expVal);

Error in matlab.unittest.internal.constraints.FieldComparator/findFirstDifferingField (line 10)
    bool = comp.satisfiedBy(actField, expField);

Error in matlab.unittest.internal.constraints.FieldComparator/fieldsHaveSameClass (line 10)
    bool = comparator.findFirstDifferingField(actVal, expVal);

Error in matlab.unittest.internal.constraints.FieldComparator/satisfiedBy (line 10)
    bool = haveSameClass(actVal, expVal) && ...

Error in matlab.unittest.constraints.IsEqualTo/satisfiedBy (line 165)
    bool = comp.supports(actual) && comp.satisfiedBy(actual, constraint);

Error in matlab.unittest.internal.qualifications.QualificationDelegate/satisfiedBy (line 10)
    result = constraint.satisfiedBy(actual);

Error in matlab.unittest.qualifications.Verifiable/verifyThat (line 20)
    qualifyThat(verifyable.VerificationDelegate, actual, constraint);
```

The test fails because, by default, the `PublicPropertyComparator` does not support strings.

Construct a comparator that supports strings. Specify that the comparison is not case-sensitive.

```
compObj = PublicPropertyComparator(StringComparator, 'IgnoringCase', true);
testCase.verifyThat(e1, IsEqualTo(e2, 'Using', compObj));
```

Interactive verification passed.

matlab.unittest.constraints.PublicPropertyComparator

Note that the test passes even though `e1.Location` and `e2.Location` are not the same. Since `Location` is a private property, the comparator does not compare its contents.

Instantiate PublicPropertyComparator Object to Support All Values

Create a test case for interactive testing.

```
import matlab.unittest.TestCase;
import matlab.unittest.constraints.IsEqualTo;
import matlab.unittest.constraints.PublicPropertyComparator;
```

```
testCase = TestCase.forInteractiveUse;
```

Test a passing case.

```
m1 = MException('Msg:ID','MsgText');
m2 = MException('Msg:ID','MsgText');
testCase.verifyThat(m1, IsEqualTo(m2, 'Using', ...
    PublicPropertyComparator.supportingAllValues));
```

Interactive verification passed.

Test a failing case.

```
m1 = MException('Msg:ID','MsgText');
m2 = MException('Msg:ID','msgtext');
testCase.verifyThat(m1, IsEqualTo(m2, 'Using', ...
    PublicPropertyComparator.supportingAllValues));
```

Interactive verification failed.

```
-----
Framework Diagnostic:
-----
IsEqualTo failed.
--> StringComparator failed.
    Path to failure: <Value>.message
```

matlab.unittest.constraints.PublicPropertyComparator

```
--> The strings are not equal

Actual String:
  MsgText
Expected String:
  msgtext

Actual MException:
  MException with properties:

    identifier: 'Msg:ID'
    message: 'MsgText'
    cause: {}
    stack: [0x1 struct]
Expected MException:
  MException with properties:

    identifier: 'Msg:ID'
    message: 'msgtext'
    cause: {}
    stack: [0x1 struct]
```

Test a case that passes when the comparator ignores differences in case.

```
m1 = MException('Msg:ID','MsgText');
m2 = MException('Msg:ID','msgtext');
testCase.verifyThat(m1, IsEqualTo(m2, 'IgnoringCase', true,...
    'Using', PublicPropertyComparator.supportingAllValues));
```

Interactive verification passed.

Instantiate PublicPropertyComparator Object with Tolerance

Create a test case for interactive testing.

```
import matlab.unittest.TestCase;
import matlab.unittest.constraints.IsEqualTo;
import matlab.unittest.constraints.RelativeTolerance;
```

matlab.unittest.constraints.PublicPropertyComparator

```
import matlab.unittest.constraints.PublicPropertyComparator;
```

```
testCase = TestCase.forInteractiveUse;
```

Define actual and expected timeseries objects. Perturb one of the actual data points by 1%.

```
expected = timeseries(1:10);  
actual = expected;  
actual.Data(7) = 1.01*actual.Data(7);
```

Test that the actual and expected values are equal within a relative tolerance of 2%.

```
testCase.verifyThat(actual, IsEqualTo(expected,...  
    'Within', RelativeTolerance(.02)));
```

```
Interactive verification failed.
```

```
-----  
Framework Diagnostic:  
-----
```

```
IsEqualTo failed.
```

```
--> ObjectComparator failed.
```

```
    --> The objects are not equal using "isequal".
```

```
    --> The tolerance does not support timeseries values so it was not used.
```

```
Actual Object:
```

```
    timeseries
```

```
Common Properties:
```

```
    Name: 'unnamed'
```

```
    Time: [10x1 double]
```

```
    TimeInfo: [1x1 tsdata.timemetadata]
```

```
    Data: [1x1x10 double]
```

```
    DataInfo: [1x1 tsdata.datametadata]
```

```
More properties, Methods
```

```
Expected Object:  
timeseries
```

```
Common Properties:
```

```
    Name: 'unnamed'  
    Time: [10x1 double]  
    TimeInfo: [1x1 tsdata.timemetadata]  
    Data: [1x1x10 double]  
    DataInfo: [1x1 tsdata.datametadata]
```

```
More properties, Methods
```

Use the `PublicPropertyComparator` in the construction of the constraint.

```
testCase.verifyThat(actual, IsEqualTo(expected,...  
    'Within', RelativeTolerance(.02),...  
    'Using', PublicPropertyComparator.supportingAllValues));
```

```
Interactive verification passed.
```

The test passes because the `PublicPropertyComparator` compares each public property individually instead of comparing the object all at once. In the former test, the `ObjectComparator` is used on the `timeseries` object, and therefore relies on the `isequal` method of the `timeseries` class. Due to the perturbation in the actual `timeseries`, `isequal` returns `false`. The comparator does not apply the tolerance because the double-valued tolerance cannot apply directly to the `timeseries` object. In the latter test, the comparator applies the tolerance to each public property that contains double-valued data.

See Also

```
matlab.unittest.constraints.IsEqualTo |  
matlab.unittest.constraints.ObjectComparator
```

Concepts

matlab.unittest.constraints.RelativeTolerance

Superclasses Tolerance

Purpose Relative numeric tolerance

Description This numeric Tolerance assesses the magnitude of the difference between actual and expected values, relative to the expected value. For the tolerance to be satisfied, `abs(expVal - actVal) <= relTol.*abs(expVal)` must be true.

Construction `RelativeTolerance(tolVals)` creates a relative tolerance object that assesses the magnitude of the difference between actual and expected values, relative to the expected value.

The data types of the inputs to the `RelativeTolerance` constructor determine the data types to which the tolerance is applied.

For example, `RelativeTolerance(10*eps)` constructs a `RelativeTolerance` for comparing double-precision numeric arrays while `RelativeTolerance(int8(2))` constructs a `RelativeTolerance` for comparing numeric arrays of type `int8`. If the actual and expected values being compared contain more than one numeric data type, the tolerance only applies to the data types specified by the values passed into the constructor.

You can specify different tolerance values for different data types by passing multiple tolerance values to the constructor. For example, `RelativeTolerance(10*eps, 10*eps('single'), int8(1))` constructs an `RelativeTolerance` that would apply the following absolute tolerances.

- `10*eps` applies a relative tolerance of `10*eps` for double-precision numeric arrays.
- `10*eps('single')` applies a relative tolerance of `10*eps` for single-precision numeric arrays.
- `int8(1)` applies a relative tolerance of 1 for numeric arrays of type `int8`.

More than one tolerance can be specified for a particular data type by combining tolerances with the & and | operators. In order to combine two tolerances, the sizes of the tolerance values for each data type must be compatible.

Input Arguments

tolVals

Numeric tolerances, specified as a cell array of numeric arrays. Each input argument contains the tolerance specification for a particular data type. Each numeric array can be a scalar or array with the same number of dimensions as the actual and expected values.

Properties

Values

Numeric tolerances, specified by the tolVals input argument.

Methods

and	Form logical element-wise conjunction of tolerances
or	Form logical element-wise disjunction of tolerances

Copy Semantics

Value. To learn how value classes affect copy operations, see Copying Objects in the MATLAB documentation.

Examples

Test with Relative Tolerance

Create a test case for interactive testing.

```
import matlab.unittest.TestCase;  
import matlab.unittest.constraints.IsEqualTo;  
import matlab.unittest.constraints.RelativeTolerance;
```

matlab.unittest.constraints.RelativeTolerance

```
testCase = TestCase.forInteractiveUse;
```

Assert that the difference between and actual value, 4.1, and an expected value, 4.5, is less than 10%.

```
testCase.assertThat(4.1, IsEqualTo(4.5, ...  
    'Within', RelativeTolerance(0.1)));
```

Interactive assertion passed.

Specify Relative Tolerance for Different Data Types

Create a test case for interactive testing.

```
import matlab.unittest.TestCase;  
import matlab.unittest.constraints.IsEqualTo;  
import matlab.unittest.constraints.RelativeTolerance;
```

```
testCase = TestCase.forInteractiveUse;
```

Create the following actual and expected cell arrays.

```
act = {'abc', 123, single(106)};  
exp = {'abc', 122, single(105)};
```

Test that the arrays satisfy the RelativeTolerance constraint within 2%.

```
testCase.verifyThat(act, IsEqualTo(exp, ...  
    'Within', RelativeTolerance(0.02)));
```

Interactive verification failed.

```
-----  
Framework Diagnostic:  
-----
```

```
IsEqualTo failed.
```

```
--> NumericComparator failed.
```

matlab.unittest.constraints.RelativeTolerance

```
Path to failure: <Value>{3}
--> The values are not equal using "isequaln".
--> The tolerance does not support single values so it was not used.
```

```
Actual Value:
    106
Expected Value:
    105
```

```
Actual cell:
    'abc'    [123]    [106]
Expected cell:
    'abc'    [122]    [105]
```

The test fails because the tolerance is only applied to the double data type.

Create a tolerance object that specifies different tolerances for different data types.

```
tolObj = RelativeTolerance(0.02, single(0.02));
```

A tolerance of 2% is applied to double and single valued data.

Verify that the expected and actual values satisfy the `RelativeTolerance` constraint.

```
testCase.verifyThat(act, IsEqualTo(exp, 'Within', tolObj));
```

```
Interactive verification passed.
```

Combine Relative and Absolute Tolerances

Create a test case for interactive testing.

```
import matlab.unittest.TestCase;
import matlab.unittest.constraints.IsEqualTo;
import matlab.unittest.constraints.AbsoluteTolerance;
import matlab.unittest.constraints.RelativeTolerance;
```

matlab.unittest.constraints.RelativeTolerance

```
testCase = TestCase.forInteractiveUse;
```

Define an actual value approximation for pi.

```
act = 3.14;
```

Construct a tolerance object to test that difference between the actual and expected values is within 0.001 and within 0.25%.

```
tolObj = AbsoluteTolerance(0.001) & RelativeTolerance(0.0025);
```

Verify that the actual value is within the tolerance of the expected value of pi.

```
testCase.verifyThat(act, IsEqualTo(pi, 'Within', tolObj));
```

```
Interactive verification failed.
```

```
-----  
Framework Diagnostic:  
-----
```

```
IsEqualTo failed.
```

```
--> NumericComparator failed.
```

```
    --> The values are not equal using "isequaln".
```

```
    --> AndTolerance failed.
```

```
        --> AbsoluteTolerance failed.
```

```
            --> The value was not within absolute tolerance.
```

```
                Tolerance Value:
```

```
                    1.0000000000000000e-03
```

```
            --> RelativeTolerance passed.
```

```
Actual Value:
```

```
    3.1400000000000000
```

```
Expected Value:
```

```
    3.141592653589793
```

The actual value does not satisfy the AbsoluteTolerance constraint.

Construct a constraint that is satisfied if the values are within 0.001 or 0.25%, and retest the actual value.

```
tolObj = AbsoluteTolerance(0.001) | RelativeTolerance(0.0025);  
testCase.verifyThat(act, IsEqualTo(pi, 'Within', tolObj));
```

Interactive verification passed.

Combine Absolute and Relative Tolerances to Test Small and Large Values

Typically when testing equality of values, an absolute (floor) tolerance dominates when the values are near zero, and a relative tolerance dominates for larger values.

Create a test case for interactive testing.

```
import matlab.unittest.TestCase;  
import matlab.unittest.constraints.IsEqualTo;  
import matlab.unittest.constraints.AbsoluteTolerance;  
import matlab.unittest.constraints.RelativeTolerance;
```

```
testCase = TestCase.forInteractiveUse;
```

Define two structures containing electromagnetic properties of a vacuum. One structure, `approxVacuumProps`, contains approximate values for the permeability and speed of light in a vacuum.

```
approxVacuumProps.Permeability = 1.2566e-06; % Approximate  
approxVacuumProps.Permittivity = 8.854187817*10^-12;  
approxVacuumProps.LightSpeed = 2.9979e+08; % Approximate
```

```
baselineVacuumProps.Permeability = 4*pi*10^-7;  
baselineVacuumProps.Permittivity = 8.854187817*10^-12;  
baselineVacuumProps.LightSpeed = 1/sqrt(...  
    baselineVacuumProps.Permeability*baselineVacuumProps.Permittivity);
```

matlab.unittest.constraints.RelativeTolerance

Test that the relative difference between the approximate and baseline values is within $\text{eps} \times 1e11$.

```
testCase.verifyThat(approxVacuumProps, IsEqualTo(baselineVacuumProps, ...
    'Within', RelativeTolerance(eps*1e11)));
```

Interactive verification failed.

Framework Diagnostic:

IsEqualTo failed.

--> NumericComparator failed.

Path to failure: <Value>.Permeability

--> The values are not equal using "isequaln".

--> RelativeTolerance failed.

--> The value was not within relative tolerance.

Tolerance Value:

2.220446049250313e-05

Actual Value:

1.2566000000000000e-06

Expected Value:

1.256637061435917e-06

Actual struct:

Permeability: 1.2566000000000000e-06

Permittivity: 8.854187816999999e-12

LightSpeed: 299790000

Expected struct:

Permeability: 1.256637061435917e-06

Permittivity: 8.854187816999999e-12

LightSpeed: 2.997924580105029e+08

The test fails because the relative difference in the permeabilities is not within the tolerance. The difference between the two values is small,

but the numbers are close to zero, so the difference relative to their size isn't small enough to satisfy the tolerance.

Construct a tolerance object to test that the absolute difference between the approximate and baseline values is within $1e-4$.

```
testCase.verifyThat(approxVacuumProps, IsEqualTo(baselineVacuumProps, 'Within', AbsoluteTolerance(1e-4)));
```

Interactive verification failed.

```
-----  
Framework Diagnostic:  
-----  
IsEqualTo failed.  
--> NumericComparator failed.  
    Path to failure: <Value>.LightSpeed  
    --> The values are not equal using "isequaln".  
    --> AbsoluteTolerance failed.  
        --> The value was not within absolute tolerance.
```

```
    Tolerance Value:  
                1.0000000000000000e-04
```

```
    Actual Value:  
                299790000  
    Expected Value:  
                2.997924580105029e+08
```

```
Actual struct:  
    Permeability: 1.2566000000000000e-06  
    Permittivity: 8.854187816999999e-12  
    LightSpeed: 299790000  
Expected struct:  
    Permeability: 1.256637061435917e-06  
    Permittivity: 8.854187816999999e-12  
    LightSpeed: 2.997924580105029e+08
```

matlab.unittest.constraints.RelativeTolerance

The test fails because the absolute difference in the speed of light is not within the tolerance. The difference between the two values is small relative to their size, but too large to satisfy the tolerance.

Construct a logical disjunction of tolerance objects to test that the absolute difference between the approximate and baseline values is within $1e-4$ or the relative difference is within $\text{eps} \cdot 1e11$. This tolerance is used so permeability values, which are close to zero, satisfy the absolute (floor) tolerance, and speed of light values, which are large, satisfy the relative tolerance.

```
testCase.verifyThat(approxVacuumProps, IsEqualTo(baselineVacuumProps, ...  
    'Within', RelativeTolerance(eps*1e11)| AbsoluteTolerance(1e-4)));
```

```
Interactive verification passed.
```

See Also

[matlab.unittest.constraints.AbsoluteTolerance](#) |
[matlab.unittest.constraints.IsEqualTo](#)

Concepts

matlab.unittest.constraints.RelativeTolerance.and

Purpose Form logical element-wise conjunction of tolerances

Syntax `outTo1Obj = and(to1Obj1, to1Obj2)`

Description `outTo1Obj = and(to1Obj1, to1Obj2)` forms the logical element-wise conjunction of tolerances and returns a single tolerance, `outTo1Obj`. This is a means to specify that every element of the actual value should be equal to the expected value to within the tolerance specified by both `to1Obj1` and `to1Obj2`. A qualification failure occurs when either `to1Obj1` or `to1Obj2` is not satisfied for one or more elements of the comparison values.

Typically, the `and` method is not called directly, but the `and` operator, `&`, is used to denote the conjunction of any two tolerance objects.

Input Arguments

to1Obj
Tolerance instance

Examples Form Logical and of Tolerances

```
import matlab.unittest.TestCase;
import matlab.unittest.constraints.IsEqualTo;
import matlab.unittest.constraints.AbsoluteTolerance;
import matlab.unittest.constraints.RelativeTolerance;

% Create a TestCase for interactive use
testCase = TestCase.forInteractiveUse;

% Passing qualifications
testCase.verifyThat(101, IsEqualTo(100, 'Within', ...
    AbsoluteTolerance(2) & RelativeTolerance(0.02)));
testCase.verifyThat([101, 105], IsEqualTo([100, 100], 'Within', ...
    AbsoluteTolerance([2, 10]) & RelativeTolerance([0.02, 0.1])));

% Failing qualifications
testCase.verifyThat(101, IsEqualTo(100, 'Within', ...
```

matlab.unittest.constraints.RelativeTolerance.and

```
AbsoluteTolerance(2) & RelativeTolerance(0.02));  
testCase.verifyThat([101, 105], IsEqualTo([100, 100], 'Within', ...  
    AbsoluteTolerance(2) & RelativeTolerance(0.02));
```

See Also or

Purpose Form logical element-wise disjunction of tolerances

Syntax `outTo1Obj = or(tolObj1,tolObj2)`

Description `outTo1Obj = or(tolObj1,tolObj2)` forms the logical element-wise disjunction of tolerances and returns a single tolerance, `outTo1Obj`. This is a means to specify that every element of the actual value should be equal to the expected value to within the tolerance specified by either `tolObj1` or `tolObj2`. A qualification failure occurs when both `tolObj1` and `tolObj2` are not satisfied for one or more elements of the comparison values.

Forming the logical disjunction of tolerances is particularly useful when relative tolerance is used in general, but absolute tolerance is used when values are small.

Typically, the `or` method is not called directly, but the `or` operator, `|`, is used to denote the disjunction of any two tolerance objects.

Input Arguments

tolObj
Tolerance instance

Examples

Form Logical or of Tolerances

```
import matlab.unittest.TestCase;
import matlab.unittest.constraints.IsEqualTo;
import matlab.unittest.constraints.AbsoluteTolerance;
import matlab.unittest.constraints.RelativeTolerance;
```

```
% Create a TestCase for interactive use
testCase = TestCase.forInteractiveUse;
```

```
% Simple passing qualification
testCase.verifyThat(105, IsEqualTo(100, 'Within', ...
    AbsoluteTolerance(3) | RelativeTolerance(0.1)));
```

```
% The following qualification passes because the or
```

```
% operation is performed element-wise between the
% actual and expected values being compared:
testCase.verifyThat([8, 104], IsEqualTo([10, 100], 'Within', ...
    AbsoluteTolerance(3) | RelativeTolerance(0.05)));
% Note that the following would fail:
testCase.verifyThat([8, 104], ...
    IsEqualTo([10, 100], 'Within', AbsoluteTolerance(3)) | ...
    IsEqualTo([10, 100], 'Within', RelativeTolerance(0.05)));

% Failing qualifications
testCase.verifyThat(101, IsEqualTo(100, 'Within', ...
    AbsoluteTolerance(0.5) | RelativeTolerance(0)));
testCase.verifyThat([101, 101], IsEqualTo([100, 100], 'Within', ...
    AbsoluteTolerance([2, 0.5]) | RelativeTolerance([0.02, 0.001])));
```

See Also and

Superclasses	BooleanConstraint
Purpose	Constraint specifying function handle that returns true
Construction	<p>ReturnsTrue provides a constraint specifying that a function handle that returns true. The constraint that is satisfied only by a function handle that returns a scalar logical with a value of true.</p> <p>When negated using the tilde operator, ~, this constraint not only passes when the function handle returns false, but also when the function handle returns any non-scalar value (such as [true true]) or any non-logical (such as integer valued1).</p>
Copy Semantics	Handle. To learn how handle classes affect copy operations, see Copying Objects in the MATLAB documentation.
Tips	<ul style="list-style-type: none">• To display custom comparisons in the form of a function handle, use ReturnsTrue instead of IsTrue.
Examples	<p>Test Actual Value Specified by Function Handle Returns True</p> <p>These comparisons are shown for example only. There are other constraints that might better handle the particular comparisons.</p> <p>Create a test case for interactive testing.</p> <pre>import matlab.unittest.TestCase; import matlab.unittest.constraints>ReturnsTrue; testCase = TestCase.forInteractiveUse;</pre> <p>Verify that the ReturnsTrue constraint is satisfied by the value returned by a handle to true.</p> <pre>testCase.verifyThat(@true, ReturnsTrue);</pre> <p>Interactive verification passed.</p>

matlab.unittest.constraints.ReturnsTrue

Verify that the ReturnsTrue constraint is not satisfied by a handle to false.

```
testCase.verifyThat(@false, ReturnsTrue);
```

Interactive verification failed.

```
-----  
Framework Diagnostic:  
-----
```

```
ReturnsTrue failed.  
--> The function handle should have evaluated to "true".  
--> Returned value:  
    0
```

```
Actual Function Handle:  
    @false
```

Verify that a call to `isequal` returns true.

```
testCase.verifyThat(@( ) isequal(1,1), ReturnsTrue);
```

Interactive verification passed.

Verify that a function that returns a double-valued 1 does not satisfy the ReturnsTrue constraint.

```
testCase.verifyThat(@( ) double(true), ReturnsTrue)
```

Interactive verification failed.

```
-----  
Framework Diagnostic:  
-----
```

```
ReturnsTrue failed.  
--> The function handle should have returned a logical value. It was of t  
--> Returned value:  
    1
```

```
Actual Function Handle:  
    @()double(true)
```

Verify that the negation of a string comparison of 'a' and 'b' returns true.

```
testCase.verifyThat(@() ~strcmp('a','b'), ReturnsTrue);
```

```
Interactive verification passed.
```

Test if a comparison of 'a' to the cell array {'a','a'} returns true.

```
testCase.verifyThat(@() strcmp('a',{'a','a'}), ReturnsTrue);
```

```
Interactive verification failed.
```

```
-----  
Framework Diagnostic:  
-----
```

```
ReturnsTrue failed.
```

```
--> The function handle should have returned a scalar. The return value
```

```
--> Returned value:
```

```
    1    1
```

```
Actual Function Handle:  
    @()strcmp('a',{'a','a'})
```

The constraint is not satisfied because the call to strcmp results a logical array, not a logical scalar.

See Also

IsTrue | Constraint

Concepts

matlab.unittest.constraints.StartsWithSubstring

Superclasses BooleanConstraint

Purpose Constraint specifying string starting with substring

Construction `StartsWithSubstring(prefix)` creates a constraint specifying a string starting with a substring. The constraint is satisfied only if the actual value starts with an expected string, `prefix`.

`StartsWithSubstring(prefix,Name,Value)` provides a constraint with additional options specified by one or more `Name,Value` pair arguments. `Name` must appear inside single quotes (' '). You can specify several name-value pair arguments in any order as `Name1,Value1,...,NameN,ValueN`.

Input Arguments

prefix

Text at the start of the actual value, specified as a string. `prefix` can include newline characters.

Name-Value Pair Arguments

Specify optional comma-separated pairs of `Name,Value` arguments. `Name` is the argument name and `Value` is the corresponding value. `Name` must appear inside single quotes (' '). You can specify several name and value pair arguments in any order as `Name1,Value1,...,NameN,ValueN`.

IgnoringCase

Indicator if the constraint is insensitive to case, specified as `false` or `true` (logical 0 or 1)

Default: `false`

IgnoringWhitespace

Indicator if the constraint is insensitive to whitespace, specified as `false` or `true` (logical 0 or 1)

Default: false

Properties

IgnoreCase

Indicator if the constraint is insensitive to case, specified in the name-value pair argument, 'IgnoringCase'. This property applies at all levels of recursion, such as nested structures.

IgnoreWhitespace

Indicator if the constraint is insensitive to whitespace, specified in the name-value pair argument, 'IgnoringWhitespace'. This property applies at all levels of recursion, such as nested structures.

Prefix

Text at the start of the actual value, specified in the input argument, `prefix`.

Copy Semantics

Value. To learn how value classes affect copy operations, see Copying Objects in the MATLAB documentation.

Examples

Test That Actual Value Starts with Specified Substring

Create a test case for interactive testing.

```
import matlab.unittest.TestCase
import matlab.unittest.constraints.StartsWithSubstring;
```

```
testCase = TestCase.forInteractiveUse;
```

Define the actual value string.

```
actVal = 'This Is One Long String';
```

Test that `actVal` starts with the substring 'This'.

```
testCase.verifyThat(actVal, StartsWithSubstring('This'));
```

matlab.unittest.constraints.StartsWithSubstring

Interactive verification passed.

Test that actVal starts with the substring 'this is'.

```
testCase.verifyThat(actVal, StartsWithSubstring('this is'));
```

Interactive verification failed.

Framework Diagnostic:

StartsWithSubstring failed.

--> The string has an incorrect prefix.

Actual String:

 This Is One Long String

Expected Prefix:

 this is

By default, the StartsWithSubstring constraint is case sensitive.

Repeat the test, this time ignoring case.

```
testCase.verifyThat(actVal, StartsWithSubstring('this is', ...  
    'IgnoringCase', true));
```

Interactive verification passed.

Test that actVal starts with the substring 'thisisone'. For the test to pass, configure the constraint to ignore whitespace and case.

```
testCase.verifyThat(actVal, StartsWithSubstring('thisisone', ...  
    'IgnoringCase', true, 'IgnoringWhitespace', true));
```

Interactive verification passed.

Assert that actVal does not start with the substring 'long'.

```
testCase.assertThat(actVal, ~StartsWithSubstring('Long'));
```

Interactive assertion passed.

See Also

[ContainsSubstring](#) | [IsSubstringOf](#) | [EndsWithSubstring](#) | [Matches](#)

Concepts

matlab.unittest.constraints.StringComparator

Purpose

Comparator for two strings

Construction

`StringComparator` creates a comparator for two strings. The comparator is satisfied if the two strings are equal.

`StringComparator(,Name,Value)` creates a comparator with additional options specified by one or more `Name,Value` pair arguments. `Name` must appear inside single quotes (`' '`). You can specify several name-value pair arguments in any order as `Name1,Value1,...,NameN,ValueN`.

Input Arguments

Name-Value Pair Arguments

Specify optional comma-separated pairs of `Name,Value` arguments. `Name` is the argument name and `Value` is the corresponding value. `Name` must appear inside single quotes (`' '`). You can specify several name and value pair arguments in any order as `Name1,Value1,...,NameN,ValueN`.

'IgnoringCase'

Indicator if the comparator is insensitive to case, specified as `false` or `true` (logical 0 or 1). When it is `false`, the comparator is sensitive to case.

Default: `false`

'IgnoringWhitespace'

Indicator if the comparator is insensitive to whitespace, specified as `false` or `true` (logical 0 or 1). When it is `false`, the comparator is sensitive to whitespace. Whitespace characters are space, form feed, new line, carriage return, horizontal tab, and vertical tab.

Default: `false`

Properties

IgnoreCase

Indicator if the comparator is insensitive to case, specified in the name-value pair argument, 'IgnoreCase'.

IgnoreWhitespace

Indicator if the comparator is insensitive to whitespace, specified in the name-value pair argument, 'IgnoreWhitespace'.

Copy Semantics

Value. To learn how value classes affect copy operations, see Copying Objects in the MATLAB documentation.

Examples

Compare Cell Arrays

Create a test case for interactive testing.

```
import matlab.unittest.TestCase;
import matlab.unittest.constraints.StringComparator;
import matlab.unittest.constraints.IsEqualTo;
```

```
testCase = TestCase.forInteractiveUse;
```

Verify that the actual and expected strings are equal using a string comparator.

```
expected = 'coffee';
actual = 'coffee';
testCase.verifyThat(actual, IsEqualTo(expected, ...
    'Using', StringComparator));
```

```
Interactive verification passed.
```

Change the actual string and repeat the comparison.

```
expected = 'coF Fee';
testCase.verifyThat(actual, IsEqualTo(expected, ...
    'Using', StringComparator));
```

```
Interactive verification failed.
```

matlab.unittest.constraints.StringComparator

```
-----  
Framework Diagnostic:  
-----  
IsEqualTo failed.  
--> StringComparator failed.  
    --> The strings are not equal
```

```
Actual String:  
    coffee  
Expected String:  
    coF Fee
```

For the test to pass, construct a comparator that ignores case and whitespace.

```
testCase.verifyThat(actual, IsEqualTo(expected, ...  
    'Using', StringComparator('IgnoringCase', true, ...  
    'IgnoringWhitespace', true)));
```

```
Interactive verification passed.
```

See Also

[matlab.unittest.constraints.IsEqualTo](#) | [strcmp](#)

Concepts

Purpose

Comparator for MATLAB structure arrays

Construction

`StructComparator` creates a comparator for MATLAB structure arrays.

`StructComparator(compObj)` indicates a comparator, `compObj`, that defines the comparator used to compare values contained in the structure. By default, a `StructComparator` only supports empty structure arrays.

`StructComparator(__,Name,Value)` provides a comparator with additional options specified by one or more `Name,Value` pair arguments. `Name` must appear inside single quotes (' '). You can specify several name-value pair arguments in any order as `Name1,Value1,...,NameN,ValueN`.

Input Arguments

`compObj`

Comparator object

A comparator is passed into the `StructComparator` to provide support for data types during recursion. By default, the `StructComparator` only supports empty structure arrays.

Name-Value Pair Arguments

Specify optional comma-separated pairs of `Name,Value` arguments. `Name` is the argument name and `Value` is the corresponding value. `Name` must appear inside single quotes (' '). You can specify several name and value pair arguments in any order as `Name1,Value1,...,NameN,ValueN`.

'IgnoringCase'

Indicator if the comparator is insensitive to case, specified as `false` or `true` (logical 0 or 1). When it is `false`, the comparator is sensitive to case. The comparator only uses this name-value pair if the contents being compared are strings.

Default: `false`

'IgnoringWhitespace'

Indicator if the comparator is insensitive to whitespace, specified as `false` or `true` (logical 0 or 1). When it is `false`, the comparator is sensitive to whitespace. Whitespace characters are space, form feed, new line, carriage return, horizontal tab, and vertical tab. The comparator only uses this name-value pair if the contents being compared are strings.

Default: `false`

'Recursively'

Indicator of whether comparator operates recursively, specified as `false` or `true` (logical 0 or 1). When this value is `false`, the comparator does not operate recursively on its data.

When the value is `true`, the data types the `StructComparator` supports are fully supported in recursion. For example:

```
comp1 = StructComparator(NumericComparator);  
comp2 = StructComparator(NumericComparator, 'Recursively', true);
```

Both `comp1` and `comp2` support structures that contain numeric values as their fields. However, only `comp2` supports a structures that recursively contain either structures or numeric values as their fields.

Default: `false`

'Within'

Tolerance to use for numerical comparison, specified as a `matlab.unittest.constraints.Tolerance` object. This name-value pair is applicable to contents that are a numeric type.

Default: (empty)

Properties

IgnoreCase

Indicator if the comparator is insensitive to case, specified in the name-value pair argument, 'IgnoreCase'.

IgnoreWhitespace

Indicator if the comparator is insensitive to whitespace, specified in the name-value pair argument, 'IgnoringWhitespace'.

Recursive

Indicator of whether comparator operates recursively, specified in the name-value pair argument, 'Recursively'.

Tolerance

Specific tolerance used in construction of the comparator, specified as a `matlab.unittest.constraints.Tolerance` object in the name-value pair argument, 'Within'.

Copy Semantics

Value. To learn how value classes affect copy operations, see [Copying Objects in the MATLAB documentation](#).

Examples

Compare Numeric Structures

Create a test case for interactive testing.

```
import matlab.unittest.TestCase;
import matlab.unittest.constraints.IsEqualTo;
import matlab.unittest.constraints.AbsoluteTolerance;
import matlab.unittest.constraints.StructComparator;
import matlab.unittest.constraints.NumericComparator;
```

```
testCase = TestCase.forInteractiveUse;
```

Create two equal structures.

```
s1 = struct('id',7,'score',7.3);
s2 = s1;
```

matlab.unittest.constraints.StructComparator

Test that the structures are equal. By default, the `StructComparator` only supports empty structures, so you need to configure the comparator with a `NumericComparator`.

```
testCase.verifyThat(s1, IsEqualTo(s2, 'Using', ...  
    StructComparator(NumericComparator)));
```

Interactive verification passed.

Change the score of `s2` and compare the structures again.

```
s2.score = 7.6;  
testCase.verifyThat(s1, IsEqualTo(s2, 'Using', ...  
    StructComparator(NumericComparator)));
```

Interactive verification failed.

```
-----  
Framework Diagnostic:  
-----  
IsEqualTo failed.  
--> NumericComparator failed.  
    Path to failure: <Value>.score  
    --> The values are not equal using "isequaln".  
  
    Actual Value:  
        7.300000000000000  
    Expected Value:  
        7.600000000000000  
  
Actual struct:  
    id: 7  
    score: 7.300000000000000  
Expected struct:  
    id: 7  
    score: 7.600000000000000
```

Specify an absolute tolerance for the comparison.

```
testCase.verifyThat(s1, IsEqualTo(s2, 'Using', ...  
    StructComparator(NumericComparator, 'Within', ...  
    AbsoluteTolerance(0.5))));
```

Interactive verification passed.

Compare Character Structures

Create a test case for interactive testing.

```
import matlab.unittest.TestCase;  
import matlab.unittest.constraints.IsEqualTo;  
import matlab.unittest.constraints.StructComparator;  
import matlab.unittest.constraints.StringComparator;
```

```
testCase = TestCase.forInteractiveUse;
```

Create two structures. One of the fields is a nested structure.

```
e1 = struct('name', struct('first','sam','last','smith'), ...  
    'location','Building A');  
e2 = e1;
```

Verify that the two structures are equal. Since the struct contains a nested struct, configure the constraint to operate recursively.

```
testCase.verifyThat(e1, IsEqualTo(e2, 'Using', ...  
    StructComparator(StringComparator, 'Recursively', true)));
```

Interactive verification passed.

Change the first name field of the e2 structure and repeat the comparison.

```
e2.name.first = ' SAM';  
testCase.verifyThat(e1, IsEqualTo(e2, 'Using', ...  
    StructComparator(StringComparator, 'Recursively', true)));
```

Interactive verification failed.

matlab.unittest.constraints.StructComparator

```
-----  
Framework Diagnostic:  
-----  
IsEqualTo failed.  
--> StringComparator failed.  
    Path to failure: <Value>.name.first  
    --> The strings are not equal
```

```
    Actual String:  
        sam  
    Expected String:  
        SAM
```

```
Actual struct:  
    name: [1x1 struct]  
    location: 'Building A'  
Expected struct:  
    name: [1x1 struct]  
    location: 'Building A'
```

Configure the comparator to ignore case and whitespace.

```
testCase.verifyThat(e1, IsEqualTo(e2, 'Using', ...  
    StructComparator(StringComparator, 'Recursively', true, ...  
    'IgnoringCase', true, 'IgnoringWhitespace', true)));
```

Interactive verification passed.

See Also

matlab.unittest.constraints.IsEqualTo |
matlab.unittest.constraints.Tolerance

Concepts

Superclasses	Constraint
Purpose	Constraint specifying function handle that throws MException
Description	<p>The Throws class creates a constraint that is satisfied only if the actual value is a function handle that throws a specific exception.</p> <p>If the function throws an MException and the constraint's ExpectedException property is an error identifier, a qualification failure occurs if the actual MException thrown has a different identifier. Alternately, if the ExpectedException property is a meta.class, the constraint is not satisfied if the actual MException thrown does not derive from the ExpectedException.</p>

Construction `outConstObj = Throws(excep)` provides a constraint, `outConstObj`, specifying a function handle that throws a particular MException, `excep`.

`outConstObj = Throws(excep,Name,Value)` provides a constraint with additional options specified by one or more `Name,Value` pair arguments. `Name` must appear inside single quotes (' '). You can specify several name-value pair arguments in any order as `Name1,Value1,...,NameN,ValueN`.

Input Arguments

excep

Error identifier or `meta.class` representing the specific type of expected exception. The Throws constructor throws an MException if `excep` is a `meta.class` but does not derive from MException.

Name-Value Pair Arguments

Specify optional comma-separated pairs of `Name,Value` arguments. `Name` is the argument name and `Value` is the corresponding value. `Name` must appear inside single quotes (' '). You can

matlab.unittest.constraints.Throws

specify several name and value pair arguments in any order as `Name1, Value1, ..., NameN, ValueN`.

CausedBy

Expected causes, specified as a cell array of strings and/or `meta.class` instances.

The testing results in a qualification failure if any causes specified in `CausedBy` are not found within the cause tree.

Default: `{}`

WhenNargoutIs

Number of outputs the constraint should request when invoking the function handle, specified as a non-negative, real, scalar integer.

Default: `0`

Properties

ExpectedException

Expected `MException` identifier or class. Set this read only property through the constructor via the `except` input argument.

Nargout

Number of output arguments the instance uses when executing functions. Set this property through the constructor via the name-value pair argument, `'WhenNargoutIs'`.

RequiredCauses

Expected causes for the function handle throwing an `MException`. Set this property through the constructor via the name-value pair argument, `'CausedBy'`.

Copy Semantics

Handle. To learn how handle classes affect copy operations, see Copying Objects in the MATLAB documentation.

Examples

Instantiate Throws Constraint

Create a test case for interactive testing.

```
import matlab.unittest.TestCase;
import matlab.unittest.constraints.Throws;
```

```
testCase = TestCase.forInteractiveUse;
```

Verify that a function throws a specified error id.

```
testCase.verifyThat(@() error('SOME:error:id', 'Error!'), ...
    Throws('SOME:error:id'));
```

```
Interactive verification passed.
```

Verify that a function throws a specified exception class.

```
testCase.verifyThat(@() error('SOME:error:id', 'Error!'), ...
    Throws(?MException));
```

```
Interactive verification passed.
```

Verify that a function, when called with a specified number of outputs, throws a specified error.

```
testCase.verifyThat(@() disp('hi'), Throws('MATLAB:maxlhs', ...
    'WhenNargoutIs', 1));
```

```
Interactive verification passed.
```

Check causes by identifier.

```
me = MException('TOP:error:id', 'TopLevelError!');
causeBy = MException('causedBy:someOtherError:id', 'CausedByError!');
me = me.addCause(causeBy);
testCase.verifyThat(@() me.throw, Throws('TOP:error:id', 'CausedBy', ...
    {'causedBy:someOtherError:id'}));
```

matlab.unittest.constraints.Throws

Interactive verification passed.

Check causes by class.

```
me = MException('TOP:error:id','TopLevelError!');
causeBy = MException('causedBy:someOtherError:id','CausedByError!');
me = me.addCause(causeBy);
testCase.verifyThat(@() me.throw, Throws('TOP:error:id','CausedBy', ...
    {?MException}));
```

Interactive verification passed.

Verify that the constraint is not satisfied if the actual value is not a function handle.

```
testCase.fatalAssertThat(5, Throws('some:id'));
```

Interactive fatal assertion failed.

```
-----
Framework Diagnostic:
-----
```

Throws failed.

--> The value must be an instance of the expected type.

```
Actual Class:
    double
Expected Type:
    function_handle
```

Actual Value:

5

Fatal assertion failed.

Verify that the constraint is not satisfied if the function does not throw an exception.

```
testCase.assumeThat(@rand, Throws(?MException));
```

Interactive assumption failed.

Framework Diagnostic:

Throws failed.

--> The function did not throw any exception.

Expected Exception Type:
MException

Evaluated Function:
@rand

Assumption failed.

Verify that the constraint is not satisfied if the function issues a non-specified error identifier.

```
testCase.verifyThat(@() error('SOME:id'), Throws('OTHER:id'));
```

Interactive verification failed.

Framework Diagnostic:

Throws failed.

--> The function threw an exception with the wrong identifier.

Actual Identifier:
MATLAB:error:missingMessageArgument
Expected Identifier:
OTHER:id

Evaluated Function:
@()error('SOME:id')

Verify that the constraint is not satisfied if the function throws an exception and the cause does not match the specified identifier.

matlab.unittest.constraints.Throws

```
testCase.verifyThat(@() error('TOP:error:id','TopLevelError!'), ...
    Throws('TOP:error:id','CausedBy',{'causedBy:someOtherError:id'}));
```

Interactive verification failed.

```
-----  
Framework Diagnostic:  
-----
```

Throws failed.

--> The following causes were not found in the exception tree:

--> Identifier:

causedBy:someOtherError:id

Evaluated Function:

```
@()error('TOP:error:id','TopLevelError!')
```

See Also

[MException](#) | [error](#) |
[matlab.unittest.constraints.IssuesWarnings](#)
| [matlab.unittest.constraints](#)

Concepts

- “Message Identifiers”

Purpose

Abstract interface class for tolerances

Description

Tolerances define a notion of fuzzy equality for a set of data types and can be plugged in to the `IsEqualTo` constraint through the `'Within'` name-value pair argument.

Classes that derive from the `Tolerance` interface class must provide a tolerance definition. Implement this via the `satisfiedBy` method. Classes that derive from the `Tolerance` class also must provide a diagnostic for two compared values. The testing framework uses the diagnostic when the compared values are outside of the allowable tolerance. Implement this via the `getDiagnosticFor` method. Finally, classes that derive from the `Tolerance` class must provide a means to determine which data types the tolerance supports. Define the supported data types by implementing the `supports` method.

Methods

<code>getDiagnosticFor</code>	Produce diagnostic for two values specified to be within tolerance
<code>satisfiedBy</code>	Determine whether two values are within tolerance
<code>supports</code>	Determine whether tolerance supports specified data type

Copy Semantics

Value. To learn how value classes affect copy operations, see [Copying Objects](#) in the MATLAB documentation.

Examples

Create Custom Tolerance Class

Determine if two DNA sequences have a Hamming distance within a specified tolerance. For two DNA sequences (strings) of the same length, the Hamming distance is the number of positions in which the nucleotides (letters) of one sequence differ from the other.

In a file, `DNA.m`, in your working folder, create a simple class for a DNA sequence.

matlab.unittest.constraints.Tolerance

```
classdef DNA
    properties(SetAccess=immutable)
        Sequence
    end

    methods
        function dna = DNA(sequence)
            validLetters = ...
                sequence == 'A' | ...
                sequence == 'C' | ...
                sequence == 'T' | ...
                sequence == 'G';

            if ~all(validLetters(:))
                error('Sequence contained a letter not found in DNA.');
            end
            dna.Sequence = sequence;
        end
    end
end
```

In a file in your working folder, create a tolerance class so that you can test that DNA sequences are within a specified Hamming distance. The constructor requires a `Value` property that defines the maximum Hamming distance.

```
classdef HammingDistance < matlab.unittest.constraints.Tolerance
    properties
        Value
    end

    methods
        function tolerance = HammingDistance(value)
            tolerance.Value = value;
        end
    end
end
```

Tolerance classes must implement a `supports` method. In a `methods` block with the `HammingDistance` class definition, include the following method so that the tolerance supports DNA objects.

```
methods
    function tf = supports(~, value)
        tf = isa(value, 'DNA');
    end
end
```

Tolerance classes must implement a `satisfiedBy` method. The testing framework uses this method to determine if two values are within the tolerance. In a `methods` block with the `HammingDistance` class definition, include the following method that returns true or false.

```
methods
    function tf = satisfiedBy(tolerance, actual, expected)
        if ~isSameSize(actual.Sequence, expected.Sequence)
            tf = false;
            return
        end
        tf = hammingDistance(actual.Sequence, expected.Sequence) <
    end
end
```

In the `HammingDistance.m` file, define the following helper functions outside of the `classdef` block. The `isSameSize` function returns true if two DNA sequences are the same size, and the `hammingDistance` function returns the Hamming distance between two sequences.

```
function tf = isSameSize(str1, str2)
tf = isequal(size(str1), size(str2));
end
```

```
function distance = hammingDistance(str1, str2)
distance = nnz(str1 ~= str2);
end
```

matlab.unittest.constraints.Tolerance

Tolerance classes must implement a `getDiagnosticFor` method. The function returns a `Diagnostic` object with information about the comparison. In a methods block with the `HammingDistance` class definition, include the following method that returns a `StringDiagnostic`.

```
methods
    function diag = getDiagnosticFor(tolerance, actual, expected)
        import matlab.unittest.diagnostics.StringDiagnostic;

        if ~isSameSize(actual.Sequence, expected.Sequence)
            str = 'The DNA sequences must be the same length.';
        else
            str = sprintf('%s%d.\n%s%d.', ...
                'The DNA sequences have a Hamming distance of ', ...
                hammingDistance(actual.Sequence, expected.Sequence),
                'The allowable distance is ', ...
                tolerance.Value);
        end
        diag = StringDiagnostic(str);
    end
end
```

HammingDistance Class Definition Summary

```
classdef HammingDistance < matlab.unittest.constraints.Tolerance
    properties
        Value
    end

    methods
        function tolerance = HammingDistance(value)
            tolerance.Value = value;
        end

        function tf = supports(~, value)
            tf = isa(value, 'DNA');
        end
    end
end
```

```
function tf = satisfiedBy(tolerance, actual, expected)
    if ~isSameSize(actual.Sequence, expected.Sequence)
        tf = false;
        return
    end
    tf = hammingDistance(actual.Sequence, expected.Sequence) <
end

function diag = getDiagnosticFor(tolerance, actual, expected)
    import matlab.unittest.diagnostics.StringDiagnostic;

    if ~isSameSize(actual.Sequence, expected.Sequence)
        str = 'The DNA sequences must be the same length.';
    else
        str = sprintf('%s%d.\n%s%d.', ...
            'The DNA sequences have a Hamming distance of ',
            hammingDistance(actual.Sequence, expected.Sequence),
            'The allowable distance is ', ...
            tolerance.Value);
    end
    diag = StringDiagnostic(str);
end
end

function tf = isSameSize(str1, str2)
    tf = isequal(size(str1), size(str2));
end

function distance = hammingDistance(str1, str2)
    distance = nnz(str1 ~= str2);
end
```

At the command prompt, create a TestCase for interactive testing.

```
import matlab.unittest.TestCase;
```

matlab.unittest.constraints.Tolerance

```
import matlab.unittest.constraints.IsEqualTo;
```

```
testCase = TestCase.forInteractiveUse;
```

Create two DNA objects.

```
sampleA = DNA('ACCTGAGTA');
```

```
sampleB = DNA('ACCACAGTA');
```

Verify that the DNA sequences are equal to each other.

```
testCase.verifyThat(sampleA, IsEqualTo(sampleB));
```

```
Interactive verification failed.
```

```
-----  
Framework Diagnostic:  
-----
```

```
IsEqualTo failed.
```

```
--> ObjectComparator failed.
```

```
    --> The objects are not equal using "isequal".
```

```
Actual Object:
```

```
    DNA with properties:
```

```
        Sequence: 'ACCTGAGTA'
```

```
Expected Object:
```

```
    DNA with properties:
```

```
        Sequence: 'ACCACAGTA'
```

Verify that the DNA sequences are equal to each other, within a Hamming distance of 1.

```
testCase.verifyThat(sampleA, IsEqualTo(sampleB,...  
    'Within', HammingDistance(1)));
```

```
Interactive verification failed.
```

```
-----  
Framework Diagnostic:  
-----  
IsEqualTo failed.  
--> ObjectComparator failed.  
    --> The objects are not equal using "isequal".  
    --> The DNA sequences have a Hamming distance of 2.  
        The allowable distance is 1.
```

```
Actual Object:  
    DNA with properties:  
        Sequence: 'ACCTGAGTA'  
Expected Object:  
    DNA with properties:  
        Sequence: 'ACCACAGTA'
```

The sequences are not equal to each other within a tolerance of 1. The testing framework displays additional diagnostics from the `getDiagnosticFor` method.

Verify that the DNA sequences are equal to each other, within a Hamming distance of 2.

```
testCase.verifyThat(sampleA, IsEqualTo(sampleB,...  
    'Within', HammingDistance(2)));
```

```
Interactive verification passed.
```

Concepts

matlab.unittest.constraints.Tolerance.getDiagnosticFor

Purpose Produce diagnostic for two values specified to be within tolerance

Syntax `diag = getDiagnosticFor(tolObj,actVal,expVal)`

Description `diag = getDiagnosticFor(tolObj,actVal,expVal)` produces a diagnostic, `diag`, for a value, `actVal`, evaluated against another value, `expVal`, within the tolerance defined by `tolObj`. When creating a custom tolerance, the class author must implement the `getDiagnosticFor` method so that it analyzes the two values, `actVal` and `expVal`, against the tolerance, `tolObj`, and instantiates and returns a `matlab.unittest.diagnostics.Diagnostic` object.

Typically, this diagnostic is used when the `getDiagnosticFor` method of `IsEqualTo` is invoked, and the result is incorporated into the diagnostic output of the `IsEqualTo` constraint.

Input Arguments

actVal

Value to determine if is within tolerance of `expVal`

tolObj

Tolerance instance

expVal

Expected value

See Also

`supports` | `satisfiedBy` | `Diagnostic` | `ConstraintDiagnostic`

matlab.unittest.constraints.Tolerance.satisfiedBy

Purpose Determine whether two values are within tolerance

Syntax `TF = satisfiedBy(tolObj,actVal,expVal)`

Description `TF = satisfiedBy(tolObj,actVal,expVal)` determines whether two values, `actVal` and `expVal`, are within the tolerance defined by `tolObj`. The `satisfiedBy` method is used to determine whether the tolerance is met. It returns `true` or `false` (logical 0 or 1). When creating a custom tolerance, a class author uses this method to contain the tolerance definition.

Input Arguments

actVal

Value to determine if is within tolerance of `expVal`

tolObj

Tolerance instance

expVal

Expected value

See Also `getDiagnosticFor` | `supports`

matlab.unittest.constraints.Tolerance.supports

Purpose	Determine whether tolerance supports specified data type
Syntax	<code>TF = supports(tolObj,typeVal)</code>
Description	<p><code>TF = supports(tolObj,typeVal)</code> determines whether the tolerance supports a specific data type. It returns <code>true</code> or <code>false</code> (logical 0 or 1).</p> <p>The <code>supports</code> method provides the ability for a tolerance author to specify support for data types. Generally, the method operates by examining the type of <code>typeVal</code> to determine whether it is supported.</p>
Input Arguments	<p>tolObj Tolerance instance</p> <p>typeVal Value used to determine tolerance support</p>
See Also	<code>getDiagnosticFor</code> <code>satisfiedBy</code>

Purpose Grayscale colormap for contrast enhancement

Syntax
`cmap = contrast(X)`
`cmap = contrast(X,m)`

Description The `contrast` function enhances the contrast of an image. It creates a new gray colormap, `cmap`, that has an approximately equal intensity distribution. All three elements in each row are identical.

`cmap = contrast(X)` returns a gray colormap that is the same length as the current colormap. If there are NaN or Inf elements in `X` the length of the colormap increases.

`cmap = contrast(X,m)` returns an `m`-by-3 gray colormap.

Examples **Display Image with Gray Colormap**

Load `clown` to get image `X` and its associated colormap, `map`. Display the image produced by `X` and `map`.

```
load clown
figure
image(X)
colormap(map)
```

contrast

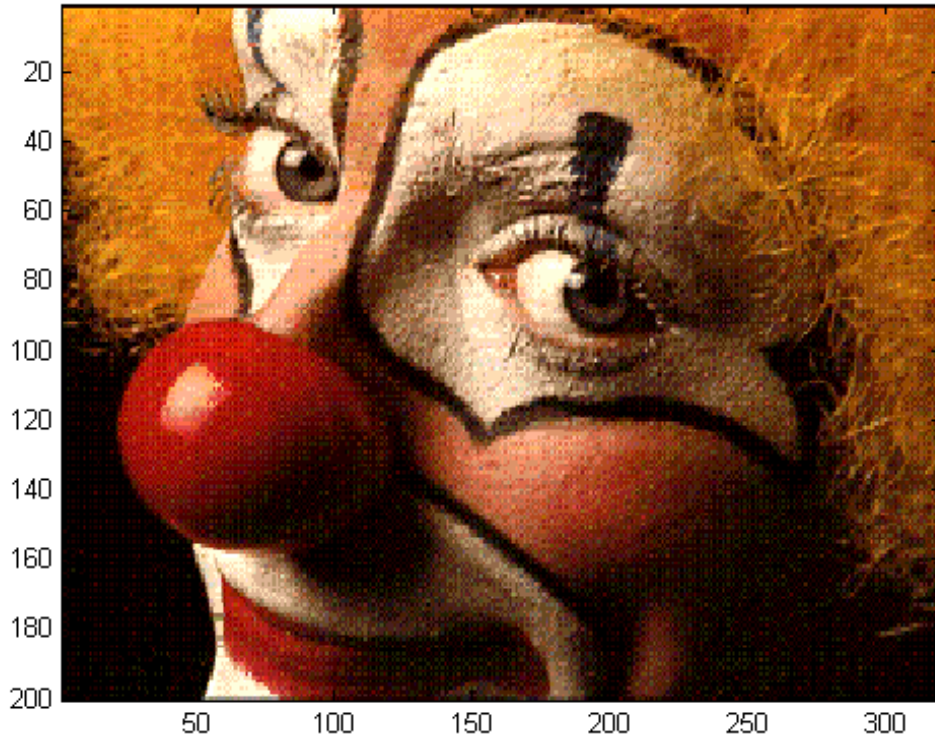

Use `contrast` to return a gray colormap that is the same length as the current colormap, `map`. Display the image with the new colormap, `cmap`.

```
cmap = contrast(X);  
colormap(cmap)
```

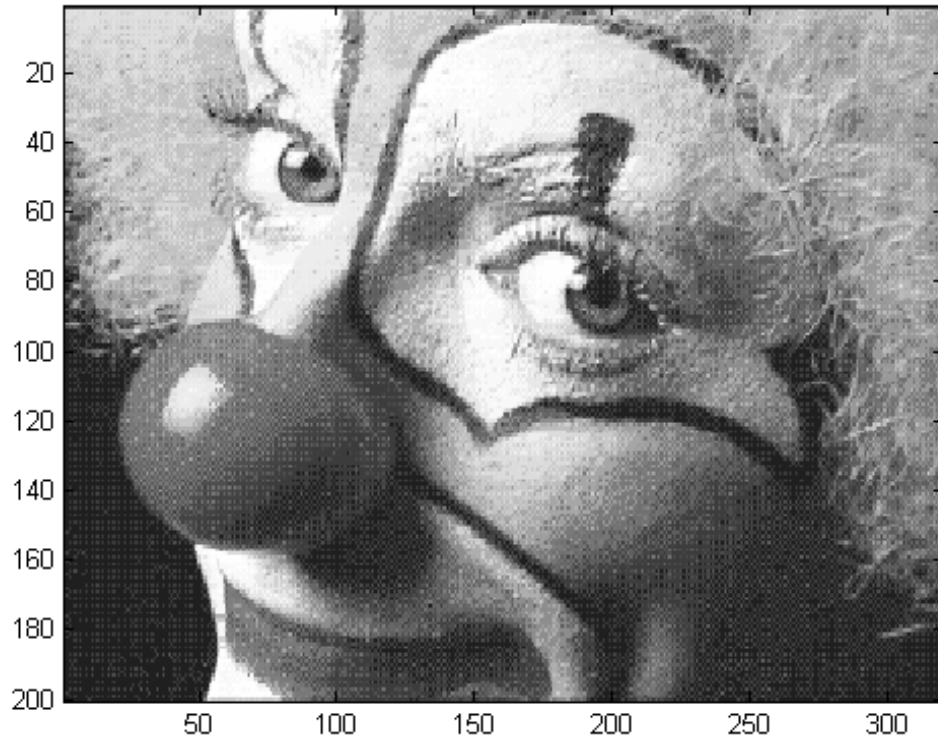

See Also `brighten` | `colormap` | `image`

conv

Purpose Convolution and polynomial multiplication

Syntax
`w = conv(u,v)`
`w = conv(..., 'shape')`

Description `w = conv(u,v)` convolves vectors `u` and `v`. Algebraically, convolution is the same operation as multiplying the polynomials whose coefficients are the elements of `u` and `v`.

`w = conv(..., 'shape')` returns a subsection of the convolution, as specified by the `shape` parameter:

<code>full</code>	Returns the full convolution (default).
<code>same</code>	Returns the central part of the convolution of the same size as <code>u</code> .
<code>valid</code>	Returns only those parts of the convolution that are computed without the zero-padded edges. Using this option, <code>length(w)</code> is <code>max(length(u)-max(0,length(v)-1),0)</code> .

Definitions Let $m = \text{length}(u)$ and $n = \text{length}(v)$. Then w is the vector of length $m+n-1$ whose k th element is

$$w(k) = \sum_j u(j)v(k-j+1)$$

The sum is over all the values of j which lead to legal subscripts for $u(j)$ and $v(k+1-j)$, specifically $j = \max(1, k+1-n) : \min(k, m)$. When $m = n$, this gives

$$\begin{aligned}w(1) &= u(1)*v(1) \\w(2) &= u(1)*v(2)+u(2)*v(1) \\w(3) &= u(1)*v(3)+u(2)*v(2)+u(3)*v(1) \\&\dots \\w(n) &= u(1)*v(n)+u(2)*v(n-1)+ \dots +u(n)*v(1) \\&\dots\end{aligned}$$

$$w(2*n-1) = u(n)*v(n)$$

See Also

`conv2` | `convn` | `deconv` | `filter` | `convmtx` | `xcorr`

conv2

Purpose 2-D convolution

Syntax
`C = conv2(A,B)`
`C = conv2(h1,h2,A)`
`C = conv2(...,shape)`

Description `C = conv2(A,B)` computes the two-dimensional convolution of matrices *A* and *B*. If one of these matrices describes a two-dimensional finite impulse response (FIR) filter, the other matrix is filtered in two dimensions. The size of *C* is determined as follows: if `[ma,na] = size(A)`, `[mb,nb] = size(B)`, and `[mc,nc] = size(C)`, then `mc = max([ma+mb-1,ma,mb])` and `nc = max([na+nb-1,na,nb])`.

`C = conv2(h1,h2,A)` first convolves *A* with the vector *h1* along the rows and then with the vector *h2* along the columns. The size of *C* is determined as follows: if `n1 = length(h1)` and `n2 = length(h2)`, then `mc = max([ma+n1-1,ma,n1])` and `nc = max([na+n2-1,na,n2])`.

`C = conv2(...,shape)` returns a subsection of the two-dimensional convolution, as specified by the *shape* parameter:

'full'	Returns the full two-dimensional convolution (default).
'same'	Returns the central part of the convolution of the same size as <i>A</i> .
'valid'	Returns only those parts of the convolution that are computed without the zero-padded edges. Using this option, <code>size(C) = max([ma-max(0,mb-1),na-max(0,nb-1)],0)</code> .

Note All numeric inputs to `conv2` must be of type `double` or `single`.

Algorithms `conv2` uses a straightforward formal implementation of the two-dimensional convolution equation in spatial form. If *a* and *b* are

functions of two discrete variables, n_1 and n_2 , then the formula for the two-dimensional convolution of a and b is

$$c(n_1, n_2) = \sum_{k_1=-\infty}^{\infty} \sum_{k_2=-\infty}^{\infty} a(k_1, k_2) b(n_1 - k_1, n_2 - k_2)$$

In practice however, `conv2` computes the convolution for finite intervals.

Note that matrix indices in MATLAB software always start at 1 rather than 0. Therefore, matrix elements $A(1, 1)$, $B(1, 1)$, and $C(1, 1)$ correspond to mathematical quantities $a(0, 0)$, $b(0, 0)$, and $c(0, 0)$.

Examples

Shape for Subsection of 2-D Convolution

For the 'same' case, `conv2` returns the central part of the convolution. If there are an odd number of rows or columns, the "center" leaves one more at the beginning than the end.

This example first computes the convolution of A using the default ('full') shape, then computes the convolution using the 'same' shape. Note that the array returned using 'same' corresponds to the red highlighted elements of the array returned using the default shape.

```
A = rand(3);
B = rand(4);
C = conv2(A,B) % C is 6-by-6
```

```
C =
    0.1838    0.2374    0.9727    1.2644    0.7890    0.3750
    0.6929    1.2019    1.5499    2.1733    1.3325    0.3096
    0.5627    1.5150    2.3576    3.1553    2.5373    1.0602
    0.9986    2.3811    3.4302    3.5128    2.4489    0.8462
    0.3089    1.1419    1.8229    2.1561    1.6364    0.6841
    0.3287    0.9347    1.6464    1.7928    1.2422    0.5423
```

```
Cs = conv2(A,B,'same') % Cs is the same size as A: 3-by-3
Cs =
    2.3576    3.1553    2.5373
```

```
3.4302  3.5128  2.4489
1.8229  2.1561  1.6364
```

Extract Edges from Raised Pedestal

In image processing, the Sobel edge finding operation is a two-dimensional convolution of an input array with the special matrix:

```
s = [1 2 1; 0 0 0; -1 -2 -1];
```

These commands extract the horizontal edges from a raised pedestal.

```
A = zeros(10);
A(3:7,3:7) = ones(5);
H = conv2(A,s);
figure, mesh(H)
```

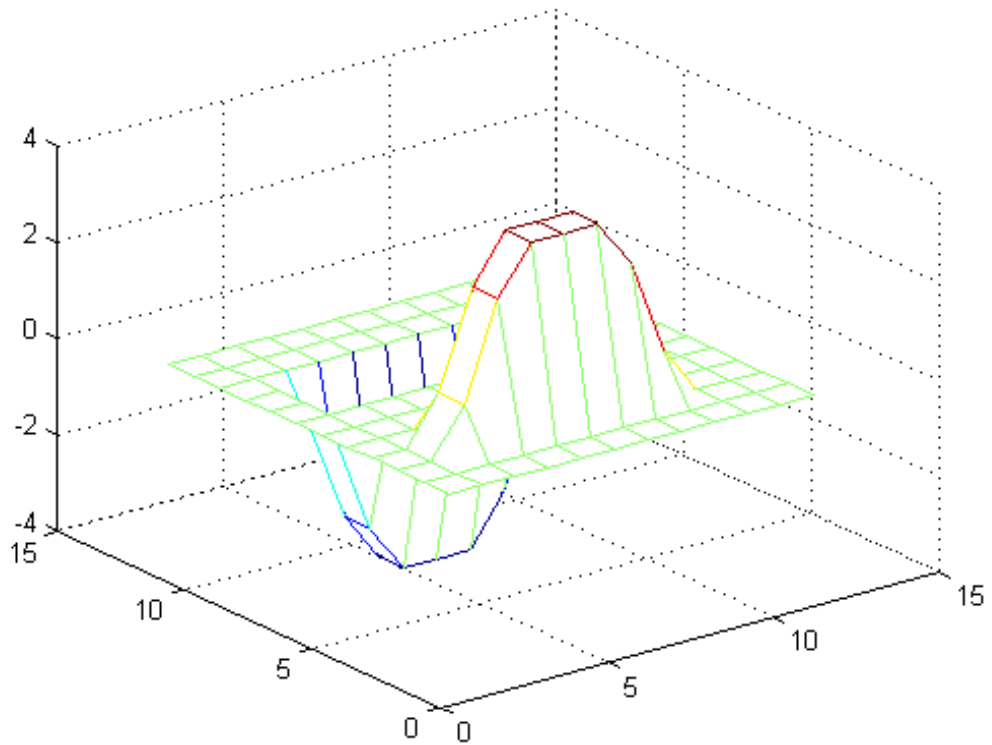
Transposing the filter s extracts the vertical edges of A .

```
V = conv2(A,s');  
figure, mesh(V)
```

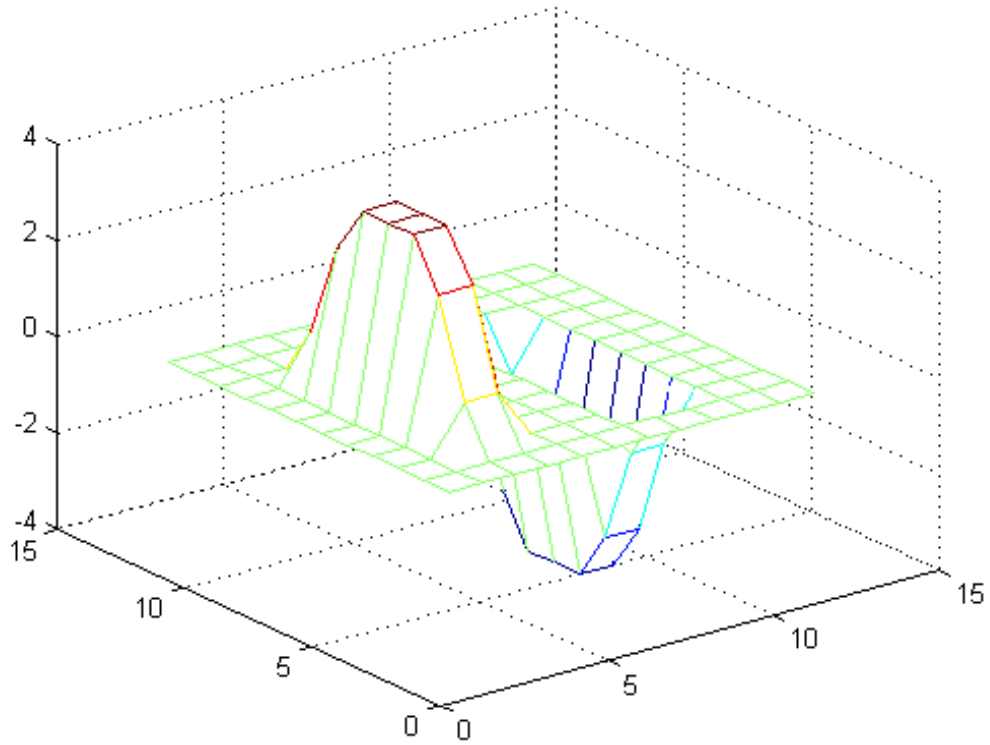

This figure combines both horizontal and vertical edges.

```
figure  
mesh(sqrt(H.^2 + V.^2))
```

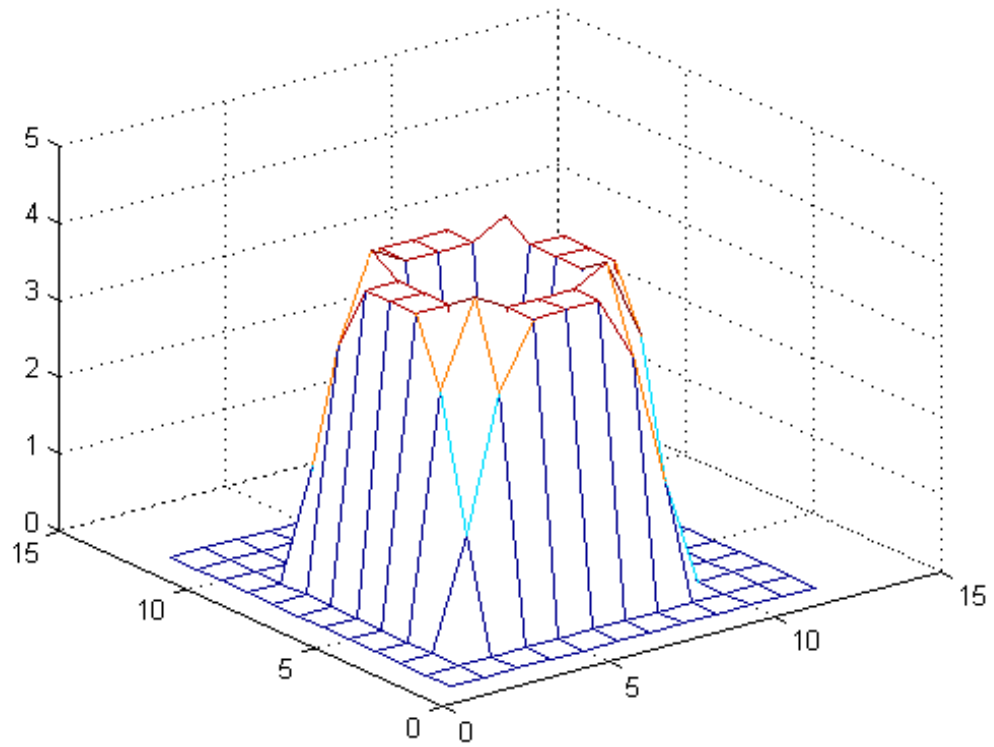
**See Also**

[conv](#) | [convn](#) | [filter2](#) | [xcorr2](#)

convhull

Purpose Convex hull

Note Qhull-specific options are no longer supported. Remove the `OPTIONS` argument from all instances in your code that pass it to `convhull`.

Syntax

```
K = convhull(X,Y)
K = convhull(X,Y,Z)
K = convhull(X)
K = convhull(...,'simplify', logicalvar)
[K,V] = convhull(...)
```

Definitions `convhull` returns the convex hull of a set of points in 2-D or 3-D space.

Description

`K = convhull(X,Y)` returns the 2-D convex hull of the points (X,Y), where X and Y are column vectors. The convex hull K is expressed in terms of a vector of point indices arranged in a counterclockwise cycle around the hull.

`K = convhull(X,Y,Z)` returns the 3-D convex hull of the points (X,Y,Z), where X, Y, and Z are column vectors. K is a triangulation representing the boundary of the convex hull. K is of size `mtri-by-3`, where `mtri` is the number of triangular facets. That is, each row of K is a triangle defined in terms of the point indices.

`K = convhull(X)` returns the 2-D or 3-D convex hull of the points X. This variant supports the definition of points in matrix format. X is of size `mpts-by-ndim`, where `mpts` is the number of points and `ndim` is the dimension of the space where the points reside, $2 \leq \text{ndim} \leq 3$. The output facets are equivalent to those generated by the 2-input or 3-input calling syntax.

`K = convhull(...,'simplify', logicalvar)` provides the option of removing vertices that do not contribute to the area/volume of the convex hull, the default is false. Setting 'simplify' to true returns the topology in a more concise form.

`[K,V] = convhull(...)` returns the convex hull `K` and the corresponding area/volume `V` bounded by `K`.

Visualization Use `plot` to plot the output of `convhull` in 2-D. Use `trisurf` or `trimesh` to plot the output of `convhull` in 3-D.

Examples **Plot 2-D Convex Hull**

```
xx = -1:.05:1; yy = abs(sqrt(xx));  
[x,y] = pol2cart(xx,yy);  
k = convhull(x,y);  
plot(x(k),y(k),'r-',x,y,'b+')
```

convhull

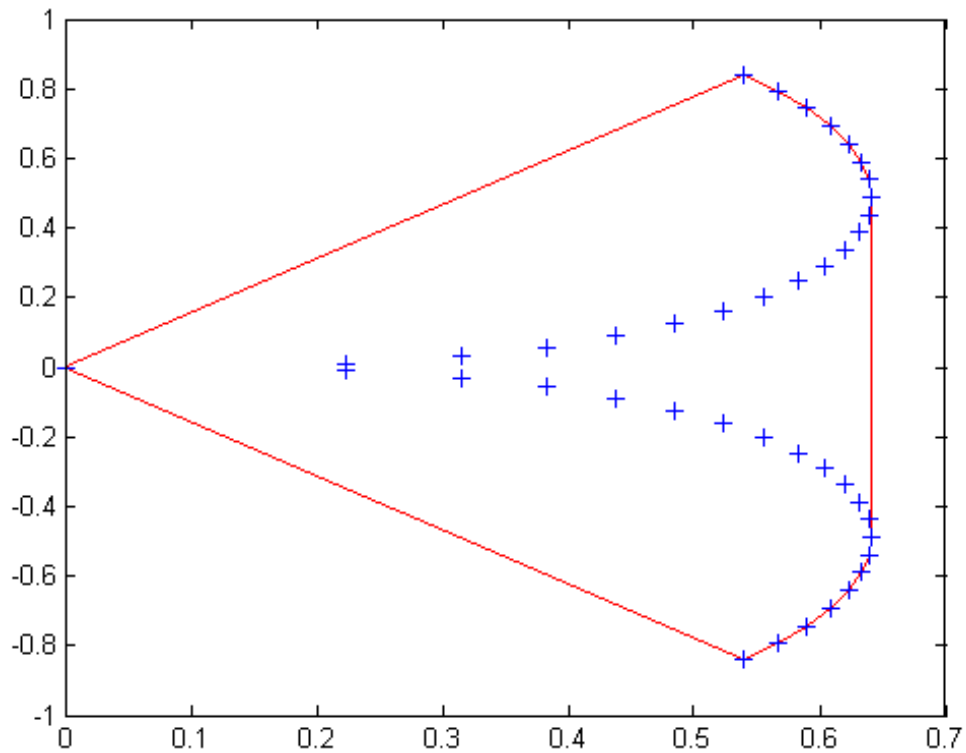

See Also

[convexHull](#) | [voronoiDiagram](#) | [convhulln](#) | [delaunay](#) | [polyarea](#)
| [voronoi](#)

Purpose	N-D convex hull
Syntax	<pre>K = convhulln(X) K = convhulln(X, options) [K, v] = convhulln(...)</pre>
Description	<p><code>K = convhulln(X)</code> returns the indices <code>K</code> of the points in <code>X</code> that comprise the facets of the convex hull of <code>X</code>. <code>X</code> is an <code>m</code>-by-<code>n</code> array representing <code>m</code> points in <code>N</code>-dimensional space. If the convex hull has <code>p</code> facets then <code>K</code> is <code>p</code>-by-<code>n</code>.</p> <p><code>convhulln</code> uses <code>Qhull</code>.</p> <p><code>K = convhulln(X, options)</code> specifies a cell array of strings <code>options</code> to be used as options in <code>Qhull</code>. The default options are:</p> <ul style="list-style-type: none"> • <code>{'Qt'}</code> for 2-, 3-, and 4-dimensional input • <code>{'Qt', 'Qx'}</code> for 5-dimensional input and higher. <p>If <code>options</code> is <code>[]</code>, the default options are used. If <code>options</code> is <code>{''}</code>, no options are used, not even the default. For more information on <code>Qhull</code> and its options, see http://www.qhull.org/.</p> <p><code>[K, v] = convhulln(...)</code> also returns the volume <code>v</code> of the convex hull.</p>
Visualization	<p>Plotting the output of <code>convhulln</code> depends on the value of <code>n</code>:</p> <ul style="list-style-type: none"> • For <code>n = 2</code>, use <code>plot</code> as you would for <code>convhull</code>. • For <code>n = 3</code>, you can use <code>trisurf</code> to plot the output. The calling sequence is <pre>K = convhulln(X); trisurf(K,X(:,1),X(:,2),X(:,3))</pre> • You cannot plot <code>convhulln</code> output for <code>n > 3</code>.
Examples	The following example illustrates the options input for <code>convhulln</code> . The following commands

convhulln

```
X = [0 0; 0 1e-10; 0 0; 1 1];  
K = convhulln(X)
```

return a warning.

```
Warning: qhull precision warning:  
The initial hull is narrow  
(cosine of min. angle is 0.9999999999999998).  
A coplanar point may lead to a wide facet.  
Options 'QbB' (scale to unit box) or 'Qbb'  
(scale last coordinate) may remove this warning.  
Use 'Pp' to skip this warning.
```

To suppress the warning, use the option 'Pp'. The following command passes the option 'Pp', along with the default 'Qt', to convhulln.

```
K = convhulln(X,{'Qt','Pp'})
```

```
K =
```

```
   1   4  
   1   2  
   4   2
```

Algorithms

convhulln is based on Qhull [1]. For information about Qhull, see <http://www.qhull.org/>. For copyright information, see <http://www.qhull.org/COPYING.txt>.

References

[1] Barber, C. B., D.P. Dobkin, and H.T. Huhdanpaa, "The Quickhull Algorithm for Convex Hulls," *ACM Transactions on Mathematical Software*, Vol. 22, No. 4, Dec. 1996, p. 469-483.

See Also

convexHull | convhull | delaunayn | dsearchn | tsearchn | voronoin

Purpose	N-D convolution						
Syntax	<code>C = convn(A,B)</code> <code>C = convn(A,B, 'shape')</code>						
Description	<p><code>C = convn(A,B)</code> computes the N-dimensional convolution of the arrays A and B. The size of the result is <code>size(A)+size(B)-1</code>.</p> <p><code>C = convn(A,B, 'shape')</code> returns a subsection of the N-dimensional convolution, as specified by the shape parameter:</p> <table><tr><td><code>'full'</code></td><td>Returns the full N-dimensional convolution (default).</td></tr><tr><td><code>'same'</code></td><td>Returns the central part of the result that is the same size as A.</td></tr><tr><td><code>'valid'</code></td><td>Returns only those parts of the convolution that can be computed without assuming that the array A is zero-padded. The size of the result is <code>max(size(A)-size(B) + 1, 0)</code></td></tr></table>	<code>'full'</code>	Returns the full N-dimensional convolution (default).	<code>'same'</code>	Returns the central part of the result that is the same size as A.	<code>'valid'</code>	Returns only those parts of the convolution that can be computed without assuming that the array A is zero-padded. The size of the result is <code>max(size(A)-size(B) + 1, 0)</code>
<code>'full'</code>	Returns the full N-dimensional convolution (default).						
<code>'same'</code>	Returns the central part of the result that is the same size as A.						
<code>'valid'</code>	Returns only those parts of the convolution that can be computed without assuming that the array A is zero-padded. The size of the result is <code>max(size(A)-size(B) + 1, 0)</code>						
See Also	<code>conv</code> <code>conv2</code>						

matlab.mixin.CustomDisplay

Purpose Display customization interface class

Description This class provides an interface for customizing the MATLAB display of objects. Derive your class from `matlab.mixin.CustomDisplay` to add the custom display functionality to your class.

`matlab.mixin.CustomDisplay` implements three public sealed methods. `disp` and `display` provide a simple object display. The `details` method provides a standard formal display of object information.

For customizing object display, `matlab.mixin.CustomDisplay` defines a number of protected methods that you can override in your subclass. By overriding specific methods, you can customize specific aspects of the object display.

Methods

<code>convertDimensionsToString</code>	Return array dimensions as string
<code>details</code>	Fully detailed formal object display
<code>disp</code>	Simple informal object display
<code>display</code>	Print variable name and display object
<code>displayEmptyObject</code>	Display for empty object arrays
<code>displayNonScalarObject</code>	Display format for non-scalar objects
<code>displayPropertyGroups</code>	Display titles and property groups as defined
<code>displayScalarHandleToDeletedObject</code>	Display format for deleted scalar handles
<code>displayScalarObject</code>	Display format for scalar objects
<code>getClassNameForHeader</code>	Return class name for display

<code>getDeletedHandleText</code>	Returns text for handle to deleted object display
<code>getDetailedFooter</code>	Returns default detailed footer for object display
<code>getDetailedHeader</code>	Returns default detailed header for object display
<code>getFooter</code>	Build and return display footer text
<code>getHandleText</code>	Return string 'handle' with link to documentation
<code>getHeader</code>	Build and return display header text
<code>getPropertyGroups</code>	Construct array of property groups
<code>getSimpleHeader</code>	Return simple header for object display

Attributes

Abstract	This class defines an interface that subclasses inherit. You cannot instantiate this class.
HandleCompatible	You can use this class to derive both handle and value classes.

See Also `matlab.mixin.util.PropertyGroup`

Related Examples

- “Custom Display Interface”

matlab.mixin.CustomDisplay.convertDimensionsToString

Purpose	Return array dimensions as string								
Syntax	<pre>dimstr = matlab.mixin.CustomDisplay.convertDimensionsToString(obj)</pre>								
Description	<pre>dimstr = matlab.mixin.CustomDisplay.convertDimensionsToString(obj)</pre> converts a size vector into a properly formatted string of dimensions for the nonscalar header.								
Input Arguments	obj MATLAB object								
Output Arguments	dimstr String representing the object's dimensions as determined by calling <code>size</code> .								
Attributes	<table><tr><td>Static</td><td>true</td></tr><tr><td>Access</td><td>Protected</td></tr><tr><td>Sealed</td><td>true</td></tr><tr><td>Hidden</td><td>true</td></tr></table> <p>To learn about attributes of methods, see Method Attributes in the MATLAB Object-Oriented Programming documentation.</p>	Static	true	Access	Protected	Sealed	true	Hidden	true
Static	true								
Access	Protected								
Sealed	true								
Hidden	true								
See Also	<code>matlab.mixin.CustomDisplay.getHeader</code>								
Related Examples	<ul style="list-style-type: none">“Custom Display Interface”								

Purpose Fully detailed formal object display

Syntax `details(obj)`

Description `details(obj)` displays the detailed state of `obj`. The detailed display is not affected by customizations made to classes derived from `matlab.mixin.CustomDisplay`.

Attributes

Access = public	You can call <code>details</code> on any object that is a class derived from <code>matlab.mixin.CustomDisplay</code> .
Sealed	You cannot override the <code>details</code> method in your subclass of <code>matlab.mixin.CustomDisplay</code> .

Input Arguments

obj

Instance of a class derived from `matlab.mixin.CustomDisplay`.

Default: none

Examples

Suppose `EmployeeInfo` is a subclass of `matlab.mixin.CustomDisplay`

```
details(e1)
```

`EmployeeInfo handle` with properties:

```
Name: 'Bill Tork'  
JobTitle: 'Software Engineer'  
Department: 'Product Development'  
Salary: 1000  
Password: 'bill123'
```

[Methods, Events, Superclasses](#)

matlab.mixin.CustomDisplay.details

See Also

disp | display

Related Examples

- “Custom Display Interface”

Purpose Simple informal object display

Syntax `disp(obj)`

Description `disp(obj)` displays the contents of `obj` in one of four simple formats, based on the state of `obj`.

- Handle to deleted object
- Empty object array
- Scalar
- Nonscalar

To customize a display format, override one or more of the four handler methods.

Input Arguments

obj

Object of a class derived from `matlab.mixin.CustomDisplay`

Attributes

Access	public
Sealed	true

To learn about attributes of methods, see Method Attributes in the MATLAB Object-Oriented Programming documentation.

See Also

`disp` | `details` |
`matlab.mixin.CustomDisplay.displayScalarObject` |
`matlab.mixin.CustomDisplay.displayNonScalarObject` |
`matlab.mixin.CustomDisplay.displayEmptyObject` |
`matlab.mixin.CustomDisplay.displayScalarHandleToDeletedObject`

Related Examples

- “Custom Display Interface”

matlab.mixin.CustomDisplay.display

Purpose Print variable name and display object

Syntax `display(obj)`

Description `display(obj)` prints the name of input argument `obj` as it appears in the workspace of the caller. If there is no assignment to a variable, `display` uses, `ans`. `display` then calls the `disp` method to print the object.

Input Arguments

obj
Object array of a class derived from `matlab.mixin.CustomDisplay`

Attributes

Access	public
Sealed	true

To learn about attributes of methods, see [Method Attributes](#) in the MATLAB Object-Oriented Programming documentation.

See Also `disp` | [details](#)

Related Examples

- “Custom Display Interface”

matlab.mixin.CustomDisplay.displayEmptyObject

Purpose Display for empty object arrays

Syntax `displayEmptyObject(obj)`

Description `displayEmptyObject(obj)` is called by `disp` when the object, `obj`, is empty. An object array is empty if one or more of its dimensions are zero. An empty object array is never scalar.

The default display of an empty object consists of a header and a list of property names. The header consists of the object's dimensions and the properties are shown in the order defined in the class definition. `displayEmptyObject` shows only those properties with `public GetAccess` and `Hidden` set to `false`.

Override this method to customize the appearance of an empty object array.

Input Arguments **obj**
Object of a class derived from `matlab.mixin.CustomDisplay`

Attributes
Access protected

To learn about attributes of methods, see [Method Attributes](#) in the [MATLAB Object-Oriented Programming](#) documentation.

See Also `matlab.mixin.CustomDisplay.displayScalarObject` |
`matlab.mixin.CustomDisplay.displayNonScalarObject` |
`matlab.mixin.CustomDisplay.displayScalarHandleToDeletedObject`

Related Examples

- “Custom Display Interface”

matlab.mixin.CustomDisplay.displayNonScalarObject

Purpose Display format for non-scalar objects

Syntax `displayNonScalarObject(obj)`

Description `displayNonScalarObject(obj)` is called by the `disp` method when the object, `obj`, is nonscalar (`prod(size(obj)) > 1`)

The default display of a nonscalar object array consists of a header and a list of property names. The header consists of the object's dimensions and the properties are shown in the order defined in the class definition. `displayNonScalarObject` shows only those properties with public `GetAccess` and `Hidden` set to `false`.

Override this method to customize the display a nonscalar object array.

Input Arguments

obj
Object array of a class derived from `matlab.mixin.CustomDisplay`

Attributes

Access	protected
--------	-----------

To learn about attributes of methods, see [Method Attributes](#) in the [MATLAB Object-Oriented Programming](#) documentation.

See Also

`matlab.mixin.CustomDisplay.displayScalarObject` |
`matlab.mixin.CustomDisplay.displayEmptyObject` |
`matlab.mixin.CustomDisplay.displayScalarHandleToDeleteObject`

Related Examples

- “Custom Display Interface”

matlab.mixin.CustomDisplay.displayPropertyGroups

Purpose	Display titles and property groups as defined								
Syntax	<code>matlab.mixin.CustomDisplay.displayPropertyGroups(obj, propertyGroupArray)</code>								
Description	<code>matlab.mixin.CustomDisplay.displayPropertyGroups(obj, propertyGroupArray)</code> displays titles and custom property lists as defined by the property groups.								
Input Arguments	<p>obj MATLAB object</p> <p>propertyGroupArray Array of <code>matlab.mixin.util.PropertyGroup</code> objects.</p>								
Attributes	<table><tr><td>Static</td><td>true</td></tr><tr><td>Access</td><td>Protected</td></tr><tr><td>Sealed</td><td>true</td></tr><tr><td>Hidden</td><td>true</td></tr></table> <p>To learn about attributes of methods, see Method Attributes in the MATLAB Object-Oriented Programming documentation.</p>	Static	true	Access	Protected	Sealed	true	Hidden	true
Static	true								
Access	Protected								
Sealed	true								
Hidden	true								
See Also	<code>PropertyGroup</code>								
Related Examples	<ul style="list-style-type: none">“Custom Display Interface”								

matlab.mixin.CustomDisplay.displayScalarHandleToDeletedOb

Purpose Display format for deleted scalar handles

Syntax `displayScalarHandleToDeletedObject(obj)`

Description `displayScalarHandleToDeletedObject(obj)` is called by the `disp` method when `obj` is:

- An instance of a handle class
- Scalar
- A handle to a deleted object

That is, the following expression is true.

```
isa(obj, 'handle') && isscalar(obj) && ~isvalid(obj)
```

Override this method to customize the appearance of your object's display when it is deleted.

Input Arguments

obj

Object of a class derived from `matlab.mixin.CustomDisplay`

Attributes

Access

protected

To learn about attributes of methods, see [Method Attributes](#) in the [MATLAB Object-Oriented Programming](#) documentation.

See Also

`matlab.mixin.CustomDisplay.displayScalarObject` |
`matlab.mixin.CustomDisplay.displayNonScalarObject` |
`matlab.mixin.CustomDisplay.displayEmptyObject`

Related Examples

- “Custom Display Interface”

matlab.mixin.CustomDisplay.displayScalarObject

Purpose Display format for scalar objects

Syntax `displayScalarObject(obj)`

Description `displayScalarObject(obj)` is called by the `disp` method when the object, `obj`, is scalar (`prod(size(obj)) == 1`).

The default display of a scalar object consists of a header and a list of properties and their values. Properties are shown in the order they are defined in the class definition. `displayScalarObject` shows only those properties with `public GetAccess` and `Hidden` set to `false`.

Override this method to customize the display of a scalar object.

Input Arguments

obj
Object of a class derived from `matlab.mixin.CustomDisplay`

Attributes

Access protected

To learn about attributes of methods, see [Method Attributes](#) in the [MATLAB Object-Oriented Programming](#) documentation.

See Also `matlab.mixin.CustomDisplay.displayNonScalarObject` |
`matlab.mixin.CustomDisplay.displayEmptyObject` |
`matlab.mixin.CustomDisplay.displayScalarHandleToDeletedObject`

Related Examples

- “Custom Display Interface”

matlab.mixin.CustomDisplay.getClassNameForHeader

Purpose Return class name for display

Syntax `name = matlab.mixin.CustomDisplay.getClassNameForHeader(obj)`

Description `name = matlab.mixin.CustomDisplay.getClassNameForHeader(obj)` returns the class name of `obj`. If the display supports hypertext links, the text is linked to the help for the class of `obj`.

Use this method when building a custom display that includes the class name, but differs from the default header.

Input Arguments **obj**
MATLAB object

Output Arguments **name**
The simple class name, linked to the help for the class if the display supports hypertext links

Attributes	Static	true
	Access	Protected
	Sealed	true
	Hidden	true

To learn about attributes of methods, see Method Attributes in the MATLAB Object-Oriented Programming documentation.

See Also `getHeader`

Related Examples

- “Custom Display Interface”

matlab.mixin.CustomDisplay.getDeletedHandleText

Purpose Returns text for handle to deleted object display

Syntax `handleText = matlab.mixin.CustomDisplay.getDeletedHandleText`

Description `handleText = matlab.mixin.CustomDisplay.getDeletedHandleText` returns the text:

`'handle to deleted'`

The text is linked to the documentation on deleted handle objects.

Output Arguments **handleText**
String 'handle to deleted', linked if the display supports hypertext links

Attributes	Static	true
	Access	Protected
	Sealed	true
	Hidden	true

To learn about attributes of methods, see Method Attributes in the MATLAB Object-Oriented Programming documentation.

See Also `getHeader`

Related Examples

- “Custom Display Interface”

matlab.mixin.CustomDisplay.getDetailedFooter

Purpose Returns default detailed footer for object display

Syntax `headerText = matlab.mixin.CustomDisplay.getDetailedFooter(obj)`

Description `headerText = matlab.mixin.CustomDisplay.getDetailedFooter(obj)` returns the string containing:

[Methods](#), [Events](#), [Superclass](#)

Each link executes the respective command on `obj`.

Input Arguments **obj**
MATLAB object

Output Arguments **headerText**
String containing the linked phrase 'Methods, Events, Superclasses' or the empty string if the display does not support hypertext links

Attributes

Static	true
Access	Protected
Sealed	true
Hidden	true

To learn about attributes of methods, see Method Attributes in the MATLAB Object-Oriented Programming documentation.

See Also [methods](#) | [events](#) | [superclasses](#) | [getFooter](#)

Related Examples

- “Custom Display Interface”

matlab.mixin.CustomDisplay.getDetailedHeader

Purpose	Returns default detailed header for object display								
Syntax	<code>header = matlab.mixin.CustomDisplay.getDetailedHeader(obj)</code>								
Description	<p><code>header = matlab.mixin.CustomDisplay.getDetailedHeader(obj)</code> returns a string containing:</p> <ul style="list-style-type: none">• Linked class name of <code>obj</code>• Link to handle documentation if <code>obj</code> is a handle class• The string 'with properties:'								
Input Arguments	<p>obj MATLAB object</p>								
Output Arguments	<p>header String containing the full detailed header, with properly inserted links if the display supports hypertext linking</p>								
Attributes	<table><tr><td>Static</td><td>true</td></tr><tr><td>Access</td><td>Protected</td></tr><tr><td>Sealed</td><td>true</td></tr><tr><td>Hidden</td><td>true</td></tr></table> <p>To learn about attributes of methods, see Method Attributes in the MATLAB Object-Oriented Programming documentation.</p>	Static	true	Access	Protected	Sealed	true	Hidden	true
Static	true								
Access	Protected								
Sealed	true								
Hidden	true								
See Also	<code>handle</code> <code>details</code>								
Related Examples	<ul style="list-style-type: none">• “Custom Display Interface”								

matlab.mixin.CustomDisplay.getFooter

Purpose Build and return display footer text

Syntax `s = getFooter(obj)`

Description `s = getFooter(obj)` returns the text used as the footer when displaying `obj`. This method is called once for the entire object array.

Override this method to create a custom footer. The overriding implementation must support all states of the object, including scalar, nonscalar, empty, and deleted (if `obj` is an instance of a handle class).

Input Arguments

obj Object array of a class derived from `matlab.mixin.CustomDisplay`

Output Arguments

s Footer text, returned as a string.
The default implementation returns an empty string

Attributes

Access protected

To learn about attributes of methods, see Method Attributes in the MATLAB Object-Oriented Programming documentation.

See Also `matlab.mixin.CustomDisplay.getHeader` | `matlab.mixin.CustomDisplay.getPropertyGroups`

Related Examples

- “Custom Display Interface”

matlab.mixin.CustomDisplay.getHandleText

Purpose Return string 'handle' with link to documentation

Syntax `handleText = matlab.mixin.CustomDisplay.getHandleText`

Description `handleText = matlab.mixin.CustomDisplay.getHandleText` returns the string 'handle'. If the display supports hypertext linking, the text is linked to documentation describing handle classes.

Output Arguments

handleText
String 'handle', linked to the handle documentation.

Attributes

Static	true
Access	Protected
Sealed	true
Hidden	true

To learn about attributes of methods, see Method Attributes in the MATLAB Object-Oriented Programming documentation.

See Also `getHeader`

Related Examples

- “Custom Display Interface”

matlab.mixin.CustomDisplay.getHeader

Purpose	Build and return display header text
Syntax	<code>s = getHeader(obj)</code>
Description	<p><code>s = getHeader(obj)</code> returns the text used as the header when displaying <code>obj</code>. This method is called once for the entire object array.</p> <p>Override this method to create a custom header. The overriding implementation must support all states of the object, including scalar, nonscalar, empty, and deleted (if <code>obj</code> is an instance of a handle class).</p>
Input Arguments	<p>obj</p> <p>Object array of a class derived from <code>matlab.mixin.CustomDisplay</code></p>
Output Arguments	<p>s</p> <p>Header string, returned as a char array</p> <p>The default implementation returns the following:</p> <ul style="list-style-type: none">• If <code>obj</code> is scalar, returns <code>classname</code>, which is the simple name of the class (the nonpackage-qualified name).• If <code>obj</code> is nonscalar, returns <code>classname</code> and dimensions.• If <code>obj</code> is empty, returns an empty string.• If <code>obj</code> is a deleted handle, returns the string <code>deleted classname handle</code> <p><code>classname</code> is linked to MATLAB documentation for the class. Selecting the link displays the <code>helpPopup</code> window.</p> <p>If you override this method, you might need to terminate <code>s</code> with a newline (<code>\n</code>) character.</p>
Examples	<p>Append Text to Default Header</p> <p>Append the string, 'with Customized Display', to the header text.</p>

Write a `getHeader` method.

```
methods (Access = protected)
    function header = getHeader(obj)
        if ~isscalar(obj)
            header = getHeader@matlab.mixin.CustomDisplay(obj);
        else
            headerStr = matlab.mixin.CustomDisplay.getClassNameForHeader(obj);
            headerStr = [headerStr, ' with Customized Display'];
            header = sprintf('%s\n',headerStr);
        end
    end
end
```

Add `getHeader` method to class definition.

Attributes

Access protected

To learn about attributes of methods, see [Method Attributes in the MATLAB Object-Oriented Programming documentation](#).

See Also

[matlab.mixin.CustomDisplay.getFooter](#) |
[matlab.mixin.CustomDisplay.getPropertyGroups](#)

Related Examples

- “Custom Display Interface”

matlab.mixin.CustomDisplay.getPropertyGroups

Purpose Construct array of property groups

Syntax `groups = getPropertyGroups(obj)`

Description `groups = getPropertyGroups(obj)` returns an array of `matlab.mixin.util.PropertyGroup` objects. MATLAB displays property groups separated by blank spaces.

Each default display state handler method calls this method once. The default implementation returns the properties in one group. These properties must have public `GetAccess` and not be defined as `Hidden`. If the object is scalar, MATLAB includes dynamic properties.

Override this method to construct one or more customized groups of properties to display.

Each group object array has the following fields:

- **Title** — String used as the header for the property group or an empty string if no title is used.
- **PropertyList** — The property list can be either:
 - A 1-by-1 struct of property name-property value pairs
 - A cell array of string property names.

Use the struct of name-value pairs if the object is scalar and you want to assign custom property values. Otherwise, use a cell array of string property names. If the object is scalar MATLAB adds the property values retrieved from the object.

Input Arguments **obj**
Object array of a class derived from `matlab.mixin.CustomDisplay`

Output Arguments **groups**
1xN array of `matlab.mixin.util.PropertyGroup` objects, where N is the number of groups

matlab.mixin.CustomDisplay.getPropertyGroups

Examples

Custom Property Group

Customize the values returned by some properties.

Write a `getPropertyGroups` method.

```
methods (Access = protected)
    function propgrp = getPropertyGroups(obj)
        if ~isscalar(obj)
            propgrp = getPropertyGroups@matlab.mixin.CustomDisplay(obj);
        else
            pd(1:length(obj.Password)) = '*';
            propList = struct('Department',obj.Department,...
                'JobTitle',obj.JobTitle,...
                'Name',obj.Name,...
                'Salary','Not available',...
                'Password',pd);
            propgrp = matlab.mixin.util.PropertyGroup(propList);
        end
    end
end
```

Add function to class definition.

Attributes

Access protected

To learn about attributes of methods, see [Method Attributes](#) in the MATLAB Object-Oriented Programming documentation.

See Also

[matlab.mixin.util.PropertyGroup](#) |
[matlab.mixin.CustomDisplay.getHeader](#) |
[matlab.mixin.CustomDisplay.getFooter](#)

Related Examples

- “Custom Display Interface”
- “Customize Property Display”

matlab.mixin.CustomDisplay.getSimpleHeader

Purpose	Return simple header for object display								
Syntax	<code>header = matlab.mixin.CustomDisplay.getSimpleHeader(obj)</code>								
Description	<code>header = matlab.mixin.CustomDisplay.getSimpleHeader(obj)</code> returns the default simple header for Obj.								
Input Arguments	obj MATLAB object.								
Output Arguments	header String containing the linked class name and the phrase 'with properties'								
Attributes	<table><tr><td>Static</td><td>true</td></tr><tr><td>Access</td><td>Protected</td></tr><tr><td>Sealed</td><td>true</td></tr><tr><td>Hidden</td><td>true</td></tr></table> <p>To learn about attributes of methods, see Method Attributes in the MATLAB Object-Oriented Programming documentation.</p>	Static	true	Access	Protected	Sealed	true	Hidden	true
Static	true								
Access	Protected								
Sealed	true								
Hidden	true								
See Also	<code>matlab.mixin.CustomDisplay.getHeader</code>								
Related Examples	<ul style="list-style-type: none">“Custom Display Interface”								

Purpose

Superclass providing copy functionality for handle objects

Description

The `matlab.mixin.Copyable` class is an abstract handle class that provides a copy method for copying handle objects. The copy method makes a shallow copy of the object (that is, it shallow copies all non-dependent properties from the source to the destination object). In making a shallow copy, MATLAB does not call copy recursively on any handles contained in property values.

Subclass `matlab.mixin.Copyable` when you want to define handles classes that inherit a copy method. The copy method:

- Copies data without calling class constructors or property set functions and therefore produces no side effects.
- Enables subclasses to customize the copy behavior

Customizing Subclass Copy Behavior

The copy method provides the public, non-overrideable interface to copy behavior. `copy` takes an array of objects as input and returns an array of the same shape and dimensions.

`copyElement` is a protected method that the copy method uses to perform the copy operation on each object in the input array. `copyElement` is not `Sealed` so you can override it in your subclass to customize the behavior of the inherited copy method.

Implementing a Selective Deep Copy

This example overrides the `copyElement` method in a subclass of `matlab.mixin.Copyable` to implement a deep copy of a specific class of handle objects.

Consider the following classes:

- `ContainsHandles` — subclass of `matlab.mixin.Copyable` that contains handle objects in two properties
- `DeepCp` — subclass of `matlab.mixin.Copyable`
- `ShallowCp` — subclass of `handle`

matlab.mixin.Copyable

Here are the simplified class definitions:

```
classdef ContainsHandles < matlab.mixin.Copyable
    properties
        Prop1
        Prop2
        DeepObj    % Contains a DeepCp object
        ShallowObj % Contains a ShallowCp object
    end
    methods
        function obj = ContainsHandles(val1, val2, deepobj, shallowobj)
            if nargin > 0
                obj.Prop1 = val1;
                obj.Prop2 = val2;
                obj.DeepObj = deepobj;
                obj.ShallowObj = shallowobj;
            end
        end
    end
    methods(Access = protected)
        % Override copyElement method:
        function cpObj = copyElement(obj)
            % Make a shallow copy of all four properties
            cpObj = copyElement@matlab.mixin.Copyable(obj);
            % Make a deep copy of the DeepCp object
            cpObj.DeepObj = copy(obj.DeepObj);
        end
    end
end
```

The DeepCp class derives from matlab.mixin.Copyable:

```
classdef DeepCp < matlab.mixin.Copyable
    properties
        DpProp
    end
    methods
        function obj = DeepCp(val)
```

```
        ...
        end
    end
end
```

The handle class `ShallowCp` does not derive from `matlab.mixin.Copyable` and, therefore, has no copy method:

```
classdef ShallowCp < handle
    properties
        ShProp
    end
    methods
        function obj = ShallowCp(val)
            ...
        end
    end
end
```

Create a `ContainsHandles` object, which contains the two handle objects in its `DpProp` and `ShProp` properties:

```
>> sc = ShallowCp(7);
>> dc = DeepCp(7);
>> a = ContainsHandles(4,5,dc,sc);
>> a.DeepObj
ans =
```

DeepCp with properties:

```
    DpProp: 7
>> a.ShallowObj.ShProp
ans =
```

ShallowCp with properties:

```
    ShProp: 7
```

matlab.mixin.Copyable

Make a copy of the `ContainsHandles` object:

```
>> b = copy(a);
```

The returned copy `b` contains a shallow copy of object `sc`, and a deep copy of object `dc`. That is, the `dc` object passed to `ContainsHandles` constructor is now a new, independent objects as a result of the copy operation. You can now change the `dc` object without affecting the copy. This is not the case for the shallow copied object, `sc`:

```
% Change the property values of the handle objects:
```

```
>> sc.ShProp = 5;
```

```
>> dc.DpProp = 5;
```

```
% Note that the deep copied object is not affected:
```

```
>> b.DeepObj
```

```
ans =
```

```
    DeepCp with properties:
```

```
        DpProp: 7
```

```
% The shallow copied object is still referencing the same data:
```

```
>> b.ShallowObj
```

```
ans =
```

```
    ShallowCp with properties:
```

```
        ShProp: 5
```

Overriding Copy Behavior in Hierarchies

The `copyElement` method in a superclass cannot access the private data in a subclass.

If you override `copyElement` in a subclass of `matlab.mixin.Copyable`, and then use this subclass as a superclass, you need to override `copyElement` in all subclasses that contain private properties. The

override of `copyElement` in subclasses should call the `copyElement` in the respective superclass, as in the previous example.

The following simplified code demonstrates this approach:

```
classdef SuperClass < matlab.mixin.Copyable
    properties(Access = private)
        super_prop
    end
    methods
        ...

        function cpObj = copyElement(obj)
            ...
            cpObj = copyElement@matlab.mixin.Copyable(obj);
            ...
        end
    end
end

classdef SubClass1 < SuperClass
    properties(Access=private)
        sub_prop1
    end
    methods
        function cpObj = copyElement(obj)
            % Copy super_prop
            cpObj = copyElement@SuperClass(obj);
            % Copy sub_prop1 in subclass
            % Assignment can introduce side effects
            cpObj.sub_prop1 = obj.sub_prop1;
        end
    end
end
```

The override of `copyElement` in `SubClass1` copies the private subclass property because the superclass cannot access private data in the subclass.

Note The assignment of `sub_prop1` in the override of `copyElement` in `SubClass1` calls the property set method, if one exists, possibly introducing side effects to the copy operation.

Copy Behaviors for Specific Inputs

Given a call to the `matlab.mixin.Copyable` `copy` method of the form:

```
B = copy(A);
```

Under the following conditions, produces the described results:

- A has dynamic properties — `copy` does not copy dynamic properties. You can implement dynamic-property copying in the subclass if needed.
- A has no non-Dependent properties — `copy` creates a new object with no property values without calling the class constructor to avoid introducing side effects.
- A contains deleted handles — `copy` creates deleted handles of the same class in the output array.
- A has attached listeners — `copy` does not copy listeners.
- A contains objects of enumeration classes — Enumeration classes cannot subclass `matlab.mixin.Copyable`.
- A `delete` method calls `copy` — `copy` creates a legitimate copy, obeying all the behaviors that apply in any other usage.

Note You cannot derive an enumeration class from `matlab.mixin.Copyable` because the number of instances you can create are limited to the ones defined inside the enumeration block. See “Working with Enumerations” for more information about enumeration classes.

Methods

`copy` Copy array of handle objects

Definitions

Deep Copy

Copy each property value and assign it to the new (copied) property. Recursively copy property values that reference handle objects to copy all of the underlying data.

Shallow Copy

Copy each property value and assign it to the new (copied) property. If a property value is a handle, copy the handle but not the underlying data.

Attributes

`ConstructOnLoad` true

To learn about attributes of classes, see Class Attributes in the MATLAB Object-Oriented Programming documentation.

Copy Semantics

Handle. To learn how handle classes affect copy operations, see Copying Objects in the MATLAB documentation.

See Also

`handle`

How To

- Class Attributes

matlab.mixin.Copyable.copy

Purpose Copy array of handle objects

Syntax `B = copy(A)`

Description `B = copy(A)` copies each element in the array of handles `A` to the new array of handles `B`.

The copy method performs a copy according to the following rules:

- The copy method does not copy Dependent properties
- MATLAB does not call the copy method recursively on any handles contained in property values
- MATLAB does not call the class constructor or property set methods during the copy operation.
- `B` has the same number of elements and same size as `A`.
- `B` is the same class as `A`.
- If `A` is empty, `B` is also empty.
- If `A` is heterogeneous, `B` is also heterogeneous.
- If `A` contains deleted handle objects, copy creates deleted handles of the same class in `B`.
- Dynamic properties and listeners associated with objects in `A` are not copied to objects in `B`.
- You can call `copy` inside your class `delete` method.

Input Arguments **A**
Handle object array

Output Arguments **B**
Handle object array containing copies of the objects in `A`.

Attributes

Sealed true

To learn about attributes of methods, see Method Attributes in the MATLAB Object-Oriented Programming documentation.

See Also

[matlab.mixin.Copyable](#) | [handle](#) | [copyElement](#)

copyfile

Purpose

Copy file or folder

Syntax

```
copyfile('source','destination')
copyfile('source','destination','f')
[status] = copyfile(___)
[status, message] = copyfile(___)
[status,message,messageid] = copyfile(___)
```

Description

`copyfile('source','destination')` copies the file or folder named `source` to the file or folder `destination`. The values for `source` and `destination` are 1 x n strings. Use full path names or path names relative to the current folder. To copy multiple files or folders, use one or more wildcard characters (*) after the last file separator in `source`. You cannot use a wildcard character in `destination`.

`copyfile('source','destination','f')` copies `source` to `destination`, even when `destination` is not writable. The state of the read-write attribute for `destination` does not change. You can use `f` with any syntax for `copyfile`.

`[status] = copyfile(___)` reports the outcome as a logical scalar, `status`. The value is 1 for success and 0 for failure.

`[status, message] = copyfile(___)` returns any warning or error message as a string to `message`. When `copyfile` succeeds, `message` is an empty string.

`[status,message,messageid] = copyfile(___)` returns any warning or error identifier as a string to `messageId`. When `copyfile` succeeds, `messageId` is an empty string.

Tips

- The timestamp for `destination` is the same as the timestamp for `source`.
- When `source` is a folder, `destination` must be a folder.
 - When `source` is a folder and `destination` does not exist, `copyfile` creates `destination` and copies the contents of `source` into `destination`.

- When source is a folder and destination is an existing folder, copyfile copies the contents of source into destination.
- When source is multiple files and destination does not exist, copyfile creates destination.

Examples

Copy File to Another Folder

Copy myFun.m from the current folder to d:/work/Projects/.

```
copyfile('myFun.m', 'd:/work/Projects/')
```

Copy File to Its Current Folder

Copy myFun.m in the current folder, assigning it the name myFun2.m.

```
copyfile('myFun.m', 'myFun2.m')
```

Copy Files and Folders to a New Folder Using Wildcards

Copy files and subfolders whose names begin with my, from the Projects subfolder within the current folder to the folder newProjects, which is at the same level as the current folder:

```
copyfile('Projects/my*', '../newProjects/')
```

Copy Files to a New, Nonexistent Folder

Copy the contents of the Projects subfolder within the current folder to the I:/work/newProjects folder, where newProjects does not exist.

```
copyfile('Projects', 'I:/work/newProjects')
```

Copy File that Overwrites a Read-Only File

Copy the contents of myFun.m from the current folder to d:/work/restricted/myFun2.m, where myFun2.m is read-only.

```
[status,message,messageId]=copyfile('myFun.m', ...  
'd:/work/restricted/myFun2.m','f')
```

```
status =  
1
```

copyfile

```
message =  
    ''
```

```
messageId =  
    ''
```

The status of 1 and empty `message` and `messageId` strings confirm the copy was successful.

See Also

`cd` | `delete` | `dir` | `fileattrib` | `filebrowser` | `fileparts` | `mkdir`
| `movefile` | `rmdir`

How To

- “Specify File Names”
- “Manage Files and Folders”

Purpose Copy graphics objects and their descendants

Syntax `new_handle = copyobj(h,p)`

Description `copyobj` creates copies of graphics objects. The copies are identical to the original objects except the copies have different values for their Parent property and a new handle. The new parent must be appropriate for the copied object (e.g., you can copy a line object only to another axes object).

`new_handle = copyobj(h,p)` copies one or more graphics objects identified by `h` and returns the handle of the new object or a vector of handles to new objects. The new graphics objects are children of the graphics objects specified by `p`.

Tips `h` and `p` can be scalars or vectors. When both are vectors, they must be the same length, and the output argument, `new_handle`, is a vector of the same length. In this case, `new_handle(i)` is a copy of `h(i)` with its Parent property set to `p(i)`.

When `h` is a scalar and `p` is a vector, `h` is copied once to each of the parents in `p`. Each `new_handle(i)` is a copy of `h` with its Parent property set to `p(i)`, and `length(new_handle)` equals `length(p)`.

When `h` is a vector and `p` is a scalar, each `new_handle(i)` is a copy of `h(i)` with its Parent property set to `p`. The length of `new_handle` equals `length(h)`.

When programming a GUI, do not call `copyobj` or `textwrap` (which calls `copyobj`) inside a `CreateFcn`. The act of copying the uicontrol object fires the `CreateFcn` repeatedly, which raises a series of error messages after exceeding the root object's `RecursionLimit` property.

Examples Copy a surface to a new axes within a different figure.

```
h = surf(peaks);  
colormap hot  
figure    % Create a new figure
```

```
axes      % Create an axes object in the figure
new_handle = copyobj(h,gca);
colormap hot
view(3)
grid on
```

Note that while the surface is copied, the `colormap` (figure property), `view`, and `grid` (axes properties) are not copied.

See Also

[findobj](#) | [gcf](#) | [gca](#) | [gco](#) | [get](#) | [set](#)

Purpose

Correlation coefficients

Syntax

```
R = corrcoef(X)
R = corrcoef(x,y)
[R,P]=corrcoef(...)
[R,P,RLO,RUP]=corrcoef(...)
[...]=corrcoef(...,'param1',val1,'param2',val2,...)
```

Description

`R = corrcoef(X)` returns a matrix `R` of correlation coefficients calculated from an input matrix `X` whose rows are observations and whose columns are variables. The matrix `R = corrcoef(X)` is related to the covariance matrix `C = cov(X)` by

$$R(i,j) = \frac{C(i,j)}{\sqrt{C(i,i)C(j,j)}}.$$

`corrcoef(X)` is the zeroth lag of the normalized covariance function, that is, the zeroth lag of `xcov(x, 'coeff')` packed into a square array.

`R = corrcoef(x,y)` where `x` and `y` are column vectors is the same as `corrcoef([x y])`. If `x` and `y` are not column vectors, `corrcoef` converts them to column vectors. For example, in this case `R=corrcoef(x,y)` is equivalent to `R=corrcoef([x(:) y(:)])`.

`[R,P]=corrcoef(...)` also returns `P`, a matrix of p-values for testing the hypothesis of no correlation. Each p-value is the probability of getting a correlation as large as the observed value by random chance, when the true correlation is zero. If `P(i,j)` is small, say less than 0.05, then the correlation `R(i,j)` is significant.

`[R,P,RLO,RUP]=corrcoef(...)` also returns matrices `RLO` and `RUP`, of the same size as `R`, containing lower and upper bounds for a 95% confidence interval for each coefficient.

`[...]=corrcoef(...,'param1',val1,'param2',val2,...)` specifies additional parameters and their values. Valid parameters are the following.

'alpha' A number between 0 and 1 to specify a confidence level of $100*(1 - \alpha)\%$. Default is 0.05 for 95% confidence intervals.

'rows' Either 'all' (default) to use all rows, 'complete' to use rows with no NaN values, or 'pairwise' to compute $R(i, j)$ using rows with no NaN values in either column i or j .

The p-value is computed by transforming the correlation to create a t statistic having $n-2$ degrees of freedom, where n is the number of rows of X . The confidence bounds are based on an asymptotic normal distribution of $0.5*\log((1+R)/(1-R))$, with an approximate variance equal to $1/(n-3)$. These bounds are accurate for large samples when X has a multivariate normal distribution. The 'pairwise' option can produce an R matrix that is not positive definite.

Examples

Generate random data having correlation between column 4 and the other columns.

```
x = randn(30,4);        % Uncorrelated data
x(:,4) = sum(x,2);     % Introduce correlation.
[r,p] = corrcoef(x)    % Compute sample correlation and p-values.
[i,j] = find(p<0.05); % Find significant correlations.
[i,j]                 % Display their (row,col) indices.
```

```
r =
    1.0000    -0.3566     0.1929     0.3457
   -0.3566     1.0000    -0.1429     0.4461
    0.1929    -0.1429     1.0000     0.5183
    0.3457     0.4461     0.5183     1.0000
```

```
p =
    1.0000     0.0531     0.3072     0.0613
    0.0531     1.0000     0.4511     0.0135
    0.3072     0.4511     1.0000     0.0033
    0.0613     0.0135     0.0033     1.0000
```



```
ans =  
     4     2  
     4     3  
     2     4  
     3     4
```

See Also

[cov](#) | [mean](#) | [median](#) | [std](#) | [var](#) | [xcorr](#) | [xcov](#)

Purpose Cosine of argument in radians

Syntax `Y = cos(X)`

Description `Y = cos(X)` returns the cosine for each element of `X`. The `cos` function operates element-wise on arrays. The function accepts both real and complex inputs. For purely real values or imaginary values of `X`, `cos` returns real values in the interval `[-1,1]`. For complex values of `X`, `cos` returns complex values. All angles are in radians.

Input Arguments **X - Input angle in radians**
scalar value | vector | matrix | N-D array

Input angle in radians, specified as a real-valued or complex-valued scalar, vector, matrix or N-D array. The `cos` operation is element-wise when `X` is non-scalar.

Data Types

single | double

Complex Number Support: Yes

Output Arguments **Y - Cosine of input angle**
scalar value | vector | matrix | N-D array

Cosine of input angle, returned as a real-valued or complex-valued scalar, vector, matrix or N-D array.

Examples **Plot Cosine Function**

Plot the cosine function over the domain $-\pi \leq x \leq \pi$.

```
x = -pi:0.01:pi;  
plot(x,cos(x)), grid on
```

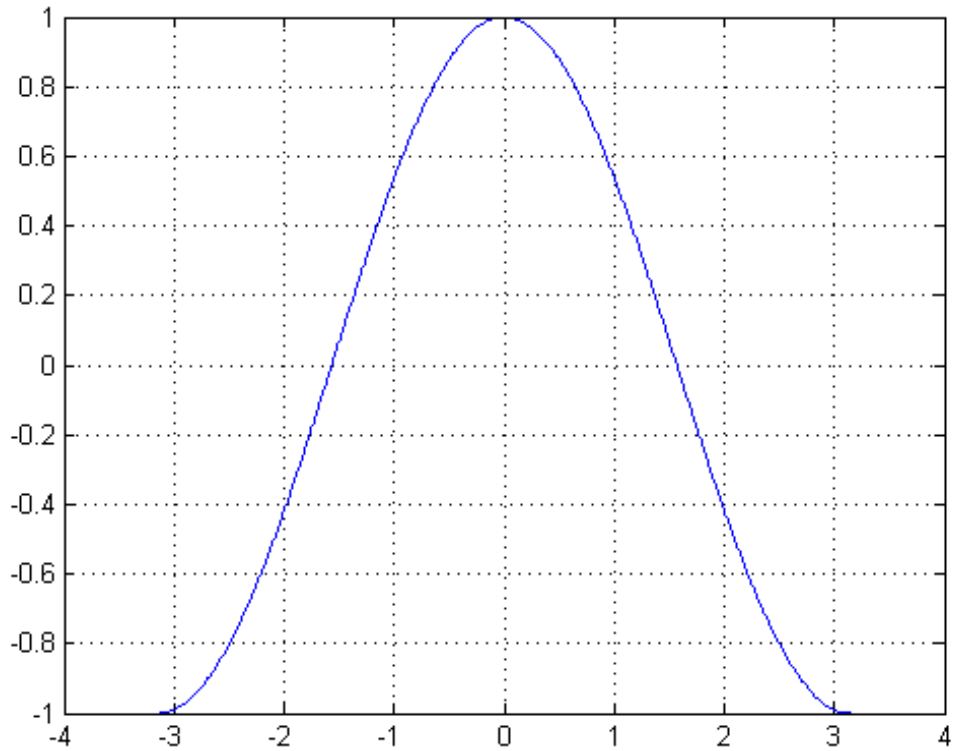

Cosine of Vector of Complex Angles

Calculate the cosine of the complex angles in vector x .

$$x = [-i \pi + i \pi/2 \quad -1 + i 4];$$

$$y = \cos(x)$$

$$y =$$

$$1.5431 + 0.0000i \quad -2.5092 - 0.0000i \quad 14.7547 + 22.9637i$$

Definitions**Cosine Function**

The cosine of an angle, α , defined with reference to a right angled triangle is

$$\text{cosine}(\alpha) = \frac{\text{adjacent side}}{\text{hypotenuse}} = \frac{b}{h}.$$

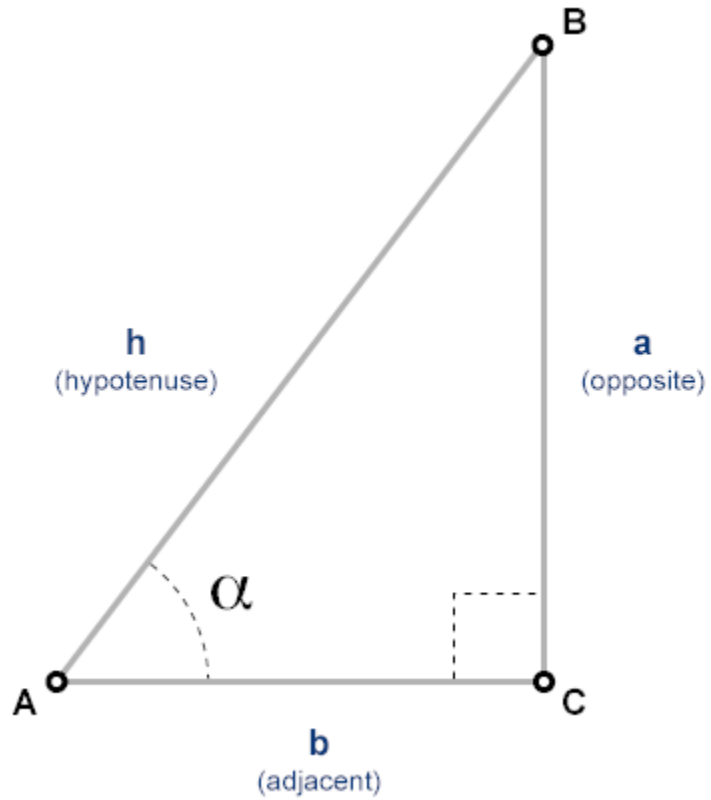

The cosine of a complex angle, α , is

$$\text{cosine}(\alpha) = \frac{e^{i\alpha} + e^{-i\alpha}}{2}.$$

See Also

cosd | acos | acosd | cosh

cosd

Purpose	Cosine of argument in degrees
Syntax	$Y = \text{cosd}(X)$
Description	$Y = \text{cosd}(X)$ returns the cosine of the elements of X , which are expressed in degrees.
Input Arguments	X - Angle in degrees scalar value vector matrix N-D array Angle in degrees, specified as a real-valued or complex-valued scalar, vector, matrix, or N-D array. The <code>cosd</code> operation is element-wise when X is nonscalar. Data Types single double Complex Number Support: Yes
Output Arguments	Y - Cosine of angle scalar value vector matrix N-D array Cosine of angle, returned as a real-valued or complex-valued scalar, vector, matrix, or N-D array of the same size as X .
Examples	Cosine of 90 degrees compared to cosine of $\pi/2$ radians <code>cosd(90)</code> <code>ans =</code> 0 <code>cos(pi/2)</code> <code>ans =</code> 6.1232e-17

Cosine of complex angles specified in degrees

Create an array of three complex angles and compute the cosine.

```
z = [180+i 45+2i 10+3i];  
y = cosd(z)
```

```
y =
```

```
-1.0002          0.7075 - 0.0247i    0.9862 - 0.0091i
```

See Also

[cos](#) | [acos](#) | [acosd](#)

cosh

Purpose Hyperbolic cosine

Syntax $Y = \cosh(X)$

Description The cosh function operates element-wise on arrays. The function's domains and ranges include complex values. All angles are in radians.
 $Y = \cosh(X)$ returns the hyperbolic cosine for each element of X .

Examples **Graph of Hyperbolic Cosine**

Graph the hyperbolic cosine function over the domain $-5 \leq x \leq 5$.

```
x = -5:0.01:5;  
plot(x,cosh(x)), grid on
```

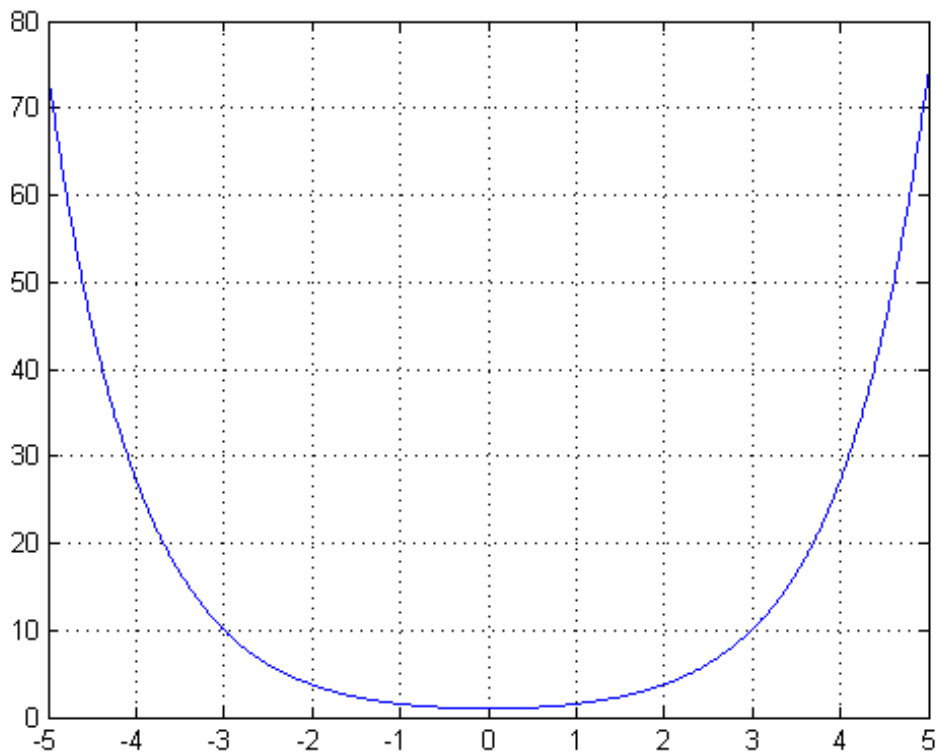
Hyperbolic Cosine

The hyperbolic cosine of z is

$$\cosh(z) = \frac{e^z + e^{-z}}{2}.$$

See Also

[acosh](#) | [cos](#) | [sinh](#) | [tanh](#)

cot

Purpose Cotangent of angle in radians

Syntax $Y = \cot(X)$

Description $Y = \cot(X)$ returns the cotangent of elements of X . The \cot function operates element-wise on arrays. The function accepts both real and complex inputs. For real values of X in the interval $[-\text{Inf}, \text{Inf}]$, \cot returns real values in the interval $[-\text{Inf}, \text{Inf}]$. For complex values of X , \cot returns complex values. All angles are in radians.

Input Arguments **X - Input angle in radians**
scalar value | vector | matrix | N-D array

Input angle in radians, specified as real-valued or complex-valued scalar, vector, matrix or N-D array. The \cot operation is element-wise when X is non-scalar.

Data Types

single | double

Complex Number Support: Yes

Output Arguments **Y - Cotangent of input angle**
scalar value | vector | matrix | N-D array

Cotangent of input angle, returned as a real-valued or complex-valued scalar, vector, matrix or N-D array.

Examples **Plot Cotangent Function**

Plot the cotangent function over the domain $-\pi < x < 0$ and $0 < x < \pi$.

```
x1 = -pi+0.01:0.01:-0.01;  
x2 = 0.01:0.01:pi-0.01;  
plot(x1,cot(x1),x2,cot(x2)), grid on
```

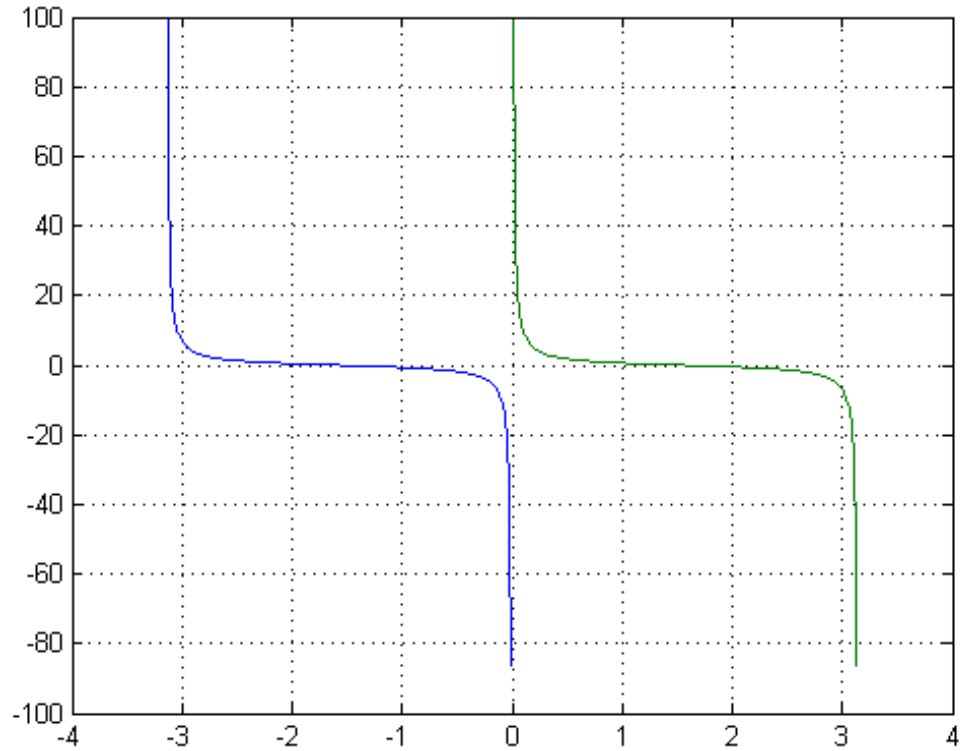

Cotangent of Vector of Complex Angles

Calculate the cotangent of the complex angles in vector x.

```
x = [-i pi+i*pi/2 -1+i*4];
y = cot(x)
```

y =

$$0.0000 + 1.3130i \quad -0.0000 - 1.0903i \quad -0.0006 - 0.9997i$$

Definitions Cotangent Function

The cotangent of an angle, α , defined with reference to a right angled triangle is

$$\text{cotangent}(\alpha) = \frac{1}{\text{tangent}(\alpha)} = \frac{\text{adjacent side}}{\text{opposite side}} = \frac{b}{a}.$$

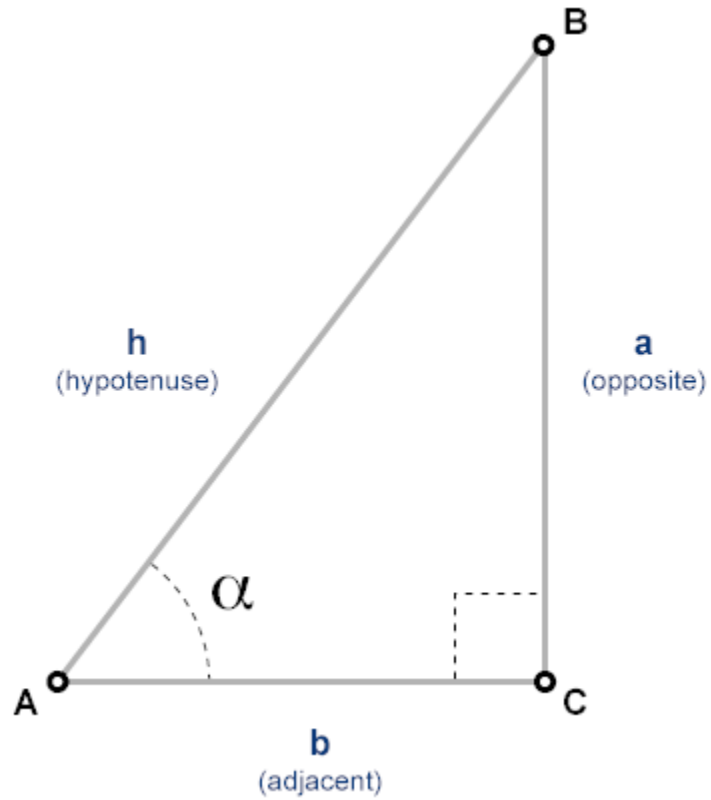

The cotangent of a complex angle α is

$$\cotangent(\alpha) = \frac{i(e^{i\alpha} + e^{-i\alpha})}{(e^{i\alpha} - e^{-i\alpha})}.$$

See Also

cotd | coth | acot | acotd | acoth

cotd

Purpose Cotangent of argument in degrees

Syntax $Y = \text{cotd}(X)$

Description $Y = \text{cotd}(X)$ returns the cotangent of the elements of X , which are expressed in degrees.

Input Arguments **X - Angle in degrees**
scalar value | vector | matrix | N-D array

Angle in degrees, specified as a real-valued or complex-valued scalar, vector, matrix, or N-D array. The `cotd` operation is element-wise when X is nonscalar.

Data Types
single | double
Complex Number Support: Yes

Output Arguments **Y - Cotangent of angle**
scalar value | vector | matrix | N-D array

Cotangent of angle, returned as a real-valued or complex-valued scalar, vector, matrix, or N-D array of the same size as X .

Examples **Cotangent of angles approaching 90 and 180 degrees**

Create a vector of input angles consisting of 90° and the next smaller and larger double precision numbers. Then compute the cotangent.

```
x1 = [90-eps(90) 90 90+eps(90)];  
y1 = cotd(x1)
```

```
y1 =
```

```
1.0e-15 *
```

```
0.2480      0      -0.2480
```

`cotd` returns zero when the input angle is exactly 90° . Evaluation at the next smaller double-precision angle returns a slightly positive result. Likewise, the cotangent is slightly negative when the input angle is the next double-precision number larger than 90° .

The behavior is similar for input angles near 180° .

```
x2 = [180-eps(180) 180 180+eps(180)];  
y2 = cotd(x2)
```

```
y2 =
```

```
1.0e+15 *  
-2.0159      Inf      2.0159
```

Cotangent of complex angle, specified in degrees

```
x = 35+5i;  
y = cotd(x)
```

```
y =
```

```
1.3958 - 0.2606i
```

See Also

`acotd` | `cot` | `acot`

coth

Purpose Hyperbolic cotangent

Syntax $Y = \text{coth}(X)$

Description The coth function operates element-wise on arrays. The function's domains and ranges include complex values. All angles are in radians. $Y = \text{coth}(X)$ returns the hyperbolic cotangent for each element of X .

Examples **Graph of Hyperbolic Cotangent**

Plot the hyperbolic cotangent over the domain $-\pi < x < 0$ and $0 < x < \pi$.

```
x1 = -pi+0.01:0.01:-0.01;  
x2 = 0.01:0.01:pi-0.01;  
plot(x1,coth(x1),x2,coth(x2)), grid on
```

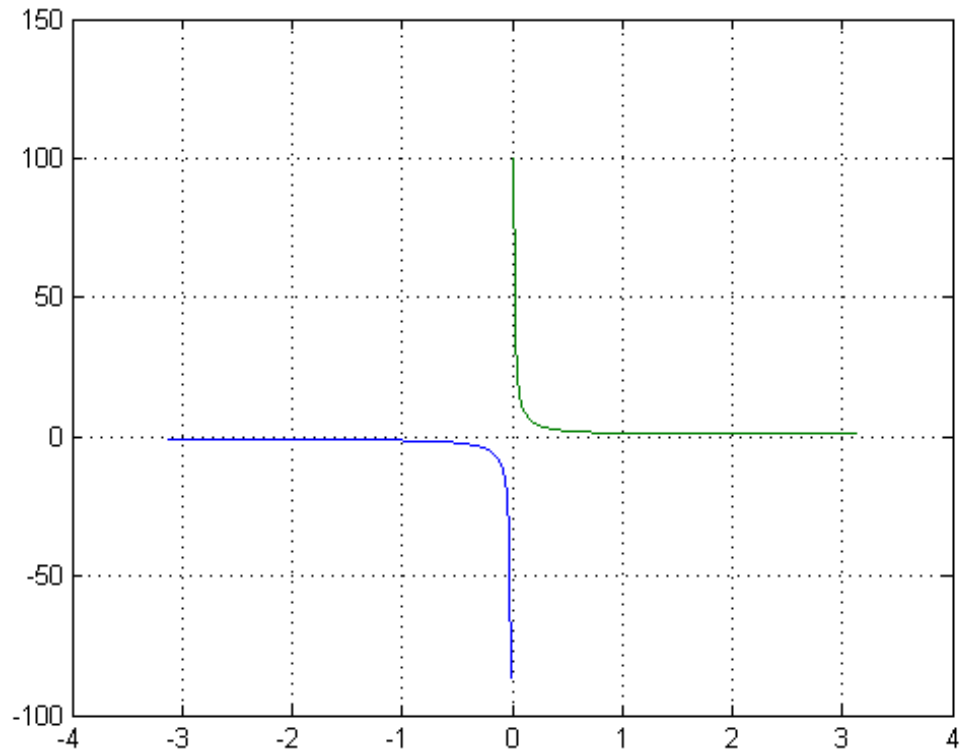
Definitions Hyperbolic Cotangent

The hyperbolic cotangent of z is

$$\coth(z) = \frac{1}{\tanh(z)}.$$

See Also `acoth` | `cot` | `sinh` | `cosh` | `tanh`

countcats

Purpose Count occurrences of categorical array elements by category

Syntax
`B = countcats(A)`
`B = countcats(A,dim)`

Description `B = countcats(A)` returns the number of elements in each category of the categorical array, A.

- If A is a vector, then `countcats` returns the number of elements in each category.
- If A is a matrix, then `countcats` treats the columns of A as vectors and returns the category counts for each column of A.
- If A is a multidimensional array, then `countcats` acts along the first array dimension whose size does not equal 1.

`B = countcats(A,dim)` returns the category counts along dimension `dim`.

For example, you can return the category counts of each row in a categorical array using `countcats(A,2)`.

Input Arguments

A - Categorical array
vector | matrix | multidimensional array

Categorical array, specified as a vector, matrix, or multidimensional array.

dim - Dimension to operate along
positive integer scalar

Dimension to operate along, specified as a positive integer scalar. If no value is specified, the default is the first array dimension whose size does not equal 1.

Consider a two-dimensional categorical array, A.

If `dim = 1`, then `countcats(A,1)` returns the category counts for each column of A.

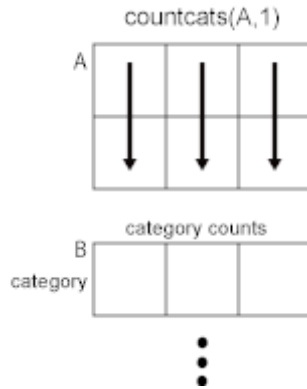

If $\text{dim} = 2$, then `countcats(A,2)` returns the category counts of each row of A.

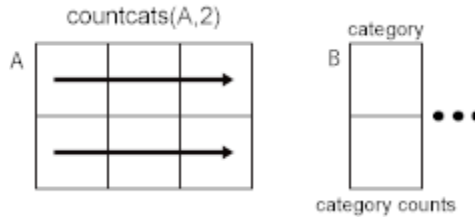

If dim is greater than $\text{ndims}(A)$, then `countcats(A)` returns an array the same size as A for each category. `countcats` returns 1 for elements in the corresponding category and 0 otherwise.

Examples

Category Counts of Categorical Vector

Create a 1-by-5 categorical vector.

```
A = categorical({'plane' 'car' 'train' 'car' 'plane'})
```

```
A =
```

```
    plane    car    train    car    plane
```

A has three categories, car, plane, and train.

countcats

Find the number of elements in each category of A.

```
B = countcats(A)
```

```
B =
```

```
     2     2     1
```

The first element in B corresponds to the first category of A, which is `car`. The second element in B corresponds to the second category of A, which is `plane`. The third element of B corresponds to the third category of A, which is `train`.

Since A is a row vector, `countcats` returns a row vector.

Category Counts of Each Column in Array

Create a 3-by-2 categorical array, A, from a numeric array.

```
valueset = 1:3;
```

```
catnames = {'red' 'green' 'blue'};
```

```
A = categorical([1 3; 2 1; 3 1],valueset,catnames)
```

```
A =
```

```
     red     blue  
     green    red  
     blue     red
```

A has three categories, `red`, `green`, and `blue`.

Find the category counts of each column in A.

```
B = countcats(A)
```

```
B =
```

```
     1     2  
     1     0
```

```

1      1

```

The first row of B corresponds to the first category of A. The value, red, occurs once in the first column of A and twice in the second column.

The second row of B corresponds to the second category of A. The value, green, occurs once in the first column of A, and it does not occur in the second column.

The third row of B corresponds to the third category of A. The value, blue, occurs once in the first column of A and once in the second column.

Category Counts of Each Row in Array

Create a 3-by-2 categorical array, A, from a numeric array.

```

valueset = 1:3;
catnames = {'red' 'green' 'blue'};

```

```

A = categorical([1 3; 2 1; 3 1],valueset,catnames)

```

```

A =

```

```

      red      blue
      green    red
      blue     red

```

A has three categories, red, green, and blue.

Find the category counts of A along the second dimension.

```

B = countcats(A,2)

```

```

B =

```

```

1      0      1
1      1      0
1      0      1

```

The first column of **B** corresponds to the first category of **A**. The value, **red**, occurs once in the first row of **A**, once in the second row, and once in the third row.

The second column of **B** corresponds to the second category of **A**. The value, **green**, occurs in only one element. It occurs in the second row of **A**.

The third column of **B** corresponds to the third category of **A**. The value, **blue**, occurs once in the first row of **A** and once in the third row.

Category Counts of Array Containing Undefined Elements

Create a 6-by-1 categorical array, **A**, from a numeric array.

```
valueset = 1:3;
catnames = {'red' 'green' 'blue'};

A = categorical([1;3;2;1;3;1],valueset,catnames)
```

```
A =

    red
    blue
    green
    red
    blue
    red
```

Remove the blue category.

```
A = removecats(A, 'blue')
```

```
A =

    red
<undefined>
    green
    red
<undefined>
```

```
red
```

A has two categories, red and green. Elements of A that were from the blue category are now undefined.

Find the number of elements in each category of A.

```
B = countcats(A)
```

```
B =
```

```
    3  
    1
```

The first element in B corresponds to the first category of A. The value, red, occurs three times in A.

The second element in B corresponds to the second category of A. The value, green, occurs once in A.

countcats does not return any information on undefined elements.

Use the summary function to view the number of undefined elements in addition to the number of elements in each category of A.

```
summary(A)
```

```
    red            3  
   green           1  
  <undefined>     2
```

Tips

- To find the number of undefined elements in a categorical array, A, you must use `summary` or `isundefined`.

See Also

`iscategory` | `ismember` | `summary` | `isundefined` | `categories`

Purpose Covariance matrix

Syntax
`C = cov(x)`
`C = cov(x,y)`
`C = cov(x,1)`
`C = cov(x,y,1)`

Description `C = cov(x)`, if `x` is a vector, returns the variance of `x`. For matrix input `X`, where each row is an observation, and each column is a variable, `cov(X)` is the covariance matrix. `diag(cov(X))` is a vector of variances for each column, and `sqrt(diag(cov(X)))` is a vector of standard deviations. `cov(X,Y)`, where `X` and `Y` are matrices with the same number of elements, is equivalent to `cov([X(:) Y(:)])`.

`C = cov(x)` or `C = cov(x,y)` normalizes by $N - 1$, if $N > 1$, where N is the number of observations. This makes `cov(X)` the best unbiased estimate of the covariance matrix if the observations are from a normal distribution. For $N = 1$, `cov` normalizes by N .

`C = cov(x,1)` or `C = cov(x,y,1)` normalizes by N and produces the second moment matrix of the observations about their mean. `cov(X,Y,0)` is the same as `cov(X,Y)` and `cov(X,0)` is the same as `cov(X)`.

Tips `cov` removes the mean from each column before calculating the result.

The *covariance* between two random variables is:

$$\text{cov}(x_1, x_2) = E[(x_1 - \mu_1)(x_2 - \mu_2)]$$

where E is the mathematical expectation and $\mu_i = E x_i$.

Examples Consider `A = [-1 1 2 ; -2 3 1 ; 4 0 3]`. To obtain a vector of variances for each column of `A`:

```
v = diag(cov(A))'  
v =  
    10.3333     2.3333     1.0000
```

Compare vector v with covariance matrix C of A :

$C = \text{cov}(A)$

$C =$

10.3333	-4.1667	3.0000
-4.1667	2.3333	-1.5000
3.0000	-1.5000	1.0000

The diagonal elements $C(i, i)$ represent the variances for the columns of A . The off-diagonal elements $C(i, j)$ represent the covariances of columns i and j .

See Also

[corrcoef](#) | [mean](#) | [median](#) | [std](#) | [var](#) | [xcorr](#) | [xcov](#)

cplxpair

Purpose Sort complex numbers into complex conjugate pairs

Syntax

```
B = cplxpair(A)
B = cplxpair(A,tol)
B = cplxpair(A,[],dim)
B = cplxpair(A,tol,dim)
```

Description `B = cplxpair(A)` sorts the elements along different dimensions of a complex array, grouping together complex conjugate pairs.

The conjugate pairs are ordered by increasing real part. Within a pair, the element with negative imaginary part comes first. The purely real values are returned following all the complex pairs. The complex conjugate pairs are forced to be exact complex conjugates. A default tolerance of $100 \cdot \text{eps}$ relative to $\text{abs}(A(i))$ determines which numbers are real and which elements are paired complex conjugates.

If `A` is a vector, `cplxpair(A)` returns `A` with complex conjugate pairs grouped together.

If `A` is a matrix, `cplxpair(A)` returns `A` with its columns sorted and complex conjugates paired.

If `A` is a multidimensional array, `cplxpair(A)` treats the values along the first non-singleton dimension as vectors, returning an array of sorted elements.

`B = cplxpair(A,tol)` overrides the default tolerance.

`B = cplxpair(A,[],dim)` sorts `A` along the dimension specified by scalar `dim`.

`B = cplxpair(A,tol,dim)` sorts `A` along the specified dimension and overrides the default tolerance.

Diagnostics If there are an odd number of complex numbers, or if the complex numbers cannot be grouped into complex conjugate pairs within the tolerance, `cplxpair` generates the error message

Complex numbers can't be paired.

Purpose	Elapsed CPU time
Syntax	<code>cputime</code>
Description	<code>cputime</code> returns the total CPU time (in seconds) used by your MATLAB application from the time it was started. This number can overflow the internal representation and wrap around.
Tips	Although it is possible to measure performance using the <code>cputime</code> function, it is recommended that you use the <code>timeit</code> or <code>tic</code> and <code>toc</code> functions for this purpose exclusively. See Using tic and toc Versus the cputime Function in the MATLAB Programming Fundamentals documentation for more information.
Examples	<p>The following code returns the CPU time used to run <code>surf(peaks(40))</code>.</p> <pre>t = cputime; surf(peaks(40)); e = cputime-t e = 0.4667</pre>
See Also	<code>clock</code> <code>etime</code> <code>tic</code> <code>timeit</code> <code>toc</code>

RandStream.create

Purpose Create random number streams

Class RandStream

Syntax

```
[s1,s2,...] = RandStream.create('gentype','NumStreams',n)
s = RandStream.create('gentype')
[ ... ] = RandStream.create('gentype', Name, Value,...)
```

Description

[s1,s2,...] = RandStream.create('gentype','NumStreams',n) creates n random number streams that use the uniform pseudorandom number generator algorithm specified by **gentype**. The streams are independent in a pseudorandom sense. The streams are not necessarily independent from streams created at other times. `RandStream.list` returns all possible values for **gentype** or see “Choosing a Random Number Generator” in the MATLAB Mathematics documentation for details on generator algorithms.

Note Multiple streams are not supported by all generator types. Use either the multiplicative lagged Fibonacci generator (`m1fg6331_64`) or the combined multiple recursive generator (`mrq32k3a`) to create multiple streams.

`s = RandStream.create('gentype')` creates a single random stream. The `RandStream` constructor is a more concise alternative when you need to create a single stream.

`[...] = RandStream.create('gentype', Name, Value,...)` allows you to specify optional Name, Value pairs to control creation of the stream. The parameters are:

NumStreams	Total number of streams of this type that will be created across sessions or labs. Default is 1.
StreamIndices	Stream indices that should be created in this call. Default is 1:N, where N is the value given with the 'NumStreams' parameter.
Seed	Nonnegative scalar integer with which to initialize all streams. Default is 0. Seeds must be an integer between 0 and $2^{32} - 1$ or 'shuffle' to create a seed based on the current time.
NormalTransform	Transformation algorithm used by <code>randn(S, ...)</code> to generate normal pseudorandom values. Options are 'Ziggurat', 'Polar', or 'Inversion'.
CellOutput	Logical flag indicating whether or not to return the stream objects as elements of a cell array. Default is false.

Typically, you call `RandStream.create` once to create multiple independent streams in a single pass. Alternatively, you can create each stream from separate calls to `RandStream.create`, but you must specify the appropriate values for `gentype`, 'NumStreams', 'Seed', and 'StreamIndices' to ensure their independence:

- Specify the same set of values for `gentype`, 'NumStreams', and 'Seed' in each case.
- Specify a different value for 'StreamIndices' that is between 1 and the 'NumStreams' value in each case.

RandStream.create

Examples

Create three independent streams.

```
[s1,s2,s3] = RandStream.create('mrg32k3a','NumStreams',3);  
r1 = rand(s1,100000,1);  
r2 = rand(s2,100000,1);  
r3 = rand(s3,100000,1);  
corrcoef([r1,r2,r3])
```

Create one stream from a set of three independent streams and designate it as the global stream.

```
s2 = RandStream.create('mrg32k3a','NumStreams',3,'StreamIndices',2);  
RandStream.setGlobalStream(s2);
```

See Also

[RandStream](#) | [RandStream.list](#)

Purpose Create MATLAB class based on WSDL document

Syntax `createClassFromWsd1(source)`

Description `createClassFromWsd1(source)` creates a MATLAB class, `servicename`, based on a service name defined in `source`. The `source` argument is a string that specifies a URL, full path, or relative path to a Web Services Description Language (WSDL) document located on a server. `createClassFromWsd1` creates a class folder, `@servicename`, in the current folder. The class folder contains a method file for each Web service operation, and the display method (`display.m`) and constructor (`servicename.m`) for the class.

Examples Get the methods from the `myWebService` WSDL document, which specifies two methods. The example does not use an actual WSDL document; therefore, you cannot run it. The example only illustrates how to use the function.

Create the class:

```
createClassFromWsd1('pathto_myWebService')
```

MATLAB creates the following in the current folder:

```
@myWebService  
@myWebService/method1.m  
@myWebService/method2.m  
@myWebService/display.m  
@myWebService/myWebService.m
```

Retrieve a student name, given the WSDL document for `TestScoreWebService`, at <http://examplestandardtests.com/scoreswebservice?WSDL>. The example does not use an actual WSDL document; therefore, you cannot run it. The example only illustrates how to use the function.

```
url = 'http://examplestandardtests.com/scoreswebservice?WSDL';
```

createClassFromWsd1

```
createClassFromWsd1(url);  
obj = TestScoreWebService;  
% Show the methods  
methods(obj)  
% Retrieve the first student name  
students = StudentNames(obj);  
students.StudentInfo(1)
```

MATLAB returns

```
StudentNameLast: 'Benjamin'  
StudentNameFirst: 'Ali'
```

Display the endpoint and WSDL document location:

```
display('TestScoreWebService')
```

MATLAB returns

```
endpoint: 'http://examplestandardtests.com/scoreswebservice'  
wsdl: 'http://examplestandardtests.com/scoreswebservice?WSDL'
```

See Also

[callSoapService](#) | [createSoapMessage](#) | [parseSoapResponse](#) | [xmlread](#)

How To

- “Access Web Services That Use WSDL Documents”
- “Specify Proxy Server Settings for Connecting to the Internet”

Purpose	Create copy of inputParser object (to be removed)
Compatibility	The createCopy method will be removed in a future release. Use copy instead.
Syntax	<code>pNew = createCopy(p)</code>
Description	<code>pNew = createCopy(p)</code> creates a copy of inputParser object <code>p</code> .
Tips	<ul style="list-style-type: none">Using <code>createCopy</code> is not the same as copying by assignment, such as <code>pNew = p</code>, which creates a new handle to the same object <code>p</code>.
Input Arguments	<p>p</p> <p>Object of class <code>inputParser</code>.</p>
Output Arguments	<p>pNew</p> <p><code>inputParser</code> object with the same properties as object <code>p</code>.</p>
Examples	<p>Copy Input Parser Scheme</p> <p>Create a copy of an existing <code>inputParser</code> object, and add an optional input to the copy.</p> <pre>p = inputParser; default = 0; addRequired(p, 'first'); addOptional(p, 'second', default); pNew = createCopy(p); addOptional(pNew, 'third', default);</pre> <p>Object <code>p</code> has two inputs in the scheme, <code>first</code> and <code>second</code>. Object <code>pNew</code> has an additional input, <code>third</code>.</p> <p>Parse each object.</p>

inputParser.createCopy

```
input1 = 1; input2 = 2; input3 = 3;

parse(p,input1);
p.Results

ans =
    first: 1
    second: 0

parse(pNew,input1,input2,input3);
pNew.Results

ans =
    first: 1
    second: 2
    third: 3
```

See Also [inputParser](#)

Purpose Create SOAP message to send to server

Syntax `message = createSoapMessage(namespace,method,values,names,types,style)`

Description `message = createSoapMessage(namespace,method,values,names,types,style)` creates a SOAP message based on the values you provide for the arguments. `message` is a Java document object model (DOM). To send message to the Web service, use it with `callSoapService`.

Argument	Description
<code>namespace</code>	Location of the Web service in the form of a valid Uniform Resource Identifier (URI).
<code>method</code>	Name of the Web service operation you want to run.
<code>values</code>	Cell array of input you need to provide for the method.
<code>names</code>	Cell array of parameters for method.
<code>types</code>	Cell array defining the XML data types for <code>values</code> . Specifying <code>style</code> is optional; when you do not include the argument, MATLAB uses unspecified.
<code>style</code>	Style for structuring the SOAP message, either ' document ' or ' rpc '. Specifying <code>style</code> is optional; when you do not include the argument, MATLAB uses rpc . Use a style supported by the service you specified in <code>namespace</code> .

Examples This example uses `createSoapMessage` in conjunction with other SOAP functions to retrieve information about books from a library database, specifically, the author's name for a given book title.

createSoapMessage

Note The example is not based on an actual endpoint; therefore, you cannot run it. The example only illustrates how to use the SOAP functions.

```
% Create the message:
message = createSoapMessage(...
    'urn:LibraryCatalog',...
    'getAuthor',...
    {'In the Fall'},...
    {'nameToLookUp'},...
    {'{http://www.w3.org/2001/XMLSchema}string'},...
    'rpc');
%
% Send the message to the service and get the response:
response = callSoapService(...
    'http://test/soap/services/LibraryCatalog',...
    'urn:LibraryCatalog#getAuthor',...
    message)
%
% Extract MATLAB data from the response
author = parseSoapResponse(response)
```

MATLAB returns:

```
author = Kate Alvin
```

where author is a char class (type).

See Also

[callSoapService](#) | [createClassFromWsd1](#) | [parseSoapResponse](#) | [urlread](#) | [xmlread](#)

How To

- “Access Web Services Using MATLAB SOAP Functions”

Purpose

Cross product

Syntax

```
C = cross(A,B)
C = cross(A,B,dim)
```

Description

`C = cross(A,B)` returns the cross product of A and B.

- If A and B are vectors, then they must have a length of 3.
- If A and B are matrices or multidimensional arrays, then they must have the same size. In this case, the `CROSS` function treats A and B as collections of three-element vectors. The function calculates the cross product of corresponding vectors along the first array dimension whose size equals 3.

`C = cross(A,B,dim)` evaluates the cross product of arrays A and B along dimension, `dim`. A and B must have the same size, and both `size(A,dim)` and `size(B,dim)` must be 3. The `dim` input is a positive integer scalar.

Input Arguments**A,B - Input arrays**

numeric arrays

Input arrays, specified as numeric arrays.

Data Types

single | double

Complex Number Support: Yes

dim - Dimension to operate along

positive integer scalar

Dimension to operate along, specified as a positive integer scalar. The size of dimension `dim` must be 3. If no value is specified, the default is the first array dimension whose size equals 3.

Consider two 2-D input arrays, A and B:

CROSS

- `cross(A,B,1)` treats the columns of A and B as vectors and returns the cross products of corresponding columns.
- `cross(A,B,2)` treats the rows of A and B as vectors and returns the cross products of corresponding rows.

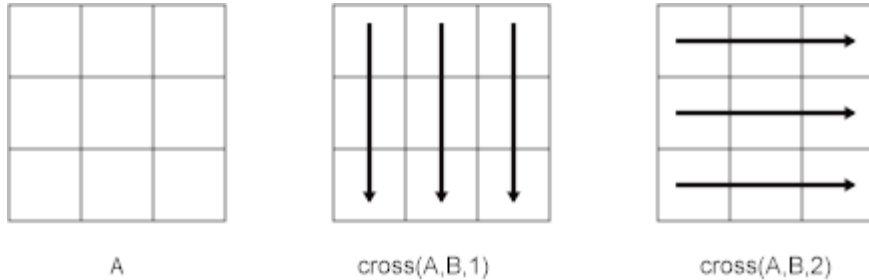

`cross` returns an error if `dim` is greater than `ndims(A)`.

Examples

Cross Product of Vectors

Create two 3-D vectors.

```
A = [4 -2 1];
```

```
B = [1 -1 3];
```

Find the cross product of A and B.

```
C = cross(A,B)
```

```
C =
```

```
-5  -11  -2
```

The result, C, is a vector that is perpendicular to both A and B.

Use dot products to verify that C is perpendicular to A and B.

```
dot(C,A)==0 & dot(C,B)==0
```

```
ans =
```

1

The result is logical 1 (true).

Cross Product of Matrices

Create two matrices containing random integers.

```
rng(0)
```

```
A = randi(15,3,5)
```

```
B = randi(25,3,5)
```

```
A =
```

```
    13    14     5    15    15
    14    10     9     3     8
     2     2    15    15    13
```

```
B =
```

```
     4    20     1    17    10
    11    24    22    19    17
    23    17    24    19     5
```

Find the cross product of A and B.

```
C = cross(A,B)
```

```
C =
```

```
    300    122   -114   -228   -181
   -291   -198   -105    -30    55
     87    136    101    234    175
```

The result, C, contains five independent cross products between the columns of A and B. For example, $C(:, 1)$ is equal to the cross product of $A(:, 1)$ with $B(:, 1)$.

Cross Product of Multidimensional Arrays

Create two 3-by-3-by-3 multidimensional arrays of random integers.

```
rng(0)
A = randi(10,3,3,3);
B = randi(25,3,3,3);
```

Find the cross product of A and B, treating the rows as vectors.

```
C = cross(A,B,2)
```

```
C(:,:,1) =
```

```
   -34    12    62
    15    72  -109
   -49     8     9
```

```
C(:,:,2) =
```

```
   198  -164  -170
    45     0   -18
   -55   190  -116
```

```
C(:,:,3) =
```

```
  -109   -45   131
     1   -74    82
    -6   101  -121
```

The result is a collection of row vectors. For example, $C(1, :, 1)$ is equal to the cross product of $A(1, :, 1)$ with $B(1, :, 1)$.

Find the cross product of A and B along the third dimension (`dim = 3`).

```
D = cross(A,B,3)
```

$$D(:, :, 1) =$$

$$\begin{array}{ccc} -14 & 179 & -106 \\ -56 & -4 & -75 \\ 2 & -37 & 10 \end{array}$$

$$D(:, :, 2) =$$

$$\begin{array}{ccc} -37 & -162 & -37 \\ 50 & -124 & -78 \\ 1 & 63 & 118 \end{array}$$

$$D(:, :, 3) =$$

$$\begin{array}{ccc} 62 & -170 & 56 \\ 46 & 72 & 105 \\ -2 & -53 & -160 \end{array}$$

The result is a collection of vectors oriented in the third dimension. For example, $C(1, 1, :)$ is equal to the cross product of $A(1, 1, :)$ with $B(1, 1, :)$.

Definitions

Cross Product

The cross product between two 3-D vectors produces a new vector that is perpendicular to both.

Consider the two vectors

$$\begin{aligned} A &= a_1 \hat{i} + a_2 \hat{j} + a_3 \hat{k}, \\ B &= b_1 \hat{i} + b_2 \hat{j} + b_3 \hat{k}. \end{aligned}$$

In terms of a matrix determinant involving the basis vectors \hat{i} , \hat{j} , and \hat{k} , the cross product of A and B is

$$C = A \times B = \begin{vmatrix} \hat{i} & \hat{j} & \hat{k} \\ a_1 & a_2 & a_3 \\ b_1 & b_2 & b_3 \end{vmatrix}$$
$$= (a_2b_3 - a_3b_2)\hat{i} + (a_3b_1 - a_1b_3)\hat{j} + (a_1b_2 - a_2b_1)\hat{k}.$$

Geometrically, $A \times B$ is perpendicular to both A and B . The magnitude of the cross product, $\|A \times B\|$, is equal to the area of the parallelogram formed using A and B as sides. This area is related to the magnitudes of A and B as well as the angle between the vectors by

$$\|A \times B\| = \|A\|\|B\|\sin \alpha.$$

Thus, if A and B are parallel, then the cross product is zero.

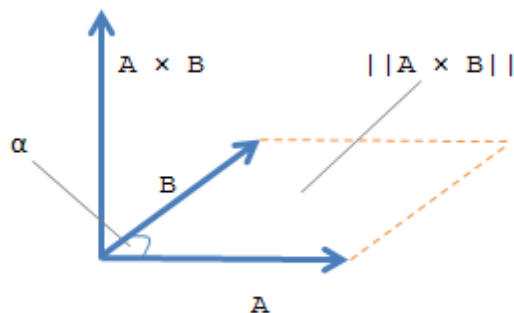

See Also

dot | kron

Purpose	Cosecant of input angle in radians
Syntax	$Y = \text{csc}(X)$
Description	$Y = \text{csc}(X)$ returns the cosecant of the elements of X . The <code>csc</code> function operates element-wise on arrays. The function accepts both real and complex inputs. For real values of X in the interval $[-\text{Inf}, \text{Inf}]$, <code>csc</code> returns real values in the interval $[-\text{Inf}, -1]$ and $[1, \text{Inf}]$. For complex values of X , <code>csc</code> returns complex values. All angles are in radians.
Input Arguments	X - Input angle in radians scalar value vector matrix N-D array Input angle in radians, specified as a real-valued or complex-valued scalar, vector, matrix or N-D array. The <code>csc</code> operation is element-wise when X is non-scalar. Data Types single double Complex Number Support: Yes
Output Arguments	Y - Cosecant of input angle scalar value vector matrix N-D array Cosecant of input angle, returned as a real-valued or complex-valued scalar, vector, matrix or N-D array.
Examples	Plot Cosecant Function Plot the cosecant function over the domain $-\pi < x < 0$ and $0 < x < \pi$ as shown. <pre>x1 = -pi+0.01:0.01:-0.01; x2 = 0.01:0.01:pi-0.01; plot(x1,csc(x1),x2,csc(x2)), grid on</pre>

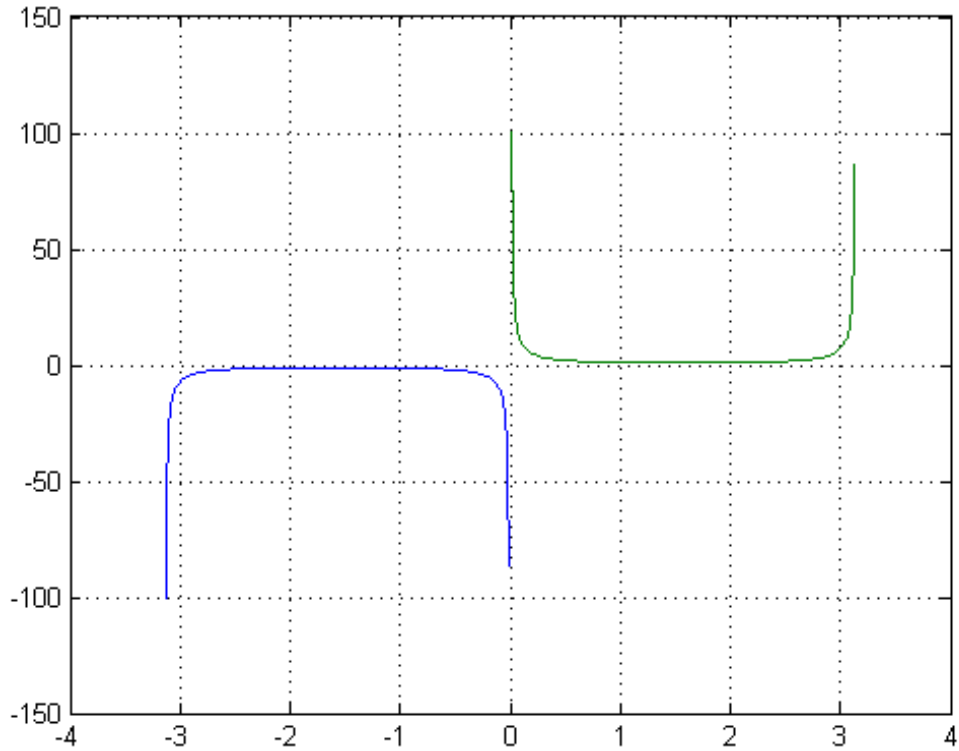

Cosecant of Vector of Complex Angles

Calculate the cosecant of the complex angles in vector x.

```
x = [-i pi+i*pi/2 -1+i*4];
y = csc(x)
```

y =

$$0.0000 + 0.8509i \quad 0.0000 + 0.4345i \quad -0.0308 - 0.0198i$$

Definitions

Cosecant Function

The cosecant of an angle, α , defined with reference to a right angled triangle is

$$\operatorname{cosecant}(\alpha) = \frac{1}{\sin(\alpha)} = \frac{\text{hypotenuse}}{\text{opposite side}} = \frac{h}{a}.$$

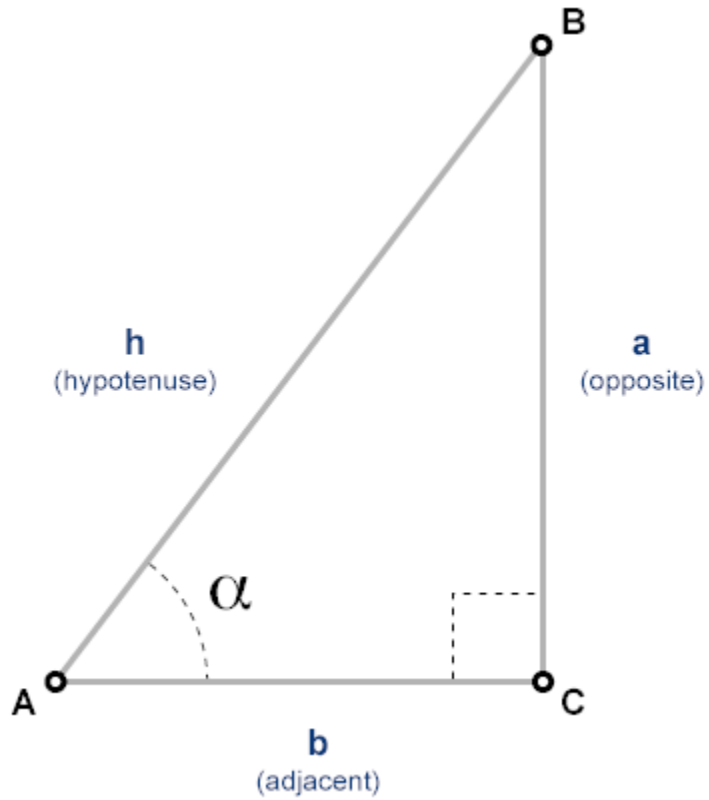

The cosecant of a complex angle, α , is

$$\operatorname{cosecant}(\alpha) = \frac{2i}{e^{i\alpha} - e^{-i\alpha}}.$$

See Also

cscd | csch | acsc | acscd | acsch

Purpose	Cosecant of argument in degrees
Syntax	$Y = \text{cscd}(X)$
Description	$Y = \text{cscd}(X)$ returns the cosecant of the elements of X , which are expressed in degrees.
Input Arguments	<p>X - Angle in degrees scalar value vector matrix N-D array</p> <p>Angle in degrees, specified as a real-valued or complex-valued scalar, vector, matrix, or N-D array. The <code>cscd</code> operation is element-wise when X is nonscalar.</p> <p>Data Types single double</p> <p>Complex Number Support: Yes</p>
Output Arguments	<p>Y - Cosecant of angle scalar value vector matrix N-D array</p> <p>Cosecant of angle, returned as a real-valued or complex-valued scalar, vector, matrix, or N-D array of the same size as X.</p>
Examples	<p>Cosecant of 180 degrees compared to cosecant of radians</p> <p><code>cscd(180)</code> is infinite, whereas <code>csc(pi)</code> is large but finite.</p> <pre>cscd(180) ans = Inf csc(pi) ans =</pre>

8.1656e+15

Cosecant of vector of complex angles, specified in degrees

$z = [35+i \ 15+2i \ 10+3i];$

$y = \text{cscd}(z)$

$y =$

1.7421 - 0.0434i 3.7970 - 0.4944i 5.2857 - 1.5681i

See Also

[acscd](#) | [csc](#) | [acsc](#)

Purpose Hyperbolic cosecant

Syntax $Y = \operatorname{csch}(x)$

Description The `csch` function operates element-wise on arrays. The function's domains and ranges include complex values. All angles are in radians. $Y = \operatorname{csch}(x)$ returns the hyperbolic cosecant for each element of x .

Examples **Graph of Hyperbolic Cosecant**

Plot the hyperbolic cosecant over the domain $-\pi < x < 0$ and $0 < x < \pi$.

```
x1 = -pi+0.01:0.01:-0.01;  
x2 = 0.01:0.01:pi-0.01;  
plot(x1,csch(x1),x2,csch(x2)), grid on
```

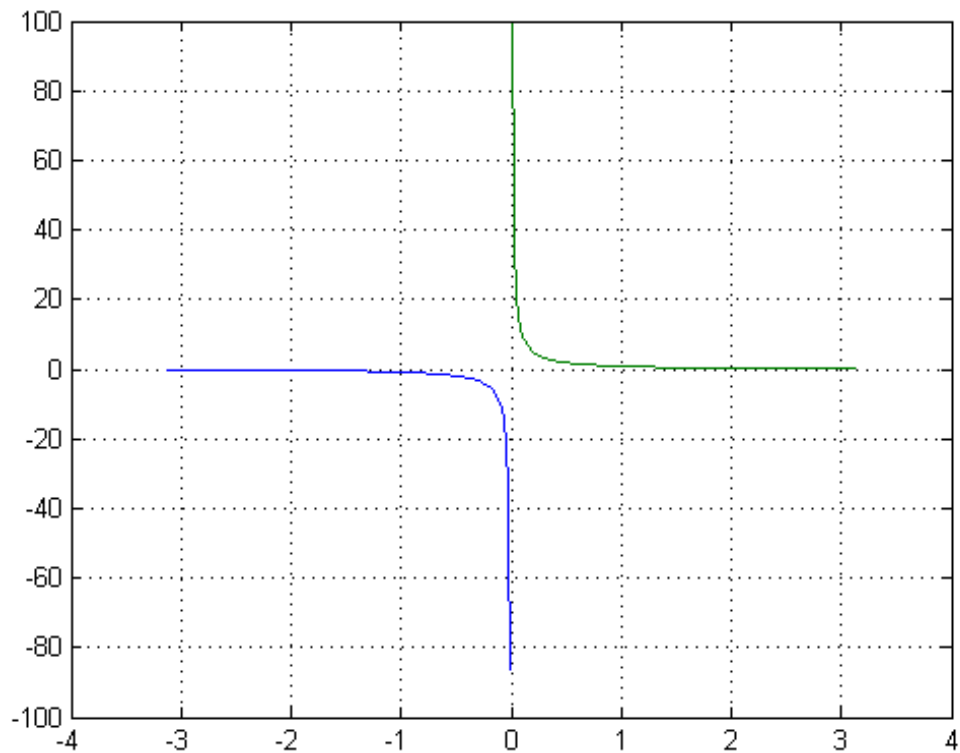

Definitions **Hyperbolic Cosecant**

The hyperbolic cosecant of z is

$$\text{csch}(z) = \frac{1}{\sinh(z)}.$$

See Also [acsch](#) | [csc](#) | [sinh](#) | [cosh](#)

Purpose Read comma-separated value file

Syntax

```
M = csvread(filename)
M = csvread(filename,row,col)
M = csvread(filename,row,col, csvRange)
```

Description M = csvread(filename) reads a comma-separated value formatted file, filename. The file can only contain numeric values.

M = csvread(filename,row,col) reads data from the file starting at the specified row and column. The row and column arguments are zero based, so that row = 0 and col = 0 specify the first value in the file.

M = csvread(filename,row,col, csvRange) reads only the range specified by csvRange.

Input Arguments

filename - Name of file to read

string

Name of the file to read, specified as a string.

Example: 'myFile.dat'

Data Types

char

row - Row of first value to read

0 (default) | positive integer

Row of the first value to read, specified as a positive integer. row is zero based, so that row = 0 specifies the first row of data.

Data Types

single | double | int8 | int16 | int32 | int64 | uint8 | uint16 | uint32 | uint64

col - Column of first value to read

0 (default) | positive integer

Column of the first value to read, specified as a positive integer. `col` is zero based, so that `col = 0` specifies the first column of data.

Data Types

`single` | `double` | `int8` | `int16` | `int32` | `int64` | `uint8` | `uint16` | `uint32` | `uint64`

csvRange - Range of data to read

4-element vector | string

Range of the data to read, specified as a 4-element vector or a string.

- If `csvRange` is a 4-element vector, then it must have the form `[R1,C1,R2,C2]`, where `(R1,C1)` is the upper left corner of the data to be read and `(R2,C2)` is the lower right corner. The range is zero based, so that `R1 = 0` specifies the first row of data, and `C1 = 0` specifies the first column of data.
- If `csvRange` is a string, then it should be specified using spreadsheet notation, as in `csvRange = 'A1..B7'`.

Data Types

`single` | `double` | `int8` | `int16` | `int32` | `int64` | `uint8` | `uint16` | `uint32` | `uint64` | `char`

Output Arguments

M - Numeric data

matrix

Numeric data, returned as a matrix of double values.

Examples

Read File Containing Comma-Separated Values

Create a file, `csvlist.dat`, that contains these comma-separated values.

```
02, 04, 06, 08
03, 06, 09, 12
05, 10, 15, 20
07, 14, 21, 28
```

Read the entire file.

```
filename = 'csvlist.dat';
M = csvread(filename)
```

M =

```

     2     4     6     8
     3     6     9    12
     5    10    15    20
     7    14    21    28
```

csvread returns the numeric data in M.

Read Data Starting at Specific Row and Column

Read data from the file, csvlist.dat, of the previous example, starting at zero-based row 2, column 0.

```
M = csvread('csvlist.dat',2,0)
```

M =

```

     5    10    15    20
     7    14    21    28
```

Read a Specific Range of Data

Read a specific range of data from the file, csvlist.dat, of the first example.

Read the matrix bounded by zero-based (1,0) and (2,2).

```
M = csvread('csvlist.dat',1,0,[1,0,2,2])
```

M =

```

     3     6     9
     5    10    15
```

csvread

Algorithms

csvread fills empty delimited fields with zero. When csvread reads data files with lines that end with a nonspace delimiter, such as a semicolon, it returns a matrix, M, that has an additional last column of zeros.

csvread imports any complex number as a whole into a complex numeric field, converting the real and imaginary parts to the specified numeric type. The table shows valid forms for a complex number.

Form	Example
-<real>-<imag>i j	5.7-3.1i
-<imag>i j	-7j

Embedded white-space in a complex number is invalid and is regarded as a field delimiter.

See Also

csvwrite | dlmread | textscan | readtable | uiimport

Purpose Complex conjugate transpose

Syntax
 $b = a'$
 $b = \text{ctranspose}(a)$

Description
 $b = a'$ computes the complex conjugate transpose of matrix a and returns the result in b .
 $b = \text{ctranspose}(a)$ is called for the syntax a' (complex conjugate transpose) when a is an object.

See Also transpose

csvwrite

Purpose Write comma-separated value file

Syntax `csvwrite(filename,M)`
`csvwrite(filename,M,row,col)`

Description `csvwrite(filename,M)` writes matrix `M` into `filename` as comma-separated values. The `filename` input is a string enclosed in single quotes.

`csvwrite(filename,M,row,col)` writes matrix `M` into `filename` starting at the specified row and column offset. The row and column arguments are zero based, so that `row=0` and `C=0` specify the first value in the file.

- Tips**
- `csvwrite` terminates each line with a line feed character and no carriage return.
 - `csvwrite` writes a maximum of five significant digits. If you need greater precision, use `dlmwrite` with a precision argument.
 - `csvwrite` does not accept cell arrays for the input matrix `M`. To export a cell array that contains only numeric data, use `cell2mat` to convert the cell array to a numeric matrix before calling `csvwrite`. To export cell arrays with mixed alphabetic and numeric data, where each cell contains a single element, you can create an Excel spreadsheet (if your system has Excel installed) using `xlswrite`. For all other cases, you must use low-level export functions to write your data. For more information, see “Export Cell Array to Text File” in the MATLAB Data Import and Export documentation.

Examples The following example creates a comma-separated value file from the matrix `m`.

```
m = [3 6 9 12 15; 5 10 15 20 25; ...  
     7 14 21 28 35; 11 22 33 44 55];  
  
csvwrite('csvlist.dat',m)  
type csvlist.dat
```



```
3,6,9,12,15  
5,10,15,20,25  
7,14,21,28,35  
11,22,33,44,55
```

The next example writes the matrix to the file, starting at a column offset of 2.

```
csvwrite('csvlist.dat',m,0,2)  
type csvlist.dat
```

```
,,3,6,9,12,15  
,,5,10,15,20,25  
,,7,14,21,28,35  
,,11,22,33,44,55
```

See Also

[csvread](#) | [dlmwrite](#) | [xlswrite](#) | [writetable](#) | [uiimport](#)

cumprod

Purpose Cumulative product

Syntax
B = cumprod(A)
B = cumprod(A,dim)

Description B = cumprod(A) returns an array the same size as the array A containing the cumulative product.

- If A is a vector, then cumprod(A) returns a vector containing the cumulative product of the elements of A.
- If A is a matrix, then cumprod(A) returns a matrix containing the cumulative products for each column of A.
- If A is a multidimensional array, then cumprod(A) acts along the first nonsingleton dimension.

B = cumprod(A,dim) returns the cumulative product along dimension dim. For example, if A is a matrix, then cumprod(A,2) returns the cumulative product of each row.

Input Arguments

A - Input array
vector | matrix | multidimensional array

Input array, specified as a vector, matrix, or multidimensional array.

Data Types
double | single | int8 | int16 | int32 | int64 | uint8 |
uint16 | uint32 | uint64 | logical

Complex Number Support: Yes

dim - Dimension to operate along

positive integer scalar

Dimension to operate along, specified as a positive integer scalar. If no value is specified, the default is the first array dimension whose size does not equal 1.

Consider a two-dimensional input array, A.

- `cumprod(A,1)` works along the rows of `A` and returns the cumulative product of each column.
- `cumprod(A,2)` works along the columns of `A` and returns the cumulative product of each row.

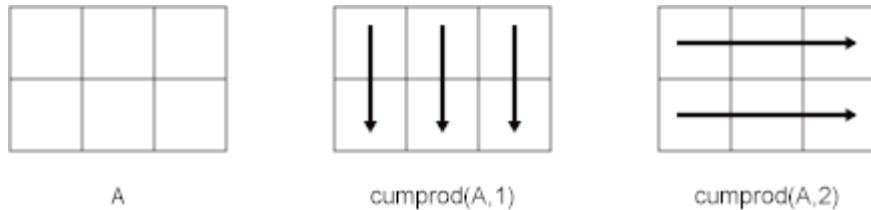

`cumprod` returns `A` if `dim` is greater than `ndims(A)`.

Data Types

`double` | `single` | `int8` | `int16` | `int32` | `int64` | `uint8` | `uint16` | `uint32` | `uint64`

Output Arguments

B - Cumulative product array

`vector` | `matrix` | `multidimensional array`

Cumulative product array, returned as a vector, matrix, or multidimensional array of the same size as the input array `A`.

The class of `B` is the same as the class of `A` except if `A` is `logical`, in which case `B` is `double`.

Definitions

First Nonsingleton Dimension

The first nonsingleton dimension is the first dimension of an array whose size is not equal to 1.

For example:

- If `X` is a 1-by-`n` row vector, then the second dimension is the first nonsingleton dimension of `X`.
- If `X` is a 1-by-0-by-`n` empty array, then the second dimension is the first nonsingleton dimension of `X`.

- If X is a 1-by-1-by-3 array, then the third dimension is the first nonsingleton dimension of X .

Examples

Cumulative Product of Vector

Find the cumulative product of the integers from 1 to 5.

```
A = [1:5];  
B = cumprod(A)
```

B =

```
     1     2     6    24   120
```

$B(2)$ is the product of $A(1)$ and $A(2)$, while $B(5)$ is the product of elements $A(1)$ through $A(5)$.

Cumulative Product of Each Column in Matrix

Define a 3-by-3 matrix whose elements correspond to their linear indices.

```
A = [1 4 7; 2 5 8; 3 6 9]
```

A =

```
     1     4     7  
     2     5     8  
     3     6     9
```

Find the cumulative product of the columns of A .

```
B = cumprod(A)
```

B =

```
     1     4     7  
     2    20    56  
     6   120   504
```

B(5) is the product of A(4) and A(5), while B(9) is the product of A(7) , A(8), and A(9).

Cumulative Product of Each Row in Matrix

Define a 2-by-3 matrix whose elements correspond to their linear indices.

```
A = [1 3 5; 2 4 6]
```

```
A =
```

```
     1     3     5
     2     4     6
```

Find the cumulative product of the rows of A.

```
B = cumprod(A,2)
```

```
B =
```

```
     1     3    15
     2     8    48
```

B(3) is the product of A(1) and A(3), while B(5) is the product of A(1), A(3), and A(5) .

Logical Input with Double Output

Create an array of logical values.

```
A = [true false true; true true false]
```

```
A =
```

```
     1     0     1
     1     1     0
```

Find the cumulative product of the rows of A.

cumprod

```
B = cumprod(A,2)
```

```
B =
```

```
    1    0    0
    1    1    0
```

The output is double.

```
class(B)
```

```
ans =
```

```
double
```

See Also

```
cumsum | prod | sum
```

Purpose	Cumulative sum
Syntax	<pre>B = cumsum(A) B = cumsum(A,dim)</pre>
Description	<p><code>B = cumsum(A)</code> returns an array of the same size as the array <code>A</code> containing the cumulative sum.</p> <ul style="list-style-type: none">• If <code>A</code> is a vector, then <code>cumsum(A)</code> returns a vector containing the cumulative sum of the elements of <code>A</code>.• If <code>A</code> is a matrix, then <code>cumsum(A)</code> returns a matrix containing the cumulative sums for each column of <code>A</code>.• If <code>A</code> is a multidimensional array, then <code>cumsum(A)</code> acts along the first nonsingleton dimension. <p><code>B = cumsum(A,dim)</code> returns the cumulative sum of the elements along dimension <code>dim</code>. For example, if <code>A</code> is a matrix, then <code>cumsum(A,2)</code> returns the cumulative sum of each row.</p>
Input Arguments	<p>A - Input array vector matrix multidimensional array</p> <p>Input array, specified as a vector, matrix, or multidimensional array.</p> <p>Data Types double single int8 int16 int32 int64 uint8 uint16 uint32 uint64 logical</p> <p>Complex Number Support: Yes</p> <p>dim - Dimension to operate along positive integer scalar</p> <p>Dimension to operate along, specified as a positive integer scalar. If no value is specified, the default is the first array dimension whose size does not equal 1.</p> <p>Consider a two-dimensional input array, <code>A</code>:</p>

cumsum

- `cumsum(A,1)` works along the rows of A and returns the cumulative sum of each column.
- `cumsum(A,2)` works along the columns of A and returns the cumulative sum of each row.

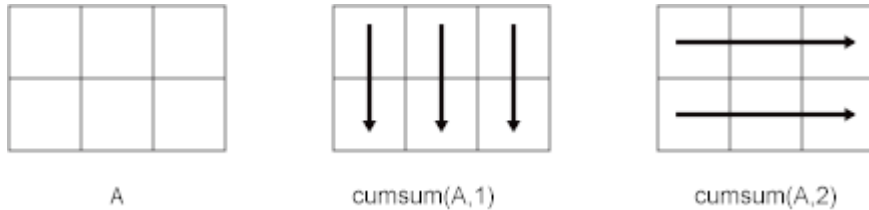

`cumsum` returns A if `dim` is greater than `ndims(A)`.

Data Types

`double` | `single` | `int8` | `int16` | `int32` | `int64` | `uint8` | `uint16` | `uint32` | `uint64`

Output Arguments

B - Cumulative sum array

`vector` | `matrix` | `multidimensional array`

Cumulative sum array, returned as a vector, matrix, or multidimensional array of the same size as the input array A.

The class of B is the same as the class of A except if A is `logical`, in which case B is `double`.

Definitions

First Nonsingleton Dimension

The first nonsingleton dimension is the first dimension of an array whose size is not equal to 1.

For example:

- If X is a 1-by-n row vector, then the second dimension is the first nonsingleton dimension of X.
- If X is a 1-by-0-by-n empty array, then the second dimension is the first nonsingleton dimension of X.

- If X is a 1-by-1-by-3 array, then the third dimension is the first nonsingleton dimension of X .

Examples

Cumulative Sum of Vector

Find the cumulative sum of the integers from 1 to 5.

```
A = [1:5];
B = cumsum(A)
```

B =

```
     1     3     6    10    15
```

$B(2)$ is the sum of $A(1)$ and $A(2)$, while $B(5)$ is the sum of elements $A(1)$ through $A(5)$.

Cumulative Sum of Each Column in Matrix

Define a 3-by-3 matrix whose elements correspond to their linear indices.

```
A = [1 4 7; 2 5 8; 3 6 9]
```

A =

```
     1     4     7
     2     5     8
     3     6     9
```

Find the cumulative sum of the columns of A .

```
B = cumsum(A)
```

B =

```
     1     4     7
     3     9    15
     6    15    24
```

B(5) is the sum of A(4) and A(5), while B(9) is the sum of A(7) , A(8), and A(9).

Cumulative Sum of Each Row in Matrix

Define a 2-by-3 matrix whose elements correspond to their linear indices.

```
A = [1 3 5; 2 4 6]
```

A =

```
     1     3     5
     2     4     6
```

Find the cumulative sum of the rows of A.

```
B = cumsum(A,2)
```

B =

```
     1     4     9
     2     6    12
```

B(3) is the sum of A(1) and A(3), while B(5) is the sum of A(1), A(3), and A(5) .

Logical Input with Double Output

Create an array of logical values.

```
A = [true false true; true true false]
```

A =

```
     1     0     1
     1     1     0
```

Find the cumulative sum of the rows of A.

```
B = cumsum(A,2)
```

```
B =
```

```
    1    1    2
    1    2    2
```

The output is double.

```
class(B)
```

```
ans =
```

```
double
```

See Also

```
cumprod | prod | sum | diff
```

cumtrapz

Purpose Cumulative trapezoidal numerical integration

Syntax
`Z = cumtrapz(Y)`
`Z = cumtrapz(X,Y)`
`Z = cumtrapz(___,dim)`

Description `Z = cumtrapz(Y)` computes an approximation of the cumulative integral of `Y` via the trapezoidal method with unit spacing. To compute the integral with other than unit spacing, multiply `Z` by the spacing increment. Input `Y` can be complex.

For vectors, `cumtrapz(Y)` is a vector containing the cumulative integral of `Y`.

For matrices, `cumtrapz(Y)` is a matrix the same size as `Y` with the cumulative integral over each column.

For multidimensional arrays, `cumtrapz(Y)` works across the first nonsingleton dimension.

`Z = cumtrapz(X,Y)` computes the cumulative integral of `Y` with respect to `X` using trapezoidal integration. `X` and `Y` must be vectors of the same length, or `X` must be a column vector and `Y` an array whose first nonsingleton dimension is `length(X)`. `cumtrapz` operates across this dimension. Inputs `X` and `Y` can be complex.

If `X` is a column vector and `Y` an array whose first nonsingleton dimension is `length(X)`, `cumtrapz(X,Y)` operates across this dimension.

`Z = cumtrapz(___,dim)` integrates across the dimension of `Y` specified by scalar `dim`, using any of the input arguments in the previous syntaxes. The length of `X` must be the same as `size(Y,dim)`.

Examples

Example 1

```
Y = [0 1 2; 3 4 5];
```

```
cumtrapz(Y,1)  
ans =  
0      0      0
```

```
        1.5000    2.5000    3.5000
cumtrapz(Y,2)
ans =
0      0.5000    2.0000
      0      3.5000    8.0000
```

Example 2

This example uses two complex inputs:

```
z = exp(1i*pi*(0:100)/100);

ct = cumtrapz(z,1./z);
ct(end)
ans =
    0.0000 + 3.1411i
```

See Also

[cumsum](#) | [trapz](#)

curl

Purpose Compute curl and angular velocity of vector field

Syntax

```
[curlx,curly,curlz,cav] = curl(X,Y,Z,U,V,W)
[curlx,curly,curlz,cav] = curl(U,V,W)
[curlz,cav]= curl(X,Y,U,V)
[curlz,cav]= curl(U,V)
[curlx,curly,curlz] = curl(...), [curlx,curly] = curl(...)
cav = curl(...)
```

Description [curlx,curly,curlz,cav] = curl(X,Y,Z,U,V,W) computes the curl (curlx, curly, curlz) and angular velocity (cav) perpendicular to the flow (in radians per time unit) of a 3-D vector field U, V, W.

The arrays X, Y, and Z, which define the coordinates for U, V, and W, must be monotonic, but do not need to be uniformly spaced. X, Y, and Z must have the same number of elements, as if produced by `meshgrid`.

[curlx,curly,curlz,cav] = curl(U,V,W) assumes X, Y, and Z are determined by the expression

```
[X Y Z] = meshgrid(1:n,1:m,1:p)
```

where [m,n,p] = size(U).

[curlz,cav]= curl(X,Y,U,V) computes the curl z-component and the angular velocity perpendicular to z (in radians per time unit) of a 2-D vector field U, and V.

The arrays X and Y, which define the coordinates for U and V, must be monotonic, but do not need to be uniformly spaced. X and Y must have the same number of elements, as if produced by `meshgrid`.

[curlz,cav]= curl(U,V) assumes X and Y are determined by the expression

```
[X Y] = meshgrid(1:n,1:m)
```

where [m,n] = size(U).

```
[curlx,curly,curlz] = curl(...), [curlx,curly] = curl(...)  
returns only the curl.
```

```
cav = curl(...) returns only the curl angular velocity.
```

Examples

This example uses colored slice planes to display the curl angular velocity at specified locations in the vector field.

```
figure  
load wind  
cav = curl(x,y,z,u,v,w);  
h = slice(x,y,z,cav,[90 134],59,0);  
shading interp  
daspect([1 1 1]);  
axis tight  
colormap hot(16)  
camlight  
set([h(1),h(2)], 'ambientstrength', .6)
```

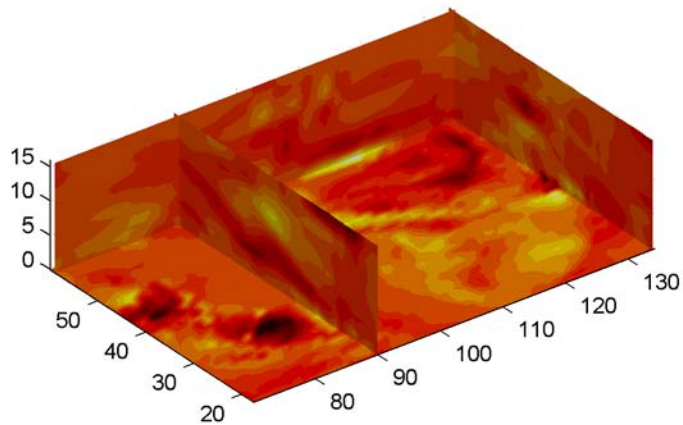

curl

This example views the curl angular velocity in one plane of the volume and plots the velocity vectors (quiver) in the same plane.

```
load wind
k = 4;
x = x(:,:,k); y = y(:,:,k); u = u(:,:,k); v = v(:,:,k);
cav = curl(x,y,u,v);
pcolor(x,y,cav); shading interp
hold on;
quiver(x,y,u,v,'y')
hold off
colormap copper
```

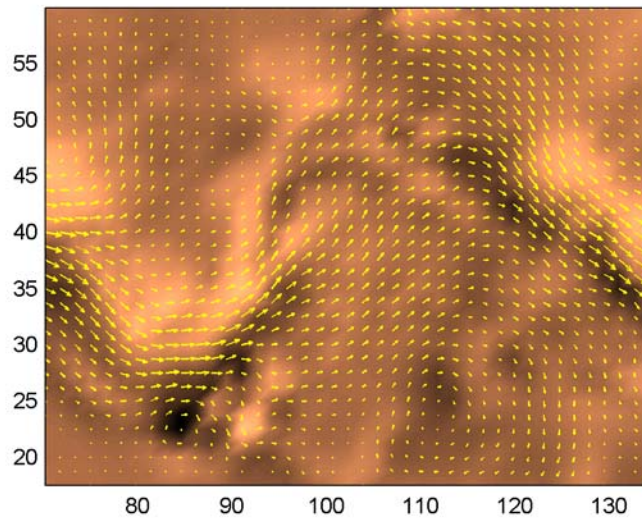

See Also

[streamribbon](#) | [divergence](#)

How To

- “Displaying Curl with Stream Ribbons”

Purpose Index of current IFD

Syntax `dirNum = tiffobj.currentDirectory()`

Description `dirNum = tiffobj.currentDirectory()` returns the index of the current image file directory (IFD). Index values are one-based. Use this index value with the `setDirectory` member function.

Examples **Determine Current IFD**

Open a Tiff object and determine which IFD is the current IFD.

```
t = Tiff('example.tif', 'r');  
dnum = t.currentDirectory()
```

```
dnum =
```

```
1
```

Close the Tiff object.

```
t.close();
```

References This method corresponds to the `TIFFCurrentDirectory` function in the LibTIFF C API. To use this method, you must be familiar with the TIFF specification and technical notes. View this documentation at [LibTiff - TIFF Library and Utilities](#).

See Also `Tiff.setDirectory`

Tutorials

- “Exporting Image Data and Metadata to TIFF Files”
- “Reading Image Data and Metadata from TIFF Files”

customverctrl

Purpose Allow custom source control system (UNIX platforms)

Syntax `customverctrl`

Description `customverctrl` function is for customers who want to integrate a source control system that is not supported for use with MATLAB software. When using this function, conform to the structure of one of the supported version control systems, for example, RCS. For examples, see the files `clearcase.m`, `cvs.m`, `pvcs.m`, and `rsc.m` in `matlabroot\toolbox\matlab\verctrl`.

See Also `checkin` | `checkout` | `cmopts` | `undocheckout` | `verctrl`

Purpose

Generate cylinder

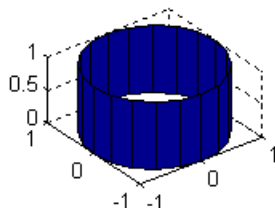
**Syntax**

```
[X,Y,Z] = cylinder
[X,Y,Z] = cylinder(r)
[X,Y,Z] = cylinder(r,n)
cylinder(axes_handle,...)
cylinder(...)
```

Description

`cylinder` generates x -, y -, and z -coordinates of a unit cylinder. You can draw the cylindrical object using `surf` or `mesh`, or draw it immediately by not providing output arguments.

`[X,Y,Z] = cylinder` returns the x -, y -, and z -coordinates of a cylinder with a radius equal to 1. The cylinder has 20 equally spaced points around its circumference.

`[X,Y,Z] = cylinder(r)` returns the x -, y -, and z -coordinates of a cylinder using r to define a profile curve. `cylinder` treats each element in r as a radius at equally spaced heights along the unit height of the cylinder. The cylinder has 20 equally spaced points around its circumference.

`[X,Y,Z] = cylinder(r,n)` returns the x -, y -, and z -coordinates of a cylinder based on the profile curve defined by vector r . The cylinder has n equally spaced points around its circumference.

`cylinder(axes_handle,...)` plots into the axes with handle `axes_handle` instead of the current axes (`gca`).

`cylinder(...)`, with no output arguments, plots the cylinder using `surf`.

cylinder

Tips

`cylinder` treats its first argument as a profile curve. The resulting surface graphics object is generated by rotating the curve about the x -axis, and then aligning it with the z -axis.

Examples

Create a cylinder with randomly colored faces.

```
cylinder  
axis square  
h = findobj('Type','surface');  
set(h,'CData',rand(size(get(h,'CData'))))
```

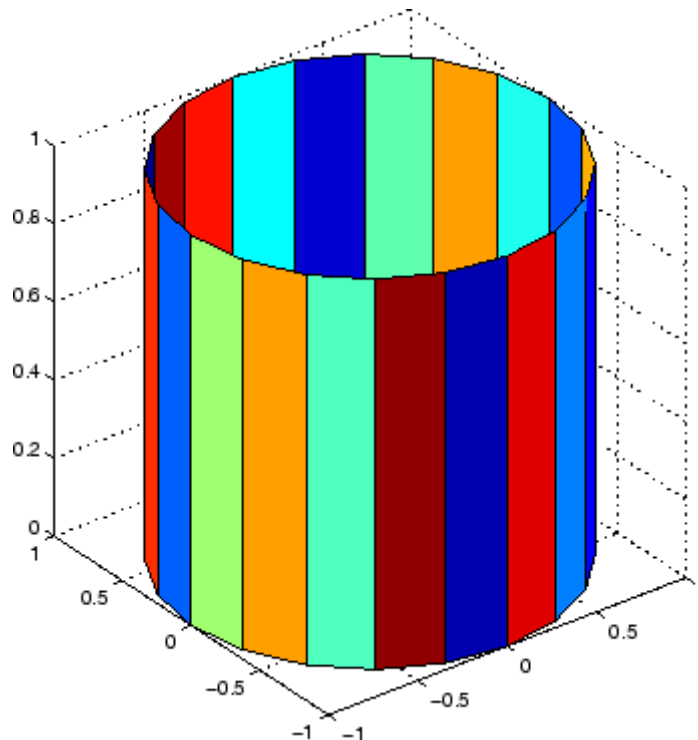

Generate a cylinder defined by the profile function $2+\sin(t)$.

```
t = 0:pi/10:2*pi;
```

```
[X,Y,Z] = cylinder(2+cos(t));  
surf(X,Y,Z)  
axis square
```

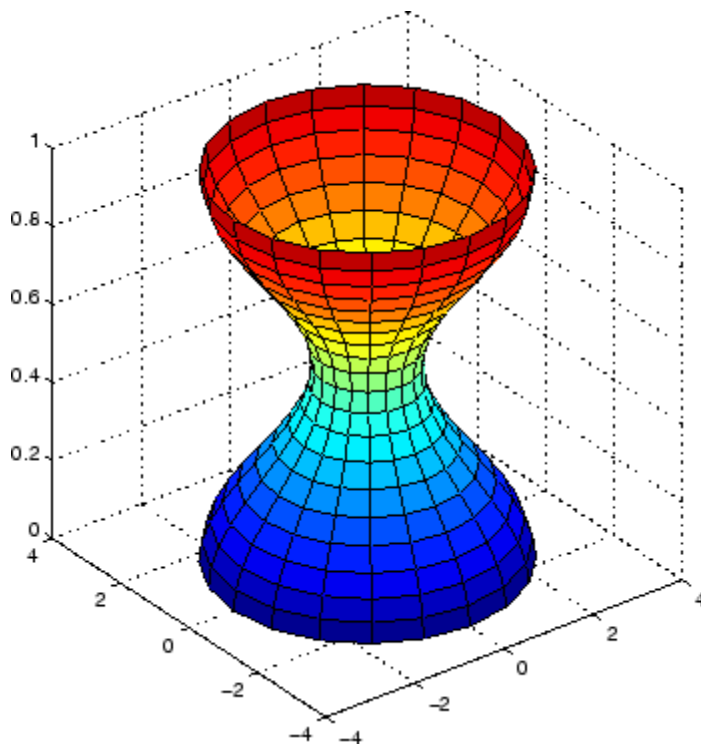

See Also

[sphere](#) | [surf](#)

daqread

Purpose Read Data Acquisition Toolbox (.daq) file

Syntax

```
data = daqread('filename')
[data, time] = daqread(...)
[data, time, abstime] = daqread(...)
[data, time, abstime, events] = daqread(...)
[data, time, abstime, events, daqinfo] = daqread(...)
data = daqread(..., 'Param1', Val1, ...)
daqinfo = daqread('filename', 'info')
```

Description `data = daqread('filename')` reads all the data from the Data Acquisition Toolbox™ (.daq) file specified by `filename`. `daqread` returns `data`, an m -by- n data matrix, where m is the number of samples and n is the number of channels. If `data` includes data from multiple triggers, the data from each trigger is separated by a NaN. If you set the `OutputFormat` property to `tscollection`, `daqread` returns a time series collection object. See below for more information.

`[data, time] = daqread(...)` returns `time/value` pairs. `time` is an m -by-1 vector, the same length as `data`, that contains the relative time for each sample. Relative time is measured with respect to the first trigger that occurs.

`[data, time, abstime] = daqread(...)` returns the absolute time of the first trigger. `abstime` is returned as a clock vector.

`[data, time, abstime, events] = daqread(...)` returns a log of events. `events` is a structure containing event information. If you specify either the `Samples`, `Time`, or `Triggers` parameters (see below), the events structure contains only the specified events.

`[data, time, abstime, events, daqinfo] = daqread(...)` returns a structure, `daqinfo`, that contains two fields: `ObjInfo` and `HwInfo`. `ObjInfo` is a structure containing property name/property value pairs and `HwInfo` is a structure containing hardware information. The entire event log is returned to `daqinfo.ObjInfo.EventLog`.

`data = daqread(..., 'Param1', Val1, ...)` specifies the amount of data returned and the format of the data, using the following parameters.

Parameter	Description
Samples	Specify the sample range.
Time	Specify the relative time range.
Triggers	Specify the trigger range.
Channels	Specify the channel range. Channel names can be specified as a cell array.
DataFormat	Specify the data format as doubles (default) or native.
TimeFormat	Specify the time format as vector (default) or matrix.
OutputFormat	Specify the output format as matrix (the default) or <code>tscollection</code> . When you specify <code>tscollection</code> , <code>daqread</code> only returns data.

The `Samples`, `Time`, and `Triggers` properties are mutually exclusive; that is, either `Samples`, `Triggers` or `Time` can be defined at once.

`daqinfo = daqread('filename', 'info')` returns metadata from the file in the `daqinfo` structure, without incurring the overhead of reading the data from the file as well. The `daqinfo` structure contains two fields:

`daqinfo.ObjInfo`

a structure containing parameter/value pairs for the data acquisition object used to create the file, `filename`. Note: The `UserData` property value is not restored.

`daqinfo.HwInfo`

a structure containing hardware information. The entire event log is returned to `daqinfo.ObjInfo.EventLog`.

Tips

More About .daq Files

- The format used by `daqread` to return data, relative time, absolute time, and event information is identical to the format used by the `getdata` function that is part of Data Acquisition Toolbox. For more information, see the Data Acquisition Toolbox documentation.
- If data from multiple triggers is read, then the size of the resulting data array is increased by the number of triggers issued because each trigger is separated by a NaN.
- `ObjInfo.EventLog` always contains the entire event log regardless of the value specified by `Samples`, `Time`, or `Triggers`.
- The `UserData` property value is not restored when you return device object (`ObjInfo`) information.
- When reading a `.daq` file, the `daqread` function does not return property values that were specified as a cell array.
- Data Acquisition Toolbox (`.daq`) files are created by specifying a value for the `LogFileName` property (or accepting the default value), and configuring the `LoggingMode` property to `Disk` or `Disk&Memory`.

More About Time Series Collection Object Returned

When `OutputFormat` is set to `tscollection`, `daqread` returns a time series collection object. This times series collection object contains an absolute time series object for each channel in the file. The following describes how `daqread` sets some of the properties of the times series collection object and the time series objects.

- The `time` property of the time series collection object is set to the value of the `InitialTriggerTime` property specified in the file.
- The `name` property of each time series object is set to the value of the `Name` property of a channel in the file. If this name cannot be used as a time series object name, `daqread` sets the name to `'Channel'` with the `HwChannel` property of the channel appended.
- The value of the `Units` property of the time series object depends on the value of the `DataFormat` parameter. If the `DataFormat` parameter

is set to 'double', `daqread` sets the `DataInfo` property of each time series object in the collection to the value of the `Units` property of the corresponding channel in the file. If the `DataFormat` parameter is set to 'native', `daqread` sets the `Units` property to 'native'. See the Data Acquisition Toolbox documentation for more information on these properties.

- Each time series object will have `tsdata.event` objects attached corresponding to the log of events associated with the channel.

If `daqread` returns data from multiple triggers, the data from each trigger is separated by a NaN in the time series data. This increases the length of data and time vectors in the time series object by the number of triggers.

Examples

Use Data Acquisition Toolbox to acquire data. The analog input object, `ai`, acquires one second of data for four channels, and saves the data to the output file `data.daq`.

```
ai = analoginput('nidaq','Dev1');
chans = addchannel(ai,0:3);
set(ai,'SampleRate',1000)
ActualRate = get(ai,'SampleRate');
set(ai,'SamplesPerTrigger', ActualRate)
set(ai,'LoggingMode','Disk&Memory')
set(ai,'LogFileName','data.daq')
start(ai)
```

After the data has been collected and saved to a disk file, you can retrieve the data and other acquisition-related information using `daqread`. To read all the sample-time pairs from `data.daq`:

```
[data,time] = daqread('data.daq');
```

To read samples 500 to 1000 for all channels from `data.daq`:

```
data = daqread('data.daq','Samples',[500 1000]);
```

daqread

To read only samples 1000 to 2000 of channel indices 2, 4 and 7 in native format from the file, `data.daq`:

```
data = daqread('data.daq', 'Samples', [1000 2000],...  
              'Channels', [2 4 7], 'DataFormat', 'native');
```

To read only the data which represents the first and second triggers on all channels from the file, `data.daq`:

```
[data, time] = daqread('data.daq', 'Triggers', [1 2]);
```

To obtain the channel property information from `data.daq`:

```
daqinfo = daqread('data.daq', 'info');  
chaninfo = daqinfo.ObjInfo.Channel;
```

To obtain a list of event types and event data contained by `data.daq`:

```
daqinfo = daqread('data.daq', 'info');  
events = daqinfo.ObjInfo.EventLog;  
event_type = {events.Type};  
event_data = {events.Data};
```

To read all the data from the file `data.daq` and return it as a time series collection object:

```
data = daqread('data.daq', 'OutputFormat', 'tscollection');
```

See Also

[timeseries](#) | [tscollection](#)

Purpose	Set or query axes data aspect ratio
Syntax	<pre>daspect daspect([aspect_ratio]) daspect('mode') daspect('auto') daspect('manual') daspect(axes_handle,...)</pre>
Description	<p>The data aspect ratio determines the relative scaling of the data units along the x-, y-, and z-axes.</p> <p><code>daspect</code> with no arguments returns the data aspect ratio of the current axes.</p> <p><code>daspect([aspect_ratio])</code> sets the data aspect ratio in the current axes to the specified value. Specify the aspect ratio as three relative values representing the ratio of the x-, y-, and z-axis scaling (e.g., <code>[1 1 3]</code> means one unit in x is equal in length to one unit in y and three units in z).</p> <p><code>daspect('mode')</code> returns the current value of the data aspect ratio mode, which can be either <code>auto</code> (the default) or <code>manual</code>. See Tips.</p> <p><code>daspect('auto')</code> sets the data aspect ratio mode to <code>auto</code>.</p> <p><code>daspect('manual')</code> sets the data aspect ratio mode to <code>manual</code>.</p> <p><code>daspect(axes_handle,...)</code> performs the set or query on the axes identified by the first argument, <code>axes_handle</code>. When you do not specify an axes handle, <code>daspect</code> operates on the current axes.</p>
Tips	<p><code>daspect</code> sets or queries values of the axes object <code>DataAspectRatio</code> and <code>DataAspectRatioMode</code> properties.</p> <p>When the data aspect ratio mode is <code>auto</code>, the data aspect ratio adjusts so that each axis spans the space available in the figure window. If you are displaying a representation of a real-life object, you should set the data aspect ratio to <code>[1 1 1]</code> to produce the correct proportions.</p>

Setting a value for data aspect ratio or setting the data aspect ratio mode to manual disables the MATLAB stretch-to-fill feature (stretching of the axes to fit the window). This means setting the data aspect ratio to a value, including its current value,

```
daspect(daspect)
```

can cause a change in the way the graphs look. See the Stretch-to-Fill section of the axes description for more information.

Examples

Equal Scaling Along Each Axis

Plot the function $z = xe^{(-x^2-y^2)}$ over the range $-2 \leq x \leq 2$ and $-2 \leq y \leq 2$.

```
[x,y] = meshgrid(-2:.2:2);  
z = x.*exp(-x.^2 - y.^2);
```

```
figure  
surf(x,y,z)
```

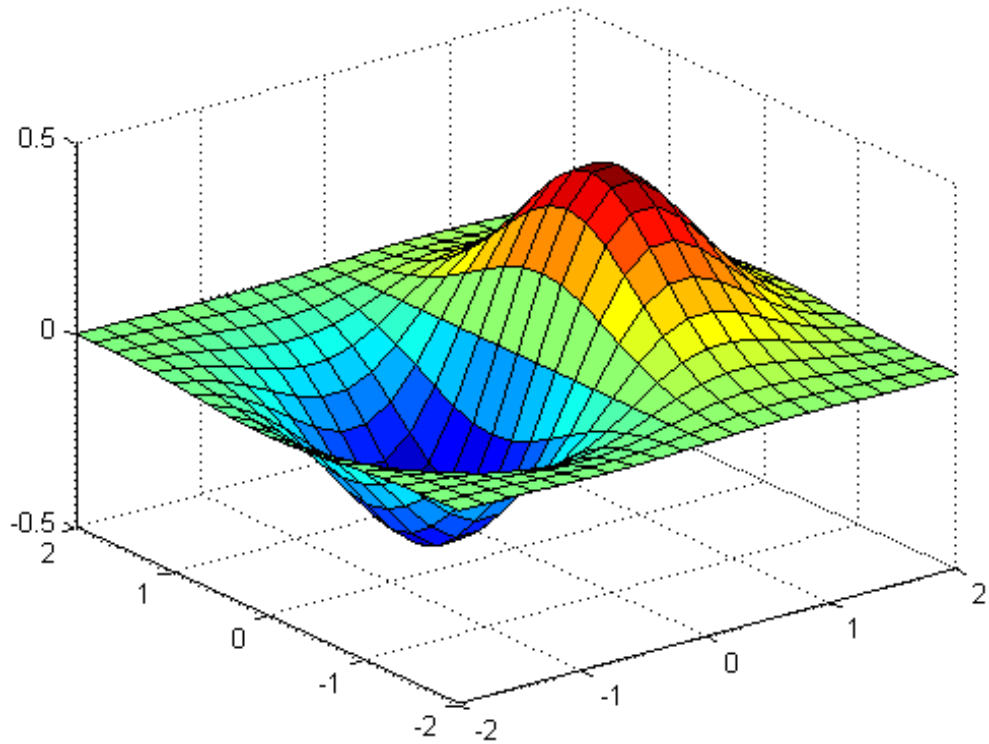

Query the data aspect ratio to show the axis scaling.

```
daspect
```

```
ans =
```

```
    4    4    1
```

daspect

Use equal scaling along each axis by setting the data aspect ratio to `[1,1,1]`.

```
daspect([1,1,1])
```

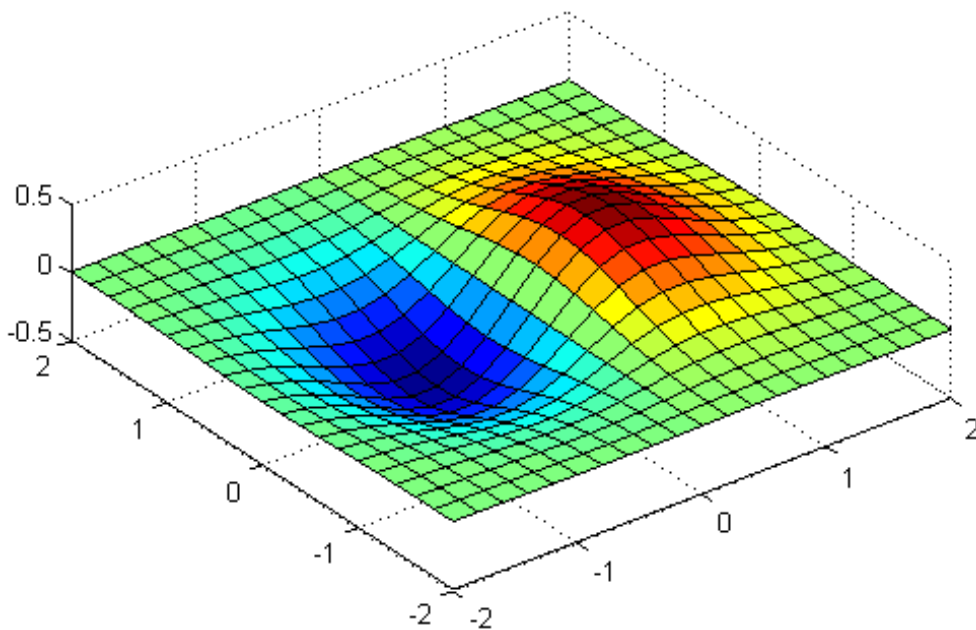

See Also

[axis](#) | [pbaspect](#) | [xlim](#) | [ylim](#) | [zlim](#)

How To

- [DataAspectRatio](#)

- `PlotBoxAspectRatio`
- `XLim`
- `YLim`
- `ZLim`
- “Understanding Axes Aspect Ratio”

datacursormode

Purpose Enable, disable, and manage interactive data cursor mode

Syntax

```
datacursormode on
datacursormode off
datacursormode
datacursormode toggle
datacursormode(figure_handle)
dcm_obj = datacursormode(figure_handle)
```

Description

`datacursormode on` enables data cursor mode on the current figure.

`datacursormode off` disables data cursor mode on the current figure.

`datacursormode` or `datacursormode toggle` toggles data cursor mode in the current figure.

`datacursormode(figure_handle)` enables or disables data cursor mode on the specified figure.

`dcm_obj = datacursormode(figure_handle)` returns the data cursor mode object for the figure. The object enables you to customize the data cursor. For more information on data cursor mode objects, see “Output Arguments” on page 1-1511. You cannot change the state of data cursor mode in a call to `datacursormode` that returns a mode object.

A *data cursor* is a small black square with a white border that you interactively position on a graph in data cursor mode. When you click a graphic object such as a line on a graph, a *data tip* appears. Data tips are small text boxes or windows that float within an axes that display data values at data cursor locations. The default style is a text box. Data tips list *x*-, *y*- and (where appropriate) *z*-values for one data point at a time. See “Examples” on page 1-1515 for an illustration of these two styles.

- Tips**
- Most types of graphs and 3-D plots support data cursor mode, but several do not (pareto, for example).
 - Polar plots support data tips, but display Cartesian rather than polar coordinates on them.

- Histograms created with `hist display` specialized data tips that itemize the observation counts, lower and upper limits and center point for histogram bins.
- You place data tips only by clicking data objects on graphs. You cannot place them programmatically (by executing code to position a data cursor).
- When `DisplayStyle` is `datatip`, you can place multiple data tips on a graph. When `DisplayStyle` is `window`, it reports only the most recent data tip.
- `datacursormode off` exits data cursor mode but does not remove displayed data tips. However, if the `DisplayStyle` is `window`, the data tip window goes away.

Input Arguments

figure_handle

Optional handle of figure window

Default: The current figure

state

`'`, `'toggle'`, `'on'`, or `'off'`

Default: `'toggle'`

Output Arguments

dcm_obj

Use the object returned by `datacursormode` to control aspects of data cursor behavior. You can use the `set` and `get` commands to set and query object property values. You can customize how data cursor mode presents information by coding callback functions for these objects.

Parameter Name/Value Pairs for Data Cursor Mode Objects

The following parameters apply to objects returned by calls to `datacursormode`, not to the function itself.

'DisplayStyle'

datatip | window

Determines how the data cursor displays.

- `datatip` displays data cursor information in a small yellow text box attached to a black square marker at a data point you interactively select.
- `window` displays data cursor information for the data point you interactively select in a floating window within the figure.

Default: `datatip`

'Enable'

on | off

Specifies whether data cursor mode is currently enabled for the figure.

Default: `off`

'Figure'

handle

Handle of the figure associated with the data cursor mode object.

'SnapToDataVertex'

on | off

Specifies whether the data cursor snaps to the nearest data value or is located at the actual pointer position.

Default: `on`

'UpdateFcn'

function handle

Reference to a function that formats the text appearing in the data cursor. You can supply your own function to customize data tip display. Your function must include at least two arguments. The first argument is unused, and can be a variable name or tilde (~). The second argument passes the data cursor event object to your update function. The event object encapsulates the state of the data cursor. The following function definition illustrates the update function:

```
function output_txt = myfunction(~,event_obj)
% ~           Currently not used (empty)
% event_obj  Object containing event data structure
% output_txt Data cursor text (string or cell array
%            of strings)
```

event_obj is an object that has the following properties.

Target	Handle of the object the data cursor is referencing (the object which you click, for example, a line or a bar from a series)
Position	An array specifying the x, y (and z for 3-D graphs) coordinates of the cursor

You can query these properties within your function. For example,

```
pos = get(event_obj, 'Position');
```

returns the coordinates of the cursor. Another way of accessing that data is to obtain the struct and query its Position field:

```
eventdata = get(event_obj);
pos = eventdata.Position;
```

You can also obtain the position directly from the object:

```
pos = event_obj.Position;
```

You can redefine the data cursor UpdateFcn at run time. For example:

```
set(dcm_obj, 'UpdateFcn', @myupdatefcn)
```

applies the function `myupdatefcn` to the current data tip or tips. When you set an update function in this way, the function must be on the MATLAB path. If instead you select the data cursor mode context menu item **Select text update function**, you can interactively select a function that is not on the path.

Do not redefine figure window callbacks, such as `ButtonDownFcn`, `KeyPressFcn`, or `CloseRequestFcn` while in data cursor mode. If you attempt to change any *figure* callbacks when you are in an interactive mode, you receive a warning and the attempt fails. MATLAB interactive modes are:

- brush
- datacursormode
- pan
- rotate3d
- zoom

This restriction does not apply to changing the figure `WindowButtonMotionFcn` callback or `uicontrol` callbacks.

Querying Data Cursor Mode

Use the `getCursorInfo` function to query the data cursor mode object (`dcm_obj` in the update function syntax) to obtain information about the data cursor. For example,

```
info_struct = getCursorInfo(dcm_obj);
```

returns a vector of structures, one for each data cursor on the graph. Each structure has the following fields.

Target	The handle of the graphics object containing the data point
Position	An array specifying the x , y , (and z) coordinates of the cursor

Line and lineseries objects have an additional field.

DataIndex	A scalar index into the data arrays that correspond to the nearest data point. The value is the same for each array.
-----------	--

See “Output Arguments” on page 1-1511 for more details on data cursor mode objects.

Examples

This example creates a plot and enables data cursor mode from the command line.

```
surf(peaks)
datacursormode on
% Click mouse on surface to display data cursor
```

Selecting a point on the surface opens a data tip displaying its x -, y -, and z -coordinates.

datacursormode

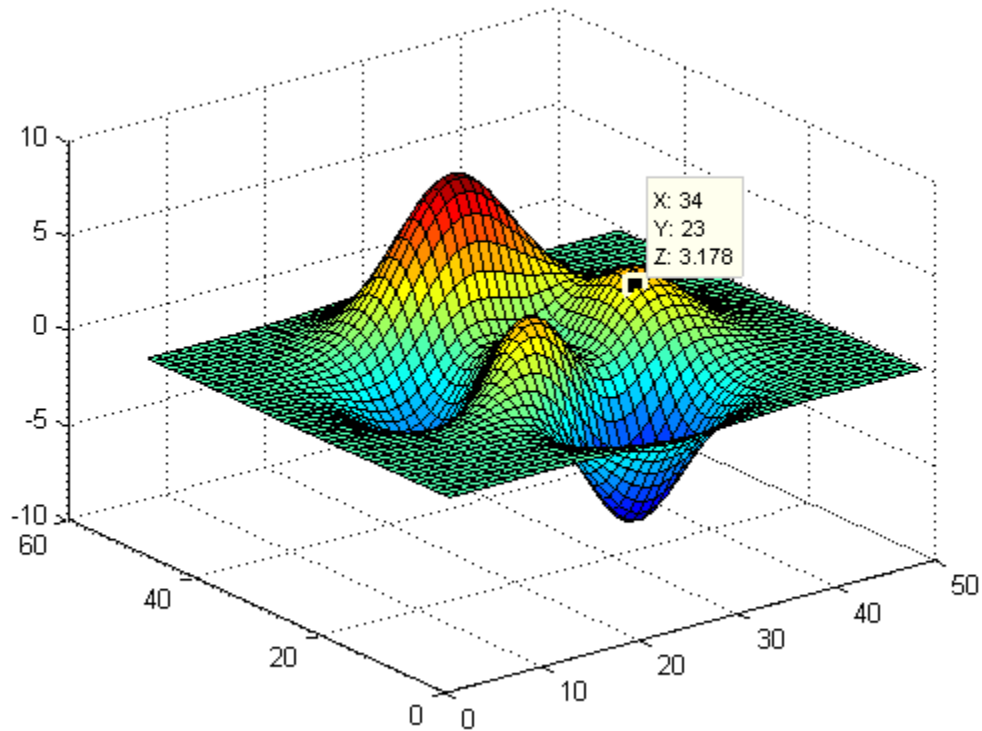

You change the data tip display style to be a window instead of a text box using the **Tools > Options > Display cursor in window**, or use the context menu **Display Style > Window inside figure** to view the data tip in a floating window that you can move around inside the axes.

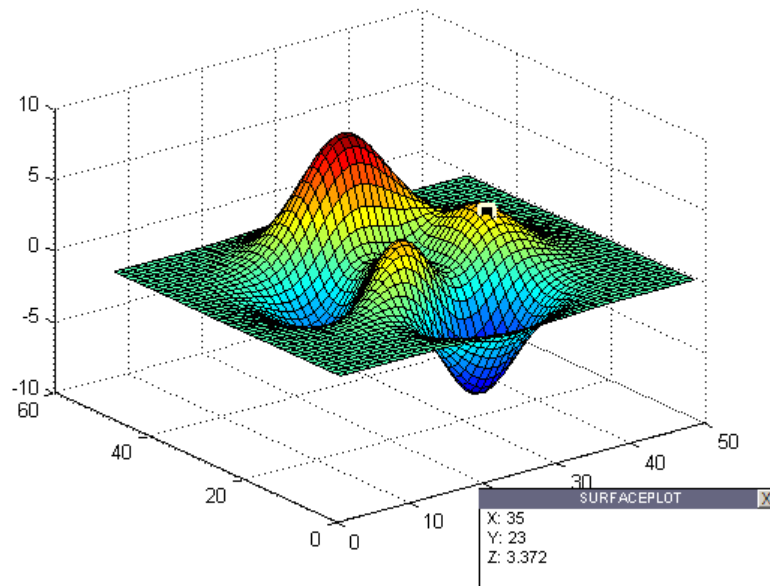

You can position multiple text box data tips on the same graph, the window style of data tip displays only one value at a time. For more information on interacting with data cursors, including point selection options and exporting data tips to the workspace, see “Data Cursor — Displaying Data Values Interactively”.

This example enables data cursor mode on the current figure and sets data cursor mode options. The following statements

- Create a graph
- Toggle data cursor mode to on
- Obtain the data cursor mode object, specify data tip options, and get the handle of the line the data tip occupies:

```
fig = figure;
z = peaks;
plot(z(:,30:35))
```

datacursormode

```
dcm_obj = datacursormode(fig);  
set(dcm_obj, 'DisplayStyle', 'datatip', ...  
    'SnapToDataVertex', 'off', 'Enable', 'on')  
  
disp('Click line to display a data tip, then press Return.')  
% Wait while the user does this.  
pause  
  
c_info = getCursorInfo(dcm_obj);  
% Make selected line wider  
set(c_info.Target, 'LineWidth', 2)
```

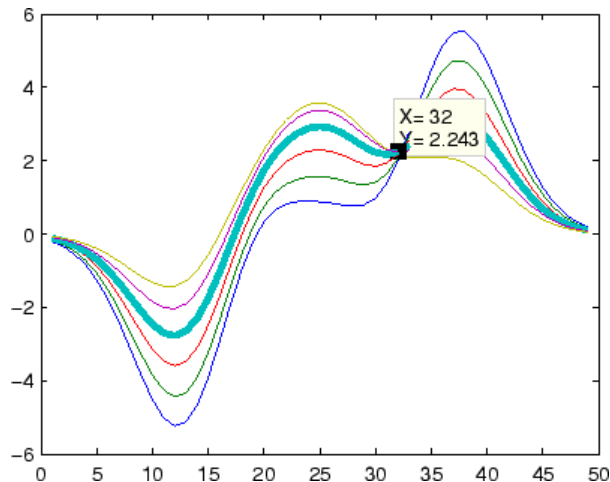

This example shows you how to customize the text that the data cursor displays. For example, you can replace the text displayed in the data tip and data window (x: and y:) with Time: and Amplitude: by creating a simple update function.

Save the following functions in your current directory or any writable directory on the MATLAB path before running them. As they are functions, you cannot highlight them and then evaluate the selection to make them work.

Save this code as `doc_datacursormode.m`:

```
function doc_datacursormode
% Plots graph and sets up a custom data tip update function
fig = figure;
a = -16; t = 0:60;
plot(t,sin(a*t))
dcm_obj = datacursormode(fig);
set(dcm_obj, 'UpdateFcn', @myupdatefcn)
```

Save the following code as `myupdatefcn.m` on the MATLAB path:

```
function txt = myupdatefcn(empty,event_obj)
% Customizes text of data tips

pos = get(event_obj, 'Position');
txt = {['Time: ', num2str(pos(1))], ...
      ['Amplitude: ', num2str(pos(2))]};
```

To set up and use the update function, type:

```
doc_datacursormode
```

When you place a data tip using this update function, it looks like the one in the following figure.

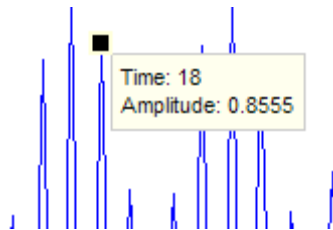

Alternatives

Use the Data Cursor tool  to label x , y , and z values on graphs and surfaces. You can control how data tips display by right-clicking and selecting items from the context menu.

datacursormode

See Also

`brush` | `pan` | `rotate3d` | `zoom`

Tutorials

- “Data Cursor — Displaying Data Values Interactively”

How To

- “Example — Visually Exploring Demographic Statistics”
- “Data Cursors with Histograms”

Purpose Produce short description of input variable

Syntax `datatipinfo(var)`

Description `datatipinfo(var)` displays a short description of a variable, similar to what is displayed in a `datatip` in the MATLAB debugger.

Examples Get `datatip` information for a 5-by-5 matrix:

```
A = rand(5);
```

```
datatipinfo(A)
```

```
A: 5x5 double =  
    0.4445    0.3567    0.7458    0.0767    0.4400  
    0.7962    0.6575    0.3918    0.8289    0.9746  
    0.5641    0.9808    0.0265    0.4838    0.6722  
    0.9099    0.9653    0.2508    0.4859    0.4054  
    0.2857    0.5198    0.7383    0.9301    0.9604
```

Get `datatip` information for a 50-by-50 matrix. For this larger matrix, `datatipinfo` displays just the size and data type:

```
A = rand(50);
```

```
datatipinfo(A)
```

```
A: 50x50 double
```

Also for multidimensional matrices, `datatipinfo` displays just the size and data type:

```
A = rand(5);
```

```
A(:,:,2) = A(:,:,1);
```

```
datatipinfo(A)
```

```
A: 5x5x2 double
```

See Also `inputname` | `narginchk` | `nargin` | `varargin` | `inputParser`

date

Purpose Current date string

Syntax `str = date`

Description `str = date` returns a string containing the date in dd-mmm-yyyy format.

See Also `clock` | `datestr` | `datenum` | `now`

Purpose

Convert date and time to serial date number

Syntax

```
DateNumber = datenum(DateString)
DateNumber = datenum(DateString,formatIn)
DateNumber = datenum(DateString,PivotYear)
DateNumber = datenum(DateString,formatIn,PivotYear)
```

```
DateNumber = datenum(DateVector)
DateNumber = datenum(Y,M,D)
DateNumber = datenum(Y,M,D,H,MN,S)
```

Description

`DateNumber = datenum(DateString)` converts date strings to serial date numbers. If the date string format is known, use `formatIn`. Syntaxes without `formatIn` are significantly slower than those that include it.

A serial date number represents the whole and fractional number of days from a fixed, preset date (January 0, 0000).

`DateNumber = datenum(DateString,formatIn)` uses `formatIn` to interpret each date string.

`DateNumber = datenum(DateString,PivotYear)` uses `PivotYear` to interpret date strings that specify the year as two characters. If the date string format is known, use `formatIn`. Syntaxes without `formatIn` are significantly slower than those that include it.

`DateNumber = datenum(DateString,formatIn,PivotYear)` uses `formatIn` to interpret each date string, and `PivotYear` to interpret date strings that specify the year as two characters. You can specify `formatIn` and `PivotYear` in either order.

`DateNumber = datenum(DateVector)` converts date vectors to serial date numbers, and returns a column vector of `m` date numbers, where `m` is the total number of date vectors in `DateVector`.

`DateNumber = datetime(Y,M,D)` returns the serial date numbers for corresponding elements of the Y, M, and D (year, month, day) arrays. The arrays must be of the same size (or any can be a scalar). You can also specify the input arguments as a date vector, [Y,M,D].

`DateNumber = datetime(Y,M,D,H,MN,S)` additionally returns the serial date numbers for corresponding elements of the H, MN, and S (hour, minute, and second) arrays. The arrays must be of the same size (or any can be a scalar). You can also specify the input arguments as a date vector, [Y,M,D,H,MN,S].

Input Arguments

DateVector - Date vectors

matrix

Date vectors, specified as an *m*-by-6 or *m*-by-3 matrix containing *m* full or partial date vectors, respectively. A full date vector has six elements, specifying year, month, day, hour, minute, and second, in that order. A partial date vector has three elements, specifying year, month, and day, in that order. Each element of `DateVector` should be a positive or negative integer value with the exception of the seconds element, which can be fractional. If an element falls outside the conventional range, MATLAB adjusts both that date vector element and the previous element. For example, if the minutes element is 70, MATLAB adjusts the hours element by 1 and sets the minutes element to 10. If the minutes element is -15, then MATLAB decreases the hours element by 1 and sets the minutes element to 45. Month values are an exception. MATLAB sets month values less than 1 to 1.

Example: [2003,10,24,12,45,07]

Data Types

double

DateString - Date strings

string | character array | 1-D cell array of strings

Date strings, specified as a character array where each row corresponds to one date string, or as a one dimensional cell array of strings. All of the date strings must have the same format.

Example: '24 Oct-2003 12:45:07'

Example: ['19-Sep-2013'; '20-Sep-2013'; '21-Sep-2013']

Example: {'15-Oct-2010' '20-Nov-2012'}

If the date string format is known, you should also specify `formatIn`. If you do not specify `formatIn`, `DateString` must be in one of the following formats.

Date String Format	Example
'dd-mmm-yyyy HH:MM:SS'	01-Mar-2000 15:45:17
'dd-mmm-yyyy'	01-Mar-2000
'mm/dd/yyyy'	03/01/2000
'mm/dd/yy'	03/01/00
'mm/dd'	03/01
'mmm.dd,yyyy HH:MM:SS'	Mar.01,2000 15:45:17
'mmm.dd,yyyy'	Mar.01,2000
'yyyy-mm-dd HH:MM:SS'	2000-03-01 15:45:17
'yyyy-mm-dd'	2000-03-01
'yyyy/mm/dd'	2000/03/01
'HH:MM:SS'	15:45:17
'HH:MM:SS PM'	3:45:17 PM
'HH:MM'	15:45
'HH:MM PM'	3:45 PM

Certain date string formats might not contain enough information to convert the date string. In those cases, hours, minutes, and seconds default to 0, days default to 1, months default to January, and years

default to the current year. MATLAB considers two-character date string years (e.g., '79') to fall within the 100-year range centered around the current year.

When you do not specify `formatIn`, note the following:

- For the formats that specify the month as two digits (mm), the month value must not be greater than 12.
- However, for the format 'mm/dd/yy', if the first entry in the date string is greater than 12 and the second entry is less than or equal to 12, MATLAB considers the date string to be in 'yy/mm/dd' format.

formatIn - Format of the input date string

string

Format of the input date string, specified as a string of symbolic identifiers.

Example: 'dddd, mmm dd, yyyy'

The following table shows symbolic identifiers you can use to construct the `formatIn` string. You can include characters such as a hyphen, space, or colon to separate the fields.

Symbolic Identifier	Description	Example
yyyy	Year in full	1990, 2002
yy	Year in two digits	90, 02
QQ	Quarter year using letter Q and one digit	Q1
mmmm	Month using full name	March, December
mmm	Month using first three letters	Mar, Dec
mm	Month in two digits	03, 12

Symbolic Identifier	Description	Example
m	Month using capitalized first letter	M, D
dddd	Day using full name	Monday, Tuesday
ddd	Day using first three letters	Mon, Tue
dd	Day in two digits	05, 20
d	Day using capitalized first letter	M, T
HH	Hour in two digits (no leading zeros when symbolic identifier AM or PM is used)	05, 5 AM
MM	Minute in two digits	12, 02
SS	Second in two digits	07, 59
FFF	Millisecond in three digits	057
AM or PM	AM or PM inserted in date string	3:45:02 PM

The formatIn string must follow these guidelines:

- You cannot specify any field more than once. For example, you cannot use 'yy-mmm-dd-m' because it has two month identifiers. The one exception to this is that you can combine one instance of dd with one instance of any of the other day identifiers. For example, 'dddd mmm dd yyyy' is a valid input.
- When you use AM or PM, the HH field is also required.
- You only can use QQ alone or with a year specifier.

PivotYear - Start year of 100-year date range

present minus 50 years (default) | integer

Start year of the 100-year date range in which a two-character year resides, specified as an integer. Use a pivot year to interpret date strings that specify the year as two characters.

If `formatIn` contains the time of day, the pivot year is computed from the current time of the current day, month, and year. Otherwise it is computed from midnight of the current day, month, and year.

Example: 2000

Data Types

double

Y,M,D - Year, month, and day arrays

scalar | vector | matrix | array

Year, month, and day arrays specified as a scalar, vector, matrix or array. These must be the same size, or any one can be a scalar. Y,M,D should be integer values.

If Y,M,D are all scalars or all column vectors, you can specify the input arguments as a date vector, [Y,M,D].

Example: 2003,10,24

Data Types

double

Y,M,D,H,MN,S - Year, month, day, hour, minute and second arrays

scalar | vector | matrix | array

Year, month, day, hour, minute and second arrays specified as a scalar, vector, matrix or array. These must be the same size, or any one can be a scalar. `datenum` does not accept milliseconds as a separate input, but as a fractional part of the seconds input, S. Y,M,D,H,MN should be integer values.

If Y,M,D,H,MN,S are all scalars or all column vectors, you can specify the input arguments as a date vector[Y,M,D,H,MN,S].

Example: 2003,10,24,12,45,07.451

Data Types

double

Output Arguments**DateNumber - Serial date numbers**

scalar | vector

Serial date numbers, returned as a column vector of length m , where m is the total number of input date vectors or date strings.

Tips

- To create arbitrarily shaped output, use `thedatenum(Y,M,D)` and `datenum(Y,M,D,H,MN,S)` syntaxes. The `datenum(DateVector)` syntax creates only a column vector of date numbers.

```
datenum(2013,[1 3; 2 4],ones(2,2))
```

```
ans =
```

```
    735235    735294
    735266    735325
```

Examples**Convert Date String to Date Number**

```
DateString = '19-May-2001';
formatIn = 'dd-mmm-yyyy';
datenum(DateString,formatIn)
```

```
ans =
```

```
    730990
```

`datenum` returns a date number for the date string with the format 'dd-mmm-yyyy'.

Convert Multiple Date Strings to Date Numbers

Pass multiple date strings in a cell array. All input date strings must use the same format.

datenum

```
DateString = {'09/16/2007';'05/14/1996';'11/29/2010'};  
formatIn = 'mm/dd/yyyy';  
datenum(DateString,formatIn)
```

```
ans =
```

```
733301  
729159  
734471
```

Convert Date String to Date Number Using Pivot Year

Convert a date string to a serial date number using the default pivot year.

```
n = datenum('12-jun-17','dd-mmm-yy')
```

```
n =
```

```
736858
```

The corresponding date string to this date number is 12-Jun-2017.

Convert the same date string to a serial date number using 1400 as the pivot year.

```
n = datenum('12-jun-17','dd-mmm-yy',1400)
```

```
n =
```

```
517712
```

The corresponding date string to this date number is 12-Jun-1417.

Convert Date Vector to Date Number

```
datenum([2009,4,2,11,7,18])
```

```
ans =
```

```
7.3387e+05
```

Convert Year, Month, and Day to Date Number

Convert a date specified by year, month and day values to a serial date number.

```
n = datenum(2001,12,19)
```

```
n =
```

```
731204
```

See Also

[datestr](#) | [datevec](#)

Concepts

- “Represent Dates and Times in MATLAB”
- “Carryover in Date Vectors and Strings”

datestr

Purpose Convert date and time to string format

Syntax

```
DateString = datestr(DateVector)
DateString = datestr(DateNumber)

DateString = datestr(___,formatOut)

DateString = datestr(DateStringIn)
DateString = datestr(DateStringIn,formatOut,PivotYear)

DateString = datestr(___, 'local')
```

Description `DateString = datestr(DateVector)` converts date vectors to date strings. `datestr` returns a column vector of `m` date strings, where `m` is the total number of date vectors in `DateVector`. `datestr` returns date strings in the default date string format `dd-mmm-yyyy HH:MM:SS` (day-month-year hour:minute:second). By default, if `HH:MM:SS = 00:00:00` then the date string returned has the format `dd-mmm-yyyy`.

`DateString = datestr(DateNumber)` converts serial date numbers to date strings. `datestr` returns a column vector of `m` date strings, where `m` is the total number of date numbers in `DateNumber`.

`DateString = datestr(___,formatOut)` specifies the format of the output date strings using `formatOut`. You can use `formatOut` with any of the input arguments in the above syntaxes.

`DateString = datestr(DateStringIn)` converts `DateStringIn` to date strings in the default date string format `dd-mmm-yyyy HH:MM:SS`. All date strings in `DateStringIn` must have the same format.

`DateString = datestr(DateStringIn,formatOut,PivotYear)` converts `DateStringIn` to `DateString`, in the format specified by `formatOut`, and using optional `PivotYear` to interpret date strings that specify the year as two characters.

`DateString = datestr(___, 'local')` returns the date string in the language of the current locale. This is the language you select by means of your computer's operating system. If you leave `local` out of the argument list, `datestr` returns the date string in the default language, which is US English. Use `local` with any of the previous syntaxes. The `local` argument must be last in the argument sequence.

Input Arguments

DateVector - Date vectors

matrix

Date vectors, specified as an `m`-by-6 matrix, where `m` is the number of full (six-element) date vectors. Each element of `DateVector` should be a positive or negative integer value with the exception of the seconds element, which can be fractional. If an element falls outside the conventional range, MATLAB adjusts both that date vector element and the previous element. For example, if the minutes element is 70, MATLAB adjusts the hours element by 1 and sets the minutes element to 10. If the minutes element is -15, then MATLAB decreases the hours element by 1 and sets the minutes element to 45. Month values are an exception. MATLAB sets month values less than 1 to 1.

Example: `[2003,10,24,12,45,07]`

Data Types

double

DateNumber - Serial date numbers

scalar | vector | matrix | array

Serial date numbers, specified as a scalar, vector, matrix, or array of positive double-precision numbers.

Example: `731878`

Data Types

double

formatOut - Format of the date string output

-1 (default) | string | integer

datestr

Format of the date string output, specified as a string of symbolic identifiers or an integer that corresponds to a predefined format. If you do not specify `formatOut`, `datestr` returns a date string in the default date string format `dd-mmm-yyyy HH:MM:SS` (day-month-year hour:minute:second). By default, if `HH:MM:SS = 00:00:00` then the date string returned has the format `dd-mmm-yyyy`.

The following table shows symbolic identifiers you can use to construct the `formatOut` string. You can include characters such as a hyphen, space, or colon to separate the fields.

Symbolic Identifier	Description	Example
yyyy	Year in full	1990, 2002
yy	Year in two digits	90, 02
QQ	Quarter year using letter Q and one digit	Q1
mmmm	Month using full name	March, December
mmm	Month using first three letters	Mar, Dec
mm	Month in two digits	03, 12
m	Month using capitalized first letter	M, D
dddd	Day using full name	Monday, Tuesday
ddd	Day using first three letters	Mon, Tue
dd	Day in two digits	05, 20
d	Day using capitalized first letter	M, T

Symbolic Identifier	Description	Example
HH	Hour in two digits (no leading zeros when symbolic identifier AM or PM is used)	05, 5 AM
MM	Minute in two digits	12, 02
SS	Second in two digits	07, 59
FFF	Millisecond in three digits	057
AM or PM	AM or PM inserted in date string	3:45:02 PM

The formatOut string must follow these guidelines:

- You cannot specify any field more than once. For example, you cannot use 'yy-mmm-dd-m' because it has two month identifiers. The one exception to this is that you can combine one instance of dd with one instance of any of the other day identifiers. For example, 'dddd mmm dd yyyy' is a valid input.
- When you use AM or PM, the HH field is also required.
- You only can use QQ alone or with a year specifier.

The following table lists predefined MATLAB date formats.

Numeric Identifier	Date String Format	Example
-1 (default)	'dd-mmm-yyyy HH:MM:SS' or 'dd-mmm-yyyy' if 'HH:MM:SS' = 00:00:00	01-Mar-2000 15:45:17 or 01-Mar-2000
0	'dd-mmm-yyyy HH:MM:SS'	01-Mar-2000 15:45:17
1	'dd-mmm-yyyy'	01-Mar-2000

datestr

Numeric Identifier	Date String Format	Example
2	'mm/dd/yy'	03/01/00
3	'mmm'	Mar
4	'm'	M
5	'mm'	03
6	'mm/dd'	03/01
7	'dd'	01
8	'ddd'	Wed
9	'd'	W
10	'yyyy'	2000
11	'yy'	00
12	'mmyy'	Mar00
13	'HH:MM:SS'	15:45:17
14	'HH:MM:SS PM'	3:45:17 PM
15	'HH:MM'	15:45
16	'HH:MM PM'	3:45 PM
17	'QQ-YY'	Q1-01
18	'QQ'	Q1
19	'dd/mm'	01/03
20	'dd/mm/yy'	01/03/00
21	'mmm.dd,yyyy HH:MM:SS'	Mar.01,2000 15:45:17
22	'mmm.dd,yyyy'	Mar.01,2000
23	'mm/dd/yyyy'	03/01/2000
24	'dd/mm/yyyy'	01/03/2000
25	'yy/mm/dd'	00/03/01

Numeric Identifier	Date String Format	Example
26	'yyyymmdd'	2000/03/01
27	'QQ-YYYY'	Q1-2001
28	'mmmyyyy'	Mar2000
29	'yyyy-mm-dd' (ISO 8601)	2000-03-01
30	'yyyymmddTHHMMSS' (ISO 8601)	20000301T154517
31	'yyyy-mm-dd HH:MM:SS'	2000-03-01 15:45:17

DateStringIn - Date strings to convert

string | cell array

Date strings to convert, specified as a single string or a cell array of strings, where each row corresponds to one date string.

MATLAB considers two-character date string years (for example, '79') to fall within the 100-year range centered around the current year.

All date strings must have the same date format, and they must be in one of the following MATLAB date formats.

Date String Format	Example
'dd-mmm-yyyy HH:MM:SS'	01-Mar-2000 15:45:17
'dd-mmm-yyyy'	01-Mar-2000
'mm/dd/yyyy'	03/01/2000
'mm/dd/yy'	03/01/00
'mm/dd'	03/01
'mmm.dd,yyyy HH:MM:SS'	Mar.01,2000 15:45:17
'mmm.dd,yyyy'	Mar.01,2000

Date String Format	Example
'yyyy-mm-dd HH:MM:SS'	2000-03-01 15:45:17
'yyyy-mm-dd'	2000-03-01
'yyyy/mm/dd'	2000/03/01
'HH:MM:SS'	15:45:17
'HH:MM:SS PM'	3:45:17 PM
'HH:MM'	15:45
'HH:MM PM'	3:45 PM

Note When converting from one date string format to another, you should first pass the strings to the `datenum` function, so that you can specify the format of the input date strings. This ensures that the format of the input date strings is correctly interpreted. For example, see “Convert Date String from Custom Format” on page 1-1541.

PivotYear - Start year of 100-year date range

present minus 50 years (default) | integer

Start year of the 100-year date range in which a two-character year resides, specified as an integer. Use a pivot year to interpret date strings that specify the year as two characters.

If `formatIn` contains the time of day, the pivot year is computed from the current time of the current day, month, and year. Otherwise it is computed from midnight of the current day, month, and year.

Example: 2000

Data Types

double

Output Arguments

DateString - Date strings

string | two-dimensional character array

Date strings, returned as a character array with *m* rows, where *m* is the total number of input date vectors, serial date numbers, or date strings. The default output date string format is `dd-mmm-yyyy HH:MM:SS` (day-month-year hour:minute:second) unless the hours, minutes and seconds are all 0 in which case `HH:MM:SS` is suppressed.

Tips

- To convert a date string not in a predefined MATLAB date format, first convert the date string to a date number, using either `datenum` or `datevec`.

Examples

Convert Date Vector to Date String

```
DateVector = [2009,4,2,11,7,18];
```

```
datestr(DateVector)
```

```
ans =
```

```
02-Apr-2009 11:07:18
```

`datestr` returns a date string in the default date string format.

Convert Date and Time to Specific Format

Format the current date in the `mm/dd/yy` format.

You can specify this format using a string of symbolic identifiers.

```
formatOut = 'mm/dd/yy';  
datestr(now,formatOut)
```

```
ans =
```

datestr

```
01/17/14
```

Alternatively, you can specify this format using a numeric identifier.

```
formatOut = 2;  
datestr(now,formatOut)
```

```
ans =
```

```
01/17/14
```

You can reformat the date and time, and also show milliseconds.

```
dt = datestr(now,'mmm dd, yyyy HH:MM:SS.FFF AM')
```

```
dt =
```

```
January 17, 2014 3:51:01.740 PM
```

Convert 12-Hour Time String to 24-Hour Equivalent

Convert the 12-hour time 05:32 p.m. to its 24-hour equivalent.

```
datestr('05:32 PM','HH:MM')
```

```
ans =
```

```
17:32
```

Convert the 24-hour time 05:32 to its 12-hour equivalent.

```
datestr('05:32','HH:MM PM')
```

```
ans =
```

```
5:32 AM
```

The use of AM or PM in the `formatOut` string does not influence which characters actually become part of the date string; they only determine whether or not to include them in the date string. MATLAB® selects AM or PM based on the time entered.

Convert Date String from Custom Format

Call `datenum` inside of `datestr` to specify the format of the input date string.

```
formatOut = 'dd mmm yyyy';  
datestr(datenum('16-04-55','dd-mm-yy',1900),formatOut)
```

```
ans =
```

```
16 Apr 1955
```

Convert Multiple Date Strings

Convert more than one date string input by passing the multiple date strings in a cell array.

All input date strings must use the same format. For example, the following command passes three dates that all use the `mm/dd/yyyy` format.

```
datestr(datenum({'09/16/2007';'05/14/1996';'11/29/2010'}), ...  
        'mm/dd/yyyy')
```

```
ans =
```

```
16-Sep-2007  
14-May-1996  
29-Nov-2010
```

`datestr` returns a character array of converted date strings in the default date string format.

Convert Date String with Values Outside Normal Range

Call `datenum` inside of `datestr` to return the expected value, because the date below uses a value outside its normal range (`month=13`).

```
datestr(datenum('13/24/88','mm/dd/yy'))
```

```
ans =
```

```
24-Jan-1989
```

Use a Pivot Year

Change the pivot year to change the year range.

Use a pivot year of 1900.

```
DateStringIn = '4/16/55';  
formatOut = 1;  
PivotYear = 1900;  
datestr(DateStringIn,formatOut,PivotYear)
```

```
ans =
```



```
16-Apr-1955
```

For the same date string, use a pivot year of 2000.

```
PivotYear = 2000;  
datestr(DateStringIn,formatOut,PivotYear)
```

```
ans =
```

```
16-Apr-2055
```

Return Date String in Local Language

Convert a date number to a date string in the language of the current locale.

Use the `local` argument in a French locale.

```
DateNumber = 725935;  
formatOut = 'mmm-dd-yyyy';  
str = datestr(DateNumber,formatOut,'local')
```

```
str =  
Juillet-17-1987
```

You can make the same call without specifying `'local'`.

```
str = datestr(DateNumber,formatOut)
```

```
str =  
July-17-1987
```

In this case, the output defaults to the English language.

datestr

See Also

[datetime](#) | [datevec](#)

Concepts

- [“Represent Dates and Times in MATLAB”](#)
- [“Troubleshooting: Converting Date Vector Returns Unexpected Output”](#)

Purpose

Date formatted tick labels

Syntax

```
datetick(tickaxis)  
datetick(tickaxis,dateFormat)
```

```
datetick( __ , 'keeplimits')
```

```
datetick( __ , 'keepticks')
```

```
datetick(axes_handle, __ )
```

Description

`datetick(tickaxis)` labels the tick lines of the axis specified by `tickaxis` using dates, replacing the default numeric labels. `datetick` selects a label format based on the minimum and maximum limits of the specified axis. The axis data values should be serial date numbers, as returned by the `datenum` function.

`datetick(tickaxis,dateFormat)` formats the labels according to the string `dateFormat`.

`datetick(__ , 'keeplimits')` changes the tick labels to date-based labels while preserving the axis limits. Append `'keeplimits'` to any of the previous syntaxes.

`datetick(__ , 'keepticks')` changes the tick labels to date-based labels while preserving their locations. Append `'keepticks'` to any of the previous syntaxes.

`datetick(axes_handle, __)` labels the tick lines of an axis on the axes specified by `axes_handle`. The `axes_handle` argument can precede any of the input argument combinations in the previous syntaxes.

datetick

Input Arguments

tickaxis - Axis to label

'x' (default) | 'y' | 'z'

Axis to label with dates, specified as 'x', 'y', or 'z'.

dateFormat - Format of tick line labels

string | integer

Format of the tick line labels, specified as a string of symbolic identifiers or an integer that corresponds to a predefined format.

The following table shows symbolic identifiers you can use to construct the `dateFormat` string. You can include characters such as a hyphen, space, or colon to separate the fields. For example, to display the day of the month followed by the three-letter abbreviation of the day of the week in parentheses, use `dateFormat = 'dd (ddd)'`.

Symbolic Identifier	Description	Example
yyyy	Year in full	1990, 2002
yy	Year in two digits	90, 02
QQ	Quarter year using letter Q and one digit	Q1
mmm	Month using full name	March, December
mmm	Month using first three letters	Mar, Dec
mm	Month in two digits	03, 12
m	Month using capitalized first letter	M, D
dddd	Day using full name	Monday, Tuesday
ddd	Day using first three letters	Mon, Tue
dd	Day in two digits	05, 20

Symbolic Identifier	Description	Example
d	Day using capitalized first letter	M, T
HH	Hour in two digits (no leading zeros when symbolic identifier AM or PM is used)	05, 5 AM
MM	Minute in two digits	12, 02
SS	Second in two digits	07, 59
FFF	Millisecond in three digits	057
AM or PM	AM or PM inserted in date string	3:45:02 PM

The following table lists predefined MATLAB date formats.

Numeric Identifier	Date String Format	Example
-1 (default)	'dd-mmm-yyyy HH:MM:SS' or 'dd-mmm-yyyy' if 'HH:MM:SS' = 00:00:00	01-Mar-2000 15:45:17 or 01-Mar-2000
0	'dd-mmm-yyyy HH:MM:SS'	01-Mar-2000 15:45:17
1	'dd-mmm-yyyy'	01-Mar-2000
2	'mm/dd/yy'	03/01/00
3	'mmm'	Mar
4	'm'	M
5	'mm'	03
6	'mm/dd'	03/01

Numeric Identifier	Date String Format	Example
7	'dd'	01
8	'ddd'	Wed
9	'd'	W
10	'yyyy'	2000
11	'yy'	00
12	'mmyy'	Mar00
13	'HH:MM:SS'	15:45:17
14	'HH:MM:SS PM'	3:45:17 PM
15	'HH:MM'	15:45
16	'HH:MM PM'	3:45 PM
17	'QQ-YY'	Q1-01
18	'QQ'	Q1
19	'dd/mm'	01/03
20	'dd/mm/yy'	01/03/00
21	'mmm.dd,yyyy HH:MM:SS'	Mar.01,2000 15:45:17
22	'mmm.dd,yyyy'	Mar.01,2000
23	'mm/dd/yyyy'	03/01/2000
24	'dd/mm/yyyy'	01/03/2000
25	'yy/mm/dd'	00/03/01
26	'yyyy/mm/dd'	2000/03/01
27	'QQ-YYYY'	Q1-2001
28	'mmyyyy'	Mar2000
29	'yyyy-mm-dd' (ISO 8601)	2000-03-01

Numeric Identifier	Date String Format	Example
30	'yyymmddTHMMSS' (ISO 8601)	20000301T154517
31	'yyyy-mm-dd HH:MM:SS'	2000-03-01 15:45:17

Examples

Label x-Axis Ticks with 2-digit Years

Graph population data for the 20th Century taken from the 1990 US census and label x -axis ticks with 2-digit years.

Create time data by decade.

```
t = (1900:10:1990)';
```

Enter total population counts for the USA.

```
p = [75.995 91.972 105.711 123.203 131.669 ...  
150.697 179.323 203.212 226.505 249.633]';
```

Convert years to serial date numbers using the `datenum` function, and then plot the data.

```
figure  
plot(datenum(t,1,1),p)  
grid on
```

datetick

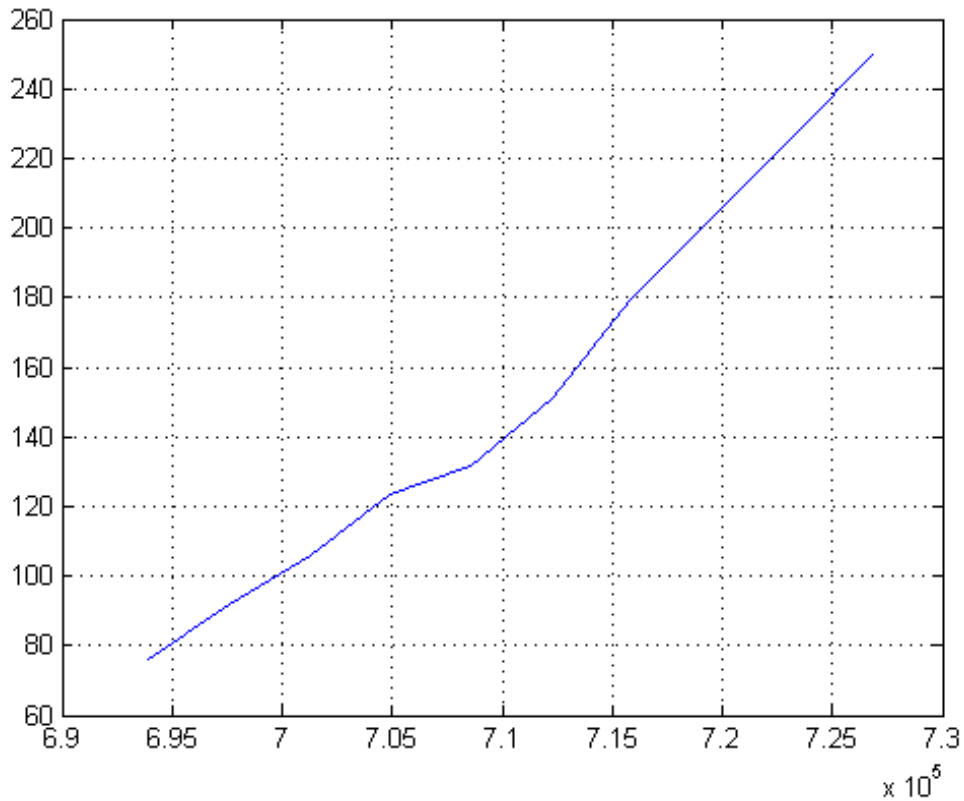

Replace *x*-axis ticks with 2-digit years. The numeric identifier 11 corresponds to the predefined MATLAB® date format 'yy'.

```
dateFormat = 11;  
datetick('x',dateFormat)
```

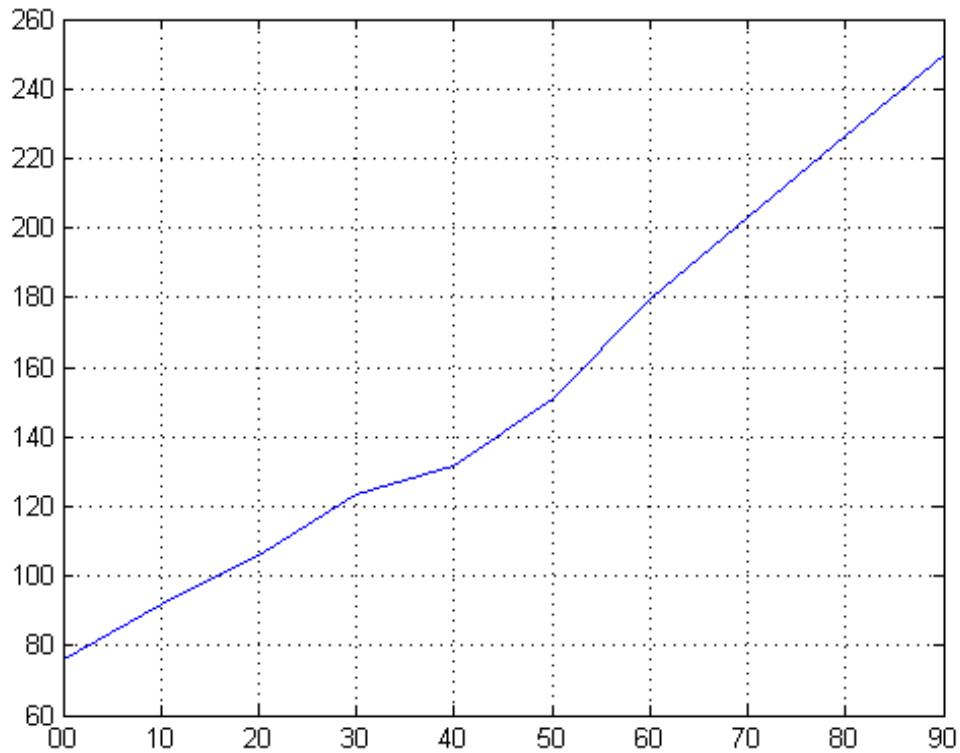
Label x-Axis Ticks with Hours of the Day

Plot traffic count data against date ticks for hours of the day showing AM and PM.

Get traffic count data.

```
load count.dat
```

Create arrays for an arbitrary date, for example, April 18, 1995.

```
n = length(count);  
year = 1990 * ones(1,n);  
month = 4 * ones(1,n);  
day = 18 * ones(1,n);
```

Create arrays for each of 24 hours.

```
hour = 1:n;  
minutes = zeros(1,n);
```

Get the serial date numbers for the date arrays.

```
xdate = datenum(year,month,day,hour,minutes,minutes);
```

Plot the traffic data against the serial date numbers.

```
figure  
plot(xdate,count)
```

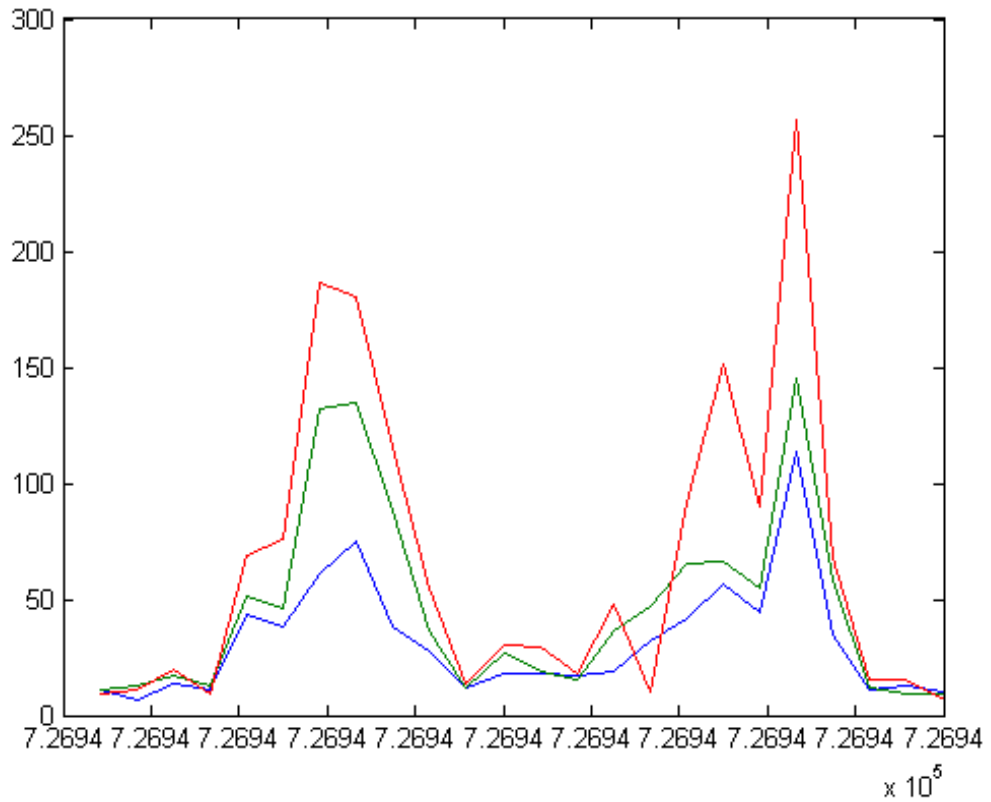

Label the tick lines of the graph's x-axis with the hours of the day.

```
datetick('x','HHPM')
```

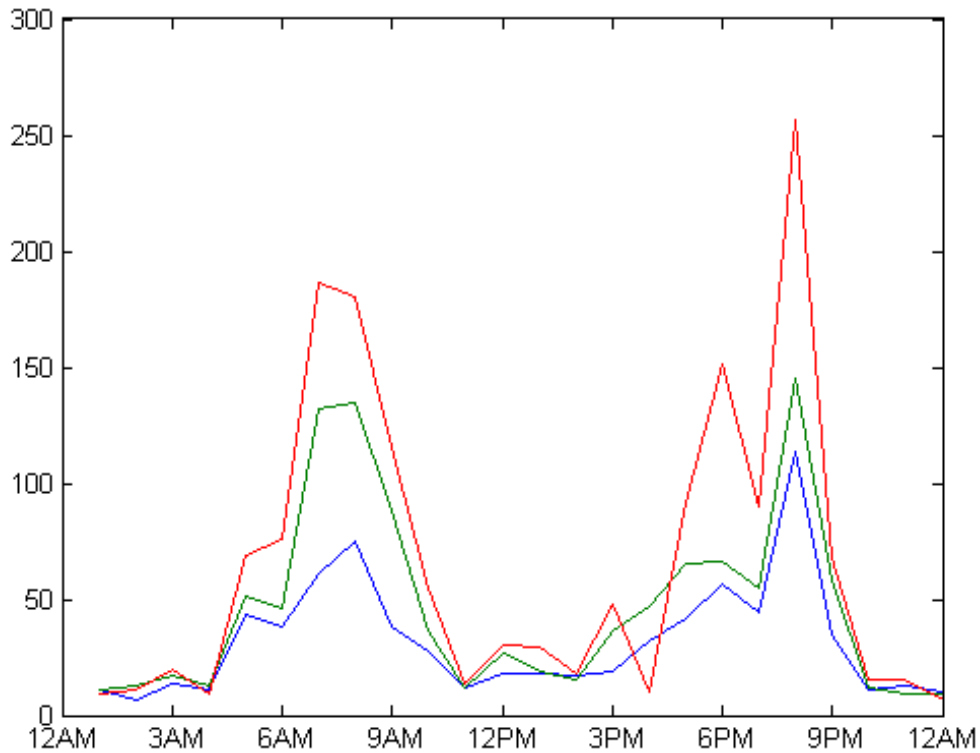

Label x-Axis and Preserve Axis Limits

Select a starting date.

```
startDate = datenum('02-01-1962');
```

Select an ending date.

```
endDate = datenum('11-15-2012');
```

Create a variable, `xdata`, that corresponds to the number of years between the start and end dates.

```
xData = linspace(startDate, endDate, 50);
```

Plot random data.

```
figure  
plot(xData, rand(1, 50))
```

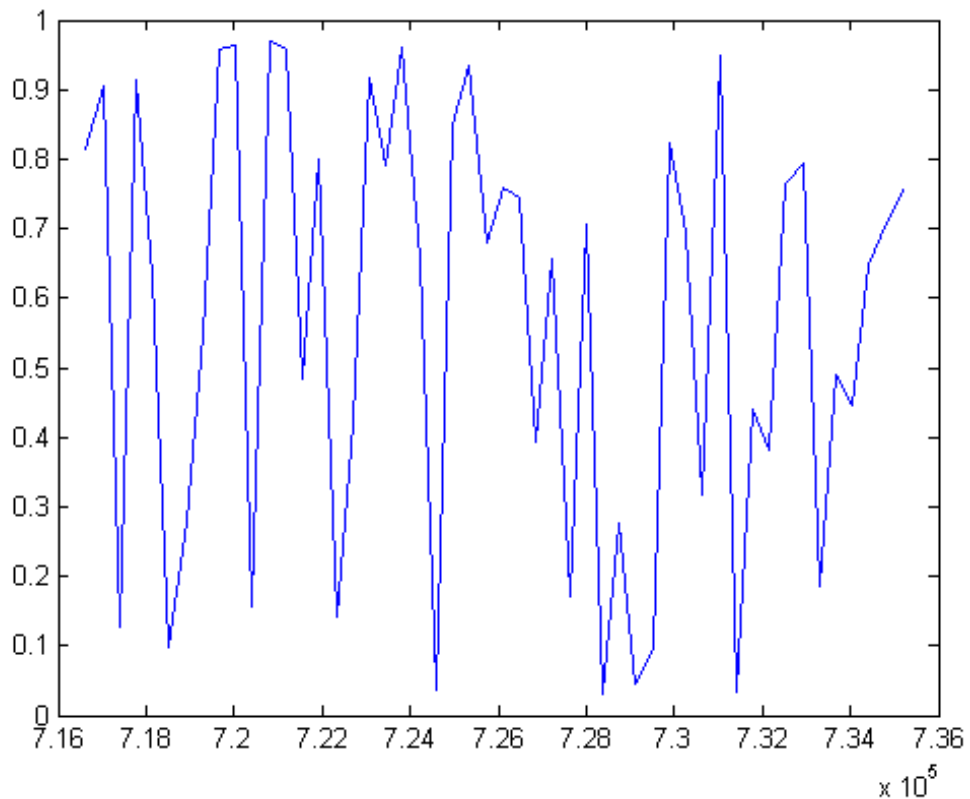

datetick

Label the x -axis with 4-digit years, preserving the x -axis limits by using the 'keeplimits' option.

```
datetick('x','yyyy','keeplimits')
```

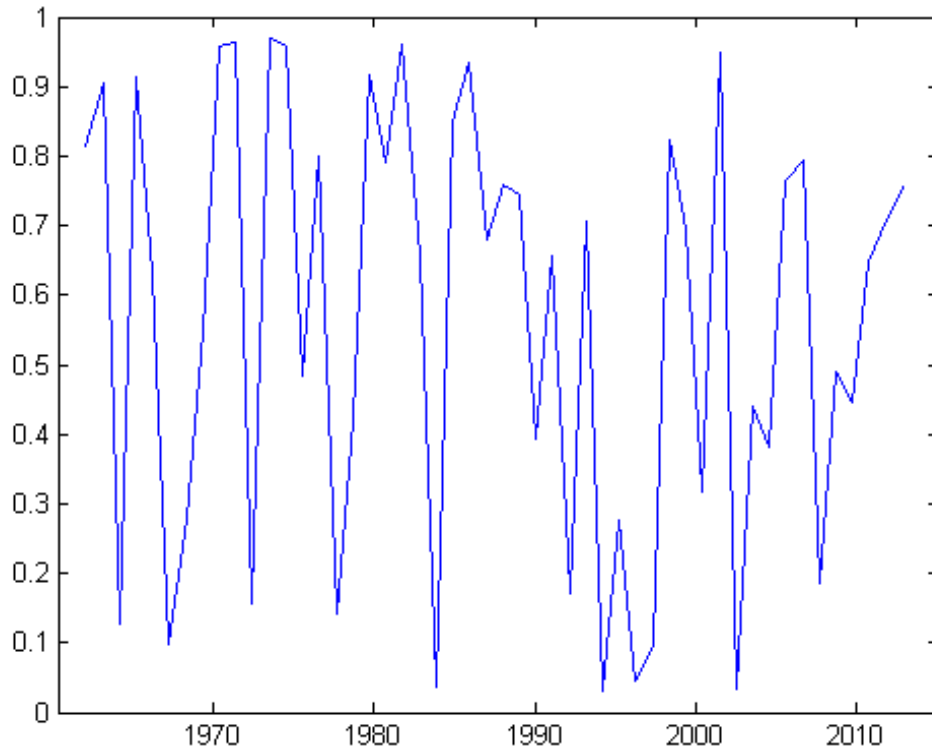

Add Month Labels to Plot and Preserve Number of Ticks

Select a starting date.

```
startDate = datenum('01-01-2009');
```

Select an ending date.

```
endDate = datenum('12-31-2009');
```

Create a variable, `xdata`, that corresponds to the number of months between the start and end dates.

```
xData = linspace(startDate,endDate,12);
```

Plot random data.

```
figure  
plot(xData,rand(1,12))
```

datetick

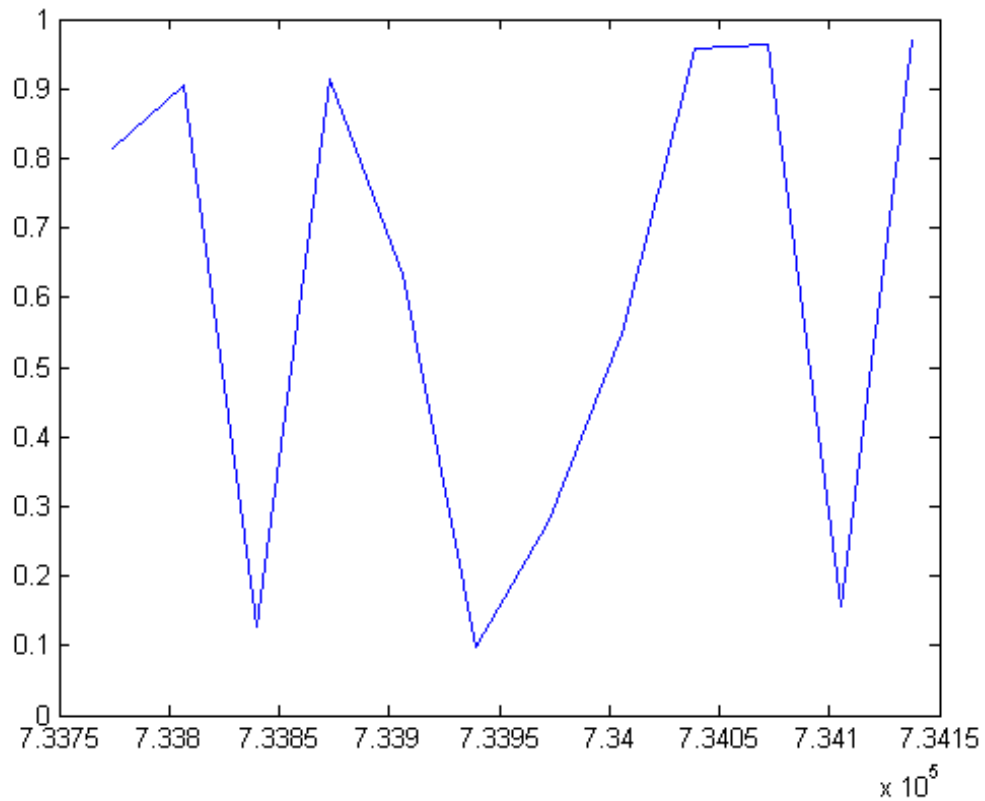

Set the number of XTicks to the number of points in xData.

```
set(gca, 'XTick', xData)
```

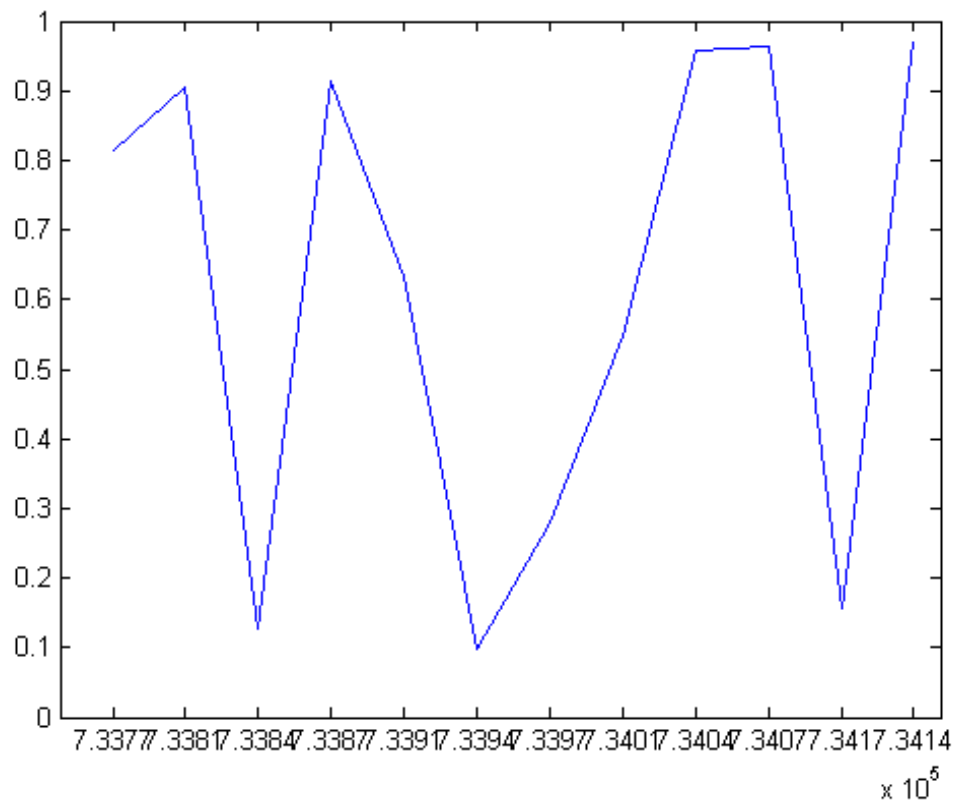
Label the *x*-axis with month names, preserving the total number of ticks by using the 'keepticks' option.

```
datetick('x','mmm','keepticks')
```

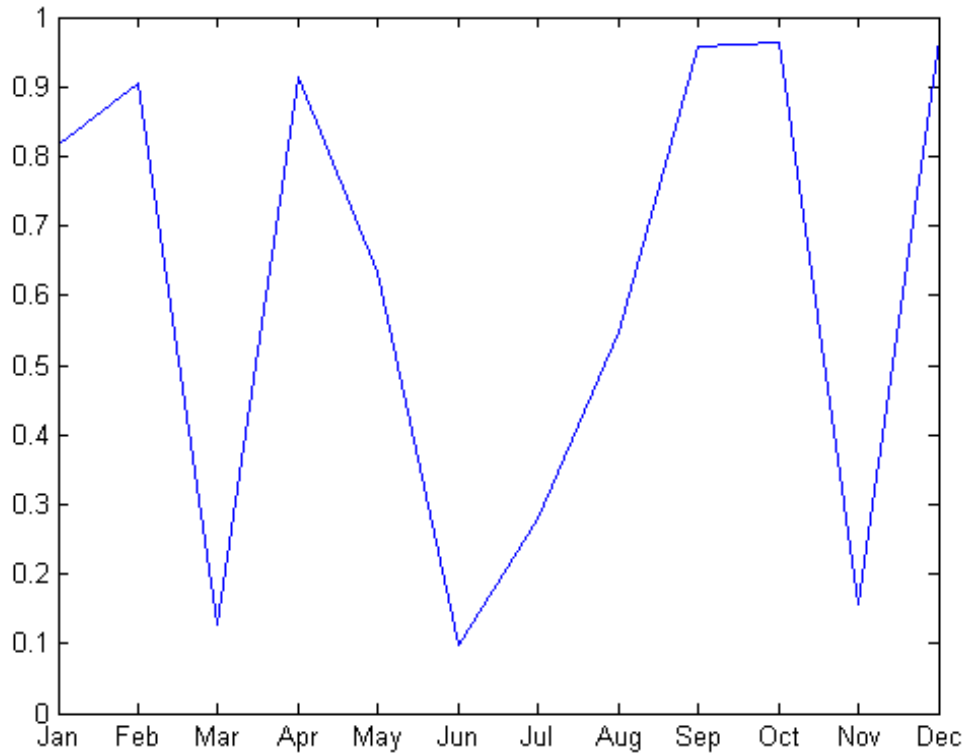

Create Multiple Plots Within Figure and Label Axis with Month Names

Select a starting date and an ending date.

```
startDate = datenum('01-01-2009');  
endDate = datenum('12-31-2009');
```

Create a variable, `xdata`, that corresponds to the number of months between the start and end dates.

```
xData = linspace(startDate,endDate,12);
```

Plot random data.

```
figure  
s(1)=subplot(2,1,1);  
plot(xData,rand(1,12))  
s(2) = subplot(2,1,2);  
plot(xData,rand(1,12))
```

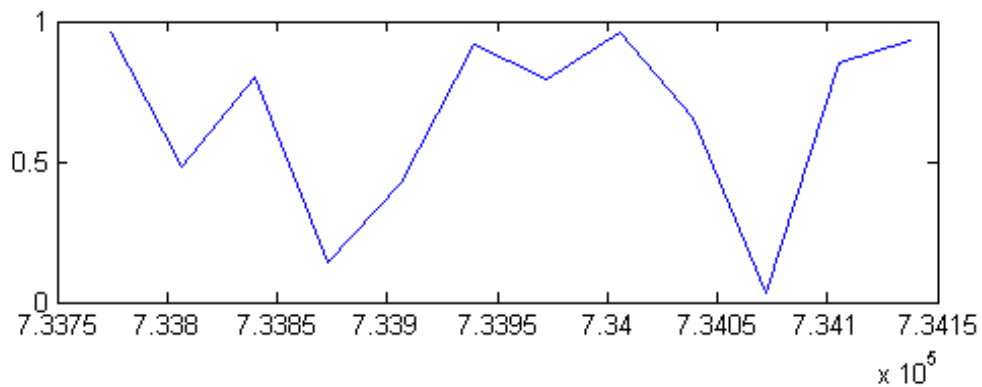
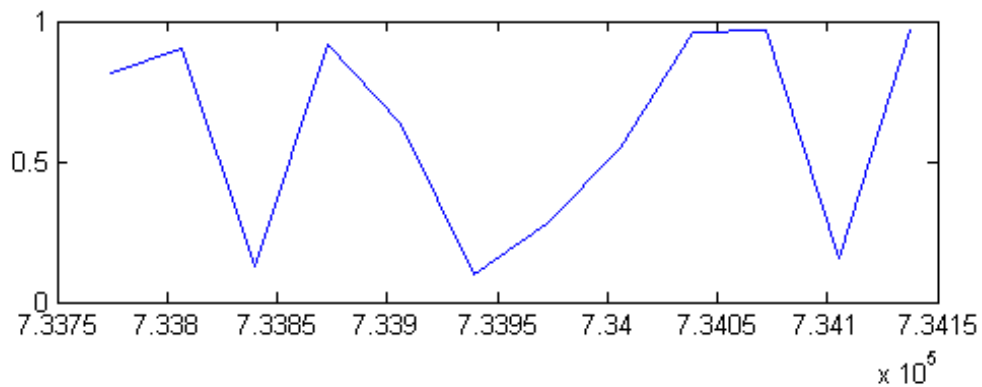

datetick

Set the number of `XTicks` to the number of points in `xData`. Label the `x`-axis of each subplot with month names, referring to each subplot using its axes handle. Preserve the total number of ticks by using the `'keepticks'` option.

```
set(s,'XTick',xData)
for i = 1:2
    datetick(s(i),'x','mmm','keepticks')
end
```

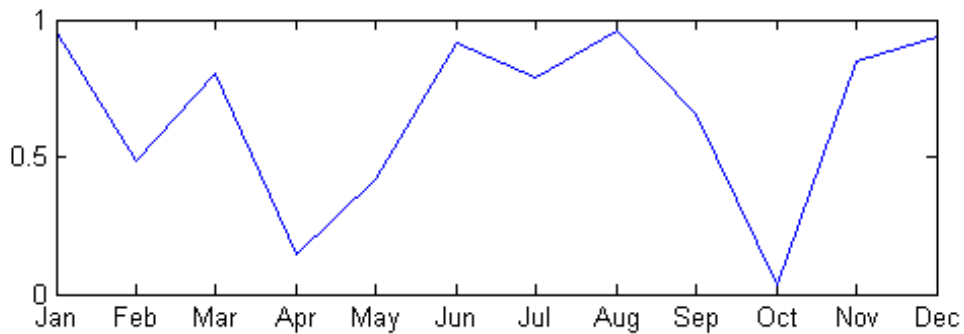
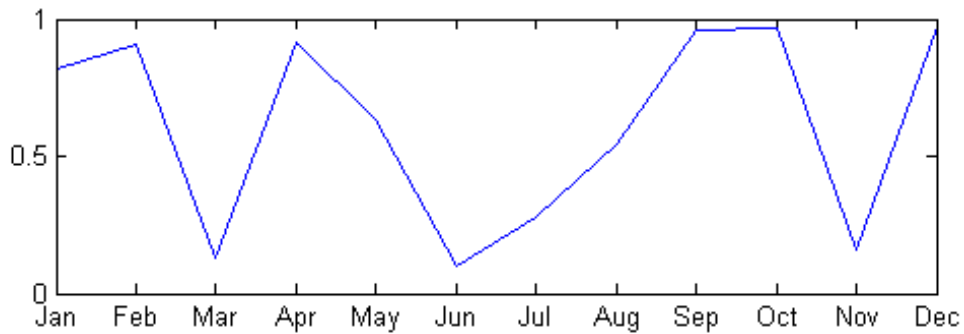

Algorithms

`datetick` calls the `datestr` function to convert date numbers to date strings.

Tips

- To change the tick spacing and locations, set the appropriate axes property (i.e., `XTick`, `YTick`, or `ZTick`) before calling `datetick`.
- Calling `datetick` sets the `TickMode` of the specified axis to `'manual'`. This means that after zooming, panning or otherwise changing axis limits, you should call `datetick` again to update the ticks and labels.

See Also

`XTick` | `YTick` | `ZTick` | `datenum` | `datestr`

datevec

Purpose Convert date and time to vector of components

Syntax `DateVector = datevec(DateNumber)`

`DateVector = datevec(DateString)`

`DateVector = datevec(DateString,formatIn)`

`DateVector = datevec(DateString,PivotYear)`

`DateVector = datevec(DateString,formatIn,PivotYear)`

`[Y, M, D, H, MN, S] = datevec(___)`

Description

`DateVector = datevec(DateNumber)` converts one or more date numbers to date vectors. `datevec` returns an *m*-by-6 matrix containing *m* date vectors, where *m* is the total number of date numbers in `DateNumber`.

`DateVector = datevec(DateString)` converts date strings to date vectors. If the date string format is known, use `formatIn`. Syntaxes without `formatIn` are significantly slower than those that include it.

`DateVector = datevec(DateString,formatIn)` uses `formatIn` to interpret each date string.

`DateVector = datevec(DateString,PivotYear)` uses `PivotYear` to interpret date strings that specify the year as two characters. If the date string format is known, use `formatIn`. Syntaxes without `formatIn` are significantly slower than those that include it.

`DateVector = datevec(DateString,formatIn,PivotYear)` uses `formatIn` to interpret each date string, and `PivotYear` to interpret date strings that specify the year as two characters. You can specify `formatIn` and `PivotYear` in either order.

[Y, M, D, H, MN, S] = datevec(___) returns the components of the date vector as individual variables Y, M, D, H, MN, and S (year, month, day, hour, minutes and seconds). datevec returns milliseconds as a fractional part of the seconds (S) output.

Input Arguments

DateNumber - Serial date number

scalar | vector | multidimensional array

Serial date number, specified as a scalar, vector, or multidimensional array of positive double-precision numbers.

Example: 731878

Data Types

double

DateString - Date strings

string | character array | 1-D cell array of strings

Date strings, specified as a character array where each row corresponds to one date string, or as a one dimensional cell array of strings. All of the date strings must have the same format.

Example: '24 Oct-2003 12:45:07'

Example: ['19-Sep-2013'; '20-Sep-2013'; '21-Sep-2013']

Example: {'15-Oct-2010' '20-Nov-2012'}

If the date string format is known, you should also specify formatIn. If you do not specify formatIn, DateString must be in one of the following formats.

Date String Format	Example
'dd-mmm-yyyy HH:MM:SS'	01-Mar-2000 15:45:17
'dd-mmm-yyyy'	01-Mar-2000
'mm/dd/yyyy'	03/01/2000
'mm/dd/yy'	03/01/00

Date String Format	Example
'mm/dd'	03/01
'mmm.dd,yyyy HH:MM:SS'	Mar.01,2000 15:45:17
'mmm.dd,yyyy'	Mar.01,2000
'yyyy-mm-dd HH:MM:SS'	2000-03-01 15:45:17
'yyyy-mm-dd'	2000-03-01
'yyyy/mm/dd'	2000/03/01
'HH:MM:SS'	15:45:17
'HH:MM:SS PM'	3:45:17 PM
'HH:MM'	15:45
'HH:MM PM'	3:45 PM

Certain date string formats might not contain enough information to convert the date string. In those cases, hours, minutes, and seconds default to 0, days default to 1, months default to January, and years default to the current year. MATLAB considers two-character date string years (e.g., '79') to fall within the 100-year range centered around the current year.

When you do not specify `formatIn`, note the following:

- For the formats that specify the month as two digits (mm), the month value must not be greater than 12.
- However, for the format 'mm/dd/yy', if the first entry in the date string is greater than 12 and the second entry is less than or equal to 12, MATLAB considers the date string to be in 'yy/mm/dd' format.

formatIn - Format of the input date string

string

Format of the input date string, specified as a string of symbolic identifiers.

The following table shows symbolic identifiers you can use to construct the `formatIn` string. You can include characters such as a hyphen, space, or colon to separate the fields.

Symbolic Identifier	Description	Example
yyyy	Year in full	1990, 2002
yy	Year in two digits	90, 02
QQ	Quarter year using letter Q and one digit	Q1
mmmm	Month using full name	March, December
mmm	Month using first three letters	Mar, Dec
mm	Month in two digits	03, 12
m	Month using capitalized first letter	M, D
dddd	Day using full name	Monday, Tuesday
ddd	Day using first three letters	Mon, Tue
dd	Day in two digits	05, 20
d	Day using capitalized first letter	M, T
HH	Hour in two digits (no leading zeros when symbolic identifier AM or PM is used)	05, 5 AM
MM	Minute in two digits	12, 02
SS	Second in two digits	07, 59

Symbolic Identifier	Description	Example
FFF	Millisecond in three digits	057
AM or PM	AM or PM inserted in date string	3:45:02 PM

The formatIn string must follow these guidelines:

- You cannot specify any field more than once. For example, you cannot use 'yy-mmm-dd-m' because it has two month identifiers. The one exception to this is that you can combine one instance of dd with one instance of any of the other day identifiers. For example, 'dddd mmm dd yyyy' is a valid input.
- When you use AM or PM, the HH field is also required.
- datevec does not accept formats that include 'QQ'

PivotYear - Start year of 100-year date range

present minus 50 years (default) | integer

Start year of the 100-year date range in which a two-character year resides, specified as an integer. Use a pivot year to interpret date strings that specify the year as two characters.

If formatIn contains the time of day, the pivot year is computed from the current time of the current day, month, and year. Otherwise it is computed from midnight of the current day, month, and year.

Example: 2000

Data Types

double

Output Arguments

DateVector - Date vectors

vector | matrix

Date vectors, returned as an m-by-6 matrix, where each row corresponds to one date vector, and m is the total number of input date numbers or date strings.

[Y, M, D, H, MN, S] - Components of the date vector

scalar

Components of the date vector (year, month, day, hour, minute, and second), returned as individual scalar variables. Milliseconds are a fractional part of the seconds output.

Examples**Convert Date Number to Date Vector**

```
format short g
```

```
n = 733779.651;  
datevec(n)
```

```
ans =
```

```
      2009           1           6           15           37
```

Convert Date String to Date Vector

```
DateString = '28.03.2005';  
formatIn = 'dd.mm.yyyy';  
datevec(DateString,formatIn)
```

```
ans =
```

```
      2005           3           28           0           0
```

datevec returns a date vector for the date string with the format 'dd.mm.yyyy'.

Convert Multiple Date Strings to Date Vectors

Pass multiple date strings in a cell array. All input date strings must use the same format.

```
DateString = {'09/16/2007';'05/14/1996';'11/29/2010'};  
formatIn = 'mm/dd/yyyy';  
datevec(DateString,formatIn)
```

```
ans =
```

```
    2007         9        16         0         0         0  
    1996         5        14         0         0         0  
    2010        11        29         0         0         0
```

Convert Date with Milliseconds to Date Vector

```
datevec('11:21:02.647','HH:MM:SS.FFF')
```

```
ans =
```

```
1.0e+03 *  
    2.0140    0.0010    0.0010    0.0110    0.0210    0.0026
```

In the output date vector, milliseconds are a fractional part of the seconds field. The date string '11:21:02.647' does not contain enough information to convert to a full date vector. The days default to 1, months default to January, and years default to the current year.

Convert Date String to Date Vector Using Pivot Year

Convert a date string to a date vector using the default pivot year.

```
DateString = '12-jun-17';  
formatIn = 'dd-mmm-yy';  
DateVector = datevec(DateString,formatIn)
```

```
DateVector =  
  
          2017          6          12          0          0
```

Convert the same date string to a date vector using 1800 as the pivot year.

```
DateVector = datevec(DateString,formatIn,1800)
```

```
DateVector =  
  
          1817          6          12          0          0
```

Assign Elements of Returned Date Vector

Convert a date string to a date vector and return the components of the date vector.

```
[y, m, d, h, mn, s] = datevec('01.02.12','dd.mm.yy')
```

```
y =  
  
          2012
```

```
m =  
  
          2
```

datevec

d =

1

h =

0

mn =

0

s =

0

Limitations

- When computing date vectors, MATLAB sets month values less than 1 to 1. Day values, D, less than 1 are set to the last day of the previous month minus $|D|$. However, if $0 \leq \text{DateNumber} < 1$, then `datevec(DateNumber)` returns a date vector of the form `[0 0 0 H MN S]`, where H, MN, and S are hours, minutes, and seconds, respectively.

Tips

- The vectorized calling syntax can offer significant performance improvement for large arrays.

See Also

`datenum` | `datestr`

Concepts

- “Represent Dates and Times in MATLAB”
- “Carryover in Date Vectors and Strings”

Purpose Clear breakpoints

Syntax

```
dbclear all
dbclear in file ...
dbclear in file ... -completenames
dbclear if error ...
dbclear if warning ...
dbclear if naninf
dbclear if infnan
```

Description `dbclear all` removes all breakpoints in all MATLAB code files, as well as breakpoints set for errors, caught errors, caught error identifiers, warnings, warning identifiers, and `naninf/infnan`.

`dbclear in file ...` and `dbclear in file ... -completenames` formats are listed here:

Format	Action
<code>dbclear in file</code>	Removes all breakpoints in <code>file</code> . <code>file</code> must be the name of a MATLAB program file, and can include a MATLAB partial path.
<code>dbclear in file -completenames</code>	If the command includes the <code>-completenames</code> option, then <code>file</code> need not be on the path, as long as it is a fully qualified file name. (On Microsoft Windows platforms, this is a file name that begins with <code>\\</code> or with a drive letter followed by a colon. On UNIX platforms, this is a file name that begins with <code>/</code> or <code>~</code> .) <code>file</code> can include a <code>></code> to specify the path to a particular local function or to a nested function within a code file.
<code>dbclear in file at lineno</code>	Removes the breakpoint set at line number <code>lineno</code> in <code>file</code> .
<code>dbclear in file at lineno@</code>	Removes the breakpoint set in the anonymous function at line number <code>lineno</code> in <code>file</code> .

dbclear

Format	Action
<code>dbclear in file at lineno@n</code>	Removes the breakpoint set in the nth anonymous function at line number <code>lineno</code> in <code>file</code> .
<code>dbclear in file at locfun</code>	Removes all breakpoints in local function <code>locfun</code> in <code>file</code> .

`dbclear if error ...` formats are listed here:

Format	Action
<code>dbclear if error</code>	Removes the breakpoints set using the <code>dbstop if error</code> and <code>dbstop if error</code> identifier statements.
<code>dbclear if error identifier</code>	Removes the breakpoint set using <code>dbstop if error</code> identifier for the specified identifier. Running this produces an error if <code>dbstop if error</code> or <code>dbstop if error all</code> is set.
<code>dbclear if caught error</code>	Removes the breakpoints set using the <code>dbstop if caught error</code> and <code>dbstop if caught error</code> identifier statements.
<code>dbclear if caught error identifier</code>	Removes the breakpoints set using the <code>dbstop if caught error</code> identifier statement for the specified identifier. Running this produces an error if <code>dbstop if caught error</code> or <code>dbstop if caught error all</code> is set.

`dbclear if warning ...` formats are listed here:

<code>dbclear if warning</code>	Removes the breakpoints set using the <code>dbstop if warning</code> and <code>dbstop if warning</code> identifier statements.
<code>dbclear if warning identifier</code>	Removes the breakpoint set using <code>dbstop if warning</code> identifier for the specified identifier. Running this produces an error if <code>dbstop if warning</code> or <code>dbstop if warning all</code> is set.

`dbclear if naninf` removes the breakpoint set by `dbstop if naninf` or `dbstop if infnan`.

`dbclear if infnan` removes the breakpoint set by `dbstop if infnan` or `dbstop if naninf`.

Tips

The **at** and **in** keywords are optional.

In the syntax, `file` can be a MATLAB program file, or the path to a function within a file. For example

```
dbclear in foo>myfun
```

clears the breakpoint at the `myfun` function in the file `foo.m`.

See Also

`dbcont` | `dbdown` | `dbquit` | `dbstack` | `dbstatus` | `dbstop` | `dbstep` | `dbtype` | `dbup` | `filemarker`

Related Examples

- “Disable and Clear Breakpoints”

dbcont

Purpose Resume execution

Syntax dbcont

Description dbcont resumes execution of a MATLAB code file from a breakpoint. Execution continues until another breakpoint is encountered, a pause condition is met, an error occurs, or MATLAB software returns to the base workspace prompt.

Note If you want to edit a file as a result of debugging, it is best to first quit debug mode and then edit and save changes to the file. If you edit a file while paused in debug mode, you can get unexpected results when you resume execution of the file and the results might not be reliable.

See Also dbclear | dbdown | dbquit | dbstack | dbstatus | dbstop | dbstep | dbtype | dbup

Related Examples

- “Step Through a File”

Purpose	Reverse workspace shift performed by <code>dbup</code> , while in debug mode
Syntax	<code>dbdown</code>
Description	<p><code>dbdown</code> changes the current workspace context to the workspace of the called MATLAB code file when a breakpoint is encountered. You must have issued the <code>dbup</code> function at least once before you issue this function. <code>dbdown</code> is the opposite of <code>dbup</code>.</p> <p>Multiple <code>dbdown</code> functions change the workspace context to each successively executed MATLAB code file on the stack until the current workspace context is the current breakpoint. It is not necessary, however, to move back to the current breakpoint to continue execution or to step to the next line.</p>
See Also	<code>dbcont</code> <code>dbclear</code> <code>dbquit</code> <code>dbstack</code> <code>dbstatus</code> <code>dbstop</code> <code>dbstep</code> <code>dbtype</code> <code>dbup</code>
Related Examples	<ul style="list-style-type: none">• “Debugging Process and Features”

dblquad

Purpose

Numerically evaluate double integral over rectangle

dblquad will be removed in a future release. Use `integral2` instead.

Syntax

```
q = dblquad(fun,xmin,xmax,ymin,ymax)
q = dblquad(fun,xmin,xmax,ymin,ymax,tol)
q = dblquad(fun,xmin,xmax,ymin,ymax,tol,method)
```

Description

`q = dblquad(fun,xmin,xmax,ymin,ymax)` calls the `quad` function to evaluate the double integral $\text{fun}(x,y)$ over the rectangle $x_{\min} \leq x \leq x_{\max}$, $y_{\min} \leq y \leq y_{\max}$. The input argument, `fun`, is a function handle that accepts a vector `x`, a scalar `y`, and returns a vector of integrand values.

“Parameterizing Functions” explains how to provide additional parameters to the function `fun`, if necessary.

`q = dblquad(fun,xmin,xmax,ymin,ymax,tol)` uses a tolerance `tol` instead of the default, which is `1.0e-6`.

`q = dblquad(fun,xmin,xmax,ymin,ymax,tol,method)` uses the quadrature function specified as `method`, instead of the default `quad`. Valid values for `method` are `@quad1` or the function handle of a user-defined quadrature method that has the same calling sequence as `quad` and `quad1`.

Examples

Pass function handle `@integrnd` to `dblquad`:

```
Q = dblquad(@integrnd,pi,2*pi,0,pi);
```

where the function `integrnd.m` is:

```
function z = integrnd(x, y)
z = y*sin(x)+x*cos(y);
```

Pass anonymous function handle `F` to `dblquad`:

```
F = @(x,y)y*sin(x)+x*cos(y);
Q = dblquad(F,pi,2*pi,0,pi);
```

The `integrnd` function integrates $y \sin(x) + x \cos(y)$ over the square $\pi \leq x \leq 2\pi$, $0 \leq y \leq \pi$. Note that the integrand can be evaluated with a vector x and a scalar y .

Nonsquare regions can be handled by setting the integrand to zero outside of the region. For example, the volume of a hemisphere is:

```
dblquad(@(x,y) sqrt(max(1-(x.^2+y.^2),0)), -1, 1, -1, 1)
```

or

```
dblquad(@(x,y) sqrt(1-(x.^2+y.^2)).*(x.^2+y.^2<=1), -1, 1, -1, 1)
```

See Also

`quad2d` | `quad` | `quadgk` | `quad1` | `triplequad` | `function_handle` |
`integral` | `integral2` | `integral3`

How To

- “Anonymous Functions”

dbmex

Purpose Enable MEX-file debugging (on UNIX platforms)

Syntax
dbmex **on**
dbmex **off**
dbmex **stop**

Description dbmex **on** enables MEX-file debugging for UNIX platforms.

To use this option, first start the MATLAB software from a debugger by typing `matlab -Ddebugger`, where `debugger` is the name of the debugger program. You must invoke `dbmex on` before calling your MEX-file. If you have already loaded the MEX-file, remove it from memory using the `clear` function.

dbmex **off** disables MEX-file debugging.

dbmex **stop** returns to the debugger prompt.

Tips For more information about debugging MEX-files, see “Debug C/C++ Language MEX-Files”.

See Also `dbclear` | `dbcont` | `dbdown` | `dbquit` | `dbstack` | `dbstatus` | `dbstep` | `dbstop` | `dbtype` | `dbup`

Purpose Quit debug mode

Syntax dbquit
dbquit('all')
dbquit all

Description dbquit terminates debug mode. The Command Window then displays the standard prompt (>>). The file being processed is *not* completed and no results are returned. All breakpoints remain in effect, unless your file contains (and MATLAB has processed) one or more of the following commands: clear all, clear function, clear classes.

If you debug file1 and step into file2, running dbquit terminates debugging for both files. However, if you debug file3 and also debug file4, running dbquit terminates debugging for file4, but file3 remains in debug mode until you run dbquit again.

dbquit('all') or the command form, dbquit all, ends debugging for all files at once.

Examples This example illustrates the use of dbquit relative to dbquit('all'). Set breakpoints in and run file1 and file2:

```
>> dbstop in file1
>> dbstop in file2
>> file1
K>> file2
K>> dbstack
```

MATLAB software returns

```
K>> dbstack
   In file1 at 11
   In file2 at 22
```

If you use the dbquit syntax

```
K>> dbquit
```

dbquit

MATLAB ends debugging for `file2` but `file1` is still in debug mode as shown here

```
K>> dbstack
      in file1 at 11
```

Run `dbquit` again to exit debug mode for `file1`.

Alternatively, `dbquit('all')` ends debugging for both files at once:

```
K>> dbstack
      In file1 at 11
      In file2 at 22
dbquit('all')
dbstack
```

returns no result.

See Also

`clear` | `dbcont` | `dbclear` | `dbdown` | `dbstack` | `dbstatus` | `dbstop` | `dbstep` | `dbtype` | `dbup`

Related Examples

- “Correct Problems and End Debugging”

Purpose Function call stack

Syntax

```
dbstack
dbstack(n)
dbstack(' -completenames' )
[ST,I] = dbstack(...)
```

Description dbstack displays the line numbers and file names of the function calls that led to the current breakpoint, listed in the order in which they were executed. The display lists the line number of the most recently executed function call (at which the current breakpoint occurred) first, followed by its calling function, which is followed by its calling function, and so on. This continues until the topmost MATLAB function is reached. Each line number is a hyperlink you can click to go directly to that line in the Editor. The notation `functionname>localfunctionname` is used to describe the location of the local function.

dbstack(n) omits the first n frames from the display. This is useful when issuing a dbstack from within an error handler, for example.

dbstack(' -completenames') outputs the “complete name“ (the absolute file name and the entire sequence of functions that nests the function in the stack frame) of each function in the stack.

Either none, one, or both n and ' -completenames ' can appear. If both appear, the order is irrelevant.

[ST,I] = dbstack(...) returns the stack trace information in an m-by-1 structure, ST, with the fields:

file	The file in which the function appears. This field is the empty string if there is no file.
name	Function name within the file.
line	Function line number.

The current workspace index is returned in I.

If you step past the end of a file, `dbstack` returns a negative line number value to identify that special case. For example, if the last line to be executed is line 15, then the `dbstack` line number is 15 before you execute that line and -15 afterwards.

Tips

In addition to using `dbstack` while debugging, you can also use `dbstack` within a MATLAB code file outside the context of debugging. In this case, to get and analyze information about the current file stack. For example, to get the name of the calling file, use `dbstack` with an output argument within the file being called. For example:

```
st=dbstack;
```

Examples

This example shows the information returned when you issue `dbstack` while debugging a MATLAB code file:

```
dbstack
```

```
In /usr/local/matlab/toolbox/matlab/cond.m at line 13  
In test1.m at line 2  
In test.m at line 3
```

This example shows the information returned when you issue `dbstack` while debugging `lengthofline.m` to get the complete name of the file, the function name, and line number in which the function appears:

```
[ST,I] = dbstack('-completenames')  
ST =  
    file: 'I:\MATLABfiles\mymfiles\lengthofline.m'  
    name: 'lengthofline'  
    line: 28  
I =  
    1
```

See Also

`dbcont` | `dbclear` | `dbdown` | `dbquit` | `dbstatus` | `dbstop` | `dbstep` | `dbtype` | `dbup` | `evalin` | `mfilename` | `whos`

**Related
Examples**

- “Examine Values”

dbstatus

Purpose List all breakpoints

Syntax

```
dbstatus
dbstatus file
dbstatus('-completenames')
s = dbstatus(...)
```

Description `dbstatus` lists all the breakpoints in effect including errors, caught errors, warnings, and `naninfs`.

`dbstatus file` displays a list of the line numbers for which breakpoints are set in the specified file, where `file` is a MATLAB code file function name or a MATLAB relative partial path. Each line number is a hyperlink you can click to go directly to that line in the Editor.

`dbstatus('-completenames')` displays, for each breakpoint, the absolute file name and the sequence of functions that nest the function containing the breakpoint.

`s = dbstatus(...)` returns breakpoint information in an `m`-by-1 structure with the fields listed in the following table. Use this syntax to save breakpoint status and restore it at a later time using `dbstop(s)`—see `dbstop` for an example.

<code>name</code>	Function name.
<code>file</code>	Full path for file containing breakpoints.
<code>line</code>	Vector of breakpoint line numbers.
<code>anonymous</code>	Vector of integers representing the anonymous functions in the <code>line</code> field. For example, 2 means the second anonymous function in that line. A value of 0 means the breakpoint is at the start of the line, not in an anonymous function.
<code>expression</code>	Cell vector of breakpoint conditional expression strings corresponding to lines in the <code>line</code> field.

cond	Condition string ('error', 'caught error', 'warning', or 'naninf').
identifier	When cond is 'error', 'caught error', or 'warning', a cell vector of MATLAB message identifier strings for which the particular cond state is set.

Use `dbstatus class/function`, `dbstatus private/function`, or `dbstatus class/private/function` to determine the status for methods, private functions, or private methods (for a class named `class`).

In all forms you can further qualify the function name with a local function name, as in `dbstatus function>localfunction`.

Tips

In the syntax, `file` can be a file, or the path to a function within a file. For example

```
Breakpoint for foo>myfun is on line 9
```

means there is a breakpoint at the `myfun` local function, which is line 9 in the file `foo.m`.

See Also

`dbclear` | `dbcont` | `dbdown` | `dbquit` | `dbstack` | `dbstop` | `dbstep` | `dbtype` | `dbup` | `error` | `warning`

dbstep

Purpose Execute one or more lines from current breakpoint

Syntax
dbstep
dbstep *nlines*
dbstep **in**
dbstep **out**

Description This function allows you to debug a MATLAB code file by following its execution from the current breakpoint. At a breakpoint, the `dbstep` function steps through execution of the current file one line at a time or at the rate specified by *nlines*.

`dbstep` executes the next executable line of the current file. `dbstep` steps over the current line, skipping any breakpoints set in functions called by that line.

`dbstep nlines` executes the specified number of executable lines.

`dbstep in` steps to the next executable line. If that line contains a call to another MATLAB code file function, execution will step to the first executable line of the called function. If there is no call to a MATLAB code file on that line, `dbstep in` is the same as `dbstep`.

`dbstep out` runs the rest of the function and stops just after leaving the function.

For all forms, MATLAB software also stops execution at any breakpoint it encounters.

Note If you want to edit a file as a result of debugging, it is best to first quit debug mode and then edit and save changes to the file. If you edit a file while paused in debug mode, you can get unexpected results when you resume execution of the file and the results might not be reliable.

See Also `dbclear` | `dbcont` | `dbdown` | `dbquit` | `dbstack` | `dbstatus` | `dbstop` | `dbtype` | `dbup`

**Related
Examples**

- “Step Through a File”

dbstop

Purpose

Set breakpoints for debugging

Syntax

```
dbstop in file
dbstop in file at location
dbstop in file if expression
dbstop in file at location if expression
dbstop if condition
dbstop(s)
```

Description

`dbstop in file` sets a breakpoint at the first executable line in `file`. When you run `file`, MATLAB enters debug mode and pauses execution at the first executable line.

`dbstop in file at location` sets a breakpoint at the specified location. MATLAB execution pauses immediately before that location, unless the location is an anonymous function. If the location is an anonymous function, then execution pauses just after the breakpoint.

`dbstop in file if expression` sets a breakpoint at the first executable line of the file. Execution pauses only if `expression` evaluates to 1 (true).

`dbstop in file at location if expression` sets a breakpoint at the specified location. Execution pauses at or just before that location only if the `expression` evaluates to true.

`dbstop if condition` pauses execution at the line that meets the specified condition.

`dbstop(s)` restores breakpoints you previously saved to `s`. The files containing the saved breakpoints must be on the search path or in the current folder. MATLAB assigns breakpoints by line number; therefore, the lines in the file must be the same as when you saved the breakpoints, or the results are unpredictable.

Tips

- Use `dbcont` or `dbstep` to resume execution after a breakpoint pauses execution. Use `dbquit` to exit debug mode.

- If you debug a file that MATLAB uses when running and debugging files, and that file is not a MATLAB code file, then some debugging features do not operate as expected. For instance, typing `help functionname` at the debug (`K>>`) prompt will not return help.
- MATLAB can become unresponsive when it stops at a breakpoint while displaying a modal dialog box or figure created by your program. Use **Ctrl+C** to exit debug mode and return to the MATLAB prompt (`>>`).
- If MATLAB pauses and displays a hyperlinked line number in the Command Window, click the hyperlink, The file opens in the Editor at the line where MATLAB paused execution. For an example of such a link, see the image in “Stop at File That Is Not a MATLAB Code File” on page 1-1596
- You can set breakpoints only at executable lines in saved files that are in the current folder or in folders on the search path.
- `dbstop if warning` has no effect when you disable warnings using `warning off all`. Similarly, `dbstop if warning identifier` has no effect when you disable warnings for the specified message identifier. See `warning` for more information about `off`, `all`, and `warning off identifier`

Input Arguments

file

File specification, typically for a MATLAB function, specified as a string. The file specification can include a partial path, but must be in a folder on the search path, or in the current folder.

If the command includes the `-completenames` option, then the file need not be on the search path, as long as the file specification is a “fully qualified name” on page 1-1593. In addition, `filespec` can include a filemarker (`>`) to specify the path to a particular local function or to a nested function within the file.

If `file` is not a MATLAB code file (for instance, it is a built-in or MDL-file), then MATLAB issues a warning. MATLAB cannot stop *in* the file, so it pauses before executing the file.

location

Location in `file` where you want to set a breakpoint, specified as one of the following:

- `lineno`

Line number in `file` specified as a string. The default is 1.

- `lineno@n`

`n`th anonymous function on line number, `lineno`, specified as a string. The default value of `n` is 1.

- `subfun`

Name of a local function in `file`, specified as a string.

expression

Code that evaluates (as if by `eval`) to a scalar logical value of 1 or 0, (true or false, respectively).

condition

Condition that causes execution to pause when that condition evaluates to true. Specify `condition` as one of the following:

- `error`— Run-time error that occurs outside a `try/catch` block. You cannot resume execution after an uncaught run-time error.

If you want execution to pause only if a specific error occurs, specify the message id. For example:

- `dbstop if error` stops execution at the first run-time error that occurs outside a `try/catch` block.
- `dbstop if error MATLAB:ls:InputsMustBeStrings` pauses execution at the first run-time error outside a `try/catch` block that has a message ID of `MATLAB:ls:InputsMustBeStrings`.

- `caught error` — Run-time error that occurs within the `try` portion of a `try/catch` block. If you want execution to stop only if a specific

error occurs, specify the message id. See the error condition for an example of specifying a message id.

- **warning**— Run-time warning occurs. If you want execution to pause only if a specific warning occurs, specify the message id. See the error condition for an example of specifying a message id.

This condition has no effect if you disabled warnings with the `warning off all` command or if you disabled warnings for the specified id. For more information about disabling warnings, see `warning`.

- **naninf and infnan**

The code returns an infinite value (`Inf`) or a value that is not a number (`NaN`) as a result of an operator, function call, or scalar assignment. The `naninf` and `infnan` conditions have identical effects.

s

Breakpoints previously saved to a structure using `s=dbstatus`.

Definitions

fully qualified name

- On Microsoft Windows platforms, a file name that begins with two back slashes (`\\`) or with a drive letter followed by a colon (`:`).
- On UNIX platforms, a file name that begins with a slash (`/`) or a tilde (`~`).

Examples

Stop at First Executable Line

This example shows how to set a breakpoint and pause execution at the first executable line in `buggy.m`.

- 1** Create a file, `buggy.m`, which contains these statements.

```
function z = buggy(x)
n = length(x);
z = (1:n)./x;
```

- 2** Issue the `dbstop` command.

```
dbstop in buggy
```

- 3 Run buggy.

```
buggy(2:5)
```

MATLAB displays the line where it pauses and enters debug mode.

```
2 n = length(x);  
K>>
```

- 4 Advance to the next line in the file.

```
dbstep
```

- 5 Examine the value of n in the Variable Editor.

```
openvar('n')
```

- 6 Quit debug mode.

```
dbquit
```

Stop if Error

This example shows how to set a breakpoint and pause execution if a run-time error occurs.

- 1 Create a file, `buggy.m`, which contains these statements.

```
function z = buggy(x)  
n = length(x);  
z = (1:n)./x;
```

- 2 Issue these statements in the Command Window:

```
dbstop if error  
buggy(magic(3))
```

Because `buggy.m` works on vectors only, the input in step 2 results in a run-time error. MATLAB goes into debug mode, paused at line 3 in `buggy.m`.

```
Error using ./  
Matrix dimensions must agree.
```

```
Error in buggy at 3  
z = (1:n)./x;  
3   z = (1:n)./x;
```

3 Quit debug mode.

```
dbquit
```

Stop if InfNaN

This example shows how to set a breakpoint and pause execution if the code returns a NaN value.

1 Create a file, `buggy.m`, containing these statements.

```
function z = buggy(x)  
n = length(x);  
z = (1:n)./x;
```

2 Issue these commands.

```
dbstop if naninf  
buggy(0:2)
```

If any of the elements of the input, `x`, is zero, a division by zero occurs in `buggy.m`. Therefore, MATLAB returns the following message.

```
NaN/Inf breakpoint hit for buggy on line 3.
```

MATLAB is in debug mode, paused at line 3.

Stop at Function in File

This example shows how to set a breakpoint in the `collatzall` program file at the first executable line in the `collatzplot_new` function.

- 1 Copy `collatzall.m` from the MATLAB examples folder to your current folder.

```
copyfile(fullfile(matlabroot,'help','techdoc','matlab_env',...  
'examples','collatzall.m'),'.','f')
```

- 2 Open `collatzall.m` in the Editor.

```
open collatzall.m
```

- 3 Set the breakpoint.

```
dbstop in collatzall>collatzplot_new
```

Stop at File That Is Not a MATLAB Code File

This example shows how to set a breakpoint at the built-in function `clear` when you run `myfile.m`.

- 1 Create a file, `myfile.m`, in the Editor, containing these statements.

```
function myfile(x)  
n = length(x);  
if n < 10  
    disp('length is less than 10')  
else  
    disp('length is 10 or greater')  
end  
clear  
disp('Value of n is cleared')
```

- 2 Issue these commands to set the breakpoint.

```
x = [1 2 3 4 5 6 7 8 9 10]
```

```
dbstop in clear; myfile(x)
```

MATLAB issues a warning, and pauses before the call to the `clear` function. The warning appears as shown in this image.

```
Warning: MATLAB debugger can only stop in MATLAB code files, and
"m_interpreter>clear" is not a MATLAB code file.
      Instead, the debugger will stop at the point right before
      "m_interpreter>clear" is called.
length is 10 or greater
8      clear
K>> |
```

Restore Saved Breakpoints

This example shows how to save, and then restore, saved breakpoints.

- 1 Copy `collatzall.m` from the MATLAB examples folder to your current folder.

```
copyfile(fullfile(matlabroot,'help','techdoc','matlab_env', ...
    'examples','collatzall.m'),'.','f')
```

- 2 Open `collatzall.m` in the Editor.

```
open collatzall.m
```

- 3 Set breakpoints from the Command Window.

```
dbstop at 12 in collatzall
dbstop if error
```

- 4 Run `dbstatus`.

```
dbstatus
```

MATLAB describes the breakpoints you set.

dbstop

Breakpoint for `collatzall>collatzplot_new` is on line 12.
Stop if error.

- 5 Save the breakpoints to the structure, `s`, and then save `s` to the MAT-file, `myfilebrkpnts`.

```
s=dbstatus('-completenames');  
save myfilebrkpnts s
```

Using `s=dbstatus('-completenames')` saves absolute paths and the breakpoint function nesting sequence.

- 6 Clear all breakpoints.

```
dbclean collatzall
```

- 7 Restore the breakpoints by loading the MAT-file.

```
load myfilebrkpnts  
dbstop(s)
```

The file (or files) containing the breakpoints must be on the search path or in the current folder.

- 8 Verify the breakpoints.

```
dbstatus collatzall
```

See Also

`dbclean` | `dbcont` | `dbdown` | `dbquit` | `dbstack` | `dbstatus` | `dbstep` | `dbtype` | `dbup`

Related Examples

- “Set Breakpoints”

Purpose	List text file with line numbers
Syntax	<code>dbtype filename</code> <code>dbtype filename start:end</code>
Description	<p>The <code>dbtype</code> command is used to list a text file with line numbers, which is helpful when setting breakpoints in a MATLAB code file with <code>dbstop</code>.</p> <p><code>dbtype filename</code> displays the contents of the specified text file, with the line number preceding each line. <code>filename</code> must be the full path name of a file, or a MATLAB relative partial path.</p> <p><code>dbtype filename start:end</code> displays the portion of the file specified by a range of line numbers from <code>start</code> to <code>end</code>.</p> <p>You cannot use <code>dbtype</code> for built-in functions.</p>
Examples	<p>To see only the input and output arguments for a function, that is, the first line of the file, use the syntax</p> <pre>dbtype filename 1</pre> <p>For example,</p> <pre>dbtype addpath 1</pre> <p>returns</p> <pre>1 function oldpath = addpath(varargin)</pre>
See Also	<code>dbclear</code> <code>dbcont</code> <code>dbdown</code> <code>dbquit</code> <code>dbstack</code> <code>dbstatus</code> <code>dbstep</code> <code>dbstop</code> <code>dbup</code>

dbup

Purpose Shift current workspace to workspace of caller, while in debug mode

Syntax dbup

Description This function allows you to examine the calling MATLAB code file to determine what caused the arguments to be passed to the called function.

dbup changes the current workspace context, while the user is in the debug mode, to the workspace of the calling file.

Multiple dbup functions change the workspace context to each previous calling file on the stack until the base workspace context is reached. (It is not necessary, however, to move back to the current breakpoint to continue execution or to step to the next line.)

Tips If you receive an error message such as the following, it means that the parent workspace is under construction so that the value of x is unavailable:

```
??? Reference to a called function result under construction x
```

See Also dbclear | dbcont | dbdown | dbquit | dbstack | dbstatus | dbstep | dbstop | dbtype

Concepts

- “Problems Viewing Variable Values from the Parent Workspace”

Purpose

Solve delay differential equations (DDEs) with constant delays

Syntax

```
sol = dde23(ddefun,lags,history,tspan)
sol = dde23(ddefun,lags,history,tspan,options)
```

Arguments

ddefun

Function handle that evaluates the right side of the differential equations

$y'(t) = f(t, y(t), y(t - \tau_1), \dots, y(t - \tau_k))$. The function must have the form

```
dydt = ddefun(t,y,Z)
```

where t corresponds to the current t , y is a column vector that approximates $y(t)$, and $Z(:, j)$ approximates $y(t - \tau_j)$ for delay $\tau_j = \text{lags}(j)$. The output is a column vector

corresponding to $f(t, y(t), y(t - \tau_1), \dots, y(t - \tau_k))$.

lags

Vector of constant, positive delays τ_1, \dots, τ_k .

history

Specify history in one of three ways:

- A function of t such that $y = \text{history}(t)$ returns the solution $y(t)$ for $t \leq t_0$ as a column vector
- A constant column vector, if $y(t)$ is constant
- The solution `sol` from a previous integration, if this call continues that integration

<code>tspan</code>	Interval of integration from <code>t0=tspan(1)</code> to <code>tf=tspan(end)</code> with <code>t0 < tf</code> .
<code>options</code>	Optional integration argument. A structure you create using the <code>dde23set</code> function. See <code>dde23set</code> for details.

Description

`sol = dde23(ddefun, lags, history, tspan)` integrates the system of DDEs

$$y'(t) = f(t, y(t), y(t - \tau_1), \dots, y(t - \tau_k))$$

on the interval $[t_0, t_f]$, where τ_1, \dots, τ_k are constant, positive delays and t_0, t_f . The input argument, `ddefun`, is a function handle.

“Parameterizing Functions” explains how to provide additional parameters to the function `ddefun`, if necessary.

`dde23` returns the solution as a structure `sol`. Use the auxiliary function `deval` and the output `sol` to evaluate the solution at specific points `tint` in the interval `tspan = [t0, tf]`.

```
yint = deval(sol, tint)
```

The structure `sol` returned by `dde23` has the following fields.

<code>sol.x</code>	Mesh selected by <code>dde23</code>
<code>sol.y</code>	Approximation to $y(x)$ at the mesh points in <code>sol.x</code> .
<code>sol.yp</code>	Approximation to $y'(x)$ at the mesh points in <code>sol.x</code>
<code>sol.solver</code>	Solver name, 'dde23'

`sol = dde23(ddefun, lags, history, tspan, options)` solves as above with default integration properties replaced by values in `options`, an argument created with `dde23set`. See `dde23set` and “Types of DDEs” in the MATLAB documentation for details.

Commonly used options are scalar relative error tolerance 'RelTol' ($1e-3$ by default) and vector of absolute error tolerances 'AbsTol' (all components are $1e-6$ by default).

Use the 'Jumps' option to solve problems with discontinuities in the history or solution. Set this option to a vector that contains the locations of discontinuities in the solution prior to t_0 (the history) or in coefficients of the equations at known values of t after t_0 .

Use the 'Events' option to specify a function that dde23 calls to find where functions $g(t, y(t), y(t - \tau_1), \dots, y(t - \tau_k))$ vanish. This function must be of the form

```
[value, isterminal, direction] = events(t, y, Z)
```

and contain an event function for each event to be tested. For the k th event function in events:

- `value(k)` is the value of the k th event function.
- `isterminal(k) = 1` if you want the integration to terminate at a zero of this event function and 0 otherwise.
- `direction(k) = 0` if you want dde23 to compute all zeros of this event function, +1 if only zeros where the event function increases, and -1 if only zeros where the event function decreases.

If you specify the 'Events' option and events are detected, the output structure `sol` also includes fields:

<code>sol.xe</code>	Row vector of locations of all events, i.e., times when an event function vanished
<code>sol.ye</code>	Matrix whose columns are the solution values corresponding to times in <code>sol.xe</code>
<code>sol.ie</code>	Vector containing indices that specify which event occurred at the corresponding time in <code>sol.xe</code>

Examples

This example solves a DDE on the interval $[0, 5]$ with lags 1 and 0.2. The function `ddex1de` computes the delay differential equations, and `ddex1hist` computes the history for $t \leq 0$.

Note The file, `ddex1.m`, contains the complete code for this example. To see the code in an editor, type `edit ddex1` at the command line. To run it, type `ddex1` at the command line.

```
sol = dde23(@ddex1de,[1, 0.2],@ddex1hist,[0, 5]);
```

This code evaluates the solution at 100 equally spaced points in the interval $[0, 5]$, then plots the result.

```
tint = linspace(0,5);  
yint = deval(sol,tint);  
plot(tint,yint);
```

`ddex1` shows how you can code this problem using local functions. For more examples see `ddex2`.

Algorithms

`dde23` tracks discontinuities and integrates with the explicit Runge-Kutta (2,3) pair and interpolant of `ode23`. It uses iteration to take steps longer than the lags.

References

[1] Shampine, L.F. and S. Thompson, "Solving DDEs in MATLAB," *Applied Numerical Mathematics*, Vol. 37, 2001, pp. 441-458.

[2] Kierzenka, J., L.F. Shampine, and S. Thompson, "Solving Delay Differential Equations with DDE23," available at www.mathworks.com/dde_tutorial.

See Also

`ddesd` | `ddensd` | `ddeget` | `ddeset` | `deval` | `function_handle`

Purpose Extract properties from delay differential equations options structure

Syntax

```
val = ddeget(options,'name')  
val = ddeget(options,'name',default)
```

Description `val = ddeget(options,'name')` extracts the value of the named property from the structure `options`, returning an empty matrix if the property value is not specified in `options`. It is sufficient to type only the leading characters that uniquely identify the property. Case is ignored for property names. `[]` is a valid `options` argument.

`val = ddeget(options,'name',default)` extracts the named property as above, but returns `val = default` if the named property is not specified in `options`. For example,

```
val = ddeget(opts,'RelTol',1e-4);
```

returns `val = 1e-4` if the `RelTol` is not specified in `opts`.

See Also `dde23` | `ddesd` | `ddensd` | `ddeset`

ddensd

Purpose

Solve delay differential equations (DDEs) of neutral type

Syntax

```
sol = ddensd(ddefun,dely,delyp,history,tspan)
sol = ddensd(ddefun,dely,delyp,history,tspan,options)
```

Description

`sol = ddensd(ddefun,dely,delyp,history,tspan)` integrates a system of delay differential equations of neutral type, that has the form

$$y'(t) = f(t, y(t), y(dy_1), \dots, y(dy_p), y'(dyp_1), \dots, y'(dyp_q)) \quad (1-1)$$

where

- t is the independent variable representing time.
- dy_i is any of p solution delays.
- dyp_j is any of q derivative delays.

`sol = ddensd(ddefun,dely,delyp,history,tspan,options)` replaces default integration parameters with those specified in `options`, a structure created with the `ddeSet` function.

Input Arguments

ddefun - Derivative function

function handle

Derivative function, specified as a function handle whose syntax is `yp = ddefun(t,y,ydel,ypdel)`. The arguments for `ddefun` are described in the table below.

ddefun Argument	Description
<code>t</code>	A scalar value representing the current value of time, t .
<code>y</code>	A vector that represents $y(t)$ in Equation 1-1. The size of this vector is n -by-1, where n is the number of equations in the system you want to solve.

ddefun Argument	Description
ydel	A matrix whose columns, <code>ydel(:, i)</code> , represent $y(dy_i)$. The size of this matrix is n-by-p, where n is the number of equations in the system you want to solve, and p is the number of $y(dy)$ terms in Equation 1-1.
ypdel	A matrix whose columns, <code>ypdel(:, j)</code> represent $y'(dyp_j)$. The size of this matrix is n-by-q, where n is the number of equations in the system you want to solve, and q is the number of $y'(dyp)$ terms in Equation 1-1.
yp	The result returned by <code>ddefun</code> . It is an n-by-1 vector whose elements represent the right side of Equation 1-1.

dely - Solution delays

function handle | vector

Solution delays, specified as a function handle, which returns dy_1, \dots, dy_p in Equation 1-1. Alternatively, you can pass constant delays in the form of a vector.

If you specify `dely` as a function handle, the syntax must be `dy = dely(t, y)`. The arguments for this function are described in the table below.

dely Argument	Description
t	A scalar value representing the current value of time, t .
y	A vector that represents $y(t)$ in Equation 1-1. The size of this vector is n-by-1, where n is the number of equations in the system you want to solve.
dy	A vector returned by the dely function whose values are the solution delays, dy_i , in Equation 1-1. The size of this vector is p-by-1, where p is the number of solution delays in the equation. Each element must be less than or equal to t .

If you want to specify constant solution delays having the form $dy_i = t - \tau_i$, then **dely** must be a vector, where $\text{dely}(i) = \tau_i$. Each value in this vector must be greater than or equal to zero.

If dy is not present in the problem, set **dely** to `[]`.

Data Types

function_handle | single | double

delyp - Derivative delays

function_handle | vector

Derivative delays, specified as a function handle, which returns $dy_{p_1}, \dots, dy_{p_q}$ in Equation 1-1. Alternatively, you can pass constant delays in the form of a vector.

If **delyp** is a function handle, its syntax must be `dyp = delyp(t,y)`. The arguments for this function are described in the table below.

delyp Argument	Description
t	A scalar value representing the current value of time, t .
y	A vector that represents $y(t)$ in Equation 1-1. The size of this vector is n-by-1, where n is the number of equations in the system you want to solve.
dyp	A vector returned by the <code>delyp</code> function whose values are the derivative delays, dyp_j , in Equation 1-1. The size of this vector must be q-by-1, where q is the number of solution delays, dyp_j , in the equation. Each element of <code>dyp</code> must be less than t . There is one exception to this restriction: if you are solving an initial value DDE, the value of <code>dyp</code> can equal t at $t = t_0$. For more information, see “Initial Value Neutral Delay Differential Equations” on page 1-1611.

If you want specify constant derivative delays having the form $dyp_j = t - \tau_j$, then `delyp` must be a vector, where `delyp(j) = τ_j` . Each value in this vector must be greater than zero. An exception to this restriction occurs when you solve initial value problems for DDEs of neutral type. In such cases, a value in `delyp` can equal zero at $t = t_0$. See “Initial Value Neutral Delay Differential Equations” on page 1-1611 for more information.

If `dyp` is not present in the problem, set `delyp` to `[]`.

Data Types

function_handle | single | double

history - Solution history

function handle | column vector | structure (sol, from previous integration) | 1-by-2 cell array

Solution history, specified as a function handle, column vector, `sol` structure (from a previous integration), or a cell array. This is the solution at $t \leq t_0$.

- If the history varies with time, specify the solution history as a function handle whose syntax is `y = history(t)`. This function returns an n -by-1 vector that approximates the solution, $y(t)$, for $t \leq t_0$. The length of this vector, n , is the number of equations in the system you want to solve.
- If $y(t)$ is constant, you can specify `history` as an n -by-1 vector of the constant values.
- If you are calling `ddensd` to continue a previous integration to t_0 , you can specify `history` as the output, `sol`, from the previous integration.
- If you are solving an initial value DDE, specify `history` as a cell array, `{y0, yp0}`. The first element, `y0`, is a column vector of initial values, $y(t_0)$. The second element, `yp0`, is a column vector whose elements are the initial derivatives, $y'(t_0)$. These vectors must be consistent, meaning that they satisfy Equation 1-1 at t_0 . See “Initial Value Neutral Delay Differential Equations” on page 1-1611 for more information.

Data Types

`function_handle` | `single` | `double` | `struct` | `cell`

`tspan` - Interval of integration

1-by-2 vector

Interval of integration, specified as the vector `[t0 tf]`. The first element, `t0`, is the initial value of t . The second element, `tf`, is the final value of t . The value of `t0` must be less than `tf`.

Data Types

`single` | `double`

`options` - Optional integration parameters

structure returned by `ddeset`

Optional integration parameters, specified as a structure created and returned by the `ddeset` function. Some commonly used properties are: 'RelTol', 'AbsTol', and 'Events'. See the `ddeset` reference page for more information about specifying options.

Output Arguments

sol - Solution

structure

Solution, returned as a structure containing the following fields.

<code>sol.x</code>	Mesh selected by <code>ddensd</code> .
<code>sol.y</code>	An approximation to $y(t)$ at the mesh points.
<code>sol.yp</code>	An approximation to $y'(t)$ at the mesh points.
<code>sol.solver</code>	A string identifying the solver, 'ddensd'.

You can pass `sol` to the `deval` function to evaluate the solution at specific points. For example, `y = deval(sol, 0.5*(sol.x(1) + sol.x(end)))` evaluates the solution at the midpoint of the interval of integration.

Definitions

Initial Value Neutral Delay Differential Equations

An initial value DDE has $dy_i \geq t_0$ and $dyp_j \geq t_0$, for all i and j . At $t = t_0$, all delayed terms reduce to $y(dy_i) = y(t_0)$ and $y'(dyp_j) = y'(t_0)$:

$$y'(t_0) = f(t_0, y(t_0), y(t_0), \dots, y(t_0), y'(t_0), \dots, y'(t_0)) \tag{1-2}$$

For $t > t_0$, all derivative delays must satisfy $dyp < t$.

When you solve initial value neutral DDEs, you must supply $y'(t_0)$ to `ddensd`. To do this, specify `history` as a cell array `{Y0, YP0}`. Here, `Y0` is the column vector of initial values, $y(t_0)$, and `YP0` is a column vector of initial derivatives, $y'(t_0)$. These vectors must be consistent, meaning that they satisfy Equation 1-2 at t_0 .

Examples

Neutral DDE with Two Delays

Solve the following neutral DDE, presented by Paul, for $0 \leq t \leq \pi$:

$$y'(t) = 1 + y(t) - 2y(t/2)^2 - y'(t - \pi)$$

with history: $y(t) = \cos(t)$ for $t \leq 0$.

Create a new program file in the editor. This file will contain a main function and four local functions.

Define the first-order DDE as a local function.

```
function yp = ddefun(t,y,ydel,ypdel)
    yp = 1 + y - 2*ydel^2 - ypdel;
end
```

Define the solution delay as a local function.

```
function dy = dely(t,y)
    dy = t/2;
end
```

Define the derivative delay as a local function.

```
function dyp = delyp(t,y)
    dyp = t-pi;
end
```

Define the solution history as a local function.

```
function y = history(t)
    y = cos(t);
end
```

Define the interval of integration and solve the DDE using the `ddensd` function. Add this code to the main function.

```
tspan = [0 pi];
sol = ddensd(@ddefun,@dely,@delyp,@history,tspan);
```

Evaluate the solution at 100 equally spaced points between 0 and π .
Add this code to the main function.

```
tn = linspace(0,pi);  
yn = deval(sol,tn);
```

Plot the results. Add this code to the main function.

```
plot(tn,yn);  
xlim([0 pi]);  
ylim([-1.2 1.2]);  
xlabel('time t');  
ylabel('solution y');
```

Run your program to calculate the solution and display the plot.

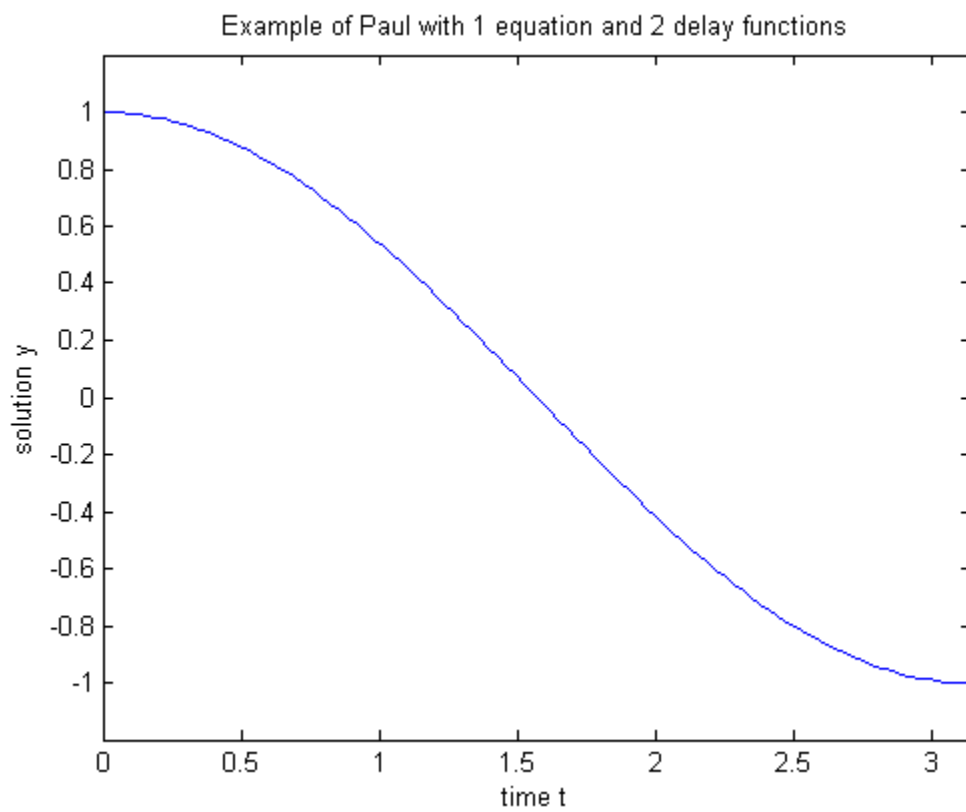

The file, `ddex4.m`, contains the complete code for this example. To see the code in an editor, type `edit ddex4` at the command line.

Algorithms

For information about the algorithm used in this solver, see Shampine [2].

References

- [1] Paul, C.A.H. “A Test Set of Functional Differential Equations.” *Numerical Analysis Reports*. No. 243. Manchester, UK: Math Department, University of Manchester, 1994.
- [2] Shampine, L.F. “Dissipative Approximations to Neutral DDEs.” *Applied Mathematics & Computation*. Vol. 203, Number 2, 2008, pp. 641–648.

See Also

deval | ddeset | ddesd | dde23 | function_handle

ddestd

Purpose Solve delay differential equations (DDEs) with general delays

Syntax
`sol = ddestd(ddefun,delays,history,tspan)`
`sol = ddestd(ddefun,delays,history,tspan,options)`

Arguments

ddefun Function handle that evaluates the right side of the differential equations $y'(t) = f(t,y(t),y(d(1)),\dots,y(d(k)))$. The function must have the form

`dydt = ddefun(t,y,Z)`

where t corresponds to the current t , y is a column vector that approximates $y(t)$, and $Z(:,j)$ approximates $y(d(j))$ for delay $d(j)$ given as component j of `delays(t,y)`. The output is a column vector corresponding to $f(t,y(t),y(d(1)),\dots,y(d(k)))$.

delays Function handle that returns a column vector of delays $d(j)$. The delays can depend on both t and $y(t)$. `ddestd` imposes the requirement that $d(j) \leq t$ by using $\min(d(j),t)$.

If all the delay functions have the form $d(j) = t - \tau_j$, you can set the argument `delays` to a constant vector `delays(j) = τ_j` . With delay functions of this form, `ddestd` is used exactly like `dde23`.

history	Specify history in one of three ways: <ul style="list-style-type: none"> • A function of t such that $y = \text{history}(t)$ returns the solution $y(t)$ for $t \leq t_0$ as a column vector • A constant column vector, if $y(t)$ is constant • The solution <code>sol</code> from a previous integration, if this call continues that integration
tspan	Interval of integration from <code>t0=tspan(1)</code> to <code>tf=tspan(end)</code> with <code>t0 < tf</code> .
options	Optional integration argument. A structure you create using the <code>ddeset</code> function. See <code>ddeset</code> for details.

Description

`sol = ddesd(ddefun,delays,history,tspan)` integrates the system of DDEs

$$y'(t) = f(t, y(t), y(d(1)), \dots, y(d(k)))$$

on the interval $[t_0, t_f]$, where delays $d(j)$ can depend on both t and $y(t)$, and $t_0 < t_f$. Inputs `ddefun` and `delays` are function handles. See the `function_handle` reference page for more information.

“Parameterizing Functions” explains how to provide additional parameters to the functions `ddefun`, `delays`, and `history`, if necessary.

`ddesd` returns the solution as a structure `sol`. Use the auxiliary function `deval` and the output `sol` to evaluate the solution at specific points `tint` in the interval `tspan = [t0,tf]`.

`yint = deval(sol,tint)`

The structure `sol` returned by `ddesd` has the following fields.

<code>sol.x</code>	Mesh selected by <code>ddesd</code>
<code>sol.y</code>	Approximation to $y(x)$ at the mesh points in <code>sol.x</code> .
<code>sol.yp</code>	Approximation to $y'(x)$ at the mesh points in <code>sol.x</code>
<code>sol.solver</code>	Solver name, 'ddesd'

`sol = ddesd(ddefun,delays,history,tspan,options)` solves as above with default integration properties replaced by values in `options`, an argument created with `ddeset`. See `ddeset` and “Types of DDEs” in the MATLAB documentation for details.

Commonly used options are scalar relative error tolerance 'RelTol' ($1e-3$ by default) and vector of absolute error tolerances 'AbsTol' (all components are $1e-6$ by default).

Use the 'Events' option to specify a function that `ddesd` calls to find where functions $g(t,y(t),y(d(1)),\dots,y(d(k)))$ vanish. This function must be of the form

```
[value,isterminal,direction] = events(t,y,Z)
```

and contain an event function for each event to be tested. For the k th event function in `events`:

- `value(k)` is the value of the k th event function.
- `isterminal(k) = 1` if you want the integration to terminate at a zero of this event function and 0 otherwise.
- `direction(k) = 0` if you want `ddesd` to compute all zeros of this event function, +1 if only zeros where the event function increases, and -1 if only zeros where the event function decreases.

If you specify the 'Events' option and events are detected, the output structure `sol` also includes fields:

<code>sol.xe</code>	Row vector of locations of all events, i.e., times when an event function vanished
<code>sol.ye</code>	Matrix whose columns are the solution values corresponding to times in <code>sol.xe</code>
<code>sol.ie</code>	Vector containing indices that specify which event occurred at the corresponding time in <code>sol.xe</code>

Examples

The equation

```
sol = ddesd(@ddex1de,@ddex1delays,@ddex1hist,[0,5]);
```

solves a DDE on the interval $[0,5]$ with delays specified by the function `ddex1delays` and differential equations computed by `ddex1de`. The history is evaluated for $t \leq 0$ by the function `ddex1hist`. The solution is evaluated at 100 equally spaced points in $[0,5]$:

```
tint = linspace(0,5);
yint = deval(sol,tint);
```

and plotted with

```
plot(tint,yint);
```

This problem involves constant delays. The delay function has the form

```
function d = ddex1delays(t,y)
%DDEX1DELAYS Delays for using with DDEX1DE.
d = [ t - 1
      t - 0.2];
```

The problem can also be solved with the syntax corresponding to constant delays

```
delays = [1, 0.2];
sol = ddesd(@ddex1de,delays,@ddex1hist,[0, 5]);
```

or using `dde23`:

ddesd

```
sol = dde23(@ddex1de,delays,@ddex1hist,[0, 5]);
```

For more examples of solving delay differential equations see `ddex2` and `ddex3`.

References

[1] Shampine, L.F., “Solving ODEs and DDEs with Residual Control,” *Applied Numerical Mathematics*, Vol. 52, 2005, pp. 113-127.

See Also

`dde23` | `ddeget` | `ddensd` | `ddeset` | `deval` | `function_handle`

Purpose Create or alter delay differential equations options structure

Syntax

```
options = ddeset('name1',value1,'name2',value2,...)
options = ddeset(olddopts,'name1',value1,...)
options = ddeset(olddopts,newopts)
ddeset
```

Description `options = ddeset('name1',value1,'name2',value2,...)` creates an integrator options structure `options` in which the named properties have the specified values. Any unspecified properties have default values. It is sufficient to type only the leading characters that uniquely identify the property. `ddeset` ignores case for property names.

`options = ddeset(olddopts,'name1',value1,...)` alters an existing options structure `olddopts`. This overwrites any values in `olddopts` that are specified using name/value pairs and returns the modified structure as the output argument.

`options = ddeset(olddopts,newopts)` combines an existing options structure `olddopts` with a new options structure `newopts`. Any values set in `newopts` overwrite the corresponding values in `olddopts`.

`ddeset` with no input arguments displays all property names and their possible values, indicating defaults with braces `{}`.

You can use the function `ddeget` to query the options structure for the value of a specific property.

DDE Properties

The following sections describe the properties that you can set using `ddeset`. There are several categories of properties:

- Error control
- Solver output
- Step size
- Event location
- Discontinuities

Error Control Properties

At each step, the DDE solvers estimate an error e . The `dde23` function estimates the local truncation error, and the other solvers estimate the residual. In either case, this error must be less than or equal to the acceptable error, which is a function of the specified relative tolerance, `RelTol`, and the specified absolute tolerance, `AbsTol`.

$$|e(i)| * \max(\text{RelTol} * \text{abs}(y(i)), \text{AbsTol}(i))$$

For routine problems, the solvers deliver accuracy roughly equivalent to the accuracy you request. They deliver less accuracy for problems integrated over “long” intervals and problems that are moderately unstable. Difficult problems may require tighter tolerances than the default values. For relative accuracy, adjust `RelTol`. For the absolute error tolerance, the scaling of the solution components is important: if $|y|$ is somewhat smaller than `AbsTol`, the solver is not constrained to obtain any correct digits in y . You might have to solve a problem more than once to discover the scale of solution components.

Roughly speaking, this means that you want `RelTol` correct digits in all solution components except those smaller than thresholds `AbsTol(i)`. Even if you are not interested in a component $y(i)$ when it is small, you may have to specify `AbsTol(i)` small enough to get some correct digits in $y(i)$ so that you can accurately compute more interesting components.

The following table describes the error control properties.

DDE Error Control Properties

Property	Value	Description
RelTol	Positive scalar {1e-3}	<p>A relative error tolerance that applies to all components of the solution vector y. It is a measure of the error relative to the size of each solution component. Roughly, it controls the number of correct digits in all solution components except those smaller than thresholds $AbsTol(i)$. The default, 1e-3, corresponds to 0.1% accuracy.</p> <p>The estimated error in each integration step satisfies $e(i) \leq \max(RelTol * abs(y(i)), AbsTol(i))$.</p>
AbsTol	Positive scalar or vector {1e-6}	<p>Absolute error tolerances that apply to the individual components of the solution vector. $AbsTol(i)$ is a threshold below which the value of the ith solution component is unimportant. The absolute error tolerances determine the accuracy when the solution approaches zero. Even if you are not interested in a component $y(i)$ when it is small, you may have to specify $AbsTol(i)$ small enough to get some correct digits in $y(i)$ so that you can accurately compute more interesting components.</p> <p>If $AbsTol$ is a vector, the length of $AbsTol$ must be the same as the length of the solution vector y. If $AbsTol$ is a scalar, the value applies to all components of y.</p>
NormControl	on {off}	<p>Control error relative to norm of solution. Set this property on to request that the solvers control the error in each integration step with $norm(e) \leq \max(RelTol * norm(y), AbsTol)$. By default, the solvers use a more stringent component-wise error control.</p>

Solver Output Properties

You can use the solver output properties to control the output that the solvers generate.

DDE Solver Output Properties

Property	Value	Description
OutputFcn	Function handle {@odeplot}	<p>The output function is a function that the solver calls after every successful integration step. To specify an output function, set 'OutputFcn' to a function handle. For example,</p> <pre>options = ddeset('OutputFcn',... @myfun)</pre> <p>sets 'OutputFcn' to @myfun, a handle to the function myfun. See the function_handle reference page for more information.</p> <p>The output function must be of the form</p> <pre>status = myfun(t,y,flag)</pre> <p>“Parameterizing Functions” explains how to provide additional parameters to myfun, if necessary.</p> <p>The solver calls the specified output function with the following flags. Note that the syntax of the call differs with the flag. The function must respond appropriately:</p> <ul style="list-style-type: none"> • <code>init</code> — The solver calls <code>myfun(tspan,y0,'init')</code> before beginning the integration to allow the output function to initialize. <code>tspan</code> is the input argument to the solvers. <code>y0</code> is the initial value of the solution, either from <code>history(t0)</code> or specified in the <code>initialY</code> option. • <code>{none}</code> — The solver calls <code>status = myfun(t,y)</code> after each integration step on which output is requested. <code>t</code> contains points where output was

DDE Solver Output Properties (Continued)

Property	Value	Description
		<p>generated during the step, and <i>y</i> is the numerical solution at the points in <i>t</i>. If <i>t</i> is a vector, the <i>ith</i> column of <i>y</i> corresponds to the <i>ith</i> element of <i>t</i>.</p> <p><i>myfun</i> must return a status output value of 0 or 1. If <code>literal > status</code>, the solver halts integration. You can use this mechanism, for instance, to implement a Stop button.</p> <ul style="list-style-type: none"> • done — The solver calls <code>myfun([], [], 'done')</code> when integration is complete to allow the output function to perform any cleanup chores. <p>You can use these general purpose output functions or you can edit them to create your own. Type <code>help functionname</code> at the command line for more information.</p> <ul style="list-style-type: none"> • odeplot – time series plotting (default when you call the solver with no output argument and you have not specified an output function) • odephas2 – two-dimensional phase plane plotting • odephas3 – three-dimensional phase plane plotting • odeprint – print solution as the solver computes it
OutputSel	Vector of indices	<p>Vector of indices specifying which components of the solution vector the solvers pass to the output function. For example, if you want to use the <code>odeplot</code> output function, but you want to plot only the first and third components of the solution, you can do this using</p> <pre>options = ddeaset... ('OutputFcn',@odeplot,...</pre>

DDE Solver Output Properties (Continued)

Property	Value	Description
		'OutputSel',[1 3]); By default, the solver passes all components of the solution to the output function.
Stats	on {off}	Specifies whether the solver should display statistics about its computations. By default, Stats is off . If it is on , after solving the problem the solver displays: <ul style="list-style-type: none"> • The number of successful steps • The number of failed attempts • The number of times the DDE function was called

Step Size Properties

The step size properties let you specify the size of the first step the solver tries, potentially helping it to better recognize the scale of the problem. In addition, you can specify bounds on the sizes of subsequent time steps.

The following table describes the step size properties.

DDE Step Size Properties

Property	Value	Description
InitialStep	Positive scalar	Suggested initial step size. InitialStep sets an upper bound on the magnitude of the first step size the solver tries. If you do not set InitialStep , the solver bases the initial step size on the slope of the solution at the initial time <code>tspan(1)</code> . The initial step size is limited by the shortest delay. If the slope of all solution components is zero, the procedure might try a step size that is much too large. If you know

DDE Step Size Properties (Continued)

Property	Value	Description
		this is happening or you want to be sure that the solver resolves important behavior at the start of the integration, help the code start by providing a suitable <code>InitialStep</code> .
MaxStep	Positive scalar {0.1* abs(t0-tf)}	Upper bound on solver step size. If the differential equation has periodic coefficients or solutions, it may be a good idea to set MaxStep to some fraction (such as 1/4) of the period. This guarantees that the solver does not enlarge the time step too much and step over a period of interest. Do <i>not</i> reduce MaxStep: <ul style="list-style-type: none"> • When the solution does not appear to be accurate enough. Instead, reduce the relative error tolerance <code>RelTol</code>, and use the solution you just computed to determine appropriate values for the absolute error tolerance vector <code>AbsTol</code>. (See “Error Control Properties” on page 1-1622 for a description of the error tolerance properties.) • To make sure that the solver doesn’t step over some behavior that occurs only once during the simulation interval. If you know the time at which the change occurs, break the simulation interval into two pieces and call the solver twice. If you do not know the time at which the change occurs, try reducing the error tolerances <code>RelTol</code> and <code>AbsTol</code>. Use MaxStep as a last resort.

Event Location Property

In some DDE problems, the times of specific events are important. While solving a problem, the solvers can detect such events by locating transitions to, from, or through zeros of user-defined functions.

The following table describes the Events property.

DDE Events Property

String	Value	Description
Events	Function handle	<p>A function handle that includes one or more event functions. For <code>dde23</code> and <code>ddesd</code>, this function has the following syntax:</p> <pre>[value, isterminal, direction] = events(t, y, YDEL)</pre> <p>For <code>ddensd</code>, the syntax is:</p> <pre>[value, isterminal, direction] = events(t, y, YDEL, YPDEL)</pre> <p>The output arguments, <code>value</code>, <code>isterminal</code>, and <code>direction</code>, are vectors for which the <code>ith</code> element corresponds to the <code>ith</code> event function:</p> <ul style="list-style-type: none">• <code>value(i)</code> is the value of the <code>ith</code> event function.• <code>isterminal(i) = 1</code> if you want the integration to terminate at a zero of this event function, and <code>0</code> otherwise.• <code>direction(i) = 0</code> if you want the solver to locate all zeros (the default), <code>+1</code> if only zeros where the event function is increasing, and <code>-1</code> if only zeros where the event function is decreasing. <p>If you specify an events function and events are detected, the solver returns three additional fields in the solution structure <code>sol</code>:</p> <ul style="list-style-type: none">• <code>sol.xe</code> is a row vector of times at which events occur.• <code>sol.ye</code> is a matrix whose columns are the solution values corresponding to times in <code>sol.xe</code>.• <code>sol.ie</code> is a vector containing indices that specify which event occurred at the corresponding time in <code>sol.xe</code>.

DDE Events Property (Continued)

String	Value	Description
		For examples that use an event function while solving ordinary differential equation problems, see “Event Location” (<code>ballode</code>) and “Advanced Event Location” (<code>orbitode</code>), in the MATLAB Mathematics documentation.

Discontinuity Properties

The solver functions can solve problems with discontinuities in the history or in the coefficients of the equations. The following properties enable you to provide these solvers with a different initial value, and, for `dde23`, locations of known discontinuities. For more information, see “Discontinuities in DDEs”.

The following table describes the discontinuity properties.

DDE Discontinuity Properties

String	Value	Description
<code>Jumps</code>	Vector	Location of discontinuities. Points t where the history or solution may have a jump discontinuity in a low-order derivative. This applies only to the <code>dde23</code> solver.
<code>InitialY</code>	Vector	Initial value of solution. By default the initial value of the solution is the value returned by <code>history</code> at the initial point. Supply a different initial value as the value of the <code>InitialY</code> property.

Examples

To create an options structure that changes the relative error tolerance of the solver from the default value of $1e-3$ to $1e-4$, enter

```
options = ddeset('RelTol',1e-4);
```

ddeset

To recover the value of 'RelTol' from options, enter

```
ddeget(options,'RelTol')
```

```
ans =
```

```
1.0000e-004
```

See Also

[dde23](#) | [ddensd](#) | [ddesd](#) | [ddeget](#) | [function_handle](#)

Purpose Distribute inputs to outputs

Note Beginning with MATLAB Version 7.0 software, you can access the contents of cell arrays and structure fields without using the `deal` function. See Example 3, below.

Syntax

```
[Y1, Y2, Y3, ...] = deal(X)
[Y1, Y2, Y3, ...] = deal(X1, X2, X3, ...)
[S.field] = deal(X)
[X{:}] = deal(A.field)
[Y1, Y2, Y3, ...] = deal(X{:})
[Y1, Y2, Y3, ...] = deal(S.field)
```

Description

`[Y1, Y2, Y3, ...] = deal(X)` copies the single input to all the requested outputs. It is the same as `Y1 = X, Y2 = X, Y3 = X, ...`

`[Y1, Y2, Y3, ...] = deal(X1, X2, X3, ...)` is the same as `Y1 = X1; Y2 = X2; Y3 = X3; ...`

Tips

`deal` is most useful when used with cell arrays and structures via comma-separated list expansion. Here are some useful constructions:

`[S.field] = deal(X)` sets all the fields with the name `field` in the structure array `S` to the value `X`. If `S` doesn't exist, use `[S(1:m).field] = deal(X)`.

`[X{:}] = deal(A.field)` copies the values of the field with name `field` to the cell array `X`. If `X` doesn't exist, use `[X{1:m}] = deal(A.field)`.

`[Y1, Y2, Y3, ...] = deal(X{:})` copies the contents of the cell array `X` to the separate variables `Y1, Y2, Y3, ...`

`[Y1, Y2, Y3, ...] = deal(S.field)` copies the contents of the fields with the name `field` to separate variables `Y1, Y2, Y3, ...`

Examples

Example 1 – Assign Data From a Cell Array

Use `deal` to copy the contents of a 4-element cell array into four separate output variables.

```
C = {rand(3) ones(3,1) eye(3) zeros(3,1)};
[a,b,c,d] = deal(C{:})
```

```
a =
    0.9501    0.4860    0.4565
    0.2311    0.8913    0.0185
    0.6068    0.7621    0.8214
```

```
b =
     1
     1
     1
```

```
c =
     1     0     0
     0     1     0
     0     0     1
```

```
d =
     0
     0
     0
```

Example 2 – Assign Data From Structure Fields

Use `deal` to obtain the contents of all the name fields in a structure array:

```
A.name = 'Pat'; A.number = 176554;
A(2).name = 'Tony'; A(2).number = 901325;
[name1,name2] = deal(A(:).name)
```

```
name1 =
    Pat
```

```
name2 =  
    Tony
```

Example 3 – Doing the Same Without deal

Beginning with MATLAB Version 7.0 software, you can, in most cases, access the contents of cell arrays and structure fields without using the `deal` function. The two commands shown below perform the same operation as those used in the previous two examples, except that these commands do not require `deal`.

```
[a,b,c,d] = C{:}  
[name1,name2] = A(:).name
```

See Also

```
cell | iscell | celldisp | struct | isstruct | fieldnames |  
isfield | orderfields | rmfield | cell2struct | struct2cell
```

deblank

Purpose Strip trailing blanks from end of string

Syntax `str = deblank(str)`
`c = deblank(c)`

Description `str = deblank(str)` removes all trailing whitespace and null characters from the end of character string `str`. A whitespace is any character for which the `isspace` function returns logical 1 (`true`).

`c = deblank(c)` when `c` is a cell array of strings, applies `deblank` to each element of `c`.

The `deblank` function is useful for cleaning up the rows of a character array.

Examples

Example 1 – Removing Trailing Blanks From a String

Compose a string `str` that contains space, tab, and null characters:

```
NL = char(0);    TAB = char(9);  
str = [NL 32 TAB NL 'AB' 32 NL 'CD' NL 32 TAB NL 32];
```

Display all characters of the string between `|` symbols:

```
['|' str '|']  
ans =  
    |    AB  CD    |
```

Remove trailing whitespace and null characters, and redisplay the string:

```
newstr = deblank(str);  
  
['|' newstr '|']  
ans =  
    |    AB  CD|
```

Example 2- Removing Trailing Blanks From a Cell Array of Strings

Create a 2-by-2 cell array in which each cell contains a word with trailing blanks:

```
A{1,1} = 'MATLAB   ' ;  
A{1,2} = 'SIMULINK   ' ;  
A{2,1} = 'Toolboxes   ' ;  
A{2,2} = 'MathWorks   ' ;  
A =  
    'MATLAB   '      'SIMULINK   '  
    'Toolboxes   '  'MathWorks   '
```

Remove the trailing blanks and redisplay the cell array:

```
A = deblank(A);  
  
A  
A =  
    'MATLAB'      'SIMULINK'  
    'Toolboxes'  'MathWorks'
```

See Also

[strjust](#) | [strtrim](#)

dec2base

Purpose Convert decimal to base N number in string

Syntax `str = dec2base(d, base)`
`str = dec2base(d, base, n)`

Description `str = dec2base(d, base)` converts the nonnegative integer `d` to the specified base. `d` must be a nonnegative integer smaller than 2^{52} , and `base` must be an integer between 2 and 36. The returned argument `str` is a string.

`str = dec2base(d, base, n)` produces a representation with at least `n` digits.

Examples The expression `dec2base(23, 2)` converts 23_{10} to base 2, returning the string `'10111'`.

See Also `base2dec`

Purpose Convert decimal to binary number in string

Syntax `str = dec2bin(d)`
`str = dec2bin(d,n)`

Description returns the
`str = dec2bin(d)` binary representation of `d` as a string. `d` must be a nonnegative integer smaller than 2^{52} .
`str = dec2bin(d,n)` produces a binary representation with at least `n` bits.
The output of `dec2bin` is independent of the endian settings of the computer you are using.

Examples Decimal 23 converts to binary 010111:

```
dec2bin(23)
ans =
    10111
```

See Also [bin2dec](#) | [dec2hex](#)

dec2hex

Purpose Convert decimal to hexadecimal number in string

Syntax `str = dec2hex(d)`
`str = dec2hex(d, n)`

Description `str = dec2hex(d)` converts the decimal integer `d` to its hexadecimal representation stored in a MATLAB string. `d` must be a nonnegative integer smaller than 2^{52} . MATLAB converts noninteger inputs, such as those of class `double` or `char`, to their integer equivalents before converting to hexadecimal.

`str = dec2hex(d, n)` produces a hexadecimal representation with at least `n` digits.

Examples To convert decimal 1023 to hexadecimal,

```
dec2hex(1023)
ans =
    3FF
```

```
dec2hex(1023, 6)
ans =
0003FF
```

Convert 2-by-5 array `A` to hexadecimal:

```
A = [3487,    125,  8997,  1433,  189; ...
      771,  84832,   118,  9366,  212];
```

<code>A(:)</code>	<code>dec2hex(A)</code>
<code>ans =</code>	<code>ans =</code>
3487	00D9F
771	00303
125	0007D
84832	14B60
8997	02325
118	00076
1433	00599

9366	02496
189	000BD
212	000D4

See Also

[dec2bin](#) | [format](#) | [hex2dec](#) | [hex2num](#)

decic

Purpose

Compute consistent initial conditions for ode15i

Syntax

```
[y0mod,yp0mod] = decic(odefun,t0,y0,fixed_y0,yp0,fixed_yp0)
[y0mod,yp0mod] = decic(odefun,t0,y0,fixed_y0,yp0,fixed_yp0,options)
[y0mod,yp0mod,resnrm] = decic(odefun,t0,y0,fixed_y0,yp0,fixed_yp0...)
```

Description

`[y0mod,yp0mod] = decic(odefun,t0,y0,fixed_y0,yp0,fixed_yp0)` uses the inputs `y0` and `yp0` as initial guesses for an iteration to find output values that satisfy the requirement $f(t0, y0mod, yp0mod) = 0$, i.e., `y0mod` and `yp0mod` are consistent initial conditions. `odefun` is a function handle. The function `decic` changes as few components of the guesses as possible. You can specify that `decic` holds certain components fixed by setting `fixed_y0(i) = 1` if no change is permitted in the guess for `y0(i)` and 0 otherwise. `decic` interprets `fixed_y0 = []` as allowing changes in all entries. `fixed_yp0` is handled similarly.

“Parameterizing Functions” explains how to provide additional parameters to the function `odefun`, if necessary.

You cannot fix more than `length(y0)` components. Depending on the problem, it may not be possible to fix this many. It also may not be possible to fix certain components of `y0` or `yp0`. It is recommended that you fix no more components than necessary.

`[y0mod,yp0mod] = decic(odefun,t0,y0,fixed_y0,yp0,fixed_yp0,options)` computes as above with default tolerances for consistent initial conditions, `AbsTol` and `RelTol`, replaced by the values in `options`, a structure you create with the `odeset` function.

`[y0mod,yp0mod,resnrm] = decic(odefun,t0,y0,fixed_y0,yp0,fixed_yp0...)` returns the norm of `odefun(t0,y0mod,yp0mod)` as `resnrm`. If the norm seems unduly large, use `options` to decrease `RelTol` ($1e-3$ by default).

Examples

The files, `ihb1dae.m` and `iburgersode.m`, provide examples which use `decic` to solve implicit ODEs.

See Also

ode15i | odeget | odeset | function_handle

deconv

Purpose Deconvolution and polynomial division

Syntax $[q,r] = \text{deconv}(v,u)$

Description $[q,r] = \text{deconv}(v,u)$ deconvolves vector u out of vector v , using long division. The quotient is returned in vector q and the remainder in vector r such that $v = \text{conv}(u,q)+r$.

If u and v are vectors of polynomial coefficients, convolving them is equivalent to multiplying the two polynomials, and deconvolution is polynomial division. The result of dividing v by u is quotient q and remainder r .

Examples

If

```
u = [1 2 3 4]
v = [10 20 30]
```

the convolution is

```
c = conv(u,v)
c =
    10    40   100   160   170   120
```

Use deconvolution to recover u :

```
[q,r] = deconv(c,u)
q =
    10    20    30
r =
    0     0     0     0     0     0
```

This gives a quotient equal to v and a zero remainder.

Algorithms `deconv` uses the `filter` primitive.

See Also `conv` | `residue`

Purpose	Discrete Laplacian
Syntax	<code>L = del2(U)</code> <code>L = del2(U,h)</code> <code>L = del2(U,h1,...,hN)</code>
Description	<p><code>L = del2(U)</code> returns a discrete approximation of Laplace's differential operator applied to <code>U</code> using the default spacing, <code>h = 1</code>, between all points.</p> <p><code>L = del2(U,h)</code> specifies a uniform, scalar spacing, <code>h</code>, between points in all dimensions of <code>U</code>.</p> <p><code>L = del2(U,h1,...,hN)</code> specifies the spacing, <code>h1,...,hN</code>, between points in each corresponding dimension of <code>U</code>. For each dimension, specify the spacing as a scalar or a vector of coordinates. The number of spacing inputs must equal the number of dimensions in <code>U</code>.</p>
Input Arguments	<p>U - Input array vector matrix multidimensional array Input array, specified as a vector, matrix, or multidimensional array.</p> <p>Data Types single double Complex Number Support: Yes</p> <p>h - Spacing in all dimensions 1 (default) scalar Spacing in all dimensions, specified as 1 (default), or a scalar.</p> <p>Data Types single double Complex Number Support: Yes</p> <p>h1,...,hN - Spacing in each dimension</p>

scalars | vectors

Spacing in each dimension, specified as scalars or vectors. The number of spacing inputs must be equal to the number of dimensions in U . Each spacing input defines the spacing between points in the corresponding dimension of U :

- Use a scalar to specify a uniform spacing.
- Use a vector to specify a nonuniform spacing. The coordinate vector gives the position of each point and must have the same number of elements as the corresponding dimension of U (a one-to-one match of coordinates and points).

Data Types

single | double

Complex Number Support: Yes

Output Arguments

L - Discrete Laplacian approximation

vector | matrix | multidimensional array

Discrete Laplacian approximation, returned as a vector, matrix, or multidimensional array. L is the same size as the input, U .

Examples

Second Derivative of Vector

Calculate the acceleration of an object from a vector of position data.

Create a vector of position data.

```
p = [1 3 6 10 16 18 29];
```

To find the acceleration of the object, use `de12` to calculate the second numerical derivative of p . Use the default spacing $h = 1$ between data points.

```
L = 4*de12(p)
```

```
L =
```

```
1 1 1 2 -4 9 22
```

Each value of L is an approximation of the instantaneous acceleration at that point.

Second Derivative of Cosine Vector

Calculate the discrete 1-D Laplacian of a cosine vector.

Define the domain of the function.

```
x = linspace(-2*pi,2*pi);
```

This produces 100 evenly spaced points in the range $-2\pi \leq x \leq 2\pi$.

Create a vector of cosine values in this domain.

```
U = cos(x);
```

Calculate the Laplacian of U using `del2`. Use the domain vector x to define the 1-D coordinate of each point in U .

```
L = 4*del2(U,x);
```

Analytically, the Laplacian of this function is equal to $\Delta U = -\cos(x)$.

Plot the results.

```
plot(x,U,x,L);legend('U(x)', 'L(x)', 'Location', 'Best')
```

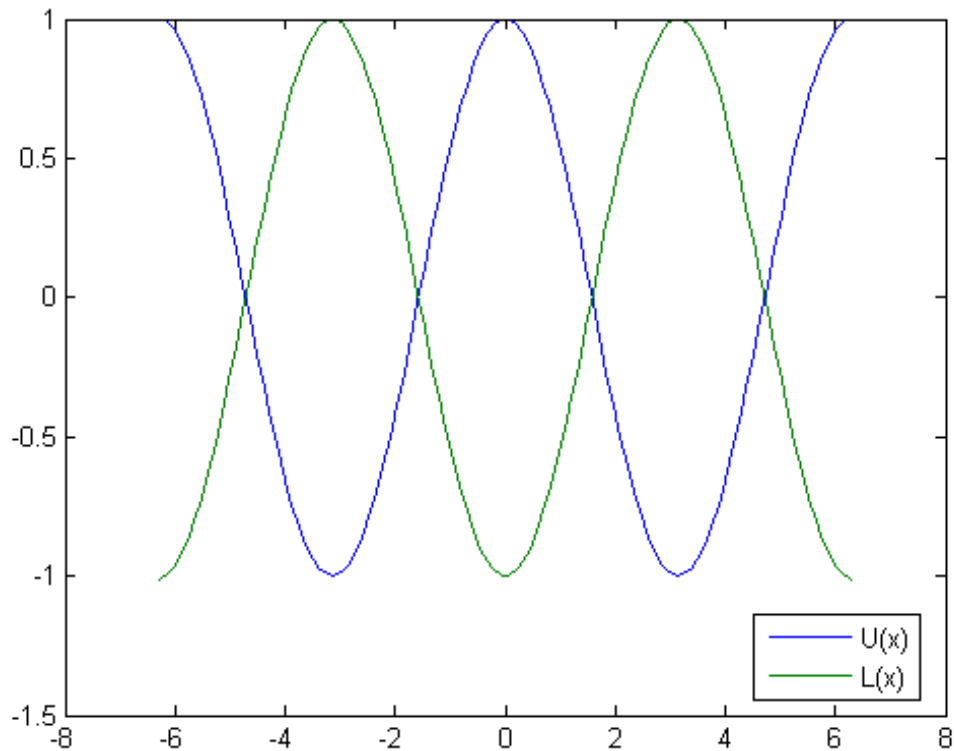

The graph of U and L agrees with the analytic result for the Laplacian.

Laplacian of Multivariate Function

Calculate and plot the discrete Laplacian of a multivariate function.

Define the x and y domain of the function.

```
[x,y] = meshgrid(-5:0.25:5, -5:0.25:5);
```

Define the function $U(x, y) = \frac{1}{3}(x^4 + y^4)$ over this domain.

```
U = 1/3.*(x.^4+y.^4);
```

Calculate the Laplacian of this function using `del2`. The spacing between the points in `U` is equal in all directions, so you can specify a single spacing input, `h`.

```
h = 0.25;  
L = 4*del2(U,h);
```

Analytically, the Laplacian of this function is equal to $\Delta U(x,y) = 4x^2 + 4y^2$.

Plot the discrete Laplacian, `L`.

```
figure;hold on;grid on;  
title('Plot of  $\Delta U(x,y) = 4x^2+4y^2$ ','Interpreter','latex')  
xlabel('x'); ylabel('y'); zlabel('z');  
surf(x,y,L);  
view(35,14)
```

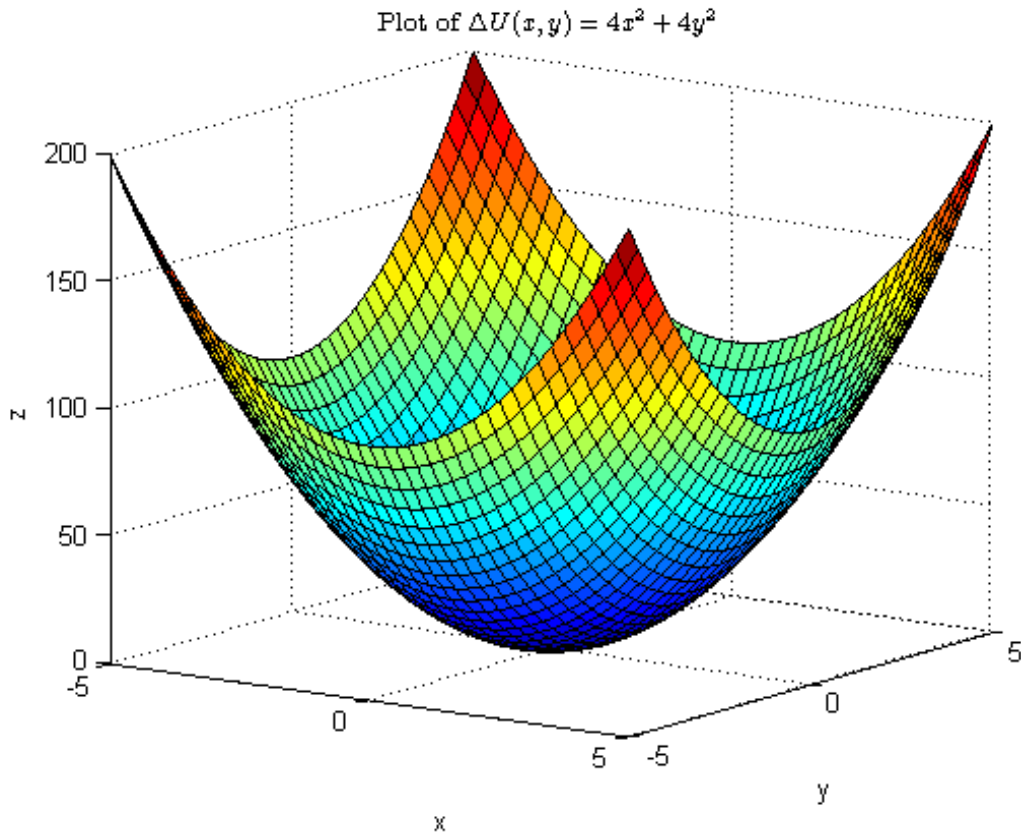

The graph of L agrees with the analytic result for the Laplacian.

Laplacian of Natural Logarithm Function

Calculate the discrete Laplacian of a natural logarithm function.

Define the x and y domain of the function on a grid of real numbers.

```
[x,y] = meshgrid(-5:5, -5:0.5:5);
```

Define the function $U(x,y) = \frac{1}{2} \log(x^2y)$ over this domain.

```
U = 0.5*log(x.^2.*y);
```

The logarithm is complex-valued when the argument y is negative.

Use `del2` to calculate the discrete Laplacian of this function. Specify the spacing between grid points in each direction.

```
hx = 1;  
hy = 0.5;  
L = 4*del2(U,hx,hy);
```

Analytically, the Laplacian is equal to $\Delta U(x,y) = -\left(\frac{1}{x^2} + \frac{1}{2y^2}\right)$. This function is not defined on the lines $x = 0$ or $y = 0$.

Plot the real parts of U and L on the same graph.

```
figure;hold on;grid on;  
title('Plot of U(x,y) and  $\Delta U(x,y)$ ','Interpreter','latex')  
xlabel('x'); ylabel('y'); zlabel('z');  
surf(x,y,real(L)); surf(x,y,real(U));  
view(41,58)
```

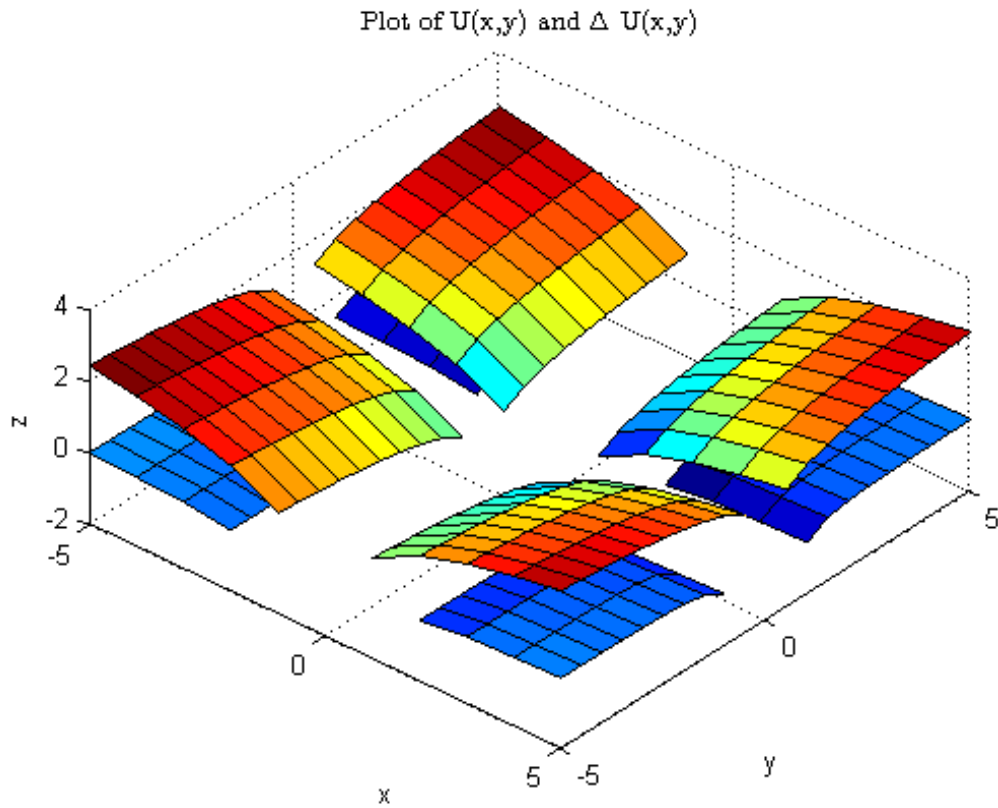

The top surface is U and the bottom surface is L .

Definitions

Laplace's differential operator

If a matrix U is a function $U(x,y)$ that is evaluated at the points of a square grid, then $4*\text{del2}(U)$ is a finite difference approximation of Laplace's differential operator applied to U ,

$$L = \frac{\Delta U}{4} = \frac{1}{4} \left(\frac{\partial^2 U}{\partial x^2} + \frac{\partial^2 U}{\partial y^2} \right).$$

For functions of more variables, $U(x,y,z,\dots)$, the discrete Laplacian `del2(U)` calculates second-derivatives in each dimension,

$$L = \frac{\Delta U}{2N} = \frac{1}{2N} \left(\frac{\partial^2 U}{\partial x^2} + \frac{\partial^2 U}{\partial y^2} + \frac{\partial^2 U}{\partial z^2} + \dots \right),$$

where N is the number of dimensions in U and $N \geq 2$.

Algorithms

If the input U is a matrix, the interior points of L are found by taking the difference between a point in U and the average of its four neighbors:

$$L_{ij} = \sum_i \sum_j \left[\frac{(u_{i+1,j} + u_{i-1,j} + u_{i,j+1} + u_{i,j-1})}{4} - u_{i,j} \right].$$

Then, `del2` calculates the values on the edges of L by linearly extrapolating the second differences from the interior. This formula is extended for multidimensional U .

See Also

`diff` | `gradient`

DelaunayTri

Superclasses TriRep

Purpose (Will be removed) Delaunay triangulation in 2-D and 3-D

Note DelaunayTri will be removed in a future release. Use delaunayTriangulation instead.

Description DelaunayTri creates a Delaunay triangulation object from a set of points. You can incrementally modify the triangulation by adding or removing points. In 2-D triangulations you can impose edge constraints. You can perform topological and geometric queries, and compute the Voronoi diagram and convex hull.

Definitions The 2-D Delaunay triangulation of a set of points is the triangulation in which no point of the set is contained in the circumcircle for any triangle in the triangulation. The definition extends naturally to higher dimensions.

Construction DelaunayTri (Will be removed) Construct Delaunay triangulation

Methods

convexHull	(Will be removed) Convex hull
inOutStatus	(Will be removed) Status of triangles in 2-D constrained Delaunay triangulation
nearestNeighbor	(Will be removed) Point closest to specified location

pointLocation	(Will be removed) Simplex containing specified location
voronoiDiagram	(Will be removed) Voronoi diagram

Inherited methods

baryToCart	(Will be removed) Convert point coordinates from barycentric to Cartesian
cartToBary	(Will be removed) Convert point coordinates from cartesian to barycentric
circumcenters	(Will be removed) Circumcenters of specified simplices
edgeAttachments	(Will be removed) Simplices attached to specified edges
edges	(Will be removed) Triangulation edges
faceNormals	(Will be removed) Unit normals to specified triangles
featureEdges	(Will be removed) Sharp edges of surface triangulation
freeBoundary	(Will be removed) Facets referenced by only one simplex
incenters	(Will be removed) Incenters of specified simplices
isEdge	(Will be removed) Test if vertices are joined by edge
neighbors	(Will be removed) Simplex neighbor information

DelaunayTri

size	(Will be removed) Size of triangulation matrix
vertexAttachments	(Will be removed) Return simplices attached to specified vertices

Properties

Constraints	<p>Constraints is a numc-by-2 matrix that defines the constrained edge data in the triangulation, where numc is the number of constrained edges. Each constrained edge is defined in terms of its endpoint indices into X.</p> <p>The constraints can be specified when the triangulation is constructed or can be imposed afterwards by directly editing the constraints data.</p> <p>This feature is only supported for 2-D triangulations.</p>
X	<p>The dimension of X is mpts-by-ndim, where mpts is the number of points and ndim is the dimension of the space where the points reside. If column vectors of x,y or x,y,z coordinates are used to construct the triangulation, the data is consolidated into a single matrix X.</p>
Triangulation	<p>Triangulation is a matrix representing the set of simplices (triangles or tetrahedra etc.) that make up the triangulation. The matrix is of size mtri-by-nv, where mtri is the number of simplices and nv is the number of vertices per simplex. The triangulation is represented by standard simplex-vertex format; each row specifies a simplex defined by indices into X, where X is the array of point coordinates.</p>

Instance Hierarchy

DelaunayTri is a subclass of TriRep.

Copy Semantics

Value. To learn how this affects your use of the class, see Comparing Handle and Value Classes in the MATLAB Object-Oriented Programming documentation.

See Also

[scatteredInterpolant](#) | [triangulation](#) | [delaunayTriangulation](#)

DelaunayTri

Purpose (Will be removed) Construct Delaunay triangulation

Note DelaunayTri will be removed in a future release. Use delaunayTriangulation instead.

Syntax

```
DT = DelaunayTri()  
DT = DelaunayTri(X)  
DT = DelaunayTri(x,y)  
DT = DelaunayTri(x,y,z)  
DT = DelaunayTri(..., C)
```

Description

DT = DelaunayTri() creates an empty Delaunay triangulation.

DT = DelaunayTri(X), DT = DelaunayTri(x,y) and DT = DelaunayTri(x,y,z) create a Delaunay triangulation from a set of points. The points can be specified as an mpts-by-ndim matrix X, where mpts is the number of points and ndim is the dimension of the space where the points reside, where ndim is 2 or 3. Alternatively, the points can be specified as column vectors (x,y) or (x,y,z) for 2-D and 3-D input.

DT = DelaunayTri(..., C) creates a constrained Delaunay triangulation. The edge constraints C are defined by an numc-by-2 matrix, numc being the number of constrained edges. Each row of C defines a constrained edge in terms of its endpoint indices into the point set X. This feature is only supported for 2-D triangulations.

Definitions

The 2-D Delaunay triangulation of a set of points is the triangulation in which no point of the set is contained in the circumcircle for any triangle in the triangulation. The definition extends naturally to higher dimensions.

Examples

Compute the Delaunay triangulation of twenty random points located within a unit square.

```
x = rand(20,1);
```

```
y = rand(20,1);  
dt = DelaunayTri(x,y)  
triplot(dt);
```

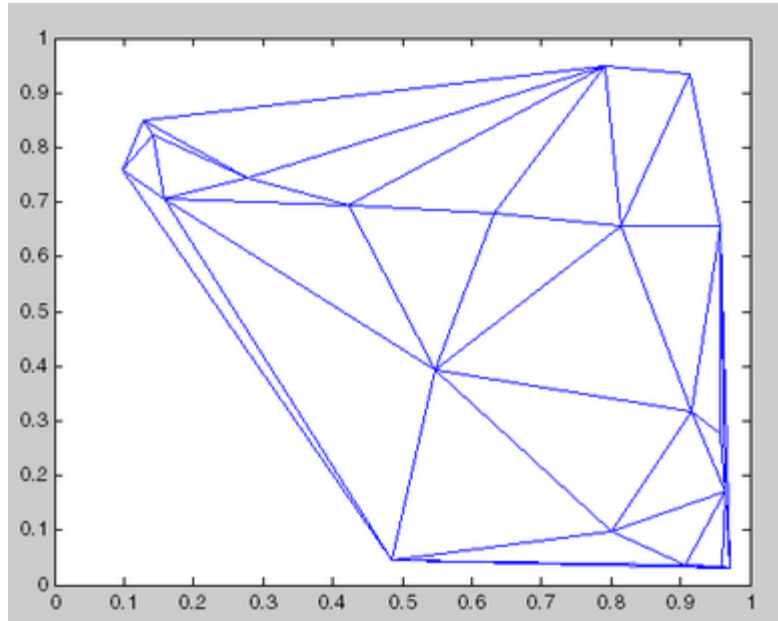

For more examples, type `help demoDelaunayTri` at the MATLAB command-line prompt.

See Also

[scatteredInterpolant](#) | [triangulation](#) | [delaunayTriangulation](#)

delaunay

Purpose Delaunay triangulation

Note Qhull-specific options are no longer supported. Remove the `OPTIONS` argument from all instances in your code that pass it to `delaunay`.

Syntax

```
TRI = delaunay(X,Y)
TRI = delaunay(X,Y,Z)
TRI = delaunay(X)
```

Definitions `delaunay` creates a Delaunay triangulation of a set of points in 2-D or 3-D space. A 2-D Delaunay triangulation ensures that the circumcircle associated with each triangle contains no other point in its interior. This definition extends naturally to higher dimensions.

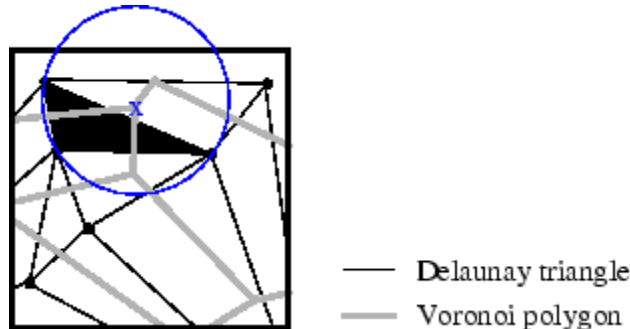

Description `TRI = delaunay(X,Y)` creates a 2-D Delaunay triangulation of the points (X,Y) , where X and Y are column-vectors. `TRI` is a matrix representing the set of triangles that make up the triangulation. The matrix is of size `mtri-by-3`, where `mtri` is the number of triangles. Each row of `TRI` specifies a triangle defined by indices with respect to the points.

`TRI = delaunay(X,Y,Z)` creates a 3-D Delaunay triangulation of the points (X,Y,Z) , where X , Y , and Z are column-vectors. `TRI` is a matrix

representing the set of tetrahedra that make up the triangulation. The matrix is of size `mtri-by-4`, where `mtri` is the number of tetrahedra. Each row of `TRI` specifies a tetrahedron defined by indices with respect to the points.

`TRI = delaunay(X)` creates a 2-D or 3-D Delaunay triangulation from the point coordinates `X`. This variant supports the definition of points in matrix format. `X` is of size `mpts-by-ndim`, where `mpts` is the number of points and `ndim` is the dimension of the space where the points reside, $2 \leq \text{ndim} \leq 3$. The output triangulation is equivalent to that of the dedicated functions supporting the 2-input or 3-input calling syntax.

`delaunay` produces an isolated triangulation, useful for applications like plotting surfaces via the `trisurf` function. If you wish to query the triangulation; for example, to perform nearest neighbor, point location, or topology queries, use `delaunayTriangulation` instead.

Visualization

Use one of these functions to plot the output of `delaunay`:

- | | |
|----------------------|--|
| <code>triplot</code> | Displays the triangles defined in the <code>m-by-3</code> matrix <code>TRI</code> . |
| <code>trisurf</code> | Displays each triangle defined in the <code>m-by-3</code> matrix <code>TRI</code> as a surface in 3-D space. To see a 2-D surface, you can supply a vector of some constant value for the third dimension. For example |

```
trisurf(TRI,x,y,zeros(size(x)))
```

delaunay

`trimesh` Displays each triangle defined in the m-by-3 matrix TRI as a mesh in 3-D space. To see a 2-D surface, you can supply a vector of some constant value for the third dimension. For example,

```
trimesh(TRI,x,y,zeros(size(x)))
```

produces almost the same result as `triplot`, except in 3-D space.

`tetramesh` Plots a triangulation composed of tetrahedra.

Examples

Plot Delaunay Triangulation

Plot the Delaunay triangulation of a large dataset.

```
load seamount
tri = delaunay(x,y);
trisurf(tri,x,y,z);
```

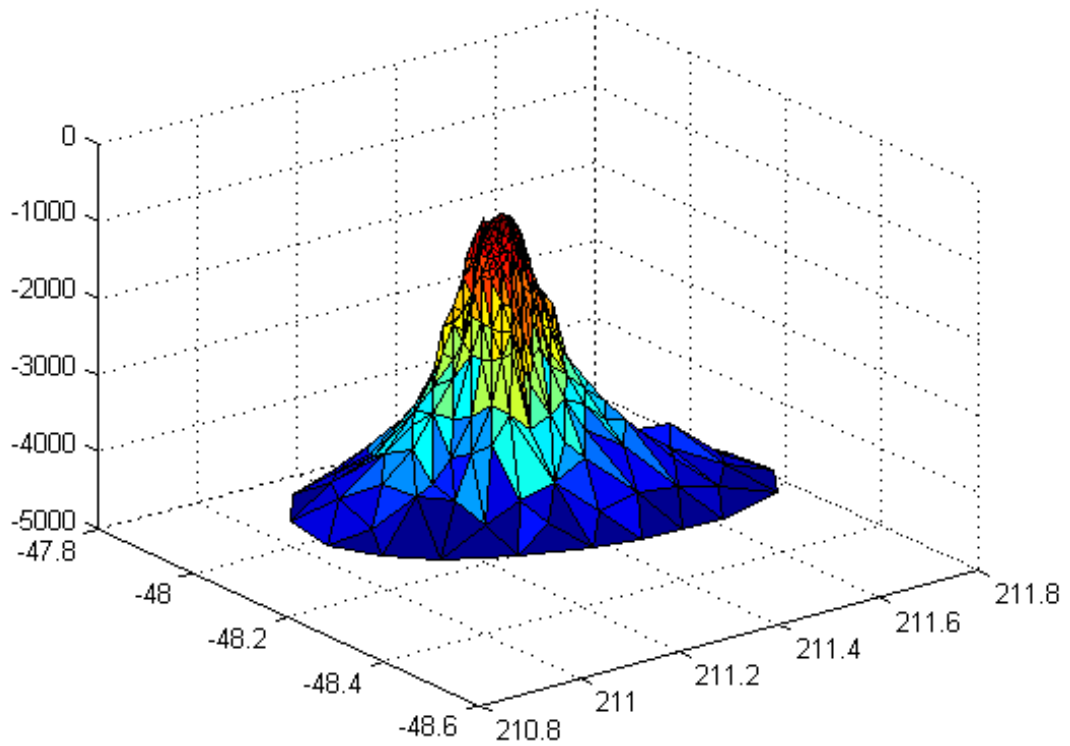
**See Also**

[delaunayTriangulation](#) | [scatteredInterpolant](#) | [plot](#) | [triplot](#) | [trimesh](#) | [trisurf](#)

delaunayn

Purpose N-D Delaunay triangulation

Syntax `T = delaunayn(X)`
`T = delaunayn(X, options)`

Description `T = delaunayn(X)` computes a set of simplices such that no data points of `X` are contained in any circumspheres of the simplices. The set of simplices forms the Delaunay triangulation. `X` is an `m`-by-`n` array representing `m` points in `n`-dimensional space. `T` is a `numt`-by-`(n+1)` array where each row contains the indices into `X` of the vertices of the corresponding simplex.

`T = delaunayn(X, options)` specifies a cell array of strings options. The default options are:

- `{'Qt', 'Qbb', 'Qc'}` for 2- and 3-dimensional input
- `{'Qt', 'Qbb', 'Qc', 'Qx'}` for 4 and higher-dimensional input

If options is `[]`, the default options used. If options is `{''}`, no options are used, not even the default.

Visualization Plotting the output of `delaunayn` depends of the value of `n`:

- For `n = 2`, use `triplot`, `trisurf`, or `trimesh` as you would for `delaunay`.
- For `n = 3`, use `tetramesh`.

For more control over the color of the facets, use `patch` to plot the output.

- You cannot plot `delaunayn` output for `n > 3`.

Examples **3-D Delaunay Triangulation**

This example generates an `n`-dimensional Delaunay triangulation, where `n = 3`.

```
d = [-1 1];  
[x,y,z] = meshgrid(d,d,d); % A cube
```



```
x = [x(:);0];
y = [y(:);0];
z = [z(:);0];
% [x,y,z] are corners of a cube plus the center.
X = [x(:) y(:) z(:)];
Tes = delaunayn(X)
```

Tes =

4	3	9	1
4	9	2	1
7	9	3	1
7	5	9	1
7	9	4	3
7	8	4	9
6	2	9	1
6	9	5	1
6	4	9	2
6	4	8	9
6	9	7	5
6	8	7	9

You can use `tetramesh` to visualize the tetrahedrons that form the corresponding simplex. `camorbit` rotates the camera position to provide a meaningful view of the figure.

```
tetramesh(Tes,X);camorbit(20,0)
```

del aunayn

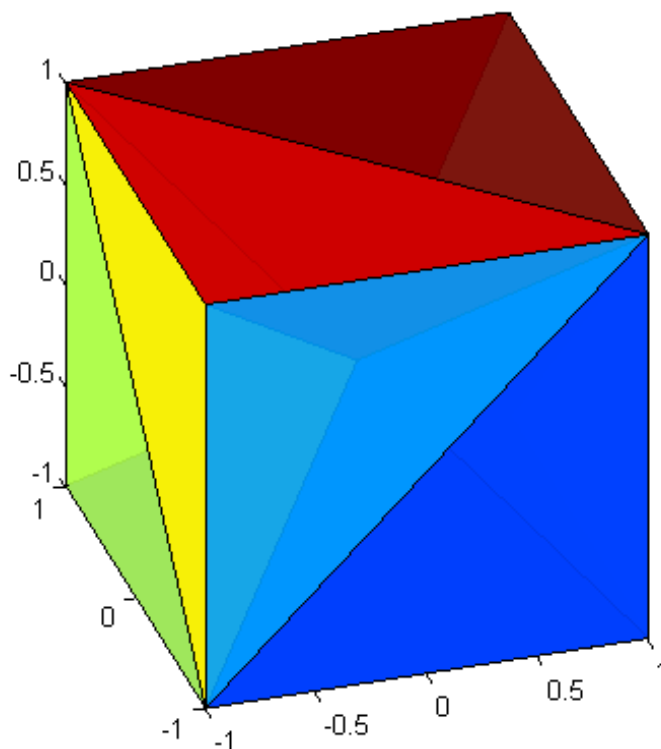

See Also

[del aunayTriangulation](#) | [convhulln](#) | [tetramesh](#) | [voronoin](#) | [camorbit](#)

Superclasses triangulation

Purpose Delaunay triangulation in 2-D and 3-D

Description Use the `delaunayTriangulation` class to create a 2-D or 3-D triangulation from a set of points. When your points are in 2-D, you can specify edge constraints .

You can perform a variety of topological and geometric queries on a `delaunayTriangulation`, including any triangulation query. For example, locate a facet that contains a specific point, find the vertices of the convex hull, or compute the Voronoi Diagram.

Construction `DT = delaunayTriangulation(P)` creates a Delaunay triangulation from the points in `P`. Matrix `P` has 2 or 3 columns, depending on whether your points are in 2-D or 3-D space.

`DT = delaunayTriangulation(P,C)` specifies the edge constraints in matrix `C`. In this case, `P` specifies points in 2-D. Each row of `C` defines the start and end vertex IDs of a constrained edge.

`DT = delaunayTriangulation(x,y)` creates a 2-D Delaunay triangulation from the point coordinates in the column vectors, `x` and `y`.

`DT = delaunayTriangulation(x,y,C)` specifies the edge constraints in matrix `C`.

`DT = delaunayTriangulation(x,y,z)` creates a 3-D Delaunay triangulation from the point coordinates in the column vectors, `x`, `y`, and `z`.

`DT = delaunayTriangulation()` creates an empty Delaunay triangulation.

Input Arguments

P

del aunayTriangulation

Input points, specified as a matrix whose columns are the x , y , (and possibly z) coordinates of the triangulation points. The row numbers of P are the vertex IDs in the triangulation.

x

x -coordinates vector, specified as a column vector containing the x -coordinates of the triangulation points.

y

y -coordinates vector, specified as a column vector containing the y -coordinates of the triangulation points.

z

z -coordinates vector, specified as a column vector containing the z -coordinates of the triangulation points.

C

Vertex IDs of constrained edges, specified as a 2-column matrix. Each row of C corresponds to a constrained edge and contains two IDs:

- $C(j, 1)$ is the ID of the vertex at the start of an edge.
- $C(j, 2)$ is the ID of the vertex at end of the edge.

You can specify edge constraints for 2-D triangulations only.

Properties

Points

Points in the triangulation, represented as a matrix containing the following information:

- Each row in $DT.Points$ contains the coordinates of a vertex.
- Each row number of $DT.Points$ is a vertex ID.

ConnectivityList

Triangulation connectivity list, represented as a matrix. This matrix contains the following information:

- Each row represents a triangle or tetrahedron in the triangulation.
- Each row number of `DT.ConnectivityList` is a “Triangle or Tetrahedron ID” on page 1-1669.
- Each element is a vertex ID.

Constraints

Constrained edges, represented as a two-column matrix of vertex IDs. Each row of `DT.Constraints` corresponds to a constrained edge and contains two IDs:

- `DT.Constraints(j,1)` is the ID of the vertex at the start of an edge.
- `DT.Constraints(j,2)` is the ID of the vertex at end of the edge.

`DT.Constraints` is an empty matrix when the triangulation has no constrained edges.

Methods

<code>convexHull</code>	Convex hull
<code>isInterior</code>	Test if triangle is in interior of 2-D constrained Delaunay triangulation
<code>nearestNeighbor</code>	Vertex closest to specified location
<code>pointLocation</code>	Triangle or tetrahedron containing specified location
<code>voronoiDiagram</code>	Voronoi diagram

deLaunayTriangulation

Inherited Methods

barycentricToCartesian	Converts point coordinates from barycentric to Cartesian
cartesianToBarycentric	Converts point coordinates from Cartesian to barycentric
circumcenter	Circumcenter of triangle or tetrahedron
edgeAttachments	Triangles or tetrahedra attached to specified edge
edges	Triangulation edges
faceNormal	Triangulation face normal
featureEdges	Triangulation sharp edges
freeBoundary	Triangulation facets referenced by only one triangle or tetrahedron
incenter	Incenter of triangle or tetrahedron
isConnected	Test if two vertices are connected by edge
neighbors	Neighbors to specified triangle or tetrahedron
size	Size of triangulation connectivity list
vertexAttachments	Triangles or tetrahedra attached to specified vertex
vertexNormal	Triangulation vertex normal

Definitions

Delaunay Triangulation

In a 2-D Delaunay triangulation, the circumcircle associated with each triangle does not contain any points in its interior. Similarly, a 3-D Delaunay triangulation does not have any points in the interior of the circumsphere associated with each tetrahedron. This definition extends to N-D, although `delaunayTriangulation` supports only 2-D and 3-D.

Vertex ID

A row number of the matrix, `DT.Points`. Use this ID to refer a specific vertex in the triangulation.

Triangle or Tetrahedron ID

A row number of the matrix, `DT.ConnectivityList`. Use this ID to refer a specific triangle or tetrahedron.

Copy Semantics

Value. To learn how value classes affect copy operations, see [Copying Objects in the MATLAB documentation](#).

Examples

2-D Delaunay Triangulation

Create a 2-D `delaunayTriangulation` for 30 random points.

```
P = gallery('uniformdata',[30 2],0);  
DT = delaunayTriangulation(P)
```

```
DT =
```

```
delaunayTriangulation with properties:
```

```
    Points: [30x2 double]  
ConnectivityList: [50x3 double]  
    Constraints: []
```

Plot the triangulation.

delaunayTriangulation

```
figure  
triplot(DT)
```

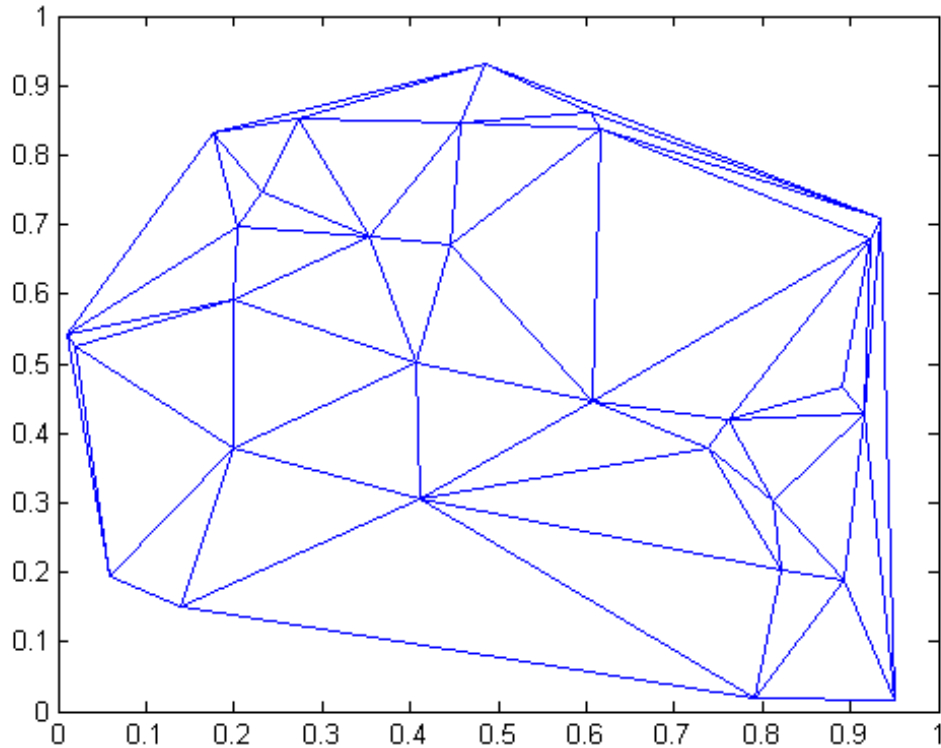

3-D Delaunay Triangulation

Create a 3-D delaunayTriangulation for 30 random points.

```
x = gallery('uniformdata',[30 1],0);  
y = gallery('uniformdata',[30 1],1);  
z = gallery('uniformdata',[30 1],2);
```



```
DT = delaunayTriangulation(x,y,z)
```

```
DT =
```

```
delaunayTriangulation with properties:
```

```
    Points: [30x3 double]  
ConnectivityList: [111x4 double]  
    Constraints: []
```

Plot the triangulation at 30% opacity with a light blue face color.

```
faceColor = [0.6875 0.8750 0.8984];  
figure  
tetramesh(DT, 'FaceColor', faceColor, 'FaceAlpha', 0.3);
```

delaunayTriangulation

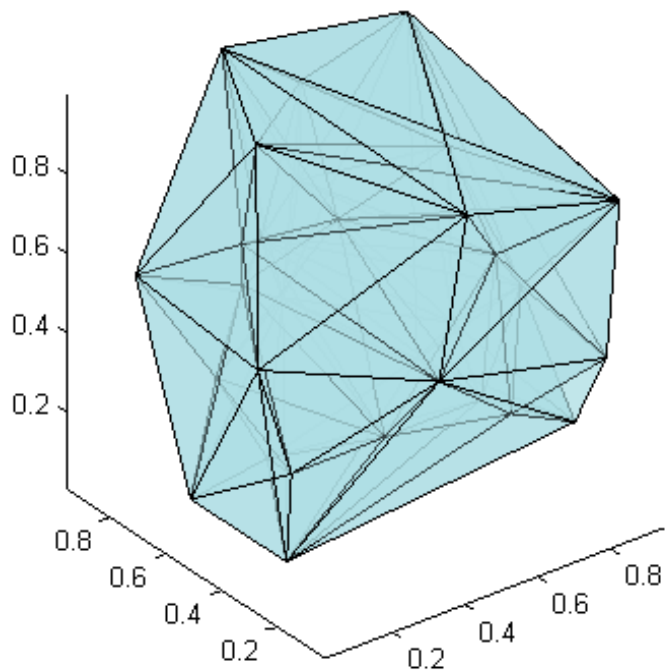

See Also

[triangulation](#) | [delaunay](#) | [delaunayn](#) |

Purpose	Convex hull
Syntax	$K = \text{convexHull}(DT)$ $[K,v] = \text{convexHull}(DT)$
Description	$K = \text{convexHull}(DT)$ returns the vertices of the convex hull. $[K,v] = \text{convexHull}(DT)$ also returns the area or volume bounded by the convex hull.
Input Arguments	DT A Delaunay triangulation, see <code>delaunayTriangulation</code> .
Output Arguments	K Convex hull vertices, returned as a matrix of vertex IDs. The shape of K depends on whether your triangulation is 2-D or 3-D: <ul style="list-style-type: none">• When DT is 2-D, K is a column vector containing the sequence of vertex IDs around the convex hull.• When DT is 3-D, K is a triangulation connectivity list containing the triangles on the convex hull.
	v Area or volume bounded by the convex hull, returned as a scalar value.
Definitions	Vertex ID A row number of the matrix, <code>DT.Points</code> . Use this ID to refer a specific vertex in the triangulation.
Examples	Convex Hull in 2-D Space Create a Delaunay triangulation from a set of random points.

delaunayTriangulation.convexHull

```
x = gallery('uniformdata',[10,1],0);  
y = gallery('uniformdata',[10,1],1);  
DT = delaunayTriangulation(x,y);
```

Calculate the convex hull.

```
k = convexHull(DT)
```

```
k =
```

```
1  
3  
2  
8  
9  
1
```

Plot the points and highlight the convex hull in red.

```
plot(DT.Points(:,1),DT.Points(:,2), '.','markersize',10);  
hold on;  
plot(DT.Points(k,1),DT.Points(k,2), 'r');  
hold off;
```

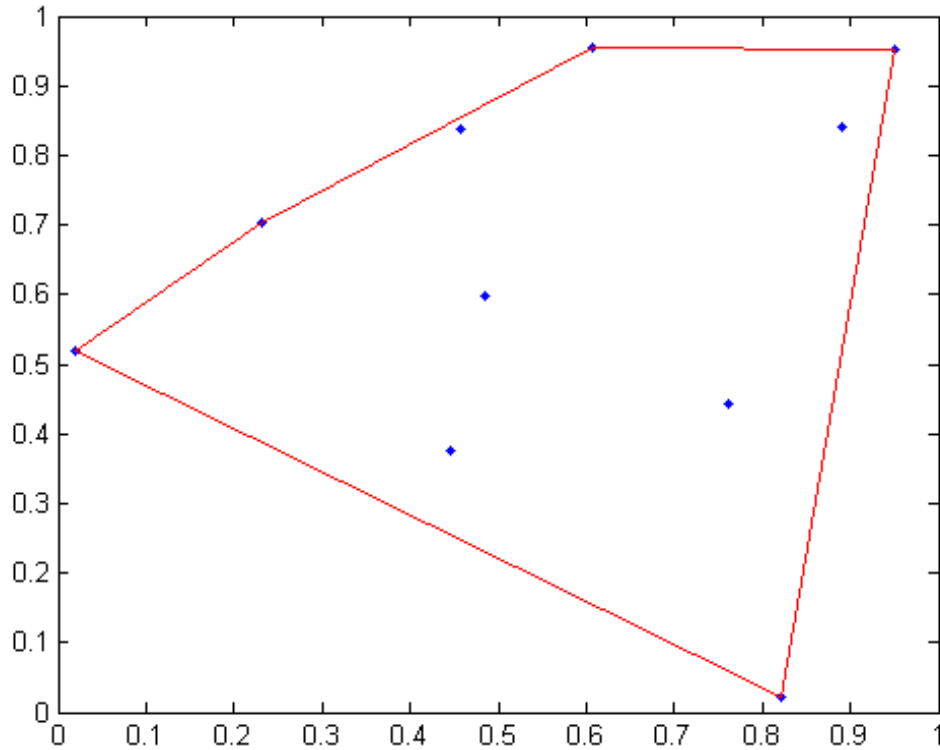

Convex Hull in 3-D Space

Use `convexHull` to calculate the convex hull of a set of random points within a unit cube.

Create a Delaunay triangulation from a set of random points.

```
P = gallery('uniformdata',[25,3],1);  
DT = delaunayTriangulation(P);
```

del aunayTriangulation.convexHull

Calculate the convex hull and the volume bounded by the convex hull.

```
[K,v] = convexHull(DT);
```

Examine the volume.

```
v
```

```
v =
```

```
0.3561
```

Plot the convex hull.

```
trisurf(K,DT.Points(:,1),DT.Points(:,2),DT.Points(:,3),...  
        'FaceColor','cyan')
```

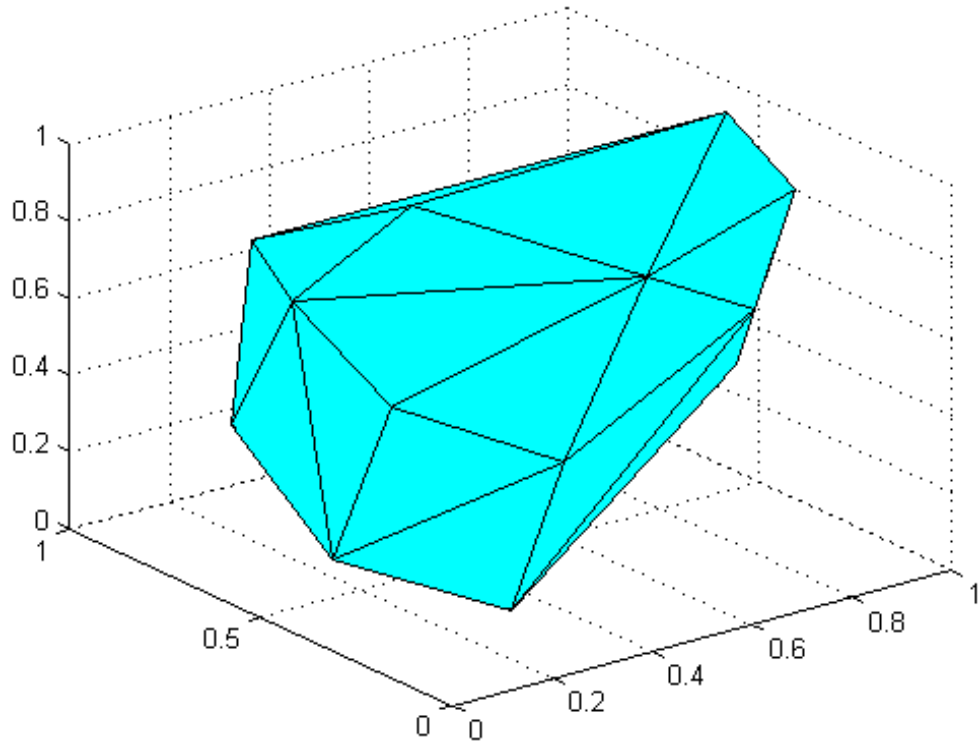

See Also

[triangulation](#) | [convhulln](#) | [convhull](#) | [voronoiDiagram](#)

delaunayTriangulation.isInterior

Purpose Test if triangle is in interior of 2-D constrained Delaunay triangulation

Syntax `tf = isInterior(DT)`

Description `tf = isInterior(DT)` returns an array of logical values that indicate whether the triangles in a constrained Delaunay triangulation are inside the bounded geometric domain. A triangle, `DT.ConnectivityList(j, :)`, is classified as inside the domain when `tf(j)` is true. Otherwise, the triangle is outside the domain.

Input Arguments **DT**
A 2-D `delaunayTriangulation` that has a set of constrained edges that define a bounded geometric domain.

Output Arguments **tf**
Logical values, returned as a column vector. Element `tf(j)` is true when the triangle whose ID is `j` is inside the domain of `DT`.

Definitions **Triangle ID**
A row number of the matrix, `DT.ConnectivityList`. You use this ID to refer a specific triangle.

Examples **Find and Plot Triangles within a Boundary**

Create a geometric domain whose shape is a square frame.

```
outerprofile = [-5 -5; -3 -5; -1 -5; 1 -5;  
               3 -5; 5 -5; 5 -3; 5 -1;  
               5 1; 5 3; 5 5; 3 5;  
               1 5; -1 5; -3 5; -5 5;  
               -5 3; -5 1; -5 -1; -5 -3];
```

```
innerprofile = outerprofile.*0.5;  
profile = [outerprofile; innerprofile];
```

Define the edge constraints.

```
outercons = [(1:19)' (2:20)'; 20 1;];  
innercons = [(21:39)' (22:40)'; 40 21];  
C = [outercons; innercons];
```

Create the constrained Delaunay triangulation.

```
DT = delaunayTriangulation(profile,C);
```

Plot the triangulation.

```
subplot(1,2,1);  
triplot(DT);
```

```
% Highlight the inner square in red.
```

```
hold on;  
plot(DT.Points(innercons',1),DT.Points(innercons',2),...  
      '-r','LineWidth',2);
```

```
% Highlight the outer square in red and resize the |x| and |y| axes to  
% the plot square.
```

```
plot(DT.Points(outercons',1),DT.Points(outercons',2), ...  
      '-r','LineWidth', 2);  
axis equal;
```

```
% Plot only the triangles that lie inside of the domain.
```

```
hold off;  
subplot(1,2,2);  
inside = isInterior(DT);  
triplot(DT.ConnectivityList(inside, :),DT.Points(:,1),DT.Points(:,2));
```

```
% Highlight the inner and outer squares in red.
```

```
hold on;  
plot(DT.Points(outercons',1),DT.Points(outercons',2), ...  
      '-r','LineWidth', 2);  
plot(DT.Points(innercons',1),DT.Points(innercons',2), ...  
      '-r','LineWidth', 2);
```

delunayTriangulation.isInterior

```
axis equal;  
hold off;
```

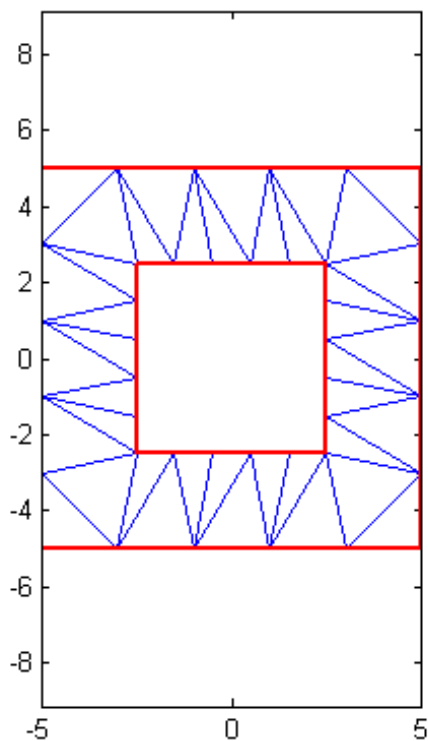
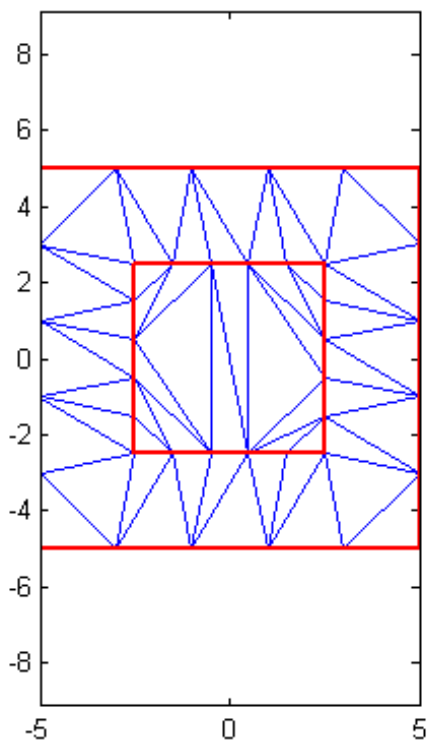

See Also [triangulation](#)

delaunayTriangulation.nearestNeighbor

Purpose

Vertex closest to specified location

Syntax

```
vi = nearestNeighbor(DT,QP)
vi = nearestNeighbor(DT,qx,qy)
vi = nearestNeighbor(DT,qx,qy,qz)
[vi,d] = nearestNeighbor( ___ )
```

Description

`vi = nearestNeighbor(DT,QP)` returns the IDs of the vertices closest to the query points in `QP`. Each row in matrix `QP` contains the x , y , (and possibly z) coordinates of a query point.

`vi = nearestNeighbor(DT,qx,qy)` specifies the x and y coordinates of the query points in 2-D as separate column vectors.

`vi = nearestNeighbor(DT,qx,qy,qz)` specifies the x , y , and z coordinates of the query points in 3-D as separate column vectors.

`[vi,d] = nearestNeighbor(___)` also returns the Euclidean distance between each query point and its nearest neighbor. You can specify both output arguments with any of the previous syntaxes.

`nearestNeighbor` does not support constrained Delaunay triangulations.

Input Arguments

DT

A Delaunay triangulation, see `delaunayTriangulation`.

QP

Query points, specified as a matrix whose columns are the x , y , (and possibly z) coordinates of the points to query.

qx

Query x -coordinates, specified as a column vector containing the x -coordinates of the points to query.

qy

Query y -coordinates, specified as a column vector containing the y -coordinates of the points to query.

delaunayTriangulation.nearestNeighbor

Output Arguments

qz

Query z -coordinates, specified as a column vector containing the z -coordinates of the points to query.

vi

Vertex IDs of nearest neighbor, returned as a column vector. $vi(j)$ is the “Vertex ID” on page 1-1682 of the nearest neighbor to the query point $QP(j)$.

d

Distance to nearest neighbor, returned as a column vector the same length as vi . Each value in d is the Euclidean distance between a query point and its nearest neighbor.

Definitions

Vertex ID

A row number of the matrix, `DT.Points`. Use this ID to refer a specific vertex in the triangulation.

Examples

Nearest Neighbors of Query Points in 2-D

Create a Delaunay triangulation from a set of random points.

```
x = gallery('uniformdata',[20 1],0);  
y = gallery('uniformdata',[20 1],1);  
DT = delaunayTriangulation(x,y);
```

Define two query points.

```
QP = [0.25 0.25; 0.5 0.5];
```

Find the nearest neighbors to the query points and the distances between them.

```
[vi,d] = nearestNeighbor(DT,QP);
```

Examine the vertex IDs of the nearest neighbors.

```
vi
```

```
vi =
```

```
    10  
     4
```

Examine the coordinates of the nearest neighbors.

```
DT.Points(vi,:)
```

```
ans =
```

```
    0.4447    0.3759  
    0.4860    0.5982
```

Examine the Euclidean distance between each query point and its nearest neighbor.

```
d
```

```
d =
```

```
    0.2319  
    0.0992
```

See Also

[triangulation](#) | [pointLocation](#)

delaunayTriangulation.pointLocation

Purpose Triangle or tetrahedron containing specified location

Syntax

```
ti = pointLocation(DT,QP)
ti = pointLocation(DT,qx,qy)
ti = pointLocation(DT,qx,qy,qz)
[ti,B] = pointLocation( __ )
```

Description

`ti = pointLocation(DT,QP)` returns the enclosing triangles or tetrahedra for each query point in `QP`. Each row in matrix `QP` contains the x , y , (and possibly z) coordinates of a query point.

`ti = pointLocation(DT,qx,qy)` specifies the x and y coordinates of the query points in 2-D as separate column vectors.

`ti = pointLocation(DT,qx,qy,qz)` specifies the x , y , z coordinates of the query points in 3-D as separate column vectors.

`[ti,B] = pointLocation(__)` also returns the barycentric coordinates of each query point with respect to its enclosing triangle or tetrahedron. You can specify both output arguments with any of the previous syntaxes.

Input Arguments

DT

A Delaunay triangulation, see `delaunayTriangulation`.

QP

Query points, specified as a matrix whose columns are the x , y , (and possibly z) coordinates of the points to query.

qx

Query x -coordinates, specified as a column vector containing the x -coordinates of the points to query.

qy

Query y -coordinates, specified as a column vector containing the y -coordinates of the points to query.

qz

Query z -coordinates, specified as a column vector containing the z -coordinates of the points to query.

Output Arguments

ti

IDs of enclosing triangles or tetrahedra, returned as a column vector. Each element in **ti** is the ID of a triangle or tetrahedron that encloses a query point. **ti(k)** encloses the k th query point.

pointLocation returns NaN values for any points outside the convex hull.

B

Barycentric coordinates, returned as matrix. The values at **B(j, :)** are the barycentric coordinates of the j th query point with respect to **ti(j)**.

Definitions

Triangle or Tetrahedron ID

A row number of the matrix, **DT.ConnectivityList**. Use this ID to refer a specific triangle or tetrahedron.

Examples

Find Enclosing Triangles in 2-D

Create a Delaunay triangulation from a set of random points.

```
x = gallery('uniformdata',[20 1],0);  
y = gallery('uniformdata',[20 1],1);  
DT = delaunayTriangulation(x,y);
```

Define two query points.

```
QP = [0.25 0.25; 0.5 0.5];
```

Find the IDs of the enclosing triangles for each query point.

```
ti = pointLocation(DT,QP)
```

```
ti =
```

delaunayTriangulation.pointLocation

```
8  
7
```

Examine the connectivity of the enclosing triangles.

```
DT.ConnectivityList(ti,:)
```

```
ans =
```

```
19    15    8  
4     10    6
```

Find Enclosing Tetrahedra and Barycentric Coordinates in 3-D

Create a 3-D Delaunay triangulation from a set of random points.

```
x = gallery('uniformdata',[20 1],0);  
y = gallery('uniformdata',[20 1],1);  
z = gallery('uniformdata',[20 1],2);  
DT = delaunayTriangulation(x,y,z);
```

Find the tetrahedra that enclose the query points and calculate the barycentric coordinates of the query points.

```
QP = [0.7 0.6 0.3; 0.5 0.5 0.5];  
[ti,B] = pointLocation(DT,QP)
```

```
ti =
```

```
57  
56
```

```
B =
```

```
0.2796    0.0184    0.5286    0.1734  
0.3687    0.0149    0.5343    0.0821
```

See Also `triangulation | nearestNeighbor`

delaunayTriangulation.voronoiDiagram

Purpose Voronoi diagram

Syntax `[V,R] = voronoiDiagram(DT)`

Description `[V,R] = voronoiDiagram(DT)` returns the Voronoi vertices, `V`, and the Voronoi regions, `R`, of the points, `DT.Points`.

The *Voronoi diagram* of a set of points, such as `DT.Points`, decomposes the space around each point, `DT.Points(j,:)`, into a region of influence, `R{j}`. Locations within the region, `R{j}`, are closer to point `j` than any other point in `DT.Points`. The region of influence is called the *Voronoi region*. The collection of all the Voronoi regions is the Voronoi diagram.

The Voronoi regions associated with points that lie on the convex hull of `DT.Points` are unbounded. Bounding edges of these regions radiate to infinity. The vertex at infinity is represented by the first vertex in `V`.

Input Arguments

DT
A Delaunay triangulation, see `delaunayTriangulation`.

Output Arguments

V
Voronoi vertices, returned as a matrix. Each row of `V` contains the coordinates of a Voronoi vertex.

R
Voronoi regions, returned as a vector cell array the same length as `DT.Points`. The elements of `R` are row numbers of `V`. The coordinates of the Voronoi vertices bounding a region are `V(R{j},:)`. The Voronoi region associated with the point `DT.Points(j)` is `R{j}`.

Examples

Compute the Voronoi Diagram of a 2-D Triangulation

Create a Delaunay triangulation from a set of points.

```
P = [ 0.5    0
      0     0.5
```

delaunayTriangulation.voronoiDiagram

```
        -0.5  -0.5  
        -0.2  -0.1  
        -0.1   0.1  
         0.1  -0.1  
         0.1   0.1 ];  
DT = delaunayTriangulation(P);
```

Calculate the Voronoi vertices and regions.

```
[V,R] = voronoiDiagram(DT);
```

Examine the connectivity of the Voronoi region associated with the third point in the triangulation.

```
R{3}
```

```
ans =
```

```
     1     10     7     4
```

Examine the coordinates of the Voronoi vertices bounding the region.

```
V(R{3},:)
```

```
ans =
```

```
      Inf      Inf  
    0.7000   -1.6500  
   -0.0500   -0.5250  
   -1.7500    0.7500
```

The Inf values indicate that the region contains points on the convex hull.

See Also

[triangulation](#) | [convexHull](#) | [voronoi](#) | [voronoin](#)

delete

Purpose Remove files or objects

Syntax

```
delete('fileName1', 'filename2', ...)  
delete(h)  
delete(handle_array)  
delete fileName
```

Description

`delete('fileName1', 'filename2', ...)` deletes the files `fileName1`, `fileName2`, and so on, from the disk. `fileName` is a string and can be an absolute path or a path relative to the current folder. `fileName` also can include wildcards (*).

`delete(h)` deletes the graphics object with handle `h`. `h` can also be a vector or matrix of handles. Delete multiple objects by appending their handles as additional arguments, separated by commas. The function deletes objects without requesting verification, even if when they are windows.

`delete(handle_array)` is a method of the `handle` class. It removes from memory the handle objects referenced by `handle_array`.

When deleted, any references to the objects in `handle_array` become invalid. To remove the handle variables, use the `clear` function.

`delete fileName` is the command syntax. Delete multiple files by appending filenames, separated by spaces. When filenames contain space characters, you must use the functional form.

As `delete` does not ask for confirmation, to avoid accidentally losing files or graphics objects, make sure to specify accurately the items to delete. To move files to a different location when running `delete`, use the **General** preference for **Deleting files**, or the `recycle` function.

The `delete` function deletes files and graphics objects only. To delete folders, use `rmdir`.

Examples Delete all files with a `.mat` extension in the `../mytests/` folder:

```
delete('../mytests/*.mat')
```

Create a figure and an axes, and then delete the axes:

```
hf = figure, ha = axes
```

```
hf =  
    1
```

```
ha =  
    170.0332
```

```
delete(ha)
```

The axes is deleted, but the figure remain. The axes handle `ha` remains in the workspace but no longer points to an object.

See Also

`dir` | `recycle` | `rmdir`

How To

-
- “Specify File Names”
- “Deleted Handle Objects”

delete (COM)

Purpose Remove COM control or server

Syntax h.delete
delete(h)

Description h.delete releases all interfaces derived from the specified COM server or control, and then deletes the server or control itself. This is different from releasing an interface, which releases and invalidates only that interface.

delete(h) is an alternate syntax.

Tips COM functions are available on Microsoft Windows systems only.

See Also release | save (COM) | load (COM) | actxcontrol | actxserver

Purpose Remove file on FTP server

Syntax `delete(ftpobj, filename)`

Description `delete(ftpobj, filename)` removes the specified file from the current folder on the FTP server associated with `ftpobj`.

Input Arguments

ftpobj
FTP object created by `ftp`.

filename
String enclosed in single quotation marks that specifies the name of the file to delete.

Examples Suppose that a hypothetical host, `ftp.testsite.com`, contains `myfile.m`. Connect to the server and delete the file:

```
test=ftp('ftp.testsite.com');  
delete(test, 'myfile.m');
```

See Also `rmdir` | `ftp`

delete (handle)

Purpose Handle object destructor

Syntax `delete(h)`

Description `delete(h)` deletes a handle object, but does not clear the handle variable from the workspace. The handle variable is not valid once the handle object has been deleted.

A subclass of `handle` can implement a method named `delete` to perform cleanup tasks just before MATLAB destroys the handle object. MATLAB calls the `delete` method of any handle object (if it exists) when the object is destroyed. `h` is a scalar handle object.

A `delete` method should not generate errors or create new handles to the object being destroyed. If the `delete` method has a different signature (having output arguments or more than one input argument) it is not called when the handle objects is destroyed. See “Handle Class Destructor” information on defining destructors for `handle` subclasses.

See Also `handle` | `(handle) isvalid`

Purpose Remove serial port object from memory

Syntax `delete(obj)`

Description `delete(obj)` removes `obj` from memory, where `obj` is a serial port object or an array of serial port objects.

Tips When you delete `obj`, it becomes an *invalid* object. Because you cannot connect an invalid serial port object to the device, you should remove it from the workspace with the `clear` command. If multiple references to `obj` exist in the workspace, then deleting one reference invalidates the remaining references.

If `obj` is connected to the device, it has a `Status` property value of `open`. If you issue `delete` while `obj` is connected, then the connection is automatically broken. You can also disconnect `obj` from the device with the `fclose` function.

Examples This example creates the serial port object `s` on a Windows platform, connects `s` to the device, writes and reads text data, disconnects `s` from the device, removes `s` from memory using `delete`, and then removes `s` from the workspace using `clear`.

```
s = serial('COM1');  
fopen(s)  
fprintf(s, '*IDN?')  
idn = fscanf(s);  
fclose(s)  
delete(s)  
clear s
```

See Also `clear` | `fclose` | `isvalid` | `Status`

deleteproperty

Purpose Remove custom property from COM object

Syntax `h.deleteproperty('propertyname')`
`deleteproperty(h,'propertyname')`

Description `h.deleteproperty('propertyname')` deletes the property specified in the string `propertyname` from the custom properties belonging to object or interface `h`.

`deleteproperty(h,'propertyname')` is an alternate syntax.

You can only delete properties created with the `addproperty` function.

COM functions are available on Microsoft Windows systems only.

Examples Remove a custom property from an instance of the MATLAB sample control:

1 Create an instance of the control:

```
f = figure('position', [100 200 200 200]);
h = actxcontrol('mwsamp.mwsampctrl.2', [0 0 200 200], f);
h.get
```

MATLAB displays its properties:

```
Label: 'Label'
Radius: 20
```

2 Add a custom property named `Position` and assign a value:

```
h.addproperty('Position');
h.Position = [200 120];
h.get
```

MATLAB displays (in part):

```
Label: 'Label'
Radius: 20
```

```
Position: [200 120]
```

3 Delete the custom property Position:

```
h.deleteproperty('Position');  
h.get
```

MATLAB displays the original list of properties:

```
Label: 'Label'  
Radius: 20
```

See Also

[addproperty](#) | [get \(COM\)](#) | [set \(COM\)](#) | [inspect](#)

delevent

Purpose Remove `tsdata.event` objects from `timeseries` object

Syntax

```
ts = delevent(ts,event)
ts = delevent(ts,events)
ts = delevent(ts,event,n)
```

Description

`ts = delevent(ts,event)` removes the `tsdata.event` object from the `ts.events` property, where `event` is an event name string.

`ts = delevent(ts,events)` removes the `tsdata.event` object from the `ts.events` property, where `events` is a cell array of event name strings.

`ts = delevent(ts,event,n)` removes the `n`th `tsdata.event` object from the `ts.events` property. `event` is the name of the `tsdata.event` object.

Examples The following example shows how to remove an event from a `timeseries` object:

1 Create a time series.

```
ts = timeseries(rand(5,4))
```

2 Create an event object called 'test' such that the event occurs at time 3.

```
e = tsdata.event('test',3)
```

3 Add the event object to the time series `ts`.

```
ts = addevent(ts,e)
```

4 Remove the event object from the time series `ts`.

```
ts = delevent(ts,'test')
```

See Also `addevent` | `timeseries` | `tsdata.event`

Purpose Remove sample from tscollection object

Syntax
`tsc = delsamplefromcollection(tsc, 'Index', N)`
`tsc = delsamplefromcollection(tsc, 'Value', Time)`

Description `tsc = delsamplefromcollection(tsc, 'Index', N)` deletes samples from the `tscollection` object `tsc`. `N` specifies the indices of the `tsc` time vector that correspond to the samples you want to delete.

`tsc = delsamplefromcollection(tsc, 'Value', Time)` deletes samples from the `tscollection` object `tsc`. `Time` specifies the time values that correspond to the samples you want to delete.

See Also `addsampletocollection` | `tscollection`

demo

Purpose Access product examples in Help browser

Syntax
demo
demo type
demo type name

Description demo displays the list of MATLAB examples in the Help browser.

demo type lists the examples for the specified product. Valid values for type are matlab or simulink.

demo type name lists the examples for products other than MATLAB or Simulink. Valid values for type include matlab, simulink, toolbox, or blockset.

Input Arguments

type - Product name or type
matlab (default) | simulink | toolbox | blockset

Product name or type, specified as one of these strings: matlab, simulink, toolbox, or blockset. For products other than MATLAB or Simulink, you must also specify a name input that corresponds to the product name.

name - Product name other than MATLAB or Simulink
string

Product name other than MATLAB or Simulink, specified as a string. If name requires multiple words, enclose it in single quotes.

On non-English systems, name sometimes uses the localized language.

Examples

MATLAB Examples

```
demo matlab
```

Statistics Toolbox™ Examples

```
demo toolbox statistics
```

Communications System Toolbox™ Examples

```
demo toolbox 'communications system'
```

Simulink Control Design™ Examples

```
demo simulink 'simulink control design'
```

Tips

- To access third-party and custom examples without using the demo command, open the Help browser and navigate to the documentation home page. Then, at the bottom of the page, click **Supplemental Software**.

See Also

[echodemo](#) | [grabcode](#) | [help](#) | [doc](#)

depdir

Purpose

List dependent folders for function or P-file

Note `depdir` will be removed in a future release. Use `matlab.codetools.requiredFilesAndProducts` instead.

Syntax

```
list = depdir('file_name')  
[list, prob_files, prob_sym, prob_strings] = depdir('file_name')  
[...] = depdir('file_name1', 'file_name2',...)
```

Description

The `depdir` function lists the folders of all the functions that a specified function or P-file needs to operate. This function is useful for finding all the folders that need to be included with a run-time application and for determining the run-time path.

`list = depdir('file_name')` creates a cell array of strings containing the folders of all the function and P-files that `file_name.m` or `file_name.p` uses. This includes the second-level files that are called directly by `file_name`, as well as the third-level files that are called by the second-level files, and so on.

`[list, prob_files, prob_sym, prob_strings] = depdir('file_name')` creates three additional cell arrays containing information about any problems with the `depdir` search. `prob_files` contains filenames that `depdir` was unable to parse. `prob_sym` contains symbols that `depdir` was unable to find. `prob_strings` contains callback strings that `depdir` was unable to parse.

`[...] = depdir('file_name1', 'file_name2',...)` performs the same operation for multiple files. The dependent folders of all files are listed together in the output cell arrays.

Examples

```
list = depdir('mesh')
```

See Also

`matlab.codetools.requiredFilesAndProducts`

- Purpose** List dependencies of function or P-file
- Compatibility** depfun will be removed in a future release. Use `matlab.codetools.requiredFilesAndProducts` instead.
- Syntax**
- ```
list = depfun(fun)
[list,builtins] = depfun(fun)
[list,builtins,classes] = depfun(fun)
[list,builtins,classes,prob_files] = depfun(fun)
[list,builtins,classes,prob_files,~,eval_strings]
= depfun(fun)
[list,builtins,classes,prob_files,~,eval_strings,
called_from] = depfun(fun)
[list,builtins,classes,prob_files,~,eval_strings,called_from,
opaque_classes] = depfun(fun)

___ = depfun(fun1,...,funN)

___ = depfun(___,option1,...,optionM)
```
- Description** `list = depfun(fun)` returns the paths of MATLAB program files that `fun` requires to run, where `fun` is a function, a P-file, or a figure file for a user interface. The output `list` includes second-level functions that `fun` calls directly, functions that the second-level functions call, and so on. The `depfun` function also displays a report in the Command Window.

---

**Note**

- `depfun` does not always list all dependent files. For example, `depfun` does not list files hidden in callbacks or files whose names are constructed dynamically for evaluation.
  - The output list often includes extra files that are not called when the function is actually evaluated.
  - If `depfun` returns a parse error for any of the required functions, then the rest of the output of `depfun` might be incomplete. Correct the problematic files and invoke `depfun` again.
- 

`[list,builtins] = depfun(fun)` returns the built-in functions that `fun` requires.

`[list,builtins,classes] = depfun(fun)` returns the MATLAB classes that `fun` requires.

`[list,builtins,classes,prob_files] = depfun(fun)` returns the files that `depfun` cannot parse, find, or access. If there are problematic files (that is, if `prob_files` is not empty), then the rest of the output of `depfun` might be incomplete. Correct the problematic files, and then invoke `depfun` again.

`[list,builtins,classes,prob_files,~,eval_strings] = depfun(fun)` returns a list of files that contain calls to `eval` or related functions (`evalin`, `feval`, or `evalc`). These calls potentially use functions that are not in `list`.

The fifth output argument for `depfun` is not implemented, and returns an empty structure array. To request arguments later in the list, use the tilde symbol (`~`) as a placeholder. The tilde suppresses the creation of an extra, empty variable.

`[list,builtins,classes,prob_files,~,eval_strings,called_from] = depfun(fun)` returns a cell array of indices that maps each function in `list` to the set of functions that call it. That is, `list{called_from{k}}` returns the paths to the functions that call the function in `list{k}`.

`[list,builtins,classes,prob_files,~,eval_strings,called_from,opaque_classes] = depfun(fun)` returns the opaque classes that `fun` requires, such as Java or COM classes.

`___ = depfun(fun1,...,funN)` returns the functions required for multiple functions `fun1,...,funN`. You can request any of the outputs from the previous syntaxes.

`___ = depfun(___,option1,...,optionM)` modifies the output as described by the specified options. For example, specify `'-toponly'` to list only the functions that `fun` calls directly. You can precede the options with one or more function names.

## Input Arguments

### **fun - Function name**

string | cell array of strings

Function name, specified as a string or a cell array of strings.

`fun` must be on the MATLAB path, as determined by the `which` function. If the path contains any relative folders, then files in those folders also will have a relative path in the output.

**Example:** `'plot.m'`

**Example:** `'plot.m','mesh.m'`

**Example:** `{'plot.m','mesh.m'}`

### **Data Types**

char | cell

### **option - Reporting option**

'-toponly' | '-verbose' | '-quiet' | '-print' | ...

Reporting option, specified as one of the following strings.

| Option             | Description                                                                                                                                                                              |
|--------------------|------------------------------------------------------------------------------------------------------------------------------------------------------------------------------------------|
| '-toponly'         | Identify only the files used directly by the specified function(s), fun.                                                                                                                 |
| '-verbose'         | Display additional internal messages.                                                                                                                                                    |
| '-quiet'           | Display only error and warning messages, and not a summary report.                                                                                                                       |
| '-print', filename | Print a full report to the specified file.                                                                                                                                               |
| '-all'             | Display all outputs in the report, but return only the specified output arguments.                                                                                                       |
| '-expand'          | Include both indices and full paths in an exported report for the call or called_from list. Requires the '-print' option. This information does not appear in the Command Window report. |
| '-calltree'        | Replaces the called_from list with a list of functions that each file calls, as derived from the called_from list.                                                                       |

**Example:** '-print', 'myreport.txt'

## Data Types

char

## Output Arguments

### list - Paths to required files

cell array of strings

Paths to required files, returned as a cell array of strings.

### builtins - Required MATLAB built-in functions

cell array of strings

Required MATLAB built-in functions, returned as a cell array of strings.

**classes - Required MATLAB classes**

cell array of strings

Required MATLAB classes, returned as a cell array of strings.

**prob\_files - Files that depfun cannot parse or access**

structure

Files that depfun cannot parse or access, returned as a structure with these fields:

- `name` — Path to the file
- `listindex` — Index of the file in `list`
- `errmsg` — Error message that describes the problem
- `errid` — Error identifier, if present

**eval\_strings - Files that call evaluation functions**

cell array of strings

Files that call evaluation functions, returned as a cell array of strings.

**called\_from - Indices to files that call each function in list**

cell array

Indices to files that call each function in `list`, returned as a cell array. Each element of the cell array is a numeric array of indices that correspond to elements in `list`. The `list` and `called_from` outputs have the same length.

**opaque\_classes - Paths to opaque classes**

cell array of strings

Paths to opaque classes, such as Java or COM classes, returned as a cell array of strings.

**Examples****Identify Required Functions**

Identify the MATLAB program files that `strtok.m` requires to run.

```
fun = 'strtok.m';
list = depfun(fun);
```

MATLAB displays a summary report in the Command Window and stores the list of files in variable `list`.

## Identify Top-Level Dependencies Only

List only the program files that `strtok.m` calls directly.

```
fun = 'strtok.m';
list = depfun(fun, '-toponly')
```

```
=====
depfun report summary:(top only)

-> trace list: 2 files (total)
 1 files (total arguments)
 0 files (arguments off MATLABPATH)
 0 files (argument duplicates on MATLABPATH)

Notes: 1. Use argument '-quiet' to not print this summary.
 2. Use arguments '-print','file' to produce a full
 report in file.
 3. Use argument '-all' to display all possible
 left hand side arguments in the report(s).
=====
```

```
list =

 'matlabroot\toolbox\matlab\strfun\strtok.m'
 'matlabroot\toolbox\matlab\strfun\@cell\strtok.m'
```

## Determine Which File Invokes Each Function

One of the functions that `strtok.m` depends upon is `num2cell`. Determine which file in the dependency list calls `num2cell`.

Identify the functions that `strtok.m` requires (`list`) and the files that invoke each of those functions (`called_from`).

```
fun = 'strtok.m';
[list,builtins,classes,prob_files,~,eval_strings,...
 called_from] = depfun(fun);
```

Find the index for `num2cell` within the dependency list.

```
num2cell_path = which('num2cell');
num2cell_index = find(ismember(list,num2cell_path))
```

```
num2cell_index =
 5
```

Identify the file that calls `num2cell`.

```
calls_num2cell = list{called_from{num2cell_index}}
```

```
calls_num2cell =
 matlabroot\toolbox\matlab\elmat\repmat.m
```

## Concepts

- “Identify Program Dependencies”

# det

---

**Purpose** Matrix determinant

**Syntax** `d = det(X)`

**Description** `d = det(X)` returns the determinant of the square matrix `X`.

**Tips** Testing singularity using `abs(det(X)) <= tolerance` is not recommended as it is difficult to choose the correct tolerance. The function `cond(X)` can check for singular and nearly singular matrices.

**Algorithms** The determinant is computed from the triangular factors obtained by Gaussian elimination

```
[L,U] = lu(A)
s = det(L) % This is always +1 or -1
det(A) = s*prod(diag(U))
```

**Examples** The statement `A = [1 2 3; 4 5 6; 7 8 9]` produces

```
A =
 1 2 3
 4 5 6
 7 8 9
```

This happens to be a singular matrix, so `det(A)` produces a very small number. Changing `A(3,3)` with `A(3,3) = 0` turns `A` into a nonsingular matrix. Now `d = det(A)` produces `d = 27`.

**See Also** `cond` | `condest` | `inv` | `lu` | `rref` | `mldivide`



|                        |                                                                                                                                                                                                                                                                                                                                                                                                                                                                                                                                                                                                                                                                                                                                                                          |
|------------------------|--------------------------------------------------------------------------------------------------------------------------------------------------------------------------------------------------------------------------------------------------------------------------------------------------------------------------------------------------------------------------------------------------------------------------------------------------------------------------------------------------------------------------------------------------------------------------------------------------------------------------------------------------------------------------------------------------------------------------------------------------------------------------|
| <b>Purpose</b>         | Display array details                                                                                                                                                                                                                                                                                                                                                                                                                                                                                                                                                                                                                                                                                                                                                    |
| <b>Syntax</b>          | <code>details(A)</code>                                                                                                                                                                                                                                                                                                                                                                                                                                                                                                                                                                                                                                                                                                                                                  |
| <b>Description</b>     | <p><code>details(A)</code> displays detailed information about the array, <code>A</code>.</p> <p>When <code>A</code> is a MATLAB object array, <code>details</code> displays more information than the default display. This information includes:</p> <ul style="list-style-type: none"> <li>• Fully qualified class name, including package names</li> <li>• Link to class documentation</li> <li>• Link to <code>handle</code> class documentation for classes that subclass <code>handle</code></li> <li>• List of all properties that have public get access</li> <li>• List of property values if the array is scalar</li> <li>• Link to list of public methods</li> <li>• Link to list of events</li> <li>• Link to list of all nonhidden superclasses</li> </ul> |
| <b>Input Arguments</b> | <p><b>A - Input array</b><br/> <i>scalar or nonscalar array of any type</i></p> <p>Input array, specified as a scalar or nonscalar array of any type. The <code>details</code> function displays detailed information about this array.</p>                                                                                                                                                                                                                                                                                                                                                                                                                                                                                                                              |
| <b>Examples</b>        | <p><b>Display Object Details</b></p> <p>Display object details for a class that overloads its own object display. The <code>details</code> function never calls overloaded display methods. Therefore, you can use this function to obtain information about the object array in all cases.</p> <p>Suppose <code>PolyNom</code> is a class that provides a specialized default display for polynomials. Use <code>details</code> to display information about the object.</p> <p>Create an object using the polynomial coefficients:</p>                                                                                                                                                                                                                                 |

# details

---

```
pn = PolyNom([1,2,3,0,4])
```

The overloaded `disp` method displays the code for evaluating the polynomial:

```
pn =
x^4 + 2*x^3 + 3*x^2 + 4
```

Calling the `details` function provides information about the object:

```
details(pn)
```

`PolyNom` with properties:

```
coef: [1 2 3 0 4]
```

`Methods`

## See Also

`classdef` | `disp` | `display`

**Purpose** Remove linear trends

**Syntax**

```
y = detrend(x)
y = detrend(x, 'constant')
y = detrend(x, 'linear', bp)
```

**Description** `detrend` removes the mean value or linear trend from a vector or matrix, usually for FFT processing.

`y = detrend(x)` removes the best straight-line fit from vector `x` and returns it in `y`. If `x` is a matrix, `detrend` removes the trend from each column.

`y = detrend(x, 'constant')` removes the mean value from vector `x` or, if `x` is a matrix, from each column of the matrix.

`y = detrend(x, 'linear', bp)` removes a continuous, piecewise linear trend from vector `x` or, if `x` is a matrix, from each column of the matrix. Vector `bp` contains the indices of the breakpoints between adjacent linear segments. The breakpoint between two segments is defined as the data point that the two segments share.

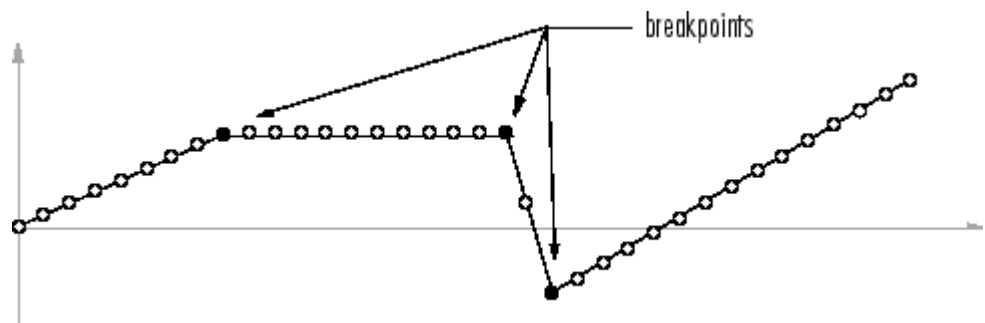

`detrend(x, 'linear')`, with no breakpoint vector specified, is the same as `detrend(x)`.

## Examples

```
sig = [0 1 -2 1 0 1 -2 1 0]; % signal with no linear trend
trend = [0 1 2 3 4 3 2 1 0]; % two-segment linear trend
```

# detrend

---

```
x = sig+trend; % signal with added trend
y = detrend(x, 'linear',5) % breakpoint at 5th element

y =

-0.0000
 1.0000
-2.0000
 1.0000
 0.0000
 1.0000
-2.0000
 1.0000
-0.0000
```

Note that the breakpoint is specified to be the fifth element, which is the data point shared by the two segments.

## Algorithms

detrend computes the least-squares fit of a straight line (or composite line for piecewise linear trends) to the data and subtracts the resulting function from the data. To obtain the equation of the straight-line fit, use `polyfit`.

## See Also

`polyfit`

**Purpose** Evaluate solution of differential equation problem

**Syntax**

```
sxint = deval(sol,xint)
sxint = deval(xint,sol)
sxint = deval(sol,xint,idx)
sxint = deval(xint,sol,idx)
[sxint, spxint] = deval(...)
```

**Description** `sxint = deval(sol,xint)` and `sxint = deval(xint,sol)` evaluate the solution of a differential equation problem. `sol` is a structure returned by one of these solvers:

- An initial value problem solver (`ode45`, `ode23`, `ode113`, `ode15s`, `ode23s`, `ode23t`, `ode23tb`, `ode15i`)
- A delay differential equations solver (`dde23`, `ddesd`, or `ddensd`),
- A boundary value problem solver (`bvp4c` or `bvp5c`).

`xint` is a point or a vector of points at which you want the solution. The elements of `xint` must be in the interval `[sol.x(1),sol.x(end)]`. For each `i`, `sxint(:,i)` is the solution at `xint(i)`.

`sxint = deval(sol,xint,idx)` and `sxint = deval(xint,sol,idx)` evaluate as above but return only the solution components with indices listed in the vector `idx`.

`[sxint, spxint] = deval(...)` also returns `spxint`, the value of the first derivative of the polynomial interpolating the solution.

---

**Note** For multipoint boundary value problems, the solution obtained by `bvp4c` or `bvp5c` might be discontinuous at the interfaces. For an interface point `xc`, `deval` returns the average of the limits from the left and right of `xc`. To get the limit values, set the `xint` argument of `deval` to be slightly smaller or slightly larger than `xc`.

---

## Examples

### Evaluate van der Pol Equation

This example solves the system  $y' = \text{vdp1}(t,y)$  using `ode45` and plots the first component of the solution.

Solve the system using `ode45`.

```
sol = ode45(@vdp1,[0 20],[2 0]);
```

Evaluate the first component of the solution at 100 points in the interval `[0,20]`.

```
x = linspace(0,20,100);
y = deval(sol,x,1);
```

Plot the solution.

```
plot(x,y)
```

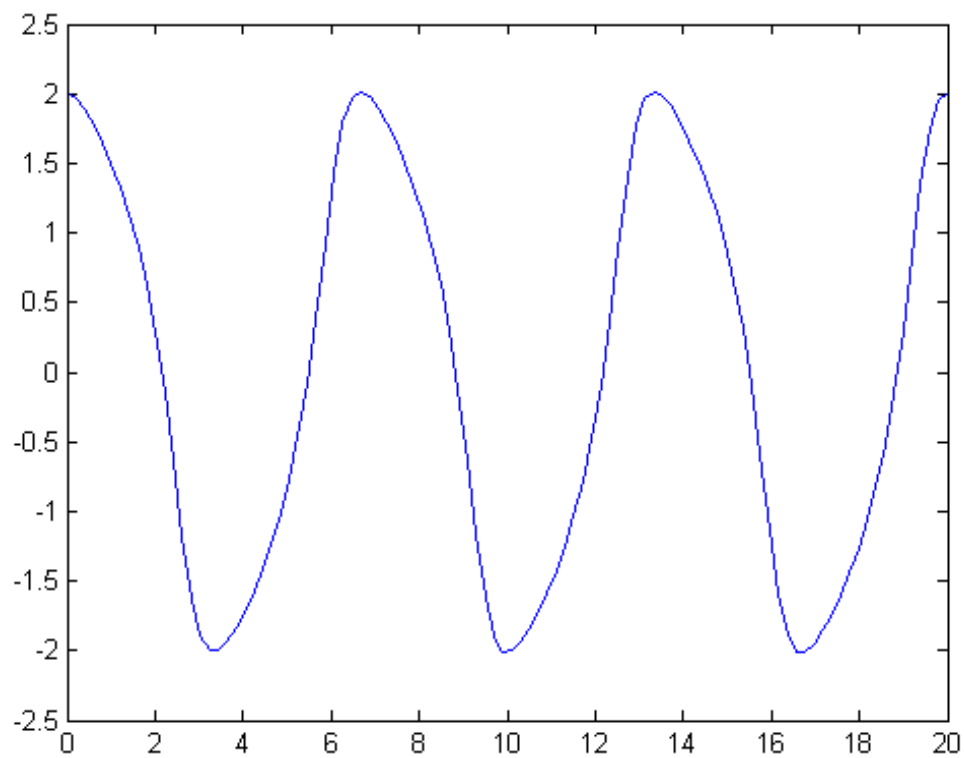
**See Also**

[ode45](#) | [ode23](#) | [ode113](#) | [ode15s](#) | [ode23s](#) | [ode23t](#) | [ode23tb](#) |  
[ode15i](#) | [dde23](#) | [ddesd](#) | [ddensd](#) | [bvp4c](#) | [bvp5c](#)

# diag

---

**Purpose** Get diagonal elements or create diagonal matrix

**Syntax**

```
D = diag(v)
D = diag(v,k)

x = diag(A)
x = diag(A,k)
```

**Description** `D = diag(v)` returns a square diagonal matrix with the elements of vector `v` on the main (`k=0`) diagonal.

`D = diag(v,k)` places the elements of vector `v` on the `k`th diagonal. `k=0` represents the main diagonal, `k>0` is above the main diagonal, and `k<0` is below the main diagonal.

`x = diag(A)` returns a column vector of the main (`k=0`) diagonal elements of `A`.

`x = diag(A,k)` returns a column vector of the elements on the `k`th diagonal of `A`.

## Input Arguments

### **v - Diagonal elements**

vector

Diagonal elements, specified as a vector. If `v` is a vector with `N` elements, then `diag(v,k)` is a square matrix of order `N+abs(k)`.

`diag([])` returns an empty matrix, `[]`.

### **Data Types**

single | double | int8 | int16 | int32 | int64 | uint8 |  
uint16 | uint32 | uint64 | logical | char

**Complex Number Support:** Yes

### **A - Input matrix**

matrix



Input matrix, specified as a matrix. `diag` returns an error if `ndims(A) > 2`.

`diag([])` returns an empty matrix, `[]`.

### Data Types

`single` | `double` | `int8` | `int16` | `int32` | `int64` | `uint8` | `uint16` | `uint32` | `uint64` | `logical` | `char`

**Complex Number Support:** Yes

### k - Diagonal number

integer

Diagonal number, specified as an integer.  $k=0$  represents the main diagonal,  $k>0$  is above the main diagonal, and  $k<0$  is below the main diagonal.

For an  $m$ -by- $n$  matrix,  $k$  is in the range  $(-m+1) \leq k \leq (n-1)$ .

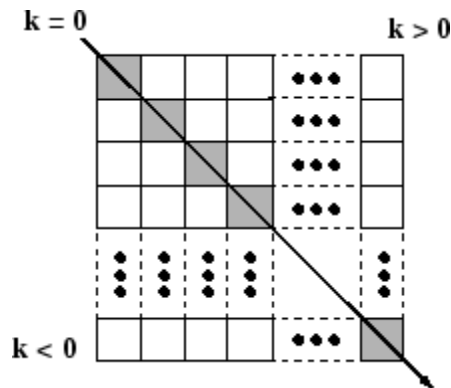

## Examples

### Create Diagonal Matrices

Define a 1-by-5 vector.

```
v = [2 1 -1 -2 -5];
```

Use `diag` to create a matrix with the elements of `v` on the main diagonal.

# diag

---

```
D = diag(v)
```

```
D =
```

```
 2 0 0 0 0
 0 1 0 0 0
 0 0 -1 0 0
 0 0 0 -2 0
 0 0 0 0 -5
```

The result is a 5-by-5 diagonal matrix.

Create a matrix with the elements of `v` on the first super diagonal (`k=1`).

```
D1 = diag(v,1)
```

```
D1 =
```

```
 0 2 0 0 0 0
 0 0 1 0 0 0
 0 0 0 -1 0 0
 0 0 0 0 -2 0
 0 0 0 0 0 -5
 0 0 0 0 0 0
```

The result is a 6-by-6 matrix. When you specify a vector of length `n` as an input, `diag` returns a square matrix of size `n+abs(k)`.

## Get Diagonal Elements

Create a random 6-by-6 matrix.

```
rng(0);
A = randi(10,6)
```

```
A =
```

```
 9 3 10 8 7 8
 10 6 5 10 8 1
```

```
 2 10 9 7 8 3
 10 10 2 1 4 1
 7 2 5 9 7 1
 1 10 10 10 2 9
```

Get the elements on the main diagonal of A.

```
x = diag(A)
```

```
x =
```

```
 9
 6
 9
 1
 7
 9
```

The result is a column vector of the elements on the main diagonal of A.

Get the elements on the first sub diagonal ( $k=-1$ ) of A.

```
x1 = diag(A, -1)
```

```
x1 =
```

```
 10
 10
 2
 9
 2
```

The result has one less element than the main diagonal.

Nest calls to `diag` to generate a new diagonal matrix from the diagonal elements.

```
A1 = diag(diag(A))
```

# diag

---

A1 =

```
 9 0 0 0 0 0
 0 6 0 0 0 0
 0 0 9 0 0 0
 0 0 0 1 0 0
 0 0 0 0 7 0
 0 0 0 0 0 9
```

The result is a square diagonal matrix with the same main diagonal elements as A.

## Tips

- When you specify a vector input, `diag` returns a square diagonal matrix. When you specify a matrix input, `diag` returns a column vector of diagonal elements.
- The trace of a matrix is equal to `sum(diag(A))`.

## See Also

`spdiags` | `tril` | `triu` | `isdiag` | `istril` | `istriu` | `blkdiag`

## Purpose

Summary of classes in MATLAB Diagnostics Interface

## Description

Use diagnostics to communicate relevant information in the event of a failure. To add a diagnostic message to a test case, use the `diagnostic` argument in any of the `matlab.unittest.qualifications` methods. The framework also displays diagnostic messages related to the nature of the qualification failure. The `matlab.unittest.diagnostics` package consists of the following classes:

`matlab.unittest.diagnostics.ConstraintDiagnostic` Diagnostic specific to `matlab.unittest.constraints`

`matlab.unittest.diagnostics.Diagnostic` Fundamental interface class for `matlab.unittest.diagnostics`

`matlab.unittest.diagnostics.DisplayDiagnostic` Diagnostic using a value's displayed output

`matlab.unittest.diagnostics.FunctionHandleDiagnostic` Diagnostic using a function's displayed output

`matlab.unittest.diagnostics.StringDiagnostic` Diagnostic using string

# matlab.unittest.diagnostics.ConstraintDiagnostic

---

**Superclasses** Diagnostic

**Purpose** Diagnostics specific to matlab.unittest constraints

**Description** The ConstraintDiagnostic class provides various textual fields that are common to most constraints. These fields may be turned on or off depending on their applicability.

The ConstraintDiagnostic class is a helper class for displaying diagnostics when using constraints. The ConstraintDiagnostic class provides custom constraint authors a way to add a common look and feel to diagnostics produced by the getDiagnosticFor method of constraints.

Constraint diagnostics are displayed in the following order: Description, Conditions, Actual Value, and Expected Value.

## Properties

### ActVal

The actual value passed to the constraint for testing.

### ActValHeader

Header information for the actual value property, ActVal, specified as a string. The default header is 'Actual Value:'.

### Conditions

Formatted list of conditions, specified as a single string. Each condition starts on a new line and begins with an arrow (-->) delimiter. Conditions are added to the list using the addCondition and addConditionsFrom methods.

### ConditionsCount

Number of conditions in the condition list. This is a read-only property generated from the conditions list. The conditions list is defined in the Conditions property.

### Description

General diagnostic information, specified as a string.

## **DisplayActVal**

Indicator whether to display the actual value property, `ActVal`, specified as a boolean. By default, the actual value is not displayed and the value of this property is `false`.

## **DisplayConditions**

Indicator of whether to display the `Conditions` property, specified as a boolean. By default, the conditions are not displayed and the value of this property is `false`. Even if `DisplayConditions` is set to `true`, if there are no conditions on the conditions list, neither the conditions header or the conditions list are displayed.

## **DisplayDescription**

Indicator of whether to display the `Description` property, specified as a boolean. By default, the description is not displayed and the value of this property is `false`.

## **DisplayExpVal**

Indicator whether to display the expected value property, `ExpVal`, specified as a boolean. By default, the expected value is not displayed and the value of this property is `false`.

## **ExpVal**

If applicable, the expected value. This property can be turned off if the associated constraint does not contain an expected value.

## **ExpValHeader**

Header information for the expected value property, `ExpVal`, specified as a string. The default header is 'Expected Value:'.

## **Inherited Properties**

### **DiagnosticResult**

The `DiagnosticResult` property provides the means by which the actual diagnostic information is communicated to consumers of

# matlab.unittest.diagnostics.ConstraintDiagnostic

---

diagnostics, such as testing frameworks. The property is a string that is defined during evaluation of the `diagnose` method.

## Methods

|                                          |                                                                                |
|------------------------------------------|--------------------------------------------------------------------------------|
| <code>addCondition</code>                | Add condition to condition list                                                |
| <code>addConditionsFrom</code>           | Add condition from another <code>ConstraintDiagnostic</code> to condition list |
| <code>getDisplayableString</code>        | Convert object to string for display                                           |
| <code>getPostActValString</code>         | Returns text to be displayed following actual value                            |
| <code>getPostConditionString</code>      | Returns text to be displayed following conditions list                         |
| <code>getPostDescriptionString</code>    | Returns text to be displayed following description                             |
| <code>getPostExpValString</code>         | Returns text to be displayed following expected value                          |
| <code>getPostPreDescriptionString</code> | Returns text to be displayed prior to description                              |

## Inherited Methods

|                       |                                               |
|-----------------------|-----------------------------------------------|
| <code>diagnose</code> | Execute diagnostic action                     |
| <code>join</code>     | Join multiple diagnostics into a single array |

## Copy Semantics

Handle. To learn how handle classes affect copy operations, see Copying Objects in the MATLAB documentation.

## See Also

`Diagnostic` | `matlab.unittest.diagnostics` | `matlab.unittest.constraints` |



## Concepts

# matlab.unittest.diagnostics.ConstraintDiagnostic.addCondition

---

**Purpose** Add condition to condition list

**Syntax** `addCondition(diag, cond)`

**Description** `addCondition(diag, cond)` adds the condition, `cond`, to the condition list. Add conditions to the condition list one at a time. When the condition list is displayed, each condition is preceded by an arrow ( - ->) delimiter and indented.

**Input Arguments**

**cond**  
Condition, specified as a string containing information specific to the cause of the constraint failure or another Diagnostic instance, which acts as a “subdiagnostic”.

**diag**  
`matlab.unittest.diagnostics.Diagnostic` instance.

**See Also** `addConditionsFrom`

# matlab.unittest.diagnostics.ConstraintDiagnostic.addCond

**Purpose** Add condition from another ConstraintDiagnostic to condition list

**Syntax** addConditionsFrom(constDiag, otherConstDiag)

**Description** addConditionsFrom(constDiag, otherConstDiag) adds the conditions from the ConstraintDiagnostic instance, constDiag, to the condition list in the Diagnostic instance, diag. This is useful when a constraints composes another constraint, and needs to use the conditions produced in the diagnostics of the composed constraint.

## Input Arguments

### constDiag

Diagnostic to add conditions to, specified as a matlab.unittest.diagnostics.ConstraintDiagnostic instance

### otherConstDiag

Diagnostic to add conditions from, specified as a matlab.unittest.diagnostics.ConstraintDiagnostic instance

## Examples

### Add Conditions from a Constraint

```
% This demonstrates a constraint that composes another constraint
% and uses the addConditionsFrom method to utilize the conditions
% from the composed ConstraintDiagnostic.
classdef IsDouble < matlab.unittest.constraints.Constraint

 properties(Constant, GetAccess=private)
 DoubConst=matlab.unittest.constraints.IsInstanceOf(?double)
 end

 methods
 function tf = satisfiedBy(constraint, actual)
 tf = constraint.DoubConst.satisfiedBy(actual);
 end
 function diag = getDiagnosticFor(constraint, actual)
```

# matlab.unittest.diagnostics.ConstraintDiagnostic.addConditions

---

```
 diag = ConstraintDiagnostic;

 % Now add conditions from the IsInstanceOf
 % Diagnostic
 otherDiag = constraint.DoubConst.getDiagnosticFor(actual);
 diag.addConditionsFrom(otherDiag);

 % ...
 end
end
end
```

**See Also** [addCondition](#)

# matlab.unittest.diagnostics.ConstraintDiagnostic.getDisplayableString

---

**Purpose** Convert object to string for display

**Syntax** `str = matlab.unittest.diagnostics.ConstraintDiagnostic.getDisplayableString(value)`

**Description** `str = matlab.unittest.diagnostics.ConstraintDiagnostic.getDisplayableString(value)` converts the object, `obj` to a string, `str` for display in a diagnostic result. This conversion determines if hotlinks should be included in the string and truncates large numeric or cell arrays.

**Input Arguments**

**value**  
Object of arbitrary class

# matlab.unittest.diagnostics.ConstraintDiagnostic.getPreDescrip

---

**Purpose** Returns text to be displayed prior to description

**Syntax** `str = getPreDescriptionString(constDiag)`

**Description** `str = getPreDescriptionString(constDiag)` returns text to be displayed prior to the description. This method can be overridden to inject strings prior to displaying the `Description` property of the `ConstraintDiagnostic`. The location of this text is tied to the `Description` property. Its placement relative to other fields is not guaranteed.

**Input Arguments**

**constDiag**  
matlab.unittest.diagnostics.ConstraintDiagnostic instance.

**See Also** `ConstraintDiagnostic` | `getPostActValString` | `getPostDescriptionString` | `getPostConditionString` | `getPostExpValString`

# matlab.unittest.diagnostics.ConstraintDiagnostic.getPostD

---

**Purpose** Returns text to be displayed following description

**Syntax** `str = getPostDescriptionString(constDiag)`

**Description** `str = getPostDescriptionString(constDiag)` returns text to be displayed following the description. This method can be overridden to inject strings subsequent to displaying the `Description` property of the `ConstraintDiagnostic`. The location of this text is tied to the `Description` property. Its placement relative to other fields is not guaranteed.

**Input Arguments**

**constDiag**  
matlab.unittest.diagnostics.ConstraintDiagnostic instance.

**See Also** `ConstraintDiagnostic` | `getPreDescriptionString` | `getPostActValString` | `getPostConditionString` | `getPostExpValString`

**Purpose** Returns text to be displayed following conditions list

**Syntax** `str = getPostConditionsString(constDiag)`

**Description** `str = getPostConditionsString(constDiag)` returns text to be displayed following the conditions list. This method can be overridden to inject strings subsequent to displaying the `Conditions` property of the `ConstraintDiagnostic`. The location of this text is tied to the `Conditions` property. Its placement relative to other fields is not guaranteed.

**Input Arguments**

**constDiag**  
matlab.unittest.diagnostics.ConstraintDiagnostic instance.

**See Also** `ConstraintDiagnostic` | `getPreDescriptionString` | `getPostDescriptionString` | `getPostActValString` | `getPostExpValString`



**Purpose** Returns text to be displayed following actual value

**Syntax** `str = getPostActualValString(constDiag)`

**Description** `str = getPostActualValString(constDiag)` returns text to be displayed following the actual value. This method can be overridden to inject strings subsequent to displaying the `ActVal` property of the `ConstraintDiagnostic`. The location of this text is tied to the `ActVal` property. Its placement relative to other fields is not guaranteed.

**Input Arguments**

**constDiag**  
matlab.unittest.diagnostics.ConstraintDiagnostic instance.

**See Also** `ConstraintDiagnostic` | `getPreDescriptionString` | `getPostDescriptionString` | `getPostConditionString` | `getPostExpValString`

**Purpose** Returns text to be displayed following expected value

**Syntax** `str = getPostExpValString(constDiag)`

**Description** `str = getPostExpValString(constDiag)` returns text to be displayed following the expected value. This method can be overridden to inject strings subsequent to displaying the `ExpVal` property of the `ConstraintDiagnostic`. The location of this text is tied to the `ExpVal` property. Its placement relative to other fields is not guaranteed.

**Input Arguments**

**constDiag**  
matlab.unittest.diagnostics.ConstraintDiagnostic instance.

**See Also** `ConstraintDiagnostic` | `getPreDescriptionString` | `getPostDescriptionString` | `getPostConditionString` | `getPostActValString`

## Purpose

Fundamental interface class for `matlab.unittest` diagnostics

## Description

The `Diagnostic` interface class is the means by which the `matlab.unittest` framework and its clients package diagnostic information. All diagnostics are derived from `Diagnostic`, whether they are user-supplied test diagnostics for an individual comparison or diagnostics associated with the `Constraint` used in the comparison.

Classes which derive from `Diagnostic` encode the diagnostic actions to be performed. They produce a diagnostic result that is displayed appropriately by the test running framework. In exchange for meeting this requirement, any `Diagnostic` implementation can be used directly with `matlab.unittest` qualifications. These qualifications execute the diagnostic action and store the result to be utilized by the test running framework.

As a convenience, the framework creates appropriate diagnostic instances for strings and function handles when they are user supplied test diagnostics. To retain good performance, these values are only converted into `Diagnostic` instances when a qualification failure occurs or when the test running framework is explicitly observing passing qualifications. The default test runner does not explicitly observe passing qualifications.

## Properties

### `DiagnosticResult`

The `DiagnosticResult` property provides the means by which the actual diagnostic information is communicated to consumers of diagnostics, such as testing frameworks. The property is a string that is defined during evaluation of the `diagnose` method.

## Methods

|                       |                                               |
|-----------------------|-----------------------------------------------|
| <code>diagnose</code> | Execute diagnostic action                     |
| <code>join</code>     | Join multiple diagnostics into a single array |

# matlab.unittest.diagnostics.Diagnostic

---

## Copy Semantics

Handle. To learn how handle classes affect copy operations, see Copying Objects in the MATLAB documentation.

## Examples

### Use Diagnostic Result

```
import matlab.unittest.constraints.IsEqualTo;

% Create a TestCase for interactive use
testCase = matlab.unittest.TestCase;

% Create StringDiagnostic upon failure
testCase.verifyThat(1, IsEqualTo(2), 'User supplied Diagnostic');

% Create FunctionHandleDiagnostic upon failure
testCase.verifyThat(1, IsEqualTo(2), @() system('ps'));

% Usage of user defined Diagnostic upon failure (see definition below)
testCase.verifyThat(1, IsEqualTo(2), ProcessStatusDiagnostic...
 ('Could not close my third party application!'));

%%
% Diagnostic definition
%%
classdef ProcessStatusDiagnostic < matlab.unittest.diagnostics.Diagnostic
 % ProcessStatusDiagnostic - an example diagnostic
 %
 % Simple example to demonstrate how to create a custom
 % diagnostic.

 properties

 % HeaderText - user-supplied header to display
 HeaderText = '(No header supplied)';
 end

 methods
 function diag = ProcessStatusDiagnostic(header)
```

```
% Constructor - construct a ProcessStatusDiagnostic
%
% The ProcessStatusDiagnostic constructor takes an
% optional header to be displayed along with process
% information.
if (nargin > 0)
 diag.HeaderText = header;
end
end

function diagnose(diag)

 [status processInfo] = system('ps');
 if (status ~= 0)
 processInfo = sprintf(...
 ['!!! Could not obtain status diagnostic informati
 ' [exit status code: %d]\n%s'], status, processInfo);
 end
 diag.DiagnosticResult = sprintf('%s\n%s', diag.HeaderText,
 processInfo);
 end
end

end %classdef
```

## See Also

[StringDiagnostic](#) | [FunctionHandleDiagnostic](#)  
| [matlab.unittest.diagnostics](#) |  
[matlab.unittest.plugins.DiagnosticsValidationPlugin](#) |  
[matlab.unittest.constraints.Constraint](#)

## Concepts

- “Types of Qualifications”

# matlab.unittest.diagnostics.Diagnostic.diagnose

---

**Purpose** Execute diagnostic action

**Syntax** `diagnose(diag)`

**Description** `diagnose(diag)` executes diagnostic action for the `matlab.unittest.diagnostics.Diagnostic` instance, `diag`. The `diagnose` method is the means by which individual `Diagnostic` implementations can perform their respective diagnostic evaluations. Each concrete implementation is responsible for populating the `DiagnosticResult` property of the `Diagnostic` object. Typically, text printed to the Command Window during diagnostic evaluation is not considered part of the diagnostic result and is ignored by the testing framework.

**See Also** `Diagnostic`

|                         |                                                                                                                                                                                                                                                                                                                                                                                                                                                                                                                                                                                                                                                             |
|-------------------------|-------------------------------------------------------------------------------------------------------------------------------------------------------------------------------------------------------------------------------------------------------------------------------------------------------------------------------------------------------------------------------------------------------------------------------------------------------------------------------------------------------------------------------------------------------------------------------------------------------------------------------------------------------------|
| <b>Purpose</b>          | Join multiple diagnostics into a single array                                                                                                                                                                                                                                                                                                                                                                                                                                                                                                                                                                                                               |
| <b>Syntax</b>           | <code>diagArray = join(diag1,...,diagN)</code>                                                                                                                                                                                                                                                                                                                                                                                                                                                                                                                                                                                                              |
| <b>Description</b>      | <code>diagArray = join(diag1,...,diagN)</code> joins multiple diagnostics, specified by <code>diag1</code> through <code>diagN</code> , into a single array, <code>diagArray</code> .                                                                                                                                                                                                                                                                                                                                                                                                                                                                       |
| <b>Input Arguments</b>  | <p><b>diag</b></p> <p>Diagnostic content, specified as an instance of a <code>Diagnostic</code> object, a string, a function handle, or an arbitrary type.</p>                                                                                                                                                                                                                                                                                                                                                                                                                                                                                              |
| <b>Output Arguments</b> | <p><b>diagArray</b></p> <p>Array of joined diagnostic content.</p> <ul style="list-style-type: none"><li>• If <code>diagN</code> is an object that derives from <code>Diagnostic</code>, it is included in the array unmodified.</li><li>• If <code>diagN</code> is a char, it is formed into a <code>StringDiagnostic</code> and included in the array.</li><li>• If <code>diagN</code> is a <code>function_handle</code>, it is formed into a <code>FunctionHandleDiagnostic</code> and included in the array.</li><li>• If <code>diagN</code> is any other type, it is formed into a <code>DisplayDiagnostic</code> and included in the array.</li></ul> |
| <b>Alternatives</b>     | <p>You can use array concatenation <code>join</code> diagnostics into an array if at least one of the values is a diagnostic. The <code>join</code> method prevents the need to have any <code>Diagnostics</code> in the array. Considering the following example.</p> <pre>arbitraryValue = 5; testCase.verifyThat(false, IsTrue, ...     ['should have been true', ...     @() system('ps'), ...     arbitraryValue, ...     MyCustomDiagnostic]);</pre>                                                                                                                                                                                                  |

# matlab.unittest.diagnostics.Diagnostic.join

---

Since MyCustomDiagnostic is a Diagnostic, the other values are correctly converted to diagnostics as well.

## Examples

### Join Diagnostic Content

```
% The following example creates a diagnostic array of length 4,
% demonstrating standard Diagnostic conversions. Note:
% MyCustomDiagnostic is for example purposes and is not executable
% code.
```

```
import matlab.unittest.diagnostics.Diagnostic;
import matlab.unittest.constraints.IsTrue;
```

```
arbitraryValue = 5;
testCase.verifyThat(false, IsTrue, ...
 Diagnostic.join(...
 'should have been true', ...
 @() system('ps'), ...
 arbitraryValue, ...
 MyCustomDiagnostic))
```

**See Also** [matlab.mixin.Heterogeneous](#)



**Superclasses** Diagnostic

**Purpose** Diagnostic using a value's displayed output

**Description** The DisplayDiagnostic class provides a diagnostic result that uses a value's displayed output. This output is the same text displayed using the `display` function. When the diagnostic information is accessible through a variable in the current workspace, the DisplayDiagnostic class is a means to provide quick diagnostic information.

**Construction** `DisplayDiagnostic(diagValue)` creates a new DisplayDiagnostic instance.

## Input Arguments

### diagValue

The value that the Diagnostic uses to generate diagnostic information.

The resulting diagnostic information is equivalent to displaying this value at the MATLAB command prompt. The result is packaged for consumption by the testing framework, which may or may not display the information at the command prompt.

**Properties** **Value**

The value that the Diagnostic uses to generate diagnostic information, specified in the `diagValue` input argument. This property is read-only.

## Inherited Properties

### DiagnosticResult

The `DiagnosticResult` property provides the means by which the actual diagnostic information is communicated to consumers of diagnostics, such as testing frameworks. The property is a string that is defined during evaluation of the `diagnose` method.

# matlab.unittest.diagnostics.DisplayDiagnostic

---

## Methods

## Inherited Methods

|          |                                               |
|----------|-----------------------------------------------|
| diagnose | Execute diagnostic action                     |
| join     | Join multiple diagnostics into a single array |

## Copy Semantics

Handle. To learn how handle classes affect copy operations, see Copying Objects in the MATLAB documentation.

## Examples

### Create DisplayDiagnostic Object

Create a test case for interactive testing.

```
import matlab.unittest.TestCase;
import matlab.unittest.constraints.IsEqualTo;
import matlab.unittest.diagnostics.DisplayDiagnostic;
```

```
testCase = TestCase.forInteractiveUse;
```

Use a `DisplayDiagnostic` to display diagnostic information upon test failure.

```
testCase.verifyThat(1, IsEqualTo(2), DisplayDiagnostic(inputParser));
```

```
Interactive verification failed.
```

```

Test Diagnostic:

```

```
inputParser with properties:
```

```
 FunctionName: ''
 CaseSensitive: 0
 KeepUnmatched: 0
 PartialMatching: 1
 StructExpand: 1
 Parameters: {1x0 cell}
```

```
Results: [1x1 struct]
Unmatched: [1x1 struct]
UsingDefaults: {1x0 cell}
```

```

Framework Diagnostic:

IsEqualTo failed.
--> NumericComparator failed.
 --> The values are not equal using "isequaln".

Actual Value:
 1
Expected Value:
 2
```

In the test diagnostic section of the output, the output from `inputParser` object is the same as MATLAB displays at the command prompt.

## See Also

[FunctionHandleDiagnostic](#) | [StringDiagnostic](#) |  
[matlab.unittest.diagnostics](#)

## Concepts

# matlab.unittest.diagnostics.FunctionHandleDiagnostic

---

**Superclasses** Diagnostic

**Purpose** Diagnostic using a function's displayed output

**Description** The FunctionHandleDiagnostic class provides a diagnostic result using a function's displayed output. This output is the same as the text displayed at the command prompt when MATLAB executes the function handle. When the diagnostic information is accessible through information displayed as output of the function handle, the FunctionHandleDiagnostic is a means to provide quick diagnostic information.

When using matlab.unittest qualifications, a function handle can be supplied directly as a test diagnostic. In this case, the testing framework automatically creates a FunctionHandleDiagnostic object.

**Construction** FunctionHandleDiagnostic(fcnHandle) creates a new FunctionHandleDiagnostic instance.

## Input Arguments

### fcnHandle

The function handle that the Diagnostic uses to generate diagnostic information.

The resulting diagnostic information is equivalent to output displayed at the MATLAB command prompt. The result is packaged for consumption by the testing framework, which may or may not display the information at the command prompt.

**Properties** Fcn

The function handle that the Diagnostic uses to generate diagnostic information, specified in the fcnHandle input argument. This property is read-only.

## Inherited Properties

### DiagnosticResult

The `DiagnosticResult` property provides the means by which the actual diagnostic information is communicated to consumers of diagnostics, such as testing frameworks. The property is a string that is defined during evaluation of the `diagnose` method.

## Methods

### Inherited Methods

|                       |                                               |
|-----------------------|-----------------------------------------------|
| <code>diagnose</code> | Execute diagnostic action                     |
| <code>join</code>     | Join multiple diagnostics into a single array |

## Copy Semantics

Handle. To learn how handle classes affect copy operations, see [Copying Objects in the MATLAB documentation](#).

## Examples

### Create FunctionHandleDiagnostic Object

Create a diagnostic result that displays the output of the `dir` function when a test fails.

Create a folder in your current working folder.

```
mkdir('subfolderInCurrentFolder');
```

Create a test case for interactive testing.

```
import matlab.unittest.TestCase;
import matlab.unittest.constraints.IsEqualTo;
import matlab.unittest.diagnostics.FunctionHandleDiagnostic;

testCase = TestCase.forInteractiveUse;
```

Use a `FunctionHandleDiagnostic` to display diagnostic information upon test failure.

# matlab.unittest.diagnostics.FunctionHandleDiagnostic

---

```
testCase.verifyThat(1, IsEqualTo(2), FunctionHandleDiagnostic(@dir));
```

```
Interactive verification failed.
```

```

Test Diagnostic:
```

```

```

```
. .. subfolderInCurrentFolder
```

```

Framework Diagnostic:
```

```

```

```
IsEqualTo failed.
```

```
--> NumericComparator failed.
```

```
 --> The values are not equal using "isequaln".
```

```
Actual Value:
```

```
 1
```

```
Expected Value:
```

```
 2
```

Upon test failure, the diagnostic displays the contents of the current working folder. In this example output, the folder only contains the subfolder `subfolderInCurrentFolder`.

Alternatively, the test framework can create a `FunctionHandleDiagnostic` object for you from a function handle input to the `verifyThat` qualification.

```
testCase.verifyThat(1, IsEqualTo(2), @dir);
```

```
Interactive verification failed.
```

```

Test Diagnostic:
```

# matlab.unittest.diagnostics.FunctionHandleDiagnostic

---

```

.
.. subfolderInCurrent
```

```

Framework Diagnostic:

IsEqualTo failed.
--> NumericComparator failed.
 --> The values are not equal using "isequaln".

Actual Value:
 1
Expected Value:
 2
```

The testing framework only creates the `FunctionHandleDiagnostic` object as needed, typically only in the event of a test failure.

## See Also

`StringDiagnostic` | `matlab.unittest.diagnostics` |  
`matlab.unittest.plugins.DiagnosticsValidationPlugin`

## Concepts

# matlab.unittest.diagnostics.StringDiagnostic

---

**Superclasses** Diagnostic

**Purpose** Diagnostic using string

**Description** The StringDiagnostic class provides a diagnostic result that uses a string. When the diagnostic information is known at the time of construction, the StringDiagnostic is a means to provide quick diagnostic information.

When using matlab.unittest qualifications, a string can be supplied directly as a test diagnostic. In this case, the testing framework automatically creates a StringDiagnostic object.

**Construction** StringDiagnostic(diagString) creates a new StringDiagnostic instance.

## Input Arguments

### diagString

The string that the Diagnostic uses to generate diagnostic information.

**Properties** **Inherited Properties**

### DiagnosticResult

The DiagnosticResult property provides the means by which the actual diagnostic information is communicated to consumers of diagnostics, such as testing frameworks. The property is a string that is defined during evaluation of the diagnose method.

**Methods** **Inherited Methods**

diagnose

Execute diagnostic action

join

Join multiple diagnostics into a single array



## Copy Semantics

Handle. To learn how handle classes affect copy operations, see Copying Objects in the MATLAB documentation.

## Examples

### Create StringDiagnostic Object

Create a test case for interactive testing.

```
import matlab.unittest.TestCase;
import matlab.unittest.constraints.IsEqualTo;
import matlab.unittest.diagnostics.StringDiagnostic;
```

```
testCase = TestCase.forInteractiveUse;
```

Use a `StringDiagnostic` to display diagnostic information upon test failure.

```
testCase.verifyThat(1, IsEqualTo(2), ...
 StringDiagnostic('actual was supposed to be equal to expected'))
```

```
Interactive verification failed.
```

```

Test Diagnostic:
```

```

actual was supposed to be equal to expected
```

```

Framework Diagnostic:
```

```

IsEqualTo failed.
--> NumericComparator failed.
 --> The values are not equal using "isequaln".
```

```
Actual Value:
```

```
 1
```

```
Expected Value:
```

```
 2
```

# matlab.unittest.diagnostics.StringDiagnostic

---

Alternatively, the test framework can create a `StringDiagnostic` object for you from a string input to the `verifyThat` qualification.

```
testCase.verifyThat(1, IsEqualTo(2), ...
 'actual was supposed to be equal to expected');
```

```
Interactive verification failed.
```

```

Test Diagnostic:

```

```
actual was supposed to be equal to expected
```

```

Framework Diagnostic:

```

```
IsEqualTo failed.
```

```
--> NumericComparator failed.
```

```
--> The values are not equal using "isequaln".
```

```
Actual Value:
```

```
 1
```

```
Expected Value:
```

```
 2
```

The testing framework only creates the `StringDiagnostic` object as needed, typically only in the event of a test failure.

## See Also

`FunctionHandleDiagnostic` | `matlab.unittest.diagnostics`

## Concepts

**Purpose** Create and display empty dialog box

**Syntax** `h = dialog('PropertyName',PropertyValue,...)`

**Description** `h = dialog('PropertyName',PropertyValue,...)` returns a handle to a dialog box. The dialog box is a figure graphics object with properties recommended for dialog boxes. You can specify any valid figure property value except `DockControls`, which is always `off`.

The following table contains the properties that `dialog` sets and their default values.

| Property            | Value                                        |
|---------------------|----------------------------------------------|
| 'ButtonDownFcn'     | 'if isempty(allchild(gcf)), close(gcf), end' |
| 'Colormap'          | []                                           |
| 'Color'             | DefaultUicontrolBackgroundColor              |
| 'DockControls'      | 'off'                                        |
| 'HandleVisibility'  | 'callback'                                   |
| 'IntegerHandle'     | 'off'                                        |
| 'InvertHardcopy'    | 'off'                                        |
| 'MenuBar'           | 'none'                                       |
| 'NumberTitle'       | 'off'                                        |
| 'PaperPositionMode' | 'auto'                                       |
| 'Resize'            | 'off'                                        |
| 'Visible'           | 'on'                                         |
| 'WindowStyle'       | 'modal'                                      |

---

**Note** By default, the dialog box is modal. A modal dialog box prevents users from interacting with other windows before responding to the modal dialog box. For more information, see `WindowStyle` in the MATLAB Figure Properties.

---

The default `ButtonDownFcn` value causes the dialog box to terminate itself when a user clicks it, if the dialog box contains no child objects. Replace the default `ButtonDownFcn` value with another value or an empty value if you do not want this behavior. You can do this only from a script or function if the dialog box is modal (the default `WindowStyle`).

Any property you can specify for the figure function is valid for the `ButtonDownFcn` function.

## Examples

### Default modal dialog box

```
out = dialog;
```

### Nonmodal dialog box

Create a nonmodal dialog box with a name on its title bar.

```
out = dialog('WindowStyle', 'normal', 'Name', 'My Dialog');
```

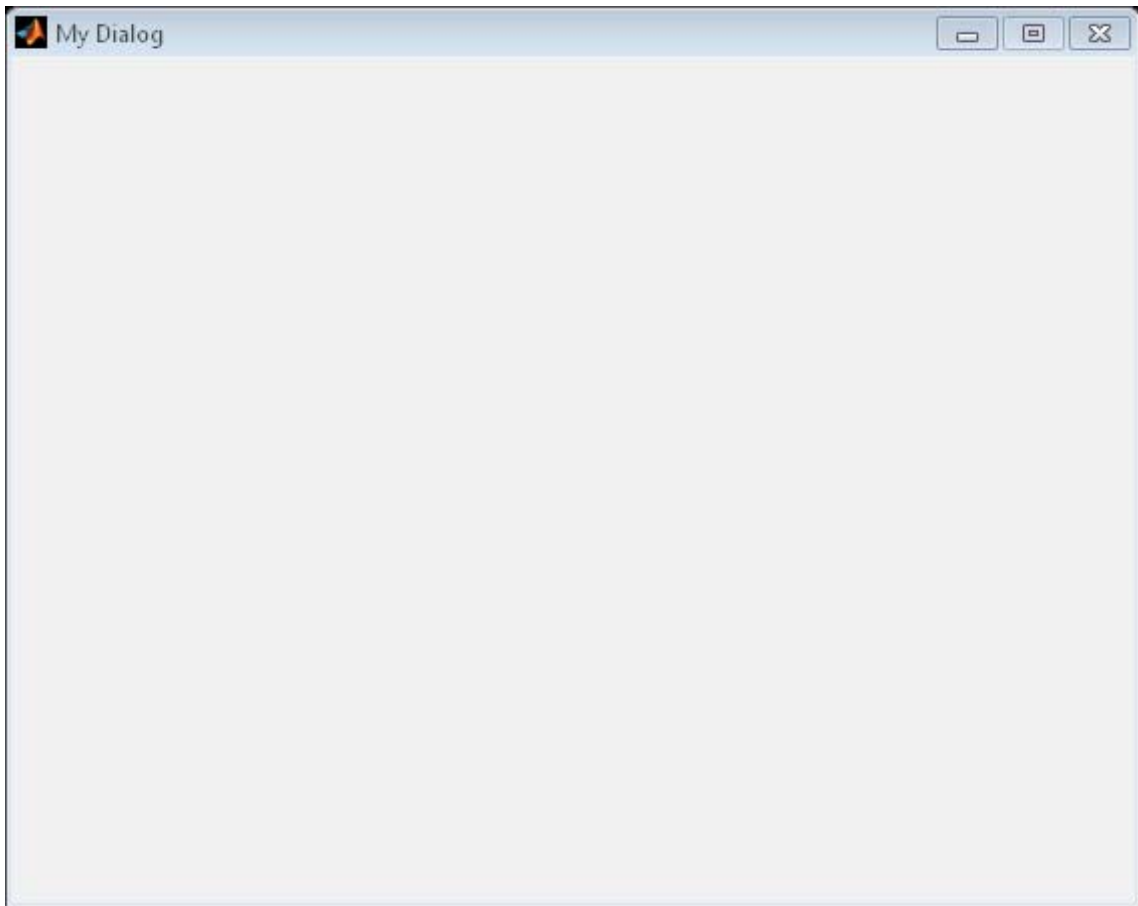

**See Also**

`errordlg` | `helpdlg` | `inputdlg` | `listdlg` | `msgbox` | `questdlg` | `warndlg` | `figure` | `uiwait` | `uiresume`

# diary

---

**Purpose** Save Command Window text to file

**Syntax**

```
diary
diary('filename')
diary off
diary on
diary filename
```

**Description** The `diary` function creates a log of keyboard input and the resulting text output, with some exceptions (see “Tips” on page 1-1756 for details). The output of `diary` is an ASCII file, suitable for searching in, printing, inclusion in most reports and other documents. If you do not specify `filename`, the MATLAB software creates a file named `diary` in the current folder.

`diary` toggles diary mode on and off. To see the status of `diary`, type `get(0, 'Diary')`. MATLAB returns either `on` or `off` indicating the diary status.

`diary('filename')` writes a copy of all subsequent keyboard input and the resulting output (except it does not include graphics) to the named file, where `filename` is the full pathname or `filename` is in the current MATLAB folder. If the file already exists, output is appended to the end of the file. You cannot use a `filename` called `off` or `on`. To see the name of the diary file, use `get(0, 'DiaryFile')`.

`diary off` suspends the diary.

`diary on` resumes diary mode using the current filename, or the default filename `diary` if none has yet been specified.

`diary filename` is the unquoted form of the syntax.

**Tips** Because the output of `diary` is plain text, the file does not exactly mirror input and output from the Command Window:

- Output does not include graphics (figure windows).
- Syntax highlighting and font preferences are not preserved.

- Hidden components of Command Window output such as hyperlink information generated with `matlab:` are shown in plain text. For example, if you enter the following statement

```
str = sprintf('%s%s', ...
 '', ...
 'Generate magic square');
disp(str)
```

MATLAB displays

[Generate magic square](#)

However, the diary file, when viewed in a text editor, shows

```
str = sprintf('%s%s', ...
 '', ...
 'Generate magic square');
disp(str)
Generate magic square
```

If you view the output of `diary` in the Command Window, the Command Window interprets the `<a href ...>` statement and displays it as a hyperlink.

- Viewing the output of `diary` in a console window might produce different results compared to viewing `diary` output in the desktop Command Window. One example is using the `\r` option for the `fprintf` function; using the `\n` option might alleviate that problem.

## See Also

`evalc`

## How To

- “Command History”

# diff

---

## Purpose

Differences and Approximate Derivatives

## Syntax

```
Y = diff(X)
Y = diff(X,n)
Y = diff(X,n,dim)
```

## Description

$Y = \text{diff}(X)$  calculates differences between adjacent elements of  $X$  along the first array dimension whose size does not equal 1:

- If  $X$  is a vector of length  $m$ , then  $Y = \text{diff}(X)$  returns a vector of length  $m-1$ . The elements of  $Y$  are the differences between adjacent elements of  $X$ .

$$Y = [X(2)-X(1) \quad X(3)-X(2) \quad \dots \quad X(m)-X(m-1)]$$

- If  $X$  is a nonempty, nonvector  $p$ -by- $m$  matrix, then  $Y = \text{diff}(X)$  returns a matrix of size  $(p-1)$ -by- $m$ , whose elements are the differences between the rows of  $X$ .

$$Y = [X(2,:) - X(1,:); \quad X(3,:) - X(2,:); \quad \dots \quad X(p,:) - X(p-1,:)]$$

- If  $X$  is a 0-by-0 empty matrix, then  $Y = \text{diff}(X)$  returns a 0-by-0 empty matrix.

$Y = \text{diff}(X,n)$  calculates the  $n$ th difference by applying the  $\text{diff}(X)$  operator recursively  $n$  times. In practice, this means  $\text{diff}(X,2)$  is the same as  $\text{diff}(\text{diff}(X))$ .

$Y = \text{diff}(X,n,\text{dim})$  is the  $n$ th difference calculated along the dimension specified by  $\text{dim}$ . The  $\text{dim}$  input is a positive integer scalar.

## Input Arguments

### **X** - Input array

vector | matrix | multidimensional array

Input array, specified as a vector, matrix, or multidimensional array.



**Data Types**

single | double | int8 | int16 | int32 | int64 | uint8 |  
uint16 | uint32 | uint64 | logical

**Complex Number Support:** Yes

**n - Difference order**

positive integer scalar | []

Difference order, specified as a positive integer scalar or []. The default value of n is 1.

It is possible to specify n sufficiently large so that dim reduces to a single ( $\text{size}(X, \text{dim}) = 1$ ) dimension. When this happens, diff continues calculating along the next array dimension whose size does not equal 1. This process continues until a 0-by-0 empty matrix is returned.

**Data Types**

single | double | int8 | int16 | int32 | int64 | uint8 |  
uint16 | uint32 | uint64

**dim - Dimension to operate along**

positive integer scalar

Dimension to operate along, specified as a positive integer scalar. If no value is specified, the default is the first array dimension whose size does not equal 1.

Consider a two-dimensional p-by-m input array, A:

- `diff(A,1,1)` works on successive elements in the columns of A and returns a (p-1)-by-m difference matrix.
- `diff(A,1,2)` works on successive elements in the rows of A and returns a p-by-(m-1) difference matrix.

# diff

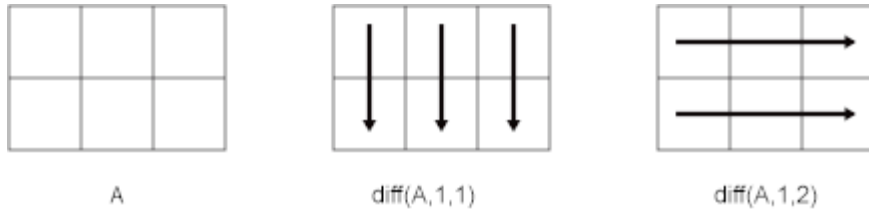

## Data Types

double | single | int8 | int16 | int32 | int64 | uint8 |  
uint16 | uint32 | uint64

## Output Arguments

### Y - Difference array

scalar | vector | matrix | multidimensional array

Difference array, returned as a scalar, vector, matrix, or multidimensional array. If X is a nonempty array, then the dimension of X acted on by diff is reduced in size by n in the output.

## Examples

### Differences Between Vector Elements

Create a vector, then compute the differences between the elements.

```
X = [1 1 2 3 5 8 13 21];
Y = diff(X)
```

```
Y =
```

```
0 1 1 2 3 5 8
```

Note that Y has one fewer element than X.

### Differences Between Matrix Rows

Create a 3-by-3 matrix, then compute the first difference between the rows.

```
X = [1 1 1; 5 5 5; 25 25 25];
Y = diff(X)
```

Y =

```

 4 4 4
 20 20 20

```

The output Y is a 2-by-3 difference matrix.

### Multiple Differences

Create a vector and compute the second-order difference between the elements.

```

X = [0 5 15 30 50 75 105];
Y = diff(X,2)

```

Y =

```

 5 5 5 5 5

```

### Differences Between Matrix Columns

Create a 3-by-3 matrix, then compute the first-order difference between the columns.

```

X = [1 3 5;7 11 13;17 19 23];
Y = diff(X,1,2)

```

Y =

```

 2 2
 4 2
 2 4

```

The output Y is a 3-by-2 difference matrix.

### Approximate Derivatives with diff

Use the diff function to approximate partial derivatives with the syntax  $Y = \text{diff}(f)/h$ , where  $f$  is a vector of function values evaluated over some domain,  $X$ , and  $h$  is an appropriate step size.

# diff

---

For example, the first derivative of  $\sin(x)$  with respect to  $x$  is  $\cos(x)$ , and the second derivative with respect to  $x$  is  $-\sin(x)$ . You can use `diff` to approximate these derivatives.

```
h = 0.001; %step size
X = -pi:h:pi; %domain
f = sin(X); %range
Y = diff(f)/h; %first derivative
Z = diff(Y)/h; %second derivative
plot(X(:,1:length(Y)),Y,'r',X,f,'b', X(:,1:length(Z)),Z,'k')
```

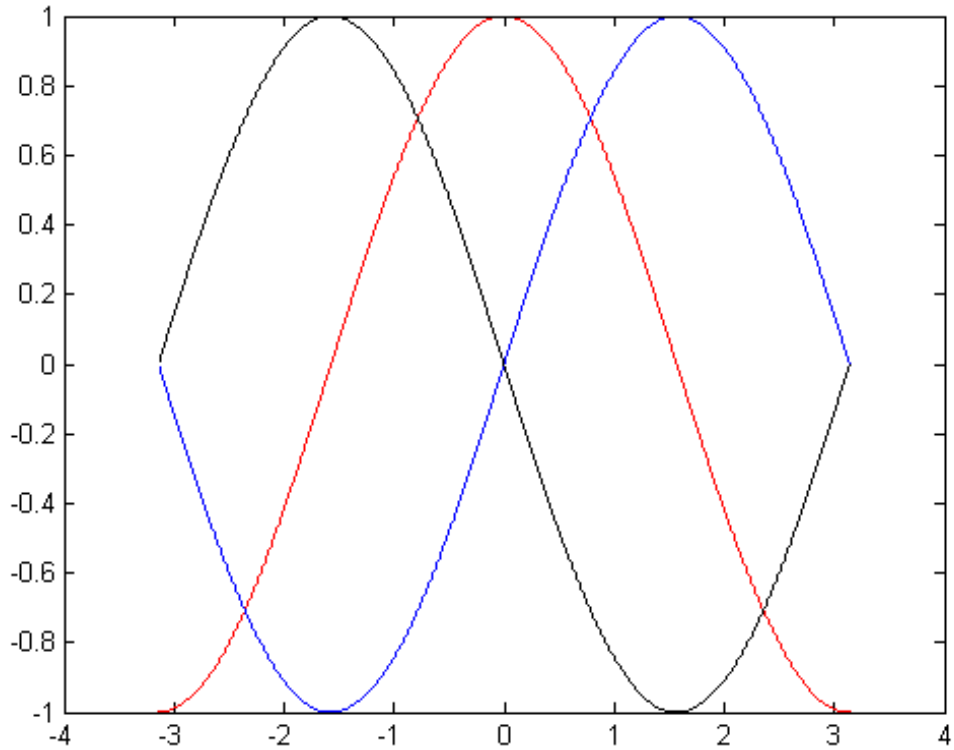

In this plot the blue line corresponds to the original function,  $\sin$ . The red line corresponds to the calculated first derivative,  $\cos$ , and the black line corresponds to the calculated second derivative,  $-\sin$ .

### See Also

[gradient](#) | [prod](#) | [cumsum](#) | [sum](#)

# diffuse

---

**Purpose** Calculate diffuse reflectance

**Syntax** `R = diffuse(Nx,Ny,Nz,S)`

**Description** `R = diffuse(Nx,Ny,Nz,S)` returns the reflectance of a surface with normal vector components `[Nx,Ny,Nz]`. `S` specifies the direction to the light source. You can specify these directions as three vectors `[x,y,z]` or two vectors `[Theta Phi]` (in spherical coordinates).

Lambert's Law:  $R = \cos(\text{PSI})$  where `PSI` is the angle between the surface normal and light source.

**See Also** `specular` | `surfnorm` | `surf1`

**How To**

- “Lighting Overview”

**Purpose**

List folder contents

**Syntax**

```
dir
dir name
listing = dir(name)
```

**Description**

`dir` lists the files and folders in the MATLAB current folder. Results appear in the order returned by the operating system.

`dir name` lists the files and folders that match the string `name`. When `name` is a folder, `dir` lists the contents of the folder. Specify `name` using absolute or relative path names. You can use wildcards (\*).

`listing = dir(name)` returns attributes about `name`.

**Tips**

- To obtain a list of available drives on Microsoft Windows platforms:

Use the DOS `net use` command in the Command Window:

```
dos('net use')
```

Or

```
[s,r] = dos('net use')
```

MATLAB returns the results to the character array `r`.

- Short DOS file name support

The MATLAB `dir` function is consistent with the Microsoft Windows operating system `dir` command in that both support short file names generated by DOS.

- Structure Results for Nonexistent Files

When you run `dir` with an output argument and the results include a nonexistent file or a file that `dir` cannot query for some other reason, then `dir` returns the following default values:

```
date: ''
bytes: []
```

# dir

---

```
isdir: 0
datenum: []
```

The most common occurrence is on UNIX<sup>1</sup> platforms when `dir` queries a file that is a symbolic link, which points to a nonexistent target. A nonexistent target is a target that was moved, removed, or renamed. For example, if `my_file` in `my_dir` is a symbolic link to another file that was deleted, then running

```
r = dir('my_dir')
```

includes this result for `my_file`:

```
r(n) =
 name: 'my_file'
 date: ''
 bytes: []
 isdir: 0
 datenum: []
```

where  $n$  is the index for `my_file`, found by searching `r` by the `name` field.

## Input Arguments

### **name**

A string value specifying a file or folder name.

## Output Arguments

### **listing**

| Field Name | Description                 | Class      |
|------------|-----------------------------|------------|
| name       | File or folder name         | char array |
| date       | Modification date timestamp | char array |

1. UNIX is a registered trademark of The Open Group in the United States and other countries.



| Field Name | Description                                                             | Class   |
|------------|-------------------------------------------------------------------------|---------|
| bytes      | Size of the file in bytes                                               | double  |
| isdir      | 1 if name is a folder; 0 if not                                         | logical |
| datenum    | Modification date as serial date number. The value is locale-dependent. | double  |

## Examples

### View the Contents of a Folder

View the contents of the matlab/audioplayer folder:

```
dir(fullfile(matlabroot, 'toolbox/matlab/audioplayer'))
```

### Find Information in the Return Structure

Return the folder listing, restricted to files with a .m extension, to the variable av\_files:

```
av_files = dir(fullfile(matlabroot, ...
 'toolbox/matlab/audioplayer/*.m'))
```

MATLAB returns the information in a structure array:

```
av_files =
25x1 struct array with fields:
 name
 date
 bytes
 isdir
 datenum
```

Index into the structure to access a particular item:

```
av_files(3).name
ans =
 audioplayerreg.m
```

## - Use the Wildcard Character to Find Multiple Files

View the MAT-files in the current folder that include the term `my_data` by using the wildcard character:

```
dir *my_data*.mat
```

MATLAB returns all file names that match this specification. For instance, it returns the following if they are in the current folder:

```
old_my_data.mat my_data_final.mat my_data_test.mat
```

## - Exclude Certain Files from the Output

Return the list of files in the current folder, excluding those files that `dir` cannot query:

```
y = dir;
y = y(find(~cellfun(@isempty,{y(:).date})));
```

## - Find the Date a File Was Modified

To get the serial date number for the date and time a file was last modified, use the `datenum` field of the structure returned by the `dir` command:

```
DirInfo = dir('startup.m');
filedate = DirInfo.datenum
```

Using the `datenum` function to convert the string returned in the `date` field of the structure is not recommended as this can behave differently in different locales.

```
filedate = datenum(DirInfo.date)
```

## Alternatives

Use the Current Folder browser to view the list of files in a folder.

## See Also

`cd` | `fileattrib` | `isdir` | `ls` | `mkdir` | `rmdir` | `what`

## How To

- “Specify File Names”

**Purpose** View contents of folder on FTP server

**Syntax**

```
dir(ftpobj)
dir(ftpobj, folder)
details = dir(ftpobj, folder)
```

**Description**

`dir(ftpobj)` lists the files in current folder on the FTP server associated with `ftpobj`.

`dir(ftpobj, folder)` lists the files in the specified folder.

`details = dir(ftpobj, folder)` returns the results in a structure array that contains the name, modification date, and size of each file.

**Input Arguments**

**ftpobj**  
FTP object created by `ftp`.

**folder**  
String enclosed in single quotation marks that specifies the target folder. To specify the folder above the current one, use `'..'`.

**Output Arguments**

**details**  
`m`-by-1 structure array, where `m` is the number of files in the folder. Each element of the structure array contains the following fields:

| Field Name | Description                              | Data Type |
|------------|------------------------------------------|-----------|
| name       | File name                                | char      |
| date       | Modification date<br>timestamp           | char      |
| bytes      | Number of bytes<br>allocated to the file | double    |

# FTP.dir

---

| Field Name | Description                                 | Data Type |
|------------|---------------------------------------------|-----------|
| isdir      | If a folder, isdir = 1, otherwise isdir = 0 | logical   |
| datenum    | Modification date as serial date number     | char      |

## Examples

Connect to the MathWorks FTP server and view the contents:

```
mw=ftp('ftp.mathworks.com');
dir(mw)
```

This code returns:

```
README incoming matlab outgoing pub pubs
```

---

Continuing the previous example, save the folder contents to the structure `m`, close the connection, and view details about the `pub` subfolder:

```
m=dir(mw);
close(mw);
```

```
m(5)
```

This code returns:

```
ans =
 name: 'pub'
 date: '13-Aug-2008 00:00:00'
 bytes: 512
 isdir: 1
 datenum: 733633
```

## See Also

`cd` | `ftp` | `mkdir` | `rmdir`

**Purpose** Display text or array

**Syntax** disp(X)

**Description** disp(X) displays the contents of X without printing the variable name. disp does not display empty variables.

**Input Arguments** **X - Variable to display**  
variable name  
Variable to display, specified by the variable name.

### Examples **Display Matrix with Column Labels**

Display a matrix and label the columns as Corn, Oats, and Hay.

```
X = gallery('uniformdata',[5 3],0);
disp(' Corn Oats Hay')
disp(X)
```

| Corn   | Oats   | Hay    |
|--------|--------|--------|
| 0.9501 | 0.7621 | 0.6154 |
| 0.2311 | 0.4565 | 0.7919 |
| 0.6068 | 0.0185 | 0.9218 |
| 0.4860 | 0.8214 | 0.7382 |
| 0.8913 | 0.4447 | 0.1763 |

### Display Hyperlink in Command Window

Include the full hypertext string on a single line as input to disp.

```
X = 'MathWorks Web Site';
disp(X)
```

```
MathWorks Web Site
```

The `disp` function generates a hyperlink in the Command Window. Click the link to display the MathWorks home page in a MATLAB Web browser.

## Display Multiple Items on Same Line

Concatenate strings together using the `[]` operator. Convert any numeric values to characters using the `num2str` function.

```
name = 'Alice'; age = 12;
X = [name, ' will be ', num2str(age), ' this year.'];
```

Display the string.

```
disp(X)
```

```
Alice will be 12 this year.
```

You also can use `sprintf` to create a string. Terminate the `sprintf` command with a semicolon to prevent "X = " from being displayed. Then, use `disp` to display the string.

```
name = 'Alice'; age = 12;
X = sprintf('%s will be %d this year.', name, age);
disp(X)
```

```
Alice will be 12 this year.
```

Alternatively, use `fprintf` to create and display the string. Unlike the `sprintf` function, `fprintf` does not display the "X = " text. However, you need to end the string with the newline (`\n`) metacharacter to terminate its display properly.

```
name = 'Alice'; age = 12;
X = fprintf('%s will be %d this year.\n', name, age);
```

```
Alice will be 12 this year.
```

**Tips**

- The `disp` function accepts only one input. To display more than one array or string, you can use concatenation or the `sprintf` or `fprintf` functions as shown in the Example, “Display Multiple Items on Same Line” on page 1-1772.

**See Also**

`format` | `int2str` | `num2str` | `rats` | `sprintf` | `fprintf` | `colon` (`:`)

# disp (MException)

---

**Purpose** Display MException object

**Syntax** disp(exception)  
disp(exception.property)

**Description** disp(exception) displays all properties (fields) of MException object exception.

disp(exception.property) displays the specified property of MException object exception.

**Examples** Using the surf command without input arguments throws an exception. Use disp to display the identifier, message, stack, and cause properties of the MException object:

```
try
 surf
catch exception
 disp(exception)
end
```

MException object with properties:

```
 identifier: 'MATLAB:narginchk:notEnoughInputs'
 message: 'Not enough input arguments.'
 cause: {}
 stack: [1x1 struct]
```

Display only the stack property:

```
disp(exception.stack)
 file: 'C:\Program Files\MATLAB\toolbox\matlab\graph3d\surf.m'
graph3d\surf.m'
 name: 'surf'
 line: 54
```



### See Also

eq(MException) | last(MException) | addCause(MException)  
| throwAsCaller(MException) | rethrow(MException) |  
throw(MException) | getReport(MException) | ne(MException) |  
isequal(MException) | MException | assert | error | try, catch

# disp (serial)

---

**Purpose** Serial port object summary information

**Syntax** obj  
disp(obj)

**Description** obj or disp(obj) displays summary information for obj, a serial port object or an array of serial port objects.

**Tips** In addition to the syntax shown above, you can display summary information for obj by excluding the semicolon when:

- Creating a serial port object
- Configuring property values using the dot notation

Use the display summary to quickly view the communication settings, communication state information, and information associated with read and write operations.

**Examples** The following commands display summary information for the serial port object s. on a Windows platform

```
s = serial('COM1')
s.BaudRate = 300
s
```

**Purpose** Display text and numeric expressions

**Syntax** `display(X)`

**Description** `display(X)` prints the value of `X`. MATLAB implicitly calls `display` after any variable or expression that is not terminated by a semicolon. To customize the display of objects, overload the `disp` function instead of the `display` function. `display` calls `disp`.

**Examples** **Display a Matrix**

```
X = magic(3);
display(X)
```

```
X =
```

```
 8 1 6
 3 5 7
 4 9 2
```

**Input Arguments** **X - Input value**  
`variable` | `expression`

Input value, specified as a variable or expression.

**See Also** `disp` | `ans` | `sprintf`

**Concepts**

- “Implement `disp` or `disp` and `display`”
- “Overloading Functions for Your Class”
- “Relationship Between `disp` and `display`”

# dither

---

|                      |                                                                                                                                                                                                                                                                                                                                                                                                                                                                                                                                                                                                                                                                                                                                                                                                                                                                                                                                                                                                 |
|----------------------|-------------------------------------------------------------------------------------------------------------------------------------------------------------------------------------------------------------------------------------------------------------------------------------------------------------------------------------------------------------------------------------------------------------------------------------------------------------------------------------------------------------------------------------------------------------------------------------------------------------------------------------------------------------------------------------------------------------------------------------------------------------------------------------------------------------------------------------------------------------------------------------------------------------------------------------------------------------------------------------------------|
| <b>Purpose</b>       | Convert image, increasing apparent color resolution by dithering                                                                                                                                                                                                                                                                                                                                                                                                                                                                                                                                                                                                                                                                                                                                                                                                                                                                                                                                |
| <b>Syntax</b>        | <pre>X = dither(RGB, map) X = dither(RGB, map, Qm, Qe) BW = dither(I)</pre>                                                                                                                                                                                                                                                                                                                                                                                                                                                                                                                                                                                                                                                                                                                                                                                                                                                                                                                     |
| <b>Description</b>   | <p><code>X = dither(RGB, map)</code> creates an indexed image approximation of the RGB image in the array <code>RGB</code> by dithering the colors in the colormap <code>map</code>. The colormap cannot have more than 65,536 colors.</p> <p><code>X = dither(RGB, map, Qm, Qe)</code> creates an indexed image from <code>RGB</code>, where <code>Qm</code> specifies the number of quantization bits to use along each color axis for the inverse color map, and <code>Qe</code> specifies the number of quantization bits to use for the color space error calculations. If <code>Qe &lt; Qm</code>, dithering cannot be performed, and an undithered indexed image is returned in <code>X</code>. If you omit these parameters, <code>dither</code> uses the default values <code>Qm = 5</code>, <code>Qe = 8</code>.</p> <p><code>BW = dither(I)</code> converts the grayscale image in the matrix <code>I</code> to the binary (black and white) image <code>BW</code> by dithering.</p> |
| <b>Class Support</b> | <code>RGB</code> can be <code>uint8</code> , <code>uint16</code> , <code>single</code> , or <code>double</code> . <code>I</code> can be <code>uint8</code> , <code>uint16</code> , <code>int16</code> , <code>single</code> , or <code>double</code> . All other input arguments must be <code>double</code> . <code>BW</code> is <code>logical</code> . <code>X</code> is <code>uint8</code> , if it is an indexed image with 256 or fewer colors; otherwise, it is <code>uint16</code> .                                                                                                                                                                                                                                                                                                                                                                                                                                                                                                      |
| <b>Algorithms</b>    | <code>dither</code> increases the apparent color resolution of an image by applying Floyd-Steinberg's error diffusion dither algorithm.                                                                                                                                                                                                                                                                                                                                                                                                                                                                                                                                                                                                                                                                                                                                                                                                                                                         |
| <b>References</b>    | <p>[1] Floyd, R. W., and L. Steinberg, "An Adaptive Algorithm for Spatial Gray Scale," <i>International Symposium Digest of Technical Papers</i>, Society for Information Displays, 1975, p. 36.</p> <p>[2] Lim, Jae S., <i>Two-Dimensional Signal and Image Processing</i>, Englewood Cliffs, NJ, Prentice Hall, 1990, pp. 469-476.</p>                                                                                                                                                                                                                                                                                                                                                                                                                                                                                                                                                                                                                                                        |
| <b>See Also</b>      | <code>rgb2ind</code>                                                                                                                                                                                                                                                                                                                                                                                                                                                                                                                                                                                                                                                                                                                                                                                                                                                                                                                                                                            |

**Purpose** Compute divergence of vector field

**Syntax**

```
div = divergence(X,Y,Z,U,V,W)
div = divergence(U,V,W)
div = divergence(X,Y,U,V)
div = divergence(U,V)
```

**Description** `div = divergence(X,Y,Z,U,V,W)` computes the divergence of a 3-D vector field `U, V, W`.

The arrays `X, Y, and Z`, which define the coordinates for `U, V, and W`, must be monotonic, but do not need to be uniformly spaced. `X, Y, and Z` must have the same number of elements, as if produced by `meshgrid`.

`div = divergence(U,V,W)` assumes `X, Y, and Z` are determined by the expression

```
[X Y Z] = meshgrid(1:n,1:m,1:p)
```

where `[m,n,p] = size(U)`.

`div = divergence(X,Y,U,V)` computes the divergence of a 2-D vector field `U, V`.

The arrays `X and Y`, which define the coordinates for `U and V`, must be monotonic, but do not need to be uniformly spaced. `X and Y` must have the same number of elements, as if produced by `meshgrid`.

`div = divergence(U,V)` assumes `X and Y` are determined by the expression

```
[X Y] = meshgrid(1:n,1:m)
```

where `[m,n] = size(U)`.

**Examples** This example displays the divergence of vector volume data as slice planes, using color to indicate divergence.

```
load wind
div = divergence(x,y,z,u,v,w);
```

# divergence

---

```
h = slice(x,y,z,div,[90 134],59,0);
shading interp
daspect([1 1 1])
axis tight
camlight
set([h(1),h(2)], 'ambientstrength', .6)
```

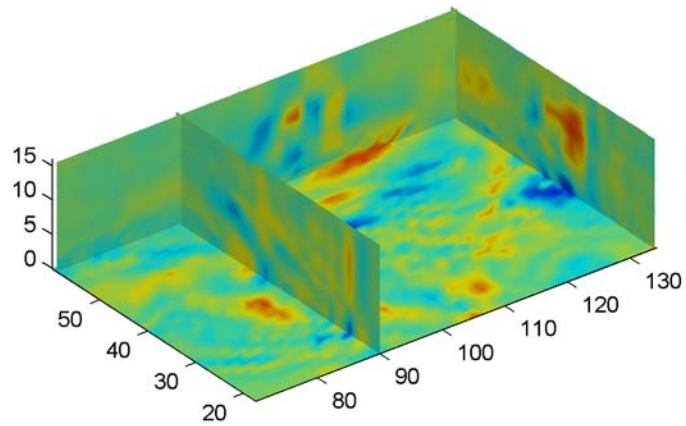

## See Also

[streamtube](#) | [curl](#) | [isosurface](#)

## How To

- “Displaying Divergence with Stream Tubes”

**Purpose**

Read ASCII-delimited file of numeric data into matrix

**Syntax**

```
M = dlmread(filename)
M = dlmread(filename, delimiter)
M = dlmread(filename, delimiter, R, C)
M = dlmread(filename, delimiter, range)
```

**Description**

`M = dlmread(filename)` reads the ASCII-delimited numeric data file `filename`, and returns the data in output matrix `M`. The `filename` input is a string enclosed in single quotes. `dlmread` infers the delimiter from the formatting of the file.

`M = dlmread(filename, delimiter)` reads data from the file, using the specified `delimiter`. Use `'\t'` to specify a tab delimiter.

`M = dlmread(filename, delimiter, R, C)` reads data whose upper left corner is at row `R` and column `C` in the file. Values `R` and `C` are zero-based, so that `R=0, C=0` specifies the first value in the file.

`M = dlmread(filename, delimiter, range)` reads the range specified by `range = [R1 C1 R2 C2]` where `(R1,C1)` is the upper left corner of the data to read and `(R2,C2)` is the lower right corner. You can also specify the range using spreadsheet notation, such as `range = 'A1..B7'`.

**Tips**

- All data in the input file must be numeric. `dlmread` does not read files that contain nonnumeric data, even if the specified rows and columns contain only numeric data.
- When `dlmread` infers the delimiter from the formatting of the file, it treats repeated white spaces as a single delimiter. By contrast, if you specify a delimiter, `dlmread` treats any repeated delimiter character as a separate delimiter.
- If you want to specify an `R, C, or range` input, but not a `delimiter`, set the `delimiter` argument to the empty string, (two consecutive single quotes with no spaces in between, `' '`). For example,

```
M = dlmread('myfile.dat', ' ', 5, 2)
```

# dlmread

---

In this case, `dlmread` treats repeated white spaces as a single delimiter.

- `dlmread` fills empty delimited fields with zero. If each line ends with a nonspace delimiter, such as a semicolon, the output matrix contains an additional last column of zeros.
- `dlmread` imports any complex number as a whole into a complex numeric field. Valid forms for a complex number are

`--<real>--<imag>i|j`                      Example: `5.7-3.1i`

`--<imag>i|j`                                Example: `-7j`

Embedded white-space in a complex number is invalid and is regarded as a field delimiter.

## Examples

### Example 1

Export a 5-by-8 test matrix `M` to a file, and read it with `dlmread`, first with no arguments other than the filename:

```
M = gallery('integerdata', 100, [5 8], 0);
dlmwrite('myfile.txt', M, 'delimiter', '\t')
```

```
dlmread('myfile.txt')
ans =
 96 77 62 41 6 21 2 42
 24 46 80 94 36 20 75 85
 61 2 93 92 82 61 45 53
 49 83 74 42 1 28 94 21
 90 45 18 90 14 20 47 68
```

Now read a portion of the matrix by specifying the row and column of the upper left corner:

```
dlmread('myfile.txt', '\t', 2, 3)
ans =
 92 82 61 45 53
```



```

42 1 28 94 21
90 14 20 47 68

```

This time, read a different part of the matrix using a range specifier:

```

dlmread('myfile.txt', '\t', 'C1..G4')
ans =
 62 41 6 21 2
 80 94 36 20 75
 93 92 82 61 45
 74 42 1 28 94

```

## Example 2

Export matrix M to a file, and then append an additional matrix to the file that is offset one row below the first:

```

M = magic(3);
dlmwrite('myfile.txt', [M*5 M/5], ' ')

dlmwrite('myfile.txt', [M/3], '-append', ...
 'roffset', 1, 'delimiter', ' ')

```

```
type myfile.txt
```

```

40 5 30 1.6 0.2 1.2
15 25 35 0.6 1 1.4
20 45 10 0.8 1.8 0.4

```

```

2.6667 0.33333 2
1 1.6667 2.3333
1.3333 3 0.66667

```

When dlmread imports these two matrices from the file, it pads the smaller matrix with zeros:

```

dlmread('myfile.txt')
 40.0000 5.0000 30.0000 1.6000 0.2000 1.2000

```

# d1mread

---

|         |         |         |        |        |        |
|---------|---------|---------|--------|--------|--------|
| 15.0000 | 25.0000 | 35.0000 | 0.6000 | 1.0000 | 1.4000 |
| 20.0000 | 45.0000 | 10.0000 | 0.8000 | 1.8000 | 0.4000 |
| 2.6667  | 0.3333  | 2.0000  | 0      | 0      | 0      |
| 1.0000  | 1.6667  | 2.3333  | 0      | 0      | 0      |
| 1.3333  | 3.0000  | 0.6667  | 0      | 0      | 0      |

## See Also

[dlmwrite](#) | [textscan](#) | [readtable](#)

## Purpose

Write matrix to ASCII-delimited file

## Syntax

```
dlmwrite(filename,M)
dlmwrite(filename,M,'-append')

dlmwrite(___,Name,Value)

dlmwrite(filename,M,delimiter)
dlmwrite(filename,M,delimiter,row,col)
```

## Description

`dlmwrite(filename,M)` writes numeric data in array `M` to an ASCII format file, `filename`, using the default delimiter (`,`) to separate array elements. If the file, `filename`, already exists, `dlmwrite` overwrites the file.

`dlmwrite(filename,M,'-append')` appends the data to the end of the existing file, `filename`.

`dlmwrite(___,Name,Value)` additionally specifies delimiter, newline character, offset, and precision options using one or more name-value pair arguments.

`dlmwrite(filename,M,delimiter)` writes array `M` to the file, `filename`, using the specified delimiter, `delimiter`, to separate array elements.

`dlmwrite(filename,M,delimiter,row,col)` writes the array starting at the specified row and column `row` and `col`, in the destination file. Empty elements separated by `delimiter` fill the leading rows and columns.

## Input Arguments

### **filename** - Name of file to write

string

Name of file to write, specified as a string.

**Example:** 'myFile.txt'

## Data Types

char

## **M - Numeric data to write**

matrix | cell array of numeric values

Numeric data to write, specified as a matrix or a cell array of numeric values with one value per cell.

**Example:** [1,2,3;4,5,6]

**Example:** {1,2,3;4,5,6}

## Data Types

single | double | int8 | int16 | int32 | int64 | uint8 |  
uint16 | uint32 | uint64 | logical | cell

**Complex Number Support:** Yes

## **delimiter - Delimiter to separate array elements**

',' (default) | string

Delimiter to separate array elements, specified as a string containing a single character or control character. Use '\t' to produce tab-delimited files.

**Example:** ';'

**Example:** '\t'

## Data Types

char

## **row - Row offset**

0 (default) | scalar

Row offset, specified as a scalar. The row offset indicates the number of rows to skip before writing the numeric data. `row` is zero-based, so that `row = 0` instructs MATLAB to begin writing in the first row of the destination file. Skipped rows are populated with the specified delimiter.

**col - Column offset**

0 (default) | scalar

Column offset, specified as a scalar. The column offset indicates the number of columns to skip before writing the numeric data. `col` is zero-based, so that `col = 0` instructs MATLAB to begin writing in the first column of the destination file. Skipped columns are separated with the specified delimiter.

**Name-Value Pair Arguments**

Specify optional comma-separated pairs of `Name,Value` arguments. `Name` is the argument name and `Value` is the corresponding value. `Name` must appear inside single quotes ( ' '). You can specify several name and value pair arguments in any order as `Name1,Value1,...,NameN,ValueN`.

**Example:**

```
dlmwrite('myFile.txt',M,'precision',4,'delimiter',' ') writes
the numeric values in array M with four significant digits and
delimited using the whitespace character.
```

**'delimiter' - Delimiter to separate array elements**

' , ' (default) | string

Delimiter to separate array elements, specified as the comma-separated pair consisting of `'delimiter'` and string containing a single character or control character. Use `'\t'` to produce tab-delimited files.

**Example:** `'delimiter',';'`

**Example:** `'delimiter','\t'`

**Data Types**

char

**'roffset' - Row offset**

0 (default) | scalar

Row offset, specified as the comma-separated pair consisting of `'roffset'` and a scalar. The row offset indicates the number of rows to

skip before writing the numeric data. These rows are populated with the specified delimiter. When appending to an existing file, the new data is offset from the end of the existing data.

The row offset is zero-based, so that `'roffset',0` instructs MATLAB to begin writing in the first row of the destination file, which is the default. However, when appending to a file, `'roffset',0` instructs MATLAB to begin writing in the first row immediately following existing data.

**Example:** `'roffset',2`

### **'offset' - Column offset**

0 (default) | scalar

Column offset from the left side of the destination file, specified as the comma-separated pair consisting of `'offset'` and a scalar. The column offset indicates the number of columns to skip before writing the numeric data. These columns are separated with the specified delimiter.

The column offset is zero-based, so that `'offset',0` instructs MATLAB to begin writing in the first column of the destination file, which is the default.

**Example:** `'offset',1`

### **'precision' - Numeric precision**

5 (default) | scalar | C-style format string

Numeric precision to use in writing data to the file, specified as the comma-separated pair consisting of `'precision'` and a scalar or a C-style format string that begins with %, such as `'%10.5f'`. If the value of precision is a scalar, then it indicates the number of significant digits.

**Example:** `'precision',3`

**Example:** `'precision','%10.5f'`

### **Data Types**

single | double | int8 | int16 | int32 | int64 | uint8 |  
uint16 | uint32 | uint64 | char

**'newline' - Line terminator**`'pc' | 'unix'`

Line terminator, specified as the comma-separated pair consisting of 'newline' and either 'pc' to use a carriage return/line feed (CR/LF), or 'unix' to use a line feed (LF).

**Example:** 'newline', 'pc'

**Examples****Write Comma-Separated Data**

Create an array of sample data, M.

```
M = magic(3);
```

Write matrix M to a file, 'myFile.txt', using the default delimiter (,).

```
dlmwrite('myFile.txt',M)
```

View the data in the file.

```
type('myFile.txt')
```

```
8,1,6
```

```
3,5,7
```

```
4,9,2
```

**Write Tab-Delimited Data and Specify Precision**

Create an array of sample data, M.

```
M = magic(3)*pi
```

```
M =
```

```
25.1327 3.1416 18.8496
```

```
9.4248 15.7080 21.9911
```

```
12.5664 28.2743 6.2832
```

# dlmwrite

---

Write matrix `M` to a file, `'myFile.txt'`, delimited by the tab character and using a precision of 3 significant digits.

```
dlmwrite('myFile.txt',M,'delimiter','\t','precision',3)
```

View the data in the file.

```
type('myFile.txt')
```

```
25.1 3.14 18.8
9.42 15.7 22
12.6 28.3 6.28
```

## Write and Append Data to File

Create two arrays of sample numeric data.

```
M = magic(5);
N = magic(3);
```

Export matrix `M` to a file and use whitespace as the delimiter.

```
dlmwrite('myFile.txt',M,'delimiter',' ');
```

Append matrix `N` to the file, offset from the existing data by one row. Then, view the file.

```
dlmwrite('myFile.txt',N,'-append',...
'delimiter',' ','roffset',1)
type('myFile.txt')
```

```
17 24 1 8 15
23 5 7 14 16
4 6 13 20 22
10 12 19 21 3
11 18 25 2 9
```

```
8 1 6
3 5 7
```



```
4 9 2
```

Read the data in 'myFile.txt' using dlmread.

```
dlmread('myFile.txt')
```

```
ans =
```

```
 17 24 1 8 15
 23 5 7 14 16
 4 6 13 20 22
 10 12 19 21 3
 11 18 25 2 9
 8 1 6 0 0
 3 5 7 0 0
 4 9 2 0 0
```

When dlmread reads the two matrices from the file, it pads the smaller matrix with zeros.

### Write Data and Specify Precision As String

Create an array of sample numeric data.

```
M = magic(3);
```

Export matrix M to a file using a precision of 6 decimal places.

```
dlmwrite('myFile.txt',M,'precision','%.6f');
```

View the data in the file.

```
type('myFile.txt')
```

```
8.000000,1.000000,6.000000
3.000000,5.000000,7.000000
4.000000,9.000000,2.000000
```

# dlmwrite

---

## Tips

- `dlmwrite` writes a file that spreadsheet programs can read. Alternatively, if your system has Excel for Windows installed, you can create a spreadsheet using `xlswrite`.

## See Also

`dlmread` | `xlswrite` | `writetable`

**Purpose** Dulmage-Mendelsohn decomposition

**Syntax**  $p = \text{dmperm}(A)$   
 $[p,q,r,s,cc,rr] = \text{dmperm}(A)$

**Description**  $p = \text{dmperm}(A)$  finds a vector  $p$  such that  $p(j) = i$  if column  $j$  is matched to row  $i$ , or zero if column  $j$  is unmatched. If  $A$  is a square matrix with full structural rank,  $p$  is a maximum matching row permutation and  $A(p, :)$  has a zero-free diagonal. The structural rank of  $A$  is  $\text{sprank}(A) = \text{sum}(p > 0)$ .

$[p,q,r,s,cc,rr] = \text{dmperm}(A)$  where  $A$  need not be square or full structural rank, finds the Dulmage-Mendelsohn decomposition of  $A$ .  $p$  and  $q$  are row and column permutation vectors, respectively, such that  $A(p,q)$  has a block upper triangular form.  $r$  and  $s$  are index vectors indicating the block boundaries for the fine decomposition.  $cc$  and  $rr$  are vectors of length five indicating the block boundaries of the coarse decomposition.

$C = A(p,q)$  is split into a 4-by-4 set of coarse blocks:

```
A11 A12 A13 A14
0 0 A23 A24
0 0 0 A34
0 0 0 A44
```

where  $A12$ ,  $A23$ , and  $A34$  are square with zero-free diagonals. The columns of  $A11$  are the unmatched columns, and the rows of  $A44$  are the unmatched rows. Any of these blocks can be empty. In the coarse decomposition, the  $(i,j)$ th block is  $C(rr(i):rr(i+1)-1,cc(j):cc(j+1)-1)$ . For a linear system,

- $[A11 \ A12]$  is the underdetermined part of the system—it is always rectangular and with more columns and rows, or 0-by-0,
- $A23$  is the well-determined part of the system—it is always square, and

- [A34 ; A44] is the overdetermined part of the system—it is always rectangular with more rows than columns, or 0-by-0.

The structural rank of A is  $\text{sprank}(A) = \text{rr}(4) - 1$ , which is an upper bound on the numerical rank of A.  $\text{sprank}(A) = \text{rank}(\text{full}(\text{sprand}(A)))$  with probability 1 in exact arithmetic.

The A23 submatrix is further subdivided into block upper triangular form via the fine decomposition (the strongly connected components of A23). If A is square and structurally nonsingular, A23 is the entire matrix.

$C(r(i):r(i+1)-1, s(j):s(j+1)-1)$  is the  $(i, j)$ th block of the fine decomposition. The  $(1, 1)$  block is the rectangular block [A11 A12], unless this block is 0-by-0. The  $(b, b)$  block is the rectangular block [A34 ; A44], unless this block is 0-by-0, where  $b = \text{length}(r) - 1$ . All other blocks of the form  $C(r(i):r(i+1)-1, s(i):s(i+1)-1)$  are diagonal blocks of A23, and are square with a zero-free diagonal.

## Tips

If A is a reducible matrix, the linear system  $Ax=b$  can be solved by permuting A to a block upper triangular form, with irreducible diagonal blocks, and then performing block backsubstitution. Only the diagonal blocks of the permuted matrix need to be factored, saving fill and arithmetic in the blocks above the diagonal.

In graph theoretic terms, dmperm finds a maximum-size matching in the bipartite graph of A, and the diagonal blocks of  $A(p, q)$  correspond to the strong Hall components of that graph. The output of dmperm can also be used to find the connected or strongly connected components of an undirected or directed graph. For more information see Pothen and Fan [1].

## References

[1] Pothen, Alex and Chin-Ju Fan “Computing the Block Triangular Form of a Sparse Matrix” *ACM Transactions on Mathematical Software* Vol 16, No. 4 Dec. 1990, pp. 303-324.

## See Also

sprank

---

|                        |                                                                                                                                                                                                                                                                                                                                                                                                                                                                                                                                                                                                                                                                                                                                                                                                                                                                                                                                                                                                                                                                                    |
|------------------------|------------------------------------------------------------------------------------------------------------------------------------------------------------------------------------------------------------------------------------------------------------------------------------------------------------------------------------------------------------------------------------------------------------------------------------------------------------------------------------------------------------------------------------------------------------------------------------------------------------------------------------------------------------------------------------------------------------------------------------------------------------------------------------------------------------------------------------------------------------------------------------------------------------------------------------------------------------------------------------------------------------------------------------------------------------------------------------|
| <b>Purpose</b>         | Reference page in Help browser                                                                                                                                                                                                                                                                                                                                                                                                                                                                                                                                                                                                                                                                                                                                                                                                                                                                                                                                                                                                                                                     |
| <b>Syntax</b>          | <code>doc</code><br><code>doc name</code>                                                                                                                                                                                                                                                                                                                                                                                                                                                                                                                                                                                                                                                                                                                                                                                                                                                                                                                                                                                                                                          |
| <b>Description</b>     | <p><code>doc</code> opens the Help browser. If the Help browser is already open, but not visible, then <code>doc</code> brings it to the foreground and opens a new tab.</p> <p><code>doc name</code> displays documentation for the functionality specified by <code>name</code>, such as a function, class, or block.</p> <ul style="list-style-type: none"><li>• If there is a MathWorks reference page corresponding to <code>name</code>, then <code>doc</code> displays the page in the Help browser. The <code>doc</code> command does not display third-party or custom HTML documentation.</li><li>• If there is no reference page corresponding to <code>name</code>, then <code>doc</code> searches for help text in a file named <code>name.m</code>. When help text is available, <code>doc</code> displays it in the Help browser.</li><li>• If there is no reference page and no help text associated with <code>name</code>, then <code>doc</code> searches the documentation for <code>name</code> and displays the search results in the Help browser.</li></ul> |
| <b>Input Arguments</b> | <p><b>name - Name of function, class, block, or other functionality</b><br/><code>string</code></p> <p>Name of a function, class, block, or other functionality, specified as a string. Alternatively, an operator symbol.</p> <p>Some classes and other packaged items require that you specify the package name. Events, properties, and some methods require that you specify the class name. Separate the components of the name with periods, such as:</p> <pre>doc className.name<br/>doc packageName.name<br/>doc packageName.className.name</pre>                                                                                                                                                                                                                                                                                                                                                                                                                                                                                                                          |

Methods for some classes are not accessible using the `doc` command; instead, use links on the class reference page.

## **Examples**      **Function Reference Pages**

Display the reference page for the `abs` function.

```
doc abs
```

Several products include different versions of `abs`. If your Help preferences support displaying documentation for those products, then the Help browser displays the MATLAB `abs` reference page and a message with links to other versions of `abs`. This message appears at the top of the page.

## **Class and Method Reference Pages**

Display the reference page for the `handle` class.

```
doc handle
```

Display the reference page for the `findobj` method in the `handle` class.

```
doc handle.findobj
```

Display the reference page for the `Map` class in the `containers` package.

```
doc containers.Map
```

## **Custom Class Pages**

Display formatted help text for a custom class.

MATLAB includes a set of example files that show how to create a class, including a class file named `sads.m`. Add the example folder to the path, and request documentation for `sads`.

```
addpath(...
 fullfile(matlabroot, 'help', 'techdoc', 'matlab_env', ...
 'examples'))
doc sads
```

---

Display the help for the `steer` method of the `sads` class.

```
doc sads.steer
```

Because the help text follows MATLAB conventions, MATLAB formats the display in the browser.

### Tips

- To access third-party or custom documentation, open the Help browser and navigate to the documentation home page. Then, at the bottom of the page, click **Supplemental Software**.

### See Also

help | web

### Concepts

- “Ways to Get Function Help”
- “Add Help for Your Program”
- “Display Custom Documentation”

# docsearch

---

**Purpose** Help browser search

**Syntax** docsearch  
docsearch expression

**Description** docsearch opens the Help browser and displays the documentation home page. If the Help browser is already open, but not visible, then docsearch brings it to the foreground.

docsearch expression searches MathWorks documentation for pages with words that match the specified expression and highlights them. To clear highlighting, press the **Esc** key. The docsearch command does not search third-party or custom documentation.

## Input Arguments

**expression - Expression that defines search terms**  
string

Expression that defines search terms, specified as a string. Expressions can include:

- Quotation marks to specify exact phrases, such as "plot tools".
- Boolean operator keywords in uppercase (listed here in order of precedence): NOT, OR, AND.
- Asterisk (\*) wildcard characters, except at the beginning of a word or in an exact phrase. Searches require that at least two characters in the expression are *not* wildcard characters.

## Examples

### Single Words

Find all documentation pages that contain the word *plot*.

```
docsearch plot
```

### Multiple Words

Find documentation pages with the words *plot* and *tools*.

```
docsearch plot tools
```



Expand the search to include variations of the word *plot*, such as *plotting* or *plots*, using a wildcard character.

```
docsearch plot* tools
```

Narrow the search to pages that include an exact phrase by enclosing the phrase in quotation marks.

```
docsearch "plot tools"
```

Find pages with either word, but not necessarily both words, using the OR operator.

```
docsearch plot OR tools
```

### Tips

- To access third-party or custom documentation, open the Help browser and navigate to the documentation home page. Then, at the bottom of the page, click **Supplemental Software**.

### See Also

`builddocsearchdb | doc`

### Concepts

- “Search Syntax and Tips”

# dos

---

## Purpose

Execute DOS command and return output

## Syntax

```
status = dos(command)
[status,cmdout] = dos(command)
[status,cmdout] = dos(command, '-echo')
```

## Description

`status = dos(command)` executes the specified DOS command for Windows platforms, and waits for the command to finish execution before returning the exit status to the `status` variable.

`[status,cmdout] = dos(command)` additionally returns the output of the DOS command to `cmdout`. This syntax is most useful for DOS console commands that do not require user input, such as `dir`.

`[status,cmdout] = dos(command, '-echo')` additionally displays (echoes) the command output in the MATLAB Command Window. This syntax is most useful for DOS console commands that require user input and that run correctly in the MATLAB Command Window, such as `comp`.

## Input Arguments

### **command** - MS-DOS® command

string

MS-DOS command, specified as a string. The command can be a Windows UI program that opens a graphical user interface, or a DOS console command that you typically run in a DOS command window. The command executes in a DOS shell, which might not be the shell from which you launched MATLAB.

**Example:** 'dir'

## Output Arguments

### **status** - Command exit status

0 | nonzero integer

Command exit status, returned as either 0 or a nonzero integer. When the command is successful, `status` is 0. Otherwise, `status` is a nonzero integer.

- If command includes the ampersand character (&), then `status` is the exit status upon command launch.
- If command does not include the ampersand character (&), then `status` is the exit status upon command completion.

### **cmdout - Output of operating system command**

string

Output of the operating system command, returned as a string.

## **Limitations**

- DOS does not support UNC path names. Therefore, if the current folder uses a UNC path name, then running `dos` with a DOS command that relies on the current folder fails. MATLAB returns this error:

```
Error using dos
DOS commands may not be executed when the current directory is a UNC
```

To work around this limitation, change the folder to a mapped drive before running `dos` or a function that calls `dos`.

## **Examples**

### **Save DOS Command Exit Status**

Issue a DOS command to create a new folder named `mynew` and save the exit status to a variable.

```
command = 'mkdir mynew';
status = dos(command)
```

```
status =
```

```
0
```

The `status` of zero indicates that the `mynew` folder was created successfully.

## Open and Run a Windows UI Command

Open Notepad and immediately return the exit status to MATLAB by appending an ampersand (&) to the notepad command.

```
status = dos('notepad &')
```

```
status =
```

```
0
```

The status of zero indicates that Notepad successfully started.

## Save Successful DOS Command Status and Output

Execute the DOS command, `dir`, and view the exit status and command output.

```
[status,cmdout] = dos('dir');
```

```
status, cmdout
```

```
status =
```

```
0
```

```
cmdout =
```

```
Volume in drive C is OSDisk
Volume Serial Number is XXX-XXXX
```

```
Directory of C:\my_MATLAB_files
```

```
04/10/2012 12:08 PM <DIR> .
04/10/2012 12:08 PM <DIR> ..
04/21/2011 09:24 AM 171 base.mat
02/08/2010 05:14 PM 73 baseball.dat
04/10/2012 12:08 PM 474 collatz.asv
04/10/2012 11:56 AM 480 collatz.m
```

```
.
. .
. . .
```

When you issue a valid DOS command, `status` indicates success and `cmdout` contains the command output.

### **Save Unsuccessful DOS Command Status and Output**

Attempt to execute a command called `foo`. Then, view the status and results output arguments.

```
[status,results] = dos('foo');
status, results
```

```
status =
```

```
1
```

```
results =
```

```
'foo' is not recognized as an internal or external command,
operable program or batch file.
```

When you issue an invalid DOS command, `status` indicates failure and `results` contains the DOS error message.

### **Display DOS Command Output in MATLAB Command Window**

Display command output and prompts in the Command Window as the command executes, and also assign the command output to the `results` variable.

```
[status,results] = dos('comp', '-echo');
```

```
Name of first file to compare: collatz.m
collatz.m
```

```
Name of second file to compare: collatz.asv
collatz.asv
Option: /A
/A
Option:

Comparing collatz.m and collatz.asv...
Files compare OK

Compare more files (Y/N) ? N
N
>>
```

## Tips

- To execute the operating system command in the background, include the trailing character, `&`, in the command argument (for example, `'notepad &'`). The exit status is immediately returned to the status variable. This syntax is useful for console programs that require interactive user command input while they run, and that do not run correctly in the MATLAB Command Window.

---

**Note** If command includes the trailing `&` character, then `cmdout` is empty.

---

## See Also

`computer` | `perl` | `system` | `unix` | ! (exclamation point)

**Purpose**

Dot product

**Syntax**

$C = \text{dot}(A,B)$   
 $C = \text{dot}(A,B,\text{dim})$

**Description**

$C = \text{dot}(A,B)$  returns the scalar dot product of A and B.

- If A and B are vectors, then they must have the same length.
- If A and B are matrices or multidimensional arrays, then they must have the same size. In this case, the dot function treats A and B as collections of vectors. The function calculates the dot product of corresponding vectors along the first array dimension whose size does not equal 1.

$C = \text{dot}(A,B,\text{dim})$  evaluates the dot product of A and B along dimension, dim. The dim input is a positive integer scalar.

**Input Arguments****A,B - Input arrays**

numeric arrays

Input arrays, specified as numeric arrays.

**Data Types**

single | double

**Complex Number Support:** Yes

**dim - Dimension to operate along**

positive integer scalar

Dimension to operate along, specified as a positive integer scalar. If no value is specified, the default is the first array dimension whose size does not equal 1.

Consider two 2-D input arrays, A and B:

- $\text{dot}(A,B,1)$  treats the columns of A and B as vectors and returns the dot products of corresponding columns.

- `dot(A,B,2)` treats the rows of A and B as vectors and returns the dot products of corresponding rows.

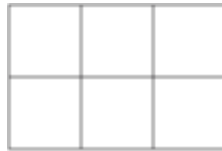

A

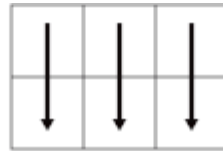

`dot(A,B,1)`

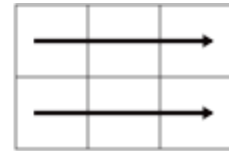

`dot(A,B,2)`

`dot` returns `conj(A) .* B` if `dim` is greater than `ndims(A)`.

## Examples

### Dot Product of Real Vectors

Create two simple, three-element vectors.

```
A = [4 -1 2];
B = [2 -2 -1];
```

Calculate the dot product of A and B.

```
C = dot(A,B)
```

```
C =
```

```
8
```

The result is 8 since

$$C = A(1) * B(1) + A(2) * B(2) + A(3) * B(3)$$
$$C = 8 + 2 - 2.$$

### Dot Product of Complex Vectors

Create two complex vectors.

```
A = [1+i 1-i -1+i -1-i];
B = [3-4i 6-2i 1+2i 4+3i];
```



Calculate the dot product of A and B.

`C = dot(A,B)`

`C =`

```
1.0000 - 5.0000i
```

The result is a complex scalar since A and B are complex. In general, the dot product of two complex vectors is also complex. An exception is when you take the dot product of a complex vector with itself.

Find the inner product of A with itself.

`D = dot(A,A)`

`D =`

```
8
```

The result is a real scalar. The inner product of a vector with itself is related to the Euclidean length of the vector,  $\text{norm}(A)$ .

### **Dot Product of Matrices**

Create two matrices.

`A = [1 2 3;4 5 6;7 8 9];`

`B = [9 8 7;6 5 4;3 2 1];`

Find the dot product of A and B.

`C = dot(A,B)`

`C =`

```
54 57 54
```

The result, C, contains three separate dot products. `dot` treats the columns of A and B as vectors and calculates the dot product of

corresponding columns. So, for example,  $C(1) = 54$  is the dot product of  $A(:,1)$  with  $B(:,1)$ .

Find the dot product of A and B, treating the *rows* as vectors.

```
D = dot(A,B,2)
```

```
D =
```

```
46
73
46
```

In this case,  $D(1) = 46$  is the dot product of  $A(1,:)$  with  $B(1,:)$ .

## Dot Product of Multidimensional Arrays

Create two multidimensional arrays.

```
A = cat(3,[1 1;1 1],[2 3;4 5],[6 7;8 9])
```

```
B = cat(3,[2 2;2 2],[10 11;12 13],[14 15; 16 17])
```

```
A(:,:,1) =
```

```
1 1
1 1
```

```
A(:,:,2) =
```

```
2 3
4 5
```

```
A(:,:,3) =
```

```
6 7
8 9
```

$$B(:, :, 1) =$$

$$\begin{array}{cc} 2 & 2 \\ 2 & 2 \end{array}$$

$$B(:, :, 2) =$$

$$\begin{array}{cc} 10 & 11 \\ 12 & 13 \end{array}$$

$$B(:, :, 3) =$$

$$\begin{array}{cc} 14 & 15 \\ 16 & 17 \end{array}$$

Calculate the dot product of A and B along the third dimension (dim = 3).

$$C = \text{dot}(A, B, 3)$$

$$C =$$

$$\begin{array}{cc} 106 & 140 \\ 178 & 220 \end{array}$$

The result, C, contains four separate dot products. The first dot product,  $C(1, 1) = 106$ , is equal to the dot product of  $A(1, 1, :)$  with  $B(1, 1, :)$ .

## Definitions

### Scalar Dot Product

The scalar dot product of two real vectors of length  $n$  is equal to

$$u \cdot v = \sum_{i=1}^n u_i v_i = u_1 v_1 + u_2 v_2 + \dots + u_n v_n.$$

# dot

---

This relation is commutative for real vectors, such that `dot(u,v)` equals `dot(v,u)`. If the dot product is equal to zero, then  $u$  and  $v$  are perpendicular.

For complex vectors, the dot product involves a complex conjugate. This ensures that the inner product of any vector with itself is real and positive definite.

$$u \cdot v = \sum_{i=1}^n \bar{u}_i v_i.$$

Unlike the relation for real vectors, the complex relation is not commutative, so `dot(u,v)` equals `conj(dot(v,u))`.

## Algorithms

- When inputs  $A$  and  $B$  are real or complex vectors, the dot function treats them as column vectors and `dot(A,B)` is the same as `sum(conj(A).*B)`.
- When the inputs are matrices or multidimensional arrays, the `dim` argument determines which dimension the sum function operates on. In this case, `dot(A,B)` is the same as `sum(conj(A).*B,dim)`.

## See Also

`cross` | `sum` | `conj`

**Purpose** Convert to double precision

**Syntax** `double(x)`

**Description** `double(x)` returns the double-precision value for *X*. If *X* is already a double-precision array, `double` has no effect.

**Tips** The `double` function should be overloaded for any object when it makes sense to convert it to a double-precision value.

# dragrect

---

**Purpose** Drag rectangles with mouse

**Syntax** `[finalrect] = dragrect(initialrect)`  
`[finalrect] = dragrect(initialrect,stepsize)`

**Description** `[finalrect] = dragrect(initialrect)` tracks one or more rectangles anywhere on the screen. The n-by-4 matrix `initialrect` defines the rectangles. Each row of `initialrect` must contain the initial rectangle position as `[left bottom width height]` values. `dragrect` returns the final position of the rectangles in `finalrect`.

`[finalrect] = dragrect(initialrect,stepsize)` moves the rectangles in increments of `stepsize`. The lower left corner of the first rectangle is constrained to a grid of size equal to `stepsize` starting at the lower left corner of the figure, and all other rectangles maintain their original offset from the first rectangle.

`[finalrect] = dragrect(...)` returns the final positions of the rectangles when the mouse button is released. The default step size is 1.

**Tips** `dragrect` returns immediately if a mouse button is not currently pressed. Use `dragrect` in a `ButtonDownFcn`, or from the command line in conjunction with `waitforbuttonpress`, to ensure that the mouse button is down when `dragrect` is called. `dragrect` returns when you release the mouse button.

If the drag ends over a figure window, the positions of the rectangles are returned in that figure's coordinate system. If the drag ends over a part of the screen not contained within a figure window, the rectangles are returned in the coordinate system of the figure over which the drag began.

---

**Note** You cannot use normalized figure units with `dragrect`.

---

## Examples

Drag a rectangle that is 50 pixels wide and 100 pixels in height.

```
waitforbuttonpress
point1 = get(gcf, 'CurrentPoint') % button down detected
rect = [point1(1,1) point1(1,2) 50 100]
[r2] = dragrect(rect)
```

## See Also

[rbbox](#) | [waitforbuttonpress](#)

# drawnow

---

**Purpose** Update figure window and execute pending callbacks

**Syntax** drawnow  
drawnow expose  
drawnow update

**Description** drawnow causes figure windows and their children to update. Any callbacks generated by user actions (for example, mouse or key presses, button clicks, and so on) are executed before drawnow returns.

Use drawnow in animation loops to update the figure during function execution and to update graphical user interfaces.

drawnow expose causes graphics and user-interface objects to refresh with all pending changes. However, it does not allow pending callbacks to execute.

drawnow update causes only user-interface objects to refresh. It does not allow pending callbacks to execute and does not refresh graphics objects.

---

**Note** On Macintosh systems, drawnow update produces the same results as described for drawnow expose

---

## Other Actions That Cause Queue Processing

Other actions and function calls that cause the MATLAB software to flush the queue and update the figure include:

- Returning to the MATLAB prompt
- Executing the following functions:
  - figure
  - getframe
  - input
  - pause



- keyboard
- Functions that wait for user input (i.e., `waitforbuttonpress`, `waitfor`, `ginput`)
- Any code that causes one of the above functions to execute. For example, suppose `h` is the handle of an axes. Calling `axes(h)` causes its parent figure to be made the current figure and brought to the front of all displayed figures, which is the equivalent of executing a `drawnow`.

## Examples

Using `drawnow` in a loop causes the display to update while the loop executes:

```
t = 0:pi/100:2*pi;
y = exp(sin(t));
h = plot(t,y,'YDataSource','y');
for k = 1:0.01:10
 y = exp(sin(t.*k));
 refreshdata(h,'caller')
 drawnow
end
```

## See Also

`snapnow` | `waitfor` | `waitforbuttonpress`

# dsearchn

---

**Purpose** N-D nearest point search

**Syntax**  
`k = dsearchn(X,T,XI)`  
`k = dsearchn(X,T,XI,outval)`  
`k = dsearchn(X,XI)`  
`[k,d] = dsearchn(X,...)`

**Description** `k = dsearchn(X,T,XI)` returns the indices `k` of the closest points in `X` for each point in `XI`. `X` is an `m`-by-`n` matrix representing `m` points in `n`-dimensional space. `XI` is a `p`-by-`n` matrix, representing `p` points in `n`-dimensional space. `T` is a `numt`-by-`n+1` matrix, a triangulation of the data `X` generated by `delaunayn`. The output `k` is a column vector of length `p`.

`k = dsearchn(X,T,XI,outval)` returns the indices `k` of the closest points in `X` for each point in `XI`, unless a point is outside the convex hull. If `XI(J,:)` is outside the convex hull, then `K(J)` is assigned `outval`, a scalar double. `Inf` is often used for `outval`. If `outval` is `[]`, then `k` is the same as in the case `k = dsearchn(X,T,XI)`.

`k = dsearchn(X,XI)` performs the search without using a triangulation. With large `X` and small `XI`, this approach is faster and uses much less memory.

`[k,d] = dsearchn(X,...)` also returns the distances `d` to the closest points. `d` is a column vector of length `p`.

**Algorithms** `dsearchn` is based on Qhull [1]. For information about Qhull, see <http://www.qhull.org/>. For copyright information, see <http://www.qhull.org/COPYING.txt>.

**References** [1] Barber, C. B., D.P. Dobkin, and H.T. Huhdanpaa, "The Quickhull Algorithm for Convex Hulls," *ACM Transactions on Mathematical Software*, Vol. 22, No. 4, Dec. 1996, p. 469–483.

**See Also** `delaunayTriangulation`

**Purpose** Abstract class used to derive handle class with dynamic properties

**Syntax** `classdef myclass < dynamicprops`

**Description** `classdef myclass < dynamicprops` makes *myclass* a subclass of the `dynamicprops` class, which is a subclass of the `handle` class.

Use the `dynamicprops` class to derive classes that can define dynamic properties (instance properties), which are associated with a specific objects, but have no effect on the objects class definition. Dynamic properties are useful for attaching temporary data to one or more objects.

### **dynamicprops Methods**

This class defines one method `addprop` and, as a subclass of the `handle` class, inherits all the `handle` class methods.

- `addprop` — adds the named property to the specified handle objects. See “Dynamic Properties — Adding Properties to an Instance” for more information.

**See Also** `handle`

# echo

---

**Purpose** Display statements during function execution

**Syntax**

```
echo on
echo off
echo
echo fcnname on
echo fcnname off
echo fcnname
echo on all
echo off all
```

**Description** The echo command controls the display (or *echoing*) of statements in a function during their execution. Normally, statements in a function file are not displayed on the screen during execution. Command echoing is useful for debugging or for demonstrations, allowing the commands to be viewed as they execute.

The echo command behaves in a slightly different manner for script files and function files. For script files, the use of echo is simple; echoing can be either on or off, in which case any script used is affected.

|          |                                                       |
|----------|-------------------------------------------------------|
| echo on  | Turns on the echoing of commands in all script files  |
| echo off | Turns off the echoing of commands in all script files |
| echo     | Toggles the echo state                                |

With function files, the use of echo is more complicated. If echo is enabled on a function file, the file is interpreted, rather than compiled. Each input line is then displayed as it is executed. Since this results in inefficient execution, use echo only for debugging.

|                         |                                              |
|-------------------------|----------------------------------------------|
| echo <i>fcnname</i> on  | Turns on echoing of the named function file  |
| echo <i>fcnname</i> off | Turns off echoing of the named function file |

|                                  |                                                   |
|----------------------------------|---------------------------------------------------|
| <code>echo <i>fcnname</i></code> | Toggles the echo state of the named function file |
| <code>echo on all</code>         | Sets echoing on for all function files            |
| <code>echo off all</code>        | Sets echoing off for all function files           |

## Tips

- To avoid confusing syntax, do not use `on` or `off` as a function name.

## See Also

`function`

# echodemo

---

**Purpose** Run example script step-by-step in Command Window

**Syntax**  
`echodemo filename`  
`echodemo(filename,index)`

**Description** `echodemo filename` runs the script specified by `filename` step-by-step in the Command Window. The file must contain sections defined with two percent signs (%) to enable pausing after each step. At each step, you can click links in the Command Window to proceed or stop. If the Command Window is not large enough to show the links, scroll up to see them.

---

## Caution

If variables in your base workspace have the same name as variables that the example file creates, the example could overwrite your data. Preserve your data by saving it to a MAT-file before running the example.

---

`echodemo(filename,index)` starts with the section number specified by `index`. If the example relies on results of previous steps, using this syntax can produce errors or unexpected results.

## Input Arguments

### **filename - Script file name**

string

Script file name, specified as a string.

When you use the function syntax for `echodemo` and specify its inputs within parentheses, enclose the `filename` input in single quotes.

### **index - Section index**

scalar integer

Section index, specified as a scalar integer.

The link text in the Command Window shows the current section number,  $n$ , and the total number of sections,  $m$ , as  $n/m$ .

## Examples

### Run Example Script in Command Window

Run the Loma Prieta Earthquake example.

```
echodemo quake
```

### Start Script from Specified Section

Start the Loma Prieta Earthquake example from the third section.

```
filename = 'quake';
index = 3;
echodemo(filename,index)
```

This code errors because the example requires variables created in earlier sections.

## Tips

- Only use `echodemo` to display scripts, not functions. `echodemo` can run any script that you can execute, but only scripts with sections pause between steps.

## See Also

[demo](#) | [doc](#) | [publish](#)

# TriRep.edgeAttachments

---

**Purpose** (Will be removed) Simplices attached to specified edges

---

**Note** `edgeAttachments(TriRep)` will be removed in a future release. Use `edgeAttachments(triangulation)` instead.

---

`TriRep` will be removed in a future release. Use `triangulation` instead.

---

**Syntax**  
`SI = edgeAttachments(TR, V1, V2)`  
`SI = edgeAttachments(TR, EDGE)`

**Description**  
`SI = edgeAttachments(TR, V1, V2)` returns the simplices `SI` attached to the edges specified by `(V1, V2)`. `(V1, V2)` represents the start and end vertices of the edges to be queried.  
`SI = edgeAttachments(TR, EDGE)` specifies edges in matrix format.

**Input Arguments**

|                     |                                                                                                                                                    |
|---------------------|----------------------------------------------------------------------------------------------------------------------------------------------------|
| <code>TR</code>     | Triangulation representation.                                                                                                                      |
| <code>V1, V2</code> | Column vectors of vertex indices into the array of points representing the vertex coordinates.                                                     |
| <code>EDGE</code>   | Matrix specifying edge start and end points. <code>EDGE</code> is of size <code>m-by-2</code> , <code>m</code> being the number of edges to query. |

**Output Arguments**

|                 |                                                                                                                                                                 |
|-----------------|-----------------------------------------------------------------------------------------------------------------------------------------------------------------|
| <code>SI</code> | Vector cell array of indices into the triangulation matrix. <code>SI</code> is a cell array because the number of simplices associated with each edge can vary. |
|-----------------|-----------------------------------------------------------------------------------------------------------------------------------------------------------------|

**Definitions** A simplex is a triangle/tetrahedron or higher dimensional equivalent.

**Examples** **Example 1**

Load a 3-D triangulation to compute the tetrahedra attached to an edge.



```
load tetmesh
trep = TriRep(tet, X);
v1 = [15 21]';
v2 = [936 716]';
t1 = edgeAttachments(trep, v1, v2);
```

You can also specify the input as edges.

```
e = [v1 v2];
t2 = edgeAttachments(trep, e);
isequal(t1,t2);
```

## Example 2

Create a triangulation with `DelaunayTri`.

```
x = [0 1 1 0 0.5]';
y = [0 0 1 1 0.5]';
dt = DelaunayTri(x,y);
```

Query the triangles attached to edge (1,5).

```
t = edgeAttachments(dt, 1,5);
t{:};
```

## See Also

[edges](#) | [triangulation](#) | [delaunayTriangulation](#)

# TriRep.edges

---

**Purpose** (Will be removed) Triangulation edges

---

**Note** `edges(TriRep)` will be removed in a future release. Use `edges(triangulation)` instead.

---

`TriRep` will be removed in a future release. Use `triangulation` instead.

---

**Syntax** `E = edges(TR)`

**Description** `E = edges(TR)` returns the edges in the triangulation in an `n`-by-2 matrix. `n` is the number of edges. The vertices of the edges index into `TR.X`, the array of points representing the vertex coordinates.

**Input Arguments**

|                 |                               |
|-----------------|-------------------------------|
| <code>TR</code> | Triangulation representation. |
|-----------------|-------------------------------|

**Output Arguments**

|                |              |
|----------------|--------------|
| <code>E</code> | Edge matrix. |
|----------------|--------------|

**Examples**      **Example 1**

Load a 2-D triangulation.

```
load trimesh2d
trep = TriRep(tri, x,y);
```

Return all edges.

```
e = edges(trep);
```

**Example 2**

Query a 2-D DelaunayTri-generated triangulation.

```
X = rand(10,2);
```

```
dt = DelaunayTri(X);
e = edges(dt);
```

## See Also

[edgeAttachments](#) | [triangulation](#) | [delaunayTriangulation](#)

# edit

---

**Purpose** Edit or create file

**Syntax**

```
edit
edit file
edit file1 ... fileN
```

**Description** edit opens a new file called `Untitled` in the Editor. MATLAB does not automatically save `Untitled`.

`edit file` opens the specified file in the Editor. If `file` does not already exist, MATLAB asks if you want to create it. `file` can include a partial path, complete path, relative path, or no path. If `file` includes a partial path or no path, `edit` will look for the file on the search path. You must have write permission to the path to create `file`, otherwise, MATLAB ignores the argument.

You must specify the extension to open `.mat` and `.mdl` files. MATLAB cannot directly edit binary files, such as `.p` and `.mex` files.

`edit file1 ... fileN` opens each file, `file1 ... fileN`, in the Editor.

## Examples

### Open a New File

```
edit
```

A new file titled `Untitled` opens in the MATLAB Editor (or default editor). `Untitled` does not appear in your Current Folder.

### Create a New File

```
mkdir tests
edit tests/new_script.m
```

A dialog box appears, asking if you want to create `new_script.m`. If you select **Yes**, MATLAB creates and opens `tests/new_script.m`.

## Open Files

```
edit file1 file2 file3 file4
```

MATLAB sequentially creates and opens the files: `file1`, `file2`, `file3`, and `file4` in sequence.

## Input Arguments

### **file** - Name of file

string

Name of file, specified as a string. If `file` specifies a path that contains a nonexistent folder, MATLAB throws an error. Specify multiple files on the same line by separating filenames with a space.

If `file` is overloaded (that is, appears in multiple folders on the search path), then include a partial path to edit the correct page, such as

```
edit folderName/file
```

If you do not specify the extension, then `edit` opens a file with the specified name and a `.m` extension.

```
edit name
```

If the file is part of a class or package, then either specify the path and extension, or separate the components of the name with periods, such as:

```
edit className.name
edit packageName.name
edit packageName.className.name
edit packageName.name
```

### **Data Types**

char

## See Also

`open` | `type`

## Concepts

- “Change Default Editor”

**Purpose** Eigenvalues and eigenvectors

**Syntax** `lambda = eig(A)`  
`lambda = eig(A,balanceOption)`

`lambda = eig(A,B)`  
`lambda = eig(A,B,algorithm)`

`[V,D] = eig( __ )`  
`[V,D,W] = eig( __ )`

`[ __ ] = eig( __ ,eigvalOption)`

**Description** `lambda = eig(A)` returns a column vector containing the eigenvalues, with multiplicity, that satisfy the equation  $Av = \lambda v$ , where  $A$  is an  $n$ -by- $n$  matrix,  $v$  is a column vector of length  $n$ , and  $\lambda$  is a scalar. The values of  $\lambda$  that satisfy the equation are the eigenvalues. The corresponding values of  $v$  that satisfy the equation are the right eigenvectors.

`lambda = eig(A,balanceOption)` specifies a balancing option as one of two strings: 'balance', which enables a preliminary balancing step, or 'nobalance' which disables it.

`lambda = eig(A,B)` returns a vector containing the generalized eigenvalues of the pair,  $(A,B)$ , that satisfy the equation  $Av = \lambda Bv$ , where  $A$  and  $B$  are  $n$ -by- $n$  matrices,  $v$  is a column vector of length  $n$ , and  $\lambda$  is a scalar. The values of  $\lambda$  that satisfy the equation are the generalized eigenvalues. The corresponding values of  $v$  are the generalized right eigenvectors.

`lambda = eig(A,B,algorithm)` specifies the generalized eigenvalue algorithm as one of two strings: 'qz', which uses the QZ algorithm, or 'chol', which uses the Cholesky factorization of  $B$ .

`[V,D] = eig( ___ )` returns two optional outputs for any of the previous input syntaxes. D is a diagonal matrix containing the eigenvalues. V is a matrix whose columns are the corresponding right eigenvectors.

`[V,D,W] = eig( ___ )` also returns W, a matrix whose columns are the corresponding left eigenvectors, using any of the previous input syntaxes. The left eigenvectors,  $w$ , satisfy the equation  $w^\dagger A = \lambda w^\dagger$ .

`[ ___ ] = eig( ___, eigvalOption)` returns the eigenvalues in the form specified by `eigvalOption` using any of the previous syntaxes or outputs. Specify `eigvalOption` as 'vector' to return a column vector of eigenvalues, `lambda`, or as 'matrix' to return a diagonal matrix of eigenvalues, D.

## Input Arguments

### A - Input matrix

square matrix

Input matrix, specified as a real or complex square matrix.

#### Data Types

double | single

**Complex Number Support:** Yes

### B - Generalized eigenvalue problem input matrix

square matrix

Generalized eigenvalue problem input matrix, specified as a square matrix of real or complex values. B must be the same size as A.

#### Data Types

double | single

**Complex Number Support:** Yes

### balanceOption - Balance option

'balance' (default) | 'nobalance'

Balance option, specified as one two strings: 'balance', which enables a preliminary balancing step, or 'nobalance' which disables it. In most

cases, the balancing step improves the conditioning of A to produce more accurate results. However, there are cases in which balancing produces incorrect results. Specify 'nobalance' when A contains values whose scale differs dramatically. For example, if A contains nonzero integers, as well as very small (near zero) values, then the balancing step might scale the small values to make them as significant as the integers and produce inaccurate results.

'balance' is the default behavior. The eig function ignores balanceOption when A is symmetric.

## Data Types

char

## algorithm - Generalized eigenvalue algorithm

'chol' | 'qz'

Generalized eigenvalue algorithm, specified as 'chol' or 'qz', which selects the algorithm to use for calculating the generalized eigenvalues of a pair.

| algorithm | Description                                                                                                               |
|-----------|---------------------------------------------------------------------------------------------------------------------------|
| 'chol'    | Computes the generalized eigenvalues of A and B using the Cholesky factorization of B.                                    |
| 'qz'      | Uses the QZ algorithm, also known as the generalized Schur decomposition. This algorithm ignores the symmetry of A and B. |

In general, the two algorithms return the same result. The QZ algorithm can be more stable for certain problems, such as those involving badly conditioned matrices.

When you omit the algorithm argument, the eig function selects an algorithm based on the properties of A and B. It uses the 'chol'



algorithm for symmetric (Hermitian) A and symmetric (Hermitian) positive definite B. Otherwise, it uses the 'qz' algorithm.

Regardless of the algorithm you specify, the `eig` function always uses the QZ algorithm when A or B are not symmetric.

### **eigvalOption - Eigenvalue option**

'vector' | 'matrix'

Eigenvalue option, specified as 'vector' or 'matrix'. This option allows you to specify whether the eigenvalues are returned in a column vector, `lambda`, or a diagonal matrix, `D`. The default behavior varies according to the number of outputs specified:

- If you specify one output, such as `lambda = eig(A)`, then the eigenvalues are returned as a column vector, `lambda`, by default.
- If you specify two or three outputs, such as `[V,D] = eig(A)`, then the eigenvalues are returned as a diagonal matrix, `D`, by default.

**Example:** `D = eig(A, 'matrix')` returns a diagonal matrix of eigenvalues with the one output syntax.

### **Data Types**

char

## **Output Arguments**

### **lambda - Eigenvalues**

column vector

Eigenvalues, returned as a column vector containing the eigenvalues (or generalized eigenvalues of a pair) with multiplicity.

- When A is real and symmetric or complex Hermitian, the values of `lambda` that satisfy  $Av = \lambda v$  are real.
- When A is real and skew-symmetric or skew-Hermitian, the values of `lambda` that satisfy  $Av = \lambda v$  are purely imaginary or zero.

### **V - Right eigenvectors**

square matrix

Right eigenvectors, returned as a square matrix whose columns are the right eigenvectors of  $A$  or generalized right eigenvectors of the pair,  $(A,B)$ . The form and normalization of  $V$  depends on the combination of input arguments:

- $[V,D] = \text{eig}(A)$  returns matrix  $V$ , whose columns are the right eigenvectors of  $A$  such that  $A*V = V*D$ . The eigenvectors in  $V$  are normalized so that the 2-norm of each is 1.
- $[V,D] = \text{eig}(A, 'nobalance')$  also returns matrix  $V$ . However, the 2-norm of each eigenvector is not necessarily 1.
- $[V,D] = \text{eig}(A,B)$  and  $[V,D] = \text{eig}(A,B, \text{algorithm})$  returns  $V$  as a matrix whose columns are the generalized right eigenvectors that satisfy  $A*V = B*V*D$ . The 2-norm of each eigenvector is not necessarily 1. In this case,  $D$  contains the generalized eigenvalues of the pair,  $(A,B)$ , along the main diagonal.

If  $A$  is symmetric and  $B$  is symmetric positive definite, then the eigenvectors in  $V$  are normalized so that the  $B$ -norm of each is 1.

## **D - Diagonal eigenvalues matrix**

diagonal matrix

Diagonal eigenvalues matrix, returned as a matrix containing the eigenvalues of  $A$  or the generalized eigenvalues of the pair,  $(A,B)$ , with multiplicity.

- When  $A$  is real and symmetric or complex Hermitian, the values of  $D$  that satisfy  $Av = \lambda v$  are real.
- When  $A$  is real and skew-symmetric or skew-Hermitian, the values of  $D$  that satisfy  $Av = \lambda v$  are purely imaginary or zero.

## **W - Left eigenvectors**

square matrix

Left eigenvectors, returned as a square matrix whose columns are the left eigenvectors of  $A$  or generalized left eigenvectors of the pair,  $(A,B)$ . The form and normalization of  $W$  depends on the combination of input arguments:

- $[V,D,W] = \text{eig}(A)$  returns matrix  $W$ , whose columns are the left eigenvectors of  $A$  such that  $W' * A = D * W'$ . The eigenvectors in  $W$  are normalized so that the 2-norm of each is 1. If  $A$  is symmetric, then  $W$  is the same as  $V$ .
- $[V,D,W] = \text{eig}(A, 'nobalance')$  also returns matrix  $W$ . However, the 2-norm of each eigenvector is not necessarily 1.
- $[V,D,W] = \text{eig}(A,B)$  and  $[V,D,W] = \text{eig}(A,B, \text{algorithm})$  returns  $W$  as a matrix whose columns are the generalized left eigenvectors that satisfy  $W' * A = D * W' * B$ . The 2-norm of each eigenvector is not necessarily 1. In this case,  $D$  contains the generalized eigenvalues of the pair,  $(A,B)$ , along the main diagonal.

If  $A$  and  $B$  are symmetric, then  $W$  is the same as  $V$ .

## Examples

### Eigenvalues of Real Symmetric Matrix

Use the gallery function to create symmetric positive definite matrix.

```
A = gallery('lehmer',4)
```

```
A =
```

```

1.0000 0.5000 0.3333 0.2500
0.5000 1.0000 0.6667 0.5000
0.3333 0.6667 1.0000 0.7500
0.2500 0.5000 0.7500 1.0000
```

Calculate the eigenvalues of  $A$ .

```
lambda = eig(A)
```

```
lambda =
```

```

0.2078
0.4078
0.8482
2.5362
```

The result is a column vector.

Alternatively, use `eigvalOption` to return the eigenvalues in a diagonal matrix.

```
D = eig(A, 'matrix')
```

```
D =
```

```
 0.2078 0 0 0
 0 0.4078 0 0
 0 0 0.8482 0
 0 0 0 2.5362
```

## Eigenvalues and Eigenvectors of Nonsymmetric Matrix

Use the `gallery` function to create a circulant matrix.

```
A = gallery('circul',3)
```

```
A =
```

```
 1 2 3
 3 1 2
 2 3 1
```

Calculate the eigenvalues and right eigenvectors of A.

```
[V,D] = eig(A)
```

```
V =
```

```
-0.5774 + 0.0000i 0.2887 - 0.5000i 0.2887 + 0.5000i
-0.5774 + 0.0000i -0.5774 + 0.0000i -0.5774 + 0.0000i
-0.5774 + 0.0000i 0.2887 + 0.5000i 0.2887 - 0.5000i
```

```
D =
```

```

6.0000 + 0.0000i 0.0000 + 0.0000i 0.0000 + 0.0000i
0.0000 + 0.0000i -1.5000 + 0.8660i 0.0000 + 0.0000i
0.0000 + 0.0000i 0.0000 + 0.0000i -1.5000 - 0.8660i

```

Verify that matrix  $V$  diagonalizes  $A$ , since the eigenvalues are distinct and the eigenvectors are independent.

```
V\A*V
```

```
ans =
```

```

6.0000 + 0.0000i 0.0000 - 0.0000i -0.0000 + 0.0000i
-0.0000 - 0.0000i -1.5000 + 0.8660i -0.0000 - 0.0000i
-0.0000 + 0.0000i -0.0000 + 0.0000i -1.5000 - 0.8660i

```

### Eigenvalues and Eigenvectors of a Matrix Whose Elements Differ Dramatically in Scale

```

A = [3.0 -2.0 -0.9 2*eps;
 -2.0 4.0 1.0 -eps;
 -eps/4 eps/2 -1.0 0;
 -0.5 -0.5 0.1 1.0];

```

Calculate the eigenvalues and right eigenvectors using the default (balancing) behavior.

```
[VB,DB] = eig(A)
```

```
VB =
```

```

0.6153 -0.4176 -0.0000 -0.1437
-0.7881 -0.3261 -0.0000 0.1264
-0.0000 -0.0000 -0.0000 -0.9196
0.0189 0.8481 1.0000 0.3432

```

```
DB =
```

```
5.5616 0 0 0
 0 1.4384 0 0
 0 0 1.0000 0
 0 0 0 -1.0000
```

Check to see if the results satisfy  $A*VB = VB*DB$ .

$A*VB - VB*DB$

ans =

```
0.0000 0.0000 -0.0000 0.0000
 0 -0.0000 0.0000 -0.0000
0.0000 -0.0000 0.0000 0.0000
 0 0.0000 0.0000 0.6031
```

This result does not satisfy  $A*VB = VB*DB$ . Ideally, the eigenvalue decomposition satisfies this relationship. Since MATLAB performs the decomposition using floating-point computations, then  $A*V$  can, at best, approach  $V*D$ . In other words,  $A*V - V*D$  is close to, but not exactly, 0.

Now, try calculating the eigenvalues and right eigenvectors without the balancing step.

$[VN, DN] = \text{eig}(A, 'nobalance')$

VN =

```
0.6153 -0.4176 -0.0000 -0.1528
-0.7881 -0.3261 0 0.1345
-0.0000 -0.0000 -0.0000 -0.9781
0.0189 0.8481 -1.0000 0.0443
```

DN =

```
5.5616 0 0 0
```

```

0 1.4384 0 0
0 0 1.0000 0
0 0 0 -1.0000

```

Verify that the results satisfy  $A*VN = VN*DN$ .

$A*VN - VN*DN$

ans =

```

1.0e-14 *
-0.1776 -0.0111 -0.0559 -0.0167
0.3553 0.1055 0.0336 -0.0194
0.0017 0.0002 0.0007 0
0.0264 -0.0222 0.0222 0.0097

```

$A*VN - VN*DN$  is much closer to 0, so the 'nobalance' option produces more accurate results in this case.

### Left Eigenvectors

Create a 3-by-3 matrix.

```
A = [1 7 3; 2 9 12; 5 22 7];
```

Calculate the right eigenvectors, V, the eigenvalues, D, and the left eigenvectors, W.

```
[V,D,W] = eig(A)
```

V =

```

-0.2610 -0.9734 0.1891
-0.5870 0.2281 -0.5816
-0.7663 -0.0198 0.7912

```

D =

```
25.5548 0 0
 0 -0.5789 0
 0 0 -7.9759
```

W =

```
-0.1791 -0.9587 -0.1881
-0.8127 0.0649 -0.7477
-0.5545 0.2768 0.6368
```

Matrix W contains the left eigenvectors.

Verify the results satisfy  $W' * A = D * W'$ .

$W' * A - D * W'$

ans =

```
1.0e-13 *
-0.0444 -0.1066 -0.0888
-0.0011 0.0442 0.0333
 0 0.0266 0.0178
```

Ideally, the eigenvalue decomposition satisfies the relationship. Since MATLAB performs the decomposition using floating-point computations, then  $W' * A$  can, at best, approach  $D * W'$ . In other words,  $W' * A - D * W'$  is close to, but not exactly, 0.

## **Eigenvalues and Eigenvectors of Nondiagonalizable (Defective) Matrix**

Create a 3-by-3 matrix.

```
A = [3 1 0; 0 3 1; 0 0 3];
```

Calculate the eigenvalues and right eigenvectors of A.



```
[V,D] = eig(A)
```

```
V =
```

```
 1.0000 -1.0000 1.0000
 0 0.0000 -0.0000
 0 0 0.0000
```

```
D =
```

```
 3 0 0
 0 3 0
 0 0 3
```

A has repeated eigenvalues and the eigenvectors are not independent. This means that A is not diagonalizable and is, therefore, defective.

Verify that V and D satisfy the equation,  $A*V = V*D$ , even though A is defective.

```
A*V - V*D
```

```
ans =
```

```
 1.0e-15 *
 0 0.8882 -0.8882
 0 0 0.0000
 0 0 0
```

Ideally, the eigenvalue decomposition satisfies the relationship. Since MATLAB performs the decomposition using floating-point computations, then  $A*V$  can, at best, approach  $V*D$ . In other words,  $A*V - V*D$  is close to, but not exactly, 0.

## Generalized Eigenvalues and Eigenvectors

Create two matrices, A and B, then solve the generalized eigenvalue problem for the eigenvalues and right eigenvectors of the pair (A,B).

```
A = [1/sqrt(2) 0; 0 1];
B = [0 1; -1/sqrt(2) 0];
[V,D]=eig(A,B)
```

```
V =
```

```
1.0000 + 0.0000i 1.0000 + 0.0000i
0.0000 - 0.7071i 0.0000 + 0.7071i
```

```
D =
```

```
0.0000 + 1.0000i 0.0000 + 0.0000i
0.0000 + 0.0000i 0.0000 - 1.0000i
```

Verify that the results satisfy  $A*V = B*V*D$ .

```
A*V - B*V*D
```

```
ans =
```

```
0 0
0 0
```

The residual error  $A*V - B*V*D$  is exactly zero.

## Generalized Eigenvalues Using QZ Algorithm for Badly Conditioned Matrices

Create a badly conditioned symmetric matrix containing values close to machine precision.

```
format long e
A = diag([10^-16, 10^-15])
```

```
A =
```

```
1.0000000000000000e-16 0
0 1.0000000000000000e-15
```

Calculate the generalized eigenvalues and a set of right eigenvectors using the default algorithm. In this case, the default algorithm is 'chol'.

```
[V1,D1] = eig(A,A)
```

```
V1 =
```

```
1.0000000000000000e+08 0
 0 3.162277660168380e+07
```

```
D1 =
```

```
9.999999999999999e-01 0
 0 1.0000000000000000e+00
```

Now, calculate the generalized eigenvalues and a set of right eigenvectors using the 'qz' algorithm.

```
[V2,D2] = eig(A,A,'qz')
```

```
V2 =
```

```
1 0
0 1
```

```
D2 =
```

```
1 0
0 1
```

Check to see how well the 'chol' result satisfies  $A*V1 = A*V1*D1$ .

```
format
```

```
A*V1 - A*V1*D1
```

```
ans =

1.0e-23 *

0.1654 0
0 -0.6617
```

Now, check to see how well the 'qz' result satisfies  $A*V2 = A*V2*D2$ .

```
A*V2 - A*V2*D2
```

```
ans =

0 0
0 0
```

When both matrices are Hermitian, `eig` uses the 'chol' algorithm by default. In this case, the QZ algorithm returns more accurate results.

## **Generalized Eigenvalues and Eigenvectors of a Pair in Which One Matrix is Singular**

Create a 2-by-2 identity matrix, A, and a singular matrix, B.

```
A = eye(2);
B = [3 6; 4 8];
```

Try to calculate the generalized eigenvalues of the matrix,  $B^{-1}A$ .

```
[V,D] = eig(B\A)
```

```
Warning: Matrix is singular to working precision.
Error using eig
Input to EIG must not contain NaN or Inf.
```

Now calculate the generalized eigenvalues and right eigenvectors by passing both matrices to the `eig` function.

```
[V,D] = eig(A,B)
```

```
V =
 -0.7500 -1.0000
 -1.0000 0.5000
```

```
D =
 0.0909 0
 0 Inf
```

It's better to pass both matrices separately, and let `eig` choose the best algorithm to solve the problem. In this case, `eig(A,B)` returned a set of eigenvectors and at least one real eigenvalue, even though `B` is not invertible.

Verify  $Av = \lambda Bv$  for the first eigenvalue and the first eigenvector.

```
eigval = D(1,1);
eigvec = V(:,1);
A*eigvec - eigval*B*eigvec
```

```
ans =
 1.0e-15 *
 0.1110
 0.2220
```

Ideally, the eigenvalue decomposition satisfies the relationship. Since the decomposition is performed using floating-point computations, then `A*eigvec` can, at best, approach `eigval*B*eigvec`, as it does in this case.

## Tips

- The `eig` function returns the eigenvalues of a real, symmetric, sparse matrix for the syntax, `lambda = eig(A)`. Use the `eigs` function for all other sparse eigenvalue and eigenvector problems.

# eig

---

## **See Also**

balance | condeig | eigs | hess | qz | schur

**Purpose**

Largest eigenvalues and eigenvectors of matrix

**Syntax**

```
d = eigs(A)
[V,D] = eigs(A)
[V,D,flag] = eigs(A)
eigs(A,B)
eigs(A,k)
eigs(A,B,k)
eigs(A,k,sigma)
eigs(A,B,k,sigma)
eigs(A,K,sigma,opts)
eigs(A,B,k,sigma,opts)
eigs(Afun,n,...)
```

**Description**

`d = eigs(A)` returns a vector of *A*'s six largest magnitude eigenvalues. *A* must be a square matrix. *A* should be large and sparse, though `eigs` will work on full matrices as well. See “Tips” below.

`[V,D] = eigs(A)` returns a diagonal matrix *D* of *A*'s six largest magnitude eigenvalues and a matrix *V* whose columns are the corresponding eigenvectors.

`[V,D,flag] = eigs(A)` also returns a convergence flag. If `flag` is 0 then all the eigenvalues converged; otherwise not all converged.

`eigs(A,B)` solves the generalized eigenvalue problem  $A*V == B*V*D$ . *B* must be the same size as *A*. `eigs(A,[],...)` indicates the standard eigenvalue problem  $A*V == V*D$ .

`eigs(A,k)` and `eigs(A,B,k)` return the *k* largest magnitude eigenvalues.

`eigs(A,k,sigma)` and `eigs(A,B,k,sigma)` return *k* eigenvalues based on *sigma*, which can take any of the following values:

scalar (real or complex, including 0)      The eigenvalues closest to *sigma*. If A is a function, Afun must return  $Y = (A - \textit{sigma} * B) \backslash x$  (i.e.,  $Y = A \backslash x$  when *sigma* = 0).

'lm'      Largest magnitude (default).

'sm'      Smallest magnitude. Same as *sigma* = 0. If A is a function, Afun must return  $Y = A \backslash x$ .

For real symmetric A and symmetric positive-definite B, the following are also options:

'la'      Largest algebraic

'sa'      Smallest algebraic

'be'      Both ends (one more from high end if k is odd)

For nonsymmetric and complex problems, the following are also options:

'lr'      Largest real part

'sr'      Smallest real part

'li'      Largest imaginary part

'si'      Smallest imaginary part

---

**Note** The syntax `eigs(A,k,...)` is not valid when A is scalar. To pass a value for k, you must specify B as the second argument and k as the third (`eigs(A,B,k,...)`). If necessary, you can set B equal to [], the default.

---

`eigs(A,K,sigma,opts)` and `eigs(A,B,k,sigma,opts)` specify an options structure. Default values are shown in brackets ({}).



| Parameter   | Description                                                                                                                                                                                                                                                                     | Values                                         |
|-------------|---------------------------------------------------------------------------------------------------------------------------------------------------------------------------------------------------------------------------------------------------------------------------------|------------------------------------------------|
| opts.issym  | 1 if A or $A\text{-}\sigma*B$ represented by Afun is symmetric, 0 otherwise.                                                                                                                                                                                                    | {0   1}                                        |
| opts.isreal | 1 if A or $A\text{-}\sigma*B$ represented by Afun is real, 0 otherwise.                                                                                                                                                                                                         | {0   {1}}                                      |
| opts.tol    | Convergence: Ritz estimate residual $\leq \text{tol}*\text{norm}(A)$ .                                                                                                                                                                                                          | [scalar   {eps}]                               |
| opts.maxit  | Maximum number of iterations.                                                                                                                                                                                                                                                   | [integer   {300}]                              |
| opts.p      | Number of Lanczos basis vectors.<br>$p \geq 2k$ ( $p \geq 2k+1$ real nonsymmetric) advised. $p$ must satisfy $k < p \leq n$ for real symmetric, $k+1 < p \leq n$ otherwise.<br>Note: If you do not specify a $p$ value, the default algorithm uses at least 20 Lanczos vectors. | [integer   {2*k}]                              |
| opts.v0     | Starting vector.                                                                                                                                                                                                                                                                | [n-by-1 vector   {randomly generated by rand}] |
| opts.disp   | Diagnostic information display level.                                                                                                                                                                                                                                           | {0   1   2}                                    |
| opts.cholB  | 1 if B is really its Cholesky factor $\text{chol}(B)$ , 0 otherwise.                                                                                                                                                                                                            | {0   1}                                        |
| opts.permB  | Permutation vector permB if sparse B is really $\text{chol}(B(\text{permB}, \text{permB}))$ .                                                                                                                                                                                   | [permB   {1:n}]                                |

`eigs(Afun,n,...)` accepts a function handle, `Afun`, instead of the matrix `A`.

`y = Afun(x)` should return:

|                            |                                                                                                                                              |
|----------------------------|----------------------------------------------------------------------------------------------------------------------------------------------|
| <code>A*x</code>           | if <i>sigma</i> is not specified, or is a string other than 'sm'                                                                             |
| <code>A\x</code>           | if <i>sigma</i> is 0 or 'sm'                                                                                                                 |
| <code>(A-sigma*I)\x</code> | if <i>sigma</i> is a nonzero scalar (standard eigenvalue problem). <code>I</code> is an identity matrix of the same size as <code>A</code> . |
| <code>(A-sigma*B)\x</code> | if <i>sigma</i> is a nonzero scalar (generalized eigenvalue problem)                                                                         |

“Parameterizing Functions” explains how to provide additional parameters to the function `Afun`, if necessary.

The matrix `A`, `A-sigma*I` or `A-sigma*B` represented by `Afun` is assumed to be real and nonsymmetric unless specified otherwise by `opts.isreal` and `opts.issym`. In all the `eigs` syntaxes, `eigs(A,...)` can be replaced by `eigs(Afun,n,...)`.

## Tips

`d = eigs(A,k)` is not a substitute for

```
d = eig(full(A))
d = sort(d)
d = d(end-k+1:end)
```

but is most appropriate for large sparse matrices. If the problem fits into memory, it may be quicker to use `eig(full(A))`.

Unless you provide a start vector with `opts.v0`, the default start vector is generated by `rand`, possibly leading to different iterations each run, and perhaps even different convergence behavior. In order to control this, specify your start vector via `opts.v0`.

## Examples

### Smallest Eigenvalues of Sparse Matrix

```
A = delsq(numgrid('C',15));
d1 = eigs(A,5,'sm')
```

returns

```
d1 =
 0.5520
 0.4787
 0.3469
 0.2676
 0.1334
```

### Smallest Eigenvalues of Function-Generated Sparse Matrix

This example replaces the matrix *A* in example 1 with a handle to a function *dnRk*. The example is contained in file *run\_eigs* that

- Calls *eigs* with the function handle *@dnRk* as its first argument.
- Contains *dnRk* as a nested function, so that all variables in *run\_eigs* are available to *dnRk*.

The following shows the code for *run\_eigs*:

```
function d2 = run_eigs
n = 139;
opts.issym = 1;
R = 'C';
k = 15;
d2 = eigs(@dnRk,n,5,'sm',opts);

 function y = dnRk(x)
 y = (delsq(numgrid(R,k))) \ x;
 end
end
```

## Largest Eigenvalue Pairs of Sparse Matrix

west0479 is a real-valued 479-by-479 sparse matrix with both real and complex pairs of conjugate eigenvalues. `eig` computes all 479 eigenvalues. `eigs` easily picks out the largest magnitude eigenvalues.

This plot shows the 8 largest magnitude eigenvalues of west0479 as computed by `eig` and `eigs`.

```
load west0479
d = eig(full(west0479));
d1m = eigs(west0479,8);
[dum,ind] = sort(abs(d));
plot(d1m,'k+'); hold on
plot(d(ind(end-7:end)),'ks'); hold off
legend('eigs(west0479,8)', 'eig(full(west0479))')
```

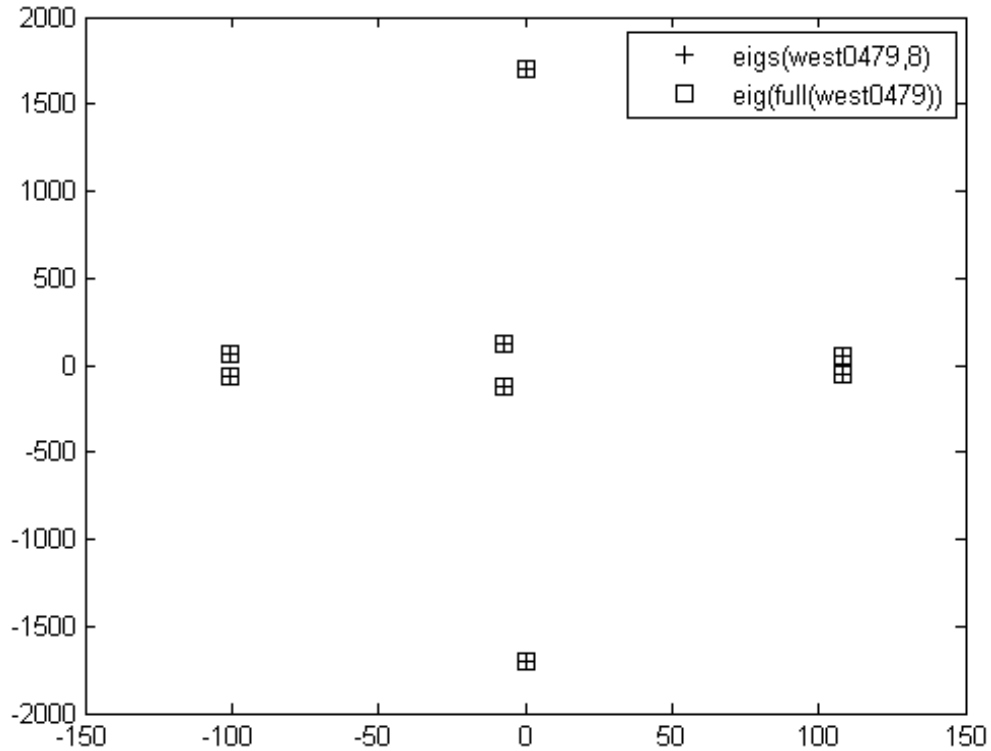

### Repeated Eigenvalues of Symmetric Positive Definite Sparse Matrix

`A = delsq(numgrid('C',30))` is a symmetric positive definite matrix of size 632 with eigenvalues reasonably well-distributed in the interval  $(0, 8)$ , but with 18 eigenvalues repeated at 4.

Use the `eig` function to compute all 632 eigenvalues, and the `eigs` function to compute the six largest and smallest magnitude eigenvalues.

```
A = delsq(numgrid('C',30));
d = sort(eig(full(A)));
d1m = eigs(A);
dsm = eigs(A,6,'sa');
```

Plot the results from `eig` and `eigs` for the six largest and smallest magnitude eigenvalues.

```
subplot(2,1,1)
plot(d1m,'k+'), hold on
plot(d(end:-1:end-5),'ks'), hold off
legend('eigs(A)', 'eig(full(A))',3)
set(gca,'XLim',[0.5 6.5])

subplot(2,1,2)
plot(dsm,'k+'), hold on
plot(d(1:6),'ks'), hold off
legend('eigs(A,6,\'sa\')', 'eig(full(A))',2)
set(gca,'XLim',[0.5 6.5])
```

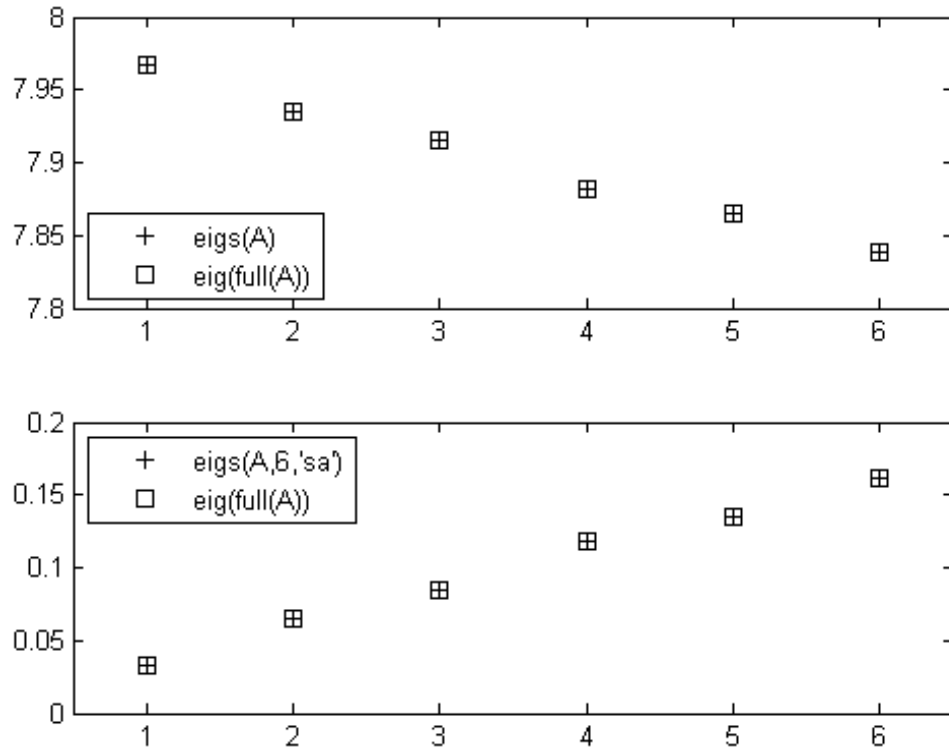

The repeated eigenvalue at 4 must be handled more carefully. The call `eigs(A,20,4.0)` to compute 20 eigenvalues near 4.0 tries to find eigenvalues of  $A - 4.0 \cdot I$ . This involves divisions of the form  $1/(\lambda - 4.0)$ , where  $\lambda$  is an estimate of an eigenvalue of  $A$ . As  $\lambda$  gets closer to 4.0, `eigs` fails. We must use `sigma` near but not equal to 4 to find those eigenvalues.

```
sigma = 4 - 1e-6;
D = sort(eigs(A,20,sigma));
```

# eigs

The plot below shows the 20 eigenvalues closest to 4 that were computed by eig, along with the 20 eigenvalues closest to  $4 - 1e-6$  that were computed by eigs.

```
figure(2);
plot(d(307:326),'ks'), hold on
plot(D,'k+'), hold off
legend('eig(A)', 'eigs(A,20,sigma)')
title('18 Repeated Eigenvalues of A')
```

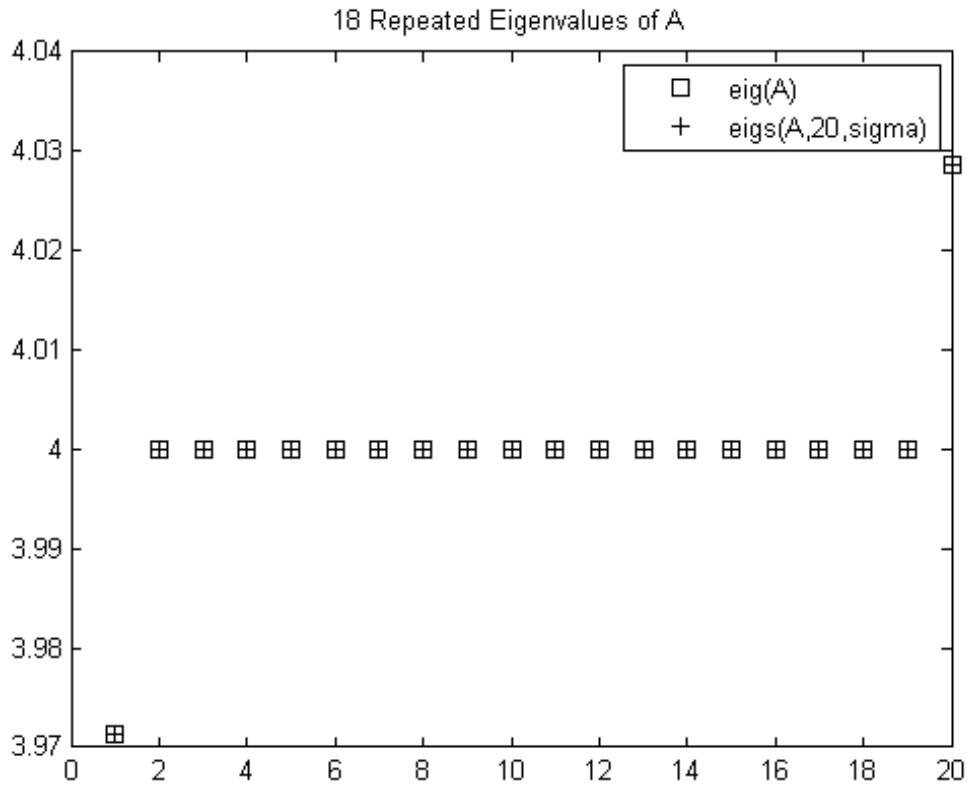



**References**

[1] Lehoucq, R.B. and D.C. Sorensen, “Deflation Techniques for an Implicitly Re-Started Arnoldi Iteration,” *SIAM J. Matrix Analysis and Applications*, Vol. 17, 1996, pp. 789–821.

[2] Sorensen, D.C., “Implicit Application of Polynomial Filters in a k-Step Arnoldi Method,” *SIAM J. Matrix Analysis and Applications*, Vol. 13, 1992, pp. 357–385.

**See Also**

eig | svds | function\_handle

# ellipj

---

**Purpose** Jacobi elliptic functions

**Syntax** [SN,CN,DN] = ellipj(U,M)  
[SN,CN,DN] = ellipj(U,M,tol)

**Definitions** The Jacobi elliptic functions are defined in terms of the integral:

$$u = \int_0^\phi \frac{d\theta}{\sqrt{1 - m \sin^2 \theta}}.$$

Then

$$sn(u) = \sin \phi, \quad cn(u) = \cos \phi, \quad dn(u) = \sqrt{1 - m \sin^2 \phi}.$$

Some definitions of the elliptic functions use the modulus  $k$  instead of the parameter  $m$ . They are related by

$$k^2 = m = \sin^2 \alpha,$$

where  $\alpha$  is the modular angle.

The Jacobi elliptic functions obey many mathematical identities; for a good sample, see [1].

**Description** [SN,CN,DN] = ellipj(U,M) returns the Jacobi elliptic functions SN, CN, and DN, evaluated for corresponding elements of argument U and parameter M. Inputs U and M must be the same size (or either can be scalar).

[SN,CN,DN] = ellipj(U,M,tol) computes the Jacobi elliptic functions to accuracy tol. The default is eps; increase this for a less accurate but more quickly computed answer.

**Algorithms** ellipj computes the Jacobi elliptic functions using the method of the arithmetic-geometric mean of [1]. It starts with the triplet of numbers:

$$a_0 = 1, b_0 = \sqrt{1-m}, c_0 = \sqrt{m}$$

ellipj computes successive iterates with

$$a_i = \frac{1}{2}(a_{i-1} + b_{i-1})$$

$$b_i = (a_{i-1} b_{i-1})^{\frac{1}{2}}$$

$$c_i = \frac{1}{2}(a_{i-1} - b_{i-1})$$

Next, it calculates the amplitudes in radians using:

$$\sin(2\phi_{n-1} - \phi_n) = \frac{c_n}{a_n} \sin(\phi_n)$$

being careful to unwrap the phases correctly. The Jacobian elliptic functions are then simply:

$$sn(u) = \sin \phi_0$$

$$cn(u) = \cos \phi_0$$

$$dn(u) = \sqrt{1 - m \cdot sn(u)^2}$$

## Limitations

The ellipj function is limited to the input domain  $0 \leq m \leq 1$ . Map other values of  $m$  into this range using the transformations described in [1], equations 16.10 and 16.11.  $u$  is limited to real values.

## References

[1] Abramowitz, M. and I.A. Stegun, *Handbook of Mathematical Functions*, Dover Publications, 1965, 17.6.

## See Also

ellipke

# ellipke

---

**Purpose** Complete elliptic integrals of first and second kind

**Syntax**  
`K = ellipke(M)`  
`[K,E] = ellipke(M)`  
`[K,E] = ellipke(M,tol)`

**Description** `K = ellipke(M)` returns the complete elliptic integral of the first kind for the each element in `M`.

`[K,E] = ellipke(M)` returns the complete elliptic integral of the first and second kinds.

`[K,E] = ellipke(M,tol)` computes the complete elliptic integral to accuracy `tol`. The default is `eps(class(M))`; increase the tolerance for a less accurate but more quickly computed answer.

**Limitations** `ellipke` is limited to the input domain  $0 \leq m \leq 1$ .

**Definitions** The *complete* elliptic integral of the first kind is

$$[K(m)] = \int_0^1 [(1-t^2)(1-mt^2)]^{-\frac{1}{2}} dt.$$

where  $m$  is the first argument of `ellipke`.

The complete elliptic integral of the second kind is

$$E(m) = \int_0^1 (1-t^2)^{-\frac{1}{2}} (1-mt^2)^{\frac{1}{2}} dt.$$

Some definitions of `K` and `E` use the elliptical modulus  $k$  or modular angle  $\alpha$  instead of the parameter  $m$ . They are related by

$$k^2 = m = \sin^2 \alpha.$$

**References** [1] Abramowitz, M., and I.A. Stegun. *Handbook of Mathematical Functions*. Dover Publications, 1965.

**See Also**      ellipj

# ellipsoid

---

## Purpose

Generate ellipsoid

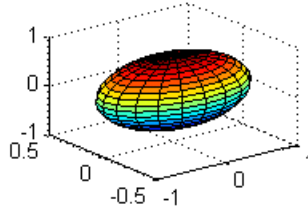

## Syntax

```
[x,y,z] = ellipsoid(xc,yc,zc,xr,yr,zr,n)
[x,y,z] = ellipsoid(xc,yc,zc,xr,yr,zr)
ellipsoid(axes_handle,...)
ellipsoid(...)
```

## Description

`[x,y,z] = ellipsoid(xc,yc,zc,xr,yr,zr,n)` generates a surface mesh described by three  $n+1$ -by- $n+1$  matrices, enabling `surf(x,y,z)` to plot an ellipsoid with center  $(xc,yc,zc)$  and semi-axis lengths  $(xr,yr,zr)$ .

`[x,y,z] = ellipsoid(xc,yc,zc,xr,yr,zr)` uses  $n = 20$ .

`ellipsoid(axes_handle,...)` plots into the axes with handle `axes_handle` instead of the current axes (`gca`).

`ellipsoid(...)` with no output arguments plots the ellipsoid as a surface.

## Algorithms

`ellipsoid` generates the data using the following equation:

$$\frac{(x-xc)^2}{xr^2} + \frac{(y-yc)^2}{yr^2} + \frac{(z-zc)^2}{zr^2} = 1$$

Note that `ellipsoid(0,0,0,.5,.5,.5)` is equivalent to a unit sphere.

**Examples****Surface Plot of Ellipsoid**

Generate data for an ellipsoid with a center at (0,0,0) and semi-axis lengths (5.9,3.25,3.25). Use surf to plot the ellipsoid.

```
[x, y, z] = ellipsoid(0,0,0,5.9,3.25,3.25,30);
figure
surf(x, y, z)
axis equal
```

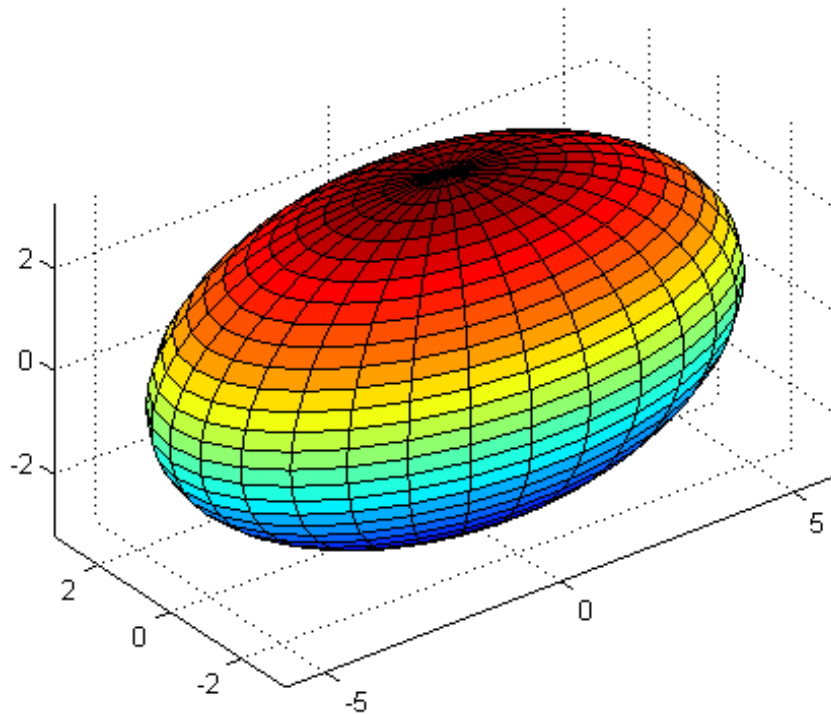

# ellipsoid

---

## **See Also**

cylinder | sphere | surf



---

|                         |                                                                                                                                                                                                                                                                                                                                                                                                                                                                                                                                                                                                                                                                                                                                                                                                                                                                                   |
|-------------------------|-----------------------------------------------------------------------------------------------------------------------------------------------------------------------------------------------------------------------------------------------------------------------------------------------------------------------------------------------------------------------------------------------------------------------------------------------------------------------------------------------------------------------------------------------------------------------------------------------------------------------------------------------------------------------------------------------------------------------------------------------------------------------------------------------------------------------------------------------------------------------------------|
| <b>Purpose</b>          | Create empty array                                                                                                                                                                                                                                                                                                                                                                                                                                                                                                                                                                                                                                                                                                                                                                                                                                                                |
| <b>Syntax</b>           | <pre>A = <i>ClassName</i>.empty A = <i>ClassName</i>.empty(n,m,p,...) A = <i>ClassName</i>.empty([n,m,p,...])</pre>                                                                                                                                                                                                                                                                                                                                                                                                                                                                                                                                                                                                                                                                                                                                                               |
| <b>Description</b>      | <p>Use <code>empty</code> to create empty arrays of the specified class, <i>ClassName</i>. Specify at least one dimension of the array as 0. MATLAB treats negative values as 0.</p> <p><code>A = <i>ClassName</i>.empty</code> returns an empty 0-by-0 array of the class of <i>ClassName</i>.</p> <p><code>A = <i>ClassName</i>.empty(n,m,p,...)</code> returns an empty rectangular array with the specified dimensions. At least one of the dimensions must be 0.</p> <p><code>A = <i>ClassName</i>.empty([n,m,p,...])</code> returns an empty rectangular array with the specified dimensions. At least one of the dimensions must be 0. This syntax is useful when using the values returned by the <code>size</code> function to define an empty array that is the same size as an existing empty array:</p> <pre>A = <i>ClassName</i>.empty(size(otherEmptyArray));</pre> |
| <b>Input Arguments</b>  | <p><b>n,m,p,...</b></p> <p>Dimensions of the empty array. At least one of the specified dimensions must be 0.</p>                                                                                                                                                                                                                                                                                                                                                                                                                                                                                                                                                                                                                                                                                                                                                                 |
| <b>Output Arguments</b> | <p><b>A</b></p> <p>An empty array of the specified dimensions and of the class used in the method invocation.</p>                                                                                                                                                                                                                                                                                                                                                                                                                                                                                                                                                                                                                                                                                                                                                                 |
| <b>Attributes</b>       | <p><code>empty</code> is a hidden, public, static method of all nonabstract MATLAB classes.</p>                                                                                                                                                                                                                                                                                                                                                                                                                                                                                                                                                                                                                                                                                                                                                                                   |

# empty

---

|        |        |
|--------|--------|
| Access | Public |
| Hidden | true   |
| Static | true   |

To learn about attributes of methods, see [Method Attributes in the MATLAB Object-Oriented Programming documentation](#).

## Examples

Use `empty` to create a rectangular empty array of class `int16`:

```
A = int16.empty(5,0);
whos
 Name Size Bytes Class Attributes
 ---- -
 A 5x0 0 int16
```

Using the `empty` method of the `int16` class to produce an empty array in which some dimensions are not zero is simpler than using conversion and reshape operations:

```
A = int16([]);
A = reshape(A,5,0);
whos
 Name Size Bytes Class Attributes
 ---- -
 A 5x0 0 int16
```

Given the following definition for a class,

```
classdef ExEmpty
 properties
 Color = [1,0,0];
 end
 methods
 function obj = ExEmpty(c)
 if nargin > 0
 obj.Color = c;
 end
 end
 end
end
```

```

 end
 end
end

```

Create an empty array of class ExEmpty:

```

A = ExEmpty.empty;
whos
 Name Size Bytes Class Attributes
 ---- -
 A 0x0 104 ExEmpty

```

One dimension of an empty array must be zero:

```

A5 = ExEmpty.empty(0,5);
whos
 Name Size Bytes Class Attributes
 ---- -
 A5 0x5 104 ExEmpty

```

Empty object arrays follow array concatenation behavior:

```

B = [A,A5]
B =

```

0x5 ExEmpty array with properties:

```

 Color

```

You cannot index into an empty array:

```

A5(1)
Index exceeds matrix dimensions.

```

You can use the `isempty`, `size`, and `length` functions to identify empty object arrays:

```

isempty(A5)

```

# empty

---

```
ans =
 1
size(A5)
```

```
ans =
 0 5
length(A5)
```

```
ans =
 0
```

## **Class of Empty Object Array**

The empty method enables you to initialize arrays of a specific class:

```
C = char.empty(0,7)
```

```
C =
```

```
 Empty string: 0-by-7
```

```
class(C)
ans =
```

```
char
```

Initializing an array with empty brackets ([]):

```
a = [];
```

produces an array of class double:

```
class(a)
ans =
```

double

**See Also**

| isempty | size | length

**Tutorials**

- “Creating Empty Arrays”
- “Empty Matrices, Scalars, and Vectors”

# enableNETfromNetworkDrive

---

|                         |                                                                                                                                                                                                                     |
|-------------------------|---------------------------------------------------------------------------------------------------------------------------------------------------------------------------------------------------------------------|
| <b>Purpose</b>          | Enable access to .NET commands from network drive                                                                                                                                                                   |
| <b>Syntax</b>           | <code>enableNETfromNetworkDrive</code>                                                                                                                                                                              |
| <b>Description</b>      | <code>enableNETfromNetworkDrive</code> adds an entry for the MATLAB interface to .NET module to the security policy on your machine. You must have administrative privileges to make changes to your configuration. |
| <b>Compatibility</b>    | Use <code>enableNETfromNetworkDrive</code> for MATLAB releases R2012b or earlier, which support installed versions 2.0, 3.0, and 3.5 of the Microsoft .NET Framework.                                               |
| <b>Related Examples</b> | <ul style="list-style-type: none"><li>• “Troubleshooting Security Policy Settings From Network Drives”</li></ul>                                                                                                    |

**Purpose** Enable, disable, or report status of MATLAB Automation server

**Syntax**

```
state = enableservice('AutomationServer',enable)
state = enableservice('AutomationServer')
```

**Description**

`state = enableservice('AutomationServer',enable)` enables or disables the MATLAB Automation server. If `enable` is true (logical 1), `enableservice` converts an existing MATLAB session into an Automation server. If `enable` is false (logical 0), `enableservice` disables the MATLAB Automation server. `state` indicates the previous state of the Automation server. If `state = 1`, MATLAB was an Automation server. If `state = 0`, MATLAB was not an Automation server.

`state = enableservice('AutomationServer')` returns the current state of the Automation server. If `state` is logical 1 (true), MATLAB is an Automation server.

COM functions are available on Microsoft Windows systems only.

**Examples** Enable the Automation server in the current MATLAB session:

```
state = enableservice('AutomationServer',true);
```

---

Show the current state of the MATLAB session. MATLAB displays true:

```
state = enableservice('AutomationServer')
```

---

Enable the Automation server and show the previous state. MATLAB displays true. The previous state can be the same as the current state:

```
state = enableservice('AutomationServer',true)
```

**See Also** `actxserver`

# enableservice

---

## How To

- “MATLAB COM Automation Server Interface”



**Purpose** Terminate block of code, or indicate last array index

**Syntax** end

**Description** end terminates for, while, switch, try, if, and parfor statements. Without an end statement, for, while, switch, try, if, and parfor wait for further input. Each end is paired with the closest previous unpaired for, while, switch, try, if, or parfor and serves to delimit its scope.

end also marks the termination of a function, although in many cases it is optional. If your function contains one or more nested functions, then you must terminate every function in the file, whether nested or not, with end. This includes primary, nested, private, and local functions.

The end function also serves as the last index in an indexing expression. In that context, end = (size(x,k)) when used as part of the kth index. Examples of this use are X(3:end) and X(1,1:2:end-1). When using end to grow an array, as in X(end+1)=5, make sure X exists first.

You can overload the end statement for a user object by defining an end method for the object. The end method should have the calling sequence end(obj,k,n), where obj is the user object, k is the index in the expression where the end syntax is used, and n is the total number of indices in the expression. For example, consider the expression

```
A(end-1,:)
```

The MATLAB software calls the end method defined for A using the syntax

```
end(A,1,2)
```

**Examples** This example shows end used with the for and if statements.

```
for k = 1:n
 if a(k) == 0
 a(k) = a(k) + 2;
 end
end
```

# end

---

In this example, `end` is used in an indexing expression.

```
A = magic(5)
```

```
A =
```

```
 17 24 1 8 15
 23 5 7 14 16
 4 6 13 20 22
 10 12 19 21 3
 11 18 25 2 9
```

```
B = A(end,2:end)
```

```
B =
```

```
 18 25 2 9
```

## See Also

`parfor` | `while` | `return` | `break` | `for` | `if` | `switch` | `try`

|                         |                                                                                                                                                                                                                                                                                                                                                                            |
|-------------------------|----------------------------------------------------------------------------------------------------------------------------------------------------------------------------------------------------------------------------------------------------------------------------------------------------------------------------------------------------------------------------|
| <b>Purpose</b>          | Retrieve result of asynchronous call initiated by .NET System.Delegate BeginInvoke method                                                                                                                                                                                                                                                                                  |
| <b>Syntax</b>           | <pre>result = EndInvoke(asyncResult) [res0,...,resN] = EndInvoke(res0,...,resN,asyncResult)</pre>                                                                                                                                                                                                                                                                          |
| <b>Description</b>      | <p>result = EndInvoke(asyncResult) retrieves result of asynchronous call initiated by BeginInvoke method.</p> <p>[res0,...,resN] = EndInvoke(res0,...,resN,asyncResult) for methods with out and/or ref parameters.</p>                                                                                                                                                    |
| <b>Tips</b>             | <ul style="list-style-type: none"><li>• If the delegate contains out or ref parameters, the signature for the EndInvoke method follows the MATLAB mapping rules. For information, see “Call Delegates With out and ref Type Arguments”.</li></ul>                                                                                                                          |
| <b>Input Arguments</b>  | <p><b>asyncResult</b><br/>.NET System.IAsyncResult object returned by BeginInvoke.</p> <p><b>res0,...,resN</b><br/>For methods with out and/or ref parameters, results of the asynchronous call. The number of arguments is the sum of:</p> <ul style="list-style-type: none"><li>• Number of return values (0 or 1).</li><li>• Number of out and ref arguments.</li></ul> |
| <b>Output Arguments</b> | <p><b>result</b><br/>Results of the asynchronous call.</p> <p><b>res0,...,resN</b><br/>For methods with out and/or ref parameters, results of the asynchronous call,</p>                                                                                                                                                                                                   |

## Examples

The following examples show how to call delegates with various input and output arguments. Each example contains:

- 1** The C# delegate signature. In order to execute the MATLAB code, build the delegate code into an assembly named `SignatureExamples` and load it into MATLAB. For information, see “Build a .NET Application for MATLAB Examples”.
  - 2** An example MATLAB function to use with the delegate, which must exist on your path.
  - 3** The `BeginInvoke` and `EndInvoke` signatures MATLAB creates. To display the signatures, create a delegate instance, `myDel`, and call the `methodsview` function.
  - 4** Simple MATLAB example.
- 

This example shows how to use a delegate that has no return value.

- 1** C# delegate:

```
public delegate void delint(Int32 arg);
```

- 2** MATLAB function to call:

```
%Display input argument
function dispfnc(A)
%A = number
['Input is ' num2str(A)]
end
```

- 3** MATLAB creates the following signatures. For `BeginInvoke`:

```
System.IAsyncResultRetVal
BeginInvoke (
 SignatureExamples.delint this,
 int32 scalar arg,
```

```
System.AsyncCallback callback,
System.Object object)
```

The EndInvoke signature:

```
EndInvoke (
 SignatureExamples.delint this,
 System.IAsyncResult result)
```

#### 4 Call dispfnc:

```
myDel = SignatureExamples.delint(@dispfnc);
asyncRes = myDel.BeginInvoke(6, [], []);
while asyncRes.IsCompleted ~= true
 pause(0.05); % Use pause() to let MATLAB process event
end
myDel.EndInvoke(asyncRes)
```

Input is 6

---

This example shows how to use a delegate with a return value. The delegate does not have out or ref parameters.

#### 1 C# delegate:

```
public delegate Int32 del2int(Int32 arg1, Int32 arg2);
```

#### 2 MATLAB function to call:

```
%Add input arguments
function res = addfnc(A, B)
%A and B are numbers
res = A + B;
end
```

#### 3 MATLAB creates the following signatures. For BeginInvoke:

# EndInvoke

---

```
System.IAsyncResultRetVal
BeginInvoke (
 SignatureExamples.del2int this,
 int32 scalar arg1,
 int32 scalar arg2,
 System.AsyncCallback callback,
 System.Object object)
```

The EndInvoke signature:

```
int32 scalarRetVal
EndInvoke (
 SignatureExamples.del2int this,
 System.IAsyncResult result)
```

#### 4 Call addfnc:

```
myDel = SignatureExamples.del2int(@addfnc);
asyncRes = myDel.BeginInvoke(6,8,[],[]);
while asyncRes.IsCompleted ~= true
 pause(0.05); % Use pause() to let MATLAB process event
end
result = myDel.EndInvoke(asyncRes)

result =
 14
```

---

This example shows how to use a delegate with a ref parameter, refArg, and no return value.

#### 1 C# delegate:

```
public delegate void delrefvoid(ref Double refArg);
```

#### 2 MATLAB maps the ref argument as both RHS and LHS arguments. MATLAB function to call:

```
%Increment input argument
function res = incfnc(A)
%A = number
res = A + 1;
end
```

**3** MATLAB creates the following signatures. For BeginInvoke:

```
[System.IAsyncResult RetVal,
double scalar refArg]
BeginInvoke (
 SignatureExamples.delrefvoid this,
 double scalar refArg,
 System.AsyncCallback callback,
 System.Object object)
```

The EndInvoke signature:

```
double scalar refArg
EndInvoke (
 SignatureExamples.delrefvoid this,
 double scalar refArg,
 System.IAsyncResult result)
```

**4** Call incfnc:

```
x = 6;
myDel = SignatureExamples.delrefvoid(@incfnc);
asyncRes = myDel.BeginInvoke(x,[],[]);
while asyncRes.IsCompleted ~= true
 pause(0.05); % Use pause() to let MATLAB process event
end
myRef = 0;
result = myDel.EndInvoke(myRef,asyncRes);
disp(['Increment of ' num2str(x) ' = ' num2str(result)]);

Increment of 6 = 7
```

# EndInvoke

---

This example shows how to use a delegate with an out parameter, `argOut`, and one return value.

**1** C# delegate:

```
public delegate Single deloutsingle(Single argIn, out Single argOut);
```

**2** MATLAB maps the out argument as a return value for a total of two return values. MATLAB function to call:

```
%Double input argument
function [res1 res2] = times2fnc(A)
res1 = A*2;
res2 = res1;
end
```

**3** MATLAB creates the following signatures. For `BeginInvoke`:

```
[System.IAsyncResult RetVal,
single scalar argOut]
BeginInvoke (
 SignatureExamples.deloutsingle this,
 single scalar argIn,
 System.AsyncCallback callback,
 System.Object object)
```

The `EndInvoke` signature:

```
[single scalar RetVal,
single scalar argOut]
EndInvoke (
 SignatureExamples.deloutsingle this,
 System.IAsyncResult result)
```

**4** Call `times2fnc`:

```
myDel = SignatureExamples.deloutsingle(@times2fnc);
```



```
asyncRes = myDel.BeginInvoke(6,[],[]);
while asyncRes.IsCompleted ~= true
 pause(0.05); % Use pause() to let MATLAB process event
end
[a1 a2] = myDel.EndInvoke(asyncRes);
a1

a1 =
 12
```

## See Also

[BeginInvoke](#)

## How To

- [“Calling .NET Methods Asynchronously”](#)

## Related Links

- [MSDN Calling Synchronous Methods Asynchronously](#)

# eomday

---

**Purpose** Last day of month

**Syntax** E = eomday(Y, M)

**Description** E = eomday(Y, M) returns the last day of the year and month given by corresponding elements of arrays Y and M.

**Examples** Show the end of month for January through September for the year 1900:

```
eomday(1900, 1:9)
ans =
 31 28 31 30 31 30 31 31 30
```

Find the number of days during that period:

```
sum(eomday(1900, 1:9))
ans =
 273
```

Because 1996 is a leap year, the statement eomday(1996,2) returns 29. To show all the leap years in the twentieth century, try:

```
y = 1900:1999;
E = eomday(y, 2);
y(find(E == 29))

ans =
Columns 1 through 6
 1904 1908 1912 1916 1920 1924

Columns 7 through 12
 1928 1932 1936 1940 1944 1948

Columns 13 through 18
 1952 1956 1960 1964 1968 1972
```

Columns 19 through 24

1976      1980      1984      1988      1992      1996

**See Also**

`datenum` | `datevec` | `weekday`

# enumeration

---

**Purpose** Display class enumeration members and names

**Syntax**

```
enumeration ClassName
enumeration(obj)
m = enumeration(ClassName)
m = enumeration(obj)
[m,s] = enumeration(ClassName)
[m,s] = enumeration(obj)
```

**Description**

`enumeration ClassName` displays the names of the enumeration members for the MATLAB class with the name `ClassName`.

`enumeration(obj)` displays the names of the enumeration members for the class of `obj`.

`m = enumeration(ClassName)` returns the enumeration members for the class in the column vector `m` of objects.

`m = enumeration(obj)` returns the enumeration members for the class of object, `obj`, in the column vector `m` of objects.

`[m,s] = enumeration(ClassName)` returns the names of the enumeration members in the cell array of strings `s`. The names in `s` correspond element-wise to the enumeration members in `m`.

`[m,s] = enumeration(obj)` returns the enumeration members for the class of object, `obj`, in the column vector `m` of objects.

- Tips**
- An enumeration class that derives from a built-in class can specify more than one name for a given enumeration member.
  - When you call the `enumeration` function with no output arguments, MATLAB displays only the first name for each enumeration member (as specified in the class definition). To see all available enumeration members and their names, use the two output arguments (for example, `[m, s] = enumeration(obj);`).

**Input Arguments**

**ClassName**  
The name of the enumeration class, in single quotes.

**obj**

A instance of an enumeration class.

**Output Arguments****m**

Column vector of enumeration members.

**s**

Cell array of strings containing the enumeration names.

**Examples**

All examples use the following enumeration class.

```
classdef Boolean < logical
 enumeration
 No (0)
 Yes (1)
 Off (0)
 On (1)
 end
end
```

---

Display the names of the enumeration members for class Boolean:

```
enumeration Boolean
Enumerations for class Boolean:
```

```
 No
 Yes
```

---

Get the enumeration members for class Boolean in a column vector of objects:

```
members = enumeration('Boolean')
members =
```

# enumeration

---

```
No
Yes
```

---

Get all available enumeration members and their names:

```
[members, names] = enumeration('Boolean')
members =
```

```
No
Yes
No
Yes
```

```
names =
```

```
'No '
'Yes '
'Off '
'On '
```

## See Also

classdef

## Tutorials

- “Working with Enumerations”

**Purpose** Floating-point relative accuracy

**Syntax**

```
eps
d = eps(X)
eps('double')
eps('single')
```

**Description** eps returns the distance from 1.0 to the next largest double-precision number, that is  $\text{eps} = 2^{(-52)}$ .

$d = \text{eps}(X)$  is the positive distance from  $\text{abs}(X)$  to the next larger in magnitude floating point number of the same precision as  $X$ .  $X$  may be either double precision or single precision. For all  $X$ ,

$$\text{eps}(X) = \text{eps}(-X) = \text{eps}(\text{abs}(X))$$

$\text{eps}('double')$  is the same as  $\text{eps}$  or  $\text{eps}(1.0)$ .

$\text{eps}('single')$  is the same as  $\text{eps}(\text{single}(1.0))$  or  $\text{single}(2^{-23})$ .

Except for numbers whose absolute value is smaller than  $\text{realmin}$ , if  $2^E \leq \text{abs}(X) < 2^{(E+1)}$ , then

$$\begin{aligned} \text{eps}(X) &= 2^{(E-23)} \text{ if } \text{isa}(X, 'single') \\ \text{eps}(X) &= 2^{(E-52)} \text{ if } \text{isa}(X, 'double') \end{aligned}$$

For all  $X$  of class double such that  $\text{abs}(X) \leq \text{realmin}$ ,  $\text{eps}(X) = 2^{(-1074)}$ . Similarly, for all  $X$  of class single such that  $\text{abs}(X) \leq \text{realmin}('single')$ ,  $\text{eps}(X) = 2^{(-149)}$ .

Replace expressions of the form:

```
if Y < eps * ABS(X)
```

with

```
if Y < eps(X)
```

**Examples**

```
double precision
eps(1/2) = 2^(-53)
```

```
eps(1) = 2^(-52)
eps(2) = 2^(-51)
eps(realmax) = 2^971
eps(0) = 2^(-1074)

if(abs(x) <= realmin, eps(x) = 2^(-1074)
eps(realmin/2) = 2^(-1074)
eps(realmin/16) = 2^(-1074)
eps(Inf) = NaN
eps(NaN) = NaN

single precision
eps(single(1/2)) = 2^(-24)
eps(single(1)) = 2^(-23)
eps(single(2)) = 2^(-22)
eps(realmax('single')) = 2^104
eps(single(0)) = 2^(-149)
eps(realmin('single')/2) = 2^(-149)
eps(realmin('single')/16) = 2^(-149)
if(abs(x) <= realmin('single'), eps(x) = 2^(-149)
eps(single(Inf)) = single(NaN)
eps(single(NaN)) = single(NaN)
```

## See Also

[realmax](#) | [realmin](#) | [intmax](#)



**Purpose** Determine equality

**Syntax** A == B  
eq(A,B)

**Description** A == B returns a logical array with elements set to logical 1 (true) where arrays A and B are equal; otherwise, it returns logical 0 (false). The test compares both real and imaginary parts of numeric arrays. eq returns logical 0 (false) where A or B have NaN or undefined categorical elements.

eq(A,B) is an alternative way to execute A == B, but is rarely used. It enables operator overloading for classes.

**Input Arguments**

**A - Left array**

numeric array | logical array | character array | categorical array

Left array, specified as a numeric array, logical array, character array, or categorical array. Inputs A and B must be the same size unless one is a scalar. A scalar input expands into an array of the same size as the other input.

If one input is a categorical array, the other input can be a categorical array, a cell array of strings, or a single string. A single string expands into a cell array of strings of the same size as the other input. If both inputs are ordinal categorical arrays, they must have the same sets of categories, including their order. If both inputs are categorical arrays that are not ordinal, they can have different sets of categories. See “Compare Categorical Array Elements” for more details.

**Data Types**

single | double | int8 | int16 | int32 | int64 | uint8 | uint16 | uint32 | uint64 | logical | char

**Complex Number Support:** Yes

**B - Right array**

numeric array | logical array | character array | categorical array

Right array, specified as a numeric array, logical array, character array, or categorical array. Inputs **A** and **B** must be the same size unless one is a scalar. A scalar input expands into an array of the same size as the other input.

If one input is a categorical array, the other input can be a categorical array, a cell array of strings, or a single string. A single string expands into a cell array of strings of the same size as the other input. If both inputs are ordinal categorical arrays, they must have the same sets of categories, including their order. If both inputs are categorical arrays that are not ordinal, they can have different sets of categories. See “Compare Categorical Array Elements” for more details.

### Data Types

single | double | int8 | int16 | int32 | int64 | uint8 |  
uint16 | uint32 | uint64 | logical | char

**Complex Number Support:** Yes

## Examples

### Equality of Two Vectors

Create two vectors containing both real and imaginary numbers.

```
A = [1+i 3 2 4+i];
B = [1 3+i 2 4+i];
```

Compare the two vectors for equality.

```
A == B
```

```
ans =
```

```
0 0 1 1
```

The `eq` function tests both real and imaginary parts for equality, and returns logical 1 (true) only where both parts are equal.

### Find Characters in String

Create a string of characters.

```
M = 'masterpiece';
```

Test the string for the presence of a specific character using ==.

```
M == 'e'
```

```
ans =
```

```
 0 0 0 0 1 0 0 0 1 0 1
```

The value of logical 1 (true) in the vector indicates the presence of the character 'e' in the string.

### Find Values in Categorical Array

Create a categorical array.

```
A = categorical({'heads' 'heads' 'tails'; 'tails' 'heads' 'tails'})
```

```
A =
```

```
 heads heads tails
 tails heads tails
```

The array has two categories: 'heads' and 'tails'.

Find all values in the 'heads' category.

```
A == 'heads'
```

```
ans =
```

```
 1 1 0
 0 1 0
```

A value of logical 1 (true) indicates a value in the category.

Compare the rows of A for equality.

```
A(1,:) == A(2,:)
```

```
ans =
 0 1 1
```

The function returns logical 1 (true) where the rows have equal category values.

## Compare Floating-Point Numbers

Some floating-point numbers cannot be represented exactly in binary form. This leads to small differences in results that the == operator reflects.

Perform a few subtraction operations on a floating-point number and store the result in `C`.

```
C = 0.5-0.4-0.1
```

```
C =
-2.7756e-17
```

Intuitively, `C` should be equal to *exactly* 0. Its small value is due to the nature of floating-point arithmetic.

Compare `C` to zero for equality.

```
C == 0
```

```
ans =
 0
```

The result is logical 0 (false).

Compare floating-point numbers using a tolerance, `tol`, instead of ==.

```
tol = eps;
abs(C-0) < tol
```

```
ans =
```

```
1
```

The two numbers, `C` and `0`, are closer to one another than two consecutive floating-point numbers. They are essentially equal.

**Tips**

- When comparing handle objects, use `==` to test whether objects have the same handle. Use `isequal` to determine if objects with different handles have equal property values.

**See Also**

`ge` | `gt` | `le` | `lt` | `ne`

## eq (MException)

---

**Purpose** Compare scalar MException objects for equality

**Syntax** eObj1 == eObj2

**Description** eObj1 == eObj2 tests scalar MException objects eObj1 and eObj2 for equality, returning logical 1 (true) if the two objects are identical, otherwise returning logical 0 (false).

**See Also** last(MException) | addCause(MException) |  
throwAsCaller(MException) | rethrow(MException) |  
throw(MException) | disp(MException) | getReport(MException)  
| ne(MException) | isequal(MException) | MException | assert  
| error | try, catch

**Purpose** Error function

**Syntax**  $Y = \text{erf}(X)$

**Definitions** The error function  $\text{erf}(X)$  is twice the integral of the Gaussian distribution with 0 mean and variance of 1/2.

$$\text{erf}(x) = \frac{2}{\sqrt{\pi}} \int_0^x e^{-t^2} dt$$

**Description**  $Y = \text{erf}(X)$  returns the value of the error function for each element of real array  $X$ .

**See Also** `erfc` | `erfcinv` | `erfcx` | `erfinv`

# erfc

---

**Purpose** Complementary error function

**Syntax**  $Y = \text{erfc}(X)$

**Definitions** The complementary error function  $\text{erfc}(X)$  is defined as

$$\begin{aligned}\text{erfc}(x) &= \frac{2}{\sqrt{\pi}} \int_x^{\infty} e^{-t^2} dt \\ &= 1 - \text{erf}(x)\end{aligned}$$

**Description**  $Y = \text{erfc}(X)$  computes the value of the complementary error function.

**Tips** The relationship between the complementary error function  $\text{erfc}$  and the standard normal probability distribution returned by the Statistics Toolbox function  $\text{normcdf}$  is

$$\text{normcdf}(x) = \left(\frac{1}{2}\right) \times \text{erfc}\left(\frac{-x}{\sqrt{2}}\right)$$

**See Also** [erf](#) | [erfcinv](#) | [erfcx](#) | [erfinv](#)



**Purpose** Inverse complementary error function

**Syntax** `X = erfcinv(Y)`

**Description** `X = erfcinv(Y)` returns the value of the inverse of the complementary error function for each element of `Y`. Elements of `Y` must be in the interval `[0 2]`. The function `erfcinv` satisfies  $y = \text{erfc}(x)$  for  $2 \geq y \geq 0$  and  $-\infty \geq x \geq \infty$ .

**Tips** The relationship between the inverse complementary error function `erfcinv` and the inverse standard normal probability distribution returned by the Statistics Toolbox function `norminv` is:

$$\text{norminv}(p) = (-\sqrt{2}) \times \text{erfcinv}(2p).$$

**See Also** `erf` | `erfc` | `erfcx` | `erfinv`

# erfcx

---

**Purpose** Scaled complementary error function

**Syntax**  $Y = \text{erfcx}(X)$

**Definitions** The scaled complementary error function  $\text{erfcx}(X)$  is defined as

$$\text{erfcx}(x) = e^{x^2} \text{erfc}(x)$$

For large  $X$ ,  $\text{erfcx}(X)$  is approximately  $\left(\frac{1}{\sqrt{\pi}}\right)\frac{1}{x}$

**Description**  $Y = \text{erfcx}(X)$  computes the value of the scaled complementary error function.

**See Also** `erf` | `erfcinv` | `erfc` | `erfinv`

|                    |                                                                                                                                                                                                                                                                                                                                                    |
|--------------------|----------------------------------------------------------------------------------------------------------------------------------------------------------------------------------------------------------------------------------------------------------------------------------------------------------------------------------------------------|
| <b>Purpose</b>     | Inverse error function                                                                                                                                                                                                                                                                                                                             |
| <b>Syntax</b>      | <code>X = erfinv(Y)</code>                                                                                                                                                                                                                                                                                                                         |
| <b>Description</b> | <code>X = erfinv(Y)</code> returns the value of the inverse error function for each element of <code>Y</code> . Elements of <code>Y</code> should be in the interval <code>[-1 1]</code> or the function will return NaN. The function <code>erfinv</code> satisfies $y = \text{erf}(x)$ for $-1 \leq y \leq 1$ and $-\infty \leq x \leq \infty$ . |
| <b>Examples</b>    | <code>erfinv(1)</code> is Inf<br><code>erfinv(-1)</code> is -Inf.                                                                                                                                                                                                                                                                                  |
| <b>See Also</b>    | <code>erf</code>   <code>erfcinv</code>   <code>erfcx</code>   <code>erfc</code>                                                                                                                                                                                                                                                                   |

# error

---

**Purpose** Display message and abort function

**Syntax** `error('msgIdent', 'msgString', v1, v2, ..., vN)`  
`error('msgString', v1, v2, ...)`  
`error('msgString')`  
`error(msgStruct)`

**Description** `error('msgIdent', 'msgString', v1, v2, ..., vN)` generates an exception if the currently-running function tests for and confirms a faulty or unexpected condition. Depending on how the program has been designed to respond to the error, MATLAB either enters a catch block to handle the error condition, or exits the program.

The *msgIdent* argument is a unique *message identifier* string that MATLAB attaches to the error message when it throws the error. A message identifier has the format `component:mnemonic`. Its purpose is to better identify the source of the error (see Message Identifiers for more information).

The *msgString* argument is a character string that informs the user about the cause of the error and can also suggest how to correct the faulty condition. The *msgString* string can include escape sequences such as `\t` or `\n`, as well as any of the format specifiers supported by the `sprintf` function (such as `%s` or `%d`). Additional arguments *v1*, *v2*, ..., *vN* provide values that correspond to and replace the conversion specifiers.

For example, if *msgString* is “Error on line `%d`, command `%s`”, then *v1* is the line number at which the error was detected, and *v2* is the command that failed. See “Formatting Strings” for more detailed information on using string formatting commands.

All string input arguments must be enclosed in single quotation marks. If *msgString* is an empty string, the error command has no effect.

`error('msgString', v1, v2, ...)` reports an error without including a message identifier in the error report. Although including a message identifier in an error report is recommended, it is not required.

`error('msgString')` is the same as the above syntax, except that the `msgString` string contains no conversion specifiers, no escape sequences, and no substitution value (`v1, v2, ...`) arguments. All characters in `msgString` are interpreted exactly as they appear in the `msgString` argument. MATLAB displays the `\t` in `'C:\testFolder'` for example, as a backslash character followed by the letter `t`, and not as a horizontal tab.

`error(msgStruct)` accepts a scalar error structure input `msgStruct` with at least one of the fields `message`, `identifier`, and `stack`. When the `msgStruct` input includes a `stack` field, the `stack` field of the error will be set according to the contents of the `stack` input. When specifying a `stack` input, use the absolute file name and the entire sequence of functions that nests the function in the stack frame. This is the same as the string returned by `dbstack('-completenames')`. If `msgStruct` is an empty structure, no action is taken and `error` returns without exiting the function.

## Tips

The `error` function captures what information it can about the error that occurred and stores it in a data structure that is an object of the `MException` class. This *error record* contains the error message string, message identifier, the error stack, and optionally an array of other exception objects that are intended to provide information as to the cause of the exception. See “Capture Information About Exceptions” for more information on how to access and use an exception object.

You can access information in the exception object using the `catch` function as documented in the `try, catch` reference page. If your program terminates because of an exception and returns control to the Command Prompt, you can access the exception object using the `MException.last` command.

The `error` function also determines where the error occurred and provides this information in the `stack` field of the `MException` object. This field contains a structure array that has the same format as the output of the `dbstack` function. This stack points to the line where the `error` function was called.

# error

---

The following table shows the MATLAB functions that can be useful for throwing an exception:

| Function      | Description                                                               |
|---------------|---------------------------------------------------------------------------|
| error         | Throw exception with specified error message.                             |
| assert        | Evaluate given expression and throw exception if false.                   |
| throw         | Throw exception based on specified MException object.                     |
| throwAsCaller | Throw exception that appears to have been thrown by the calling function. |
| rethrow       | Reissue previously caught exception.                                      |

## Examples

### Example 1 – Simple Error Message

Write a short function `errtest1` that throws an error when called with an incorrect number of input arguments. Include a message identifier `'myApp:argChk'` and error message:

```
function errtest1(x, y)
if nargin ~= 2
 error('myApp:argChk', 'Wrong number of input arguments')
end
```

Call the function with an incorrect number of inputs. The call to `nargin`, a function that checks the number of inputs, fails and the program calls `error`:

```
errtest1(pi)
```

```
Error using errtest1 (line 3)
Wrong number of input arguments
```

If you run this function from the Command Window, you can use the `MException.last` method to view the exception object:

```

err = MException.last
err =
 MException

 Properties:
 identifier: 'myApp:argChk'
 message: 'Wrong number of input arguments'
 cause: {}
 stack: [1x1 struct]
 Methods

err.stack
ans =
 file: 'c:\work\errtest1.m'
 name: 'errtest1'
 line: 3

```

## Example 2 – Special Characters

MATLAB converts special characters (like `\n` and `%d`) in the error message string only when you specify more than one input argument with `error`. In the single-argument case shown below, `\n` is taken to mean backslash-n. It is not converted to a newline character:

```
error('In this case, the newline \n is not converted.')
```

In this case, the newline `\n` is not converted.

But, when more than one argument is specified, MATLAB does convert special characters. This holds true regardless of whether the additional argument supplies conversion values or is a message identifier:

```
error('ErrorTests:convertTest', ...
 'In this case, the newline \n is converted.')
```

In this case, the newline  
is converted.

## error

---

### See Also

last(MException) | getReport(MException) |  
addCause(MException) | throwAsCaller(MException) |  
rethrow(MException) | throw(MException) | MException | warndlg  
| warning | errordlg | dbstop | assert | try



**Purpose** Plot error bars along curve

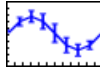

**Syntax**

```
errorbar(Y,E)
errorbar(X,Y,E)
errorbar(X,Y,L,U)
errorbar(...,LineStyle)
h = errorbar(...)
```

**Description** Error bars show the confidence intervals of data or the deviation along a curve.

`errorbar(Y,E)` plots  $Y$  and draws an error bar at each element of  $Y$ . The error bar is a distance of  $E(i)$  above and below the curve so that each bar is symmetric and  $2 \cdot E(i)$  long.

`errorbar(X,Y,E)` plots  $Y$  versus  $X$  with symmetric error bars  $2 \cdot E(i)$  long.  $X$ ,  $Y$ ,  $E$  must be the same size. When they are vectors, each error bar is a distance of  $E(i)$  above and below the point defined by  $(X(i), Y(i))$ . When they are matrices, each error bar is a distance of  $E(i, j)$  above and below the point defined by  $(X(i, j), Y(i, j))$ .

`errorbar(X,Y,L,U)` plots  $X$  versus  $Y$  with error bars  $L(i)+U(i)$  long specifying the lower and upper error bars.  $X$ ,  $Y$ ,  $L$ , and  $U$  must be the same size. When they are vectors, each error bar is a distance of  $L(i)$  below and  $U(i)$  above the point defined by  $(X(i), Y(i))$ . When they are matrices, each error bar is a distance of  $L(i, j)$  below and  $U(i, j)$  above the point defined by  $(X(i, j), Y(i, j))$ .

`errorbar(...,LineStyle)` uses the color and line style specified by the string '`LineStyle`'. The color is applied to the data line and error bars. The linestyle and marker are applied to the data line only. See `linespec` for examples of styles.

`h = errorbar(...)` returns handles to the `errorbarseries` objects created. `errorbar` creates one object for vector input arguments and

# errorbar

---

one object per column for matrix input arguments. See `errorbarseries` properties for more information.

When the arguments are all matrices, `errorbar` draws one line per matrix column. If `X` and `Y` are vectors, they specify one curve.

## Examples

### Symmetric Error Bars

Draw symmetric error bars that are two standard deviation units in length.

```
x = 0:pi/10:pi;
y = sin(x);
e = std(y)*ones(size(x));
```

```
figure
errorbar(x,y,e)
```

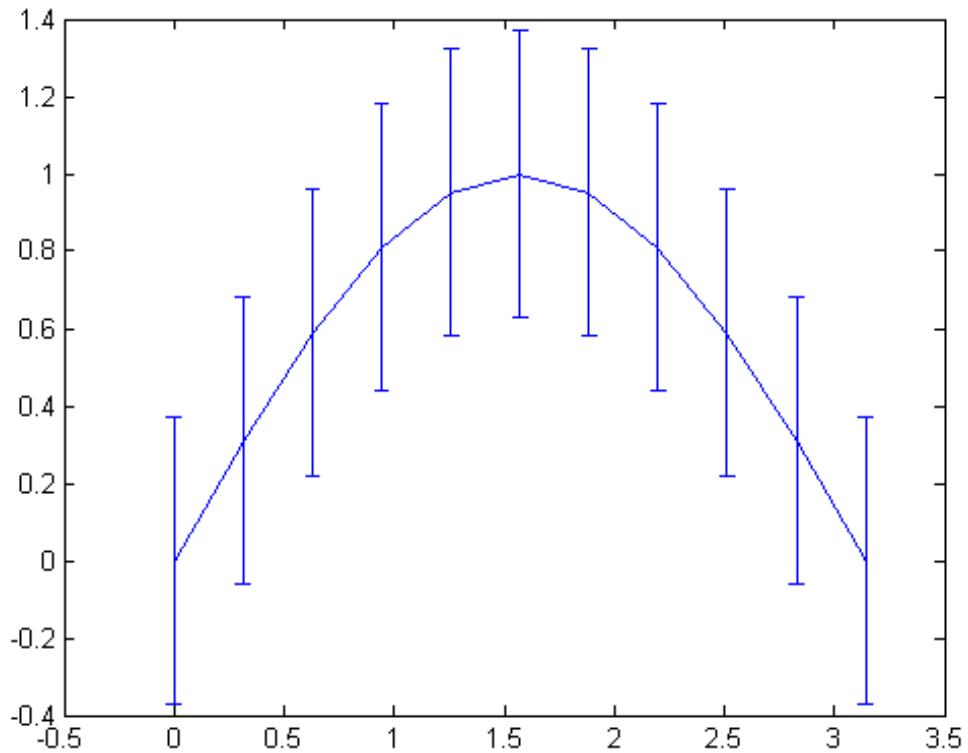

### Change Error Bar Marker and Color

Load the count data set to get the three-column matrix count that contains traffic volume for three street locations over the course of a day. Compute the mean of count for each row.

```
load count.dat;
y = mean(count,2);
```

## errorbar

---

Compute the standard deviation of count for each row and normalize by the number of elements in the sample by setting the second input argument to 1.

```
e = std(count,1,2);
```

Plot the computed average traffic volume,  $y$ , and the computed standard deviations,  $e$ , for the three street locations. Set the `LineStyle` to specify a red color, cross markers, and no line.

```
figure
errorbar(y,e,'rx')
```

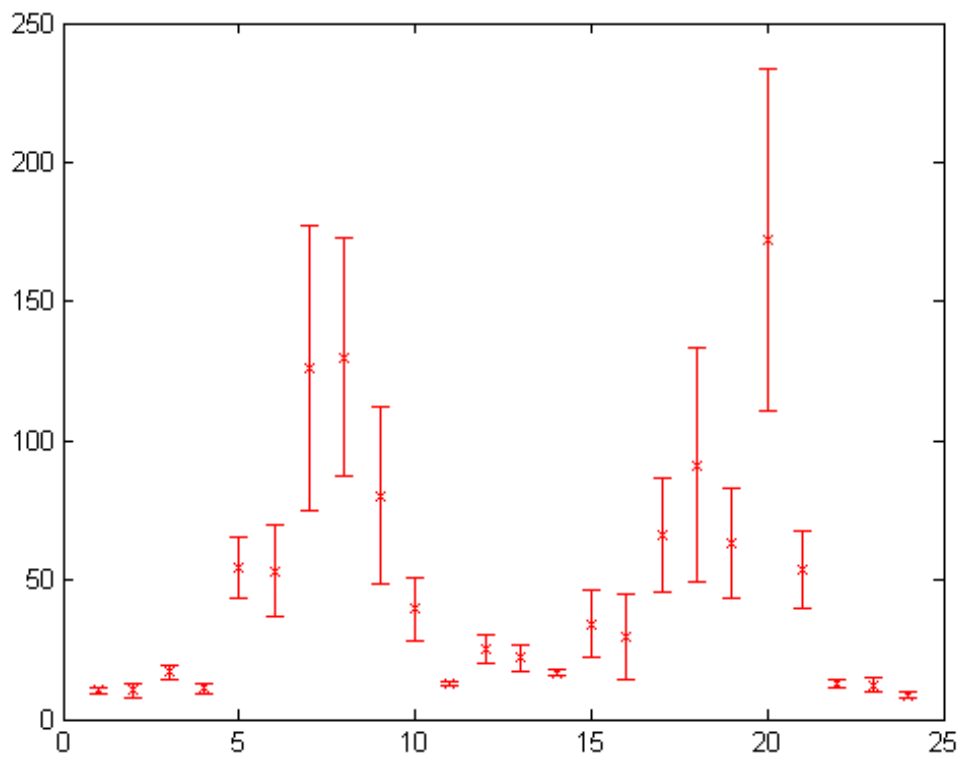
**See Also**

`corrcoef` | `linespec` | `plot` | `std` | `Errorbarseries` Properties

**How To**

- `ConfidenceBounds`

# Errorbarseries Properties

---

## Purpose

Description of errorbarseries properties

## Modifying Properties

You can set and query graphics object properties using the `set` and `get` commands or the Property editor (`propertyeditor`).

Note that you cannot define default property values for errorbarseries objects. See “Plot Objects” for more information on errorbarseries objects.

## Errorbarseries Property Descriptions

This section provides a description of properties. Curly braces { } enclose default values.

Annotation

`hg.Annotation` object (read-only)

*Control the display of errorbarseries objects in legends.* Specifies whether this errorbarseries object is represented in a figure legend.

Querying the Annotation property returns the handle of an `hg.Annotation` object. The `hg.Annotation` object has a property called `LegendInformation`, which contains an `hg.LegendEntry` object.

Once you have obtained the `hg.LegendEntry` object, you can set its `IconDisplayStyle` property to control whether the errorbarseries object is displayed in a figure legend.

| <b>IconDisplayStyle Value</b> | <b>Purpose</b>                                                                           |
|-------------------------------|------------------------------------------------------------------------------------------|
| on                            | Include the errorbarseries object in a legend as one entry, but not its children objects |
| off                           | Do not include the errorbarseries or its children in a legend (default)                  |
| children                      | Include only the children of the errorbarseries as separate entries in the legend        |

## Setting the IconDisplayStyle Property

These commands set the `IconDisplayStyle` of a graphics object with handle `hobj` to `children`, which causes each child object to have an entry in the legend:

```
hAnnotation = get(hobj, 'Annotation');
hLegendEntry = get(hAnnotation, 'LegendInformation');
set(hLegendEntry, 'IconDisplayStyle', 'children')
```

## Using the IconDisplayStyle Property

See “Control Legend Content” for more information and examples.

### BeingDeleted

on | {off} (read-only)

*This object is being deleted.* Mechanism to determine if objects are in the process of being deleted. MATLAB sets the `BeingDeleted` property to `on` when the object’s delete function callback is called (see the `DeleteFcn` property). It remains set to `on` while the delete function executes, after which the object no longer exists.

For example, an object’s delete function calls other functions that act on a number of different objects. If a function does not need to

# Errorbarseries Properties

---

perform an action on an about-be-deleted object, it can check the object's `BeingDeleted` property before acting.

`BusyAction`  
cancel | {queue}

## *Callback queuing*

Determines how MATLAB handles the execution of interrupting callbacks.

A *running* callback is the currently executing callback. The *interrupting* callback is the callback that tries to interrupt the *running* callback. The `BusyAction` property of the *interrupting* callback determines how MATLAB handles its execution. When the `BusyAction` property is set to:

- 'queue' — Puts the *interrupting* callback in a queue to be processed after the *running* callback finishes execution.
- 'cancel' — Discards the *interrupting* callback as MATLAB finishes execution.

For information about how the `Interruptible` property of the callback controls whether other callbacks can interrupt the *running* callback, see the `Interruptible` property description.

`ButtonDownFcn`  
string | function handle

*Button press callback function.* Executes whenever you press a mouse button while the pointer is over this object, but not over another graphics object. See the `HitTestArea` property for information about selecting objects of this type.

See the figure's `SelectionType` property to determine if modifier keys were also pressed.

This property can be:



- A string that is a valid MATLAB expression
- The name of a MATLAB file
- A function handle

Set this property to a function handle that references the callback. The expressions execute in the MATLAB workspace.

For information on the syntax of callback functions, see [Function Handle Callbacks](#).

## Children

array of graphics object handles

*Children of the errorbarseries object.* An array containing the handles of all line objects parented to the errorbarseries object (whether visible or not).

If a child object's `HandleVisibility` property is `callback` or `off`, its handle does not show up in this object's `Children` property. If you want the handle in the `Children` property, set the root `ShowHiddenHandles` property to `on`. For example:

```
set(0, 'ShowHiddenHandles', 'on')
```

## Clipping

{on} | off

*Clipping mode.* MATLAB clips graphs to the axes plot box by default. If you set `Clipping` to `off`, portions of graphs appear outside the axes plot box. This occurs if you create a plot object, set `hold` to `on`, freeze axis scaling (`axis manual`), and then create a larger plot object.

## Color

ColorSpec

# Errorbarseries Properties

---

*Color of the object.* A three-element RGB vector or one of the MATLAB predefined names, specifying the object's color. The default value is [0 0 0] (black).

See the `ColorSpec` reference page for more information on specifying color. See “Adding Arrows and Lines to Graphs”.

`CreateFcn`  
string | function handle

*Not available on errorbarseries objects.*

`DeleteFcn`  
function handle | cell array containing function handle and additional arguments | string (not recommended)

*Callback executed during object deletion.* Executes when this object is deleted (for example, this might happen when you issue a `delete` command on the object, its parent axes, or the figure containing it). MATLAB executes the callback before destroying the object's properties so the callback routine can query these values. The default is an empty array.

The handle of the object whose `DeleteFcn` is being executed is accessible only through the root `CallbackObject` property, which can be queried using `gcbo`.

For information on the syntax of callback functions, see `Function Handle Callbacks`.

See the `BeingDeleted` property for related information.

`DisplayName`  
string

*String used by legend.* The `legend` function uses the `DisplayName` property to label the errorbarseries object in the legend. The default is an empty string.

- If you specify string arguments with the `legend` function, MATLAB set `DisplayName` to the corresponding string and uses that string for the legend.
- If `DisplayName` is empty, `legend` creates a string of the form, `['data' n]`, where `n` is the number assigned to the object based on its location in the list of legend entries. However, `legend` does not set `DisplayName` to this string.
- If you edit the string directly in an existing legend, MATLAB set `DisplayName` to the edited string.
- If you specify a string for the `DisplayName` property and create the legend using the figure toolbar, then MATLAB uses the string defined by `DisplayName`.
- To add a legend programmatically that uses the `DisplayName` string, call `legend` with the `toggle` or `show` option.

See “Control Legend Content” for more information and examples.

### EraseMode

`{normal} | none | xor | background`

*Erase mode.* Controls the technique MATLAB uses to draw and erase objects. Use alternative erase modes for creating animated sequences, where control of the way individual objects are redrawn is necessary to improve performance and obtain the desired effect.

- `normal` — Redraw the affected region of the display, performing the three-dimensional analysis necessary to correctly render all objects. This mode produces the most accurate picture, but is the slowest. The other modes are faster, but do not perform a complete redraw and are therefore less accurate.
- `none` — Do not erase the object when it is moved or destroyed. While the object is still visible on the screen after erasing with `EraseMode none`, you cannot print it because MATLAB stores no information about its former location.

# Errorbarseries Properties

---

- `xor` — Draw and erase the object by performing an exclusive OR (XOR) with the color of the screen beneath it. This mode does not damage the color of the objects beneath it. However, the object's color depends on the color of whatever is beneath it on the display.
- `background` — Erase the object by redrawing it in the axes background `Color`, or the figure background `Color` if the axes `Color` property is `none`. This damages objects that are behind the erased object, but properly colors the erased object.

Set the axes background color with the axes `Color` property. Set the figure background color with the figure `Color` property.

## Printing with Nonnormal Erase Modes

MATLAB always prints figures as if the `EraseMode` of all objects is `normal`. This means graphics objects created with `EraseMode` set to `none`, `xor`, or `background` can look different on screen than on paper. On screen, MATLAB mathematically combines layers of colors (for example, performing an XOR on a pixel color with that of the pixel behind it) and ignore three-dimensional sorting to obtain greater rendering speed. However, these techniques are not applied to the printed output.

You can use the `getframe` command or other screen capture applications to create an image of a figure containing nonnormal mode objects.

`HandleVisibility`  
{on} | callback | off

*Control access to object's handle.* Determines when an object's handle is visible in its parent's list of children. `HandleVisibility` is useful for preventing command-line users from accidentally accessing objects that you need to protect for some reason.

- `on` — Handles are always visible.

- **callback** — Handles are visible from within callback routines or functions invoked by callback routines, but not from within functions invoked from the command line. This provides a means to protect GUIs from command-line users, while allowing callback routines to have access to object handles.
- **off** — Handles are invisible at all times. Use this option when a callback invokes a function that could damage the GUI (such as evaluating a user-typed string). This option temporarily hides its own handles during the execution of that function.

## Functions Affected by Handle Visibility

When a handle is not visible in its parent's list of children, it cannot be returned by functions that obtain handles by searching the object hierarchy or querying handle properties. This includes `get`, `findobj`, `gca`, `gcf`, `gco`, `newplot`, `cla`, `clf`, and `close`.

## Properties Affected by Handle Visibility

When a handle's visibility is restricted using `callback` or `off`, the object's handle does not appear in its parent's `Children` property, figures do not appear in the root's `CurrentFigure` property, objects do not appear in the root's `CallbackObject` property or in the figure's `CurrentObject` property, and axes do not appear in their parent's `CurrentAxes` property.

## Overriding Handle Visibility

You can set the root `ShowHiddenHandles` property to `on` to make all handles visible regardless of their `HandleVisibility` settings. This does not affect the values of the `HandleVisibility` properties. See also `findall`.

## Handle Validity

# Errorbarseries Properties

---

Hidden handles are still valid. If you know an object's handle, you can `set` and `get` its properties and pass it to any function that operates on handles.

---

**Note** If you change one data source property to a variable that contains data of a different dimension, you might cause the function to generate a warning and not render the graph until you have changed all data source properties to appropriate values.

---

## HitTest

{on} | off

*Selectable by mouse click.* Determines whether this object can become the current object (as returned by the `gco` command and the figure `CurrentObject` property) as a result of a mouse click on the curve or error bars that compose the graph. If `HitTest` is off, clicking this object selects the object below it (which is usually the axes containing it).

## HitTestArea

on | {off}

*Select the object by clicking lines or area of extent.* Select plot objects by:

- Clicking curve or error bars (default).
- Clicking anywhere in the extent of the plot.

When `HitTestArea` is off, you must click the curve or error bars to select the object. When `HitTestArea` is on, you can select this object by clicking anywhere within the extent of the plot (that is, anywhere within a rectangle that encloses all the lines).

## Interruptible

off | {on}

## *Callback routine interruption*

Controls whether MATLAB can interrupt an object's callback function when subsequent callbacks attempt to interrupt it.

For Graphics objects, the `Interruptible` property affects only the callbacks for the `ButtonDownFcn` property. A *running* callback is the currently executing callback. The *interrupting* callback is the callback that tries to interrupt the *running* callback. MATLAB handles both the callbacks based on the `Interruptible` property of the object of the *running* callback.

When the `Interruptible` property is set to:

- 'off', MATLAB finishes execution of the *running* callback without any interruptions
- 'on', these conditions apply:
  - If there is a `drawnow`, `figure`, `getframe`, `waitfor`, or `pause` command in the *running* callback, then MATLAB executes the *interrupting* callbacks which are already in the queue and returns to finish execution of the current callback.
  - If one of the above functions is not in the *running* callback, then MATLAB finishes execution of the current callback without any interruption.

`BusyAction` property of the object of interrupting callback determines whether the callback should be ignored or should be put in the queue.

Setting `Interruptible` property to on (default), allows a callback from other graphics objects to interrupt callback functions originating from this object.

# Errorbarseries Properties

---

---

**Note** MATLAB does not save the state of properties or the display when an interruption occurs. For example, the handle returned by the `gca` or `gcf` command may be changed as another callback is executed.

---

After the function that interrupts a callback completes, the callback resumes execution where it halted when interrupted. For more information, see “Control Callback Execution and Interruption”.

## LData

array equal in size to XData and YData

*Errorbar length below data point.* The `errorbar` function uses this data to determine the length of the errorbar below each data point. Specify these values in data units. See also UData.

## LDataSource

string (MATLAB variable)

*Link LData to MATLAB variable.* Set this property to a MATLAB variable that is evaluated in the base workspace to generate the LData.

MATLAB reevaluates this property only when you set it. Therefore, a change to workspace variables appearing in an expression does not change LData.

You can use the `refreshdata` function to force an update of the object’s data. `refreshdata` also enables you to specify that the data source variable be evaluated in the workspace of a function from which you call `refreshdata`. See the `refreshdata` reference page for more information.

## LineStyle

{-} | -- | : | -. | none



*Line style of errorbarseries object.*

## Line Style Specifiers Table

| Specifier | Line Style           |
|-----------|----------------------|
| '-'       | Solid line (default) |
| '--'      | Dashed line          |
| ':'       | Dotted line          |
| '-.'      | Dash-dot line        |
| 'none'    | No line              |

Use `LineStyle none` when you want to place a marker at each point but do not want the points connected with a line (see the `Marker` property).

### LineWidth

size in points

*Width of linear objects and edges of filled areas. Specify in points. 1 point =  $1/72$  inch. The default is 0.5 points.*

### Marker

character (see table)

*Marker symbol.* Specifies marks that display at data points. You can set values for the `Marker` property independently from the `LineStyle` property. For a list of supported marker symbols, see the following table.

## Marker Specifiers Table

| Specifier | Marker Type |
|-----------|-------------|
| '+'       | Plus sign   |
| 'o'       | Circle      |

# Errorbarseries Properties

---

| Specifier            | Marker Type                   |
|----------------------|-------------------------------|
| '*'                  | Asterisk                      |
| '.'                  | Point                         |
| 'x'                  | Cross                         |
| 'square' or 's'      | Square                        |
| 'diamond' or 'd'     | Diamond                       |
| '^'                  | Upward-pointing triangle      |
| 'v'                  | Downward-pointing triangle    |
| '>'                  | Right-pointing triangle       |
| '<'                  | Left-pointing triangle        |
| 'pentagram' or 'p'   | Five-pointed star (pentagram) |
| 'hexagram' or 'h' '' | Six-pointed star (hexagram)   |
| 'none'               | No marker (default)           |

## MarkerEdgeColor

ColorSpec | none | {auto}

*Marker edge color.* The color of the marker or the edge color for filled markers (circle, square, diamond, pentagram, hexagram, and the four triangles).

- ColorSpec — User-defined color.
- none — Specifies no color, which makes nonfilled markers invisible.
- auto — Uses same color as the Color property.

## MarkerFaceColor

ColorSpec | {none} | auto

*Fill color for closed-shape markers.* The fill color for markers that are closed shapes (circle, square, diamond, pentagram, hexagram, and the four triangles).

- `ColorSpec` — User-defined color.
- `none` — Makes the interior of the marker transparent, allowing the background to show through.
- `auto` — Sets the fill color to the axes `Color` property. If the axes `Color` property is `none`, sets the fill color to the figure `Color`.

`MarkerSize`  
scalar

*Marker size.* Size of the marker in points. The default value is 6.

---

**Note** MATLAB draws the point marker (specified by the `'.'` symbol) at one-third the specified size.

---

`Parent`  
handle of parent axes, `hgroup`, or `hgtransform`

*Parent of object.* Handle of the object's parent. The parent is normally the axes, `hgroup`, or `hgtransform` object that contains the object.

`Selected`  
`on` | `{off}`

*Object selection state.* When you set this property to `on`, MATLAB displays selection handles at the corners and midpoints if the `SelectionHighlight` property is also `on` (the default). You can, for example, define the `ButtonDownFcn` callback to set this property to `on`, thereby indicating that this particular object is selected. This property is also set to `on` when an object is manually selected in plot edit mode.

# Errorbarseries Properties

---

SelectionHighlight  
{on} | off

*Objects are highlighted when selected.* When the Selected property is on, MATLAB indicates the selected state by drawing selection handles on the curve and error bars. When SelectionHighlight is off, MATLAB does not draw the handles.

Tag  
string

*User-specified object label.* Provides a means to identify graphics objects with a user-specified label. The default is an empty string.

Use the Tag property and the findobj function to manipulate specific objects within a plotting hierarchy.

For example, create an errorbarseries object and set the Tag property:

```
t = errorbar(Y,E,'Tag','errorbar1')
```

To access the errorbarseries object, use findobj to find the errorbarseries object's handle.

The following statement changes the MarkerFaceColor property of the object whose Tag is errorbar1.

```
set(findobj('Tag','errorbar1'),'MarkerFaceColor','red')
```

Type  
string (read-only)

*Type of graphics object.* String that identifies the class of the graphics object. Use this property to find all objects of a given type within a plotting hierarchy. For errorbarseries objects, Type is 'hgggroup'. The following statement finds all the hgggroup objects in the current axes.

```
t = findobj(gca, 'Type', 'hggroup');
```

## UData

array equal in size to XData and YData

*Errorbar length above data point.* The errorbar function uses this data to determine the length of the errorbar above each data point. Specify these values in data units.

## UDataSource

MATLAB variable, as a string

*Link UData to MATLAB variable.* Set this property to a MATLAB variable that is evaluated in the base workspace to generate the UData. The default value is an empty array.

```
set(h, 'UDataSource', 'Udatavariablename')
```

MATLAB requires a call to `refreshdata` when you set this property. Changing workspace variables used as an object's UDataSource does not change the object's UData values, but you can use `refreshdata` to force an update of the object's data. `refreshdata` also lets you specify that the data source variable be evaluated in the workspace of a function from which you call `refreshdata`.

## UIContextMenu

handle of uicontextmenu object

*Associate a context menu with the errorbarseries object.* Assign this property the handle of a uicontextmenu object created in the errorbarseries object's parent figure. Use the `uicontextmenu` function to create the context menu. MATLAB displays the context menu whenever you right-click over the errorbarseries object.

## UserData

array

# Errorbarseries Properties

---

*User-specified data.* Data you want to associate with the errorbarseries object (including cell arrays and structures). The default value is an empty array. MATLAB does not use this data, but you can access it using the `set` and `get` commands.

## Visible

{on} | off

*Visibility of errorbarseries object and its children.* By default, errorbarseries object visibility is on. This means all children of the errorbarseries object are visible unless the child object's Visible property is off. Setting an errorbarseries object's Visible property to off also makes its children invisible.

## XData

array

*X-coordinates of the curve.* The `errorbar` function plots a curve using the *x*-axis coordinates in the XData array. XData must be the same size as YData.

If you do not specify XData (which is the input argument *X*), the `errorbar` function uses the indices of YData to create the curve. See the XDataMode property for related information.

## XDataMode

{auto} | manual

*Use automatic or user-specified x-axis values.* If you specify XData (by setting the XData property or specifying the input argument *x*), the `errorbar` function sets this property to manual.

If you set XDataMode to auto after having specified XData, the `errorbar` function resets the *x* tick-mark labels to the indices of the YData.

## XDataSource

string (MATLAB variable)

*Link XData to MATLAB variable.* Set this property to a MATLAB variable that is evaluated in the base workspace to generate the XData.

MATLAB reevaluates this property only when you set it. Therefore, a change to workspace variables appearing in an expression does not change XData.

You can use the `refreshdata` function to force an update of the object's data. `refreshdata` also enables you to specify that the data source variable be evaluated in the workspace of a function from which you call `refreshdata`. See the `refreshdata` reference page for more information.

---

**Note** If you change one data source property to a variable that contains data of a different dimension, you might cause the function to generate a warning and not render the graph until you have changed all data source properties to appropriate values.

---

## YData

scalar | vector | matrix

*Data defining curve.* YData contains the data defining the curve. If YData is a matrix, the `errorbar` function displays a curve with error bars for each column in the matrix.

The input argument Y in the `errorbar` function calling syntax assigns values to YData.

## YDataSource

string (MATLAB variable)

*Link YData to MATLAB variable.* Set this property to a MATLAB variable that is evaluated in the base workspace to generate the YData.

# Errorbarseries Properties

---

MATLAB reevaluates this property only when you set it. Therefore, a change to workspace variables appearing in an expression does not change YData.

You can use the `refreshdata` function to force an update of the object's data. `refreshdata` also enables you to specify that the data source variable be evaluated in the workspace of a function from which you call `refreshdata`. See the `refreshdata` reference page for more information.

---

**Note** If you change one data source property to a variable that contains data of a different dimension, you might cause the function to generate a warning and not render the graph until you have changed all data source properties to appropriate values.

---



**Purpose** Create and open error dialog box

**Syntax**

```
h = errordlg
h = errordlg(errorstring)
h = errordlg(errorstring,dlgname)
h = errordlg(errorstring,dlgname,createmode)
```

**Description** `h = errordlg` creates and displays a dialog box with title Error Dialog that contains the string This is the default error string. The `errordlg` function returns the handle of the dialog box in `h`.

`h = errordlg(errorstring)` displays a dialog box with title Error Dialog that contains the string `errorstring`.

`h = errordlg(errorstring,dlgname)` displays a dialog box with titled `dlgname` that contains the string `errorstring`.

`h = errordlg(errorstring,dlgname,createmode)` specifies whether the error dialog box is modal or nonmodal. Optionally, it can also specify an interpreter for `errorstring` and `dlgname`. The `createmode` argument can be a string or a structure.

If `createmode` is a string, it must be one of the values shown in the following table.

| createmode Value    | Description                                                                                                                                                                                                                                                                              |
|---------------------|------------------------------------------------------------------------------------------------------------------------------------------------------------------------------------------------------------------------------------------------------------------------------------------|
| modal               | Replaces the error dialog box having the specified <code>Title</code> , that was last created or clicked on, with a modal error dialog box as specified. All other error dialog boxes with the same title are deleted. The dialog box which is replaced can be either modal or nonmodal. |
| non-modal (default) | Creates a new nonmodal error dialog box with the specified parameters. Existing                                                                                                                                                                                                          |

# errordlg

---

| createmode Value | Description                                                                                                                                                                                                                                                                   |
|------------------|-------------------------------------------------------------------------------------------------------------------------------------------------------------------------------------------------------------------------------------------------------------------------------|
|                  | error dialog boxes with the same title are not deleted.                                                                                                                                                                                                                       |
| replace          | Replaces the error dialog box having the specified Title, that was last created or clicked on, with a nonmodal error dialog box as specified. All other error dialog boxes with the same title are deleted. The dialog box which is replaced can be either modal or nonmodal. |

---

**Note** A modal dialog box prevents the user from interacting with other windows before responding. To block MATLAB program execution as well, use the `uiwait` function.

If you open a dialog with `errordlg`, `msgbox`, or `warndlg` using 'CreateMode', 'modal' and a non-modal dialog created with any of these functions is already present and *has the same name as the modal dialog*, the non-modal dialog closes when the modal one opens.

For more information about modal dialog boxes, see `WindowStyle` in the `Figure Properties`.

---

If `CreateMode` is a structure, it can have fields `WindowStyle` and `Interpreter`. `WindowStyle` must be one of the options shown in the table above. `Interpreter` is one of the strings 'tex' or 'none'. The default value for `Interpreter` is 'none'.

## Tips

MATLAB sizes the dialog box to fit the string 'errorstring'. The error dialog box has an **OK** push button and remains on the screen until you press the **OK** button or the **Return** key. After pressing the button, the error dialog box disappears.

The appearance of the dialog box depends on the platform you use.

**Examples**

This code,

```
errordlg('File not found','File Error');
```

displays this dialog box:

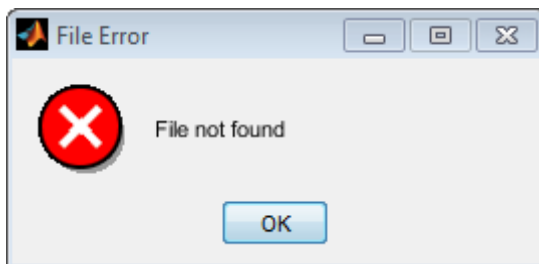

This code,

```
mode = struct('WindowStyle','non-modal',...
 'Interpreter','tex');
h = errordlg('Try this equation instead: f(x) = x^2',...
 'Equation Error', mode);
```

displays this dialog box:

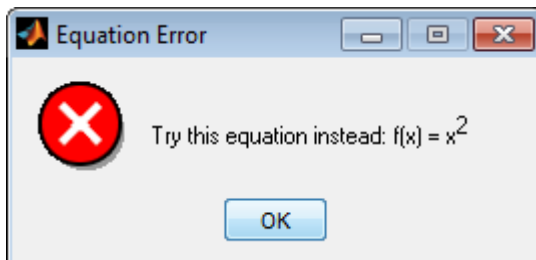
**See Also**

[dialog](#) | [helpdlg](#) | [inputdlg](#) | [listdlg](#) | [msgbox](#) | [questdlg](#) | [warndlg](#) | [figure](#) | [uiwait](#) | [uiresume](#)

# etime

---

**Purpose** Time elapsed between date vectors

**Syntax** `e = etime(t2,t1)`

**Description** `e = etime(t2,t1)` returns the number of seconds between two date vectors or matrices of date vectors, `t1` and `t2`.

**Input Arguments** **t2,t1 - Date vectors**  
1-by-6 vector | m-by-6 matrix

Date vectors, specified as 1-by-6 vectors or m-by-6 matrices containing `m` full date vectors in the format:[Year Month Day Hour Minute Second].

**Example:** [2012 03 27 11 50 01]

**Data Types**  
double

**Examples** **Compute Elapsed Time**

Compute the time elapsed between a specific time and the current time, to 0.01-second accuracy.

Define the initial date and time and convert to date vector form.

```
format shortg
str = 'March 28, 2012 11:51:00';
t1 = datevec(str,'mmm dd, yyyy HH:MM:SS')
```

```
t1 =
```

```
 2012 3 28 11 51 0
```

Determine the current date and time.

```
t2 = clock
```

```
t2 =
 2014 1 17 16 0
```

The `clock` function returns the current date and time as a date vector. Use `etime` to compute the number of seconds between `t1` and `t2`.

```
e = etime(t2,t1)
```

```
e =
 5.7039e+07
```

## Tips

- To time the duration of an event, use the `timeit` or `tic` and `toc` functions instead of `clock` and `etime`. The `clock` function is based on the system time, which can be adjusted periodically by the operating system, and thus might not be reliable in time comparison operations.

## Algorithms

`etime` does not account for the following:

- Leap seconds.
- Daylight savings time adjustments.
- Differences in time zones.

## See Also

`tic` | `toc` | `cputime` | `clock` | `now` | `timeit`

# etree

---

**Purpose** Elimination tree

**Syntax**  
`p = etree(A)`  
`p = etree(A, 'col')`  
`p = etree(A, 'sym')`  
`[p,q] = etree(...)`

**Description** `p = etree(A)` returns an elimination tree for the square symmetric matrix whose upper triangle is that of `A`. `p(j)` is the parent of column `j` in the tree, or 0 if `j` is a root.

`p = etree(A, 'col')` returns the elimination tree of  $A^*A$ .

`p = etree(A, 'sym')` is the same as `p = etree(A)`.

`[p,q] = etree(...)` also returns a postorder permutation `q` of the tree.

**See Also** `treelayout` | `treeplot` | `etreeplot`

|                    |                                                                                                                                                                                                                                                                                                                       |
|--------------------|-----------------------------------------------------------------------------------------------------------------------------------------------------------------------------------------------------------------------------------------------------------------------------------------------------------------------|
| <b>Purpose</b>     | Plot elimination tree                                                                                                                                                                                                                                                                                                 |
| <b>Syntax</b>      | <code>etreeplot(A)</code><br><code>etreeplot(A,nodeSpec,edgeSpec)</code>                                                                                                                                                                                                                                              |
| <b>Description</b> | <code>etreeplot(A)</code> plots the elimination tree of $A$ (or $A+A'$ , if non-symmetric).<br><code>etreeplot(A,nodeSpec,edgeSpec)</code> allows optional parameters <code>nodeSpec</code> and <code>edgeSpec</code> to set the node or edge color, marker, and linestyle. Use <code>' '</code> to omit one or both. |
| <b>See Also</b>    | <code>etree</code>   <code>treepplot</code>   <code>treelayout</code>                                                                                                                                                                                                                                                 |

# eval

---

**Purpose** Execute MATLAB expression in text string

**Syntax**  
`eval(expression)`  
`[output1,...,outputN] = eval(expression)`

**Description** `eval(expression)` evaluates the MATLAB code in the string `expression`. If you use `eval` within an anonymous function, nested function, or function that contains a nested function, the evaluated expression cannot create a variable.

`[output1,...,outputN] = eval(expression)` stores output from `expression` in the specified variables.

- Tips**
- Many common uses of the `eval` function are less efficient and are more difficult to read and debug than other MATLAB functions and language constructs. For more information, see “Alternatives to the `eval` Function”.
  - Whenever possible, do not include output arguments within the input to the `eval` function, such as `eval(['output = ',expression])`. The preferred syntax,

```
output = eval(expression)
```

allows the MATLAB parser to perform stricter checks on your code, preventing untrapped errors and other unexpected behavior.

**Input Arguments** **expression**  
String that contains a valid MATLAB expression.  
To include a numeric value in the expression, convert it to a string with `int2str`, `num2str`, or `sprintf`.

**Output Arguments** **output1,...,outputN**  
Outputs from the evaluated expression.



## Examples

### Variable Name Evaluation

Select a matrix to plot at runtime.

This example requires that you have a matrix in the current workspace. For example:

```
aMatrix = magic(5);
```

Interactively request the name of a matrix to plot, and call `eval` to use its value.

```
expression = input('Enter the name of a matrix: ','s');
if (exist(expression,'var'))
 mesh(eval(expression))
end
```

If you type `aMatrix` at the input prompt, this code creates a mesh plot of `magic(5)`.

## See Also

`evalin` | `feval` | `evalc` | `assignin` | `try`

## Concepts

- “Alternatives to the `eval` Function”
- “Variables in Nested and Anonymous Functions”

# evalc

---

|                         |                                                                                                                                                                                                                                                                                                                                                                                                                                                                                                                                 |
|-------------------------|---------------------------------------------------------------------------------------------------------------------------------------------------------------------------------------------------------------------------------------------------------------------------------------------------------------------------------------------------------------------------------------------------------------------------------------------------------------------------------------------------------------------------------|
| <b>Purpose</b>          | Evaluate MATLAB expression with capture                                                                                                                                                                                                                                                                                                                                                                                                                                                                                         |
| <b>Syntax</b>           | <code>T = evalc(expression)</code><br><code>[T,output1,...,outputN] = evalc(expression)</code>                                                                                                                                                                                                                                                                                                                                                                                                                                  |
| <b>Description</b>      | <p><code>T = evalc(expression)</code> is the same as <code>eval(expression)</code> except that anything that would normally be written to the command window, except for error messages, is captured and returned in the character array <code>T</code> (lines in <code>T</code> are separated by <code>\n</code> characters).</p> <p><code>[T,output1,...,outputN] = evalc(expression)</code> is the same as <code>[output1,...,outputN] = eval(expression)</code> except that any output is captured into <code>T</code>.</p> |
| <b>Tips</b>             | When you are using <code>evalc</code> , functions <code>diary</code> , <code>more</code> , and <code>input</code> are disabled.                                                                                                                                                                                                                                                                                                                                                                                                 |
| <b>Input Arguments</b>  | <p><b>expression</b></p> <p>String that contains a valid MATLAB expression.</p> <p>To include a numeric value in the expression, convert it to a string with <code>int2str</code>, <code>num2str</code>, or <code>sprintf</code>.</p>                                                                                                                                                                                                                                                                                           |
| <b>Output Arguments</b> | <p><b>T</b></p> <p>Output normally written to the command window during the evaluation of <code>expression</code>, except for error messages, returned in a character array. The lines in <code>T</code> are separated by <code>\n</code> characters.</p> <p><b>output1,...,outputN</b></p> <p>Outputs from the evaluated expression.</p>                                                                                                                                                                                       |
| <b>See Also</b>         | <code>eval</code>   <code>evalin</code>   <code>assignin</code>   <code>feval</code>   <code>diary</code>   <code>input</code>   <code>more</code>                                                                                                                                                                                                                                                                                                                                                                              |

**Purpose**

Execute MATLAB expression in specified workspace

**Syntax**

```
evalin(ws, expression)
[a1, a2, a3, ...] = evalin(ws, expression)
```

**Description**

`evalin(ws, expression)` executes *expression*, a string containing any valid MATLAB expression, in the context of the workspace *ws*. *ws* can have a value of 'base' or 'caller' to denote the MATLAB base workspace or the workspace of the caller function. You can construct *expression* by concatenating substrings and variables inside square brackets:

```
expression = [string1, int2str(var), string2,...]
```

`[a1, a2, a3, ...] = evalin(ws, expression)` executes *expression* and returns the results in the specified output variables. Using the `evalin` output argument list is recommended over including the output arguments in the expression string:

```
evalin(ws, '[a1, a2, a3, ...] = function(var)')
```

The above syntax avoids strict checking by the MATLAB parser and can produce untrapped errors and other unexpected behavior.

**Tips**

The MATLAB base workspace is the workspace that is seen from the MATLAB command line (when not in the debugger). The caller workspace is the workspace of the function that called the currently running function. Note that the base and caller workspaces are equivalent in the context of a function that is invoked from the MATLAB command line.

`evalin('caller', expression)` finds only *variables* in the caller's workspace; it does not find *functions* in the caller. For this reason, you cannot use `evalin` to construct a handle to a function that is defined in the caller.

If you use `evalin('caller', expression)` in the MATLAB debugger after having changed your local workspace context with `dbup` or `dbdown`,

# evalin

---

MATLAB evaluates the expression in the context of the function that is one level up in the stack from your current workspace context.

## Examples

This example extracts the value of the variable `var` in the MATLAB base workspace and captures the value in the local variable `v`:

```
v = evalin('base', 'var');
```

## Limitation

`evalin` cannot be used recursively to evaluate an expression. For example, a sequence of the form `evalin('caller', 'evalin(''caller'', ''x'')` doesn't work.

## See Also

`feval` | `evalc` | `eval` | `assignin` | `try`

**Purpose**

Base class for all data objects passed to event listeners

**Description**

The event package contains the `event.EventData` class, which defines the data objects passed to event listeners. If you want to provide additional information to event listeners, you can do so by subclassing `event.EventData`. See “Defining Event-Specific Data” for more information.

---

**Note** Subclasses of `event.EventData` must set the class `ConstructOnLoad` attribute.

---

**Properties**

The `event.EventData` class defines two properties and no methods:

- `EventName` — The name of the event described by this data object.
- `Source` — The source object whose class defines the event described by the data object.

**See Also**

`event.PropertyEvent`

**How To**

- “Learning to Use Events and Listeners”
- “Customizing Event Data”

# event.listener

---

**Purpose** Class defining listener objects

**Syntax** `lh = event.listener(Hobj, 'EventName', @CallbackFunction)`

**Description** The `event.listener` class defines listener objects. Listener objects respond to the specified event and identify the callback function to invoke when the event is triggered.

`lh = event.listener(Hobj, 'EventName', @CallbackFunction)` creates an `event.listener` object, `lh`, for the event named in `EventName`, on the specified object, `Hobj`.

If `Hobj` is an array of object handles, the listener responds to the named event on any of the objects referenced in the array.

The listener callback function must accept at least two input arguments. For example,

```
function CallbackFunction(source, eventData)
 ...
end
```

where `source` is the object that is the source of the event and `eventData` is an `event.EventData` object.

The `event.listener` class is a handle class.

## Limiting Listener Lifecycle

Generally, you create a listener object using `addListener`. However, you can call the `event.listener` constructor directly to create a listener. When you use the `event.listener` constructor, the listener's lifecycle is not tied to the object(s) being listened to—once the listener object goes out of scope, the listener no longer exists. See “Ways to Create Listeners” for more information on creating listener objects.

## Removing a Listener

If you call `delete(lh)` on the listener object, the listener ceases to exist, which means the event no longer causes the listener callback function to execute.

## Disabling a Listener

You can enable or disable a listener by setting the value of the listener's `Enabled` property (see Properties table below).

## More Information on Events and Listeners

See “Events” for more information and examples of how to use events and listeners.

## Properties

| Property  | Purpose                                                                                                                                                                                                                                                                                                                                                                                                           |
|-----------|-------------------------------------------------------------------------------------------------------------------------------------------------------------------------------------------------------------------------------------------------------------------------------------------------------------------------------------------------------------------------------------------------------------------|
| Source    | Cell array of source objects                                                                                                                                                                                                                                                                                                                                                                                      |
| EventName | Name of the event                                                                                                                                                                                                                                                                                                                                                                                                 |
| Callback  | Function to execute when the event is triggered and the <code>Enabled</code> property is set to <code>true</code>                                                                                                                                                                                                                                                                                                 |
| Enabled   | The callback executes when the event occurs if and only if <code>Enabled</code> is set to <code>true</code> (the default).                                                                                                                                                                                                                                                                                        |
| Recursive | <p>When <code>false</code> (the default), this listener does not execute recursively. Therefore, if the callback triggers its own event, the listener does not execute again.</p> <p>When <code>true</code>, the listener callback can cause the same event that triggered the callback. This scheme can lead to infinite recursion, which ends when the MATLAB recursion limit eventually triggers an error.</p> |

## See Also

`addlistener` | `delete` | `event.proplistener`

# event.PropertyEvent

---

**Purpose** Data for property events

**Description** The `event.PropertyEvent` class defines the data objects passed to listeners of the `meta.property` events:

- `PreGet`
- `PostGet`
- `PreSet`
- `PostSet`

`event.PropertyEvent` is a sealed subclass of `event.EventData` (i.e., you cannot subclass `event.PropertyEvent`).

**Properties** `event.PropertyEvent` inherits the first two properties from the `event.EventData`, and defines one new property:

- `EventName` — One of the four event names listed in the Description section
- `Source` — `meta.property` object that triggers the event
- `AffectedObject` — The object whose property is affected.

**See Also** `event.EventData` | `meta.property`

**How To** • “Listen for Changes to Property Values”



**Purpose**

Define listener object for property events

**Syntax**

```
lh = event.proplistener(Hobj, Properties, 'PropEvent',
 @CallbackFunction)
```

**Description**

lh = event.proplistener(Hobj, Properties, 'PropEvent', @CallbackFunction) creates a property listener object for one or more properties on the specified object.

- **Hobj** — handle of object whose property or properties are to be listened to. If Hobj is an array, the listener responds to the named event on all objects in the array.
- **Properties** — an object array or a cell array of meta.property object handles representing the properties to which you want to listen.
- **PropEvent** — must be one of the strings: PreSet, PostSet, PreGet, PostGet
- **@CallbackFunction** — function handle to the callback function that executes when the event occurs.

The event.proplistener class defines property event listener objects. It is a subclass of the event.listener class and adds one property to those defined by event.listener:

- **Object** — Cell array of objects whose property events are being listened to.

You can call the event.proplistener constructor instead of calling addlistener to create a property listener. However, when you do not use addlistener, the listener's lifecycle is not tied to the object(s) being listened to.

See “Listen for Changes to Property Values”.

See “Getting Information About Properties” for more information on using meta.property objects.

**See Also**

event.listener | addlistener

# eventlisteners

---

**Purpose** List event handler functions associated with COM object events

**Syntax**  
`info = h.eventlisteners`  
`info = eventlisteners(h)`

**Description** `info = h.eventlisteners` lists the events and their event handler routines registered with COM object `h`. The function returns a cell array of strings `info`, with each row containing the name of a registered event and the handler routine for that event. If the object has no registered events, `eventlisteners` returns an empty cell array. You can register events either when you create the control, using `actxcontrol`, or at any time afterwards, using `registerevent`.

`info = eventlisteners(h)` is an alternate syntax.

COM functions are available on Microsoft Windows systems only.

**Examples** Manage events for an instance of the MATLAB control `mwsamp`:

```
f = figure('position', [100 200 200 200]);
%Create an mwsamp control and
%register the Click event
h = actxcontrol('mwsamp.mwsampctrl.2', ...
 [0 0 200 200], f, ...
 {'Click' 'myclick'});
h.eventlisteners
```

```
ans =
 'Click' 'myclick'
```

MATLAB displays the event name and its event handler, `myclick`.

---

Register two more events, `Db1Click` and `MouseDown`:

```
h.registerevent({'Db1Click', 'my2click'; 'MouseDown' 'mymoused'});
h.eventlisteners
```

```
ans =
```

```
'Click' 'myclick'
'Dblclick' 'my2click'
'MouseDown' 'mymoused'
```

MATLAB displays all event names and handlers.

---

Unregister all events for the control:

```
h.unregisterallevents
h.eventlisteners
```

```
ans =
 {}
```

MATLAB displays an empty cell array, indicating the control has no registered events.

## See Also

```
events (COM) | registerevent | unregisterevent |
unregisterallevents | isevent | actxcontrol
```

# events

---

**Purpose** Event names

**Syntax** `events('classname')`  
`events(obj)`  
`e = events(...)`

**Description** `events('classname')` displays the names of the public events for the MATLAB class `classname`, including events inherited from superclasses.

`events(obj)` `obj` is a scalar or array of objects of a MATLAB class.

`e = events(...)` returns the event names in a cell array of strings.

An event is public when the value of its `ListenAccess` attribute is `public` and its `Hidden` attribute value is `false` (default values for both attributes). See “Event Attributes” for a complete list of attributes.

`events` is also a MATLAB class-definition keyword. See `classdef` for more information on class definition keywords.

**Examples** Get the names of the public events for the `handle` class:

```
events('handle')
Events for class handle:

 ObjectBeingDestroyed
```

**See Also** `properties` | `methods`

**Tutorials**

- “Events”

**Purpose** List of events COM object can trigger

**Syntax**  
 S = h.events  
 S = events(h)

**Description** S = h.events returns structure array S containing all events, both registered and unregistered, known to the COM object, and the function prototype used when calling the event handler routine. For each array element, the structure field is the event name and the contents of that field is the function prototype for that event's handler.  
 S = events(h) is an alternate syntax.

**Tips** COM functions are available on Microsoft Windows systems only.

**Examples** **List Control Events Example**

Create an mwsamp control and list all events:

```
f = figure ('position', [100 200 200 200]);
h = actxcontrol ('mwsamp.mwsampctrl.2', [0 0 200 200], f);
h.events
```

MATLAB software displays information similar to:

```
Click = void Click()
Db1Click = void Db1Click()
MouseDown = void MouseDown(int16 Button, int16 Shift,
 Variant x, Variant y)
Event_Args = void Event_Args(int16 typeshort, int32 typelong,
 double typedouble, string typestring, bool typebool)
```

Assign the output to a variable and get one field of the returned structure:

```
ev = h.events;
ev.MouseDown
```

## events (COM)

---

MATLAB displays:

```
ans =
 void MouseDown(int16 Button, int16 Shift, Variant x, Variant y)
```

### List Workbook Events Example

Open a Microsoft Excel application and list all events for a Workbook object:

```
myApp = actxserver('Excel.Application');
wbs = myApp.Workbooks;
wb = wbs.Add;
wb.events
```

The MATLAB software displays all events supported by the Workbook object.

```
Open = void Open()
Activate = void Activate()
Deactivate = void Deactivate()
BeforeClose = void BeforeClose(bool Cancel)
:
:
```

### See Also

[isevent](#) | [eventlisteners](#) | [registerevent](#) | [unregisterevent](#)  
| [unregisterallevts](#)

**Purpose** Execute MATLAB command in Automation server

**Syntax** **IDL Method Signature**

```
BSTR Execute([in] BSTR command)
```

**Microsoft Visual Basic® Client**

```
Execute(command As String) As String
```

**MATLAB Client**

```
result = h.Execute('command')
result = Execute(h, 'command')
result = invoke(h, 'Execute', 'command')
```

**Description**

The `Execute` function executes the MATLAB statement specified by the string `command` in the MATLAB Automation server attached to handle `h`.

The server returns output from the command in the string, `result`. The `result` string also contains any warning or error messages that might have been issued by MATLAB software as a result of the command.

Note that if you terminate the MATLAB command string with a semicolon and there are no warnings or error messages, `result` might be returned empty.

**Tips**

If you want to be able to display output from `Execute` in the client window, you must specify an output variable (i.e., `result` in the above syntax statements).

Server function names, like `Execute`, are case sensitive when used with dot notation (the first syntax shown).

If there is an error, the `Execute` function returns the MATLAB error message with the characters `???` prepended to the text.

COM functions are available on Microsoft Windows systems only.

**Examples**

From a Visual Basic .NET client, execute the MATLAB `version` function in the server and return the output to the client.

# Execute

---

```
Dim Matlab As Object
Dim server_version As String
Matlab = CreateObject("matlab.application")
server_version = Matlab.Execute("version")
```

## See Also

[Feval](#) | [PutFullMatrix](#) | [GetFullMatrix](#) | [PutCharArray](#) | [GetCharArray](#)



**Purpose** Read EXIF information from JPEG and TIFF image files

## Syntax

---

**Note** `exifread` will be removed in a future release. Use `imfinfo` instead.

---

```
output = exifread(filename)
```

## Description

`output = exifread(filename)` reads the Exchangeable Image File Format (EXIF) data from the file specified by the string `filename`. `filename` must specify a JPEG or TIFF image file. `output` is a structure containing metadata values about the image or images in `imagefile`.

---

**Note** `exifread` returns all EXIF tags and does not process them in any way.

---

EXIF is a standard used by digital camera manufacturers to store information in the image file, such as, the make and model of a camera, the time the picture was taken and digitized, the resolution of the image, exposure time, and focal length. For more information about EXIF and the meaning of metadata attributes, see <http://www.exif.org/>.

## See Also

`imfinfo` | `imread`

# exist

---

**Purpose** Check existence of variable, function, folder, or class

**Syntax**  
`exist name`  
`exist name kind`  
`A = exist('name','kind')`

**Description** `exist name` returns the status of name:

|   |                                                                                                                                                                                                                                                                                              |
|---|----------------------------------------------------------------------------------------------------------------------------------------------------------------------------------------------------------------------------------------------------------------------------------------------|
| 0 | name does not exist.                                                                                                                                                                                                                                                                         |
| 1 | name is a variable in the workspace.                                                                                                                                                                                                                                                         |
| 2 | One of the following is true: <ul style="list-style-type: none"><li>• name exists on your MATLAB search path as a file with extension <code>.m</code>.</li><li>• name is the name of an ordinary file on your MATLAB search path.</li><li>• name is the full pathname to any file.</li></ul> |
| 3 | name exists as a MEX-file on your MATLAB search path.                                                                                                                                                                                                                                        |
| 4 | name exists as a Simulink model or library file on your MATLAB search path.                                                                                                                                                                                                                  |
| 5 | name is a built-in MATLAB function.                                                                                                                                                                                                                                                          |
| 6 | name is a P-file on your MATLAB search path.                                                                                                                                                                                                                                                 |
| 7 | name is a folder.                                                                                                                                                                                                                                                                            |
| 8 | name is a class. ( <code>exist</code> returns 0 for Java classes if you start MATLAB with the <code>-nojvm</code> option.)                                                                                                                                                                   |

If name is a class, then `exist('name')` returns an 8. However, if name is a class file, then `exist('name')` returns a 2.

If a file or folder is not on the search path, then name must specify either a full pathname, a partial pathname relative to `MATLABPATH`, a partial

pathname relative to your current folder, or the file or folder must reside in your current working folder.

If `name` specifies a filename, that filename may include an extension to preclude conflicting with other similar filenames. For example, `exist('file.ext')`.

`exist name kind` returns the status of `name` for the specified `kind`. If `name` of type `kind` does not exist, it returns 0. The `kind` argument may be one of the following:

|                      |                                     |
|----------------------|-------------------------------------|
| <code>builtin</code> | Checks only for built-in functions. |
| <code>class</code>   | Checks only for classes.            |
| <code>dir</code>     | Checks only for folders.            |
| <code>file</code>    | Checks only for files or folders.   |
| <code>var</code>     | Checks only for variables.          |

If you do not specify a `kind` argument, and `name` belongs to more than one of these categories, `exist` returns one value according to the order of evaluation shown in the table below. For example, if `name` matches both a folder and a file that defines a MATLAB function, `exist` returns 7, identifying it as a folder.

| <b>Order of Evaluation</b> | <b>Return Value</b> | <b>Type of Entity</b> |
|----------------------------|---------------------|-----------------------|
| 1                          | 1                   | Variable              |
| 2                          | 5                   | Built-in              |
| 3                          | 7                   | Folder                |
| 4                          | 3                   | MEX-file              |
| 5                          | 4                   | SLX or MDL-file       |
| 6                          | 6                   | P-file                |

| Order of Evaluation | Return Value | Type of Entity  |
|---------------------|--------------|-----------------|
| 7                   | 2            | MATLAB function |
| 8                   | 8            | Class           |

`A = exist('name', 'kind')` is the function form of the syntax.

## Tips

If `name` specifies a filename, MATLAB attempts to locate the file, examines the filename extension, and determines the value to return based on the extension alone. MATLAB does not examine the contents or internal structure of the file.

You can specify a partial path to a folder or file. A partial pathname is a pathname relative to the MATLAB path that contains only the trailing one or more components of the full pathname. For example, both of the following commands return 2, identifying `mkdir.m` as a MATLAB function. The first uses a partial pathname:

```
exist('matlab/general/mkdir.m')
exist([matlabroot '/toolbox/matlab/general/mkdir.m'])
```

To check for the existence of more than one variable, use the `ismember` function. For example,

```
a = 5.83;
c = 'teststring';
ismember({'a', 'b', 'c'}, who)
```

```
ans =
 1 0 1
```

## Examples

This example uses `exist` to check whether a MATLAB function is a built-in function or a file:

```
type = exist('plot')
type =
```

5

This indicates that `plot` is a built-in function.

Run `exist` on a class folder and then on the constructor within that folder:

```
exist('@portfolio')
ans =
 7 % @portfolio is a folder

exist('@portfolio\portfolio')
ans =
 2 % portfolio is a MATLAB function
```

The following example indicates that `testresults` is both a variable in the workspace and a folder on the search path:

```
exist('testresults','var')
ans =
 1
exist('testresults','dir')
ans =
 7
```

## See Also

`assignin` | `computer` | `dir` | `evalin` | `help` | `inmem` | `isfield` | `isempty` | `lookfor` | `mfilename` | `what` | `which` | `who`

# exit

---

|                     |                                                                                                                                                                                                                                                                                                                                                                       |
|---------------------|-----------------------------------------------------------------------------------------------------------------------------------------------------------------------------------------------------------------------------------------------------------------------------------------------------------------------------------------------------------------------|
| <b>Purpose</b>      | Terminate MATLAB program (same as quit)                                                                                                                                                                                                                                                                                                                               |
| <b>Alternatives</b> | As an alternative to the <code>exit</code> function, click the Close box in the MATLAB desktop.                                                                                                                                                                                                                                                                       |
| <b>Syntax</b>       | <code>exit</code><br><code>exit(code)</code>                                                                                                                                                                                                                                                                                                                          |
| <b>Description</b>  | <p><code>exit</code> terminates the current session of MATLAB after running <code>finish.m</code>, if the file <code>finish.m</code> exists. It performs the same as <code>quit</code> and takes the same termination options, such as <b>force</b>.</p> <p><code>exit(code)</code> returns exit code when calling a MATLAB command from the system command line.</p> |
| <b>See Also</b>     | <code>quit</code>   <code>finish</code>                                                                                                                                                                                                                                                                                                                               |
| <b>How To</b>       | <ul style="list-style-type: none"><li>• “Stop Execution”</li></ul>                                                                                                                                                                                                                                                                                                    |

**Purpose** Exponential

**Syntax**  $Y = \exp(X)$

**Description**  $Y = \exp(X)$  returns the exponential for each element of array  $X$ . The function accepts both real and complex inputs. For real values of  $X$  in the interval  $(-\text{Inf}, \text{Inf})$ ,  $\exp$  returns real values in the interval  $(0, \text{Inf})$ . For complex values of  $X$ ,  $\exp$  returns complex values.

**Input Arguments**

**X - Input array**

scalar | vector | matrix | multidimensional array

Input array, specified as a scalar, vector, matrix, or multidimensional array.

**Data Types**

single | double

**Complex Number Support:** Yes

**Examples**

**Calculate Scalar Exponential Values**

Examine several common values of the exponential function.

Calculate the exponential of 0.

```
exp(0)
```

```
ans =
```

```
1
```

The result is 1, which is the y-intercept of the  $\exp$  function.

Calculate the exponential of 1.

```
exp(1)
```

```
ans =
```

2.7183

The result is equal to Euler's number,  $e$ .

Calculate the exponential of  $i\pi$ .

```
exp(1i*pi)
```

```
ans =
```

```
-1.0000 + 0.0000i
```

The result of -1 is due to Euler's famous formula

$$e^{i\theta} = \cos\theta + i\sin\theta.$$

Calculate the exponential of -Inf.

```
exp(-Inf)
```

```
ans =
```

```
0
```

The result is 0 since `exp` returns small values for negative inputs.

## **Plot Real-Valued Exponential Function**

Define the domain.

```
X = (-1:0.5:5)';
```

Calculate the exponential of the vector, X.

```
Y = exp(X)
```

```
Y =
```



---

```
0.3679
0.6065
1.0000
1.6487
2.7183
4.4817
7.3891
12.1825
20.0855
33.1155
54.5982
90.0171
148.4132
```

The result is a vector of exponential values.

Plot the function values.

```
plot(X,Y,'LineWidth',1.5)
grid on;
title('Real-Valued Exponential Function');
xlabel('X'); ylabel('Y');
```

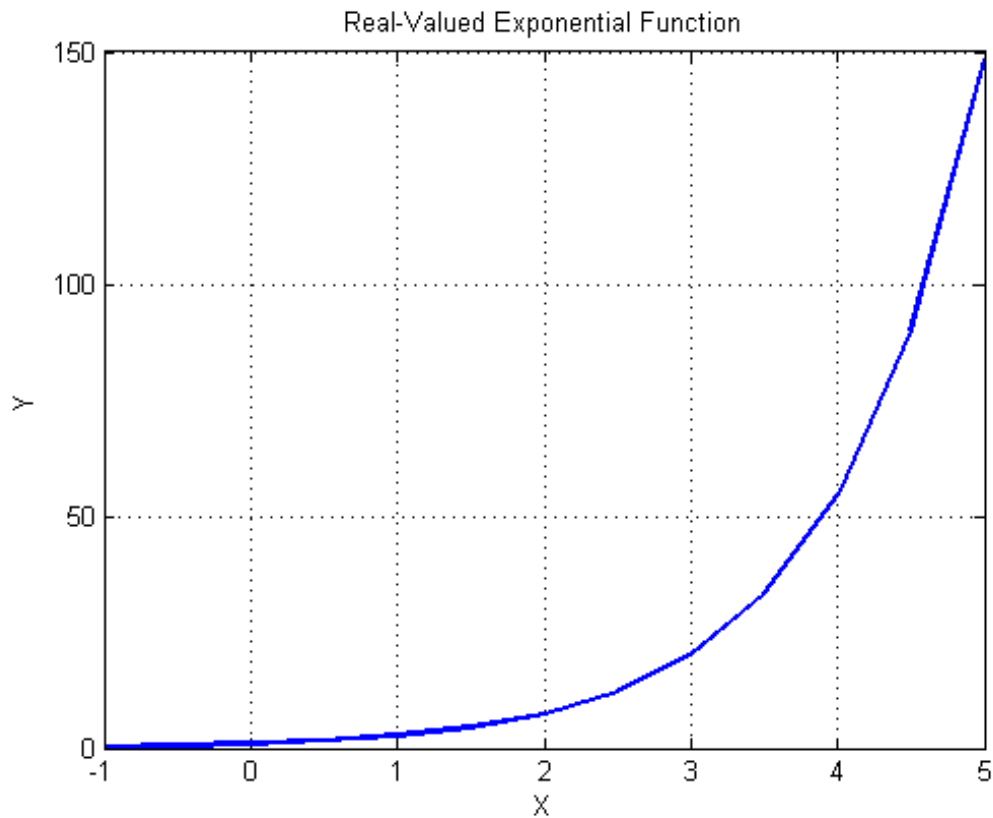

The real-valued exponential function maps values in the domain of all real numbers to the range of  $(0, \infty)$ .

### **Plot Complex-Valued Exponential Function**

Define a grid of values for the (X,Y) domain.

```
[X,Y] = meshgrid(0:0.5:10,0:0.5:10);
```

Calculate the complex exponential on the grid.

```
Z = exp(X+1i*Y);
```

Make a surface plot of the imaginary portion of the function.

```
surf(X,Y,imag(Z))
grid on; hold on;
xlabel('X'); ylabel('Y'); zlabel('Z');
view(44,42)
```

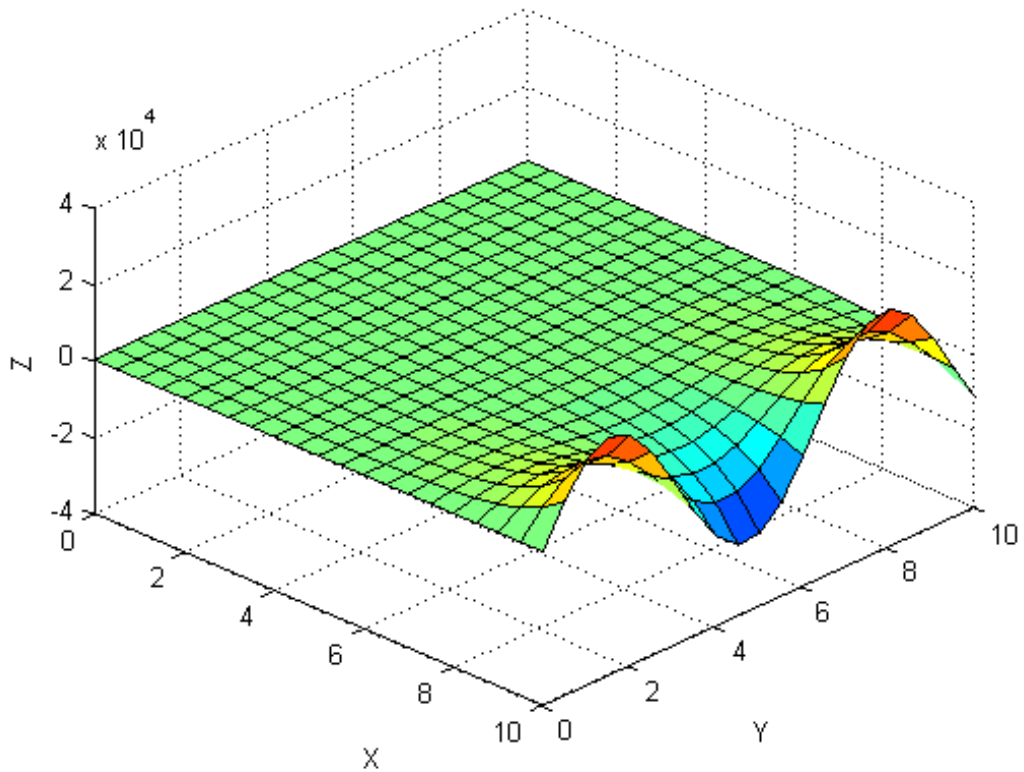

exp is a continuous function on the complex plane.

Plot the real portion of the function in the same figure.

```
surf(X,Y,real(Z))
view(63,14)
```

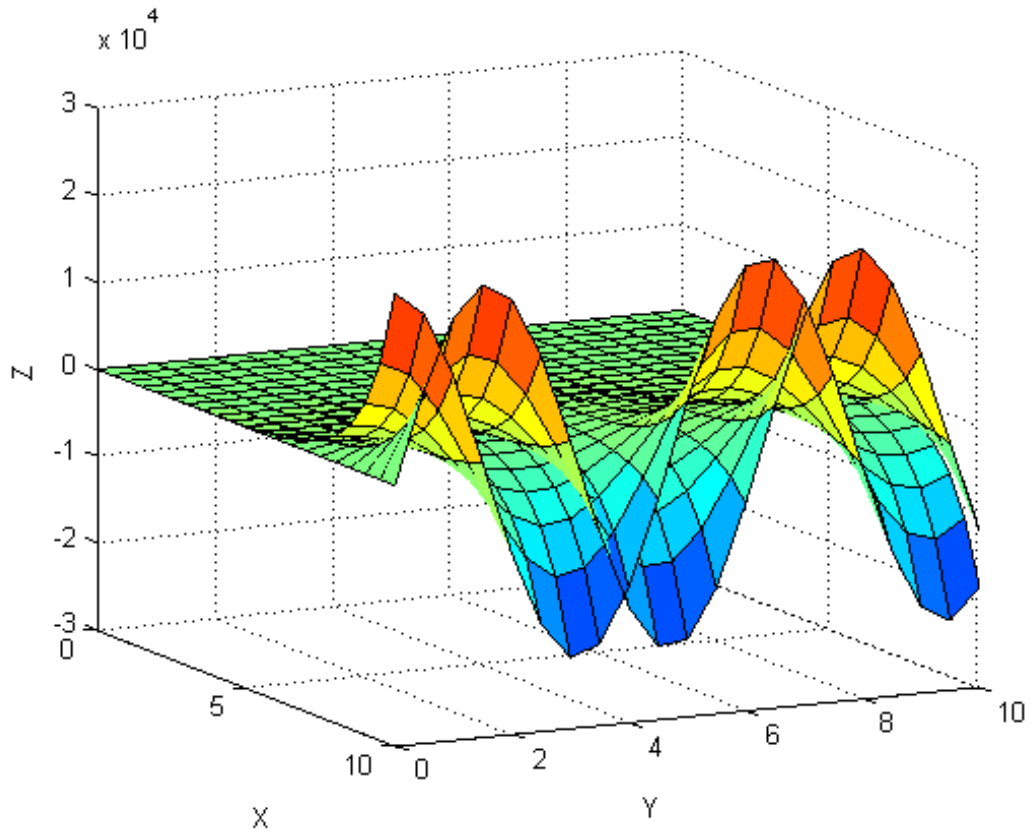

In this plot, the real and complex portions of the function are 90 degrees out of phase. Analytically, this is because the real portion depends on  $\cos$ , whereas the complex portion depends on  $\sin$ .

**Algorithms**

For complex inputs  $z = x + 1i*y$ , the `exp` function calculates the complex exponential `exp(x).*(cos(y) + 1i*sin(y))`.

**See Also**

`expm` | `log` | `expm1` | `log10` | `expint` | `power` | `mpower`

# expint

---

**Purpose** Exponential integral

**Syntax**  $Y = \text{expint}(X)$

**Definitions** The exponential integral computed by this function is defined as

$$E_1(x) = \int_x^{\infty} e^{-t} / t dt$$

Another common definition of the exponential integral function is the Cauchy principal value integral

$$\text{Ei}(x) = \int_{-\infty}^x e^t / t dt$$

which, for real positive  $x$ , is related to `expint` as

$$E_1(-x) = -\text{Ei}(x) - i\pi$$

**Description**  $Y = \text{expint}(X)$  evaluates the exponential integral for each element of  $X$ .

**References** [1] Abramowitz, M. and I. A. Stegun. *Handbook of Mathematical Functions*. Chapter 5, New York: Dover Publications, 1965.

**Purpose** Matrix exponential

**Syntax**  $Y = \text{expm}(X)$

**Description**  $Y = \text{expm}(X)$  computes the matrix exponential of  $X$ .

Although it is not computed this way, if  $X$  has a full set of eigenvectors  $V$  with corresponding eigenvalues  $D$ , then

$$[V,D] = \text{EIG}(X) \text{ and } \text{EXPM}(X) = V \cdot \text{diag}(\exp(\text{diag}(D))) / V$$

Use `exp` for the element-by-element exponential.

**Algorithms** `expm` uses the Padé approximation with scaling and squaring. See reference [3], below.

---

**Note** The files, `expdemo1.m`, `expdemo2.m`, and `expdemo3.m` illustrate the use of Padé approximation, Taylor series approximation, and eigenvalues and eigenvectors, respectively, to compute the matrix exponential. References [1] and [2] describe and compare many algorithms for computing a matrix exponential.

---

**Examples** This example computes and compares the matrix exponential of  $A$  and the exponential of  $A$ .

```
A = [1 1 0
 0 0 2
 0 0 -1];
```

```
expm(A)
ans =
 2.7183 1.7183 1.0862
 0 1.0000 1.2642
 0 0 0.3679
```

```
exp(A)
ans =
 2.7183 2.7183 1.0000
 1.0000 1.0000 7.3891
 1.0000 1.0000 0.3679
```

Notice that the diagonal elements of the two results are equal. This would be true for any triangular matrix. But the off-diagonal elements, including those below the diagonal, are different.

## References

- [1] Golub, G. H. and C. F. Van Loan, *Matrix Computation*, p. 384, Johns Hopkins University Press, 1983.
- [2] Moler, C. B. and C. F. Van Loan, “Nineteen Dubious Ways to Compute the Exponential of a Matrix,” *SIAM Review* 20, 1978, pp. 801–836. Reprinted and updated as “Nineteen Dubious Ways to Compute the Exponential of a Matrix, Twenty-Five Years Later,” *SIAM Review* 45, 2003, pp. 3–49.
- [3] Higham, N. J., “The Scaling and Squaring Method for the Matrix Exponential Revisited,” *SIAM J. Matrix Anal. Appl.*, 26(4) (2005), pp. 1179–1193.

## See Also

`exp` | `expm1` | `funm` | `logm` | `eig` | `sqrtm`



**Purpose** Compute  $\exp(x)-1$  accurately for small values of  $x$

**Syntax**  $y = \text{expm1}(x)$

**Description**  $y = \text{expm1}(x)$  computes  $\exp(x) - 1$ , compensating for the roundoff in  $\exp(x)$ .

For small  $x$ ,  $\text{expm1}(x)$  is approximately  $x$ , whereas  $\exp(x) - 1$  can be zero.

**See Also** `exp` | `expm` | `log1p`

# export2wsdlg

---

## Purpose

Export variables to workspace

## Syntax

```
export2wsdlg(checkboxlabels,defaultvariablenames,
itemstoexport)
export2wsdlg(checkboxlabels,defaultvariablenames,
itemstoexport,title)
export2wsdlg(checkboxlabels,defaultvariablenames,
itemstoexport,title,selected)
export2wsdlg(checkboxlabels,defaultvariablenames,
itemstoexport,title,selected,helpfunction)
export2wsdlg(checkboxlabels,defaultvariablenames,
itemstoexport,title,selected,helpfunction,functionlist)
hdialog = export2wsdlg(...)
[hdialog,ok_pressed] = export2wsdlg(...)
```

## Description

`export2wsdlg(checkboxlabels,defaultvariablenames,itemstoexport)` creates a dialog with a series of check boxes and edit fields. `checkboxlabels` is a cell array of labels for the check boxes. `defaultvariablenames` is a cell array of strings that serve as a basis for variable names that appear in the edit fields. `itemstoexport` is a cell array of the values to be stored in the variables. If there is only one item to export, `export2wsdlg` creates a text control instead of a check box.

---

**Note** By default, the dialog box is modal. A modal dialog box prevents the user from interacting with other windows before responding.

---

`export2wsdlg(checkboxlabels,defaultvariablenames,itemstoexport,title)` creates the dialog with `title` as its title.

`export2wsdlg(checkboxlabels,defaultvariablenames,itemstoexport,title,selected)` creates the dialog allowing the user to control which check boxes are checked. `selected` is a logical array whose length is the same as `checkboxlabels`. True indicates that the check box should initially be checked, false unchecked.

`export2wsdlg(checkboxlabels,defaultvariablenames, itemstoexport,title,selected,helpfunction)` creates the dialog with a help button. `helpfunction` is a callback that displays help.

`export2wsdlg(checkboxlabels,defaultvariablenames, itemstoexport,title,selected,helpfunction,functionlist)` creates a dialog that enables the user to pass in `functionlist`, a cell array of functions and optional arguments that calculate, then return the value to export. `functionlist` should be the same length as `checkboxlabels`.

`hdialog = export2wsdlg(...)` returns the handle of the dialog.

`[hdialog,ok_pressed] = export2wsdlg(...)` sets `ok_pressed` to true if the OK button is pressed, or false otherwise. If two return arguments are requested, `hdialog` is [] and the function does not return until the dialog is closed.

The user can edit the text fields to modify the default variable names. If the same name appears in multiple edit fields, `export2wsdlg` creates a structure using that name. It then uses the `defaultvariablenames` as field names for that structure.

The lengths of `checkboxlabels`, `defaultvariablenames`, `itemstoexport` and `selected` must all be equal.

The strings in `defaultvariablenames` must be unique.

## Examples

This example creates a dialog box that enables the user to save the variables `sumA` and/or `meanA` to the workspace. The dialog box title is `Save Sums to Workspace`.

```
A = randn(10,1);
checkLabels = {'Save sum of A to variable named:' ...
 'Save mean of A to variable named:'};
varNames = {'sumA','meanA'};
items = {sum(A),mean(A)};
export2wsdlg(checkLabels,varNames,items,...
 'Save Sums to Workspace');
```

## Purpose

Identity matrix

## Syntax

```
I = eye
I = eye(n)
I = eye(n,m)
I = eye(sz)

I = eye(classname)
I = eye(n,classname)
I = eye(n,m,classname)
I = eye(sz,classname)

I = eye('like',p)
I = eye(n,'like',p)
I = eye(n,m,'like',p)
I = eye(sz,'like',p)
```

## Description

`I = eye` returns the scalar, 1.

`I = eye(n)` returns an n-by-n identity matrix with ones on the main diagonal and zeros elsewhere.

`I = eye(n,m)` returns an n-by-m matrix with ones on the main diagonal and zeros elsewhere.

`I = eye(sz)` returns an array with ones on the main diagonal and zeros elsewhere. The size vector, `sz`, defines `size(I)`. For example, `eye([2,3])` returns a 2-by-3 array with ones on the main diagonal and zeros elsewhere.

`I = eye(classname)` returns a scalar, 1, where the string, `classname`, specifies the data type. For example, `eye('int8')` returns a scalar, 8-bit integer.

`I = eye(n,classname)` returns an n-by-n identity matrix of data type `classname`.

`I = eye(n,m,classname)` returns an n-by-m matrix of data type `classname` with ones on the main diagonal and zeros elsewhere.

`I = eye(sz,classname)` returns a matrix with ones on the main diagonal and zeros elsewhere. The size vector, `sz`, defines `size(I)` and `classname` defines `class(I)`.

`I = eye('like',p)` returns a scalar, 1, with the same data type, sparsity, and complexity (real or complex) as the numeric variable, `p`.

`I = eye(n, 'like', p)` returns an n-by-n identity matrix like `p`.

`I = eye(n,m, 'like', p)` returns an n-by-m matrix like `p`.

`I = eye(sz, 'like', p)` returns a matrix like `p` where the size vector, `sz`, defines `size(I)`.

## Input Arguments

### **n - Size of first dimension of I**

integer value

Size of first dimension of I, specified as an integer value.

- If `n` is the only integer input argument, then I is a square n-by-n identity matrix.
- If `n` is 0, then I is an empty matrix.
- If `n` is negative, then it is treated as 0.

### **Data Types**

double | single | int8 | int16 | int32 | int64 | uint8 |  
uint16 | uint32 | uint64

**m - Size of second dimension of I**

integer value

Size of second dimension of I, specified as an integer value.

- If m is 0, then I is an empty matrix.
- If m is negative, then it is treated as 0.

**Data Types**

double | single | int8 | int16 | int32 | int64 | uint8 |  
uint16 | uint32 | uint64

**sz - Size of I**

row vector of no more than two integer values

Size of I, specified as a row vector of no more than two integer values.

- If an element of sz is 0, then I is an empty matrix.
- If an element of sz is negative, then the element is treated as 0.

**Example:** sz = [2,3] defines I as a 2-by-3 matrix.

**Data Types**

double | single | int8 | int16 | int32 | int64 | uint8 |  
uint16 | uint32 | uint64

**classname - Output class**

'double' (default) | 'single' | 'int8' | 'uint8' | ...

Output class, specified as 'double', 'single', 'int8', 'uint8', 'int16', 'uint16', 'int32', 'uint32', 'int64', or 'uint64'.

**Data Types**

char

**p - Prototype**

numeric variable

Prototype, specified as a numeric variable.

**Data Types**

double | single | int8 | int16 | int32 | int64 | uint8 |  
uint16 | uint32 | uint64

**Complex Number Support:** Yes

**Examples****Square Identity Matrix**

Create a 4-by-4 identity matrix.

```
I = eye(4)
```

```
I =
```

```
 1 0 0 0
 0 1 0 0
 0 0 1 0
 0 0 0 1
```

**Rectangular Matrix**

Create a 2-by-3 identity matrix.

```
I = eye(2,3)
```

```
I =
```

```
 1 0 0
 0 1 0
```

**Identity Vector**

Create a 3-by-1 identity vector.

```
sz = [3,1];
```

```
I = eye(sz)
```

```
I =
```

```
 1
 0
```

0

### **Nondefault Numeric Data Type**

Create a 3-by-3 identity matrix whose elements are 32-bit unsigned integers.

```
I = eye(3, 'uint32'),
class(I)
```

I =

```
 1 0 0
 0 1 0
 0 0 1
```

ans =

uint32

### **Complex Identity Matrix**

Create a 2-by-2 identity matrix that is not real valued, but instead is complex like an existing array.

Define a complex vector.

```
p = [1+2i 3i];
```

Create an identity matrix that is complex like p.

```
I = eye(2, 'like', p)
```

I =

```
 1.0000 + 0.0000i 0.0000 + 0.0000i
 0.0000 + 0.0000i 1.0000 + 0.0000i
```



### Sparse Identity Matrix

Define a 5-by-5 sparse matrix.

```
p = sparse(5,5,pi);
```

Create a 5-by-5 identity matrix that is sparse like P.

```
I = eye(5, 'like', p)
```

```
I =
```

```
 (1,1) 1
 (2,2) 1
 (3,3) 1
 (4,4) 1
 (5,5) 1
```

### Size and Numeric Data Type Defined by Existing Array

Define a 2-by-2 matrix of single precision.

```
p = single([1 3 ; 2 4]);
```

Create an identity matrix that is the same size and data type as P.

```
I = eye(size(p), 'like', p),
class(I)
```

```
I =
```

```
 1 0
 0 1
```

```
ans =
```

```
single
```

**See Also**

speye | ones | zeros

**Concepts**

- “Class Support for Array-Creation Functions”

**Purpose** Easy-to-use contour plotter

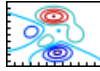

**Syntax**

```
ezcontour(fun)
ezcontour(fun,domain)
ezcontour(...,n)
ezcontour(axes_handle,...)
h = ezcontour(...)
```

**Description** `ezcontour(fun)` plots the contour lines of `fun(x,y)` using the `contour` function. `fun` is plotted over the default domain:  $-2\pi < x < 2\pi$ ,  $-2\pi < y < 2\pi$ .

`fun` can be a function handle for a MATLAB file function or an anonymous function (see [function handle](#) and “Anonymous Functions”) or a string (see [Tips](#)).

`ezcontour(fun,domain)` plots `fun(x,y)` over the specified domain. `domain` can be either a 4-by-1 vector `[xmin, xmax, ymin, ymax]` or a 2-by-1 vector `[min, max]` (where  $\min < x < \max$ ,  $\min < y < \max$ ).

`ezcontour(...,n)` plots `fun` over the default domain using an `n`-by-`n` grid. The default value for `n` is 60.

`ezcontour(axes_handle,...)` plots into the axes with handle `axes_handle` instead of the current axes (`gca`).

`h = ezcontour(...)` returns the handle to a contour object in `h`. `ezcontour` automatically adds a title and axis labels.

**Tips** **Passing the Function as a String**

Array multiplication, division, and exponentiation are always implied in the string expression you pass to `ezcontour`. For example, the MATLAB syntax for a contour plot of the expression

```
sqrt(x.^2 + y.^2)
```

is written as

```
ezcontour('sqrt(x^2 + y^2)')
```

That is,  $x^2$  is interpreted as  $x.^2$  in the string you pass to `ezcontour`.

If the function to be plotted is a function of the variables  $u$  and  $v$  (rather than  $x$  and  $y$ ), the domain endpoints `umin`, `umax`, `vmin`, and `vmax` are sorted alphabetically. Thus, `ezcontour('u^2 - v^3', [0,1], [3,6])` plots the contour lines for  $u^2 - v^3$  over  $0 < u < 1$ ,  $3 < v < 6$ .

## Passing a Function Handle

Function handle arguments must point to functions that use MATLAB syntax. For example, the following statements define an anonymous function and pass the function handle `fh` to `ezcontour`.

```
fh = @(x,y) sqrt(x.^2 + y.^2);
ezcontour(fh)
```

When using function handles, you must use the array power, array multiplication, and array division operators (`.^`, `.*`, `./`) since `ezcontour` does not alter the syntax, as in the case with string inputs.

## Passing Additional Arguments

If your function has additional parameters, for example, `k` in `myfun`:

```
function z = myfun(x,y,k)
z = x.^k - y.^k - 1;
```

then use an anonymous function to specify that parameter:

```
ezcontour(@(x,y)myfun(x,y,2))
```

## Examples

### Create Contour Plot of Mathematical Expression

This mathematical expression defines a function of two variables,  $x$  and  $y$ .

$$f(x, y) = 3(1 - x)^2 e^{-x^2 - (y+1)^2} - 10 \left( \frac{x}{5} - x^3 - y^5 \right) e^{-x^2 - y^2} - \frac{1}{3} e^{-(x+1)^2 - y^2}$$

The ezcontour function requires a function handle argument. Write this mathematical expression in MATLAB® syntax as an anonymous function with handle f. You can define an anonymous function in the command window without creating a separate file. For convenience, write the function on three lines.

```
f = @(x,y) 3*(1-x).^2.*exp(-(x.^2) - (y+1).^2) ...
- 10*(x/5 - x.^3 - y.^5).*exp(-x.^2-y.^2) ...
- 1/3*exp(-(x+1).^2 - y.^2);
```

Pass the function handle, f, to ezcontour. Specify a domain from -3 to 3 in both the x-direction and y-direction and use a 49-by-49 computational grid.

```
ezcontour(f, [-3,3], 49)
```

## ezcontour

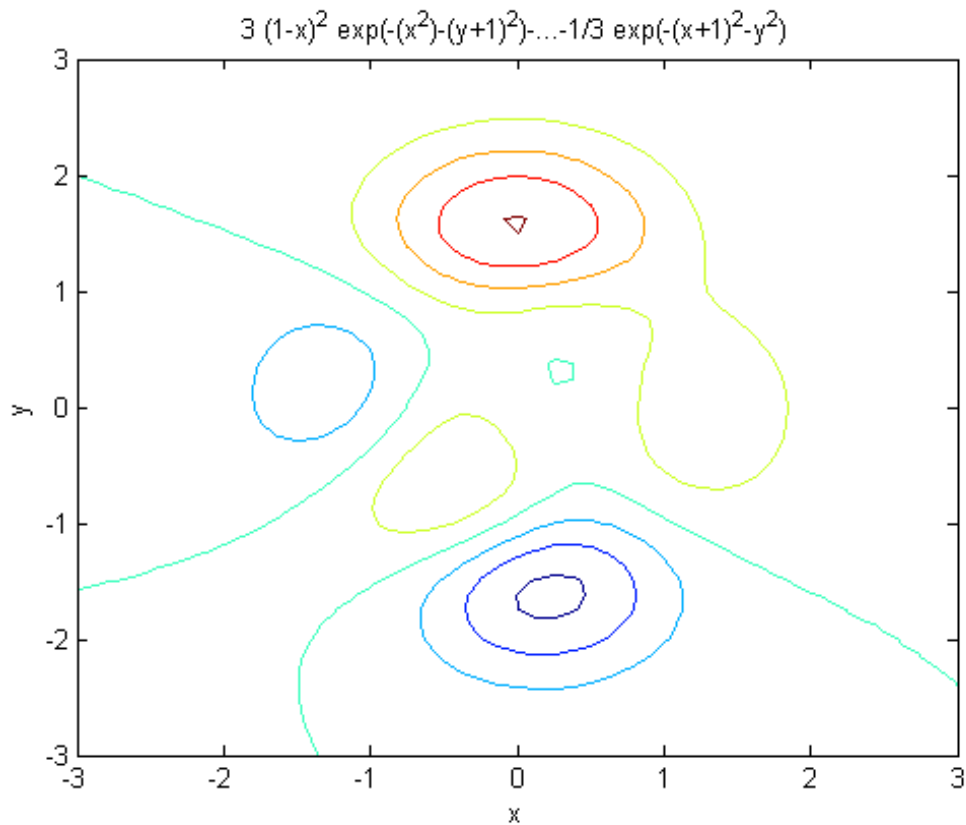

In this particular case, the title string is too long to fit at the top of the graph so MATLAB® abbreviates the string.

### See Also

[contour](#) | [ezcontourf](#) | [ezmesh](#) | [ezmeshc](#) | [ezplot](#) | [ezplot3](#) | [ezpolar](#) | [ezsurf](#) | [ezsurfz](#) | [function\\_handle](#)

**Purpose** Easy-to-use filled contour plotter



**Syntax**

```
ezcontourf(fun)
ezcontourf(fun, domain)
ezcontourf(..., n)
ezcontourf(axes_handle, ...)
h = ezcontourf(...)
```

**Description** `ezcontourf(fun)` plots the contour lines of `fun(x,y)` using the `contourf` function. `fun` is plotted over the default domain:  $-2\pi < x < 2\pi$ ,  $-2\pi < y < 2\pi$ .

`fun` can be a function handle or a string (see Tips).

`ezcontourf(fun, domain)` plots `fun(x,y)` over the specified domain. `domain` can be either a 4-by-1 vector `[xmin, xmax, ymin, ymax]` or a 2-by-1 vector `[min, max]`, where  $\min < x < \max$ ,  $\min < y < \max$ .

`ezcontourf(..., n)` plots `fun` over the default domain using an `n`-by-`n` grid. The default value for `n` is 60.

`ezcontourf(axes_handle, ...)` plots into the axes with the handle `axes_handle` instead of into the current axes (`gca`).

`h = ezcontourf(...)` returns the handle to a contour object in `h`.

`ezcontourf` automatically adds a title and axis labels.

**Tips** **Passing the Function as a String**

Array multiplication, division, and exponentiation are always implied in the string expression you pass to `ezcontourf`. For example, the MATLAB syntax for a filled contour plot of the expression

```
sqrt(x.^2 + y.^2);
```

is written as

```
ezcontourf('sqrt(x^2 + y^2)')
```

That is,  $x^2$  is interpreted as  $x.^2$  in the string you pass to `ezcontourf`.

If the function to be plotted is a function of the variables  $u$  and  $v$  (rather than  $x$  and  $y$ ), then the domain endpoints `umin`, `umax`, `vmin`, and `vmax` are sorted alphabetically. Thus, `ezcontourf('u^2 - v^3',[0,1],[3,6])` plots the contour lines for  $u^2 - v^3$  over  $0 < u < 1$ ,  $3 < v < 6$ .

## Passing a Function Handle

Function handle arguments must point to functions that use MATLAB syntax. For example, the following statements define an anonymous function and pass the function handle `fh` to `ezcontourf`.

```
fh = @(x,y) sqrt(x.^2 + y.^2);
ezcontourf(fh)
```

When using function handles, you must use the array power, array multiplication, and array division operators (`.^`, `.*`, `./`) since `ezcontourf` does not alter the syntax, as in the case with string inputs.

## Passing Additional Arguments

If your function has additional parameters, for example, `k` in `myfun`:

```
function z = myfun(x,y,k)
z = x.^k - y.^k - 1;
```

then you can use an anonymous function to specify that parameter:

```
ezcontourf(@(x,y)myfun(x,y,2))
```

## Examples

### Create Filled Contour Plot of Mathematical Expression

This mathematical expression defines a function of two variables,  $x$  and  $y$ .

$$f(x, y) = 3(1 - x)^2 e^{-x^2 - (y+1)^2} - 10 \left( \frac{x}{5} - x^3 - y^5 \right) e^{-x^2 - y^2} - \frac{1}{3} e^{-(x+1)^2 - y^2}$$



The `ezcontourf` function requires a function handle argument. Write this mathematical expression in MATLAB® syntax as an anonymous function with handle `f`. You can define an anonymous function in the command window without creating a separate file. For convenience, write the function on three lines.

```
f = @(x,y) 3*(1-x).^2.*exp(-(x.^2) - (y+1).^2) ...
 - 10*(x/5 - x.^3 - y.^5).*exp(-x.^2-y.^2) ...
 - 1/3*exp(-(x+1).^2 - y.^2);
```

Pass the function handle, `f`, to `ezcontourf`. Specify a domain from -3 to 3 in both the x-direction and y-direction and use a 49-by-49 computational grid.

```
ezcontourf(f, [-3,3],49)
```

# ezcontourf

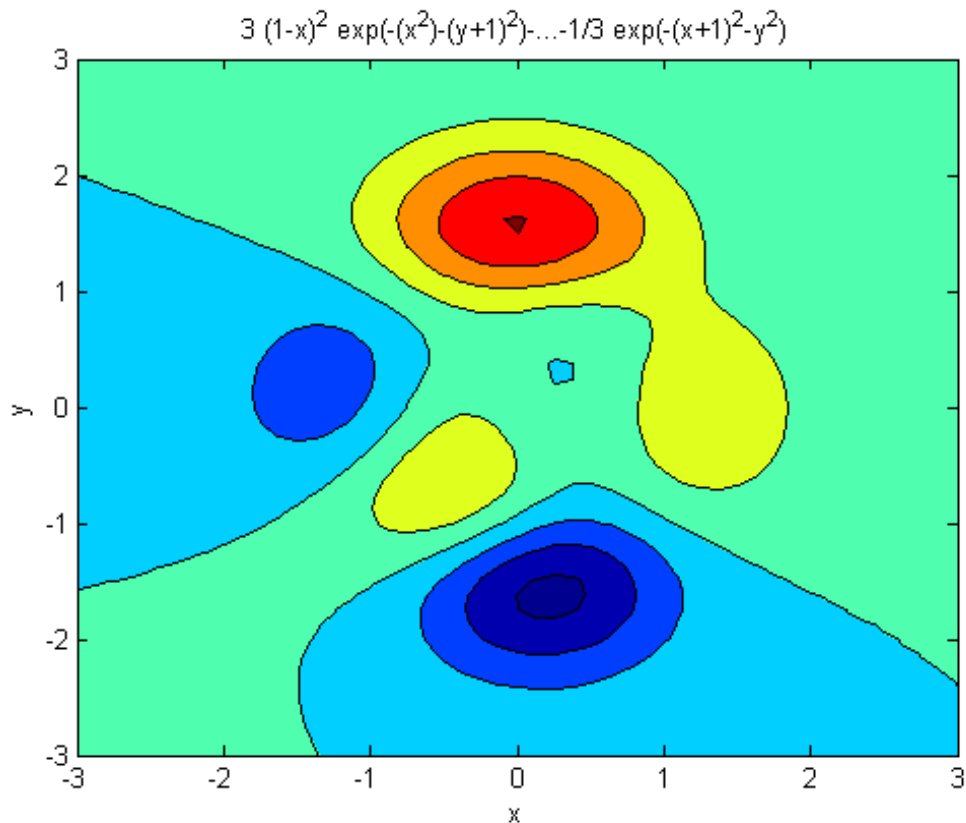

In this particular case, the title string is too long to fit at the top of the graph so MATLAB® abbreviates the string.

## See Also

[contourf](#) | [ezcontour](#) | [ezmesh](#) | [ezmeshc](#) | [ezplot](#) | [ezplot3](#) | [ezpolar](#) | [ezsurf](#) | [ezsurfz](#) | [function\\_handle](#)

## How To

- [Anonymous Functions](#)

**Purpose** Easy-to-use 3-D mesh plotter

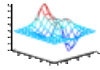

## Syntax

```
ezmesh(fun)
ezmesh(fun, domain)
ezmesh(funx, funy, funz)
ezmesh(funx, funy, funz, [smin, smax, tmin, tmax])
ezmesh(funx, funy, funz, [min, max])
ezmesh(..., n)
ezmesh(..., 'circ')
ezmesh(axes_handle, ...)
h = ezmesh(...)
```

## Description

`ezmesh(fun)` creates a graph of  $\text{fun}(x, y)$  using the mesh function. `fun` is plotted over the default domain:  $-2\pi < x < 2\pi$ ,  $-2\pi < y < 2\pi$ .

`fun` can be a function handle or a string (see the Tips section).

`ezmesh(fun, domain)` plots `fun` over the specified domain. `domain` can be either a 4-by-1 vector `[xmin, xmax, ymin, ymax]` or a 2-by-1 vector `[min, max]` (where  $\text{min} < x < \text{max}$ ,  $\text{min} < y < \text{max}$ ).

`ezmesh(funx, funy, funz)` plots the parametric surface  $\text{funx}(s, t)$ ,  $\text{funy}(s, t)$ , and  $\text{funz}(s, t)$  over the square:  $-2\pi < s < 2\pi$ ,  $-2\pi < t < 2\pi$ .

`ezmesh(funx, funy, funz, [smin, smax, tmin, tmax])` or `ezmesh(funx, funy, funz, [min, max])` plots the parametric surface using the specified domain.

`ezmesh(..., n)` plots `fun` over the default domain using an  $n$ -by- $n$  grid. The default value for  $n$  is 60.

`ezmesh(..., 'circ')` plots `fun` over a disk centered on the domain.

`ezmesh(axes_handle, ...)` plots into the axes with handle `axes_handle` instead of the current axes (`gca`).

`h = ezmesh(...)` returns the handle to a surface object in `h`.

## Tips

### Passing the Function as a String

Array multiplication, division, and exponentiation are always implied in the string expression you pass to `ezmesh`. For example, the MATLAB syntax for a mesh plot of the expression

```
sqrt(x.^2 + y.^2);
```

is written as

```
ezmesh('sqrt(x^2 + y^2)')
```

That is,  $x^2$  is interpreted as  $x.^2$  in the string you pass to `ezmesh`.

If the function to be plotted is a function of the variables  $u$  and  $v$  (rather than  $x$  and  $y$ ), then the domain endpoints `umin`, `umax`, `vmin`, and `vmax` are sorted alphabetically. Thus, `ezmesh('u^2 - v^3',[0,1],[3,6])` plots  $u^2 - v^3$  over  $0 < u < 1$ ,  $3 < v < 6$ .

### Passing a Function Handle

Function handle arguments must point to functions that use MATLAB syntax. For example, the following statements define an anonymous function and pass the function handle `fh` to `ezmesh`.

```
fh = @(x,y) sqrt(x.^2 + y.^2);
ezmesh(fh)
```

Note that when using function handles, you must use the array power, array multiplication, and array division operators (`.^`, `.*`, `./`) since `ezmesh` does not alter the syntax, as in the case with string inputs.

### Passing Additional Arguments

If your function has additional parameters, for example `k` in `myfun`:

```
function z = myfun(x,y,k)
z = x.^k - y.^k - 1;
```

then you can use an anonymous function to specify that parameter:

```
ezmesh(@(x,y)myfun(x,y,2))
```

**Examples**

This example visualizes the function

$$f(x, y) = xe^{-x^2-y^2}$$

with a mesh plot drawn on a 40-by-40 grid. The mesh lines are set to a uniform blue color by setting the colormap to a single color:

```
fh = @(x,y) x.*exp(-x.^2-y.^2);
ezmesh(fh,40)
colormap([0 0 1])
```

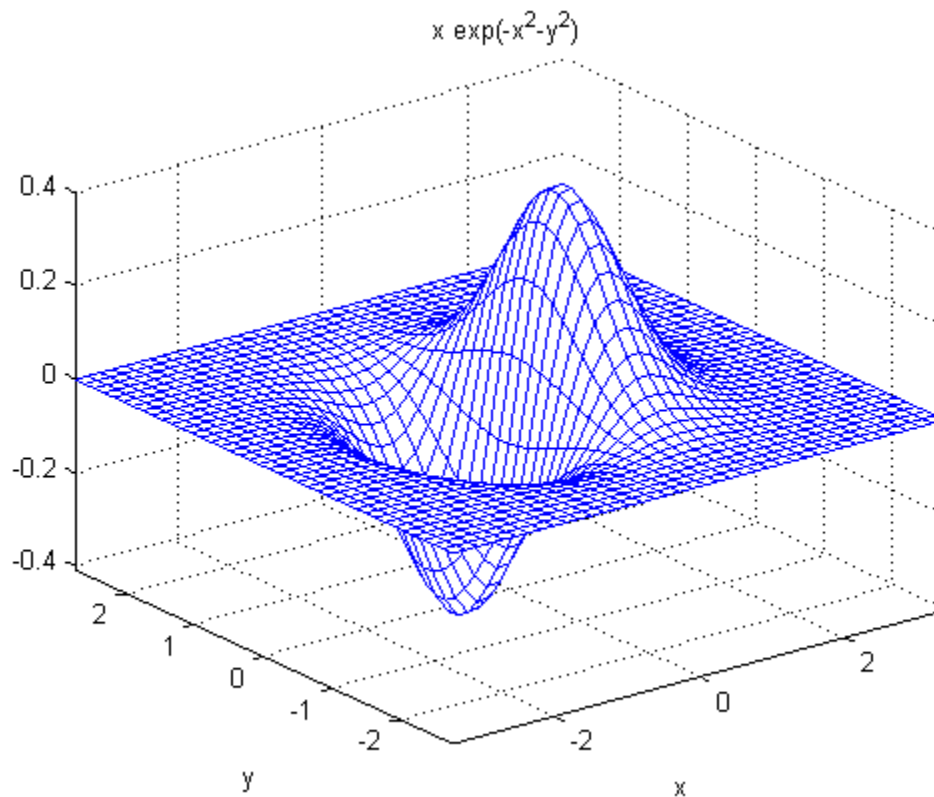

# ezmesh

---

## See Also

[ezmeshc](#) | [function\\_handle](#) | [mesh](#)

## How To

- [Anonymous Functions](#)

**Purpose**

Easy-to-use combination mesh/contour plotter

**Syntax**

```
ezmeshc(fun)
ezmeshc(fun,domain)
ezmeshc(funx,funy,funz)
ezmeshc(funx,funy,funz,[smin,smax,tmin,tmax])
ezmeshc(funx,funy,funz,[min,max])
ezmeshc(...,n)
ezmeshc(...,'circ')
ezmesh(axes_handle,...)
h = ezmeshc(...)
```

**Description**

`ezmeshc(fun)` creates a graph of `fun(x,y)` using the `meshc` function. `fun` is plotted over the default domain  $-2\pi < x < 2\pi$ ,  $-2\pi < y < 2\pi$ .

`fun` can be a function handle or a string (see the Tips section).

`ezmeshc(fun,domain)` plots `fun` over the specified domain. `domain` can be either a 4-by-1 vector `[xmin, xmax, ymin, ymax]` or a 2-by-1 vector `[min, max]` (where  $\min < x < \max$ ,  $\min < y < \max$ ).

`ezmeshc(funx,funy,funz)` plots the parametric surface `funx(s,t)`, `funy(s,t)`, and `funz(s,t)` over the square:  $-2\pi < s < 2\pi$ ,  $-2\pi < t < 2\pi$ .

`ezmeshc(funx,funy,funz,[smin,smax,tmin,tmax])` or `ezmeshc(funx,funy,funz,[min,max])` plots the parametric surface using the specified domain.

`ezmeshc(...,n)` plots `fun` over the default domain using an `n`-by-`n` grid. The default value for `n` is 60.

`ezmeshc(...,'circ')` plots `fun` over a disk centered on the domain.

`ezmesh(axes_handle,...)` plots into the axes with handle `axes_handle` instead of the current axes (`gca`).

`h = ezmeshc(...)` returns the handle to a surface object in `h`.

## Tips

### Passing the Function as a String

Array multiplication, division, and exponentiation are always implied in the string expression you pass to `ezmeshc`. For example, the MATLAB syntax for a mesh/contour plot of the expression

```
sqrt(x.^2 + y.^2);
```

is written as

```
ezmeshc('sqrt(x^2 + y^2)')
```

That is,  $x^2$  is interpreted as  $x.^2$  in the string you pass to `ezmeshc`.

If the function to be plotted is a function of the variables  $u$  and  $v$  (rather than  $x$  and  $y$ ), then the domain endpoints `umin`, `umax`, `vmin`, and `vmax` are sorted alphabetically. Thus, `ezmeshc('u^2 - v^3',[0,1],[3,6])` plots  $u^2 - v^3$  over  $0 < u < 1$ ,  $3 < v < 6$ .

### Passing a Function Handle

Function handle arguments must point to functions that use MATLAB syntax. For example, the following statements define an anonymous function and pass the function handle `fh` to `ezmeshc`.

```
fh = @(x,y) sqrt(x.^2 + y.^2);
ezmeshc(fh)
```

Note that when using function handles, you must use the array power, array multiplication, and array division operators (`.^`, `.*`, `./`) since `ezmeshc` does not alter the syntax, as in the case with string inputs.

### Passing Additional Arguments

If your function has additional parameters, for example `k` in `myfun`:

```
function z = myfun(x,y,k)
z = x.^k - y.^k - 1;
```

then you can use an anonymous function to specify that parameter:

```
ezmeshc(@(x,y)myfun(x,y,2))
```



**Examples**

Create a mesh/contour graph of the expression

$$f(x,y) = \frac{y}{1+x^2+y^2}$$

over the domain  $-5 < x < 5$ ,  $-2\pi < y < 2\pi$ :

```
ezmeshc('y/(1 + x^2 + y^2)', [-5,5, -2*pi,2*pi])
view(-65.5,26)
```

Use the mouse to rotate the axes to better observe the contour lines  
(this picture uses a view of azimuth = -65.5 and elevation = 26)

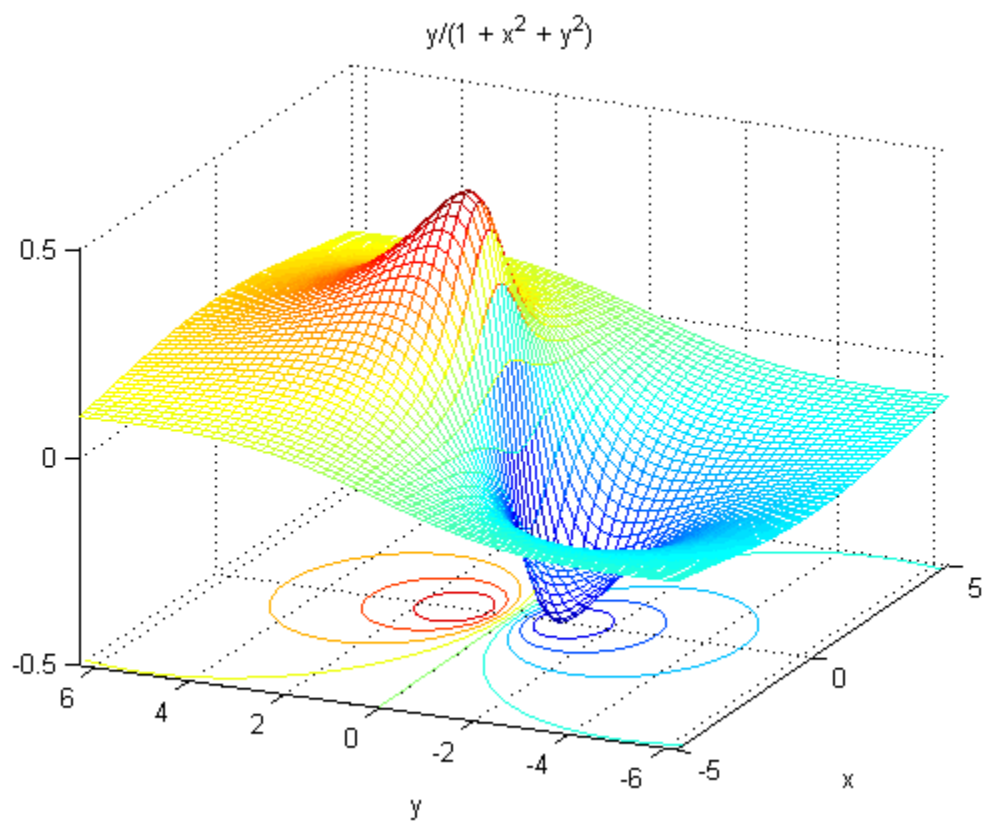

## See Also

[ezmesh](#) | [ezsurf](#) | [function\\_handle](#) | [meshc](#)

## How To

- [Anonymous Functions](#)

**Purpose** Easy-to-use function plotter

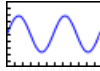

**Syntax**

```
ezplot(fun)
ezplot(fun, [xmin,xmax])
ezplot(fun2)
ezplot(fun2, [xymin,xymax])
ezplot(fun2, [xmin,xmax,ymin,ymax])
ezplot(funx,funy)
ezplot(funx,funy, [tmin,tmax])
ezplot(...,figure_handle)
ezplot(axes_handle,...)
h = ezplot(...)
```

**Description** `ezplot(fun)` plots the expression  $\text{fun}(x)$  over the default domain  $-2\pi < x < 2\pi$ , where  $\text{fun}(x)$  is an explicit function of only  $x$ .

`fun` can be a function handle or a string.

`ezplot(fun, [xmin,xmax])` plots  $\text{fun}(x)$  over the domain:  $x_{\min} < x < x_{\max}$ .

For an implicit function,  $\text{fun2}(x,y)$ :

`ezplot(fun2)` plots  $\text{fun2}(x,y) = 0$  over the default domain  $-2\pi < x < 2\pi$ ,  $-2\pi < y < 2\pi$ .

`ezplot(fun2, [xymin,xymax])` plots  $\text{fun2}(x,y) = 0$  over  $x_{\min} < x < x_{\max}$  and  $y_{\min} < y < y_{\max}$ .

`ezplot(fun2, [xmin,xmax,ymin,ymax])` plots  $\text{fun2}(x,y) = 0$  over  $x_{\min} < x < x_{\max}$  and  $y_{\min} < y < y_{\max}$ .

`ezplot(funx,funy)` plots the parametrically defined planar curve  $\text{funx}(t)$  and  $\text{funy}(t)$  over the default domain  $0 < t < 2\pi$ .

`ezplot(funx,funy, [tmin,tmax])` plots  $\text{funx}(t)$  and  $\text{funy}(t)$  over  $t_{\min} < t < t_{\max}$ .

`ezplot(..., figure_handle)` plots the given function over the specified domain in the figure window identified by the handle `figure`.

`ezplot(axes_handle, ...)` plots into the axes with handle `axes_handle` instead of the current axes (`gca`).

`h = ezplot(...)` returns the handle to all the plot objects in `h`.

## Tips

### Passing the Function as a String

Array multiplication, division, and exponentiation are always implied in the expression you pass to `ezplot`. For example, the MATLAB syntax for a plot of the expression

```
x.^2 - y.^2
```

which represents an implicitly defined function, is written as

```
ezplot('x^2 - y^2')
```

That is, `x^2` is interpreted as `x.^2` in the string you pass to `ezplot`.

### Passing a Function Handle

Function handle arguments must point to functions that use MATLAB syntax. For example, the following statements define an anonymous function and pass the function handle `fh` to `ezplot`,

```
fh = @(x,y) sqrt(x.^2 + y.^2 - 1);
ezplot(fh)
axis equal
```

which plots a circle. Note that when using function handles, you must use the array power, array multiplication, and array division operators (`.^`, `.*`, `./`) since `ezplot` does not alter the syntax, as in the case with string inputs.

### Passing Additional Arguments

If your function has additional parameters, for example `k` in `myfun`:

```
function z = myfun(x,y,k)
```

```
z = x.^k - y.^k - 1;
```

then you can use an anonymous function to specify that parameter:

```
ezplot(@(x,y)myfun(x,y,2))
```

### Controlling Line Color

ezplot colors lines according to the type of graphics object it chooses to plot the input function.

- For an implicit function, ezplot uses a `LineSeries` object to generate the graph. To change the color, you should set the `Color` property.
- For an explicit function, the graph generated is a `Hgroup` object. So, to change the color, you should set the `LineColor` property.

### Example

#### Plot an Explicit Function

Plot the explicit function  $x^2$  over the domain  $[-2\pi, 2\pi]$ .

```
ezplot('x^2')
```

# ezplot

---

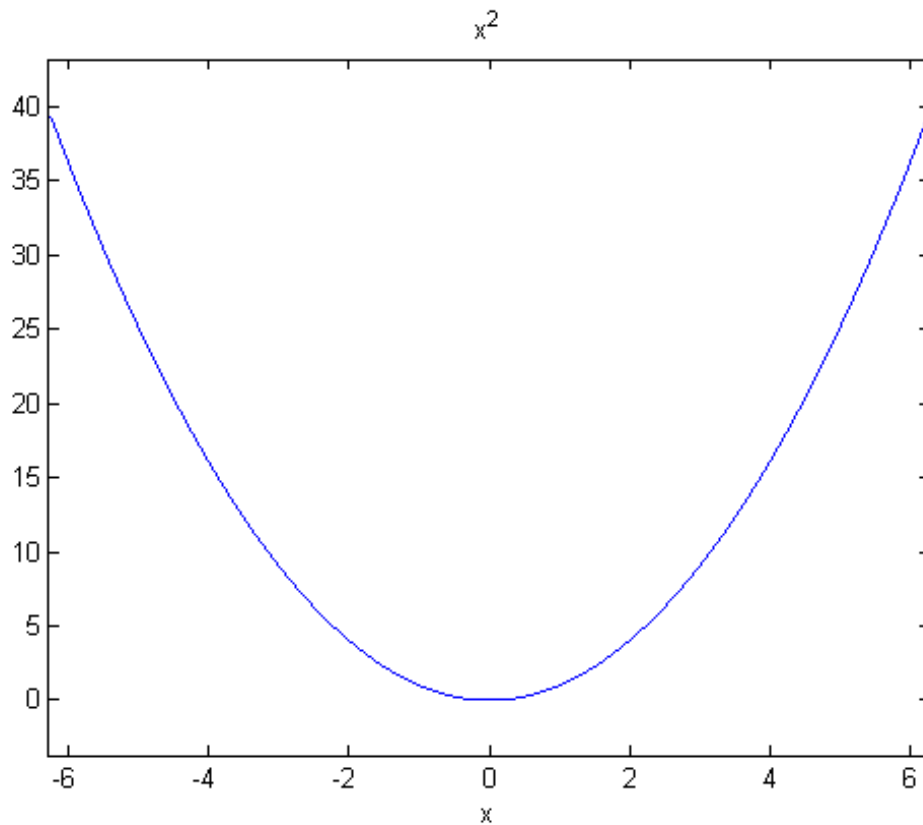

The default domain is  $[-2\pi, 2\pi]$ .

## Plot an Implicit Function

Plot the implicitly defined function  $x^2 - y^4 = 0$  over the domain  $[-2\pi, 2\pi]$ .

```
ezplot('x^2-y^4')
```

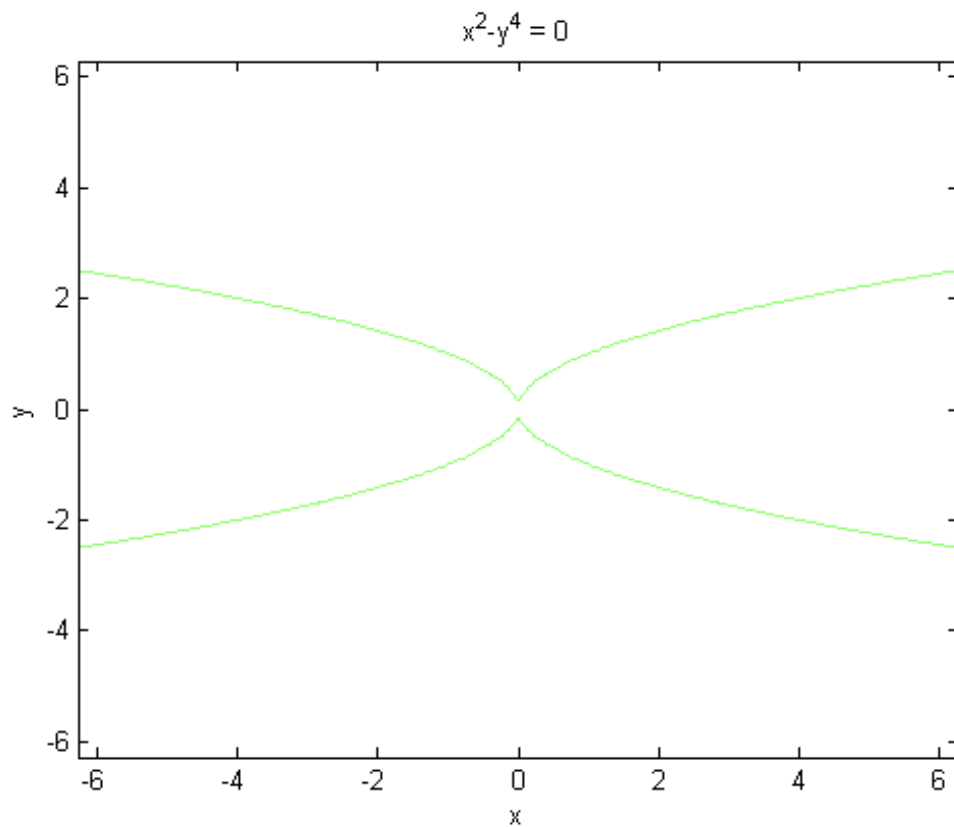

The default domain is  $[-2\pi, 2\pi]$ .

**See Also**

[ezplot3](#) | [ezpolar](#) | [function\\_handle](#) | [plot](#)

**How To**

- [Anonymous Functions](#)

# ezplot3

---

**Purpose** Easy-to-use 3-D parametric curve plotter



**Syntax**

```
ezplot3(funx,funy,funz)
ezplot3(funx,funy,funz,[tmin,tmax])
ezplot3(...,'animate')
ezplot3(axes_handle,...)
h = ezplot3(...)
```

**Description** `ezplot3(funx,funy,funz)` plots the spatial curve  $\text{funx}(t)$ ,  $\text{funy}(t)$ , and  $\text{funz}(t)$  over the default domain  $0 < t < 2\pi$ .

`funx`, `funy`, and `funz` can be function handles or strings (see the Tips section).

`ezplot3(funx,funy,funz,[tmin,tmax])` plots the curve  $\text{funx}(t)$ ,  $\text{funy}(t)$ , and  $\text{funz}(t)$  over the domain  $t_{\min} < t < t_{\max}$ .

`ezplot3(...,'animate')` produces an animated trace of the spatial curve.

`ezplot3(axes_handle,...)` plots into the axes with handle `axes_handle` instead of the current axes (`gca`).

`h = ezplot3(...)` returns the handle to the plotted objects in `h`.

**Tips** **Passing the Function as a String**

Array multiplication, division, and exponentiation are always implied in the expression you pass to `ezplot3`. For example, the MATLAB syntax for a plot of the expression

```
x = s./2, y = 2.*s, z = s.^2;
```

which represents a parametric function, is written as

```
ezplot3('s/2','2*s','s^2')
```



That is,  $s/2$  is interpreted as `s./2` in the string you pass to `ezplot3`.

### Passing a Function Handle

Function handle arguments must point to functions that use MATLAB syntax. For example, the following statements define an anonymous function and pass the function handle `fh` to `ezplot3`.

```
fh1 = @(s) s./2; fh2 = @(s) 2.*s; fh3 = @(s) s.^2;
ezplot3(fh1,fh2,fh3)
```

Note that when using function handles, you must use the array power, array multiplication, and array division operators (`.^`, `.*`, `./`) since `ezplot3` does not alter the syntax, as in the case with string inputs.

### Passing Additional Arguments

If your function has additional parameters, for example `k` in `myfunkt`:

```
function s = myfunkt(t,k)
s = t.^k.*sin(t);
```

then you can use an anonymous function to specify that parameter:

```
ezplot3(@cos,@(t)myfunkt(t,1),@sqrt)
```

## Examples

### Plot a Parametric Curve

Plot this parametric curve over the domain  $[0, 6\pi]$ .

$$x = \sin(t), \quad y = \cos(t), \quad z = t$$

```
ezplot3('sin(t)', 'cos(t)', 't', [0,6*pi])
```

# ezplot3

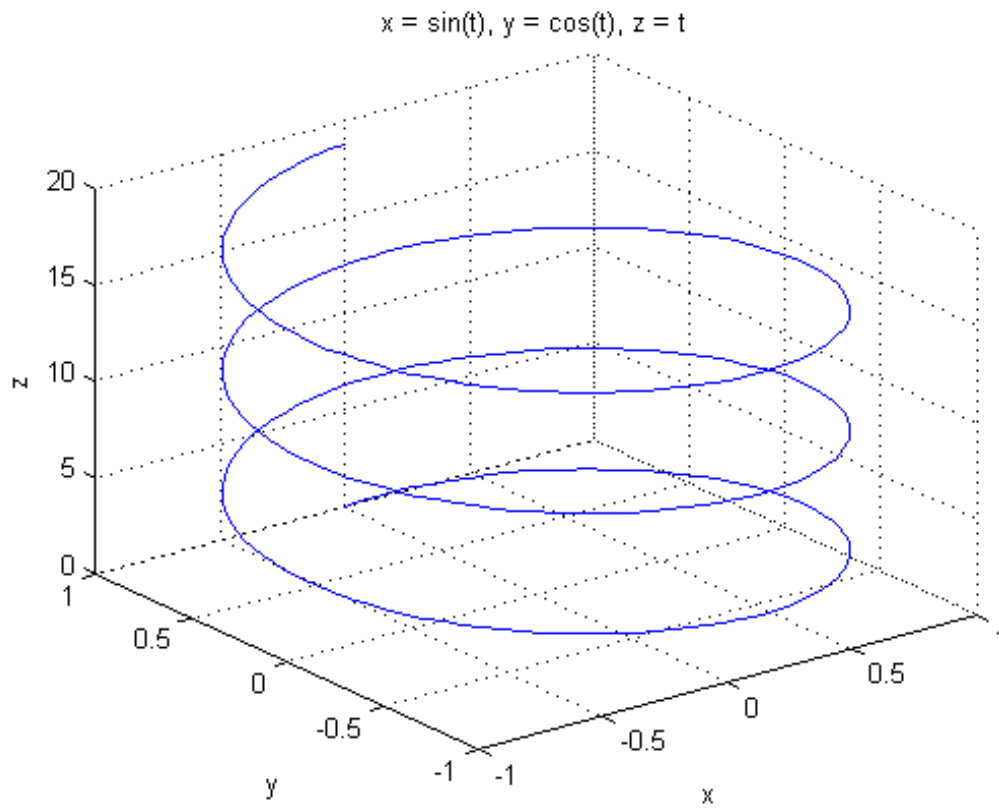

## See Also

[ezplot](#) | [ezpolar](#) | [function\\_handle](#) | [plot3](#)

## How To

- [Anonymous Functions](#)

**Purpose**

Easy-to-use polar coordinate plotter

**Syntax**

```
ezpolar(fun)
ezpolar(fun,[a,b])
ezpolar(axes_handle,...)
h = ezpolar(...)
```

**Description**

`ezpolar(fun)` plots the polar curve  $\rho = \text{fun}(\theta)$  over the default domain  $0 < \theta < 2\pi$ .

`fun` can be a function handle or a string (see the Tips section).

`ezpolar(fun,[a,b])` plots `fun` for  $a < \theta < b$ .

`ezpolar(axes_handle,...)` plots into the axes with handle `axes_handle` instead of the current axes (`gca`).

`h = ezpolar(...)` returns the handle to a line object in `h`.

**Tips****Passing the Function as a String**

Array multiplication, division, and exponentiation are always implied in the expression you pass to `ezpolar`. For example, the MATLAB syntax for a plot of the expression

```
t.^2.*cos(t)
```

which represents an implicitly defined function, is written as

```
ezpolar('t^2*cos(t)')
```

That is, `t^2` is interpreted as `t.^2` in the string you pass to `ezpolar`.

## Passing a Function Handle

Function handle arguments must point to functions that use MATLAB syntax. For example, the following statements define an anonymous function and pass the function handle `fh` to `ezpolar`.

```
fh = @(t) t.^2.*cos(t);
ezpolar(fh)
```

Note that when using function handles, you must use the array power, array multiplication, and array division operators (`.^`, `.*`, `./`) since `ezpolar` does not alter the syntax, as in the case with string inputs.

## Passing Additional Arguments

If your function has additional parameters, for example `k1` and `k2` in `myfun`:

```
function s = myfun(t,k1,k2)
s = sin(k1*t).*cos(k2*t);
```

then you can use an anonymous function to specify the parameters:

```
ezpolar(@(t)myfun(t,2,3))
```

## Examples

### Polar Plot of Mathematical Function

Plot the function  $1 + \cos(t)$  over the domain  $[0, 2\pi]$ .

```
figure
ezpolar('1+cos(t)')
```

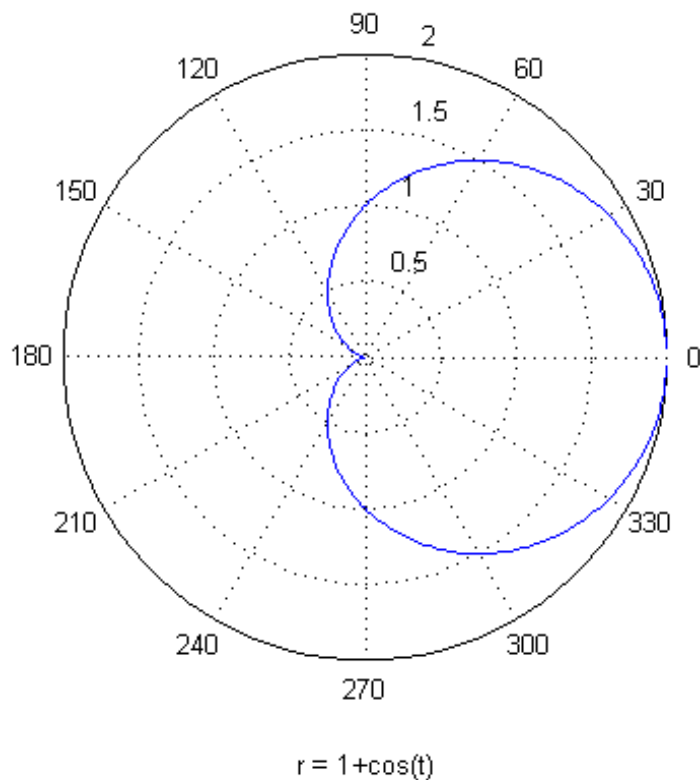
**See Also**

[ezplot](#) | [ezplot3](#) | [function\\_handle](#) | [plot](#) | [plot3](#) | [polar](#)

**How To**

- [Anonymous Functions](#)

## Purpose

Easy-to-use 3-D colored surface plotter



## Syntax

```
ezsurf(fun)
ezsurf(fun, domain)
ezsurf(funx, funy, funz)
ezsurf(funx, funy, funz, [smin, smax, tmin, tmax])
ezsurf(funx, funy, funz, [min, max])
ezsurf(..., n)
ezsurf(..., 'circ')
ezsurf(axes_handle, ...)
h = ezsurf(...)
```

## Description

`ezsurf(fun)` creates a graph of  $\text{fun}(x, y)$  using the `surf` function. `fun` is plotted over the default domain:  $-2\pi < x < 2\pi$ ,  $-2\pi < y < 2\pi$ .

`fun` can be a function handle or a string (see the Tips section).

`ezsurf(fun, domain)` plots `fun` over the specified domain. `domain` must be a vector. See the “Algorithms” on page 1-2008 section for details on vector inputs vs axes limit outputs.

`ezsurf(funx, funy, funz)` plots the parametric surface  $\text{funx}(s, t)$ ,  $\text{funy}(s, t)$ , and  $\text{funz}(s, t)$  over the square:  $-2\pi < s < 2\pi$ ,  $-2\pi < t < 2\pi$ .

`ezsurf(funx, funy, funz, [smin, smax, tmin, tmax])` or `ezsurf(funx, funy, funz, [min, max])` plots the parametric surface using the specified domain.

`ezsurf(..., n)` plots `fun` over the default domain using an  $n$ -by- $n$  grid. The default value for  $n$  is 60.

`ezsurf(..., 'circ')` plots `fun` over a disk centered on the domain.

`ezsurf(axes_handle, ...)` plots into the axes with handle `axes_handle` instead of the current axes (`gca`).

`h = ezsurf(...)` returns the handle to a surface object in `h`.

## Tips

ezsurf and ezsurfz do not accept complex inputs.

### Passing the Function as a String

Array multiplication, division, and exponentiation are always implied in the expression you pass to ezsurf. For example, the MATLAB syntax for a surface plot of the expression

```
sqrt(x.^2 + y.^2);
```

is written as

```
ezsurf('sqrt(x^2 + y^2)')
```

That is,  $x^2$  is interpreted as  $x.^2$  in the string you pass to ezsurf.

If the function to be plotted is a function of the variables  $u$  and  $v$  (rather than  $x$  and  $y$ ), then the domain endpoints  $u_{\min}$ ,  $u_{\max}$ ,  $v_{\min}$ , and  $v_{\max}$  are sorted alphabetically. Thus, `ezsurf('u^2 - v^3', [0,1], [3,6])` plots  $u^2 - v^3$  over  $0 < u < 1$ ,  $3 < v < 6$ .

### Passing a Function Handle

Function handle arguments must point to functions that use MATLAB syntax. For example, the following statements define an anonymous function and pass the function handle `fh` to ezsurf.

```
fh = @(x,y) sqrt(x.^2 + y.^2);
ezsurf(fh)
```

Note that when using function handles, you must use the array power, array multiplication, and array division operators (`.^`, `.*`, `./`) since ezsurf does not alter the syntax, as in the case with string inputs.

### Passing Additional Arguments

If your function has additional parameters, for example `k` in `myfun`:

```
function z = myfun(x,y,k1,k2,k3)
z = x.*(y.^k1)./(x.^k2 + y.^k3);
```

then you can use an anonymous function to specify that parameter:

## Examples

```
ezsurf(@(x,y)myfun(x,y,2,2,4))
```

ezsurf does not graph points where the mathematical function is not defined (these data points are set to NaNs, which do not plot). This example illustrates this filtering of singularities/discontinuous points by graphing the function

$$f(x, y) = \text{real}(a \tan(x + iy))$$

over the default domain  $-2\pi < x < 2\pi$ ,  $-2\pi < y < 2\pi$ :

```
ezsurf('real(atan(x+i*y))')
```



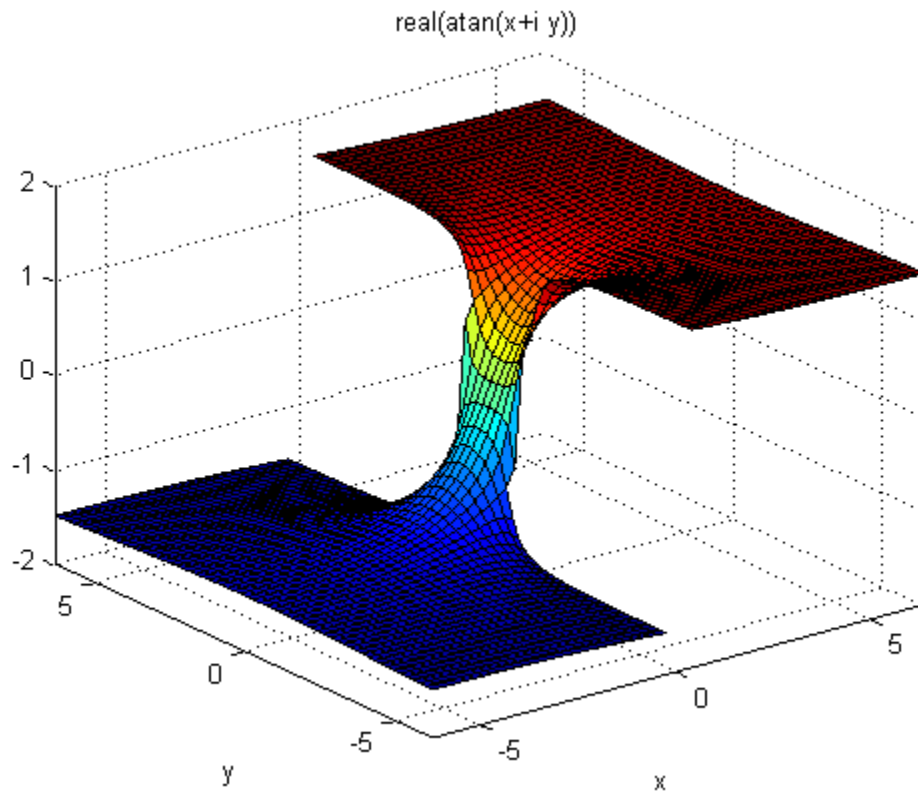

Using surf to plot the same data produces a graph without filtering of discontinuities (as well as requiring more steps):

```
[x,y] = meshgrid(linspace(-2*pi,2*pi,60));
z = real(atan(x+1i.*y));
surf(x,y,z)
```

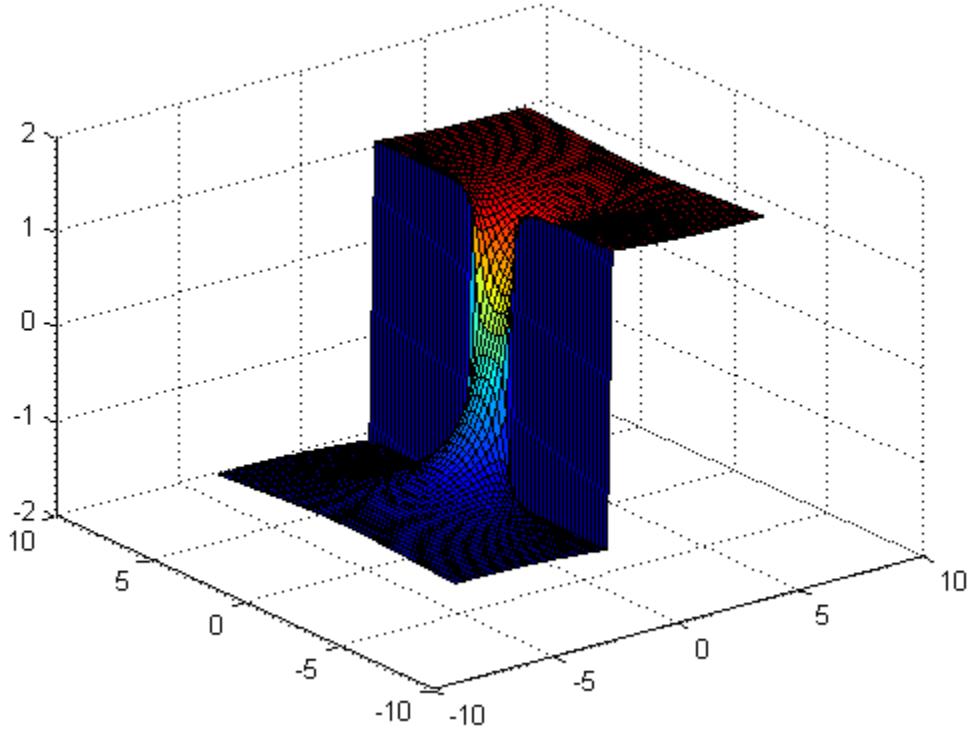

Note also that `ezsurf` creates graphs that have axis labels, a title, and extend to the axis limits.

## Algorithms

`ezsurf` determines the  $x$ - and  $y$ -axis limits in different ways depending on how you input the domain (if at all). In the following table,  $R$  is the vector  $[x_{\min}, x_{\max}, y_{\min}, y_{\max}]$  and  $v$  is the manually entered domain vector.

| Number of domain values specified:                      | Resulting domain vector:                                                 |
|---------------------------------------------------------|--------------------------------------------------------------------------|
| <code>v = [ ];</code>                                   | <code>R = [-2*pi, 2*pi, -2*pi, 2*pi];</code>                             |
| <code>v = [ v(1) ];</code>                              | <code>R = double([-abs(v),abs(v),-abs(v),abs(v)]);</code>                |
| <code>v = [ v(1) v(2) ];</code>                         | <code>R = double([v(1),v(2),v(1),v(2)]);</code>                          |
| <code>v = [ v(1) v(2) v(3) ];</code>                    | <code>R = double([-v(1),v(2),-abs(v(3)),abs(v(3))]);</code>              |
| <code>v = [ v(1) v(2) v(3) v(4) ];</code>               | <code>R = double(v);</code>                                              |
| <code>v = [ v(1)..v(n) ];</code><br><code>n&gt;4</code> | <code>R = double([-abs(v(1)), abs(v(1)), -abs(v(1)), abs(v(1))]);</code> |

If you specify a single number in non-vector format (without square brackets, [ ]), ezsurf interprets it as the n, the number of points desired between the axes max and min values.

By default, ezsurf uses 60 points between the max and min values of an axes. When the min and max values are the default values (R = [-2\*pi, 2\*pi, -2\*pi, 2\*pi]); ezsurf ensures the 60 points fall within the non-complex range of the specified equation. For example,

$\sqrt{1-x^2-y^2}$  is only real when  $x^2-y^2 \leq 1$ . The default graph of this function looks like this:

```
ezsurf('sqrt(1-x^2-y^2)')
```

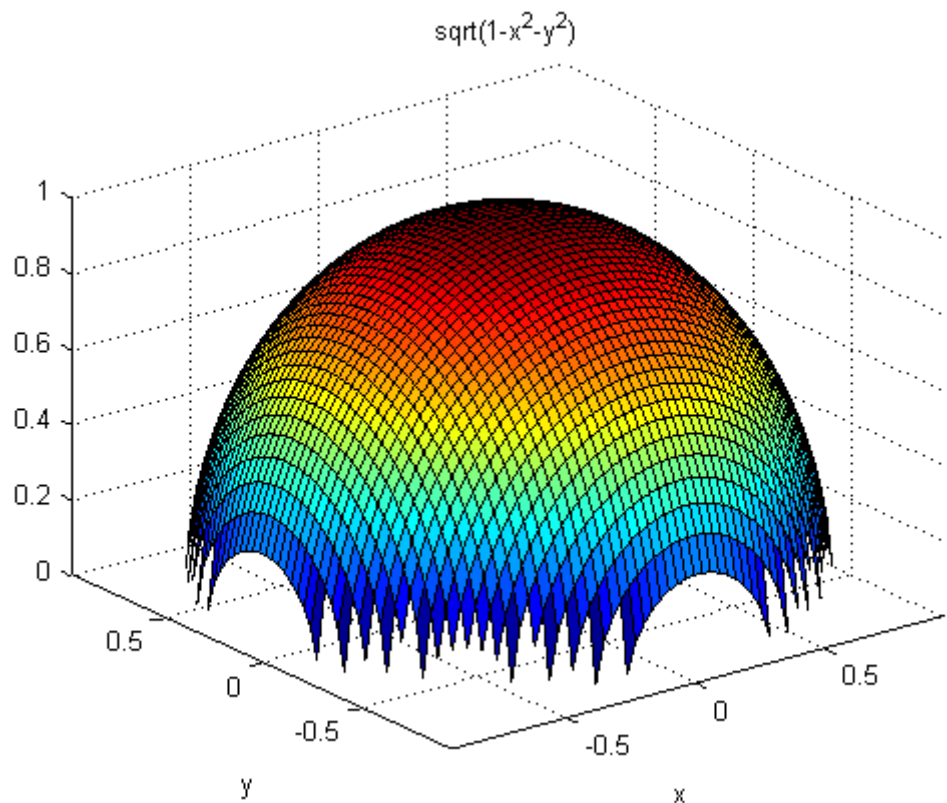

You can see that there are 60 points between the minimum and maximum values for which  $\sqrt{1-x^2-y^2}$  has real values. However, when you specify the domain values to be the same as the default ( $R = [-2*\pi, 2*\pi, -2*\pi, 2*\pi]$ ), a different result appears:

```
ezsurf('sqrt(1-x^2-y^2)',[-2*pi 2*pi])
```

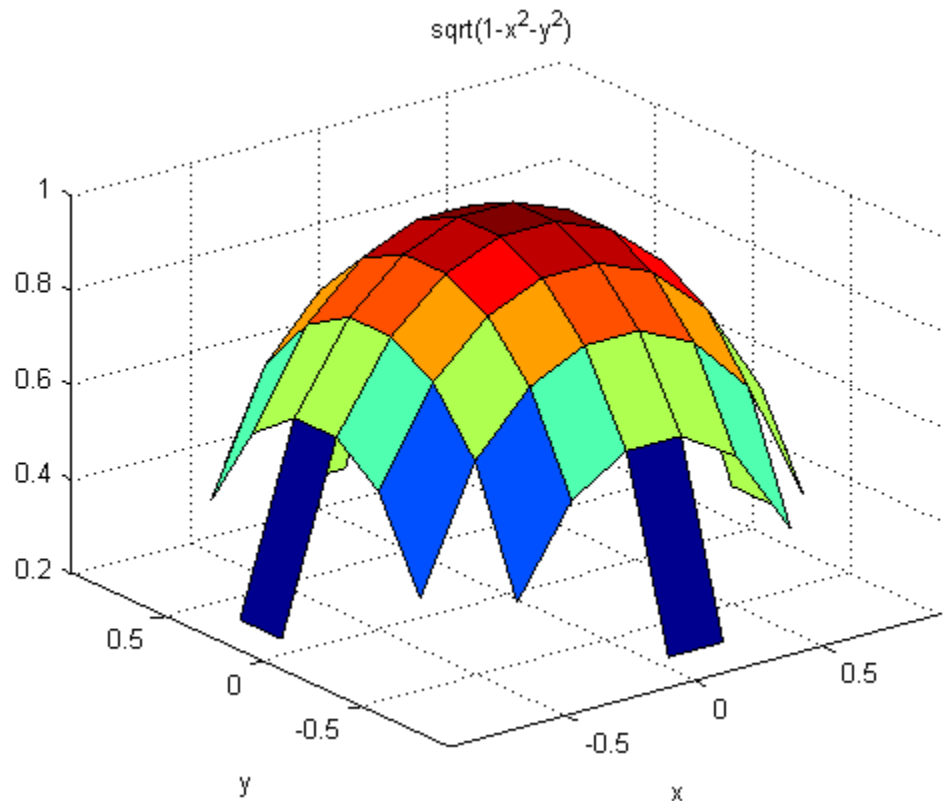

In this case, the graphic limits are the same, but ezsurf used 60 points between the user-defined limits instead of checking to see if all those points would have real answers.

## See Also

[ezmesh](#) | [ezsurf](#) | [function\\_handle](#) | [surf](#)

## How To

- [Anonymous Functions](#)

## Purpose

Easy-to-use combination surface/contour plotter

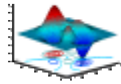

## Syntax

```
ezsurf(fun)
ezsurf(fun, domain)
ezsurf(funx, funy, funz)
ezsurf(funx, funy, funz, [smin, smax, tmin, tmax])
ezsurf(funx, funy, funz, [min, max])
ezsurf(..., n)
ezsurf(..., 'circ')
ezsurf(axes_handle, ...)
h = ezsurf(...)
```

## Description

`ezsurf(fun)` creates a graph of  $fun(x, y)$  using the `surf` function. The function `fun` is plotted over the default domain:  $-2\pi < x < 2\pi$ ,  $-2\pi < y < 2\pi$ .

`fun` can be a function handle or a string (see the Tips section).

`ezsurf(fun, domain)` plots `fun` over the specified domain. `domain` can be either a 4-by-1 vector `[xmin, xmax, ymin, ymax]` or a 2-by-1 vector `[min, max]` (where  $\min < x < \max$ ,  $\min < y < \max$ ).

`ezsurf(funx, funy, funz)` plots the parametric surface  $funx(s, t)$ ,  $funy(s, t)$ , and  $funz(s, t)$  over the square:  $-2\pi < s < 2\pi$ ,  $-2\pi < t < 2\pi$ .

`ezsurf(funx, funy, funz, [smin, smax, tmin, tmax])` or `ezsurf(funx, funy, funz, [min, max])` plots the parametric surface using the specified domain.

`ezsurf(..., n)` plots  $f$  over the default domain using an  $n$ -by- $n$  grid. The default value for  $n$  is 60.

`ezsurf(..., 'circ')` plots  $f$  over a disk centered on the domain.

`ezsurf(axes_handle, ...)` plots into the axes with handle `axes_handle` instead of the current axes (`gca`).

`h = ezsurf(...)` returns the handles to the graphics objects in `h`.

## Tips

`ezsurf` and `ezsurf` do not accept complex inputs.

### Passing the Function as a String

Array multiplication, division, and exponentiation are always implied in the expression you pass to `ezsurf`. For example, the MATLAB syntax for a surface/contour plot of the expression

```
sqrt(x.^2 + y.^2);
```

is written as

```
ezsurf('sqrt(x^2 + y^2)')
```

That is, `x^2` is interpreted as `x.^2` in the string you pass to `ezsurf`.

If the function to be plotted is a function of the variables  $u$  and  $v$  (rather than  $x$  and  $y$ ), then the domain endpoints `umin`, `umax`, `vmin`, and `vmax` are sorted alphabetically. Thus, `ezsurf('u^2 - v^3', [0,1], [3,6])` plots  $u^2 - v^3$  over  $0 < u < 1$ ,  $3 < v < 6$ .

### Passing a Function Handle

Function handle arguments must point to functions that use MATLAB syntax. For example, the following statements define an anonymous function and pass the function handle `fh` to `ezsurf`.

```
fh = @(x,y) sqrt(x.^2 + y.^2);
ezsurf(fh)
```

Note that when using function handles, you must use the array power, array multiplication, and array division operators (`.^`, `.*`, `./`) since `ezsurf` does not alter the syntax, as in the case with string inputs.

### Passing Additional Arguments

If your function has additional parameters, for example `k` in `myfun`:

```
function z = myfun(x,y,k1,k2,k3)
z = x.*(y.^k1)./(x.^k2 + y.^k3);
```

then you can use an anonymous function to specify that parameter:

```
ezsurf(@(x,y)myfun(x,y,2,2,4))
```

## Examples

Create a surface/contour plot of the expression

$$f(x,y) = \frac{y}{1+x^2+y^2}$$

over the domain  $-5 < x < 5$ ,  $-2\pi < y < 2\pi$ , with a computational grid of size 35-by-35:

```
ezsurf('y/(1 + x^2 + y^2)', [-5,5, -2*pi,2*pi], 35)
```

Put the plot in `rotate3d` mode to use the mouse to rotate the axes to better observe the contour lines (this picture uses a view of azimuth = -65.5 and elevation = 26).

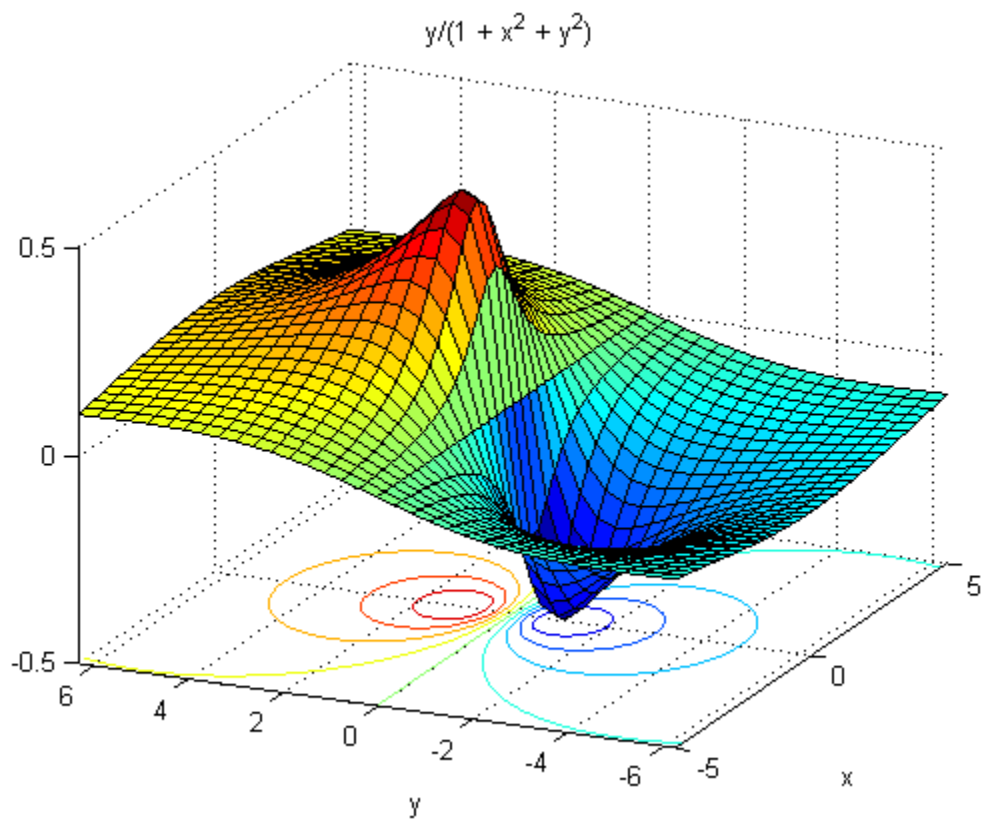

**See Also**

[ezmesh](#) | [ezmeshc](#) | [ezsurf](#) | [function\\_handle](#) | [surf](#)

**How To**

- [Anonymous Functions](#)

# TriRep.faceNormals

---

## Purpose

(Will be removed) Unit normals to specified triangles

---

**Note** `faceNormals(TriRep)` will be removed in a future release. Use `faceNormal(triangulation)` instead.

`TriRep` will be removed in a future release. Use `triangulation` instead.

---

## Syntax

`FN = faceNormals(TR, TI)`

## Description

`FN = faceNormals(TR, TI)` returns the unit normal vector to each of the specified triangles `TI`.

---

**Note** This query is only applicable to triangular surface meshes.

---

## Input Arguments

`TR`                      Triangulation representation.  
`TI`                      Column vector of indices that index into the triangulation matrix `TR.Triangulation`.

## Output Arguments

`FN`                      m-by-3 matrix. `m = length(TI)`, the number of triangles to be queried. Each row `FN(i, :)` represents the unit normal vector to triangle `TI(i)`.  
  
If `TI` is not specified the unit normal information for the entire triangulation is returned, where the normal associated with triangle `i` is the `i`'th row of `FN`.

## Examples

Triangulate a sample of random points on the surface of a sphere and use the `TriRep` to compute the normal to each triangle:

```
numpts = 100;
```

```
theta = rand(numpts,1)*2*pi;
phi = rand(numpts,1)*pi;
x = cos(theta).*sin(phi);
y = sin(theta).*sin(phi);
z = cos(phi);
dt = DelaunayTri(x,y,z);
[tri Xb] = freeBoundary(dt);
tr = TriRep(tri, Xb);
P = incenters(tr);
fn = faceNormals(tr);
trisurf(tri,Xb(:,1),Xb(:,2),Xb(:,3), ...
 'FaceColor', 'cyan', 'faceAlpha', 0.8);
axis equal;
hold on;
```

Display the result using a quiver plot:

```
quiver3(P(:,1),P(:,2),P(:,3), ...
 fn(:,1),fn(:,2),fn(:,3),0.5, 'color','r');
hold off;
```

# TriRep.faceNormals

---

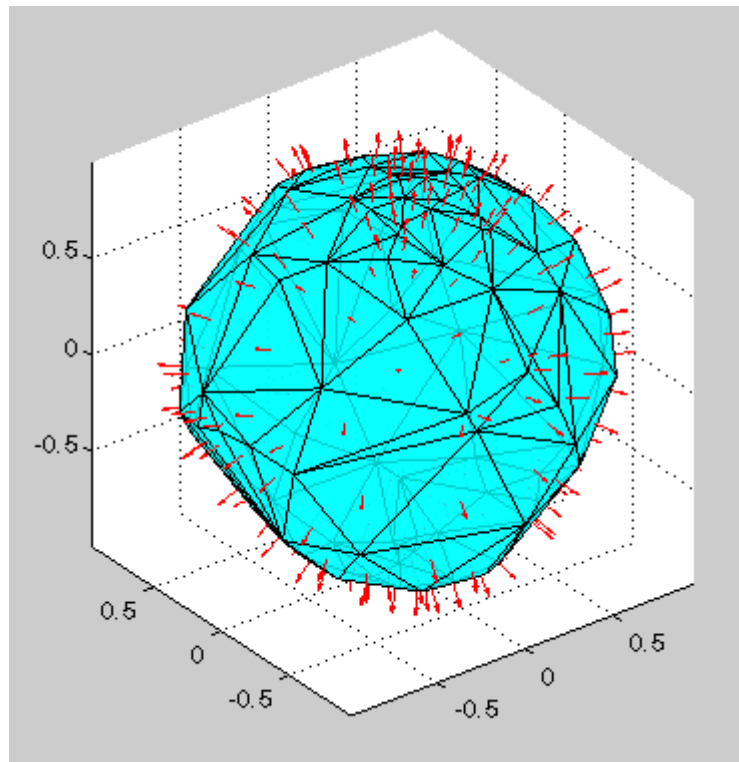

## See Also

[freeBoundary](#) | [delaunayTriangulation](#) | [triangulation](#)

|                        |                                                                                                                                                                                                                                                                                                                                                                                                                                                                                                |
|------------------------|------------------------------------------------------------------------------------------------------------------------------------------------------------------------------------------------------------------------------------------------------------------------------------------------------------------------------------------------------------------------------------------------------------------------------------------------------------------------------------------------|
| <b>Purpose</b>         | Prime factors                                                                                                                                                                                                                                                                                                                                                                                                                                                                                  |
| <b>Syntax</b>          | <code>f = factor(n)</code>                                                                                                                                                                                                                                                                                                                                                                                                                                                                     |
| <b>Description</b>     | <code>f = factor(n)</code> returns a row vector containing the prime factors of <code>n</code> . Vector <code>f</code> is of the same data type as <code>n</code> .                                                                                                                                                                                                                                                                                                                            |
| <b>Input Arguments</b> | <p><b>n - Input values</b><br/>scalar, real, nonnegative integer values</p> <p>Input values, specified as scalars that are real, nonnegative, and integer-valued.</p> <p><b>Example:</b> 10</p> <p><b>Example:</b> <code>int16(64)</code></p> <p><b>Data Types</b><br/><code>single</code>   <code>double</code>   <code>int8</code>   <code>int16</code>   <code>int32</code>   <code>int64</code>   <code>uint8</code>   <code>uint16</code>   <code>uint32</code>   <code>uint64</code></p> |
| <b>Examples</b>        | <p><b>Prime Factors of Double Integer Value</b></p> <pre>f = factor(200)  f =       2     2     2     5     5</pre> <p>Multiply the elements of <code>f</code> to reproduce the input value.</p> <pre>prod(f)  ans =       200</pre> <p><b>Prime Factors of Unsigned Integer Value</b></p> <pre>n = uint16(138);</pre>                                                                                                                                                                         |

# factor

---

```
f = factor(n)
```

```
f =
```

```
 2 3 23
```

Multiply the elements of `f` to reproduce `n`.

```
prod(f)
```

```
ans =
```

```
 138
```

## See Also

[isprime](#) | [primes](#)

|                        |                                                                                                                                                                                                                                                                                                                                                                                                                                                                                                                                                                |
|------------------------|----------------------------------------------------------------------------------------------------------------------------------------------------------------------------------------------------------------------------------------------------------------------------------------------------------------------------------------------------------------------------------------------------------------------------------------------------------------------------------------------------------------------------------------------------------------|
| <b>Purpose</b>         | Factorial of input                                                                                                                                                                                                                                                                                                                                                                                                                                                                                                                                             |
| <b>Syntax</b>          | <code>f = factorial(n)</code>                                                                                                                                                                                                                                                                                                                                                                                                                                                                                                                                  |
| <b>Description</b>     | <code>f = factorial(n)</code> returns the product of all positive integers less than or equal to <code>n</code> , where <code>n</code> is a nonnegative integer value. If <code>n</code> is an array, then <code>f</code> contains the factorial of each value of <code>n</code> . The data type and size of <code>f</code> is the same as that of <code>n</code> .                                                                                                                                                                                            |
| <b>Input Arguments</b> | <p><b>n - Input values</b><br/>scalar, vector, or array of real, nonnegative integer values</p> <p>Input values, specified as a scalar, vector, or array of real, nonnegative integers.</p> <p><b>Example:</b> 5</p> <p><b>Example:</b> [0 1 2 3 4]</p> <p><b>Example:</b> <code>int16([10 15 20])</code></p> <p><b>Data Types</b><br/><code>single</code>   <code>double</code>   <code>int8</code>   <code>int16</code>   <code>int32</code>   <code>int64</code>   <code>uint8</code>   <code>uint16</code>   <code>uint32</code>   <code>uint64</code></p> |
| <b>Examples</b>        | <p><b>10!</b></p> <pre>f = factorial(10)  f =      3628800</pre> <p><b>22!</b></p> <pre>format long f = factorial(22)  f =</pre>                                                                                                                                                                                                                                                                                                                                                                                                                               |

# factorial

---

```
1.124000727777608e+21
```

In this case, `f` is accurate up to 15 digits, `1.12400072777760e+21`, because double-precision numbers are only accurate up to 15 digits.

Reset the output format to the default.

```
format
```

## Factorial of Array Elements

```
n = [0 1 2; 3 4 5];
f = factorial(n)
```

```
f =
```

```
 1 1 2
 6 24 120
```

## Factorial of Unsigned Integer Values

```
n = uint64([5 10 15 20]);
f = factorial(n)
```

```
f =
```

```
 120 3628800 1307674368000 2432902008176640000
```

## Limitations

- For double-precision inputs, the result is exact when `n` is less than or equal to 21. Larger values of `n` produce a result that has the correct order of magnitude and is accurate for the first 15 digits. This is because double-precision numbers are only accurate up to 15 digits.
- For single-precision inputs, the result is exact when `n` is less than or equal to 13. Larger values of `n` produce a result that has the correct order of magnitude and is accurate for the first 8 digits. This is because single-precision numbers are only accurate up to 8 digits.



### Saturation

- The table below describes the saturation behavior of each data type when used with the `factorial` function. The values in the last column indicate the saturation point; that is, the first positive integer whose actual factorial is larger than the maximum representable value in the middle column. For `single` and `double`, all values larger than the maximum value are returned as `Inf`. For the integer data types, the saturation value is equal to the maximum value in the middle column.

| Data type           | Maximum Value                  | Factorial Saturation Threshold     |
|---------------------|--------------------------------|------------------------------------|
| <code>double</code> | <code>realmax</code>           | <code>factorial(171)</code>        |
| <code>single</code> | <code>realmax('single')</code> | <code>factorial(single(35))</code> |
| <code>uint64</code> | $2^{64}-1$                     | <code>factorial(uint64(21))</code> |
| <code>int64</code>  | $2^{63}-1$                     | <code>factorial(int64(21))</code>  |
| <code>uint32</code> | $2^{32}-1$                     | <code>factorial(uint32(13))</code> |
| <code>int32</code>  | $2^{31}-1$                     | <code>factorial(int32(13))</code>  |
| <code>uint16</code> | $2^{16}-1$                     | <code>factorial(uint16(9))</code>  |
| <code>int16</code>  | $2^{15}-1$                     | <code>factorial(int16(8))</code>   |
| <code>uint8</code>  | $2^8-1$                        | <code>factorial(uint8(6))</code>   |
| <code>int8</code>   | $2^7-1$                        | <code>factorial(int8(6))</code>    |

### See Also

`prod`

# false

---

**Purpose** Logical 0 (false)

**Syntax**

```
false
F = false(n)
F = false(sz)
F = false(sz1, ..., szN)
F = false(__, 'like', p)
```

**Description** `false` is shorthand for `logical(0)`.

`F = false(n)` is an n-by-n array of logical zeros.

`F = false(sz)` is an array of logical zeros where the size vector, `sz`, defines `size(F)`. For example, `false([2 3])` returns a 2-by-3 array of logical zeros.

`F = false(sz1, ..., szN)` is a `sz1`-by-...-by-`szN` array of logical zeros where `sz1, ..., szN` indicates the size of each dimension. For example, `false(2,3)` returns a 2-by-3 array of logical zeros.

`F = false( __, 'like', p)` returns an array of logical zeros of the same sparsity as the logical variable `p` using any of the previous size syntaxes.

## Input Arguments

### **n - Size of square matrix**

integer

Size of square matrix, specified as an integer. `n` sets the output array size to n-by-n. For example, `false(3)` returns a 3-by-3 array of logical zeros.

- If `n` is 0, then `F` is an empty matrix.
- If `n` is negative, then it is treated as 0.

### **Data Types**

int8 | int16 | int32 | int64 | uint8 | uint16 | uint32 | uint64

**sz - Size vector**

row vector of integers

Size vector, specified as a row vector of integers. For example, `false([2 3])` returns a 2-by-3 array of logical zeros.

- If the size of any dimension is 0, then `F` is an empty array.
- If the size of any dimension is negative, then it is treated as 0.
- If any trailing dimensions greater than 2 have a size of 1, then the output, `F`, does not include those dimensions.

**Data Types**

`int8` | `int16` | `int32` | `int64` | `uint8` | `uint16` | `uint32` | `uint64`

**sz1,...,szN - Size inputs**

comma-separated list of integers

Size inputs, specified by a comma-separated list of integers. For example, `false(2,3)` returns a 2-by-3 array of logical zeros.

- If the size of any dimension is 0, then `F` is an empty array.
- If the size of any dimension is negative, then it is treated as 0.
- If any trailing dimensions greater than 2 have a size of 1, then the output, `F`, does not include those dimensions.

**Data Types**

`int8` | `int16` | `int32` | `int64` | `uint8` | `uint16` | `uint32` | `uint64`

**p - Prototype**

logical variable

Prototype, specified as a logical variable.

**Data Types**

`single` | `double` | `int8` | `int16` | `int32` | `int64` | `uint8` | `uint16` | `uint32` | `uint64`

# false

---

## Output Arguments

### F - Output of logical zeros

scalar | vector | matrix | N-D array

Output of logical zeros, returned as a scalar, vector, matrix, or N-D array.

### Data Types

logical

## Examples

### Generate Square Matrix of Logical Zeros

Use `false` to generate a 3-by-3 square matrix of logical zeros.

```
A = false(3)
class(A)
```

```
A =
 0 0 0
 0 0 0
 0 0 0
```

```
ans =
logical
```

The result is of class `logical`.

### Generate Array of Logical Zeros with Arbitrary Dimensions

Use `false` to generate a 3-by-2-by-2 array of logical zeros.

```
false(3,2,2)
```

```
ans(:,:,1) =
 0 0
 0 0
 0 0
```

```
ans(:,:,2) =
 0 0
 0 0
 0 0
```

Alternatively, use a size vector to specify the size of the matrix.

```
false([3 2 2])
```

```
ans(:,:,1) =
 0 0
 0 0
 0 0
```

```
ans(:,:,2) =
 0 0
 0 0
 0 0
```

Note that specifying multiple vector inputs returns an error.

### Execute Logic Statement

`false` along with `true` can be used to execute logic statements.

Test the logical statement  $\sim(A \text{ and } B) \equiv (\sim A) \text{ or } (\sim B)$  for  $A =$  logical false and  $B =$  logical true.

```
~(false & true) == (~false) | (~true)
```

```
ans =
 1
```

The result is logical 1 (true), since the logical statements on both sides of the equation are equivalent. This logical statement is an instance of De Morgan's Law.

### Generate Logical Array of Selected Sparsity

Generate a logical array of the same data type and sparsity as the selected array.

```
A = logical(sparse(5,3));
whos A
F = false(4,'like',A);
```

# false

---

```
whos F
```

|      |      |       |         |            |
|------|------|-------|---------|------------|
| Name | Size | Bytes | Class   | Attributes |
| A    | 5x3  | 41    | logical | sparse     |
| Name | Size | Bytes | Class   | Attributes |
| F    | 4x4  | 49    | logical | sparse     |

The output array  $F$  has the same `sparse` attribute as the specified array  $A$ .

## Tips

- `false(n)` is much faster and more memory efficient than `logical(zeros(n))`.

## See Also

`true` | `logical`

## Concepts

- “Class Support for Array-Creation Functions”

**Purpose** Close one or all open files

**Syntax** `fclose(fileID)`  
`fclose('all')`  
`status = fclose(...)`

**Description** `fclose(fileID)` closes an open file. *fileID* is an integer file identifier obtained from `fopen`.  
`fclose('all')` closes all open files.  
`status = fclose(...)` returns a *status* of 0 when the close operation is successful. Otherwise, it returns -1.

**See Also** `ferror` | `fopen` | `frewind` | `fseek` | `ftell` | `feof` | `fscanf` | `fprintf` | `fread` | `fwrite`

# fclose (serial)

---

**Purpose** Disconnect serial port object from device

**Syntax** `fclose(obj)`

**Description** `fclose(obj)` disconnects `obj` from the device, where `obj` is a serial port object or an array of serial port objects.

**Tips** If `obj` was successfully disconnected, then the `Status` property is configured to `closed` and the `RecordStatus` property is configured to `off`. You can reconnect `obj` to the device using the `fopen` function.

An error is returned if you issue `fclose` while data is being written asynchronously. In this case, you should abort the write operation with the `stopasync` function, or wait for the write operation to complete.

**Examples** This example creates the serial port object `s` on a Windows platform, connects `s` to the device, writes and reads text data, and then disconnects `s` from the device using `fclose`.

```
s = serial('COM1');
fopen(s)
fprintf(s, '*IDN?')
idn = fscanf(s);
fclose(s)
```

At this point, the device is available to be connected to a serial port object. If you no longer need `s`, you should remove from memory with the `delete` function, and remove it from the workspace with the `clear` command.

**See Also** `clear` | `delete` | `fopen` | `stopasync` | `RecordStatus` | `Status`



**Purpose**

Plot velocity vectors

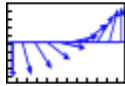
**Syntax**

```
feather(U,V)
feather(Z)
feather(...,LineStyle)
feather(axes_handle,...)
h = feather(...)
```

**Description**

A feather plot displays vectors emanating from equally spaced points along a horizontal axis. You express the vector components relative to the origin of the respective vector.

`feather(U,V)` displays the vectors specified by `U` and `V`, where `U` contains the  $x$  components as relative coordinates, and `V` contains the  $y$  components as relative coordinates.

`feather(Z)` displays the vectors specified by the complex numbers in `Z`. This is equivalent to `feather(real(Z), imag(Z))`.

`feather(...,LineStyle)` draws a feather plot using the line type, marker symbol, and color specified by `LineStyle`.

`feather(axes_handle,...)` plots into the axes with the handle `axes_handle` instead of into the current axes (`gca`).

`h = feather(...)` returns the handles to line objects in `h`.

**Examples****Create Feather Plot**

Define `theta` as values between  $-2\pi$  and  $2\pi$ . Define `r` as a vector the same size as `theta`.

```
theta = -pi/2:pi/16:pi/2;
r = 2*ones(size(theta));
```

# feather

---

Create a feather plot showing the direction of `theta`. Since `feather` uses Cartesian coordinates, convert `theta` and `r` to Cartesian coordinates using `pol2cart`.

```
[u,v] = pol2cart(theta,r);
feather(u,v);
```

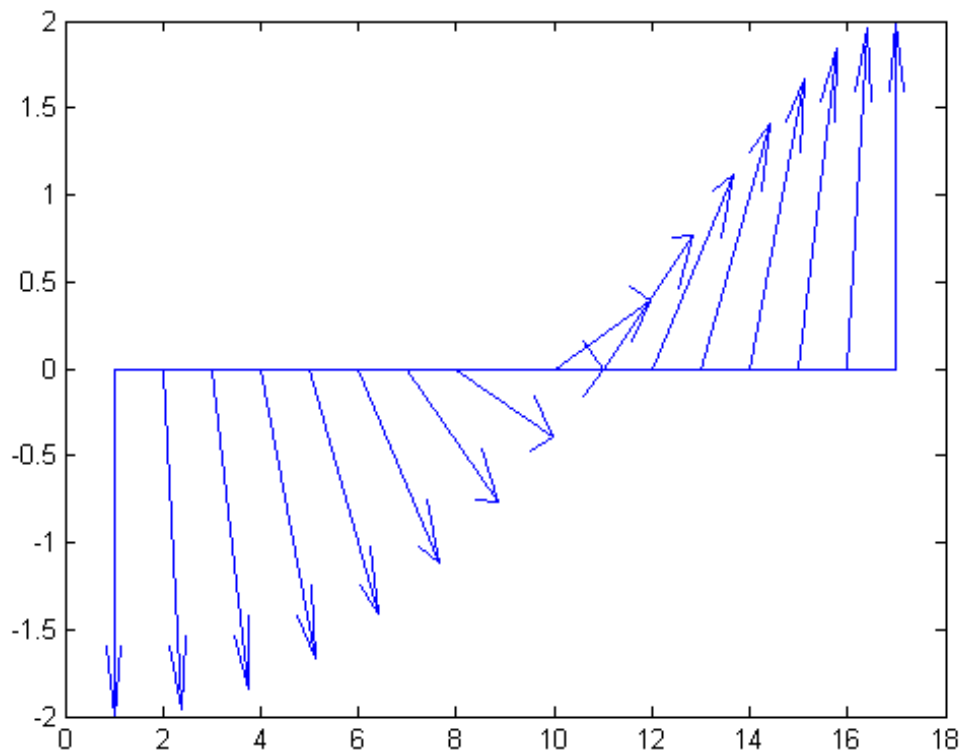

**See Also** [compass](#) | [LineSpec](#) | [rose](#)

## Purpose

(Will be removed) Sharp edges of surface triangulation

---

**Note** `featureEdges(TriRep)` will be removed in a future release. Use `featureEdges(triangulation)` instead.

---

`TriRep` will be removed in a future release. Use `triangulation` instead.

---

## Syntax

`FE = featureEdges(TR, filterangle)`

## Description

`FE = featureEdges(TR, filterangle)` returns an edge matrix `FE`. This method is typically used to extract the sharp edges in the surface mesh for the purpose of display. Edges that are shared by only one triangle and edges that are shared by more than two triangles are considered to be feature edges by default.

---

**Note** This query is only applicable to triangular surface meshes.

---

## Input Arguments

|                          |                                                                                                                                                                                                                                    |
|--------------------------|------------------------------------------------------------------------------------------------------------------------------------------------------------------------------------------------------------------------------------|
| <code>TR</code>          | Triangulation representation.                                                                                                                                                                                                      |
| <code>filterangle</code> | The threshold angle in radians. Must be in the range $(0, \pi)$ . <code>featureEdges</code> will return adjacent triangles that have a dihedral angle that deviates from $\pi$ by an angle greater than <code>filterangle</code> . |

## Output Arguments

|                 |                                                                                                                                                                                                                                                                        |
|-----------------|------------------------------------------------------------------------------------------------------------------------------------------------------------------------------------------------------------------------------------------------------------------------|
| <code>FE</code> | Edges of the triangulation. <code>FE</code> is of size <code>m-by-2</code> where <code>m</code> is the number of computed feature edges in the mesh. The vertices of the edges index into the array of points representing the vertex coordinates, <code>TR.X</code> . |
|-----------------|------------------------------------------------------------------------------------------------------------------------------------------------------------------------------------------------------------------------------------------------------------------------|

# TriRep.featureEdges

---

## Examples

Create a surface triangulation:

```
x = [0 0 0 0 0 3 3 3 3 3 3 6 6 6 6 6 9 9 9 9 9 9]';
y = [0 2 4 6 8 0 1 3 5 7 8 0 2 4 6 8 0 1 3 5 7 8]';
dt = DelaunayTri(x,y);
tri = dt(:,:);
```

Elevate the 2-D mesh to create a surface:

```
z = [0 0 0 0 0 2 2 2 2 2 2 0 0 0 0 0 0 0 0 0 0 0]';
subplot(1,2,1);
trisurf(tri,x,y,z, 'FaceColor', 'cyan');
axis equal;
% TRISURF display of surface mesh
% showing mesh edges
```

Compute the feature edges using a filter angle of  $\pi/6$ :

```
tr = TriRep(tri, x,y,z);
fe = featureEdges(tr,pi/6)';
subplot(1,2,2);
trisurf(tr, 'FaceColor', 'cyan', 'EdgeColor','none', ...
 'FaceAlpha', 0.8); axis equal;
```

Add the feature edges to the plot:

```
hold on;
plot3(x(fe), y(fe), z(fe), 'k', 'LineWidth',1.5);
hold off;
% TRISURF display of surface mesh
% suppressing mesh edges
% and showing feature edges
```

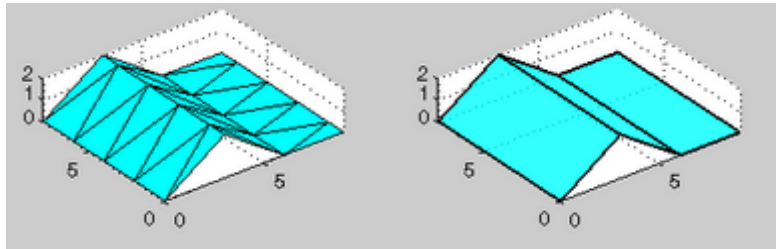

## See Also

`edges` | `delaunayTriangulation` | `triangulation`

# feof

---

**Purpose** Test for end-of-file

**Syntax** `status = feof(fileID)`

**Description** `status = feof(fileID)` returns 1 if a previous operation set the end-of-file indicator for the specified file. Otherwise, `feof` returns 0. `fileID` is an integer file identifier obtained from `fopen`.

Opening an empty file does *not* set the end-of-file indicator. Read operations, and the `fseek` and `frewind` functions, move the file position indicator.

**Examples** Read `bench.dat`, which contains MATLAB benchmark data, one character at a time:

```
fid = fopen('bench.dat');

k = 0;
while ~feof(fid)
 curr = fscanf(fid,'%c',1);
 if ~isempty(curr)
 k = k+1;
 benchstr(k) = curr;
 end
end

fclose(fid);
```

**See Also** `fclose` | `ferror` | `fopen` | `frewind` | `fseek` | `ftell`

**How To** • “Testing for End of File (EOF)”

**Purpose**

Information about file I/O errors

**Syntax**

```
message = ferror(fileID)
[message, errnum] = ferror(fileID)
[...] = ferror(fileID, 'clear')
```

**Description**

*message* = ferror(*fileID*) returns the error message for the most recent file I/O operation on the specified file. If the operation was successful, *message* is an empty string. *fileID* is an integer file identifier obtained from fopen, or an identifier reserved for standard input (0), standard output (1), or standard error (2).

[*message*, *errnum*] = ferror(*fileID*) returns the error number. If the most recent file I/O operation was successful, *errnum* is 0. Negative error numbers correspond to MATLAB error messages. Positive error numbers correspond to C library error messages for your system.

[...] = ferror(*fileID*, 'clear') clears the error indicator for the specified file.

**See Also**

fclose | fopen | fseek | ftell | feof | fscanf | fprintf | fread | fwrite

# feval

---

**Purpose** Evaluate function

**Syntax** `[y1, y2, ...] = feval(fhandle, x1, ..., xn)`  
`[y1, y2, ...] = feval(fname, x1, ..., xn)`

**Description** `[y1, y2, ...] = feval(fhandle, x1, ..., xn)` evaluates the function handle, `fhandle`, using arguments `x1` through `xn`. If the function handle is bound to more than one built-in or `.m` function, (that is, it represents a set of overloaded functions), then the data type of the arguments `x1` through `xn` determines which function is dispatched to.

---

**Note** It is not necessary to use `feval` to call a function by means of a function handle. This is explained in “Calling a Function Using Its Handle” in the MATLAB Programming Fundamentals documentation.

---

`[y1, y2, ...] = feval(fname, x1, ..., xn)`. If `fname` is a quoted string containing the name of a function (usually defined within a file having a `.m` file extension), then `feval(fname, x1, ..., xn)` evaluates that function at the given arguments. The `fname` parameter must be a simple function name; it cannot contain path information.

**Tips** The following two statements are equivalent.

```
[V,D] = eig(A)
[V,D] = feval(@eig, A)
```

Nested functions are not accessible to `feval`. To call a nested function, you must either call it directly by name, or construct a function handle for it using the `@` operator.

**Examples** The following example passes a function handle, `fhandle`, in a call to `fminbnd`. The `fhandle` argument is a handle to the `humps` function.

```
fhandle = @humps;
x = fminbnd(fhandle, 0.3, 1);
```



The `fminbnd` function uses `feval` to evaluate the function handle that was passed in.

```
function [xf, fval, exitflag, output] = ...
 fminbnd(funfcn, ax, bx, options, varargin)
 .
 .
 .
fx = feval(funfcn, x, varargin{:});
```

**See Also**

[assignin](#) | [function\\_handle](#) | [functions](#) | [builtin](#) | [eval](#) | [evalin](#)

# Feval (COM)

---

**Purpose** Evaluate MATLAB function in Automation server

**Syntax** **IDL Method Signature**

```
HRESULT Feval([in] BSTR functionname, [in] long numout,
[out] VARIANT* result, [in, optional] VARIANT arg1, arg2, ...)
```

**Microsoft Visual Basic Client**

```
Feval(String functionname, long numout,
arg1, arg2, ...) As Object
```

**MATLAB Client**

```
result = h.Feval('functionname', numout, arg1, arg2, ...)
result = Feval(h, 'functionname', numout, arg1, arg2, ...)
```

**Description**

`result = h.Feval('functionname', numout, arg1, arg2, ...)` executes the MATLAB function specified by the string `functionname` in the Automation server attached to handle `h`. The function name is case-sensitive.

`result = Feval(h, 'functionname', numout, arg1, arg2, ...)` is an alternate syntax.

Indicate the number of outputs to be returned by the function in a 1-by-1 double array, `numout`. The server returns output from the function in the cell array, `result`.

You can specify as many as 32 input arguments to be passed to the function. These arguments follow `numout` in the `Feval` argument list. The following table shows ways to pass an argument.

| Passing Mechanism           | Description                                                                                                                                                                                                                                                      |
|-----------------------------|------------------------------------------------------------------------------------------------------------------------------------------------------------------------------------------------------------------------------------------------------------------|
| Pass the value itself       | To pass any numeric or string value, specify the value in the Feval argument list:<br><br><code>a = h.Feval('sin', 1, -pi:0.01:pi);</code>                                                                                                                       |
| Pass a client variable      | To pass an argument assigned to a variable in the client, specify the variable name alone:<br><br><code>x = -pi:0.01:pi;<br/>a = h.Feval('sin', 1, x);</code>                                                                                                    |
| Reference a server variable | To reference a variable defined in the server, specify the variable name followed by an equals (=) sign:<br><br><code>h.PutWorkspaceData('x', 'base', -pi:0.01:pi);<br/>a = h.Feval('sin', 1, 'x=');</code><br><br>MATLAB does not reassign the server variable. |

## Tips

To display the output from Feval in the client window, assign a return value.

COM functions are available on Microsoft Windows systems only.

## Examples

### Passing Arguments

This example shows how to pass arguments using Feval to execute MATLAB commands on a MATLAB Automation server from a Visual Basic .NET client.

- Pass two strings to the MATLAB function strcat on the server:

```
Dim Matlab As Object
Dim out As Object
out = Nothing
Matlab = CreateObject("matlab.application")
Matlab.Feval("strcat", 1, out, "hello", " world")
```

# Feval (COM)

---

- Define `clistr` locally and pass this variable:

```
Dim clistr As String
clistr = " world"
Matlab.Feval("strcat", 1, out, "hello", clistr)
```

- Pass the name of a variable defined on the server:

```
Matlab.PutCharArray("srvstr", "base", " world")
Matlab.Feval("strcat", 1, out, "hello", "srvstr=")
```

## Defining Feval Return Values

`Feval` returns data from the evaluated function in a cell array. The cell array has one row for every return value. You control the number of return values using the `numout` argument.

```
Dim Matlab As Object
Dim out As Object
Matlab = CreateObject("matlab.application")
Matlab.Feval("fileparts", 3, out, "d:\work\ConsoleApp.cpp")
```

## See Also

[Execute](#) | [PutFullMatrix](#) | [GetFullMatrix](#) | [PutCharArray](#) | [GetCharArray](#)

**Purpose** Fast Fourier transform

**Syntax**

```
Y = fft(x)
Y = fft(X,n)
Y = fft(X,[],dim)
Y = fft(X,n,dim)
```

**Definitions** The functions  $Y = \text{fft}(x)$  and  $y = \text{ifft}(X)$  implement the transform and inverse transform pair given for vectors of length  $N$  by:

$$X(k) = \sum_{j=1}^N x(j)\omega_N^{(j-1)(k-1)}$$

$$x(j) = (1/N) \sum_{k=1}^N X(k)\omega_N^{-(j-1)(k-1)}$$

where

$$\omega_N = e^{(-2\pi i)/N}$$

is an  $N$ th root of unity.

**Description**  $Y = \text{fft}(x)$  returns the discrete Fourier transform (DFT) of vector  $x$ , computed with a fast Fourier transform (FFT) algorithm.

If the input  $X$  is a matrix,  $Y = \text{fft}(X)$  returns the Fourier transform of each column of the matrix.

If the input  $X$  is a multidimensional array,  $\text{fft}$  operates on the first nonsingleton dimension.

$Y = \text{fft}(X, n)$  returns the  $n$ -point DFT.  $\text{fft}(X)$  is equivalent to  $\text{fft}(X, n)$  where  $n$  is the size of  $X$  in the first nonsingleton dimension. If the length of  $X$  is less than  $n$ ,  $X$  is padded with trailing zeros to length  $n$ . If the length of  $X$  is greater than  $n$ , the sequence  $X$  is truncated. When  $X$  is a matrix, the length of the columns are adjusted in the same manner.

$Y = \text{fft}(X,[],\text{dim})$  and  $Y = \text{fft}(X,n,\text{dim})$  applies the FFT operation across the dimension  $\text{dim}$ .

## Examples

A common use of Fourier transforms is to find the frequency components of a signal buried in a noisy time domain signal. Consider data sampled at 1000 Hz. Form a signal containing a 50 Hz sinusoid of amplitude 0.7 and 120 Hz sinusoid of amplitude 1 and corrupt it with some zero-mean random noise:

```
Fs = 1000; % Sampling frequency
T = 1/Fs; % Sample time
L = 1000; % Length of signal
t = (0:L-1)*T; % Time vector
% Sum of a 50 Hz sinusoid and a 120 Hz sinusoid
x = 0.7*sin(2*pi*50*t) + sin(2*pi*120*t);
y = x + 2*randn(size(t)); % Sinusoids plus noise
plot(Fs*t(1:50),y(1:50))
title('Signal Corrupted with Zero-Mean Random Noise')
xlabel('time (milliseconds)')
```

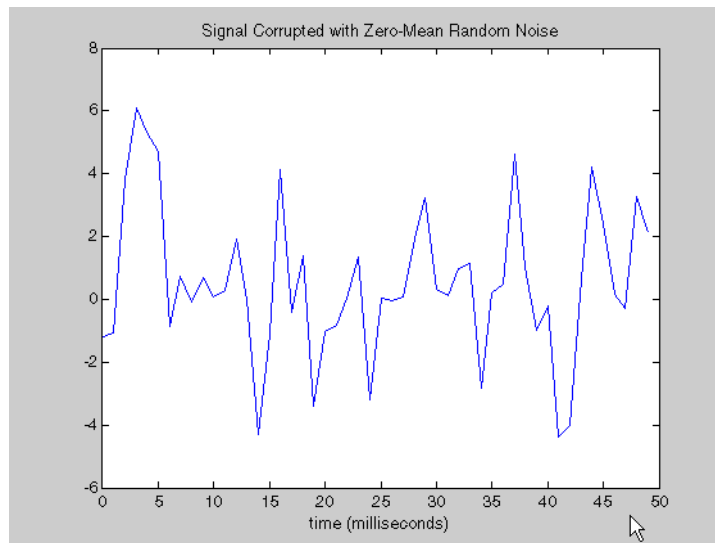

It is difficult to identify the frequency components by looking at the original signal. Converting to the frequency domain, the discrete Fourier transform of the noisy signal  $y$  is found by taking the fast Fourier transform (FFT):

```
NFFT = 2^nextpow2(L); % Next power of 2 from length of y
Y = fft(y,NFFT)/L;
f = Fs/2*linspace(0,1,NFFT/2+1);

% Plot single-sided amplitude spectrum.
plot(f,2*abs(Y(1:NFFT/2+1)))
title('Single-Sided Amplitude Spectrum of y(t)')
xlabel('Frequency (Hz)')
ylabel('|Y(f)|')
```

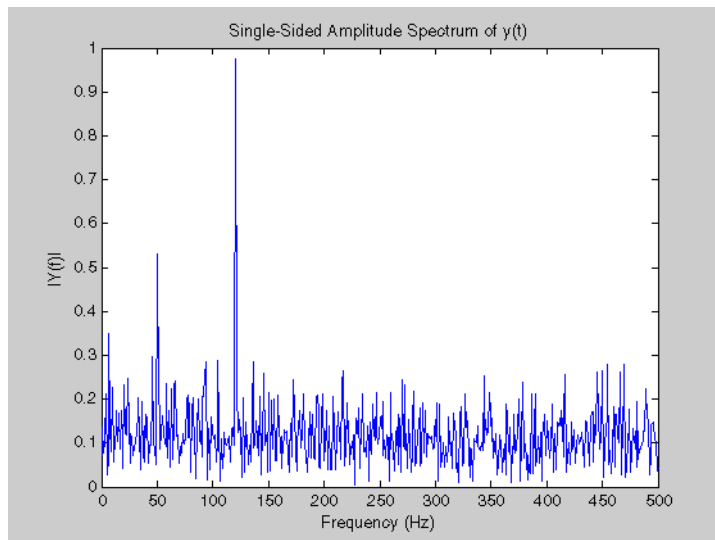

The main reason the amplitudes are not exactly at 0.7 and 1 is because of the noise. Several executions of this code (including recomputation of  $y$ ) will produce different approximations to 0.7 and 1. The other reason is that you have a finite length signal. Increasing  $L$  from 1000 to

10000 in the example above will produce much better approximations on average.

## Algorithms

The FFT functions (`fft`, `fft2`, `fftn`, `ifft`, `ifft2`, `ifftn`) are based on a library called FFTW [3],[4]. To compute an  $N$ -point DFT when  $N$  is composite (that is, when  $N = N_1 N_2$ ), the FFTW library decomposes the problem using the Cooley-Tukey algorithm [1], which first computes  $N_1$  transforms of size  $N_2$ , and then computes  $N_2$  transforms of size  $N_1$ . The decomposition is applied recursively to both the  $N_1$ - and  $N_2$ -point DFTs until the problem can be solved using one of several machine-generated fixed-size "codelets." The codelets in turn use several algorithms in combination, including a variation of Cooley-Tukey [5], a prime factor algorithm [6], and a split-radix algorithm [2]. The particular factorization of  $N$  is chosen heuristically.

When  $N$  is a prime number, the FFTW library first decomposes an  $N$ -point problem into three  $(N - 1)$ -point problems using Rader's algorithm [7]. It then uses the Cooley-Tukey decomposition described above to compute the  $(N - 1)$ -point DFTs.

For most  $N$ , real-input DFTs require roughly half the computation time of complex-input DFTs. However, when  $N$  has large prime factors, there is little or no speed difference.

The execution time for `fft` depends on the length of the transform. It is fastest for powers of two. It is almost as fast for lengths that have only small prime factors. It is typically several times slower for lengths that are prime or which have large prime factors.

---

**Note** You might be able to increase the speed of `fft` using the utility function `fftw`, which controls the optimization of the algorithm used to compute an FFT of a particular size and dimension.

---

## Data Type Support

`fft` supports inputs of data types `double` and `single`. If you call `fft` with the syntax `y = fft(X, ...)`, the output `y` has the same data type as the input `X`.



## References

- [1] Cooley, J. W. and J. W. Tukey, "An Algorithm for the Machine Computation of the Complex Fourier Series," *Mathematics of Computation*, Vol. 19, April 1965, pp. 297-301.
- [2] Duhamel, P. and M. Vetterli, "Fast Fourier Transforms: A Tutorial Review and a State of the Art," *Signal Processing*, Vol. 19, April 1990, pp. 259-299.
- [3] FFTW (<http://www.fftw.org>)
- [4] Frigo, M. and S. G. Johnson, "FFTW: An Adaptive Software Architecture for the FFT," *Proceedings of the International Conference on Acoustics, Speech, and Signal Processing*, Vol. 3, 1998, pp. 1381-1384.
- [5] Oppenheim, A. V. and R. W. Schaffer, *Discrete-Time Signal Processing*, Prentice-Hall, 1989, p. 611.
- [6] Oppenheim, A. V. and R. W. Schaffer, *Discrete-Time Signal Processing*, Prentice-Hall, 1989, p. 619.
- [7] Rader, C. M., "Discrete Fourier Transforms when the Number of Data Samples Is Prime," *Proceedings of the IEEE*, Vol. 56, June 1968, pp. 1107-1108.

## See Also

fft2 | fftn | fftw | fftshift | ifft | filter

# fft2

---

**Purpose** 2-D fast Fourier transform

**Syntax**  
`Y = fft2(X)`  
`Y = fft2(X,m,n)`

**Description** `Y = fft2(X)` returns the two-dimensional discrete Fourier transform (DFT) of `X`. The DFT is computed with a fast Fourier transform (FFT) algorithm. The result, `Y`, is the same size as `X`.

If the dimensionality of `X` is greater than 2, the `fft2` function returns the 2-D DFT for each higher dimensional slice of `X`. For example, if `size(X) = [100 100 3]`, then `fft2` computes the DFT of `X(:, :, 1)`, `X(:, :, 2)` and `X(:, :, 3)`.

`Y = fft2(X,m,n)` truncates `X`, or pads `X` with zeros to create an `m`-by-`n` array before doing the transform. The result is `m`-by-`n`.

**Algorithms** `fft2(X)` can be simply computed as

```
fft(fft(X).').'
```

This computes the one-dimensional DFT of each column `X`, then of each row of the result. The execution time for `fft` depends on the length of the transform. It is fastest for powers of two. It is almost as fast for lengths that have only small prime factors. It is typically several times slower for lengths that are prime or which have large prime factors.

---

**Note** You might be able to increase the speed of `fft2` using the utility function `fftw`, which controls how MATLAB software optimizes the algorithm used to compute an FFT of a particular size and dimension.

---

**Data Type Support** `fft2` supports inputs of data types `double` and `single`. If you call `fft2` with the syntax `y = fft2(X, ...)`, the output `y` has the same data type as the input `X`.

**See Also**`fft | fftn | fftw | fftshift | ifft2`

**Purpose** N-D fast Fourier transform

**Syntax** `Y = fftn(X)`  
`Y = fftn(X,siz)`

**Description** `Y = fftn(X)` returns the discrete Fourier transform (DFT) of `X`, computed with a multidimensional fast Fourier transform (FFT) algorithm. The result `Y` is the same size as `X`.

`Y = fftn(X,siz)` pads `X` with zeros, or truncates `X`, to create a multidimensional array of size `siz` before performing the transform. The size of the result `Y` is `siz`.

**Algorithms** `fftn(X)` is equivalent to

```
Y = X;
for p = 1:length(size(X))
 Y = fft(Y,[],p);
end
```

This computes in-place the one-dimensional fast Fourier transform along each dimension of `X`. The execution time for `fft` depends on the length of the transform. It is fastest for powers of two. It is almost as fast for lengths that have only small prime factors. It is typically several times slower for lengths that are prime or which have large prime factors.

---

**Note** You might be able to increase the speed of `fftn` using the utility function `fftw`, which controls the optimization of the algorithm used to compute an FFT of a particular size and dimension.

---

**Data Type Support** `fftn` supports inputs of data types `double` and `single`. If you call `fftn` with the syntax `y = fftn(X, ...)`, the output `y` has the same data type as the input `X`.

**See Also**

`fft` | `fft2` | `fftw` | `ifftn`

# fftshift

---

**Purpose** Shift zero-frequency component to center of spectrum

**Syntax**  $Y = \text{fftshift}(X)$   
 $Y = \text{fftshift}(X, \text{dim})$

**Description**  $Y = \text{fftshift}(X)$  rearranges the outputs of `fft`, `fft2`, and `fftn` by moving the zero-frequency component to the center of the array. It is useful for visualizing a Fourier transform with the zero-frequency component in the middle of the spectrum.

For vectors, `fftshift(X)` swaps the left and right halves of  $X$ . For matrices, `fftshift(X)` swaps the first quadrant with the third and the second quadrant with the fourth.

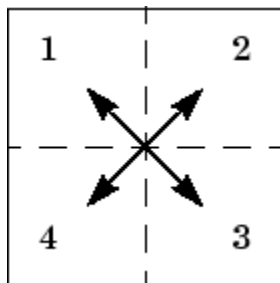

For higher-dimensional arrays, `fftshift(X)` swaps “half-spaces” of  $X$  along each dimension.

$Y = \text{fftshift}(X, \text{dim})$  applies the `fftshift` operation along the dimension `dim`.

For dim = 1:

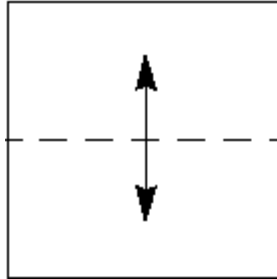

For dim = 2:

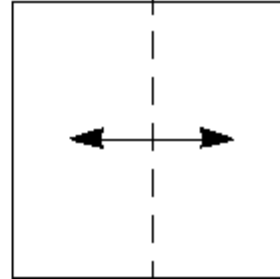

---

**Note** `ifftshift` will undo the results of `fftshift`. If the matrix  $X$  contains an odd number of elements, `ifftshift(fftshift(X))` must be done to obtain the original  $X$ . Simply performing `fftshift(X)` twice will not produce  $X$ .

---

## Examples

For any matrix  $X$

```
Y = fft2(X)
```

has  $Y(1,1) = \text{sum}(\text{sum}(X))$ ; the zero-frequency component of the signal is in the upper-left corner of the two-dimensional FFT. For

```
Z = fftshift(Y)
```

this zero-frequency component is near the center of the matrix.

The difference between `fftshift` and `ifftshift` is important for input sequences of odd-length.

```
N = 5;
X = 0:N-1;
Y = fftshift(fftshift(X));
Z = ifftshift(fftshift(X));
```

Notice that  $Z$  is a correct replica of  $X$ , but  $Y$  is not.

# fftshift

---

```
isequal(X,Y),isequal(X,Z)
```

```
ans =
```

```
 0
```

```
ans =
```

```
 1
```

## See Also

[circshift](#) | [fft](#) | [fft2](#) | [fftn](#) | [ifftshift](#)



**Purpose**

Interface to FFTW library run-time algorithm tuning control

**Syntax**

```
fftw('planner', method)
method = fftw('planner')
str = fftw('dwisdom')
str = fftw('swisdom')
fftw('dwisdom', str)
fftw('swisdom', str)
```

**Description**

fftw enables you to optimize the speed of the MATLAB FFT functions `fft`, `ifft`, `fft2`, `ifft2`, `fftn`, and `ifftn`. You can use `fftw` to set options for a tuning algorithm that experimentally determines the fastest algorithm for computing an FFT of a particular size and dimension at run time. MATLAB software records the optimal algorithm in an internal data base and uses it to compute FFTs of the same size throughout the current session. The tuning algorithm is part of the FFTW library that MATLAB software uses to compute FFTs.

`fftw('planner', method)` sets the method by which the tuning algorithm searches for a good FFT algorithm when the dimension of the FFT is not a power of 2. You can specify `method` to be one of the following. The default method is `estimate`:

- 'estimate'
- 'measure'
- 'patient'
- 'exhaustive'
- 'hybrid'

When you call `fftw('planner', method)`, the next time you call one of the FFT functions, such as `fft`, the tuning algorithm uses the specified method to optimize the FFT computation. Because the tuning involves trying different algorithms, the first time you call an FFT function, it might run more slowly than if you did not call `fftw`. However, subsequent calls to any of the FFT functions, for a problem of the same size, often run more quickly than they would without using `fftw`.

---

**Note** The FFT functions only use the optimal FFT algorithm during the current MATLAB session. “Reusing Optimal FFT Algorithms” on page 1-2058 explains how to reuse the optimal algorithm in a future MATLAB session.

---

If you set the method to 'estimate', the FFTW library does not use run-time tuning to select the algorithms. The resulting algorithms might not be optimal.

If you set the method to 'measure', the FFTW library experiments with many different algorithms to compute an FFT of a given size and chooses the fastest. Setting the method to 'patient' or 'exhaustive' has a similar result, but the library experiments with even more algorithms so that the tuning takes longer the first time you call an FFT function. However, subsequent calls to FFT functions are faster than with 'measure'.

If you set 'planner' to 'hybrid', MATLAB software

- Sets method to 'measure' method for FFT dimensions 8192 or smaller.
- Sets method to 'estimate' for FFT dimensions greater than 8192.

`method = fftw('planner')` returns the current planner method.

`str = fftw('dwisdom')` returns the information in the FFTW library's internal double-precision database as a string. The string can be saved and then later reused in a subsequent MATLAB session using the next syntax.

`str = fftw('swisdom')` returns the information in the FFTW library's internal single-precision database as a string.

`fftw('dwisdom', str)` loads fftw wisdom represented by the string `str` into the FFTW library's internal double-precision wisdom database. `fftw('dwisdom', '')` or `fftw('dwisdom', [])` clears the internal wisdom database.

`fftw('swisdom', str)` loads fftw wisdom represented by the string `str` into the FFTW library's internal single-precision wisdom database. `fftw('swisdom', '')` or `fftw('swisdom', [])` clears the internal wisdom database.

---

**Note on large powers of 2** For FFT dimensions that are powers of 2, between  $2^{14}$  and  $2^{22}$ , MATLAB software uses special preloaded information in its internal database to optimize the FFT computation. No tuning is performed when the dimension of the FFT is a power of 2, unless you clear the database using the command `fftw('wisdom', [])`.

---

For more information about the FFTW library, see <http://www.fftw.org>.

## Examples

### Comparison of Speed for Different Planner Methods

The following example illustrates the run times for different settings of `planner`. The example first creates some data and applies `fft` to it using the default method, `estimate`.

```
t=0:.001:5;
x = sin(2*pi*50*t)+sin(2*pi*120*t);
y = x + 2*randn(size(t));
```

```
tic; Y = fft(y,1458); toc
Elapsed time is 0.000521 seconds.
```

If you execute the commands

```
tic; Y = fft(y,1458); toc
Elapsed time is 0.000151 seconds.
```

a second time, MATLAB software reports the elapsed time as essentially 0. To measure the elapsed time more accurately, you can execute the command `Y = fft(y,1458)` 1000 times in a loop.

```
tic; for k=1:1000
Y = fft(y,1458);
end; toc
Elapsed time is 0.056532 seconds.
```

This tells you that it takes on order of 1/10000 of a second to execute `fft(y, 1458)` a single time.

For comparison, set `planner` to `patient`. Since this planner explores possible algorithms more thoroughly than `hybrid`, the first time you run `fft`, it takes longer to compute the results.

```
fftw('planner','patient')
tic;Y = fft(y,1458);toc
Elapsed time is 0.100637 seconds.
```

However, the next time you call `fft`, it runs at approximately the same speed as before you ran the method `patient`.

```
tic;for k=1:1000
Y=fft(y,1458);
end;toc
Elapsed time is 0.057209 seconds.
```

### **Reusing Optimal FFT Algorithms**

In order to use the optimized FFT algorithm in a future MATLAB session, first save the “wisdom” using the command

```
str = fftw('wisdom')
```

You can save `str` for a future session using the command

```
save str
```

The next time you open a MATLAB session, load `str` using the command

```
load str
```

and then reload the “wisdom” into the FFTW database using the command

```
fftw('wisdom', str)
```

**See Also**

`fft` | `fft2` | `fftn` | `ifft` | `ifft2` | `ifftn` | `fftshift`

# fgetl

---

**Purpose** Read line from file, removing newline characters

**Syntax** `tline = fgetl(fileID)`

**Description** `tline = fgetl(fileID)` returns the next line of the specified file, removing the newline characters. `fileID` is an integer file identifier obtained from `fopen`. `tline` is a text string unless the line contains only the end-of-file marker. In this case, `tline` is the numeric value `-1`.

`fgetl` reads characters using the encoding scheme associated with the file. To specify the encoding scheme, use `fopen`.

**Examples** Read and display the file `fgetl.m` one line at a time:

```
fid = fopen('fgetl.m');

tline = fgetl(fid);
while ischar(tline)
 disp(tline)
 tline = fgetl(fid);
end

fclose(fid);
```

Compare these results to the `fgets` example, which replaces the calls to `fgetl` with `fgets`.

**See Also** `fclose` | `feof` | `ferror` | `fgets` | `fopen` | `fprintf` | `fread` | `fscanf` | `fwrite`

**How To**

- “Testing for EOF with `fgetl` and `fgets`”

**Purpose** Read line of text from device and discard terminator

**Syntax**

```
tline = fgetl(obj)
[tline,count] = fgetl(obj)
[tline,count,msg] = fgetl(obj)
```

**Description** `tline = fgetl(obj)` reads one line of text from the device connected to the serial port object, `obj`, and returns the data to `tline`. This returned data does not include the terminator with the text line. To include the terminator, use `fgets`.

`[tline,count] = fgetl(obj)` returns the number of values read to `count`, including the terminator.

`[tline,count,msg] = fgetl(obj)` returns a warning message to `msg` if the read operation was unsuccessful.

**Tips** Before you can read text from the device, it must be connected to `obj` with the `fopen` function. A connected serial port object has a `Status` property value of `open`. An error is returned if you attempt to perform a read operation while `obj` is not connected to the device.

If `msg` is not included as an output argument and the read operation was not successful, then a warning message is returned to the command line.

The `ValuesReceived` property value is increased by the number of values read – including the terminator – each time `fgetl` is issued.

### Rules for Completing a Read Operation with fgetl

A read operation with `fgetl` blocks access to the MATLAB command line until:

- The terminator specified by the `Terminator` property is reached.
- The time specified by the `Timeout` property passes.
- The input buffer is filled.

**Examples** On a Windows platform, create the serial port object `s`, connect `s` to a Tektronix® TDS 210 oscilloscope, and write the `RS232?` command with

# fgetl (serial)

---

the `fprintf` function. `RS232?` instructs the scope to return serial port communications settings.

```
s = serial('COM1');
fopen(s)
fprintf(s, 'RS232?')
```

Because the default value for the `ReadAsyncMode` property is `continuous`, data is automatically returned to the input buffer.

```
s.BytesAvailable
```

```
ans =
 17
```

Use `fgetl` to read the data returned from the previous write operation, and discard the terminator.

```
settings = fgetl(s)
```

```
settings =
9600;0;0;NONE;LF
```

```
length(settings)
```

```
ans =
 16
```

Disconnect `s` from the scope, and remove `s` from memory and the workspace.

```
fclose(s)
delete(s)
clear s
```

## See Also

`fgets` | `fopen` | `BytesAvailable` | `InputBufferSize` | `ReadAsyncMode` | `Status` | `Terminator` | `Timeout` | `ValuesReceived`



---

|                    |                                                                                                                                                                                                                                                                                                                                                                                                                                                                                                                                                                                                                                                                                |
|--------------------|--------------------------------------------------------------------------------------------------------------------------------------------------------------------------------------------------------------------------------------------------------------------------------------------------------------------------------------------------------------------------------------------------------------------------------------------------------------------------------------------------------------------------------------------------------------------------------------------------------------------------------------------------------------------------------|
| <b>Purpose</b>     | Read line from file, keeping newline characters                                                                                                                                                                                                                                                                                                                                                                                                                                                                                                                                                                                                                                |
| <b>Syntax</b>      | <pre><i>tline</i> = fgets(<i>fileID</i>)<br/><i>tline</i> = fgets(<i>fileID</i>, <i>nchar</i>)</pre>                                                                                                                                                                                                                                                                                                                                                                                                                                                                                                                                                                           |
| <b>Description</b> | <p><i>tline</i> = fgets(<i>fileID</i>) reads the next line of the specified file, including the newline characters. <i>fileID</i> is an integer file identifier obtained from fopen. <i>tline</i> is a text string unless the line contains only the end-of-file marker. In this case, <i>tline</i> is the numeric value -1. fgets reads characters using the encoding scheme associated with the file. To specify the encoding scheme, use fopen.</p> <p><i>tline</i> = fgets(<i>fileID</i>, <i>nchar</i>) returns at most <i>nchar</i> characters of the next line. <i>tline</i> does not include any characters after the newline characters or the end-of-file marker.</p> |
| <b>Examples</b>    | <p>Read and display the file fgets.m. Because fgets keeps newline characters and disp adds a newline character, this code displays the file with double-spacing:</p> <pre>fid = fopen('fgets.m');<br/><br/>tline = fgets(fid);<br/>while ischar(tline)<br/>    disp(tline)<br/>    tline = fgets(fid);<br/>end<br/><br/>fclose(fid);</pre> <p>Compare these results to the fgetl example, which replaces the calls to fgets with fgetl.</p>                                                                                                                                                                                                                                    |
| <b>See Also</b>    | <code>fclose</code>   <code>feof</code>   <code>ferror</code>   <code>fgetl</code>   <code>fopen</code>   <code>fprintf</code>   <code>fread</code>   <code>fscanf</code>   <code>fwrite</code>                                                                                                                                                                                                                                                                                                                                                                                                                                                                                |
| <b>How To</b>      | <ul style="list-style-type: none"><li>• “Testing for EOF with fgetl and fgets”</li></ul>                                                                                                                                                                                                                                                                                                                                                                                                                                                                                                                                                                                       |

# fgets (serial)

---

**Purpose** Read line of text from device and include terminator

**Syntax**

```
tline = fgets(obj)
[tline,count] = fgets(obj)
[tline,count,msg] = fgets(obj)
```

**Description** `tline = fgets(obj)` reads one line of text from the device connected to the serial port object, `obj`, and returns the data to `tline`. This returned data includes the terminator with the text line. To exclude the terminator, use `fgetl`.

`[tline,count] = fgets(obj)` returns the number of values read to `count`, including the terminator.

`[tline,count,msg] = fgets(obj)` returns a warning message to `msg` if the read operation was unsuccessful.

**Tips** Before you can read text from the device, it must be connected to `obj` with the `fopen` function. A connected serial port object has a `Status` property value of `open`. An error is returned if you attempt to perform a read operation while `obj` is not connected to the device.

If `msg` is not included as an output argument and the read operation was not successful, then a warning message is returned to the command line.

The `ValuesReceived` property value is increased by the number of values read – including the terminator – each time `fgets` is issued.

## Rules for Completing a Read Operation with fgets

A read operation with `fgets` blocks access to the MATLAB command line until:

- The terminator specified by the `Terminator` property is reached.
- The time specified by the `Timeout` property passes.
- The input buffer is filled.

**Examples** Create the serial port object `s`, connect `s` to a Tektronix TDS 210 oscilloscope, and write the `RS232?` command with the `fprintf` function.

RS232? instructs the scope to return serial port communications settings.

```
s = serial('COM1');
fopen(s)
fprintf(s, 'RS232?')
```

Because the default value for the ReadAsyncMode property is continuous, data is automatically returned to the input buffer.

```
s.BytesAvailable
```

```
ans =
 17
```

Use fgets to read the data returned from the previous write operation, and include the terminator.

```
settings = fgets(s)
```

```
settings =
9600;0;0;NONE;LF
```

```
length(settings)
```

```
ans =
 17
```

Disconnect s from the scope, and remove s from memory and the workspace.

```
fclose(s)
delete(s)
clear s
```

## See Also

fgetl | fopen | BytesAvailable | BytesAvailableFcn | InputBufferSize | Status | Terminator | Timeout | ValuesReceived

# fieldnames

---

**Purpose** Field names of structure, or public fields of object

**Syntax**

```
names = fieldnames(s)
names = fieldnames(obj)
names = fieldnames(obj, '-full')
```

**Description**

`names = fieldnames(s)` returns a cell array of strings containing the names of the fields in structure `s`.

`names = fieldnames(obj)` returns a cell array of strings containing the names of the public properties of `obj`. MATLAB objects can overload `fieldnames` and define their own behavior.

`names = fieldnames(obj, '-full')` returns a cell array of strings containing the name, type, attributes, and inheritance of the properties of `obj`. Only supported for COM or Java objects.

## Examples

### Structure Fields

Create a structure array and view its fields.

```
s(1,1).name = 'alice';
s(1,1).ID = 0;
s(2,1).name = 'gertrude';
s(2,1).ID = 1;
```

```
names = fieldnames(s)
```

```
names =
 'name'
 'ID'
```

### Java Object Properties

Create a Java® object and view its public properties.

```
obj = java.lang.Integer(0);
names = fieldnames(obj)
```

```
names =

 'MIN_VALUE'
 'MAX_VALUE'
 'TYPE'
 'SIZE'
```

## See Also

setfield | getfield | isfield | orderfields | rmfield

## How To

- “Generate Field Names from Variables”

# figure

---

**Purpose** Create figure graphics object

**Syntax**

```
figure
figure
figure('PropertyName',propertyvalue,...)
figure(h)
h = figure(...)
```

**Properties** For a list of properties, see [Figure Properties](#).

**Description** `figure` creates figure graphics objects. Figure objects are the individual windows on the screen in which the MATLAB software displays graphical output.

`figure` creates a new figure object using default property values. This automatically becomes the current figure and raises it above all other figures on the screen until a new figure is created or called.

`figure` creates a new figure object using default property values. This automatically becomes the current figure and raises it above all other figures on the screen until a new figure is created or called.

Number property has been assigned the smallest positive integer not already assigned to another Figure. This number also appears in the new Figure's title bar.

`figure('PropertyName',propertyvalue,...)` creates a new figure object using the values of the properties specified. For a description of the properties, see [Figure Properties](#). MATLAB uses default values for any properties that you do not explicitly define as arguments.

`figure(h)` does one of the following (assuming `IntegerHandle` is its default value, `on`):

- If `h` is the handle to an existing figure, `figure(h)` makes the figure identified by `h` the current figure, makes it visible, and attempts to raise it above all other figures on the screen. The current figure is the target for graphics output.

- If `h` is not the handle to an existing figure, but is an integer, `figure(h)` creates a figure and assigns it the handle `h`.
- If `h` is not the handle to a figure, and is not an integer, MATLAB returns an error.

`h = figure(...)` returns the handle to the figure object.

## Tips

To create a figure object, MATLAB creates a new window whose characteristics are controlled by default figure properties (both factory installed and user defined) and properties specified as arguments. See [Figure Properties](#) for a description of these properties.

You can specify properties as property name/property value pairs, structure arrays, and cell arrays (see the `set` and `get` reference pages for examples of how to specify these data types).

Use `set` to modify the properties of an existing figure or `get` to query the current values of figure properties.

The `gcf` command returns the handle to the current figure and is useful as an argument to the `set` and `get` commands.

Figures can be docked in the desktop. The `DockControls` property determines whether you can dock the figure.

### Making a Figure Current

The current figure is the target for graphics output. There are two ways to make a figure `h` the current figure.

- Make the figure `h` current, visible, and displayed on top of other figures:

```
figure(h);
```

- Make the figure `h` current, but do not change its visibility or stacking with respect to other figures:

```
set(0, 'CurrentFigure', h);
```

## Examples

### Specifying Figure Size and Screen Location

To create a figure window that is one quarter the size of your screen and is positioned in the upper left corner, use the root object's `ScreenSize` property to determine the size. `ScreenSize` is a four-element vector: [left, bottom, width, height]:

```
scrsz = get(0, 'ScreenSize');
figure('Position', [1 scrsz(4)/2 scrsz(3)/2 scrsz(4)/2])
```

To position the full figure window including the menu bar, title bar, tool bars, and outer edges, use the `OuterPosition` property in the same manner.

### Specifying the Figure Window Title

You can add your own title to a figure by setting the `Name` property and you can turn off the figure number with the `NumberTitle` property:

```
figure('Name', 'Simulation Plot Window', 'NumberTitle', 'off')
```

See [Figure Properties](#) for a description of all properties.

## Setting Default Properties

You can set default figure properties only on the root object level.

```
set(0, 'DefaultFigureProperty', PropertyValue...)
```

where *Property* is the name of the figure property and *PropertyValue* is the value you are specifying. Use `set` and `get` to access figure properties.

See “Setting Default Property Values” for more information.

## See Also

[axes](#) | [close](#) | [clf](#) | [gcf](#) | [ishghandle](#) | [rootobject](#) | [uicontrol](#)  
| [uimenu](#) | [Figure Properties](#)



## Purpose

Define figure properties

## Creating Figure Objects

Use `figure` to create figure objects.

## Modifying Properties

You can set and query graphics object properties in two ways:

- “Customize Objects in Graph” is an interactive tool that enables you to see and change object property values.
- The `set` and `get` commands enable you to set and query the values of Handle Graphics properties.

To change the default values of properties, see “Setting Default Property Values” in the Handle Graphics Objects documentation.

## Figure Property Descriptions

This section provides a description of properties. Curly braces { } enclose default values.

### Alphamap

m-by-1 matrix of alpha values

*Figure alphamap.* An array of non-NaN alpha values. MATLAB accesses alpha values by their row number. For example, an index of 1 specifies the first alpha value, an index of 2 specifies the second alpha value, and so on. Alphamaps can be any length. The default alphamap contains 64 values that progress linearly from 0 to 1.

Alphamaps affect the rendering of surface, image, and patch objects, but do not affect other graphics objects.

### BeingDeleted

on | {off} (read-only)

*This object is being deleted.* Mechanism to determine if objects are in the process of being deleted. MATLAB sets the `BeingDeleted`

# Figure Properties

---

property to `on` when the object's delete function callback is called (see the `DeleteFcn` property). It remains set to `on` while the delete function executes, after which the object no longer exists.

For example, an object's delete function calls other functions that act on a number of different objects. If a function does not need to perform an action on an about-be-deleted object, it can check the object's `BeingDeleted` property before acting.

See the `close` and `delete` function reference pages for related information.

## `BusyAction`

`cancel` | `{queue}`

*Callback function interruption.* The `BusyAction` property enables you to control how MATLAB handles events that potentially interrupt executing callback functions. If there is a callback function executing, callback functions invoked subsequently always attempt to interrupt it. If the `Interruptible` property of the object whose callback is executing is `on` (the default), then interruption occurs at the next point where the event queue is processed. If the `Interruptible` property is `off`, the `BusyAction` property (of the object owning the executing callback) determines how MATLAB handles the event. The choices are

- `cancel` — Discard the event that attempted to execute a second callback function.
- `queue` — Queue the event that attempted to execute a second callback function until the current callback finishes.

## `ButtonDownFcn`

function handle | cell array containing function handle and additional arguments | string (not recommended)

*Button press callback function.* Executes whenever you press a mouse button while the pointer is in the figure window, but not over a child object (i.e., `uicontrol`, `uipanel`, `axes`, or `axes child`).

Define the `ButtonDownFcn` as a function handle. The function must define at least two input arguments (handle of figure associated with the mouse button press and an empty event structure).

See the figure's `SelectionType` property to determine whether modifier keys were also pressed.

For information on the syntax of callback functions, see [Function Handle Callbacks](#).

## Using the `ButtonDownFcn`

This example creates a figure and defines a function handle callback for the `ButtonDownFcn` property. When the user **Ctrl**-clicks the figure, the callback creates a new figure having the same callback.

[Click to view in editor](#) — This link opens the MATLAB Editor with the following example.

[Click to run example](#) — **Ctrl**-click the figure to create a new figure.

```
fh_cb = @newfig; % Create function handle for newfig function
figure('ButtonDownFcn',fh_cb);

function newfig(src,evnt)
 if strcmp(get(src,'SelectionType'),'alt')
 figure('ButtonDownFcn',fh_cb)
 else
 disp('Use control-click to create a new figure')
 end
end
```

Children  
vector of handles

# Figure Properties

---

*Children of the figure.* A vector containing the handles of all axes, user-interface objects displayed within the figure. You can change the order of the handles and thereby change the stacking of the objects on the display.

When an object's `HandleVisibility` property is `off`, it is not listed in its parent's `Children` property. See `HandleVisibility` for more information.

## Clipping

{on} | off

*Clipping mode.* This property has no effect on figures.

## CloseRequestFcn

function handle | cell array containing function handle and additional arguments | string (not recommended)

*Function executed on figure close.* Executes whenever you issue the `close` command (either a `close(figure_handle)` or a `close all`), when you close a figure window from the computer's window manager menu, or when you quit MATLAB.

The `CloseRequestFcn` provides a mechanism to intervene in the closing of a figure. It allows you to, for example, display a dialog box to ask a user to confirm or cancel the close operation or to prevent users from closing a figure that contains a GUI.

The basic mechanism is:

- 1 A user issues the `close` command from the command line, by closing the window from the computer's window manager menu, or by quitting MATLAB.
- 2 The close operation executes the function defined by the figure `CloseRequestFcn`. The default function is `closereq`.

`closereq` unconditionally deletes the current figure, destroying the window. `closereq` takes advantage of the fact that the

`close` command makes each figure specified as arguments the current figure before calling its respective close request function.

Note that `closereq` honors the `ShowHiddenHandles` setting during figure deletion and will not delete hidden figures.

## Redefining the `CloseRequestFcn`

Define the `CloseRequestFcn` as a function handle. For example:

```
set(gcf, 'CloseRequestFcn', @my_closefcn)
```

Where `@my_closefcn` is a function handle referencing function `my_closefcn`.

Unless the close request function calls `delete` or `close`, MATLAB never closes the figure. (Note that you can always call `delete(figure_handle)` from the command line if you have created a window with a nondestructive close request function.)

A useful application of the close request function is to display a question dialog box asking the user to confirm the close operation. The following function illustrates how to do this.

[Click to view in editor](#) — This link opens the MATLAB editor with the following example.

[Click to run example](#) — **Ctrl-** click the figure to create a new figure.

```
function my_closereq(src, evnt)
% User-defined close request function
% to display a question dialog box
 selection = questdlg('Close This Figure?', ...
 'Close Request Function', ...
 'Yes', 'No', 'Yes');
 switch selection,
```

# Figure Properties

---

```
 case 'Yes',
 delete(gcf)
 case 'No'
 return
 end
end
```

Now create a figure using the `CloseRequestFcn`:

```
figure('CloseRequestFcn',@my_closereq)
```

To make this function your default close request function, set a default value on the root level.

```
set(0,'DefaultFigureCloseRequestFcn',@my_closereq)
```

MATLAB then uses this setting for the `CloseRequestFcn` of all subsequently created figures.

See “Function Handle Callbacks” for information on how to use function handles to define the callback function.

## Color

### ColorSpec

*Background color.* Controls the figure window background color. You can specify a color using a three-element vector of RGB values or one of the MATLAB predefined names. See `ColorSpec` for more information.

## Colormap

m-by-3 matrix of RGB values

*Figure colormap.* An array of red, green, and blue (RGB) intensity values that define *m* individual colors. MATLAB accesses colors by their row number. For example, an index of 1 specifies the first RGB triplet, an index of 2 specifies the second RGB triplet, and so on.

## Number of Colors Allowed

Colormaps can be any length, but must be three columns wide. The default figure colormap contains 64 predefined colors.

## Objects That Use Colormaps

Colormaps affect the rendering of surface, image, and patch objects, but generally do not affect other graphics objects. See `colormap` and `ColorSpec` for more information.

### CreateFcn

function handle | cell array containing function handle and additional arguments | string (not recommended)

*Callback function executed during figure creation.* Executes when MATLAB creates a figure object. You must define this property as a default value on the root level. For example, the statement:

```
set(0,'DefaultFigureCreateFcn',@fig_create)
```

defines a default value on the root level that causes all figures created to execute the setup function `fig_create`, which is defined below:

```
function fig_create(src,evnt)
set(src,'Color',[.2 .1 .5],...
 'IntegerHandle','off',...
 'MenuBar','none',...
 'ToolBar','none')
end
```

MATLAB executes the create function after setting all properties for the figure. Setting this property on an existing figure object has no effect.

See “Function Handle Callbacks” for information on how to use function handles to define the callback function.

# Figure Properties

---

The handle of the object whose `CreateFcn` is being executed is accessible only through the root `CallbackObject` property, which you can query using `gcbo` or the handle of the object generating the callback (the source of the event). For example, this,

```
f = figure('CreateFcn',@(o,e) keyboard)
K>> gcbo
```

and this each return 1:

```
f = figure('CreateFcn',@(o,e) keyboard)
K>> o
```

## CurrentAxes

handle of current axes

*Target axes in this figure.* MATLAB sets this property to the handle of the figure's current axes (the handle returned by the `gca` command when this figure is the current figure). In all figures for which axes children exist, there is always a current axes. The current axes does not have to be the topmost axes, and setting an axes to be the `CurrentAxes` does not restack it above all other axes.

You can make an axes current using the `axes` and `set` commands. For example, `axes(axes_handle)` and `set(gcf, 'CurrentAxes', axes_handle)` both make the axes identified by the handle *axes\_handle* the current axes. In addition, `axes(axes_handle)` restacks the axes above all other axes in the figure.

If a figure contains no axes, `get(gcf, 'CurrentAxes')` returns the empty matrix. Note that the `gca` function actually creates an axes if one does not exist.

## CurrentCharacter

single character



*Last key pressed.* MATLAB sets this property to the last key pressed in the figure window. Use `CurrentCharacter` to obtain user input.

`CurrentObject`  
object handle

*Handle of current object.* MATLAB sets this property to the handle of the last object clicked on by the mouse. This object is the foremost object in the view. You can use this property to determine which object a user has selected. The function `gco` provides a convenient way to retrieve the `CurrentObject` of the `CurrentFigure`.

Note that the `HitTest` property controls whether an object can become the `CurrentObject`.

## Hidden Handle Objects

Clicking an object whose `HandleVisibility` property is `off` (such as axis labels and title) causes the `CurrentObject` property to be set to empty `[]`. To avoid returning an empty value when users click hidden objects, set the hidden object's `HitTest` property to `off`.

## Mouse Over

Note that cursor motion over objects does not update the `CurrentObject`; you must click objects to update this property. See the `CurrentPoint` property for related information.

`CurrentPoint`  
two-element vector: [*x*-coordinate, *y*-coordinate]

*Location of last button click in this figure.* MATLAB sets this property to the location of the pointer at the time of the most recent mouse button press. MATLAB updates this property

# Figure Properties

---

whenever you press the mouse button while the pointer is in the figure window.

Note that if you select a point in the figure and then use the values returned by the `CurrentPoint` property to plot that point, there can be differences in the position due to round-off errors.

## CurrentPoint and Cursor Motion

In addition to the behavior described above, MATLAB updates `CurrentPoint` before executing callback routines defined for the figure `WindowButtonMotionFcn` and `WindowButtonUpFcn` properties. This enables you to query `CurrentPoint` from these callback routines. It behaves like this:

- If there is no callback routine defined for the `WindowButtonMotionFcn` or the `WindowButtonUpFcn`, then MATLAB updates the `CurrentPoint` only when the mouse button is pressed down within the figure window.
- If there is a callback routine defined for the `WindowButtonMotionFcn`, then MATLAB updates the `CurrentPoint` just before executing the callback. Note that the `WindowButtonMotionFcn` executes only within the figure window unless the mouse button is pressed down within the window and then held down while the pointer is moved around the screen. In this case, the routine executes (and the `CurrentPoint` is updated) anywhere on the screen until the mouse button is released.
- If there is a callback routine defined for the `WindowButtonUpFcn`, MATLAB updates the `CurrentPoint` just before executing the callback. Note that the `WindowButtonUpFcn` executes only while the pointer is within the figure window unless the mouse button is pressed down initially within the window. In this case, releasing the button anywhere on the screen triggers callback execution, which is preceded by an update of the `CurrentPoint`.

The figure `CurrentPoint` is updated only when certain events occur, as previously described. In some situations (such as when the `WindowButtonMotionFcn` takes a long time to execute and the pointer is moved very rapidly), the `CurrentPoint` might not reflect the actual location of the pointer, but rather the location at the time when the `WindowButtonMotionFcn` began execution.

The `CurrentPoint` is measured from the lower-left corner of the figure window, in units determined by the `Units` property.

The root `PointerLocation` property contains the location of the pointer updated synchronously with pointer movement. However, the location is measured with respect to the screen, not a figure window.

See `uicontrol` for information on how this property is set when you click a `uicontrol` object.

## `DeleteFcn`

function handle | cell array containing function handle and additional arguments | string (not recommended)

*Delete figure callback function.* Executes when the figure object is deleted (for example, when you issue a `delete` or a `close` command). MATLAB executes the function before destroying the object's properties so these values are available to the callback routine.

See “Function Handle Callbacks” for information on how to use function handles to define the callback function.

The handle of the object whose `DeleteFcn` is being executed is accessible through the root `CallbackObject` property, which you can query using `gcbo`.

See also the figure `CloseRequestFcn` property

# Figure Properties

---

See “Function Handle Callbacks” for information on how to use function handles to define the callback function.

DockControls  
{on} | off

*Displays controls used to dock figure.* Determines whether the figure enables the **Desktop** menu item and the dock figure button in the title bar that allow you to dock the figure into the MATLAB desktop.

- on — Figure docking controls are visible.
- off — The **Desktop** menu item that enables you to dock the figure is disabled and the figure dock button is not displayed.

See the `WindowState` property for more information on docking figure.

DoubleBuffer  
{on} | off

---

**Note** This property is now obsolete and has no effect. It was provided for older computer systems to produce flash-free animations.

---

*Flash-free rendering for simple animations.* Double buffering is the process of drawing to an off-screen pixel buffer and then printing the buffer contents to the screen once the drawing is complete. Double buffering generally produces flash-free rendering for simple animations (such as those involving lines, as opposed to objects containing large numbers of polygons). Use double buffering with the animated objects’ `EraseMode` property set to `normal`. Use the `set` command to disable double buffering.

```
set(figure_handle, 'DoubleBuffer', 'off')
```

Double buffering works only when the figure `Renderer` property is `painters`.

**FileName**  
String

*GUI FIG-file name.* GUIDE stores the name of the FIG-file used to save the GUI layout in this property. In non-GUIDE GUIs, by default `FileName` is empty. You can set the `FileName` property in non-GUIDE GUIs as well, and get it to verify what GUI is running or whether it has been previously saved.

**FixedColors**  
m-by-3 matrix of RGB values (read-only)

*Noncolormap colors.* Fixed colors define all colors appearing in a figure window that are not from the figure colormap. These colors include axis lines and labels, the colors of `line`, `text`, `uicontrol`, and `uimenu`, and `text` objects, and any colors explicitly defined, for example, with a statement like:

```
set(gcf, 'Color', [0.3,0.7,0.9])
```

Fixed color definitions reside in the system color table and do not appear in the figure colormap. For this reason, fixed colors can limit the number of simultaneously displayed colors if the number of fixed colors plus the number of entries in the figure colormap exceed your system's maximum number of colors.

(See the root `ScreenDepth` property for information on determining the total number of colors supported on your system. See the `MinColorMap` property for information on how MATLAB shares colors between applications.)

---

**Note** The `FixedColors` property is being deprecated and will be removed in a future release

---

# Figure Properties

---

`HandleVisibility`  
`{on} | callback | off`

*Control access to object's handle.* Determines when an object's handle is visible in its parent's list of children. `HandleVisibility` is useful for preventing command-line users from accidentally drawing into or deleting a figure that contains only user interface devices (such as a dialog box).

Handles are always visible when `HandleVisibility` is `on`.

- `on` — Handles are always visible.
- `callback` — Handles are visible from within callback routines or functions invoked by callback routines, but not from within functions invoked from the command line. This provides a means to protect GUIs from command-line users, while allowing callback routines to have access to object handles.
- `off` — Handles are invisible at all times. Use this option when a callback invokes a function that could damage the GUI (such as evaluating a user-typed string). This option temporarily hides its own handles during the execution of that function.

## Visibility and Handles Returned by Other Functions

When a handle is not visible in its parent's list of children, it cannot be returned by functions that obtain handles by searching the object hierarchy or querying handle properties. This includes `get`, `findobj`, `gca`, `gcf`, `gco`, `newplot`, `cla`, `clf`, and `close`.

When a handle's visibility is restricted using `callback` or `off`, the object's handle does not appear in its parent's `Children` property, figures do not appear in the root's `CurrentFigure` property, objects do not appear in the root's `CallbackObject` property or in the figure's `CurrentObject` property, and axes do not appear in their parent's `CurrentAxes` property.

## Making All Handles Visible

You can set the root `ShowHiddenHandles` property to `on` to make all handles visible, regardless of their `HandleVisibility` settings (this does not affect the values of the `HandleVisibility` properties).

## Validity of Hidden Handles

Handles that are hidden are still valid. If you know an object's handle, you can pass it to any function that operates on handles, and set and get its properties.

`HitTest`  
{on} | off

*Selectable by mouse click.* Determines if the figure can become the current object (as returned by the `gco` command and the figure `CurrentObject` property) as a result of a mouse click on the figure. If `HitTest` is `off`, clicking the figure sets the `CurrentObject` to the empty matrix.

`IntegerHandle`  
{on} | off

*Figure handle mode.* Figure object handles are integers by default. When creating a new figure, MATLAB uses the lowest integer that is not used by an existing figure. If you delete a figure, its integer handle can be reused.

If you set this property to `off`, MATLAB assigns nonreusable real-number handles (for example, `67.0001221`) instead of integers. This feature is designed for dialog boxes where removing the handle from integer values reduces the likelihood of inadvertently drawing into the dialog box.

`Interruptible`  
{on} | off

# Figure Properties

---

*Callback routine interruption mode.* Controls whether a figure callback function can be interrupted by subsequently invoked callbacks.

## How Callbacks Are Interrupted

MATLAB checks for queued events that can interrupt a callback function only when it encounters a call to `drawnow`, `figure`, `getframe`, or `pause` in the executing callback function. When executing one of these functions, MATLAB processes all pending events, including executing all waiting callback functions. The interrupted callback then resumes execution.

## What Property Callbacks Are Interruptible

The `Interruptible` property only affects callback functions defined for the `ButtonDownFcn`, `KeyPressFcn`, `KeyReleaseFcn`, `WindowButtonDownFcn`, `WindowButtonMotionFcn`, `WindowButtonUpFcn`, `WindowKeyPressFcn`, `WindowKeyReleaseFcn`, and `WindowScrollWheelFcn`.

See the `BusyAction` property for related information.

`InvertHardcopy`  
{on} | off

*Change hardcopy to black objects on white background.* Affects only exported and printed output. Printing a figure having a background color (`Color` property) that is not white results in poor contrast between graphics objects and the figure background and also consumes a lot of printer toner.

When `InvertHardCopy` is on, MATLAB eliminates this effect by changing the color of the figure and axes to white and the axis lines, tick marks, axis labels, etc., to black. Lines, text, and the edges of patches and surfaces might be changed, depending on the print command options specified.



If you set `InvertHardCopy` to `off`, the exported and printed output matches the colors displayed on the screen.

See `print` for more information on printing MATLAB figures.

## `KeyPressFcn`

function handle | cell array containing function handle and additional arguments | string (not recommended)

*Key press callback function.* Callback function invoked by a key press that occurs while the figure window has focus. Define the `KeyPressFcn` as a function handle. The function must define at least two input arguments (handle of figure associated with key press and an event structure).

For information on the syntax of callback functions, see [Function Handle Callbacks](#).

When no callback is specified for this property (which is the default state), MATLAB passes any key presses to the Command Window. However, when you define a callback for this property, the figure retains focus with each key press and executes the specified callback with each key press.

## **KeyPressFcn Event Structure**

When you specify the callback as a function handle, MATLAB passes to it a structure to containing the following fields.

# Figure Properties

---

| Field     | Contents                                                                                                                                                                                                                      |
|-----------|-------------------------------------------------------------------------------------------------------------------------------------------------------------------------------------------------------------------------------|
| Character | The character displayed as a result of the pressing the key(s), which can be empty or unprintable                                                                                                                             |
| Key       | The key being pressed, identified by the lowercase label on key or a descriptive string                                                                                                                                       |
| Modifier  | A cell array containing the names of one or more modifier keys being pressed (i.e., <b>control</b> , <b>alt</b> , <b>shift</b> ). On Macintosh computers, it contains 'command' when pressing the <b>command</b> modifier key |

## ExploreKeyPressFcn Behavior

To view the values of the event data fields for any key or key combination, run the following code:

```
figure('NumberTitle','off','Menubar','none',...
 'Name',...
 'Press keys to put event data in Command Window',...
 'Position',[560 728 560 200],...
 'KeyPressFcn',@(obj,evt)disp(evt));
```

Each time you press a key, the `KeyPressFcn` uses `disp` to display the event data in the Command Window.

You can also view and run an example GUI, `ex_KeyPressFcn.m`, which displays keystroke event data in the figure window, and provides an option to write the event data structure to your workspace.

- [Click here to view the example in the MATLAB editor](#)
- [Click here to add the example to the MATLAB path](#)
- [Click to run the example](#) — Press and release various key combinations while the figure has focus. The callback displays

event data in text fields in the figure window. The **Char Code** data is the Character field displayed as a number, not a separate event data field.

Event data passed to a `KeyPressFcn` and `KeyReleaseFcn` callbacks have the following characteristics:

- The `Key` field is always in lower case (contains the non-shifted symbol).
- Modifier keys (**Alt**, **Ctrl**, **Shift**,) return data when pressed alone as well as when pressed in combination with other keys.
- `Modifier` fields contain a cell array with zero or more strings.
- Modifier keys can affect the `Character` field, but do not change the `Key` field.
- Certain keys, plus keys modified with **Ctrl**, put unprintable characters in the `Character` field.
- **Ctrl**, **Alt**, **Shift**, function and several other keys generate no `Character` field data.

## Using the `KeyPressFcn`

This example creates a figure and defines a function handle callback for the `KeyPressFcn` property. When you press the **p** key, the callback exports the figure as a PNG image file. When you press **Ctrl+p**, the callback exports the figure as a PDF file.

```
function figure_keypress
 figure('KeyPressFcn',@printfig);
 surf(peaks)

 function printfig(src,event)
 % Callback to parse keypress event data to print a figure
 if event.Character == 'p'
 % On some systems you must send the file to a printer manually
 if length(event.Modifier) == 1 && ...
```

# Figure Properties

---

```
 strcmp(event.Modifier{:},'control')
 % Create PDF file of figure when Ctrl key is down
 print ('-dpdf',['-f' num2str(src)])
 elseif isempty(event.Modifier)
 % Print PNG image of figure when Ctrl is not pressed
 print ('-dpng','-r200',['-f' num2str(src)])
 end
end
end
end
```

## KeyReleaseFcn

function handle | cell array containing function handle and additional arguments | string (not recommended)

*Key release callback function.* Callback function invoked by a key release that occurs while the figure window has focus. Define the `KeyReleaseFcn` as a function handle. The function must define at least two input arguments (handle of figure associated with key release and an event structure).

For information on the syntax of callback functions, see [Function Handle Callbacks](#).

## KeyReleaseFcn Event Structure

When the callback is a function handle, MATLAB passes a structure as the second argument to the callback function that contains the following fields.

| Field     | Contents                                                                                                                                                                                                                        |
|-----------|---------------------------------------------------------------------------------------------------------------------------------------------------------------------------------------------------------------------------------|
| Character | The character displayed as a result of the releasing the key(s), which can be empty or unprintable                                                                                                                              |
| Key       | The key being released, identified by the lowercase label on key or a descriptive string                                                                                                                                        |
| Modifier  | A cell array containing the names of one or more modifier keys being released (i.e., <b>control</b> , <b>alt</b> , <b>shift</b> ). On Macintosh computers, it contains 'command' when releasing the <b>command</b> modifier key |

## Properties Affected by the KeyReleaseFcn

When a callback is defined for the KeyReleaseFcn property, MATLAB updates the CurrentCharacter figure property just before executing the callback.

## Multiple-Key Press Events and a Single-Key Release Event

Consider a figure having callbacks defined for both the KeyPressFcn and KeyReleaseFcn. In the case where you press multiple keys at close to the same time, MATLAB generates repeated KeyPressFcn events only for the last key pressed.

For example, suppose you press and hold down the **a** key, then press and hold down the **s** key. MATLAB generates repeated KeyPressFcn events for the **a** key until you press the **s** key, at which point MATLAB generates repeated KeyPressFcn events for the **s** key. If you then release the **s** key, MATLAB generates a KeyReleaseFcn event for the **s** key, but no new KeyPressFcn events for the **a** key. When you then release the **a** key, the KeyReleaseFcn again executes. The KeyReleaseFcn executes its callback every time you release a key while the figure is in focus, regardless of what any KeyPressFcn does.

# Figure Properties

---

Event structures passed to a `KeyPressFcn` and `KeyReleaseFcn` callbacks have the following characteristics:

- The `Key` field is always in lower case (contains the non-shifted symbol).
- Modifier keys (**Alt**, **Ctrl**, **Shift**,) return data when pressed alone as well as when pressed in combination with other keys.
- `Modifier` fields contain a cell array with zero or more strings.
- Modifier keys can affect the `Character` field, but do not change the `Key` field.
- Certain keys, plus keys modified with **Ctrl**, put unprintable characters in the `Character` field.
- **Ctrl**, **Alt**, **Shift**, function and several other keys generate no `Character` field data.

## Modifier Keys

When you press and release a key and a modifier key, the modifier key is returned in the event structure `Modifier` field. If you press and release a modifier key only, its name is not returned in the event structure of the `KeyReleaseFcn`, but is returned in the event structure of the `KeyPressFcn`.

## Explore `KeyReleaseFcn` Behavior

The following code example creates a figure and defines a function handle callback for the `KeyReleaseFcn` property which reports the event data that the callback receives.

- [Click here to view the example in the MATLAB editor](#)
- [Click here to add the example to the MATLAB path](#)
- [Click to run the example](#) — Press and release various key combinations while the figure has focus. The callback displays event data in the Command Window.

```
function key_releaseFcn
figure('KeyReleaseFcn',@cb)
function cb(src,evt)
if ~isempty(evt.Modifier)
for ii = 1:length(evt.Modifier)
out = sprintf('Character: %c\nModifier: %s\nKey: %s\n',...
evt.Character,evt.Modifier{ii},evt.Key);
disp(out)
end
else
out = sprintf('Character: %c\nModifier: %s\nKey: %s\n',...
evt.Character,'No modifier key',evt.Key);
disp(out)
end
end
end
```

## MenuBar

none | {figure}

*Enable-disable figure menu bar.* Enables you to display or hide the menu bar that MATLAB places at the top of a figure window. The default (figure) is to display the menu bar.

This property affects only built-in menus. This property does not affect menus defined with the `uimenu` command.

Changing the `WindowStyle` of a window to 'modal' hides both its toolbar and menu bar, if they exist. Changing `WindowStyle` from 'modal' to 'normal' or 'docked' displays any toolbar or menu bar a figure has.

## MinColormap

scalar (default = 64)

*Minimum number of color table entries used.* Specifies the minimum number of system color table entries used by MATLAB to store the colormap defined for the figure (see the `Colormap`

# Figure Properties

---

property). In certain situations, you might need to increase this value to ensure proper use of colors.

For example, suppose you run color-intensive applications in addition to MATLAB and have defined a large figure colormap (for example, 150 to 200 colors). MATLAB might select colors that are close but not exact from the existing colors in the system color table because there are not enough slots available to define all the colors you specified.

To ensure that MATLAB uses exactly the colors you define in the figure colormap, set `MinColormap` equal to the length of the colormap.

```
set(gcf, 'MinColormap', length(get(gcf, 'ColorMap')))
```

Note that the larger the value of `MinColormap`, the greater the likelihood that other windows (including other MATLAB figure windows) will be displayed in false colors.

---

**Note** The `MinColormap` property is being deprecated and will be removed in a future release

---

Name

string

*Figure window title.* Specifies the title displayed in the figure window. By default, Name is empty and the figure title is displayed as Figure 1, Figure 2, and so on. When you set this parameter to a string, the figure title becomes Figure 1: *<string>*. See the `NumberTitle` property.

NextPlot

new | {add} | replace | replacechildren



*How to add next plot.* Determines which figure MATLAB uses to display graphics output. If the value of the current figure is:

- **new** — Create a new figure to display graphics (unless an existing parent is specified in the graphing function as a property/value pair).
- **add** — Use the current figure to display graphics (the default).
- **replace** — Reset all figure properties except **Position** to their defaults and delete all figure children before displaying graphics (equivalent to `clf reset`).
- **replacechildren** — Remove all child objects, but do not reset figure properties (equivalent to `clf`).

The `newplot` function provides an easy way to handle the `NextPlot` property. For more information, see the axes `NextPlot` property and “Controlling Graphics Output”.

**NumberTitle**

`{on} | off` (GUIDE default `off`)

*Figure window title number string.* Determines whether the string `Figure No. N` (where `N` is the figure number) is prefixed to the figure window title. See the `Name` property.

**OuterPosition**

four-element vector

*Figure position including title bar, menu bar, tool bars, and outer edges.* Specifies the size and location on the screen of the full figure window including the title bar, menu bar, tool bars, and outer edges. Specify the position rectangle with a four-element vector of the form:

```
rect = [left, bottom, width, height]
```

where `left` and `bottom` define the distance from the lower-left corner of the screen to the lower-left corner of the full figure

# Figure Properties

---

window. `width` and `height` define the dimensions of the window. See the `Units` property for information on the units used in this specification. The `left` and `bottom` elements can be negative on systems that have more than one monitor.

## Position of Docked Figures

If the figure is docked in the MATLAB desktop, then the `OuterPosition` property is specified with respect to the figure group container instead of the screen.

## Moving and Resizing Figures

Use the `get` function to obtain this property and determine the position of the figure. Use the `set` function to resize and move the figure to a new location. You cannot set the figure `OuterPosition` when it is docked.

---

**Note** On Microsoft Windows systems, figure windows cannot be less than 104 pixels wide, regardless of the value of the `OuterPosition` property.

---

`PaperOrientation`  
{portrait} | landscape

*Horizontal or vertical paper orientation.* Determines how to orient printed figures on the page.

- `portrait` — Orients the longest page dimension vertically.
- `landscape` — Orients the longest page dimension horizontally.

See the `orient` command for more information.

`PaperPosition`  
four-element rect vector

*Location on printed page.* A rectangle that determines the location of the figure on the printed page. Specify this rectangle with a vector of the form:

```
rect = [left, bottom, width, height]
```

where `left` specifies the distance from the left side of the paper to the left side of the rectangle and `bottom` specifies the distance from the bottom of the page to the bottom of the rectangle. Together these distances define the lower-left corner of the rectangle. `width` and `height` define the dimensions of the rectangle. The `PaperUnits` property specifies the units used to define this rectangle.

`PaperPositionMode`  
auto | {manual}

*WYSIWYG printing of figure.*

- `manual` — MATLAB honors the value specified by the `PaperPosition` property.
- `auto` — MATLAB prints the figure the same size as it appears on the computer screen, centered on the page.

`PaperSize`  
[width height]

*Paper size.* Size of the current `PaperType`, measured in `PaperUnits`. See `PaperType` to select standard paper sizes.

`PaperType`  
Select a value from the following table.

*Selection of standard paper size.* Sets the `PaperSize` to one of the following standard sizes.

# Figure Properties

---

**Paper Sizes Table**

| <b>Property Value</b> | <b>Size (Width x Height)</b> |
|-----------------------|------------------------------|
| usletter (default)    | 8.5-by-11 inches             |
| uslegal               | 8.5-by-14 inches             |
| tabloid               | 11-by-17 inches              |
| A0                    | 841-by-1189 mm               |
| A1                    | 594-by-841 mm                |
| A2                    | 420-by-594 mm                |
| A3                    | 297-by-420 mm                |
| A4                    | 210-by-297 mm                |
| A5                    | 148-by-210 mm                |
| B0                    | 1029-by-1456 mm              |
| B1                    | 728-by-1028 mm               |
| B2                    | 514-by-728 mm                |
| B3                    | 364-by-514 mm                |
| B4                    | 257-by-364 mm                |
| B5                    | 182-by-257 mm                |
| arch-A                | 9-by-12 inches               |
| arch-B                | 12-by-18 inches              |
| arch-C                | 18-by-24 inches              |
| arch-D                | 24-by-36 inches              |
| arch-E                | 36-by-48 inches              |
| A                     | 8.5-by-11 inches             |
| B                     | 11-by-17 inches              |
| C                     | 17-by-22 inches              |

| Property Value | Size (Width x Height) |
|----------------|-----------------------|
| D              | 22-by-34 inches       |
| E              | 34-by-43 inches       |

Note that you might need to change the `PaperPosition` property in order to position the printed figure on the new paper size. One solution is to use normalized `PaperUnits`, which enables MATLAB to automatically size the figure to occupy the same relative amount of the printed page, regardless of the paper size.

## PaperUnits

normalized | {inches} | centimeters | points

*Hardcopy measurement units.* Specifies the units used to define the `PaperPosition` and `PaperSize` properties. MATLAB measures all units from the lower-left corner of the page. normalized units map the lower-left corner of the page to (0, 0) and the upper-right corner to (1.0, 1.0). inches, centimeters, and points are absolute units (one point equals 1/72 of an inch).

If you change the value of `PaperUnits`, it is good practice to return the property to its default value after completing your computation so as not to affect other functions that assume `PaperUnits` is set to the default value.

## Parent

handle

*Handle of figure's parent.* The parent of a figure object is the root object `object`. The handle to the root is always 0.

## Pointer

crosshair | {arrow} | watch | topl |  
topr | botl | botr | circle | cross |  
fleur | left | right | top | bottom |  
fullcrosshair | ibeam | custom | hand

# Figure Properties

---

Pointer symbol, specified as a string listed in the following table. By convention, each symbol commonly indicates a particular usage. However, MATLAB does not enforce rules for the use of any symbols. The appearance of the symbol that displays for a given string is operating-system dependent.

| <b>Commonly Indicates</b>                                 | <b>Symbol String</b> |
|-----------------------------------------------------------|----------------------|
| Editing location in text                                  | 'ibeam'              |
| Point on a graphics object                                | 'crosshair'          |
| Point anywhere in the figure                              | 'arrow'              |
| Busy system                                               | 'watch'              |
| Resizing an object from a top-left or bottom-right corner | 'topl' or 'botr'     |
| Resizing an object from a top-right or bottom-left corner | 'topr' or 'botl'     |
| A hot spot                                                | 'circle'             |
| A point                                                   | 'cross'              |
| Moving an object                                          | 'fleur'              |
| Resizing an object from the left or right                 | 'left' or 'right'    |
| Resizing an object from the top or bottom                 | 'top' or 'bottom'    |
| Aligning a point with other objects on the display        | 'fullcross'          |
| Clickable icon                                            | 'hand'               |

Setting `Pointer` to `custom` allows you to define your own pointer symbol. See the `PointerShapeCData` property for more information.

**PointerShapeCData**  
16-by-16 matrix

*User-defined pointer.* Defines the pointer used when you set the **Pointer** property to **custom**. It is a 16-by-16 element matrix defining the 16-by-16 pixel pointer using the following values:

- 1 — Color pixel black.
- 2 — Color pixel white.
- NaN — Make pixel transparent (underlying screen shows through).

Element (1,1) of the **PointerShapeCData** matrix corresponds to the upper-left corner of the pointer. Setting the **Pointer** property to one of the predefined pointer symbols does not change the value of the **PointerShapeCData**. Computer systems supporting 32-by-32 pixel pointers fill only one quarter of the available pixmap.

**PointerShapeHotSpot**  
two-element vector

*Pointer active area.* Specifies the row and column indices in the **PointerShapeCData** matrix defining the pixel indicating the pointer location. The location is contained in the **CurrentPoint** property and the root object's **PointerLocation** property. The default value is element (1,1), which is the upper-left corner.

**Position**  
four-element vector

*Figure position.* Specifies the size and location on the screen of the figure window, not including title bar, menu bar, tool bars, and outer edges. Specify the position rectangle with a four-element vector of the form:

```
rect = [left, bottom, width, height]
```

# Figure Properties

---

where `left` and `bottom` define the distance from the lower-left corner of the screen to the lower-left corner of the figure window. `width` and `height` define the dimensions of the window. See the `Units` property for information on the units used in this specification. The `left` and `bottom` elements can be negative on systems that have more than one monitor.

## Position of Docked Figures

If the figure is docked in the MATLAB desktop or in a figure window container, then the `Position` property is specified with respect to the figure group container instead of the screen.

## Moving and Resizing Figures

You can use the `get` function to obtain this property and determine the position of the figure and you can use the `set` function to resize and move the figure to a new location. You cannot set the figure `Position` when it is docked.

---

**Note** On Windows systems, figure windows cannot be less than 104 pixels wide, regardless of the value of the `Position` property.

Also, the figure window includes the area to which MATLAB can draw; it does not include the title bar, menu bar, tool bars, and outer edges. To place the full window, use the `OuterPosition` property.

---

Renderer

`painters` | `zbuffer` | `OpenGL`

*Rendering method used for screen and printing.* Selects the method used to render MATLAB graphics. `painters` is the default. The choices are:



- **painters** — The original rendering method used by MATLAB is faster when the figure contains only simple or small graphics objects.

If you set `Renderer` to `painters` on a Windows system, set `Colormap` no longer than 256 rows.

- **zbuffer** — MATLAB draws graphics objects faster and more accurately because it colors objects on a per-pixel basis and MATLAB renders only those pixels that are visible in the scene (thus eliminating front-to-back sorting errors). Note that this method can consume a lot of system memory if MATLAB is displaying a complex scene.
- **OpenGL** — OpenGL is a renderer that is available on many computer systems. This renderer is generally faster than `painters` or `zbuffer` and in some cases enables MATLAB to access graphics hardware that is available on some systems.

## Hardware vs. Software OpenGL Implementations

There are two kinds of OpenGL implementations — hardware and software.

The hardware implementation uses special graphics hardware to increase performance and is therefore significantly faster than the software version. Many computers have this special hardware available as an option or might come with this hardware right out of the box.

Software implementations of OpenGL are much like the `ZBuffer` renderer that is available on MATLAB Version 5.0 and later; however, OpenGL generally provides superior performance to `ZBuffer`.

## OpenGL Availability

# Figure Properties

---

OpenGL is available on all computers that run MATLAB. MATLAB automatically finds hardware-accelerated versions of OpenGL if such versions are available. If the hardware-accelerated version is not available, then MATLAB uses the software version (except on Macintosh systems, which do not support software OpenGL).

The following software versions are available:

- On UNIX systems, MATLAB uses the software version of OpenGL that is included in the MATLAB distribution.
- On Windows, OpenGL is available as part of the operating system. If you experience problems with OpenGL, contact your graphics driver vendor to obtain the latest qualified version of OpenGL.
- On Macintosh systems, software OpenGL is not available.

MATLAB issues a warning if it cannot find a usable OpenGL library.

## **Selecting Hardware-Accelerated or Software OpenGL**

MATLAB enables you to switch between hardware-accelerated and software OpenGL. However, Windows and UNIX systems behave differently:

- On Windows systems, you can toggle between software and hardware versions any time during the MATLAB session.
- On UNIX systems, you must set the OpenGL version before MATLAB initializes OpenGL. Therefore, you cannot issue the `opengl info` command or create graphs before you call `opengl software`. To reenabte hardware accelerated OpenGL, you must restart MATLAB.
- On Macintosh systems, software OpenGL is not available.

If you do not want to use hardware OpenGL, but do want to use object transparency, you can issue the following command.

```
opengl software
```

This command forces MATLAB to use software OpenGL. Software OpenGL is useful if your hardware-accelerated version of OpenGL does not function correctly and you want to use image, patch, or surface transparency, which requires the OpenGL renderer. To reenable hardware OpenGL, use the command:

```
opengl hardware
```

on Windows systems or restart MATLAB on UNIX systems.

By default, MATLAB uses hardware-accelerated OpenGL.

See the `opengl` reference page for additional information

### **Determining the OpenGL Library Version**

To determine the version and vendor of the OpenGL library that MATLAB is using on your system, type the following command at the MATLAB prompt:

```
opengl info
```

The returned information contains a line that indicates if MATLAB is using software (`Software = true`) or hardware-accelerated (`Software = false`) OpenGL.

This command also returns a string of extensions to the OpenGL specification that are available with the particular library MATLAB is using. Include this information if you report a bug.

Note that issuing the `opengl info` command causes MATLAB to initialize OpenGL.

## OpenGL vs. Other MATLAB Renderers

There are some differences between drawings created with OpenGL and those created with other renderers. The OpenGL specific differences include:

- OpenGL does not do colormap interpolation. If you create a surface or patch using indexed color and interpolated face or edge coloring, OpenGL interpolates the colors through the RGB color cube instead of through the colormap.
- OpenGL does not support the `phong` value for the `FaceLighting` and `EdgeLighting` properties of surfaces and patches.
- OpenGL does not support logarithmic-scale axes.
- OpenGL and Zbuffer renderers display objects sorted in front to back order, as seen on the monitor, and lines always draw in front of faces when at the same location on the plane of the monitor. Painters sorts by child order (order specified).

## XServer Connection Lost

When using Linux or Macintosh systems, MATLAB can crash with a segmentation violation if the connection to the XServer is broken. If this occurs, ensure that the system has the latest XServer installed.

You can also try using software OpenGL and upgrade the OpenGL driver on a Linux system.

Try these workarounds:

- 1** Upgrade you XServer to the latest version
- 2** Upgrade your OpenGL driver to the latest version
- 3** Switch to software OpenGL by entering this command:

```
opengl software
```

RendererMode  
{auto} | manual

*Automatic or user selection of renderer.* Specifies whether MATLAB should choose the `Renderer` based on the contents of the figure window, or whether the `Renderer` should remain unchanged.

When the `RendererMode` property is `auto`, MATLAB selects the rendering method for printing as well as for screen display based on the size and complexity of the graphics objects in the figure.

For printing, MATLAB switches to `zbuffer` at a greater scene complexity than for screen rendering because printing from a z-buffered figure can be considerably slower than one using the `painters` rendering method, and can result in large PostScript® files. However, the output does always match what is on the screen. The same holds true for OpenGL: the output is the same as that produced by the `zbuffer` renderer — a bitmap with a resolution determined by the `print` command's `-r` option.

### Criteria for Autoselection of the OpenGL Renderer

When the `RendererMode` property is `auto`, MATLAB uses the following criteria to determine whether to select the OpenGL renderer:

If the `opengl` autoselection mode is `autoselect`, MATLAB selects OpenGL if

- The host computer has OpenGL installed and is in True Color mode (OpenGL does not fully support 8-bit color mode).
- The figure contains no logarithmic axes (OpenGL does not support logarithmic axes).
- MATLAB would select `zbuffer` based on figure contents.

# Figure Properties

---

- Patch objects' faces have no more than three vertices (some OpenGL implementations of patch tessellation are unstable).
- The figure contains less than 10 uicontrols (OpenGL clipping around uicontrols is slow).
- No line objects use markers (drawing markers is slow).
- You do not specify Phong lighting (OpenGL does not support Phong lighting; if you specify Phong lighting, MATLAB uses the ZBuffer renderer).

Or

- Figure objects use transparency (OpenGL is the only MATLAB renderer that supports transparency).

When the `RendererMode` property is `manual`, MATLAB does not change the `Renderer`, regardless of changes to the figure contents.

## Resize

{on} | off

*Window resize mode.* Determines if you can resize the figure window with the mouse. `on` means you can resize the window, `off` means you cannot. When `Resize` is `off`, the figure window does not display any resizing controls (such as boxes at the corners), to indicate that it cannot be resized.

## ResizeFcn

function handle | cell array containing function handle and additional arguments | string (not recommended)

*Window resize callback function.* Executes whenever you resize the figure window and when the figure is created. You can query the figure's `Position` property to determine the new size and position of the figure. During execution of the callback routine, the handle to the figure being resized is accessible only through the root `CallbackObject` property, which you can query using `gcbo`.

You can use `ResizeFcn` to maintain a GUI layout that is not directly supported by the MATLAB Position/Units paradigm.

For example, consider a GUI layout that maintains an object at a constant height in pixels and attached to the top of the figure, but always matches the width of the figure. The following `ResizeFcn` accomplishes this; it keeps the `uicontrol` whose `Tag` is `'StatusBar'` 20 pixels high, as wide as the figure, and attached to the top of the figure. Note the use of the `Tag` property to retrieve the `uicontrol` handle, and the `gcbo` function to retrieve the figure handle. Also note the defensive programming regarding figure `Units`, which the callback requires to be in pixels in order to work correctly, but which the callback also restores to their previous value afterwards.

```
u = findobj('Tag','StatusBar');
fig = gcbo;
old_units = get(fig,'Units');
set(fig,'Units','pixels');
figpos = get(fig,'Position');
upos = [0, figpos(4) - 20, figpos(3), 20];
set(u,'Position',upos);
set(fig,'Units',old_units);
```

You can change the figure `Position` from within the `ResizeFcn` callback; however, the `ResizeFcn` is not called again as a result.

Note that the `print` command can cause the `ResizeFcn` to be called if the `PaperPositionMode` property is `manual` and you have defined a `ResizeFcn` function. If you do not want `ResizeFcn` called by `print`, set the `PaperPositionMode` to `auto`.

See “Function Handle Callbacks” for information on how to use function handles to define the callback function.

Selected  
on | off

# Figure Properties

---

*Is object selected?* This property indicates whether the figure is selected. You can, for example, define the `ButtonDownFcn` to set this property, allowing users to select the object with the mouse.

`SelectionHighlight`  
{on} | off

Figures do not indicate selection.

`SelectionType`  
{normal} | extend | alt | open

*Mouse selection type.* MATLAB maintains this property to provide information about the last mouse button press that occurred within the figure window. This information indicates the type of selection made. Selection types are actions that MATLAB generally associates with particular responses from the user interface software (for example, single-clicking a graphics object places it in move or resize mode; double-clicking a file name opens it, etc.).

The physical action required to make these selections varies on different platforms. However, all selection types exist on all platforms.

| <b>Selection Type</b> | <b>Microsoft Windows</b>                                                           | <b>X-Windows</b>                                                    |
|-----------------------|------------------------------------------------------------------------------------|---------------------------------------------------------------------|
| Normal                | Click left mouse button.                                                           | Click left mouse button.                                            |
| Extend                | <b>Shift</b> - click left mouse button or click both left and right mouse buttons. | <b>Shift</b> -click left mouse button or click middle mouse button. |



| Selection Type | Microsoft Windows                                                     | X-Windows                                                            |
|----------------|-----------------------------------------------------------------------|----------------------------------------------------------------------|
| Alternate      | <b>Control</b> - click left mouse button or click right mouse button. | <b>Control</b> -click left mouse button or click right mouse button. |
| Open           | Double-click any mouse button.                                        | Double-click any mouse button.                                       |

**Note** For uicontrols whose Enable property is on, a single left-click, **Ctrl**-left click, or **Shift**-left click sets the figure SelectionType property to normal. For a list box uicontrol whose Enable property is on, the second click of a double-click sets the figure SelectionType property to open. All clicks on uicontrols whose Enable property is inactive or off and all right-clicks on uicontrols whose Enable property is on set the figure SelectionType property as specified in the preceding table.

Tag

string

*User-specified object label.* Provides a means to identify graphics objects with a user-specified label. The default is an empty string.

Use the Tag property and the findobj function to manipulate specific objects within a plotting hierarchy.

For example, suppose you want to direct all graphics output from a file to a particular figure, regardless of user actions that might have changed the current figure. To do this, identify the figure with a Tag.

```
figure('Tag','Plotting Figure')
```

# Figure Properties

---

Then make that figure the current figure before drawing by searching for the Tag with `findobj`.

```
figure(findobj('Tag','Plotting Figure'))
```

## Toolbar

none | {auto} | figure

*Control display of figure toolbar.* Control whether MATLAB displays the default figure toolbar on figures. The possible values are:

- none — Do not display the figure toolbar.
- auto — Display the figure toolbar, but remove it if a uicontrol is added to the figure.
- figure — Display the figure toolbar.

Note that this property affects only the figure toolbar; it does not affect other toolbars (for example, the Camera Toolbar or Plot Edit Toolbar). Selecting **Figure Toolbar** from the figure **View** menu sets this property to `figure`.

Changing the `WindowStyle` of a window to `'modal'` hides both its toolbar and menu bar, if they exist. Changing `WindowStyle` from `'modal'` to `'normal'` or `'docked'` displays any toolbar or menu bar a figure has.

## Type

string (read-only)

*Object class.* String that identifies the class of the graphics object. Use this property to find all objects of a given type within a plotting hierarchy. For figures, `Type` is always `'figure'`.

## UIContextMenu

handle of uicontextmenu object

*Associate a context menu with the figure.* Assign the handle of a `uicontextmenu` object created in the figure to this property. Use the `uicontextmenu` function to create the context menu. MATLAB displays the context menu whenever you right-click over the figure.

## Units

inches | centimeters | normalized | points | {pixels}  
| characters

*Units of measurement.* Specifies the units MATLAB uses to interpret size and location data. All units are measured from the lower-left corner of the window.

- `normalized` — Units map the lower-left corner of the figure window to (0,0) and the upper-right corner to (1.0,1.0).
- `inches`, `centimeters`, and `points` — Absolute units. 1 point =  $\frac{1}{72}$  inch.
- `pixels` — Size depends on screen resolution.
- `characters` — Based on the size of characters in the default system font. The width of one `characters` unit is the width of the letter `x`, and the height of one `characters` unit is the distance between the baselines of two lines of text.

This property affects the `CurrentPoint` and `Position` properties. If you change the value of `Units`, it is good practice to return it to its default value after completing your computation so as not to affect other functions that assume `Units` is the default value.

When specifying the units as property/value pairs during object creation, you must set the `Units` property before specifying the properties that you want to use these units.

## UserData

matrix

# Figure Properties

---

*User-specified data.* Data you want to associate with the figure object. The default value is an empty array. MATLAB does not use this data, but you can access it using the `set` and `get` commands.

`Visible`

`{on} | off`

*Object visibility.* The `Visible` property determines whether an object is displayed on the screen. If the `Visible` property of a figure is `off`, the entire figure window is invisible.

## A Note About Using the Window Button Properties

Your window button callback functions might need to update the display by calling `drawnow` or `pause`, which causes MATLAB to process all events in the queue. Processing the event queue can cause your window button callback functions to be reentered. For example, a `drawnow` in the `WindowButtonDownFcn` might result in the `WindowButtonDownFcn` being called again before the first call has finished. You should design your code to handle reentrancy and you should not depend on global variables that might change state during reentrance.

You can use the `Interruptible` and `BusyAction` figure properties to control how events interact.

`WindowButtonDownFcn`

function handle | cell array containing function handle and additional arguments | string (not recommended)

*Button press callback function.* Executes whenever you press a mouse button while the pointer is in the figure window. See the `WindowButtonMotionFcn` property for an example.

---

**Note** When using a two- or three-button mouse on Macintosh systems, right-button and middle-button presses are not always reported. This happens *only* when a new figure window appears under the mouse cursor and the mouse is clicked without first moving it. In this circumstance, for the `WindowButtonDownFcn` to work, the user needs to do one of the following:

- Move the mouse after the figure is created, then click any mouse button
- Press **Shift** or **Ctrl** while clicking the left mouse button to perform the Extend and Alternate selection types

Pressing the left mouse button (or single mouse button) works without having to take either of the above actions.

---

See “Function Handle Callbacks” for information on how to use function handles to define the callback function.

## `WindowButtonMotionFcn`

function handle | cell array containing function handle and additional arguments | string (not recommended)

*Mouse motion callback function.* Executes whenever you move the pointer within the figure window. Define the `WindowButtonMotionFcn` as a function handle. The function must define at least two input arguments (handle of figure associated with key release and an event structure).

See “Function Handle Callbacks” for information on how to use function handles to define the callback function.

## Example Using All Window Button Properties

Click to view in editor — This example enables you to use mouse motion to draw lines. It uses all three window button functions.

# Figure Properties

---

Click to run example — Click the left mouse button in the axes and move the cursor, left-click to define the line end point, right-click to end drawing mode.

---

**Note** On some computer systems, the `WindowButtonMotionFcn` is executed when a figure is created even though there has been no mouse motion within the figure.

---

## `WindowButtonUpFcn`

function handle | cell array containing function handle and additional arguments | string (not recommended)

*Button release callback function.* Executes whenever you release a mouse button. Define the `WindowButtonUpFcn` as a function handle. The function must define at least two input arguments (handle of figure associated with key release and an event structure).

The button up event is associated with the figure window in which the preceding button down event occurred. Therefore, the pointer need not be in the figure window when you release the button to generate the button up event.

If the callback routines defined by `WindowButtonDownFcn` or `WindowButtonMotionFcn` contain `drawnow` commands or call other functions that contain `drawnow` commands and the `Interruptible` property is off, the `WindowButtonUpFcn` might not be called. You can prevent this problem by setting `Interruptible` to on.

See “Function Handle Callbacks” for information on how to use function handles to define the callback function.

## `WindowKeyPressFcn`

function handle | cell array containing function handle and additional arguments | string (not recommended)

*Key press callback function for the figure window.* Executes whenever a key press occurs. This is a callback function invoked by a key press that occurs while either the figure window or any of its children has focus. Define the `WindowKeyPressFcn` as a function handle. The function must define at least two input arguments (handle of figure associated with key release and an event structure).

For information on the syntax of callback functions, see [Function Handle Callbacks](#).

When no callback is specified for this property (which is the default state), MATLAB passes any key presses to the Command Window. However, when you define a callback for this property, the figure retains focus with each key press and executes the specified callback with each key press.

## WindowKeyPressFcn Event Structure

When you specify the callback as a function handle, MATLAB passes to it a structure to containing the following fields.

| Field     | Contents                                                                                                                                                                                                                        |
|-----------|---------------------------------------------------------------------------------------------------------------------------------------------------------------------------------------------------------------------------------|
| Character | The character displayed as a result of the releasing the key(s), which can be empty or unprintable                                                                                                                              |
| Key       | The key being released, identified by the lowercase label on key or a descriptive string                                                                                                                                        |
| Modifier  | A cell array containing the names of one or more modifier keys being released (i.e., <b>control</b> , <b>alt</b> , <b>shift</b> ). On Macintosh computers, it contains 'command' when releasing the <b>command</b> modifier key |

For more information and examples of use, see the `KeyPressFcn` property description.

## WindowKeyReleaseFcn

function handle | cell array containing function handle and additional arguments | string (not recommended)

*Key release callback function for the figure window.* Executes whenever a key release occurs. This is a callback function invoked by a key release that occurs while the figure window or any of its children has focus. Define the `WindowKeyReleaseFcn` as a function handle. The function must define at least two input arguments (handle of the figure associated with key release and an event structure).

See “Function Handle Callbacks” for information on how to use function handles to define the callback function.



## WindowKeyReleaseFcn Event Structure

When you specify the callback as a function handle, MATLAB passes to it a structure to containing the following fields.

| Field     | Contents                                                                                                                                                                                                                        |
|-----------|---------------------------------------------------------------------------------------------------------------------------------------------------------------------------------------------------------------------------------|
| Character | The character displayed as a result of the releasing the key(s), which can be empty or unprintable                                                                                                                              |
| Key       | The key being released, identified by the lowercase label on key or a descriptive string                                                                                                                                        |
| Modifier  | A cell array containing the names of one or more modifier keys being released (i.e., <b>control</b> , <b>alt</b> , <b>shift</b> ). On Macintosh computers, it contains 'command' when releasing the <b>command</b> modifier key |

For more information and examples of use, see the `KeyReleaseFcn` property description.

### WindowScrollWheelFcn

function handle | cell array containing function handle and additional arguments | string (not recommended)

*Respond to mouse scroll wheel.* Executes when the mouse wheel is scrolled while the figure has focus. MATLAB executes the callback with each single mouse wheel click.

Note that it is possible for another object to capture the event from MATLAB. For example, if the figure contains Java or ActiveX control objects that are listening for mouse scroll wheel events, then these objects can consume the events and prevent the `WindowScrollWheelFcn` from executing.

There is no default callback defined for this property.

# Figure Properties

---

## WindowScrollWheelFcn Event Structure

When the callback is a function handle, MATLAB passes a structure to the callback function that contains the following fields.

| Field                | Contents                                                                                                                                                                                                                                                   |
|----------------------|------------------------------------------------------------------------------------------------------------------------------------------------------------------------------------------------------------------------------------------------------------|
| VerticalScrollCount  | A positive or negative integer that indicates the number of scroll wheel clicks. Positive values indicate clicks of the wheel scrolled in the down direction. Negative values indicate clicks of the wheel scrolled in the up direction.                   |
| VerticalScrollAmount | The current system setting for the number of lines that are scrolled for each click of the scroll wheel. If the mouse property setting for scrolling is set to <code>One screen at a time</code> , <code>VerticalScrollAmount</code> returns a value of 1. |

## Effects on Other Properties

- **CurrentObject** property — Mouse scrolling does not update this figure property.
- **CurrentPoint** property — If there is no callback defined for the **WindowScrollWheelFcn** property, then MATLAB does not update the **CurrentPoint** property as the scroll wheel is turned. However, if there is a callback defined for the **WindowScrollWheelFcn** property, then MATLAB updates the **CurrentPoint** property just before executing the callback. This enables you to determine the point at which the mouse scrolling occurred.
- **HitTest** property — The **WindowScrollWheelFcn** callback executes regardless of the setting of the figure **HitTest** property.
- **SelectionType** property — The **WindowScrollWheelFcn** callback has no effect on this property.

## Values Returned by VerticalScrollCount

When a user moves the mouse scroll wheel by one click, MATLAB increments the count by +/- 1, depending on the direction of the scroll (scroll down being positive). When MATLAB calls the **WindowScrollWheelFcn** callback, the counter is reset. In most cases, this means that the absolute value of the returned value is 1. However, if the **WindowScrollWheelFcn** callback takes a long enough time to return and/or the user spins the scroll wheel very fast, then the returned value can have an absolute value greater than one.

The actual value returned by **VerticalScrollCount** is the algebraic sum of all scroll wheel clicks that occurred since last processed. This enables your callback to respond correctly to the user's action.

## Example

# Figure Properties

---

Click to view in editor — This example creates a graph of a function and enables you to use the mouse scroll wheel to change the range over which a mathematical function is evaluated and update the graph to reflect the new limits as you turn the scroll wheel.

Click to run example — Mouse over the figure and scroll your mouse wheel.

## Related Information

See “Function Handle Callbacks” for information on how to use function handles to define the callback function.

`WindowState`  
{normal} | modal | docked

*Normal, modal, or dockable window behavior.* When `WindowState` is `modal`:

- The figure window traps all keyboard and mouse events over all MATLAB windows as long as they are visible.
- Windows belonging to applications other than MATLAB are unaffected.
- Modal figures remain stacked above all normal figures and the MATLAB Command Window.
- When multiple modal windows exist, the most recently created window keeps focus and stays above all other windows until it becomes invisible, or is returned to `WindowState normal`, or is deleted. At that time, focus reverts to the window that last had focus.

Use modal figures to create dialog boxes that force the user to respond without being able to interact with other windows. Typing **Ctrl+C** while the figure has focus causes all figures with

`WindowState modal` to revert to `WindowState normal`, allowing you to type at the command line.

## Invisible Modal Figures

Figures with `WindowState modal` and `Visible off` do not behave modally until they are made visible, so it is acceptable to hide a modal window for later reuse instead of destroying it.

## Stacking Order of Modal Figures

Creating a figure with `WindowState modal` stacks it on top of all existing figure windows, making them inaccessible as long as the top figure exists and remains modal. However, any new figures created after a modal figure is displayed (for example, plots created by a modal GUI) stack on top of it and are accessible; they can be modal as well.

## Changing Modes

You can change the `WindowState` of a figure at any time, including when the figure is visible and contains children. However, on some systems this might cause the figure to flash or disappear and reappear, depending on the windowing system's implementation of normal and modal windows. For best visual results, you should set `WindowState` at creation time or when the figure is invisible.

## Window Decorations on Modal Figures

Modal figures do not display `uimenu` children, built-in menus, or toolbars but it is not an error to create `uimenu`s in a modal figure or to change `WindowState` to `modal` on a figure with `uimenu` children. The `uimenu` objects exist and their handles are retained by the figure. If you reset the figure's `WindowState` to `normal`, the `uimenu`s are displayed.

## Docked WindowStyle

# Figure Properties

---

When `WindowState` is `docked`, the figure is docked in the desktop or a document window. When you issue the following command:

```
set(figure_handle, 'WindowState', 'docked')
```

MATLAB docks the figure identified by *figure\_handle* and sets the `DockControls` property to `on`, if it was `off`.

Note that if `WindowState` is `docked`, you cannot set the `DockControls` property to `off`.

The value of the `WindowState` property is not changed by calling `reset` on a figure.

## WVisual

identifier string (Windows only)

*Specify pixel format for figure.* MATLAB automatically selects a pixel format for figures based on your current display settings, the graphics hardware available on your system, and the graphical content of the figure.

Usually, MATLAB chooses the best pixel format to use in any given situation. However, in cases where graphics objects are not rendered correctly, you might be able to select a different pixel format and improve results. See “Understanding the WVisual String” for more information.

## Querying Available Pixel Formats on Window Systems

You can determine what pixel formats are available on your system for use with MATLAB using the following statement:

```
set(gcf, 'WVisual')
```

MATLAB returns a list of the currently available pixel formats for the current figure. For example, the following are the first three entries from a typical list:

01 (RGB 16 bits(05 06 05 00) zdepth 24, Hardware Accelerated, OpenGL, GDI, Window)

02 (RGB 16 bits(05 06 05 00) zdepth 24, Hardware Accelerated, OpenGL, Double Buffered, Window)

03 (RGB 16 bits(05 06 05 00) zdepth 24, Hardware Accelerated, OpenGL, Double Buffered, Window)

Use the number at the beginning of the string to specify which pixel format to use. For example:

```
set(gcf, 'WVisual', '02')
```

specifies the second pixel format in the list above. Note that pixel formats might differ on your system.

## Understanding the WVisual String

The string returned by querying the `WVisual` property provides information on the pixel format. For example:

- `RGB 16 bits(05 06 05 00)` — Indicates true color with 16-bit resolution (5 bits for red, 6 bits for green, 5 bits for blue, and 0 for alpha (transparency). MATLAB requires true color.
- `zdepth 24` — Indicates 24-bit resolution for sorting object's front to back position on the screen. Selecting pixel formats with higher (24 or 32) zdepth might solve sorting problems.
- `Hardware Accelerated` — Some graphics functions might be performed by hardware for increased speed. If there are incompatibilities between your particular graphic hardware and MATLAB, select a pixel format in which the term `Generic` appears instead of `Hardware Accelerated`.
- `Opengl` — Supports OpenGL. See the preceding “Pixel Formats and OpenGL” for more information.
- `GDI` — Supports for Windows 2-D graphics interface.

# Figure Properties

---

- **Double Buffered** — Support for double buffering with the OpenGL renderer. Note that the figure `DoubleBuffer` property applies only to the painters renderer.
- **Bitmap** — Support for rendering into a bitmap (as opposed to drawing in the window).
- **Window** — Support for rendering into a window.

## Pixel Formats and OpenGL

If you are experiencing problems using hardware OpenGL on your system, you can try using generic OpenGL, which is implemented in software. To do this, first instruct MATLAB to use the software version of OpenGL with the following statement:

```
opengl software
```

Then allow MATLAB to select best pixel format to use.

See the `Renderer` property for more information on how MATLAB uses OpenGL.

`WVisualMode`  
{auto} | manual (Windows only)

*Auto or manual selection of pixel format.* `WVisualMode` can take on two values — `auto` (the default) and `manual`. In `auto` mode, MATLAB selects the best pixel format to use based on your computer system and the graphical content of the figure. In `manual` mode, MATLAB does not change the visual from the one currently in use. Setting the `WVisual` property sets this property to `manual`.

`XDisplay`  
display identifier (UNIX only)

*Contains the display used for MATLAB.* You can query this property to determine the name of the display that MATLAB is



using. For example, if MATLAB is running on a system called `mycomputer`, querying `XDisplay` returns a string of the following form:

```
get(gcf, 'XDisplay')
ans
mycomputer:0.0
```

## Setting XDisplay on Motif

If your computer uses Motif-based figures, you can specify the display MATLAB uses for a figure by setting the value of the figure's `XDisplay` property. For example, to display the current figure on a system called `fred`, use the command:

```
set(gcf, 'XDisplay', 'fred:0.0')
```

## XVisual

visual identifier (UNIX only)

*Select visual used by MATLAB.* You can select the visual used by MATLAB by setting the `XVisual` property to the desired visual ID. This can be useful if you want to test your application on an 8-bit or grayscale visual. To see what visuals are available on your system, use the UNIX `xdpyinfo` command. From MATLAB, type:

```
!xdpyinfo
```

The information returned contains a line specifying the visual ID. For example:

```
visual id: 0x23
```

To use this visual with the current figure, set the `XVisual` property to the ID.

```
set(gcf, 'XVisual', '0x23')
```

# Figure Properties

---

To see which of the available visuals MATLAB can use, call `set` on the `XVisual` property:

```
set(gcf, 'XVisual')
```

The following typical output shows the visual being used (in curly braces) and other possible visuals. Note that MATLAB requires a `TrueColor` visual.

```
{ 0x23 (TrueColor, depth 24, RGB mask 0xff0000 0xff00 0x00ff) }
 0x24 (TrueColor, depth 24, RGB mask 0xff0000 0xff00 0x00ff)
 0x25 (TrueColor, depth 24, RGB mask 0xff0000 0xff00 0x00ff)
 0x26 (TrueColor, depth 24, RGB mask 0xff0000 0xff00 0x00ff)
 0x27 (TrueColor, depth 24, RGB mask 0xff0000 0xff00 0x00ff)
 0x28 (TrueColor, depth 24, RGB mask 0xff0000 0xff00 0x00ff)
 0x29 (TrueColor, depth 24, RGB mask 0xff0000 0xff00 0x00ff)
 0x2a (TrueColor, depth 24, RGB mask 0xff0000 0xff00 0x00ff)
```

You can also use the `glxinfo` UNIX command to see what visuals are available for use with the OpenGL renderer. From MATLAB, type:

```
!glxinfo
```

After providing information about the implementation of OpenGL on your system, `glxinfo` returns a table of visuals. The partial listing below shows typical output:

```
visual x bf lv rg d st colorbuffer ax dp st accumbuffer ms cav
id dep cl sp sz l ci b ro r g b a bf th cl r g b a ns b eat

-
0x23 24 tc 0 24 0 r y . 8 8 8 8 0 0 0 0 0 0 0 0 0 0 0 0 0 0 None
0x24 24 tc 0 24 0 r . . 8 8 8 8 0 0 0 0 0 0 0 0 0 0 0 0 None
0x25 24 tc 0 24 0 r y . 8 8 8 8 0 24 8 0 0 0 0 0 0 0 0 0 None
0x26 24 tc 0 24 0 r . . 8 8 8 8 0 24 8 0 0 0 0 0 0 0 0 0 None
0x27 24 tc 0 24 0 r y . 8 8 8 8 0 0 0 0 0 16 16 16 0 0 0 Slow
```

The third column is the class of visual. `tc` means a true color visual. Note that some visuals might be labeled `Slow` under the caveat column. Such visuals should be avoided.

To determine which visual MATLAB will use by default with the OpenGL renderer, use the MATLAB `opengl info` command. The returned entry for the visual might look like the following:

```
Visual = 0x23 (TrueColor, depth 24, RGB mask 0xff0000 0xff00 0x00ff)
```

Experimenting with a different TrueColor visual might improve certain rendering problems.

`XVisualMode`  
{auto} | manual (UNIX only)

*Auto or manual selection of visual.* `XVisualMode` can take on two values — `auto` (the default) and `manual`. In `auto` mode, MATLAB selects the best visual to use based on the number of colors, availability of the OpenGL extension, etc. In `manual` mode, MATLAB does not change the visual from the one currently in use. Setting the `XVisual` property sets this property to `manual`.

## See Also

`figure`

# figurepalette

---

**Purpose** Show or hide **Figure Palette**

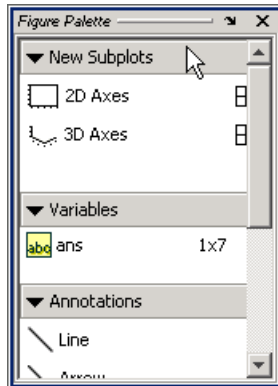

**Syntax**

```
figurepalette('show')
figurepalette('hide')
figurepalette
figurepalette(figure_handle,...)
```

**Description**

figurepalette('show') displays the palette on the current figure.

figurepalette('hide') hides the palette on the current figure.

figurepalette toggles the visibility of the palette on the current figure. You can also use figurepalette('toggle') instead for the same functionality.

figurepalette(figure\_handle,...) shows or hides the palette on the figure specified by figure\_handle.

**Tips**

If you call figurepalette in a MATLAB program and subsequent lines depend on the Figure Palette being fully initialized, follow it by drawnow to ensure complete initialization.

**Alternatives**

To collectively enable **Plotting Tools**, use the large Plotting Tool icon  on the figure toolbar. To collectively disable the **Plotting Tools**,

use the smaller icon . Open or close the **Figure Palette** tool from the figure's **View** menu.

## See Also

[plottools](#) | [plotbrowser](#) | [propertyeditor](#)

# fileattrib

---

**Purpose** Set or get attributes of file or folder

**Syntax**

```
fileattrib
fileattrib(name)

fileattrib(name,attribs)
fileattrib(name,attribs,users)
fileattrib(name,attribs,users,'s')

[status,message,messageid] = fileattrib(name,attribs, ___)
[status,message] = fileattrib(name)
```

**Description** fileattrib gets attribute values for the current folder, using the following structure, where Name is always a string containing the current folder name. For the other fields, a value of 0 indicates that the attribute is off, 1 indicates that the attribute is on, and NaN indicates that the attribute does not apply:

```
Name
archive
system
hidden
directory
UserRead
UserWrite
UserExecute
GroupRead
GroupWrite
GroupExecute
OtherRead
```

fileattrib(name) gets the attribute values for the named file or folder.

`fileattrib(name,attribs)` sets the specified attributes for the named file or folder.

`fileattrib(name,attribs,users)` sets the file or folder attributes for the specified subset of users.

`fileattrib(name,attribs,users,'s')` sets the specified attributes for the specified users for the contents of the named folder.

`[status,message,messageid] = fileattrib(name,attribs, __)` sets the specified file attributes and gets the function status:

- If `status` is 0, then `message` is the error message, and `messageid` is the error message identifier.
- If `status` is 1, then `message` is a structure containing the attributes of the named file or folder, and `messageid` is an empty string.

`[status,message] = fileattrib(name)` gets `status` and the last *successfully* set attribute structure values for the named file or folder and returns the structure to `message`. (`status` is always 1.)

## Input Arguments

### **name - File or folder name**

string

The absolute or relative path for a folder or file, specified as a string. To specify all names beginning with certain characters, add the wildcard character, `*`.

**Example:** `fileattrib('myfile.m')`

### **attribs - File or folder attribute values**

'a' | 'h' | 's' | 'w' | 'x'

File or folder attribute values, specified as a space delimited string. Use the plus (+) qualifier before an attribute to set it, and the minus (-) qualifier before an attribute to clear it.

# fileattrib

| attribvalue | Description                                                                                                                                                                                                                                                                         |
|-------------|-------------------------------------------------------------------------------------------------------------------------------------------------------------------------------------------------------------------------------------------------------------------------------------|
| 'a'         | Archive (Microsoft Windows platform only).                                                                                                                                                                                                                                          |
| 'h'         | Hidden file (Windows platform only).                                                                                                                                                                                                                                                |
| 's'         | System file (Windows platform only).                                                                                                                                                                                                                                                |
| 'w'         | Write access (Windows and UNIX platforms). Results differ by platform and application. For example, even though <code>fileattrib</code> disables the “write” privilege for a folder, making it read only, files in the folder could be writable for some platforms or applications. |
| 'x'         | Executable (UNIX platform only).                                                                                                                                                                                                                                                    |

**Example:** `fileattrib('myfile.m', '+w -h')`

## users - Subset of users

'a' | 'g' | 'o' | 'u' | ''

Subset of users (on UNIX platforms only), specified as a string. For all platforms other than UNIX, specify the `users` argument as an empty string, ''. This value is not returned by `fileattrib` get operations.

| Value for UNIX Users | Description                 |
|----------------------|-----------------------------|
| 'a'                  | All users on UNIX platforms |
| 'g'                  | Group of users              |
| 'o'                  | All other users             |
| 'u'                  | Current user                |

**Example:** `fileattrib('D:/work/results', '-w', 'a')`

## Output Arguments

### status - Indication of whether attempt to set attribute was successful

0 | 1



If attempt to set attribute was unsuccessful, status is 0. Otherwise, status is 1.

### message - Attribute structure or error message

string | structure array

Attribute structure or error message, depending on whether you are setting or getting attributes and status.

| Getting or Setting Attributes | Status | Message contents                                |
|-------------------------------|--------|-------------------------------------------------|
| Setting                       | 0      | Error message                                   |
| Setting                       | 1      | Empty string                                    |
| Getting                       | 1      | Structure containing file attributes and values |

When you are getting file attributes, the structure contains these fields and possible values.

| Field name  | Possible Values                               |
|-------------|-----------------------------------------------|
| Name        | String containing name of file or folder      |
| archive     | 0 (not set), 1 (set), or NaN (not applicable) |
| system      | 0, 1, or NaN                                  |
| hidden      | 0, 1, or NaN                                  |
| directory   | 0, 1, or NaN                                  |
| UserRead    | 0, 1, or NaN                                  |
| UserWrite   | 0, 1, or NaN                                  |
| UserExecute | 0, 1, or NaN                                  |
| GroupRead   | 0, 1, or NaN                                  |

# fileattrib

---

| Field name   | Possible Values |
|--------------|-----------------|
| GroupWrite   | 0, 1, or NaN    |
| GroupExecute | 0, 1, or NaN    |
| OtherRead    | 0, 1, or NaN    |
| OtherWrite   | 0, 1, or NaN    |
| OtherExecute | 0, 1, or NaN    |

## messageid - Error message identifier

string

Error message identifier when the attempt to set attribute is unsuccessful (`status` is 0), returned as a string. If `status` is 1, then `messageid` is an empty string.

## Tips

- `fileattrib` is like the DOS `attrib` command, or the UNIX `chmod` command. <sup>2</sup>

## Examples

### View Current Folder Attributes

View attributes of the current folder, assuming the current folder is `C:\my_MATLAB_files`.

```
fileattrib
```

```
ans =
```

```
 Name: 'C:\my_MATLAB_files'
 archive: 0
 system: 0
 hidden: 0
directory: 1
 UserRead: 1
```

2. UNIX is a registered trademark of The Open Group in the United States and other countries.

```
UserWrite: 1
UserExecute: 1
GroupRead: NaN
GroupWrite: NaN
GroupExecute: NaN
OtherRead: NaN
OtherWrite: NaN
OtherExecute: NaN
```

The attributes indicate that you have read, write, and execute permissions for the current folder.

### View File Attributes

View attributes of file `collatz.m`.

```
fileattrib('collatz.m')
```

```
ans =
```

```
Name: 'C:\my_MATLAB_files\collatz.m'
archive: 1
system: 0
hidden: 0
directory: 0
UserRead: 1
UserWrite: 0
UserExecute: 1
GroupRead: NaN
GroupWrite: NaN
GroupExecute: NaN
OtherRead: NaN
OtherWrite: NaN
OtherExecute: NaN
```

The attributes indicate that the specified item is a file. You can read and execute the file, but cannot update it. The file is archived.

## View Folder Attributes on a Windows System

View attributes for the folder C:\my\_MATLAB\_files\doc.

```
fileattrib('C:\my_MATLAB_files\doc')
```

```
ans =
```

```
 Name: 'C:\my_MATLAB_files\doc'
 archive: 0
 system: 0
 hidden: 0
 directory: 1
 UserRead: 1
 UserWrite: 1
 UserExecute: 1
 GroupRead: NaN
 GroupWrite: NaN
 GroupExecute: NaN
 OtherRead: NaN
 OtherWrite: NaN
 OtherExecute: NaN
```

The attributes indicate that you have read, write, and execute permissions for the specified folder.

## View Folder Attributes on a UNIX System

View attributes for the folder /public on a UNIX system.

```
fileattrib('/public')
```

```
ans =
```

```
 Name: '/public'
 archive: NaN
 system: NaN
 hidden: NaN
 directory: 1
```

```
UserRead: 1
UserWrite: 1
UserExecute: 1
GroupRead: 1
GroupWrite: 0
GroupExecute: 1
OtherRead: 1
OtherWrite: 0
OtherExecute: 1
```

The attributes indicate that you have read, write, and execute permissions for the specified folder. In addition, users in your UNIX group and all others have read and execute permissions for the specified folder, but not write permissions.

### Set File Attributes

Make `myfile.m` writeable.

```
fileattrib('myfile.m','+w')
```

### Set File Attributes for Specific Users on UNIX

Make the folder `/home/work/results` a read-only folder for *all users* on UNIX platforms.

```
fileattrib('/home/work/results','-w','a')
```

The minus (-) preceding the write attribute, `w`, removes the write status.

### Set Attributes for Folder and Its Contents

On Windows platforms, make the folder `D:\work\results` and all its contents read only and hidden.

```
fileattrib('D:\work\results','+h -w','','s')
```

Because a value for the `users` argument is not applicable on Windows systems, the argument is an empty string. The `s` argument applies the hidden and read-only attributes to the contents of the folder.

## Get Attributes Structure for a Folder

Get the attributes for the folder results and return them to a structure:

```
[stat, struc]=fileattrib('results')

stat =
 1

struc =
 Name: 'D:\work\results'
 archive: 0
 system: 0
 hidden: 0
 directory: 1
 UserRead: 1
 UserWrite: 1
 UserExecute: 1
 GroupRead: NaN
 GroupWrite: NaN
 GroupExecute: NaN
 OtherRead: NaN
 OtherWrite: NaN
 OtherExecute: NaN
```

The operation is successful as indicated by the status, `stat`, value of 1. The structure, `struc`, contains the file attributes.

Access the name attribute value in the structure. MATLAB returns the path for results.

```
struc.Name

ans =
D:\work\results
```

## Get Attributes Structure for Multiple Files

Get the attributes for all files in the current folder with names that begin with new.

```
[stat, struc]=fileattrib('new*')
```

```
stat =
 1
```

```
mess =
1x3 struct array with fields:
 Name
 archive
 system
 hidden
 directory
 UserRead
 UserWrite
 UserExecute
 GroupRead
 GroupWrite
 GroupExecute
 OtherRead
 OtherWrite
 OtherExecute
```

The results indicate there are three matching files.

View the file names.

```
struc.Name
```

```
ans =
D:\work\results\newname.m
```

```
ans =
D:\work\results\newone.m
```

# fileattrib

---

```
ans =
D:\work\results\newtest.m
```

View just the second file name.

```
struct(2).Name
```

```
ans =
D:\work\results\newname.m
```

## Successfully Set Attributes for a File and Get Messages

Show output that results when an attempt to set file attributes is successful.

```
[status,message,messageid] = fileattrib('C:/my_MATLAB_files\doc',...
'+h -w','','s')
```

```
status =
```

```
1
```

```
message =
```

```
''
```

```
messageid =
```

```
''
```

The `status` value of 1 indicates the set operation was successful; therefore, no error message or `messageid` is returned.



### Unsuccessfully Set Attributes for a File and Get Messages

Show output that results when an attempt to set file attributes is unsuccessful.

```
[status,message,messageid] = fileattrib('C:/my_MATLAB_files\doc',...
'+h w-', '', 's')
```

```
status =
```

```
 0
```

```
message =
```

```
Illegal file mode characters on the current platform.
```

```
messageid =
```

```
MATLAB:FILEATTRIB:ModeSyntaxError
```

The `status` value of 0 indicates the set operation was unsuccessful. The minus sign incorrectly appears after `w`, instead of before it.

### See Also

`cd` | `copyfile` | `delete` | `dir` | `ls` | `mkdir` | `movefile` | `rmdir`

# filebrowser

---

|                    |                                                                                                     |
|--------------------|-----------------------------------------------------------------------------------------------------|
| <b>Purpose</b>     | Open Current Folder browser, or select it if already open                                           |
| <b>Syntax</b>      | filebrowser                                                                                         |
| <b>Description</b> | filebrowser opens the Current Folder browser, or if it is already open, makes it the selected tool. |
| <b>See Also</b>    | cd   copyfile   fileattrib   ls   mkdir   movefile   pwd   rmdir                                    |
| <b>How To</b>      | <ul style="list-style-type: none"><li>• “Manage Files and Folders”</li></ul>                        |

- Purpose** Character to separate file name and internal function name
- Syntax** M = filemarker
- Description** M = filemarker returns the character that separates a file and a within-file function name.
- Examples** On the Microsoft Windows platform, for example, filemarker returns the '>' character:

```
filemarker
```

```
ans =
>
```

You can use the following command on any platform to get the help text for the local function pdeodes defined in pdepe.m:

```
helptext = help(['imwrite' filemarker 'validateSizes'])
```

```
helptext =
 How many bytes does each element occupy in memory?
```

You can use the filemarker character to indicate a location within a MATLAB program file where you want to set a breakpoint, for example. On all platforms, if you need to distinguish between two nested functions with the same name, use the forward slash (/) character to indicate the path to a particular instance of a function.

For instance, suppose myfile.m contains the following code:

```
function x = A(p1, p2)
...
 function y = B(p3)
 ...
 end
 function m = C(p4)
 ...
```

```
 end
 end

 function z = C(p5)
 ...
 function y = D(p6)
 ...
 end
 end
end
```

To indicate that you want to set a breakpoint at function `y` nested within function `x`, use the following command on the Windows platform:

```
dbstop myfile>x/y
```

To indicate that you want to set a breakpoint at function `m` nested within function `x` use the following command on the Windows platform:

```
dbstop myfile>m
```

In the first case, you specify `x/y` because `myfile.m` contains two nested functions named `y`. In the second case, there is no need to specify `x/m` because there is only one function `m` within `myfile.m`.

## See Also

`filesep`

**Purpose** Parts of file name and path

---

**Note** The fourth output argument of `fileparts` (file version) is no longer supported and has been removed. Calling the function with more than three output arguments generates an error.

---

**Syntax** `[pathstr,name,ext] = fileparts(filename)`

**Description** `[pathstr,name,ext] = fileparts(filename)` returns the path name, file name, and extension for the specified file. The file does not have to exist. `filename` is a string enclosed in single quotes. The returned `ext` field contains a dot (.) before the file extension.

### Tips

- `fileparts` only parses file names. It does not verify that a file or a folder exists.
- You can reconstruct the file from the parts using:

```
fullfile(pathstr,[name ext])
```

- On Microsoft Windows systems, you can use either forward (/) or back (\) slashes as path delimiters, even within the same string. On UNIX and Macintosh systems, use only / as a delimiter. You can use the `filesep` function to insert the correct separator character for the platform on which your code executes:

```
sep = filesep;
file = ['H:' sep 'user4' sep 'matlab' sep 'myfile.txt'];
```

```
file =
H:\user4\matlab\myfile.txt
```

- If the input consists of a folder name only, be sure that the right-most character is a delimiter (/ or \). Otherwise, `fileparts` parses the trailing portion of `filename` as the name of a file and returns it in `name` instead of in `pathstr`.

# fileparts

---

## Input Arguments

### **filename**

String containing a name of a file or folder, which can include a path and file extension. The function interprets all characters following the right-most delimiter as a file name plus extension.

## Output Arguments

### **pathstr**

String containing the part of `filename` interpreted as a path name

### **name**

String containing the name of the file without any extension

### **ext**

String containing the file extension only, beginning with a period (.)

## Definitions

### **Path Name**

The full or partial path to a destination folder location, always the initial portion of the filename string. Path names end with a slash character and, where appropriate, can begin with a drive letter. Windows paths use backward slashes (\). UNIX and Macintosh paths use forward slashes (/).

## Examples

Return the pieces of a file specification string to the separate string outputs `pathstr`, `name`, and `ext`. The full file specification is:

```
file = 'H:\user4\matlab\myfile.txt';
[pathstr,name,ext] = fileparts(file)
```

```
pathstr =
H:\user4\matlab
```

```
name =
myfile
```

```
ext =
```

.txt

---

Query parts of a user .cshrc file:

```
[pathstr,name,ext] = fileparts('/home/jsmith/.cshrc')
```

```
pathstr =
/home/jsmith
```

```
name =
 Empty string: 1-by-0
```

```
ext =
.cshrc
```

`fileparts` interprets the entire file name as an extension because it begins with a period.

## Alternatives

Use `uigetfile` to interactively select and return a file name and path, or `uigetdir` to interactively select and return a path name. If you call `fileparts` with the output of `uigetfile`, you can parse out the file name and extension.

## See Also

`filesep` | `fullfile` | `pathsep` | `uigetdir` | `uigetfile`

## Tutorials

- “Specify File Names”

# fileread

---

**Purpose** Read contents of file into string

**Syntax** `text = fileread(filename)`

**Description** `text = fileread(filename)` returns the contents of the file *filename* as a MATLAB string.

**Examples** Read and search the file `Contents.m` in the MATLAB `iofun` directory for the reference to `fileread`:

```
% find the correct directory and file
io_contents = ...
 fullfile(matlabroot, 'toolbox', 'matlab', 'iofun', 'Contents.m');

% read the file
filetext = fileread(io_contents);

% search for the line of code that includes 'fileread'
% each line is separated by a newline ('\n')

expr = '[^\n]*fileread[^\n]*';
fileread_info = regexp(filetext, expr, 'match');
```

**See Also** `fgetl` | `fgets` | `fscanf` | `fread` | `importdata` | `textscan` | `type`



**Purpose** File separator for current platform

**Syntax** `f = filesep`

**Description** `f = filesep` returns the platform-specific file separator character. The file separator is the character that separates individual folder and file names in a path string.

**Examples** Create a path to the `iofun` folder on a Microsoft Windows platform:

```
iofun_dir = ['toolbox' filesep 'matlab' filesep 'iofun']
```

```
iofun_dir =
 toolbox\matlab\iofun
```

# filesep

---

Create a path to `iofun` on a UNIX<sup>3</sup> platform.

```
iodir = ['toolbox' filesep 'matlab' filesep 'iofun']
```

```
iodir =
 toolbox/matlab/iofun
```

## See Also

[fullfile](#) | [fileparts](#) | [pathsep](#)

3. UNIX is a registered trademark of The Open Group in the United States and other countries.

**Purpose**

Filled 2-D polygons

**Syntax**

```
fill(X,Y,C)
fill(X,Y,ColorSpec)
fill(X1,Y1,C1,X2,Y2,C2,...)
fill(...,'PropertyName',PropertyValue)
h = fill(...)
```

**Description**

The `fill` function creates colored polygons.

`fill(X,Y,C)` creates filled polygons from the data in `X` and `Y` with vertex color specified by `C`. `C` is a vector or matrix used as an index into the colormap. If `C` is a row vector, `length(C)` must equal `size(X,2)` and `size(Y,2)`; if `C` is a column vector, `length(C)` must equal `size(X,1)` and `size(Y,1)`. If necessary, `fill` closes the polygon by connecting the last vertex to the first.

`fill(X,Y,ColorSpec)` fills two-dimensional polygons specified by `X` and `Y` with the color specified by `ColorSpec`.

`fill(X1,Y1,C1,X2,Y2,C2,...)` specifies multiple two-dimensional filled areas.

`fill(...,'PropertyName',PropertyValue)` allows you to specify property names and values for a patch graphics object.

`h = fill(...)` returns a vector of handles to patch graphics objects, one handle per patch object.

**Tips**

If `X` or `Y` is a matrix, and the other is a column vector with the same number of elements as rows in the matrix, `fill` replicates the column vector argument to produce a matrix of the required size. `fill` forms a vertex from corresponding elements in `X` and `Y` and creates one polygon from the data in each column.

The type of color shading depends on how you specify color in the argument list. If you specify color using `ColorSpec`, `fill` generates flat-shaded polygons by setting the patch object's `FaceColor` property to the corresponding RGB triple.

If you specify color using `C`, `fill` scales the elements of `C` by the values specified by the axes property `CLim`. After scaling `C`, `C` indexes the current colormap.

If `C` is a row vector, `fill` generates flat-shaded polygons where each element determines the color of the polygon defined by the respective column of the `X` and `Y` matrices. Each patch object's `FaceColor` property is set to `'flat'`. Each row element becomes the `CData` property value for the  $n$ th patch object, where  $n$  is the corresponding column in `X` or `Y`.

If `C` is a column vector or a matrix, `fill` uses a linear interpolation of the vertex colors to generate polygons with interpolated colors. It sets the patch graphics object `FaceColor` property to `'interp'` and the elements in one column become the `CData` property value for the respective patch object. If `C` is a column vector, `fill` replicates the column vector to produce the required sized matrix.

## Examples

### Create Red Octagon

Define the data.

```
t = (1/16:1/8:1)'*2*pi;
x = sin(t);
y = cos(t);
```

Create a red octagon using the `fill` function.

```
fill(x,y,'r')
axis square
```

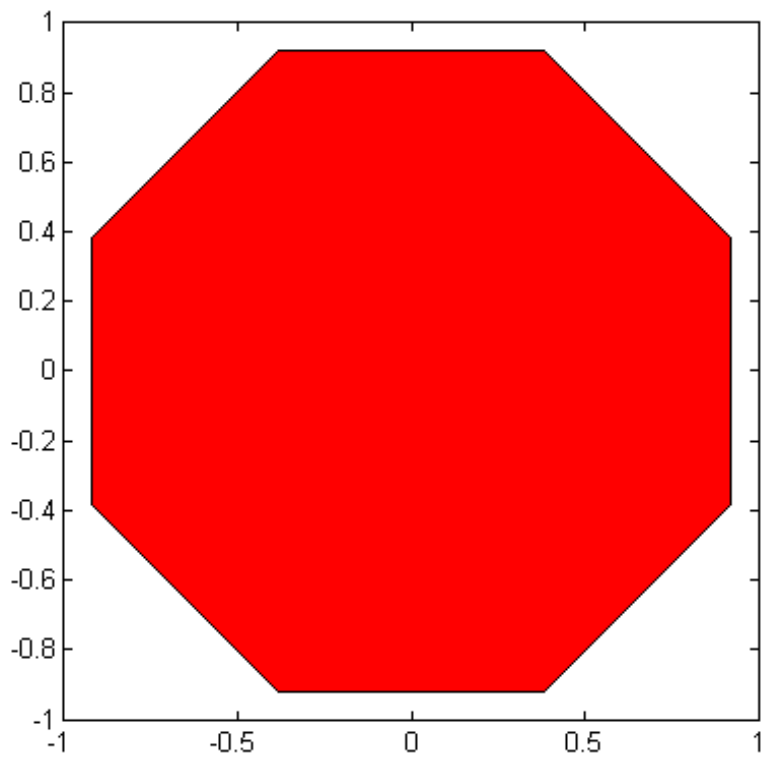
**See Also**

[axis](#) | [caxis](#) | [colormap](#) | [ColorSpec](#) | [fill3](#) | [patch](#)

# fill3

---

## Purpose

Filled 3-D polygons



## Syntax

```
fill3(X,Y,Z,C)
fill3(X,Y,Z,ColorSpec)
fill3(X1,Y1,Z1,C1,X2,Y2,Z2,C2,...)
fill3(...,'PropertyName',PropertyValue)
h = fill3(...)
```

## Description

The `fill3` function creates flat-shaded and Gouraud-shaded polygons.

`fill3(X,Y,Z,C)` fills three-dimensional polygons.  $X$ ,  $Y$ , and  $Z$  triplets specify the polygon vertices. If  $X$ ,  $Y$ , or  $Z$  is a matrix, `fill3` creates  $n$  polygons, where  $n$  is the number of columns in the matrix. `fill3` closes the polygons by connecting the last vertex to the first when necessary.

$C$  specifies color, where  $C$  is a vector or matrix of indices into the current colormap. If  $C$  is a row vector, `length(C)` must equal `size(X,2)` and `size(Y,2)`; if  $C$  is a column vector, `length(C)` must equal `size(X,1)` and `size(Y,1)`.

`fill3(X,Y,Z,ColorSpec)` fills three-dimensional polygons defined by  $X$ ,  $Y$ , and  $Z$  with color specified by `ColorSpec`.

`fill3(X1,Y1,Z1,C1,X2,Y2,Z2,C2,...)` specifies multiple filled three-dimensional areas.

`fill3(...,'PropertyName',PropertyValue)` allows you to set values for specific patch properties.

`h = fill3(...)` returns a vector of handles to patch graphics objects, one handle per patch.

## Algorithms

If  $X$ ,  $Y$ , and  $Z$  are matrices of the same size, `fill3` forms a vertex from the corresponding elements of  $X$ ,  $Y$ , and  $Z$  (all from the same matrix location), and creates one polygon from the data in each column.

If  $X$ ,  $Y$ , or  $Z$  is a matrix, `fill3` replicates any column vector argument to produce matrices of the required size.

If you specify color using `ColorSpec`, `fill3` generates flat-shaded polygons and sets the patch object `FaceColor` property to an RGB triple.

If you specify color using  $C$ , `fill3` scales the elements of  $C$  by the axes property `CLim`, which specifies the color axis scaling parameters, before indexing the current colormap.

If  $C$  is a row vector, `fill3` generates flat-shaded polygons and sets the `FaceColor` property of the patch objects to 'flat'. Each element becomes the `CData` property value for the respective patch object.

If  $C$  is a column vector or a matrix, `fill3` generates polygons with interpolated colors and sets the patch object `FaceColor` property to 'interp'. `fill3` uses a linear interpolation of the vertex colormap indices when generating polygons with interpolated colors. The elements in one column become the `CData` property value for the respective patch object. If  $C$  is a column vector, `fill3` replicates the column vector to produce the required sized matrix.

## Examples

Create four triangles with interpolated colors.

```
X = [0 1 1 2;1 1 2 2;0 0 1 1];
Y = [1 1 1 1;1 0 1 0;0 0 0 0];
Z = [1 1 1 1;1 0 1 0;0 0 0 0];
C = [0.5000 1.0000 1.0000 0.5000;
 1.0000 0.5000 0.5000 0.1667;
 0.3330 0.3330 0.5000 0.5000];
fill3(X,Y,Z,C)
```

# fill3

---

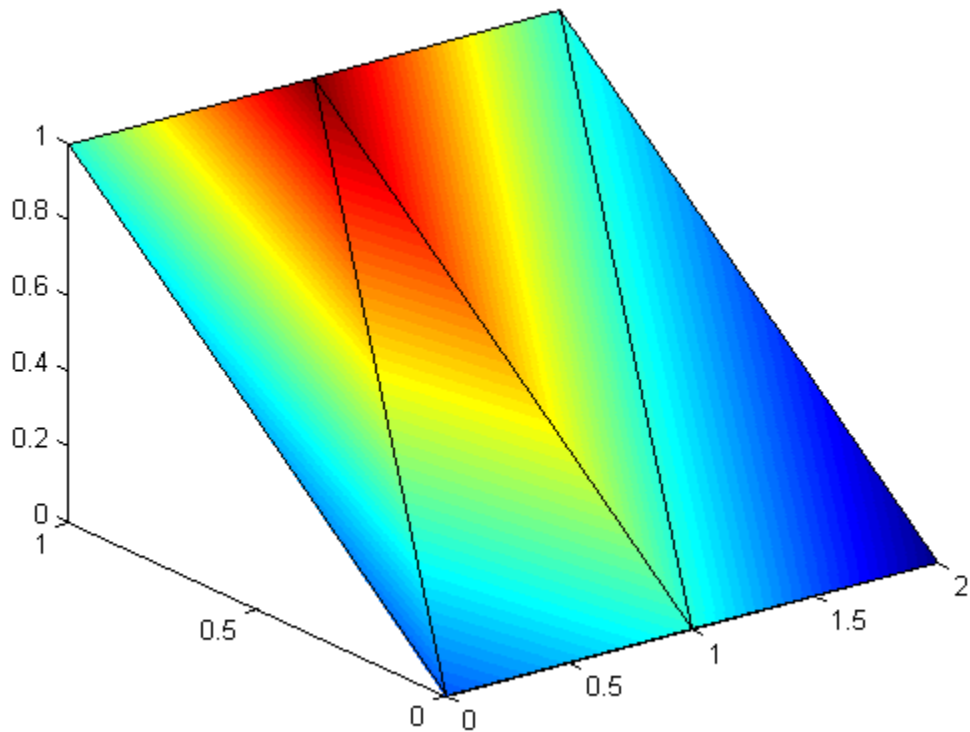

## See Also

[axis](#) | [caxis](#) | [colormap](#) | [ColorSpec](#) | [fill](#) | [patch](#)



**Purpose**

1-D digital filter

**Syntax**

```
y = filter(b,a,X)
[y,zf] = filter(b,a,X)
[y,zf] = filter(b,a,X,zi)
y = filter(b,a,X,zi,dim)
[...] = filter(b,a,X,[],dim)
```

**Description**

The `filter` function filters a data sequence using a digital filter which works for both real and complex inputs. The filter is a *direct form II transposed* implementation of the standard difference equation (see “Algorithm”).

`y = filter(b,a,X)` filters the data in vector `X` with the filter described by numerator coefficient vector `b` and denominator coefficient vector `a`. If `a(1)` is not equal to 1, `filter` normalizes the filter coefficients by `a(1)`. If `a(1)` equals 0, `filter` returns an error.

If `X` is a matrix, `filter` operates on the columns of `X`. If `X` is a multidimensional array, `filter` operates on the first nonsingleton dimension.

`[y,zf] = filter(b,a,X)` returns the final conditions, `zf`, of the filter delays. If `X` is a row or column vector, output `zf` is a column vector of `max(length(a),length(b))-1`. If `X` is a matrix, `zf` is an array of such vectors, one for each column of `X`, and similarly for multidimensional arrays.

`[y,zf] = filter(b,a,X,zi)` accepts initial conditions, `zi`, and returns the final conditions, `zf`, of the filter delays. Input `zi` is a vector of length `max(length(a),length(b))-1`, or an array with the leading dimension of size `max(length(a),length(b))-1` and with remaining dimensions matching those of `X`.

`y = filter(b,a,X,zi,dim)` and `[...] = filter(b,a,X,[],dim)` operate across the dimension `dim`.

# filter

---

## Examples

You can use `filter` to find a running average without using a `for` loop. This example finds the running average of a 16-element vector, using a window size of 5.

```
data = [1:0.2:4]';
windowSize = 5;
filter(ones(1,windowSize)/windowSize,1,data)
```

```
ans =
 0.2000
 0.4400
 0.7200
 1.0400
 1.4000
 1.6000
 1.8000
 2.0000
 2.2000
 2.4000
 2.6000
 2.8000
 3.0000
 3.2000
 3.4000
 3.6000
```

## Algorithms

The `filter` function is implemented as a direct form II transposed structure,

$$a(1)*y(n) = b(1)*x(n) + b(2)*x(n-1) + \dots + b(nb+1)*x(n-nb) \\ - a(2)*y(n-1) - \dots - a(na+1)*y(n-na)$$

where  $n-1$  is the filter order, which handles both FIR and IIR filters [1],  $na$  is the feedback filter order, and  $nb$  is the feedforward filter order. Due to normalization, assume  $a(1) = 1$ .

or



# filter2

---

**Purpose** 2-D digital filter

**Syntax**  
`Y = filter2(h,X)`  
`Y = filter2(h,X,shape)`

**Description** `Y = filter2(h,X)` filters the data in `X` with the two-dimensional FIR filter in the matrix `h`. It computes the result, `Y`, using two-dimensional correlation, and returns the central part of the correlation that is the same size as `X`.

`Y = filter2(h,X,shape)` returns the part of `Y` specified by the `shape` parameter. `shape` is a string with one of these values:

`'full'` Returns the full two-dimensional correlation. In this case, `Y` is larger than `X`.

`'same'` (default) Returns the central part of the correlation. In this case, `Y` is the same size as `X`.

`'valid'` Returns only those parts of the correlation that are computed without zero-padded edges. In this case, `Y` is smaller than `X`.

**Tips** Two-dimensional correlation is equivalent to two-dimensional convolution with the filter matrix rotated 180 degrees. See the Algorithm section for more information about how `filter2` performs linear filtering.

**Algorithms** Given a matrix `X` and a two-dimensional FIR filter `h`, `filter2` rotates your filter matrix 180 degrees to create a convolution kernel. It then calls `conv2`, the two-dimensional convolution function, to implement the filtering operation.

`filter2` uses `conv2` to compute the full two-dimensional convolution of the FIR filter with the input matrix. By default, `filter2` then extracts the central part of the convolution that is the same size as the input

matrix, and returns this as the result. If the `shape` parameter specifies an alternate part of the convolution for the result, `filter2` returns the appropriate part.

## See Also

`conv2` | `filter`

# find

---

**Purpose** Find indices and values of nonzero elements

**Syntax**

```
ind = find(X)
ind = find(X, k)
ind = find(X, k, 'first')
ind = find(X, k, 'last')
[row,col] = find(X, ...)
[row,col,v] = find(X, ...)
```

**Description** `ind = find(X)` locates all nonzero elements of array `X`, and returns the linear indices of those elements in vector `ind`. If `X` is a row vector, then `ind` is a row vector; otherwise, `ind` is a column vector. If `X` contains no nonzero elements or is an empty array, then `ind` is an empty array.

`ind = find(X, k)` or `ind = find(X, k, 'first')` returns at most the first `k` indices corresponding to the nonzero entries of `X`. `k` must be a positive integer, but it can be of any numeric data type.

`ind = find(X, k, 'last')` returns at most the last `k` indices corresponding to the nonzero entries of `X`.

`[row,col] = find(X, ...)` returns the row and column indices of the nonzero entries in the matrix `X`. This syntax is especially useful when working with sparse matrices. If `X` is an `N`-dimensional array with `N > 2`, `col` contains linear indices for the columns. For example, for a 5-by-7-by-3 array `X` with a nonzero element at `X(4,2,3)`, `find` returns 4 in `row` and 16 in `col`. That is, (7 columns in page 1) + (7 columns in page 2) + (2 columns in page 3) = 16.

`[row,col,v] = find(X, ...)` returns a column or row vector `v` of the nonzero entries in `X`, as well as row and column indices. If `X` is a logical expression, then `v` is a logical array. Output `v` contains the non-zero elements of the logical array obtained by evaluating the expression `X`. For example,

```
A= magic(4)
A =
 16 2 3 13
 5 11 10 8
```

```

 9 7 6 12
 4 14 15 1

```

```
[r,c,v]= find(A>10);
```

```
r', c', v'
```

```
ans =
```

```
 1 2 4 4 1 3
```

```
ans =
```

```
 1 2 2 3 4 4
```

```
ans =
```

```
 1 1 1 1 1 1
```

Here the returned vector  $v$  is a logical array that contains the nonzero elements of  $N$  where

```
N=(A>10)
```

## Examples

### Example 1

```
X = [1 0 4 -3 0 0 0 8 6];
```

```
indices = find(X)
```

returns linear indices for the nonzero entries of  $X$ .

```
indices =
```

```
 1 3 4 8 9
```

### Example 2

You can use a logical expression to define  $X$ . For example,

```
find(X > 2)
```

returns linear indices corresponding to the entries of  $X$  that are greater than 2.

```
ans =
```

```
 3 8 9
```

### Example 3

The following `find` command

```
X = [3 2 0; -5 0 7; 0 0 1];
[r,c,v] = find(X)
```

returns a vector of row indices of the nonzero entries of X

```
r =
 1
 2
 1
 2
 3
```

a vector of column indices of the nonzero entries of X

```
c =
 1
 1
 2
 3
 3
```

and a vector containing the nonzero entries of X.

```
v =
 3
 -5
 2
 7
 1
```

### Example 4

The expression

```
X = [3 2 0; -5 0 7; 0 0 1];
[r,c,v] = find(X>2)
```



returns a vector of row indices of the nonzero entries of N where  $N=(X>2)$

```
r =
 1
 2
```

a vector of column indices of the nonzero entries of N where  $N=(X>2)$

```
c =
 1
 3
```

and a logical array that contains the nonzero elements of N where  $N=(X>2)$ .

```
v =
 1
 1
```

Recall that when you use `find` on a logical expression, the output vector `v` does not contain the nonzero entries of the input array. Instead, it contains the nonzero values returned after evaluating the logical expression.

### **Example 5**

Some operations on a vector

```
x = [11 0 33 0 55]';
```

```
find(x)
ans =
 1
 3
 5
```

```
find(x == 0)
ans =
 2
```

# find

---

```
4
find(0 < x & x < 10*pi)
ans =
 1
```

## Example 6

For the matrix

```
M = magic(3)
M =
 8 1 6
 3 5 7
 4 9 2
```

```
find(M > 3, 4)
```

returns the indices of the first four entries of M that are greater than 3.

```
ans =
 1
 3
 5
 6
```

## Example 7

If X is a vector of all zeros, `find(X)` returns an empty matrix. For example,

```
indices = find([0;0;0])
indices =
 Empty matrix: 0-by-1
```

## See Also

[nonzeros](#) | [sparse](#) | [colon](#) | [ind2sub](#)

## Concepts

- “Find Array Elements That Meet a Condition”

---

|                    |                                                                                                                                                                                                                                                                                                                                                                                                                                                                     |
|--------------------|---------------------------------------------------------------------------------------------------------------------------------------------------------------------------------------------------------------------------------------------------------------------------------------------------------------------------------------------------------------------------------------------------------------------------------------------------------------------|
| <b>Purpose</b>     | Find all graphics objects                                                                                                                                                                                                                                                                                                                                                                                                                                           |
| <b>Syntax</b>      | <pre>object_handles = findall(handle_list) object_handles = findall(handle_list, 'property', 'value', ...)</pre>                                                                                                                                                                                                                                                                                                                                                    |
| <b>Description</b> | <p><code>object_handles = findall(handle_list)</code> returns the handles, including hidden handles, of all objects in the hierarchy under the objects identified in <code>handle_list</code>.</p> <p><code>object_handles = findall(handle_list, 'property', 'value', ...)</code> returns the handles of all objects in the hierarchy under the objects identified in <code>handle_list</code> that have the specified properties set to the specified values.</p> |
| <b>Tips</b>        | <code>findall</code> is similar to <code>findobj</code> , except that it finds objects even if their <code>HandleVisibility</code> is set to <code>off</code> .                                                                                                                                                                                                                                                                                                     |
| <b>Examples</b>    | <pre>plot(1:10) xlabel xlab a = findall(gcf) b = findobj(gcf) c = findall(b, 'Type', 'text') % returns the xlabel handle twice d = findobj(b, 'Type', 'text') % can't find the xlabel handle</pre>                                                                                                                                                                                                                                                                  |
| <b>See Also</b>    | <code>allchild</code>   <code>findobj</code>                                                                                                                                                                                                                                                                                                                                                                                                                        |

# findfigs

---

**Purpose** Find visible offscreen figures

**Syntax** `findfigs`

**Description** `findfigs` finds all visible figure windows whose display area is off the screen and positions them on the screen.

A window appears to the MATLAB software to be offscreen when its display area (the area not covered by the window's title bar, menu bar, and toolbar) does not appear on the screen.

This function is useful when you are bringing an application from a larger monitor to a smaller one (or one with lower resolution). Windows visible on the larger monitor may appear offscreen on a smaller monitor. Using `findfigs` ensures that all windows appear on the screen.

**Purpose**

Locate graphics objects with specific properties

**Syntax**

```
findobj
h = findobj
h = findobj('PropertyName',PropertyValue,...)
h =
findobj('PropertyName',PropertyValue,'-logicaloperator',
 'PropertyName',PropertyValue,...)
h = findobj('-regexp','PropertyName','regexp',...)
h = findobj('-property','PropertyName')
h = findobj(objhandles,...)
h = findobj(objhandles,'-depth',d,...)
h =
findobj(objhandles,'flat','PropertyName',PropertyValue,...)
```

**Description**

findobj returns handles of the root object and all its descendants without assigning the result to a variable.

h = findobj returns handles of the root object and all its descendants.

h = findobj('PropertyName',PropertyValue,...) returns handles of all graphics objects having the property *PropertyName*, set to the value *PropertyValue*. You can specify more than one property/value pair, in which case, findobj returns only those objects having all specified values.

h =  
findobj('PropertyName',PropertyValue,'-logicaloperator',  
*PropertyName*,PropertyValue,...) applies the logical operator to the property value matching. Possible values for *-logicaloperator* are:

- -and
- -or
- -xor
- -not

For more information on logical operators, see “Logical Operations”.

`h = findobj('-regex','PropertyName','regex',...)` matches objects using regular expressions as if the value of you passed the property `PropertyName` to the `regex` function as

```
regex(PropertyValue,'regex')
```

If a match occurs, `findobj` returns the object handle. See the `regex` function for information on how the MATLAB software uses regular expressions.

`h = findobj('-property','PropertyName')` finds all objects having the specified property.

`h = findobj(objhandles,...)` restricts the search to objects listed in `objhandles` and their descendants.

`h = findobj(objhandles,'-depth',d,...)` specifies the depth of the search. The depth argument `d` controls how many levels under the handles in `objhandles` MATLAB traverses. Specify `d` as `inf` to get the default behavior of all levels. Specify `d` as `0` to get the same behavior as using the `flat` argument.

`h = findobj(objhandles,'flat','PropertyName',PropertyValue,...)` restricts the search to those objects listed in `objhandles` and does not search descendants.

`findobj` returns an error if a handle refers to a nonexistent graphics object.

`findobj` correctly matches any legal property value. For example,

```
findobj('Color','r')
```

finds all objects having a `Color` property set to `red`, `r`, or `[1 0 0]`.

When a graphics object is a descendant of more than one object identified in `objhandles`, MATLAB searches the object each time `findobj` encounters its handle. Therefore, implicit references to a graphics object can result in multiple returns of its handle.

To find handle objects that meet specified conditions, use `handle.findobj`.

## Examples

Find all line objects in the current axes:

```
h = findobj(gca,'Type','line')
```

---

Find all objects having a `Label` set to 'foo' and a `String` set to 'bar':

```
h = findobj('Label','foo','-and','String','bar');
```

---

Find all objects whose `String` is not 'foo' and is not 'bar':

```
h = findobj('-not','String','foo','-not','String','bar');
```

---

Find all objects having a `String` set to 'foo' and a `Tag` set to 'button one' and whose `Color` is not 'red' or 'blue':

```
h = findobj('String','foo','-and','Tag','button one',...
 '-and','-not',{'Color','red','-or','Color','blue'})
```

---

Find all objects for which you have assigned a value to the `Tag` property (that is, the value is not the empty string ''):

```
h = findobj('-regexp','Tag','[^'']')
```

---

Find all children of the current figure that have their `BackgroundColor` property set to a certain shade of gray ([.7 .7 .7]). This statement also searches the current figure for the matching property value pair.

```
h = findobj(gcf,'-depth',1,'BackgroundColor',[.7 .7 .7])
```

# findobj

---

## See Also

`copyobj` | `findall` | `handle.findobj` | `gcf` | `gca` | `gcbo` | `gco` | `get`  
| `regexp` | `set`

## Tutorials

- “Example — Using Logical Operators and Regular Expression”



## Purpose

Find handle objects matching specified conditions

## Syntax

```
Hmatch = findobj(Hobj,<conditions>)
Hmatch = findobj(Hobj,'-property','PropertyName')
```

## Description

`Hmatch = findobj(Hobj,<conditions>)` finds handle class objects that meet the specified conditions. Specify conditions as property name/property value pairs, indicating that the objects you are trying to find have specific property values.

The `Hobj` argument must be an array of handle objects. The returned value, `Hmatch` contains an array of object handles that match the conditions.

`Hmatch = findobj(Hobj,'-property','PropertyName')` finds all object in `Hobj` having the specified property.

`findobj` has access only to public members of the objects in `Hobj`. `findobj` can find dynamic properties. See “Find Handle Objects” for more information on using `findobj`.

You cannot use regular expression with handle class objects.

## Examples

Find the object with a specific property value. Given the handle class, `BasicHandle`:

```
classdef BasicHandle < handle
 properties
 Prop1
 end
 methods
 function obj = BasicHandle(val)
 if nargin > 0
 obj.Prop1 = val;
 end
 end
 end
end
end
```

## findobj (handle)

---

Create an array of BasicHandle objects:

```
h(1) = BasicHandle(7);
h(2) = BasicHandle(11);
h(3) = BasicHandle(27);
```

Find the handle of the object whose Prop1 property has a value of 7:

```
h7 = findobj(h, 'Prop1', 7);
h7.Prop1
```

```
ans =
```

```
7
```

Find the object with a specific dynamic property. Given the button class:

```
classdef button < dynamicprops
 properties
 UiHandle
 end
 methods
 function obj = button(pos)
 if nargin > 0
 if length(pos) == 4
 obj.UiHandle = uicontrol('Position', pos, ...
 'Style', 'pushbutton');
 else
 error('Improper position')
 end
 end
 end
 end
end
end
```

Create an array of button objects, only one element of which defines a dynamic property. Use `findobj` to get the handle of the object with the dynamic property named `ButtonCoord`:

```
b(1) = button([20 40 80 20]);
b(1).addprop('ButtonCoord');
b(1).ButtonCoord = [2,3];
b(2) = button([120 40 80 20]);
b(3) = button([220 40 80 20]);

h = findobj(b, '-property', 'ButtonCoord');
h.ButtonCoord

ans =

 2 3
```

## See Also

[findprop](#) | [handle](#)

# findprop (handle)

---

**Purpose** Find meta.property object associated with property name

**Syntax** `p = findprop(h, 'Name')`

**Description** `p = findprop(h, 'Name')` returns the meta.property object associated with the property Name of the object h. Name can be a property defined by the class of h or a dynamic property defined only for the object h.

**Examples** Use findprop to view property attribute settings:

```
findprop(containers.Map, 'Count')
```

```
ans =
```

```
property with properties:
```

```
 Name: 'Count'
 Description: 'Number of pairs in the collection'
DetailedDescription: ''
 GetAccess: 'public'
 SetAccess: 'private'
 Dependent: 1
 Constant: 0
 Abstract: 0
 Transient: 1
 Hidden: 0
 GetObservable: 0
 SetObservable: 0
 AbortSet: 0
 GetMethod: []
 SetMethod: []
 DefiningClass: [1x1 meta.class]
```

**See Also** `handle` | `findobj (handle)` | `meta.property`

**How To** • “Getting Information About Properties”

- “Getting Information About Properties”
- “Dynamic Properties — Adding Properties to an Instance”

# findstr

---

**Purpose** Find string within another, longer string

---

**Note** `findstr` is not recommended. Use `strfind` instead.

---

**Syntax** `k = findstr(str1, str2)`

**Description** `k = findstr(str1, str2)` searches the longer of the two input strings for any occurrences of the shorter string, returning the starting index of each such occurrence in the double array `k`. If no occurrences are found, then `findstr` returns the empty array, `[]`.

The search performed by `findstr` is case sensitive. Any leading and trailing blanks in either input string are explicitly included in the comparison.

Unlike the `strfind` function, the order of the input arguments to `findstr` is not important. This can be useful if you are not certain which of the two input strings is the longer one.

**Examples** `s = 'Find the starting indices of the shorter string.';`

```
findstr(s, 'the')
ans =
 6 30
```

```
findstr('the', s)
ans =
 6 30
```

**See Also** `strfind` | `strtok` | `strcmp` | `strncmp` | `strcmpi` | `strncmpi` | `regex` | `regexp` | `regpi` | `regprep`

---

|                    |                                                                                                                                                                                                                                                                                                                                                                                                                                                                                                                                                                                                                                                                                                                                                                                                                 |
|--------------------|-----------------------------------------------------------------------------------------------------------------------------------------------------------------------------------------------------------------------------------------------------------------------------------------------------------------------------------------------------------------------------------------------------------------------------------------------------------------------------------------------------------------------------------------------------------------------------------------------------------------------------------------------------------------------------------------------------------------------------------------------------------------------------------------------------------------|
| <b>Purpose</b>     | Termination file for MATLAB program                                                                                                                                                                                                                                                                                                                                                                                                                                                                                                                                                                                                                                                                                                                                                                             |
| <b>Description</b> | <p>When the MATLAB program quits, it runs a script called <code>finish.m</code>, if the script exists and is on the search path MATLAB uses or in the current directory. This is a file you create yourself that instructs MATLAB to perform any final tasks just prior to terminating. For example, you might want to save the data in your workspace to a MAT-file before MATLAB exits.</p> <p><code>finish.m</code> is invoked whenever you do one of the following:</p> <ul style="list-style-type: none"><li>• Click the Close box  in the MATLAB desktop on Microsoft Windows platforms or the equivalent on UNIX platforms</li><li>• Type <code>quit</code> or <code>exit</code> at the Command Window prompt</li></ul> |
| <b>Tips</b>        | <p>When using Handle Graphics features in <code>finish.m</code>, use <code>uiwait</code>, <code>waitfor</code>, or <code>drawnow</code> so that figures are visible. See the reference pages for these functions for more information.</p>                                                                                                                                                                                                                                                                                                                                                                                                                                                                                                                                                                      |
| <b>Examples</b>    | <p>Two sample termination files are provided with MATLAB in <code>matlabroot/toolbox/local</code>.</p> <ul style="list-style-type: none"><li>• <code>finishesav.m</code> — Saves the workspace to a MAT-file when MATLAB quits.</li><li>• <code>finishdlg.m</code> — Displays a dialog allowing you to cancel quitting and saves the workspace. See also the “Confirmation Dialogs Preferences” and the option for exiting MATLAB.</li></ul> <p>To create a termination file, make a copy of one of these sample files, changing the name to <code>finish.m</code>, and add it to the path to use it. You can modify the file to include any operations you want the termination file to perform.</p>                                                                                                           |
| <b>See Also</b>    | <code>quit</code>   <code>exit</code>   <code>startup</code>                                                                                                                                                                                                                                                                                                                                                                                                                                                                                                                                                                                                                                                                                                                                                    |
| <b>How To</b>      | <ul style="list-style-type: none"><li>• “Exit MATLAB”</li></ul>                                                                                                                                                                                                                                                                                                                                                                                                                                                                                                                                                                                                                                                                                                                                                 |

# fitsdisp

---

**Purpose** Display FITS metadata

**Syntax** `fitsdisp(filename)`  
`fitsdisp(filename,Name,Value)`

**Description** `fitsdisp(filename)` displays metadata for all the Header/Data Units (HDUs) found in the FITS file specified by `filename`.

`fitsdisp(filename,Name,Value)` displays metadata for all the Header/Data Units (HDUs) found in the FITS file with additional options specified by one or more `Name,Value` pair arguments.

**Input Arguments**

**filename**

Text string specifying the name of an existing FITS file.

**Name-Value Pair Arguments**

Specify optional comma-separated pairs of `Name,Value` arguments. `Name` is the argument name and `Value` is the corresponding value. `Name` must appear inside single quotes ( ' '). You can specify several name and value pair arguments in any order as `Name1,Value1,...,NameN,ValueN`.

**'Index'**

Positive scalar value or vector specifying the HDUs.

**'Mode'**

One of the following strings:

- `standard` – Display standard keywords
- `min` – Display only HDU types and sizes
- `full` – Display all HDU keywords

**Default:** `standard`



**Examples**

Display metadata in the 2nd HDU in the FITS file.

```
fitsdisp('tst0012.fits', 'Index', 2);
```

Display the metadata in the 1st, 3rd, and 5th HDUs in a file.

```
fitsdisp('tst0012.fits', 'Index', [1 3 5]);
```

Display all metadata in the 5th HDU in a file

```
fitsdisp('tst0012.fits', 'Index', 5, 'Mode', 'full');
```

**References**

For copyright information, see the `cfitsiocopyright.txt` file.

**See Also**

`fitsread` | `fitswrite` | `fitsinfo`

# fitsinfo

---

**Purpose** Information about FITS file

**Syntax** `info = fitsinfo(filename)`

**Description** `info = fitsinfo(filename)` returns the structure, `info`, with fields that contain information about the contents of a Flexible Image Transport System (FITS) file. `filename` is a string enclosed in single quotes that specifies the name of the FITS file.

The `info` structure contains the following fields, listed in the order they appear in the structure. In addition, the `info` structure can also contain information about any number of optional file components, called *extensions* in FITS terminology. For more information, see “FITS File Extensions” on page 1-2186.

| Field Name  | Description                                                 | Return Type           |
|-------------|-------------------------------------------------------------|-----------------------|
| Filename    | Name of the file                                            | String                |
| FileModDate | File modification date                                      | String                |
| FileSize    | Size of the file in bytes                                   | double                |
| Contents    | List of extensions in the file in the order that they occur | Cell array of strings |
| PrimaryData | Information about the primary data in the FITS file         | Structure array       |

## PrimaryData

The `PrimaryData` field is a structure that describes the primary data in the file. The following table lists the fields in the order they appear in the structure.

| Field Name       | Description                                                                                                                                                                                                                          | Return Type  |
|------------------|--------------------------------------------------------------------------------------------------------------------------------------------------------------------------------------------------------------------------------------|--------------|
| DataType         | Precision of the data                                                                                                                                                                                                                | String       |
| Size             | Size of each dimension. The number of rows correspond to the value of the NAXIS2 keyword, while the number of columns correspond to the value of the NAXIS1 keyword. Any further dimensions correspond to NAXIS3, NAXIS4, and so on. | double array |
| DataSize         | Size of the primary data in bytes                                                                                                                                                                                                    | double       |
| MissingDataValue | Value used to represent undefined data                                                                                                                                                                                               | double       |
| Intercept        | Value, used with Slope, to calculate actual pixel values from the array pixel values, using the equation: $\text{actual\_value} = \text{Slope} * \text{array\_value} + \text{Intercept}$                                             | double       |
| Slope            | Value, used with Intercept, to calculate actual pixel values from the array pixel values, using the equation: $\text{actual\_value} = \text{Slope} * \text{array\_value} + \text{Intercept}$                                         | double       |

| Field Name | Description                                                                                                 | Return Type           |
|------------|-------------------------------------------------------------------------------------------------------------|-----------------------|
| Offset     | Number of bytes from beginning of the file to the location of the first data value                          | double                |
| Keywords   | A number-of-keywords-by-3 cell array containing keywords, values, and comments of the header in each column | Cell array of strings |

## FITS File Extensions

A FITS file can also include optional extensions. If the file contains any of these extensions, the `info` structure can contain these additional fields.

- `AsciiTable` — Numeric information in tabular format, stored as ASCII characters
- `BinaryTable` — Numeric information in tabular format, stored in binary representation
- `Image` — A multidimensional array of pixels
- `Unknown` — Nonstandard extension

### AsciiTable Extension

The `AsciiTable` structure contains the following fields, listed in the order they appear in the structure.

| Field Name | Description                      | Return Type  |
|------------|----------------------------------|--------------|
| Rows       | Number of rows in the table      | double       |
| RowSize    | Number of characters in each row | double       |
| NFields    | Number of fields in each row     | double array |

| Field Name       | Description                                                                                                                                                                             | Return Type           |
|------------------|-----------------------------------------------------------------------------------------------------------------------------------------------------------------------------------------|-----------------------|
| FieldFormat      | A 1-by-NFields cell containing formats in which each field is encoded. The formats are FORTRAN-77 format codes.                                                                         | Cell array of strings |
| FieldPrecision   | A 1-by-NFields cell containing precision of the data in each field                                                                                                                      | Cell array of strings |
| FieldWidth       | A 1-by-NFields array containing the number of characters in each field                                                                                                                  | double array          |
| FieldPos         | A 1-by-NFields array of numbers representing the starting column for each field                                                                                                         | double array          |
| DataSize         | Size of the data in the table in bytes                                                                                                                                                  | double                |
| MissingDataValue | A 1-by-NFields array of numbers used to represent undefined data in each field                                                                                                          | Cell array of strings |
| Intercept        | A 1-by-NFields array of numbers used along with Slope to calculate actual data values from the array data values using the equation: $actual\_value = Slope * array\_value + Intercept$ | double array          |
| Slope            | A 1-by-NFields array of numbers used with Intercept to calculate true data values from the array data values using the equation: $actual\_value = Slope * array\_value + Intercept$     | double array          |

| Field Name | Description                                                                                                     | Return Type           |
|------------|-----------------------------------------------------------------------------------------------------------------|-----------------------|
| Offset     | Number of bytes from beginning of the file to the location of the first data value in the table                 | double                |
| Keywords   | A number-of-keywords-by-3 cell array containing all the Keywords, Values and Comments in the ASCII table header | Cell array of strings |

## BinaryTable Extension

The BinaryTable structure contains the following fields, listed in the order they appear in the structure.

| Field Name     | Description                                                                                                                                    | Return Type           |
|----------------|------------------------------------------------------------------------------------------------------------------------------------------------|-----------------------|
| Rows           | Number of rows in the table                                                                                                                    | double                |
| RowSize        | Number of bytes in each row                                                                                                                    | double                |
| NFields        | Number of fields in each row                                                                                                                   | double                |
| FieldFormat    | A 1-by-NFields cell array containing the data type of the data in each field. The data type is represented by a FITS binary table format code. | Cell array of strings |
| FieldPrecision | A 1-by-NFields cell containing precision of the data in each field                                                                             | Cell array of strings |
| FieldSize      | A 1-by-NFields array, where each element contains the number of values in the Nth field                                                        | double array          |

| Field Name       | Description                                                                                                                                                                                                         | Return Type           |
|------------------|---------------------------------------------------------------------------------------------------------------------------------------------------------------------------------------------------------------------|-----------------------|
| DataSize         | Size of the data in the Binary Table, in bytes. Includes any data past the main table.                                                                                                                              | double                |
| MissingDataValue | An 1-by-NFields array of numbers used to represent undefined data in each field                                                                                                                                     | Cell array of double  |
| Intercept        | A 1-by-NFields array of numbers used along with Slope to calculate actual data values from the array data values using the equation: $\text{actual\_value} = \text{slope} * \text{array\_value} + \text{Intercept}$ | double array          |
| Slope            | A 1-by-NFields array of numbers used with Intercept to calculate true data values from the array data values using the equation: $\text{actual\_value} = \text{Slope} * \text{array\_value} + \text{Intercept}$     | double array          |
| Offset           | Number of bytes from beginning of the file to the location of the first data value                                                                                                                                  | double                |
| ExtensionSize    | Size of any data past the main table, in bytes                                                                                                                                                                      | double                |
| ExtensionOffset  | Number of bytes from the beginning of the file to any data past the main table                                                                                                                                      | double                |
| Keywords         | A number-of-keywords-by-3 cell array containing all the Keywords, values, and comments in the Binary Table header                                                                                                   | Cell array of strings |

## Image Extension

The Image structure contains the following fields, listed in the order they appear in the structure.

| Field Name       | Description                                                                                                                                                                                                                          | Return Type  |
|------------------|--------------------------------------------------------------------------------------------------------------------------------------------------------------------------------------------------------------------------------------|--------------|
| DataType         | Precision of the data                                                                                                                                                                                                                | String       |
| Size             | Size of each dimension. The number of rows correspond to the value of the NAXIS2 keyword, while the number of columns correspond to the value of the NAXIS1 keyword. Any further dimensions correspond to NAXIS3, NAXIS4, and so on. | double array |
| DataSize         | Size of the data in the Image extension in bytes                                                                                                                                                                                     | double       |
| Offset           | Number of bytes from the beginning of the file to the first data value                                                                                                                                                               | double       |
| MissingDataValue | Value used to represent undefined data                                                                                                                                                                                               | double       |
| Intercept        | Value, used with Slope, to calculate actual pixel values from the array pixel values, using the equation: $actual\_value = Slope * array\_value + Intercept$                                                                         | double       |



| Field Name | Description                                                                                                                                                                                  | Return Type           |
|------------|----------------------------------------------------------------------------------------------------------------------------------------------------------------------------------------------|-----------------------|
| Slope      | Value, used with Intercept, to calculate actual pixel values from the array pixel values, using the equation: $\text{actual\_value} = \text{Slope} * \text{array\_value} + \text{Intercept}$ | double                |
| Keywords   | A number-of-keywords-by-3 cell array containing all the Keywords, values, and comments in the Binary Table header                                                                            | Cell array of strings |

### Unknown Structure

The Unknown structure contains the following fields, listed in the order they appear in the structure.

| Field Name       | Description                                                        | Return Type  |
|------------------|--------------------------------------------------------------------|--------------|
| DataType         | Precision of the data                                              | String       |
| Size             | Sizes of each dimension                                            | double array |
| DataSize         | Size of the data in nonstandard extensions, in bytes               | double       |
| Offset           | Number of bytes from beginning of the file to the first data value | double       |
| MissingDataValue | Representation of undefined data                                   | double       |

| Field Name | Description                                                                                                                                                                                | Return Type           |
|------------|--------------------------------------------------------------------------------------------------------------------------------------------------------------------------------------------|-----------------------|
| Intercept  | Value, used with Slope, to calculate actual data values from the array data values, using the equation: $\text{actual\_value} = \text{Slope} * \text{array\_value} + \text{Intercept}$     | double                |
| Slope      | Value, used with Intercept, to calculate actual data values from the array data values, using the equation: $\text{actual\_value} = \text{Slope} * \text{array\_value} + \text{Intercept}$ | double                |
| Keywords   | A number-of-keywords-by-3 cell array containing all the Keywords, values, and comments in the Binary Table header                                                                          | Cell array of strings |

## Examples

### Get Information About FITS File

Use `fitsinfo` to obtain information about the FITS file `tst0012.fits`. In addition to its primary data, the file also contains an example of the extensions `BinaryTable`, `Unknown`, `Image`, and `AsciiTable`.

```
S = fitsinfo('tst0012.fits')
```

```
S =
 Filename: 'matlabroot\toolbox\matlab\demos\tst0012.fits'
 FileModDate: '12-Mar-2001 18:37:46'
 FileSize: 109440
 Contents: {'Primary' 'Binary Table' 'Unknown'
'Image' 'ASCII Table'}
 PrimaryData: [1x1 struct]
 BinaryTable: [1x1 struct]
```

```

Unknown: [1x1 struct]
Image: [1x1 struct]
AsciiTable: [1x1 struct]

```

View the PrimaryData field.

S.PrimaryData

ans =

```

DataType: 'single'
Size: [109 102]
DataSize: 44472
MissingDataValue: []
Intercept: 0
Slope: 1
Offset: 2880
Keywords: {25x3 cell}

```

The PrimaryData field describes the data in the file. For example, the Size field indicates the data is a 109-by-102 matrix.

View the AsciiTable field.

S.AsciiTable

ans =

```

Rows: 53
RowSize: 59
NFields: 8
FieldFormat: {'A9' 'F6.2' 'I3' 'E10.4' 'D20.15' 'A5' 'A1' 'I4'}
FieldPrecision: {1x8 cell}
FieldWidth: [9 6.2000 3 10.4000 20.1500 5 1 4]
FieldPos: [1 11 18 22 33 54 54 55]
DataSize: 3127
MissingDataValue: {'*' '---.--' ' ' '*' [] '*' '*' '*' ''}
Intercept: [0 0 -70.2000 0 0 0 0 0]
Slope: [1 1 2.1000 1 1 1 1 1]

```

# fitsinfo

---

Offset: 103680  
Keywords: {65x3 cell}

The `AsciiTable` field describes the `AsciiTable` extension. For example, using the `FieldWidth` and `FieldPos` fields you can determine the length and location of each field within a row.

## See Also

`fitsread` | `fitswrite` | `fitsdisp`

---

|                        |                                                                                                                                                                                                                                                                                                                                                                                                                                                                                                                                                                                                                                                                                                                                                                                                                                                                                                                |
|------------------------|----------------------------------------------------------------------------------------------------------------------------------------------------------------------------------------------------------------------------------------------------------------------------------------------------------------------------------------------------------------------------------------------------------------------------------------------------------------------------------------------------------------------------------------------------------------------------------------------------------------------------------------------------------------------------------------------------------------------------------------------------------------------------------------------------------------------------------------------------------------------------------------------------------------|
| <b>Purpose</b>         | Read data from FITS file                                                                                                                                                                                                                                                                                                                                                                                                                                                                                                                                                                                                                                                                                                                                                                                                                                                                                       |
| <b>Syntax</b>          | <pre>data = fitsread(filename) data = fitsread(filename,extname) data = fitsread(filename,extname,index) data = fitsread(filename,Name,Value)</pre>                                                                                                                                                                                                                                                                                                                                                                                                                                                                                                                                                                                                                                                                                                                                                            |
| <b>Description</b>     | <p><code>data = fitsread(filename)</code> reads the primary data of the Flexible Image Transport System (FITS) file specified by the text string <code>filename</code>. The function replaces undefined data values with NaN and scales numeric data by the slope and intercept values, always returning double precision values.</p> <p><code>data = fitsread(filename,extname)</code> reads data from the FITS file extension specified by <code>extname</code>.</p> <p><code>data = fitsread(filename,extname,index)</code> reads data from the FITS file extension specified by <code>extname</code>. If there is more than one of the specified extensions in the file, <code>index</code> specifies the one to read.</p> <p><code>data = fitsread(filename,Name,Value)</code> reads data from the FITS file with additional options specified by one or more <code>Name,Value</code> pair arguments.</p> |
| <b>Input Arguments</b> | <p><b>filename</b><br/>Text string specifying the name of a FITS file.</p> <p><b>extname</b><br/>One of the following text strings specifying the name of a data array or extension in the FITS file. To determine the contents of a FITS, view the Contents field of the structure returned by <code>fitsinfo</code>.</p>                                                                                                                                                                                                                                                                                                                                                                                                                                                                                                                                                                                     |

## Data Arrays or Extensions

| Extname       | Description                                                                                           |
|---------------|-------------------------------------------------------------------------------------------------------|
| 'primary'     | Read data from the primary data array.                                                                |
| 'asciitable'  | Read data from the ASCII Table extension. The return value, <code>data</code> , is a 1-D cell array.  |
| 'binarytable' | Read data from the Binary Table extension. The return value, <code>data</code> , is a 1-D cell array. |
| 'image'       | Read data from the Image extension.                                                                   |
| 'unknown'     | Read data from the Unknown extension.                                                                 |

### index

Numeric value specifying which extension to read, if more than one exists in the file.

### Name-Value Pair Arguments

Specify optional comma-separated pairs of `Name`, `Value` arguments. `Name` is the argument name and `Value` is the corresponding value. `Name` must appear inside single quotes ( ' '). You can specify several name and value pair arguments in any order as `Name1, Value1, ..., NameN, ValueN`.

### 'info'

`info` structure returned by `fitsinfo` specifying the location of data to read.

---

**Note** Using the `info` structure returned by `fitsinfo` to specify the location of data in a FITS file can significantly improve performance, especially when reading multiple images from the file.

---

### 'PixelRegion'

Cell array {rows, cols, ...} specifying the boundaries of a subimage region to read from the file. Each dimension (rows, cols) is a vector of 1-based indices given either as START, [START STOP], or [START INCREMENT STOP]. This parameter is valid only for primary or image extensions.

#### **'raw'**

Specifies that fitsread should not scale the data read from the file or replace undefined values with NaN. Data read from the file is the same class as it is stored in the file.

#### **'TableColumns'**

Vector of 1-based indices specifying the columns to read from the ASCII or Binary table extension. This vector should contain unique and valid indices into the table data specified in increasing order. This parameter is valid only for ASCII or Binary extensions.

#### **'TableRows'**

Vector of 1-based indices specifying the rows to read from the ASCII or Binary table extension. This vector should contain unique and valid indices into the table data specified in increasing order. This parameter is valid only for ASCII or Binary extensions.

## **Output Arguments**

### **data**

Data returned from the FITS file.

## **Definitions**

### **extension**

A FITS file contains primary data and can optionally contain any number of optional components, called *extensions* in FITS terminology.

## **Examples**

Read primary data from FITS file

```
data = fitsread('tst0012.fits');
```

| Name | Size    | Bytes | Class  | Attributes |
|------|---------|-------|--------|------------|
| data | 109x102 | 88944 | double |            |

---

Inspect available extensions, read 'image' extension using the `extname` option.

```
info = fitsinfo('tst0012.fits');
% List of contents, includes any extensions if present.
disp(info.Contents);
imageData = fitsread('tst0012.fits','image');
```

---

Subsample the fifth plane of 'image' extension by 2.

```
info = fitsinfo('tst0012.fits');
rowend = info.Image.Size(1);
colend = info.Image.Size(2);
primaryData = fitsread('tst0012.fits','image',...
 'Info', info,...
 'PixelRegion',{[1 2 rowend], [1 2 colend], 5 });
```

---

Read every other row from an ASCII table.

```
info = fitsinfo('tst0012.fits');
rowend = info.AsciiTable.Rows;
tableData = fitsread('tst0012.fits','asciitable',...
 'Info', info,...
 'TableRows',[1:2:rowend]);
```

---

Read all data for the first, second and fifth columns of the Binary table.

```
info = fitsinfo('tst0012.fits');
```



```
rowend = info.BinaryTable.Rows;
tableData = fitsread('tst0012.fits', 'binarytable', ...
 'Info', info, ...
 'TableColumns', [1 2 5]);
```

## See Also

[fitswrite](#) | [fitsinfo](#) | [fitsdisp](#)

## Tutorials

- “Importing Flexible Image Transport System (FITS) Files”

# fitswrite

---

**Purpose** Write image to FITS file

**Syntax** `fitswrite(imagedata,filename)`  
`fitswrite(imagedata,filename,Name,Value)`

**Description** `fitswrite(imagedata,filename)` writes `imagedata` to the FITS file specified by `filename`. If `filename` does not exist, `fitswrite` creates the file as a simple FITS file. If `filename` exists, `fitswrite` overwrites the file or appends the image to the end of the file, depending on the value of the `writemode` argument.

`fitswrite(imagedata,filename,Name,Value)` writes `imagedata` to the FITS file specified by `filename` with additional options specified by one or more `Name,Value` pair arguments.

## Input Arguments

### **imagedata**

Image array.

### **filename**

Text string specifying the name of an existing FITS file or the name you want to assign to a new FITS file.

### **Name-Value Pair Arguments**

Specify optional comma-separated pairs of `Name,Value` arguments. `Name` is the argument name and `Value` is the corresponding value. `Name` must appear inside single quotes ( ' '). You can specify several name and value pair arguments in any order as `Name1,Value1,...,NameN,ValueN`.

### **'WriteMode'**

One of these strings:

- `overwrite`
- `append`

**Default:** overwrite

**'Compression'**

One of these strings:

- none
- gzip
- rice
- hcompress
- plio

**Default:** none

## Examples

Create a FITS file containing the red channel of an RGB image.

```
X = imread('ngc6543a.jpg');
R = X(:,:,1);
fitswrite(R,'myfile.fits');
fitsdisp('myfile.fits');
```

Create a FITS file with three images constructed from the channels of an RGB image.

```
X = imread('ngc6543a.jpg');
R = X(:,:,1); G = X(:,:,2); B = X(:,:,3);
fitswrite(R,'myfile.fits');
fitswrite(G,'myfile.fits','writemode','append');
fitswrite(B,'myfile.fits','writemode','append');
fitsdisp('myfile.fits');
```

## References

For copyright information, see the `cfitsiocopyright.txt` file.

## See Also

`fitsinfo` | `fitsread`

# fix

---

**Purpose** Round toward zero

**Syntax** `B = fix(A)`

**Description** `B = fix(A)` rounds the elements of `A` toward zero, resulting in an array of integers. For complex `A`, the imaginary and real parts are rounded independently.

**Examples** `a = [-1.9, -0.2, 3.4, 5.6, 7.0, 2.4+3.6i]`

```
a =
Columns 1 through 4
-1.9000 -0.2000 3.4000 5.6000

Columns 5 through 6
7.0000 2.4000 + 3.6000i
```

```
fix(a)
```

```
ans =
Columns 1 through 4
-1.0000 0 3.0000 5.0000

Columns 5 through 6
7.0000 2.0000 + 3.0000i
```

**See Also** `ceil` | `floor` | `round`

## Purpose

Summary of classes in MATLAB Fixtures Interface

## Description

Fixtures ease creation of setup and teardown code. The `matlab.unittest.fixtures` package consists of the following customized MATLAB fixtures.

`matlab.unittest.fixtures.CurrentFolderFixture` Fixture for changing current working folder

`matlab.unittest.fixtures.Fixture` Interface class for test fixtures

`matlab.unittest.fixtures.PathFixture` Fixture for adding a folder to the MATLAB path

`matlab.unittest.fixtures.SuppressedWarningsFixture` Suppress display of warnings

`matlab.unittest.fixtures.TemporaryFolderFixture` Creating a temporary folder

## Related Examples

- “Write Tests Using Shared Fixtures”
- “Create Basic Custom Fixture”
- “Create Advanced Custom Fixture”

# matlab.unittest.fixtures.CurrentFolderFixture

---

**Purpose** Fixture for changing current working folder

**Description** The `CurrentFolderFixture` class provides a fixture for changing the current working folder. When the test framework sets up the fixture, it changes the working folder. When the test framework tears down the fixture, it restores the working folder to its previous state.

**Construction** `matlab.unittest.fixtures.CurrentFolderFixture(folder)` constructs a fixture for changing the current working folder to `folder`.

## Input Arguments

### **folder - Folder to make the current working folder**

string

Folder to make the current working folder, specified as a string. MATLAB throws an error if `folder` does not exist.

**Properties** **Folder**

Folder to make the current working folder, specified as a string in the `folder` input argument.

**Copy Semantics** Handle. To learn how handle classes affect copy operations, see Copying Objects in the MATLAB documentation.

## Examples **Create Fixture to Change Current Working Folder**

Create the following `changeFolderFixtureTest` class definition on your MATLAB path. This example assumes that the subfolder `helperFiles` exists in your working folder. Create the `changeToFolder` in your working folder if it does not exist.

The `test1` function includes a call to `pwd` to demonstrate the current path changed to the `helperFiles` folder.

```
classdef changeFolderFixtureTest < matlab.unittest.TestCase
 methods(Test)
```

# matlab.unittest.fixtures.CurrentFolderFixture

---

```
function test1(testCase)
 import matlab.unittest.fixtures.CurrentFolderFixture;

 changeToFolder = 'helperFiles';
 testCase.applyFixture(CurrentFolderFixture ...
 (changeToFolder));
 pwd
end
end
end
```

At the command prompt, run the test. For the purposes of this example, call `pwd` before and after `run` to show the fixture was properly torn down and the path returned to the pre-test state.

```
currentFolderBeforeTest = pwd
run(changeFolderFixtureTest);
currentFolderAfterTest = pwd

currentFolderBeforeTest =
H:\Documents\doc_examples

Running changeFolderFixtureTest

ans =

H:\Documents\doc_examples\helperFiles

.
Done changeFolderFixtureTest

currentFolderAfterTest =
H:\Documents\doc_examples
```

# matlab.unittest.fixtures.CurrentFolderFixture

---

## See Also

[matlab.unittest.fixtures.PathFixture](#) |  
[matlab.unittest.TestCase.applyFixture](#) |  
[matlab.unittest.fixtures](#)

## Related Examples

## Concepts



## Purpose

Interface class for test fixtures

## Description

The `Fixture` interface class is the means by which test authors create custom fixtures. Fixtures configure the environment state required for tests.

Classes deriving from the `Fixture` interface must implement the `setup` method. This method executes the changes to the environment. A fixture should restore the environment to its initial state when it is torn down. To restore the environment, use the `addTeardown` method in the `setup` method or implement the fixture's `teardown` method.

Subclasses can set the `SetupDescription` and `TeardownDescription` properties in their constructors to provide descriptions for the actions performed by the `setup` and `teardown` methods. The testing framework can display these descriptions when setting up and tearing down the fixture.

A class that derives from `Fixture` must implement the `isCompatible` method if its constructor accepts any input arguments or is otherwise configurable. `Fixture` subclasses use this method to define a notion of interchangeability of fixtures. Two `matlab.unittest.fixtures` instances of the same class are considered to be interchangeable if the `isCompatible` method returns `true`. The `TestRunner` uses the result of `isCompatible` to determine whether two fixture instances of the same class correspond to the same shared test fixture state.

## Properties

### **SetupDescription**

Description of fixture setup actions, specified as a string. The `SetupDescription` property describes the actions the fixture performs when the testing framework invokes the fixture's `setup` method.

### **TeardownDescription**

Description of fixture teardown actions, specified as a string. The `TeardownDescription` property describes the actions the fixture performs when the testing framework invokes the fixture's `teardown` method.

# matlab.unittest.fixtures.Fixture

---

## Methods

|              |                                                                 |
|--------------|-----------------------------------------------------------------|
| addTeardown  | Dynamically add teardown routine                                |
| isCompatible | Determine if two fixtures of the same class are interchangeable |
| setup        | Set up fixture                                                  |
| teardown     | Tear down fixture                                               |

## Events

|                      |                                                                                                                                |
|----------------------|--------------------------------------------------------------------------------------------------------------------------------|
| AssertionFailed      | Triggered upon failing assertion. A <code>QualificationEventData</code> object is passed to listener callback functions.       |
| AssertionPassed      | Triggered upon passing assertion. A <code>QualificationEventData</code> object is passed to listener callback functions.       |
| AssumptionFailed     | Triggered upon failing assumption. A <code>QualificationEventData</code> object is passed to listener callback functions.      |
| AssumptionPassed     | Triggered upon passing assumption. A <code>QualificationEventData</code> object is passed to listener callback functions.      |
| FatalAssertionFailed | Triggered upon failing fatal assertion. A <code>QualificationEventData</code> object is passed to listener callback functions. |

|                                   |                                                                                                                                                           |
|-----------------------------------|-----------------------------------------------------------------------------------------------------------------------------------------------------------|
| <code>FatalAssertionPassed</code> | Triggered upon passing fatal assertion. A <code>QualificationEventData</code> object is passed to listener callback functions.                            |
| <code>ExceptionThrown</code>      | Triggered by the <code>TestRunner</code> when an exception is thrown. An <code>ExceptionEventData</code> object is passed to listener callback functions. |

## Copy Semantics

Handle. To learn how handle classes affect copy operations, see Copying Objects in the MATLAB documentation.

## See Also

`matlab.unittest.fixtures` |  
`matlab.unittest.TestCase.getSharedTestFixtures` |  
`matlab.unittest.TestCase.applyFixture` | `addTeardown` |  
`matlab.unittest.qualifications.QualificationEventData` |  
`matlab.unittest.qualifications.ExceptionEventData`

## Related Examples

- “Create Basic Custom Fixture”
- “Create Advanced Custom Fixture”

## Concepts

# matlab.unittest.fixtures.Fixture.setup

---

|                         |                                                                                                                                                                                                                                                                                                                                                                                                                                                                                                            |
|-------------------------|------------------------------------------------------------------------------------------------------------------------------------------------------------------------------------------------------------------------------------------------------------------------------------------------------------------------------------------------------------------------------------------------------------------------------------------------------------------------------------------------------------|
| <b>Purpose</b>          | Set up fixture                                                                                                                                                                                                                                                                                                                                                                                                                                                                                             |
| <b>Syntax</b>           | <code>setup(f)</code>                                                                                                                                                                                                                                                                                                                                                                                                                                                                                      |
| <b>Description</b>      | <code>setup(f)</code> sets up a fixture by performing the defined environment modifications. Classes deriving from the <code>Fixture</code> interface must implement the <code>setup</code> method. This method executes the changes to the environment. A fixture should restore the environment to its initial state when it is torn down. To restore the environment, use the <code>addTeardown</code> method in the <code>setup</code> method or implement the fixture's <code>teardown</code> method. |
| <b>Input Arguments</b>  | <b>f</b><br>matlab.unittest.fixtures.Fixture instance                                                                                                                                                                                                                                                                                                                                                                                                                                                      |
| <b>See Also</b>         | <code>matlab.unittest.fixtures.Fixture</code>  <br><code>matlab.unittest.fixtures.Fixture.teardown</code>  <br><code>matlab.unittest.fixtures.Fixture.addTeardown</code>                                                                                                                                                                                                                                                                                                                                   |
| <b>Related Examples</b> | <ul style="list-style-type: none"><li>• “Create Basic Custom Fixture”</li><li>• “Create Advanced Custom Fixture”</li></ul>                                                                                                                                                                                                                                                                                                                                                                                 |

# matlab.unittest.fixtures.Fixture.teardown

---

|                         |                                                                                                                                                                                            |
|-------------------------|--------------------------------------------------------------------------------------------------------------------------------------------------------------------------------------------|
| <b>Purpose</b>          | Tear down fixture                                                                                                                                                                          |
| <b>Syntax</b>           | <code>teardown(f)</code>                                                                                                                                                                   |
| <b>Description</b>      | <code>teardown(f)</code> tears down a fixture by performing the defined actions to restore the environment to the initial state.                                                           |
| <b>Input Arguments</b>  | <b>f</b><br>matlab.unittest.fixtures.Fixture instance                                                                                                                                      |
| <b>Alternatives</b>     | Instead of defining a <code>teardown</code> method, you can define <code>teardown</code> actions within the <code>setup</code> method by implementing the <code>addTeardown</code> method. |
| <b>See Also</b>         | <code>matlab.unittest.fixtures.Fixture</code>  <br><code>matlab.unittest.fixtures.Fixture.addTeardown</code>  <br><code>matlab.unittest.fixtures.Fixture.setup</code>                      |
| <b>Related Examples</b> | <ul style="list-style-type: none"><li>• “Create Basic Custom Fixture”</li><li>• “Create Advanced Custom Fixture”</li></ul>                                                                 |

# matlab.unittest.fixtures.Fixture.addTeardown

---

**Purpose** Dynamically add teardown routine

**Syntax** `addTeardown(f,tearDownFcn)`  
`addTeardown(f,tearDownFcn,arg1,...,argN)`

**Description** `addTeardown(f,tearDownFcn)` adds the `tearDownFcn` function handle that defines fixture teardown code to the `Fixture` instance. The teardown code is executed in the reverse order to which it is added. This is known as LIFO (or Last-In-First-Out).

`addTeardown(f,tearDownFcn,arg1,...,argN)` provides input arguments to the `tearDownFcn`.

**Input Arguments** **f**  
matlab.unittest.fixtures.Fixture instance

**tearDownFcn**  
Function that defines the fixture teardown code, specified as a function handle.

**arg1,...,argN**  
Input arguments required by `tearDownFcn`, specified by any type. The argument type is specified by the `tearDownFcn` function argument list.

**Alternatives** Instead of defining teardown actions within the `setup` method by implementing the `addTeardown` method, you can implement the `teardown` method.

**See Also** `matlab.unittest.fixtures.Fixture` |  
`matlab.unittest.fixtures.Fixture.teardown` |  
`matlab.unittest.fixtures.Fixture.setup`

**Related Examples**

- “Create Advanced Custom Fixture”

# matlab.unittest.fixtures.Fixture.isCompatible

---

**Purpose** Determine if two fixtures of the same class are interchangeable

**Syntax** `TF = isCompatible(f1, f2)`

**Description** `TF = isCompatible(f1, f2)` determines if two fixtures of the same class are interchangeable. The `isCompatible` method returns either logical 1 (true) or logical 0 (false).

A class that derives from `Fixture` must implement the `isCompatible` method if its constructor accepts any input arguments or is otherwise configurable. `Fixture` subclasses use this method to define a notion of interchangeability of fixtures. Two `matlab.unittest.fixtures` instances of the same class are considered to be interchangeable if the `isCompatible` method returns `true`. The `TestRunner` uses the result of `isCompatible` to determine whether two fixture instances of the same class correspond to the same shared test fixture state. The test framework always calls the `isCompatible` method with two fixture instances of the same class, so the fixture author does not need to implement code to handle the case where the second fixture is a different `fixtures` class.

**Input Arguments**

|          |                                                        |
|----------|--------------------------------------------------------|
| <b>f</b> | <code>matlab.unittest.fixtures.Fixture</code> instance |
|----------|--------------------------------------------------------|

## Attributes

|        |           |
|--------|-----------|
| Access | Protected |
|--------|-----------|

To learn about attributes of methods, see [Method Attributes](#) in the [MATLAB Object-Oriented Programming](#) documentation.

**See Also** `matlab.unittest.fixtures.Fixture`

## Related Examples

- “Create Advanced Custom Fixture”

# matlab.unittest.fixtures.PathFixture

---

**Purpose** Fixture for adding a folder to the MATLAB path

**Description** The `PathFixture` class provides a fixture for adding a folder to the MATLAB path. When the test framework sets up the fixture, it adds the specified folder to the path. When the test framework tears down the fixture, it restores the MATLAB path to its previous state.

**Construction** `matlab.unittest.fixtures.PathFixture(folder)` constructs a fixture for adding a folder to the MATLAB path. When the test framework sets up the fixture, it adds `folder` to the path. When it tears down the fixture, it restores the MATLAB path to its previous state.

## Input Arguments

### **folder - Folder to add to the MATLAB path**

string

Folder to add to the MATLAB path, specified as a string. MATLAB throws an error if `folder` does not exist.

**Properties** **Folder**

Folder to add to the MATLAB path, specified as a string in the `folder` input argument.

**Copy Semantics** Handle. To learn how handle classes affect copy operations, see Copying Objects in the MATLAB documentation.

**Examples** **Add Directory to MATLAB Path for Testing**

Create the following `addPathFixtureTest` class definition on your MATLAB path. This example assumes that the subfolder, `helperFiles`, exists in your working folder. If it does not, define `addFolder` to be a directory that exists within your current folder.

```
classdef addPathFixtureTest < matlab.unittest.TestCase
 methods(Test)
 function test1(testCase)
```



```
import matlab.unittest.fixtures.PathFixture;

addFolder = 'helperFiles';
f = testCase.applyFixture(PathFixture(addFolder));
disp(['Added to path: ' f.Folder])
end
end
end
```

At the command prompt, run the test.

```
run(addPathFixtureTest);
```

```
Running addPathFixtureTest
Added to path: H:\Documents\doc_examples\helperFiles
.
Done addPathFixtureTest
```

---

After the tests finish running, the framework removes the folder from the path.

## Add Directory to Path Using Shared Test Fixture

Create the following `sharedAddPathFixtureTest` class definition on your MATLAB path. This example assumes that the subfolder, `helperFiles`, exists in your working folder.

```
classdef (SharedTestFixtures={ ...
 matlab.unittest.fixtures.PathFixture('helperFiles')}) ...
 sharedAddPathFixtureTest < matlab.unittest.TestCase
 methods(Test)
 function test1(testCase)
 f = testCase.getSharedTestFixtures;
 disp(['Added to path: ' f.Folder])
 end
 end
end
```

# matlab.unittest.fixtures.PathFixture

---

At the command prompt, run the test.

```
run(sharedAddPathFixtureTest);
```

```
Setting up PathFixture
```

```
Done setting up PathFixture: Added 'H:\Documents\doc_examples\helperFiles' to the path.
```

```

```

```
Running sharedAddPathFixtureTest
```

```
Added to path: H:\Documents\doc_examples\helperFiles
```

```
.
```

```
Done sharedAddPathFixtureTest
```

```

```

```
Tearing down PathFixture
```

```
Done tearing down PathFixture: Restored the path to its original state.
```

```

```

After the tests finish running, the framework removes the folder from the path.

## See Also

```
matlab.unittest.fixtures.CurrentFolderFixture
| matlab.unittest.TestCase.applyFixture |
matlab.unittest.fixtures
```

## Related Examples

## Concepts

# matlab.unittest.fixtures.SuppresseWarningsFixture

|                       |                                                                                                                                                                                                                                                                                                                                                                                                     |
|-----------------------|-----------------------------------------------------------------------------------------------------------------------------------------------------------------------------------------------------------------------------------------------------------------------------------------------------------------------------------------------------------------------------------------------------|
| <b>Purpose</b>        | Fixture to suppress display of warnings                                                                                                                                                                                                                                                                                                                                                             |
| <b>Description</b>    | The SuppresseWarningsFixture class provides a fixture to suppress the display of warnings. When set up, SuppresseWarningsFixture disables one or more specified warnings. When torn down, the fixture restores the states of warnings to their previous values.                                                                                                                                     |
| <b>Construction</b>   | <code>matlab.unittest.fixtures.SuppresseWarningsFixture(warnIDs)</code> constructs a fixture to suppress the display of one or more warnings.<br><b>Input Arguments</b><br><b>warnIDs - Identifier for warnings disabled when the fixture is set up</b><br>string   cell array of strings<br>Warning identifiers for the warnings to be suppressed, specified as a string or cell array of strings. |
| <b>Properties</b>     | <b>Warnings</b><br>Warning identifiers describing warnings to suppress specified as a cell array of strings in the warnings input argument.                                                                                                                                                                                                                                                         |
| <b>Copy Semantics</b> | Handle. To learn how handle classes affect copy operations, see Copying Objects in the MATLAB documentation.                                                                                                                                                                                                                                                                                        |
| <b>Examples</b>       | <b>Create Fixture to Suppress Warnings</b><br>Suppress the warning that occurs when you try to remove a folder from the search path that is not on the search path.<br>Remove the folder, <code>folderthatisonpath</code> from your path, assuming it does not exist.<br><pre>rmpath('folderthatisonpath');</pre><br>Warning: "folderthatisonpath" not found in path.<br>> In rmpath at 58          |

# matlab.unittest.fixtures.SuppresseWarningsFixture

---

A warning appears because `rmpath` cannot find the folder.

Suppress the warning during testing by creating the following `suppressWarningsTest` class definition on your MATLAB path.

```
classdef suppressWarningsTest < matlab.unittest.TestCase
 methods(Test)
 function test1(testCase)
 import matlab.unittest.fixtures.SuppresseWarningsFixture;

 testCase.applyFixture(...
 SuppresseWarningsFixture('MATLAB:rmpath:DirNotFound'));

 % would otherwise cause warning
 rmpath('folderthatisnotonpath');
 end
 end
end
```

At the command prompt, run the test. For the purposes of this example, call `rmpath` before and after running the test to show the warning is not suppressed outside execution of the test.

```
rmpath('folderthatisnotonpath');
run(suppressWarningsTest);
rmpath('folderthatisnotonpath');
```

```
Warning: "folderthatisnotonpath" not found in path.
> In rmpath at 58
Running suppressWarningsTest
.
Done suppressWarningsTest
```

---

```
Warning: "folderthatisnotonpath" not found in path.
> In rmpath at 58
```

# matlab.unittest.fixtures.SuppresseWarningsFixture

---

Note that the call to `rmpath` within `suppressWarningsTest` does not result in a warning.

## See Also

`matlab.unittest.TestCase.applyFixture` | `warning` |  
`matlab.unittest.fixtures`

## Concepts

# matlab.unittest.fixtures.TemporaryFolderFixture

---

**Purpose** Fixture for creating a temporary folder

**Description** The `matlab.unittest.fixtures.TemporaryFolderFixture` provides a fixture to create a temporary folder. When the testing framework sets up the fixture, it creates the temporary folder. When it tears down the fixture, it deletes the folder and all its contents. Before it deletes the folder, the fixture clears from memory the definitions of any MATLAB-files, P-files, and MEX-files that are defined in the temporary folder.

**Construction** `matlab.unittest.fixtures.TemporaryFolderFixture` constructs a fixture for creating a temporary folder.

`matlab.unittest.fixtures.TemporaryFolderFixture(Name,Value)` constructs a fixture for creating a temporary folder with additional options specified by one or more `Name,Value` pair arguments.

## Input Arguments

### Name-Value Pair Arguments

Specify optional comma-separated pairs of `Name,Value` arguments. `Name` is the argument name and `Value` is the corresponding value. `Name` must appear inside single quotes ( ' '). You can specify several name and value pair arguments in any order as `Name1,Value1,...,NameN,ValueN`.

### PreservingOnFailure - Preservation state of temporary folder and contents after test failure

`true`

Indicator of whether the temporary folder and its contents are preserved in the event of a test failure, specified as logical `true`. This property is `false` by default. You can specify it as `true` during fixture construction.

### Data Types

logical

### WithSuffix - Suffix for temporary folder name

string (default)

# matlab.unittest.fixtures.TemporaryFolderFixture

---

Suffix for temporary folder name, specified as a string.

## Properties

### Folder

Absolute path of the folder created by the fixture, specified as a string.

### PreserveOnFailure

Indicator of whether the temporary folder and its contents are preserved in the event of a test failure. This property is `logical(0)` or `logical(1)`. It is `logical(0)` by default but is set to `logical(1)` if the 'PreservingOnFailure' input value is set to true during fixture construction.

### Suffix

Suffix used for temporary folder, specified as a string in the Name, Value pair argument, 'WithSuffix'.

## Copy Semantics

Handle. To learn how handle classes affect copy operations, see Copying Objects in the MATLAB documentation.

## Examples

### Create Temporary Folder Fixture

Create the following `tempFolderFixtureTest` class definition on your MATLAB path.

```
classdef tempFolderFixtureTest < matlab.unittest.TestCase
 methods(Test)
 function test1(testCase)
 import matlab.unittest.fixtures.TemporaryFolderFixture;

 tempFolder = testCase.applyFixture(TemporaryFolderFixture);

 disp(['The temporary folder: ' tempFolder.Folder])
 end
 end
end
```

# matlab.unittest.fixtures.TemporaryFolderFixture

---

At the command prompt, run the test.

```
run(tempFolderFixtureTest);

Running tempFolderFixtureTest
The temporary folder: C:\Temp\tpfb1ae2cf_c9de_4de3_9557_00d52bfcc1b2
.
Done tempFolderFixtureTest
```

The name of the temporary folder varies.

## Create Temporary Folder Fixture Persisting Through Test Failure

Create the following `anotherTempFolderFixtureTest` class definition on your MATLAB path. For the purposes of this example, the `test1` function contains an assertion that causes test failure.

```
classdef anotherTempFolderFixtureTest < matlab.unittest.TestCase
 methods(Test)
 function test1(testCase)
 import matlab.unittest.fixtures.TemporaryFolderFixture;

 testCase.applyFixture(TemporaryFolderFixture(...
 'PreservingOnFailure',true,'WithSuffix','TestData'));

 % Failed assertion, perserved temporary folder
 testCase.assertEqual(1,2);
 end
 end
end
```

At the command prompt, run the test.

```
run(anotherTempFolderFixtureTest);

Running anotherTempFolderFixtureTest
```



# matlab.unittest.fixtures.TemporaryFolderFixture

---

```
=====
Assertion failed in anotherTempFolderFixtureTest/test1.
The remainder of the test method will not run to completion.

Framework Diagnostic:

assertEqual failed.
--> NumericComparator failed.
 --> The values are not equal using "isequaln".

Actual Value:
 1
Expected Value:
 2

Stack Information:

In H:\Documents\doc_examples\anotherTempFolderFixtureTest.m (anotherTempFolderFixtureTest.test1)
=====
[Terse] Diagnostic logged (20131003T133246):
Because of a failure in the test using the TemporaryFolderFixture, the following folder will not be
C:\Temp\tp70976704_7e39_48b8_90ae_f121bbfaf877TestData

.
Done anotherTempFolderFixtureTest

Failure Summary:

Name Failed Incomplete Reason(s)
=====
anotherTempFolderFixtureTest/test1 X X Failed by assertion.
```

The test failed and the temporary folder persists.  
You can open the temporary folder, shown here as

# matlab.unittest.fixtures.TemporaryFolderFixture

---

C:\Temp\tp70976704\_7e39\_48b8\_90ae\_f121bbfaf877TestData, and examine any contents.

## See Also

[matlab.unittest.fixtures](#) |  
[matlab.unittest.fixtures.PathFixture](#) |  
[matlab.unittest.fixtures.CurrentFolderFixture](#) |  
[matlab.unittest.TestCase.applyFixture](#)

## Concepts

|                         |                                                                                                                                                                                                                                                                                                                                                                                                                                                              |
|-------------------------|--------------------------------------------------------------------------------------------------------------------------------------------------------------------------------------------------------------------------------------------------------------------------------------------------------------------------------------------------------------------------------------------------------------------------------------------------------------|
| <b>Purpose</b>          | Largest consecutive integer in floating-point format                                                                                                                                                                                                                                                                                                                                                                                                         |
| <b>Syntax</b>           | <pre>f = flintmax f = flintmax(precision)</pre>                                                                                                                                                                                                                                                                                                                                                                                                              |
| <b>Description</b>      | <p>f = flintmax returns the largest consecutive integer in IEEE® double precision, which is 2<sup>53</sup>. Above this value, double-precision format does not have integer precision, and not all integers can be represented exactly.</p> <p>f = flintmax(precision) returns the largest consecutive integer in IEEE single or double precision. flintmax returns single(2<sup>24</sup>) for single precision and 2<sup>53</sup> for double precision.</p> |
| <b>Input Arguments</b>  | <p><b>precision - Floating-point precision type</b><br/>'double' (default)   'single'</p> <p>Floating-point precision type, specified as 'double' or 'single'.</p> <p><b>Data Types</b><br/>char</p>                                                                                                                                                                                                                                                         |
| <b>Output Arguments</b> | <p><b>f - Largest consecutive integer in floating-point format</b><br/>scalar constant</p> <p>Largest consecutive integer in floating-point format returned as a scalar constant. This constant is 2<sup>53</sup> for double precision and single(2<sup>24</sup>) for single precision.</p>                                                                                                                                                                  |
| <b>Examples</b>         | <p><b>Double Precision</b></p> <p>Return the largest consecutive integer in IEEE double precision.</p> <pre>format long e f = flintmax  f =</pre>                                                                                                                                                                                                                                                                                                            |

```
9.007199254740992e+15
```

This is  $2^{53}$ .

## Single Precision

Return the largest consecutive integer in IEEE single precision.

```
f = flintmax('single')
```

```
f =
```

```
16777216
```

This is `single(224)`.

Check the class of `f`.

```
class(f)
```

```
ans =
```

```
single
```

## Limit of Integer Single Precision

Above the value returned by `flintmax('single')`, not all integers can be represented exactly with single precision.

Return the largest consecutive integer in IEEE single precision.

```
f = flintmax('single')
```

```
f =
```

```
16777216
```

This is `single(224)`.

Add 1 to the value returned from `flintmax`.

```
f1 = f + 1
```

```
f1 =
```

```
16777216
```

f1 is the same as f.

```
isequal(f,f1)
```

```
ans =
```

```
1
```

Add 2 to the value returned from `flintmax`.

```
f2 = f + 2
```

```
f2 =
```

```
16777218
```

16777218 is represented exactly in single precision while 16777217 is not.

## See Also

[eps](#) | [realmax](#) | [intmax](#) | [format](#)

## Concepts

- “Floating-Point Numbers”

# flip

---

**Purpose** Flip order of elements

**Syntax**  
`B = flip(A)`  
`B = flip(A,dim)`

**Description** `B = flip(A)` returns array `B` the same size as `A`, but with the order of the elements reversed. The dimension that is reordered in `B` depends on the shape of `A`:

- If `A` is vector, then `flip(A)` reverses the order of the elements along the length of the vector.
- If `A` is a matrix, then `flip(A)` reverses the elements in each column.
- If `A` is an N-D array, then `flip(A)` operates on the first dimension of `A` in which the size value is not 1.

`B = flip(A,dim)` reverses the order of the elements in `A` along dimension `dim`. For example, if `A` is a matrix, then `flip(A,1)` reverses the elements in each column, and `flip(A,2)` reverses the elements in each row.

## Input Arguments

**A - Input array**  
vector | matrix | array | cell array | table

Input array, specified as a vector, matrix, array, cell array, or table.

**Example:** `[1 2 3 4]`

**Example:** `['abcde']`

**Example:** `[1 2; 3 4]`

**Example:** `{'abcde',[1 2 3]}`

**Example:** `table(rand(1,5),rand(1,5))`

**dim - Dimension to operate along**  
positive integer scalar

Dimension to operate along, specified as a positive integer scalar. If no value is specified, the default is the first array dimension whose size does not equal 1.

The following illustration shows the difference between `dim=1` and `dim=2` when `A` is a matrix.

|   |   |   |
|---|---|---|
| 1 | 2 | 3 |
| 4 | 5 | 6 |

A

|   |   |   |
|---|---|---|
| 4 | 5 | 6 |
| 1 | 2 | 3 |

flip(A,1)

|   |   |   |
|---|---|---|
| 3 | 2 | 1 |
| 6 | 5 | 4 |

flip(A,2)

## Examples

### Flip String of Characters

```
A = 'no word, no bond, row on.'
```

```
B = flip(A)
```

```
B =
```

```
.no wor ,dnob on ,drow on
```

### Flip Column Vector

```
A = [1;2;3];
```

```
B = flip(A)
```

```
B =
```

```
3
```

```
2
```

```
1
```

### Flip Matrix

Create a diagonal matrix, `A`.

# flip

---

```
A = diag([100 200 300])
```

```
A =
```

```
 100 0 0
 0 200 0
 0 0 300
```

Flip A without specifying the dim argument.

```
B = flip(A)
```

```
B =
```

```
 0 0 300
 0 200 0
 100 0 0
```

Now, flip A along the second dimension.

```
B = flip(A,2)
```

```
B =
```

```
 0 0 100
 0 200 0
 300 0 0
```

## Flip N-D Array

Create a 1-by-3-by-2 array.

```
A = zeros(1,3,2);
A(:,:,1) = [1 2 3];
A(:,:,2) = [4 5 6];
A
```

```
A(:,:,1) =
```



```
1 2 3
```

```
A(:,:,2) =
```

```
4 5 6
```

Flip A without specifying the dim argument.

```
B = flip(A)
```

```
B(:,:,1) =
```

```
3 2 1
```

```
B(:,:,2) =
```

```
6 5 4
```

Now, flip A along the third dimension.

```
B = flip(A,3)
```

```
B(:,:,1) =
```

```
4 5 6
```

```
B(:,:,2) =
```

```
1 2 3
```

### Flip Cell Array

Create a 3-by-2 cell array.

```
A = {'foo',1000; 999,true; 'aaa','bbb'}
```

# flip

---

```
A =

 'foo' [1000]
 [999] [1]
 'aaa' 'bbb'
```

Flip A without specifying the `dim` argument.

```
B = flip(A)
```

```
B =

 'aaa' 'bbb'
 [999] [1]
 'foo' [1000]
```

Now, flip A along the second dimension.

```
B = flip(A,2)
```

```
B =

 [1000] 'foo'
 [1] [999]
 'bbb' 'aaa'
```

## See Also

[fliplr](#) | [flipud](#) | [permute](#) | [rot90](#) | [transpose](#)

## Purpose

Flip array along specified dimension

`flipdim` will be removed in a future release. Use `flip` instead.

## Syntax

```
B = flipdim(A,dim)
```

## Description

`B = flipdim(A,dim)` returns `A` with dimension `dim` flipped.

When the value of `dim` is 1, the array is flipped row-wise down. When `dim` is 2, the array is flipped columnwise left to right. `flipdim(A,1)` is the same as `flipud(A)`, and `flipdim(A,2)` is the same as `fliplr(A)`.

## Examples

`flipdim(A,1)` where

`A =`

```
1 4
2 5
3 6
```

produces

```
3 6
2 5
1 4
```

## See Also

`fliplr` | `flipud` | `permute` | `rot90` | `flip`

# fliplr

---

**Purpose** Flip array left to right

**Syntax** `B = fliplr(A)`

**Description** `B = fliplr(A)` returns `A` with its columns flipped in the left-right direction (that is, about a vertical axis).

If `A` is a row vector, then `fliplr(A)` returns a vector of the same length with the order of its elements reversed. If `A` is a column vector, then `fliplr(A)` simply returns `A`. For multidimensional arrays, `fliplr` operates on the planes formed by the first and second dimensions.

**Input Arguments** **A - Input array**  
vector | matrix | array | cell array | categorical array | table

Input array, specified as a vector, matrix, array, cell array, categorical array, or table of any data type.

**Complex Number Support:** Yes

**Examples** **Flip Row Vector**

Create a row vector.

```
A = 1:10
```

```
A =
```

```
 1 2 3 4 5 6 7 8 9 10
```

Use `fliplr` to flip the elements of `A` in the horizontal direction.

```
B = fliplr(A)
```

```
B =
```

```
 10 9 8 7 6 5 4 3 2 1
```

The order of the elements in `B` is reversed compared to `A`.

## Flip Cell Array of Strings

Create a 3-by-3 cell array of strings.

```
A = {'a' 'b' 'c'; 'd' 'e' 'f'; 'g' 'h' 'i'}
```

```
A =
```

```
 'a' 'b' 'c'
 'd' 'e' 'f'
 'g' 'h' 'i'
```

Change the order of the columns in the horizontal direction by using `fliplr`.

```
B = fliplr(A)
```

```
B =
```

```
 'c' 'b' 'a'
 'f' 'e' 'd'
 'i' 'h' 'g'
```

The order of the first and third columns of A is switched in B, while the second column remains unchanged.

## Flip Multidimensional Array

Create a multidimensional array.

```
A = cat(3, [1 2; 3 4], [5 6; 7 8])
```

```
A(:,:,1) =
```

```
 1 2
 3 4
```

```
A(:,:,2) =
```

# fliplr

---

```
5 6
7 8
```

A is an array of size 2-by-2-by-2.

Flip the elements on each page of A in the horizontal direction.

```
B = fliplr(A)
```

```
B(:,:,1) =
```

```
2 1
4 3
```

```
B(:,:,2) =
```

```
6 5
8 7
```

The result, B, is the same size as A, but the horizontal order of the elements is flipped. The operation flips the elements on each page independently.

## Tips

- `fliplr(A)` is equivalent to `flip(A,2)`.
- Use the `flipud` function to flip arrays in the vertical direction (that is, about a horizontal axis).
- The `flip` function can flip arrays in any direction.

## See Also

`flip` | `flipud` | `rot90`

|                        |                                                                                                                                                                                                                                                                                                                                                                                                                                                                                                                    |
|------------------------|--------------------------------------------------------------------------------------------------------------------------------------------------------------------------------------------------------------------------------------------------------------------------------------------------------------------------------------------------------------------------------------------------------------------------------------------------------------------------------------------------------------------|
| <b>Purpose</b>         | Flip array up to down                                                                                                                                                                                                                                                                                                                                                                                                                                                                                              |
| <b>Syntax</b>          | <code>B = flipud(A)</code>                                                                                                                                                                                                                                                                                                                                                                                                                                                                                         |
| <b>Description</b>     | <p><code>B = flipud(A)</code> returns <code>A</code> with its rows flipped in the up-down direction (that is, about a horizontal axis).</p> <p>If <code>A</code> is a column vector, then <code>flipud(A)</code> returns a vector of the same length with the order of its elements reversed. If <code>A</code> is a row vector, then <code>flipud(A)</code> simply returns <code>A</code>. For multidimensional arrays, <code>flipud</code> operates on the planes formed by the first and second dimensions.</p> |
| <b>Input Arguments</b> | <p><b>A - Input array</b><br/>vector   matrix   array   cell array   categorical array   table</p> <p>Input array, specified as a vector, matrix, array, cell array, categorical array, or table of any data type.</p> <p><b>Complex Number Support:</b> Yes</p>                                                                                                                                                                                                                                                   |
| <b>Examples</b>        | <p><b>Flip Column Vector</b></p> <p>Create a column vector.</p> <pre>A=(1:10)'</pre> <p>A =</p> <pre>1 2 3 4 5 6 7 8 9 10</pre>                                                                                                                                                                                                                                                                                                                                                                                    |

Use `flipud` to flip the elements of `A` in the vertical direction.

```
B = flipud(A)
```

```
B =
```

```
10
 9
 8
 7
 6
 5
 4
 3
 2
 1
```

The order of the elements in `B` is reversed compared to `A`.

## Flip Cell Array of Strings

Create a 3-by-3 cell array of strings.

```
A = {'a' 'b' 'c'; 'd' 'e' 'f'; 'g' 'h' 'i'}
```

```
A =
```

```
'a' 'b' 'c'
'd' 'e' 'f'
'g' 'h' 'i'
```

Change the order of the rows in the vertical direction by using `flipud`.

```
B = flipud(A)
```

```
B =
```

```
'g' 'h' 'i'
'd' 'e' 'f'
```



```
'a' 'b' 'c'
```

The order of the first and third rows of A is switched in B, while the second row remains unchanged.

### Flip Multidimensional Array

Create a multidimensional array.

```
A = cat(3, [1 2; 3 4], [5 6; 7 8])
```

```
A(:,:,1) =
```

```
 1 2
 3 4
```

```
A(:,:,2) =
```

```
 5 6
 7 8
```

A is an array of size 2-by-2-by-2.

Flip the elements on each page of A in the vertical direction.

```
B = flipud(A)
```

```
B(:,:,1) =
```

```
 3 4
 1 2
```

```
B(:,:,2) =
```

```
 7 8
 5 6
```

# flipud

---

The result, `B`, is the same size as `A`, but the vertical order of the elements is flipped. The operation flips the elements on each page independently.

## Tips

- `flipud(A)` is equivalent to `flip(A,1)`.
- Use the `flip1r` function to flip arrays in the horizontal direction (that is, about a vertical axis).
- The `flip` function can flip arrays in any direction.

## See Also

`flip1r` | `rot90` | `flip`

**Purpose** Round toward negative infinity

**Syntax** `B = floor(A)`

**Description** `B = floor(A)` rounds the elements of `A` to the nearest integers less than or equal to `A`. For complex `A`, the imaginary and real parts are rounded independently.

**Examples**

```
a = [-1.9 -0.2 3.4 5.6 7.0 2.4+3.6i];

floor(a)

ans =
-2.0000 -1.0000 3.0000 5.0000 7.0000 2.0000 + 3.0000i
```

**See Also** `ceil` | `fix` | `round`

# flow

---

**Purpose** Simple function of three variables

**Syntax**

```
v = flow
v = flow(n)
v = flow(x,y,z)
[x,y,z,v] = flow(...)
```

**Description** `flow`, a function of three variables, generates fluid-flow data that is useful for demonstrating `slice`, `interp3`, and other functions that visualize scalar volume data.

`v = flow` produces a 50-by-25-by-25 array.

`v = flow(n)` produces a n-by-2n-by-n array.

`v = flow(x,y,z)` evaluates the speed profile at the points `x`, `y`, and `z`.

`[x,y,z,v] = flow(...)` returns the coordinates as well as the volume data.

**See Also** `slice` | `interp3`

**How To**

- “Slicing Fluid Flow Data”

**Purpose**

Find minimum of single-variable function on fixed interval

**Syntax**

```
x = fminbnd(fun,x1,x2)
x = fminbnd(fun,x1,x2,options)
[x,fval] = fminbnd(...)
[x,fval,exitflag] = fminbnd(...)
[x,fval,exitflag,output] = fminbnd(...)
```

**Description**

fminbnd finds the minimum of a function of one variable within a fixed interval.

`x = fminbnd(fun,x1,x2)` returns a value `x` that is a local minimizer of the function that is described in `fun` in the interval  $x_1 < x < x_2$ . `fun` is a `function_handle`.

“Parameterizing Functions” in the MATLAB Mathematics documentation, explains how to pass additional parameters to your objective function `fun`.

`x = fminbnd(fun,x1,x2,options)` minimizes with the optimization parameters specified in the structure `options`. You can define these parameters using the `optimset` function. `fminbnd` uses these `options` structure fields:

|                          |                                                                                                                                                                                                                                                                              |
|--------------------------|------------------------------------------------------------------------------------------------------------------------------------------------------------------------------------------------------------------------------------------------------------------------------|
| <code>Display</code>     | Level of display. 'off' displays no output; 'iter' displays output at each iteration; 'final' displays just the final output; 'notify' (default) displays output only if the function does not converge. See “Iterative Display” in MATLAB Mathematics for more information. |
| <code>FunValCheck</code> | Check whether objective function values are valid. 'on' displays an error when the objective function returns a value that is complex or NaN. 'off' displays no error.                                                                                                       |
| <code>MaxFunEvals</code> | Maximum number of function evaluations allowed.                                                                                                                                                                                                                              |
| <code>MaxIter</code>     | Maximum number of iterations allowed.                                                                                                                                                                                                                                        |

# fminbnd

---

|           |                                                                                                                                                                                                                                                                                                                                                                                                                                                                                                                              |
|-----------|------------------------------------------------------------------------------------------------------------------------------------------------------------------------------------------------------------------------------------------------------------------------------------------------------------------------------------------------------------------------------------------------------------------------------------------------------------------------------------------------------------------------------|
| OutputFcn | User-defined function that is called at each iteration. See “Output Functions” in MATLAB Mathematics for more information.                                                                                                                                                                                                                                                                                                                                                                                                   |
| PlotFcns  | Plots various measures of progress while the algorithm executes, select from predefined plots or write your own. Pass a function handle or a cell array of function handles. The default is none ( <code>[]</code> ). <ul style="list-style-type: none"><li>• <code>@optimplotx</code> plots the current point</li><li>• <code>@optimplotfval</code> plots the function value</li><li>• <code>@optimplotfunccount</code> plots the function count</li></ul> See “Plot Functions” in MATLAB Mathematics for more information. |
| TolX      | Termination tolerance on $x$ .                                                                                                                                                                                                                                                                                                                                                                                                                                                                                               |

`[x,fval] = fminbnd(...)` returns the value of the objective function computed in `fun` at  $x$ .

`[x,fval,exitflag] = fminbnd(...)` returns a value `exitflag` that describes the exit condition of `fminbnd`:

|    |                                                                                       |
|----|---------------------------------------------------------------------------------------|
| 1  | <code>fminbnd</code> converged to a solution $x$ based on <code>options.TolX</code> . |
| 0  | Maximum number of function evaluations or iterations was reached.                     |
| -1 | Algorithm was terminated by the output function.                                      |
| -2 | Bounds are inconsistent ( $x_1 > x_2$ ).                                              |

`[x,fval,exitflag,output] = fminbnd(...)` returns a structure `output` that contains information about the optimization in the following fields:

|            |                                |
|------------|--------------------------------|
| algorithm  | Algorithm used                 |
| funcCount  | Number of function evaluations |
| iterations | Number of iterations           |
| message    | Exit message                   |

## Arguments

`fun` is the function to be minimized. `fun` accepts a scalar `x` and returns a scalar `f`, the objective function evaluated at `x`. The function `fun` can be specified as a function handle for a function file

```
x = fminbnd(@myfun,x1,x2);
```

where `myfun.m` is a function file such as

```
function f = myfun(x)
f = ... % Compute function value at x.
```

or as a function handle for an anonymous function:

```
x = fminbnd(@(x) sin(x*x),x1,x2);
```

Other arguments are described in the syntax descriptions above.

## Examples

`x = fminbnd(@cos,3,4)` computes  $\pi$  to a few decimal places and gives a message on termination.

```
[x,fval,exitflag] = ...
 fminbnd(@cos,3,4,optimset('TolX',1e-12,'Display','off'))
```

computes  $\pi$  to about 12 decimal places, suppresses output, returns the function value at `x`, and returns an `exitflag` of 1.

The argument `fun` can also be a function handle for an anonymous function. For example, to find the minimum of the function  $f(x) = x^3 - 2x - 5$  on the interval  $(0,2)$ , create an anonymous function `f`

```
f = @(x)x.^3-2*x-5;
```

# fminbnd

---

Then invoke `fminbnd` with

```
x = fminbnd(f, 0, 2)
```

The result is

```
x =
 0.8165
```

The value of the function at the minimum is

```
y = f(x)

y =
 -6.0887
```

If `fun` is parameterized, you can use anonymous functions to capture the problem-dependent parameters. For example, suppose you want to minimize the objective function `myfun` defined by the following function file:

```
function f = myfun(x,a)
f = (x - a)^2;
```

Note that `myfun` has an extra parameter `a`, so you cannot pass it directly to `fminbnd`. To optimize for a specific value of `a`, such as `a = 1.5`.

**1** Assign the value to `a`.

```
a = 1.5; % define parameter first
```

**2** Call `fminbnd` with a one-argument anonymous function that captures that value of `a` and calls `myfun` with two arguments:

```
x = fminbnd(@(x) myfun(x,a),0,1)
```

## Algorithms

`fminbnd` is a function file. Its algorithm is based on golden section search and parabolic interpolation. Unless the left endpoint  $x_1$  is very



close to the right endpoint  $x_2$ , `fminbnd` never evaluates `fun` at the endpoints, so `fun` need only be defined for  $x$  in the interval  $x_1 < x < x_2$ .

If the minimum actually occurs at  $x_1$  or  $x_2$ , `fminbnd` returns a point  $x$  in the interior of the interval  $(x_1, x_2)$  that is close to the minimizer. In this case, the distance of  $x$  from the minimizer is no more than  $2 * (\text{To1X} + 3 * \text{abs}(x) * \text{sqrt}(\text{eps}))$ . See [1] or [2] for details about the algorithm.

## Limitations

The function to be minimized must be continuous. `fminbnd` may only give local solutions.

`fminbnd` often exhibits slow convergence when the solution is on a boundary of the interval.

`fminbnd` only handles real variables.

## References

[1] Forsythe, G. E., M. A. Malcolm, and C. B. Moler, *Computer Methods for Mathematical Computations*, Prentice-Hall, 1976.

[2] Brent, Richard. P., *Algorithms for Minimization without Derivatives*, Prentice-Hall, Englewood Cliffs, New Jersey, 1973

## See Also

`fminsearch` | `fzero` | `optimset` | `function_handle`

## How To

- anonymous function

# fminsearch

---

**Purpose** Find minimum of unconstrained multivariable function using derivative-free method

**Syntax**

```
x = fminsearch(fun,x0)
x = fminsearch(fun,x0,options)
[x,fval] = fminsearch(...)
[x,fval,exitflag] = fminsearch(...)
[x,fval,exitflag,output] = fminsearch(...)
```

**Description** `fminsearch` finds the minimum of a scalar function of several variables, starting at an initial estimate. This is generally referred to as *unconstrained nonlinear optimization*.

`x = fminsearch(fun,x0)` starts at the point `x0` and returns a value `x` that is a local minimizer of the function described in `fun`. `x0` can be a scalar, vector, or matrix. `fun` is a `function_handle`.

“Parameterizing Functions” in the MATLAB Mathematics documentation explains how to pass additional parameters to your objective function `fun`. See also “Example 2” on page 1-2251 and “Example 3” on page 1-2251 below.

`x = fminsearch(fun,x0,options)` minimizes with the optimization parameters specified in the structure `options`. You can define these parameters using the `optimset` function. `fminsearch` uses these `options` structure fields:

|                          |                                                                                                                                                                                                                                                                              |
|--------------------------|------------------------------------------------------------------------------------------------------------------------------------------------------------------------------------------------------------------------------------------------------------------------------|
| <code>Display</code>     | Level of display. 'off' displays no output; 'iter' displays output at each iteration; 'final' displays just the final output; 'notify' (default) displays output only if the function does not converge. See “Iterative Display” in MATLAB Mathematics for more information. |
| <code>FunValCheck</code> | Check whether objective function values are valid. 'on' displays an error when the objective function returns a value that is complex, Inf or NaN. 'off' (the default) displays no error.                                                                                    |

|             |                                                                                                                                                                                                                                                                                                                                                                                                                                                                         |
|-------------|-------------------------------------------------------------------------------------------------------------------------------------------------------------------------------------------------------------------------------------------------------------------------------------------------------------------------------------------------------------------------------------------------------------------------------------------------------------------------|
| MaxFunEvals | Maximum number of function evaluations allowed                                                                                                                                                                                                                                                                                                                                                                                                                          |
| MaxIter     | Maximum number of iterations allowed                                                                                                                                                                                                                                                                                                                                                                                                                                    |
| OutputFcn   | User-defined function that is called at each iteration. See “Output Functions” in MATLAB Mathematics for more information.                                                                                                                                                                                                                                                                                                                                              |
| PlotFcns    | Plots various measures of progress while the algorithm executes, select from predefined plots or write your own. Pass a function handle or a cell array of function handles. The default is none ( []). <ul style="list-style-type: none"><li>• @optimplotx plots the current point</li><li>• @optimplotfval plots the function value</li><li>• @optimplotfunccount plots the function count</li></ul> See “Plot Functions” in MATLAB Mathematics for more information. |
| TolFun      | Termination tolerance on the function value                                                                                                                                                                                                                                                                                                                                                                                                                             |
| TolX        | Termination tolerance on x                                                                                                                                                                                                                                                                                                                                                                                                                                              |

`[x,fval] = fminsearch(...)` returns in `fval` the value of the objective function `fun` at the solution `x`.

`[x,fval,exitflag] = fminsearch(...)` returns a value `exitflag` that describes the exit condition of `fminsearch`:

|    |                                                                   |
|----|-------------------------------------------------------------------|
| 1  | <code>fminsearch</code> converged to a solution <code>x</code> .  |
| 0  | Maximum number of function evaluations or iterations was reached. |
| -1 | Algorithm was terminated by the output function.                  |

`[x,fval,exitflag,output] = fminsearch(...)` returns a structure `output` that contains information about the optimization in the following fields:

# fminsearch

---

|            |                                     |
|------------|-------------------------------------|
| algorithm  | 'Nelder-Mead simplex direct search' |
| funcCount  | Number of function evaluations      |
| iterations | Number of iterations                |
| message    | Exit message                        |

## Arguments

fun is the function to be minimized. It accepts an input x and returns a scalar f, the objective function evaluated at x. The function fun can be specified as a function handle for a function file

```
x = fminsearch(@myfun, x0)
```

where myfun is a function file such as

```
function f = myfun(x)
f = ... % Compute function value at x
```

or as a function handle for an anonymous function, such as

```
x = fminsearch(@(x)sin(x^2), x0);
```

Other arguments are described in the syntax descriptions above.

## Examples

### Example 1

The Rosenbrock banana function is a classic test example for multidimensional minimization:

$$f(x) = 100(x_2 - x_1^2)^2 + (1 - x_1)^2.$$

The minimum is at (1, 1) and has the value 0. The traditional starting point is (-1.2, 1). The anonymous function shown here defines the function and returns a function handle called banana:

```
banana = @(x)100*(x(2)-x(1)^2)^2+(1-x(1))^2;
```

Pass the function handle to fminsearch:

```
[x,fval] = fminsearch(banana,[-1.2, 1])
```

This produces

```
x =
```

```
 1.0000 1.0000
```

```
fval =
```

```
 8.1777e-010
```

This indicates that the minimizer was found to at least four decimal places with a value near zero.

## Example 2

If `fun` is parameterized, you can use anonymous functions to capture the problem-dependent parameters. For example, suppose you want to minimize the objective function `myfun` defined by the following function file:

```
function f = myfun(x,a)
f = x(1)^2 + a*x(2)^2;
```

Note that `myfun` has an extra parameter `a`, so you cannot pass it directly to `fminsearch`. To optimize for a specific value of `a`, such as `a = 1.5`.

**1** Assign the value to `a`.

```
a = 1.5; % define parameter first
```

**2** Call `fminsearch` with a one-argument anonymous function that captures that value of `a` and calls `myfun` with two arguments:

```
x = fminsearch(@(x) myfun(x,a),[0,1])
```

## Example 3

You can modify the first example by adding a parameter `a` to the second term of the `banana` function:

$$f(x) = 100(x_2 - x_1^2)^2 + (a - x_1)^2.$$

This changes the location of the minimum to the point  $[a, a^2]$ . To minimize this function for a specific value of  $a$ , for example  $a = \sqrt{2}$ , create a one-argument anonymous function that captures the value of  $a$ .

```
a = sqrt(2);
banana = @(x) 100*(x(2)-x(1)^2)^2+(a-x(1))^2;
```

Then the statement

```
[x,fval] = fminsearch(banana, [-1.2, 1], ...
 optimset('TolX',1e-8));
```

seeks the minimum  $[\sqrt{2}, 2]$  to an accuracy higher than the default on  $x$ .

## Algorithms

`fminsearch` uses the simplex search method of Lagarias et al. [1]. This is a direct search method that does not use numerical or analytic gradients.

If  $n$  is the length of  $x$ , a simplex in  $n$ -dimensional space is characterized by the  $n+1$  distinct vectors that are its vertices. In two-space, a simplex is a triangle; in three-space, it is a pyramid. At each step of the search, a new point in or near the current simplex is generated. The function value at the new point is compared with the function's values at the vertices of the simplex and, usually, one of the vertices is replaced by the new point, giving a new simplex. This step is repeated until the diameter of the simplex is less than the specified tolerance.

For more information, see “`fminsearch` Algorithm”.

## Limitations

`fminsearch` can often handle discontinuity, particularly if it does not occur near the solution. `fminsearch` may only give local solutions.

`fminsearch` only minimizes over the real numbers, that is,  $x$  must only consist of real numbers and  $f(x)$  must only return real numbers. When  $x$  has complex variables, they must be split into real and imaginary parts.

## References

[1] Lagarias, J.C., J. A. Reeds, M. H. Wright, and P. E. Wright, "Convergence Properties of the Nelder-Mead Simplex Method in Low Dimensions," *SIAM Journal of Optimization*, Vol. 9 Number 1, pp. 112-147, 1998.

## See Also

fminbnd | optimset | function\_handle

## How To

- anonymous function

# fopen

---

**Purpose** Open file, or obtain information about open files

**Syntax**

```
fileID = fopen(filename)
fileID = fopen(filename,permission)
fileID = fopen(filename,permission,machinefmt,encodingIn)
[fileID,errmsg] = fopen(___)
```

```
fIDs = fopen('all')
```

```
filename = fopen(fileID)
[filename,permission,machinefmt,encodingOut]
= fopen(fileID)
```

**Description** `fileID = fopen(filename)` opens the file, `filename`, for binary read access, and returns an integer file identifier equal to or greater than 3. MATLAB reserves file identifiers 0, 1, and 2 for standard input, standard output (the screen), and standard error, respectively.

If `fopen` cannot open the file, then `fileID` is -1.

`fileID = fopen(filename,permission)` opens the file with the type of access specified by `permission`.

`fileID = fopen(filename,permission,machinefmt,encodingIn)` additionally specifies the order for reading or writing bytes or bits in the file using the `machinefmt` argument. The optional `encodingIn` argument specifies the character encoding scheme associated with the file.

`[fileID,errmsg] = fopen( ___ )` additionally returns a system-dependent error message if `fopen` fails to open the file. Otherwise, `errmsg` is an empty string. You can use this syntax with any of the input arguments of the previous syntaxes.



`fIDs = fopen('all')` returns a row vector containing the file identifiers of all open files. The identifiers reserved for standard input, output, and error are not included. The number of elements in the vector is equal to the number of open files.

`filename = fopen(fileID)` returns the file name that a previous call to `fopen` used when it opened the file specified by `fileID`. The output `filename` is resolved to the full path. The `fopen` function does not read information from the file to determine the output value.

`[filename,permission,machinefmt,encodingOut] = fopen(fileID)` additionally returns the permission, machine format, and encoding that a previous call to `fopen` used when it opened the specified file. If the file was opened in binary mode, `permission` includes the letter 'b'. The `encodingOut` output is a standard encoding scheme name. `fopen` does not read information from the file to determine these output values. An invalid `fileID` returns empty strings for all output arguments.

## Input Arguments

### **filename - Name of file to open**

string

Name of the file to open, including the file extension, specified as a string. If the file is not in the current folder, `filename` must include a full or a relative path.

On UNIX systems, if `filename` begins with `'~/ '` or `'~username/ '`, the `fopen` function expands the path to the current or specified user's home directory, respectively.

- If you open a file with read access and the file is not in the current folder, then `fopen` searches along the MATLAB search path.
- If you open a file with write or append access and the file is not in the current folder, then `fopen` creates a file in the current directory.

**Example:** `'myFile.txt'`

## Data Types

char

### permission - File access type

'r' (default) | 'w' | 'a' | 'r+' | 'w+' | 'a+' | 'A' | 'W' | ...

File access type, specified as a string. You can open a file in binary mode or in text mode. On UNIX systems, both translation modes have the same effect. To open a file in binary mode, specify one of the following strings.

|      |                                                                                          |
|------|------------------------------------------------------------------------------------------|
| 'r'  | Open file for reading.                                                                   |
| 'w'  | Open or create new file for writing. Discard existing contents, if any.                  |
| 'a'  | Open or create new file for writing. Append data to the end of the file.                 |
| 'r+' | Open file for reading and writing.                                                       |
| 'w+' | Open or create new file for reading and writing. Discard existing contents, if any.      |
| 'a+' | Open or create new file for reading and writing. Append data to the end of the file.     |
| 'A'  | Append without automatic flushing of the current output buffer. (Used with tape drives.) |
| 'W'  | Write without automatic flushing of the current output buffer. (Used with tape drives.)  |

To open files in text mode, attach the letter 't' to the permission argument, such as 'rt' or 'wt+'.

On Windows systems, in text mode:

- Read operations that encounter a carriage return followed by a newline character ('\r\n') remove the carriage return from the input.

- Write operations insert a carriage return before any newline character in the output.

Open or create a new file in text mode if you want to write to it in MATLAB and then open it in Microsoft Notepad, or any text editor that does not recognize '\n' as a newline sequence. When writing to the file, end each line with '\r\n'. For an example, see `fprintf`. Otherwise, open files in binary mode for better performance.

To read and write to the same file:

- Open the file with a value for permission that includes a plus sign, '+'.  
 For example, use `'r+'`.
- Call `fseek` or `frewind` between read and write operations. For example, do not call `fread` followed by `fwrite`, or `fwrite` followed by `fread`, unless you call `fseek` or `frewind` between them.

### **machinefmt - Order for reading or writing bytes or bits**

'n' (default) | 'b' | 'l' | 's' | 'a' | ...

Order for reading or writing bytes or bits in the file, specified as one of the following strings.

|                      |                                               |
|----------------------|-----------------------------------------------|
| 'n' or 'native'      | Your system byte ordering (default)           |
| 'b' or 'ieee-be'     | Big-endian ordering                           |
| 'l' or 'ieee-le'     | Little-endian ordering                        |
| 's' or 'ieee-be.164' | Big-endian ordering, 64-bit long data type    |
| 'a' or 'ieee-le.164' | Little-endian ordering, 64-bit long data type |

By default, all currently supported platforms use little-endian ordering for new files. Existing binary files can use either big-endian or little-endian ordering.

### **encodingIn - Character encoding**

'UTF-8' | 'ISO-8859-1' | 'windows-1251' | 'windows-1252' | ...

Character encoding to use for subsequent read and write operations, including `fscanf`, `fprintf`, `fgetl`, `fgets`, `fread`, and `fwrite`, specified as one of the following strings.

|             |               |                |
|-------------|---------------|----------------|
| 'Big5'      | 'ISO-8859-1'  | 'windows-932'  |
| 'EUC-JP'    | 'ISO-8859-2'  | 'windows-936'  |
| 'GBK'       | 'ISO-8859-3'  | 'windows-949'  |
| 'KSC_5601'  | 'ISO-8859-4'  | 'windows-950'  |
| 'Macintosh' | 'ISO-8859-9'  | 'windows-1250' |
| 'Shift_JIS' | 'ISO-8859-13' | 'windows-1251' |
| 'US-ASCII'  | 'ISO-8859-15' | 'windows-1252' |
| 'UTF-8'     |               | 'windows-1253' |
|             |               | 'windows-1254' |
|             |               | 'windows-1257' |

The default encoding is system-dependent.

If you specify a value for encoding that is not in the list of supported values, MATLAB issues a warning. Specifying other encoding names sometimes (but not always) produces correct results.

## Data Types

`char`

## **fileID** - File identifier of an open file

`integer`

File identifier of an open file, specified as an integer.

## Data Types

`double`

## Examples

### **Open File and Pass Identifier to File I/O Function**

Open a file and pass the file identifier to the `fgetl` function to read data.

Open the file, `airfoil.m`, and obtain the file identifier.

```
fileID = fopen('airfoil.m');
```

Pass the `fileID` to the `fgetl` function to read one line from the file. Then, close the file.

```
tline = fgetl(fileID);
fclose(fileID)
```

### **Request Name of File to Open**

Create a prompt to request the name of a file to open. If `fopen` cannot open the file, display the relevant error message.

```
fileID = -1;
errmsg = '';
while fileID < 0
 disp(errmsg);
 filename = input('Open file: ', 's');
 [fileID,errmsg] = fopen(filename);
end
```

### **Open File for Writing and Specify Access Type, Writing Order, Character Encoding**

Open a file to write to a file using the Shift-JIS character encoding.

```
fileID = fopen('japanese_out.txt', 'w', 'n', 'Shift_JIS');
```

The `'w'` input specifies write access, the `'n'` input specifies native byte ordering, and `'Shift_JIS'` specifies the character encoding scheme.

### **Get Information About Open Files**

Suppose you previously opened a file using `fopen`.

```
fileID = fopen('airfoil.m');
```

Get the file identifiers of all open files.

# fopen

---

```
fIDs = fopen('all')
```

```
fIDs =
```

```
3
```

Get the file name and character encoding for the open file. Use ~ in place of output arguments you want to omit.

```
[filename,~,~,encoding] = fopen(3)
```

```
filename =
```

```
matlabroot\toolbox\matlab\demos\airfoil.m
```

```
encoding =
```

```
windows-1252
```

The output shown here is representative. Your results might differ.

## Tips

- In most cases, it is not necessary to open a file in text mode. MATLAB import functions, all UNIX applications, and Microsoft Word and WordPad recognize '\n' as a newline indicator.

## See Also

```
fclose | ferror | fseek | ftell | feof | fscanf | fprintf | fread
| fwrite | frewind
```

**Purpose** Connect serial port object to device

**Syntax** fopen(obj)

**Description** fopen(obj) connects the serial port object, obj to the device.

**Tips** Before you can perform a read or write operation, obj must be connected to the device with the fopen function. When obj is connected to the device:

- Data remaining in the input buffer or the output buffer is flushed.
- The Status property is set to open.
- The BytesAvailable, ValuesReceived, ValuesSent, and BytesToOutput properties are set to 0.

An error is returned if you attempt to perform a read or write operation while obj is not connected to the device. You can connect only one serial port object to a given device.

Some properties are read-only while the serial port object is open (connected), and must be configured before using fopen. Examples include InputBufferSize and OutputBufferSize. Refer to the property reference pages to determine which properties have this constraint.

The values for some properties are verified only after obj is connected to the device. If any of these properties are incorrectly configured, then an error is returned when fopen is issued and obj is not connected to the device. Properties of this type include BaudRate, and are associated with device settings.

**Examples** This example creates the serial port object s, connects s to the device using fopen, writes and reads text data, and then disconnects s from the device. This example works on a Windows platform.

```
s = serial('COM1');
fopen(s)
fprintf(s, '*IDN?')
```

# fopen (serial)

---

```
idn = fscanf(s);
fclose(s)
```

## See Also

[fclose](#) | [BytesAvailable](#) | [BytesToOutput](#) | [Status](#) | [ValuesReceived](#) | [ValuesSent](#)



---

|                    |                                                                                                                                                                                                                                                                                                                                                                                                                                                                                                                                                                                                                                                                                                                                                                                                                                                                                                                                                                                                                                 |
|--------------------|---------------------------------------------------------------------------------------------------------------------------------------------------------------------------------------------------------------------------------------------------------------------------------------------------------------------------------------------------------------------------------------------------------------------------------------------------------------------------------------------------------------------------------------------------------------------------------------------------------------------------------------------------------------------------------------------------------------------------------------------------------------------------------------------------------------------------------------------------------------------------------------------------------------------------------------------------------------------------------------------------------------------------------|
| <b>Purpose</b>     | Execute statements specified number of times                                                                                                                                                                                                                                                                                                                                                                                                                                                                                                                                                                                                                                                                                                                                                                                                                                                                                                                                                                                    |
| <b>Syntax</b>      | <pre>for <i>index</i> = <i>values</i>     <i>program statements</i>     : end</pre>                                                                                                                                                                                                                                                                                                                                                                                                                                                                                                                                                                                                                                                                                                                                                                                                                                                                                                                                             |
| <b>Description</b> | <p>for <i>index=values</i>, <i>program statements</i>, end repeatedly executes one or more MATLAB statements in a loop. <i>values</i> has one of the following forms:</p> <p><i>initval:endval</i> increments the <i>index</i> variable from <i>initval</i> to <i>endval</i> by 1, and repeats execution of <i>program statements</i> until <i>index</i> is greater than <i>endval</i>.</p> <p><i>initval:step:endval</i> increments <i>index</i> by the value <i>step</i> on each iteration, or decrements when <i>step</i> is negative.</p> <p><i>valArray</i> creates a column vector <i>index</i> from subsequent columns of array <i>valArray</i> on each iteration. For example, on the first iteration, <i>index</i> = <i>valArray</i>(:,1). The loop executes for a maximum of <i>n</i> times, where <i>n</i> is the number of columns of <i>valArray</i>, given by <code>numel(<i>valArray</i>, 1, :)</code>. The input <i>valArray</i> can be of any MATLAB data type, including a string, cell array, or struct.</p> |
| <b>Tips</b>        | <ul style="list-style-type: none"><li>• To force an immediate exit of the loop, use a <code>break</code> or <code>return</code> statement. To skip the rest of the instructions in the loop, increment the loop counter, and begin the next iteration, use a <code>continue</code> statement.</li><li>• Avoid assigning a value to the <i>index</i> variable within the body of a loop. The <code>for</code> statement overrides any changes made to the <i>index</i> within the loop.</li></ul>                                                                                                                                                                                                                                                                                                                                                                                                                                                                                                                                |

# for

---

- To iterate over the values of a single column vector, first transpose it to create a row vector.

## Examples

Create a Hilbert matrix using nested for loops:

```
k = 10;
hilbert = zeros(k,k); % Preallocate matrix

for m = 1:k
 for n = 1:k
 hilbert(m,n) = 1/(m+n -1);
 end
end
```

---

Step by increments of -0.1, and display the step values:

```
for s = 1.0: -0.1: 0.0
 disp(s)
end
```

---

Execute statements for a defined set of index values:

```
for s = [1,5,8,17]
 disp(s)
end
```

---

Successively set e to unit vectors:

```
for e = eye(5)
 disp('Current value of e:')
 disp(e)
end
```

## See Also

end | break | continue | parfor | return | switch | colon | if

**Purpose** Set display format for output

**Syntax** format  
format Style

**Description** format sets the display of floating-point numeric values to the default display format, which is the short fixed decimal format. This format displays 5-digit scaled, fixed-point values.

The format function affects only how numbers display in the Command Window, not how MATLAB computes or saves them.

format Style changes the display format to the specified Style.

## Input Arguments

### Style - Output display format

short (default) | long | shortE | longE | ...

Output display format, specified as one of the strings listed in the tables that follow.

Use these styles to switch between different output display formats for floating-point variables. Styles are case insensitive. You also can insert a space between short or long and the presentation type, for instance, format short E.

| Style              | Result                                                                                                                                                                                                                                 | Example           |
|--------------------|----------------------------------------------------------------------------------------------------------------------------------------------------------------------------------------------------------------------------------------|-------------------|
| short<br>(default) | Short fixed decimal format, with 4 digits after the decimal point.<br><br>If you are displaying a matrix with a wide range of values, consider using shortG. See “Display Large Data Range in short and shortg Formats” on page 1-2270 | 3.1416            |
| long               | Long fixed decimal format, with 15 digits after the decimal point for double values, and 7 digits                                                                                                                                      | 3.141592653589793 |

# format

| Style    | Result                                                                                                                                                                                                                                                                   | Example               |
|----------|--------------------------------------------------------------------------------------------------------------------------------------------------------------------------------------------------------------------------------------------------------------------------|-----------------------|
|          | after the decimal point for <b>single</b> values.                                                                                                                                                                                                                        |                       |
| shortE   | Short scientific notation, with 4 digits after the decimal point.<br><br>Integer-valued floating-point numbers with a maximum of 9 digits do not display in scientific notation.                                                                                         | 3.1416e+00            |
| longE    | Long scientific notation, with 15 digits after the decimal point for <b>double</b> values, and 7 digits after the decimal point for <b>single</b> values.<br><br>Integer-valued floating-point numbers with a maximum of 9 digits do not display in scientific notation. | 3.141592653589793e+00 |
| shortG   | The more compact of short fixed decimal or scientific notation, with 5 digits.                                                                                                                                                                                           | 3.1416                |
| longG    | The more compact of long fixed decimal or scientific notation, with 15 digits for <b>double</b> values, and 7 digits for <b>single</b> values.                                                                                                                           | 3.14159265358979      |
| shortEng | Short engineering notation, with 4 digits after the decimal point, and an exponent that is a multiple of 3.                                                                                                                                                              | 3.1416e+000           |
| longEng  | Long engineering notation, with 15 significant digits, and an exponent that is a multiple of 3.                                                                                                                                                                          | 3.14159265358979e+000 |

Use these format styles to switch between different output display formats for all numeric variables.

| Style | Result                                                                                                         | Example          |
|-------|----------------------------------------------------------------------------------------------------------------|------------------|
| +     | Positive/Negative format, with +, -, and blank characters displayed for positive, negative, and zero elements. | +                |
| bank  | Currency format, with 2 digits after the decimal point.                                                        | 3.14             |
| hex   | Hexadecimal representation of a binary double-precision number.                                                | 400921fb54442d18 |
| rat   | Ratio of small integers.                                                                                       | 355/113          |

Use these format styles to affect the spacing in the display of all variables.

| DispType | Result                                                                                    | Example                                      |
|----------|-------------------------------------------------------------------------------------------|----------------------------------------------|
| compact  | Suppresses excess line feeds to show more output in a single screen. Contrast with loose. | theta =<br>pi/2<br>theta =<br>1.5708         |
| loose    | Adds linefeeds to make output more readable. Contrast with compact.                       | theta =<br>pi/2<br><br>theta =<br><br>1.5708 |

## Examples

### Change and View Current Format

Set the display format to long fixed decimal.

```
format long
```

# format

---

View the result for the value of pi.

```
pi
ans =
 3.141592653589793
```

View the current format.

```
get(0, 'format')
ans =
 long
```

## Display Values in Default and Hexadecimal Format

Set the format to its default, and display the maximum values for integers and real numbers in MATLAB.

```
format
intmax('uint64')
ans =
 18446744073709551615
```

```
realmax
ans =
 1.7977e+308
```

Change the display format to hexadecimal, and then display the same values.

```
format hex
```

```
intmax('uint64')

ans =

 ffffffffffffffffff

realmax

ans =

 7fefffffffffffffff
```

The hexadecimal display corresponds to the internal representation of the value. It is not the same as the hexadecimal notation in the C programming language.

### **View Output in Short and Long Engineering Notation**

View the difference between output displayed in the shortEng and longEng formats.

Set the display format to shortEng.

```
format shortEng
```

Create variable A and increase its value by a multiple of 10 each time through a for loop. Display each value of A.

```
A = 5.123456789;
for k=1:10
 disp(A)
 A = A * 10;
end
```

```
 5.1235e+000
 51.2346e+000
 512.3457e+000
 5.1235e+003
 51.2346e+003
```

# format

---

```
512.3457e+003
 5.1235e+006
51.2346e+006
512.3457e+006
 5.1235e+009
```

The values for A display with 4 digits after the decimal point, and an exponent that is a multiple of 3.

Set the display format to longEng and view the same values of A.

```
format longEng
```

```
A = 5.123456789;
for k=1:10
 disp(A)
 A = A * 10;
end
```

```
5.12345678900000e+000
51.2345678900000e+000
512.345678900000e+000
5.12345678900000e+003
51.2345678900000e+003
512.345678900000e+003
5.12345678900000e+006
51.2345678900000e+006
512.345678900000e+006
5.12345678900000e+009
```

The values for A display with 15 digits, and an exponent that is a multiple of 3.

## **Display Large Data Range in short and shortg Formats**

View the difference between the short and shortg formats when the values in a matrix span a wide range.

Define variable x and display the output in the short format.



```
x = [25 56 255 9876899999];
format short
x

x =
 1.0e+09 *
 0.0000 0.0000 0.0000 9.8769
```

The display indicates each value is multiplied by 1.0e+09.

Set the format to shortg and redisplay x.

```
format shortg
x

x =
 25 56 255 9.8769e+09
```

## Algorithms

MATLAB always displays integer variables to the appropriate number of digits for the class. For example, MATLAB uses 3 digits to display numbers of type `int8` (for example, `-128:127`). Setting `format` to `short` or `long` does not affect the display of integer variables.

If the largest element of a matrix is larger than  $10^3$  or smaller than  $10^{-3}$ , then MATLAB applies a common scale factor for the `short` and `long` formats.

## Tips

- The specified format applies only to the current MATLAB session. To maintain a format across sessions, choose a **Numeric format** or **Numeric display** option in the Command Window Preferences.
- To see which Style is currently in use, type

```
get(0, 'Format')
```

To see if `compact` or `loose` formatting is currently selected, type

```
get(0, 'FormatSpacing')
```

# format

---

## See Also

`disp` | `display` | `isnumeric` | `isfloat` | `isinteger` | `floor` | `sprintf`  
| `fprintf` | `num2str` | `rat` | `spy`

## Concepts

- “Format Output in Command Window”

**Purpose**

Plot function between specified limits

**Syntax**

```
fplot(fun,limits)
fplot(fun,limits,LineStyle)
fplot(fun,limits,tol)
fplot(fun,limits,tol,LineStyle)
fplot(fun,limits,n)
fplot(fun,lims,...)
fplot(axes_handle,...)
[X,Y] = fplot(fun,limits,...)
```

**Description**

fplot plots a function between specified limits. The function must be of the form  $y = f(x)$ , where  $x$  is a vector whose range specifies the limits, and  $y$  is a vector the same size as  $x$  and contains the function's value at the points in  $x$  (see the first example). If the function returns more than one value for a given  $x$ , then  $y$  is a matrix whose columns contain each component of  $f(x)$  (see the second example).

fplot(fun,limits) plots fun between the limits specified by limits. limits is a vector specifying the  $x$ -axis limits ([xmin xmax]), or the  $x$ - and  $y$ -axes limits, ([xmin xmax ymin ymax]).

fun must be

- The name of a function
- A string with variable  $x$  that may be passed to eval, such as 'sin(x)', 'diric(x,10)', or '[sin(x),cos(x)]'
- A function handle

The function  $f(x)$  must return a row vector for each element of vector  $x$ . For example, if  $f(x)$  returns  $[f_1(x), f_2(x), f_3(x)]$  then for input  $[x_1; x_2]$  the function should return the matrix

```
f1(x1) f2(x1) f3(x1)
f1(x2) f2(x2) f3(x2)
```

fplot(fun,limits,LineStyle) plots fun using the line specification LineSpec.

# fplot

---

`fplot(fun,limits,tol)` plots `fun` using the relative error tolerance `tol` (the default is  $2e-3$ , i.e., 0.2 percent accuracy).

`fplot(fun,limits,tol,LineStyle)` plots `fun` using the relative error tolerance `tol` and a line specification that determines line type, marker symbol, and color. See `LineStyle` for more information.

`fplot(fun,limits,n)` with  $n \geq 1$  plots the function with a minimum of  $n+1$  points. The default  $n$  is 1. The maximum step size is restricted to be  $(1/n) * (x_{\max} - x_{\min})$ .

`fplot(fun,lims,...)` accepts combinations of the optional arguments `tol`, `n`, and `LineStyle`, in any order.

`fplot(axes_handle,...)` plots into the axes with handle `axes_handle` instead of the current axes (`gca`).

`[X,Y] = fplot(fun,limits,...)` returns the abscissas and ordinates for `fun` in `X` and `Y`. No plot is drawn on the screen; however, you can plot the function using `plot(X,Y)`.

## Tips

`fplot` uses adaptive step control to produce a representative graph, concentrating its evaluation in regions where the function's rate of change is the greatest.

## Examples

### **MATLAB® Function Handle**

Plot the hyperbolic tangent function from -2 to 2 using the MATLAB® function `tanh`.

```
fh = @tanh;
fplot(fh,[-2,2])
```

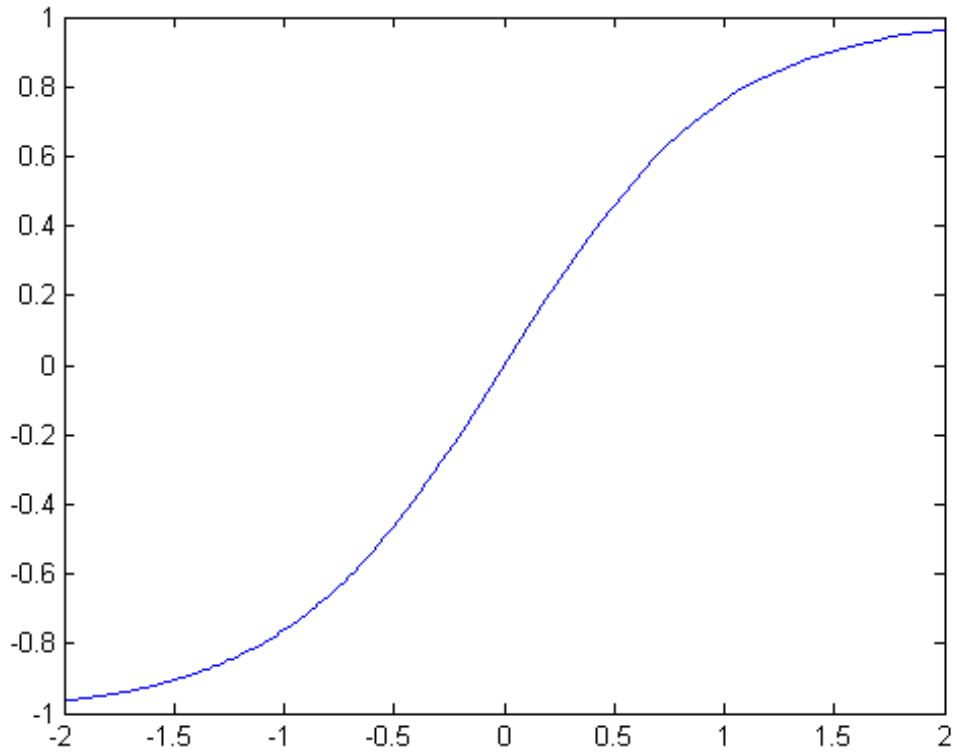

### Function Handle Created From Anonymous Function

Create a function handle from an anonymous function. Plot the function from 0.01 to 0.1.

```
sn = @(x) sin(1./x);
fplot(sn,[0.01,0.1])
```

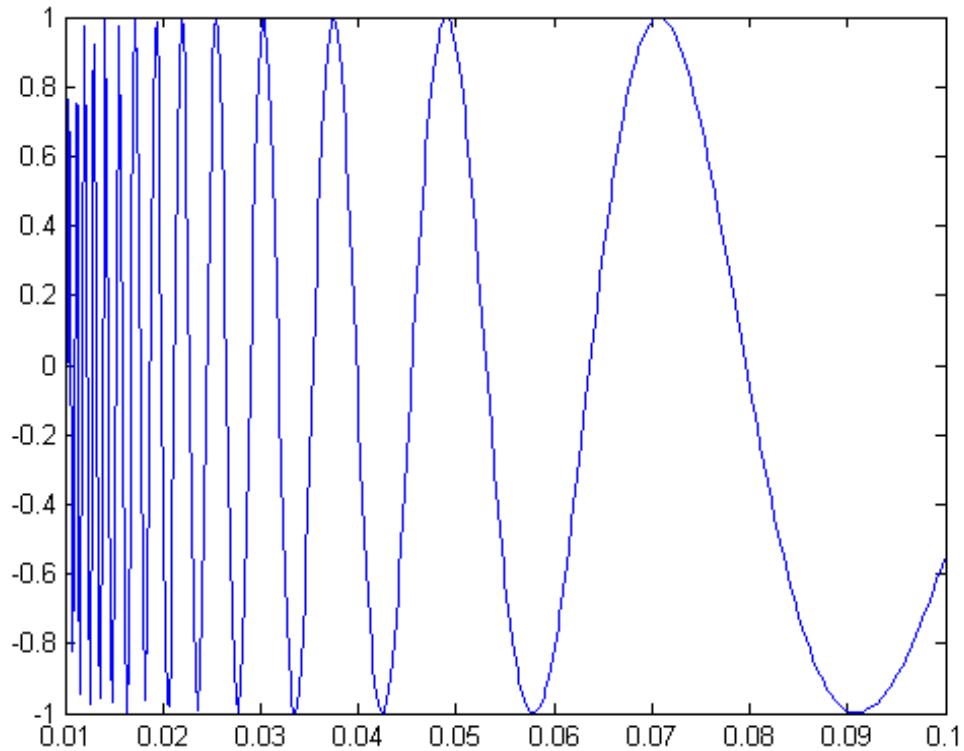

## Function Handle Created From Custom Function File

Create a file named `myfun.m` that contains the following code.

```
function Y = myfun(x)
Y(:,1) = 200*sin(x(:))./x(:);
Y(:,2) = x(:).^2;
```

Then, create a function handle pointing to `myfun`.

```
fh = @myfun;
```

Plot the function from -20 to 20.

```
fplot(fh, [-20 20])
```

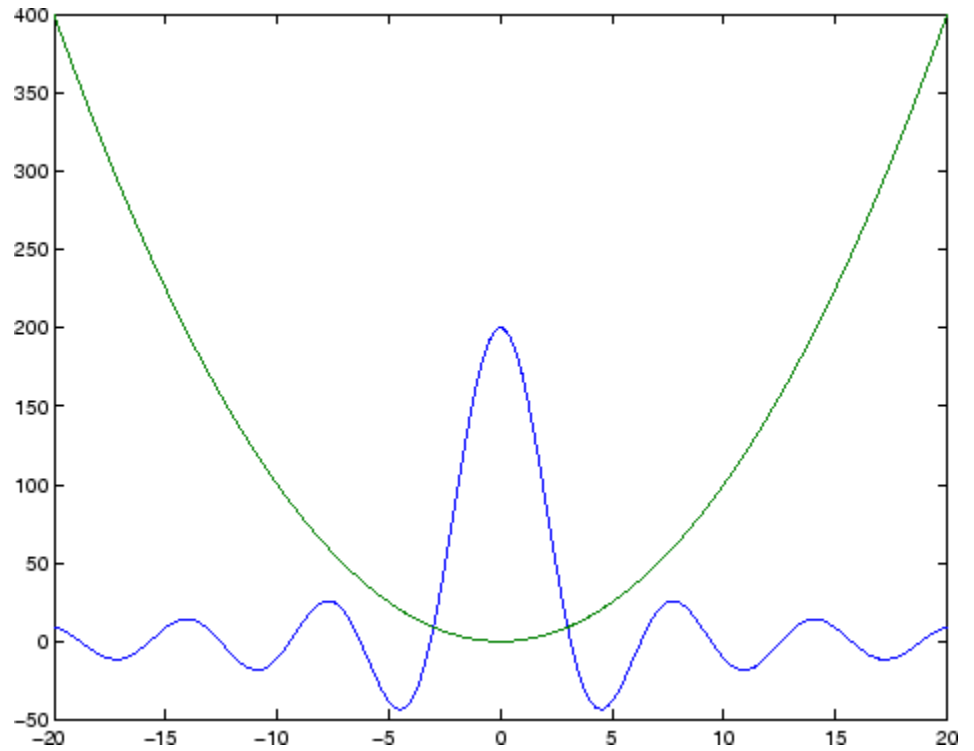

### See Also

[eval](#) | [ezplot](#) | [feval](#) | [LineStyle](#) | [plot](#)

### How To

- [Anonymous Functions](#)

# fprintf

---

## Purpose

Write data to text file

## Syntax

```
fprintf(fileID,formatSpec,A1,...,An)
fprintf(formatSpec,A1,...,An)
```

```
nbytes = fprintf(___)
```

## Description

`fprintf(fileID,formatSpec,A1,...,An)` applies the `formatSpec` to all elements of arrays `A1,...,An` in column order, and writes the data to a text file. `fprintf` uses the encoding scheme specified in the call to `fopen`.

`fprintf(formatSpec,A1,...,An)` formats data and displays the results on the screen.

`nbytes = fprintf( ___ )` returns the number of bytes that `fprintf` writes, using any of the input arguments in the preceding syntaxes.

## Input Arguments

### **fileID - File identifier**

1 (default) | 2 | scalar

File identifier, specified as one of the following:

- A file identifier obtained from `fopen`.
- 1 for standard output (the screen).
- 2 for standard error.

### **Data Types**

double

### **formatSpec - Format of the output fields**

string

Format of the output fields, specified as a string.



The string can include a percent sign followed by a conversion character. The following table lists the available conversion characters and subtypes.

| Value Type            | Conversion               | Details                                                                                             |
|-----------------------|--------------------------|-----------------------------------------------------------------------------------------------------|
| Integer, signed       | %d or %i                 | Base 10                                                                                             |
| Integer, unsigned     | %u                       | Base 10                                                                                             |
|                       | %o                       | Base 8 (octal)                                                                                      |
|                       | %x                       | Base 16 (hexadecimal), lowercase letters a–f                                                        |
|                       | %X                       | Same as %x, uppercase letters A–F                                                                   |
| Floating-point number | %f                       | Fixed-point notation                                                                                |
|                       | %e                       | Exponential notation, such as 3.141593e+00                                                          |
|                       | %E                       | Same as %e, but uppercase, such as 3.141593E+00                                                     |
|                       | %g                       | The more compact of %e or %f, with no trailing zeros                                                |
|                       | %G                       | The more compact of %E or %f, with no trailing zeros                                                |
|                       | %bx or %bX<br>%bo<br>%bu | Double-precision hexadecimal, octal, or decimal value<br>Example: %bx prints pi as 400921fb54442d18 |
|                       | %tx or %tX<br>%to<br>%tu | Single-precision hexadecimal, octal, or decimal value<br>Example: %tx prints pi as 40490fdb         |
| Characters            | %c                       | Single character                                                                                    |
|                       | %s                       | String of characters                                                                                |

# fprintf

---

The string can include optional operators, which appear in the following order (includes spaces for clarity):

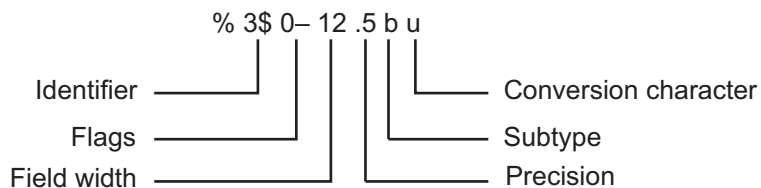

Optional operators include:

- Identifier

Order for processing inputs. Use the syntax  $n\$$ , where  $n$  represents the position of the value in the input list.

For example, '%3\$s %2\$s %1\$s %2\$s' prints inputs 'A', 'B', 'C' as follows: C B A B.

- Flags

- ' ' Left-justify. Example: %-5.2f
- '+' Print sign character (+) for positive values. Example: %+5.2f
- ' ' Pad to field width with spaces before the value. Example: % 5.2f

'0' Pad to field width with zeros. Example: `%05.2f`

'#' Modify selected numeric conversions:

- For `%o`, `%x`, or `%X`, print `0`, `0x`, or `0X` prefix.
- For `%f`, `%e`, or `%E`, print decimal point even when precision is 0.
- For `%g` or `%G`, do not remove trailing zeros or decimal point.

Example: `##5.0f`

- Field width

Minimum number of characters to print. Can be a number, or an asterisk (\*) to refer to an argument in the input list. For example, the input list (`'%12d'`, `intmax`) is equivalent to (`'%*d'`, `12`, `intmax`).

- Precision

For `%f`, `%e`, or `%E`: Number of digits to the right of the decimal point.

Example: `'%6.4f'` prints `pi` as `'3.1416'`

For `%g` or `%G` Number of significant digits.

Example: `'%6.4g'` prints `pi` as `' 3.142'`

Can be a number, or an asterisk (\*) to refer to an argument in the input list. For example, the input list (`'%6.4f'`, `pi`) is equivalent to (`'%*.*f'`, `6`, `4`, `pi`).

The string can also include combinations of the following:

- Literal text to print. To print a single quotation mark, include `'` in `formatSpec`.
- Control characters, including:

# fprintf

---

|                  |                                                                |
|------------------|----------------------------------------------------------------|
| <code>%%</code>  | Percent character                                              |
| <code>\\</code>  | Backslash                                                      |
| <code>\a</code>  | Alarm                                                          |
| <code>\b</code>  | Backspace                                                      |
| <code>\f</code>  | Form feed                                                      |
| <code>\n</code>  | New line                                                       |
| <code>\r</code>  | Carriage return                                                |
| <code>\t</code>  | Horizontal tab                                                 |
| <code>\v</code>  | Vertical tab                                                   |
| <code>\xN</code> | Character whose ASCII code is the hexadecimal number, <i>N</i> |
| <code>\w</code>  | Character whose ASCII code is the octal number, <i>N</i>       |

The following limitations apply to conversions:

- Numeric conversions print only the real component of complex numbers.
- If you specify a conversion that does not fit the data, such as a string conversion for a numeric value, MATLAB overrides the specified conversion, and uses `%e`.
- If you apply a string conversion (`%s`) to integer values, MATLAB converts values that correspond to valid character codes to characters. For example, `'%s'` converts `[65 66 67]` to `ABC`.

## **A1,...,An - Numeric or character arrays**

scalar | vector | matrix | multidimensional array

Numeric or character arrays, specified as a scalar, vector, matrix, or multidimensional array.

**Data Types**

single | double | int8 | int16 | int32 | int64 | uint8 |  
uint16 | uint32 | uint64 | logical | char

**Output Arguments****nbytes - Number of bytes**

scalar

Number of bytes that `fprintf` writes, returned as a scalar. When writing to a file, `nbytes` is determined by the character encoding. When printing data to the screen, `nbytes` is the number of characters displayed on the screen.

**Tips**

- Format specifiers for the reading functions `sscanf` and `fscanf` differ from the formats for the writing functions `sprintf` and `fprintf`. The reading functions do not support a precision field. The width field specifies a minimum for writing but a maximum for reading.

**Examples****Print Literal Text and Array Values**

Print multiple numeric values and literal text to the screen.

```
A1 = [9.9, 9900];
A2 = [8.8, 7.7 ; ...
 8800, 7700];
formatSpec = 'X is %4.2f meters or %8.3f mm\n';
fprintf(formatSpec,A1,A2)
```

```
X is 9.90 meters or 9900.000 mm
X is 8.80 meters or 8800.000 mm
X is 7.70 meters or 7700.000 mm
```

`%4.2f` in the `formatSpec` input specifies that the first value in each line of output is a floating-point number with a field width of four digits, including two digits after the decimal point. `%8.3f` in the `formatSpec` input specifies that the second value in each line of output is a floating-point number with a field width of eight digits, including three digits after the decimal point. `\n` is a control character that starts a new line.

## Print Double-Precision Values as Integers

Explicitly convert double-precision values with fractions to integer values.

```
a = [1.02, 3.04, 5.06];
fprintf('%d\n',round(a));
```

```
1
3
5
```

`%d` in the `formatSpec` input prints each value in the vector, `round(a)`, as a signed integer. `\n` is a control character that starts a new line.

## Write Tabular Data to Text File

Write a short table of the exponential function to a text file called `exp.txt`.

```
x = 0:.1:1;
A = [x; exp(x)];

fileID = fopen('exp.txt','w');
fprintf(fileID,'%6s %12s\n','x','exp(x)');
fprintf(fileID,'%6.2f %12.8f\n',A);
fclose(fileID);
```

The first call to `fprintf` prints header text `x` and `exp(x)`, and the second call prints the values from variable `A`.

If you plan to read the file with Microsoft Notepad, use `\r\n` instead of `\n` to move to a new line. For example, replace the calls to `fprintf` with the following:

```
fprintf(fileID,'%6s %12s\r\n','x','exp(x)');
fprintf(fileID,'%6.2f %12.8f\r\n',A);
```

MATLAB import functions, all UNIX applications, and Microsoft Word and WordPad recognize `\n` as a newline indicator.

View the contents of the file with the `type` command.

```
type exp.txt
```

```
 x exp(x)
0.00 1.00000000
0.10 1.10517092
0.20 1.22140276
0.30 1.34985881
0.40 1.49182470
0.50 1.64872127
0.60 1.82211880
0.70 2.01375271
0.80 2.22554093
0.90 2.45960311
1.00 2.71828183
```

### **Get Number of Bytes Written to File**

Write data to a file and return the number of bytes written.

Write an array of data, `A`, to a file and get the number of bytes that `fprintf` writes.

```
A = magic(4);

fileID = fopen('myfile.txt','w');
nbytes = fprintf(fileID,'%5d %5d %5d %5d\n',A)

nbytes =

 96
```

The `fprintf` function wrote 96 bytes to the file.

Close the file.

```
fclose(fileID);
```

View the contents of the file with the `type` command.

# fprintf

---

```
type('myfile.txt')
```

```
16 5 9 4
 2 11 7 14
 3 10 6 15
13 8 12 1
```

## Display Hyperlinks in Command Window

Display a hyperlink (The MathWorks Web Site) on the screen.

```
site = 'http://www.mathworks.com';
title = 'The MathWorks Web Site';
```

```
fprintf('%s\n',site,title)
```

%s in the formatSpec input indicates that the values of the variables site and title, should be printed as strings.

## References

- [1] Kernighan, B. W., and D. M. Ritchie, *The C Programming Language*, Second Edition, Prentice-Hall, Inc., 1988.
- [2] ANSI specification X3.159-1989: “Programming Language C,” ANSI, 1430 Broadway, New York, NY 10018.

## See Also

disp | fclose | ferror | fopen | fread | fscanf | fwrite | fseek  
| ftell | sprintf

## Related Examples

- “Export Cell Array to Text File”
- “Appending or Overwriting Existing Files”

## Concepts

- “Formatting Strings”



**Purpose** Write text to device

**Syntax**

```
fprintf(obj, 'cmd')
fprintf(obj, 'format', 'cmd')
fprintf(obj, 'cmd', 'mode')
fprintf(obj, 'format', 'cmd', 'mode')
```

**Description** fprintf(obj, 'cmd') writes the string cmd to the device connected to the serial port object, obj. The default format is %s\n. The write operation is synchronous and blocks the command-line until execution completes.

fprintf(obj, 'format', 'cmd') writes the string using the format specified by format.

fprintf(obj, 'cmd', 'mode') writes the string with command line access specified by mode. mode specifies if cmd is written synchronously or asynchronously.

fprintf(obj, 'format', 'cmd', 'mode') writes the string using the specified format. format is a C language conversion specification.

You need an open connection from the serial port object, obj, to the device before performing read or write operations.

Use the fopen function to open a connection to the device. When obj has an open connection to the device it has a Status property value of open. Refer to “Troubleshooting Common Errors” for fprintf errors.

To understand the use of fprintf refer to “Completing a Write Operation with fprintf” and “Rules for Writing the Terminator”.

## Input Arguments

### format

ANSI C conversion specification includes these conversion characters.

| Specifier | Description               |
|-----------|---------------------------|
| %c        | Single character          |
| %d or %i  | Decimal notation (signed) |

# fprintf (serial)

---

| Specifier | Description                                                                       |
|-----------|-----------------------------------------------------------------------------------|
| %e        | Exponential notation (using lowercase e as in 3.1415e+00)                         |
| %E        | Exponential notation (using uppercase E as in 3.1415E+00)                         |
| %f        | Fixed-point notation                                                              |
| %g        | The more compact of %e or %f, as defined above. Insignificant zeros do not print. |
| %G        | Same as %g, but using uppercase E                                                 |
| %o        | Octal notation (unsigned)                                                         |
| %s        | String of characters                                                              |
| %u        | Decimal notation (unsigned)                                                       |
| %x        | Hexadecimal notation (using lowercase letters a–f)                                |
| %X        | Hexadecimal notation (using uppercase letters A–F)                                |

## mode

Specifies whether the string `cmd` is written synchronously or asynchronously:

- `sync`: `cmd` is written synchronously and the command line is blocked.
- `async`: `cmd` is written asynchronously and the command line is not blocked.

If `mode` is not specified, the write operation is synchronous.

If you specify asynchronous `mode`, when the write operation occurs:

- The `BytesToOutput` property value continuously updates to reflect the number of bytes in the output buffer.
- The MATLAB file callback function specified for the `OutputEmptyFcn` property is executed when the output buffer is empty.

Use the `TransferStatus` property to determine whether an asynchronous write operation is in progress.

For more information on synchronous and asynchronous write operations, see [Controlling Access to the MATLAB Command Line](#).

## Examples

Create a serial port object `s` and connect it to a Tektronix TDS 210 oscilloscope. Write the `RS232?` command with `fprintf`. `RS232?` instructs the scope to return serial port communications settings. This example works on a Windows platform.

```
s = serial('COM1');
fopen(s)
fprintf(s, 'RS232?')
```

Specify a format for the data that does not include the terminator, or configure the terminator to empty.

```
s = serial('COM1');
fopen(s)
fprintf(s, '%s', 'RS232?')
```

The default format for `fprintf` is `%s\n`. Therefore, the terminator specified by the `Terminator` property is automatically written. However, in some cases you might want to suppress writing the terminator.

Specify an array of formats and commands:

```
s = serial('COM1');
fopen(s)
fprintf(s, ['ch:%d scale:%d'], [1 20e-3], 'sync');
```

## See Also

[fopen](#) | [fwrite](#) | [stopasync](#) | [BytesToOutput](#) | [OutputBufferSize](#) | [OutputEmptyFcn](#) | [Status](#) | [TransferStatus](#) | [ValuesSent](#)

## Tutorials

- [Writing and Reading Data](#)
- [Controlling Access to the MATLAB Command Line](#)

# frame2im

---

**Purpose** Return image data associated with movie frame

**Syntax** [X,Map] = frame2im(F)

**Description** [X,Map] = frame2im(F) returns the indexed image X and associated colormap Map from the single movie frame F. If the frame contains true-color data, the  $m$ -by- $n$ -3 matrix Map is empty. The functions getframe and im2frame create a movie frame.

**Examples** Create and capture an image using getframe and frame2im:

```
peaks %Make figure
f = getframe; %Capture screen shot
[im,map] = frame2im(f); %Return associated image data
if isempty(map) %Truecolor system
 rgb = im;
else %Indexed system
 rgb = ind2rgb(im,map); %Convert image data
end
```

**See Also** getframe | im2frame | movie

**Purpose**

Read data from binary file

**Syntax**

```
A = fread(fileID)
A = fread(fileID,sizeA)
A = fread(fileID,sizeA,precision)
A = fread(fileID,sizeA,precision,skip)
A = fread(fileID,sizeA,precision,skip,machinefmt)
[A,count] = fread(__)
```

**Description**

`A = fread(fileID)` reads data from an open binary file into column vector `A` and positions the file pointer at the end-of-file marker. The binary file is indicated by the file identifier, `fileID`. Use `fopen` to open the file and obtain the `fileID` value. When you finish reading, close the file by calling `fclose(fileID)`.

`A = fread(fileID,sizeA)` reads file data into an array, `A`, with dimensions, `sizeA`, and positions the file pointer after the last value read. `fread` populates `A` in column order.

`A = fread(fileID,sizeA,precision)` interprets values in the file according to the form and size described by `precision`. The `sizeA` argument is optional.

`A = fread(fileID,sizeA,precision,skip)` skips the number of bytes or bits specified by `skip` after reading each value in the file. The `sizeA` argument is optional.

`A = fread(fileID,sizeA,precision,skip,machinefmt)` additionally specifies the order for reading bytes or bits in the file. The `sizeA` and `skip` arguments are optional.

`[A,count] = fread( __ )` additionally returns the number of characters that `fread` reads into `A`. You can use this syntax with any of the input arguments of the previous syntaxes.

# fread

---

## Input Arguments

### fileID - File identifier

integer

File identifier of an open binary file, specified as an integer. Before reading a file with `fread`, you must use `fopen` to open the file and obtain the `fileID`.

### Data Types

double

### sizeA - Dimensions of output array

Inf (default) | integer | two-element row vector

Dimensions of the output array, `A`, specified as `Inf`, an integer, or a two-element row vector.

| Form of the sizeA Input | Dimensions of the output array, A                                                          |
|-------------------------|--------------------------------------------------------------------------------------------|
| Inf                     | Column vector, with each element containing a value in the file.                           |
| $n$                     | Column vector with $n$ elements.                                                           |
| $[m, n]$                | $m$ -by- $n$ matrix, filled in column order. $n$ can be <code>Inf</code> , but $m$ cannot. |

### precision - Class and size of values to read

'uint8=>double' (default) | string

Class and size in bits of the values to read, specified as a string in one of the following forms. Optionally the input specifies the class of the output matrix, `A`.

| Form of the precision Input                      | Description                                                                                                                                                                                                                                                        |
|--------------------------------------------------|--------------------------------------------------------------------------------------------------------------------------------------------------------------------------------------------------------------------------------------------------------------------|
| <i>source</i>                                    | Input values are of the class specified by <i>source</i> . Output matrix A is class double.<br>Example: 'int16'                                                                                                                                                    |
| <i>source=&gt;output</i>                         | Input values are of the class specified by <i>source</i> . The class of the output matrix, A, is specified by <i>output</i> .<br>Example: 'int8=>char'                                                                                                             |
| <i>*source</i>                                   | The input values and the output matrix, A, are of the class specified by <i>source</i> . For <i>bitn</i> or <i>ubitn</i> precisions, the output has the smallest class that can contain the input.<br>Example: '*ubit18'<br>This is equivalent to 'ubit18=>uint32' |
| <i>N*source</i> or<br><i>N*source=&gt;output</i> | Read <i>N</i> values before skipping the number of bytes specified by the <i>skip</i> argument.<br>Example: '4*int8'                                                                                                                                               |

The following table shows possible values for *source* and *output*.

| <b>Value Type</b>  | <b>Precision</b> | <b>Bits (Bytes)</b> |
|--------------------|------------------|---------------------|
| Integers, unsigned | uint             | 32 (4)              |
|                    | uint8            | 8 (1)               |
|                    | uint16           | 16 (2)              |
|                    | uint32           | 32 (4)              |
|                    | uint64           | 64 (8)              |
|                    | uchar            | 8 (1)               |
|                    | unsigned char    | 8 (1)               |
|                    | ushort           | 16 (2)              |
|                    | ulong            | 32 (4)              |
|                    | ubit <i>n</i>    | $1 \leq n \leq 64$  |
| Integers, signed   | int              | 32 (4)              |
|                    | int8             | 8 (1)               |
|                    | int16            | 16 (2)              |
|                    | int32            | 32 (4)              |
|                    | int64            | 64 (8)              |
|                    | integer*1        | 8 (1)               |
|                    | integer*2        | 16 (2)              |
|                    | integer*4        | 32 (4)              |
|                    | integer*8        | 64 (8)              |
|                    | schar            | 8 (1)               |
|                    | signed char      | 8 (1)               |
|                    | short            | 16 (2)              |
|                    | long             | 32 (4)              |
|                    | bit <i>n</i>     | $1 \leq n \leq 64$  |



| Value Type             | Precision | Bits (Bytes)                                                                      |
|------------------------|-----------|-----------------------------------------------------------------------------------|
| Floating-point numbers | single    | 32 (4)                                                                            |
|                        | double    | 64 (8)                                                                            |
|                        | float     | 32 (4)                                                                            |
|                        | float32   | 32 (4)                                                                            |
|                        | float64   | 64 (8)                                                                            |
|                        | real*4    | 32 (4)                                                                            |
|                        | real*8    | 64 (8)                                                                            |
| Characters             | char*1    | 8 (1)                                                                             |
|                        | char      | Depends on the encoding scheme associated with the file. Set encoding with fopen. |

For most values of *source*, if `fread` reaches the end of the file before reading a complete value, it does not return a result for the final value. However, if *source* is `bitn` or `ubitn`, then `fread` returns a partial result for the final value.

---

**Note** To preserve NaN and Inf values in MATLAB, read and write data of class `double` or `single`.

---

### **skip - Number of bytes to skip**

0 (default) | scalar

Number of bytes to skip after reading each value, specified as a scalar. If you specify a precision of `bitn` or `ubitn`, specify `skip` in bits.

Use the `skip` argument to read data from noncontiguous fields in fixed-length records.

## **machinefmt - Order for reading bytes**

'n' (default) | 'b' | 'l' | 's' | 'a' | ...

Order for reading bytes in the file, specified as one of the strings in the table that follows. For `bitn` and `ubitn` precisions, `machinefmt` specifies the order for reading bits within a byte, but the order for reading bytes remains your system byte ordering.

|                      |                                               |
|----------------------|-----------------------------------------------|
| 'n' or 'native'      | Your system byte ordering (default)           |
| 'b' or 'ieee-be'     | Big-endian ordering                           |
| 'l' or 'ieee-le'     | Little-endian ordering                        |
| 's' or 'ieee-be.164' | Big-endian ordering, 64-bit long data type    |
| 'a' or 'ieee-le.164' | Little-endian ordering, 64-bit long data type |

By default, all currently supported platforms use little-endian ordering for new files. Existing binary files can use either big-endian or little-endian ordering.

## **Output Arguments**

### **A - File data**

column vector | matrix

File data, returned as a column vector. If you specified the `sizeA` argument, then `A` is a matrix of the specified size. Data in `A` is class `double` unless you specify a different class in the `precision` argument.

### **count - Number of characters read**

scalar

Number of characters read, returned as a scalar value.

## **Examples**

### **Read Entire File of uint8 Data**

Write a nine-element vector to a sample file, `nine.bin`.

```
fileID = fopen('nine.bin','w');
```

```
fwrite(fileID,[1:9]);
fclose(fileID);
```

Read all the data in the file into a vector of class `double`. By default, `fread` reads a file 1 byte at a time, interprets each byte as an 8-bit unsigned integer (`uint8`), and returns a `double` array.

```
fileID = fopen('nine.bin');
A = fread(fileID)
```

```
A =
```

```
 1
 2
 3
 4
 5
 6
 7
 8
 9
```

`fread` returns a column vector, with one element for each byte in the file.

View information about A.

```
whos A
```

| Name | Size | Bytes | Class  | Attributes |
|------|------|-------|--------|------------|
| A    | 9x1  | 72    | double |            |

Close the file.

```
fclose(fileID);
```

## Read Entire File of Double-Precision Data

Create a file named `doubledata.bin`, containing nine double-precision values.

```
fileID = fopen('doubledata.bin','w');
fwrite(fileID,magic(3),'double');
fclose(fileID);
```

Open the file, `doubledata.bin`, and read the data in the file into a 3-by-3 array, `A`. Specify that the source data is class `double`.

```
fileID = fopen('doubledata.bin');
A = fread(fileID,[3 3],'double')
```

`A =`

```
 8 1 6
 3 5 7
 4 9 2
```

Close the file.

```
fclose(fileID);
```

## Read Text File

Read the contents of the file, `fread.m`. Transpose the output array, `A` so that it is a row vector.

```
fileID = fopen('fread.m');
A = fread(fileID,'*char')';
fclose(fileID);
```

`fread` returns the character array, `A`.

## Read Selected Rows or Columns from File

Create a file named `nine.bin`, containing the values from 1 to 9. Write the data as `uint16` values.

```
fileID = fopen('nine.bin','w');
fwrite(fileID,[1:9],'uint16');
fclose(fileID);
```

Read the first six values into a 3-by-2 array. Specify that the source data is class `uint16`.

```
fileID = fopen('nine.bin');
A = fread(fileID,[3,2],'uint16')
```

A =

```
 1 4
 2 5
 3 6
```

`fread` returns an array populated column-wise with the first six values from the file, `nine.bin`.

Return to the beginning of the file.

```
frewind(fileID)
```

Read two values at a time, and skip one value before reading the next values. Specify this format using the `precision` value, `'2*uint16'`. Because the data is class `uint16`, one value is represented by 2 bytes. Therefore, specify the `skip` argument as 2.

```
precision = '2*uint16';
skip = 2;
B = fread(fileID,[2,3],precision,skip)
```

B =

```
 1 4 7
 2 5 8
```

`fread` returns a 2-by-3 array populated column-wise with the values from `nine.bin`.

Close the file.

```
fclose(fileID);
```

## Read Digits of Binary Coded Decimal Values

Create a file with binary coded decimal (BCD) values.

```
str = ['AB'; 'CD'; 'EF'; 'FA'];
```

```
fileID = fopen('bcd.bin','w');
fwrite(fileID,hex2dec(str),'ubit8');
fclose(fileID);
```

Read 1 byte at a time.

```
fileID = fopen('bcd.bin');
onebyte = fread(fileID,4,'*ubit8');
```

Display the BCD values.

```
disp(dec2hex(onebyte))
```

```
AB
CD
EF
FA
```

Return to the beginning of the file using `frewind`. If you read 4 bits at a time on a little-endian system, your results appear in the wrong order.

```
frewind(fileID);
```

```
err = fread(fid,8,'*ubit4');
disp(dec2hex(err))
```

B  
A  
D  
C  
F  
E  
A  
F

Return to the beginning of the file using `frewind`. Read the data 4 bits at a time as before, but specify a big-endian ordering to display the correct results.

```
frewind(fileID);

correct = fread(fileID,8,'*ubit4','ieee-be');
disp(dec2hex(correct))
```

A  
B  
C  
D  
E  
F  
F  
A

Close the file.

```
fclose(fileID);
```

## See Also

`fclose` | `fgetl` | `fopen` | `fscanf` | `fprintf` | `fwrite` | `fseek` | `ftell`

## Concepts

- “Reading Portions of a File”
- “Reading Files Created on Other Systems”

# fread (serial)

---

**Purpose** Read binary data from device

**Syntax**  
`A = fread(obj)`  
`A = fread(obj,size,'precision')`  
`[A,count] = fread(...)`  
`[A,count,msg] = fread(...)`

**Description** `A = fread(obj)` and `A = fread(obj,size)` read binary data from the device connected to the serial port object, `obj`, and returns the data to `A`. The maximum number of values to read is specified by `size`. If `size` is not specified, the maximum number of values to read is determined by the object's `InputBufferSize` property. Valid options for `size` are:

|                    |                                                                                                                              |
|--------------------|------------------------------------------------------------------------------------------------------------------------------|
| <code>n</code>     | Read at most <code>n</code> values into a column vector.                                                                     |
| <code>[m,n]</code> | Read at most <code>m</code> -by- <code>n</code> values filling an <code>m</code> -by- <code>n</code> matrix in column order. |

`size` cannot be `inf`, and an error is returned if the specified number of values cannot be stored in the input buffer. You specify the size, in bytes, of the input buffer with the `InputBufferSize` property. A value is defined as a byte multiplied by the *precision* (see below).

`A = fread(obj,size,'precision')` reads binary data with precision specified by *precision*.

*precision* controls the number of bits read for each value and the interpretation of those bits as integer, floating-point, or character values. If *precision* is not specified, `uchar` (an 8-bit unsigned character) is used. By default, numeric values are returned in double-precision arrays. The supported values for *precision* are listed below in Tips.

`[A,count] = fread(...)` returns the number of values read to `count`.

`[A,count,msg] = fread(...)` returns a warning message to `msg` if the read operation was unsuccessful.



## Tips

Before you can read data from the device, it must be connected to `obj` with the `fopen` function. A connected serial port object has a `Status` property value of `open`. An error is returned if you attempt to perform a read operation while `obj` is not connected to the device.

If `msg` is not included as an output argument and the read operation was not successful, then a warning message is returned to the command line.

The `ValuesReceived` property value is increased by the number of values read, each time `fread` is issued.

## Rules for Completing a Binary Read Operation

A read operation with `fread` blocks access to the MATLAB command line until:

- The specified number of values are read.
- The time specified by the `Timeout` property passes.

---

**Note** The `Terminator` property is not used for binary read operations.

---

## Supported Precisions

The supported values for *precision* are listed below.

| Data Type | Precision          | Interpretation                     |
|-----------|--------------------|------------------------------------|
| Character | <code>uchar</code> | 8-bit unsigned character           |
|           | <code>schar</code> | 8-bit signed character             |
|           | <code>char</code>  | 8-bit signed or unsigned character |

# fread (serial)

---

| <b>Data Type</b> | <b>Precision</b> | <b>Interpretation</b>          |
|------------------|------------------|--------------------------------|
| Integer          | int8             | 8-bit integer                  |
|                  | int16            | 16-bit integer                 |
|                  | int32            | 32-bit integer                 |
|                  | uint8            | 8-bit unsigned integer         |
|                  | uint16           | 16-bit unsigned integer        |
|                  | uint32           | 32-bit unsigned integer        |
|                  | short            | 16-bit integer                 |
|                  | int              | 32-bit integer                 |
|                  | long             | 32- or 64-bit integer          |
|                  | ushort           | 16-bit unsigned integer        |
|                  | uint             | 32-bit unsigned integer        |
|                  | ulong            | 32- or 64-bit unsigned integer |
| Floating-point   | single           | 32-bit floating point          |
|                  | float32          | 32-bit floating point          |
|                  | float            | 32-bit floating point          |
|                  | double           | 64-bit floating point          |
|                  | float64          | 64-bit floating point          |

## See Also

fget1 | fgets | fopen | fscanf | BytesAvailable | BytesAvailableFcn | InputBufferSize | Status | Terminator | ValuesReceived

## Purpose

(Will be removed) Facets referenced by only one simplex

---

**Note** `freeBoundary(TriRep)` will be removed in a future release. Use `freeBoundary(triangulation)` instead.

---

`TriRep` will be removed in a future release. Use `triangulation` instead.

---

## Syntax

`FF = freeBoundary(TR)`  
`[FF XF] = freeBoundary(TR)`

## Description

`FF = freeBoundary(TR)` returns a matrix `FF` that represents the free boundary facets of the triangulation. A facet is on the free boundary if it is referenced by only one simplex (triangle/tetrahedron, etc). `FF` is of size `m-by-n`, where `m` is the number of boundary facets and `n` is the number of vertices per facet. The vertices of the facets index into the array of points representing the vertex coordinates `TR.X`. The array `FF` could be empty as in the case of a triangular mesh representing the surface of a sphere.

`[FF XF] = freeBoundary(TR)` returns a matrix of free boundary facets

## Input Arguments

`TR`                      Triangulation representation.

## Output Arguments

`FF`                        `FF` that has vertices defined in terms of a compact array of coordinates `XF`.

`XF`                        `XF` is of size `m-by-ndim` where `m` is the number of free facets, and `ndim` is the dimension of the space where the triangulation resides

## Definitions

A *simplex* is a triangle/tetrahedron or higher-dimensional equivalent. A *facet* is an edge of a triangle or a face of a tetrahedron.

# TriRep.freeBoundary

---

## Examples

### Example 1

Use TriRep to compute the boundary triangulation of an imported triangulation.

Load a 3-D triangulation:

```
load tetmesh;
trep = TriRep(tet, X);
```

Compute the boundary triangulation:

```
[tri xf] = freeBoundary(trep);
```

Plot the boundary triangulation:

```
trisurf(tri, xf(:,1),xf(:,2),xf(:,3), ...
 'FaceColor','cyan', 'FaceAlpha', 0.8);
```

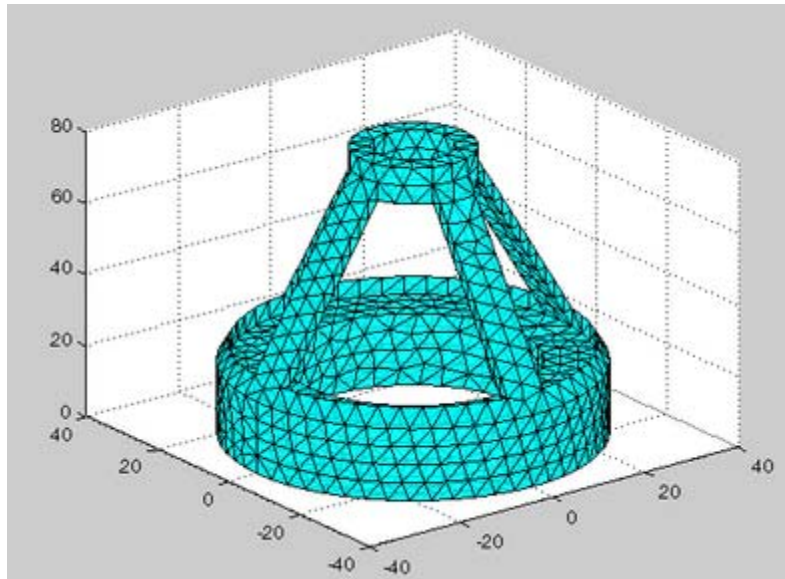

## Example 2

Perform a direct query of a 2-D triangulation created with `DelaunayTri`.

Plot the mesh:

```
x = rand(20,1);
y = rand(20,1);
dt = DelaunayTri(x,y);
fe = freeBoundary(dt)';
triplot(dt);
hold on;
```

Display the free boundary edges in red:

```
plot(x(fe), y(fe), '-r', 'LineWidth',2) ;
hold off;
```

In this instance the free edges correspond to the convex hull of  $(x, y)$ .

# TriRep.freeBoundary

---

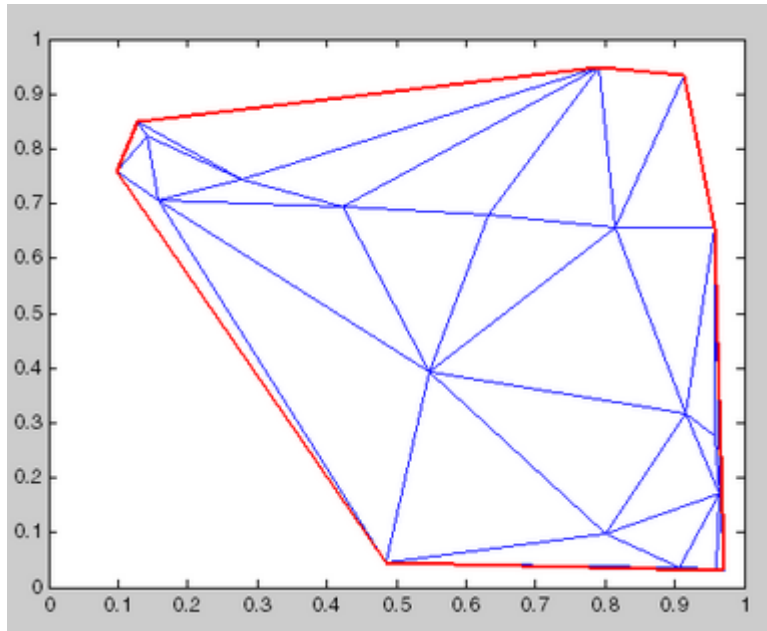

## See Also

[delaunayTriangulation](#) | [convexHull](#) | [featureEdges](#) | [faceNormal](#)  
| [triangulation](#)

**Purpose** Frequency spacing for frequency response

**Syntax**

```
[f1,f2] = freqspace(n)
[f1,f2] = freqspace([m n])
[x1,y1] = freqspace(...,'meshgrid')
f = freqspace(N)
f = freqspace(N,'whole')
```

**Description** `freqspace` returns the implied frequency range for equally spaced frequency responses. `freqspace` is useful when creating desired frequency responses for various one- and two-dimensional applications.

`[f1,f2] = freqspace(n)` returns the two-dimensional frequency vectors `f1` and `f2` for an `n`-by-`n` matrix.

For `n` odd, both `f1` and `f2` are `[-n+1:2:n-1]/n`.

For `n` even, both `f1` and `f2` are `[-n:2:n-2]/n`.

`[f1,f2] = freqspace([m n])` returns the two-dimensional frequency vectors `f1` and `f2` for an `m`-by-`n` matrix.

`[x1,y1] = freqspace(...,'meshgrid')` is equivalent to

```
[f1,f2] = freqspace(...);
[x1,y1] = meshgrid(f1,f2);
```

`f = freqspace(N)` returns the one-dimensional frequency vector `f` assuming `N` evenly spaced points around the unit circle. For `N` even or odd, `f` is `(0:2/N:1)`. For `N` even, `freqspace` therefore returns  $(N+2)/2$  points. For `N` odd, it returns  $(N+1)/2$  points.

`f = freqspace(N,'whole')` returns `N` evenly spaced points around the whole unit circle. In this case, `f` is `0:2/N:2*(N-1)/N`.

**See Also** `meshgrid`

# frewind

---

**Purpose** Move file position indicator to beginning of open file

**Syntax** `frewind(fileID)`

**Description** `frewind(fileID)` sets the file position indicator to the beginning of a file. *fileID* is an integer file identifier obtained from `fopen`.

If the file is on a tape device and the rewind operation fails, `frewind` does not return an error message.

**Alternatives** `frewind(fileID)` is equivalent to:

```
fseek(fileID, 0, 'bof');
```

**See Also** `fclose` | `feof` | `ferror` | `fopen` | `fseek` | `ftell` | `fscanf` | `fprintf` | `fread` | `fwrite`



**Purpose**

Read data from text file

**Syntax**

```
A = fscanf(fileID,formatSpec)
A = fscanf(fileID,formatSpec,sizeA)
[A,count] = fscanf(___)
```

**Description**

`A = fscanf(fileID,formatSpec)` reads data from an open text file into column vector `A` and interprets values in the file according to the format specified by `formatSpec`. The `fscanf` function reapplies the format throughout the entire file and positions the file pointer at the end-of-file marker. If `fscanf` cannot match `formatSpec` to the data, it reads only the portion that matches and stops processing.

The text file is indicated by the file identifier, `fileID`. Use `fopen` to open the file, specify the character encoding, and obtain the `fileID` value. When you finish reading, close the file by calling `fclose(fileID)`.

`A = fscanf(fileID,formatSpec,sizeA)` reads file data into an array, `A`, with dimensions, `sizeA`, and positions the file pointer after the last value read. `fscanf` populates `A` in column order.

`[A,count] = fscanf( ___ )` additionally returns the number of fields that `fscanf` reads into `A`. For numeric data, this is the number of values read. You can use this syntax with any of the input arguments of the previous syntaxes.

**Input Arguments****fileID - File identifier**

integer

File identifier of an open text file, specified as an integer. Before reading a file with `fscanf`, you must use `fopen` to open the file and obtain the `fileID`.

**Data Types**

double

**formatSpec - Format of data fields**

# fscanf

string

Format of the data fields in the file, specified as a string of one or more conversion specifiers. When `fscanf` reads a file, it attempts to match the data to the `formatSpec` string.

## Numeric Fields

This table lists available conversion specifiers for numeric inputs. `fscanf` converts values to their decimal (base 10) representation.

| Numeric Field Type    | Conversion Specifier | Details                                                                                                                                                                                                                                                                            |
|-----------------------|----------------------|------------------------------------------------------------------------------------------------------------------------------------------------------------------------------------------------------------------------------------------------------------------------------------|
| Integer, signed       | %d                   | Base 10                                                                                                                                                                                                                                                                            |
|                       | %i                   | The values in the file determine the base: <ul style="list-style-type: none"><li>• The default is base 10.</li><li>• If the initial digits are 0x or 0X, then the values are hexadecimal (base 16).</li><li>• If the initial digit is 0, then values are octal (base 8).</li></ul> |
|                       | %ld or %li           | 64-bit values, base 10, 8, or 16                                                                                                                                                                                                                                                   |
| Integer, unsigned     | %u                   | Base 10                                                                                                                                                                                                                                                                            |
|                       | %o                   | Base 8 (octal)                                                                                                                                                                                                                                                                     |
|                       | %x                   | Base 16 (hexadecimal)                                                                                                                                                                                                                                                              |
|                       | %lu, %lo, %lx        | 64-bit values, base 10, 8, or 16                                                                                                                                                                                                                                                   |
| Floating-point number | %f                   | Floating-point fields can contain any of the following (not case sensitive): Inf, -Inf, NaN, or -NaN.                                                                                                                                                                              |
|                       | %e                   |                                                                                                                                                                                                                                                                                    |
|                       | %g                   |                                                                                                                                                                                                                                                                                    |

## Character Fields

This table lists available conversion specifiers for character inputs.

| Character Field Type    | Conversion Specifier | Description                                                                                                                                  |
|-------------------------|----------------------|----------------------------------------------------------------------------------------------------------------------------------------------|
| Characters              | %s                   | Read a string until fscanf encounters white space.                                                                                           |
|                         | %c                   | Read any single character, including white space.<br>To read multiple characters at a time, specify field width.                             |
| Pattern-matching string | %[...]               | Read only characters in the brackets up to the first nonmatching character or white space.<br><br>Example: %[mus] reads 'summer ' as 'summ'. |

If formatSpec contains a combination of numeric and character specifiers, then fscanf converts each character to its numeric equivalent. This conversion occurs even when the format explicitly skips all numeric values (for example, formatSpec is '%\*d %s').

### Optional Operators

- Fields and Characters to Ignore

fscanf reads all numeric values and characters in your file in sequence, unless you tell it to ignore a particular field or a portion of a field. To skip fields, insert an asterisk (\*) after the percent sign (%). For example, to skip integers, specify %\*d.

- Field Width

To specify the maximum number of digits or text characters to read at a time, insert a number after the percent character. For example,

# fscanf

---

`%10c` reads up to 10 characters at a time, including white space. `%4f` reads up to 4 digits at a time, including the decimal point.

- Literal Text to Ignore

`fscanf` ignores specified text appended to the `formatSpec` string.

Example: `Level%u` reads 'Level1' as 1.

Example: `%uStep` reads '2Step' as 2.

## sizeA - Dimensions of output array

`Inf` (default) | integer | two-element row vector

Dimensions of the output array, `A`, specified as `Inf`, an integer, or a two-element row vector.

| Form of the <code>sizeA</code> Input | Description                                                                                                                                                                                                                        |
|--------------------------------------|------------------------------------------------------------------------------------------------------------------------------------------------------------------------------------------------------------------------------------|
| <code>Inf</code>                     | Read to the end of the file.<br>For numeric data, the output, <code>A</code> , is a column vector.<br>For text data, <code>A</code> is a string.                                                                                   |
| <code>n</code>                       | Read at most <code>n</code> numeric values or character fields.<br>For numeric data, the output, <code>A</code> , is a column vector.<br>For text data, <code>A</code> , is a string.                                              |
| <code>[m, n]</code>                  | Read at most <code>m*n</code> numeric values or character fields. <code>n</code> can be <code>Inf</code> , but <code>m</code> cannot. The output, <code>A</code> , is <code>m</code> -by- <code>n</code> , filled in column order. |

## Output Arguments

### A - File data

column vector | matrix | string | character array

File data, returned as a column vector, matrix, string, or character array. The class and size of `A` depend on the `formatSpec` input:

- If `formatSpec` contains only numeric specifiers, then `A` is numeric. If you specify the `sizeA` argument, then `A` is a matrix of the specified size. Otherwise, `A` is a column vector. If the input contains fewer than `sizeA` values, then `fscanf` pads `A` with zeros.
  - If `formatSpec` contains only 64-bit signed integer specifiers, then `A` is of class `int64`.
  - If `formatSpec` contains only 64-bit unsigned integer specifiers, then `A` is of class `uint64`.
  - Otherwise, `A` is of class `double`.
- If `formatSpec` contains only character or string specifiers (`%c` or `%s`), then `A` is a character array. If you specify `sizeA` and the input contains fewer characters, then `fscanf` pads `A` with `char(0)`.
- If `formatSpec` contains a combination of numeric and character specifiers, then `A` is numeric, of class `double`, and `fscanf` converts each text characters to its numeric equivalent. This occurs even when `formatSpec` explicitly skips all numeric fields (for example, `formatSpec` is `'%*d %s'`).
- If MATLAB cannot match the file data to `formatSpec`, then `A` can be numeric or a character array. The class of `A` depends on the values that `fscanf` reads before it stops processing.

**count - Number of characters read**

scalar

Number of characters read, returned as a scalar value.

**Examples****Read File Contents into Column Vector**

Create a sample text file that contains floating-point numbers.

```
x = 100*rand(8,1);
fileID = fopen('nums1.txt','w');
fprintf(fileID,'%4.4f\n',x);
fclose(fileID);
```

# fscanf

---

View the contents of the file.

```
type nums1.txt
```

```
81.4724
90.5792
12.6987
91.3376
63.2359
9.7540
27.8498
54.6882
```

Open the file for reading, and obtain the file identifier, `fileID`.

```
fileID = fopen('nums1.txt','r');
```

Define the format of the data to read. Use the string, `'%f'`, to specify floating-point numbers.

```
formatSpec = '%f';
```

Read the file data, filling output array, `A`, in column order. `fscanf` reapplies the format, `formatSpec`, throughout the file.

```
A = fscanf(fileID,formatSpec)
```

```
A =
```

```
81.4724
90.5792
12.6987
91.3376
63.2359
9.7540
```

```
27.8498
54.6882
```

A is a column vector containing data from the file.

Close the file.

```
fclose(fileID);
```

### Read File Contents into Array

Create a sample text file that contains integers and floating-point numbers.

```
x = 1:1:5;
y = [x;rand(1,5)];
fileID = fopen('nums2.txt','w');
fprintf(fileID,'%d %4.4f\n',y);
fclose(fileID);
```

View the contents of the file.

```
type nums2.txt
```

```
1 0.8147
2 0.9058
3 0.1270
4 0.9134
5 0.6324
```

Open the file for reading, and obtain the file identifier, `fileID`.

```
fileID = fopen('nums2.txt','r');
```

Define the format of the data to read and the shape of the output array.

# fscanf

---

```
formatSpec = '%d %f';
sizeA = [2 Inf];
```

Read the file data, filling output array, A, in column order. `fscanf` reuses the format, `formatSpec`, throughout the file.

```
A = fscanf(fileID,formatSpec,sizeA)
fclose(fileID);
```

A =

```
 1.0000 2.0000 3.0000 4.0000 5.0000
 0.8147 0.9058 0.1270 0.9134 0.6324
```

Transpose the array so that A matches the orientation of the data in the file.

```
A = A'
```

A =

```
 1.0000 0.8147
 2.0000 0.9058
 3.0000 0.1270
 4.0000 0.9134
 5.0000 0.6324
```

## Skip Specific Characters in File

Skip specific characters in a sample file, and return only numeric data.

Create a sample text file containing temperature values.

```
str = '78 C 72 C 64 C 66 C 49 C';
```



```
fileID = fopen('temperature.dat','w');
fprintf(fileID,'%s',str);
fclose(fileID);
```

Read the numbers in the file, skipping the text, °C. Also return the number of values that `fscanf` reads. The extended ASCII code 176 represents the degree sign.

```
fileID = fopen('temperature.dat','r');
degrees = char(176);
[A,count] = fscanf(fileID, ['%d' degrees 'C'])
fclose(fileID);
```

```
A =
```

```
 78
 72
 64
 66
 49
```

```
count =
```

```
 5
```

A is a vector containing the numeric values in the file. `count` indicates that `fscanf` read five values.

## Tips

- Format specifiers for the reading functions `sscanf` and `fscanf` differ from the formats for the writing functions `sprintf` and `fprintf`. The reading functions do not support a precision field. The width field specifies a minimum for writing but a maximum for reading.

## Algorithms

MATLAB reads characters using the encoding scheme associated with the file. You specify the encoding when you open the file using the `fopen` function.

# fscanf

---

## See Also

[fopen](#) | [fprintf](#) | [textscan](#) | [sscanf](#) | [fgetl](#) | [fgets](#) | [fread](#)

## Concepts

- “Reading Data in a Formatted Pattern”
- “Opening Files with Different Character Encodings”

**Purpose** Read data from device, and format as text

**Syntax**

```
A = fscanf(obj)
A = fscanf(obj, 'format')
A = fscanf(obj, 'format', size)
[A, count] = fscanf(...)
[A, count, msg] = fscanf(...)
```

**Description** `A = fscanf(obj)` reads data from the device connected to the serial port object, `obj`, and returns it to `A`. The data is converted to text using the `%c` format.

`A = fscanf(obj, 'format')` reads data and converts it according to `format`. `format` is a C language conversion specification. Conversion specifications involve the `%` character and the conversion characters `d`, `i`, `o`, `u`, `x`, `X`, `f`, `e`, `E`, `g`, `G`, `c`, and `s`. Refer to the `sscanf` file I/O format specifications or a C manual for more information.

`A = fscanf(obj, 'format', size)` reads the number of values specified by `size`. Valid options for `size` are:

|                    |                                                                                                                              |
|--------------------|------------------------------------------------------------------------------------------------------------------------------|
| <code>n</code>     | Read at most <code>n</code> values into a column vector.                                                                     |
| <code>[m,n]</code> | Read at most <code>m</code> -by- <code>n</code> values filling an <code>m</code> -by- <code>n</code> matrix in column order. |

`size` cannot be `inf`, and an error is returned if the specified number of values cannot be stored in the input buffer. If `size` is not of the form `[m,n]`, and a character conversion is specified, then `A` is returned as a row vector. You specify the size, in bytes, of the input buffer with the `InputBufferSize` property. An ASCII value is one byte.

`[A, count] = fscanf(...)` returns the number of values read to `count`.

`[A, count, msg] = fscanf(...)` returns a warning message to `msg` if the read operation did not complete successfully.

# fscanf (serial)

---

## Tips

Before you can read data from the device, it must be connected to `obj` with the `fopen` function. A connected serial port object has a `Status` property value of `open`. An error is returned if you attempt to perform a read operation while `obj` is not connected to the device.

If `msg` is not included as an output argument and the read operation was not successful, then a warning message is returned to the command line.

The `ValuesReceived` property value is increased by the number of values read – including the terminator – each time `fscanf` is issued.

## Rules for Completing a Read Operation with fscanf

A read operation with `fscanf` blocks access to the MATLAB command line until:

- The terminator specified by the `Terminator` property is read.
- The time specified by the `Timeout` property passes.
- The number of values specified by `size` is read.
- The input buffer is filled (unless `size` is specified)

## Examples

Create the serial port object `s` and connect `s` to a Tektronix TDS 210 oscilloscope, which is displaying sine wave. This example works on a Windows platform.

```
s = serial('COM1');
fopen(s)
```

Use the `fprintf` function to configure the scope to measure the peak-to-peak voltage of the sine wave, return the measurement type, and return the peak-to-peak voltage.

```
fprintf(s,'MEASUREMENT:IMMED:TYPE PK2PK')
fprintf(s,'MEASUREMENT:IMMED:TYPE?')
fprintf(s,'MEASUREMENT:IMMED:VALUE?')
```

Because the default value for the `ReadAsyncMode` property is `continuous`, data associated with the two query commands is automatically returned to the input buffer.

```
s.BytesAvailable
```

```
ans =
 21
```

Use `fscanf` to read the measurement type. The operation will complete when the first terminator is read.

```
meas = fscanf(s)
```

```
meas =
PK2PK
```

Use `fscanf` to read the peak-to-peak voltage as a floating-point number, and exclude the terminator.

```
pk2pk = fscanf(s, '%e', 14)
```

```
pk2pk =
 2.0200
```

Disconnect `s` from the scope, and remove `s` from memory and the workspace.

```
fclose(s)
delete(s)
clear s
```

## See Also

```
fgetl | fgets | fopen | fread | textscan | BytesAvailable |
BytesAvailableFcn | InputBufferSize | Status | Terminator |
Timeout
```

# fseek

---

**Purpose** Move to specified position in file

**Syntax** `fseek(fileID, offset, origin)`  
`status = fseek(fileID, offset, origin)`

**Description** `fseek(fileID, offset, origin)` sets the file position indicator `offset` bytes from `origin` in the specified file.  
`status = fseek(fileID, offset, origin)` returns 0 when the operation is successful. Otherwise, it returns -1.

**Input Arguments**

**fileID**

Integer file identifier obtained from `fopen`.

**offset**

Number of bytes to move from `origin`. Can be positive, negative, or zero. The  $n$  bytes of a given file are in positions 0 through  $n-1$ .

**origin**

Starting location in the file:

|             |                          |
|-------------|--------------------------|
| 'bof' or -1 | Beginning of file        |
| 'cof' or 0  | Current position in file |
| 'eof' or 1  | End of file              |

**Examples**

Copy 5 bytes from the file `test1.dat`, starting at the tenth byte, and append to the end of `test2.dat`:

```
% Create files test1.dat and test2.dat
% Each character uses 8 bits (1 byte)

fid1 = fopen('test1.dat', 'w+');
fwrite(fid1, 'ABCDEFGHIJKLMNOPQRSTUVWXYZ');
```

```
fid2 = fopen('test2.dat', 'w+');
fwrite(fid2, 'Second File');

% Seek to the 10th byte ('J'), read 5
fseek(fid1, 9, 'bof');
A = fread(fid1, 5, 'uint8=>char');
fclose(fid1);

% Append to test2.dat
fseek(fid2, 0, 'eof');
fwrite(fid2, A);
fclose(fid2);
```

**Alternatives**

To move to the beginning of a file, call

```
frewind(fileID)
```

This call is identical to

```
fseek(fileID, 0, 'bof')
```

**See Also**

`fclose` | `feof` | `ferror` | `fopen` | `frewind` | `ftell` | `fscanf` | `fprintf`  
| `fread` | `fwrite`

**How To**

- “Reading Portions of a File”

# ftell

---

**Purpose**            Position in open file

**Syntax**            *position* = ftell(*fileID*)

**Description**        *position* = ftell(*fileID*) returns the current position in the specified file. *position* is a zero-based integer that indicates the number of bytes from the beginning of the file. If the query is unsuccessful, *position* is -1. *fileID* is an integer file identifier obtained from fopen.

**See Also**            fclose | feof | ferrord | fopen | frewind | fseek | fscanf | fprintf  
                         | fread | fwrite



**Purpose**

Connect to FTP server

**Description**

Connect to an FTP server by calling the `ftp` function, which creates an FTP object. Perform file operations using methods on the FTP object, such as `mput` and `mget`. When you finish accessing the server, call the `close` method to close the connection.

**Construction**

`f = ftp(host,username,password)` connects to the FTP server `host` and creates FTP object `f`. If the host supports anonymous connections, you can use the `host` argument alone. To specify an alternate port, separate it from `host` with a colon (`:`).

**Input Arguments****host**

String enclosed in single quotation marks that specifies the FTP server.

**username**

String enclosed in single quotation marks that specifies your user name for the FTP server.

**password**

String enclosed in single quotation marks that specifies your password for the FTP server. Because FTP is not a secure protocol, others can see your user name and password.

**Methods**

|                     |                                             |
|---------------------|---------------------------------------------|
| <code>ascii</code>  | Set FTP transfer type to ASCII              |
| <code>binary</code> | Set FTP transfer type to binary             |
| <code>cd</code>     | Change or view current folder on FTP server |
| <code>close</code>  | Close connection to FTP server              |
| <code>delete</code> | Remove file on FTP server                   |

|                     |                                       |
|---------------------|---------------------------------------|
| <code>dir</code>    | View contents of folder on FTP server |
| <code>mget</code>   | Download files from FTP server        |
| <code>mkdir</code>  | Create folder on FTP server           |
| <code>mput</code>   | Upload file or folder to FTP server   |
| <code>rename</code> | Rename file on FTP server             |
| <code>rmdir</code>  | Remove folder on FTP server           |

## Copy Semantics

Handle. To learn how handle classes affect copy operations, see Copying Objects in the MATLAB documentation.

## Examples

Connect to the MathWorks FTP server, and display the FTP object:

```
mw=ftp('ftp.mathworks.com');
disp(mw)
```

MATLAB returns:

```
FTP Object
 host: ftp.mathworks.com
 user: anonymous
 dir: /
 mode: binary
```

---

Connect to port 34 (not supported at `ftp.mathworks.com`, so this code returns an error):

```
mw=ftp('ftp.mathworks.com:34')
```

---

Modify the following code to connect to a host that requires a password:

```
test=ftp('ftp.testsite.com','myname','mypassword')
```

**Algorithms**

The `ftp` function is based on code from the Apache Jakarta Project.

**See Also**

`urlwrite`

**How To**

- “Specify Proxy Server Settings for Connecting to the Internet”

# full

---

**Purpose** Convert sparse matrix to full matrix

**Syntax** `A = full(S)`

**Description** `A = full(S)` converts a sparse matrix `S` to full storage organization, such that `issparse(A)` returns logical 0 (false). If `S` is a full matrix, then `A` is identical to `S`.

**Tips** If `X` is an `m`-by-`n` matrix with `nz` nonzero elements then `full(X)` requires space to store `m*n` elements. On the other hand, `sparse(X)` requires space to store `nz` elements and `(nz+n+1)` integers.

The density of a matrix (`nnz(X)/numel(X)`) determines whether or not it is more efficient to store the matrix as sparse or full. The exact crossover point depends on the matrix class as well as the platform. For example, in 32-bit MATLAB, a double sparse matrix with less than about 2/3 density will require less space than the same matrix in full storage. In 64-bit MATLAB, however, double matrices with less than half of their elements nonzero are more efficient to store as sparse matrices.

**Examples** Here is an example of a sparse matrix with a density of about two-thirds. `sparse(S)` and `full(S)` require about the same number of bytes of storage.

```
S = sparse+(rand(200,200) < 2/3);
A = full(S);
whos
Name Size Bytes Class
 A 200X200 320000 double array
 S 200X200 318432 double array (sparse)
```

**See Also** `issparse` | `sparse`

|                        |                                                                                                                                                                                                                                                                                                                                                                                                                                                                                                                                                                                                                                                                            |
|------------------------|----------------------------------------------------------------------------------------------------------------------------------------------------------------------------------------------------------------------------------------------------------------------------------------------------------------------------------------------------------------------------------------------------------------------------------------------------------------------------------------------------------------------------------------------------------------------------------------------------------------------------------------------------------------------------|
| <b>Purpose</b>         | Build full file name from parts                                                                                                                                                                                                                                                                                                                                                                                                                                                                                                                                                                                                                                            |
| <b>Syntax</b>          | <code>f = fullfile(filepart1,...,filepartN)</code>                                                                                                                                                                                                                                                                                                                                                                                                                                                                                                                                                                                                                         |
| <b>Description</b>     | <p><code>f = fullfile(filepart1,...,filepartN)</code> builds a full file specification, <code>f</code>, from the folders and file names specified. <code>fullfile</code> inserts platform-dependent file separators where necessary, and does not add a trailing file separator. The output of <code>fullfile</code> is conceptually equivalent to</p> <pre>f = [filepart1 filesep filepart2 filesep ... filesep filepartN]</pre>                                                                                                                                                                                                                                          |
| <b>Input Arguments</b> | <p><b>filepart1,...,filepartN - Folder and file names</b><br/>strings   cell arrays of strings</p> <p>Folder and file names, specified as strings and cell arrays of strings. Any nonscalar cell arrays must be of the same size.</p> <p><b>Example:</b> 'folder1','folder2','myfile.m'</p> <p><b>Example:</b><br/>{'folder1';'folder2'},{'subfolder1';'subfolder2'},'myfile.m'</p>                                                                                                                                                                                                                                                                                        |
| <b>Examples</b>        | <p><b>Create a Full File Name</b></p> <pre>f = fullfile('myfolder','mysubfolder','myfile.m')</pre> <pre>f =<br/>myfolder\mysubfolder\myfile.m</pre> <p><code>fullfile</code> returns a string containing the full path to the file. On Windows platforms, the file separator character is a backslash, \. On other platforms, the file separator might be a different character.</p> <p><b>Create Paths to Multiple Files</b></p> <pre>f = fullfile(toolboxdir('matlab'),'iofun',{'filesep.m';'fullfile.m'})</pre> <p><code>fullfile</code> returns a cell array containing a path to the file <code>filesep.m</code>, and a path to the file <code>fullfile.m</code>.</p> |

# fullfile

---

## Create a Path to a Folder

```
f = fullfile(matlabroot,'toolbox','matlab',filesep);
```

fullfile does not trim a leading or trailing filesep.

## See Also

[fileparts](#) | [filesep](#) | [path](#) | [pathsep](#) | [genpath](#)

|                    |                                                                                                                                                                                                                                                                                                                                                                                                                                                                                                                                                                                                                                                                                                              |
|--------------------|--------------------------------------------------------------------------------------------------------------------------------------------------------------------------------------------------------------------------------------------------------------------------------------------------------------------------------------------------------------------------------------------------------------------------------------------------------------------------------------------------------------------------------------------------------------------------------------------------------------------------------------------------------------------------------------------------------------|
| <b>Purpose</b>     | Construct function name string from function handle                                                                                                                                                                                                                                                                                                                                                                                                                                                                                                                                                                                                                                                          |
| <b>Syntax</b>      | <code>func2str(fhandle)</code>                                                                                                                                                                                                                                                                                                                                                                                                                                                                                                                                                                                                                                                                               |
| <b>Description</b> | <p><code>func2str(fhandle)</code> constructs a string <code>s</code> that holds the name of the function to which the function handle <code>fhandle</code> belongs.</p> <p>When you need to perform a string operation, such as compare or display, on a function handle, you can use <code>func2str</code> to construct a string bearing the function name.</p> <p>The <code>func2str</code> command does not operate on nonscalar function handles. Passing a nonscalar function handle to <code>func2str</code> results in an error.</p>                                                                                                                                                                  |
| <b>Tips</b>        | Any variables and their values originally stored in a function handle when it was created are lost if you convert the function handle to a string and back again using the <code>func2str</code> and <code>str2func</code> functions.                                                                                                                                                                                                                                                                                                                                                                                                                                                                        |
| <b>Examples</b>    | <p><b>Example 1</b></p> <p>Convert a <code>sin</code> function handle to a string:</p> <pre>fhandle = @sin;  func2str(fhandle) ans =     sin</pre> <p><b>Example 2</b></p> <p>The <code>catcherr</code> function shown here accepts function handle and data arguments and attempts to evaluate the function through its handle. If the function fails to execute, <code>catcherr</code> uses <code>sprintf</code> to display an error message giving the name of the failing function. The function name must be a string for <code>sprintf</code> to display it. The code derives the function name from the function handle using <code>func2str</code>:</p> <pre>function catcherr(func, data) try</pre> |

## func2str

---

```
 ans = func(data);
 disp('Answer is:');
 ans
 catch
 disp(sprintf('Error executing function '%s'\n', ...
 func2str(func)))
 end
```

The first call to `catcherr` passes a handle to the `round` function and a valid data argument. This call succeeds and returns the expected answer. The second call passes the same function handle and an improper data type (a MATLAB structure). This time, `round` fails, causing `catcherr` to display an error message that includes the failing function name:

```
catcherr(@round, 5.432)
ans =
Answer is 5

xstruct.value = 5.432;
catcherr(@round, xstruct)
Error executing function "round"
```

### See Also

[function\\_handle](#) | [str2func](#) | [functions](#)



**Purpose** Declare function name, inputs, and outputs

**Syntax** `function [y1,...,yN] = myfun(x1,...,xM)`

**Description** `function [y1,...,yN] = myfun(x1,...,xM)` declares a function named `myfun` that accepts inputs `x1,...,xM` and returns outputs `y1,...,yN`. This declaration statement must be the first executable line of the function.

Save the function code in a text file with a `.m` extension. The name of the file should match the name of the first function in the file. Valid function names begin with an alphabetic character, and can contain letters, numbers, or underscores.

You can declare multiple local functions within the same file, or nest functions. If any function in a file contains a nested function, all functions in the file must use the `end` keyword to indicate the end of the function. Otherwise, the `end` keyword is optional.

## Examples **Function with One Output**

Define a function in a file named `average.m` that accepts an input vector, calculates the average of the values, and returns a single result.

```
function y = average(x)
if ~isvector(x)
 error('Input must be a vector')
end
y = sum(x)/length(x);
end
```

Call the function from the command line.

```
z = 1:99;
average(z)
```

```
ans =
 50
```

## Function with Multiple Outputs

Define a function in a file named `stat.m` that returns the mean and standard deviation of an input vector.

```
function [m,s] = stat(x)
n = length(x);
m = sum(x)/n;
s = sqrt(sum((x-m).^2/n));
end
```

Call the function from the command line.

```
values = [12.7, 45.4, 98.9, 26.6, 53.1];
[ave,stdev] = stat(values)
```

```
ave =
 47.3400
stdev =
 29.4124
```

## Multiple Functions in a File

Define two functions in a file named `stat2.m`, where the first function calls the second.

```
function [m,s] = stat2(x)
n = length(x);
m = avg(x,n);
s = sqrt(sum((x-m).^2/n));
end
```

```
function m = avg(x,n)
m = sum(x)/n;
end
```

Function `avg` is a *local function*. Local functions are only available to other functions within the same file.

Call function `stat2` from the command line.

```
values = [12.7, 45.4, 98.9, 26.6, 53.1];
[ave,stdev] = stat2(values)
```

```
ave =
 47.3400
stdev =
 29.4124
```

## See Also

[nargin](#) | [nargout](#) | [pcode](#) | [return](#) | [varargin](#) | [varargout](#) | [what](#)  
| [which](#)

## Related Examples

- “Create Functions in Files”

## Concepts

- “Local Functions”
- “Nested Functions”
- “Base and Function Workspaces”
- “Function Precedence Order”

# function\_handle (@)

---

**Purpose** Handle used in calling functions indirectly

**Syntax** `handle = @functionname`  
`handle = @(arglist)anonymous_function`

**Description** `handle = @functionname` returns a handle to the specified MATLAB function.

A function handle is a MATLAB value that provides a means of calling a function indirectly. You can pass function handles in calls to other functions (often called *function functions*). You can also store function handles in data structures for later use (for example, as Handle Graphics callbacks). A function handle is one of the standard MATLAB data types.

At the time you create a function handle, the function you specify must be on the MATLAB path and in the current scope of the code creating the handle. For example, you can create a handle to a local function as long as you do so from within the file that defines that local function. This condition does not apply when you evaluate the function handle. You can, for example, execute a local function from a separate (out-of-scope) file using a function handle. This requires that the handle was created by the local function (in-scope).

`handle = @(arglist)anonymous_function` constructs an anonymous function and returns a handle to that function. The body of the function, to the right of the parentheses, is a single MATLAB statement or command. `arglist` is a comma-separated list of input arguments. Execute the function by calling it by means of the function handle, `handle`.

**Tips** The function handle is a standard MATLAB data type. As such, you can manipulate and operate on function handles in the same manner as on other MATLAB data types. This includes using function handles in structures and cell arrays:

```
S.a = @sin; S.b = @cos; S.c = @tan;
C = {@sin, @cos, @tan};
```

However, standard matrices or arrays of function handles are not supported:

```
A = [@sin, @cos, @tan]; % This is not supported
```

For nonoverloaded functions, local functions, and private functions, a function handle references just the one function specified in the @functionname syntax. When you evaluate an overloaded function by means of its handle, the arguments the handle is evaluated with determine the actual function that MATLAB dispatches to.

Use `isa(h, 'function_handle')` to see if variable `h` is a function handle.

## Examples

### Example 1 – Constructing a Handle to a Named Function

The following example creates a function handle for the `humps` function and assigns it to the variable `fhandle`.

```
fhandle = @humps;
```

Pass the handle to another function in the same way you would pass any argument. This example passes the function handle just created to `fminbnd`, which then minimizes over the interval `[0.3, 1]`.

```
x = fminbnd(fhandle, 0.3, 1)
x =
 0.6370
```

The `fminbnd` function evaluates the `@humps` function handle. A small portion of the `fminbnd` file is shown below. In line 1, the `funfcn` input parameter receives the function handle `@humps` that was passed in. The statement, in line 113, evaluates the handle.

```
1 function [xf,fval,exitflag,output] = ...
 fminbnd(funfcn,ax,bx,options,varargin)
 .
 .
 .
```

## function\_handle (@)

---

```
113 fx = funfcn(x,varargin{:});
```

### **Example 2 – Constructing a Handle to an Anonymous Function**

The statement below creates an anonymous function that finds the square of a number. When you call this function, MATLAB assigns the value you pass in to variable `x`, and then uses `x` in the equation `x.^2`:

```
sqr = @(x) x.^2;
```

The `@` operator constructs a function handle for this function, and assigns the handle to the output variable `sqr`. As with any function handle, you execute the function associated with it by specifying the variable that contains the handle, followed by a comma-separated argument list in parentheses. The syntax is

```
fhandle(arg1, arg2, ..., argN)
```

To execute the `sqr` function defined above, type

```
a = sqr(5)
a =
 25
```

Because `sqr` is a function handle, you can pass it in an argument list to other functions. The code shown here passes the `sqr` anonymous function to the MATLAB `integral` function to compute its integral from zero to one:

```
integral(sqr, 0, 1)
ans =
 0.3333
```

### **Example 3 – Using an Array of Function Handles**

This example creates a structure array of function handles `S` and then applies each handle in the array to the output of a `linspace` calculation in one operation using `structfun`:

```
S.a = @sin; S.b = @cos; S.c = @tan;
```

```
structfun(@(x)x(linspace(1,4,3)), S, 'UniformOutput', false)
ans =
 a: [0.8415 0.5985 -0.7568]
 b: [0.5403 -0.8011 -0.6536]
 c: [1.5574 -0.7470 1.1578]
```

### See Also

[str2func](#) | [func2str](#) | [functions](#) | [isa](#)

# functions

---

**Purpose** Information about function handle

**Syntax** `S = functions(funhandle)`

**Description** `S = functions(funhandle)` returns, in MATLAB structure `S`, the function name, type, filename, and other information for the function handle stored in the variable `funhandle`.

`functions` does not operate on nonscalar function handles. Passing a nonscalar function handle to `functions` results in an error.

---

**Caution** The `functions` function is provided for querying and debugging purposes. Because its behavior may change in subsequent releases, you should not rely upon it for programming purposes.

---

This table lists the standard fields of the return structure.

| Field Name            | Field Description                                                                            |
|-----------------------|----------------------------------------------------------------------------------------------|
| <code>function</code> | Function name                                                                                |
| <code>type</code>     | Function type (e.g., simple, overloaded)                                                     |
| <code>file</code>     | The file to be executed when the function handle is evaluated with a nonoverloaded data type |

## Examples

### Example 1

To obtain information on a function handle for the `poly` function, type

```
f = functions(@poly)
f =
 function: 'poly'
 type: 'simple'
 file: '$matlabroot\toolbox\matlab\polyfun\poly.m'
```



(The term `$matlabroot` used in this example stands for the file specification of the directory in which MATLAB software is installed for your system. Your output will display this file specification.)

Access individual fields of the returned structure using dot selection notation:

```
f.type
ans =
 simple
```

## Example 2

The function `get_handles` returns function handles for a local function and private function in output arguments `l` and `p` respectively:

```
function [l, p] = get_handles
l = @mylocfun;
p = @myprivatefun;
%
function mylocfun
disp 'Executing local function mylocfun'
```

Call `get_handles` to obtain the two function handles, and then pass each to the `functions` function. MATLAB returns information in a structure having the fields `function`, `type`, `file`, and `parentage`. The `file` field contains the file specification for the local or private function:

```
[floc fprv] = get_handles;

functions(floc)
ans =
 function: 'mylocfun'
 type: 'scopedfunction'
 file: 'c:\matlab\get_handles.m'
 parentage: {'mylocfun' 'get_handles'}
```

```
functions(fprv)
ans =
```

# functions

---

```
function: 'myprivatefun'
type: 'scopedfunction'
file: 'c:\matlab\private\myprivatefun.m'
parentage: {'myprivatefun'}
```

## Example 3

In this example, the function `get_handles_nested.m` contains a nested function `nestfun`. This function has a single output which is a function handle to the nested function:

```
function handle = get_handles_nested(A)
nestfun(A);
```

```
function y = nestfun(x)
y = x + 1;
end
```

```
handle = @nestfun;
end
```

Call this function to get the handle to the nested function. Use this handle as the input to `functions` to return the information shown here. Note that the `function` field of the return structure contains the names of the nested function and the function in which it is nested in the format. Also note that `functions` returns a `workspace` field containing the variables that are in context at the time you call this function by its handle:

```
fh = get_handles_nested(5);

finfo = functions(fh)
finfo =
 function: 'get_handles_nested/nestfun'
 type: 'nested'
 file: 'c:\matlab\get_handles_nested.m'
 workspace: [1x1 struct]

finfo.workspace
```

```
ans =
 handle: @get_handles_nested/nestfun
 A: 5
```

## See Also

[function\\_handle](#) | [func2str](#) | [str2func](#)

# functiontests

---

**Purpose** Create array of tests from handles to local functions

**Syntax** `tests = functiontests(f)`

**Description** `tests = functiontests(f)` creates an array of tests, `tests`, from a cell array of handles to local functions, `f`. To apply defined setup and teardown functions, include their function handles in `f`.

Local test functions must include 'test' at the beginning or end of the function name. `functiontests` must be called from within a test file.

## Input Arguments

### **f - Handles to local test functions**

cell array of function handles

Handles to local test functions, specified as a cell array. Use `f=localfunctions` in your working file to automatically generate a cell array of function handles for that file. If you want explicit test enumeration, construct `f` by listing individual functions. `f` must include any setup or teardown functions necessary for your test.

**Example:** `f = localfunctions;`

**Example:** `f = {@setup,@exampleOneTest,@teardown};`

## Examples

### **Create Test Array**

Create the file `exampleTest.m` in your MATLAB path. In the main function, create a test array. Use local functions to define setup, teardown, and two function tests. Your file should look like this.

```
function tests = exampleTest
tests = functiontests(localfunctions);
```

```
function setup(testCase)
function teardown(testCase)
function exampleOneTest(testCase)
function testExampleTwo(testCase)
```

From the command line, call the `exampleTest` function.

```
tests = exampleTest

tests =

 1x2 Test array with properties:

 Name
 Parameterization
 SharedTestFixtures
```

Access the test suite to verify the names of the two function tests.

```
tests.Name

ans =

exampleTest/exampleOneTest

ans =

exampleTest/testExampleTwo
```

## See Also

[matlab.unittest.Test](#) | [localfunctions](#) | [runtests](#)

## Related Examples

- “Write Function-Based Unit Tests”
- “Write Simple Test Case Using Functions”
- “Write Test Using Setup and Teardown Functions”

# funm

---

**Purpose** Evaluate general matrix function

**Syntax**

```
F = funm(A,fun)
F = funm(A,fun,options)
F = funm(A,fun,options,p1,p2,...)
[F,exitflag] = funm(...)
[F,exitflag,output] = funm(...)
```

**Description** `F = funm(A,fun)` evaluates the user-defined function `fun` at the square matrix argument `A`. `F = fun(x,k)` must accept a vector `x` and an integer `k`, and return a vector `f` of the same size of `x`, where `f(i)` is the `k`th derivative of the function `fun` evaluated at `x(i)`. The function represented by `fun` must have a Taylor series with an infinite radius of convergence, except for `fun = @log`, which is treated as a special case.

You can also use `funm` to evaluate the special functions listed in the following table at the matrix `A`.

| Function          | Syntax for Evaluating Function at Matrix A |
|-------------------|--------------------------------------------|
| <code>exp</code>  | <code>funm(A, @exp)</code>                 |
| <code>log</code>  | <code>funm(A, @log)</code>                 |
| <code>sin</code>  | <code>funm(A, @sin)</code>                 |
| <code>cos</code>  | <code>funm(A, @cos)</code>                 |
| <code>sinh</code> | <code>funm(A, @sinh)</code>                |
| <code>cosh</code> | <code>funm(A, @cosh)</code>                |

For matrix square roots, use `sqrtm(A)` instead. For matrix exponentials, which of `expm(A)` or `funm(A, @exp)` is the more accurate depends on the matrix `A`.

The function represented by `fun` must have a Taylor series with an infinite radius of convergence. The exception is `@log`, which is treated as a special case. “Parameterizing Functions” explains how to provide additional parameters to the function `fun`, if necessary.

$F = \text{funm}(A, \text{fun}, \text{options})$  sets the algorithm's parameters to the values in the structure options.

The following table lists the fields of options.

| Field            | Description                                                                                                 | Values                                                                                                                                                            |
|------------------|-------------------------------------------------------------------------------------------------------------|-------------------------------------------------------------------------------------------------------------------------------------------------------------------|
| options.Display  | Level of display                                                                                            | 'off' (default), 'on', 'verbose'                                                                                                                                  |
| options.TolBlk   | Tolerance for blocking Schur form                                                                           | Positive scalar. The default is 0.1.                                                                                                                              |
| options.TolTay   | Termination tolerance for evaluating the Taylor series of diagonal blocks                                   | Positive scalar. The default is eps.                                                                                                                              |
| options.MaxTerms | Maximum number of Taylor series terms                                                                       | Positive integer. The default is 250.                                                                                                                             |
| options.MaxSqrt  | When computing a logarithm, maximum number of square roots computed in inverse scaling and squaring method. | Positive integer. The default is 100.                                                                                                                             |
| options.Ord      | Specifies the ordering of the Schur form $T$ .                                                              | A vector of length <code>length(A)</code> . <code>options.Ord(i)</code> is the index of the block into which $T(i,i)$ is placed. The default is <code>[]</code> . |

$F = \text{funm}(A, \text{fun}, \text{options}, p1, p2, \dots)$  passes extra inputs  $p1, p2, \dots$  to the function.

$[F, \text{exitflag}] = \text{funm}(\dots)$  returns a scalar `exitflag` that describes the exit condition of `funm`. `exitflag` can have the following values:

- 0 — The algorithm was successful.

- 1 — One or more Taylor series evaluations did not converge, or, in the case of a logarithm, too many square roots are needed. However, the computed value of F might still be accurate.

[F,exitflag,output] = funm(...) returns a structure output with the following fields:

| Field        | Description                                                                                                                                                                                                             |
|--------------|-------------------------------------------------------------------------------------------------------------------------------------------------------------------------------------------------------------------------|
| output.terms | Vector for which output.terms(i) is the number of Taylor series terms used when evaluating the <i>i</i> th block, or, in the case of the logarithm, the number of square roots of matrices of dimension greater than 2. |
| output.ind   | Cell array for which the (i,j) block of the reordered Schur factor T is T(output.ind{i}, output.ind{j}).                                                                                                                |
| output.ord   | Ordering of the Schur form, as passed to ordschur                                                                                                                                                                       |
| output.T     | Reordered Schur form                                                                                                                                                                                                    |

If the Schur form is diagonal then output = struct('terms',ones(n,1),'ind',{1:n}).

## Examples

### Example 1

The following command computes the matrix sine of the 3-by-3 magic matrix.

```
F=funm(magic(3), @sin)
```

```
F =
```

```
-0.3850 1.0191 0.0162
 0.6179 0.2168 -0.1844
 0.4173 -0.5856 0.8185
```



**Example 2**

The statements

```
S = funm(X,@sin);
C = funm(X,@cos);
```

produce the same results to within roundoff error as

```
E = expm(i*X);
C = real(E);
S = imag(E);
```

In either case, the results satisfy  $S^2 + C^2 = I$ , where  $I = \text{eye}(\text{size}(X))$ .

**Example 3**

To compute the function  $\exp(x) + \cos(x)$  at  $A$  with one call to `funm`, use

```
F = funm(A,@fun_expcos)
```

where `fun_expcos` is the following function.

```
function f = fun_expcos(x, k)
% Return kth derivative of exp + cos at X.
 g = mod(ceil(k/2),2);
 if mod(k,2)
 f = exp(x) + sin(x)*(-1)^g;
 else
 f = exp(x) + cos(x)*(-1)^g;
 end
```

**Algorithms**

The algorithm `funm` uses is described in [1].

**References**

[1] Davies, P. I. and N. J. Higham, "A Schur-Parlett algorithm for computing matrix functions," *SIAM J. Matrix Anal. Appl.*, Vol. 25, Number 2, pp. 464-485, 2003.

[2] Golub, G. H. and C. F. Van Loan, *Matrix Computation*, Third Edition, Johns Hopkins University Press, 1996, p. 384.

[3] Moler, C. B. and C. F. Van Loan, “Nineteen Dubious Ways to Compute the Exponential of a Matrix, Twenty-Five Years Later” *SIAM Review* 20, Vol. 45, Number 1, pp. 1-47, 2003.

## See Also

`expm` | `logm` | `sqrtm` | `function_handle`

**Purpose**

Write data to binary file

**Syntax**

```
fwrite(fileID, A)
fwrite(fileID, A, precision)
fwrite(fileID, A, precision, skip)
fwrite(fileID, A, precision, skip, machineformat)
count = fwrite(...)
```

**Description**

`fwrite(fileID, A)` writes the elements of array *A* to a binary file in column order.

`fwrite(fileID, A, precision)` translates the values of *A* according to the form and size described by the *precision*.

`fwrite(fileID, A, precision, skip)` skips *skip* bytes before writing each value. If *precision* is *bitn* or *ubitn*, specify *skip* in bits.

`fwrite(fileID, A, precision, skip, machineformat)` writes data with the specified *machineformat*. The *skip* parameter is optional.

`count = fwrite(...)` returns the number of elements of *A* that `fwrite` successfully writes to the file.

**Input Arguments****fileID**

File identifier, specified as one of the following:

- A file identifier obtained from `fopen`.
- 1 for standard output (the screen).
- 2 for standard error.

**A**

Numeric or character array.

**precision**

String in single quotation marks that controls the form and size of the output. The following table shows possible values for *precision*.

| Value Type         | Precision     | Bits (Bytes)       |
|--------------------|---------------|--------------------|
| Integers, unsigned | uint          | 32 (4)             |
|                    | uint8         | 8 (1)              |
|                    | uint16        | 16 (2)             |
|                    | uint32        | 32 (4)             |
|                    | uint64        | 64 (8)             |
|                    | uchar         | 8 (1)              |
|                    | unsigned char | 8 (1)              |
|                    | ushort        | 16 (2)             |
|                    | ulong         | 32 (4)             |
|                    | ubit <i>n</i> | $1 \leq n \leq 64$ |
| Integers, signed   | int           | 32 (4)             |
|                    | int8          | 8 (1)              |
|                    | int16         | 16 (2)             |
|                    | int32         | 32 (4)             |
|                    | int64         | 64 (8)             |
|                    | integer*1     | 8 (1)              |
|                    | integer*2     | 16 (2)             |
|                    | integer*4     | 32 (4)             |
|                    | integer*8     | 64 (8)             |
|                    | schar         | 8 (1)              |
|                    | signed char   | 8 (1)              |
|                    | short         | 16 (2)             |
|                    | long          | 32 (4)             |
|                    | bit <i>n</i>  | $1 \leq n \leq 64$ |

| Value Type             | Precision | Bits (Bytes)                                                                                    |
|------------------------|-----------|-------------------------------------------------------------------------------------------------|
| Floating-point numbers | single    | 32 (4)                                                                                          |
|                        | double    | 64 (8)                                                                                          |
|                        | float     | 32 (4)                                                                                          |
|                        | float32   | 32 (4)                                                                                          |
|                        | float64   | 64 (8)                                                                                          |
|                        | real*4    | 32 (4)                                                                                          |
|                        | real*8    | 64 (8)                                                                                          |
| Characters             | char*1    | 8 (1)                                                                                           |
|                        | char      | Depends on the encoding scheme associated with the file. Set encoding with <code>fopen</code> . |

If you specify a precision of `bitn` or `ubitn`, and a value is out of range, `fwrite` sets all bits for that value.

**Default:** `uint8`

### **skip**

Number of bytes to skip before writing each value. If you specify a *precision* of `bitn` or `ubitn`, specify *skip* in bits. Use this parameter to insert data into noncontiguous fields in fixed-length records.

**Default:** 0

### **machineformat**

String that specifies the order for writing bytes within the file. For `bitn` and `ubitn` precisions, specifies the order for writing bits within a byte.

# fwrite

---

|                      |                                               |
|----------------------|-----------------------------------------------|
| 'n' or 'native'      | Your system byte ordering (default)           |
| 'b' or 'ieee-be'     | Big-endian ordering                           |
| 'l' or 'ieee-le'     | Little-endian ordering                        |
| 's' or 'ieee-be.l64' | Big-endian ordering, 64-bit long data type    |
| 'a' or 'ieee-le.l64' | Little-endian ordering, 64-bit long data type |

By default, all currently supported platforms use little-endian ordering for new files. Existing binary files can use either big-endian or little-endian ordering.

## Examples

Create a 100-byte binary file containing the 25 elements of the 5-by-5 magic square, stored as 4-byte integers:

```
fid = fopen('magic5.bin', 'w');
fwrite(fid, magic(5), 'integer*4');
fclose(fid);
```

## See Also

[fclose](#) | [ferror](#) | [fopen](#) | [fprintf](#) | [fscanf](#) | [fread](#) | [fseek](#) | [ftell](#)

## How To

- “Overwriting or Appending to an Existing File”
- “Creating a File for Use on a Different System”
- “Writing and Reading Complex Numbers”

**Purpose** Write binary data to device

**Syntax**

```
fwrite(obj,A)
fwrite(obj,A,'precision')
fwrite(obj,A,'mode')
fwrite(obj,A,'precision','mode')
```

**Description**

`fwrite(obj,A)` writes the binary data *A* to the device connected to the serial port object, *obj*.

`fwrite(obj,A,'precision')` writes binary data with precision specified by *precision*.

*precision* controls the number of bits written for each value and the interpretation of those bits as integer, floating-point, or character values. If *precision* is not specified, `uchar` (an 8-bit unsigned character) is used. The supported values for *precision* are listed below in Tips.

`fwrite(obj,A,'mode')` writes binary data with command line access specified by *mode*. If *mode* is `sync`, *A* is written synchronously and the command line is blocked. If *mode* is `async`, *A* is written asynchronously and the command line is not blocked. If *mode* is not specified, the write operation is synchronous.

`fwrite(obj,A,'precision','mode')` writes binary data with precision specified by *precision* and command line access specified by *mode*.

**Tips**

Before you can write data to the device, it must be connected to *obj* with the `fopen` function. A connected serial port object has a `Status` property value of `open`. An error is returned if you attempt to perform a write operation while *obj* is not connected to the device.

The `ValuesSent` property value is increased by the number of values written each time `fwrite` is issued.

An error occurs if the output buffer cannot hold all the data to be written. You can specify the size of the output buffer with the `OutputBufferSize` property.

## fwrite (serial)

---

`fwrite` returns an error message if you set the `FlowControl` property to `hardware` on a serial object, and a hardware connection is not detected. This occurs if a device is not connected, or a connected device is not asserting that it is ready to receive data. Check you remote device's status and flow control settings to see if hardware flow control is causing errors in MATLAB.

---

**Note** If you want to check to see if the device is asserting that it is ready to receive data, set the `FlowControl` to `none`. Once you connect to the device check the `PinStatus` structure for `ClearToSend`. If `ClearToSend` is off, there is a problem on the remote device side. If `ClearToSend` is on, there is a hardware `FlowControl` device prepared to receive data and you can execute `fwrite`.

---

### Synchronous Versus Asynchronous Write Operations

By default, data is written to the device synchronously and the command line is blocked until the operation completes. You can perform an asynchronous write by configuring the `mode` input argument to be `async`. For asynchronous writes:

- The `BytesToOutput` property value is continuously updated to reflect the number of bytes in the output buffer.
- The callback function specified for the `OutputEmptyFcn` property is executed when the output buffer is empty.

You can determine whether an asynchronous write operation is in progress with the `TransferStatus` property.

Synchronous and asynchronous write operations are discussed in more detail in [Writing Data](#).

### Rules for Completing a Write Operation with fwrite

A binary write operation using `fwrite` completes when:

- The specified data is written.
- The time specified by the `Timeout` property passes.



---

**Note** The Terminator property is not used with binary write operations.

---

## Supported Precisions

The supported values for *precision* are listed below.

| Data Type | Precision | Interpretation                     |
|-----------|-----------|------------------------------------|
| Character | uchar     | 8-bit unsigned character           |
|           | schar     | 8-bit signed character             |
|           | char      | 8-bit signed or unsigned character |
| Integer   | int8      | 8-bit integer                      |
|           | int16     | 16-bit integer                     |
|           | int32     | 32-bit integer                     |
|           | uint8     | 8-bit unsigned integer             |
|           | uint16    | 16-bit unsigned integer            |
|           | uint32    | 32-bit unsigned integer            |
|           | short     | 16-bit integer                     |
|           | int       | 32-bit integer                     |
|           | long      | 32- or 64-bit integer              |
|           | ushort    | 16-bit unsigned integer            |
|           | uint      | 32-bit unsigned integer            |
|           | ulong     | 32- or 64-bit unsigned integer     |

## fwrite (serial)

---

| Data Type      | Precision | Interpretation        |
|----------------|-----------|-----------------------|
| Floating-point | single    | 32-bit floating point |
|                | float32   | 32-bit floating point |
|                | float     | 32-bit floating point |
|                | double    | 64-bit floating point |
|                | float64   | 64-bit floating point |

### See Also

[fopen](#) | [fprintf](#) | [BytesToOutput](#) | [OutputBufferSize](#) | [OutputEmptyFcn](#) | [Status](#) | [Timeout](#) | [TransferStatus](#) | [ValuesSent](#)

**Purpose**

Root of nonlinear function

**Syntax**

```
x = fzero(fun,x0)
x = fzero(fun,x0,options)
```

```
x = fzero(problem)
```

```
[x,fval,exitflag,output] = fzero(__)
```

**Description**

`x = fzero(fun,x0)` tries to find a point  $x$  where  $\text{fun}(x) = 0$ . This solution is where  $\text{fun}(x)$  changes sign—`fzero` cannot find a root of a function such as  $x^2$ .

`x = fzero(fun,x0,options)` uses options to modify the solution process.

`x = fzero(problem)` solves a root-finding problem specified by `problem`.

`[x,fval,exitflag,output] = fzero( __ )` returns  $\text{fun}(x)$  in the `fval` output, `exitflag` encoding the reason `fzero` stopped, and an output structure containing information on the solution process.

**Input Arguments****fun - Function to solve**

function handle

Function to solve, specified as a handle to a scalar-valued function. `fun` accepts a scalar  $x$  and returns a scalar  $\text{fun}(x)$ .

`fzero` solves  $\text{fun}(x) = 0$ . To solve an equation  $\text{fun}(x) = c(x)$ , instead solve  $\text{fun2}(x) = \text{fun}(x) - c(x) = 0$ .

To include extra parameters in your function, see the example “Root of Function with Extra Parameter” on page 1-2367 and the section “Parameterizing Functions”.

**Example:** @sin

**Example:** @myFunction

**Example:** @(x)(x-a)^5 - 3\*x + a - 1

## Data Types

function\_handle

## **x0 - Initial value**

scalar | 2-element vector

Initial value, specified as a real scalar or a 2-element real vector.

- Scalar — `fzero` begins at `x0` and tries to locate a point `x1` where `fun(x1)` has the opposite sign of `fun(x0)`. Then `fzero` iteratively shrinks the interval where `fun` changes sign to reach a solution.
- 2-element vector — `fzero` checks that `fun(x0(1))` and `fun(x0(2))` have opposite signs, and errors if they do not. It then iteratively shrinks the interval where `fun` changes sign to reach a solution. An interval `x0` must be finite; it cannot contain  $\pm\text{Inf}$ .

---

**Tip** Calling `fzero` with an interval (`x0` with two elements) is often faster than calling it with a scalar `x0`.

---

**Example:** 3

**Example:** [2,17]

## Data Types

double

## **options - Options for solution process**

structure, typically created using `optimset`

Options for solution process, specified as a structure. Create or modify the `options` structure using `optimset`. `fzero` uses these `options` structure fields.

|             |                                                                                                                                                                                                                                                                                                                                                                                                                                            |
|-------------|--------------------------------------------------------------------------------------------------------------------------------------------------------------------------------------------------------------------------------------------------------------------------------------------------------------------------------------------------------------------------------------------------------------------------------------------|
| Display     | <p>Level of display:</p> <ul style="list-style-type: none"> <li>• 'off' displays no output.</li> <li>• 'iter' displays output at each iteration.</li> <li>• 'final' displays just the final output.</li> <li>• 'notify' (default) displays output only if the function does not converge.</li> </ul>                                                                                                                                       |
| FunValCheck | <p>Check whether objective function values are valid.</p> <ul style="list-style-type: none"> <li>• 'on' displays an error when the objective function returns a value that is complex, Inf, or NaN.</li> <li>• The default, 'off', displays no error.</li> </ul>                                                                                                                                                                           |
| OutputFcn   | <p>Specify one or more user-defined functions that an optimization function calls at each iteration, either as a function handle or as a cell array of function handles. The default is none ( []). See “Output Functions”.</p>                                                                                                                                                                                                            |
| PlotFcns    | <p>Plot various measures of progress while the algorithm executes. Select from predefined plots or write your own. Pass a function handle or a cell array of function handles. The default is none ( []).</p> <ul style="list-style-type: none"> <li>• @optimplotx plots the current point.</li> <li>• @optimplotfval plots the function value.</li> </ul> <p>For information on writing a custom plot function, see “Plot Functions”.</p> |
| TolX        | <p>Termination tolerance on x, a positive scalar. The default is eps, 2.2204e-16.</p>                                                                                                                                                                                                                                                                                                                                                      |

**Example:** `options = optimset('FunValCheck','on')`

### Data Types

struct

## **problem - Root-finding problem**

structure

Root-finding problem, specified as a structure with all of the following fields.

|                        |                                                                    |
|------------------------|--------------------------------------------------------------------|
| <code>objective</code> | Objective function                                                 |
| <code>x0</code>        | Initial point for <code>x</code> , real scalar or 2-element vector |
| <code>solver</code>    | 'fzero'                                                            |
| <code>options</code>   | Options structure, typically created using <code>optimset</code>   |

For an example, see “Solve Problem Structure” on page 1-2368.

## **Data Types**

struct

## **Output Arguments**

### **x - Location of root or sign change**

real scalar

Location of root or sign change, returned as a scalar.

### **fval - Function value at x**

real scalar

Function value at `x`, returned as a scalar.

### **exitflag - Integer encoding the exit condition**

integer

Integer encoding the exit condition, meaning the reason `fsolve` stopped its iterations.

|    |                                                                   |
|----|-------------------------------------------------------------------|
| 1  | Function converged to a solution <code>x</code> .                 |
| -1 | Algorithm was terminated by the output function or plot function. |

- 3 NaN or Inf function value was encountered while searching for an interval containing a sign change.
- 4 Complex function value was encountered while searching for an interval containing a sign change.
- 5 Algorithm might have converged to a singular point.
- 6 fzero did not detect a sign change.

### output - Information about root-finding process

structure

Information about root-finding process, returned as a structure. The fields of the structure are:

|            |                                                                  |
|------------|------------------------------------------------------------------|
| interval   | Number of iterations taken to find an interval containing a root |
| iterations | Number of zero-finding iterations                                |
| funcCount  | Number of function evaluations                                   |
| algorithm  | 'bisection, interpolation'                                       |
| message    | Exit message                                                     |

## Examples

### Root Starting From One Point

Calculate  $\pi$  by finding the zero of the sine function near 3.

```
fun = @sin; % function
x0 = 3; % initial point
x = fzero(fun,x0)
```

```
x =
 3.1416
```

### Root Starting From an Interval

Find the zero of cosine between 1 and 2.

```
fun = @cos; % function
x0 = [1 2]; % initial interval
x = fzero(fun,x0)
```

```
x =
 1.5708
```

Note that  $\cos(1)$  and  $\cos(2)$  differ in sign.

## Root of a Function Defined by a File

Find a zero of the function  $f(x) = x^3 - 2x - 5$ .

First, write a file called `f.m`.

```
function y = f(x)
y = x.^3 - 2*x - 5;
```

Save `f.m` on your MATLAB path.

Find the zero of  $f(x)$  near 2.

```
fun = @f; % function
x0 = 2; % initial point
z = fzero(fun,x0)
```

```
z =
 2.0946
```

Since  $f(x)$  is a polynomial, you can find the same real zero, and a complex conjugate pair of zeros, using the `roots` command.

```
roots([1 0 -2 -5])
```

```
ans =
 2.0946
 -1.0473 + 1.1359i
 -1.0473 - 1.1359i
```



### Root of Function with Extra Parameter

Find the root of a function that has an extra parameter.

```
myfun = @(x,c) cos(c*x); % parameterized function
c = 2; % parameter
fun = @(x) myfun(x,c); % function of x alone
x = fzero(fun,0.1)
```

```
x =
```

```
0.7854
```

### Nondefault Options

Plot the solution process by setting some plot functions.

Define the function and initial point.

```
fun = @(x)sin(cosh(x));
x0 = 1;
```

Examine the solution process by setting options that include plot functions.

```
options = optimset('PlotFcns',{@optimplotx,@optimplotfval});
```

Run fzero including the options.

```
x = fzero(fun,x0,options)
```

```
x =
```

```
1.8115
```

# fzero

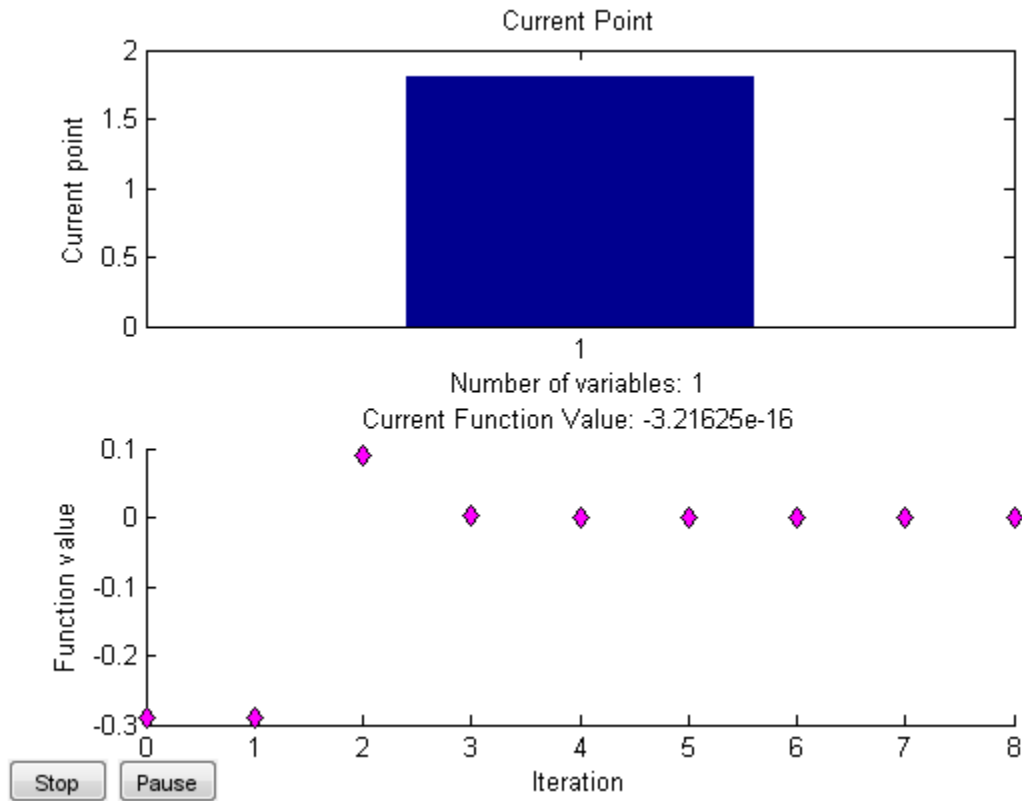

## Solve Problem Structure

Solve a problem that is defined by a problem structure.

Define a structure that encodes a root-finding problem.

```
problem.objective = @(x)sin(cosh(x));
problem.x0 = 1;
problem.solver = 'fzero'; % a required part of the structure
problem.options = optimset(@fzero); % default options
```

Solve the problem.

```
x = fzero(problem)
```

```
x =
```

```
1.8115
```

### More Information from Solution

Find the point where  $\exp(-\exp(-x)) = x$ , and display information about the solution process.

```
fun = @(x) exp(-exp(-x)) - x; % function
x0 = [0 1]; % initial interval
options = optimset('Display','iter'); % show iterations
[x fval exitflag output] = fzero(fun,x0,options)
```

| Func-count | x        | f(x)         | Procedure     |
|------------|----------|--------------|---------------|
| 2          | 1        | -0.307799    | initial       |
| 3          | 0.544459 | 0.0153522    | interpolation |
| 4          | 0.566101 | 0.00070708   | interpolation |
| 5          | 0.567143 | -1.40255e-08 | interpolation |
| 6          | 0.567143 | 1.50013e-12  | interpolation |
| 7          | 0.567143 | 0            | interpolation |

```
Zero found in the interval [0, 1]
```

```
x =
```

```
0.5671
```

```
fval =
```

```
0
```

```
exitflag =
```

```
1
```

```
output =
```

```
intervaliterations: 0
```

```
iterations: 5
```

```
funcCount: 7
```

```
algorithm: 'bisection, interpolation'
```

```
message: 'Zero found in the interval [0, 1]'
```

`fval = 0` means  $\text{fun}(x) = 0$ , as desired.

## Algorithms

The `fzero` command is a function file. The algorithm, created by T. Dekker, uses a combination of bisection, secant, and inverse quadratic interpolation methods. An Algol 60 version, with some improvements, is given in [1]. A Fortran version, upon which `fzero` is based, is in [2].

## References

[1] Brent, R., *Algorithms for Minimization Without Derivatives*, Prentice-Hall, 1973.

[2] Forsythe, G. E., M. A. Malcolm, and C. B. Moler, *Computer Methods for Mathematical Computations*, Prentice-Hall, 1976.

## See Also

`fminbnd` | `optimset` | `roots`

## Related Examples

- “Roots of Scalar Functions”
- “Parameterizing Functions”

**Purpose**

Test matrices

**Syntax**

```
[A,B,C,...] = gallery(matname,P1,P2,...)
[A,B,C,...] = gallery(matname,P1,P2,...,classname)
gallery(3)
gallery(5)
```

**Description**

[A,B,C,...] = gallery(matname,P1,P2,...) returns the test matrices specified by the quoted string matname. The matname input is the name of a matrix family selected from the table below. P1,P2,... are input parameters required by the individual matrix family. The number of optional parameters P1,P2,... used in the calling syntax varies from matrix to matrix. The exact calling syntaxes are detailed in the individual matrix descriptions below.

[A,B,C,...] = gallery(matname,P1,P2,...,classname) produces a matrix of class classname. The classname input is a quoted string that must be either 'single' or 'double' (unless matname is 'integerdata', in which case 'int8', 'int16', 'int32', 'uint8', 'uint16', and 'uint32' are also allowed). If classname is not specified, then the class of the matrix is determined from those arguments among P1,P2,... that do not specify dimensions or select an option. If any of these arguments is of class single then the matrix is single; otherwise the matrix is double.

gallery(3) is a badly conditioned 3-by-3 matrix and gallery(5) is an interesting eigenvalue problem.

The gallery holds over fifty different test matrix functions useful for testing algorithms and other purposes.

- binomial
- cauchy
- chebspec
- chebvand
- chow

- `circul`
- `clement`
- `compar`
- `condex`
- `cycol`
- `dorr`
- `dramadah`
- `fiedler`
- `forsythe`
- `frank`
- `gearmat`
- `gcdmat`
- `grcar`
- `hanowa`
- `house`
- `integerdata`
- `invhess`
- `invol`
- `ipjfact`
- `jordbloc`
- `kahan`
- `kms`
- `krylov`
- `lauchli`
- `lehmer`

- leslie
- lesp
- lotkin
- minij
- moler
- neumann
- normaldata
- orthog
- parter
- pei
- poisson
- prolate
- randcolu
- randcorr
- randhess
- randjorth
- rando
- randsvd
- redheff
- riemann
- ris
- sampling
- smoke
- toeppd
- tridiag

- triw
- uniformdata
- wathen
- wilk

## **binomial – Multiple of involutory matrix**

$A = \text{gallery}('binomial', n)$  returns an  $n$ -by- $n$  matrix, with integer entries such that  $A^2 = 2^{(n-1)} \cdot \text{eye}(n)$ .

Thus,  $B = A \cdot 2^{-(n-1)/2}$  is involutory, that is,  $B^2 = \text{eye}(n)$ .

## **cauchy – Cauchy matrix**

$C = \text{gallery}('cauchy', x, y)$  returns an  $n$ -by- $n$  matrix,  $C(i, j) = 1/(x(i)+y(j))$ . Arguments  $x$  and  $y$  are vectors of length  $n$ . If you pass in scalars for  $x$  and  $y$ , they are interpreted as vectors  $1:x$  and  $1:y$ .

$C = \text{gallery}('cauchy', x)$  returns the same as above with  $y = x$ . That is, the command returns  $C(i, j) = 1/(x(i)+x(j))$ .

Explicit formulas are known for the inverse and determinant of a Cauchy matrix. The determinant  $\det(C)$  is nonzero if  $x$  and  $y$  both have distinct elements.  $C$  is totally positive if  $0 < x(1) < \dots < x(n)$  and  $0 < y(1) < \dots < y(n)$ .

## **chebspec – Chebyshev spectral differentiation matrix**

$C = \text{gallery}('chebspec', n, \text{switch})$  returns a Chebyshev spectral differentiation matrix of order  $n$ . Argument  $\text{switch}$  is a variable that determines the character of the output matrix. By default,  $\text{switch} = 0$ .

For  $\text{switch} = 0$  (“no boundary conditions”),  $C$  is nilpotent ( $C^n = 0$ ) and has the null vector  $\text{ones}(n, 1)$ . The matrix  $C$  is similar to a Jordan block of size  $n$  with eigenvalue zero.

For  $\text{switch} = 1$ ,  $C$  is nonsingular and well-conditioned, and its eigenvalues have negative real parts.



The eigenvector matrix of the Chebyshev spectral differentiation matrix is ill-conditioned.

### **chebvand – Vandermonde-like matrix for the Chebyshev polynomials**

`C = gallery('chebvand',p)` produces the (primal) Chebyshev Vandermonde matrix based on the vector of points `p`, which define where the Chebyshev polynomial is calculated.

`C = gallery('chebvand',m,p)` where `m` is scalar, produces a rectangular version of the above, with `m` rows.

If `p` is a vector, then  $C(i,j) = T_{i-1}(p(j))$  where  $T_{i-1}$  is the Chebyshev polynomial of degree  $i-1$ . If `p` is a scalar, then `p` equally spaced points on the interval `[0,1]` are used to calculate `C`.

### **chow – Singular Toeplitz lower Hessenberg matrix**

`A = gallery('chow',n,alpha,delta)` returns `A` such that  $A = H(\alpha) + \delta \cdot \text{eye}(n)$ , where  $H_{i,j}(\alpha) = \alpha^{(i-j+1)}$  and argument `n` is the order of the Chow matrix. Default value for scalars `alpha` and `delta` are 1 and 0, respectively.

$H(\alpha)$  has  $p = \text{floor}(n/2)$  eigenvalues that are equal to zero. The rest of the eigenvalues are equal to  $4 \cdot \alpha \cdot \cos(k \cdot \pi / (n+2))^2$ ,  $k=1:n-p$ .

### **circul – Circulant matrix**

`C = gallery('circul',v)` returns the circulant matrix whose first row is the vector `v`.

A circulant matrix has the property that each row is obtained from the previous one by cyclically permuting the entries one step forward. It is a special Toeplitz matrix in which the diagonals “wrap around.”

If `v` is a scalar, then `C = gallery('circul',1:v)`.

The eigensystem of `C` (`n`-by-`n`) is known explicitly: If `t` is an `n`th root of unity, then the inner product of `v` and  $w = [1 \ t \ t^2 \ \dots \ t^{(n-1)}]$  is an eigenvalue of `C` and  $w(n:-1:1)$  is an eigenvector.

## **clement – Tridiagonal matrix with zero diagonal entries**

`A = gallery('clement',n,k)` returns an  $n$ -by- $n$  tridiagonal matrix with zeros on its main diagonal and known eigenvalues. It is singular if  $n$  is odd. About 64 percent of the entries of the inverse are zero. The eigenvalues include plus and minus the numbers  $n-1, n-3, n-5, \dots, (1 \text{ or } 0)$ .

For  $k=0$  (the default),  $A$  is nonsymmetric. For  $k=1$ ,  $A$  is symmetric.

`gallery('clement',n,1)` is diagonally similar to `gallery('clement',n)`.

For odd  $N = 2*M+1$ ,  $M+1$  of the singular values are the integers  $\sqrt{(2*M+1)^2 - (2*K+1).^2}$ ,  $K = 0:M$ .

---

**Note** Similar properties hold for `gallery('tridiag',x,y,z)` where  $y = \text{zeros}(n,1)$ . The eigenvalues still come in plus/minus pairs but they are not known explicitly.

---

## **compar – Comparison matrices**

`A = gallery('compar',A,1)` returns  $A$  with each diagonal element replaced by its absolute value, and each off-diagonal element replaced by minus the absolute value of the largest element in absolute value in its row. However, if  $A$  is triangular `compar(A,1)` is too.

`gallery('compar',A)` is  $\text{diag}(B) - \text{tril}(B,-1) - \text{triu}(B,1)$ , where  $B = \text{abs}(A)$ . `compar(A)` is often denoted by  $M(A)$  in the literature.

`gallery('compar',A,0)` is the same as `gallery('compar',A)`.

## **condex – Counter-examples to matrix condition number estimators**

`A = gallery('condex',n,k,theta)` returns a “counter-example” matrix to a condition estimator. It has order  $n$  and scalar parameter  $\theta$  (default 100).

The matrix, its natural size, and the estimator to which it applies are specified by  $k$ :

|         |            |                                                                                       |
|---------|------------|---------------------------------------------------------------------------------------|
| $k = 1$ | 4-by-4     | LINPACK                                                                               |
| $k = 2$ | 3-by-3     | LINPACK                                                                               |
| $k = 3$ | arbitrary  | LINPACK (rcond) (independent of $\theta$ )                                            |
| $k = 4$ | $n \geq 4$ | LAPACK (RCOND) (default). It is the inverse of this matrix that is a counter-example. |

If  $n$  is not equal to the natural size of the matrix, then the matrix is padded out with an identity matrix to order  $n$ .

### **cycol – Matrix whose columns repeat cyclically**

$A = \text{gallery}('cycol', [m \ n], k)$  returns an  $m$ -by- $n$  matrix with cyclically repeating columns, where one “cycle” consists of  $\text{randn}(m, k)$ . Thus, the rank of matrix  $A$  cannot exceed  $k$ , and  $k$  must be a scalar.

Argument  $k$  defaults to  $\text{round}(n/4)$ , and need not evenly divide  $n$ .

$A = \text{gallery}('cycol', n, k)$ , where  $n$  is a scalar, is the same as  $\text{gallery}('cycol', [n \ n], k)$ .

### **dorr – Diagonally dominant, ill-conditioned, tridiagonal matrix**

$[c, d, e] = \text{gallery}('dorr', n, \theta)$  returns the vectors defining an  $n$ -by- $n$ , row diagonally dominant, tridiagonal matrix that is ill-conditioned for small nonnegative values of  $\theta$ . The default value of  $\theta$  is 0.01. The Dorr matrix itself is the same as  $\text{gallery}('tridiag', c, d, e)$ .

$A = \text{gallery}('dorr', n, \theta)$  returns the matrix itself, rather than the defining vectors.

## **dramadah – Matrix of zeros and ones whose inverse has large integer entries**

`A = gallery('dramadah',n,k)` returns an  $n$ -by- $n$  matrix of 0's and 1's for which  $\mu(A) = \text{norm}(\text{inv}(A), 'fro')$  is relatively large, although not necessarily maximal. An anti-Hadamard matrix  $A$  is a matrix with elements 0 or 1 for which  $\mu(A)$  is maximal.

$n$  and  $k$  must both be scalars. Argument  $k$  determines the character of the output matrix:

- $k = 1$       Default.  $A$  is Toeplitz, with  $\text{abs}(\det(A)) = 1$ , and  $\mu(A) > c(1.75)^n$ , where  $c$  is a constant. The inverse of  $A$  has integer entries.
- $k = 2$        $A$  is upper triangular and Toeplitz. The inverse of  $A$  has integer entries.
- $k = 3$        $A$  has maximal determinant among lower Hessenberg  $(0,1)$  matrices.  $\det(A) =$  the  $n$ th Fibonacci number.  $A$  is Toeplitz. The eigenvalues have an interesting distribution in the complex plane.

## **fiedler – Symmetric matrix**

`A = gallery('fiedler',c)`, where  $c$  is a length  $n$  vector, returns the  $n$ -by- $n$  symmetric matrix with elements  $\text{abs}(n(i) - n(j))$ . For scalar  $c$ , `A = gallery('fiedler',1:c)`.

Matrix  $A$  has a dominant positive eigenvalue and all the other eigenvalues are negative.

Explicit formulas for  $\text{inv}(A)$  and  $\det(A)$  are given in [Todd, J., *Basic Numerical Mathematics*, Vol. 2: Numerical Algebra, Birkhauser, Basel, and Academic Press, New York, 1977, p. 159] and attributed to Fiedler. These indicate that  $\text{inv}(A)$  is tridiagonal except for nonzero  $(1,n)$  and  $(n,1)$  elements.

## **forsythe – Perturbed Jordan block**

`A = gallery('forsythe',n,alpha,lambda)` returns the  $n$ -by- $n$  matrix equal to the Jordan block with eigenvalue  $\lambda$ , excepting that

$A(n,1) = \alpha$ . The default values of scalars  $\alpha$  and  $\lambda$  are  $\sqrt{\text{eps}}$  and 0, respectively.

The characteristic polynomial of  $A$  is given by:

$$\det(A-tI) = (\lambda-t)^N - \alpha*(-1)^n.$$

### **frank – Matrix with ill-conditioned eigenvalues**

$F = \text{gallery}('frank', n, k)$  returns the Frank matrix of order  $n$ . It is upper Hessenberg with determinant 1. If  $k = 1$ , the elements are reflected about the anti-diagonal  $(1, n) \text{ — } (n, 1)$ . The eigenvalues of  $F$  may be obtained in terms of the zeros of the Hermite polynomials. They are positive and occur in reciprocal pairs; thus if  $n$  is odd, 1 is an eigenvalue.  $F$  has  $\text{floor}(n/2)$  ill-conditioned eigenvalues — the smaller ones.

### **gcdmat – Greatest common divisor matrix**

$A = \text{gallery}('gcdmat', n)$  returns the  $n$ -by- $n$  matrix with  $(i, j)$  entry  $\text{gcd}(i, j)$ . Matrix  $A$  is symmetric positive definite, and  $A.^r$  is symmetric positive semidefinite for all nonnegative  $r$ .

### **gearmat – Gear matrix**

$A = \text{gallery}('gearmat', n, i, j)$  returns the  $n$ -by- $n$  matrix with ones on the sub- and super-diagonals,  $\text{sign}(i)$  in the  $(1, \text{abs}(i))$  position,  $\text{sign}(j)$  in the  $(n, n+1-\text{abs}(j))$  position, and zeros everywhere else. Arguments  $i$  and  $j$  default to  $n$  and  $-n$ , respectively.

Matrix  $A$  is singular, can have double and triple eigenvalues, and can be defective.

All eigenvalues are of the form  $2*\cos(a)$  and the eigenvectors are of the form  $[\sin(w+a), \sin(w+2*a), \dots, \sin(w+n*a)]$ , where  $a$  and  $w$  are given in Gear, C. W., “A Simple Set of Test Matrices for Eigenvalue Programs,” *Math. Comp.*, Vol. 23 (1969), pp. 119-125.

### **grcar – Toeplitz matrix with sensitive eigenvalues**

$A = \text{gallery}('grcar', n, k)$  returns an  $n$ -by- $n$  Toeplitz matrix with  $-1$ s on the subdiagonal,  $1$ s on the diagonal, and  $k$  superdiagonals of  $1$ s. The default is  $k = 3$ . The eigenvalues are sensitive.

## hanowa – Matrix whose eigenvalues lie on a vertical line in the complex plane

`A = gallery('hanowa',n,d)` returns an  $n$ -by- $n$  block 2-by-2 matrix of the form:

```
[d*eye(m) -diag(1:m)
diag(1:m) d*eye(m)]
```

Argument  $n$  is an even integer  $n=2*m$ . Matrix  $A$  has complex eigenvalues of the form  $d \pm k*i$ , for  $1 \leq k \leq m$ . The default value of  $d$  is  $-1$ .

## house – Householder matrix

`[v,beta,s] = gallery('house',x,k)` takes  $x$ , an  $n$ -element column vector, and returns  $V$  and  $\beta$  such that  $H*x = s*e1$ . In this expression,  $e1$  is the first column of  $\text{eye}(n)$ ,  $\text{abs}(s) = \text{norm}(x)$ , and  $H = \text{eye}(n) - \beta*v*v'$  is a Householder matrix.

$k$  determines the sign of  $s$ :

|         |                                                 |
|---------|-------------------------------------------------|
| $k = 0$ | $\text{sign}(s) = -\text{sign}(x(1))$ (default) |
| $k = 1$ | $\text{sign}(s) = \text{sign}(x(1))$            |
| $k = 2$ | $\text{sign}(s) = 1$ ( $x$ must be real)        |

If  $x$  is complex, then  $\text{sign}(x) = x./\text{abs}(x)$  when  $x$  is nonzero.

If  $x = 0$ , or if  $x = \alpha*e1$  ( $\alpha \geq 0$ ) and either  $k = 1$  or  $k = 2$ , then  $V = 0$ ,  $\beta = 1$ , and  $s = x(1)$ . In this case,  $H$  is the identity matrix, which is not strictly a Householder matrix.

-----  
`[v, beta] = gallery('house',x)` takes  $x$ , a scalar or  $n$ -element column vector, and returns  $v$  and  $\beta$  such that  $\text{eye}(n,n) - \beta*v*v'$  is a Householder matrix. A Householder matrix  $H$  satisfies the relationship

$$H*x = -\text{sign}(x(1))*\text{norm}(x)*e1$$

where  $e_1$  is the first column of  $\text{eye}(n,n)$ . Note that if  $x$  is complex, then  $\text{sign}(x) = \exp(i \cdot \arg(x))$  (which equals  $x./\text{abs}(x)$  when  $x$  is nonzero).

If  $x = 0$ , then  $v = 0$  and  $\text{beta} = 1$ .

### **integerdata – Array of arbitrary data from uniform distribution on specified range of integers**

`A = gallery('integerdata',imax,[m,n,...],j)` returns an  $m$ -by- $n$ -by-... array  $A$  whose values are a sample from the uniform distribution on the integers  $1:\text{imax}$ .  $j$  must be an integer value in the interval  $[0, 2^{32}-1]$ . Calling `gallery('integerdata', ...)` with different values of  $J$  will return different arrays. Repeated calls to `gallery('integerdata', ...)` with the same  $\text{imax}$ , size vector and  $j$  inputs will always return the same array.

In any call to `gallery('integerdata', ...)` you can substitute individual inputs  $m,n,\dots$  for the size vector input `[m,n,...]`. For example, `gallery('integerdata',7,[1,2,3,4],5)` is equivalent to `gallery('integerdata',7,1,2,3,4,5)`.

`A = gallery('integerdata',[imin imax],[m,n,...],j)` returns an  $m$ -by- $n$ -by-... array  $A$  whose values are a sample from the uniform distribution on the integers  $\text{imin}:\text{imax}$ .

`[A,B,...] = gallery('integerdata',[imin imax],[m,n,...],j)` returns multiple  $m$ -by- $n$ -by-... arrays  $A, B, \dots$ , containing different values.

`A = gallery('integerdata',[imin imax],[m,n,...],j,classname)` produces an array of class `classname`. `classname` must be `'uint8'`, `'uint16'`, `'uint32'`, `'int8'`, `'int16'`, `'int32'`, `'single'` or `'double'`.

### **invhess – Inverse of an upper Hessenberg matrix**

`A = gallery('invhess',x,y)`, where  $x$  is a length  $n$  vector and  $y$  is a length  $n-1$  vector, returns the matrix whose lower triangle agrees with that of  $\text{ones}(n,1) \cdot x'$  and whose strict upper triangle agrees with that of  $[1 \ y] \cdot \text{ones}(1,n)$ .

The matrix is nonsingular if  $x(1) \neq 0$  and  $x(i+1) \neq y(i)$  for all  $i$ , and its inverse is an upper Hessenberg matrix. Argument  $y$  defaults to  $-x(1:n-1)$ .

If  $x$  is a scalar, `invhess(x)` is the same as `invhess(1:x)`.

## **invol – Involutory matrix**

`A = gallery('invol',n)` returns an  $n$ -by- $n$  involutory ( $A^*A = \text{eye}(n)$ ) and ill-conditioned matrix. It is a diagonally scaled version of `hilb(n)`.

$B = (\text{eye}(n) - A)/2$  and  $B = (\text{eye}(n) + A)/2$  are idempotent ( $B^*B = B$ ).

## **ipjfact – Hankel matrix with factorial elements**

`[A,d] = gallery('ipjfact',n,k)` returns  $A$ , an  $n$ -by- $n$  Hankel matrix, and  $d$ , the determinant of  $A$ , which is known explicitly. If  $k = 0$  (the default), then the elements of  $A$  are  $A(i,j) = (i+j)!$ . If  $k = 1$ , then the elements of  $A$  are  $A(i,j) = 1/(i+j)$ .

Note that the inverse of  $A$  is also known explicitly.

## **jordbloc – Jordan block**

`A = gallery('jordbloc',n,lambda)` returns the  $n$ -by- $n$  Jordan block with eigenvalue  $\lambda$ . The default value for  $\lambda$  is 1.

## **kahan – Upper trapezoidal matrix**

`A = gallery('kahan',n,theta,pert)` returns an upper trapezoidal matrix that has interesting properties regarding estimation of condition and rank.

If  $n$  is a two-element vector, then  $A$  is  $n(1)$ -by- $n(2)$ ; otherwise,  $A$  is  $n$ -by- $n$ . The useful range of  $\theta$  is  $0 < \theta < \pi$ , with a default value of 1.2.

To ensure that the QR factorization with column pivoting does not interchange columns in the presence of rounding errors, the diagonal is perturbed by `pert*eps*diag([n:-1:1])`. The default `pert` is 25, which ensures no interchanges for `gallery('kahan',n)` up to at least  $n = 90$  in IEEE arithmetic.



**kms – Kac-Murdock-Szego Toeplitz matrix**

`A = gallery('kms',n,rho)` returns the  $n$ -by- $n$  Kac-Murdock-Szego Toeplitz matrix such that  $A(i,j) = \rho^{(|i-j|)}$ , for real  $\rho$ .

For complex  $\rho$ , the same formula holds except that elements below the diagonal are conjugated.  $\rho$  defaults to 0.5.

The KMS matrix  $A$  has these properties:

- An LDL' factorization with  $L = \text{inv}(\text{gallery('triw',n,-rho,1)})'$ , and  $D(i,i) = (1 - \text{abs}(\rho)^2) * \text{eye}(n)$ , except  $D(1,1) = 1$ .
- Positive definite if and only if  $0 < \text{abs}(\rho) < 1$ .
- The inverse  $\text{inv}(A)$  is tridiagonal.

**krylov – Krylov matrix**

`B = gallery('krylov',A,x,j)` returns the Krylov matrix

`[x, Ax, A^2x, ..., A^(j-1)x]`

where  $A$  is an  $n$ -by- $n$  matrix and  $x$  is a length  $n$  vector. The defaults are  $x = \text{ones}(n,1)$ , and  $j = n$ .

`B = gallery('krylov',n)` is the same as `gallery('krylov',(randn(n)))`.

**lauchli – Rectangular matrix**

`A = gallery('lauchli',n,mu)` returns the  $(n+1)$ -by- $n$  matrix

`[ones(1,n); mu*eye(n)]`

The Lauchli matrix is a well-known example in least squares and other problems that indicates the dangers of forming  $A' * A$ . Argument  $\mu$  defaults to `sqrt(eps)`.

**lehmer – Symmetric positive definite matrix**

`A = gallery('lehmer',n)` returns the symmetric positive definite  $n$ -by- $n$  matrix such that  $A(i,j) = i/j$  for  $j \geq i$ .

The Lehmer matrix  $A$  has these properties:

- A is totally nonnegative.
- The inverse  $\text{inv}(A)$  is tridiagonal and explicitly known.
- The order  $n \leq \text{cond}(A) \leq 4*n*n$ .

## **leslie – Matrix of birth numbers and survival rates**

$L = \text{gallery}('leslie', a, b)$  is the  $n$ -by- $n$  matrix from the Leslie population model with average birth numbers  $a(1:n)$  and survival rates  $b(1:n-1)$ . It is zero, apart from the first row (which contains the  $a(i)$ ) and the first subdiagonal (which contains the  $b(i)$ ). For a valid model, the  $a(i)$  are nonnegative and the  $b(i)$  are positive and bounded by 1, i.e.,  $0 < b(i) \leq 1$ .

$L = \text{gallery}('leslie', n)$  generates the Leslie matrix with  $a = \text{ones}(n, 1)$ ,  $b = \text{ones}(n-1, 1)$ .

## **lesp – Tridiagonal matrix with real, sensitive eigenvalues**

$A = \text{gallery}('lesp', n)$  returns an  $n$ -by- $n$  matrix whose eigenvalues are real and smoothly distributed in the interval approximately  $[-2*N-3.5, -4.5]$ .

The sensitivities of the eigenvalues increase exponentially as the eigenvalues grow more negative. The matrix is similar to the symmetric tridiagonal matrix with the same diagonal entries and with off-diagonal entries 1, via a similarity transformation with  $D = \text{diag}(1!, 2!, \dots, n!)$ .

## **lotkin – Lotkin matrix**

$A = \text{gallery}('lotkin', n)$  returns the Hilbert matrix with its first row altered to all ones. The Lotkin matrix  $A$  is nonsymmetric, ill-conditioned, and has many negative eigenvalues of small magnitude. Its inverse has integer entries and is known explicitly.

## **minij – Symmetric positive definite matrix**

$A = \text{gallery}('minij', n)$  returns the  $n$ -by- $n$  symmetric positive definite matrix with  $A(i, j) = \min(i, j)$ .

The `minij` matrix has these properties:

- The inverse `inv(A)` is tridiagonal and equal to -1 times the second difference matrix, except its  $(n,n)$  element is 1.
- Givens' matrix, `2*A-ones(size(A))`, has tridiagonal inverse and eigenvalues  $0.5*\sec((2*r-1)*\pi/(4*n))^2$ , where  $r=1:n$ .
- $(n+1)*\text{ones}(\text{size}(A)) - A$  has elements that are  $\max(i,j)$  and a tridiagonal inverse.

### **moler – Symmetric positive definite matrix**

`A = gallery('moler',n,alpha)` returns the symmetric positive definite  $n$ -by- $n$  matrix  $U' * U$ , where  $U = \text{gallery}('triu',n,alpha)$ .

For the default  $\alpha = -1$ ,  $A(i,j) = \min(i,j) - 2$ , and  $A(i,i) = i$ . One of the eigenvalues of  $A$  is small.

### **neumann – Singular matrix from the discrete Neumann problem (sparse)**

`C = gallery('neumann',n)` returns the sparse  $n$ -by- $n$  singular, row diagonally dominant matrix resulting from discretizing the Neumann problem with the usual five-point operator on a regular mesh. Argument  $n$  is a perfect square integer  $n = m^2$  or a two-element vector.  $C$  is sparse and has a one-dimensional null space with null vector `ones(n,1)`.

### **normaldata – Array of arbitrary data from standard normal distribution**

`A = gallery('normaldata',[m,n,...],j)` returns an  $m$ -by- $n$ -by-... array  $A$ . The values of  $A$  are a random sample from the standard normal distribution.  $j$  must be an integer value in the interval  $[0, 2^{32}-1]$ . Calling `gallery('normaldata',...)` with different values of  $j$  will return different arrays. Repeated calls to `gallery('normaldata',...)` with the same size vector and  $j$  inputs will always return the same array.

In any call to `gallery('normaldata',...)` you can substitute individual inputs  $m,n,...$  for the size vector input  $[m,n,...]$ . For example, `gallery('normaldata',[1,2,3,4],5)` is equivalent to `gallery('normaldata',1,2,3,4,5)`.

`[A,B,...] = gallery('normaldata',[m,n,...],j)` returns multiple m-by-n-by-... arrays A, B, ..., containing different values.

`A = gallery('normaldata',[m,n,...],j, classname)` produces a matrix of class `classname`. `classname` must be either `'single'` or `'double'`.

Generate the arbitrary 6-by-4 matrix of data from the standard normal distribution  $N(0, 1)$  corresponding to `j = 2`:

```
x = gallery('normaldata', [6, 4], 2);
```

Generate the arbitrary 1-by-2-by-3 single array of data from the standard normal distribution  $N(0, 1)$  corresponding to `j = 17`:

```
y = gallery('normaldata', 1, 2, 3, 17, 'single');
```

## **orthog – Orthogonal and nearly orthogonal matrices**

`Q = gallery('orthog',n,k)` returns the `k`th type of matrix of order `n`, where `k > 0` selects exactly orthogonal matrices, and `k < 0` selects diagonal scalings of orthogonal matrices. Available types are:

`k = 1`       $Q(i,j) = \sqrt{2/(n+1)} * \sin(i*j*\pi/(n+1))$

Symmetric eigenvector matrix for second difference matrix. This is the default.

`k = 2`       $Q(i,j) = 2/(\sqrt{2*n+1}) * \sin(2*i*j*\pi/(2*n+1))$

Symmetric.

`k = 3`       $Q(r,s) = \exp(2*\pi*i*(r-1)*(s-1)/n) / \sqrt{n}$

Unitary, the Fourier matrix.  $Q^4$  is the identity. This is essentially the same matrix as `fft(eye(n))/sqrt(n)!`

`k = 4`      Helmert matrix: a permutation of a lower Hessenberg matrix, whose first row is `ones(1:n)/sqrt(n)`.

$k = 5$       $Q(i, j) = \sin(2\pi(i-1)(j-1)/n) + \cos(2\pi(i-1)(j-1)/n)$

Symmetric matrix arising in the Hartley transform.

$k = 6$       $Q(i, j) = \sqrt{2/n} \cos((i-1/2)(j-1/2)\pi/n)$

Symmetric matrix arising as a discrete cosine transform.

$k = -1$       $Q(i, j) = \cos((i-1)(j-1)\pi/(n-1))$

Chebyshev Vandermonde-like matrix, based on extrema of  $T(n-1)$ .

$k = -2$       $Q(i, j) = \cos((i-1)(j-1/2)\pi/n)$

Chebyshev Vandermonde-like matrix, based on zeros of  $T(n)$ .

### **parter — Toeplitz matrix with singular values near $\pi$**

$C = \text{gallery}('parter', n)$  returns the matrix  $C$  such that  $C(i, j) = 1/(i-j+0.5)$ .

$C$  is a Cauchy matrix and a Toeplitz matrix. Most of the singular values of  $C$  are very close to  $\pi$ .

### **pei — Pei matrix**

$A = \text{gallery}('pei', n, \alpha)$ , where  $\alpha$  is a scalar, returns the symmetric matrix  $\alpha \cdot \text{eye}(n) + \text{ones}(n)$ . The default for  $\alpha$  is 1. The matrix is singular for  $\alpha$  equal to either 0 or  $-n$ .

### **poisson — Block tridiagonal matrix from Poisson's equation (sparse)**

$A = \text{gallery}('poisson', n)$  returns the block tridiagonal (sparse) matrix of order  $n^2$  resulting from discretizing Poisson's equation with the 5-point operator on an  $n$ -by- $n$  mesh.

### **prolate — Symmetric, ill-conditioned Toeplitz matrix**

$A = \text{gallery}('prolate', n, w)$  returns the  $n$ -by- $n$  prolate matrix with parameter  $w$ . It is a symmetric Toeplitz matrix.

If  $0 < w < 0.5$  then  $A$  is positive definite

- The eigenvalues of  $A$  are distinct, lie in  $(0, 1)$ , and tend to cluster around 0 and 1.
- The default value of  $w$  is 0.25.

## **randcolu – Random matrix with normalized cols and specified singular values**

`A = gallery('randcolu', n)` is a random  $n$ -by- $n$  matrix with columns of unit 2-norm, with random singular values whose squares are from a uniform distribution.

$A^*A$  is a correlation matrix of the form produced by `gallery('randcorr', n)`.

`gallery('randcolu', x)` where  $x$  is an  $n$ -vector ( $n > 1$ ), produces a random  $n$ -by- $n$  matrix having singular values given by the vector  $x$ . The vector  $x$  must have nonnegative elements whose sum of squares is  $n$ .

`gallery('randcolu', x, m)` where  $m \geq n$ , produces an  $m$ -by- $n$  matrix.

`gallery('randcolu', x, m, k)` provides a further option:

- |         |                                                                                                                                                            |
|---------|------------------------------------------------------------------------------------------------------------------------------------------------------------|
| $k = 0$ | <code>diag(x)</code> is initially subjected to a random two-sided orthogonal transformation, and then a sequence of Givens rotations is applied (default). |
| $k = 1$ | The initial transformation is omitted. This is much faster, but the resulting matrix may have zero entries.                                                |

For more information, see:

## References

[1] Davies, P. I. and N. J. Higham, “Numerically Stable Generation of Correlation Matrices and Their Factors,” *BIT*, Vol. 40, 2000, pp. 640-651.

### **randcorr – Random correlation matrix with specified eigenvalues**

`gallery('randcorr',n)` is a random  $n$ -by- $n$  correlation matrix with random eigenvalues from a uniform distribution. A correlation matrix is a symmetric positive semidefinite matrix with 1s on the diagonal (see `corrcoef`).

`gallery('randcorr',x)` produces a random correlation matrix having eigenvalues given by the vector  $x$ , where  $\text{length}(x) > 1$ . The vector  $x$  must have nonnegative elements summing to  $\text{length}(x)$ .

`gallery('randcorr',x,k)` provides a further option:

- |         |                                                                                                                                                                           |
|---------|---------------------------------------------------------------------------------------------------------------------------------------------------------------------------|
| $k = 0$ | The diagonal matrix of eigenvalues is initially subjected to a random orthogonal similarity transformation, and then a sequence of Givens rotations is applied (default). |
| $k = 1$ | The initial transformation is omitted. This is much faster, but the resulting matrix may have some zero entries.                                                          |

For more information, see:

## References

[1] Bendel, R. B. and M. R. Mickey, “Population Correlation Matrices for Sampling Experiments,” *Commun. Statist. Simulation Comput.*, B7, 1978, pp. 163-182.

[2] Davies, P. I. and N. J. Higham, “Numerically Stable Generation of Correlation Matrices and Their Factors,” *BIT*, Vol. 40, 2000, pp. 640-651.

## **randhess — Random, orthogonal upper Hessenberg matrix**

`H = gallery('randhess', n)` returns an  $n$ -by- $n$  real, random, orthogonal upper Hessenberg matrix.

`H = gallery('randhess', x)` if  $x$  is an arbitrary, real, length  $n$  vector with  $n > 1$ , constructs  $H$  nonrandomly using the elements of  $x$  as parameters.

Matrix  $H$  is constructed via a product of  $n-1$  Givens rotations.

## **randjorth — Random J-orthogonal matrix**

`A = gallery('randjorth', n)`, for a positive integer  $n$ , produces a random  $n$ -by- $n$  J-orthogonal matrix  $A$ , where

- `J = blkdiag(eye(ceil(n/2)), -eye(floor(n/2)))`
- `cond(A) = sqrt(1/eps)`

J-orthogonality means that  $A^*JA = J$ . Such matrices are sometimes called *hyperbolic*.

`A = gallery('randjorth', n, m)`, for positive integers  $n$  and  $m$ , produces a random  $(n+m)$ -by- $(n+m)$  J-orthogonal matrix  $A$ , where

- `J = blkdiag(eye(n), -eye(m))`
- `cond(A) = sqrt(1/eps)`

`A = gallery('randjorth', n, m, c, symm, method)`

uses the following optional input arguments:

- `c` — Specifies `cond(A)` to be the scalar  $c$ .
- `symm` — Enforces symmetry if the scalar `symm` is nonzero.
- `method` — calls `qr` to perform the underlying orthogonal transformations if the scalar `method` is nonzero. A call to `qr` is much faster than the default method for large dimensions



**rando – Random matrix composed of elements -1, 0 or 1**

`A = gallery('rando', n, k)` returns a random  $n$ -by- $n$  matrix with elements from one of the following discrete distributions:

- |                    |                                                                 |
|--------------------|-----------------------------------------------------------------|
| <code>k = 1</code> | <code>A(i, j) = 0 or 1</code> with equal probability (default). |
| <code>k = 2</code> | <code>A(i, j) = -1 or 1</code> with equal probability.          |
| <code>k = 3</code> | <code>A(i, j) = -1, 0 or 1</code> with equal probability.       |

Argument  $n$  may be a two-element vector, in which case the matrix is  $n(1)$ -by- $n(2)$ .

**randsvd – Random matrix with preassigned singular values**

`A = gallery('randsvd', n, kappa, mode, k1, ku)` returns a banded (multidiagonal) random matrix of order  $n$  with  $\text{cond}(A) = \text{kappa}$  and singular values from the distribution `mode`. If  $n$  is a two-element vector,  $A$  is  $n(1)$ -by- $n(2)$ .

Arguments `k1` and `ku` specify the number of lower and upper off-diagonals, respectively, in  $A$ . If they are omitted, a full matrix is produced. If only `k1` is present, `ku` defaults to `k1`.

Distribution `mode` can be:

- 1 One large singular value.
  - 2 One small singular value.
  - 3 Geometrically distributed singular values (default).
  - 4 Arithmetically distributed singular values.
  - 5 Random singular values with uniformly distributed logarithm.
- < 0 If `mode` is -1, -2, -3, -4, or -5, then `randsvd` treats `mode` as `abs(mode)`, except that in the original matrix of singular values the order of the diagonal entries is reversed: small to large instead of large to small.

Condition number kappa defaults to  $\sqrt{1/\text{eps}}$ . In the special case where  $\text{kappa} < 0$ , A is a random, full, symmetric, positive definite matrix with  $\text{cond}(A) = -\text{kappa}$  and eigenvalues distributed according to mode. Arguments k1 and ku, if present, are ignored.

`A = gallery('randsvd', n, kappa, mode, k1, ku, method)` specifies how the computations are carried out. `method = 0` is the default, while `method = 1` uses an alternative method that is much faster for large dimensions, even though it uses more flops.

## **redheff – Redheffer’s matrix of 1s and 0s**

`A = gallery('redheff', n)` returns an n-by-n matrix of 0’s and 1’s defined by  $A(i, j) = 1$ , if  $j = 1$  or if  $i$  divides  $j$ , and  $A(i, j) = 0$  otherwise.

The Redheffer matrix has these properties:

- $(n - \text{floor}(\log_2(n))) - 1$  eigenvalues equal to 1
- A real eigenvalue (the spectral radius) approximately  $\sqrt{n}$
- A negative eigenvalue approximately  $-\sqrt{n}$
- The remaining eigenvalues are provably “small.”
- The Riemann hypothesis is true if and only if  $\det(A) = O(n^{1/2+\varepsilon})$  for every  $\varepsilon > 0$ .

Barrett and Jarvis conjecture that “the small eigenvalues all lie inside the unit circle  $\text{abs}(Z) = 1$ ,” and a proof of this conjecture, together with a proof that some eigenvalue tends to zero as  $n$  tends to infinity, would yield a new proof of the prime number theorem.

## **riemann – Matrix associated with the Riemann hypothesis**

`A = gallery('riemann', n)` returns an n-by-n matrix for which the Riemann hypothesis is true if and only if

$$\det(A) = O(n!n^{-1/2+\varepsilon})$$

for every  $\varepsilon > 0$ .

The Riemann matrix is defined by:

$$A = B(2:n+1, 2:n+1)$$

where  $B(i, j) = i^{-1}$  if  $i$  divides  $j$ , and  $B(i, j) = -1$  otherwise.

The Riemann matrix has these properties:

- Each eigenvalue  $e(i)$  satisfies  $\text{abs}(e(i)) \leq m^{-1}/m$ , where  $m = n+1$ .
- $i \leq e(i) \leq i+1$  with at most  $m - \text{sqrt}(m)$  exceptions.
- All integers in the interval  $(m/3, m/2]$  are eigenvalues.

### **ris — Symmetric Hankel matrix**

`A = gallery('ris', n)` returns a symmetric  $n$ -by- $n$  Hankel matrix with elements

$$A(i, j) = 0.5 / (n - i - j + 1.5)$$

The eigenvalues of  $A$  cluster around  $\pi/2$  and  $-\pi/2$ . This matrix was invented by F.N. Ris.

### **sampling — Nonsymmetric matrix with ill-conditioned integer eigenvalues.**

`A = gallery('sampling', x)`, where  $x$  is an  $n$ -vector, is the  $n$ -by- $n$  matrix with  $A(i, j) = X(i) / (X(i) - X(j))$  for  $i \neq j$  and  $A(j, j)$  the sum of the off-diagonal elements in column  $j$ .  $A$  has eigenvalues  $0:n-1$ . For the eigenvalues  $0$  and  $n-1$ , corresponding eigenvectors are `X` and `ones(n, 1)`, respectively.

The eigenvalues are ill-conditioned.  $A$  has the property that  $A(i, j) + A(j, i) = 1$  for  $i \neq j$ .

Explicit formulas are available for the left eigenvectors of  $A$ . For scalar  $n$ , `sampling(n)` is the same as `sampling(1:n)`. A special case of this matrix arises in sampling theory.

## **smoke – Complex matrix with a ‘smoke ring’ pseudospectrum**

`A = gallery('smoke', n)` returns an  $n$ -by- $n$  matrix with 1's on the superdiagonal, 1 in the  $(n, 1)$  position, and powers of roots of unity along the diagonal.

`A = gallery('smoke', n, 1)` returns the same except that element  $A(n, 1)$  is zero.

The eigenvalues of `gallery('smoke', n, 1)` are the  $n$ th roots of unity; those of `gallery('smoke', n)` are the  $n$ th roots of unity times  $2^{(1/n)}$ .

## **toeppd – Symmetric positive definite Toeplitz matrix**

`A = gallery('toeppd', n, m, w, theta)` returns an  $n$ -by- $n$  symmetric, positive semi-definite (SPD) Toeplitz matrix composed of the sum of  $m$  rank 2 (or, for certain  $\theta$ , rank 1) SPD Toeplitz matrices. Specifically,

$$T = w(1)*T(\theta(1)) + \dots + w(m)*T(\theta(m))$$

where  $T(\theta(k))$  has  $(i, j)$  element  $\cos(2*\pi*\theta(k)*(i-j))$ .

By default:  $m = n$ ,  $w = \text{rand}(m, 1)$ , and  $\theta = \text{rand}(m, 1)$ .

## **toeppen – Pentadiagonal Toeplitz matrix (sparse)**

`P = gallery('toeppen', n, a, b, c, d, e)` returns the  $n$ -by- $n$  sparse, pentadiagonal Toeplitz matrix with the diagonals:  $P(3, 1) = a$ ,  $P(2, 1) = b$ ,  $P(1, 1) = c$ ,  $P(1, 2) = d$ , and  $P(1, 3) = e$ , where  $a$ ,  $b$ ,  $c$ ,  $d$ , and  $e$  are scalars.

By default,  $(a, b, c, d, e) = (1, -10, 0, 10, 1)$ , yielding a matrix of Rutishauser. This matrix has eigenvalues lying approximately on the line segment  $2*\cos(2*t) + 20*i*\sin(t)$ .

## **tridiag – Tridiagonal matrix (sparse)**

`A = gallery('tridiag', c, d, e)` returns the tridiagonal matrix with subdiagonal  $c$ , diagonal  $d$ , and superdiagonal  $e$ . Vectors  $c$  and  $e$  must have  $\text{length}(d) - 1$ .

`A = gallery('tridiag',n,c,d,e)`, where `c`, `d`, and `e` are all scalars, yields the Toeplitz tridiagonal matrix of order `n` with subdiagonal elements `c`, diagonal elements `d`, and superdiagonal elements `e`. This matrix has eigenvalues

$$d + 2*\sqrt{c*e}*\cos(k*pi/(n+1))$$

where `k = 1:n`. (see [1].)

`A = gallery('tridiag',n)` is the same as `A = gallery('tridiag',n,-1,2,-1)`, which is a symmetric positive definite M-matrix (the negative of the second difference matrix).

### **triw – Upper triangular matrix discussed by Wilkinson and others**

`A = gallery('triw',n,alpha,k)` returns the upper triangular matrix with ones on the diagonal and alphas on the first `k >= 0` superdiagonals.

Order `n` may be a 2-element vector, in which case the matrix is `n(1)`-by-`n(2)` and upper trapezoidal.

Ostrowski [“On the Spectrum of a One-parametric Family of Matrices,” *J. Reine Angew. Math.*, 1954] shows that

$$\text{cond}(\text{gallery}('triw',n,2)) = \cot(\pi/(4*n))^2,$$

and, for large `abs(alpha)`, `cond(gallery('triw',n,alpha))` is approximately `abs(alpha)^n*sin(pi/(4*n-2))`.

Adding `-2^(2-n)` to the `(n,1)` element makes `triw(n)` singular, as does adding `-2^(1-n)` to all the elements in the first column.

### **uniformdata – Array of arbitrary data from standard uniform distribution**

`A = gallery('uniformdata',[m,n,...],j)` returns an `m`-by-`n`-by-... array `A`. The values of `A` are a random sample from the standard uniform distribution. `j` must be an integer value in the interval `[0, 2^32-1]`. Calling `gallery('uniformdata',...)` with different values of `j` will return different arrays. Repeated calls to

`gallery('uniformdata',...)` with the same size vector and `j` inputs will always return the same array.

In any call to `gallery('uniformdata', ...)` you can substitute individual inputs `m,n,...` for the size vector input `[m,n,...]`. For example, `gallery('uniformdata',[1,2,3,4],5)` is equivalent to `gallery('uniformdata',1,2,3,4,5)`.

`[A,B,...] = gallery('uniformdata',[m,n,...],j)` returns multiple `m`-by-`n`-by-... arrays `A, B, ...`, containing different values.

`A = gallery('uniformdata',[m,n,...],j, classname)` produces a matrix of class `classname`. `classname` must be either `'single'` or `'double'`.

Generate the arbitrary 6-by-4 matrix of data from the uniform distribution on `[0, 1]` corresponding to `j = 2`.

```
x = gallery('uniformdata', [6, 4], 2);
```

Generate the arbitrary 1-by-2-by-3 single array of data from the uniform distribution on `[0, 1]` corresponding to `j = 17`.

```
y = gallery('uniformdata', 1, 2, 3, 17, 'single');
```

## **wathen – Finite element matrix (sparse, random entries)**

`A = gallery('wathen',nx,ny)` returns a sparse, random, `n`-by-`n` finite element matrix where  $n = 3 \cdot nx \cdot ny + 2 \cdot nx + 2 \cdot ny + 1$ .

Matrix `A` is precisely the “consistent mass matrix” for a regular `nx`-by-`ny` grid of 8-node (serendipity) elements in two dimensions. `A` is symmetric, positive definite for any (positive) values of the “density,” `rho(nx,ny)`, which is chosen randomly in this routine.

`A = gallery('wathen',nx,ny,1)` returns a diagonally scaled matrix such that

```
0.25 <= eig(inv(D)*A) <= 4.5
```

where `D = diag(diag(A))` for any positive integers `nx` and `ny` and any densities `rho(nx,ny)`.

**wilk – Various matrices devised or discussed by Wilkinson**

`gallery('wilk',n)` returns a different matrix or linear system depending on the value of `n`.

|                     |                                                                                         |
|---------------------|-----------------------------------------------------------------------------------------|
| <code>n = 3</code>  | Upper triangular system $Ux=b$ illustrating inaccurate solution.                        |
| <code>n = 4</code>  | Lower triangular system $Lx=b$ , ill-conditioned.                                       |
| <code>n = 5</code>  | <code>hilb(6)(1:5,2:6)*1.8144</code> . A symmetric positive definite matrix.            |
| <code>n = 21</code> | <code>W21+</code> , a tridiagonal matrix. eigenvalue problem. For more detail, see [2]. |

**References**

[1] The MATLAB gallery of test matrices is based upon the work of Nicholas J. Higham at the Department of Mathematics, University of Manchester, Manchester, England. Further background can be found in the books *MATLAB Guide, Second Edition*, Desmond J. Higham and Nicholas J. Higham, SIAM, 2005, and *Accuracy and Stability of Numerical Algorithms*, Nicholas J. Higham, SIAM, 1996.

[2] Wilkinson, J. H., *The Algebraic Eigenvalue Problem*, Oxford University Press, London, 1965, p.308.

**See Also**

`hadamard` | `hilb` | `invhilb` | `magic` | `wilkinson`

# gamma

---

**Purpose** Gamma function

**Syntax** `Y = gamma(X)`

**Definitions** The gamma function is defined by the integral:

$$\Gamma(x) = \int_0^{\infty} e^{-t} t^{x-1} dt$$

The gamma function interpolates the factorial function. For integer  $n$ :

$$\text{gamma}(n+1) = n! = \text{prod}(1:n)$$

**Description** `Y = gamma(X)` returns the gamma function at the elements of  $X$ .  $X$  must be real.

**Algorithms** The computation of `gamma` is based on algorithms outlined in [1]. Several different minimax rational approximations are used depending upon the value of  $A$ .

**References** [1] Cody, J., *An Overview of Software Development for Special Functions*, Lecture Notes in Mathematics, 506, Numerical Analysis Dundee, G. A. Watson (ed.), Springer Verlag, Berlin, 1976.

[2] Abramowitz, M. and I.A. Stegun, *Handbook of Mathematical Functions*, National Bureau of Standards, Applied Math. Series #55, Dover Publications, 1965, sec. 6.5.

**See Also** `gammaln` | `gamma` | `psi`



**Purpose** Incomplete gamma function

**Syntax**  
`Y = gammainc(X,A)`  
`Y = gammainc(X,A,tail)`  
`Y = gammainc(X,A,'scaledlower')`  
`Y = gammainc(X,A,'scaledupper')`

**Definitions** The incomplete gamma function is:

$$P(a,x) = \frac{1}{\Gamma(a)} \int_0^x e^{-t} t^{a-1} dt$$

---

**Note** The syntax `gammainc(X,A)` is equivalent to the function  $P(A,X)$  defined above, where  $X$  is the limit of integration in each case.

---

For any  $A \geq 0$ , `gammainc(X,A)` approaches 1 as  $X$  approaches infinity. For small  $X$  and  $A$ , `gammainc(X,A)` is approximately equal to  $X^A$ , so `gammainc(0,0) = 1`.

**Description** `Y = gammainc(X,A)` returns the incomplete gamma function of corresponding elements of  $X$  and  $A$ . The elements of  $A$  must be nonnegative. Furthermore,  $X$  and  $A$  must be real and the same size (or either can be scalar).

`Y = gammainc(X,A,tail)` specifies the tail of the incomplete gamma function. The choices for `tail` are 'lower' (the default) and 'upper'. The upper incomplete gamma function is defined as:

$$Q(a,x) = \frac{1}{\Gamma(a)} \int_x^\infty e^{-t} t^{a-1} dt = 1 - P(a,x).$$

When the upper tail value is close to 0, the 'upper' option provides a way to compute that value more accurately than by subtracting the lower tail value from 1.

# gammainc

---

$Y = \text{gammainc}(X,A, \text{'scaledlower'})$  and  $Y = \text{gammainc}(X,A, \text{'scaledupper'})$  return the incomplete gamma function, scaled by

$$\Gamma(a+1) \left( \frac{e^x}{x^a} \right).$$

These functions are unbounded above, but are useful for values of  $X$  and  $A$  where  $\text{gammainc}(X,A, \text{'lower'})$  or  $\text{gammainc}(X,A, \text{'upper'})$  underflow to zero.

---

**Note** When  $X$  is negative,  $Y$  can be inaccurate for  $\text{abs}(X) > A+1$ . This applies to all syntaxes.

---

## References

- [1] Cody, J., *An Overview of Software Development for Special Functions*, Lecture Notes in Mathematics, 506, Numerical Analysis Dundee, G. A. Watson (ed.), Springer Verlag, Berlin, 1976.
- [2] Abramowitz, M. and I.A. Stegun, *Handbook of Mathematical Functions*, National Bureau of Standards, Applied Math. Series #55, Dover Publications, 1965, sec. 6.5.

## See Also

[gamma](#) | [gammaincinv](#) | [gamma1n](#) | [psi](#)

**Purpose** Inverse incomplete gamma function

**Syntax**  
`x = gammaincinv(y,a)`  
`y = gammaincinv(x,a,tail)`

**Description** `x = gammaincinv(y,a)` evaluates the inverse incomplete gamma function for corresponding elements of `y` and `a`, such that `y = gammainc(x,a)`. The elements of `y` must be in the closed interval `[0,1]`, and those of `a` must be nonnegative. `y` and `a` must be real and the same size (or either can be a scalar).

`y = gammaincinv(x,a,tail)` specifies the tail of the incomplete gamma function. Choices are `lower` (the default) to use the integral from 0 to `x`, or `upper` to use the integral from `x` to infinity.

These two choices are related as:

`gammaincinv(y,a,'upper') = gammaincinv(1-y,a,'lower')`.

When `y` is close to 0, the `upper` option provides a way to compute `x` more accurately than by subtracting `y` from 1.

**Definitions** The lower incomplete gamma function is defined as:

$$\text{gammainc}(x,a) = \frac{1}{\Gamma(a)} \int_0^x e^{-t} t^{(a-1)} dt$$

The upper incomplete gamma function is defined as:

$$\text{gammainc}(x,a) = \frac{1}{\Gamma(a)} \int_x^\infty e^{-t} t^{(a-1)} dt$$

`gammaincinv` computes the inverse of the incomplete gamma function with respect to the integration limit `x` using Newton's method.

For any `a>0`, as `y` approaches 1, `gammaincinv(y,a)` approaches infinity.

For small `x` and `a`, `gammainc(x,a) ≅ xa`, so `gammaincinv(1,0) = 0`.

# gammaincinv

---

## References

[1] Cody, J., *An Overview of Software Development for Special Functions*, Lecture Notes in Mathematics, 506, Numerical Analysis Dundee, G. A. Watson (ed.), Springer Verlag, Berlin, 1976.

[2] Abramowitz, M. and I.A. Stegun, *Handbook of Mathematical Functions*, National Bureau of Standards, Applied Math. Series #55, Dover Publications, 1965, sec. 6.5.

## See Also

gamma | gammainc | gammaIn | psi

**Purpose**            Logarithm of gamma function

**Syntax**             $Y = \text{gammaln}(A)$

**Description**         $Y = \text{gammaln}(A)$  returns the logarithm of the gamma function,  $\text{gammaln}(A) = \log(\text{gamma}(A))$ . Input  $A$  must be nonnegative and real. The `gammaln` command avoids the underflow and overflow that may occur if it is computed directly using  $\log(\text{gamma}(A))$ .

**See Also**            `gammainc` | `gammaincinv` | `gamma` | `psi`

**Purpose** Current axes handle

**Syntax** `h = gca`

**Description** `h = gca` returns the handle to the current axes for the current figure. If an axes does not exist, then `gca` creates an axes and returns its handle. You can use the axes handle to query and modify axes properties. For more information, see [Axes Properties](#).

## **Examples** **Specify Properties for Current Axes**

Plot a sine wave. Use the `gca` command to set the font size, tick direction, tick length, and *y*-axis limits for the current axes.

```
x = linspace(0,10);
y = sin(4*x);
figure;
plot(x,y);
set(gca, 'FontSize', 12, ...
 'TickDir', 'out', ...
 'TickLength', [.02, .02], ...
 'YLim', [-2, 2])
```

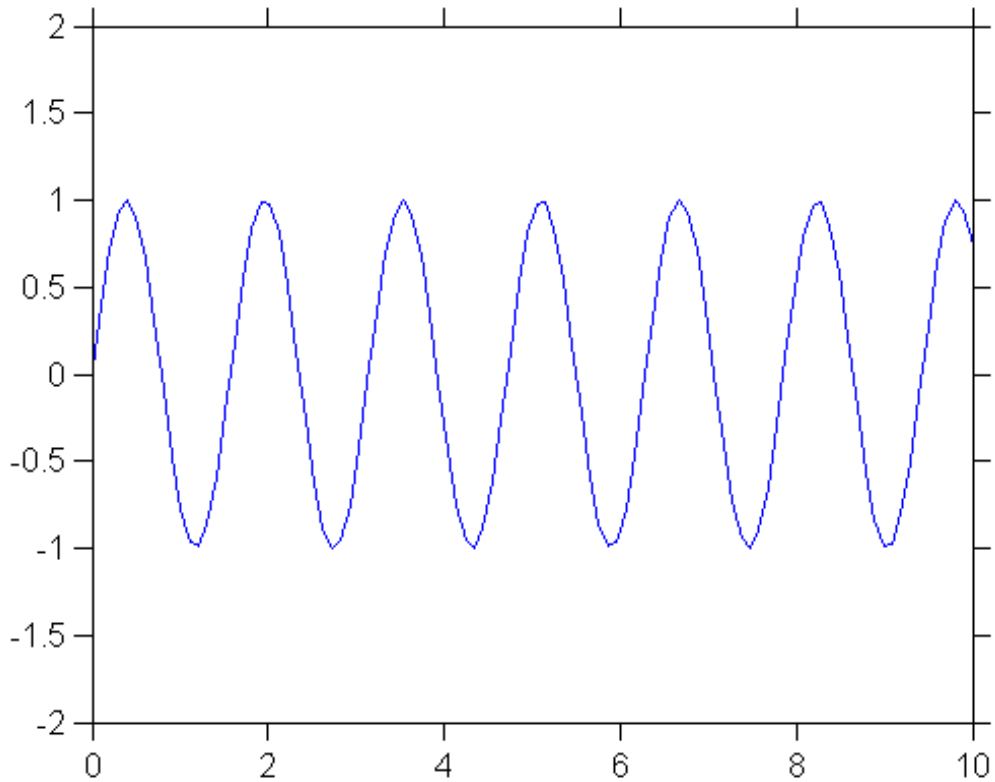
**Tips**

- To view a list of all the axes properties, execute `get(gca)`.
- To get the handle of the current axes without forcing the creation of an axes if one does not exist, query the figure `CurrentAxes` property.

```
h = get(gcf, 'CurrentAxes')
```

MATLAB returns `h` as an empty array if there is no current axes.

- Set axes properties after plotting since some plotting functions reset axes properties.

**Definitions****Current Axes**

The current axes is the target for graphics output. It is the axes in which graphics commands such as `plot`, `text`, and `surf` draw their results. It is typically the last axes created or the last axes clicked with the mouse. Changing the current figure also changes the current axes.

User interaction can change the current axes. If you need to access a specific axes, store the axes handle in your program code when you create the axes and use this handle instead of `gca`.

**See Also**

`axes` | `cla` | `gcf` | `findobj` | `get` | `set` | Axes Properties

**Concepts**

- “The Current Figure, Axes, and Object”
- “Accessing Object Handles”



**Purpose** Handle of figure containing object whose callback is executing

**Syntax** `fig = gcbf`

**Description** `fig = gcbf` returns the handle of the figure that contains the object whose callback is currently executing. This object can be the figure itself, in which case, `gcbf` returns the figure's handle.

When no callback is executing, `gcbf` returns the empty matrix, `[]`.

The value returned by `gcbf` is identical to the figure output argument returned by `gcbo`.

**See Also** `gcbo` | `gco` | `gcf` | `gca`

**Purpose** Handle of object whose callback is executing

**Syntax** `h = gcbo`  
`[h,figure] = gcbo`

**Description** `h = gcbo` returns the handle of the graphics object whose callback is executing.

`[h,figure] = gcbo` returns the handle of the current callback object and the handle of the figure containing this object.

**Tips** The MATLAB software stores the handle of the object whose callback is executing in the root `CallbackObject` property. If a callback interrupts another callback, MATLAB replaces the `CallbackObject` value with the handle of the object whose callback is interrupting. When that callback completes, MATLAB restores the handle of the object whose callback was interrupted.

The root `CallbackObject` property is read only, so its value is always valid at any time during callback execution. The root `CurrentFigure` property, and the figure `CurrentAxes` and `CurrentObject` properties (returned by `gcf`, `gca`, and `gco`, respectively) are user settable, so they can change during the execution of a callback, especially if that callback is interrupted by another callback. Therefore, those functions are not reliable indicators of which object's callback is executing.

When you write callback routines for the `CreateFcn` and `DeleteFcn` of any object and the figure `ResizeFcn`, you must use `gcbo` since those callbacks do not update the root's `CurrentFigure` property, or the figure's `CurrentObject` or `CurrentAxes` properties; they only update the root's `CurrentFigure` property.

When no callbacks are executing, `gcbo` returns `[]` (an empty matrix).

**See Also** `gca` | `gcf` | `gco` | `rootobject`

**Purpose**

Greatest common divisor

**Syntax**

```
G = gcd(A,B)
[G,U,V] = gcd(A,B)
```

**Description**

`G = gcd(A,B)` returns the greatest common divisors of the elements of `A` and `B`. The elements in `G` are always nonnegative, and `gcd(0,0)` returns 0. This syntax supports inputs of any numeric type.

`[G,U,V] = gcd(A,B)` also returns the Bézout coefficients, `U` and `V`, which satisfy:  $A.*U + B.*V = G$ . The Bézout coefficients are useful for solving Diophantine equations. This syntax supports double, single, and signed integer inputs.

**Input Arguments****A,B - Input values**

scalars, vectors, or arrays of real integer values

Input values, specified as scalars, vectors, or arrays of real integer values. `A` and `B` can be any numeric type, and they can be of different types within certain limitations:

- If `A` or `B` is of type `single`, then the other can be of type `single` or `double`.
- If `A` or `B` belongs to an integer class, then the other must belong to the same class or it must be a `double` scalar value.

`A` and `B` must be the same size or one must be a scalar.

**Example:** `[20 -3 13],[10 6 7]`

**Example:** `int16([100 -30 200]),int16([20 15 9])`

**Example:** `int16([100 -30 200]),20`

**Data Types**

```
single | double | int8 | int16 | int32 | int64 | uint8 |
uint16 | uint32 | uint64
```

## Output Arguments

### **G - Greatest common divisor**

real, nonnegative integer values

Greatest common divisor, returned as an array of real nonnegative integer values. **G** is the same size as **A** and **B**, and the values in **G** are always real and nonnegative. **G** is returned as the same type as **A** and **B**. If **A** and **B** are of different types, then **G** is returned as the nondouble type.

### **U,V - Bézout coefficients**

real integer values

Bézout coefficients, returned as arrays of real integer values that satisfy the equation,  $A \cdot U + B \cdot V = G$ . The data type of **U** and **V** is the same type as that of **A** and **B**. If **A** and **B** are of different types, then **U** and **V** are returned as the nondouble type.

## Algorithms

$g = \text{gcd}(A,B)$  is calculated using the Euclidian algorithm.[1]

$[g,u,v] = \text{gcd}(A,B)$  is calculated using the extended Euclidian algorithm.[1]

## Examples

### **Greatest Common Divisors of Double Values**

```
A = [-5 17; 10 0];
B = [-15 3; 100 0];
G = gcd(A,B)
```

```
G =
```

```
 5 1
 10 0
```

gcd returns positive values, even when the inputs are negative.

### **Greatest Common Divisors of Unsigned Integers**

```
A = uint16([255 511 15]);
B = uint16([15 127 1023]);
```

$$G = \gcd(A, B)$$

$$G =$$

$$15 \quad 1 \quad 3$$

### Solution to Diophantine Equation

Solve the Diophantine equation,  $30x + 56y = 8$  for  $x$  and  $y$ .

Find the greatest common divisor and a pair of Bézout coefficients for 30 and 56.

$$[g, u, v] = \gcd(30, 56)$$

$$g =$$

$$2$$

$$u =$$

$$-13$$

$$v =$$

$$7$$

$u$  and  $v$  satisfy the Bézout's identity,  $(30*u) + (56*v) = g$ .

Rewrite Bézout's identity so that it looks more like the original equation. Do this by multiplying by 4. Use `==` to verify that both sides of the equation are equal.

$$(30*u*4) + (56*v*4) == g*4$$

$$\text{ans} =$$

$$1$$

Calculate the values of  $x$  and  $y$  that solve the problem.

$$x = u*4$$

$$y = v*4$$

$$x =$$

$$-52$$

$$y =$$

$$28$$

## References

[1] Knuth, D. "Algorithms A and X." *The Art of Computer Programming*, Vol. 2, Section 4.5.2. Reading, MA: Addison-Wesley, 1973.

## See Also

1cm

---

|                    |                                                                                                                                                                                                                                                                                       |
|--------------------|---------------------------------------------------------------------------------------------------------------------------------------------------------------------------------------------------------------------------------------------------------------------------------------|
| <b>Purpose</b>     | Current figure handle                                                                                                                                                                                                                                                                 |
| <b>Syntax</b>      | <code>h = gcf</code>                                                                                                                                                                                                                                                                  |
| <b>Description</b> | <code>h = gcf</code> returns the current figure handle. If a figure does not exist, then <code>gcf</code> creates a figure and returns its handle. You can use the figure handle to query and modify figure properties. For more information, see <a href="#">Figure Properties</a> . |
| <b>Examples</b>    | <b>Specify Properties for Current Figure</b><br>Set the background color and remove the toolbar for the current figure using the <code>gcf</code> command.<br><pre>figure surf(peaks); set(gcf, 'Color', [0,0.5,0.5], ...         'Toolbar', 'none')</pre>                            |

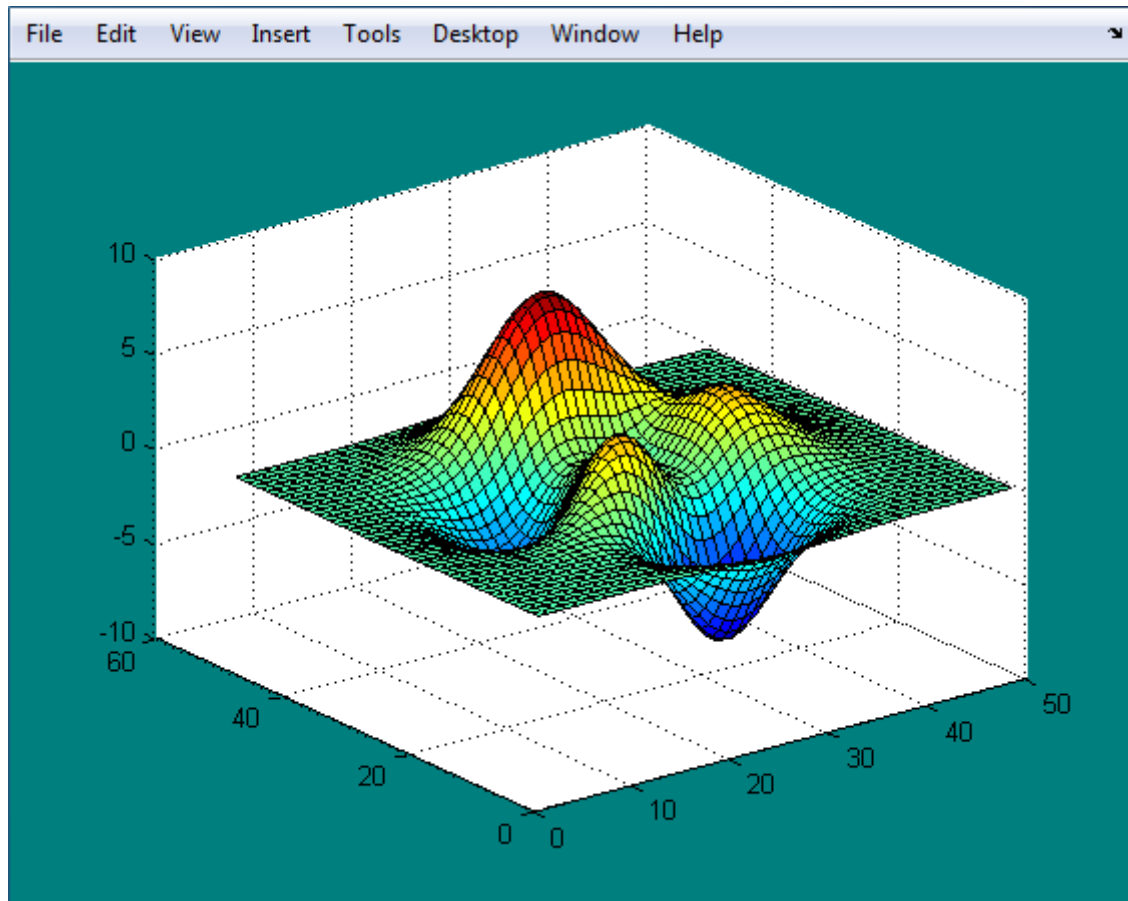
**Definitions****Current Figure**

The current figure is the target for graphics output. It is the figure window in which graphics commands such as `plot`, `title`, and `surf` draw their results. It is typically the last figure created or the last figure clicked with the mouse.



---

User interaction can change the current figure. If you need to access a specific figure, store the figure handle in your program code when you create the figure and use this handle instead of `gcf`.

**Tips**

- To view a list of all figure properties, execute `get(gcf)`.
- To get the handle of the current figure without forcing the creation of a figure if one does not exist, query the `CurrentFigure` property on the root object.

```
h = get(0, 'CurrentFigure')
```

MATLAB returns `h` as an empty array if there is no current figure.

**See Also**

[figure](#) | [clf](#) | [gca](#) | [get](#) | [set](#) | [Figure Properties](#)

**Concepts**

- “The Current Figure, Axes, and Object”
- “Accessing Object Handles”

**Purpose**

Handle of current object

**Syntax**

```
h = gco
h = gco(figure_handle)
```

**Description**

`h = gco` returns the handle of the current object.

`h = gco(figure_handle)` returns the handle of the current object in the figure specified by *figure\_handle*.

**Tips**

The current object is the last object clicked on, excluding `uimenu`s. If the mouse click did not occur over a figure child object, the figure becomes the current object. The MATLAB software stores the handle of the current object in the figure's `CurrentObject` property.

The `CurrentObject` of the `CurrentFigure` does not always indicate the object whose callback is being executed. Interruptions of callbacks by other callbacks can change the `CurrentObject` or even the `CurrentFigure`. Some callbacks, such as `CreateFcn` and `DeleteFcn`, and `uimenu Callback`, intentionally do not update `CurrentFigure` or `CurrentObject`.

`gco` provides the only completely reliable way to retrieve the handle to the object whose callback is executing, at any point in the callback function, regardless of the type of callback or of any previous interruptions.

**See Also**

`gca` | `gcbo` | `gcf`

|                        |                                                                                                                                                                                                                                                                                                                                                                                                                                                                                                                                                                                                                                                                                                                                                                                                                                                                                                                                                                                                                                                                |
|------------------------|----------------------------------------------------------------------------------------------------------------------------------------------------------------------------------------------------------------------------------------------------------------------------------------------------------------------------------------------------------------------------------------------------------------------------------------------------------------------------------------------------------------------------------------------------------------------------------------------------------------------------------------------------------------------------------------------------------------------------------------------------------------------------------------------------------------------------------------------------------------------------------------------------------------------------------------------------------------------------------------------------------------------------------------------------------------|
| <b>Purpose</b>         | Determine greater than or equal to                                                                                                                                                                                                                                                                                                                                                                                                                                                                                                                                                                                                                                                                                                                                                                                                                                                                                                                                                                                                                             |
| <b>Syntax</b>          | A >= B<br>ge(A,B)                                                                                                                                                                                                                                                                                                                                                                                                                                                                                                                                                                                                                                                                                                                                                                                                                                                                                                                                                                                                                                              |
| <b>Description</b>     | <p>A &gt;= B returns a logical array with elements set to logical 1 (true) where A is greater than or equal to B; otherwise, it returns logical 0 (false). The test compares only the real part of numeric arrays. ge returns logical 0 (false) where A or B have NaN or undefined categorical elements.</p> <p>ge(A,B) is an alternate way to execute A &gt;= B, but is rarely used. It enables operator overloading for classes.</p>                                                                                                                                                                                                                                                                                                                                                                                                                                                                                                                                                                                                                         |
| <b>Input Arguments</b> | <p><b>A - Left array</b><br/>numeric array   logical array   character array   ordinal categorical array</p> <p>Left array, specified as a numeric array, logical array, character array, or categorical array. Inputs A and B must be the same size unless one is a scalar. A scalar input expands into an array of the same size as the other input.</p> <p>If one input is an ordinal categorical array, the other input can be an ordinal categorical array, a cell array of strings, or a single string. A single string expands into a cell array of strings of the same size as the other input. If both inputs are ordinal categorical arrays, they must have the same sets of categories, including their order. See “Compare Categorical Array Elements” for more details.</p> <p><b>B - Right array</b><br/>numeric array   logical array   character array   ordinal categorical array</p> <p>Right array, specified as a numeric array, logical array, character array, or categorical array. Inputs A and B must be the same size unless one</p> |

is a scalar. A scalar input expands into an array of the same size as the other input.

If one input is an ordinal categorical array, the other input can be an ordinal categorical array, a cell array of strings, or a single string. A single string expands into a cell array of strings of the same size as the other input. If both inputs are ordinal categorical arrays, they must have the same sets of categories, including their order. See “Compare Categorical Array Elements” for more details.

## Examples

### Test Vector Elements

Find which vector elements are greater than or equal to a given value.

Create a numeric vector.

```
A = [1 12 18 7 9 11 2 15];
```

Test the vector for elements that are greater than or equal to 11.

```
A >= 11
```

```
ans =
```

```
 0 1 1 0 0 1 0 1
```

The result is a vector with values of logical 1 (true) where the elements of A satisfy the expression.

Use the vector of logical values as an index to view the values in A that are greater than or equal to 11.

```
A(A >= 11)
```

```
ans =
```

```
 12 18 11 15
```

The result is a subset of the elements in A.

## Replace Elements of Matrix

Create a matrix.

```
A = magic(4)
```

```
A =
```

```
 16 2 3 13
 5 11 10 8
 9 7 6 12
 4 14 15 1
```

Replace all values greater than or equal to 9 with the value 10.

```
A(A >= 9) = 10
```

```
A =
```

```
 10 2 3 10
 5 10 10 8
 10 7 6 10
 4 10 10 1
```

The result is a new matrix whose largest element is 10.

## Compare Values in Categorical Array

Create an ordinal categorical array.

```
A = categorical({'large' 'medium' 'small'; 'medium' ...
 'small' 'large'},{'small' 'medium' 'large'},'Ordinal',1)
```

```
A =
```

```
 large medium small
 medium small large
```

The array has three categories: 'small', 'medium', and 'large'.

Find all values greater than or equal to the category 'medium'.

```
A >= 'medium'
```

```
ans =
```

```
 1 1 0
 1 0 1
```

A value of logical 1 (true) indicates a value greater than or equal to the category 'medium'.

Compare the rows of A.

```
A(1,:) >= A(2,:)
```

```
ans =
```

```
 1 1 0
```

The function returns logical 1 (true) where the first row has a category value greater than or equal to the second row.

## Test Complex Numbers

Create a vector of complex numbers.

```
A = [1+i 2-2i 1+3i 1-2i 5-i];
```

Find the values that are greater than or equal to 2.

```
A(A >= 2)
```

```
ans =
```

```
2.0000 - 2.0000i 5.0000 - 1.0000i
```

ge compares only the real part of the elements in A.

Use abs to find which elements are outside a radius of 2 from the origin.

```
A(abs(A) >= 2)
```

```
ans =
```

```
2.0000 - 2.0000i 1.0000 + 3.0000i 1.0000 - 2.0000i 5.0000 - 1.0000i
```

The result has more elements since `abs` accounts for the imaginary part of the numbers.

### Tips

- Some floating-point numbers cannot be represented exactly in binary form. This leads to small differences in results that the `>=` operator reflects. For more information, see “Avoiding Common Problems with Floating-Point Arithmetic”.

### See Also

`eq` | `lt` | `gt` | `le` | `ne`

### Concepts

- “Ordinal Categorical Arrays”

# genpath

---

**Purpose** Generate path string

**Syntax**  
`p = genpath`  
`p = genpath(folderName)`

**Description** `p = genpath` returns a path string, `p`, that includes all the folders and subfolders below `matlabroot/toolbox`, including empty subfolders.

`p = genpath(folderName)` returns a path string that includes `folderName` and multiple levels of subfolders below `folderName`. The path string does not include folders named `private`, folders that begin with the `@` character (class folders), folders that begin with the `+` character (package folders), or subfolders within any of these.

**Input Arguments** **folderName - Folder name**  
string

Folder name, specified as a string.

**Example:** `'c:/matlab/myfiles'`

**Examples** **Add Folder and Subfolders to Search Path**

Use `genpath` in conjunction with `addpath` to add a folder and its subfolders to the search path.

Generate a path that includes `matlabroot/toolbox/images/colorspaces` and all folders below it.

```
folderName = fullfile(matlabroot,'toolbox','images','colorspaces');
p = genpath(folderName);
```

Add the folder and its subfolders to the search path.

```
addpath(p)
```

**See Also** `addpath` | `path` | `rmpath`



**Concepts**

- “What Is the MATLAB Search Path?”

# genvarname

---

**Purpose** Construct valid variable name from string

---

**Note** `genvarname` will be removed in a future release. Use `matlab.lang.makeValidName` and `matlab.lang.makeUniqueStrings` instead.

---

**Syntax**

```
varname = genvarname(str)
varname = genvarname(str, exclusions)
```

**Description** `varname = genvarname(str)` constructs a string `varname` that is similar to or the same as the `str` input, and can be used as a valid variable name. `str` can be a single character array or a cell array of strings. If `str` is a cell array of strings, `genvarname` returns a cell array of strings in `varname`. The strings in a cell array returned by `genvarname` are guaranteed to be different from each other.

`varname = genvarname(str, exclusions)` returns a valid variable name that is different from any name listed in the `exclusions` input. The `exclusions` input can be a single character array or a cell array of strings. Specify the function `who` in the `exclusions` character array to create a variable name that will be unique in the current MATLAB workspace (see “Example 4” on page 1-2426, below).

---

**Note** `genvarname` returns a string that can be used as a variable name. It does not create a variable in the MATLAB workspace. You cannot, therefore, assign a value to the output of `genvarname`.

---

**Tips** A valid MATLAB variable name is a character string of letters, digits, and underscores, such that the first character is a letter, and the length of the string is less than or equal to the value returned by the `namelengthmax` function. Any string that exceeds `namelengthmax` is truncated in the `varname` output. See “Example 6” on page 1-2427, below.

The variable name returned by `genvarname` is not guaranteed to be different from other variable names currently in the MATLAB workspace unless you use the `exclusions` input in the manner shown in “Example 4” on page 1-2426, below.

If you use `genvarname` to generate a field name for a structure, MATLAB does create a variable for the structure and field in the MATLAB workspace. See “Example 3” on page 1-2426, below.

If the `str` input contains any whitespace characters, `genvarname` removes them and capitalizes the next alphabetic character in `str`. If `str` contains any nonalphanumeric characters, `genvarname` translates these characters into their hexadecimal value.

## Examples

### Example 1

Create four similar variable name strings that do not conflict with each other:

```
v = genvarname({'A', 'A', 'A', 'A'})
v =
 'A' 'A1' 'A2' 'A3'
```

### Example 2

Read a column header `hdr` from worksheet `trial2` in Excel spreadsheet `myproj_apr23`:

```
[data hdr] = xlsread('myproj_apr23.xls', 'trial2');
```

Make a variable name from the text of the column header that will not conflict with other names:

```
v = genvarname(['Column ' hdr{1,3}]);
```

Assign data taken from the spreadsheet to the variable in the MATLAB workspace:

```
eval([v '= data(1:7, 3);']);
```

## Example 3

Collect readings from an instrument once every minute over the period of an hour into different fields of a structure. Simulate instrument readings using a random number. `genvarname` not only generates unique fieldname strings, but also creates the structure and fields in the MATLAB workspace:

```
for k = 1:60
 record.(genvarname(['reading' datestr(clock, 'HHMMSS')])) = rand(1);
 pause(60)
end
```

After the program ends, display the recorded data from the workspace:

```
record

record =

 reading092610: 0.6541
 reading092710: 0.6892
 reading092811: 0.7482
 reading092911: 0.4505
 reading093011: 0.0838
 .
 .
 .
```

## Example 4

Generate variable names that are unique in the MATLAB workspace by putting the output from the `who` function in the `exclusions` list.

```
for k = 1:5
 t = clock;
 pause(uint8(rand * 10));
 v = genvarname('time_elapsed', who);
 eval([v ' = etime(clock,t)'])
end
```

As this code runs, you can see that the variables created by `genvarname` are unique in the workspace:

```
time_elapsed =
 5.0070
time_elapsed1 =
 2.0030
time_elapsed2 =
 7.0010
time_elapsed3 =
 8.0010
time_elapsed4 =
 3.0040
```

After the program completes, use the `who` function to view the workspace variables:

```
who

k time_elapsed time_elapsed2 time_elapsed4
t time_elapsed1 time_elapsed3 v
```

## Example 5

If you try to make a variable name from a MATLAB keyword, `genvarname` creates a variable name string that capitalizes the keyword and precedes it with the letter `x`:

```
v = genvarname('global')
v =
 xGlobal
```

## Example 6

If you enter a string that is longer than the value returned by the `namelengthmax` function, `genvarname` truncates the resulting variable name string:

```
namelengthmax
ans =
```

# genvarname

---

63

```
vstr = genvarname(sprintf('%s%s', ...
 'This name truncates because it contains ', ...
 'more than the maximum number of characters'))
vstr =
ThisNameTruncatesBecauseItContainsMoreThanTheMaximumNumberOfCha
```

## See Also

[isvarname](#) | [iskeyword](#) | [isletter](#) | [namelengthmax](#) | [who](#) | [regexp](#)

**Purpose** Query Handle Graphics object properties

**Syntax**

```

get(h)
get(h,'PropertyName')
<m-by-n value cell array> = get(H,pn)
a = get(h)
a = get(0)
a = get(0,'Factory')
a = get(0,'FactoryObjectTypePropertyName')
a = get(h,'Default')
a = get(h,'DefaultObjectTypePropertyName')

```

## Description

---

**Note** Do not use the `get` function on Java objects as it will cause a memory leak. For more information, see “Accessing Private and Public Data”

---

`get(h)` returns all properties of the graphics object identified by the handle `h` and their current values. For this syntax, `h` must be a scalar.

`get(h,'PropertyName')` returns the value of the property `'PropertyName'` of the graphics object identified by `h`.

`<m-by-n value cell array> = get(H,pn)` returns  $n$  property values for  $m$  graphics objects in the  $m$ -by- $n$  cell array, where  $m = \text{length}(H)$  and  $n$  is equal to the number of property names contained in `pn`.

`a = get(h)` returns a structure whose field names are the object's property names and whose values are the current values of the corresponding properties. If you do not specify an output argument, MATLAB displays the information on the screen. For this syntax, `h` may be a scalar or a  $m$ -by- $n$  array of handles. If `h` is a vector, `a` will be a  $(m*n)$ -by-1 struct array.

`a = get(0)` returns the current values of all user-settable properties. `a` is a structure array whose field names are the object property names and whose field values are the values of the corresponding properties.

If you do not specify an output argument, MATLAB displays the information on the screen.

`a = get(0, 'Factory')` returns the factory-defined values of all user-settable properties. `a` is a structure array whose field names are the object property names and whose field values are the values of the corresponding properties. If you do not specify an output argument, MATLAB displays the information on the screen.

`a = get(0, 'FactoryObjectTypePropertyName')` returns the factory-defined value of the named property for the specified object type. The argument *FactoryObjectTypePropertyName* is the word `Factory` concatenated with the object type (e.g., `Figure`) and the property name (e.g., `Color`)`FactoryFigureColor`.

`a = get(h, 'Default')` returns all default values currently defined on object `h`. `a` is a structure array whose field names are the object property names and whose field values are the values of the corresponding properties. If you do not specify an output argument, MATLAB displays the information on the screen.

`a = get(h, 'DefaultObjectTypePropertyName')` returns the factory-defined value of the named property for the specified object type. The argument *DefaultObjectTypePropertyName* is the word `Default` concatenated with the object type (e.g., `Figure`) and the property name (e.g., `Color`).

`DefaultFigureColor`

## Examples

You can obtain the default value of the `LineWidth` property for line graphics objects defined on the root level with the statement

```
get(0, 'DefaultLineLineWidth')
ans =
 0.5000
```

To query a set of properties on all axes children, define a cell array of property names:

```
props = {'HandleVisibility', 'Interruptible';
```



```
'SelectionHighlight', 'Type'};
output = get(get(gca, 'Children'), props);
```

The variable `output` is a cell array of dimension `length(get(gca, 'Children'))-by-4`.

For example, type

```
patch; surface; text; line
output = get(get(gca, 'Children'), props)
output =
 'on' 'on' 'on' 'line'
 'on' 'off' 'on' 'text'
 'on' 'on' 'on' 'surface'
 'on' 'on' 'on' 'patch'
```

## See Also

`findobj` | `gca` | `gcf` | `gco` | `set`

# audioplayer.get

---

**Purpose** Query property values for audioplayer object

**Syntax** *Value* = get(*obj*,*Name*)  
*Values* = get(*obj*,{*Name1*,...,*NameN*})  
*Values* = get(*obj*)  
get(*obj*)

**Description** *Value* = get(*obj*,*Name*) returns the value of the specified property for object *obj*.  
*Values* = get(*obj*,{*Name1*,...,*NameN*}) returns the values of the specified properties in a 1-by-*N* cell array.  
*Values* = get(*obj*) returns a scalar structure that contains the values of all properties of *obj*. Each field name corresponds to a property name.  
get(*obj*) displays all property names and their current values.

**Examples** Create an audioplayer object from the example file handel.mat and query the object properties:

```
load handel.mat;
handelObj = audioplayer(y, Fs);

% Display all properties.
get(handelObj)

% Display only the SampleRate property.
get(handelObj, 'SampleRate')

% Create a cell array that contains
% values for two properties.
info = get(handelObj, {'BitsPerSample', 'NumberOfChannels'});
```

**Alternatives** To access a single property, you can use dot notation. Reference each property as though it is a field of a structure array. For example, find the value of the TotalSamples property for an object named handelObj (as created in the Example):

```
numSamples = handelObj.TotalSamples;
```

This command is exactly equivalent to:

```
numSamples = get(handelObj, 'TotalSamples');
```

## **See Also**

[audioplayer | set](#)

# audiorecorder.get

---

**Purpose** Query property values for audiorecorder object

**Syntax**

```
Value = get(obj,Name)
Values = get(obj,{Name1,...,NameN})
Values = get(obj)
get(obj)
```

**Description**

*Value = get(obj,Name)* returns the value of the specified property for object *obj*.

*Values = get(obj,{Name1,...,NameN})* returns the values of the specified properties in a 1-by-*N* cell array.

*Values = get(obj)* returns a scalar structure that contains the values of all properties of *obj*. Each field name corresponds to a property name.

*get(obj)* displays all property names and their current values.

**Examples** Create an audiorecorder object and query the object properties:

```
recorderObj = audiorecorder;

% Display all properties.
get(recorderObj)

% Display only the SampleRate property.
get(recorderObj, 'SampleRate')

% Create a cell array that contains
% values for two properties.
info = get(recorderObj, {'BitsPerSample', 'NumberOfChannels'});
```

**Alternatives** To access a single property, you can use dot notation. Reference each property as though it is a field of a structure array. For example, find the value of the `TotalSamples` property for an object named `recorderObj` (as created in the Example):

```
numSamples = recorderObj.TotalSamples;
```

This command is exactly equivalent to:

```
numSamples = get(recorderObj, 'TotalSamples');
```

## See Also

[audiorecorder | set](#)

# get (COM)

---

**Purpose** Get property value from interface, or display properties

**Syntax**

```
V = h.get
V = h.get('propertyname')
V = get(h,...)
```

**Description** V = h.get returns a list of all properties and their values for the object or interface, h.

If V is empty, either there are no properties in the object, or the MATLAB software cannot read the object's type library. Refer to the COM vendor's documentation. For Automation objects, if the vendor provides documentation for a specific property, use the V = get(h,...) syntax to call it.

V = h.get('propertyname') returns the value of the property specified in the string, propertyname.

V = get(h,...) is an alternate syntax for the same operation.

**Tips** The meaning and type of the return value is dependent upon the specific property being retrieved. The object's documentation should describe the specific meaning of the return value. MATLAB may convert the data type of the return value. For a description of how MATLAB converts COM data types, see "Handling COM Data in MATLAB Software".

COM functions are available on Microsoft Windows systems only.

**Examples** Create a COM server running Microsoft Excel software:

```
e = actxserver ('Excel.Application');
```

Retrieve a single property value:

```
e.Path
```

Depending on your spreadsheet program, MATLAB software displays:

```
ans =
```

```
C:\Program Files\MSOffice\OFFICE11
```

Retrieve a list of all properties for the CommandBars interface:

```
c = e.CommandBars.get
```

MATLAB displays information similar to the following:

```
c =
 Application: [1x1
Interface.Microsoft_Excel_11.0_Object_Library._Application]
 Creator: 1.4808e+009
 ActionControl: []
 ActiveMenuBar: [1x1
Interface.Microsoft_Office_12.0_Object_Library.CommandBar]
 Count: 129
 DisplayTooltips: 1
 DisplayKeysInTooltips: 0
 LargeButtons: 0
 MenuAnimationStyle: 'msoMenuAnimationNone'
 Parent: [1x1
Interface.Microsoft_Excel_11.0_Object_Library._Application]
 AdaptiveMenus: 0
 DisplayFonts: 1
 DisableCustomize: 0
 DisableAskAQuestionDropdown: 0
```

## See Also

[set \(COM\)](#) | [inspect](#) | [isprop](#) | [addproperty](#) | [deletproperty](#)

# get (hgsetget)

---

**Purpose** Query property values of handle objects derived from hgsetget class

**Syntax** `CV = get(H, 'PropertyName')`  
`SV = get(h)`  
`get(h)`

**Description** `CV = get(H, 'PropertyName')` returns the value of the named property from the objects in the handle array H. If H is scalar, `get` returns a single value; if H is an array, `get` returns a cell array of property values. If you specify a cell array of property names, then `get` returns a cell array of values, where each row in the cell corresponds to an element in H and each column in the cell corresponds to an element in the property name cell array.

If H is nonscalar and `PropertyName` is the name of a dynamic property, `get` returns a value only if the property exists in all objects referenced in H.

`SV = get(h)` returns a struct array in which the field names are the object's property names and the values are the current values of the corresponding properties. If h is an array, then SV is a `numel(h)-by-1` array of structs.

`get(h)` displays all property names and their current values for the MATLAB objects with handle h.

Your subclass can override the hgsetget `getdisp` method to control how MATLAB displays this information.

**See Also** `get` | `handle` | `hgsetget` | `set (hgsetget)`

**How To**

- “Implementing a Set/Get Interface for Properties”



**Purpose**

Query property values for video reader object

**Syntax**

```
Value = get(obj,Name)
Values = get(obj,{Name1,...,NameN})
allValues = get(obj)
get(obj)
```

**Description**

`Value = get(obj,Name)` returns the value of the property with the specified `Name` for object `obj`.

`Values = get(obj,{Name1,...,NameN})` returns the values of the specified properties in a 1-by-N cell array.

`allValues = get(obj)` returns a scalar structure that contains the values of all properties of `Obj`. Each field name corresponds to a property name.

`get(obj)` displays all property names and their current values.

**Input Arguments****obj**

VideoReader object created by the VideoReader function.

**Name**

String enclosed in single quotation marks that specifies a VideoReader property.

**Output Arguments****Value**

String containing the value associated with the specified VideoReader property.

**Values**

Cell array containing the values associated with the specified VideoReader properties. `Values` is a row vector, with one column for each property.

**allValues**

# VideoReader.get

---

Scalar (1-by-1) structure array that contains the values of all properties of VideoReader object Obj.

## Examples

### Display All Object Properties

Display all properties of an object associated with the example file, xylophone.mp4.

```
xyloObj = VideoReader('xylophone.mp4');
get(xyloObj)
```

General Settings:

```
Duration = 4.7000
Name = xylophone.mp4
Path = matlabroot\toolbox\matlab\audiovideo
Tag =
Type = VideoReader
UserData = []
```

Video Settings:

```
BitsPerPixel = 24
FrameRate = 30
Height = 240
NumberOfFrames = 141
VideoFormat = RGB24
Width = 320
```

### Store Specific Object Properties

Create a 1-by-3 cell array that contains the values of the Height, Width, and NumberOfFrames properties of an object associated with xylophone.mp4.

```
xyloObj = VideoReader('xylophone.mp4');
xyloSize = get(xyloObj, {'Height', 'Width', 'NumberOfFrames'})
```

```
xyloSize =
```

```
 [240] [320] [141]
```

## Alternatives

To access a single property, you can use dot notation. Reference each property as though it is a field of a structure array. For example, find the value of the `NumberOfFrames` property for object `xyloObj` (as created in the Examples):

```
numFrames = xyloObj.NumberOfFrames;
```

This command is exactly equivalent to:

```
numFrames = get(xyloObj, 'NumberOfFrames');
```

## See Also

[VideoReader | set](#)

# get (RandStream)

---

**Purpose** Random stream properties

**Class** @RandStream

**Syntax**  
`get(s)`  
`P = get(s)`  
`P = get(s, 'PropertyName')`

**Description**  
`get(s)` prints the list of properties for the random stream `s`.  
`P = get(s)` returns all properties of `s` in a scalar structure.  
`P = get(s, 'PropertyName')` returns the property 'PropertyName'.

**See Also** RandStream | set (RandStream)

**Purpose** Serial port object properties

**Syntax**

```
get(obj)
out = get(obj)
out = get(obj, 'PropertyName')
```

**Description**

`get(obj)` returns all property names and their current values to the command line for the serial port object, `obj`.

`out = get(obj)` returns the structure `out` where each field name is the name of a property of `obj`, and each field contains the value of that property.

`out = get(obj, 'PropertyName')` returns the value `out` of the property specified by `PropertyName` for `obj`. If `PropertyName` is replaced by a 1-by-`n` or `n`-by-1 cell array of strings containing property names, then `get` returns a 1-by-`n` cell array of values to `out`. If `obj` is an array of serial port objects, then `out` will be a `m`-by-`n` cell array of property values where `m` is equal to the length of `obj` and `n` is equal to the number of properties specified.

**Tips** Refer to [Displaying Property Names and Property Values](#) for a list of serial port object properties that you can return with `get`.

When you specify a property name, you can do so without regard to case, and you can make use of property name completion. For example, if `s` is a serial port object, then these commands are all valid.

```
out = get(s, 'BaudRate');
out = get(s, 'baudrate');
out = get(s, 'BAUD');
```

**Examples** This example illustrates some of the ways you can use `get` to return property values for the serial port object `s` on a Windows platform.

```
s = serial('COM1');
out1 = get(s);
out2 = get(s, {'BaudRate', 'DataBits'});
```

## get (serial)

---

```
get(s, 'Parity')
```

```
ans =
none
```

### See Also

```
set
```

**Purpose** Query tscollection object property values

**Syntax** `value = get(tsc, 'PropertyName')`

**Description** `value = get(tsc, 'PropertyName')` returns the value of the specified property of the tscollection object tsc. The following syntax is equivalent:

`value = tsc.PropertyName`

`get(tsc)` displays all properties and values of the tscollection object tsc.

**See Also** `set (tscollection) | timeseries`

# getabstime (tscollection)

---

**Purpose** Extract date-string time vector into cell array

**Syntax** `getabstime(tsc)`

**Description** `getabstime(tsc)` extracts the time vector from the `tscollection` object `tsc` as a cell array of date strings. To define the time vector relative to a calendar date, set the `TimeInfo.StartDate` property of the time-series collection. When the `TimeInfo.StartDate` format is a valid `datestr` format, the output strings from `getabstime` have the same format.

**Examples** **1** Create a `tscollection` object.

```
tsc = tscollection(timeseries([3 6 8 0 10]));
```

**2** Set the `StartDate` property.

```
tsc.TimeInfo.StartDate = '10/27/2005 07:05:36';
```

**3** Extract a vector of absolute time values.

```
getabstime(tsc)
```

```
ans =
```

```
'27-Oct-2005 07:05:36'
'27-Oct-2005 07:05:37'
'27-Oct-2005 07:05:38'
'27-Oct-2005 07:05:39'
'27-Oct-2005 07:05:40'
```

**4** Change the date-string format of the time vector.

```
tsc.TimeInfo.Format = 'mm/dd/yy';
```

**5** Extract the time vector with the new date-string format.

```
getabstime(tsc)
```



```
ans =
 '10/27/05'
 '10/27/05'
 '10/27/05'
 '10/27/05'
 '10/27/05'
```

**See Also**      datestr | tscollection | setabstime (tscollection)

# getappdata

---

**Purpose** Value of application-defined data

**Syntax**  
`value = getappdata(h,name)`  
`values = getappdata(h)`

**Description** `value = getappdata(h,name)` returns the value of a MATLAB variable stored in a GUI. The first argument, `h`, is a handle to the component that is associated with the data. The second argument, `name`, is a string that identifies the name of the data. The values of `h` and `name` must match those passed to `setappdata` when you store the data.

`values = getappdata(h)` returns all variable data associated with the component having the handle, `h`.

---

**Note** `h` can be a handle to any GUI component except an ActiveX component.

---

**See Also** `setappdata` | `isappdata` | `rmappdata`

**Concepts**

- “Share Data Among Callbacks”

**Purpose** Store recorded audio signal in numeric array

**Syntax**  
`y = getaudiodata(recorder)`  
`y = getaudiodata(recorder, dataType)`

**Description** `y = getaudiodata(recorder)` returns recorded audio data associated with `audiorecorder` object `recorder` to double array `y`.

`y = getaudiodata(recorder, dataType)` converts the signal data to the specified data type: 'double', 'single', 'int16', 'int8', or 'uint8'.

**Output Arguments**

**y**  
Audio signal data `y` contains the same number of columns as the number of channels in the recording: one for mono, two for stereo. The range of values depends on the data type, as shown in the following table.

| Data Type | Sample Value Range |
|-----------|--------------------|
| int8      | -128 to 127        |
| uint8     | 0 to 255           |
| int16     | -32768 to 32767    |
| single    | -1 to 1            |
| double    | -1 to 1            |

**Examples** Collect a sample of your speech with a microphone, and plot the signal data:

```
% Record your voice for 5 seconds.
recObj = audiorecorder;
disp('Start speaking.')
```

```
recordblocking(recObj, 5);
disp('End of Recording.');
```

# audiorecorder.getaudiodata

---

```
% Play back the recording.
play(recObj);

% Store data in double-precision array.
myRecording = getaudiodata(recObj);

% Plot the waveform.
plot(myRecording);
```

## See Also

audiorecorder

## How To

- “Characteristics of Audio Files”
- “Record Audio”

**Purpose** Character array from Automation server

**Syntax** **IDL Method Signature**

```
HRESULT GetCharArray([in] BSTR varName, [in] BSTR Workspace, [out, retval] BSTR str);
```

**Microsoft Visual Basic Client**

```
GetCharArray(varname As String, workspace As String) As String
```

**MATLAB Client**

```
str = h.GetCharArray('varname', 'workspace')
str = GetCharArray(h, 'varname', 'workspace')
```

**Description**

`str = h.GetCharArray('varname', 'workspace')` gets the character array stored in `varname` from the specified workspace of the server attached to handle `h` and returns it in `str`. The values for `workspace` are `base` or `global`.

`str = GetCharArray(h, 'varname', 'workspace')` is an alternate syntax.

**Examples**

This example uses a Visual Basic .NET client.

- 1 Create the Visual Basic application. Use the `MsgBox` command to control flow between MATLAB and the application.

```
Dim Matlab As Object
Dim S As String
Matlab = CreateObject("matlab.application")
MsgBox("In MATLAB, type" & vbCrLf _
& "str='new string';")
```

- 2 Open the MATLAB window, then type:

```
str='new string';
```

- 3 Click **Ok**.

Try

# GetCharArray

---

```
S = Matlab.GetCharArray("str", "base")
MsgBox("str = " & S)
Catch ex As Exception
 MsgBox("You did not set 'str' in MATLAB")
End Try
```

The Visual Basic MsgBox displays what you typed in MATLAB.

## See Also

[PutCharArray](#) | [GetWorkspaceData](#) | [GetVariable](#)

|                    |                                                                                                                                                                                                                                                                                          |
|--------------------|------------------------------------------------------------------------------------------------------------------------------------------------------------------------------------------------------------------------------------------------------------------------------------------|
| <b>Purpose</b>     | Override to change command window display                                                                                                                                                                                                                                                |
| <b>Syntax</b>      | getdisp(H)                                                                                                                                                                                                                                                                               |
| <b>Description</b> | getdisp(H) called by <code>get</code> when <code>get</code> is called with no output arguments and a single input argument that is a handle array. Override this <code>hgsetget</code> class method in a subclass to change how property information is displayed in the command window. |
| <b>See Also</b>    | <code>hgsetget</code>   <code>get</code> ( <code>hgsetget</code> )                                                                                                                                                                                                                       |
| <b>How To</b>      | <ul style="list-style-type: none"><li>• “Implementing a Set/Get Interface for Properties”</li></ul>                                                                                                                                                                                      |

# getenv

---

**Purpose** Environment variable

**Syntax** `getenv 'name'`  
`N = getenv('name')`

**Description** `getenv 'name'` searches the underlying operating system's environment list for a string of the form `name=value`, where `name` is the input string. If found, MATLAB returns the string value. If the specified name cannot be found, an empty matrix is returned.

On UNIX platforms, the shell you use to launch MATLAB determines the operating system environment. For example, starting MATLAB on a Macintosh platform from the Applications folder creates a different shell environment from launching MATLAB from Terminal.

`N = getenv('name')` returns value to the variable `N`.

**Examples** `os = getenv('OS')`

```
os =
Windows_NT
```

**See Also** `setenv` | `computer` | `pwd` | `ver` | `path`



|                    |                                                                                                                                                                                                                                                                                                                                                                                                                                                                                                                                                                                                                                                                                                                                                                                                                                                                                                                                                                                                         |
|--------------------|---------------------------------------------------------------------------------------------------------------------------------------------------------------------------------------------------------------------------------------------------------------------------------------------------------------------------------------------------------------------------------------------------------------------------------------------------------------------------------------------------------------------------------------------------------------------------------------------------------------------------------------------------------------------------------------------------------------------------------------------------------------------------------------------------------------------------------------------------------------------------------------------------------------------------------------------------------------------------------------------------------|
| <b>Purpose</b>     | Field of structure array                                                                                                                                                                                                                                                                                                                                                                                                                                                                                                                                                                                                                                                                                                                                                                                                                                                                                                                                                                                |
| <b>Syntax</b>      | <pre>value = getfield(struct, 'field') value = getfield(struct, {sIndx1, ..., sIndxM}, 'field', {fIndx1, ..., fIndxN})</pre>                                                                                                                                                                                                                                                                                                                                                                                                                                                                                                                                                                                                                                                                                                                                                                                                                                                                            |
| <b>Description</b> | <p><code>value = getfield(struct, 'field')</code>, where <code>struct</code> is a 1-by-1 structure, returns the contents of the specified field, equivalent to <code>value = struct.field</code>. Pass field references as strings.</p> <p><code>value = getfield(struct, {sIndx1, ..., sIndxM}, 'field', {fIndx1, ..., fIndxN})</code> returns the contents of the specified field, equivalent to <code>value = struct(sIndx1, ..., sIndxM).field(fIndx1, ..., fIndxN)</code>. The <code>getfield</code> function supports multiple sets of <code>field</code> and <code>fIndx</code> inputs, and all <code>Indx</code> inputs are optional. If structure <code>struct</code> or any of the fields is a nonscalar structure, and you do not specify an <code>Indx</code>, the <code>getfield</code> function returns the values associated with the first index. If you specify a single colon operator for an <code>fIndx</code> input, enclose it in single quotation marks: <code>' : '</code>.</p> |
| <b>Tips</b>        | <ul style="list-style-type: none"><li>• For most cases, retrieve data from a structure array by indexing rather than using the <code>getfield</code> function. For more information, see “Access Data in a Structure Array” and “Generate Field Names from Variables”.</li><li>• Call <code>getfield</code> to simplify references to structure arrays with nested fields, or to avoid creating unnecessary temporary variables, as shown in the Examples section.</li></ul>                                                                                                                                                                                                                                                                                                                                                                                                                                                                                                                            |
| <b>Examples</b>    | <p>The what function returns a structure array that describes the MATLAB files in the current folder. Find the files with the <code>.m</code> extension:</p> <pre>files = getfield(what, 'm');</pre> <p>To perform the same task by indexing requires that you create a temporary variable:</p>                                                                                                                                                                                                                                                                                                                                                                                                                                                                                                                                                                                                                                                                                                         |

```
templist = what;
files = templist.m;
```

---

Find values within a structure that contains nested fields:

```
level = 5;
semester = 'Fall';
subject = 'Math';
student = 'John_Doe';
fieldnames = {semester subject student};

% Add data to a structure named grades.
grades(level).(semester).(subject).(student)(10,21:30) = ...
 [85, 89, 76, 93, 85, 91, 68, 84, 95, 73];

% Retrieve the data added.
getfield(grades, {level}, fieldnames{:}, {10,21:30})
```

---

Using the structure defined in the previous example, find all values in the tenth row of the specified field:

```
getfield(grades, {level}, fieldnames{:}, {10,':'})
```

## See Also

[setfield](#) | [fieldnames](#) | [isfield](#) | [orderfields](#) | [rmfield](#)

## How To

- “Generate Field Names from Variables”
- “Access Data in a Structure Array”

**Purpose** File formats that VideoReader supports

**Syntax** `formats = VideoReader.getFileFormats()`

**Description** `formats = VideoReader.getFileFormats()` returns an array of `audiovideo.FileFormatInfo` objects that indicate which formats VideoReader can read on the current system. Each object has the following properties: `Extension`, `Description`, `ContainsVideo`, and `ContainsAudio`.

- Tips**
- On Windows and UNIX systems, the list of file formats does not always contain all the formats that VideoReader can read on your system. `getFileFormats` returns a platform-dependent, static list of formats that VideoReader can read on most systems.
  - On all systems, VideoReader cannot always read a particular video file even if `getFileFormats` lists its format. For more information, see Supported Video File Formats.

## Output Arguments

### **formats**

Array of `audiovideo.FileFormatInfo` objects, which have the following properties:

|                            |                                                      |
|----------------------------|------------------------------------------------------|
| <code>Extension</code>     | File extension.                                      |
| <code>Description</code>   | Text description of the file format.                 |
| <code>ContainsVideo</code> | Whether VideoReader can read video from this format. |
| <code>ContainsAudio</code> | Whether VideoReader can read audio from this format. |

To convert this array to a filter list for dialog boxes generated with `uigetfile`, use the `getFilterSpec` method with the following syntax:

# VideoReader.getFileFormats

---

```
filterSpec = getFilterSpec(formats)
```

The filter list includes 'All Video Files' in the first row of the cell array, and 'All Files (\*.\*)' in the last row.

## Examples

View the list of file formats that VideoReader supports on your system:

```
VideoReader.getFileFormats()
```

On a Windows system, this list appears as follows:

```
Video File Formats:
 .asf - ASF File
 .asx - ASX File
 .avi - AVI File
 .mj2 - Motion JPEG2000
 .mpg - MPEG-1
 .wmv - Windows Media Video
```

---

Create a dialog box to select a video file:

```
% Get the supported file formats.
formats = VideoReader.getFileFormats();

% Convert to a filter list.
filterSpec = getFilterSpec(formats);

% Create the dialog box.
[filename, pathname] = uigetfile(filterSpec);
```

---

Check whether VideoReader can read an .avi file on the current system:

```
fmtList = VideoReader.getFileFormats();
```

```
if any(ismember({fmtList.Extension},'avi'))
 disp('VideoReader can read AVI files on this system.');
```

else

```
 disp('VideoReader cannot read AVI files on this system.');
```

end

## See Also

VideoReader

# getframe

---

**Purpose** Capture movie frame

**Syntax**

```
getframe
F = getframe
F = getframe(h)
F = getframe(h,rect)
```

**Description** `getframe` returns a movie frame. The frame is a snapshot (pixmap) of the current axes or figure.

`F = getframe` gets a frame from the current axes.

`F = getframe(h)` gets a frame from the figure or axes identified by handle `h`.

`F = getframe(h,rect)` specifies a rectangular area from which to copy the pixmap. `rect` is relative to the lower left corner of the figure or axes `h`, in pixel units. `rect` is a four-element vector in the form `[left bottom width height]`, where `width` and `height` define the dimensions of the rectangle.

`getframe` returns a movie frame, which is a structure having two fields:

- `cdata` — The image data stored as a matrix of `uint8` values. The dimensions of `F.cdata` are height-by-width-by-3.
- `colormap` — The colormap stored as an `n-by-3` matrix of doubles. `F.colormap` is empty on true color systems.

To capture an image, use this approach:

```
F = getframe(gcf);
image(F.cdata)
colormap(F.colormap)
```

**Tips** `getframe` is usually used in a `for` loop to assemble an array of movie frames for playback using `movie`. For example,

```
for j = 1:n
 plotting commands
 F(j) = getframe;
```

```
end
movie(F)
```

If you are capturing frames of a plot that takes a long time to generate or are repeatedly calling `getframe` in a loop, make sure that your computer's screen saver does not activate and that your monitor does not turn off for the duration of the capture; otherwise one or more of the captured frames can contain graphics from your screen saver or nothing at all.

---

**Note** In situations where MATLAB software is running on a virtual desktop that is not currently visible on your monitor, calls to `getframe` will complete, but will capture a region on your monitor that corresponds to the position occupied by the figure or axes on the hidden desktop. Therefore, make sure that the window to be captured by `getframe` exists on the currently active desktop.

---

### Capture Regions

`F = getframe` returns the contents of the current axes, exclusive of the axis labels, title, or tick labels.

`F = getframe(gcf)` captures the entire interior of the current figure window.

To capture the figure window menu, use `F = getframe(h,rect)` with a rectangle sized to include the menu.

### Resolution of Captured Frames

The resolution of the framed image depends on the size of the axes in pixels when `getframe` is called. As the `getframe` command takes a snapshot of the screen, if the axes is small in size (e.g., because you have restricted the view to a window within the axes), `getframe` captures fewer screen pixels, and the captured image might have poor resolution if enlarged for display.

## Capturing UIControls

To capture uicontrols along with the axes and any annotations displayed on the plot, specify the figure handle:

```
F = getframe(figure_handle);
```

To exclude uicontrols outside of the current axes, do not specify the figure handle:

```
F = getframe;
```

## Limitations with Renderer on Windows Systems

Setting the figure `Renderer` property to `zbuffer` or `painters` works around limitations of using `getframe` with the OpenGL renderer on some Windows systems.

## Examples

Make the peaks function vibrate.

```
Z = peaks;
figure('Renderer','zbuffer');
surf(Z);
axis tight manual;
set(gca,'NextPlot','replaceChildren');
for j = 1:20
 surf(sin(2*pi*j/20)*Z,Z)
 F(j) = getframe;
end
movie(F,20) % Play the movie twenty times
```

The fifth frame of the sequence looks like this.



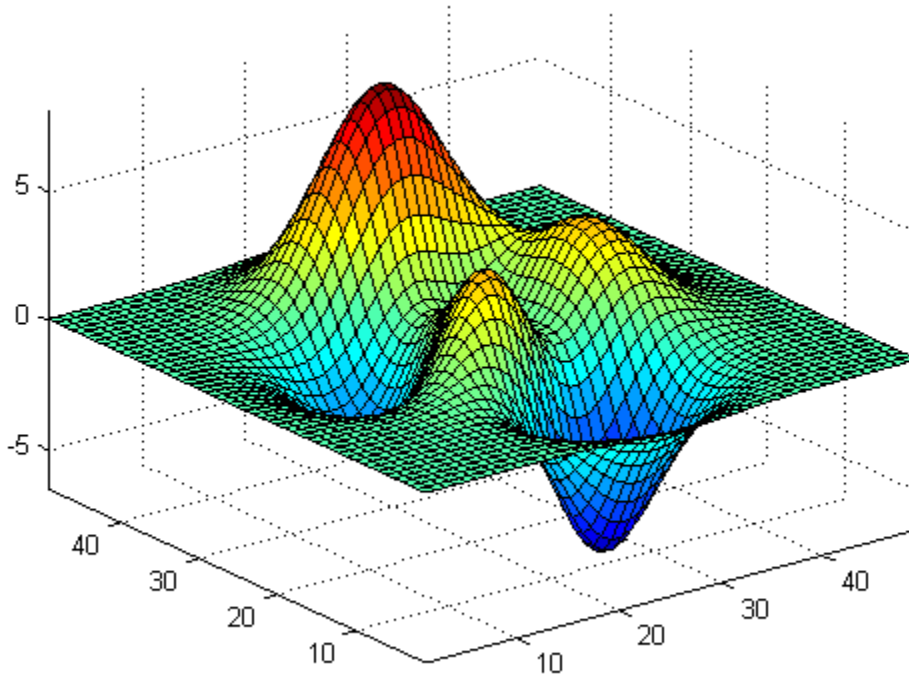

**See Also**

[axis](#) | [frame2im](#) | [gcf](#) | [image](#) | [im2frame](#) | [movie](#)

# GetFullMatrix

---

**Purpose** Matrix from Automation server workspace

**Syntax** **IDL Method Signature**

```
GetFullMatrix([in] BSTR varname, [in] BSTR
workspace, [in, out] SAFEARRAY(double) *pr, [in,
out] SAFEARRAY(double) *pi)
```

## Microsoft Visual Basic Client

```
GetFullMatrix(varname As String, workspace As String,
[out] XReal As Double, [out] XImag As Double)
```

## MATLAB Client

```
[xreal ximag] =
h.GetFullMatrix('varname', 'workspace', zreal, zimag)
[xreal ximag] =
GetFullMatrix(h, 'varname', 'workspace', zreal, zimag)
```

**Description**

[xreal ximag] =  
h.GetFullMatrix('varname', 'workspace', zreal, zimag) gets  
matrix stored in variable varname from the specified workspace of the  
server attached to handle h. The function returns the real  
part in xreal and the imaginary part in ximag. The values  
for *workspace* are base or global.

```
[xreal ximag] =
GetFullMatrix(h, 'varname', 'workspace', zreal, zimag) is an
alternate syntax.
```

The zreal and zimag arguments are matrices of the same size as the  
real and imaginary matrices (xreal and ximag) returned from the  
server. The zreal and zimag matrices are commonly set to zero.

Use GetFullMatrix for values of type double only. Use GetVariable or  
GetWorkspaceData for other types.

For VBScript clients, use the GetWorkspaceData and PutWorkspaceData  
functions to pass numeric data to and from the MATLAB workspace.  
These functions use the variant data type instead of the safearray

data type used by `GetFullMatrix` and `PutFullMatrix`. VBScript does not support `safearray`.

## Examples

This example uses a Visual Basic .NET client to read data from a MATLAB Automation server:

- 1 Create the Visual Basic application. Use the `MsgBox` command to control flow between MATLAB and the application.

```
Dim MatLab As Object
Dim Result As String
Dim XReal(4, 4) As Double
Dim XImag(4, 4) As Double
Dim i, j As Integer

MatLab = CreateObject("matlab.application")
Result = MatLab.Execute("M = rand(5);")
MsgBox("In MATLAB, type" & vbCrLf _
 & "M(3,4)")
```

- 2 Open the MATLAB window and type:

```
M(3,4)
```

- 3 Click **Ok**.

- 4 In the Visual Basic application:

```
MatLab.GetFullMatrix("M", "base", XReal, XImag)
i = 2 %0-based array
j = 3

MsgBox("XReal(" & i + 1 & "," & j + 1 & ") " & _
 " = " & XReal(i, j))
```

- 5 Click **Ok** to close and terminate MATLAB.

## See Also

`PutFullMatrix` | `GetVariable` | `GetWorkspaceData` | `Execute`

# GetFullMatrix

---

## How To

- “Exchanging Data with the Server”

## Purpose

Get component position in pixels

## Syntax

```
position = getpixelposition(handle)
position = getpixelposition(handle,recursive)
```

## Description

`position = getpixelposition(handle)` gets the position, in pixel units, of the component with handle `handle`. MATLAB returns the position as a four-element vector that specifies the location and size of the component: [distance from left, distance from bottom, width, height].

`position = getpixelposition(handle,recursive)` gets the position as above. If `recursive` is true, the returned position is relative to the parent figure of `handle`.

Use the `getpixelposition` function only to obtain coordinates for children of figures and container components (uipanel, or uibuttongroups). Results are not reliable for children of axes or other Handle Graphics objects.

## Examples

This example creates a push button within a panel, and then retrieves its position, in pixels, relative to the *panel*.

```
f = figure('Position',[300 300 300 200]);
p = uipanel('Position',[.2 .2 .6 .6]);
h1 = uicontrol(p,'Style','PushButton',...
 'Units','Normalized',...
 'String','Push Button',...
 'Position',[.1 .1 .5 .2]);
drawnow;
pos1 = getpixelposition(h1)
```

```
pos1 =
 18.6000 12.6000 88.0000 23.2000
```

# getpixelposition

---

The following statement retrieves the position of the push button, in pixels, relative to the *figure*.

```
pos1 = getpixelposition(h1,true)

pos1 =
 78.6000 52.6000 88.0000 23.2000
```

## See Also

[setpixelposition](#) | [uicontrol](#) | [uipanel](#)

**Purpose**

Preference

**Syntax**

```
getpref('group','pref')
getpref('group','pref',default)
getpref('group',{'pref1','pref2',... 'prefn'})
getpref('group',{'pref1',... 'prefn'},{default1,...defaultn})
getpref('group')
getpref
```

**Description**

`getpref('group','pref')` returns the value for the preference specified by `group` and `pref`. It is an error to get a preference that does not exist.

`group` labels a related collection of preferences. You can choose any name that is a legal variable name, and is descriptive enough to be unique, e.g. 'ApplicationOnePrefs'. The input argument `pref` identifies an individual preference in that group, and must be a legal variable name.

`getpref('group','pref',default)` returns the current value if the preference specified by `group` and `pref` exists. Otherwise creates the preference with the specified default value and returns that value.

`getpref('group',{'pref1','pref2',... 'prefn'})` returns a cell array containing the values for the preferences specified by `group` and the cell array of preference names. The return value is the same size as the input cell array. It is an error if any of the preferences do not exist.

`getpref('group',{'pref1',... 'prefn'},{default1,...defaultn})` returns a cell array with the current values of the preferences specified by `group` and the cell array of preference names. Any preference that does not exist is created with the specified default value and returned.

`getpref('group')` returns the names and values of all preferences in the group as a structure.

`getpref` returns all groups and preferences as a structure.

---

**Note** Preference values are persistent and maintain their values between MATLAB sessions. Where they are stored is system dependent.

---

## Examples

### Get the Value of an Existing Preference

```
addpref('mytoolbox','version','1.0')
getpref('mytoolbox','version')
```

```
ans =
 1.0
```

### Create a Preference Using Specified Default Value

```
setpref('mytoolbox','version','1.0')
rmpref('mytoolbox','version')
getpref('mytoolbox','version','1.0');
getpref('mytoolbox','version')
```

```
ans =

1.0
```

The first call to `getpref` adds the `'version'` preference and sets its value to the default value, `1.0`. The second call to `getpref` verifies that the preference exists, and that its value is `1.0`.

## See Also

`addpref` | `ispref` | `rmpref` | `setpref` | `uigetpref` | `uisetpref`



**Purpose** List profiles and file formats supported by VideoWriter

**Syntax** `profiles = VideoWriter.getProfiles()`

**Description** `profiles = VideoWriter.getProfiles()` returns an array of `audiovideo.writer.ProfileInfo` objects that indicate the types of files VideoWriter can create.

**Output Arguments**

**profiles**

An array of `audiovideo.writer.ProfileInfo` objects, which have the following read-only properties:

|                               |                                                                                                                                                                                                                                    |
|-------------------------------|------------------------------------------------------------------------------------------------------------------------------------------------------------------------------------------------------------------------------------|
| <code>Name</code>             | String profile name, such as 'Uncompressed AVI'.                                                                                                                                                                                   |
| <code>Description</code>      | String description of the profile.                                                                                                                                                                                                 |
| <code>FileExtensions</code>   | Cell array of strings containing file extensions supported by the file format.                                                                                                                                                     |
| <code>ColorChannels</code>    | Number of color channels in each output video frame.                                                                                                                                                                               |
| <code>CompressionRatio</code> | Number greater than 1 that specifies the target ratio between the number of bytes in the input image and the number of bytes in the compressed image. Only applies to objects associated with Motion JPEG 2000 files. Default: 10. |
| <code>FrameRate</code>        | Rate of playback for the video in frames per second. Default: 30.                                                                                                                                                                  |

# VideoWriter.getProfiles

---

|                        |                                                                                                                                                                                                                                                                                |
|------------------------|--------------------------------------------------------------------------------------------------------------------------------------------------------------------------------------------------------------------------------------------------------------------------------|
| LosslessCompression    | Boolean value (logical true or false) that specifies whether to use reversible mode, so that the decompressed data is identical to the input data. When true, VideoWriter ignores values for CompressionRatio. Only applies to objects associated with Motion JPEG 2000 files. |
| MJ2BitDepth            | Number of least significant bits in the input image data, from 1 to 16. Only applies to objects associated with Motion JPEG 2000 files.                                                                                                                                        |
| Quality                | Number from 0 through 100. Higher values correspond to higher quality video and larger files. Only applies to objects associated with the MPEG-4 or Motion JPEG AVI profile. Default: 75.                                                                                      |
| VideoBitsPerPixel      | Number of bits per pixel in each output video frame.                                                                                                                                                                                                                           |
| VideoCompressionMethod | String indicating the type of video compression, such as 'None' or 'Motion JPEG'.                                                                                                                                                                                              |
| VideoFormat            | String indicating the MATLAB representation of the video format, such as 'RGB24'.                                                                                                                                                                                              |

## Examples

### Profile Information

View the list of available profiles and specific information about the 'Uncompressed AVI' profile.

```
profiles = VideoWriter.getProfiles()

uncompAVI = find(ismember({profiles.Name}, 'Uncompressed AVI'));
profiles(uncompAVI)
```

`profiles(uncompAVI).FileExtensions`

## **See Also**

`VideoWriter`

# getReport (MException)

---

**Purpose** Get error message for exception

**Syntax**

```
msgString = getReport(exception)
msgString = getReport(exception, type)
msgString = getReport(exception, type, 'hyperlinks', value)
```

**Description** `msgString = getReport(exception)` returns a formatted message string, `msgString`, from an exception. This exception is represented by the `exception` input which is a scalar object of the `MException` class. The message string returned by `getReport` is the same as the error message displayed by MATLAB when it throws this exception.

`msgString = getReport(exception, type)` returns a message string that either describes just the error (**basic** type), or shows the error and the stack as well (**extended** type). The `type` argument, when used, must be the second argument in the input argument list. See “Examples” on page 1-2475 , below.

| type Option | Displayed Text                                                            |
|-------------|---------------------------------------------------------------------------|
| 'extended'  | Display line number, error message, and cause and stack summary (default) |
| 'basic'     | Display line number and error message                                     |

`msgString = getReport(exception, type, 'hyperlinks', value)` returns a message string that either does or does not include active hyperlinks to the failing lines in the code. See the table below for the valid choices for `value`. The **hyperlinks** and `value` arguments, when used, must be the third and fourth arguments in the input argument list.

| value Option | Action                                                                                                    |
|--------------|-----------------------------------------------------------------------------------------------------------|
| 'on'         | Display hyperlinks to failing lines (default)                                                             |
| 'off'        | Do not display hyperlinks to failing lines                                                                |
| 'default'    | Use the default for the Command Window to determine whether or not to use hyperlinks in the error message |

## Examples

This function attempts to read from a file that does not exist. When you call it, pass either 'basic' or 'extended' to specify the type of report you want to see displayed:

```
function line = test_getreport(file, rpttype)
try
 line = read_file(file);
catch exc
 getReport(exc, rpttype)
end

function line = read_file(file)
 fid = fopen(file, 'r');
 line = fread(fid);
```

The basic option displays only the error message:

```
test_getreport('filethatdoesnotexist.txt', 'basic')
ans =
```

Error using fread

Invalid file identifier. Use fopen to generate a valid file identifier.

The extended option displays the error message and error call stack:

```
test_getreport('filethatdoesnotexist.txt', 'extended')
ans =
```

## getReport (MException)

---

Error using fread

Invalid file identifier. Use fopen to generate a valid file identifier.

Error in test\_getreport>read\_file (line 10)

```
line = fread(fid);
```

Error in test\_getreport (line 3)

```
line = read_file(file);
```

### See Also

```
last(MException) | addCause(MException) |
throwAsCaller(MException) | rethrow(MException) |
throw(MException) | MException | assert | error | try, catch
```

# getsampleusingtime (tscollection)

---

**Purpose**

Extract data samples into new tscollection object

**Syntax**

```
tsc2 = getsampleusingtime(tsc1,Time)
tsc2 = getsampleusingtime(tsc1,StartTime,EndTime)
```

**Description**

tsc2 = getsampleusingtime(tsc1,Time) returns a new tscollection tsc2 with a single sample corresponding to Time in tsc1.

tsc2 = getsampleusingtime(tsc1,StartTime,EndTime) returns a new tscollection tsc2 with samples between the times StartTime and EndTime in tsc1.

**Tips**

When the time vector in ts1 is numeric, StartTime and EndTime must also be numeric. When the times in ts1 are date strings and the StartTime and EndTime values are numeric, then the StartTime and EndTime values are treated as datenum values.

**See Also**

tscollection

# Tiff.getTag

---

**Purpose** Value of specified tag

**Syntax** `tagValue = getTag(tagId)`

**Description** `tagValue = getTag(tagId)` retrieves the value of the TIFF tag specified by `tagId`. You can specify `tagId` as a character string ('ImageWidth') or using the numeric tag identifier defined by the TIFF specification (256). To see a list of all the tags with their numeric identifiers, view the value of the Tiff object `TagID` property. Use the `TagID` property to specify the value of a tag. For example, `Tiff.TagID.ImageWidth` is equivalent to the tag's numeric identifier.

## Examples **Get Value of Tag**

Open a Tiff object and get the value of a tag. Specify the tag by name.

```
t = Tiff('example.tif', 'r');
tagval = t.getTag('ImageWidth')
```

```
tagval =
```

```
600
```

Alternatively, specify the tag by numeric identifier.

```
tagval1 = t.getTag(256)
```

```
tagval1 =
```

```
600
```

Another way to specify the numeric identifier is to use the `TagID` property.

```
tagval2 = t.getTag(Tiff.TagID.ImageWidth)
```

```
tagval2 =
```



600

Close the Tiff object.

```
t.close();
```

## References

This method corresponds to the `TIFFGetField` function in the LibTIFF C API. To use this method, you must be familiar with the TIFF specification and technical notes. View this documentation at [LibTiff - TIFF Library and Utilities](#).

## See Also

`Tiff.setTag`

## Tutorials

- “Exporting Image Data and Metadata to TIFF Files”
- “Reading Image Data and Metadata from TIFF Files”

# Tiff.getTagNames

---

**Purpose** List of recognized TIFF tags

**Syntax** `tagNames = Tiff.getTagNames()`

**Description** `tagNames = Tiff.getTagNames()` returns a cell array of TIFF tags recognized by the `Tiff` object.

**Examples** Retrieve a list of TIFF tags recognized by the `Tiff` object.

```
Tiff.getTagNames

ans =

 'SubFileType'
 'ImageWidth'
 'ImageLength'
 'BitsPerSample'
 'Compression'
 'Photometric'
 'Thresholding'
 'FillOrder'
 'DocumentName'
 'ImageDescription'
 .
 .
 .
```

**See Also** `Tiff.getTag`

**Tutorials**

- “Exporting Image Data and Metadata to TIFF Files”
- “Reading Image Data and Metadata from TIFF Files”

**Purpose** Cell array of names of timeseries objects in tscollection object

**Syntax** `names = gettimeseriesnames(tsc)`

**Description** `names = gettimeseriesnames(tsc)` returns names of timeseries objects in a tscollection object tsc. names is a cell array of strings.

**Examples** **1** Create timeseries objects a and b.

```
a = timeseries(rand(1000,1),'name','position');
b = timeseries(rand(1000,1),'name','response');
```

**2** Create a tscollection object that includes these two time series.

```
tsc = tscollection({a,b});
```

**3** Get the names of the timeseries objects in tsc.

```
names = gettimeseriesnames(tsc)
```

```
names =
```

```
 'position' 'response'
```

**See Also** `timeseries` | `tscollection`

# gettsafteratevent

---

**Purpose** New timeseries object with samples occurring at or after event

**Syntax**  
`ts1 = gettsafteratevent(ts,event)`  
`ts1 = gettsafteratevent(ts,event,n)`

**Description** `ts1 = gettsafteratevent(ts,event)` returns a new `timeseries` object `ts1` with samples occurring at and after an event in `ts`, where `event` can be either a `tsdata.event` object or a string. When `event` is a `tsdata.event` object, the time defined by `event` is used. When `event` is a string, the first `tsdata.event` object in the `Events` property of the time series `ts` that matches the event name specifies the time.

`ts1 = gettsafteratevent(ts,event,n)` returns a new `timeseries` object `ts1` with samples at and after an event in `ts`, where `n` is the number of the event occurrence with a matching event name.

**Tips** When the `timeseries` object `ts` contains date strings and `event` uses numeric time, the time selected by the `event` is treated as a date that is calculated relative to the `StartDate` property in `ts.TimeInfo`.

When `ts` uses numeric time and `event` uses calendar dates, the time selected by the `event` is treated as a numeric value that is not associated with a calendar date.

**See Also** `gettsafterevent` | `gettsbeforeevent` | `gettsbetweenevents` | `tsdata.event` | `timeseries`

**Purpose** New timeseries object with samples occurring after event

**Syntax**

```
ts1 = gettsafterevent(ts,event)
ts1 = ttsafterevent(ts,event,n)
```

**Description** `ts1 = gettsafterevent(ts,event)` returns a new `timeseries` object `ts1` with samples occurring after an event in `ts`, where `event` can be either a `tsdata.event` object or a string. When `event` is a `tsdata.event` object, the time defined by `event` is used. When `event` is a string, the first `tsdata.event` object in the `Events` property of `ts` that matches the event name specifies the time.

`ts1 = ttsafterevent(ts,event,n)` returns a new `timeseries` object `ts1` with samples occurring after an event in time series `ts`, where `n` is the number of the event occurrence with a matching event name.

**Tips** When the `timeseries` object `ts` contains date strings and `event` uses numeric time, the time selected by the event is treated as a date that is calculated relative to the `StartDate` property in `ts.TimeInfo`.

When `ts` uses numeric time and `event` uses calendar dates, the time selected by the event is treated as a numeric value that is not associated with a calendar date.

**See Also** `gettsafteratevent` | `gettsbeforeevent` | `gettsbetweenevents` | `timeseries` | `tsdata.event`

# gettsatevent

---

**Purpose** New timeseries object with samples occurring at event

**Syntax**  
`ts1 = gettsatevent(ts,event)`  
`ts1 = gettsatevent(ts,event,n)`

**Description** `ts1 = gettsatevent(ts,event)` returns a new timeseries object `ts1` with samples occurring at an event in `ts`, where `event` can be either a `tsdata.event` object or a string. When `event` is a `tsdata.event` object, the time defined by `event` is used. When `event` is a string, the first `tsdata.event` object in the `Events` property of `ts` that matches the event name specifies the time.

`ts1 = gettsatevent(ts,event,n)` returns a new time series `ts1` with samples occurring at an event in time series `ts`, where `n` is the number of the event occurrence with a matching event name.

**Tips** When the timeseries object `ts` contains date strings and `event` uses numeric time, the time selected by the `event` is treated as a date that is calculated relative to the `StartDate` property in the `ts.TimeInfo`.

When `ts` uses numeric time and `event` uses calendar dates, the time selected by the `event` is treated as a numeric value that is not associated with a calendar date.

**See Also** `gettsafterevent` | `gettsafteratevent` | `gettsbeforeevent` | `gettsbetweenevents` | `timeseries`

**Purpose** New `timeseries` object with samples occurring before or at event

**Syntax**

```
ts1 = gettsbeforeatevent(ts,event)
ts1 = gettsbeforeatevent(ts,event,n)
```

**Description** `ts1 = gettsbeforeatevent(ts,event)` returns a new `timeseries` object `ts1` with samples occurring at and before an event in `ts`, where `event` can be either a `tsdata.event` object or a string. When `event` is a `tsdata.event` object, the time defined by `event` is used. When `event` is a string, the first `tsdata.event` object in the `Events` property of `ts` that matches the event name specifies the time.

`ts1 = gettsbeforeatevent(ts,event,n)` returns a new `timeseries` object `ts1` with samples occurring at and before an event in time series `ts`, where `n` is the number of the event occurrence with a matching event name.

**Tips** When the `timeseries` object `ts` contains date strings and `event` uses numeric time, the time selected by the event is treated as a date that is calculated relative to the `StartDate` property in `ts.TimeInfo`.

When `ts` uses numeric time and `event` uses calendar dates, the time selected by the event is treated as a numeric value that is not associated with a calendar date.

**See Also** `gettsafterevent` | `gettsbeforeevent` | `gettsbetweenevents` | `tsdata.event`

# gettsbeforeevent

---

**Purpose** New timeseries object with samples occurring before event

**Syntax**  
`ts1 = gettsbeforeevent(ts,event)`  
`ts1 = gettsbeforeevent(ts,event,n)`

**Description** `ts1 = gettsbeforeevent(ts,event)` returns a new `timeseries` object `ts1` with samples occurring before an event in `ts`, where `event` can be either a `tsdata.event` object or a string. When `event` is a `tsdata.event` object, the time defined by `event` is used. When `event` is a string, the first `tsdata.event` object in the `Events` property of `ts` that matches the event name specifies the time.

`ts1 = gettsbeforeevent(ts,event,n)` returns a new `timeseries` object `ts1` with samples occurring before an event in `ts`, where `n` is the number of the event occurrence with a matching event name.

**Tips** When the `timeseries` object `ts` contains date strings and `event` uses numeric time, the time selected by the `event` is treated as a date that is calculated relative to the `StartDate` property in `ts.TimeInfo`.

When `ts` uses numeric time and `event` uses calendar dates, the time selected by the `event` is treated as a numeric value that is not associated with a calendar date.

**See Also** `gettsafterevent` | `gettsbeforeatevent` | `gettsbetweenevents` | `tsdata.event`



**Purpose** New timeseries object with samples occurring between events

**Syntax**  
`ts1 = gettsbetweenevents(ts,event1,event2)`  
`ts1 = gettsbetweenevents(ts,event1,event2,n1,n2)`

**Description** `ts1 = gettsbetweenevents(ts,event1,event2)` returns a new timeseries object `ts1` with samples occurring between events in `ts`, where `event1` and `event2` can be either a `tsdata.event` object or a string. When `event1` and `event2` are `tsdata.event` objects, the time defined by the events is used. When `event1` and `event2` are strings, the first `tsdata.event` object in the `Events` property of `ts` that matches the event names specifies the time.

`ts1 = gettsbetweenevents(ts,event1,event2,n1,n2)` returns a new timeseries object `ts1` with samples occurring between events in `ts`, where `n1` and `n2` are the `n`th occurrences of the events with matching event names.

**Tips** When the timeseries object `ts` contains date strings and `event` uses numeric time, the time selected by the event is treated as a date that is calculated relative to the `StartDate` property in `ts.TimeInfo`.

When `ts` uses numeric time and `event` uses calendar dates, the time selected by the event is treated as a numeric value that is not associated with a calendar date.

**See Also** `gettsafterevent` | `gettsbeforeevent` | `tsdata.event`

# GetVariable

---

**Purpose** Data from variable in Automation server workspace

**Syntax** **IDL Method Signature**

```
HRESULT GetVariable([in] BSTR varname, [in] BSTR workspace, [out, retval] VARIANT* pdata)
```

**Microsoft Visual Basic Client**

```
GetVariable(varname As String, workspace As String) As Object
```

**MATLAB Client**

```
D = h.GetVariable('varname', 'workspace')
D = GetVariable(h, 'varname', 'workspace')
```

**Description** D = h.GetVariable('varname', 'workspace') gets data stored in variable varname from the specified workspace of the server attached to handle h and returns it in output argument D. The values for *workspace* are base or global.

D = GetVariable(h, 'varname', 'workspace') is an alternate syntax.

Do *not* use GetVariable on sparse arrays, structures, or function handles.

If your scripting language requires a result be returned explicitly, use the GetVariable function in place of GetWorkspaceData, GetFullMatrix or GetCharArray.

**Examples** This example uses a Visual Basic .NET client to read data from a MATLAB Automation server:

```
Dim Matlab As Object
Dim Result As String
Dim C2 As Variant
Matlab = CreateObject("matlab.application")
Result = Matlab.Execute("C1 = {25.72, 'hello', rand(4)};")
C2 = Matlab.GetVariable("C1", "base")
MsgBox("Second item in cell array: " & C2(0, 1))
```

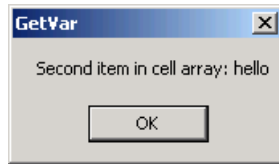

## See Also

[GetWorkspaceData](#) | [GetFullMatrix](#) | [GetCharArray](#) | [Execute](#)

## How To

- “Exchanging Data with the Server”

# Tiff.getVersion

---

**Purpose** LibTIFF library version

**Syntax** `versionString = Tiff.getVersion()`

**Description** `versionString = Tiff.getVersion()` returns the version number and other information about the LibTIFF library.

**Examples** Display version of LibTIFF library:

```
Tiff.getVersion
```

```
ans =
```

```
LIBTIFF, Version 3.9.5
Copyright (c) 1988-1996 Sam Leffler
Copyright (c) 1991-1996 Silicon Graphics, Inc.
```

**References** This method corresponds to the `TIFFGetVersion` function in the LibTIFF C API. To use this method, you must be familiar with the TIFF specification and technical notes. View this documentation at [LibTIFF - TIFF Library and Utilities](#).

**Purpose** Data from Automation server workspace

**Syntax** **IDL Method Signature**

```
HRESULT GetWorkspaceData([in] BSTR varname, [in] BSTR workspace, [out] VARIANT* pdata)
```

**Microsoft Visual Basic Client**

```
GetWorkspaceData(varname As String, workspace As String) As Object
```

**MATLAB Client**

```
D = h.GetWorkspaceData('varname', 'workspace')
D = GetWorkspaceData(h, 'varname', 'workspace')
```

**Description**

D = h.GetWorkspaceData('varname', 'workspace') gets data stored in variable varname from the specified workspace of the server attached to handle h and returns it in output argument D. The values for workspace are base or global.

D = GetWorkspaceData(h, 'varname', 'workspace') is an alternate syntax.

Use GetWorkspaceData instead of GetFullMatrix and GetCharArray to get numeric and character array data, respectively. Do *not* use GetWorkspaceData on sparse arrays, structures, or function handles.

For VBScript clients, use the GetWorkspaceData and PutWorkspaceData functions to pass numeric data to and from the MATLAB workspace. These functions use the variant data type instead of the safearray data type used by GetFullMatrix and PutFullMatrix. VBScript does not support safearray.

**Examples**

This example uses a Visual Basic .NET client to read data from a MATLAB Automation server:

```
Dim Matlab As Object
Dim C2 As Variant
Dim Result As String
```

# GetWorkspaceData

---

```
Matlab = CreateObject("matlab.application")
Result = MatLab.Execute("C1 = {25.72, 'hello', rand(4)};")
MsgBox("In MATLAB, type" & vbCrLf & "C1")
Matlab.GetWorkspaceData("C1", "base", C2)
MsgBox("second value of C1 = " & C2(0, 1))
```

## See Also

[PutWorkspaceData](#) | [GetFullMatrix](#) | [GetCharArray](#) | [GetVariable](#)  
| [Execute](#)

## How To

- “Exchanging Data with the Server”

---

|                    |                                                                                                                                                                                                                                                                                                                                                                                                                                                                                                                                                                                                                                                                                                                                                                                                                                                                                                                                                                                                                                                                                                                                                                                                                                                                              |
|--------------------|------------------------------------------------------------------------------------------------------------------------------------------------------------------------------------------------------------------------------------------------------------------------------------------------------------------------------------------------------------------------------------------------------------------------------------------------------------------------------------------------------------------------------------------------------------------------------------------------------------------------------------------------------------------------------------------------------------------------------------------------------------------------------------------------------------------------------------------------------------------------------------------------------------------------------------------------------------------------------------------------------------------------------------------------------------------------------------------------------------------------------------------------------------------------------------------------------------------------------------------------------------------------------|
| <b>Purpose</b>     | Graphical input from mouse or cursor                                                                                                                                                                                                                                                                                                                                                                                                                                                                                                                                                                                                                                                                                                                                                                                                                                                                                                                                                                                                                                                                                                                                                                                                                                         |
| <b>Syntax</b>      | <pre>[x,y] = ginput(n) [x,y] = ginput [x,y,button] = ginput(...)</pre>                                                                                                                                                                                                                                                                                                                                                                                                                                                                                                                                                                                                                                                                                                                                                                                                                                                                                                                                                                                                                                                                                                                                                                                                       |
| <b>Description</b> | <p>ginput raises crosshairs in the current axes to for you to identify points in the figure, positioning the cursor with the mouse. The figure must have focus before ginput can receive input. If it has no axes, one is created upon the first click or keypress.</p> <p>[x,y] = ginput(n) enables you to identify n points from the current axes and returns their x- and y-coordinates in the x and y column vectors. Press the <b>Return</b> key to terminate the input before entering n points.</p> <p>[x,y] = ginput gathers an unlimited number of points until you press the <b>Return</b> key.</p> <p>[x,y,button] = ginput(...) returns the x-coordinates, the y-coordinates, and the button or key designation. button is a vector of integers indicating which mouse buttons you pressed (1 for left, 2 for middle, 3 for right), or ASCII numbers indicating which keys on the keyboard you pressed.</p> <p>Clicking an axes makes that axes the current axes. Even if you set the current axes before calling ginput, whichever axes you click becomes the current axes and ginput returns points relative to that axes. If you select points from multiple axes, the results returned are relative to the coordinate system of the axes they come from.</p> |

---

**Note** MATLAB returns errors such as the following if you start MATLAB with the `noFigureWindows` or `nodisplay` flag and then run `ginput`:

```
Error using ginput (line 31)
Terminal mode is no longer supported
```

---

## Definitions

Coordinates returned by `ginput` are scaled to the `XLim` and `YLim` bounds of the axes you click (data units). Setting the axes or figure `Units` property has no effect on the output from `ginput`. You can click anywhere within the figure canvas to obtain coordinates. If you click outside the axes limits, `ginput` extrapolates coordinate values so they are still relative to the axes origin.

The figure `CurrentPoint` property, by contrast, is always returned in figure `Units`, irrespective of axes `Units` or limits.

## Examples

Pick 4 two-dimensional points from the figure window.

```
[x,y] = ginput(4)
```

Position the cursor with the mouse. Enter data points by pressing a mouse button or a key on the keyboard. To terminate input before entering 4 points, press the **Return** key.

```
x =
 0.2362
 0.5749
 0.5680
 0.2707
```

```
y =
 0.6711
 0.6769
 0.4313
```



```
0.4401
```

```
plot(x,y)
```

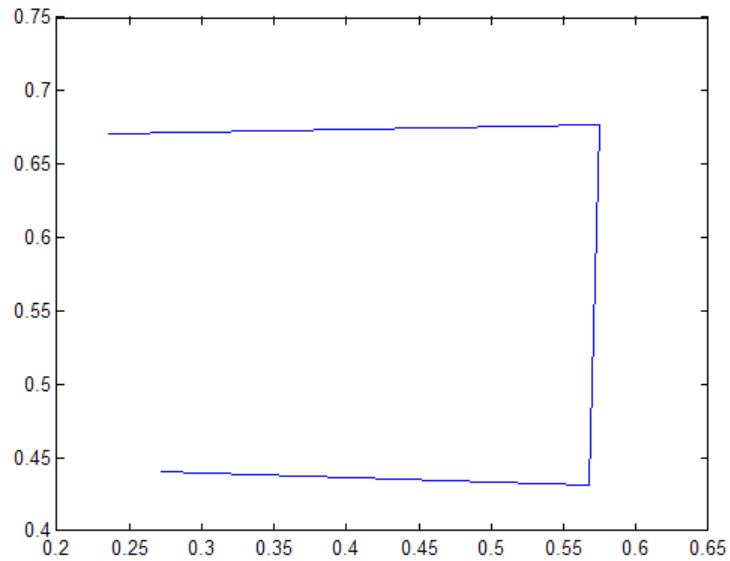

In this example, `plot` rescaled the axes *x*-limits and *y*-limits from `[0 1]` and `[0 1]` to `[0.20 0.65]` and `[0.40 0.75]`. The rescaling occurred because the axes `XLimMode` and `YLimMode` are set to `'auto'` (the default). Consider setting `XLimMode` and `YLimMode` to `'manual'` if you want to maintain consistency when you gather results from `ginput` and plot them together.

## See Also

`gtext`

## Tutorials

- “Subsetting a Graphics Image (Cropping)”

# global

---

**Purpose** Declare global variables

**Syntax** `global X Y Z`

**Description** `global X Y Z` defines X, Y, and Z as global in scope.

Ordinarily, each MATLAB function has its own local variables, which are separate from those of other functions, and from those of the base workspace. However, if several functions, and possibly the base workspace, all declare a particular name as global, they all share a single copy of that variable. Any assignment to that variable, in any function, is available to all the functions declaring it global.

If the global variable does not exist the first time you issue the `global` statement, it is initialized to the empty matrix.

If a variable with the same name as the global variable already exists in the current workspace, MATLAB issues a warning and changes the value of that variable to match the global.

**Tips** Use `clear global variable` to clear a global variable from the global workspace. Use `clear variable` to clear the global link from the current workspace without affecting the value of the global.

To use a global within a callback, declare the global, use it, then clear the global link from the workspace. This avoids declaring the global after it has been referenced. For example,

```
cbstr = sprintf('%s, %s, %s, %s, %s', ...
 'global MY_GLOBAL', ...
 'MY_GLOBAL = 100', ...
 'disp(MY_GLOBAL)', ...
 'MY_GLOBAL = MY_GLOBAL+1', ...
 'clear MY_GLOBAL');

uicontrol('style', 'pushbutton', 'CallBack', cbstr, ...
 'string', 'count')
```

There is no function form of the `global` command (i.e., you cannot use parentheses and quote the variable names).

## Examples

### Example 1

Type `edit global_demo1` at the command line and enter the following function definition in a new file named `global_demo1.m`.

```
function global_demo1(num)
global globalvar

if nargin > 0
 globalvar = num;
end

fprintf('Global variable in function %s is %d\n', ...
 mfilename, globalvar);
```

This function declares a global variable named `globalvar`. If you pass a value when calling the function, the function stores the value in `globalvar` and then displays it. If you call the function with no arguments, the function just displays the value last written to the global workspace.

Create another function `global_demo2` just like it. These two functions have separate function workspaces, but share a common global workspace:

```
copyfile global_demo1.m global_demo2.m
```

Call `global_demo1`, passing a numeric value. Then call `global_demo2` with no value. You can see that the latter function has global access to the value that was passed to `global_demo1`.

```
global_demo1(1357);
Global variable in function global_demo1 is 1357

global_demo2
Global variable in function global_demo2 is 1357
```

Now set the value in `global_demo2` and read it in `global_demo1`:

```
global_demo2(2468)
Global variable in function global_demo2 is 2468

global_demo1
Global variable in function global_demo1 is 2468
```

## Example 2

Call the function `global_demo1` that was defined in the previous example to assign a value to variable `globalvar` in the global workspace. Even though the variable is global, it is not accessible outside of the function workspace:

```
clear all
global_demo1(1357);
Global variable in function global_demo1 is 1357

if exist('globalvar', 'var')
 fprintf('Global variable is set to %d\n', globalvar);
else
 fprintf('Global variable is not available at the command line.\n');
end

Global variable is not available at the command line.
```

Now declare `globalvar` as a global variable at the MATLAB command line. Run the same statements to display the variable and this time you can see that the value assigned by the function is also available as a global variable in the base workspace:

```
global globalvar

if exist('globalvar', 'var')
 fprintf('Global variable is set to %d\n', globalvar);
else
```

```
 fprintf('Global variable is not available at the command line.\n');
end
```

```
Global variable is set to 1357
```

### Example 3

Here is the code for the functions `tic` and `toc` (some comments abridged). These functions manipulate a stopwatch-like timer. The global variable `TICTOC` is shared by the two functions, but it is invisible in the base workspace or in any other functions that do not declare it.

```
function tic
% TIC Start a stopwatch timer.
% TIC; any stuff; TOC
% prints the time required.
% See also: TOC, CLOCK.
global TICTOC
TICTOC = clock;

function t = toc
% TOC Read the stopwatch timer.
% TOC prints the elapsed time since TIC was used.
% t = TOC; saves elapsed time in t, does not print.
% See also: TIC, ETIME.
global TICTOC
if nargin < 1
 elapsed_time = etime(clock, TICTOC)
else
 t = etime(clock, TICTOC);
end
```

### See Also

`clear` | `isglobal` | `who`

**Purpose** Generalized minimum residual method (with restarts)

**Syntax**

```
x = gmres(A,b)
gmres(A,b,restart)
gmres(A,b,restart,tol)
gmres(A,b,restart,tol,maxit)
gmres(A,b,restart,tol,maxit,M)
gmres(A,b,restart,tol,maxit,M1,M2)
gmres(A,b,restart,tol,maxit,M1,M2,x0)
[x,flag] = gmres(A,b,...)
[x,flag,relres] = gmres(A,b,...)
[x,flag,relres,iter] = gmres(A,b,...)
[x,flag,relres,iter,resvec] = gmres(A,b,...)
```

**Description** `x = gmres(A,b)` attempts to solve the system of linear equations  $A*x = b$  for  $x$ . The  $n$ -by- $n$  coefficient matrix  $A$  must be square and should be large and sparse. The column vector  $b$  must have length  $n$ .  $A$  can be a function handle, `afun`, such that `afun(x)` returns  $A*x$ . For this syntax, `gmres` does not restart; the maximum number of iterations is  $\min(n,10)$ .

“Parameterizing Functions” explains how to provide additional parameters to the function `afun`, as well as the preconditioner function `mfun` described below, if necessary.

If `gmres` converges, a message to that effect is displayed. If `gmres` fails to converge after the maximum number of iterations or halts for any reason, a warning message is printed displaying the relative residual  $\text{norm}(b-A*x)/\text{norm}(b)$  and the iteration number at which the method stopped or failed.

`gmres(A,b,restart)` restarts the method every `restart` inner iterations. The maximum number of outer iterations is  $\min(n/\text{restart},10)$ . The maximum number of total iterations is  $\text{restart}*\min(n/\text{restart},10)$ . If `restart` is `n` or `[]`, then `gmres` does not restart and the maximum number of total iterations is  $\min(n,10)$ .

`gmres(A,b,restart,tol)` specifies the tolerance of the method. If `tol` is `[]`, then `gmres` uses the default,  $1e-6$ .

`gmres(A,b,restart,tol,maxit)` specifies the maximum number of outer iterations, i.e., the total number of iterations does not exceed `restart*maxit`. If `maxit` is `[]` then `gmres` uses the default, `min(n/restart,10)`. If `restart` is `n` or `[]`, then the maximum number of total iterations is `maxit` (instead of `restart*maxit`).

`gmres(A,b,restart,tol,maxit,M)` and `gmres(A,b,restart,tol,maxit,M1,M2)` use preconditioner `M` or `M = M1*M2` and effectively solve the system  $\text{inv}(M)*A*x = \text{inv}(M)*b$  for `x`. If `M` is `[]` then `gmres` applies no preconditioner. `M` can be a function handle `mfun` such that `mfun(x)` returns  $M \setminus x$ .

`gmres(A,b,restart,tol,maxit,M1,M2,x0)` specifies the first initial guess. If `x0` is `[]`, then `gmres` uses the default, an all-zero vector.

`[x,flag] = gmres(A,b,...)` also returns a convergence flag:

- `flag = 0`    `gmres` converged to the desired tolerance `tol` within `maxit` outer iterations.
- `flag = 1`    `gmres` iterated `maxit` times but did not converge.
- `flag = 2`    Preconditioner `M` was ill-conditioned.
- `flag = 3`    `gmres` stagnated. (Two consecutive iterates were the same.)

Whenever `flag` is not 0, the solution `x` returned is that with minimal norm residual computed over all the iterations. No messages are displayed if the `flag` output is specified.

`[x,flag,relres] = gmres(A,b,...)` also returns the relative residual  $\text{norm}(b-A*x)/\text{norm}(b)$ . If `flag` is 0, `relres`  $\leq$  `tol`. The third output, `relres`, is the relative residual of the preconditioned system.

`[x,flag,relres,iter] = gmres(A,b,...)` also returns both the outer and inner iteration numbers at which `x` was computed, where  $0 \leq \text{iter}(1) \leq \text{maxit}$  and  $0 \leq \text{iter}(2) \leq \text{restart}$ .

`[x,flag,relres,iter,resvec] = gmres(A,b,...)` also returns a vector of the residual norms at each inner iteration. These are the residual norms for the preconditioned system.

## Examples

### Using gmres with a Matrix Input

```
A = gallery('wilk',21);
b = sum(A,2);
tol = 1e-12;
maxit = 15;
M1 = diag([10:-1:1 1 1:10]);

x = gmres(A,b,10,tol,maxit,M1);
```

displays the following message:

```
gmres(10) converged at outer iteration 2 (inner iteration 9) to
a solution with relative residual 3.3e-013
```

### Using gmres with a Function Handle

This example replaces the matrix *A* in the previous example with a handle to a matrix-vector product function *afun*, and the preconditioner *M1* with a handle to a backsolve function *mfun*. The example is contained in a function *run\_gmres* that

- Calls *gmres* with the function handle *@afun* as its first argument.
- Contains *afun* and *mfun* as nested functions, so that all variables in *run\_gmres* are available to *afun* and *mfun*.

The following shows the code for *run\_gmres*:

```
function x1 = run_gmres
n = 21;
b = afun(ones(n,1));
tol = 1e-12; maxit = 15;
x1 = gmres(@afun,b,10,tol,maxit,@mfun);

function y = afun(x)
 y = [0; x(1:n-1)] + ...
 [((n-1)/2:-1:0)'; (1:(n-1)/2)'].*x + ...
 [x(2:n); 0];
end
```



```
function y = mfun(r)
 y = r ./ [((n-1)/2:-1:1)'; 1; (1:(n-1)/2)'];
end
end
```

When you enter

```
x1 = run_gmres;
```

MATLAB software displays the message

```
gmres(10) converged at outer iteration 2 (inner iteration 10)
to a solution with relative residual 1.1e-013.
```

### Using a Preconditioner without Restart

This example demonstrates the use of a preconditioner without restarting gmres.

Load west0479, a real 479-by-479 nonsymmetric sparse matrix.

```
load west0479;
A = west0479;
```

Set the tolerance and maximum number of iterations.

```
tol = 1e-12; maxit = 20;
```

Define **b** so that the true solution is a vector of all ones.

```
b = full(sum(A,2));
[x0,f10,rr0,it0,rv0] = gmres(A,b,[],tol,maxit);
```

f10 is 1 because gmres does not converge to the requested tolerance  $1e-12$  within the requested 20 iterations. The best approximate solution that gmres returns is the last one (as indicated by it0(2) = 20). MATLAB stores the residual history in rv0.

# gmres

Plot the behavior of gmres.

```
semilogy(0:maxit,rv0/norm(b),'-o');
xlabel('Iteration number');
ylabel('Relative residual');
```

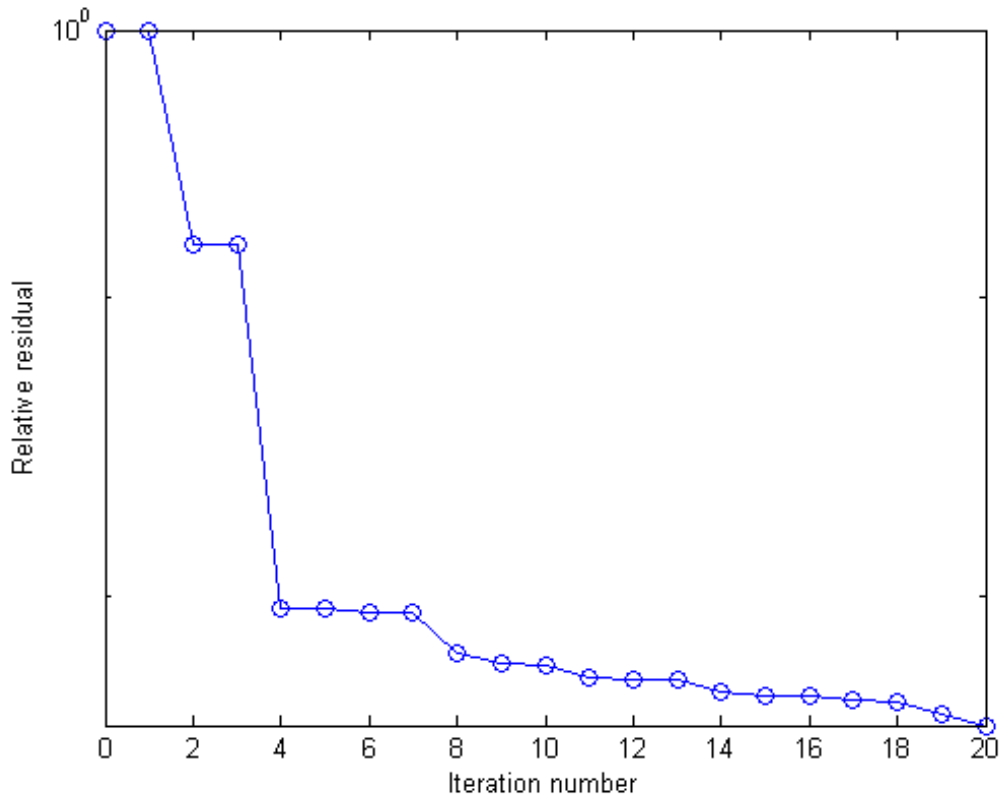

The plot shows that the solution converges slowly. A preconditioner may improve the outcome.

Use `ilu` to form the preconditioner, since  $A$  is nonsymmetric.

```
[L,U] = ilu(A,struct('type','ilutp','droptol',1e-5));
```

Error using ilu

There is a pivot equal to zero. Consider decreasing the drop tolerance or consider using the 'udiag' option.

Note MATLAB cannot construct the incomplete LU as it would result in a singular factor, which is useless as a preconditioner.

As indicated by the error message, try again with a reduced drop tolerance.

```
[L,U] = ilu(A,struct('type','ilutp','droptol',1e-6));
[x1,f11,rr1,it1,rv1] = gmres(A,b,[],tol,maxit,L,U);
```

f11 is 0 because gmres drives the relative residual to  $9.5436e-14$  (the value of rr1). The relative residual is less than the prescribed tolerance of  $1e-12$  at the sixth iteration (the value of it1(2)) when preconditioned by the incomplete LU factorization with a drop tolerance of  $1e-6$ . The output, rv1(1), is  $\text{norm}(M \setminus b)$ , where  $M = L * U$ . The output, rv1(7), is  $\text{norm}(U \setminus (L \setminus (b - A * x1)))$ .

Follow the progress of gmres by plotting the relative residuals at each iteration starting from the initial estimate (iterate number 0).

```
semilogy(0:it1(2),rv1/norm(b),'-o');
xlabel('Iteration number');
ylabel('Relative residual');
```

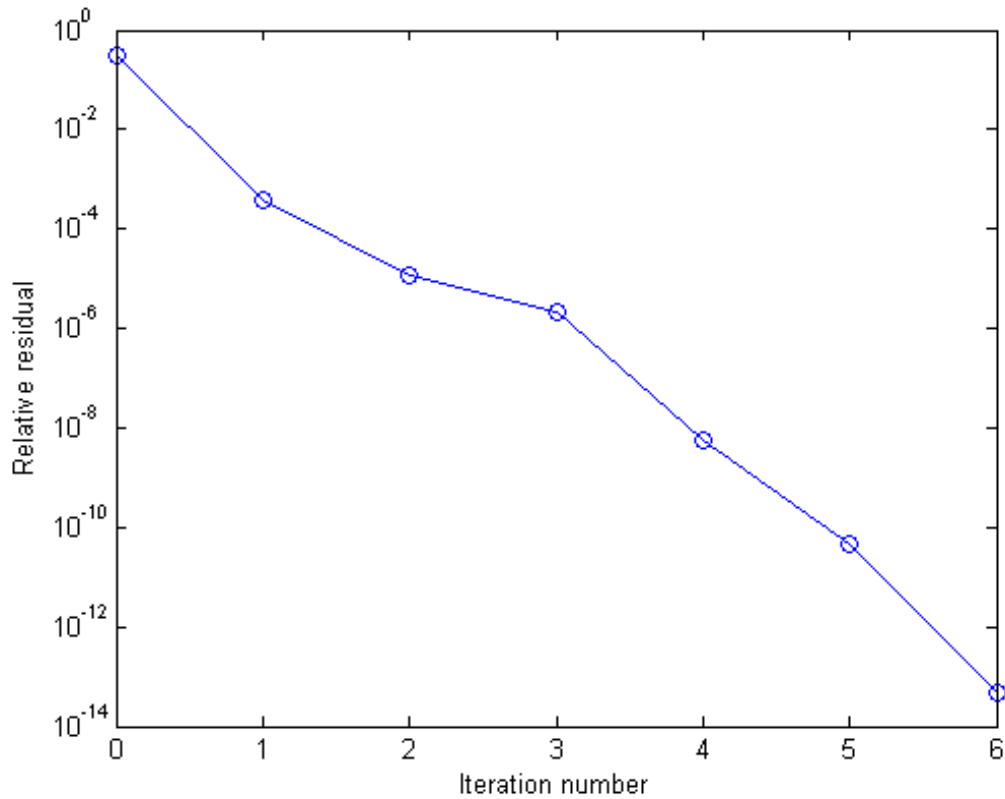

## Using a Preconditioner with Restart

This example demonstrates the use of a preconditioner with restarted gmres.

Load west0479, a real 479-by-479 nonsymmetric sparse matrix.

```
load west0479;
A = west0479;
```

Define `b` so that the true solution is a vector of all ones.

```
b = full(sum(A,2));
```

Construct an incomplete LU preconditioner as in the previous example.

```
[L,U] = ilu(A,struct('type','ilutp','droptol',1e-6));
```

The benefit to using restarted gmres is to limit the amount of memory required to execute the method. Without restart, gmres requires `maxit` vectors of storage to keep the basis of the Krylov subspace. Also, gmres must orthogonalize against all of the previous vectors at each step. Restarting limits the amount of workspace used and the amount of work done per outer iteration. Note that even though preconditioned gmres converged in six iterations above, the algorithm allowed for as many as twenty basis vectors and therefore, allocated all of that space up front.

Execute `gmres(3)`, `gmres(4)`, and `gmres(5)`

```
tol = 1e-12; maxit = 20;
re3 = 3;
[x3,f13,rr3,it3,rv3] = gmres(A,b,re3,tol,maxit,L,U);
re4 = 4;
[x4,f14,rr4,it4,rv4] = gmres(A,b,re4,tol,maxit,L,U);
re5 = 5;
[x5,f15,rr5,it5,rv5] = gmres(A,b,re5,tol,maxit,L,U);
```

`f13`, `f14`, and `f15` are all 0 because in each case restarted gmres drives the relative residual to less than the prescribed tolerance of  $1e-12$ .

The following plots show the convergence histories of each restarted gmres method. `gmres(3)` converges at outer iteration 5, inner iteration 3 (`it3 = [5, 3]`) which would be the same as outer iteration 6, inner iteration 0, hence the marking of 6 on the final tick mark.

```
figure
semilogy(1:1/3:6,rv3/norm(b),'-o');
set(gca,'XTick',[1:1/3:6],...
 'XTickLabel',...)
```

```
 ['1';' ',' ','2';' ',' ','3';' ',' ','4';' ',' ','5';' ',' ','6'];])
title('gmres(3)')
xlabel('Iteration number');
ylabel('Relative residual');

figure
semilogy(1:1/4:3,rv4/norm(b),'-o');
set(gca,'XTick',[1:1/4:3],...
 'XTickLabel',['1';' ',' ','2';' ',' ','3'])
title('gmres(4)')
xlabel('Iteration number');
ylabel('Relative residual');

figure
semilogy(1:1/5:2.8,rv5/norm(b),'-o');
set(gca,'XTick',[1:1/5:2.8],...
 'XTickLabel',['1';' ',' ','2';' ',' ',' '])
title('gmres(5)')
xlabel('Iteration number');
ylabel('Relative residual');
```

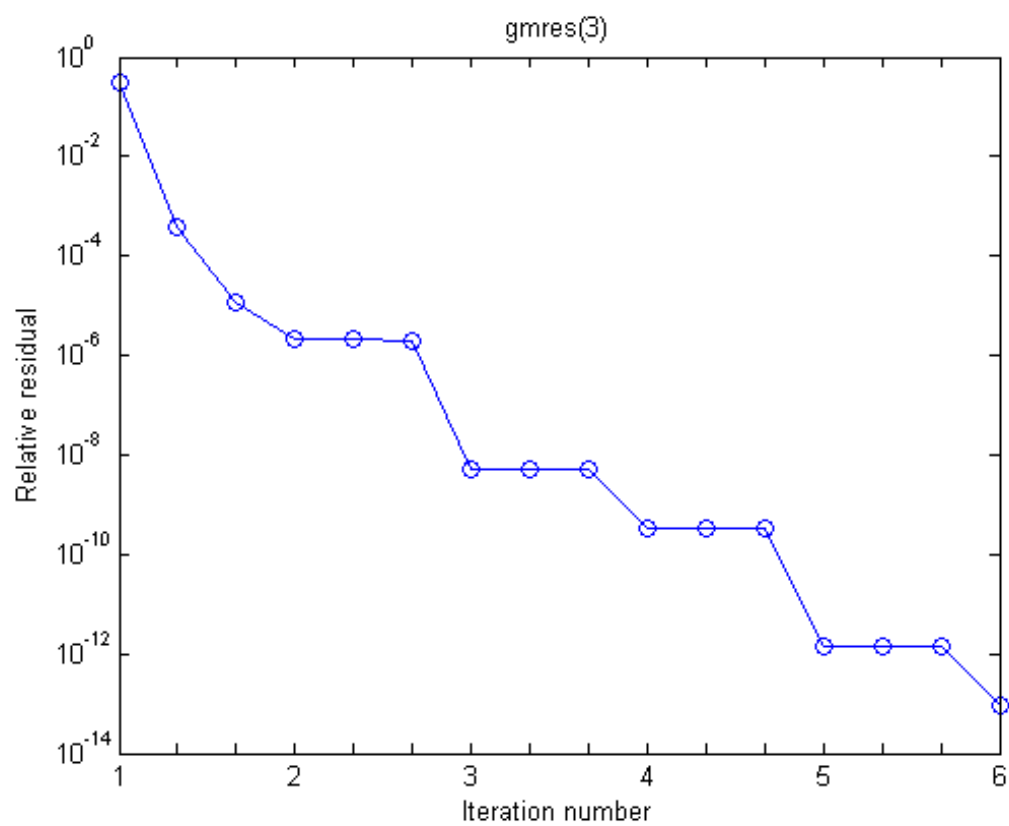

# gmres

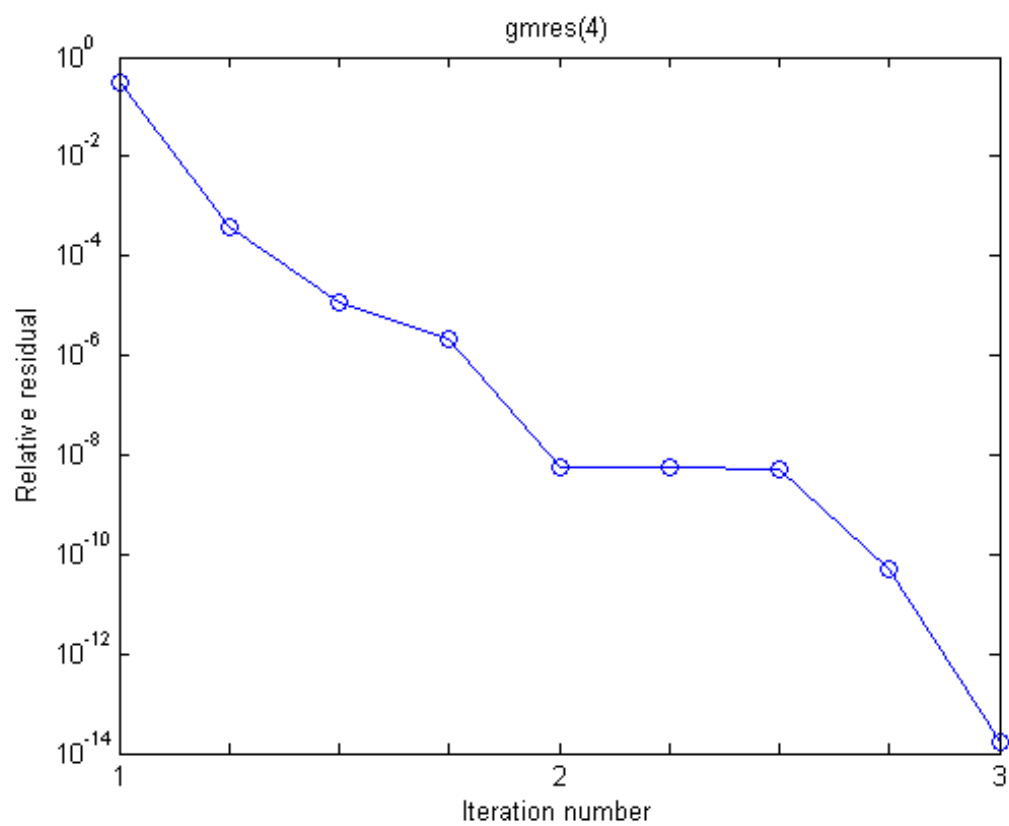



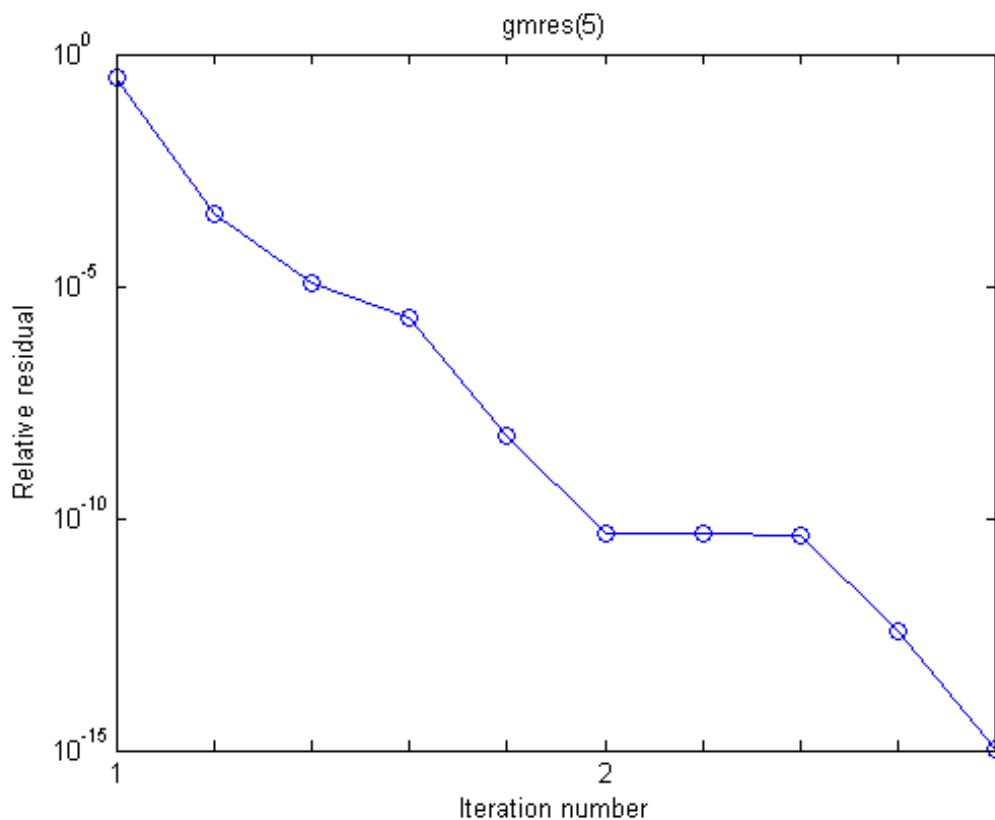

## References

Barrett, R., M. Berry, T. F. Chan, et al., *Templates for the Solution of Linear Systems: Building Blocks for Iterative Methods*, SIAM, Philadelphia, 1994.

Saad, Youcef and Martin H. Schultz, "GMRES: A generalized minimal residual algorithm for solving nonsymmetric linear systems," *SIAM J. Sci. Stat. Comput.*, July 1986, Vol. 7, No. 3, pp. 856-869.

# gmres

---

## **See Also**

`bicg` | `bicgstab` | `cgs` | `function_handle` | `ilu` | `lsqr` | `minres` |  
`pcg` | `qmr` | `symmlq` | `mldivide`

**Purpose** Create array of graphics handles

**Syntax**

```
H = gobjects(n)
H = gobjects(s1,...,sn)
H = gobjects(v)
```

```
H = gobjects
H = gobjects(0)
```

**Description** H = gobjects(n) returns an n-by-n array of graphics handles. Use the gobjects function instead of the ones or zeros functions to preallocate an array to store graphics handles.

H = gobjects(s1,...,sn) returns an s1-by-...-by-sn array of graphics handles, where the list of integers s1,...,sn defines the dimensions of the array. For example, gobjects(2,3) returns a 2-by-3 array.

H = gobjects(v) returns an array of graphics handles where the elements of the row vector, v, define the dimensions of the array. For example, gobjects([2,3,4]) returns a 2-by-3-by-4 array.

H = gobjects returns a 1-by-1 graphics handle array.

H = gobjects(0) returns empty.

## Input Arguments

### **n - Size of square matrix**

integer value

Size of the square matrix, specified as an integer value. Negative integers are treated as 0. The square matrix has dimensions n-by-n.

### **Data Types**

single | double | int8 | int16 | int32 | int64 | uint8 |  
uint16 | uint32 | uint64

## **s1,...,sn - Size of each array dimension**

two or more integer values

Size of each array dimension, specified as a list of two or more integer values. Negative integers are treated as 0.

### **Data Types**

single | double | int8 | int16 | int32 | int64 | uint8 |  
uint16 | uint32 | uint64

## **v - Size of each array dimension**

row vector of integer values

Size of each array dimension, specified as a row vector of integer values. Negative integers are treated as 0.

**Example:** [2,4,6,7]

### **Data Types**

single | double | int8 | int16 | int32 | int64 | uint8 |  
uint16 | uint32 | uint64

## **Examples**

### **Specify Array Dimensions**

Preallocate a 4-by-1 array to store graphics handles.

```
H = gobjects(4,1)
```

```
H =
```

```
0
0
0
0
```

## Specify Array Dimensions with Size of Existing Array

Create an array to store graphics handles using the size of an existing array.

Define A as a 3-by-4 array.

```
A = [1,2,3,2; 4,5,6,6; 7,8,9,7];
```

Create an array of graphics handles using the size of A.

```
v = size(A);
H = gobjects(v);
```

The dimensions of the graphics handle array are the same as the dimensions of A.

```
isequal(size(H),size(A))
```

```
ans =
```

```
1
```

## Return Empty Handle Array

Use the `gobjects` function to return an empty array.

```
H = gobjects(0)
```

```
H =
```

```
[]
```

# gplot

---

**Purpose** Plot nodes and links representing adjacency matrix

**Syntax** `gplot(A,Coordinates)`  
`gplot(A,Coordinates,LineSpec)`

**Description** The `gplot` function graphs a set of coordinates using an adjacency matrix.

`gplot(A,Coordinates)` plots a graph of the nodes defined in `Coordinates` according to the  $n$ -by- $n$  adjacency matrix `A`, where  $n$  is the number of nodes. `Coordinates` is an  $n$ -by-2 matrix, where  $n$  is the number of nodes and each coordinate pair represents one node.

`gplot(A,Coordinates,LineSpec)` plots the nodes using the line type, marker symbol, and color specified by `LineSpec`.

**Tips** For two-dimensional data, `Coordinates(i,:) = [x(i) y(i)]` denotes node  $i$ , and `Coordinates(j,:) = [x(j) y(j)]` denotes node  $j$ . If node  $i$  and node  $j$  are connected, `A(i,j)` or `A(j,i)` is nonzero; otherwise, `A(i,j)` and `A(j,i)` are zero.

## **Examples** Plot Graph of Nodes Using Asterisks

Plot half of a "Bucky ball" carbon molecule, placing asterisks at each node.

```
k = 1:30;
[B,XY] = bucky;
gplot(B(k,k),XY(k,:), '-*')
axis square
```

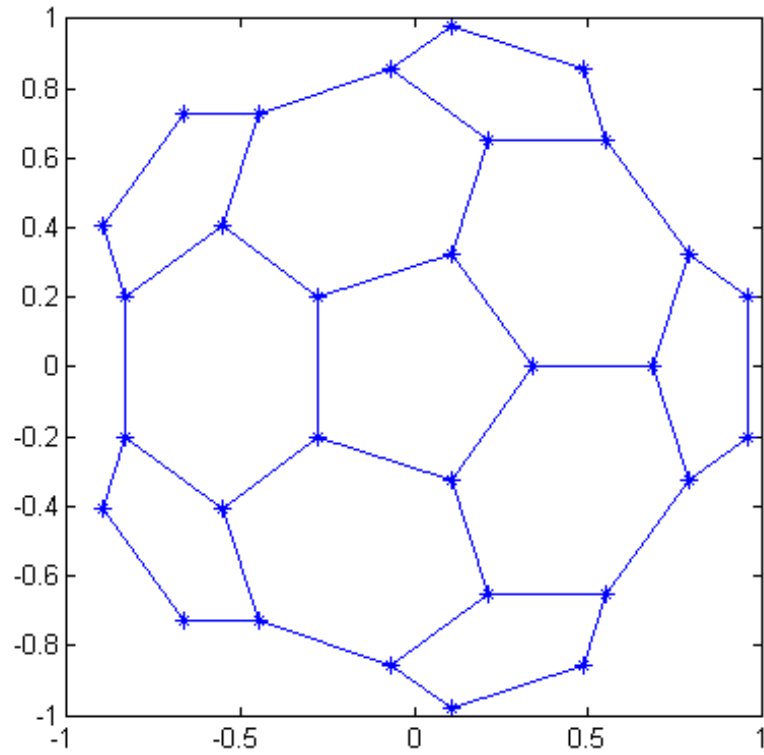

**See Also** [LineSpec](#) | [sparse](#) | [spy](#)

# grabcode

---

**Purpose** Extract MATLAB code from file published to HTML

**Syntax**

```
grabcode('name.html')
grabcode('urlname')
codeString = grabcode('name.html')
```

**Description** `grabcode('name.html')` copies MATLAB code from the file `name.html` and pastes it into an untitled document in the Editor. Use `grabcode` to get MATLAB code from published files when the source code is not readily available. The file `name.html` was created by publishing `name.m`, a MATLAB code file containing cells. The MATLAB code from `name.m` is included at the end of `name.html` as HTML comments.

`grabcode('urlname')` copies MATLAB code from the `urlname` location and pastes it into an untitled document in the Editor.

`codeString = grabcode('name.html')` gets MATLAB code from the file `name.html` and assigns it the variable `codeString`.

**Examples** This example illustrates how to use `grabcode` to get MATLAB code from an existing HTML file:

```
% Copy sine_wave_f.html and the images it includes
% from the MATLAB examples directory to your
% current folder:

copyfile(fullfile(matlabroot,'help','techdoc','matlab_env',...
 'examples','sine_wave_f.html'),'my_sine_wave.html')

copyfile(fullfile(matlabroot,'help','techdoc','matlab_env',...
 'examples','sine_wave_f_01.png'),'sine_wave_f_01.png')

copyfile(fullfile(matlabroot,'help','techdoc','matlab_env',...
 'examples','sine_wave_f_02.png'),'sine_wave_f_02.png')

% If you want to view the file, double-click my_sine_wave.html
% in your current folder.
```



```
% Extract the MATLAB code from sine_wave_f.html:
code = grabcode('my_sine_wave.html')
```

MATLAB returns:

```
code =
```

```
%% Plot Sine Wave
% Calculate and plot a sine wave.

%% Calculate and Plot Sine Wave
% Calculate and plot |y = sin(x)|.
```

```
function sine_wave_f(x)
```

```
y = sin(x);
plot(x,y)
```

```
%% Modify Plot Properties
```

```
title('Sine Wave', 'FontWeight','bold')
xlabel('x')
ylabel('sin(x)')
set(gca, 'Color', 'w')
set(gcf, 'MenuBar', 'none')
```

## See Also

```
publish
```

# gradient

---

**Purpose** Numerical gradient

**Syntax**  
FX = gradient(F)  
[FX,FY] = gradient(F)  
[FX,FY,FZ,...] = gradient(F)  
[...] = gradient(F,h)  
[...] = gradient(F,h1,h2,...)

**Definitions** The *gradient* of a function of two variables,  $F(x,y)$ , is defined as

$$\nabla F = \frac{\partial F}{\partial x} \hat{i} + \frac{\partial F}{\partial y} \hat{j}$$

and can be thought of as a collection of vectors pointing in the direction of increasing values of  $F$ . In MATLAB software, numerical gradients (differences) can be computed for functions with any number of variables. For a function of  $N$  variables,  $F(x,y,z, \dots)$ ,

$$\nabla F = \frac{\partial F}{\partial x} \hat{i} + \frac{\partial F}{\partial y} \hat{j} + \frac{\partial F}{\partial z} \hat{k} + \dots$$

**Description** FX = gradient(F), where F is a vector, returns the one-dimensional numerical gradient of F. Here FX corresponds to  $\partial F/\partial x$ , the differences in x (horizontal) direction.

[FX,FY] = gradient(F), where F is a matrix, returns the  $x$  and  $y$  components of the two-dimensional numerical gradient. FX corresponds to  $\partial F/\partial x$ , the differences in  $x$  (horizontal) direction. FY corresponds to  $\partial F/\partial y$ , the differences in the  $y$  (vertical) direction. The spacing between points in each direction is assumed to be one.

[FX,FY,FZ,...] = gradient(F), where F has  $N$  dimensions, returns the  $N$  components of the gradient of F. There are two ways to control the spacing between values in F:

- A single spacing value, h, specifies the spacing between points in every direction.

- N spacing values (h1, h2, ...) specifies the spacing for each dimension of F. Scalar spacing parameters specify a constant spacing for each dimension. Vector parameters specify the coordinates of the values along corresponding dimensions of F. In this case, the length of the vector must match the size of the corresponding dimension.

---

**Note** The first output FX is always the gradient along the 2nd dimension of F, going across columns. The second output FY is always the gradient along the 1st dimension of F, going across rows. For the third output FZ and the outputs that follow, the Nth output is the gradient along the Nth dimension of F.

---

[...] = gradient(F,h), where h is a scalar, uses h as the spacing between points in each direction.

[...] = gradient(F,h1,h2,...) with N spacing parameters specifies the spacing for each dimension of F.

## Examples

### Contour Plot of Vector Field

Calculate the 2-D gradient of  $xe^{-x^2-y^2}$  on a grid.

```
v = -2:0.2:2;
[x,y] = meshgrid(v);
z = x .* exp(-x.^2 - y.^2);
[px,py] = gradient(z,.2,.2);
```

Plot the contour lines and vectors in the same figure.

```
contour(v,v,z)
hold on
quiver(v,v,px,py)
hold off
```

# gradient

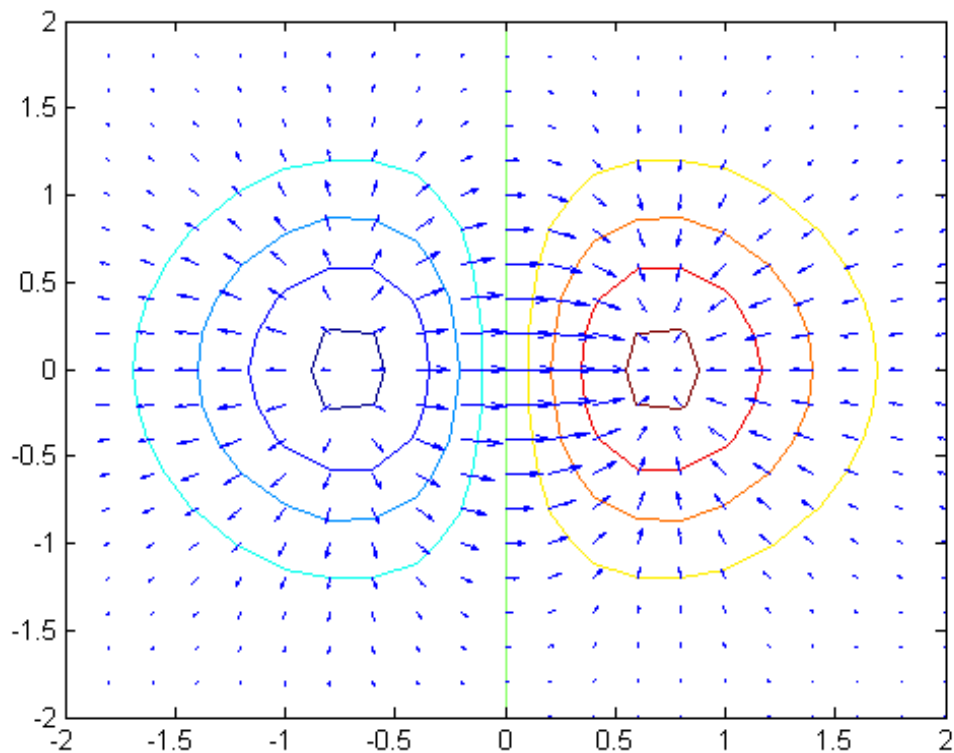

## Specify Dimensional Spacing of Points

Create a 3-D array.

```
F(:,:,1) = magic(3);
F(:,:,2) = pascal(3);
```

The command,

```
gradient(F)
```

takes  $dx = dy = dz = 1$ . However, the command,

```
[PX,PY,PZ] = gradient(F,0.2,0.1,0.2)
```

takes  $dx = 0.2$ ,  $dy = 0.1$ , and  $dz = 0.2$ .

## Algorithms

`gradient` calculates the central difference between data points. For an array, matrix, or vector with  $N$  values in each row, the  $i$ th value is defined by

$$A_i = \frac{1}{2} \sum_{i=2}^{N-1} A_{i+1} - A_{i-1}.$$

The gradient at the end points, where  $i=1$  and  $i=N$ , is calculated with a single-sided difference between the endpoint value and the next adjacent value within the row. If two or more outputs are specified, `gradient` also calculates central differences along other dimensions. Unlike the `diff` function, `gradient` returns an array with the same number of elements as the input.

## See Also

`del2` | `diff`

# graymon

---

|                    |                                                                                                                     |
|--------------------|---------------------------------------------------------------------------------------------------------------------|
| <b>Purpose</b>     | Set default figure properties for grayscale monitors                                                                |
| <b>Syntax</b>      | <code>graymon</code>                                                                                                |
| <b>Description</b> | <code>graymon</code> sets defaults for graphics properties to produce more legible displays for grayscale monitors. |
| <b>See Also</b>    | <code>axes</code>   <code>figure</code>                                                                             |

**Purpose** Grid lines for 2-D and 3-D plots

**Syntax** `grid on`  
`grid off`  
`grid`  
`grid minor`  
`grid(axes_handle,...)`

**Description** `grid on` adds major grid lines to the current axes.  
`grid off` removes all grid lines from the current axes.  
`grid` toggles the visibility of the major grid lines of the current axes.  
`grid minor` toggles the visibility of the minor grid lines of the current axes.  
`grid(axes_handle,...)` uses the axes specified by `axes_handle` instead of the current axes.

**Examples** **Display Grid Lines**

Display the grid lines for a sine plot.

```
x = linspace(0,10);
y = sin(x);

figure
plot(x,y);
grid on;
```

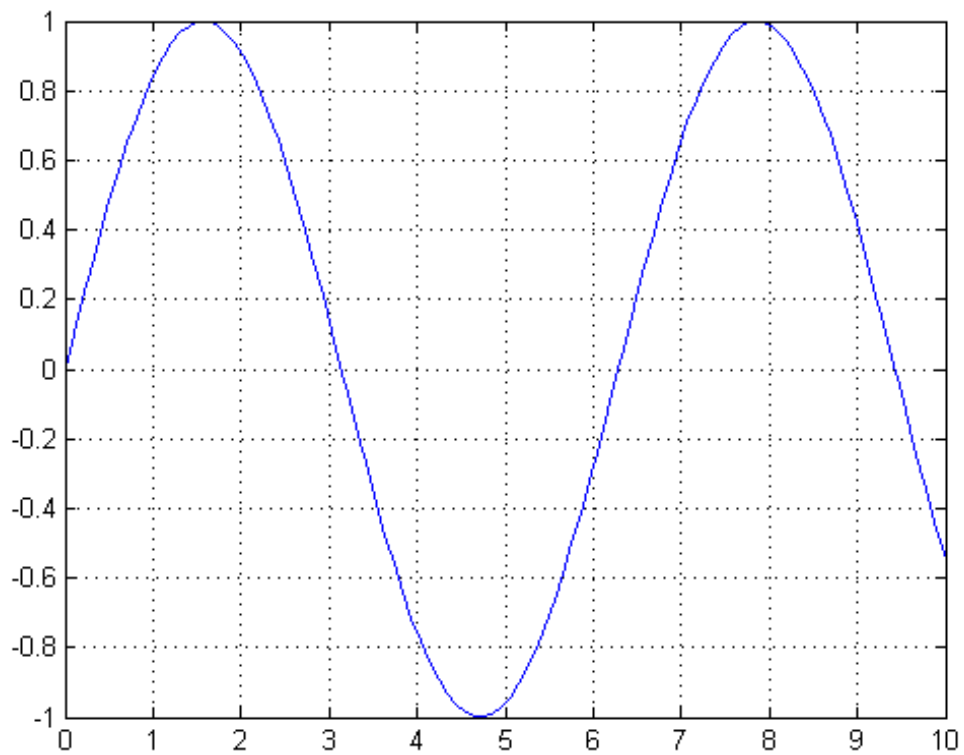

## Remove Grid Lines

Create a surface plot of the peaks function.

```
figure
surf(peaks);
```



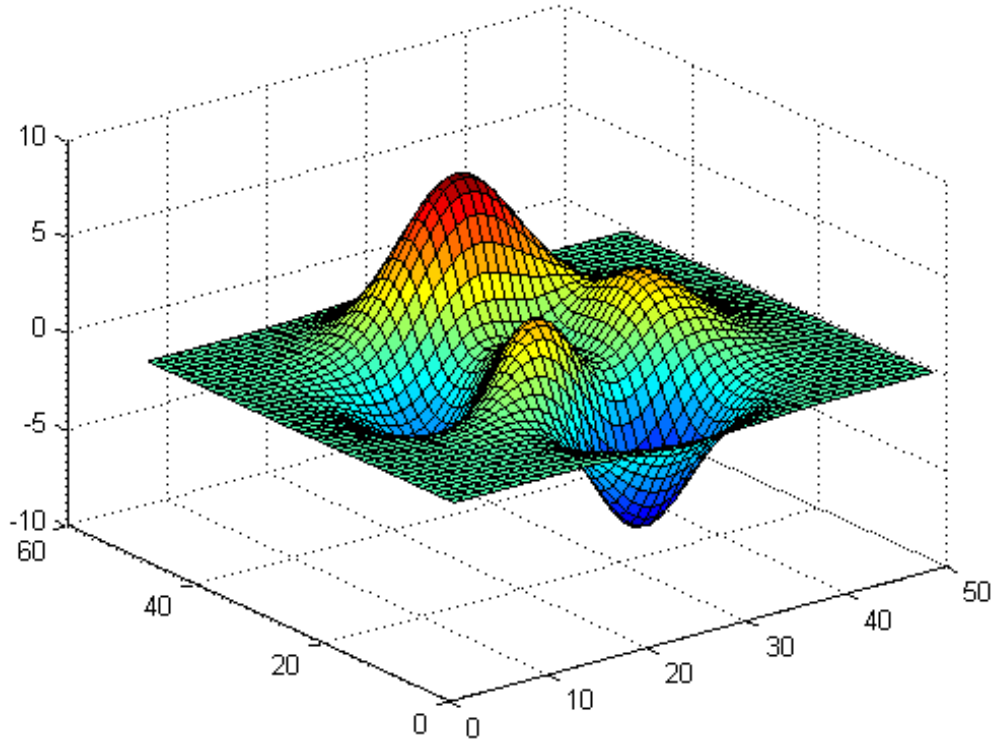

Remove the grid lines from the surface plot.

```
grid off
```

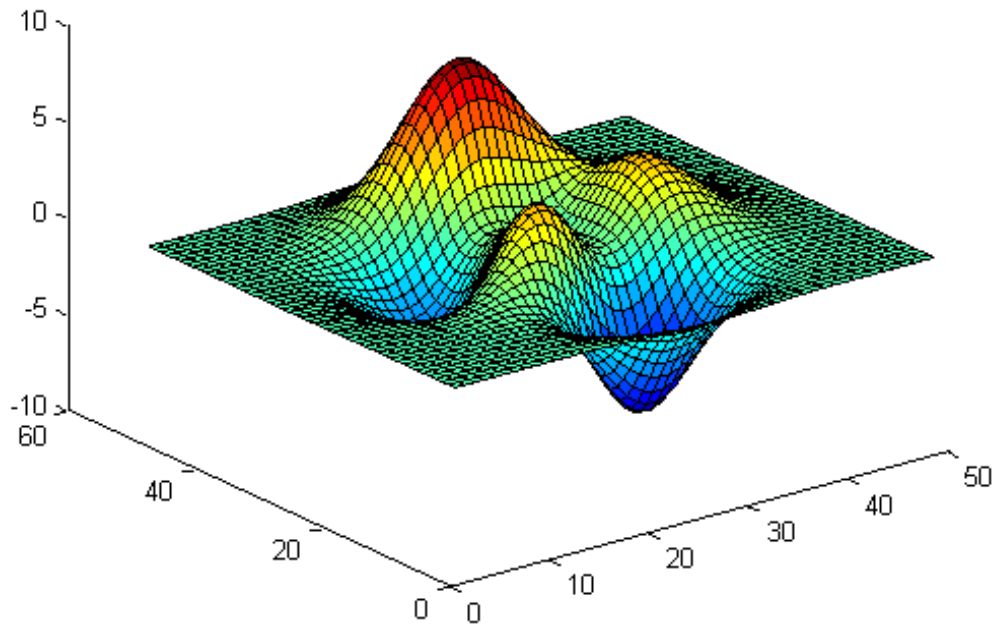

## Display Major and Minor Grid Lines

Define a vector of random numbers.

```
rng(0,'twister');
randnumbers = rand(1,20);
```

Plot the vector. Display the major and minor grid lines on the graph.

```
figure
```

```
plot(randnumbers)
grid on
grid minor
```

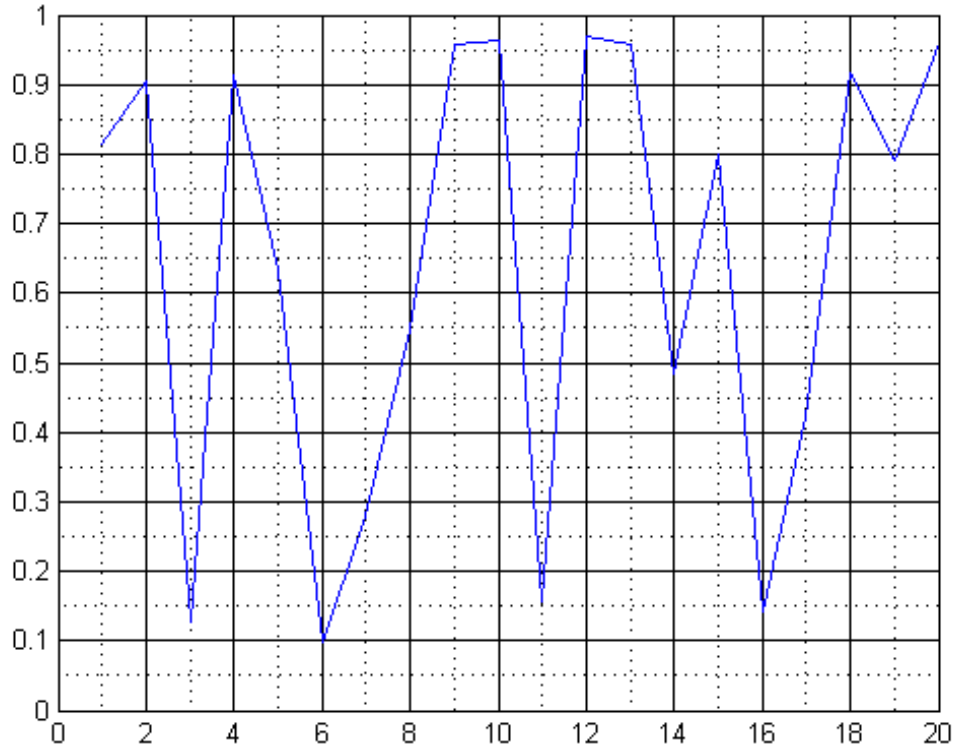

## Algorithms

Some axes properties control the axes grid lines. For more information on axes properties see [Axes Properties](#).

`grid` sets the `XGrid`, `YGrid`, and `ZGrid` properties of the axes.

To control the major grid line visibility separately for each axis direction set the `XGrid`, `YGrid`, and `ZGrid` axes properties. These properties can be set to on or off.

```
axh = gca;
set(axh, 'XGrid', 'on')
set(axh, 'ZGrid', 'off')
```

`grid minor` sets the `XMinorGrid`, `YMinorGrid`, and `ZMinorGrid` properties of the axes.

To control the minor grid line visibility separately for each axis direction set the `XMinorGrid`, `YMinorGrid`, and `ZMinorGrid` axes properties. These properties can be set to on or off.

```
axh = gca;
set(axh, 'XMinorGrid', 'on')
```

To change the grid line width, set the `LineWidth` axes property.

```
axh = gca;
set(axh, 'LineWidth', 2);
```

By default, the number of grid lines changes when you resize a figure. To keep the same number of grid lines for any figure size, set the `XTickMode`, `YTickMode`, or `ZTickMode` axes properties to `'manual'`.

```
axh = gca;
set(axh, 'XTickMode', 'manual');
```

To customize the locations of the tick marks along an axis, set the `XTick`, `YTick`, and `ZTick` axes properties.

```
axh = gca;
set(axh, 'XTick', [0:5:50]);
```

To turn on and off the display of the minor tick marks along an axis, set the `XMinorTick`, `YMinorTick`, and `ZMinorTick` properties to on or off.

```
axh = gca;
set(axh, 'XMinorTick', 'on')
```

## See Also

[box](#) | [gca](#) | [axes](#) | [set](#)

# griddata

---

## Purpose

Interpolate scattered data

---

**Note** Qhull-specific options are no longer supported. Remove the `OPTIONS` argument from all instances in your code that pass it to `griddata`.

In a future release, the following syntaxes will be removed:

```
[Xq,Yq,Vq] = griddata(x,y,v,xq,yq)
[Xq,Yq,Vq] = griddata(x,y,v,xq,yq, method)
```

In addition, `griddata` will not accept any input vectors of mixed orientation in a future release. To specify a grid of query points, construct a full grid with `ndgrid` or `meshgrid` before calling `griddata`.

---

## Syntax

```
vq = griddata(x,y,v,xq,yq)
vq = griddata(x,y,z,v,xq,yq,zq)
vq = griddata(..., method)
```

## Description

`vq = griddata(x,y,v,xq,yq)` fits a surface of the form  $v = f(x,y)$  to the scattered data in the vectors  $(x,y,v)$ . The `griddata` function interpolates the surface at the query points specified by  $(xq,yq)$  and returns the interpolated values, `vq`. The surface always passes through the data points defined by  $x$  and  $y$ .

`vq = griddata(x,y,z,v,xq,yq,zq)` fits a hypersurface of the form  $v = f(x,y,z)$ .

`vq = griddata(..., method)` uses a specified interpolation method to compute `vq`.

## Input Arguments

**x**

Vector specifying the  $x$ - coordinates of the sample points.

**y**

Vector specifying the  $y$ - coordinates of the sample points.

**z**

Vector specifying the  $z$ - coordinates of the sample points.

**v**

Vector of sample values that correspond to the sample coordinates  $x$ ,  $y$  (and  $z$  for 3-D interpolation).

**xq**

Vector or array that specifies  $x$ - coordinates of the query points to be evaluated.  $xq$  must be the same size as  $yq$  (and  $zq$  for 3-D interpolation).

- Specify an array if you want to pass a grid of query points. Use `ndgrid` or `meshgrid` to construct the array.
- Specify a vector if you want to pass a collection of scattered points.

**yq**

Vector or array that specifies  $y$ - coordinates of the query points to be evaluated.  $yq$  must be the same size as  $xq$  (and  $zq$  for 3-D interpolation).

- Specify an array if you want to pass a grid of query points. Use `ndgrid` or `meshgrid` to construct the array.
- Specify a vector if you want to pass a collection of scattered points.

**zq**

Vector or array that specifies  $z$ - coordinates of the query points to be evaluated.  $zq$  must be the same size as  $xq$  and  $yq$ .

- Specify an array if you want to pass a grid of query points. Use `ndgrid` or `meshgrid` to construct the array.
- Specify a vector if you want to pass a collection of scattered points.

**method**

Keyword that specifies the interpolation method. Use one of the following:

|           |                                |
|-----------|--------------------------------|
| 'linear'  | Linear interpolation (default) |
| 'cubic'   | Cubic interpolation            |
| 'natural' | Natural neighbor interpolation |
| 'nearest' | Nearest neighbor interpolation |
| 'v4'      | MATLAB 4 griddata method       |

## Output Arguments

### **vq**

The interpolated values at the query points.

- For 2-D interpolation, where `xq` and `yq` specify an `m`-by-`n` grid of query points, `vq` is an `m`-by-`n` array.
- For 3-D interpolation, where `xq`, `yq`, and `zq` specify an `m`-by-`n`-by-`p` grid of query points, `vq` is an `m`-by-`n`-by-`p` array.
- If `xq`, `yq`, (and `zq` for 3-D interpolation) are vectors that specify scattered points, `vq` is a vector of the same length.

## Examples

### **Interpolate Scattered Data Over a Uniform Grid**

Sample a function at 200 random points between -2.5 and 2.5.

```
xy = -2.5 + 5*gallery('uniformdata',[200 2],0);
x = xy(:,1); y = xy(:,2);
v = x.*exp(-x.^2-y.^2);
```

`x`, `y`, and `v` are vectors containing scattered (nonuniform) sample points and data.

Define a regular grid and interpolate the scattered data over the grid.

```
[xq,yq] = meshgrid(-2:.2:2, -2:.2:2);
vq = griddata(x,y,v,xq,yq);
```



Plot the gridded data as a mesh and the scattered data as dots.

```
figure
mesh(xq,yq,vq);
hold on
plot3(x,y,v,'o');
h = gca;
set(h,'XLim',[-2.7 2.7]);
set(h,'YLim',[-2.7 2.7]);
```

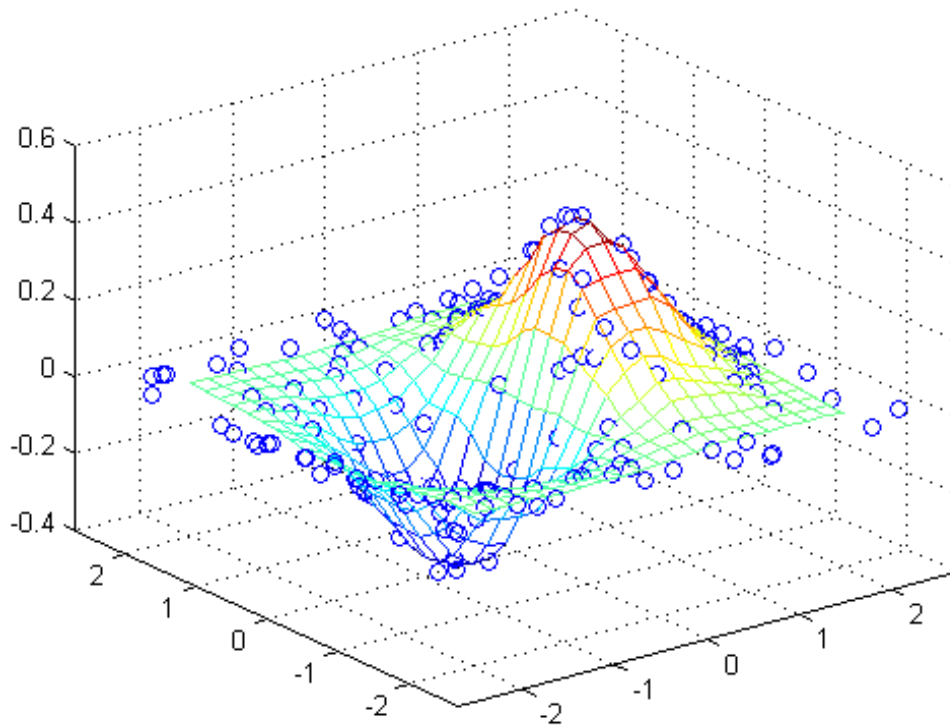

## Interpolate 3-D Data Set Over a Grid in the x-y Plane

Sample a function at 5000 random points between -1 and 1.

```
rng(0,'twister')
x = 2*rand(5000,1)-1;
y = 2*rand(5000,1)-1;
z = 2*rand(5000,1)-1;
v = x.^2 + y.^2 + z.^2;
```

$x$ ,  $y$ , and  $z$  are now vectors containing nonuniformly sampled data.

Define a regular grid with points in the range  $[-0.8, 0.8]$ .

```
d = -0.8:0.05:0.8;
[xq,yq,zq] = meshgrid(d,d,0);
```

Interpolate the scattered data over a rectangular region at  $z=0$ . Then, plot the results.

```
vq = griddata(x,y,z,v,xq,yq,zq);
surf(xq,yq,vq);
set(gca,'XTick',[-1 -0.5 0 0.5 1]);
set(gca,'YTick',[-1 -0.5 0 0.5 1]);
```

# griddata

---

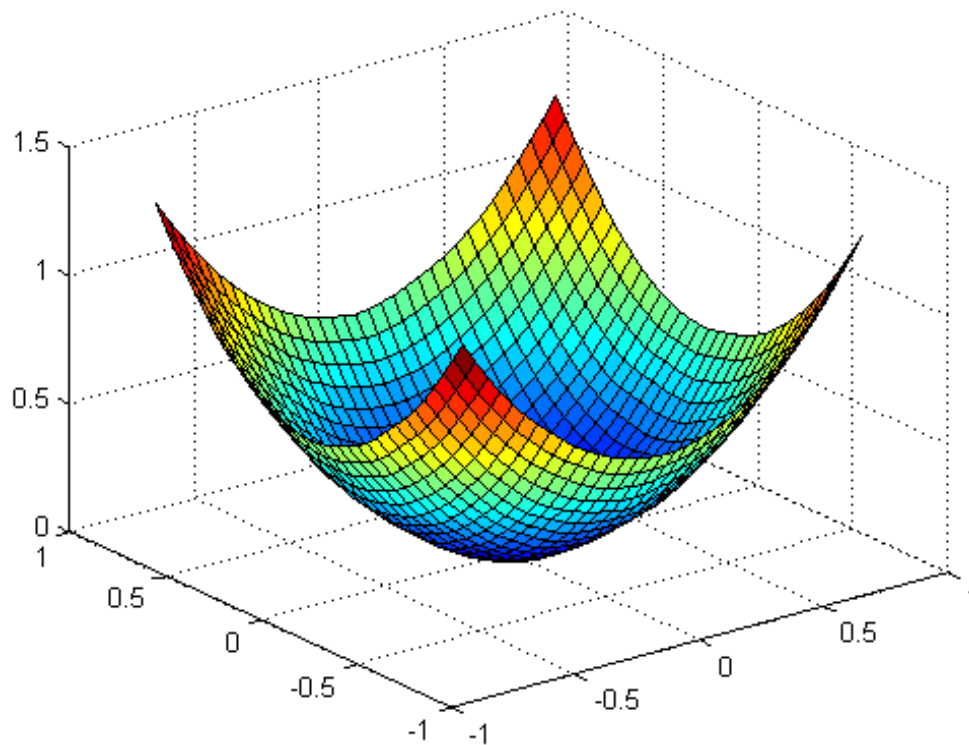

## See Also

[scatteredInterpolant](#) | [delaunay](#) | [griddatan](#) | [interp](#) | [meshgrid](#)  
| [ndgrid](#)

**Purpose** Data gridding and hypersurface fitting (dimension  $\geq 2$ )

**Syntax**

```
yi = griddatan(x,y,xi)
yi = griddatan(x,y,xi,method)
yi = griddatan(x,y,xi,method,options)
```

**Description** `yi = griddatan(x,y,xi)` fits a hyper-surface of the form  $y = f(x)$  to the data in the (usually) nonuniformly-spaced vectors  $(x, y)$ . `griddatan` interpolates this hyper-surface at the points specified by `xi` to produce `yi`. `xi` can be nonuniform.

`X` is of dimension  $m$ -by- $n$ , representing  $m$  points in  $n$ -dimensional space. `y` is of dimension  $m$ -by-1, representing  $m$  values of the hyper-surface  $f(X)$ . `xi` is a vector of size  $p$ -by- $n$ , representing  $p$  points in the  $n$ -dimensional space whose surface value is to be fitted. `yi` is a vector of length  $p$  approximating the values  $f(xi)$ . The hypersurface always goes through the data points  $(X,y)$ . `xi` is usually a uniform grid (as produced by `meshgrid`).

`yi = griddatan(x,y,xi,method)` defines the type of surface fit to the data, where 'method' is one of:

'linear'      Triangulation-based linear interpolation (default)

'nearest'     Nearest neighbor interpolation

All the methods are based on a Delaunay triangulation of the data.

If `method` is `[]`, the default 'linear' method is used.

`yi = griddatan(x,y,xi,method,options)` specifies a cell array of strings `options` to be used in `Qhull` via `delaunayn`.

If `options` is `[]`, the default options are used. If `options` is `{ ' ' }`, no options are used, not even the default.

## Examples **Fit a Hypersurface**

```
X=2*gallery('uniformdata',[5000 3],0)-1;;
Y = sum(X.^2,2);
```

# griddatan

---

```
d = -0.8:0.05:0.8;
[y0,x0,z0] = ndgrid(d,d,d);
XI = [x0(:) y0(:) z0(:)];
YI = griddatan(X,Y,XI);
```

Since it is difficult to visualize 4-D data sets, use isosurface at 0.8:

```
YI = reshape(YI, size(x0));
p = patch(isosurface(x0,y0,z0,YI,0.8));
isonormals(x0,y0,z0,YI,p);
set(p,'FaceColor','blue','EdgeColor','none');
view(3), axis equal, camlight, lighting phong
```

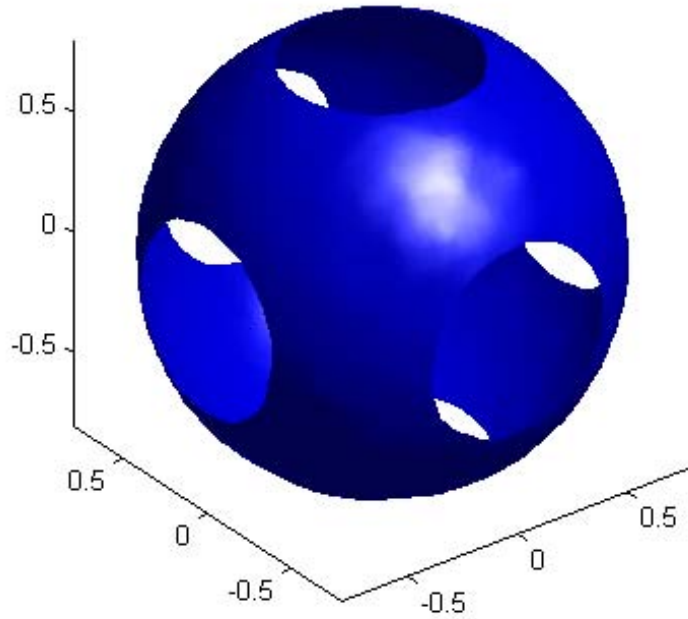

**See Also**

[deilaunayn](#) | [griddata](#) | [meshgrid](#)

# griddedInterpolant

---

## Purpose

Gridded data interpolation

---

**Note** The behavior of `griddedInterpolant` has changed. All interpolation methods now support extrapolation by default. Set `F.ExtrapolationMethod` to 'none' to preserve the pre-R2013a behavior when `F.Method` is 'linear', 'cubic' or 'nearest'. Before R2013a, evaluation returned NaN values at query points outside the domain when `F.Method` was set to 'linear', 'cubic' or 'nearest'.

---

## Description

Use `griddedInterpolant` to perform interpolation on a 1-D, 2-D, 3-D, or N-D “Gridded Data” on page 1-2547 set. For example, you can pass a set of  $(x, y)$  points and values,  $v$ , to `griddedInterpolant`, and it returns a surface of the form  $v = F(x, y)$ . This surface always passes through the sample values at the point locations. You can evaluate this surface at any query point,  $(xq, yq)$ , to produce an interpolated value,  $vq$ .

Use `griddedInterpolant` to create the “Interpolant” on page 1-2547, `F`. Then you can evaluate `F` at specific points using any of the following syntaxes:

- $Vq = F(Xq)$  evaluates `F` at a set of query points in matrix `Xq`. The points in `Xq` are scattered, and each row of `Xq` contains the coordinates of a query point.
- $Vq = F(xq1, xq2, \dots, xqn)$  specifies the query locations,  $xq1, xq2, \dots, xqn$ , as column vectors of length  $m$  representing  $m$  points scattered in  $n$ -dimensional space.
- $Vq = F(Xq1, Xq2, \dots, Xqn)$  specifies the query locations as  $n$   $n$ -dimensional arrays,  $Xq1, Xq2, \dots, Xqn$ , of equal size which define a “Full Grid” on page 1-2547 of points.
- $Vq = F(\{xgq1, xgq2, \dots, xgqn\})$  specifies the query locations as “Grid Vectors” on page 1-2547. Use this syntax to conserve memory when you want to query a large grid of points.



## Construction

`F = griddedInterpolant(x,v)` creates a 1-D interpolant from a vector of sample points, `x`, and corresponding values, `v`.

`F = griddedInterpolant(X1,X2,...,Xn,V)` creates a 2-D, 3-D, or N-D interpolant using a “Full Grid” on page 1-2547 of sample points passed as a set of n-dimensional arrays, `X1,X2,...,Xn`. The `V` array contains the sample values associated with the point locations in `X1,X2,...,Xn`. Each of the arrays, `X1,X2,...,Xn` must be the same size as `V`.

`F = griddedInterpolant(V)` uses the default grid to create the interpolant. When you use this syntax, `griddedInterpolant` defines the grid as set of points whose spacing is 1 and range is `[1, size(V,i)]` in the `i`th dimension. Use this syntax to when you want to conserve memory and are not concerned about the absolute distances between points.

`F = griddedInterpolant({xg1,xg2,...,xgn},V)` specifies n “Grid Vectors” on page 1-2547 to describe an n-dimensional grid of sample points. Use this syntax when you want to use a specific grid and also conserve memory.

`F = griddedInterpolant( __ ,Method)` specifies any of five strings that describe an interpolation method: 'linear', 'nearest', 'pchip', 'cubic', or 'spline'. You can specify `Method` as the last input argument in any of the first four syntaxes.

`F = griddedInterpolant( __ ,Method,ExtrapolationMethod)` specifies both the interpolation and extrapolation methods as strings. `griddedInterpolant` uses `ExtrapolationMethod` to estimate the value when your query points fall outside the domain of your sample points. Specify `Method` and `ExtrapolationMethod` together as the last two input arguments in any of the first four syntaxes.

## Input Arguments

**x**

Sample points vector, specified as a vector of input coordinates the same size as `v`.

**v**

# griddedInterpolant

---

Sample values vector, specified as a vector of input values the same size as  $x$ .

## **$x_1, x_2, \dots, x_n$**

Sample points in “Full Grid” on page 1-2547 form, specified as a set of  $n$ -dimensional arrays. You can create the arrays,  $x_1, x_2, \dots, x_n$ , using the `ndgrid` function. These arrays are all the same size, and each one is the same size as  $V$ .

## **{ $xg_1, xg_2, \dots, xg_n$ }**

Sample points in grid vector form, specified as a cell array of grid vectors. These vectors must specify a grid that is the same size as  $V$ . In other words, `size(V) = [length(xg1) length(xg2), ..., length(xgn)]`. Use this form as an alternative to the full grid to save memory when your grid is very large.

## **$V$**

Sample values, specified as an array. The elements of  $V$  are the values that correspond to the sample points. The size of  $V$  must be the size of the full grid of sample points.

- If you specify the sample points as a full grid consisting of  $N$ -D arrays, then  $V$  must be the same size as any one of:  $x_1, x_2, \dots, x_n$ .
- If you specify the sample points as grid vectors, then `size(V) = [length(xg1) length(xg2) ... length(xgn)]`.

## **Method**

Interpolation method, specified as a string from the table below.

(Continued)

| Method             | Description                                                                                                                                                                                                   | Continuity    | Comments                                                                                                                                                     |
|--------------------|---------------------------------------------------------------------------------------------------------------------------------------------------------------------------------------------------------------|---------------|--------------------------------------------------------------------------------------------------------------------------------------------------------------|
| 'linear' (default) | The interpolated value at a query point is based on linear interpolation of the values at neighboring grid points in each respective dimension.                                                               | $C^0$         | <ul style="list-style-type: none"> <li>• Requires at least 2 grid points in each dimension.</li> <li>• Requires more memory than 'nearest'.</li> </ul>       |
| 'nearest'          | The interpolated value at a query point is the value at the nearest sample grid point.                                                                                                                        | Discontinuous | <ul style="list-style-type: none"> <li>• Requires 2 grid points in each dimension.</li> <li>• Fastest computation with modest memory requirements</li> </ul> |
| 'pchip'            | Shape-preserving piecewise cubic interpolation (for 1-D only). The interpolated value at a query point is based on a shape-preserving piecewise cubic interpolation of the values at neighboring grid points. | $C^1$         | <ul style="list-style-type: none"> <li>• Requires at least 4 points.</li> <li>• Requires more memory and computation time than 'linear'.</li> </ul>          |
| 'cubic'            | The interpolated value at a query point is based on a cubic interpolation of the values at neighboring grid points in each respective dimension. The                                                          | $C^1$         | <ul style="list-style-type: none"> <li>• Grid must have uniform spacing, though the spacing in each dimension does not have to be the same.</li> </ul>       |

# griddedInterpolant

(Continued)

| Method   | Description                                                                                                                                                                                                                    | Continuity | Comments                                                                                                                                                           |
|----------|--------------------------------------------------------------------------------------------------------------------------------------------------------------------------------------------------------------------------------|------------|--------------------------------------------------------------------------------------------------------------------------------------------------------------------|
|          | interpolation is based on a cubic convolution.                                                                                                                                                                                 |            | <ul style="list-style-type: none"><li>• Requires at least 4 points in each dimension.</li><li>• Requires more memory and computation time than 'linear'.</li></ul> |
| 'spline' | The interpolated value at a query point is based on a cubic interpolation of the values at neighboring grid points in each respective dimension. The interpolation is based on a cubic spline using not-a-knot end conditions. | $C^2$      | <ul style="list-style-type: none"><li>• Requires 4 points in each dimension.</li><li>• Requires more memory and computation time than 'cubic'.</li></ul>           |

## ExtrapolationMethod

Extrapolation method, specified as any of the Method choices: 'linear', 'nearest', 'pchip', 'cubic', or 'spline'. In addition, you can specify 'none' if you want queries outside the domain of your grid return NaN values.

If you omit ExtrapolationMethod, the default value is the string you specify for Method. If you omit both the Method and ExtrapolationMethod arguments, both default to 'linear'.

## Properties

### GridVectors

Cell array containing grid vectors, { $xg_1, xg_2, \dots, xg_n$ }. These vectors specify the grid points (locations) for the values in F.Values.

### Values

Array of values associated with the grid points in `F.GridVectors`.

## Method

A string specifying the name of a method used to interpolate the data. Method is one of five strings: 'linear', 'nearest', 'pchip', 'cubic', or 'spline'. The default value is 'linear'.

## ExtrapolationMethod

A string specifying the name of a method used to extrapolate the data. ExtrapolationMethod is one of six strings: 'linear', 'nearest', 'pchip', 'cubic', 'spline', or 'none'. A value of 'none' indicates that extrapolation is disabled. The default value is the value of `F.Method`.

## Definitions

### Interpolant

Interpolating function that you can evaluate at query locations.

### Gridded Data

A set of points that are axis-aligned and ordered.

### Scattered Data

A set of points that have no structure among their relative locations.

### Full Grid

A grid represented as a set of arrays. For example, you can create a full grid using `ndgrid`.

### Grid Vectors

A set of vectors that serve as a compact representation of a grid in `ndgrid` format. For example, `[X,Y] = ndgrid(xg,yg)` returns a full grid in the matrices `X` and `Y`. You can represent the same grid using the grid vectors, `xg` and `yg`.

## Copy Semantics

Value. To learn how value classes affect copy operations, see Copying Objects in the MATLAB documentation.

# griddedInterpolant

---

## Indexing

Index-based editing of the properties of `F` are not supported. Instead, wholly replace the `GridVectors` or `Values` arrays as necessary. See “Interpolation with the `griddedInterpolant` Class” in the MATLAB Mathematics documentation for more information.

## Examples

### 2-D Interpolation Over Finer Grid

Interpolate coarsely sampled data using a full grid with spacing of 0.5.

Define the sample points as a full grid with range [1, 10] in both dimensions.

```
[X,Y] = ndgrid(1:10,1:10);
```

Sample  $f(x,y) = x^2 + y^2$  at the grid points.

```
V = X.^2 + Y.^2;
```

Create the interpolant, specifying cubic interpolation.

```
F = griddedInterpolant(X,Y,V, 'cubic');
```

Define a full grid of query points with 0.5 spacing and evaluate the interpolant at those points. Then plot the result.

```
[Xq,Yq] = ndgrid(1:0.5:10,1:0.5:10);
Vq = F(Xq,Yq);
mesh(Xq,Yq,Vq);
```

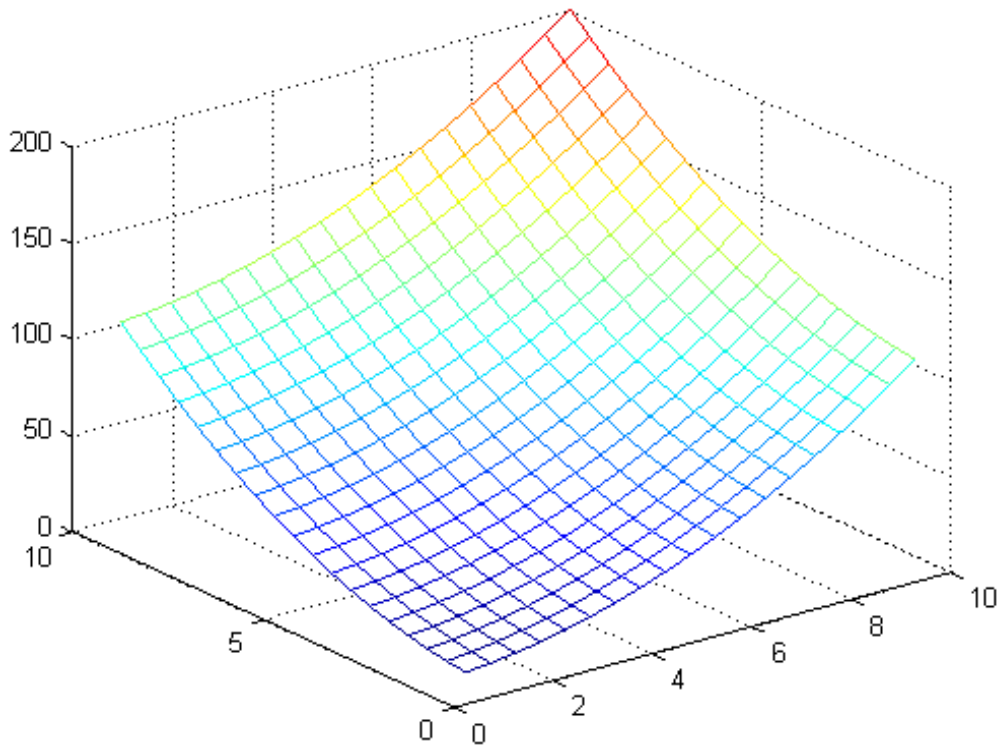

## 1-D Extrapolation

Compare results of querying the interpolant outside the domain of  $F$  using the 'pchip' and 'nearest' extrapolation methods.

Create the interpolant and specify 'pchip' as the interpolation method.

```
x = [1 2 3 4 5];
v = [12 16 31 10 6];
F = griddedInterpolant(x,v,'pchip')
```

# griddedInterpolant

---

```
F =

griddedInterpolant with properties:

 GridVectors: {[1 2 3 4 5]}
 Values: [12 16 31 10 6]
 Method: 'pchip'
 ExtrapolationMethod: 'pchip'
```

Query the interpolant, and include points outside the domain of F.

```
xq = 0:0.1:6;
vq = F(xq);
figure
plot(x,v,'o',xq,vq,'-b');
legend ('v','vq')
```



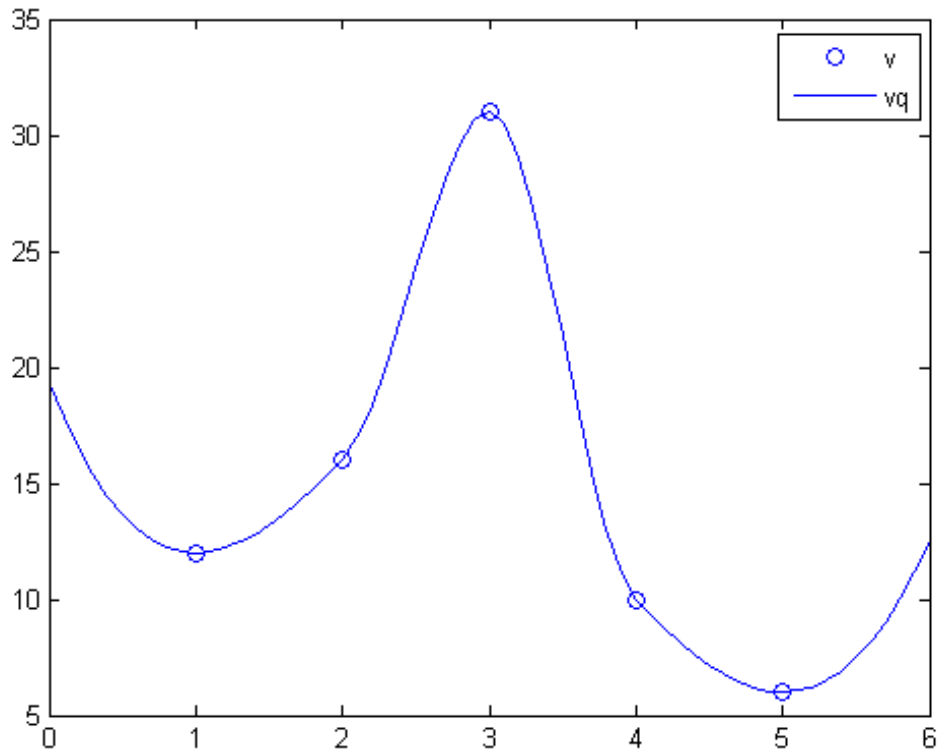

Query the interpolant at the same points again, using the nearest neighbor extrapolation method.

```
F.ExtrapolationMethod = 'nearest';
figure
vq = F(xq);
plot(x,v,'o',xq,vq,'-b');
legend('v','vq')
```

# griddedInterpolant

---

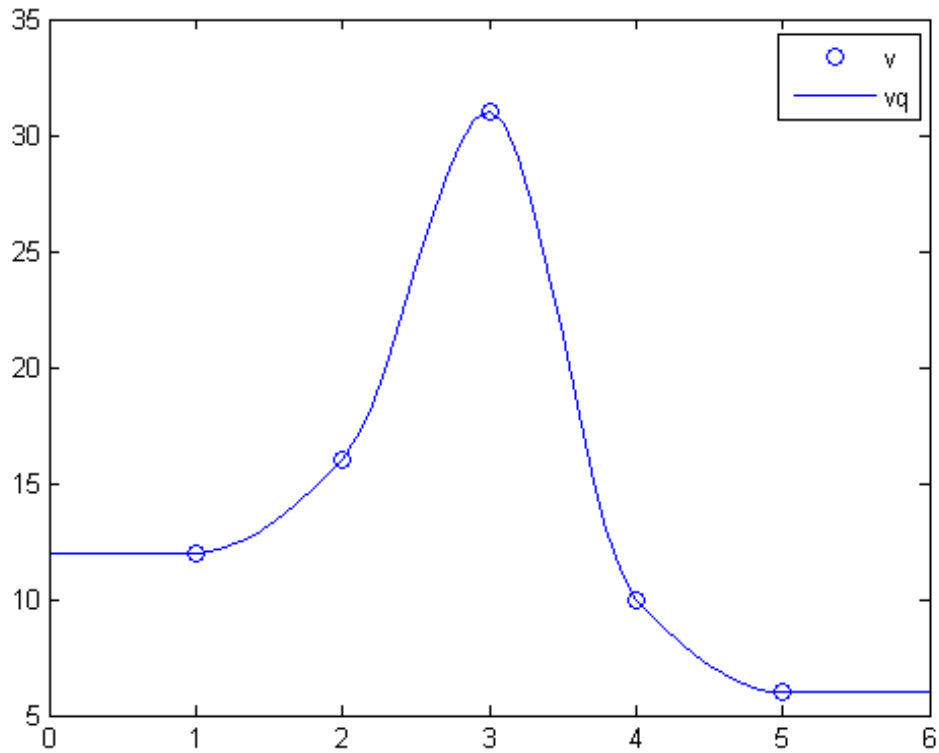

## See Also

[scatteredInterpolant](#) | [interp1](#) | [interp2](#) | [interp3](#) | [interpN](#) | [ndgrid](#) | [meshgrid](#)

## How To

- [Class Attributes](#)
- [Property Attributes](#)
- [“Interpolating Gridded Data”](#)

**Purpose**

Generalized singular value decomposition

**Syntax**

```
[U,V,X,C,S] = gsvd(A,B)
sigma = gsvd(A,B)
```

**Description**

`[U,V,X,C,S] = gsvd(A,B)` returns unitary matrices  $U$  and  $V$ , a (usually) square matrix  $X$ , and nonnegative diagonal matrices  $C$  and  $S$  so that

$$\begin{aligned} A &= U * C * X' \\ B &= V * S * X' \\ C' * C + S' * S &= I \end{aligned}$$

$A$  and  $B$  must have the same number of columns, but may have different numbers of rows. If  $A$  is  $m$ -by- $p$  and  $B$  is  $n$ -by- $p$ , then  $U$  is  $m$ -by- $m$ ,  $V$  is  $n$ -by- $n$  and  $X$  is  $p$ -by- $q$  where  $q = \min(m+n, p)$ .

`sigma = gsvd(A,B)` returns the vector of generalized singular values,  $\sqrt{\text{diag}(C' * C) ./ \text{diag}(S' * S)}$ .

The nonzero elements of  $S$  are always on its main diagonal. If  $m \geq p$  the nonzero elements of  $C$  are also on its main diagonal. But if  $m < p$ , the nonzero diagonal of  $C$  is  $\text{diag}(C, p-m)$ . This allows the diagonal elements to be ordered so that the generalized singular values are nondecreasing.

`gsvd(A,B,0)`, with three input arguments and either  $m$  or  $n \geq p$ , produces the “economy-sized” decomposition where the resulting  $U$  and  $V$  have at most  $p$  columns, and  $C$  and  $S$  have at most  $p$  rows. The generalized singular values are  $\text{diag}(C) ./ \text{diag}(S)$ .

When  $B$  is square and nonsingular, the generalized singular values, `gsvd(A,B)`, are equal to the ordinary singular values, `svd(A/B)`, but they are sorted in the opposite order. Their reciprocals are `gsvd(B,A)`.

In this formulation of the `gsvd`, no assumptions are made about the individual ranks of  $A$  or  $B$ . The matrix  $X$  has full rank if and only if the matrix  $[A;B]$  has full rank. In fact, `svd(X)` and `cond(X)` are equal to `svd([A;B])` and `cond([A;B])`. Other formulations, eg. G. Golub and

C. Van Loan [1], require that  $\text{null}(A)$  and  $\text{null}(B)$  do not overlap and replace  $X$  by  $\text{inv}(X)$  or  $\text{inv}(X')$ .

Note, however, that when  $\text{null}(A)$  and  $\text{null}(B)$  do overlap, the nonzero elements of  $C$  and  $S$  are not uniquely determined.

## Examples

### Example 1

The matrices have at least as many rows as columns.

```
A = reshape(1:15,5,3)
```

```
B = magic(3)
```

```
A =
```

```
 1 6 11
 2 7 12
 3 8 13
 4 9 14
 5 10 15
```

```
B =
```

```
 8 1 6
 3 5 7
 4 9 2
```

The statement

```
[U,V,X,C,S] = gsvd(A,B)
```

produces a 5-by-5 orthogonal  $U$ , a 3-by-3 orthogonal  $V$ , a 3-by-3 nonsingular  $X$ ,

```
X =
```

```
 2.8284 -9.3761 -6.9346
 -5.6569 -8.3071 -18.3301
 2.8284 -7.2381 -29.7256
```

and

```
C =
```

```
 0.0000 0 0
```

$$S = \begin{bmatrix} 0 & 0.3155 & 0 \\ 0 & 0 & 0.9807 \\ 0 & 0 & 0 \\ 0 & 0 & 0 \\ 1.0000 & 0 & 0 \\ 0 & 0.9489 & 0 \\ 0 & 0 & 0.1957 \end{bmatrix}$$

Since A is rank deficient, the first diagonal element of C is zero.

The economy sized decomposition,

$$[U, V, X, C, S] = \text{gsvd}(A, B, 0)$$

produces a 5-by-3 matrix U and a 3-by-3 matrix C.

$$U = \begin{bmatrix} 0.5700 & -0.6457 & -0.4279 \\ -0.7455 & -0.3296 & -0.4375 \\ -0.1702 & -0.0135 & -0.4470 \\ 0.2966 & 0.3026 & -0.4566 \\ 0.0490 & 0.6187 & -0.4661 \end{bmatrix}$$

$$C = \begin{bmatrix} 0.0000 & 0 & 0 \\ 0 & 0.3155 & 0 \\ 0 & 0 & 0.9807 \end{bmatrix}$$

The other three matrices, V, X, and S are the same as those obtained with the full decomposition.

The generalized singular values are the ratios of the diagonal elements of C and S.

$$\begin{aligned} \text{sigma} &= \text{gsvd}(A, B) \\ \text{sigma} &= \begin{bmatrix} 0.0000 \\ 0.3325 \end{bmatrix} \end{aligned}$$

5.0123

These values are a reordering of the ordinary singular values

```
svd(A/B)
ans =
 5.0123
 0.3325
 0.0000
```

## Example 2

The matrices have at least as many columns as rows.

```
A = reshape(1:15,3,5)
B = magic(5)
A =
```

|   |   |   |    |    |
|---|---|---|----|----|
| 1 | 4 | 7 | 10 | 13 |
| 2 | 5 | 8 | 11 | 14 |
| 3 | 6 | 9 | 12 | 15 |

```
B =
```

|    |    |    |    |    |
|----|----|----|----|----|
| 17 | 24 | 1  | 8  | 15 |
| 23 | 5  | 7  | 14 | 16 |
| 4  | 6  | 13 | 20 | 22 |
| 10 | 12 | 19 | 21 | 3  |
| 11 | 18 | 25 | 2  | 9  |

The statement

```
[U,V,X,C,S] = gsvd(A,B)
```

produces a 3-by-3 orthogonal U, a 5-by-5 orthogonal V, a 5-by-5 nonsingular X and

```
C =
```

```

 0 0 0.0000 0 0
 0 0 0 0.0439 0
 0 0 0 0 0.7432

```

S =

```

 1.0000 0 0 0 0
 0 1.0000 0 0 0
 0 0 1.0000 0 0
 0 0 0 0.9990 0
 0 0 0 0 0.6690

```

In this situation, the nonzero diagonal of C is  $\text{diag}(C,2)$ . The generalized singular values include three zeros.

```

sigma = gsvd(A,B)
sigma =

```

```

 0
 0
 0.0000
 0.0439
 1.1109

```

Reversing the roles of A and B reciprocates these values, producing two infinities.

```

gsvd(B,A)
ans =

```

```

 1.0e+16 *
 0.0000
 0.0000
 8.8252
 Inf
 Inf

```

## Algorithms

The generalized singular value decomposition uses the C-S decomposition described in [1], as well as the built-in `svd` and `qr` functions. The C-S decomposition is implemented in a local function in the `gsvd` program file.

## Diagnostics

The only warning or error message produced by `gsvd` itself occurs when the two input arguments do not have the same number of columns.

## References

[1] Golub, Gene H. and Charles Van Loan, *Matrix Computations*, Third Edition, Johns Hopkins University Press, Baltimore, 1996

## See Also

`qr` | `svd`



|                        |                                                                                                                                                                                                                                                                                                                                                                                                                                                                                                                                                                                                                                                                                                                                                                                                                                                                                                                                                                                                                                                                                                                                                                                   |
|------------------------|-----------------------------------------------------------------------------------------------------------------------------------------------------------------------------------------------------------------------------------------------------------------------------------------------------------------------------------------------------------------------------------------------------------------------------------------------------------------------------------------------------------------------------------------------------------------------------------------------------------------------------------------------------------------------------------------------------------------------------------------------------------------------------------------------------------------------------------------------------------------------------------------------------------------------------------------------------------------------------------------------------------------------------------------------------------------------------------------------------------------------------------------------------------------------------------|
| <b>Purpose</b>         | Determine greater than                                                                                                                                                                                                                                                                                                                                                                                                                                                                                                                                                                                                                                                                                                                                                                                                                                                                                                                                                                                                                                                                                                                                                            |
| <b>Syntax</b>          | $A > B$<br>gt(A,B)                                                                                                                                                                                                                                                                                                                                                                                                                                                                                                                                                                                                                                                                                                                                                                                                                                                                                                                                                                                                                                                                                                                                                                |
| <b>Description</b>     | <p><math>A &gt; B</math> returns a logical array with elements set to logical 1 (true) where A is greater than B; otherwise, it returns logical 0 (false). The test compares only the real part of numeric arrays. <code>gt</code> returns logical 0 (false) where A or B have NaN or undefined categorical elements.</p> <p><code>gt(A,B)</code> is an alternate way to execute <math>A &gt; B</math>, but is rarely used. It enables operator overloading for classes.</p>                                                                                                                                                                                                                                                                                                                                                                                                                                                                                                                                                                                                                                                                                                      |
| <b>Input Arguments</b> | <p><b>A - Left array</b><br/>numeric array   logical array   character array   ordinal categorical array</p> <p>Left array, specified as a numeric array, logical array, character array, or categorical array. Inputs <b>A</b> and <b>B</b> must be the same size unless one is a scalar. A scalar input expands into an array of the same size as the other input.</p> <p>If one input is an ordinal categorical array, the other input can be an ordinal categorical array, a cell array of strings, or a single string. A single string expands into a cell array of strings of the same size as the other input. If both inputs are ordinal categorical arrays, they must have the same sets of categories, including their order. See “Compare Categorical Array Elements” for more details.</p> <p><b>B - Right array</b><br/>numeric array   logical array   character array   ordinal categorical array</p> <p>Right array, specified as a numeric array, logical array, character array, or categorical array. Inputs <b>A</b> and <b>B</b> must be the same size unless one is a scalar. A scalar input expands into an array of the same size as the other input.</p> |

If one input is an ordinal categorical array, the other input can be an ordinal categorical array, a cell array of strings, or a single string. A single string expands into a cell array of strings of the same size as the other input. If both inputs are ordinal categorical arrays, they must have the same sets of categories, including their order. See “Compare Categorical Array Elements” for more details.

## Examples

### Test Vector Elements

Determine if vector elements are greater than a given value.

Create a numeric vector.

```
A = [1 12 18 7 9 11 2 15];
```

Test the vector for elements that are greater than 10.

```
A > 10
```

```
ans =
```

```
0 1 1 0 0 1 0 1
```

The result is a vector with values of logical 1 (true) where the elements of A satisfy the expression.

Use the vector of logical values as an index to view the values in A that are greater than 10.

```
A(A > 10)
```

```
ans =
```

```
12 18 11 15
```

The result is a subset of the elements in A.

## Replace Elements of Matrix

Create a matrix.

```
A = magic(4)
```

```
A =
```

```
 16 2 3 13
 5 11 10 8
 9 7 6 12
 4 14 15 1
```

Replace all values greater than 9 with the value 10.

```
A(A > 9) = 10
```

```
A =
```

```
 10 2 3 10
 5 10 10 8
 9 7 6 10
 4 10 10 1
```

The result is a new matrix whose largest element is 10.

## Compare Values in Categorical Array

Create an ordinal categorical array.

```
A = categorical({'large' 'medium' 'small'; 'medium' ...
 'small' 'large'},{'small' 'medium' 'large'},'Ordinal',1)
```

```
A =
```

```
 large medium small
 medium small large
```

The array has three categories: 'small', 'medium', and 'large'.

Find all values greater than the category 'medium'.

```
A > 'medium'
```

```
ans =
```

```
 1 0 0
 0 0 1
```

A value of logical 1 (true) indicates a value greater than the category 'medium'.

Compare the rows of A.

```
A(1,:) > A(2,:)
```

```
ans =
```

```
 1 1 0
```

The function returns logical 1 (true) where the first row has a category value greater than the second row.

### **Test Complex Numbers**

Create a vector of complex numbers.

```
A = [1+i 2-2i 1+3i 1-2i 5-i];
```

Find the values that are greater than 2.

```
A(A > 2)
```

```
ans =
```

```
5.0000 - 1.0000i
```

gt compares only the real part of the elements in A.

Use abs to find which elements are outside a radius of 2 from the origin.

```
A(abs(A) > 2)
```

```
ans =
```

```
2.0000 - 2.0000i 1.0000 + 3.0000i 1.0000 - 2.0000i 5.0000 - 1.0000i
```

The result has more elements since `abs` accounts for the imaginary part of the numbers.

**See Also**

`eq` | `ge` | `lt` | `le` | `ne`

**Concepts**

- “Ordinal Categorical Arrays”

# gtext

---

## Purpose

Mouse placement of text in 2-D view

## Syntax

```
gtext('string')
gtext({'string1','string2','string3',...})
gtext({'string1';'string2';'string3';...})
gtext(...,'PropertyName',PropertyValue,...)
h = gtext(...)
```

## Description

`gtext` displays a text string in the current figure window after you select a location with the mouse.

`gtext('string')` waits for you to press a mouse button or keyboard key while the pointer is within a figure window. Pressing a mouse button or any key places *string* on the plot at the selected location.

`gtext({'string1','string2','string3',...})` places all strings with one click, each on a separate line.

`gtext({'string1';'string2';'string3';...})` places one string per click, in the sequence specified.

`gtext(...,'PropertyName',PropertyValue,...)` sets the values of the specified text properties. For a list of properties, see [Text Properties](#).

`h = gtext(...)` returns the handle to a text graphics object that is placed on the plot at the location you select.

## Tips

As you move the pointer into a figure window, the pointer becomes crosshairs to indicate that `gtext` is waiting for you to select a location. `gtext` uses the functions `ginput` and `text`.

## Examples

Place a label on the current plot:

```
gtext('Note this divergence!')
```

## See Also

[ginput](#) | [text](#)

**Purpose** Store or retrieve GUI data

**Syntax** `guidata(object_handle,data)`  
`data = guidata(object_handle)`

**Description** `guidata(object_handle,data)` stores the variable `data` as GUI data. If `object_handle` is not a figure handle, then the object's parent figure is used. `data` can be any MATLAB variable, but is typically a structure, which enables you to add new fields as required.

`guidata` can manage only one variable at any time. Subsequent calls to `guidata(object_handle,data)` overwrite the previously created version of GUI data.

---

### **GUIDE Uses guidata**

GUIDE uses `guidata` to store and maintain the `handles` structure. In a GUIDE GUI code file, do not overwrite the `handles` structure or your GUI will no longer work. If you need to store data other than `handles` for your GUI, you can add new fields to the `handles` structure and safely place your data there.

---

`data = guidata(object_handle)` returns previously stored data, or an empty matrix if nothing is stored.

To change the data managed by `guidata`:

- 1 Get a copy of the data with the command `data = guidata(object_handle)`.
- 2 Make the desired changes to `data`.
- 3 Save the changed version of `data` with the command `guidata(object_handle,data)`.

`guidata` provides application developers with a convenient interface to a figure's application data:

- You do not need to create and maintain a hard-coded property name for the application data throughout your source code.
- You can access the data from within a local function callback routine using the component's handle (which is returned by `gcb0`), without needing to find the figure's handle.

If you are not using GUIDE, `guidata` is particularly useful in conjunction with `guihandles`, which creates a structure containing the handles of all the components in a GUI.

## Examples

This example calls `guidata` to save a structure containing a GUI figure's application data from within the initialization section of the application code file. The first section shows how to do this within a GUI you create manually. The second section shows how the code differs when you use GUIDE to create a template code file. GUIDE provides a `handles` structure as an argument to all local function callbacks, so you do not need to call `guidata` to obtain it. You do, however, need to call `guidata` to save changes you make to the structure.

### Using guidata in a Programmed GUI

Calling the `guihandles` function creates the structure into which your code places additional data. It contains all handles used by the figure at the time it is called, generating field names based on each object's `Tag` property.

```
% Create figure to use as GUI in your main function or a local function
figure_handle = figure('Toolbar','none');
% create structure of handles
myhandles = guihandles(figure_handle);
% Add some additional data as a new field called numberOfErrors
myhandles.numberOfErrors = 0;
% Save the structure
guidata(figure_handle,myhandles)
```



You can recall the data from within a local callback function, modify it, and then replace the structure in the figure:

```
function My_Callback()
% ...
% Get the structure using guidata in the local function
myhandles = guidata(gcbo);
% Modify the value of your counter
myhandles.numberOfErrors = myhandles.numberOfErrors + 1;
% Save the change you made to the structure
guidata(gcbo,myhandles)
```

## Using guidata in a GUIDE GUI

If you use GUIDE, you do not need to call `guihandles` to create a structure, because GUIDE generates a `handles` structure that contains the GUI's handles. You can add your own data to it, for example from within the `OpeningFcn` template that GUIDE creates:

```
% --- Executes just before simple_gui_tab is made visible.
function my_GUIDE_GUI_OpeningFcn(hObject, eventdata, handles, varargin)
% This function has no output args, see OutputFcn.
% hObject handle to figure
% eventdata reserved - to be defined in a future version of MATLAB
% handles structure with handles and user data (see GUIDATA)
% varargin command line arguments to simple_gui_tab (see VARARGIN)
% ...

% add some additional data as a new field called numberOfErrors
handles.numberOfErrors = 0;
% Save the change you made to the structure
guidata(hObject,handles)
```

Notice that you use the input argument `hObject` in place of `gcbo` to refer to the object whose callback is executing.

Suppose you needed to access the `numberOfErrors` field in a push button callback. Your callback code now looks something like this:

# guidata

---

```
% --- Executes on button press in pushbutton1.
function my_GUIDE_GUI_pushbutton1_Callback(hObject, eventdata, handles)
% hObject handle to pushbutton1 (see GCBO)
% eventdata reserved - to be defined in a future version of MATLAB
% handles structure with handles and user data (see GUIDATA)
% ...

% No need to call guidata to obtain a structure;
% it is provided by GUIDE via the handles argument
handles.numberofErrors = handles.numberofErrors + 1;
% save the changes to the structure
guidata(hObject,handles)
```

## See Also

[guide](#) | [guihandles](#) | [getappdata](#) | [setappdata](#)

---

|                    |                                                                                                                                                                                                                                                                                                                                                                                                                                                                                                                                                                                                                                                                                                                                           |
|--------------------|-------------------------------------------------------------------------------------------------------------------------------------------------------------------------------------------------------------------------------------------------------------------------------------------------------------------------------------------------------------------------------------------------------------------------------------------------------------------------------------------------------------------------------------------------------------------------------------------------------------------------------------------------------------------------------------------------------------------------------------------|
| <b>Purpose</b>     | Open GUI Layout Editor                                                                                                                                                                                                                                                                                                                                                                                                                                                                                                                                                                                                                                                                                                                    |
| <b>Syntax</b>      | <pre>guide guide('filename.fig') guide('fullpath') guide(HandleList)</pre>                                                                                                                                                                                                                                                                                                                                                                                                                                                                                                                                                                                                                                                                |
| <b>Description</b> | <p><code>guide</code> initiates the GUI design environment (GUIDE) tools that allow you to create or edit GUIs interactively.</p> <p><code>guide</code> opens the GUIDE Quick Start dialog where you can choose to open a previously created GUI or create a new one using one of the provided templates.</p> <p><code>guide('filename.fig')</code> opens the FIG-file named <code>filename.fig</code> for editing if it is on the MATLAB path.</p> <p><code>guide('fullpath')</code> opens the FIG-file at <code>fullpath</code> even if it is not on the MATLAB path.</p> <p><code>guide(HandleList)</code> opens the content of each of the figures in <code>HandleList</code> in a separate copy of the GUIDE design environment.</p> |
| <b>See Also</b>    | <code>inspect</code>                                                                                                                                                                                                                                                                                                                                                                                                                                                                                                                                                                                                                                                                                                                      |
| <b>How To</b>      | <ul style="list-style-type: none"><li>• “Ways to Build MATLAB GUIs”</li><li>• “Create a Simple GUIDE GUP”</li></ul>                                                                                                                                                                                                                                                                                                                                                                                                                                                                                                                                                                                                                       |

# guihandles

---

**Purpose** Create structure of handles

**Syntax** `handles = guihandles(object_handle)`  
`handles = guihandles`

**Description** `handles = guihandles(object_handle)` returns a structure containing the handles of the objects in a figure, using the value of their Tag properties as the field names, with the following caveats:

- Objects are excluded if their Tag properties are empty, or are not legal variable names.
- If several objects have the same Tag, that field in the structure contains a vector of handles.
- Objects with hidden handles are included in the structure.

`handles = guihandles` returns a structure of handles for the current figure.

**See Also** `guidata` | `guide` | `getappdata` | `setappdata`

**Purpose** Uncompress GNU zip files

**Syntax**

```
gunzip(files)
gunzip(files,outputdir)
gunzip(url, ...)
filenames = gunzip(...)
```

**Description** `gunzip(files)` uncompresses GNU zip files from the list of files specified in `files`. Directories recursively `gunzip` all of their content. The output files have the same name, excluding the extension `.gz`, and are written to the same directory as the input files.

`files` is a string or cell array of strings containing a list of files or directories. Individual files that are on the MATLAB path can be specified as partial path names. Otherwise, an individual file can be specified relative to the current directory or with an absolute path.

Folders must be specified relative to the current folder or with absolute paths. On UNIX systems, folders can also start with `~/` or `~username/`, which expands to the current user's home folder or the specified user's home folder, respectively. The wildcard character `*` can be used when specifying files or folders, except when relying on the MATLAB path to resolve a file name or partial path name.

`gunzip(files,outputdir)` writes the gunzipped file into the directory `outputdir`. If `outputdir` does not exist, MATLAB creates it.

`gunzip(url, ...)` extracts the GNU zip contents from an Internet universal resource locator (URL). The URL must include the protocol type (for example, `'http://'`). MATLAB downloads the URL to the temp directory, and then deletes it.

`filenames = gunzip(...)` gunzips the files and returns the relative path names of the gunzipped files in the string cell array `filenames`.

**Examples** To `gunzip` all `.gz` files in the current directory, type:

```
gunzip('*.*.gz');
```

# gunzip

---

To `gunzip` Cleve Moler's "Numerical Computing with MATLAB" examples to the output directory `ncm`, type:

```
url = 'http://www.mathworks.com/moler/ncm.tar.gz';
gunzip(url, 'ncm')
untar('ncm/ncm.tar', 'ncm')
```

## See Also

`gzip` | `tar` | `untar` | `unzip` | `zip`

---

|                    |                                                                                                                                                                                                                                                                                                                                                                                                                                                                                                                                                                                                                                                                                                                                                                                                                                                                                                                                                                                                                                                                                                                                                                                                                                                                                                                                                                                                                                                 |
|--------------------|-------------------------------------------------------------------------------------------------------------------------------------------------------------------------------------------------------------------------------------------------------------------------------------------------------------------------------------------------------------------------------------------------------------------------------------------------------------------------------------------------------------------------------------------------------------------------------------------------------------------------------------------------------------------------------------------------------------------------------------------------------------------------------------------------------------------------------------------------------------------------------------------------------------------------------------------------------------------------------------------------------------------------------------------------------------------------------------------------------------------------------------------------------------------------------------------------------------------------------------------------------------------------------------------------------------------------------------------------------------------------------------------------------------------------------------------------|
| <b>Purpose</b>     | Compress files into GNU zip files                                                                                                                                                                                                                                                                                                                                                                                                                                                                                                                                                                                                                                                                                                                                                                                                                                                                                                                                                                                                                                                                                                                                                                                                                                                                                                                                                                                                               |
| <b>Syntax</b>      | <pre>gzip(files) gzip(files,outputdir) filenames = gzip(...)</pre>                                                                                                                                                                                                                                                                                                                                                                                                                                                                                                                                                                                                                                                                                                                                                                                                                                                                                                                                                                                                                                                                                                                                                                                                                                                                                                                                                                              |
| <b>Description</b> | <p><code>gzip(files)</code> creates GNU zip files from the list of files specified in <code>files</code>. Directories recursively <code>gzip</code> all their contents. Each output gzipped file is written to the same directory as the input file and with the file extension <code>.gz</code>.</p> <p><code>files</code> is a string or cell array of strings containing a list of files or directories to <code>gzip</code>. Individual files that are on the MATLAB path can be specified as partial path names. Otherwise, an individual file can be specified relative to the current directory or with an absolute path.</p> <p>Folders must be specified relative to the current folder or with absolute paths. On UNIX systems, folders can also start with <code>~/</code> or <code>~username/</code>, which expands to the current user's home folder or the specified user's home folder, respectively. The wildcard character <code>*</code> can be used when specifying files or folders, except when relying on the MATLAB path to resolve a file name or partial path name.</p> <p><code>gzip(files,outputdir)</code> writes the gzipped files into the directory <code>outputdir</code>. If <code>outputdir</code> does not exist, MATLAB creates it.</p> <p><code>filenames = gzip(...)</code> gzips the files and returns the relative path names of all gzipped files in the string cell array <code>filenames</code>.</p> |
| <b>Examples</b>    | <p>To <code>gzip</code> all <code>.m</code> and <code>.mat</code> files in the current directory and store the results in the directory <code>archive</code>, type:</p> <pre>gzip({'*.m','*.mat'},'archive');</pre>                                                                                                                                                                                                                                                                                                                                                                                                                                                                                                                                                                                                                                                                                                                                                                                                                                                                                                                                                                                                                                                                                                                                                                                                                             |
| <b>See Also</b>    | <code>gunzip</code>   <code>tar</code>   <code>untar</code>   <code>unzip</code>   <code>zip</code>                                                                                                                                                                                                                                                                                                                                                                                                                                                                                                                                                                                                                                                                                                                                                                                                                                                                                                                                                                                                                                                                                                                                                                                                                                                                                                                                             |

# h5create

---

**Purpose** Create HDF5 data set

**Syntax** `h5create(filename,datasetname,size,Name,Value)`

**Description** `h5create(filename,datasetname,size,Name,Value)` creates an HDF5 data set in the file specified by `filename`.

## Input Arguments

### **filename**

Text string specifying the name of an HDF5 file. If `filename` does not already exist, `h5create` creates it, with additional options specified by one or more `Name,Value` pair arguments.

### **datasetname**

Text string specifying the name of the data set you want to create. If `datasetname` is a full path name, `h5create` creates all intermediate groups, if they don't already exist.

### **size**

Array specifying the extents of the dataset. To specify an unlimited extent, set the corresponding element of `size` to `Inf`.

## Name-Value Pair Arguments

Specify optional comma-separated pairs of `Name,Value` arguments. `Name` is the argument name and `Value` is the corresponding value. `Name` must appear inside single quotes ( ' '). You can specify several name and value pair arguments in any order as `Name1,Value1,...,NameN,ValueN`.

### **Datatype**

Any of the following MATLAB datatypes.

|        |        |        |        |       |
|--------|--------|--------|--------|-------|
| double | uint64 | uint32 | uint16 | uint8 |
| single | int64  | int32  | int16  | int8  |



**Default:** double

## **ChunkSize**

Defines chunking layout.

**Default:** Not chunked

## **Deflate**

Defines gzip compression level (0-9).

**Default:** 0

## **FillValue**

Defines the fill value for numeric data sets.

## **Fletcher32**

Turns on the Fletcher32 checksum filter.

**Default:** false

## **Shuffle**

Turns on the Shuffle filter.

**Default:** false

## **Examples**

Create a fixed-size 100-by-200 data set.

```
h5create('myfile.h5', '/myDataset1', [100 200]);
h5disp('myfile.h5');
```

---

Create a single-precision 1000-by-2000 data set with a chunk size of 50-by-80. Apply the highest level of compression.

# h5create

---

```
h5create('myfile.h5', '/myDataset2', [1000 2000], 'Datatype', 'single', ...
 'ChunkSize', [50 80], 'Deflate', 9);
h5disp('myfile.h5');
```

---

Create a two-dimensional data set that is unlimited along the second extent.

```
h5create('myfile.h5', '/myDataset3', [200 Inf], 'ChunkSize', [20 20]);
h5disp('myfile.h5');
```

## See Also

[h5read](#) | [h5write](#) | [h5info](#) | [h5disp](#)

## Tutorials

- “Exporting to HDF5 Files”

**Purpose** Display contents of HDF5 file

**Syntax**  
h5disp(filename)  
h5disp(filename,location)  
h5disp(filename,location,mode)

**Description**  
h5disp(filename) displays the structure (metadata) of the entire HDF5 file, filename.  
h5disp(filename,location) displays the metadata for the specified location.  
h5disp(filename,location,mode) displays the file metadata according to the value of mode.

## Input Arguments

### filename

Text string specifying the name of an HDF5 file.

### location

Text string specifying the full path to a location in an HDF5 file. To display the metadata for the entire file, specify '/' as the value of location. If location is a group, h5disp displays all objects below the group.

### mode

Either of the following text strings.

| Value  | Description                                                                                                         |
|--------|---------------------------------------------------------------------------------------------------------------------|
| min    | Minimal, display only group and data set names.                                                                     |
| simple | Display data set metadata and attribute values, if the attribute is an integer, floating point, or a scalar string. |

**Default:** simple

# h5disp

---

## Examples

Display the entire contents of an HDF5 file.

```
h5disp('example.h5')
```

---

Display metadata for one data set in an HDF5 file.

```
h5disp('example.h5', '/g4/world');
```

## See Also

`h5info`

## Tutorials

- “Using the High-Level HDF5 Functions to Import Data”

**Purpose**

Return information about HDF5 file

**Syntax**

```
info = h5info(filename)
info = h5info(filename,location)
```

**Description**

`info = h5info(filename)` returns information about the entire HDF5 file, specified by `filename`.

`info = h5info(filename,location)` returns information about the group, data set, or named datatype specified by `location` in the HDF5 file, `filename`.

**Input Arguments****filename**

Text string specifying the name of an HDF5 file.

**location**

Text string specifying the location of a group, data set, or named datatype in an HDF5 file.

**Output Arguments****info**

A structure containing information about the HDF5 file. The set of fields in the structure depends on the `location` parameter. The first field is always 'Filename'. Other fields that might be present in the `info` structure are as follows.

| Location Type    | Field | Description                                                                                    |
|------------------|-------|------------------------------------------------------------------------------------------------|
| Files and Groups |       |                                                                                                |
|                  | Name  | Text string specifying name of the group. If you specify only a file name, this value is '/ '. |

| Location Type   | Field      | Description                                                                          |
|-----------------|------------|--------------------------------------------------------------------------------------|
|                 | Groups     | Array of structures describing subgroups.                                            |
|                 | Datasets   | Array of structures describing data sets.                                            |
|                 | Datatypes  | Array of structures describing named datatypes.                                      |
|                 | Links      | Array of structures describing soft, external, user-defined, and certain hard links. |
|                 | Attributes | Array of structures describing group attributes.                                     |
| Data sets       |            |                                                                                      |
|                 | Name       | Text string specifying the name of the data set.                                     |
|                 | Datatype   | Structure describing the datatype.                                                   |
|                 | Dataspace  | Structure describing the size of the dataset.                                        |
|                 | ChunkSize  | Extents of the data set's chunk size, if defined.                                    |
|                 | FillValue  | Data set's fill value, if defined.                                                   |
|                 | Filter     | Array of structures describing any defined filters such as compression.              |
|                 | Attributes | Array of structures describing data set attributes.                                  |
| Named Datatypes |            |                                                                                      |

| Location Type | Field | Description                                             |
|---------------|-------|---------------------------------------------------------|
|               | Name  | Text string specifying the name of the datatype object. |
|               | Class | HDF5 class of the named datatype.                       |
|               | Type  | Text string or struct further describing the datatype.  |
|               | Size  | Size of the named datatype in bytes.                    |

## Examples

Return all information.

```
info = h5info('example.h5');
```

---

Return information about a group and all data sets contained within the group.

```
info = h5info('example.h5', '/g4');
```

---

Return information about a specific dataset.

```
info = h5info('example.h5', '/g4/time');
```

## See Also

`h5disp`

## Tutorials

- “Using the High-Level HDF5 Functions to Import Data”

# h5read

---

**Purpose** Read data from HDF5 data set

**Syntax**

```
data = h5read(filename,datasetname)
data = h5read(filename,datasetname,start,count)
data = h5read(filename,datasetname,start,count,stride)
```

**Description** `data = h5read(filename,datasetname)` retrieves all of the data from the HDF5 data set `datasetname` in the file `filename`.

`data = h5read(filename,datasetname,start,count)` reads a subset of data from the data set `datasetname`. `start` is the one-based index of the first element to be read. `count` defines how many elements to read along each dimension. If a particular element of `count` is `Inf`, `h5read` reads data until the end of the corresponding dimension.

`data = h5read(filename,datasetname,start,count,stride)` reads a subset of data, where `stride` specifies the interelement spacing along each data set extent.

## Input Arguments

### **filename**

Text string specifying the name of an HDF5 file.

### **datasetname**

Text string specifying the name of a data set in an HDF5 file.

### **start**

Numeric index value specifying the place to start reading data in the dataset in an HDF5 file. Indices are 1-based.

### **count**

Numeric value specifying the amount of data to read.

### **stride**



Numeric value specifying the interval spacing during the read operation. For example, a spacing of 2 indicates reading every other value.

## Output Arguments

### **data**

Data read from the data set.

## Examples

Read an entire data set.

```
h5disp('example.h5','/g4/lat');
data = h5read('example.h5','/g4/lat');
```

---

Read the first 5-by-3 subset of a data set.

```
h5disp('example.h5','/g4/world');
data = h5read('example.h5','/g4/world',[1 1],[5 3]);
```

---

Read a data set of references to other data sets.

```
h5disp('example.h5','/g3/reference');
data = h5read('example.h5','/g3/reference');
```

## See Also

[h5write](#) | [h5readatt](#) | [h5disp](#) | [h5writeatt](#)

## Tutorials

- “Using the High-Level HDF5 Functions to Import Data”

# h5readatt

---

|                         |                                                                                                                                                                                                                                                                                                                      |
|-------------------------|----------------------------------------------------------------------------------------------------------------------------------------------------------------------------------------------------------------------------------------------------------------------------------------------------------------------|
| <b>Purpose</b>          | Read attribute from HDF5 file                                                                                                                                                                                                                                                                                        |
| <b>Syntax</b>           | <code>attval = h5readatt(filename,location,attr)</code>                                                                                                                                                                                                                                                              |
| <b>Description</b>      | <code>attval = h5readatt(filename,location,attr)</code> retrieves the value for the named attribute <code>attr</code> from the given location in the HDF5 file <code>filename</code> .                                                                                                                               |
| <b>Input Arguments</b>  | <b>filename</b><br>Text string specifying the name of an HDF5 file.<br><b>location</b><br>Text string specifying the full path of the attribute in an HDF5 file. <code>location</code> can refer to either a group or a data set.<br><b>attr</b><br>Text string specifying the name of an attribute in an HDF5 file. |
| <b>Output Arguments</b> | <b>attval</b><br>Value of the attribute.                                                                                                                                                                                                                                                                             |
| <b>Examples</b>         | Read a group attribute.<br><pre>attval = h5readatt('example.h5','/', 'attr2');</pre> <hr/> Read a data set attribute.<br><pre>attval = h5readatt('example.h5','/g4/lon', 'units');</pre>                                                                                                                             |
| <b>See Also</b>         | <code>h5writeatt</code>   <code>h5info</code>                                                                                                                                                                                                                                                                        |
| <b>Tutorials</b>        | <ul style="list-style-type: none"><li>• “Using the High-Level HDF5 Functions to Import Data”</li></ul>                                                                                                                                                                                                               |

**Purpose**

Write to HDF5 data set

**Syntax**

```
h5write(filename,datasetname,data)
h5write(filename,datasetname,data,start,count)
h5write(filename,datasetname,data,start,count,stride)
```

**Description**

`h5write(filename,datasetname,data)` writes data to an entire data set, `datasetname`, in the HDF5 file, `filename`.

`h5write(filename,datasetname,data,start,count)` writes a subset of the data to a data set, `datasetname`, in the HDF5 file, `filename`. `start` is a one-based index value that specifies the first element to be written. `count` specifies the number of elements to write along each dimension. `h5write` extends an extendable data set along any unlimited dimensions, if necessary.

`h5write(filename,datasetname,data,start,count,stride)` writes a hyperslab of data, where `stride` specifies the inter-element spacing along each dimension.

**Input Arguments****filename**

Text string specifying the name of an HDF5 file.

**datasetname**

Text string specifying the name of a data set in the HDF5 file.

**data**

Data to be written to the HDF5 file. You can specify only floating-point and integer data sets.

**start**

Numeric index value specifying where in the data set to start writing to the file.

**count**

# h5write

---

Numeric value specifying how much data to write to the file.

## **stride**

Numeric value specifying the interelement spacing of data to write to the file.

**Default:** Vector of ones.

## **Definitions**

### **Hyperslab**

A hyperslab is a collection of points in a data space. The points can be contiguous or form a regular pattern of points or blocks in a data space.

## **Examples**

Write to an entire data set.

```
h5create('myfile.h5','/DS1',[10 20]);
mydata = rand(10,20);
h5write('myfile.h5','/DS1',mydata);
```

---

Write a hyperslab of data to the last 5-by-7 block of a data set.

```
h5create('myfile.h5','/DS2',[10 20]);
mydata = rand(5,7);
h5write('myfile.h5','/DS2',mydata,[6 14],[5 7]);
```

---

Append data to an unlimited data set.

```
h5create('myfile.h5','/DS3',[20 Inf],'ChunkSize',[5 5]);
for j = 1:10
 data = j*ones(20,1);
 start = [1 j];
 count = [20 1];
 h5write('myfile.h5','/DS3',data,start,count);
end
```

```
h5disp('myfile.h5');
```

**Limitations**

- `h5write` supports only floating point and integer data sets. To write to string data sets, you must use the `H5D` package.

**See Also**

[h5read](#) | [h5create](#) | [h5writeatt](#) | [h5disp](#) | [H5D.create](#) | [H5D.write](#)

**Tutorials**

- “Exporting to HDF5 Files”

# h5writeatt

---

**Purpose** Write HDF5 attribute

**Syntax** `h5writeatt(filename,location,attname,attvalue)`

**Description** `h5writeatt(filename,location,attname,attvalue)` writes the attribute named `attname` with the value `attvalue` to the HDF5 file `filename`. The parent object `location` can be either a group or variable. `location` is the complete path name of the group or variable to which you want to associate the attribute.

## Input Arguments

### **filename**

Text string specifying the name of an HDF5 file.

### **location**

Text string specifying the full path identifying a group or variable in an HDF5 file.

### **attname**

Text string specifying the name of an attribute in an HDF5 file. If the attribute does not exist, `h5writeatt` creates the attribute with the name specified.

If the specified attribute already exists but does not have a datatype or dataspace consistent with `attvalue`, `h5writeatt` deletes the attribute and recreates it. String attributes are created with a scalar dataspace.

### **attvalue**

Value to be written to the attribute in an HDF5 file.

## Examples

Create a root group attribute whose value is the current time.

```
srcFile = fullfile(matlabroot,'toolbox','matlab','demos','example.h5');
copyfile(srcFile,'myfile.h5');
fileattrib('myfile.h5','+w');
h5writeatt('myfile.h5','/', 'creation_date',datestr(now));
```

Create a double-precision data set attribute.

```
srcFile = fullfile(matlabroot,'toolbox','matlab','demos','example.h5');
copyfile(srcFile,'myfile.h5');
fileattrib('myfile.h5','+w');
attData = [0 1 2 3];
h5writeatt('myfile.h5','/g4/world','attr',attData);
h5disp('myfile.h5','/g4/world');
```

## See Also

[h5readatt](#) | [h5disp](#) | [h5write](#)

## Tutorials

- “Exporting to HDF5 Files”

# H5.close

---

|                    |                                                  |
|--------------------|--------------------------------------------------|
| <b>Purpose</b>     | Close HDF5 library                               |
| <b>Syntax</b>      | <code>H5.close()</code>                          |
| <b>Description</b> | <code>H5.close()</code> closes the HDF5 library. |
| <b>See Also</b>    | <code>H5.open</code>                             |



**Purpose** Free unused memory in HDF5 library

**Syntax** H5.garbage\_collect()

**Description** H5.garbage\_collect() frees unused memory in the HDF5 library.

# H5.get\_libversion

---

**Purpose** Version of HDF5 library

**Syntax** [majnum,minnum,relnum] = H5.get\_libversion()

**Description** [majnum,minnum,relnum] = H5.get\_libversion() returns the version of the HDF5 library in use.

|                    |                                                |
|--------------------|------------------------------------------------|
| <b>Purpose</b>     | Open HDF5 library                              |
| <b>Syntax</b>      | <code>H5.open()</code>                         |
| <b>Description</b> | <code>H5.open()</code> opens the HDF5 library. |
| <b>See Also</b>    | <code>H5.close</code>                          |

## H5.set\_free\_list\_limits

---

|                    |                                                                                                                                                                         |
|--------------------|-------------------------------------------------------------------------------------------------------------------------------------------------------------------------|
| <b>Purpose</b>     | Set size limits on free lists                                                                                                                                           |
| <b>Syntax</b>      | <code>H5.set_free_list_limits(reg_global_lim,reg_list_lim,arr_global_lim, arr_list_lim,blk_global_lim,blk_list_lim)</code>                                              |
| <b>Description</b> | <code>H5.set_free_list_limits(reg_global_lim,reg_list_lim,arr_global_lim, arr_list_lim,blk_global_lim,blk_list_lim)</code> sets size limits on all types of free lists. |

|                    |                                                                                                                                  |
|--------------------|----------------------------------------------------------------------------------------------------------------------------------|
| <b>Purpose</b>     | Close specified attribute                                                                                                        |
| <b>Syntax</b>      | <code>H5A.close(attr_id)</code>                                                                                                  |
| <b>Description</b> | <code>H5A.close(attr_id)</code> terminates access to the attribute specified by <code>attr_id</code> , releasing the identifier. |
| <b>See Also</b>    | <code>H5A.open</code>                                                                                                            |

# H5A.create

---

## Purpose

Create attribute

## Syntax

```
attr_id = H5A.create(loc_id,name,type_id,space_id,acpl_id)
attr_id = H5A.create(loc_id,name,type_id,space_id,acpl_id,aapl_id)
```

## Description

`attr_id = H5A.create(loc_id,name,type_id,space_id,acpl_id)` creates the attribute name that is attached to the object specified by `loc_id`. `loc_id` is a group, dataset, or named datatype identifier. The datatype and dataspace identifiers of the attribute, `type_id` and `space_id`, respectively, are created with the `H5T` and `H5S` interfaces. The attribute property list, `acpl_id`, is currently unused and should be set to `'H5P_DEFAULT'`. This interface corresponds to the 1.6.x version of `H5Acreate`.

`attr_id = H5A.create(loc_id,name,type_id,space_id,acpl_id,aapl_id)` creates the attribute with the additional attribute access property list identifier `aapl_id`. `aapl_id` should currently be set to `'H5P_DEFAULT'`. This interface corresponds to the 1.8.x version of `H5Acreate`.

## Examples

```
acpl_id = H5P.create('H5P_ATTRIBUTE_CREATE');
type_id = H5T.copy('H5T_NATIVE_DOUBLE');
space_id = H5S.create('H5S_SCALAR');
fid = H5F.create('myfile.h5');
attr_id = H5A.create(fid,'my_attr',type_id,space_id,acpl_id);
H5A.close(attr_id);
H5F.close(fid);
```

## See Also

`H5A.close` | `H5P.create`

**Purpose** Delete attribute

**Syntax** H5A.delete(loc\_id,name)

**Description** H5A.delete(loc\_id,name) removes the attribute specified by name from the dataset, group, or named datatype specified by loc\_id.

**Examples** Delete a root group attribute.

```
srcFile = fullfile(matlabroot,'toolbox','matlab','demos','example.h5');
copyfile(srcFile,'myfile.h5');
fileattrib('myfile.h5','+w');
fid = H5F.open('myfile.h5','H5F_ACC_RDWR','H5P_DEFAULT');
gid = H5G.open(fid,'/');
H5A.delete(gid,'attr1');
H5G.close(gid);
H5F.close(fid);
```

# H5A.get\_info

---

|                    |                                                                                                                                                                                        |
|--------------------|----------------------------------------------------------------------------------------------------------------------------------------------------------------------------------------|
| <b>Purpose</b>     | Information about attribute                                                                                                                                                            |
| <b>Syntax</b>      | <code>info = H5A.get_info(attr_id)</code>                                                                                                                                              |
| <b>Description</b> | <code>info = H5A.get_info(attr_id)</code> returns information about an attribute specified by <code>attr_id</code> .                                                                   |
| <b>Examples</b>    | <pre>fid = H5F.open('example.h5'); gid = H5G.open(fid, '/'); attr_id = H5A.open(gid, 'attr1'); info = H5A.get_info(attr_id); H5A.close(attr_id); H5G.close(gid); H5F.close(fid);</pre> |
| <b>See Also</b>    | <code>H5A.open</code>                                                                                                                                                                  |



**Purpose** Attribute name

**Syntax** `attr_name = H5A.get_name(attr_id)`

**Description** `attr_name = H5A.get_name(attr_id)` returns the name of the attribute specified by `attr_id`.

**Examples**

```
fid = H5F.open('example.h5');
gid = H5G.open(fid, '/g1/g1.1');
idx_type = 'H5_INDEX_NAME';
order = 'H5_ITER_INC';
attr_id = H5A.open_by_idx(gid, 'dset1.1.1', idx_type, order, 0);
name = H5A.get_name(attr_id);
H5A.close(attr_id);
H5G.close(gid);
H5F.close(fid);
```

**See Also** `H5A.open_by_idx`

# H5A.get\_space

---

**Purpose** Copy of attribute data space

**Syntax** `dspace_id = H5A.get_space(attr_id)`

**Description** `dspace_id = H5A.get_space(attr_id)` returns a copy of the data space for the attribute specified by `attr_id`.

**Examples** Retrieve the dimensions of an attribute data space.

```
fid = H5F.open('example.h5');
attr_id = H5A.open(fid, 'attr2');
space = H5A.get_space(attr_id);
[~, dims] = H5S.get_simple_extent_dims(space);
H5A.close(attr_id);
H5F.close(fid);
```

**See Also** [H5A.open](#) | [H5S.close](#)

**Purpose** Copy of attribute data type

**Syntax** `type_id = H5A.get_type(attr_id)`

**Description** `type_id = H5A.get_type(attr_id)` returns a copy of the data type for the attribute specified by `attr_id`.

**Examples**

```
fid = H5F.open('example.h5');
gid = H5G.open(fid, '/');
attr_id = H5A.open(gid, 'attr1');
type_id = H5A.get_type(attr_id);
H5T.close(type_id);
H5A.close(attr_id);
H5G.close(gid);
H5F.close(fid);
```

**See Also** `H5A.open` | `H5T.close`

# H5A.iterate

---

**Purpose** Execute function for attributes attached to object

**Syntax**

```
[status,idx_stop,cdata_out] = H5A.iterate(obj_id,idx_type,order,
 idx_start,iter_func,cdata_in)
H5A.iterate(loc_id,attr_idx,iterator_func)
```

**Description**

```
[status,idx_stop,cdata_out] =
H5A.iterate(obj_id,idx_type,order,
idx_start,iter_func,cdata_in)
```

 executes the specified function `iter_func` for each attribute connected to an object. `obj_id` identifies the object to which attributes are attached. `idx_type` is the type of index and valid values include the following.

'H5\_INDEX\_NAME' An alpha-numeric index by attribute name

'H5\_INDEX\_CRT\_ORDER' An index by creation order

`order` specifies the index traversal order. Valid values include the following.

'H5\_ITER\_INC' Iteration from beginning to end

'H5\_ITER\_DEC' Iteration from end to beginning

'H5\_ITER\_NATIVE' Iteration in the fastest available order

`idx_start` specifies the starting point of the iteration. `idx_stop` returns the point at which iteration was stopped. This allows an interrupted iteration to be resumed.

The callback function, `iter_func`, must have the following signature:

```
[status,cdata_out] =
iter_func(obj_id,attr_name,info,cdata_in)
```

`cdata_in` is a user-defined value or structure and is passed to the first step of the iteration in the `iter_func cdata_in` parameter. The `cdata_out` of an iteration step forms the `cdata_in` for the next iteration

step. Then, the final `cdata_out` at the end of the iteration is returned to the caller as `cdata_out`. This form of `H5A.iterate` corresponds to the `H5Aiterate2` function in the HDF5 C API.

status value returned by `iter_func` is interpreted as follows.

|          |                                                                                                            |
|----------|------------------------------------------------------------------------------------------------------------|
| zero     | Continues with the iteration or returns zero status value to the caller if all members have been processed |
| positive | Stops the iteration and returns the positive status value to the caller                                    |
| negative | Stops the iteration and throws an error indicating failure                                                 |

`H5A.iterate(loc_id, attr_idx, iterator_func)` executes the specified function for each attribute of the group, dataset, or named datatype specified by `loc_id`. The `attr_idx` argument specifies where the iteration begins. `iterator_func` must be a function handle.

The iterator function must have the following signature:

```
status = iterator_func(loc_id, attr_name)
```

`loc_id` still specifies the group, dataset, or named data type passed into `H5A.iterate`, and `attr_name` specifies the current attribute. This form of `H5A.iterate` corresponds to `H5Aiterate1` function in the HDF5 C API.

# H5A.open

---

**Purpose** Open attribute

**Syntax**  
`attr_id = H5A.open(obj_id, attr_name)`  
`attr_id = H5A.open(obj_id, attr_name, aapl_id)`

**Description**  
`attr_id = H5A.open(obj_id, attr_name)` opens an attribute for an object specified by a parent object identifier and attribute name.  
`attr_id = H5A.open(obj_id, attr_name, aapl_id)` opens an attribute with an attribute access property list identifier, `aapl_id`. The only currently valid value for `aapl_id` is 'H5P\_DEFAULT'.

**Examples**

```
fid = H5F.open('example.h5');
gid = H5G.open(fid, '/');
attr_id = H5A.open(gid, 'attr1');
H5A.close(attr_id);
H5G.close(gid);
H5F.close(fid);
```

**See Also** [H5A.close](#) | [H5A.open\\_by\\_name](#) | [H5A.open\\_by\\_idx](#)

## Purpose

Open attribute specified by index

## Syntax

```
attr_id = H5A.open_by_idx(loc_id,obj_name,idx_type,order,n)
attr_id = H5A.open_by_idx(loc_id,obj_name,idx_type,order,n,aapl_id,
 lapl_id)
```

## Description

`attr_id = H5A.open_by_idx(loc_id,obj_name,idx_type,order,n)` opens an existing attribute at index `n` attached to an object specified by its location, `loc_id`, and name, `obj_name`.

`idx_type` is the type of index and valid values include the following.

|                      |                                          |
|----------------------|------------------------------------------|
| 'H5_INDEX_NAME'      | An alpha-numeric index by attribute name |
| 'H5_INDEX_CRT_ORDER' | An index by creation order               |

`order` specifies the index traversal order. Valid values include the following.

|                  |                                          |
|------------------|------------------------------------------|
| 'H5_ITER_INC'    | Iteration from beginning to end          |
| 'H5_ITER_DEC'    | Iteration from end to beginning          |
| 'H5_ITER_NATIVE' | Iteration in the fastest available order |

`attr_id = H5A.open_by_idx(loc_id,obj_name,idx_type,order,n,aapl_id,lapl_id)` opens an attribute with attribute access property list, `aapl_id`, and link access property list, `lapl_id`. The `aapl_id` argument must currently be specified as 'H5P\_DEFAULT'. Also, `lapl_id` can be specified by 'H5P\_DEFAULT'.

## Examples

Loop through a set of dataset attributes in reverse alphabetical order.

```
fid = H5F.open('example.h5');
gid = H5G.open(fid,'/g1/g1.1');
dset_id = H5D.open(fid,'/g1/g1.1/dset1.1.1');
```

## H5A.open\_by\_idx

---

```
info = H5O.get_info(dset_id);
for idx = 0:info.num_attrs-1
 attr_id =H5A.open_by_idx(gid,'dset1.1.1','H5_INDEX_NAME','H5_ITER_DEC',
 fprintf('attribute name: %s\n',H5A.get_name(attr_id));
 H5A.close(attr_id);
end
H5G.close(gid);
H5F.close(fid);
```

### See Also

[H5A.open](#) | [H5A.open\\_by\\_name](#) | [H5A.close](#)



**Purpose**

Open attribute specified by name

**Syntax**

```
attr_id = H5A.open_by_name(loc_id,obj_name,attr_name)
attr_id = H5A.open_by_name(loc_id,obj_name,attr_name,aapl_id,lapl_id)
```

**Description**

`attr_id = H5A.open_by_name(loc_id,obj_name,attr_name)` opens an existing attribute `attr_name` attached to an object specified by its location `loc_id` and name `obj_name`.

```
attr_id =
H5A.open_by_name(loc_id,obj_name,attr_name,aapl_id,lapl_id)
```

opens an existing attribute with the attribute access property list `aapl_id` and link access property list `lacpl_id`. `aapl_id` must be specified as 'H5P\_DEFAULT'. `lapl_id` may also be specified by 'H5P\_DEFAULT'.

**Examples**

```
fid = H5F.open('example.h5');
gid = H5G.open(fid,'/g1/g1.1');
attr_id = H5A.open_by_name(gid,'dset1.1.1','attr1');
H5A.close(attr_id);
H5G.close(gid);
H5F.close(fid);
```

**See Also**

[H5A.close](#) | [H5A.open](#) | [H5A.open\\_by\\_idx](#)

# H5A.read

---

**Purpose** Read attribute

**Syntax**  
`attr = H5A.read(attr_id)`  
`attr = H5A.read(attr_id, mem_type_id)`

**Description** `attr = H5A.read(attr_id)` reads the attribute specified by `attr_id`. MATLAB will determine the appropriate memory datatype.

`attr = H5A.read(attr_id, mem_type_id)` reads the attribute specified by `attr_id`. `mem_type_id` specifies the attribute's memory datatype and should usually be given as `'H5ML_DEFAULT'`, which specifies that MATLAB will determine the appropriate memory datatype.

---

**Note** The HDF5 library uses C-style ordering for multidimensional arrays, while MATLAB uses FORTRAN-style ordering. If the HDF5 library reports the attribute size as 3-by-4-by-5, then the corresponding MATLAB array size is 5-by-4-by-3. Please consult "Using the MATLAB Low-Level HDF5 Functions" in the MATLAB documentation for more information.

---

**Examples**

```
fid = H5F.open('example.h5');
gid = H5G.open(fid, '/');
attr_id = H5A.open(gid, 'attr1');
data = H5A.read(attr_id);
H5A.close(attr_id);
H5G.close(gid);
H5F.close(fid);
```

**See Also** [H5A.open](#) | [H5A.write](#)

**Purpose** Write attribute

**Syntax** `H5A.write(attr_id,type_id,buf)`

**Description** `H5A.write(attr_id,type_id,buf)` writes the data in `buf` into the attribute specified by `attr_id`. `type_id` specifies the attribute's memory datatype. The memory datatype should be `'H5ML_DEFAULT'`, which specifies that MATLAB should determine the appropriate memory datatype.

---

**Note** The HDF5 library uses C-style ordering for multidimensional arrays, while MATLAB uses FORTRAN-style ordering. If the MATLAB array size is 5-by-4-by-3, then the HDF5 library should be reporting the attribute size as 3-by-4-by-5. Please consult "Using the MATLAB Low-Level HDF5 Functions" in the MATLAB documentation for more information.

---

**Examples** Write a scalar double precision attribute.

```
acpl = H5P.create('H5P_ATTRIBUTE_CREATE');
type_id = H5T.copy('H5T_NATIVE_DOUBLE');
space_id = H5S.create('H5S_SCALAR');
fid = H5F.create('myfile.h5');
attr_id = H5A.create(fid,'my_attr',type_id,space_id,acpl);
H5A.write(attr_id,'H5ML_DEFAULT',10.0)
H5A.close(attr_id);
H5F.close(fid);
H5T.close(type_id);
```

**See Also** `H5A.read`

# H5D.close

---

|                    |                                                                                                                                     |
|--------------------|-------------------------------------------------------------------------------------------------------------------------------------|
| <b>Purpose</b>     | Close dataset                                                                                                                       |
| <b>Syntax</b>      | <code>H5D.close(dataset_id)</code>                                                                                                  |
| <b>Description</b> | <code>H5D.close(dataset_id)</code> ends access to a dataset specified by <code>dataset_id</code> and releases resources used by it. |
| <b>See Also</b>    | <code>H5D.create</code>   <code>H5D.open</code>                                                                                     |

## Purpose

Create new dataset

## Syntax

```
dataset_id = H5D.create(loc_id,name,type_id,space_id,plist_id)
dataset_id = H5D.create(loc_id,name,type_id,space_id,lcpl_id,dcpl_id,
 dapl_id)
```

## Description

`dataset_id = H5D.create(loc_id,name,type_id,space_id,plist_id)` creates the data set specified by name in the file or in the group specified by `loc_id`. `type_id` and `space_id` identify the datatype and dataspace, respectively. `plist_id` identifies the dataset creation property list. This interface corresponds to the `H5Dcreate1` function in the HDF5 library C 1.6 API.

`dataset_id = H5D.create(loc_id,name,type_id,space_id,lcpl_id,dcpl_id,dapl_id)` creates the data set with three distinct property lists:

|                      |                                |
|----------------------|--------------------------------|
| <code>lcpl_id</code> | link creation property list    |
| <code>dcpl_id</code> | dataset creation property list |
| <code>dapl_id</code> | dataset access property list   |

This interface corresponds to the `H5Dcreate` function in the HDF5 library C 1.8 API.

## Examples

Create a 10x5 double precision dataset with default property list settings.

```
fid = H5F.create('myfile.h5');
type_id = H5T.copy('H5T_NATIVE_DOUBLE');
dims = [10 5];
h5_dims = flip1r(dims);
h5_maxdims = h5_dims;
space_id = H5S.create_simple(2,h5_dims,h5_maxdims);
dcpl = 'H5P_DEFAULT';
dset_id = H5D.create(fid,'DS',type_id,space_id,dcpl);
```

## H5D.create

---

```
H5S.close(space_id);
H5T.close(type_id);
H5D.close(dset_id);
H5F.close(fid);
h5disp('myfile.h5');
```

---

Create a 6x3 fixed length string dataset. Each string will have a length of 4 characters.

```
fid = H5F.create('myfile_strings.h5');
type_id = H5T.copy('H5T_C_S1');
H5T.set_size(type_id,4);
dims = [6 3];
h5_dims = fliplr(dims);
h5_maxdims = h5_dims;
space_id = H5S.create_simple(2,h5_dims,h5_maxdims);
dcpl = 'H5P_DEFAULT';
dset_id = H5D.create(fid, 'DS', type_id, space_id, dcpl);
H5S.close(space_id);
H5T.close(type_id);
H5D.close(dset_id);
H5F.close(fid);
h5disp('myfile_strings.h5');
```

### See Also

[H5D.close](#) | [H5S.create\\_simple](#) | [H5S.close](#) | [H5T.copy](#)

|                    |                                                                                                                                                                                    |
|--------------------|------------------------------------------------------------------------------------------------------------------------------------------------------------------------------------|
| <b>Purpose</b>     | Copy of dataset access property list                                                                                                                                               |
| <b>Syntax</b>      | <code>plist_id = H5D.get_access_plist(dataset_id)</code>                                                                                                                           |
| <b>Description</b> | <code>plist_id = H5D.get_access_plist(dataset_id)</code> returns a copy of the dataset access property list used to open the specified dataset.                                    |
| <b>Examples</b>    | <pre>fid = H5F.open('example.h5'); dset_id = H5D.open(fid, '/g1/g1.1/dset1.1.1'); dapl = H5D.get_access_plist(dset_id); H5P.close(dapl); H5D.close(dset_id); H5F.close(fid);</pre> |
| <b>See Also</b>    | <code>H5D.get_create_plist</code>   <code>H5P.close</code>                                                                                                                         |

# H5D.get\_create\_plist

---

**Purpose** Copy of dataset creation property list

**Syntax** `plist_id = H5D.get_create_plist(dataset_id)`

**Description** `plist_id = H5D.get_create_plist(dataset_id)` returns the identifier to a copy of the dataset creation property list for the dataset specified by `dataset_id`.

**Examples**

```
fid = H5F.open('example.h5');
dset_id = H5D.open(fid, '/g1/g1.1/dset1.1.1');
dcpl = H5D.get_create_plist(dset_id);
H5P.close(dcpl);
H5D.close(dset_id);
H5F.close(fid);
```

**See Also** `H5D.get_access_plist` | `H5P.close`



**Purpose**

Location of dataset in file

**Syntax**

```
offset = H5D.get_offset(dataset_id)
```

**Description**

`offset = H5D.get_offset(dataset_id)` returns the location in the file of the dataset specified by `dataset_id`. The location is expressed as an offset, in bytes, from the beginning of the file.

**Examples**

```
fid = H5F.open('example.h5');
dset_id = H5D.open(fid, '/g1/g1.1/dset1.1.1');
offset = H5D.get_offset(dset_id);
H5D.close(dset_id);
H5F.close(fid);
```

# H5D.get\_space

---

**Purpose** Copy of dataset data space

**Syntax** `dspace_id = H5D.get_space(dataset_id)`

**Description** `dspace_id = H5D.get_space(dataset_id)` returns an identifier for a copy of the data space for a dataset.

**Examples** Retrieve the dimensions of an attribute data space.

```
fid = H5F.open('example.h5');
dset_id = H5D.open(fid, '/g1/g1.1/dset1.1.1');
space = H5D.get_space(dset_id);
[~, dims] = H5S.get_simple_extent_dims(space);
H5S.close(space);
H5D.close(dset_id);
H5F.close(fid);
```

**See Also** `H5D.open` | `H5S.close`

**Purpose** Determine if space is allocated

**Syntax** `status = H5D.get_space_status(dataset_id)`

**Description** `status = H5D.get_space_status(dataset_id)` determines whether space has been allocated for the dataset specified by `dataset_id`.

**Examples**

```
fid = H5F.open('example.h5');
dset_id = H5D.open(fid, '/g1/g1.1/dset1.1.1');
status = H5D.get_space_status(dset_id);
switch(status)
 case H5ML.get_constant_value('H5D_SPACE_STATUS_NOT_ALLOCATED')
 fprintf('Not allocated.\n');
 case H5ML.get_constant_value('H5D_SPACE_STATUS_ALLOCATED')
 fprintf('Allocated.\n');
 case H5ML.get_constant_value('H5D_SPACE_STATUS_PART_ALLOCATED')
 fprintf('Part allocated.\n');
end
H5D.close(dset_id);
H5F.close(fid);
```

**See Also** `H5D.get_space`

# H5D.get\_storage\_size

---

**Purpose** Determine required storage size

**Syntax** `dataset_size = H5D.get_storage_size(dataset_id)`

**Description** `dataset_size = H5D.get_storage_size(dataset_id)` returns the amount of storage that is required for the dataset specified by `dataset_id`.

**Examples**

```
fid = H5F.open('example.h5');
dset_id = H5D.open(fid, '/g1/g1.1/dset1.1.1');
dataset_size = H5D.get_storage_size(dset_id);
H5D.close(dset_id);
H5F.close(fid);
```

|                    |                                                                                                                                                                                  |
|--------------------|----------------------------------------------------------------------------------------------------------------------------------------------------------------------------------|
| <b>Purpose</b>     | Copy of datatype                                                                                                                                                                 |
| <b>Syntax</b>      | <code>type_id = H5D.get_type(dataset_id)</code>                                                                                                                                  |
| <b>Description</b> | <code>type_id = H5D.get_type(dataset_id)</code> returns an identifier for a copy of the data type for the dataset specified by <code>dataset_id</code> .                         |
| <b>Examples</b>    | <pre>fid = H5F.open('example.h5'); dset_id = H5D.open(fid, '/g1/g1.1/dset1.1.1'); type_id = H5D.get_type(dset_id); H5T.close(type_id); H5D.close(dset_id); H5F.close(fid);</pre> |
| <b>See Also</b>    | <code>H5T.close</code>                                                                                                                                                           |

# H5D.open

---

**Purpose** Open specified dataset

**Syntax**  
`dataset_id = H5D.open(loc_id,name)`  
`dataset_id = H5D.open(loc_id,name,dapl_id)`

**Description** `dataset_id = H5D.open(loc_id,name)` opens the dataset specified by name in the file or group specified by `loc_id`.

`dataset_id = H5D.open(loc_id,name,dapl_id)` opens the dataset specified by name in the file or group specified by `loc_id`. The dataset access property list, `dapl_id`, provides information regarding access to the dataset.

**Examples**

```
fid = H5F.open('example.h5');
gid = H5G.open(fid,'/g2');
dset_id = H5D.open(gid,'dset2.2');
H5D.close(dset_id);
H5F.close(fid);
```

**See Also** `H5D.close`

**Purpose** Read data from HDF5 dataset

**Syntax**

```
data = H5D.read(dataset_id)
data = H5D.read(dataset_id,mem_type_id,mem_space_id,file_space_id,
 dxpl)
```

**Description** `data = H5D.read(dataset_id)` reads the entire dataset specified by `dataset_id`.

`data = H5D.read(dataset_id,mem_type_id,mem_space_id,file_space_id,dxpl)` reads the dataset specified by `dataset_id`. The `mem_type_id` input specifies the memory data type and should usually be 'H5ML\_DEFAULT' to allow MATLAB to determine the appropriate value. `mem_space_id` describes how the data is to be arranged in memory and should usually be 'H5S\_ALL'. The `file_space_id` input describes how the data is to be selected from the file. It also can be given as 'H5S\_ALL', but this results in the entire dataset being read into memory. `dxpl` is the dataset transfer property list identifier and should usually be 'H5P\_DEFAULT'.

---

**Note** The HDF5 library uses C-style ordering for multidimensional arrays, while MATLAB uses FORTRAN-style ordering. Please consult "Using the MATLAB Low-Level HDF5 Functions" in the MATLAB documentation for more information.

---

**Examples** Read an entire dataset.

```
fid = H5F.open('example.h5');
dset_id = H5D.open(fid, '/g1/g1.1/dset1.1.1');
data = H5D.read(dset_id);
H5D.close(dset_id);
H5F.close(fid);
```

---

# H5D.read

---

Read the 2x3 hyperslab starting in the 4th row and 5th column of the example dataset.

```
plist = 'H5P_DEFAULT';
fid = H5F.open('example.h5');
dset_id = H5D.open(fid, '/g1/g1.1/dset1.1.1');
dims = fliplr([2 3]);
mem_space_id = H5S.create_simple(2,dims,[]);
file_space_id = H5D.get_space(dset_id);
offset = fliplr([3 4]);
block = fliplr([2 3]);
H5S.select_hyperslab(file_space_id, 'H5S_SELECT_SET', offset, [], [], block);
data = H5D.read(dset_id, 'H5ML_DEFAULT', mem_space_id, file_space_id, plist);
H5D.close(dset_id);
H5F.close(fid);
```

## See Also

[H5D.open](#) | [H5D.write](#) | [H5S.create\\_simple](#)



|                    |                                                                                                                                                                |
|--------------------|----------------------------------------------------------------------------------------------------------------------------------------------------------------|
| <b>Purpose</b>     | Change size of dataset dimensions                                                                                                                              |
| <b>Syntax</b>      | <code>H5D.set_extent(dset_id,h5_extents)</code>                                                                                                                |
| <b>Description</b> | <code>H5D.set_extent(dset_id,h5_extents)</code> changes the dimensions of the dataset <code>dset_id</code> to the sizes specified in <code>h5_extents</code> . |

---

**Note** The HDF5 library uses C-style ordering for multidimensional arrays, while MATLAB uses FORTRAN-style ordering. The `h5_extents` parameter assumes C-style ordering. Please consult "Using the MATLAB Low-Level HDF5 Functions" in the MATLAB documentation for more information.

---

**Examples** Extend an unlimited one-dimensional dataset from a length of 10 to a length of 20.

```
srcFile = fullfile(matlabroot,'toolbox','matlab','demos','example.h5');
copyfile(srcFile,'myfile.h5');
fileattrib('myfile.h5','+w');
fid = H5F.open('myfile.h5','H5F_ACC_RDWR','H5P_DEFAULT');
dset_id = H5D.open(fid,'/g4/time');
H5D.set_extent(dset_id,20);
H5D.close(dset_id);
H5F.close(fid);
```

# H5D.vlen\_get\_buf\_size

---

**Purpose** Determine variable length storage requirements

**Syntax** `size = H5D.vlen_get_buf_size(dataset_id,type_id,space_id)`

**Description** `size = H5D.vlen_get_buf_size(dataset_id,type_id,space_id)` determines the number of bytes required to store the VL data from the dataset, using the `space_id` for the selection in the dataset on disk and the `type_id` for the memory representation of the VL data in memory.

**Purpose**

Write data to HDF5 dataset

**Syntax**

```
H5D.write(dataset_id,mem_type_id,mem_space_id,file_space_id,plist_id,
buf)
```

**Description**

H5D.write(dataset\_id,mem\_type\_id,mem\_space\_id,file\_space\_id,plist\_id, buf) writes the dataset specified by dataset\_id from the application memory buffer buf into the file. plist\_id specifies the data transfer properties. mem\_type\_id identifies the memory datatype of the dataset. mem\_space\_id and file\_space\_id define the part of the dataset to write. The memory datatype should usually be 'H5ML\_DEFAULT', which specifies that MATLAB should determine the appropriate memory datatype.

---

**Note** The HDF5 library uses C-style ordering for multidimensional arrays, while MATLAB uses FORTRAN-style ordering. Please consult "Using the MATLAB Low-Level HDF5 Functions" in the MATLAB documentation for more information.

---

**Examples**

Write to the entire 36-by-19 /g4/world example dataset.

```
srcFile = fullfile(matlabroot,'toolbox','matlab','demos','example.h5');
copyfile(srcFile,'myfile.h5');
fileattrib('myfile.h5','+w');
plist = 'H5P_DEFAULT';
fid = H5F.open('myfile.h5','H5F_ACC_RDWR',plist);
dset_id = H5D.open(fid,'/g4/world');
dims = [36 19];
data = rand(dims);
H5D.write(dset_id,'H5ML_DEFAULT','H5S_ALL','H5S_ALL',plist,data);
H5D.close(dset_id);
H5F.close(fid);
```

---

## H5D.write

---

Write to the entire two-element /g3/VLstring dataset.

```
srcFile = fullfile(matlabroot,'toolbox','matlab','demos','example.h5');
copyfile(srcFile,'myfile.h5');
fileattrib('myfile.h5','+w');
h5disp('myfile.h5','/g3/VLstring');
plist = 'H5P_DEFAULT';
fid = H5F.open('myfile.h5','H5F_ACC_RDWR',plist);
dset_id = H5D.open(fid,'/g3/VLstring');
data = {'dogs'; 'dogs and cats'};
H5D.write(dset_id,'H5ML_DEFAULT','H5S_ALL','H5S_ALL',plist,data);
H5D.close(dset_id);
H5F.close(fid);
data_out = h5read('myfile.h5','/g3/VLstring');
```

---

Write a 10-by-5 block of data to the location starting at row index 15 and column index 5 of the same dataset. Recall that indexing is zero-based.

```
srcFile = fullfile(matlabroot,'toolbox','matlab','demos','example.h5');
copyfile(srcFile,'myfile.h5');
fileattrib('myfile.h5','+w');
plist = 'H5P_DEFAULT';
fid = H5F.open('myfile.h5','H5F_ACC_RDWR',plist);
dset_id = H5D.open(fid,'/g4/world');
start = [15 5];
h5_start = fliplr(start);
block = [10 5];
h5_block = fliplr(block);
mem_space_id = H5S.create_simple(2,h5_block,[]);
file_space_id = H5D.get_space(dset_id);
H5S.select_hyperslab(file_space_id,'H5S_SELECT_SET',h5_start,[],[],h5_block);
data = rand(block);
H5D.write(dset_id,'H5ML_DEFAULT',mem_space_id,file_space_id,plist,data);
H5D.close(dset_id);
H5F.close(fid);
```

## See Also

H5D.read

# H5DS.attach\_scale

---

|                    |                                                                                                                                  |
|--------------------|----------------------------------------------------------------------------------------------------------------------------------|
| <b>Purpose</b>     | Attach dimension scale to specific dataset dimension                                                                             |
| <b>Syntax</b>      | H5DS.attach_scale(dataset_id,dimscale_id,idx)                                                                                    |
| <b>Description</b> | H5DS.attach_scale(dataset_id,dimscale_id,idx) attaches a dimension scale dimscale_id to dimension idx of the dataset dataset_id. |

---

**Note** The ordering of the dimension scale indices are the same as the HDF5 library C API.

---

**Examples** Add the 'lon' and 'lat' dimension scales to the 'world' dataset.

```
plist = 'H5P_DEFAULT';
srcFile = fullfile(matlabroot,'toolbox','matlab','demos','example.h5');
copyfile(srcFile,'myfile.h5');
fileattrib('myfile.h5','+w');
fid = H5F.open('myfile.h5','H5F_ACC_RDWR',plist);
world_dset_id = H5D.open(fid,'/g4/world',plist);
lat_dset_id = H5D.open(fid,'/g4/lat',plist);
lon_dset_id = H5D.open(fid,'/g4/lon',plist);
H5DS.attach_scale(world_dset_id,lat_dset_id,0);
H5DS.attach_scale(world_dset_id,lon_dset_id,1);
H5D.close(lat_dset_id);
H5D.close(lon_dset_id);
H5D.close(world_dset_id);
H5F.close(fid);
```

**See Also** H5DS.detach\_scale

**Purpose** Detach dimension scale from specific dataset dimension

**Syntax** `H5DS.detach_scale(dataset_id,dimscale_id,idx)`

**Description** `H5DS.detach_scale(dataset_id,dimscale_id,idx)` detaches dimension scale `dimscale_id` from dimension `idx` of the dataset `dataset_id`.

---

**Note** The ordering of the dimension scale indices are the same as the HDF5 library C API.

---

**See Also** `H5DS.attach_scale`

# H5DS.get\_label

---

**Purpose** Retrieve label from specific dataset dimension

**Syntax** `label = H5DS.get_label(dataset_id,idx)`

**Description** `label = H5DS.get_label(dataset_id,idx)` retrieves the label for dimension `idx` of the dataset `dataset_id`.

---

**Note** The ordering of the dimension scale indices are the same as the HDF5 library C API.

---

**Examples**

```
fid = H5F.open('example.h5');
world_dset_id = H5D.open(fid, '/g4/world');
label = H5DS.get_label(world_dset_id,0);
H5D.close(world_dset_id);
H5F.close(fid);
```

**See Also** `H5DS.set_label`



**Purpose** Number of scales attached to dataset dimension

**Syntax** `num_scales = H5DS.get_num_scales(dataset_id,idx)`

**Description** `num_scales = H5DS.get_num_scales(dataset_id,idx)` determines the number of dimension scales that are attached to dimension `idx` of the dataset `dataset_id`.

**Examples**

```
fid = H5F.open('example.h5');
world_dset_id = H5D.open(fid,'/g4/world');
num_scales = H5DS.get_num_scales(world_dset_id,0);
H5D.close(world_dset_id);
H5F.close(fid);
```

# H5DS.get\_scale\_name

---

**Purpose** Name of dimension scale

**Syntax** `name = H5DS.get_scale_name(dimscale_id)`

**Description** `name = H5DS.get_scale_name(dimscale_id)` retrieves the name of the dimension scale `dimscale_id`.

**Examples**

```
fid = H5F.open('example.h5');
lat_dset_id = H5D.open(fid, '/g4/lat');
scale_name = H5DS.get_scale_name(lat_dset_id);
H5D.close(lat_dset_id);
H5F.close(fid);
```

**See Also** `H5DS.set_scale`

**Purpose** Determine if dataset is a dimension scale

**Syntax** `bool = H5DS.is_scale(dataset_id)`

**Description** `bool = H5DS.is_scale(dataset_id)` determines whether the dataset `dataset_id` is a dimension scale.

**Examples**

```
fid = H5F.open('example.h5');
lat_dset_id = H5D.open(fid, '/g4/lat');
if H5DS.is_scale(lat_dset_id)
 fprintf('/g4/lat is a dimension scale.\n');
else
 fprintf('/g4/lat is not a dimension scale.\n');
end
H5D.close(lat_dset_id);
H5F.close(fid);
```

# H5DS.iterate\_scales

---

**Purpose** Iterate on scales attached to dataset dimension

**Syntax** `[status,idx_out,opdata_out] = H5DS.iterate_scales(dset_id,dim,idx_in, iter_func,opdata_in)`

**Description** `[status,idx_out,opdata_out] = H5DS.iterate_scales(dset_id,dim,idx_in, iter_func,opdata_in)` iterates over the scales attached to dimension `dim` of the dataset `dset_id` to perform a common operation whose function handle is `iter_func`.

`idx_in` specifies the starting point of the iteration. `idx_out` returns the point at which iteration was stopped. This allows an interrupted iteration to be resumed. If `idx_in` is `[]`, then the iterator starts at the first member.

The callback function `iter_func` must have the following signature:

```
function [status,opdata_out] =
iter_func(dset_id,dim,dimscale_id,opdata_in)
```

`opdata_in` is a user-defined value or structure and is passed to the first step of the iteration in the `iter_func` `opdata_in` parameter. The `opdata_out` of an iteration step forms the `opdata_in` for the next iteration step. The final `opdata_out` at the end of the iteration is then returned to the caller as `opdata_out`.

`dimscale_id` specifies the current dimension scale dataset identifier and `dim` is the associated dimension.

`status` value returned by `iter_func` is interpreted as follows:

|          |                                                                                                            |
|----------|------------------------------------------------------------------------------------------------------------|
| zero     | Continues with the iteration or returns zero status value to the caller if all members have been processed |
| positive | Stops the iteration and returns the positive status value to the caller                                    |
| negative | Stops the iteration and throws an error indicating failure                                                 |

# H5DS.set\_label

---

**Purpose** Set label for dataset dimension

**Syntax** H5DS.set\_label(dataset\_id,idx,label)

**Description** H5DS.set\_label(dataset\_id,idx,label) sets a label for dimension idx of the dataset dataset\_id.

---

**Note** The ordering of the dimension scale indices are the same as the HDF5 library C API.

---

## Examples

```
plist = 'H5P_DEFAULT';
srcFile = fullfile(matlabroot,'toolbox','matlab','demos','example.h5');
copyfile(srcFile,'myfile.h5');
fileattrib('myfile.h5','+w');
fid = H5F.open('myfile.h5','H5F_ACC_RDWR',plist);
world_dset_id = H5D.open(fid,'/g4/world',plist);
H5DS.set_label(world_dset_id,0,'latitude');
H5DS.set_label(world_dset_id,1,'longitude');
H5D.close(world_dset_id);
H5F.close(fid);
```

**See Also** H5DS.get\_label

|                    |                                                                                                                                                                                                                                                                                                                                                               |
|--------------------|---------------------------------------------------------------------------------------------------------------------------------------------------------------------------------------------------------------------------------------------------------------------------------------------------------------------------------------------------------------|
| <b>Purpose</b>     | Convert dataset to dimension scale                                                                                                                                                                                                                                                                                                                            |
| <b>Syntax</b>      | <code>H5DS.set_scale(dataset_id,dim_name)</code>                                                                                                                                                                                                                                                                                                              |
| <b>Description</b> | <code>H5DS.set_scale(dataset_id,dim_name)</code> converts the dataset, <code>dataset_id</code> , to a dimension scale with name <code>dim_name</code> .                                                                                                                                                                                                       |
| <b>Examples</b>    | <p>Create a dimension scale with name 'xdim'. The dataset has the name, 'x'.</p> <pre>fid = H5F.create('myfile.h5'); space_id = H5S.create_simple(1,10,10); dtype = 'H5T_NATIVE_INT'; dcpl = 'H5P_DEFAULT'; dset_id = H5D.create(fid,'x',dtype,space_id,dcpl); H5DS.set_scale(dset_id,'xdim'); H5S.close(space_id); H5D.close(dset_id); H5F.close(fid);</pre> |
| <b>See Also</b>    | <code>H5DS.get_scale_name</code>                                                                                                                                                                                                                                                                                                                              |

# H5E.clear

---

**Purpose** Clear error stack

**Syntax** `H5E.clear()`

**Description** `H5E.clear()` clears the error stack for the current thread.



|                    |                                                                                                                                                                                                                                      |
|--------------------|--------------------------------------------------------------------------------------------------------------------------------------------------------------------------------------------------------------------------------------|
| <b>Purpose</b>     | Description of major error number                                                                                                                                                                                                    |
| <b>Syntax</b>      | <code>err_string = H5E.get_major(major_number)</code>                                                                                                                                                                                |
| <b>Description</b> | <code>err_string = H5E.get_major(major_number)</code> returns a character string describing an error specified by the major error number, <code>major_number</code> .<br><br>The HDF5 group has deprecated the use of this function. |
| <b>See Also</b>    | <code>H5E.get_minor</code>                                                                                                                                                                                                           |

# H5E.get\_minor

---

**Purpose** Description of minor error number

**Syntax** `err_string = H5E.get_minor(minor_number)`

**Description** `err_string = H5E.get_minor(minor_number)` returns a character string describing an error specified by the minor error number, `minor_number`.

The HDF5 group has deprecated the use of this function.

**See Also** `H5E.get_major`

**Purpose** Walk error stack

**Syntax** `H5E.walk(direction,func)`

**Description** `H5E.walk(direction,func)` walks the error stack for the current thread and calls the specified function for each error along the way. `func` is a function handle. `direction` specifies how the error stack is traversed and can be given by one of the following strings or the numeric equivalent.

`'H5E_WALK_UPWARD'`

`'H5E_WALK_DOWNWARD'`

The specified function must have the following signature:

`status = func(n,error_struct)`

where `n` is the indexed position of the error in the stack and `error_struct` is a structure with the following fields:

|                        |                                      |
|------------------------|--------------------------------------|
| <code>maj_num</code>   | Major error number                   |
| <code>min_num</code>   | Minor error number                   |
| <code>func_name</code> | Function in which the error occurred |
| <code>file_name</code> | File in which the error occurred     |
| <code>line</code>      | Line in file where error occurs      |
| <code>desc</code>      | Optional supplied description        |

This function corresponds to the `H5Ewalk1` function in the HDF5 library C API.

**See Also** `H5ML.get_constant_value`

# H5F.close

---

**Purpose** Close HDF5 file

**Syntax** `H5F.close(file_id)`

**Description** `H5F.close(file_id)` terminates access to HDF5 file identified by `file_id`, flushing all data to storage.

**See Also** `H5F.open`

**Purpose** Create HDF5 file

**Syntax**

```
file_id = H5F.create(filename)
file_id = H5F.create(name, flags, fcpl_id, fapl_id)
```

**Description**

`file_id = H5F.create(filename)` creates the file specified by `filename` with default library properties if the file does not already exist.

`file_id = H5F.create(name, flags, fcpl_id, fapl_id)` creates the file specified by `name`. `flags` specifies whether to truncate the file, if it already exists, or to fail if the file already exists. `flags` can be specified by one of the following strings or the numeric equivalent:

|                 |                                              |
|-----------------|----------------------------------------------|
| 'H5F_ACC_TRUNC' | overwrite any existing file by the same name |
|-----------------|----------------------------------------------|

|                |                                   |
|----------------|-----------------------------------|
| 'H5F_ACC_EXCL' | do not overwrite an existing file |
|----------------|-----------------------------------|

`fcpl_id` is the file creation property list identifier. `fapl_id` is the file access property list identifier. A value of 'H5P\_DEFAULT' for either property list indicates that the library should use default values for the appropriate property list.

**Examples** Create an HDF5 file called 'myfile.h5'.

```
fid = H5F.create('myfile.h5');
H5F.close(fid);
```

---

Create an HDF5 file called 'myfile.h5', overwriting any existing file by the same name. Default file access and file creation properties shall apply.

```
fcpl = H5P.create('H5P_FILE_CREATE');
fapl = H5P.create('H5P_FILE_ACCESS');
fid = H5F.create('myfile.h5', 'H5F_ACC_TRUNC', fcpl, fapl);
H5F.close(fid);
```

# H5F.create

---

## See Also

[H5F.close](#) | [H5P.create](#) | [H5ML.get\\_constant\\_value](#)

**Purpose** Flush buffers to disk

**Syntax** `H5F.flush(object_id,scope)`

**Description** `H5F.flush(object_id,scope)` causes all buffers associated with a file to be immediately flushed to disk without removing the data from the cache. `object_id` can be any object associated with the file, including the file itself, a dataset, a group, an attribute, or a named data type. `scope` specifies whether the scope of the flushing action is global or local. `scope` may be one of the following strings:

`'H5F_SCOPE_GLOBAL'`

`'H5F_SCOPE_LOCAL'`

# H5F.get\_access\_plist

---

**Purpose** File access property list

**Syntax** `fapl_id = H5F.get_access_plist(file_id)`

**Description** `fapl_id = H5F.get_access_plist(file_id)` returns the file access property list identifier of the file specified by `file_id`.

**Examples**

```
fid = H5F.open('example.h5');
fapl = H5F.get_access_plist(fid);
H5P.close(fapl);
H5F.close(fid);
```

**See Also** `H5F.get_create_plist`



|                    |                                                                                                                                                                                                       |
|--------------------|-------------------------------------------------------------------------------------------------------------------------------------------------------------------------------------------------------|
| <b>Purpose</b>     | File creation property list                                                                                                                                                                           |
| <b>Syntax</b>      | <code>fcpl_id = H5F.get_create_plist(file_id)</code>                                                                                                                                                  |
| <b>Description</b> | <code>fcpl_id = H5F.get_create_plist(file_id)</code> returns a file creation property list identifier identifying the creation properties used to create the file specified by <code>file_id</code> . |
| <b>Examples</b>    | <pre>fid = H5F.open('example.h5'); fcpl = H5F.get_create_plist(fid); H5P.close(fcpl); H5F.close(fid);</pre>                                                                                           |
| <b>See Also</b>    | <code>H5F.get_access_plist</code>                                                                                                                                                                     |

# H5F.get\_filesize

---

**Purpose**            Size of HDF5 file

**Syntax**            `size = H5F.get_filesize(file_id)`

**Description**        `size = H5F.get_filesize(file_id)` returns the size of the HDF5 file specified by `file_id`.

**Purpose** Amount of free space in file

**Syntax** `free_space = H5F.get_freespace(file_id)`

**Description** `free_space = H5F.get_freespace(file_id)` returns the amount of space that is unused by any objects in the file specified by `file_id`.

# H5F.get\_info

---

**Purpose** Global information about file

**Syntax** `file_info = H5F.get_info(obj_id)`

**Description** `file_info = H5F.get_info(obj_id)` returns global information for the file associated with the object identifier `obj_id`. For details about the fields of the `file_info` structure, please refer to the HDF5 documentation.

**Examples**

```
fid = H5F.open('example.h5');
gid = H5G.open(fid, 'g2');
info = H5F.get_info(gid);
H5G.close(gid);
H5F.close(fid);
```

|                    |                                                                                                                                |
|--------------------|--------------------------------------------------------------------------------------------------------------------------------|
| <b>Purpose</b>     | Metadata cache configuration                                                                                                   |
| <b>Syntax</b>      | <code>config_struct = H5F.get_mdc_config(file_id)</code>                                                                       |
| <b>Description</b> | <code>config_struct = H5F.get_mdc_config(file_id)</code> returns the current metadata cache configuration for the target file. |
| <b>Examples</b>    | <pre>fid = H5F.open('example.h5'); config = H5F.get_mdc_config(fid); H5F.close(fid);</pre>                                     |
| <b>See Also</b>    | <code>H5F.set_mdc_config</code>                                                                                                |

# H5F.get\_mdc\_hit\_rate

---

**Purpose** Metadata cache hit-rate

**Syntax** `hitRate = H5F.get_mdc_hit_rate(file_id)`

**Description** `hitRate = H5F.get_mdc_hit_rate(file_id)` queries the metadata cache of the target file to obtain its hit-rate since the last time hit-rate statistics were reset. If the cache has not been accessed since the last time the hit-rate statistics were reset, the hit-rate is defined to be 0.0. The hit-rate is calculated as

$$(\text{cache hits} / (\text{cache hits} + \text{cache misses}))$$

**Examples**

```
fid = H5F.open('example.h5');
hit_rate = H5F.get_mdc_hit_rate(fid);
H5F.close(fid);
```

**See Also** `H5F.get_mdc_config`

|                    |                                                                                                                                                                                         |
|--------------------|-----------------------------------------------------------------------------------------------------------------------------------------------------------------------------------------|
| <b>Purpose</b>     | Metadata cache size data                                                                                                                                                                |
| <b>Syntax</b>      | <pre>[max_sz,min_clean_sz,cursz,<br/> num_cur_entries] = H5F.get_mdc_size(fileId)</pre>                                                                                                 |
| <b>Description</b> | <pre>[max_sz,min_clean_sz,cursz, num_cur_entries] =<br/>H5F.get_mdc_size(fileId)</pre> queries the metadata cache of the target file to obtain current metadata cache size information. |
| <b>Examples</b>    | <pre>fid = H5F.open('example.h5');<br/>[maxsz,minsz,cursz,nent] = H5F.get_mdc_size(fid);<br/>H5F.close(fid);</pre>                                                                      |
| <b>See Also</b>    | H5F.get_mdc_config                                                                                                                                                                      |

# H5F.get\_name

---

**Purpose** Name of HDF5 file

**Syntax** `name = H5F.get_name(obj_id)`

**Description** `name = H5F.get_name(obj_id)` returns the name of the file to which the object `obj_id` belongs. The object can be a group, dataset, attribute, or named data type.

**Examples**

```
fid = H5F.open('example.h5');
name = H5F.get_name(fid);
H5F.close(fid);
```

**See Also** [H5A.get\\_name](#) | [H5I.get\\_name](#)



**Purpose**

Number of open objects in HDF5 file

**Syntax**

```
obj_count = H5F.get_obj_count(file_id,types)
```

**Description**

`obj_count = H5F.get_obj_count(file_id,types)` returns the number of open object identifiers for the file specified by `file_id` for the specified type. `types` can be one of the following strings.

```
'H5F_OBJ_FILE'
'H5F_OBJ_DATASET'
'H5F_OBJ_GROUP'
'H5F_OBJ_DATATYPE'
'H5F_OBJ_ATTR'
'H5F_OBJ_ALL'
'H5F_OBJ_LOCAL'
```

**Examples**

```
fid = H5F.open('example.h5');
gid = H5G.open(fid, '/g2');
obj_count = H5F.get_obj_count(fid, 'H5F_OBJ_GROUP');
H5G.close(gid);
H5F.close(fid);
```

**See Also**

`H5F.get_obj_ids`

# H5F.get\_obj\_ids

---

|                    |                                                                                                                                                                                                                                                                                                                                                                                                                                                                                                                                                                                                                                                                                        |
|--------------------|----------------------------------------------------------------------------------------------------------------------------------------------------------------------------------------------------------------------------------------------------------------------------------------------------------------------------------------------------------------------------------------------------------------------------------------------------------------------------------------------------------------------------------------------------------------------------------------------------------------------------------------------------------------------------------------|
| <b>Purpose</b>     | List of open HDF5 file objects                                                                                                                                                                                                                                                                                                                                                                                                                                                                                                                                                                                                                                                         |
| <b>Syntax</b>      | <code>[num_obj_ids,obj_id_list] = H5F.get_obj_ids(file_id,types,max_objs)</code>                                                                                                                                                                                                                                                                                                                                                                                                                                                                                                                                                                                                       |
| <b>Description</b> | <p><code>[num_obj_ids,obj_id_list] = H5F.get_obj_ids(file_id,types,max_objs)</code> returns a list of all open identifiers for HDF5 objects of the type specified by <code>types</code> in the file specified by <code>file_id</code>. The <code>max_objs</code> input specifies the maximum number of object identifiers to return. <code>num_obj_ids</code> is the total number of objects in the list. <code>types</code> can be one of the following strings.</p> <ul style="list-style-type: none"><li>'H5F_OBJ_FILE'</li><li>'H5F_OBJ_DATASET'</li><li>'H5F_OBJ_GROUP'</li><li>'H5F_OBJ_DATATYPE'</li><li>'H5F_OBJ_ATTR'</li><li>'H5F_OBJ_ALL'</li><li>'H5F_OBJ_LOCAL'</li></ul> |
| <b>Examples</b>    | <pre>fid = H5F.open('example.h5'); gid1 = H5G.open(fid,'/g1'); gid2 = H5G.open(fid,'/g2'); gid3 = H5G.open(fid,'/g3'); gid4 = H5G.open(fid,'/g4'); [num_obj_ids,objs] = H5F.get_obj_ids(fid,'H5F_OBJ_GROUP',3); H5G.close(gid1); H5G.close(gid2); H5G.close(gid3); H5G.close(gid4); H5F.close(fid);</pre>                                                                                                                                                                                                                                                                                                                                                                              |
| <b>See Also</b>    | <code>H5F.get_obj_count</code>                                                                                                                                                                                                                                                                                                                                                                                                                                                                                                                                                                                                                                                         |

**Purpose** Determine if file is HDF5

**Syntax** `value = H5F.is_hdf5(name)`

**Description** `value = H5F.is_hdf5(name)` returns a positive number if the file specified by name is in the HDF5 format, and zero if it is not. A negative return value indicates failure.

**Examples**

```
value = H5F.is_hdf5('example.tif');
if value > 0
 fprintf('example.tif is an HDF5 file\n');
else
 fprintf('example.tif is not an HDF5 file\n');
end
```

# H5F.mount

---

**Purpose** Mount HDF5 file onto specified location

**Syntax** `H5F.mount(loc_id,name,child_id,plist_id)`

**Description** `H5F.mount(loc_id,name,child_id,plist_id)` mounts the file specified by `child_id` onto the group specified by `loc_id` and `name`, using the mount properties specified by `plist_id`.

**Examples** Mount one file with a dataset onto a group in a second file and access the dataset via the second file.

```
plist = 'H5P_DEFAULT';
fid2 = H5F.create('file2.h5', 'H5F_ACC_TRUNC', plist, plist);
gid2 = H5G.create(fid2, 'g2', plist, plist, plist);
fid1 = H5F.create('file1.h5', 'H5F_ACC_TRUNC', 'H5P_DEFAULT', ...
 'H5P_DEFAULT');
space_id = H5S.create('H5S_SCALAR');
dset_id = H5D.create(fid1, 'DS1', 'H5T_NATIVE_DOUBLE', space_id, plist);
H5S.close(space_id);
H5D.close(dset_id);
H5F.mount(fid2, 'g2', fid1, plist);
dset_id1 = H5D.open(fid1, '/g2/DS1', plist);
H5D.close(dset_id1);
H5F.unmount(fid1, 'g2');
H5G.close(gid2);
H5F.close(fid1);
H5F.close(fid2);
```

**See Also** `H5F.unmount`

**Purpose** Open HDF5 file

**Syntax**

```
file_id = H5F.open(filename)
file_id = H5F.open(name, flags, fapl_id)
```

**Description**

`file_id = H5F.open(filename)` opens the file specified by `filename` for read-only access and returns the file identifier, `file_id`.

`file_id = H5F.open(name, flags, fapl_id)` opens the file specified by `name`, returning the file identifier, `file_id`. `flags` specifies file access flags and can be specified by one of the following strings or their numeric equivalents:

|                  |                 |
|------------------|-----------------|
| 'H5F_ACC_RDWR'   | read-write mode |
| 'H5F_ACC_RDONLY' | read-only mode  |

The file access property list, `fapl_id`, may be specified as 'H5P\_DEFAULT', in which case the default I/O settings are used.

**Examples** Open a file in read-only mode with default file access properties.

```
fid = H5F.open('example.h5');
H5F.close(fid);
```

---

Open a file in read-write mode.

```
srcFile = fullfile(matlabroot, 'toolbox', 'matlab', 'demos', 'example.h5');
copyfile(srcFile, 'myfile.h5');
fileattrib('myfile.h5', '+w');
fid = H5F.open('myfile.h5', 'H5F_ACC_RDWR', 'H5P_DEFAULT');
H5F.close(fid);
```

**See Also** [H5F.close](#) | [H5ML.get\\_constant\\_value](#)

# H5F.reopen

---

**Purpose** Reopen HDF5 file

**Syntax** `new_file_id = H5F.reopen(file_id)`

**Description** `new_file_id = H5F.reopen(file_id)` returns a new file identifier for the already open HDF5 file specified by `file_id`.

**See Also** `H5F.open`

|                    |                                                                                                                                                                                                                                                                     |
|--------------------|---------------------------------------------------------------------------------------------------------------------------------------------------------------------------------------------------------------------------------------------------------------------|
| <b>Purpose</b>     | Configure HDF5 file metadata cache                                                                                                                                                                                                                                  |
| <b>Syntax</b>      | <code>H5F.set_mdc_config(fileId,config)</code>                                                                                                                                                                                                                      |
| <b>Description</b> | <code>H5F.set_mdc_config(fileId,config)</code> attempts to configure the file's metadata cache according to the supplied configuration structure. Before using this function, you should retrieve the current configuration using <code>H5F.get_mdc_config</code> . |
| <b>See Also</b>    | <code>H5F.get_mdc_config</code>                                                                                                                                                                                                                                     |

# H5F.unmount

---

|                    |                                                                                                                                                                                                                     |
|--------------------|---------------------------------------------------------------------------------------------------------------------------------------------------------------------------------------------------------------------|
| <b>Purpose</b>     | Unmount file or group from mount point                                                                                                                                                                              |
| <b>Syntax</b>      | <code>H5F.unmount(loc_id,name)</code>                                                                                                                                                                               |
| <b>Description</b> | <code>H5F.unmount(loc_id,name)</code> disassociates the file or group specified by <code>loc_id</code> from the mount point specified by <code>name</code> . <code>loc_id</code> can be a file or group identifier. |
| <b>See Also</b>    | <code>H5F.mount</code>                                                                                                                                                                                              |



**Purpose** Close group

**Syntax** `H5G.close(group_id)`

**Description** `H5G.close(group_id)` releases resources used by the group specified by `group_id`. `group_id` was returned by either `H5G.create` or `H5G.open`.

**See Also** `H5G.create` | `H5G.open`

# H5G.create

---

|                    |                                                                                                                                                                                                                                                                                                                                                                                                                                                                                                                                                                                                                                                                                                                                                        |
|--------------------|--------------------------------------------------------------------------------------------------------------------------------------------------------------------------------------------------------------------------------------------------------------------------------------------------------------------------------------------------------------------------------------------------------------------------------------------------------------------------------------------------------------------------------------------------------------------------------------------------------------------------------------------------------------------------------------------------------------------------------------------------------|
| <b>Purpose</b>     | Create group                                                                                                                                                                                                                                                                                                                                                                                                                                                                                                                                                                                                                                                                                                                                           |
| <b>Syntax</b>      | <pre>group_id = H5G.create(loc_id,name,size_hint) group_id = H5G.create(loc_id,name,lcpl_id,gcpl_id,gapl_id)</pre>                                                                                                                                                                                                                                                                                                                                                                                                                                                                                                                                                                                                                                     |
| <b>Description</b> | <p><code>group_id = H5G.create(loc_id,name,size_hint)</code> creates a new group with the name specified by <code>name</code> at the location specified by <code>loc_id</code>. <code>loc_id</code> can be a file or group identifier. <code>size_hint</code> specifies the number of bytes to reserve for the names that will appear in the group. This interface corresponds to the 1.6 version of <code>H5Gcreate</code>.</p> <p><code>group_id = H5G.create(loc_id,name,lcpl_id,gcpl_id,gapl_id)</code> creates a new group with link creation, group creation, and group access property lists <code>lcpl_id</code>, <code>gcpl_id</code>, and <code>gapl_id</code>. This interface corresponds to the 1.8 version of <code>H5Gcreate</code>.</p> |
| <b>Examples</b>    | <p>Create an HDF5 file 'myfile.h5' with a group 'my_group' with default property list settings.</p> <pre>fid = H5F.create('myfile.h5'); plist = 'H5P_DEFAULT'; gid = H5G.create(fid,'my_group',plist,plist,plist); H5G.close(gid); H5F.close(fid);</pre>                                                                                                                                                                                                                                                                                                                                                                                                                                                                                               |
| <b>See Also</b>    | <a href="#">H5G.open</a>   <a href="#">H5G.close</a>                                                                                                                                                                                                                                                                                                                                                                                                                                                                                                                                                                                                                                                                                                   |

|                    |                                                                                                                                |
|--------------------|--------------------------------------------------------------------------------------------------------------------------------|
| <b>Purpose</b>     | Information about group                                                                                                        |
| <b>Syntax</b>      | <code>info = H5G.get_info(group_id)</code>                                                                                     |
| <b>Description</b> | <code>info = H5G.get_info(group_id)</code> retrieves information about the group specified by <code>group_id</code> .          |
| <b>Examples</b>    | <pre>fid = H5F.open('example.h5'); gid = H5G.open(fid, '/g2'); info = H5G.get_info(gid); H5G.close(gid); H5F.close(fid);</pre> |
| <b>See Also</b>    | <code>H5G.open</code>   <code>H5G.create</code>                                                                                |

# H5G.open

---

**Purpose** Open specified group

**Syntax**  
`group_id = H5G.open(loc_id,name)`  
`group_id = H5G.open(loc_id,name,gapl_id)`

**Description**  
`group_id = H5G.open(loc_id,name)` opens the group specified by `name` at the location specified by `loc_id`. `loc_id` is a file or group identifier. This interface corresponds to the 1.6 version of H5Gopen.  
`group_id = H5G.open(loc_id,name,gapl_id)` opens the group with an additional group access property list, `gapl_id`. This interface corresponds to the 1.8 version of H5Gopen.

**Examples**  

```
fid = H5F.open('example.h5');
gid = H5G.open(fid,'/g2');
H5G.close(gid);
H5F.close(fid);
```

**See Also** [H5G.close](#) | [H5P.create](#)

**Purpose** Decrement reference count

**Syntax** `ref_count = H5I.dec_ref(obj_id)`

**Description** `ref_count = H5I.dec_ref(obj_id)` decrements the reference count of the object identified by `obj_id` and returns the new count.

**See Also** `H5I.get_ref` | `H5I.inc_ref`

# H5I.get\_file\_id

---

**Purpose** File identifier for specified object

**Syntax** `file_id = H5I.get_file_id(obj_id)`

**Description** `file_id = H5I.get_file_id(obj_id)` returns the identifier of the file associated with the object referenced by `obj_id`.

**Examples**

```
fid = H5F.open('example.h5');
gid = H5G.open(fid, '/g4');
fid2 = H5I.get_file_id(gid);
name = H5F.get_name(fid2);
fprintf('The filename is %s.\n', name);
H5G.close(gid);
H5F.close(fid);
H5F.close(fid2);
```

|                    |                                                                                                                                                                                                                                                                                                                                                                                                                                                                                                                       |
|--------------------|-----------------------------------------------------------------------------------------------------------------------------------------------------------------------------------------------------------------------------------------------------------------------------------------------------------------------------------------------------------------------------------------------------------------------------------------------------------------------------------------------------------------------|
| <b>Purpose</b>     | Name of object                                                                                                                                                                                                                                                                                                                                                                                                                                                                                                        |
| <b>Syntax</b>      | <code>name = H5I.get_name(obj_id)</code>                                                                                                                                                                                                                                                                                                                                                                                                                                                                              |
| <b>Description</b> | <code>name = H5I.get_name(obj_id)</code> returns the name of the object specified by <code>obj_id</code> . If no name is attached to the object, the empty string is returned.                                                                                                                                                                                                                                                                                                                                        |
| <b>Examples</b>    | <p>Display the names of all the objects in the <code>/g3</code> group in the example file by alphabetical order.</p> <pre>idx_type = 'H5_INDEX_NAME'; order = 'H5_ITER_INC'; fid = H5F.open('example.h5'); gid = H5G.open(fid, '/g3'); info = H5G.get_info(gid); for j = 1:info.nlinks     obj_id = H5O.open_by_idx(fid, 'g3', idx_type, order, j-1, 'H5P_DEFAULT');     name = H5I.get_name(obj_id);     fprintf('Object %d: '%s''.\n', j-1, name);     H5O.close(obj_id); end H5G.close(gid); H5F.close(fid);</pre> |
| <b>See Also</b>    | <code>H5A.get_name</code>   <code>H5F.get_name</code>                                                                                                                                                                                                                                                                                                                                                                                                                                                                 |

# H5I.get\_ref

---

|                    |                                                                                                                          |
|--------------------|--------------------------------------------------------------------------------------------------------------------------|
| <b>Purpose</b>     | Reference count of object                                                                                                |
| <b>Syntax</b>      | <code>refcount = H5I.get_ref(obj_id)</code>                                                                              |
| <b>Description</b> | <code>refcount = H5I.get_ref(obj_id)</code> returns the reference count of the object specified by <code>obj_id</code> . |
| <b>See Also</b>    | <code>H5I.dec_ref</code>   <code>H5I.inc_ref</code>                                                                      |



**Purpose**

Type of object

**Syntax**

```
obj_type = H5I.get_type(obj_id)
```

**Description**

`obj_type = H5I.get_type(obj_id)` returns the type of the object specified by `obj_id`. `obj_type` corresponds to one of the following enumerated values.

```
H5I_FILE
H5I_GROUP
H5I_DATATYPE
H5I_DATASPACE
H5I_DATASET
H5I_ATTR
H5I_BADID
```

**Examples**

```
fid = H5F.open('example.h5');
gid = H5G.open(fid, '/g3');
dset_id = H5D.open(fid, '/g4/world');
[~,objs] = H5F.get_obj_ids(fid, 'H5F_OBJ_ALL', 3);
for j = 1:numel(objs)
 name = H5I.get_name(objs(j));
 fprintf('object '%s': ==> ', name);
 type = H5I.get_type(objs(j));
 switch(type)
 case H5ML.get_constant_value('H5I_FILE')
 fprintf('FILE identifier.\n');
 case H5ML.get_constant_value('H5I_GROUP')
 fprintf('GROUP identifier.\n');
 case H5ML.get_constant_value('H5I_DATASET')
 fprintf('DATASET identifier.\n');
 otherwise
 fprintf('unknown identifier type.\n');
 end
end
```

# H5I.get\_type

---

```
end
H5G.close(gid);
H5F.close(fid);
```

## **See Also**

H5ML.get\_constant\_value

|                    |                                                                                                                                                       |
|--------------------|-------------------------------------------------------------------------------------------------------------------------------------------------------|
| <b>Purpose</b>     | Increment reference count of specified object                                                                                                         |
| <b>Syntax</b>      | <code>ref_count = H5I.inc_ref(obj_id)</code>                                                                                                          |
| <b>Description</b> | <code>ref_count = H5I.inc_ref(obj_id)</code> increments the reference count of the object specified by <code>obj_id</code> and returns the new count. |
| <b>See Also</b>    | <code>H5I.dec_ref</code>   <code>H5I.get_ref</code>                                                                                                   |

# H5I.is\_valid

---

**Purpose** Determine if specified identifier is valid

**Syntax** `tf = H5I.is_valid(obj_id)`

**Description** `tf = H5I.is_valid(obj_id)` determines whether the identifier `obj_id` is valid.

**Examples**

```
fap1 = H5P.create('H5P_FILE_ACCESS');
H5P.close(fap1);
if H5I.is_valid(fap1);
 fprintf('File access property list is valid.\n');
else
 fprintf('File access property list is not valid.\n');
end
```

|                    |                                                                                                                                                                                                                                                                                                                                                                                                                                                                                                                                                                                                                                                                             |
|--------------------|-----------------------------------------------------------------------------------------------------------------------------------------------------------------------------------------------------------------------------------------------------------------------------------------------------------------------------------------------------------------------------------------------------------------------------------------------------------------------------------------------------------------------------------------------------------------------------------------------------------------------------------------------------------------------------|
| <b>Purpose</b>     | Copy link from source location to destination location                                                                                                                                                                                                                                                                                                                                                                                                                                                                                                                                                                                                                      |
| <b>Syntax</b>      | <code>H5L.copy(src_loc_id,src_name,dest_loc_id,dest_name,lcpl_id,lapl_id)</code>                                                                                                                                                                                                                                                                                                                                                                                                                                                                                                                                                                                            |
| <b>Description</b> | <p><code>H5L.copy(src_loc_id,src_name,dest_loc_id,dest_name,lcpl_id,lapl_id)</code> copies the link specified by <code>src_name</code> from the file or group specified by <code>src_loc_id</code> to the destination <code>dest_loc_id</code>. The new copy of the link is created with the name <code>dest_name</code>.</p> <p><code>dest_loc_id</code> must refer to either the current file or a group in the current file. If <code>dest_loc_id</code> is the file identifier, the copy is placed in the file's root group.</p> <p>The new link is created with the creation and access property lists specified by <code>lcpl_id</code> and <code>lapl_id</code>.</p> |
| <b>Examples</b>    | <pre>plist_id = 'H5P_DEFAULT'; fid = H5F.create('myfile.h5', 'H5F_ACC_TRUNC', plist_id, plist_id); g1 = H5G.create(fid, 'g1', plist_id); g2 = H5G.create(fid, 'g2', plist_id); g11 = H5G.create(g1, 'g3', plist_id); H5L.copy(g1, 'g3', g2, 'g4', plist_id, plist_id);</pre>                                                                                                                                                                                                                                                                                                                                                                                                |

# H5L.create\_external

---

|                    |                                                                                                                                                                                                                                                                                                                                                                                                                                                                                                                                                                                                                                                                                                                                                                         |
|--------------------|-------------------------------------------------------------------------------------------------------------------------------------------------------------------------------------------------------------------------------------------------------------------------------------------------------------------------------------------------------------------------------------------------------------------------------------------------------------------------------------------------------------------------------------------------------------------------------------------------------------------------------------------------------------------------------------------------------------------------------------------------------------------------|
| <b>Purpose</b>     | Create soft link to external object                                                                                                                                                                                                                                                                                                                                                                                                                                                                                                                                                                                                                                                                                                                                     |
| <b>Syntax</b>      | <code>H5L.create_external(filename,objname,link_loc_id,link_name,lcpl_id,lapl_id)</code>                                                                                                                                                                                                                                                                                                                                                                                                                                                                                                                                                                                                                                                                                |
| <b>Description</b> | <p><code>H5L.create_external(filename,objname,link_loc_id,link_name,lcpl_id,lapl_id)</code> creates a soft link to an object in a different file. <code>filename</code> identifies the target file containing the target object. <code>obj_name</code> specifies the path to the target object within that file. <code>obj_name</code> must start at the target file's root group but is not interpreted until lookup time.</p> <p><code>link_loc_id</code> and <code>link_name</code> specify the location and name, respectively, of the new link. <code>link_name</code> is interpreted relative to <code>link_loc_id</code>.</p> <p><code>lcpl_id</code> and <code>lapl_id</code> are the link creation and access property lists associated with the new link.</p> |
| <b>Examples</b>    | <pre>plist_id = 'H5P_DEFAULT'; fid1 = H5F.create('myfile1.h5'); g1 = H5G.create(fid1,'g1',plist_id,plist_id,plist_id); H5G.close(g1); H5F.close(fid1); fid2 = H5F.create('myfile2.h5'); H5L.create_external('myfile1.h5','g1',fid2,'g2',plist_id,plist_id);</pre>                                                                                                                                                                                                                                                                                                                                                                                                                                                                                                       |

|                    |                                                                                                                                                                                                                                                                                                                                                                                                                                                                                                                                                                                                                                                                                                                                              |
|--------------------|----------------------------------------------------------------------------------------------------------------------------------------------------------------------------------------------------------------------------------------------------------------------------------------------------------------------------------------------------------------------------------------------------------------------------------------------------------------------------------------------------------------------------------------------------------------------------------------------------------------------------------------------------------------------------------------------------------------------------------------------|
| <b>Purpose</b>     | Create hard link                                                                                                                                                                                                                                                                                                                                                                                                                                                                                                                                                                                                                                                                                                                             |
| <b>Syntax</b>      | <code>H5L.create_hard(obj_loc_id,obj_name,link_loc_id,link_name,lcpl_id,lapl_id)</code>                                                                                                                                                                                                                                                                                                                                                                                                                                                                                                                                                                                                                                                      |
| <b>Description</b> | <p><code>H5L.create_hard(obj_loc_id,obj_name,link_loc_id,link_name,lcpl_id,lapl_id)</code> creates a new hard link to a pre-existing object in an HDF5 file. The new link may be one of many that point to that object. <code>obj_loc_id</code> and <code>obj_name</code> specify the location and name, respectively, of the target object, i.e., the object to which the new hard link points.</p> <p><code>link_loc_id</code> and <code>link_name</code> specify the location and name, respectively, of the new link. <code>link_name</code> is interpreted relative to <code>link_loc_id</code>.</p> <p><code>lcpl_id</code> and <code>lapl_id</code> are the link creation and access property lists associated with the new link.</p> |
| <b>Examples</b>    | <pre>fid = H5F.create('myfile.h5'); gid1 = H5G.create(fid, '/g1', 0); gid2 = H5G.create(gid1, 'g2', 0); gid3 = H5G.create(gid2, 'g3', 0); lcpl = 'H5P_DEFAULT'; lapl = 'H5P_DEFAULT'; H5L.create_hard(gid2, 'g3', gid1, 'g4', lcpl, lapl); H5G.close(gid3); H5G.close(gid2); H5G.close(gid1); H5F.close(fid);</pre>                                                                                                                                                                                                                                                                                                                                                                                                                          |
| <b>See Also</b>    | <code>H5L.create_soft</code>                                                                                                                                                                                                                                                                                                                                                                                                                                                                                                                                                                                                                                                                                                                 |

# H5L.create\_soft

---

**Purpose** Create soft link

**Syntax** `H5L.create_soft(target_path,link_loc_id,link_name,lcpl_id,lapl_id)`

**Description** `H5L.create_soft(target_path,link_loc_id,link_name,lcpl_id,lapl_id)` creates a new soft link to an object in an HDF5 file. The new link may be one of many that point to that object. `target_path` specifies the path to the target object, i.e., the object that the new soft link points to. `target_path` can be anything and is interpreted at lookup time. This `target_path` may be absolute in the file or relative to `link_loc_id`.

`link_loc_id` and `link_name` specify the location and name, respectively, of the new link. `link_name` is interpreted relative to `link_loc_id`.

`lcpl_id` and `lapl_id` are the link creation and access property lists associated with the new link.

**Examples**

```
plist_id = 'H5P_DEFAULT';
fid = H5F.create('myfile.h5');
gid1 = H5G.create(fid, '/g1', 0);
gid3 = H5G.create(gid1, 'g3', 0);
gid2 = H5G.create(fid, '/g2', 0);
lcpl = 'H5P_DEFAULT';
lapl = 'H5P_DEFAULT';
H5L.create_soft('/g1/g3', gid2, 'g4', lcpl, lapl);
H5G.close(gid3);
H5G.close(gid2);
H5G.close(gid1);
H5F.close(fid);
```

**See Also** `H5L.create_hard`



**Purpose** Remove link

**Syntax** H5L.delete(loc\_id,name,lapl\_id)

**Description** H5L.delete(loc\_id,name,lapl\_id) removes the link specified by name from the location loc\_id. lapl\_id is a link access property list identifier.

**Examples** Remove the only link to the '/g3' group in example.h5.

```
srcFile = fullfile(matlabroot,'toolbox','matlab','demos','example.h5');
copyfile(srcFile,'myfile.h5');
fileattrib('myfile.h5','+w');
fid = H5F.open('myfile.h5','H5F_ACC_RDWR','H5P_DEFAULT');
H5L.delete(fid,'g3','H5P_DEFAULT');
H5F.close(fid);
```

**See Also** H5L.move

# H5L.exists

---

**Purpose** Determine if link exists

**Syntax** `bool = H5L.exists(loc_id,name,lapl_id)`

**Description** `bool = H5L.exists(loc_id,name,lapl_id)` checks if a link specified by the pairing of an object id and name exists within a group. `lapl_id` is a link access property list identifier.

**Examples**

```
fid = H5F.open('example.h5');
gid = H5G.open(fid,'/g1/g1.2/g1.2.1');
if H5L.exists(gid,'slink','H5P_DEFAULT')
 fprintf('link exists\n');
else
 fprintf('link does not exist\n');
end
```

|                    |                                                                                                                                                                                                                                                                                                                         |
|--------------------|-------------------------------------------------------------------------------------------------------------------------------------------------------------------------------------------------------------------------------------------------------------------------------------------------------------------------|
| <b>Purpose</b>     | Information about link                                                                                                                                                                                                                                                                                                  |
| <b>Syntax</b>      | <code>linkStruct = H5L.get_info(location_id,link_name,lapl_id)</code>                                                                                                                                                                                                                                                   |
| <b>Description</b> | <p><code>linkStruct = H5L.get_info(location_id,link_name,lapl_id)</code> returns information about a link.</p> <p>A file or group identifier, <code>location_id</code>, specifies the location of the link. <code>link_name</code>, interpreted relative to <code>link_id</code>, specifies the link being queried.</p> |
| <b>Examples</b>    | <pre>fid = H5F.open('example.h5'); info = H5L.get_info(fid,'g3','H5P_DEFAULT'); H5F.close(fid);</pre>                                                                                                                                                                                                                   |

# H5L.get\_name\_by\_idx

---

**Purpose** Information about link specified by index

**Syntax** `name = H5L.get_name_by_idx(loc_id,group_name,idx_type,order,n,lapl_id)`

**Description** `name = H5L.get_name_by_idx(loc_id,group_name,idx_type,order,n,lapl_id)` retrieves information about a link at index `n`, present in group `group_name`, at location `loc_id`. The `lapl_id` input specifies the link access property list for querying the group.

`idx_type` is the type of index and valid values include the following.

|                      |                             |
|----------------------|-----------------------------|
| 'H5_INDEX_NAME'      | Alpha-numeric index on name |
| 'H5_INDEX_CRT_ORDER' | Index on creation order     |

`order` specifies the index traversal order. Valid values include the following.

|                  |                                          |
|------------------|------------------------------------------|
| 'H5_ITER_INC'    | Iteration from beginning to end          |
| 'H5_ITER_DEC'    | Iteration from end to beginning          |
| 'H5_ITER_NATIVE' | Iteration in the fastest available order |

**Examples**

```
fid = H5F.open('example.h5');
idx_type = 'H5_INDEX_NAME';
order = 'H5_ITER_DEC';
lapl_id = 'H5P_DEFAULT';
name = H5L.get_name_by_idx(fid,'g3',idx_type,order,0,lapl_id);
H5F.close(fid);
```

|                    |                                                                                                                                                                                                                                                                                                                                                                                                                                                                                                                                                                                                                                                                                                                                                                        |
|--------------------|------------------------------------------------------------------------------------------------------------------------------------------------------------------------------------------------------------------------------------------------------------------------------------------------------------------------------------------------------------------------------------------------------------------------------------------------------------------------------------------------------------------------------------------------------------------------------------------------------------------------------------------------------------------------------------------------------------------------------------------------------------------------|
| <b>Purpose</b>     | Value of symbolic link                                                                                                                                                                                                                                                                                                                                                                                                                                                                                                                                                                                                                                                                                                                                                 |
| <b>Syntax</b>      | <code>linkval = H5L.get_val(link_loc_id,link_name,lapl_id)</code>                                                                                                                                                                                                                                                                                                                                                                                                                                                                                                                                                                                                                                                                                                      |
| <b>Description</b> | <p><code>linkval = H5L.get_val(link_loc_id,link_name,lapl_id)</code> returns the value of a symbolic link.</p> <p><code>link_loc_id</code> is a file or group identifier. <code>link_name</code> identifies a symbolic link and is defined relative to <code>link_loc_id</code>. Symbolic links include soft and external links and some user-defined links.</p> <p>In the case of soft links, <code>linkval</code> is a cell array containing the path to which the link points.</p> <p>In the case of external links, <code>linkval</code> is a cell array consisting of the name of the target file and the object name.</p> <p>This function corresponds to the <code>H5L.get_val</code> and <code>H5Lunpack_elink_val</code> functions in the HDF5 1.8 C API.</p> |
| <b>Examples</b>    | <pre>fid = H5F.open('example.h5'); gid = H5G.open(fid, '/g1/g1.2/g1.2.1'); linkval = H5L.get_val(gid, 'slink', 'H5P_DEFAULT'); H5G.close(gid); H5F.close(fid);</pre>                                                                                                                                                                                                                                                                                                                                                                                                                                                                                                                                                                                                   |

# H5L.iterate

---

## Purpose

Iterate over links

## Syntax

```
[status,idx_out,opdata_out] = H5L.iterate(group_id,index_type,order,
 idx_in,iter_func,opdata_in)
```

## Description

```
[status,idx_out,opdata_out] =
H5L.iterate(group_id,index_type,order,
idx_in,iter_func,opdata_in) iterates through the links in a group,
specified by group_id, to perform a common function whose function
handle is iter_func. H5L.iterate does not recursively follow links
into subgroups of the specified group.
```

`index_type` and `order` establish the iteration. `index_type` specifies the index to be used. If the links have not been indexed by the index type, they will first be sorted by that index then the iteration will begin. If the links have been so indexed, the sorting step will be unnecessary, so the iteration may begin more quickly. Valid values include the following:

|                      |                             |
|----------------------|-----------------------------|
| 'H5_INDEX_NAME'      | Alpha-numeric index on name |
| 'H5_INDEX_CRT_ORDER' | Index on creation order     |

`order` specifies the order in which objects are to be inspected along the index specified in `index_type`. Valid values include the following:

|                  |                         |
|------------------|-------------------------|
| 'H5_ITER_INC'    | Increasing order        |
| 'H5_ITER_DEC'    | Decreasing order        |
| 'H5_ITER_NATIVE' | Fastest available order |

`idx_in` specifies the starting point of the iteration. `idx_out` returns the point at which iteration was stopped. This allows an interrupted iteration to be resumed.

The callback function `iter_func` must have the following signature:

```
function [status,opdata_out] =
iter_func(group_id,name,opdata_in)
```

`opdata_in` is a user-defined value or structure and is passed to the first step of the iteration in the `iter_func` `opdata_in` parameter. The `opdata_out` of an iteration step forms the `opdata_in` for the next iteration step. The final `opdata_out` at the end of the iteration is then returned to the caller as `opdata_out`.

status value returned by `iter_func` is interpreted as follows:

|          |                                                                                                            |
|----------|------------------------------------------------------------------------------------------------------------|
| zero     | Continues with the iteration or returns zero status value to the caller if all members have been processed |
| positive | Stops the iteration and returns the positive status value to the caller                                    |
| negative | Stops the iteration and throws an error indicating failure                                                 |

# H5L.iterate\_by\_name

---

**Purpose** Iterate through links in group specified by name

**Syntax** `[status,idx_out,opdata_out] = H5L.iterate_by_name(loc_id,group_name,  
index_type,order,idx_in,iter_func,opdata_in,lapl_id)`

**Description** `[status,idx_out,opdata_out] = H5L.iterate_by_name(loc_id,group_name,  
index_type,order,idx_in,iter_func,opdata_in,lapl_id)` iterates through the links in a group to perform a common function whose function handle is `iter_func`. The starting point of the iteration is pairing of a specified by the location id and a relative group name. `H5L.iterate_by_name` does not recursively follow links into subgroups of the specified group. A link access property list, `lapl_id`, may affect the outcome depending upon the type of link being traversed.

`index_type` and `order` establish the iteration. `index_type` specifies the index to be used. If the links have not been indexed by the index type, they will first be sorted by that index then the iteration will begin. If the links have been so indexed, the sorting step will be unnecessary, so the iteration may begin more quickly. Valid values include the following:

|                                   |                             |
|-----------------------------------|-----------------------------|
| <code>'H5_INDEX_NAME'</code>      | Alpha-numeric index on name |
| <code>'H5_INDEX_CRT_ORDER'</code> | Index on creation order     |

`order` specifies the order in which objects are to be inspected along the index specified in `index_type`. Valid values include the following:

|                               |                         |
|-------------------------------|-------------------------|
| <code>'H5_ITER_INC'</code>    | Increasing order        |
| <code>'H5_ITER_DEC'</code>    | Decreasing order        |
| <code>'H5_ITER_NATIVE'</code> | Fastest available order |

`idx_in` specifies the starting point of the iteration. `idx_out` returns the point at which iteration was stopped. This allows an interrupted iteration to be resumed.

The callback function `iter_func` must have the following signature:



```
function [status,opdata_out] =
iter_func(group_id,name,opdata_in)
```

opdata\_in is a user-defined value or structure and is passed to the first step of the iteration in the iter\_func opdata\_in parameter. The opdata\_out of an iteration step forms the opdata\_in for the next iteration step. The final opdata\_out at the end of the iteration is then returned to the caller as opdata\_out.

status value returned by iter\_func is interpreted as follows:

|          |                                                                                                            |
|----------|------------------------------------------------------------------------------------------------------------|
| zero     | Continues with the iteration or returns zero status value to the caller if all members have been processed |
| positive | Stops the iteration and returns the positive status value to the caller                                    |
| negative | Stops the iteration and throws an error indicating failure                                                 |

# H5L.move

---

**Purpose** Rename link

**Syntax** `H5L.move(src_loc_id,src_name,dest_loc_id,dest_name,lcpl_id,lapl_id)`

**Description** `H5L.move(src_loc_id,src_name,dest_loc_id,dest_name,lcpl_id,lapl_id)` renames a link within an HDF5 file. The original link, `src_name`, is removed from the group graph and the new link, `dest_name`, is inserted; this change is accomplished as an atomic operation.

`src_loc_id` and `src_name` identify the existing link. `src_loc_id` is either a file or group identifier; `src_name` is the path to the link and is interpreted relative to `src_loc_id`.

`dest_loc_id` and `dest_name` identify the new link. `dest_loc_id` is either a file or group identifier; `dest_name` is the path to the link and is interpreted relative to `dest_loc_id`.

`lcpl_id` and `lapl_id` are the link creation and link access property lists, respectively, associated with the new link, `dest_name`.

**Examples** Rename the `'/g2'` group to `'/g2/g3'`.

```
srcFile = fullfile(matlabroot,'toolbox','matlab','demos','example.h5');
copyfile(srcFile,'myfile.h5');
fileattrib('myfile.h5','+w');
fid = H5F.open('myfile.h5','H5F_ACC_RDWR','H5P_DEFAULT');
g2id = H5G.open(fid,'g2');
H5L.move(fid,'g3',g2id,'g3','H5P_DEFAULT','H5P_DEFAULT');
H5G.close(g2id);
H5F.close(fid);
```

**See Also** `H5L.delete`

**Purpose** Recursively iterate through links in group specified by group identifier

**Syntax** `[status opdata_out] = H5L.visit(group_id,index_type,order,iter_func, opdata_in)`

**Description** `[status opdata_out] = H5L.visit(group_id,index_type,order,iter_func, opdata_in)` recursively iterates through all links in and below a group, specified by `group_id`, to perform a common function whose function handle is `iter_func`.

`index_type` and `order` establish the iteration. `index_type` specifies the index to be used. If the links have not been indexed by the index type, they are first sorted by that index, and then the iteration will begin. If the links have been so indexed, the sorting step is unnecessary, so the iteration can begin more quickly. Valid values include the following.

|                                   |                             |
|-----------------------------------|-----------------------------|
| <code>'H5_INDEX_NAME'</code>      | Alpha-numeric index on name |
| <code>'H5_INDEX_CRT_ORDER'</code> | Index on creation order     |

Note that the index type passed in `index_type` is a best effort setting. If the application passes in a value indicating iteration in creation order and a group is encountered that was not tracked in creation order, that group will be iterated over in alpha-numeric order by name, or name order. (Name order is the native order used by the HDF5 Library and is always available.)

`order` specifies the order in which objects are to be inspected along the index specified in `index_type`. Valid values include the following.

|                               |                         |
|-------------------------------|-------------------------|
| <code>'H5_ITER_INC'</code>    | Increasing order        |
| <code>'H5_ITER_DEC'</code>    | Decreasing order        |
| <code>'H5_ITER_NATIVE'</code> | Fastest available order |

The callback function `iter_func` must have the following signature:

# H5L.visit

---

```
function [status,opdata_out] =
iter_func(group_id,name,opdata_in)
```

opdata\_in is a user-defined value or structure and is passed to the first step of the iteration in the iter\_func opdata\_in parameter. The opdata\_out of an iteration step forms the opdata\_in for the next iteration step. The final opdata\_out at the end of the iteration is then returned to the caller as opdata\_out.

status value returned by iter\_func is interpreted as follows.

|          |                                                                                                            |
|----------|------------------------------------------------------------------------------------------------------------|
| zero     | Continues with the iteration or returns zero status value to the caller if all members have been processed |
| positive | Stops the iteration and returns the positive status value to the caller                                    |
| negative | Stops the iteration and throws an error indicating failure                                                 |

## Purpose

Recursively iterate through links in group specified by location and group name

## Syntax

```
[status,opdata_out] = H5L.visit_by_name(loc_id,group_name,index_type,
order,iter_func,opdata_in,lapl_id)
```

## Description

```
[status,opdata_out] =
H5L.visit_by_name(loc_id,group_name,index_type,
order,iter_func,opdata_in,lapl_id)
```

recursively iterates though all links in and below a group to perform a common function whose function handle is `iter_func`. The starting point of the iteration is specified by the pairing of a location id and a relative group name. A link access property list, `lapl_id`, may affect the outcome depending upon the type of link being traversed.

`index_type` and `order` establish the iteration. `index_type` specifies the index to be used. If the links have not been indexed by the index type, they are first sorted by that index, and then the iteration will begin. If the links have been so indexed, the sorting step is unnecessary, so the iteration can begin more quickly. Valid values include the following.

|                      |                             |
|----------------------|-----------------------------|
| 'H5_INDEX_NAME'      | Alpha-numeric index on name |
| 'H5_INDEX_CRT_ORDER' | Index on creation order     |

Note that the index type passed in `index_type` is a best effort setting. If the application passes in a value indicating iteration by creation order and a group is encountered that was not tracked in creation order, that group will be iterated over in alpha-numeric order by name, or name order. (Name order is the native order used by the HDF5 Library and is always available.)

`order` specifies the order in which objects are to be inspected along the index specified in `index_type`. Valid values include the following.

## H5L.visit\_by\_name

---

|                  |                         |
|------------------|-------------------------|
| 'H5_ITER_INC'    | Increasing order        |
| 'H5_ITER_DEC'    | Decreasing order        |
| 'H5_ITER_NATIVE' | Fastest available order |

The callback function `iter_func` must have the following signature:

```
function [status,opdata_out] =
iter_func(group_id,name,opdata_in)
```

`opdata_in` is a user-defined value or structure and is passed to the first step of the iteration in the `iter_func` `opdata_in` parameter. The `opdata_out` of an iteration step forms the `opdata_in` for the next iteration step. The final `opdata_out` at the end of the iteration is then returned to the caller as `opdata_out`.

`status` value returned by `iter_func` is interpreted as follows.

|          |                                                                                                            |
|----------|------------------------------------------------------------------------------------------------------------|
| zero     | Continues with the iteration or returns zero status value to the caller if all members have been processed |
| positive | Stops the iteration and returns the positive status value to the caller                                    |
| negative | Stops the iteration and throws an error indicating failure                                                 |

**Purpose** Numerically compare two HDF5 values

**Syntax** `bEqual = H5ML.compare_values(value1,value2)`

**Description** `bEqual = H5ML.compare_values(value1,value2)` compares two values, where either or both values may be represented as a string. The values are compared numerically.

Function parameters:

|                     |                                                             |
|---------------------|-------------------------------------------------------------|
| <code>bEqual</code> | A logical value indicating whether the two values are equal |
| <code>value1</code> | The first value to be compared                              |
| <code>value2</code> | The second value to be compared                             |

**Examples**

```
val = H5ML.get_constant_value('H5T_NATIVE_INT');
H5ML.compare_values(val, 'H5T_NATIVE_INT')
```

# H5ML.get\_constant\_names

---

**Purpose** Constants known by HDF5 library

**Syntax** `names = H5ML.get_constant_names()`

**Description** `names = H5ML.get_constant_names()` returns a list of known library constants, definitions, and enumerations. When these strings are supplied as actual parameters to HDF5 functions, they are automatically be converted to the appropriate numeric value.

Function parameters.

|                    |                                     |
|--------------------|-------------------------------------|
| <code>names</code> | An alphabetized cell array of names |
|--------------------|-------------------------------------|



**Purpose** Value corresponding to a string

**Syntax** `value = H5ML.get_constant_value(constant)`

**Description** `value = H5ML.get_constant_value(constant)` returns the value corresponding to a given string. The string should correspond to an enumeration (for example, 'H5\_ENUM\_T') or a predefined identifier (for example, 'H5T\_NATIVE\_INT'). Since the value corresponding to a given string is not guaranteed to remain the same, it is almost always preferable to use the `H5ML.compare_values()` function instead.

Function parameters:

|                       |                                                                   |
|-----------------------|-------------------------------------------------------------------|
| <code>value</code>    | The value corresponding to the supplied string                    |
| <code>constant</code> | A string that corresponds to a HDF5 enumeration or defined value. |

**Examples** `a = H5ML.get_constant_value('H5T_NATIVE_INT');`

# H5ML.get\_function\_names

---

**Purpose** Functions provided by HDF5 library

**Syntax** `names = H5ML.get_function_names()`

**Description** `names = H5ML.get_function_names()` returns a list of supported library functions.

Function parameters:

|                    |                                     |
|--------------------|-------------------------------------|
| <code>names</code> | An alphabetized cell array of names |
|--------------------|-------------------------------------|

|                    |                                                                                                                                                                                                                                                                                                                                                                                                                                                                                                                          |
|--------------------|--------------------------------------------------------------------------------------------------------------------------------------------------------------------------------------------------------------------------------------------------------------------------------------------------------------------------------------------------------------------------------------------------------------------------------------------------------------------------------------------------------------------------|
| <b>Purpose</b>     | Data type for dataset ID                                                                                                                                                                                                                                                                                                                                                                                                                                                                                                 |
| <b>Syntax</b>      | <code>DTYPE_ID = H5ML.get_mem_datatype(LOCATION_ID)</code>                                                                                                                                                                                                                                                                                                                                                                                                                                                               |
| <b>Description</b> | <p><code>DTYPE_ID = H5ML.get_mem_datatype(LOCATION_ID)</code> returns the ID of an HDF5 memory datatype for the dataset or attribute identified by <code>LOCATION_ID</code>. This HDF5 memory datatype is the default used by <code>H5D.read</code> or <code>H5D.write</code> when you specify 'H5ML_DEFAULT' as a value of the memory data type parameter.</p> <p>The identifier returned by <code>H5ML.get_mem_datatype</code> should eventually be closed by calling <code>H5T.close</code> to release resources.</p> |
| <b>Examples</b>    | <pre>file_id = H5F.open('example.h5', 'H5F_ACC_RDONLY', 'H5P_DEFAULT'); dset_id = H5D.open(file_id, '/g1/g1.1/dset1.1.1'); datatype_id = H5ML.get_mem_datatype(dset_id) H5T.close(datatype_id); H5D.close(dset_id); H5F.close(file_id);</pre>                                                                                                                                                                                                                                                                            |

# H5ML.hoffset

---

**Purpose** Determine the offset of a field within a structure

---

**Note** H5ML.hoffset is not recommended. Use H5T instead.

---

## Syntax

**Description** This function is used to determine the offset (in bytes) of a structure, `H5T.insert(file_type, 'a', offset(1), dtype(1));`, within a field. It is used when constructing an HDF5 COMPOUND type. It is designed to correspond to the HDF5 HOFFSET macro. For more details about the operation of the HOFFSET macro, please consult the HDF5 documentation.

Function parameters:

|                        |                                                       |
|------------------------|-------------------------------------------------------|
| <code>offset</code>    | The byte offset of the field within the structure.    |
| <code>structure</code> | The structure which contains the specified fieldname. |
| <code>fieldname</code> | The field for which the offset is determined.         |

## Examples

This function is deprecated. It can only be used in workflows that do not include a field that is itself an HDF5 COMPOUND or of variable length. To handle these cases, the offsets should be computed directly. For example, in the case above, a file dataspace for such a compound could be created with:

```
dtype(1) = H5T.copy('H5T_NATIVE_INT');
dtype(2) = H5T.copy('H5T_NATIVE_DOUBLE');
dtype(3) = H5T.copy('H5T_NATIVE_FLOAT');

for j = 1:3, sz(j,1) = H5T.get_size(dtype(j)); end
```

```
% The first offset would always be zero and the size of the last
% field does not matter.
offset(1) = 0;
offset(2:3) = cumsum(sz(1:2));

file_type = H5T.create('H5T_COMPOUND',sum(sz));

H5T.insert(file_type,'a', offset(1), dtype(1));
H5T.insert(file_type,'b', offset(2), dtype(2));
H5T.insert(file_type,'c', offset(3), dtype(3));
```

### See Also

`H5T.get_size`

# H5ML.sizeof

---

## Purpose

Return the size (in bytes) of a variable as stored on disk

---

**Note** `H5ML.sizeof` is not recommended. Use `H5T` instead.

---

## Syntax

## Description

This function is used to determine the size (in bytes) of a structure or other (simple) variable. It is designed to correspond to the C `sizeof()` operator as it is used during the creation of HDF5 datatypes, especially the HDF5 COMPOUND type.

Function parameters:

|                   |                                                                    |
|-------------------|--------------------------------------------------------------------|
| <code>size</code> | The size (in bytes) of the variable as it would be stored on disk. |
| <code>arg</code>  | The variable for which the size is being sought.                   |

## Examples

This function is deprecated. It can only be used in workflows that do not include a field that is itself an HDF5 COMPOUND or of variable length. To handle these cases, the offsets should be computed directly. For example, in the case above, a file dataspace for such a compound could be created with:

```
dtype(1) = H5T.copy('H5T_NATIVE_INT');
dtype(2) = H5T.copy('H5T_NATIVE_DOUBLE');
dtype(3) = H5T.copy('H5T_NATIVE_FLOAT');

for j = 1:3, sz(j,1) = H5T.get_size(dtype(j)); end

% The first offset would always be zero and the size of the last
% field does not matter.
offset(1) = 0;
offset(2:3) = cumsum(sz(1:2));
```

```
file_type = H5T.create('H5T_COMPOUND', sum(sz));

H5T.insert(file_type, 'a', offset(1), dtype(1));
H5T.insert(file_type, 'b', offset(2), dtype(2));
H5T.insert(file_type, 'c', offset(3), dtype(3));
```

### See Also

H5T.get\_size

# H5O.close

---

**Purpose** Close object

**Syntax** `H5O.close(obj_id)`

**Description** `H5O.close(obj_id)` closes the object specified by `obj_id`. `obj_id` cannot be a dataspace, attribute, property list, or file.



|                    |                                                                                                                                                                                                                                                                                                                                                                                                                                                                                                                                                                                                                                                                                                                                                                                                                                                                                                                                                                                     |
|--------------------|-------------------------------------------------------------------------------------------------------------------------------------------------------------------------------------------------------------------------------------------------------------------------------------------------------------------------------------------------------------------------------------------------------------------------------------------------------------------------------------------------------------------------------------------------------------------------------------------------------------------------------------------------------------------------------------------------------------------------------------------------------------------------------------------------------------------------------------------------------------------------------------------------------------------------------------------------------------------------------------|
| <b>Purpose</b>     | Copy object from source location to destination location                                                                                                                                                                                                                                                                                                                                                                                                                                                                                                                                                                                                                                                                                                                                                                                                                                                                                                                            |
| <b>Syntax</b>      | <code>H5O.copy(src_loc_id,src_name,dst_loc_id,dst_name,ocpypl_id,lcpl_id)</code>                                                                                                                                                                                                                                                                                                                                                                                                                                                                                                                                                                                                                                                                                                                                                                                                                                                                                                    |
| <b>Description</b> | <p><code>H5O.copy(src_loc_id,src_name,dst_loc_id,dst_name,ocpypl_id,lcpl_id)</code> copies the group, dataset or named datatype specified by <code>src_name</code> from the file or group specified by <code>src_loc_id</code> to the destination location <code>dst_loc_id</code>.</p> <p>The destination location, as specified in <code>dst_loc_id</code>, may be a group in the current file or a location in a different file. If <code>dst_loc_id</code> is a file identifier, the copy will be placed in that file's root group.</p> <p>The new copy will be created with the name <code>dst_name</code>. <code>dst_name</code> must not pre-exist in the destination location. If <code>dst_name</code> already exists at the location <code>dst_loc_id</code>, the operation will fail.</p> <p>The new copy of the object is created with the object creation property and link creation property lists <code>ocpypl_id</code> and <code>lcpl_id</code>, respectively.</p> |
| <b>Examples</b>    | <p>Copy the group <code>'/g3'</code> and all its datasets to a new group <code>'/g3.5'</code>.</p> <pre>srcFile = [matlabroot '/toolbox/matlab/demos/example.h5']; copyfile(srcFile,'myfile.h5'); fileattrib('myfile.h5','+w'); ocpl = H5P.create('H5P_OBJECT_COPY'); lcpl = H5P.create('H5P_LINK_CREATE'); H5P.set_create_intermediate_group(lcpl,true); fid = H5F.open('myfile.h5','H5F_ACC_RDWR','H5P_DEFAULT'); gid = H5G.open(fid,'/'); H5O.copy(gid,'g3',gid,'g3.5',ocpl,lcpl); H5G.close(gid); H5P.close(ocpl); H5P.close(lcpl); H5F.close(fid);</pre>                                                                                                                                                                                                                                                                                                                                                                                                                       |

# H5O.get\_comment

---

**Purpose** Get comment for object specified by object identifier

**Syntax** `comment = H5O.get_comment(obj_id)`

**Description** `comment = H5O.get_comment(obj_id)` retrieves the comment for the object specified by `obj_id`.

**Examples**

```
fid = H5F.open('example.h5');
dset_id = H5D.open(fid, 'g4/world');
comment = H5O.get_comment(dset_id);
H5D.close(dset_id);
H5F.close(fid);
```

**See Also** [H5O.get\\_comment\\_by\\_name](#) | [H5O.set\\_comment](#) | [H5O.set\\_comment\\_by\\_name](#)

# H5O.get\_comment\_by\_name

---

**Purpose** Get comment for object specified by location and object name

**Syntax** `comment = H5O.get_comment_by_name(loc_id,name,lapl_id)`

**Description** `comment = H5O.get_comment_by_name(loc_id,name,lapl_id)` retrieves a comment where a location id and name together specify the object. A link access property list can affect the outcome if a link is traversed to access the object.

**Examples**

```
fid = H5F.open('example.h5','H5F_ACC_RDONLY','H5P_DEFAULT');
comment = H5O.get_comment_by_name(fid,'g4/world','H5P_DEFAULT');
H5F.close(fid);
```

**See Also** `H5O.get_comment` | `H5O.set_comment` | `H5O.set_comment_by_name`

# H5O.get\_info

---

**Purpose** Object metadata

**Syntax** `info = H5O.get_info(obj_id)`

**Description** `info = H5O.get_info(obj_id)` retrieves the metadata for an object specified by `obj_id`. For details about the object metadata, please refer to the HDF5 documentation.

**Examples** Determine the number of attributes for a dataset.

```
fid = H5F.open('example.h5', 'H5F_ACC_RDONLY', 'H5P_DEFAULT');
dsetId = H5D.open(fid, '/g1/g1.1/dset1.1.1');
info = H5O.get_info(dsetId);
info.num_attrs
```

---

Determine the type of objects in the root group.

```
plist = 'H5P_DEFAULT';
fid = H5F.open('example.h5');
gid = H5G.open(fid, '/');
root_info = H5G.get_info(gid);
idx_type = 'H5_INDEX_NAME';
order = 'H5_ITER_DEC';
for j = 0:root_info.nlinks-1
 obj_id = H5O.open_by_idx(fid, '/', idx_type, order, j, plist);
 obj_info = H5O.get_info(obj_id);
 switch(obj_info.type)
 case H5ML.get_constant_value('H5G_LINK')
 fprintf('Object #%d is a link.\n', j);
 case H5ML.get_constant_value('H5G_GROUP')
 fprintf('Object #%d is a group.\n', j);
 case H5ML.get_constant_value('H5G_DATASET')
 fprintf('Object #%d is a dataset.\n', j);
 case H5ML.get_constant_value('H5G_TYPE')
 fprintf('Object #%d is a named datatype.\n', j);
```

```
 end
 H5O.close(obj_id);
 end
 H5G.close(gid);
 H5F.close(fid);
```

### **See Also**

[H5F.open](#) | [H5G.open](#) | [H5D.open](#) | [H5T.open](#)

# H5O.link

---

**Purpose** Create hard link to specified object

**Syntax** `H5O.link(obj_id,new_loc_id,new_link_name,lcpl_id,lapl_id)`

**Description** `H5O.link(obj_id,new_loc_id,new_link_name,lcpl_id,lapl_id)` creates a hard link to an object, where `new_loc_id` and `new_link_name` specify the location. `lcpl_id` and `lapl_id` are the link creation and access property lists associated with the new link.

`H5O.link` is designed to add additional structure to an existing file so that, for example, an object can be shared among multiple groups.

**Examples** Create a hard link from group `'/g2'` to the dataset `'/g1/ds1'`.

```
plist_id = 'H5P_DEFAULT';
fid = H5F.create('myfile.h5', 'H5F_ACC_TRUNC', plist_id, plist_id);
gid1 = H5G.create(fid, '/g1', plist_id);
space_id = H5S.create_simple(1, 10, []);
ds1 = H5D.create(gid1, 'ds1', 'H5T_NATIVE_INT', space_id, plist_id);
gid2 = H5G.create(fid, '/g2', plist_id);
H5O.link(ds1, gid2, 'ds2', plist_id, plist_id);
H5D.close(ds1);
H5S.close(space_id);
H5G.close(gid2); H5G.close(gid1);
H5F.close(fid);
```

**See Also** `H5L.create_hard` | `H5L.create_soft`

**Purpose** Open specified object

**Syntax** `obj_id = H5O.open(loc_id, relname, lapl_id)`

**Description** `obj_id = H5O.open(loc_id, relname, lapl_id)` opens an object specified by location identifier and relative path name. `lapl_id` is the link access property list associated with the link pointing to the object. If default link access properties are appropriate, this can be passed in as `'H5P_DEFAULT'`.

**Examples**

```
fid = H5F.open('example.h5');
obj_id = H5O.open(fid, 'g3', 'H5P_DEFAULT');
H5O.close(obj_id);
H5F.close(fid);
```

**See Also** `H5O.open_by_idx` | `H5O.close`

# H5O.open\_by\_idx

---

**Purpose** Open object specified by index

**Syntax** `obj_id = H5O.open_by_idx(loc_id, group_name, idx_type, order, n, lapl_id)`

**Description** `obj_id = H5O.open_by_idx(loc_id, group_name, idx_type, order, n, lapl_id)` opens the n-th object in the group specified by `loc_id` and `group_name`. `loc_id` specifies a file or group. `group_name` specifies the group relative to `loc_id` in which the object can be found.

Two parameters are used to establish the iteration: `index_type` and `order`. `index_type` specifies the type of index by which objects are ordered. Valid values include the following:

|                      |                             |
|----------------------|-----------------------------|
| 'H5_INDEX_NAME'      | Alpha-numeric index on name |
| 'H5_INDEX_CRT_ORDER' | Index on creation order     |

`order` specifies the order in which the links are to be referenced for the purposes of this function. Valid values include the following:

|                  |                         |
|------------------|-------------------------|
| 'H5_ITER_INC'    | Increasing order        |
| 'H5_ITER_DEC'    | Decreasing order        |
| 'H5_ITER_NATIVE' | Fastest available order |

`n` specifies the zero-based position of the object within the index. `lapl_id` specifies the link access property list to be used in accessing the object.

**Examples**

```
fid = H5F.open('example.h5');
idx_type = 'H5_INDEX_NAME';
order = 'H5_ITER_DEC';
obj_id = H5O.open_by_idx(fid, 'g3', idx_type, order, 0, 'H5P_DEFAULT');
H5O.close(obj_id);
H5F.close(fid);
```

**See Also** [H5O.open](#) | [H5O.close](#)



|                    |                                                                                                                                                                                                                         |
|--------------------|-------------------------------------------------------------------------------------------------------------------------------------------------------------------------------------------------------------------------|
| <b>Purpose</b>     | Set comment for object specified by object identifier                                                                                                                                                                   |
| <b>Syntax</b>      | <code>H5O.set_comment(obj_id,comment)</code>                                                                                                                                                                            |
| <b>Description</b> | <code>H5O.set_comment(obj_id,comment)</code> sets a comment for the object specified by <code>obj_id</code> .                                                                                                           |
| <b>Examples</b>    | <pre>plist = 'H5P_DEFAULT'; fid = H5F.create('myfile.h5', 'H5F_ACC_TRUNC', plist, plist); gid = H5G.create(fid, '/g1', plist); H5O.set_comment(gid, 'This is a group comment. '); H5G.close(gid); H5F.close(fid);</pre> |
| <b>See Also</b>    | <code>H5O.get_comment</code>   <code>H5O.get_comment_by_name</code>  <br><code>H5O.set_comment_by_name</code>                                                                                                           |

# H5O.set\_comment\_by\_name

---

- Purpose** Set comment for object specified by location and object name
- Syntax** `H5O.set_comment_by_name(loc_id,rel_name,comment,lapl_id)`
- Description** `H5O.set_comment_by_name(loc_id,rel_name,comment,lapl_id)` sets a comment for an object specified by a location ID and a relative name. `lapl_id` is a link access property list identifier that can affect the outcome if links are traversed.
- Examples**
- ```
plist = 'H5P_DEFAULT';
fid = H5F.create('myfile.h5', 'H5F_ACC_TRUNC', plist, plist);
gid = H5G.create(fid, '/g1', plist);
H5O.set_comment_by_name(fid, 'g1', 'This is a group comment.', plist);
H5G.close(gid);
H5F.close(fid);
```
- See Also** `H5O.get_comment` | `H5O.get_comment_by_name` | `H5O.set_comment`

Purpose

Visit objects specified by object identifier

Syntax

```
[status,opdata_out] = H5O.visit(obj_id,index_type,order,iter_func,
                                opdata_in)
```

Description

[status,opdata_out] = H5O.visit(obj_id,index_type,order,iter_func, opdata_in) is a recursive iteration function to visit the object `object_id` and, if `object_id` is a group, all objects in and below it in an HDF5 file. This provides a mechanism for an application to perform a common set of operations across all of those objects or a dynamically selected subset.

If `object_id` is a group identifier, that group serves as the root of a recursive iteration. If `object_id` is a file identifier, that file's root group serves as the root of the recursive iteration. If `object_id` is any other type of object, such as a dataset or named data type, there is no iteration.

Two parameters are used to establish the iteration: `index_type` and `order`. The `index_type` parameter specifies the index used. If the links in a group have not been indexed by the index type, they are first sorted by that index, and then the iteration will begin. If the links have been so indexed, the sorting step is unnecessary, so the iteration can begin more quickly. Valid values include the following.

'H5_INDEX_NAME'	Alpha-numeric index on name
'H5_INDEX_CRT_ORDER'	Index on creation order

Note that the index type passed in `index_type` is a best effort setting. If the application passes in a value indicating iteration in creation order and a group is encountered that was not tracked in creation order, that group will be iterated over in alpha-numeric order by name, or name order. (Name order is the native order used by the HDF5 Library and is always available.) `order` specifies the order in which objects are to be inspected along the index specified in `index_type`. Valid values include the following.

H5O.visit

'H5_ITER_INC'	Increasing order
'H5_ITER_DEC'	Decreasing order
'H5_ITER_NATIVE'	Fastest available order

The callback function `iter_func` must have the following signature:

```
function [status,opdata_out] =  
iter_func(group_id,name,opdata_in)
```

`opdata_in` is a user-defined value or structure and is passed to the first step of the iteration in the `iter_func` `opdata_in` parameter. The `opdata_out` of an iteration step forms the `opdata_in` for the next iteration step. The final `opdata_out` at the end of the iteration is then returned to the caller as `opdata_out`.

`status` value returned by `iter_func` is interpreted as follows.

zero	Continues with the iteration or returns zero status value to the caller if all members have been processed
positive	Stops the iteration and returns the positive status value to the caller
negative	Stops the iteration and throws an error indicating failure

See Also

`H5O.visit_by_name`

Purpose

Visit objects specified by location and object name

Syntax

```
[status,opdata_out] = H5O.visit_by_name(loc_id,obj_name,index_type,  
order,iter_func,opdata_in,lapl_id)
```

Description

```
[status,opdata_out] =  
H5O.visit_by_name(loc_id,obj_name,index_type,  
order,iter_func,opdata_in,lapl_id) specifies the object by the  
pairing of the location identifier and object name. loc_id specifies a file  
or an object in a file and obj_name specifies an object in the file with  
either an absolute name or relative to loc_id. A link access property  
list can affect the outcome if links are involved.
```

Two parameters are used to establish the iteration: `index_type` and `order`. The `index_type` parameter specifies the index to be used. If the links in a group have not been indexed by the index type, they are first sorted by that index, and then the iteration will begin; if the links have been so indexed, the sorting step is unnecessary, so the iteration can begin more quickly. Valid values include the following.

'H5_INDEX_NAME'	Alpha-numeric index on name
'H5_INDEX_CRT_ORDER'	Index on creation order

Note that the index type passed in `index_type` is a best effort setting. If the application passes in a value indicating iteration in creation order and a group is encountered that was not tracked in creation order, that group will be iterated over in alpha-numeric order by name, or name order. (Name order is the native order used by the HDF5 Library and is always available.) `order` specifies the order in which objects are to be inspected along the index specified in `index_type`. Valid values include the following.

'H5_ITER_INC'	Increasing order
'H5_ITER_DEC'	Decreasing order
'H5_ITER_NATIVE'	Fastest available order

H5O.visit_by_name

The callback function `iter_func` must have the following signature:

```
function [status,opdata_out] =  
iter_func(group_id,name,opdata_in)
```

`opdata_in` is a user-defined value or structure and is passed to the first step of the iteration in the `iter_func` `opdata_in` parameter. The `opdata_out` of an iteration step forms the `opdata_in` for the next iteration step. The final `opdata_out` at the end of the iteration is then returned to the caller as `opdata_out`.

`lapl_id` is a link access property list. When default link access properties are acceptable, 'H5P_DEFAULT' can be used.

`status` value returned by `iter_func` is interpreted as follows.

zero	Continues with the iteration or returns zero status value to the caller if all members have been processed
positive	Stops the iteration and returns the positive status value to the caller
negative	Stops the iteration and throws an error indicating failure

See Also

H5O.visit

Purpose Close property list

Syntax `H5P.close(plist_id)`

Description `H5P.close(plist_id)` terminates access to the property list specified by `plist_id`.

See Also `H5P.create`

H5P.copy

Purpose Copy of property list

Syntax `plist_copy = H5P.copy(plist_id)`

Description `plist_copy = H5P.copy(plist_id)` returns a copy of the property list specified by `plist_id`.

Examples Make a copy of the file creation property list for 'example.h5'.

```
fid = H5F.open('example.h5');  
fcpl = H5F.get_create_plist(fid);  
fcpl2 = H5P.copy(fcpl);
```

Purpose Create new property list

Syntax `plist = H5P.create(class_id)`

Description `plist = H5P.create(class_id)` creates a new property list as an instance of the property list class specified by `class_id`. The `class_id` input can be one of the following strings or the corresponding constant value.

```
'H5P_ATTRIBUTE_CREATE'  
'H5P_DATASET_ACCESS'  
'H5P_DATASET_CREATE'  
'H5P_DATASET_XFER'  
'H5P_DATATYPE_CREATE'  
'H5P_DATATYPE_ACCESS'  
'H5P_FILE_MOUNT'  
'H5P_FILE_CREATE'  
'H5P_FILE_ACCESS'  
'H5P_GROUP_CREATE'  
'H5P_GROUP_ACCESS'  
'H5P_LINK_CREATE'  
'H5P_LINK_ACCESS'  
'H5P_OBJECT_COPY'  
'H5P_OBJECT_CREATE'  
'H5P_STRING_CREATE'
```

`class_id` can also be an instance of a property list class.

Examples

```
fapl = H5P.create('H5P_FILE_ACCESS');  
fid = H5F.open('example.h5', 'H5F_ACC_RDONLY', fapl);
```

H5P.create

See Also

[H5P.close](#) | [H5P.get_class](#) | [H5ML.get_constant_value](#)

Purpose	Property list class
Syntax	<code>plist_class = H5P.get_class(plist_id)</code>
Description	<code>plist_class = H5P.get_class(plist_id)</code> returns the property list class for the property list specified by <code>plist_id</code> .
Examples	<pre>fid = H5F.open('example.h5'); fcpl = H5F.get_create_plist(fid); pclass = H5P.get_class(fcpl); name = H5P.get_class_name(pclass);</pre>
See Also	<code>H5P.get_class_name</code>

H5P.close_class

Purpose Close property list class

Syntax `H5P.close_class(class)`

Description `H5P.close_class(class)` closes the property list class specified by `pclass_id`.

Purpose Determine equality of property lists

Syntax `value = H5P.equal(plist1_id, plist2_id)`

Description `value = H5P.equal(plist1_id, plist2_id)` returns a positive number if the two property lists specified are equal, and zero if they are not. A negative value indicates failure.

Examples

```
fid = H5F.open('example.h5');
fapl = H5F.get_access_plist(fid);
fcpl = H5F.get_create_plist(fid);
if H5P.equal(fapl,fcpl)
    fprintf('property lists are equal\n');
else
    fprintf('property lists are not equal\n');
end
```

H5P.exist

Purpose Determine if specified property exists in property list

Syntax `value = H5P.exist(prop_id, name)`

Description `value = H5P.exist(prop_id, name)` returns a positive value if the property specified by the text string `name` exists within the property list or class specified by `prop_id`.

Examples

```
fid = H5F.open('example.h5');
fapl = H5F.get_access_plist(fid);
if H5P.exist(fapl,'sieve_buf_size')
    fprintf('sieve buffer size property exists\n');
else
    fprintf('sieve buffer size property does not exist\n');
end
```

Purpose Value of specified property in property list

Syntax `value = H5P.get(plist_id, name)`

Description `value = H5P.get(plist_id, name)` retrieves a copy of the value of the property specified by the text string `name` in the property list specified by `plist_id`. The `H5P.get` function returns the property as an array of `uint8` values. You might need to cast the value to an appropriate data type to get a meaningful result.

Examples

```
plist = H5P.create('H5P_FILE_ACCESS');  
val = H5P.get(plist, 'rdcc_w0');  
rdcc_w0 = typecast(val, 'double');
```

It is recommended to use alternative functions like `H5P.get_chunk`, `H5P.get_layout`, `H5P.get_size` etc., where available, to get values for the common property names.

See Also `H5P.set` | `typecast`

H5P.get_class_name

Purpose Name of property list class

Syntax `classname = H5P.get_class_name(pclass_id)`

Description `classname = H5P.get_class_name(pclass_id)` retrieves the name of the generic property list class. `classname` is a text string. If no class is found, the empty string is returned.

Examples

```
fid = H5F.open('example.h5');
fcpl = H5F.get_create_plist(fid);
pclass = H5P.get_class(fcpl);
name = H5P.get_class_name(pclass);
```

See Also `H5P.get_class`

Purpose	Identifier for parent class
Syntax	<code>pclass_obj_id = H5P.get_class_parent(pclass_id)</code>
Description	<code>pclass_obj_id = H5P.get_class_parent(pclass_id)</code> returns an identifier to the parent class object of the property class specified by <code>pclass_id</code> .
Examples	<pre>fid = H5F.open('example.h5'); fcpl = H5F.get_create_plist(fid); fcpl_class = H5P.get_class(fcpl); parent_class = H5P.get_class_parent(fcpl_class); name = H5P.get_class_name(parent_class);</pre>
See Also	<code>H5P.get_class</code> <code>H5P.get_class_name</code>

H5P.get_nprops

Purpose Query number of properties in property list or class

Syntax `nprops = H5P.get_nprops(id)`

Description `nprops = H5P.get_nprops(id)` returns the number of properties in the property list or class specified by `id`.

Examples

```
fid = H5F.open('example.h5');
fcpl = H5F.get_create_plist(fid);
nprops = H5P.get_nprops(fcpl);
```

Purpose Query size of property value in bytes

Syntax `sz = H5P.get_size(id,name)`

Description `sz = H5P.get_size(id,name)` returns the size, in bytes, of the property specified by the text string `name` in the property list or property class specified by `id`.

Examples

```
fid = H5F.open('example.h5');
fapl = H5F.get_access_plist(fid);
sz = H5P.get_size(fapl,'sieve_buf_size');
```

H5P.isa_class

Purpose Determine if property list is member of class

Syntax `output = H5P.isa_class(plist_id, pclass_id)`

Description `output = H5P.isa_class(plist_id, pclass_id)` returns a positive number if the property list specified by `plist_id` is a member of the class specified by `pclass_id`, zero if it is not, and a negative value to indicate an error.

Examples

```
fid = H5F.open('example.h5');
fcpl = H5F.get_create_plist(fid);
if H5P.isa_class(fcpl, 'H5P_FILE_ACCESS')
    fprintf('fcpl is a file access property list\n');
else
    fprintf('fcpl is not a file access property list\n');
end
```

See Also `H5P.get_class`

Purpose Iterate over properties in property list

Syntax `[output,idx_out] = H5P.iterate(id,idx_in,iter_func)`

Description `[output,idx_out] = H5P.iterate(id,idx_in,iter_func)` executes the operation `iter_func` on each property in the property object specified in `id`. The `id` input can be a property list or a property class. `idx_in` specifies the index of the next property to be processed. `output` is the value returned by the last call to `iter_func`. `idx_out` is the index of the last property processed. `iter_func` is a function handle.

The iterator function must have the following signature:

```
status = iter_func(id,prop_name)
```

`id` still identifies the property object passed into `H5P.iterate`, but `name` identifies the name of the current property.

H5P.set

Purpose Set property list value

Syntax `H5P.set(plist_id,name,value)`

Description `H5P.set(plist_id,name,value)` sets the value of the property specified by the text string name in the property list specified by `plist_id` to the value specified in `value`. The datatype of `value` must be `uint8`.

Examples

```
plist = H5P.create('H5P_FILE_ACCESS');
H5P.set(plist, 'rdcc_w0', typecast(0.8, 'uint8'));
```

It is recommended to use alternative functions like `H5P.set_chunk`, `H5P.set_layout`, `H5P.set_size`, etc., where available, to set values for the common property names.

See Also `typecast`

Purpose	B-tree split ratios
Syntax	<code>[left,middle,right] = H5P.get_btree_ratios(plist_id)</code>
Description	<code>[left,middle,right] = H5P.get_btree_ratios(plist_id)</code> returns the B-tree split ratios for the dataset transfer property list specified by <code>plist_id</code> . The <code>left</code> output specifies the B-tree split ratio for left-most nodes. <code>right</code> corresponds to the right-most nodes and lone nodes, and <code>middle</code> corresponds to all other nodes.
Examples	<pre>dxpl = H5P.create('H5P_DATASET_XFER'); [left,middle,right] = H5P.get_btree_ratios(dxpl);</pre>
See Also	<code>H5P.set_btree_ratios</code>

H5P.get_chunk_cache

Purpose	Raw data chunk cache parameters
Syntax	<code>[rdcc_nslots,rdcc_nbytes,rdcc_w0] = H5P.get_chunk_cache(dapl_id)</code>
Description	<code>[rdcc_nslots,rdcc_nbytes,rdcc_w0] = H5P.get_chunk_cache(dapl_id)</code> retrieves the number of chunk slots in the raw data chunk cache hash table (<code>rdcc_nslots</code>), the maximum possible number of bytes in the raw data chunk cache (<code>rdcc_nbytes</code>), and the preemption policy value (<code>rdcc_w0</code>) on a dataset access property list.
Examples	<pre>fid = H5F.open('example.h5'); dset_id = H5D.open(fid, '/g3/vlen3D'); dap1 = H5D.get_access_plist(dset_id); [rrdcc_nslots,rdcc_nbytes,rdcc_w0] = H5P.get_chunk_cache(dapl); H5P.close(dapl); H5D.close(dset_id); H5F.close(fid);</pre>
See Also	<code>H5P.set_chunk_cache</code>

Purpose Data access property lists for multiple files

Syntax `memb_dxpl = H5P.get_dxpl_multi(dxpl_id)`

Description `memb_dxpl = H5P.get_dxpl_multi(dxpl_id)` returns an array of data access property lists for the multifile data transfer property list specified by `dxpl_id`.

See Also `H5P.set_dxpl_multi`

H5P.get_edc_check

Purpose Determine if error detection is enabled

Syntax `check = H5P.get_edc_check(plist_id)`

Description `check = H5P.get_edc_check(plist_id)` queries the dataset transfer property list, specified by `plist_id`, to determine whether error detection is enabled for data read operations. Returns either `H5Z_ENABLE_EDC` or `H5Z_DISABLE_EDC`.

Examples

```
dxpl = H5P.create('H5P_DATASET_XFER');
check = H5P.get_edc_check(dxpl);
switch(check)
    case H5ML.get_constant_value('H5Z_ENABLE_EDC')
        fprintf('error detection enabled\n');
    case H5ML.get_constant_value('H5Z_DISABLE_EDC');
        fprintf('error detection disabled\n');
end
```

See Also `H5P.set_edc_check`

Purpose	Number of I/O vectors
Syntax	<code>sz = H5P.get_hyper_vector_size(dxpl_id)</code>
Description	<code>sz = H5P.get_hyper_vector_size(dxpl_id)</code> returns the number of I/O vectors to be read/written in hyperslab I/O.
Examples	<pre>dxpl = H5P.create('H5P_DATASET_XFER'); sz = H5P.get_hyper_vector_size(dxpl);</pre>
See Also	<code>H5P.set_hyper_vector_size</code>

H5P.set_btree_ratios

Purpose Set B-tree split ratios for dataset transfer

Syntax `H5P.set_btree_ratios(plist_id,left,middle,right)`

Description `H5P.set_btree_ratios(plist_id,left,middle,right)` sets the B-tree split ratios for the dataset transfer property list specified by `plist_id`. The `left` argument specifies the B-tree split ratio for left-most nodes. `right` specifies the B-tree split ratio for right-most nodes and lone nodes. `middle` specifies the B-tree split ratio for all other nodes.

Examples

```
dxpl = H5P.create('H5P_DATASET_XFER');  
H5P.set_btree_ratios(dxpl, 0.2, 0.6, 0.95);
```

See Also `H5P.get_btree_ratios`

Purpose	Set raw data chunk cache parameters
Syntax	<code>H5P.set_chunk_cache(dapl_id, rdcc_nslots, rdcc_nbytes, rdcc_w0)</code>
Description	<code>H5P.set_chunk_cache(dapl_id, rdcc_nslots, rdcc_nbytes, rdcc_w0)</code> sets the number of elements (<code>rdcc_nslots</code>), the total number of bytes (<code>rdcc_nbytes</code>), and the preemption policy value (<code>rdcc_w0</code>) in the raw data chunk cache.
Examples	<pre>fid = H5F.open('example.h5'); dset_id = H5D.open(fid, '/g3/vlen3D'); dapl = H5D.get_access_plist(dset_id); H5P.set_chunk_cache(dapl, 500, 1e6, 0.7); H5P.close(dapl); H5D.close(dset_id); H5F.close(fid);</pre>
See Also	<code>H5P.get_chunk_cache</code>

H5P.set_dxpl_multi

Purpose Set data transfer property list for multifile driver

Syntax `H5P.set_dxpl_multi(dxpl_id, memb_dxpl)`

Description `H5P.set_dxpl_multi(dxpl_id, memb_dxpl)` sets the data transfer property list `dxpl_id` to use the multifile driver. `memb_dxpl` is an array of data access property lists.

See Also `H5P.get_dxpl_multi`

Purpose Enable error detection for dataset transfer

Syntax `H5P.set_edc_check(plist_id,check)`

Description `H5P.set_edc_check(plist_id,check)` sets the dataset transfer property list specified by `plist_id` to enable or disable error detection when reading data. `check` can have the value `H5Z_ENABLE_EDC` or `H5Z_DISABLE_EDC`.

Examples Disable error detection for a default dataset transfer property list.

```
dxpl = H5P.create('H5P_DATASET_XFER');  
H5P.set_edc_check(dxpl, 'H5Z_DISABLE_EDC');
```

See Also `H5P.get_edc_check`

H5P.set_hyper_vector_size

Purpose	Set number of I/O vectors for hyperslab I/O
Syntax	<code>H5P.set_hyper_vector_size(dxpl_id,size)</code>
Description	<code>H5P.set_hyper_vector_size(dxpl_id,size)</code> sets the number of I/O vectors to be accumulated in memory before being issued to the lower levels of the HDF5 library for reading or writing the actual data. <code>dxpl_id</code> is a dataset transfer property list identifier. <code>size</code> specifies the number of I/O vectors to accumulate in memory for I/O operations.
Examples	<pre>dxpl = H5P.create('H5P_DATASET_XFER'); H5P.set_hyper_vector_size(dxpl,2048);</pre>
See Also	<code>H5P.get_hyper_vector_size</code>

Purpose	Determine availability of all filters
Syntax	<code>value = H5P.all_filters_avail(dcpl_id)</code>
Description	<code>value = H5P.all_filters_avail(dcpl_id)</code> returns a positive value if all of the filters set in the dataset creation property list <code>dcpl_id</code> are currently available, and zero if they are not. A negative value indicates failure.
Examples	<pre>fid = H5F.open('example.h5'); dset_id = H5D.open(fid, '/g3/float'); dcpl = H5D.get_create_plist(dset_id); if H5P.all_filters_avail(dcpl) fprintf('all filters available\n'); else fprintf('all filters not available\n'); end H5P.close(dcpl); H5D.close(dset_id); H5F.close(fid);</pre>
See Also	<code>H5P.set_filter</code>

H5P.fill_value_defined

Purpose Determine if fill value is defined

Syntax `fvstatus = H5P.fill_value_defined(plist_id)`

Description `fvstatus = H5P.fill_value_defined(plist_id)` determines whether a fill value is defined in the dataset creation property list `plist_id`. The `fvstatus` output can have any of the following values: `H5D_FILL_VALUE_UNDEFINED`, `H5D_FILL_VALUE_DEFAULT`, or `H5D_FILL_VALUE_USER_DEFINED`.

Examples

```
fid = H5F.open('example.h5');
dset_id = H5D.open(fid, '/g3/float');
dcpl = H5D.get_create_plist(dset_id);
fvstatus = H5P.fill_value_defined(dcpl);
switch(fvstatus)
    case H5ML.get_constant_value('H5D_FILL_VALUE_UNDEFINED')
        fprintf('fill value undefined\n');
    case H5ML.get_constant_value('H5D_FILL_VALUE_DEFAULT')
        fprintf('fill value set to default\n');
    case H5ML.get_constant_value('H5D_FILL_VALUE_USER_DEFINED')
        fprintf('fill value is user defined\n');
end
```

See Also `H5P.get_fill_value` | `H5P.set_fill_value`

Purpose Return timing of storage space allocation

Syntax `alloc_time = H5P.get_alloc_time(plist_id)`

Description `alloc_time = H5P.get_alloc_time(plist_id)` retrieves the timing for storage space allocation from the dataset creation property list specified by `plist_id`. The `alloc_time` output can have any of the following values: `H5D_ALLOC_TIME_DEFAULT`, `H5D_ALLOC_TIME_EARLY`, `H5D_ALLOC_TIME_INCR`, or `H5D_ALLOC_TIME_LATE`.

Examples

```
fid = H5F.open('example.h5');
dset_id = H5D.open(fid, '/g3/integer');
dcpl = H5D.get_create_plist(dset_id);
alloc_time = H5P.get_alloc_time(dcpl);
switch(alloc_time)
    case H5ML.get_constant_value('H5D_ALLOC_TIME_DEFAULT')
        fprintf('allocation time is default\n');
    case H5ML.get_constant_value('H5D_ALLOC_TIME_EARLY')
        fprintf('allocation time is dataset creation time\n');
    case H5ML.get_constant_value('H5D_ALLOC_TIME_INCR')
        fprintf('allocation time is incremental\n');
    case H5ML.get_constant_value('H5D_ALLOC_TIME_LATE')
        fprintf('allocation time is when data is first written\n');
end
```

H5P.get_chunk

Purpose Return size of chunks

Syntax `[rank,h5_chunk_dims] = H5P.get_chunk(plist_id)`

Description `[rank,h5_chunk_dims] = H5P.get_chunk(plist_id)` retrieves the size of chunks for the raw data of a chunked layout dataset for the dataset creation property list specified by `plist_id`.

Note The HDF5 library uses C-style ordering for multidimensional arrays, while MATLAB uses FORTRAN-style ordering. The `h5_chunk_dims` parameter assumes C-style ordering. Please consult "Using the MATLAB Low-Level HDF5 Functions" in the MATLAB documentation for more information.

Examples

```
fid = H5F.open('example.h5');
dset_id = H5D.open(fid, '/g4/time');
dcpl = H5D.get_create_plist(dset_id);
[rank,chunk_dims] = H5P.get_chunk(dcpl);
H5D.close(dset_id);
H5F.close(fid);
```

See Also `H5P.set_chunk`

Purpose Return information about external file

Syntax `[name,offset,size] = H5P.get_external(plist_id,idx)`

Description `[name,offset,size] = H5P.get_external(plist_id,idx)` returns information about the external file specified by the dataset creation property list `plist_id`. The `idx` specifies the external file index, which is a number from zero to `N-1`, where `N` is the value returned by `H5P.get_external_count`. The `name` output returns the name of the external file (limited by 2048 characters). The `offset` output returns the location in bytes, from the beginning of the external file, where the data starts. The `size` output returns the size of the external data.

See Also `H5P.get_external_count`

H5P.get_external_count

Purpose Return count of external files

Syntax `num_files = H5P.get_external_count(plist_id)`

Description `num_files = H5P.get_external_count(plist_id)` returns the number of external files for the dataset creation property list, `plist_id`.

See Also `H5P.get_external`

Purpose Return time when fill values are written to dataset

Syntax `fill_time = H5P.get_fill_time(plist_id)`

Description `fill_time = H5P.get_fill_time(plist_id)` returns the time when fill values are written to the dataset specified by the dataset creation property list `plist_id`. The `fill_time` output is one of the following values: `H5D_FILL_TIME_IFSET`, `H5D_FILL_TIME_ALLOC`, or `H5D_FILL_TIME_NEVER`.

Examples

```
fid = H5F.open('example.h5');
dset_id = H5D.open(fid, '/g3/integer');
dcpl = H5D.get_create_plist(dset_id);
fill_time = H5P.get_fill_time(dcpl);
switch(fill_time)
    case H5ML.get_constant_value('H5D_FILL_TIME_IFSET')
        fprintf('upon allocation if and only if fill value set by user\n');
    case H5ML.get_constant_value('H5D_FILL_TIME_ALLOC')
        fprintf('written when storage space is allocated\n');
    case H5ML.get_constant_value('H5D_FILL_TIME_NEVER')
        fprintf('fill values are never written\n');
end
```

See Also `H5P.get_fill_time` | `H5P.set_fill_value`

H5P.get_fill_value

Purpose Return dataset fill value

Syntax `value = H5P.get_fill_value(plist_id,type_id)`

Description `value = H5P.get_fill_value(plist_id,type_id)` returns the dataset fill value defined in the dataset creation property list `plist_id`. The `type_id` input specifies the datatype of the returned fill value.

Examples

```
fid = H5F.open('example.h5');
dset_id = H5D.open(fid, '/g3/integer');
dcpl = H5D.get_create_plist(dset_id);
type_id = H5T.copy('H5T_NATIVE_INT');
fill_value = H5P.get_fill_value(dcpl,type_id);
```

See Also [H5P.set_fill_value](#) | [H5P.get_fill_time](#) | [H5P.set_fill_time](#)

Purpose

Return information about filter in pipeline

Syntax

```
[filter,flags,cd_values,name] = H5P.get_filter(plist_id,index)
[filter,flags,cd_values,name,filter_config] = H5P.get_filter(plist_id,
index)
```

Description

[filter,flags,cd_values,name] = H5P.get_filter(plist_id,index) returns information about the filter, specified by its filter index, in the filter pipeline, specified by the property list with which it is associated. This interface corresponds to the 1.6 version of H5Pget_filter in the HDF5 library.

[filter,flags,cd_values,name,filter_config] = H5P.get_filter(plist_id, index) returns information about the filter, specified by its filter index, in the filter pipeline, specified by the property list with which it is associated. It also returns information about the filter. Consult the HDF5 documentation for H5Zget_filter_info for information about filter_config. This interface corresponds to the 1.8 version of H5Pget_filter in the HDF5 library.

See Also

H5P.get_nfilters | H5P.get_filter_by_id | H5P.modify_filter | H5P.remove_filter

H5P.get_filter_by_id

Purpose	Return information about specified filter
Syntax	<code>[flags,cd_values,name,filter_config] = H5P.get_filter_by_id(plist_id, idx)</code>
Description	<code>[flags,cd_values,name,filter_config] = H5P.get_filter_by_id(plist_id, idx)</code> returns information about the filter specified by the filter id, idx.
See Also	<code>H5P.get_filter</code> <code>H5P.get_nfilters</code> <code>H5P.modify_filter</code> <code>H5P.remove_filter</code>

Purpose Determine layout of raw data for dataset

Syntax `layout = H5P.get_layout(dcpl)`

Description `layout = H5P.get_layout(dcpl)` returns the layout of the raw data for the dataset specified by the dataset creation property list, `dcpl`. Possible values are: `H5D_COMPACT`, `H5D_CONTIGUOUS`, or `H5D_CHUNKED`.

Examples

```
fid = H5F.open('example.h5');
dset_id = H5D.open(fid, '/g3/integer');
dcpl = H5D.get_create_plist(dset_id);
layout = H5P.get_layout(dcpl);
switch(layout)
    case H5ML.get_constant_value('H5D_COMPACT')
        fprintf('layout is compact\n');
    case H5ML.get_constant_value('H5D_CONTIGUOUS')
        fprintf('layout is contiguous\n');
    case H5ML.get_constant_value('H5D_CHUNKED')
        fprintf('layout is chunked\n');
end
```

See Also `H5P.set_layout`

H5P.get_nfilters

Purpose Return number of filters in pipeline

Syntax `num_filters = H5P.get_nfilters(plist_id)`

Description `num_filters = H5P.get_nfilters(plist_id)` returns the number of filters defined in the filter pipeline associated with the dataset creation property list, `plist_id`.

Examples

```
fid = H5F.open('example.h5');
dset_id = H5D.open(fid, '/g4/world');
dcpl = H5D.get_create_plist(dset_id);
num_filters = H5P.get_nfilters(dcpl);
H5D.close(dset_id);
H5F.close(fid);
```

See Also `H5P.get_filter` | `H5P.get_filter_by_id` | `H5P.modify_filter` | `H5P.remove_filter`

Purpose	Modify filter in pipeline
Syntax	<code>H5P.modify_filter(plist_id,filter_id,flags,cd_values)</code>
Description	<code>H5P.modify_filter(plist_id,filter_id,flags,cd_values)</code> modifies the specified filter in the filter pipeline. <code>plist_id</code> is a property list identifier. <code>flags</code> is a bit vector specifying certain general properties of the filter. <code>cd_values</code> specifies auxiliary data for the filter.
See Also	<code>H5P.get_filter</code> <code>H5P.get_nfilters</code> <code>H5P.get_filter_by_id</code> <code>H5P.remove_filter</code>

H5P.remove_filter

Purpose Remove filter from property list

Syntax `H5P.remove_filter(plist_id,filter)`

Description `H5P.remove_filter(plist_id,filter)` removes the specified filter from the filter pipeline. `plist_id` is the dataset creation property list identifier.

See Also `H5P.get_filter` | `H5P.get_nfilters` | `H5P.get_filter_by_id` | `H5P.modify_filter`

Purpose	Set timing for storage space allocation
Syntax	<code>H5P.set_alloc_time(plist_id,alloc_time)</code>
Description	<code>H5P.set_alloc_time(plist_id,alloc_time)</code> sets the timing for the allocation of storage space for a dataset's raw data. <code>plist_id</code> is a dataset creation property list. <code>alloc_time</code> can have any of the following values: <code>H5D_ALLOC_TIME_DEFAULT</code> , <code>H5D_ALLOC_TIME_EARLY</code> , <code>H5D_ALLOC_TIME_INC</code> , or <code>H5D_ALLOC_TIME_LATE</code> .
Examples	Create a 1000x500 double precision dataset with late allocation time. <pre>fid = H5F.create('myfile.h5'); type_id = H5T.copy('H5T_NATIVE_DOUBLE'); dims = [1000 500]; h5_dims = fliplr(dims); h5_maxdims = h5_dims; space_id = H5S.create_simple(2,h5_dims,h5_maxdims); dcpl = H5P.create('H5P_DATASET_CREATE'); alloc_time = H5ML.get_constant_value('H5D_ALLOC_TIME_LATE'); H5P.set_alloc_time(dcpl,alloc_time); dset_id = H5D.create(fid,'DS',type_id,space_id,dcpl); H5D.close(dset_id); H5F.close(fid);</pre>
See Also	<code>H5P.get_alloc_time</code>

H5P.set_chunk

Purpose	Set chunk size
Syntax	<code>H5P.set_chunk(plist_id,h5_chunk_dims)</code>
Description	<code>H5P.set_chunk(plist_id,h5_chunk_dims)</code> sets the size of the chunks used to store a chunked layout dataset. <code>plist_id</code> is a dataset creation property list identifier. <code>h5_chunk_dims</code> is an array specifying the size, in dataset elements, of each chunk.

Note The HDF5 library uses C-style ordering for multidimensional arrays, while MATLAB uses FORTRAN-style ordering. The `h5_chunk_dims` parameter assumes C-style ordering. Please consult "Using the MATLAB Low-Level HDF5 Functions" in the MATLAB documentation for more information.

Examples

Create a two dimensional double precision dataset that has an initial size of [512 1024], but is also unlimited in both dimensions and has a chunk size of [512 1024].

```
fid = H5F.create('myfile.h5');
type_id = H5T.copy('H5T_NATIVE_DOUBLE');
unlimited = H5ML.get_constant_value('H5S_UNLIMITED');
dims = [512 1024];
h5_dims = fliplr(dims);
h5_maxdims = [unlimited unlimited];
space_id = H5S.create_simple(2,[1024 512],h5_maxdims);
dcpl = H5P.create('H5P_DATASET_CREATE');
chunk_dims = [512 1024];
h5_chunk_dims = fliplr(chunk_dims);
H5P.set_chunk(dcpl,h5_chunk_dims);
dset_id = H5D.create(fid,'DS',type_id,space_id,dcpl);
H5D.close(dset_id);
H5F.close(fid);
```

See Also

[H5P.get_chunk](#)

H5P.set_deflate

Purpose Set compression method and compression level

Syntax H5P.set_deflate(plist_id,level)

Description H5P.set_deflate(plist_id,level) sets the compression method for the dataset creation property list specified by plist_id to H5D_COMPRESS_DEFLATE. level specifies the compression level as a value from 0 and 9, inclusive. Lower values results in less compression.

Examples Create a two dimensional double precision dataset that has an initial size of [512 1024], but is also unlimited in both dimensions and has a chunk size of [512 1024] and a compression level of 5.

```
fid = H5F.create('myfile.h5');
type_id = H5T.copy('H5T_NATIVE_DOUBLE');
unlimited = H5ML.get_constant_value('H5S_UNLIMITED');
dims = [512 1024];
h5_dims = fliplr(dims);
h5_maxdims = [unlimited unlimited];
space_id = H5S.create_simple(2,[1024 512],h5_maxdims);
dcpl = H5P.create('H5P_DATASET_CREATE');
chunk_dims = [512 1024];
h5_chunk_dims = fliplr(chunk_dims);
H5P.set_chunk(dcpl,h5_chunk_dims);
H5P.set_deflate(dcpl,5);
dset_id = H5D.create(fid,'DS',type_id,space_id,dcpl);
H5D.close(dset_id);
H5F.close(fid);
```

Purpose	Add additional file to external file list
Syntax	<code>H5P.set_external(plist_id,name,offset,nbytes)</code>
Description	<code>H5P.set_external(plist_id,name,offset,nbytes)</code> adds the external file specified by name to the list of external files in the dataset creation property list, <code>plist_id</code> . The <code>offset</code> argument specifies the location, in bytes, where the data starts relative to the beginning of the file. <code>nbytes</code> is the number of bytes reserved in the file for the data. <code>nbytes</code> may also be given as 'H5F_UNLIMITED', in which case the external file may be of unlimited size.
Examples	<p>Create a dataset with an unlimited size external file.</p> <pre>fid = H5F.create('myfile.h5'); type_id = H5T.copy('H5T_NATIVE_DOUBLE'); dims = [100 50]; h5_dims = fliplr(dims); h5_maxdims = h5_dims; space_id = H5S.create_simple(2,h5_dims,h5_maxdims); dcpl = H5P.create('H5P_DATASET_CREATE'); H5P.set_external(dcpl,'myexternalfile.dat',0,'H5F_UNLIMITED'); dset_id = H5D.create(fid,'DS',type_id,space_id,dcpl); data = rand(dims); dxpl = 'H5P_DEFAULT'; H5D.write(dset_id,'H5ML_DEFAULT','H5S_ALL','H5S_ALL',dxpl,data); H5D.close(dset_id); H5F.close(fid);</pre>
See Also	<code>H5P.get_external</code> <code>H5ML.get_constant_value</code>

H5P.set_fill_time

Purpose Set time when fill values are written to dataset

Syntax `H5P.set_fill_time(plist_id,fill_time)`

Description `H5P.set_fill_time(plist_id,fill_time)` sets the timing for writing fill values to a dataset in the dataset creation property list `plist_id`. The timing can be specified by one of the following values: `H5D_FILL_TIME_IFSET`, `H5D_FILL_TIME_ALLOC`, or `H5D_FILL_TIME_NEVER`.

Examples

```
fid = H5F.create('myfile.h5');
type_id = H5T.copy('H5T_NATIVE_DOUBLE');
dims = [100 50];
h5_dims = fliplr(dims);
h5_maxdims = h5_dims;
space_id = H5S.create_simple(2,h5_dims,h5_maxdims);
dcpl = H5P.create('H5P_DATASET_CREATE');
fill_time = H5ML.get_constant_value('H5D_FILL_TIME_ALLOC');
H5P.set_fill_time(dcpl,fill_time);
dset_id = H5D.create(fid,'DS',type_id,space_id,dcpl);
H5D.close(dset_id);
H5F.close(fid);
```

See Also `H5P.get_fill_time` | `H5P.get_fill_value` | `H5P.set_fill_value`

Purpose	Set fill value for dataset creation property list
Syntax	<code>H5P.set_fill_value(plist_id,type_id,value)</code>
Description	<code>H5P.set_fill_value(plist_id,type_id,value)</code> sets the fill value for a the dataset creation property list specified by <code>plist_id</code> . The <code>value</code> argument specifies the fill value. <code>type_id</code> specifies the datatype of the fill value. Setting <code>value</code> to an empty array indicates that the fill value is to be undefined.
Examples	<p>Create a double precision dataset with a fill value of -999.</p> <pre>fid = H5F.create('myfile.h5'); type_id = H5T.copy('H5T_NATIVE_DOUBLE'); dims = [100 50]; h5_dims = flip1r(dims); h5_maxdims = h5_dims; space_id = H5S.create_simple(2,h5_dims,h5_maxdims); dcpl = H5P.create('H5P_DATASET_CREATE'); fill_time = H5ML.get_constant_value('H5D_FILL_TIME_ALLOC'); H5P.set_fill_time(dcpl,fill_time); type_id = H5T.copy('H5T_NATIVE_DOUBLE'); H5P.set_fill_value(dcpl,type_id,-999); dset_id = H5D.create(fid,'DS',type_id,space_id,dcpl); H5D.close(dset_id); H5F.close(fid);</pre>

H5P.set_filter

Purpose Add filter to filter pipeline

Syntax `H5P.set_filter(plist_id,filter,flags,cd_values)`

Description `H5P.set_filter(plist_id,filter,flags,cd_values)` adds the specified filter and corresponding properties to the end of an output filter pipeline. `plist_id` is a property list identifier. `filter` is a filter identifier and should correspond to one of the following values:

`H5P_FILTER_DEFLATE`

`H5P_FILTER_SHUFFLE`

`H5P_FILTER_FLETCHER32`

`flags` is a bit vector specifying properties of the filter. `cd_values` is an array that contains auxiliary data for the filter.

See Also `H5P.set_deflate` | `H5P.set_fletcher32` | `H5P.set_shuffle`

Purpose Set Fletcher32 checksum filter in dataset creation

Syntax `H5P.set_fletcher32(plist_id)`

Description `H5P.set_fletcher32(plist_id)` sets the Fletcher32 checksum filter in the dataset creation property list specified by `plist_id`. The dataset creation property list must also have chunking enabled.

Examples

```
fid = H5F.create('myfile.h5');
type_id = H5T.copy('H5T_NATIVE_DOUBLE');
dims = [100 200];
h5_dims = fliplr(dims);
space_id = H5S.create_simple(2,dims,[]);
dcpl = H5P.create('H5P_DATASET_CREATE');
chunk_dims = [10 20];
h5_chunk_dims = fliplr(chunk_dims);
H5P.set_chunk(dcpl,h5_chunk_dims);
H5P.set_fletcher32(dcpl);
dset_id = H5D.create(fid,'DS',type_id,space_id,dcpl);
H5D.close(dset_id);
H5F.close(fid);
```

See Also `H5P.set_deflate` | `H5P.set_shuffle`

H5P.set_layout

Purpose Set type of storage for dataset

Syntax `H5P.set_layout(dcpl,layout)`

Description `H5P.set_layout(dcpl,layout)` sets the type of storage used to store the raw data for the dataset creation property list, `dcpl`. The `layout` argument specifies the type of storage layout for raw data: `H5D_COMPACT`, `H5D_CONTIGUOUS`, or `H5D_CHUNKED`.

Examples

```
fid = H5F.create('myfile.h5');
type_id = H5T.copy('H5T_NATIVE_DOUBLE');
dims = [100 200];
h5_dims = fliplr(dims);
space_id = H5S.create_simple(2,dims,[]);
dcpl = H5P.create('H5P_DATASET_CREATE');
layout = H5ML.get_constant_value('H5D_CONTIGUOUS');
H5P.set_layout(dcpl,layout);
dset_id = H5D.create(fid,'DS',type_id,space_id,dcpl);
H5D.close(dset_id);
H5F.close(fid);
```

See Also `H5P.get_layout` | `H5P.set_chunk`

Purpose Set N-Bit filter

Syntax `H5P.set_nbit(plist_id)`

Description `H5P.set_nbit(plist_id)` sets the N-Bit filter, `H5Z_FILTER_NBIT`, in the dataset creation property list `plist_id`.

H5P.set_scaleoffset

Purpose Set Scale-Offset filter

Syntax `H5P.set_scaleoffset(plistId, scaleType, scaleFactor)`

Description `H5P.set_scaleoffset(plistId, scaleType, scaleFactor)` sets the Scale-Offset filter, `H5Z_FILTER_SCALEOFFSET`, for a dataset. For integer data types, the parameter `scaleType` should be set to the enumerated value `H5Z_S0_INT`. For floating-point data types, the `scaleType` should be the enumerated value `H5Z_S0_FLOAT_DSCALE`. Chunking must already be enabled on the dataset creation property list.

See Also `H5P.set_chunk`

Purpose Set shuffle filter

Syntax H5P.set_shuffle(plist_id)

Description H5P.set_shuffle(plist_id) sets the shuffle filter, H5Z_FILTER_SHUFFLE, in the dataset creation property list plist_id. Compression must be enabled on the dataset creation property list in order to use the shuffle filter, and best results are usually obtained when the shuffle filter is set immediately prior to setting the deflate filter.

Examples

```
fid = H5F.create('myfile.h5');
type_id = H5T.copy('H5T_NATIVE_DOUBLE');
dims = [100 200];
h5_dims = fliplr(dims);
space_id = H5S.create_simple(2,dims,[]);
dcpl = H5P.create('H5P_DATASET_CREATE');
chunk_dims = [10 20];
h5_chunk_dims = fliplr(chunk_dims);
H5P.set_chunk(dcpl,h5_chunk_dims);
H5P.set_shuffle(dcpl);
H5P.set_deflate(dcpl,5);
dset_id = H5D.create(fid,'DS',type_id,space_id,dcpl);
H5D.close(dset_id);
H5F.close(fid);
```

See Also H5P.set_deflate

H5P.get_alignment

Purpose Retrieve alignment properties

Syntax [threshold,alignment] = H5P.get_alignment(plist_id)

Description [threshold,alignment] = H5P.get_alignment(plist_id) retrieves the current settings for alignment properties from the file access property list specified by plist_id.

Examples

```
fid = H5F.open('example.h5');  
fapl = H5F.get_access_plist(fid);  
[threshold,alignment] = H5P.get_alignment(fapl);  
H5P.close(fapl);  
H5F.close(fid);
```

Purpose Low-level file driver

Syntax `driver_id = H5P.get_driver(plist_id)`

Description `driver_id = H5P.get_driver(plist_id)` returns the identifier of the low-level file driver associated with the file access property list or data transfer property list specified by `plist_id`. See HDF5 documentation for a list of valid return values.

Examples

```
fid = H5F.open('example.h5');
fapl = H5F.get_access_plist(fid);
driver_id = H5P.get_driver(fapl);
if ( driver_id == H5ML.get_constant_value('H5FD_SEC2') )
    fprintf('File driver is H5FD_SEC2.\n');
end
H5P.close(fapl);
H5F.close(fid);
```

See Also `H5ML.get_constant_value`

H5P.get_family_offset

Purpose Offset for family file driver

Syntax `offset = H5P.get_family_offset(fapl_id)`

Description `offset = H5P.get_family_offset(fapl_id)` retrieves the value of `offset` from the file access property list, `fapl_id`. `offset` is the offset of the data in the HDF5 file that is stored on disk in the selected member file in a family of files.

See Also `H5P.set_family_offset`

Purpose	Information about core file driver properties
Syntax	<code>[increment,backing_store] = H5P.get_fapl_core(fapl_id)</code>
Description	<code>[increment,backing_store] = H5P.get_fapl_core(fapl_id)</code> queries the H5FD_CORE driver properties as set by <code>H5P.set_fapl_core</code> . The <code>fapl_id</code> argument specifies a file access property list. The return value <code>increment</code> specifies the size, in bytes, of memory increments. <code>backing_store</code> is a Boolean flag indicating whether to write the file contents to disk when the file is closed.
See Also	<code>H5P.set_fapl_core</code>

H5P.get_fapl_family

Purpose File access property list information

Syntax [memb_size,memb_fapl_id] = H5P.get_fapl_family(fapl_id)

Description [memb_size,memb_fapl_id] = H5P.get_fapl_family(fapl_id)
returns the size in bytes of each file member and the identifier of the file access property list for use with the family driver specified by fapl_id.

See Also H5P.set_fapl_family

Purpose	Information about multifile access property list
Syntax	<pre>[memb_map,memb_fapl,memb_name,memb_addr, relax] = H5P.get_fapl_multi(fapl_id)</pre>
Description	<p>[memb_map,memb_fapl,memb_name,memb_addr, relax] = H5P.get_fapl_multi(fapl_id) returns information about the multifile access property list specified by fapl_id. The memb_map output maps memory usage types to other memory usage types. memb_fapl is a property list for each memory usage type. memb_name is the name generator for names of member files. relax is a Boolean value that, when non-zero, allows read-only access to incomplete file sets.</p>
See Also	H5P.set_fapl_multi

H5P.get_fcclose_degree

Purpose File close degree

Syntax `degree = H5P.get_fcclose_degree(fapl_id)`

Description `degree = H5P.get_fcclose_degree(fapl_id)` returns the current setting of the file close degree property `fc_degree` in the file access property list specified by `fapl_id`. Possible return values are: `H5F_CLOSE_DEFAULT`, `H5F_CLOSE_WEAK`, `H5F_CLOSE_SEMI`, or `H5F_CLOSE_STRONG`.

Examples

```
fid = H5F.open('example.h5');
fapl = H5F.get_access_plist(fid);
degree = H5P.get_fcclose_degree(fapl);
switch(degree)
    case H5ML.get_constant_value('H5F_CLOSE_DEFAULT')
        fprintf('file close degree is default\n');
    case H5ML.get_constant_value('H5F_CLOSE_WEAK')
        fprintf('file close degree is weak\n');
    case H5ML.get_constant_value('H5F_CLOSE_SEMI')
        fprintf('close degree is semi\n');
    case H5ML.get_constant_value('H5F_CLOSE_STRONG')
        fprintf('close degree is strong\n');
end
H5P.close(fapl);
H5F.close(fid);
```

See Also `H5P.set_fcclose_degree`

Purpose	Library version bounds settings
Syntax	<code>[low,high] = H5P.get_libver_bounds(fapl_id)</code>
Description	<code>[low,high] = H5P.get_libver_bounds(fapl_id)</code> gets bounds on library version bounds settings that control the format versions used when creating objects in the file with access property list <code>fapl_id</code> .
Examples	<pre>fid = H5F.open('example.h5'); fapl = H5F.get_access_plist(fid); [low,high] = H5P.get_libver_bounds(fapl);</pre>
See Also	<code>H5F.get_access_plist</code> <code>H5P.set_libver_bounds</code>

H5P.get_gc_references

Purpose Garbage collection references setting

Syntax `gc_ref = H5P.get_gc_references(fapl_id)`

Description `gc_ref = H5P.get_gc_references(fapl_id)` returns the current setting for the garbage collection references property from the file access property list specified by `fapl_id`. If `gc_ref` is 1, garbage collection is on; if 0, garbage collection is off.

Examples

```
fid = H5F.open('example.h5');
fapl = H5F.get_access_plist(fid);
gc_ref = H5P.get_gc_references(fapl);
H5P.close(fapl);
H5F.close(fid);
```

See Also `H5P.set_gc_references`

Purpose	Metadata cache configuration
Syntax	<code>config_struct = H5P.get_mdc_config(plist_id)</code>
Description	<code>config_struct = H5P.get_mdc_config(plist_id)</code> returns the current metadata cache configuration from the indicated file access property list.
Examples	<pre>fid = H5F.open('example.h5'); fapl = H5F.get_access_plist(fid); config = H5P.get_mdc_config(fapl); H5P.close(fapl); H5F.close(fid);</pre>
See Also	<code>H5P.set_mdc_config</code>

H5P.get_meta_block_size

Purpose Metadata block size setting

Syntax `sz = H5P.get_meta_block_size(fapl_id)`

Description `sz = H5P.get_meta_block_size(fapl_id)` returns the current minimum size, in bytes, of new metadata block allocations.

Examples

```
fid = H5F.open('example.h5');
fapl = H5F.get_access_plist(fid);
sz = H5P.get_meta_block_size(fapl);
H5P.close(fapl);
H5F.close(fid);
```

See Also `H5P.set_meta_block_size`

Purpose Type of data property for MULTI driver

Syntax `type = H5P.get_multi_type(fapl_id)`

Description `type = H5P.get_multi_type(fapl_id)` returns the type of data setting from the file access or data transfer property list, `fapl_id`.

This function should only be used with an HDF5 file written as a set of files with the MULTI file driver.

See Also `H5P.set_multi_type`

H5P.get_sieve_buf_size

Purpose Maximum data sieve buffer size

Syntax `sz = H5P.get_sieve_buf_size(fapl_id)`

Description `sz = H5P.get_sieve_buf_size(fapl_id)` returns the current maximum size of the data sieve buffer.

Examples

```
fid = H5F.open('example.h5');
fapl = H5F.get_access_plist(fid);
sz = H5P.get_sieve_buf_size(fapl);
H5P.close(fapl);
H5F.close(fid);
```

See Also `H5P.set_sieve_buf_size`

H5P.get_small_data_block_size

Purpose	Small data block size setting
Syntax	<code>sz = H5P.get_small_data_block_size(fapl_id)</code>
Description	<code>sz = H5P.get_small_data_block_size(fapl_id)</code> returns the current setting for the size of the small data block. <code>fapl_id</code> is a file access property list identifier.
Examples	<pre>fid = H5F.open('example.h5'); fapl = H5F.get_access_plist(fid); sz = H5P.get_small_data_block_size(fapl); H5P.close(fapl); H5F.close(fid);</pre>
See Also	<code>H5P.set_small_data_block_size</code>

H5P.set_alignment

Purpose Set alignment properties for file access property list

Syntax `H5P.set_alignment(fapl_id, threshold, alignment)`

Description `H5P.set_alignment(fapl_id, threshold, alignment)` sets the alignment properties of the file access property list specified by `fapl_id` so that any file object greater than or equal in size to `threshold` (in bytes) is aligned on an address which is a multiple of `alignment`.

In most cases the default values of `threshold` and `alignment` result in the best performance.

See Also `H5P.get_alignment`

Purpose	Set offset property for family of files
Syntax	<code>H5P.set_family_offset(fapl_id,offset)</code>
Description	<code>H5P.set_family_offset(fapl_id,offset)</code> sets offset property in the file access property list specified by <code>fapl_id</code> for low-level access to a file in a family of files. <code>offset</code> identifies a user-determined location from the beginning of the HDF5 file in bytes.
See Also	<code>H5P.get_family_offset</code>

H5P.set_fapl_core

Purpose Modify file access to use H5FD_CORE driver

Syntax H5P.set_fapl_core(fapl_id,increment,backing_store)

Description H5P.set_fapl_core(fapl_id,increment,backing_store) modifies the file access property list to use the H5FD_CORE driver. increment specifies the increment by which allocated memory is to be increased each time more memory is required. backing_store is a Boolean flag that, when non-zero, indicates the file contents should be written to disk when the file is closed.

Examples Create a file image in memory only.

```
plist = 'H5P_DEFAULT';
ndatasets = 20;
block_size = 1024*1024;
fapl = H5P.create('H5P_FILE_ACCESS');
H5P.set_fapl_core(fapl,2^16,false);
fid = H5F.create('myfile.h5','H5F_ACC_TRUNC',plist,fapl);
space_id = H5S.create_simple(1, block_size, []);
type_id = H5T.copy('H5T_IEEE_F64LE');
data = zeros(block_size,1);
for j = 1:ndatasets
    dsname = sprintf('dset%02d', j);
    fprintf('Writing dataset %s...\n',dsname);
    dsid = H5D.create(fid,dsname,type_id,space_id,'H5P_DEFAULT');
    H5D.write(dsid,'H5ML_DEFAULT',space_id,space_id,plist,data);
    H5D.close(dsid);
end
H5P.close(fapl);
H5S.close(space_id);
H5T.close(type_id);
H5F.close(fid);
dir('myfile.h5');
```

See Also H5P.get_fapl_core

Purpose

Set file access to use family driver

Syntax

```
H5P.set_fapl_family(fapl_id,memb_size,memb_fapl_id)
```

Description

H5P.set_fapl_family(fapl_id,memb_size,memb_fapl_id) sets the file access property list, specified by fapl_id, to use the family driver. memb_size is the size in bytes of each file member. memb_fapl_id is the identifier of the file access property list to be used for each family member.

Examples

```
plist = 'H5P_DEFAULT';
fapl = H5P.create('H5P_FILE_ACCESS');
H5P.set_fapl_family(fapl, 8192, plist);
fid = H5F.create('family%d.h5','H5F_ACC_TRUNC','H5P_DEFAULT',fapl);
type_id = H5T.copy('H5T_NATIVE_DOUBLE');
dims = [50 25];
h5_dims = fliplr(dims);
space_id = H5S.create_simple(2,h5_dims,[]);
dset_id = H5D.create(fid,'DS',type_id,space_id,plist)
data = reshape(1:prod(dims),dims);
H5D.write(dset_id,'H5ML_DEFAULT','H5S_ALL','H5S_ALL',plist,data);
H5P.close(fapl);
H5T.close(type_id);
H5S.close(space_id);
H5D.close(dset_id);
dir('*.*h5');
h5disp('family%d.h5');
```

See Also

H5P.get_fapl_family

H5P.set_fapl_log

Purpose Set use of logging driver

Syntax `H5P.set_fapl_log(fapl_id,logfile,flags,buf_size)`

Description `H5P.set_fapl_log(fapl_id,logfile,flags,buf_size)` modifies the file access property list, `fapl_id`, to use the logging driver `H5FD_LOG`. `logfile` is the name of the file in which the logging entries are to be recorded. `flags` is a bit mask that specifies the types of activity to log. See the HDF5 documentation for a list of available flag settings. `buf_size` specifies the size of the logging buffer.

Purpose

Set use of multifile driver

Syntax

```
H5P.set_fapl_multi(fapl_id,relax)
H5P.set_fapl_multi(fapl_id,memb_map,memb_fapl,memb_name,memb_addr,
relax)
```

Description

H5P.set_fapl_multi(fapl_id,relax) sets the file access property list, fapl_id, to access HDF5 files created with the multi-driver with default values provided by the HDF5 library. relax is a Boolean value that allows read-only access to incomplete file sets when set to 1.

H5P.set_fapl_multi(fapl_id,memb_map,memb_fapl,memb_name,memb_addr,relax) sets the file access property list to use the multifile driver. memb_map maps memory usage types to other memory usage types. memb_fapl contains a property list for each memory usage type. memb_name is a name generator for names of member files. memb_addr specifies the offsets within the virtual address space at which each type of data storage begins.

See Also

H5P.get_fapl_multi

H5P.set_fapl_sec2

Purpose Set file access for sec2 driver

Syntax H5P.set_fapl_sec2(fapl_id)

Description H5P.set_fapl_sec2(fapl_id) modifies the file access property list, fapl_id, to use the H5FD_SEC2 driver.

Examples

```
fcp1 = H5P.create('H5P_FILE_CREATE');
fapl = H5P.create('H5P_FILE_ACCESS');
H5P.set_fapl_sec2(fapl);
fid = H5F.create('myfile.h5', 'H5F_ACC_TRUNC', fcp1, fapl);
H5F.close(fid);
```

Purpose

Set file access for emulation of split file driver

Syntax

```
H5P.set_fapl_split(fapl_id,meta_ext,meta_plist_id,raw_ext,  
raw_plist_id)
```

Description

H5P.set_fapl_split(fapl_id,meta_ext,meta_plist_id,raw_ext,raw_plist_id) is a compatibility function that enables the multi-file driver to emulate the split driver from HDF5 Releases 1.0 and 1.2. meta_ext is a text string that specifies the metadata filename extension. meta_plist_id is a file access property list identifier for the metadata file. raw_ext is a text string that specifies the raw data filename extension. raw_plist_id is the file access property list identifier for the raw data file.

H5P.set_fapl_stdio

Purpose Set file access for standard I/O driver

Syntax H5P.set_fapl_stdio(fapl_id)

Description H5P.set_fapl_stdio(fapl_id) modifies the file access property list, fapl_id, to use the standard I/O driver, H5FD_STDIO.

Examples

```
fcpl = H5P.create('H5P_FILE_CREATE');
fapl = H5P.create('H5P_FILE_ACCESS');
H5P.set_fapl_stdio(fapl);
fid = H5F.create('myfile.h5', 'H5F_ACC_TRUNC', fcpl, fapl);
H5F.close(fid);
```

Purpose

Set file access for file close degree

Syntax

```
H5P.set_fcclose_degree(fapl_id,degree)
```

Description

H5P.set_fcclose_degree(fapl_id,degree) sets the file close degree property in the file access property list, fapl_id, to the value specified by degree. The degree argument can have any of the following values:

```
'H5F_CLOSE_WEAK'  
'H5F_CLOSE_SEMI'  
'H5F_CLOSE_STRONG'  
'H5F_CLOSE_DEFAULT'
```

Examples

```
fcpl = H5P.create('H5P_FILE_CREATE');  
fapl = H5P.create('H5P_FILE_ACCESS');  
H5P.set_fcclose_degree(fapl,'H5F_CLOSE_STRONG');  
fid = H5F.create('myfile.h5','H5F_ACC_TRUNC',fcpl,fapl);  
H5F.close(fid);
```

See Also

H5P.get_fcclose_degree

H5P.set_gc_references

Purpose	Set garbage collection references flag
Syntax	<code>H5P.set_gc_references(fapl_id,gc_ref)</code>
Description	<code>H5P.set_gc_references(fapl_id,gc_ref)</code> sets the flag for garbage collecting references for the file specified by the file access property list identifier, <code>fapl_id</code> . The <code>gc_ref</code> argument is a flag setting reference garbage collection to on (1) or off (0).
Examples	<pre>fcp1 = H5P.create('H5P_FILE_CREATE'); fapl = H5P.create('H5P_FILE_ACCESS'); H5P.set_gc_references(fapl,1); fid = H5F.create('myfile.h5','H5F_ACC_TRUNC',fcp1,fapl); H5F.close(fid);</pre>
See Also	<code>H5P.get_gc_references</code>

Purpose	Set library version bounds for objects
Syntax	<code>H5P.get_libver_bounds(fapl_id,low,high)</code>
Description	<code>H5P.get_libver_bounds(fapl_id,low,high)</code> sets bounds on library versions, and indirectly format versions, to be used when creating objects in the file with access property list <code>fapl_id</code> . The low argument must be set to either of <code>'H5F_LIBVER_EARLIEST'</code> , <code>'H5F_LIBVER_18'</code> or <code>'H5F_LIBVER_LATEST'</code> . The high argument must be set to <code>'H5F_LIBVER_18'</code> or <code>'H5F_LIBVER_LATEST'</code> .
Examples	<p>Create an HDF5 file where objects are created using the latest available format for each object.</p> <pre>fcp1 = H5P.create('H5P_FILE_CREATE'); fapl = H5P.create('H5P_FILE_ACCESS'); H5P.set_libver_bounds(fapl,'H5F_LIBVER_LATEST','H5F_LIBVER_LATEST'); fid = H5F.create('myfile.h5','H5F_ACC_TRUNC',fcp1,fapl);</pre>
See Also	<code>H5P.get_libver_bounds</code> <code>H5ML.get_constant_value</code>

H5P.set_mdc_config

Purpose Set initial metadata cache configuration

Syntax `H5P.set_mdc_config(plist_id,config_struct)`

Description `H5P.set_mdc_config(plist_id,config_struct)` sets the initial metadata cache configuration in the indicated file access property list to the supplied values. Before using this function, you should retrieve the current configuration using `H5P.get_mdc_config`.

Many of the fields in the structure, `config_struct`, are intended to be used only in close consultation with the HDF5 Group itself.

See Also `H5P.get_mdc_config`

Purpose	Set minimum metadata block size
Syntax	<code>H5P.set_meta_block_size(fapl_id,size)</code>
Description	<code>H5P.set_meta_block_size(fapl_id,size)</code> sets the minimum metadata block size for the file access property list specified by <code>fapl_id</code> . The <code>size</code> argument specifies minimum size, in bytes, of metadata block allocations.
Examples	<pre>fcpl = H5P.create('H5P_FILE_CREATE'); fapl = H5P.create('H5P_FILE_ACCESS'); H5P.set_meta_block_size(fapl,4096); fid = H5F.create('myfile.h5','H5F_ACC_TRUNC',fcpl,fapl); H5F.close(fid);</pre>
See Also	<code>H5P.get_meta_block_size</code>

H5P.set_multi_type

Purpose Specify type of data accessed with MULTI driver

Syntax `H5P.set_multi_type(fapl_id,type)`

Description `H5P.set_multi_type(fapl_id,type)` sets the type of data property in the file access or data transfer property list `fapl_id`. The type argument can have any of the following values: `H5FD_MEM_SUPER`, `H5FD_MEM_BTREE`, `H5FD_MEM_DRAW`, `H5FD_MEM_GHEAP`, `H5FD_MEM_LHEAP`, or `H5FD_MEM_OHDR`.

See Also `H5P.get_multi_type`

Purpose Set maximum size of data sieve buffer

Syntax H5P.set_sieve_buf_size(fapl_id,buffer_size)

Description H5P.set_sieve_buf_size(fapl_id,buffer_size) sets buffer_size, the maximum size in bytes of the data sieve buffer, which is used by file drivers that are capable of using data sieving. fapl_id is a file access property list identifier.

Examples

```
fcpl = H5P.create('H5P_FILE_CREATE');
fapl = H5P.create('H5P_FILE_ACCESS');
H5P.set_sieve_buf_size(fapl,131072);
fid = H5F.create('myfile.h5','H5F_ACC_TRUNC',fcpl,fapl);
H5F.close(fid);
```

See Also H5P.get_sieve_buf_size

H5P.set_small_data_block_size

Purpose	Set size of block reserved for small data
Syntax	<code>H5P.set_small_data_block_size(fapl_id,size)</code>
Description	<code>H5P.set_small_data_block_size(fapl_id,size)</code> sets the maximum size, in bytes, of a contiguous block reserved for small data. <code>fapl_id</code> is a file access property list identifier.
Examples	<pre>fcpl = H5P.create('H5P_FILE_CREATE'); fapl = H5P.create('H5P_FILE_ACCESS'); H5P.set_small_data_block_size(fapl,4096); fid = H5F.create('myfile.h5','H5F_ACC_TRUNC',fcpl,fapl); H5F.close(fid);</pre>
See Also	<code>H5P.get_small_data_block_size</code>

Purpose Return 1/2 rank of indexed storage B-tree

Syntax `ik = H5P.get_istore_k(plist_id)`

Description `ik = H5P.get_istore_k(plist_id)` returns the chunked storage B-tree 1/2 rank of the file creation property list specified by `plist_id`.

Examples

```
fid = H5F.open('example.h5');
fcpl = H5F.get_create_plist(fid);
ik = H5P.get_istore_k(fcpl);
H5P.close(fcpl);
H5F.close(fid);
```

See Also `H5P.set_istore_k`

H5P.get_sizes

Purpose Return size of offsets and lengths

Syntax `[sizeof_addr,sizeof_size] = H5P.get_sizes(fcpl)`

Description `[sizeof_addr,sizeof_size] = H5P.get_sizes(fcpl)` returns the size of the offsets and lengths used in an HDF5 file. `fcpl` specifies a file creation property list.

Examples

```
fid = H5F.open('example.h5');
fcpl = H5F.get_create_plist(fid);
[soaddr, sosize] = H5P.get_sizes(fcpl);
H5P.close(fcpl);
H5F.close(fid);
```

See Also `H5P.set_sizes`

- Purpose** Return size of B-tree 1/2 rank and leaf node 1/2 size
- Syntax** `[ik, lk] = H5P.get_sym_k(plist_id)`
- Description** `[ik, lk] = H5P.get_sym_k(plist_id)` returns the size of the symbol table B-tree 1/2 rank, `ik`, and the symbol table leaf node 1/2 size, `lk`. The `plist_id` argument is a file creation property list identifier.
- Examples**
- ```
fid = H5F.open('example.h5');
fcpl = H5F.get_create_plist(fid);
[ik, lk] = H5P.get_sym_k(fcpl);
H5P.close(fcpl);
H5F.close(fid);
```
- See Also** `H5P.set_sym_k`

# H5P.get\_userblock

---

**Purpose** Return size of user block

**Syntax** `sz = H5P.get_userblock(plist_id)`

**Description** `sz = H5P.get_userblock(plist_id)` returns the size of a user block in a file creation property list. `plist_id` is a property list identifier.

**Examples**

```
fid = H5F.open('example.h5');
fcpl = H5F.get_create_plist(fid);
sz = H5P.get_userblock(fcpl);
H5P.close(fcpl);
H5F.close(fid);
```

**See Also** `H5P.set_userblock`

|                    |                                                                                                                                                                                                                                                             |
|--------------------|-------------------------------------------------------------------------------------------------------------------------------------------------------------------------------------------------------------------------------------------------------------|
| <b>Purpose</b>     | Return version information for file creation property list                                                                                                                                                                                                  |
| <b>Syntax</b>      | <code>[superblock, freelist, stab, shhdr] = H5P.get_version(fcpl)</code>                                                                                                                                                                                    |
| <b>Description</b> | <code>[superblock, freelist, stab, shhdr] = H5P.get_version(fcpl)</code> returns the version of the super block, the global freelist, the symbol table, and the shared object header. Retrieving this information requires the file creation property list. |
| <b>Examples</b>    | <pre>fid = H5F.open('example.h5'); fcpl = H5F.get_create_plist(fid); [super, freelist, stab, shhdr] = H5P.get_version(fcpl); H5P.close(fcpl); H5F.close(fid);</pre>                                                                                         |

# H5P.set\_istore\_k

---

**Purpose** Set size of parameter for indexing chunked datasets

**Syntax** `H5P.set_istore_k(plist_id, ik)`

**Description** `H5P.set_istore_k(plist_id, ik)` sets the size of the parameter used to control the B-trees for indexing chunked datasets for the file creation property list specified by `plist_id`. The `ik` argument is one half the rank of a tree that stores chunked raw data.

**Examples**

```
fcpl = H5P.create('H5P_FILE_CREATE');
fapl = H5P.create('H5P_FILE_ACCESS');
H5P.set_istore_k(fcpl, 64);
fid = H5F.create('myfile.h5', 'H5F_ACC_TRUNC', fcpl, fapl);
H5F.close(fid);
```

**See Also** `H5P.get_istore_k`



|                    |                                                                                                                                                                                                               |
|--------------------|---------------------------------------------------------------------------------------------------------------------------------------------------------------------------------------------------------------|
| <b>Purpose</b>     | Set byte size of offsets and lengths                                                                                                                                                                          |
| <b>Syntax</b>      | <code>H5P.set_sizes(plist_id, sizeof_addr, sizeof_size)</code>                                                                                                                                                |
| <b>Description</b> | <code>H5P.set_sizes(plist_id, sizeof_addr, sizeof_size)</code> sets the byte size of the offsets and lengths used to address objects in an HDF5 file. <code>plist_id</code> is a file creation property list. |
| <b>See Also</b>    | <code>H5P.get_sizes</code>                                                                                                                                                                                    |

# H5P.set\_sym\_k

---

**Purpose** Set size of parameters used to control symbol table nodes

**Syntax** `H5P.set_sym_k(plist_id, ik, lk)`

**Description** `H5P.set_sym_k(plist_id, ik, lk)` sets the size of parameters used to control the symbol table nodes for the file access property list, `plist_id`. The `ik` argument is one half the rank of a tree that stores a symbol table for a group. `lk` is one half of the number of symbols that can be stored in a symbol table node.

**Examples**

```
fcpl = H5P.create('H5P_FILE_CREATE');
fapl = H5P.create('H5P_FILE_ACCESS');
H5P.set_sym_k(fcpl, 32, 8);
fid = H5F.create('myfile.h5', 'H5F_ACC_TRUNC', fcpl, fapl);
H5F.close(fid);
```

**See Also** `H5P.get_sym_k`

|                    |                                                                                                                                                                                               |
|--------------------|-----------------------------------------------------------------------------------------------------------------------------------------------------------------------------------------------|
| <b>Purpose</b>     | Set user block size                                                                                                                                                                           |
| <b>Syntax</b>      | <code>H5P.set_userblock(plist_id,size)</code>                                                                                                                                                 |
| <b>Description</b> | <code>H5P.set_userblock(plist_id,size)</code> sets the user block size of the file creation property list, <code>plist_id</code> .                                                            |
| <b>Examples</b>    | <pre>fcpl = H5P.create('H5P_FILE_CREATE'); fapl = H5P.create('H5P_FILE_ACCESS'); H5P.set_userblock(fcpl,4096); fid = H5F.create('myfile.h5','H5F_ACC_TRUNC',fcpl,fapl); H5F.close(fid);</pre> |
| <b>See Also</b>    | <code>H5P.get_userblock</code>                                                                                                                                                                |

# H5P.get\_attr\_creation\_order

---

**Purpose** Return tracking order and indexing settings

**Syntax** `crt_order_flags = H5P.get_attr_phase_change(ocpl_id)`

**Description** `crt_order_flags = H5P.get_attr_phase_change(ocpl_id)` retrieves tracking and indexing settings for attribute creation order. If `crt_order_flags` is zero, then the attribute creation order is neither tracked or indexed. Otherwise the creation order flags should be one of the following constant values:

`H5P_CRT_ORDER_TRACKED`

`H5P_CRT_ORDER_INDEXED`

## Examples

```
fid = H5F.open('example.h5');
dset_id = H5D.open(fid, '/g3/integer');
dcpl = H5D.get_create_plist(dset_id);
flags = H5P.get_attr_creation_order(dcpl);
switch (flags)
 case 0
 fprintf('neither tracked nor indexed\n');
 case H5ML.get_constant_value('H5P_CRT_ORDER_TRACKED')
 fprintf('tracked\n');
 case H5ML.get_constant_value('H5P_CRT_ORDER_INDEXED')
 fprintf('indexed\n');
end
H5P.close(dcpl);
H5D.close(dset_id);
H5F.close(fid);
```

**See Also** `H5P.set_attr_creation_order` | `H5ML.get_constant_value`

|                    |                                                                                                                                                                                                                                                                                                                                                                                                                                             |
|--------------------|---------------------------------------------------------------------------------------------------------------------------------------------------------------------------------------------------------------------------------------------------------------------------------------------------------------------------------------------------------------------------------------------------------------------------------------------|
| <b>Purpose</b>     | Retrieve attribute phase change thresholds                                                                                                                                                                                                                                                                                                                                                                                                  |
| <b>Syntax</b>      | <code>[max_compact,min_dense] = H5P.get_attr_phase_change(ocpl_id)</code>                                                                                                                                                                                                                                                                                                                                                                   |
| <b>Description</b> | <p><code>[max_compact,min_dense] = H5P.get_attr_phase_change(ocpl_id)</code> retrieves attribute phase change thresholds for the dataset or group with creation property list <code>ocpl_id</code>.</p> <p><code>max_compact</code> is the maximum number of attributes to be stored in compact storage (default is 8).</p> <p><code>min_dense</code> is the minimum number of attributes to be stored in dense storage (default is 6).</p> |
| <b>Examples</b>    | <pre>fid = H5F.open('example.h5'); dset_id = H5D.open(fid,'/g3/integer'); dcpl = H5D.get_create_plist(dset_id); [max_compact,min_dense] = H5P.get_attr_phase_change(dcpl); H5P.close(dcpl); H5D.close(dset_id); H5F.close(fid);</pre>                                                                                                                                                                                                       |
| <b>See Also</b>    | <code>H5P.set_attr_phase_change</code>                                                                                                                                                                                                                                                                                                                                                                                                      |

# H5P.get\_copy\_object

---

|                    |                                                                                                                                                                                                                                    |
|--------------------|------------------------------------------------------------------------------------------------------------------------------------------------------------------------------------------------------------------------------------|
| <b>Purpose</b>     | Return properties to be used when object is copied                                                                                                                                                                                 |
| <b>Syntax</b>      | <code>copy_options = H5P.get_copy_object(ocpl_id)</code>                                                                                                                                                                           |
| <b>Description</b> | <code>copy_options = H5P.get_copy_object(ocpl_id)</code> retrieves the properties currently specified in the object copy property list <code>ocpl_id</code> , which will be invoked when a new copy is made of an existing object. |
| <b>Examples</b>    | <pre>ocpl = H5P.create('H5P_OBJECT_COPY'); options = H5P.get_copy_object(ocpl);</pre>                                                                                                                                              |
| <b>See Also</b>    | <code>H5P.set_copy_object</code>                                                                                                                                                                                                   |

|                    |                                                                                                                                                                                                                                                                                                                                                                                                         |
|--------------------|---------------------------------------------------------------------------------------------------------------------------------------------------------------------------------------------------------------------------------------------------------------------------------------------------------------------------------------------------------------------------------------------------------|
| <b>Purpose</b>     | Set tracking of attribute creation order                                                                                                                                                                                                                                                                                                                                                                |
| <b>Syntax</b>      | <code>H5P.set_attr_creation_order(gcplId,crt_order_flags)</code>                                                                                                                                                                                                                                                                                                                                        |
| <b>Description</b> | <p><code>H5P.set_attr_creation_order(gcplId,crt_order_flags)</code> sets tracking and indexing of attribute creation order. The creation order flags should be either <code>H5P_CRT_ORDER_TRACKED</code> or a bitwise-or of <code>H5P_CRT_ORDER_TRACKED</code> and <code>H5P_CRT_ORDER_INDEXED</code>.</p> <p>The default behavior is that attribute creation order is neither tracked nor indexed.</p> |
| <b>Examples</b>    | <pre>dcpl = H5P.create('H5P_DATASET_CREATE'); order = H5ML.get_constant_value('H5P_CRT_ORDER_TRACKED'); H5P.set_attr_creation_order(dcpl,order);</pre>                                                                                                                                                                                                                                                  |
| <b>See Also</b>    | <code>H5P.get_attr_creation_order</code>   <code>H5ML.get_constant_value</code>   <code>bitor</code>                                                                                                                                                                                                                                                                                                    |

# H5P.set\_attr\_phase\_change

---

**Purpose** Set attribute storage phase change thresholds

**Syntax** `H5P.get_attr_phase_change(ocpl_id,max_compact,min_dense)`

**Description** `H5P.get_attr_phase_change(ocpl_id,max_compact,min_dense)` sets attribute storage phase change thresholds for the group or dataset with creation order property list `ocpl_id`.

`max_compact` is the maximum number of attributes to be stored in compact storage (default is 8).

`min_dense` is the minimum number of attributes to be stored in dense storage (default is 6).

**See Also** `H5P.get_attr_phase_change`



**Purpose**

Set properties to be used when objects are copied

**Syntax**

`H5P.set_copy_object(ocp_plist_id,copy_options)`

**Description**

`H5P.set_copy_object(ocp_plist_id,copy_options)` sets the properties in the object copy property list `ocp_plist_id` that will be invoked when a new copy is made of an existing object. `ocp_plist_id` is the object copy property list and specifies the properties governing the copying of the object.

Several flags, described below, are available for inclusion in the object copy property list:

**H50\_COPY\_SHALLOW\_HIERARCHY\_FLAG** Copy only immediate members of a group. Default behavior, without flag: Recursively copy all objects below the group.

**H50\_COPY\_EXPAND\_SOFT\_LINK\_FLAG** Expand soft links into new objects. Default behavior, without flag: Keep soft links as they are.

**H50\_COPY\_EXPAND\_EXT\_LINK\_FLAG** Expand external link into new objects. Default behavior, without flag: Keep external links as they are.

**H50\_COPY\_EXPAND\_REFERENCE\_FLAG** Copy objects that are pointed to by references. Default behavior, without flag: Update only the values of object references.

**H50\_COPY\_WITHOUT\_ATTR\_FLAG** Copy object without copying attributes. Default behavior, without flag: Copy object along with all its attributes.

# H5P.set\_copy\_object

---

## Examples

```
ocp_plist_id = H5P.create ('H5P_OBJECT_COPY');
option1 = H5ML.get_constant_value('H5O_COPY_EXPAND_SOFT_LINK_FLAG');
option2 = H5ML.get_constant_value('H5O_COPY_EXPAND_REFERENCE_FLAG');
copy_options = bitor(option1,option2);
H5P.set_copy_object(ocp_plist_id, copy_options);
```

# H5P.get\_create\_intermediate\_group

---

|                    |                                                                                                                                                                                                                                    |
|--------------------|------------------------------------------------------------------------------------------------------------------------------------------------------------------------------------------------------------------------------------|
| <b>Purpose</b>     | Determine creation of intermediate groups                                                                                                                                                                                          |
| <b>Syntax</b>      | <code>bool = H5P.get_create_intermediate_group(lcpl_id)</code>                                                                                                                                                                     |
| <b>Description</b> | <code>bool = H5P.get_create_intermediate_group(lcpl_id)</code> determines whether the link creation property list <code>lcpl_id</code> is set to enable creating missing intermediate groups.                                      |
| <b>Examples</b>    | <pre>lcpl = H5P.create('H5P_LINK_CREATE'); if H5P.get_create_intermediate_group(lcpl)     fprintf('set to enable creating intermediate groups\n'); else     fprintf('not set to enable creating intermediate groups\n'); end</pre> |
| <b>See Also</b>    | <code>H5P.set_create_intermediate_group</code>                                                                                                                                                                                     |

# H5P.get\_link\_creation\_order

---

**Purpose** Query if link creation order is tracked

**Syntax** `crt_order_flags = H5P.get_link_phase_change(gcpl_id)`

**Description** `crt_order_flags = H5P.get_link_phase_change(gcpl_id)` queries whether link creation order is tracked or indexed in a group with creation property list identifier `gcpl_id`. The creation order flags should be one of the following constant values:

`H5P_CRT_ORDER_TRACKED`

`H5P_CRT_ORDER_INDEXED`

**Examples**

```
tracked = H5ML.get_constant_value('H5P_CRT_ORDER_TRACKED');
indexed = H5ML.get_constant_value('H5P_CRT_ORDER_INDEXED');
gcpl = H5P.create('H5P_GROUP_CREATE');
order = H5P.get_link_creation_order(gcpl);
if bitand(order,tracked)
 fprintf('order is tracked\n');
end
if bitand(order,indexed)
 fprintf('order is indexed\n');
end
```

**See Also** `H5P.set_link_creation_order` | `H5ML.get_constant_value` | `bitand`

|                    |                                                                                                                                                                                                                                                                                                                                                                                                                                                                                                                                                                                                                                                                                              |
|--------------------|----------------------------------------------------------------------------------------------------------------------------------------------------------------------------------------------------------------------------------------------------------------------------------------------------------------------------------------------------------------------------------------------------------------------------------------------------------------------------------------------------------------------------------------------------------------------------------------------------------------------------------------------------------------------------------------------|
| <b>Purpose</b>     | Query settings for conversion between groups                                                                                                                                                                                                                                                                                                                                                                                                                                                                                                                                                                                                                                                 |
| <b>Syntax</b>      | <code>[max_compact,min_dense] = H5P.get_link_phase_change(gcpl_id)</code>                                                                                                                                                                                                                                                                                                                                                                                                                                                                                                                                                                                                                    |
| <b>Description</b> | <p><code>[max_compact,min_dense] = H5P.get_link_phase_change(gcpl_id)</code> retrieves the settings for conversion between compact and dense groups.</p> <p><code>max_compact</code> is the maximum number of links to store as header messages in the group header before converting the group to the dense format. Groups that are in the compact format and exceed this number of links are automatically converted to the dense format.</p> <p><code>min_dense</code> is the minimum number of links to store in the dense format. Groups which are in dense format and in which the number of links falls below this number are automatically converted back to the compact format.</p> |
| <b>Examples</b>    | <pre>gcpl = H5P.create('H5P_GROUP_CREATE');<br/>[max_compact, min_dense] = H5P.get_link_phase_change(gcpl);</pre>                                                                                                                                                                                                                                                                                                                                                                                                                                                                                                                                                                            |
| <b>See Also</b>    | <code>H5P.set_link_phase_change</code>                                                                                                                                                                                                                                                                                                                                                                                                                                                                                                                                                                                                                                                       |

# H5P.set\_create\_intermediate\_group

---

**Purpose** Set creation of intermediate groups

**Syntax** H5P.set\_create\_intermediate\_group(lcpl\_id,flag)

**Description** H5P.set\_create\_intermediate\_group(lcpl\_id,flag) specifies in the link creation property list lcpl\_id whether to create missing intermediate groups.

**Examples** Enable the creation of intermediate groups.

```
fid = H5F.create('myfile.h5');
lcpl = H5P.create('H5P_LINK_CREATE');
H5P.set_create_intermediate_group(lcpl,1);
gid = H5G.create(fid,'/a/b/c/d',lcpl,'H5P_DEFAULT','H5P_DEFAULT');
H5G.close(gid);
H5F.close(fid);
```

**See Also** H5P.get\_create\_intermediate\_group

|                    |                                                                                                                                                                                                                                                                                                                                                                                                                                                                                                                                                                                                                                                                                                                                |
|--------------------|--------------------------------------------------------------------------------------------------------------------------------------------------------------------------------------------------------------------------------------------------------------------------------------------------------------------------------------------------------------------------------------------------------------------------------------------------------------------------------------------------------------------------------------------------------------------------------------------------------------------------------------------------------------------------------------------------------------------------------|
| <b>Purpose</b>     | Set creation order tracking and indexing                                                                                                                                                                                                                                                                                                                                                                                                                                                                                                                                                                                                                                                                                       |
| <b>Syntax</b>      | <code>H5P.set_link_creation_order(gcplId,crt_order_flags)</code>                                                                                                                                                                                                                                                                                                                                                                                                                                                                                                                                                                                                                                                               |
| <b>Description</b> | <p><code>H5P.set_link_creation_order(gcplId,crt_order_flags)</code> sets creation order tracking and indexing for links in the group with group creation property list <code>gcpl_id</code>.</p> <p>The creation order flags should be one of the following constant values:</p> <p><code>H5P_CRT_ORDER_TRACKED</code><br/><code>H5P_CRT_ORDER_INDEXED</code></p> <p>If only <code>H5P_CRT_ORDER_TRACKED</code> is set, HDF5 will track link creation order in any group created with the group creation property list <code>gcpl_id</code>. If both <code>H5P_CRT_ORDER_TRACKED</code> and <code>H5P_CRT_ORDER_INDEXED</code> are set, HDF5 will track link creation order in the group and index links on that property.</p> |
| <b>Examples</b>    | <pre>tracked = H5ML.get_constant_value('H5P_CRT_ORDER_TRACKED'); indexed = H5ML.get_constant_value('H5P_CRT_ORDER_INDEXED'); order = bitor(tracked,indexed); gcpl = H5P.create('H5P_GROUP_CREATE'); H5P.set_link_creation_order(gcpl,order);</pre>                                                                                                                                                                                                                                                                                                                                                                                                                                                                             |
| <b>See Also</b>    | <code>H5P.get_link_creation_order</code>   <code>H5ML.get_constant_value</code>                                                                                                                                                                                                                                                                                                                                                                                                                                                                                                                                                                                                                                                |

# H5P.set\_link\_phase\_change

---

|                    |                                                                                                                                                                                                                                                                                                                                                                                                                                                                                                                                                                                                                                                                                       |
|--------------------|---------------------------------------------------------------------------------------------------------------------------------------------------------------------------------------------------------------------------------------------------------------------------------------------------------------------------------------------------------------------------------------------------------------------------------------------------------------------------------------------------------------------------------------------------------------------------------------------------------------------------------------------------------------------------------------|
| <b>Purpose</b>     | Set parameters for group conversion                                                                                                                                                                                                                                                                                                                                                                                                                                                                                                                                                                                                                                                   |
| <b>Syntax</b>      | <code>H5P.get_link_phase_change(gcpl_id,max_compact,min_dense)</code>                                                                                                                                                                                                                                                                                                                                                                                                                                                                                                                                                                                                                 |
| <b>Description</b> | <p><code>H5P.get_link_phase_change(gcpl_id,max_compact,min_dense)</code> sets the parameters for conversion between compact and dense groups.</p> <p><code>max_compact</code> is the maximum number of links to store as header messages in the group header before converting the group to the dense format. Groups that are in the compact format and exceed this number of links are automatically converted to the dense format.</p> <p><code>min_dense</code> is the minimum number of links to store in the dense format. Groups which are in dense format and in which the number of links falls below this number are automatically converted back to the compact format.</p> |
| <b>Examples</b>    | <pre>gcpl = H5P.create('H5P_GROUP_CREATE'); H5P.set_link_phase_change(gcpl,10,8);</pre>                                                                                                                                                                                                                                                                                                                                                                                                                                                                                                                                                                                               |
| <b>See Also</b>    | <code>H5P.get_link_phase_change</code>                                                                                                                                                                                                                                                                                                                                                                                                                                                                                                                                                                                                                                                |



**Purpose** Return character encoding

**Syntax** `encoding = H5P.get_char_encoding(propertyList)`

**Description** `encoding = H5P.get_char_encoding(propertyList)` retrieves the character encoding used to encode strings or object names that are created with the property list `propertyList`. The values returned correspond to either `H5T_CSET_ASCII` or `H5T_CSET_UTF8`.

**See Also** `H5P.set_char_encoding` | `H5ML.get_constant_value`

# H5P.set\_char\_encoding

---

|                    |                                                                                                                                                                                                                                                                                              |
|--------------------|----------------------------------------------------------------------------------------------------------------------------------------------------------------------------------------------------------------------------------------------------------------------------------------------|
| <b>Purpose</b>     | Set character encoding used to encode strings                                                                                                                                                                                                                                                |
| <b>Syntax</b>      | <code>H5P.set_char_encoding(propList,encoding)</code>                                                                                                                                                                                                                                        |
| <b>Description</b> | <code>H5P.set_char_encoding(propList,encoding)</code> sets the character encoding used to encode strings or object names that are created with the property list <code>propList</code> . The values of encoding should either be <code>H5T_CSET_ASCII</code> or <code>H5T_CSET_UTF8</code> . |
| <b>See Also</b>    | <code>H5P.get_char_encoding</code>   <code>H5ML.get_constant_value</code>                                                                                                                                                                                                                    |

**Purpose**

Create reference

**Syntax**

```
ref = H5R.create(loc_id,name,ref_type,space_id)
```

**Description**

`ref = H5R.create(loc_id,name,ref_type,space_id)` creates the reference, `ref`, of the type specified in `ref_type`, pointing to the object specified by name located at `loc_id`. The `ref_type` argument can be either 'H5R\_OBJECT', or 'H5R\_DATASET\_REGION'. The `space_id` argument should be -1, if `ref_type` is 'H5R\_OBJECT'.

**Examples**

Create a double-precision dataset and a reference dataset.

```
fid = H5F.create('myfile.h5');
type1_id = H5T.copy('H5T_NATIVE_DOUBLE');
dims = [10 5];
h5_dims = flip1r(dims);
h5_maxdims = h5_dims;
space1_id = H5S.create_simple(2,h5_dims,h5_maxdims);
dcpl = 'H5P_DEFAULT';
dset1_id = H5D.create(fid,'my_double',type1_id,space1_id,dcpl);
type2_id = 'H5T_STD_REF_OBJ';
space2_id = H5S.create('H5S_SCALAR');
dset2_id = H5D.create(fid,'my_ref',type2_id,space2_id,dcpl);
ref_data = H5R.create(fid,'my_double','H5R_OBJECT',-1);
dxpl = 'H5P_DEFAULT';
H5D.write(dset2_id,'H5ML_DEFAULT','H5S_ALL','H5S_ALL',dxpl,ref_data);
H5D.close(dset1_id);
H5D.close(dset2_id);
H5F.close(fid);
```

**See Also**

H5D.create

# H5R.dereference

---

**Purpose** Open object specified by reference

**Syntax** `output = H5R.dereference(dataset,ref_type,ref)`

**Description** `output = H5R.dereference(dataset,ref_type,ref)` returns an identifier to the object specified by `ref` in the dataset specified by `dataset`.

**Examples**

```
plist = 'H5P_DEFAULT';
space = 'H5S_ALL';
fid = H5F.open('example.h5');
dset_id = H5D.open(fid,'/g3/reference');
ref_data = H5D.read(dset_id,'H5T_STD_REF_OBJ',space,space,plist);
deref_dset_id = H5R.dereference(dset_id,'H5R_OBJECT',ref_data(:,1));
H5D.close(dset_id);
H5D.close(deref_dset_id);
H5F.close(fid);
```

**See Also** `H5R.create` | `H5I.get_name`

**Purpose** Name of referenced object

**Syntax** `name = H5R.get_name(loc_id,ref_type,ref)`

**Description** `name = H5R.get_name(loc_id,ref_type,ref)` retrieves the name for the object identified by `ref`. The `loc_id` argument is the identifier for the dataset containing the reference or for the group containing that dataset. `ref_type` specifies the type of the reference `ref`. Valid values for `ref_type` are 'H5R\_OBJECT' or 'H5R\_DATASET\_REGION'.

**Examples**

```
plist = 'H5P_DEFAULT';
space = 'H5S_ALL';
fid = H5F.open('example.h5');
dset_id = H5D.open(fid, '/g3/reference');
ref_data = H5D.read(dset_id, 'H5T_STD_REF_OBJ', space, space, plist);
name = H5R.get_name(dset_id, 'H5R_OBJECT', ref_data(:,1));
H5D.close(dset_id);
H5F.close(fid);
```

**See Also** `H5I.get_name`

# H5R.get\_obj\_type

---

**Purpose** Type of referenced object

**Syntax** `obj_type = H5R.get_obj_type(id,ref_type,ref)`

**Description** `obj_type = H5R.get_obj_type(id,ref_type,ref)` returns the type of object that an object reference points to. Valid values for `ref_type` are: `H5R_OBJECT` or `H5R_DATASET_REGION`. Valid return values correspond to the following values.

|                           |                             |
|---------------------------|-----------------------------|
| 'H5O_TYPE_GROUP'          | Object is a group.          |
| 'H5O_TYPE_DATASET'        | Object is a dataset.        |
| 'H5O_TYPE_NAMED_DATATYPE' | Object is a named datatype. |

This function corresponds to the 1.8 interface version of `H5Rget_obj_type` in the HDF5 library C API.

## Examples

```
plist = 'H5P_DEFAULT';
space = 'H5S_ALL';
fid = H5F.open('example.h5');
dset_id = H5D.open(fid, '/g3/reference');
ref_data = H5D.read(dset_id, 'H5T_STD_REF_OBJ', space, space, plist);
obj_type = H5R.get_obj_type(fid, 'H5R_OBJECT', ref_data(:,1));
switch(obj_type)
 case H5ML.get_constant_value('H5O_TYPE_GROUP')
 fprintf('group\n');
 case H5ML.get_constant_value('H5O_TYPE_DATASET')
 fprintf('dataset\n');
 case H5ML.get_constant_value('H5O_TYPE_NAMED_DATATYPE')
 fprintf('named datatype\n');
end
H5D.close(dset_id);
H5F.close(fid);
```

**See Also** `H5ML.get_constant_value`

**Purpose** Copy of data space of specified region

**Syntax** `space_id = H5R.get_region(dataset,ref_type,ref)`

**Description** `space_id = H5R.get_region(dataset,ref_type,ref)` returns a data space with the specified region selected. `dataset` is used to identify the file containing the referenced region and can be any identifier for any object in the file.

**Examples**

```
space = 'H5S_ALL';
plist = 'H5P_DEFAULT';
fid = H5F.open('example.h5');
dset_id = H5D.open(fid,'/g3/region_reference');
ref_data = H5D.read(dset_id,'H5T_STD_REF_DSETREG',space,space,plist);
space_id = H5R.get_region(fid,'H5R_DATASET_REGION',ref_data(:,1));
H5S.close(space_id);
H5D.close(dset_id);
H5F.close(fid);
```

# H5S.copy

---

**Purpose** Create copy of data space

**Syntax** `output = H5S.copy(space_id)`

**Description** `output = H5S.copy(space_id)` creates a new data space, which is an exact copy of the dataspace identified by `space_id`. The output argument is a data space identifier.

**Examples**

```
fid = H5F.open('example.h5');
dset_id = H5D.open(fid, '/g2/dset2.1');
space1_id = H5D.get_space(dset_id);
space2_id = H5S.copy(space1_id);
[~,dims1] = H5S.get_simple_extent_dims(space1_id)
[~,dims2] = H5S.get_simple_extent_dims(space2_id)
```

**See Also** `H5D.get_space` | `H5S.get_simple_extent_dims`



**Purpose** Create new data space

**Syntax** `space_id = H5S.create(space_type)`

**Description** `space_id = H5S.create(space_type)` creates a new dataspace of the type specified by `space_type`, which can be specified by one of the following strings.

`'H5S_SCALAR'`

`'H5S_SIMPLE'`

`'H5S_NULL'`

`space_id` is the identifier for the new dataspace.

**Examples** Create a scalar dataspace.

```
space_id = H5S.create('H5S_SCALAR');
numpoints = H5S.get_simple_extent_npoints(space_id);
```

**See Also** `H5S.get_simple_extent_npoints`

# H5S.close

---

**Purpose** Close data space

**Syntax** `H5S.close(space_id)`

**Description** `H5S.close(space_id)` releases and terminates access to a data space. `space_id` is a data space identifier.

**See Also** `H5A.get_space` | `H5D.get_space`

**Purpose** Create new simple data space

**Syntax** `space_id = H5S.create_simple(rank,h5_dims,h5_maxdims)`

**Description** `space_id = H5S.create_simple(rank,h5_dims,h5_maxdims)` creates a new simple data space and opens it for access. `rank` is the number of dimensions used in the data space. `h5_dims` is an array specifying the size of each dimension of the dataset. `h5_maxdims` is an array specifying the upper limit on the size of each dimension. `space_id` is a data space identifier.

---

**Note** The HDF5 library uses C-style ordering for multidimensional arrays, while MATLAB uses FORTRAN-style ordering. The `h5_dims` and `h5_maxdims` parameters assume C-style ordering. Please consult "Using the MATLAB Low-Level HDF5 Functions" in the MATLAB documentation for more information.

---

**Examples** Create a data space for a dataset with 10 rows and 5 columns.

```
dims = [10 5];
h5_dims = flip1r(dims);
h5_maxdims = h5_dims;
space_id = H5S.create_simple(2,h5_dims,h5_maxdims);
```

---

Create a data space for a dataset with 10 rows and 5 columns such that the dataset is extendible along the column dimension.

```
dims = [10 5];
h5_dims = flip1r(dims);
maxdims = [10 H5ML.get_constant_value('H5S_UNLIMITED')];
h5_maxdims = flip1r(maxdims);
space_id = H5S.create_simple(2,h5_dims,h5_maxdims);
```

# H5S.create\_simple

---

## See Also

[H5S.create](#) | [H5S.close](#) | [H5ML.get\\_constant\\_value](#)

|                    |                                                                                                                                                                                                                                                                                                                       |
|--------------------|-----------------------------------------------------------------------------------------------------------------------------------------------------------------------------------------------------------------------------------------------------------------------------------------------------------------------|
| <b>Purpose</b>     | Copy extent from source to destination data space                                                                                                                                                                                                                                                                     |
| <b>Syntax</b>      | <code>H5S.extent_copy(dst_id,src_id)</code>                                                                                                                                                                                                                                                                           |
| <b>Description</b> | <code>H5S.extent_copy(dst_id,src_id)</code> copies the extent from the source data space, <code>src_id</code> , to the destination data space, <code>dst_id</code> .                                                                                                                                                  |
| <b>Examples</b>    | <pre>space_id1 = H5S.create('H5S_SIMPLE'); dims = [100 200]; h5_dims = fliplr(dims); maxdims = [100 H5ML.get_constant_value('H5S_UNLIMITED')]; h5_maxdims = fliplr(maxdims); H5S.set_extent_simple(space_id1,2,h5_dims,h5_maxdims); space_id2 = H5S.create('H5S_SIMPLE'); H5S.extent_copy(space_id2,space_id1);</pre> |
| <b>See Also</b>    | <code>H5S.create</code>   <code>H5S.get_simple_extent_dims</code>  <br><code>H5S.set_extent_simple</code>                                                                                                                                                                                                             |

# H5S.get\_select\_bounds

---

**Purpose** Bounding box of data space selection

**Syntax** `[start,finish] = H5S.get_select_bounds(space_id)`

**Description** `[start,finish] = H5S.get_select_bounds(space_id)` returns the coordinates of the bounding box containing the current selection. `start` contains the starting coordinates of the bounding box and `finish` contains the coordinates of the diagonally opposite corner.

---

**Note** The HDF5 library uses C-style ordering for multidimensional arrays, while MATLAB uses FORTRAN-style ordering. The `h5_start`, `h5_stride`, `h5_count` and `h5_block` parameters assume C-style ordering. Please consult "Using the MATLAB Low-Level HDF5 Functions" in the MATLAB documentation for more information.

---

## Examples

```
dims = [100 200];
h5_dims = fliplr(dims);
space_id = H5S.create_simple(2,h5_dims,h5_dims);
start = fliplr([10 20]); block = fliplr([20 30]);
H5S.select_hyperslab(space_id,'H5S_SELECT_SET',start,[],[],block);
start = fliplr([30 40]); block = fliplr([20 30]);
H5S.select_hyperslab(space_id,'H5S_SELECT_OR',start,[],[],block);
[start, finish] = H5S.get_select_bounds(space_id);
matlab_start = fliplr(start);
matlab_finish = fliplr(finish);
```

## See Also

`H5S.create_simple` | `H5S.select_hyperslab`

**Purpose** Number of element points in selection

**Syntax** `numpoints = H5S.get_select_elem_npoints(space_id)`

**Description** `numpoints = H5S.get_select_elem_npoints(space_id)` returns the number of element points in the current data space selection.

**Examples** Select the corner points of a data space.

```
dims = [100 200];
h5_dims = fliplr(dims);
space_id = H5S.create_simple(2,h5_dims,h5_dims);
coords = [0 0; 0 199; 99 0; 99 199];
coords = fliplr(coords);
coords = coords';
H5S.select_elements(space_id,'H5S_SELECT_SET',coords)
numpoints = H5S.get_select_elem_npoints(space_id);
```

**See Also** `H5S.select_elements`

# H5S.get\_select\_elem\_pointlist

---

|                    |                                                                                                                                                                                                                                                                                                                                                                                                                                                                                                                                                |
|--------------------|------------------------------------------------------------------------------------------------------------------------------------------------------------------------------------------------------------------------------------------------------------------------------------------------------------------------------------------------------------------------------------------------------------------------------------------------------------------------------------------------------------------------------------------------|
| <b>Purpose</b>     | Element points in data space selection                                                                                                                                                                                                                                                                                                                                                                                                                                                                                                         |
| <b>Syntax</b>      | <code>points = H5S.get_select_elem_pointlist(space_id,startpoint,numpoints)</code>                                                                                                                                                                                                                                                                                                                                                                                                                                                             |
| <b>Description</b> | <p><code>points = H5S.get_select_elem_pointlist(space_id,startpoint,numpoints)</code> returns the list of element points in the current data space selection. <code>startpoint</code> specifies the element point to start with and <code>numpoints</code> specifies the total number of points.</p> <p><code>points</code> is a two-dimensional array of 0-based values specifying the coordinates of the elements. If <code>m</code> is the rank of the dataspace, then <code>points</code> will have size <code>[m x numpoints]</code>.</p> |

---

**Note** The ordering of the coordinate points is the same as the HDF5 library C API.

---

**Examples** Determine the first two points in the current selection.

```
dims = [100 200];
h5_dims = fliplr(dims);
space_id = H5S.create_simple(2,h5_dims,h5_dims);
coords = [0 0; 0 199; 99 0; 99 199];
coords = fliplr(coords);
coords = coords';
H5S.select_elements(space_id,'H5S_SELECT_SET',coords);
points = H5S.get_select_elem_pointlist(space_id,0,2);
```



**Purpose** List of hyperslab blocks

**Syntax** `blocklist = H5S.get_select_hyper_blocklist(space_id,startblock, numblocks)`

**Description** `blocklist = H5S.get_select_hyper_blocklist(space_id,startblock, numblocks)` returns a list of the hyperslab blocks currently selected. `space_id` is a dataspace identifier. `startblock` specifies the block to start with and `numblocks` specifies the number of hyperslab blocks to retrieve.

---

**Note** The HDF5 library uses C-style ordering for multidimensional arrays, while MATLAB uses FORTRAN-style ordering. The `h5_start`, `h5_stride`, `h5_count` and `h5_block` parameters assume C-style ordering. Please consult "Using the MATLAB Low-Level HDF5 Functions" in the MATLAB documentation for more information.

---

**Examples**

```
dims = [100 200];
h5_dims = fliplr(dims);
space_id = H5S.create_simple(2,h5_dims,h5_dims);
start = fliplr([10 20]); block = fliplr([20 25]);
H5S.select_hyperslab(space_id,'H5S_SELECT_SET',start,[],[],block);
start = fliplr([20 30]); block = fliplr([20 25]);
H5S.select_hyperslab(space_id,'H5S_SELECT_NOTB',start,[],[],block);
numblocks = H5S.get_select_hyper_nblocks(space_id);
for j = 1:numblocks
 hblocks{j} = H5S.get_select_hyper_blocklist(space_id,j-1,1);
end
```

**See Also** `H5S.select_hyperslab` | `H5S.get_select_hyper_nblocks`

# H5S.get\_select\_hyper\_nblocks

---

**Purpose** Number of hyperslab blocks

**Syntax** `num_blocks = H5S.get_select_hyper_nblocks(space_id)`

**Description** `num_blocks = H5S.get_select_hyper_nblocks(space_id)` returns the number of hyperslab blocks in the current data space selection.

**Examples**

```
dims = [100 200];
h5_dims = fliplr(dims);
space_id = H5S.create_simple(2,h5_dims,h5_dims);
start = fliplr([10 20]); block = fliplr([20 25]);
H5S.select_hyperslab(space_id,'H5S_SELECT_SET',start,[],[],block);
start = fliplr([20 30]); block = fliplr([20 25]);
H5S.select_hyperslab(space_id,'H5S_SELECT_NOTB',start,[],[],block);
nblocks = H5S.get_select_hyper_nblocks(space_id);
```

**See Also** `H5S.get_select_hyper_blocklist` | `H5S.select_hyperslab`

**Purpose** Number of elements in data space selection

**Syntax** `num_points = H5S.get_select_npoints(space_id)`

**Description** `num_points = H5S.get_select_npoints(space_id)` returns the number of elements in the current data space selection.

**Examples**

```
dims = [100 200];
h5_dims = fliplr(dims);
space_id = H5S.create_simple(2,h5_dims,h5_dims);
op = 'H5S_SELECT_SET';
start = fliplr([10 20]); block = fliplr([20 30]);
H5S.select_hyperslab(space_id,'H5S_SELECT_SET',start,[],[],block);
n = H5S.get_select_npoints(space_id);
```

**See Also** `H5S.create_simple` | `H5S.select_hyperslab`

# H5S.get\_select\_type

---

**Purpose** Type of data space selection

**Syntax** `sel_type = H5S.get_select_type(space_id)`

**Description** `sel_type = H5S.get_select_type(space_id)` returns the data space selection type. Valid return values correspond to the following enumerated constants:

```
H5S_SEL_NONE
H5S_SEL_POINTS
H5S_SEL_HYPERSLABS
H5S_SEL_ALL
```

**Examples**

```
dims = [100 200];
h5_dims = flip1r(dims);
space_id = H5S.create_simple(2,h5_dims,h5_dims);
start = flip1r([10 20]); block = flip1r([20 30]);
H5S.select_hyperslab(space_id,'H5S_SELECT_SET',start,[],[],block);
sel_type = H5S.get_select_type(space_id);
switch(sel_type)
 case H5ML.get_constant_value('H5S_SEL_NONE')
 fprintf('no selection\n');
 case H5ML.get_constant_value('H5S_SEL_POINTS');
 fprintf('point selection\n');
 case H5ML.get_constant_value('H5S_SEL_HYPERSLABS');
 fprintf('hyperslab selection\n');
end
```

**See Also** `H5S.select_elements` | `H5S.select_hyperslab` | `H5ML.get_constant_value`

|                    |                                                                                                                                                                                                          |
|--------------------|----------------------------------------------------------------------------------------------------------------------------------------------------------------------------------------------------------|
| <b>Purpose</b>     | Data space size and maximum size                                                                                                                                                                         |
| <b>Syntax</b>      | <code>[numdims,h5_dims,h5_maxdims] = H5S.get_simple_extent_dims(space_id)</code>                                                                                                                         |
| <b>Description</b> | <code>[numdims,h5_dims,h5_maxdims] = H5S.get_simple_extent_dims(space_id)</code> returns the number of dimensions in the data space, the size of each dimension, and the maximum size of each dimension. |

---

**Note** The HDF5 library uses C-style ordering for multidimensional arrays, while MATLAB uses FORTRAN-style ordering. The `h5_dims` and `h5_maxdims` assume C-style ordering. Please consult "Using the MATLAB Low-Level HDF5 Functions" in the MATLAB documentation for more information.

---

**Examples**

```
fid = H5F.open('example.h5');
dset_id = H5D.open(fid,'/g2/dset2.2');
space_id = H5D.get_space(dset_id);
[numdims,h5_dims] = H5S.get_simple_extent_dims(space_id);
matlab_dims = fliplr(h5_dims);
```

# H5S.get\_simple\_extent\_ndims

---

**Purpose** Data space rank

**Syntax** `output = H5S.get_simple_extent_ndims(space_id)`

**Description** `output = H5S.get_simple_extent_ndims(space_id)` returns the dimensionality (also called the rank) of a data space.

# H5S.get\_simple\_extent\_npoints

---

**Purpose**

Number of elements in data space

**Syntax**

```
output = H5S.get_simple_extent_npoints(space_id)
```

**Description**

`output = H5S.get_simple_extent_npoints(space_id)` returns the number of elements in the data space specified by `space_id`.

# H5S.get\_simple\_extent\_type

---

**Purpose** Data space class

**Syntax** `space_type = H5S.get_simple_extent_type(space_id)`

**Description** `space_type = H5S.get_simple_extent_type(space_id)` returns the data space class of the data space specified by `space_id`.

**Examples**

```
fid = H5F.open('example.h5');
dset_id = H5D.open(fid, '/g3/integer');
space_id = H5D.get_space(dset_id);
space_type = H5S.get_simple_extent_type(space_id);
switch(space_type)
 case H5ML.get_constant_value('H5S_SCALAR')
 fprintf('scalar\n');
 case H5ML.get_constant_value('H5S_SIMPLE')
 fprintf('simple\n');
 case H5ML.get_constant_value('H5S_NULL')
 fprintf('none\n');
end
```

**See Also** `H5S.create` | `H5D.get_space` | `H5ML.get_constant_value`



**Purpose** Determine if data space is simple

**Syntax** `output = H5S.is_simple(space_id)`

**Description** `output = H5S.is_simple(space_id)` returns a positive value if the data space specified by `space_id` is a simple data space, zero if it is not, and a negative value to indicate failure.

**Examples** Create a new data space and verify that it is simple.

```
dims = [100 200];
h5_dims = fliplr(dims);
space_id = H5S.create_simple(2,h5_dims,h5_dims);
val = H5S.is_simple(space_id);
```

---

Create a null data space and verify that it is not simple.

```
space_id = H5S.create('H5S_NULL');
val = H5S.is_simple(space_id);
```

**See Also** `H5S.create` | `H5S.create_simple`

# H5S.offset\_simple

---

**Purpose** Set offset of simple data space

**Syntax** H5S.offset\_simple(space\_id,offset)

**Description** H5S.offset\_simple(space\_id,offset) specifies the offset of the simple data space specified by space\_id. This function allows the same shaped selection to be moved to different locations within a data space without requiring it to be redefined.

---

**Note** The HDF5 library uses C-style ordering for multidimensional arrays, while MATLAB uses FORTRAN-style ordering. The h5\_start, h5\_stride, h5\_count and h5\_block parameters assume C-style ordering. Please consult "Using the MATLAB Low-Level HDF5 Functions" in the MATLAB documentation for more information.

---

## Examples

```
dims = [100 200];
h5_dims = fliplr(dims);
space_id = H5S.create_simple(2,h5_dims,h5_dims);
start = fliplr([10 20]); block = fliplr([20 30]);
H5S.select_hyperslab(space_id,'H5S_SELECT_SET',start,[],[],block);
offset = fliplr([3 5]);
H5S.offset_simple(space_id,offset)
[start,finish] = H5S.get_select_bounds(space_id);
start = fliplr(start);
finish = fliplr(finish);
```

## See Also

H5S.get\_select\_bounds | H5S.select\_hyperslab

|                    |                                                                                                                                                                                                                                                                                                                          |
|--------------------|--------------------------------------------------------------------------------------------------------------------------------------------------------------------------------------------------------------------------------------------------------------------------------------------------------------------------|
| <b>Purpose</b>     | Select entire extent of data space                                                                                                                                                                                                                                                                                       |
| <b>Syntax</b>      | <code>H5S.select_all(space_id)</code>                                                                                                                                                                                                                                                                                    |
| <b>Description</b> | <code>H5S.select_all(space_id)</code> selects the entire extent of the data space specified by <code>space_id</code> .                                                                                                                                                                                                   |
| <b>Examples</b>    | <pre>fid = H5F.open('example.h5'); dset_id = H5D.open(fid, '/g3/integer'); space_id = H5D.get_space(dset_id); num_points1 = H5S.get_select_npoints(space_id); H5S.select_none(space_id); num_points2 = H5S.get_select_npoints(space_id); H5S.select_all(space_id); num_points3 = H5S.get_select_npoints(space_id);</pre> |

# H5S.select\_elements

---

**Purpose** Specify coordinates to include in selection

**Syntax** `H5S.select_elements(space_id,op,h5_coord)`

**Description** `H5S.select_elements(space_id,op,h5_coord)` selects the array elements to be included in the selection for the data space specified by `space_id`. The `op` argument determines how the new selection is to be combined with the previously existing selection for the data space and can be specified by one of the following string values.

'H5S\_SELECT\_SET'

'H5S\_SELECT\_APPEND'

'H5S\_SELECT\_PREPEND'

`h5_coord` is a two-dimensional array of 0-based values specifying the coordinates of the elements being selected. If `m` is the rank of the data space and if `n` is the number of points, then `h5_coord` should be an `m`-by-`n` array.

---

**Note** The HDF5 library uses C-style ordering for multidimensional arrays, while MATLAB uses FORTRAN-style ordering. The `h5_coord` parameter assumes coordinates have C-style ordering. Please consult "Using the MATLAB Low-Level HDF5 Functions" in the MATLAB documentation for more information.

---

**Examples** Select the corner points of a data space. In this case, `h5_coord` should have size `2x4`.

```
dims = [100 200];
h5_dims = fliplr(dims);
space_id = H5S.create_simple(2,h5_dims,h5_dims);
coords = [0 0; 0 199; 99 0; 99 199];
h5_coords = fliplr(coords);
h5_coords = h5_coords';
```

```
H5S.select_elements(space_id, 'H5S_SELECT_SET', h5_coords);
```

### See Also

```
H5S.create_simple | H5S.get_select_elem_npoints |
H5S.get_select_elem_pointlist
```

# H5S.select\_hyperslab

---

**Purpose** Select hyperslab region

**Syntax** `H5S.select_hyperslab(space_id,op,h5_start,h5_stride,h5_count,  
h5_block)`

**Description** `H5S.select_hyperslab(space_id,op,h5_start,h5_stride,h5_count,  
h5_block)` selects a hyperslab region to add to the current selected region for the data space specified by `space_id`. The `op` argument determines how the new selection is to be combined with the previously existing selection for the data space. Possible values include: `H5S_SELECT_SET`, `H5S_SELECT_OR`, `H5S_SELECT_AND`, `H5S_SELECT_XOR`, `H5S_SELECT_NOTA`, or `H5S_SELECT_NOTB`.

The `h5_start` array determines the starting coordinates of the hyperslab to select. The `h5_count` array determines how many blocks to select from the data space, in each dimension. The `h5_stride` array specifies how many elements to move in each dimension. The `h5_block` array determines the size of the element block selected from the data space.

If `h5_stride` is specified as `[]`, then a contiguous hyperslab is selected, as if each value in `h5_stride` were set to 1. If `h5_count` is specified as `[]`, the number of blocks selected along each dimension defaults to 1. If `h5_block` is specified as `[]`, then the block size defaults to a single element in each dimension, as if each value in the block array were set to 1.

---

**Note** The HDF5 library uses C-style ordering for multidimensional arrays, while MATLAB uses FORTRAN-style ordering. The `h5_start`, `h5_stride`, `h5_count` and `h5_block` parameters assume C-style ordering. Please consult "Using the MATLAB Low-Level HDF5 Functions" in the MATLAB documentation for more information.

---

**Examples**

```
dims = [100 200];
h5_dims = fliplr(dims);
```

```
space_id = H5S.create_simple(2,h5_dims,h5_dims);
start = fliplr([10 20]); block = fliplr([20 30]);
H5S.select_hyperslab(space_id,'H5S_SELECT_SET',start,[],[],block);
```

### See Also

H5S.create\_simple

# H5S.select\_none

---

**Purpose**                 Reset selection region to include no elements

**Syntax**                 H5S.select\_none(space\_id)

**Description**           H5S.select\_none(space\_id) resets the selection region for the data space space\_id to include no elements.

**Examples**

```
fid = H5F.open('example.h5');
dset_id = H5D.open(fid, '/g3/integer');
space_id = H5D.get_space(dset_id);
num_points1 = H5S.get_select_npoints(space_id);
H5S.select_none(space_id);
num_points2 = H5S.get_select_npoints(space_id);
```



**Purpose** Determine validity of selection

**Syntax** `output = H5S.select_valid(space_id)`

**Description** `output = H5S.select_valid(space_id)` returns a positive value if the selection of the data space `space_id` is within the extent of that data space, and zero if it is not. A negative value indicates failure.

**Examples**

```
dims = [100 200];
h5_dims = fliplr(dims);
space_id = H5S.create_simple(2,h5_dims,h5_dims);
start = fliplr([90 190]); count = [11 11];
H5S.select_hyperslab(space_id,'H5S_SELECT_SET',start,[],count,[]);
valid = H5S.select_valid(space_id);
```

**See Also** `H5S.create_simple` | `H5S.select_hyperslab`

# H5S.set\_extent\_none

---

**Purpose** Remove extent from data space

**Syntax** `H5S.set_extent_none(space_id)`

**Description** `H5S.set_extent_none(space_id)` removes the extent from a data space and sets the type to `H5S_NO_CLASS`.

**Examples**

```
fid = H5F.open('example.h5');
dset_id = H5D.open(fid, '/g3/integer2D');
space_id = H5D.get_space(dset_id);
H5S.set_extent_none(space_id);
extent_type = H5S.get_simple_extent_type(space_id);
switch(extent_type)
 case H5ML.get_constant_value('H5S_SCALAR')
 fprintf('scalar\n');
 case H5ML.get_constant_value('H5S_SIMPLE')
 fprintf('simple\n');
 case H5ML.get_constant_value('H5S_NO_CLASS')
 fprintf('no class\n');
end
```

**See Also** `H5S.get_simple_extent_dims`

|                    |                                                                                                                                                                                                                                                                                                                                                                                                                    |
|--------------------|--------------------------------------------------------------------------------------------------------------------------------------------------------------------------------------------------------------------------------------------------------------------------------------------------------------------------------------------------------------------------------------------------------------------|
| <b>Purpose</b>     | Set size of data space                                                                                                                                                                                                                                                                                                                                                                                             |
| <b>Syntax</b>      | <code>H5S.set_extent_simple(space_id,rank,h5_dims,h5_maxdims)</code>                                                                                                                                                                                                                                                                                                                                               |
| <b>Description</b> | <code>H5S.set_extent_simple(space_id,rank,h5_dims,h5_maxdims)</code> sets the size of the data space identified by <code>space_id</code> . The <code>rank</code> argument is the number of dimensions used in the data space. <code>h5_dims</code> is an array specifying the size of each dimension of the dataset. <code>h5_maxdims</code> is an array specifying the upper limit on the size of each dimension. |

---

**Note** The HDF5 library uses C-style ordering for multidimensional arrays, while MATLAB uses FORTRAN-style ordering. The `h5_dims` and `h5_maxdims` parameters assume C-style ordering. Please consult "Using the MATLAB Low-Level HDF5 Functions" in the MATLAB documentation for more information.

---

|                 |                                                                                                                                                                                                                                          |
|-----------------|------------------------------------------------------------------------------------------------------------------------------------------------------------------------------------------------------------------------------------------|
| <b>Examples</b> | <pre>space_id = H5S.create('H5S_SIMPLE'); dims = [100 200]; h5_dims = fliplr(dims); maxdims = [100 H5ML.get_constant_value('H5S_UNLIMITED')]; h5_maxdims = fliplr(maxdims); H5S.set_extent_simple(space_id,2,h5_dims, h5_maxdims);</pre> |
|-----------------|------------------------------------------------------------------------------------------------------------------------------------------------------------------------------------------------------------------------------------------|

|                 |                                                                                                          |
|-----------------|----------------------------------------------------------------------------------------------------------|
| <b>See Also</b> | <code>H5S.create</code>   <code>H5S.get_simple_extent_dims</code>   <code>H5ML.get_constant_value</code> |
|-----------------|----------------------------------------------------------------------------------------------------------|

# H5T.close

---

|                    |                                                                                            |
|--------------------|--------------------------------------------------------------------------------------------|
| <b>Purpose</b>     | Close data type                                                                            |
| <b>Syntax</b>      | <code>H5T.close(type_id)</code>                                                            |
| <b>Description</b> | <code>H5T.close(type_id)</code> releases the data type specified by <code>type_id</code> . |
| <b>See Also</b>    | <code>H5A.get_type</code>   <code>H5D.get_type</code>                                      |

**Purpose** Commit transient data type

**Syntax** `H5T.commit(loc_id,name,type_id)`  
`H5T.commit(loc_id,name,type_id,lcpl_id,tcpl_id,tapl_id)`

**Description** `H5T.commit(loc_id,name,type_id)` commits a transient data type to a file, creating a new named data type. `loc_id` is a file or group identifier. `name` is the name of the data type and `type_id` is the data type id. This interface corresponds to the 1.6.x version of H5Tcommit.

`H5T.commit(loc_id,name,type_id,lcpl_id,tcpl_id,tapl_id)` commits a transient data type to a file, creating a new named data type. `loc_id` is a file or group identifier. `name` is the name of the data type and `type_id` is the data type id. `lcpl_id`, `tcpl_id`, and `tapl_id` are link creation, data type creation, and data type access property list identifiers. This interface corresponds to the 1.8.x version of H5Tcommit.

**Examples** Create a named variable-length data type.

```
plist_id = 'H5P_DEFAULT';
fid = H5F.create('myfile.h5', 'H5F_ACC_TRUNC', plist_id, plist_id);
base_type_id = H5T.copy('H5T_NATIVE_DOUBLE');
vlen_type_id = H5T.vlen_create(base_type_id);
H5T.commit(fid, 'MyVlen', vlen_type_id);
H5T.close(vlen_type_id);
H5T.close(base_type_id);
H5F.close(fid);
```

**See Also** `H5T.close` | `H5T.committed`

# H5T.committed

---

|                    |                                                                                                                                                                                                    |
|--------------------|----------------------------------------------------------------------------------------------------------------------------------------------------------------------------------------------------|
| <b>Purpose</b>     | Determine if data type is committed                                                                                                                                                                |
| <b>Syntax</b>      | <code>output = H5T.committed(type_id)</code>                                                                                                                                                       |
| <b>Description</b> | <code>output = H5T.committed(type_id)</code> returns a positive value to indicate that the data type has been committed, and zero to indicate that it has not. A negative value indicates failure. |
| <b>Examples</b>    | <pre>type_id = H5T.copy('H5T_NATIVE_DOUBLE'); is_committed = H5T.committed(type_id);</pre>                                                                                                         |
| <b>See Also</b>    | <code>H5T.commit</code>                                                                                                                                                                            |

**Purpose** Copy data type

**Syntax** `output_type_id = H5T.copy(type_id)`

**Description** `output_type_id = H5T.copy(type_id)` copies the existing data type identifier, a dataset identifier specified by `type_id`, or a predefined data type such as `'H5T_NATIVE_DOUBLE'`. `output_type_id` is a data type identifier.

**Examples**

```
type_id = H5T.copy('H5T_NATIVE_DOUBLE');
type_size = H5T.get_size(type_id);
```

**See Also** `H5T.get_size`

# H5T.create

---

**Purpose** Create new data type

**Syntax** `output = H5T.create(class_id,size)`

**Description** `output = H5T.create(class_id,size)` creates a new data type of the class specified by `class_id`, with the number of bytes specified by `size`. The output argument is a data type identifier.

**Examples** Create a signed 32-bit enumerated data type.

```
type_id = H5T.create('H5T_ENUM',4);
H5T.set_order(type_id,'H5T_ORDER_LE');
H5T.set_sign(type_id,'H5T_SGN_2');
H5T.enum_insert(type_id,'black',0);
H5T.enum_insert(type_id,'white',1);
```

**See Also** [H5T.set\\_order](#) | [H5T.set\\_sign](#)



|                    |                                                                                                                                                                                                                                                                                                    |
|--------------------|----------------------------------------------------------------------------------------------------------------------------------------------------------------------------------------------------------------------------------------------------------------------------------------------------|
| <b>Purpose</b>     | Determine if data type contains specific class                                                                                                                                                                                                                                                     |
| <b>Syntax</b>      | <code>output = H5T.detect_class(type_id,class_id)</code>                                                                                                                                                                                                                                           |
| <b>Description</b> | <code>output = H5T.detect_class(type_id,class_id)</code> returns a positive value if the data type specified in <code>type_id</code> contains any data types of the data type class specified in <code>class_id</code> , or zero to indicate that it does not. A negative value indicates failure. |
| <b>Examples</b>    | <pre>fid = H5F.open('example.h5'); dset_id = H5D.open(fid,'/g3/vlen'); type_id = H5D.get_type(dset_id); has_double = H5T.detect_class(type_id,'H5T_FLOAT');</pre>                                                                                                                                  |
| <b>See Also</b>    | <code>H5D.get_type</code>                                                                                                                                                                                                                                                                          |

# H5T.equal

---

**Purpose** Determine equality of data types

**Syntax** `output = H5T.equal(type1_id,type2_id)`

**Description** `output = H5T.equal(type1_id,type2_id)` returns a positive number if the data type identifiers refer to the same data type, and zero to indicate that they do not. A negative value indicates failure. Either of the input values could be a string corresponding to an HDF5 data type.

**Examples** Determine if the data type of a dataset is a 32-bit little endian integer.

```
fid = H5F.open('example.h5');
dset_id = H5D.open(fid, '/g3/integer2D');
dtype_id = H5D.get_type(dset_id);
if H5T.equal(dtype_id, 'H5T_STD_I32LE')
 fprintf('32-bit little endian integer\n');
end
```

**See Also** `H5D.get_type`

**Purpose**

Data type class identifier

**Syntax**

```
class_id = H5T.get_class(type_id)
```

**Description**

`class_id = H5T.get_class(type_id)` returns the data type class identifier of the data type specified by `type_id`.

Valid class identifiers include:

```
H5T_INTEGER
H5T_FLOAT
H5T_STRING
H5T_BITFIELD
H5T_OPAQUE
H5T_COMPOUND
H5T_ENUM
H5T_VLEN
H5T_ARRAY
```

**Examples**

```
fid = H5F.open('example.h5');
dset_id = H5D.open(fid, '/g3/enum');
type_id = H5D.get_type(dset_id);
class_id = H5T.get_class(type_id);
switch(class_id)
 case H5ML.get_constant_value('H5T_INTEGER')
 fprintf('Integer\n');
 case H5ML.get_constant_value('H5T_FLOAT')
 fprintf('Floating point\n');
 case H5ML.get_constant_value('H5T_STRING')
 fprintf('String\n');
 case H5ML.get_constant_value('H5T_BITFIELD')
 fprintf('Bitfield\n');
 case H5ML.get_constant_value('H5T_OPAQUE')
```

## H5T.get\_class

---

```
 fprintf('Opaque\n');
 case H5ML.get_constant_value('H5T_COMPOUND')
 fprintf('Compound\n');
 case H5ML.get_constant_value('H5T_ENUM')
 fprintf('Enumerated\n');
 case H5ML.get_constant_value('H5T_VLEN')
 fprintf('Variable length\n');
 case H5ML.get_constant_value('H5T_ARRAY')
 fprintf('Array\n');
end
```

### See Also

H5ML.get\_constant\_value

**Purpose** Copy of data type creation property list

**Syntax** `plist_id = H5T.get_create_plist(datatype_id)`

**Description** `plist_id = H5T.get_create_plist(datatype_id)` returns a property list identifier for the data type creation property list associated with the data type specified by `datatype_id`.

**See Also** `H5D.get_create_plist` | `H5F.get_create_plist`

# H5T.get\_native\_type

---

**Purpose** Native data type of dataset data type

**Syntax** `output = H5T.get_native_type(type_id,direction)`

**Description** `output = H5T.get_native_type(type_id,direction)` returns the equivalent native data type for the dataset data type specified in `type_id`. The `direction` argument indicates the order in which the library searches for a native data type match and must be either `'H5T_DIR_ASCEND'` or `'H5T_DIR_DESCEND'`.

**Purpose** Size of data type in bytes

**Syntax** `type_size = H5T.get_size(type_id)`

**Description** `type_size = H5T.get_size(type_id)` returns the size of a data type in bytes. `type_id` is a data type identifier.

**Examples** Determine the size of the data type for a specific dataset.

```
fid = H5F.open('example.h5');
dset_id = H5D.open(fid, '/g3/bitfield2D');
type_id = H5D.get_type(dset_id);
type_size = H5T.get_size(type_id);
```

**See Also** [H5T.set\\_size](#) | [H5D.get\\_type](#)

# H5T.get\_super

---

**Purpose** Base data type

**Syntax** `super_type_id = H5T.get_super(type_id)`

**Description** `super_type_id = H5T.get_super(type_id)` returns the base data type from which the data type specified by `type_id` is derived.

**Examples** Retrieve the base data type for an enumerated dataset.

```
fid = H5F.open('example.h5');
dset_id = H5D.open(fid, '/g3/enum');
dtype_id = H5D.get_type(dset_id);
super_type_id = H5T.get_super(dtype_id);
```



**Purpose** Lock data type

**Syntax** `H5T.lock(type_id)`

**Description** `H5T.lock(type_id)` locks the data type specified by `type_id`, making it read-only and non-destructible.

# H5T.open

---

**Purpose** Open named data type

**Syntax** `type_id = H5T.open(loc_id,name)`

**Description** `type_id = H5T.open(loc_id,name)` opens a named data type at the location specified by `loc_id` and returns an identifier for the data type. `loc_id` is either a file or group identifier.

This function corresponds to the `H5Topen1` function in the HDF5 library C API.

**See Also** [H5T.close](#) | [H5A.open](#) | [H5D.open](#) | [H5G.open](#) | [H5O.open](#)

**Purpose** Create array data type object

**Syntax**  
`array_type_id = H5T.array_create(base_id,h5_dims)`  
`array_type_id = H5T.array_create(base_id,rank,h5_dims,perms)`

**Description** `array_type_id = H5T.array_create(base_id,h5_dims)` creates a new array data type object. This interface corresponds to the 1.8 library version of `H5Tarray_create`.

`array_type_id = H5T.array_create(base_id,rank,h5_dims,perms)` creates a new array data type object. This interface corresponds to the 1.6 library version of `H5Tarray_create`. The `perms` parameter is not used at this time and can be omitted.

---

**Note** The HDF5 library uses C-style ordering for multidimensional arrays, while MATLAB uses FORTRAN-style ordering. The `h5_dims` parameter assumes C-style ordering. Please consult "Using the MATLAB Low-Level HDF5 Functions" in the MATLAB documentation for more information.

---

**Examples** Create a 100-by-200 double precision array data type.

```
base_type_id = H5T.copy('H5T_NATIVE_DOUBLE');
dims = [100 200];
h5_dims = flip1r(dims);
array_type = H5T.array_create(base_type_id,h5_dims);
```

**See Also** `H5T.get_array_dims` | `H5T.get_array_ndims`

# H5T.get\_array\_dims

---

**Purpose** Array dimension extents

**Syntax**  
`dimsizes = H5T.get_array_dims(type_id)`  
`[ndims,dimsizes,perm] = H5T.get_array_dims(type_id)`

**Description** `dimsizes = H5T.get_array_dims(type_id)` returns the sizes of the dimensions and the dimension permutations of the specified array data type object. This interface corresponds to the 1.8 version of `H5Tget_array_dims`.  
`[ndims,dimsizes,perm] = H5T.get_array_dims(type_id)` corresponds to the 1.6 version of the interface. It is strongly deprecated.

---

**Note** The HDF5 library uses C-style ordering for multidimensional arrays, while MATLAB uses FORTRAN-style ordering. Please consult "Using the MATLAB Low-Level HDF5 Functions" in the MATLAB documentation for more information.

---

**Examples**

```
fid = H5F.open('example.h5');
dset_id = H5D.open(fid, '/g3/array2D');
type_id = H5D.get_type(dset_id);
h5_dims = H5T.get_array_dims(type_id);
dims = fliplr(h5_dims);
```

**See Also** `H5T.array_create` | `H5T.get_array_ndims`

**Purpose** Rank of array data type

**Syntax** `output = H5T.get_array_ndims(type_id)`

**Description** `output = H5T.get_array_ndims(type_id)` returns the rank, the number of dimensions, of an array data type object.

**Examples**

```
fid = H5F.open('example.h5');
dset_id = H5D.open(fid, '/g3/array2D');
type_id = H5D.get_type(dset_id);
ndims = H5T.get_array_ndims(type_id);
```

**See Also** `H5T.get_array_dims`

# H5T.get\_cset

---

**Purpose** Character set of string data type

**Syntax** `cset = H5T.get_cset(type_id)`

**Description** `cset = H5T.get_cset(type_id)` returns the character set type of the data type specified by `type_id`.

**Examples**

```
fid = H5F.open('example.h5');
dset_id = H5D.open(fid, '/g3/string');
type_id = H5D.get_type(dset_id);
cset = H5T.get_cset(type_id);
switch(cset)
 case H5ML.get_constant_value('H5T_CSET_ASCII')
 fprintf('ASCII\n');
 case H5ML.get_constant_value('H5T_CSET_UTF8')
 fprintf('UTF-8\n');
end
```

**See Also** `H5T.set_cset`

|                    |                                                                                                                                                 |
|--------------------|-------------------------------------------------------------------------------------------------------------------------------------------------|
| <b>Purpose</b>     | Exponent bias of floating-point type                                                                                                            |
| <b>Syntax</b>      | <code>output = H5T.get_ebias(type_id)</code>                                                                                                    |
| <b>Description</b> | <code>output = H5T.get_ebias(type_id)</code> returns the exponent bias of a floating-point type. <code>type_id</code> is data type identifier.  |
| <b>Examples</b>    | <pre>fid = H5F.open('example.h5'); dset_id = H5D.open(fid, '/g3/float'); type_id = H5D.get_type(dset_id); ebias = H5T.get_ebias(type_id);</pre> |
| <b>See Also</b>    | <code>H5T.set_ebias</code>                                                                                                                      |

# H5T.get\_fields

---

**Purpose** Floating-point data type bit field information

**Syntax** `[spos, epos, esize, mpos, msize] = H5T.get_fields(type_id)`

**Description** `[spos, epos, esize, mpos, msize] = H5T.get_fields(type_id)` returns information about the locations of the various bit fields of a floating point data type. `type_id` is a data type identifier. `spos` is the floating-point sign bit. `epos` is the exponent bit-position. `esize` is the size of the exponent in bits. `mpos` is the mantissa bit-position. `msize` is the size of the mantissa in bits.

**Examples**

```
fid = H5F.open('example.h5');
dset_id = H5D.open(fid, '/g3/float');
type_id = H5D.get_type(dset_id);
[spos, epos, esize, mpos, msize] = H5T.get_fields(type_id);
```



**Purpose** Internal padding type for floating-point data types

**Syntax** `pad_type = H5T.get_inpad(type_id)`

**Description** `pad_type = H5T.get_inpad(type_id)` returns the internal padding type for unused bits in floating-point data types. `type_id` is a data type identifier. `pad_type` can be `H5T_PAD_ZERO`, `H5T_PAD_ONE`, or `H5T_PAD_BACKGROUND`.

**Examples**

```
fid = H5F.open('example.h5');
dset_id = H5D.open(fid, '/g3/float');
type_id = H5D.get_type(dset_id);
pad_type = H5T.get_inpad(type_id);
switch(pad_type)
 case H5ML.get_constant_value('H5T_PAD_ZERO')
 fprintf('pad zero\n');
 case H5ML.get_constant_value('H5T_PAD_ONE')
 fprintf('pad one\n');
 case H5ML.get_constant_value('H5T_PAD_BACKGROUND')
 fprintf('pad background\n');
end
```

**See Also** `H5T.set_inpad`

# H5T.get\_norm

---

**Purpose** Mantissa normalization type

**Syntax** `norm_type = H5T.get_norm(type_id)`

**Description** `norm_type = H5T.get_norm(type_id)` returns the mantissa normalization of a floating-point data type. `type_id` is a data type identifier. `norm_type` can be `H5T_NORM_IMPLIED`, `H5T_NORM_MSBSET`, or `H5T_NORM_NONE`.

**Examples**

```
fid = H5F.open('example.h5');
dset_id = H5D.open(fid, '/g3/float');
type_id = H5D.get_type(dset_id);
norm_type = H5T.get_norm(type_id);
switch(norm_type)
 case H5ML.get_constant_value('H5T_NORM_IMPLIED')
 fprintf('MSB of mantissa is not stored, always 1\n');
 case H5ML.get_constant_value('H5T_NORM_MSBSET')
 fprintf('MSB of mantissa is always 1\n');
 case H5ML.get_constant_value('H5T_NORM_NONE')
 fprintf('mantissa is not normalized\n');
end
```

**See Also** `H5T.set_norm`

**Purpose** Bit offset of first significant bit

**Syntax** `offset = H5T.get_offset(type_id)`

**Description** `offset = H5T.get_offset(type_id)` returns the offset of the first significant bit. `type_id` is a data type identifier.

**Examples**

```
fid = H5F.open('example.h5');
dset_id = H5D.open(fid, '/g3/float');
type_id = H5D.get_type(dset_id);
offset = H5T.get_offset(type_id);
```

**See Also** `H5T.set_offset`

# H5T.get\_order

---

**Purpose** Byte order of atomic data type

**Syntax** `output = H5T.get_order(type_id)`

**Description** `output = H5T.get_order(type_id)` returns the byte order of an atomic data type. `type_id` is a data type identifier. Possible return values are the constant values corresponding to the following strings:

```
'H5T_ORDER_LE'
'H5T_ORDER_BE'
'H5T_ORDER_VAX'
```

**Examples**

```
fid = H5F.open('example.h5');
dset_id = H5D.open(fid, '/g2/dset2.2');
type_id = H5D.get_type(dset_id);
switch(H5T.get_order(type_id))
 case H5ML.get_constant_value('H5T_ORDER_LE')
 fprintf('little endian\n');
 case H5ML.get_constant_value('H5T_ORDER_BE')
 fprintf('big endian\n');
 case H5ML.get_constant_value('H5T_ORDER_VAX')
 fprintf('vax\n');
end
```

**See Also** `H5T.set_order` | `H5ML.get_constant_value`

**Purpose** Padding type of least and most-significant bits

**Syntax** [lsb,msb] = H5T.get\_pad(type\_id)

**Description** [lsb,msb] = H5T.get\_pad(type\_id) returns the padding type of the least and most-significant bit padding. type\_id is a data type identifier. lsb is the least-significant bit padding type. msb is the most-significant bit padding type. Values for lsb and msb can be H5T\_PAD\_ZERO, H5T\_PAD\_ONE, or H5T\_PAD\_BACKGROUND.

## Examples

```
fid = H5F.open('example.h5');
dset_id = H5D.open(fid, '/g3/integer');
type_id = H5D.get_type(dset_id);
[lsb,msb] = H5T.get_pad(type_id);
switch(lsb)
 case H5ML.get_constant_value('H5T_PAD_ZERO')
 fprintf('lsb pad type is zeros\n');
 case H5ML.get_constant_value('H5T_PAD_ONE')
 fprintf('lsb pad type is ones\n');
 case H5ML.get_constant_value('H5T_PAD_BACKGROUND')
 fprintf('lsb pad type is background\n');
end
switch(msb)
 case H5ML.get_constant_value('H5T_PAD_ZERO')
 fprintf('msb pad type is zeros\n');
 case H5ML.get_constant_value('H5T_PAD_ONE')
 fprintf('msb pad type is ones\n');
 case H5ML.get_constant_value('H5T_PAD_BACKGROUND')
 fprintf('msb pad type is background\n');
end
```

**See Also** H5T.set\_pad

# H5T.get\_precision

---

**Purpose** Precision of atomic data type

**Syntax** `output = H5T.get_precision(type_id)`

**Description** `output = H5T.get_precision(type_id)` returns the precision of an atomic data type. `type_id` is a data type identifier.

**Examples**

```
fid = H5F.open('example.h5');
dset_id = H5D.open(fid, '/g3/integer');
type_id = H5D.get_type(dset_id);
numbits = H5T.get_precision(type_id);
```

**See Also** `H5T.set_precision`

**Purpose** Sign type for integer data type

**Syntax** `sign_type = H5T.get_sign(type_id)`

**Description** `sign_type = H5T.get_sign(type_id)` returns the sign type for an integer type. `type_id` is a data type identifier. Valid types are: `H5T_SGN_NONE` or `H5T_SGN_2`.

**Examples**

```
fid = H5F.open('example.h5');
dset_id = H5D.open(fid, '/g3/integer');
type_id = H5D.get_type(dset_id);
sign_type = H5T.get_sign(type_id);
switch(sign_type)
 case H5ML.get_constant_value('H5T_SGN_NONE')
 fprintf('Unsigned integer type.\n');
 case H5ML.get_constant_value('H5T_SGN_2')
 fprintf('Signed integer type.\n');
end
```

**See Also** `H5T.set_sign`

# H5T.get\_strpad

---

**Purpose** Storage mechanism for string data type

**Syntax** `output = H5T.get_strpad(type_id)`

**Description** `output = H5T.get_strpad(type_id)` returns the storage mechanism (padding type) for a string data type. Possible values are:

|                               |                 |
|-------------------------------|-----------------|
| <code>H5T_STR_NULLPAD</code>  | Pad with zeros  |
| <code>H5T_STR_NULLTERM</code> | Null-terminate  |
| <code>H5T_STR_SPACEPAD</code> | Pad with spaces |

## Examples

```
fid = H5F.open('example.h5');
dset_id = H5D.open(fid, '/g3/string');
type_id = H5D.get_type(dset_id);
padding = H5T.get_strpad(type_id);
switch(padding)
 case H5ML.get_constant_value('H5T_STR_NULLTERM')
 fprintf('null-terminated\n');
 case H5ML.get_constant_value('H5T_STR_NULLPAD')
 fprintf('padded with zeros\n');
 case H5ML.get_constant_value('H5T_STR_SPACEPAD')
 fprintf('padded with spaces\n');
end
```

**See Also** `H5T.set_strpad`



**Purpose** Set character dataset for string data type

**Syntax** `H5T.set_cset(type_id, cset)`

**Description** `H5T.set_cset(type_id, cset)` sets the character encoding used to create strings. The only valid type is `H5T_CSET_ASCII`.

**Examples**

```
type_id = H5T.copy('H5T_C_S1');
H5T.set_size(type_id,10);
encoding = H5ML.get_constant_value('H5T_CSET_ASCII');
H5T.set_cset(type_id,encoding);
```

**See Also** `H5T.get_cset`

# H5T.set\_ebias

---

**Purpose** Set exponent bias of floating-point data type

**Syntax** `H5T.set_ebias(type_id,ebias)`

**Description** `H5T.set_ebias(type_id,ebias)` sets the exponent bias of a floating-point type. `type_id` is a data type identifier. `ebias` is an exponent bias value.

**Examples**

```
type_id = H5T.copy('H5T_NATIVE_FLOAT');
H5T.set_size(type_id,32);
H5T.set_ebias(type_id,99);
```

**See Also** `H5T.get_ebias`

|                    |                                                                                                                                                                                                                                                                                                                                                                                            |
|--------------------|--------------------------------------------------------------------------------------------------------------------------------------------------------------------------------------------------------------------------------------------------------------------------------------------------------------------------------------------------------------------------------------------|
| <b>Purpose</b>     | Set sizes and locations of floating-point bit fields                                                                                                                                                                                                                                                                                                                                       |
| <b>Syntax</b>      | <code>H5T.set_fields(type_id, spos, epos, esize, mpos, msize)</code>                                                                                                                                                                                                                                                                                                                       |
| <b>Description</b> | <code>H5T.set_fields(type_id, spos, epos, esize, mpos, msize)</code> sets the locations and sizes of the various floating-point bit fields. <code>spos</code> is the sign position. <code>epos</code> is the exponent in bits. <code>esize</code> is the size of exponent in bits. <code>mpos</code> is the mantissa bit position. <code>msize</code> is the size of the mantissa in bits. |
| <b>Examples</b>    | <pre>type_id = H5T.copy('H5T_NATIVE_DOUBLE'); H5T.set_fields(type_id,30,24,6,0,2);</pre>                                                                                                                                                                                                                                                                                                   |
| <b>See Also</b>    | <code>H5T.get_fields</code>                                                                                                                                                                                                                                                                                                                                                                |

# H5T.set\_inpad

---

**Purpose** Specify how unused internal bits are to be filled

**Syntax** `H5T.set_inpad(type_id,pad)`

**Description** `H5T.set_inpad(type_id,pad)` sets how unused internal bits of a floating point type are filled. `type_id` is the identifier of the data type. `inpad` specifies how to fill the bits: `H5T_PAD_ZERO`, `H5T_PAD_ONE`, or `H5T_PAD_BACKGROUND` (leave background alone).

**Examples**

```
type_id = H5T.copy('H5T_NATIVE_FLOAT');
pad_type = H5ML.get_constant_value('H5T_PAD_ZERO');
H5T.set_inpad(type_id,pad_type);
```

**See Also** `H5T.get_inpad`

|                    |                                                                                                                                                                                                                                      |
|--------------------|--------------------------------------------------------------------------------------------------------------------------------------------------------------------------------------------------------------------------------------|
| <b>Purpose</b>     | Set mantissa normalization of floating-point data type                                                                                                                                                                               |
| <b>Syntax</b>      | <code>H5T.set_norm(type_id,norm)</code>                                                                                                                                                                                              |
| <b>Description</b> | <code>H5T.set_norm(type_id,norm)</code> sets the mantissa normalization of a floating-point data type. Valid normalization types are: <code>H5T_NORM_IMPLIED</code> , <code>H5T_NORM_MSBSET</code> , or <code>H5T_NORM_NONE</code> . |
| <b>Examples</b>    | <pre>type_id = H5T.copy('H5T_NATIVE_FLOAT'); norm_type = H5ML.get_constant_value('H5T_NORM_MSBSET'); H5T.set_norm(type_id,norm_type);</pre>                                                                                          |
| <b>See Also</b>    | <code>H5T.get_norm</code>                                                                                                                                                                                                            |

# H5T.set\_offset

---

**Purpose** Set bit offset of first significant bit

**Syntax** `H5T.set_offset(type_id,offset)`

**Description** `H5T.set_offset(type_id,offset)` sets the bit offset of the first significant bit. `type_id` is the identifier of the data type. `offset` specifies the number of bits of padding that appear.

**Examples**

```
type_id = H5T.copy('H5T_NATIVE_INT');
H5T.set_offset(type_id,16);
```

**See Also** `H5T.get_offset`

**Purpose** Set byte ordering of atomic data type

**Syntax** `H5T.set_order(type_id,type_order)`

**Description** `H5T.set_order(type_id,type_order)` sets the byte ordering of an atomic data type. `type_order` can be one of the following values:

`H5T_ORDER_LE`  
`H5T_ORDER_BE`  
`H5T_ORDER_VAX`

**Examples** Create a big endian 32-bit integer type.

```
type_id = H5T.copy('H5T_NATIVE_INT');
order = H5ML.get_constant_value('H5T_ORDER_BE');
H5T.set_order(type_id,order);
```

**See Also** `H5T.get_order` | `H5ML.get_constant_value`

# H5T.set\_pad

---

**Purpose** Set padding type for least and most significant bits

**Syntax** `H5T.set_pad(type_id,lsb,msb)`

**Description** `H5T.set_pad(type_id,lsb,msb)` sets the padding type for the least and most-significant bits. `type_id` is the identifier of the data type. `lsb` specifies the padding type for least-significant bits; `msb` for most-significant bits. Valid padding types are `H5T_PAD_ZERO`, `H5T_PAD_ONE`, or `H5T_PAD_BACKGROUND` (leave background alone).

**Examples**

```
type_id = H5T.copy('H5T_NATIVE_INT');
lsb = H5ML.get_constant_value('H5T_PAD_ONE');
msb = H5ML.get_constant_value('H5T_PAD_ZERO');
H5T.set_pad(type_id,lsb,msb);
```

**See Also** `H5T.get_pad`



**Purpose** Set precision of atomic data type

**Syntax** `H5T.set_precision(type_id,prec)`

**Description** `H5T.set_precision(type_id,prec)` sets the precision of an atomic data type. `type_id` is a data type identifier. `prec` specifies the number of bits of precision for the data type.

# H5T.set\_sign

---

**Purpose** Set sign property for integer data type

**Syntax** `H5T.set_sign(type_id,sign)`

**Description** `H5T.set_sign(type_id,sign)` sets the sign property for an integer type. `type_id` is a data type identifier. `sign` specifies the sign type. Valid values are `H5T_SGN_NONE` or `H5T_SGN_2`.

**Examples**

```
type_id = H5T.copy('H5T_NATIVE_LONG');
sgn = H5ML.get_constant_value('H5T_SGN_NONE');
H5T.set_sign(type_id,sgn);
```

**See Also** `H5T.get_sign`

|                    |                                                                                                                                                                                                                                 |
|--------------------|---------------------------------------------------------------------------------------------------------------------------------------------------------------------------------------------------------------------------------|
| <b>Purpose</b>     | Set size of data type in bytes                                                                                                                                                                                                  |
| <b>Syntax</b>      | <code>H5T.set_size(type_id,type_size)</code>                                                                                                                                                                                    |
| <b>Description</b> | <code>H5T.set_size(type_id,type_size)</code> sets the total size in bytes for the data type specified by <code>type_id</code> . The string <code>'H5T_VARIABLE'</code> can also be used if a variable length string is desired. |
| <b>Examples</b>    | Create a variable length string with null termination.<br><br><pre>type_id = H5T.copy('H5T_C_S1');<br/>H5T.set_size(type_id,'H5T_VARIABLE');<br/>H5T.set_strpad(type_id,'H5T_STR_NULLTERM');</pre>                              |
| <b>See Also</b>    | <code>H5T.get_size</code>                                                                                                                                                                                                       |

# H5T.set\_strpad

---

**Purpose** Set storage mechanism for string data type

**Syntax** `H5T.set_strpad(type_id,storage_type)`

**Description** `H5T.set_strpad(type_id,storage_type)` defines the storage mechanism for the string data type identified by `type_id`. The storage type may be one of the following values.

|                                 |                    |
|---------------------------------|--------------------|
| <code>'H5T_STR_NULLTERM'</code> | Null terminated    |
| <code>'H5T_STR_NULLPAD'</code>  | Padded with zeros  |
| <code>'H5T_STR_SPACEPAD'</code> | Padded with spaces |

**Examples** Create a ten-character string data type with space padding.

```
type_id = H5T.copy('H5T_C_S1');
H5T.set_size(type_id,10);
H5T.set_strpad(type_id,'H5T_STR_SPACEPAD');
```

**See Also** `H5T.get_strpad`

**Purpose** Data type class for compound data type member

**Syntax** `output = H5T.get_member_class(type_id, membno)`

**Description** `output = H5T.get_member_class(type_id, membno)` returns the data type class of the compound data type member specified by `membno`. The `type_id` argument is the data type identifier of a compound object.

**Examples**

```
fid = H5F.open('example.h5');
dset_id = H5D.open(fid, '/g3/compound');
type_id = H5D.get_type(dset_id);
member_name = H5T.get_member_name(type_id, 0);
member_class = H5T.get_member_class(type_id, 0);
```

**See Also** `H5T.get_member_name`

# H5T.get\_member\_index

---

**Purpose** Index of compound or enumeration type member

**Syntax** `idx = H5T.get_member_index(type_id,name)`

**Description** `idx = H5T.get_member_index(type_id,name)` returns the index of a field of a compound data type or an element of an enumeration data type. `type_id` is a data type identifier and `name` is a text string that identifies the target field or element.

**Examples**

```
fid = H5F.open('example.h5');
dset_id = H5D.open(fid, '/g3/compound');
type_id = H5D.get_type(dset_id);
idx = H5T.get_member_index(type_id, 'b');
```

**See Also** `H5T.get_member_name`

**Purpose** Name of compound or enumeration type member

**Syntax** `name = H5T.get_member_name(type_id, membno)`

**Description** `name = H5T.get_member_name(type_id, membno)` returns the name of a field of a compound data type or an element of an enumeration data type. `type_id` is a data type identifier. `membno` is a zero-based index of the field or element whose name is to be retrieved.

**Examples** Determine the name of the first field of a compound dataset.

```
fid = H5F.open('example.h5');
dset_id = H5D.open(fid, '/g3/compound');
dtype_id = H5D.get_type(dset_id);
member_name = H5T.get_member_name(dtype_id, 0);
```

**See Also** `H5T.get_member_index`

# H5T.get\_member\_offset

---

**Purpose** Offset of field of compound data type

**Syntax** `output = H5T.get_member_offset(type_id, membno)`

**Description** `output = H5T.get_member_offset(type_id, membno)` returns the byte offset of the field specified by `membno` in the compound data type specified by `type_id`. Note that zero (0) is a valid offset.

**Examples**

```
fid = H5F.open('example.h5');
dset_id = H5D.open(fid, '/g3/compound');
type_id = H5D.get_type(dset_id);
idx = H5T.get_member_offset(type_id, 1);
```

**See Also** `H5T.get_member_name`



**Purpose** Data type of specified member

**Syntax** `type_id = H5T.get_member_type(type_id, membno)`

**Description** `type_id = H5T.get_member_type(type_id, membno)` returns the data type of the member specified by `membno` in the data type specified by `type_id`.

**Examples** Get the size of the data type of the first member of a compound data type.

```
fid = H5F.open('example.h5');
dset_id = H5D.open(fid, '/g3/compound');
compound_type_id = H5D.get_type(dset_id);
member_type_id = H5T.get_member_type(compound_type_id, 0);
type_size = H5T.get_size(member_type_id);
```

**See Also** `H5D.get_type`

# H5T.get\_nmembers

---

**Purpose**            Number of elements in enumeration type

**Syntax**            `output = H5T.get_nmembers(type_id)`

**Description**       `output = H5T.get_nmembers(type_id)` retrieves the number of fields in a compound data type or the number of members of an enumeration data type. `type_id` is a data type identifier.

**Examples**           Determine the number of fields in a compound dataset.

```
fid = H5F.open('example.h5');
dset_id = H5D.open(fid, '/g3/compound');
dtype_id = H5D.get_type(dset_id);
nmembers = H5T.get_nmembers(dtype_id);
```

**Purpose**

Add member to compound data type

**Syntax**

```
H5T.insert(type_id,name,offset,member_datatype)
```

**Description**

`H5T.insert(type_id,name,offset,member_datatype)` adds another member to the compound data type specified by `type_id`. The `name` argument is a text string that specifies the name of the new member, which must be unique in the compound data type. `offset` specifies where you want to insert the new member and `member_datatype` specifies the data type identifier of the new member.

**Examples**

```
type_id = H5T.create('H5T_COMPOUND',16);
H5T.insert(type_id,'first',0,'H5T_NATIVE_DOUBLE');
H5T.insert(type_id,'second',8,'H5T_NATIVE_INT');
H5T.insert(type_id,'third',12,'H5T_NATIVE_UINT');
```

**See Also**

`H5T.create`

# H5T.pack

---

**Purpose** Recursively remove padding from compound data type

**Syntax** `H5T.pack(type_id)`

**Description** `H5T.pack(type_id)` recursively removes padding from within a compound data type to make it more efficient (space-wise) to store that data. `type_id` is a data type identifier.

**Purpose** Create new enumeration data type

**Syntax** `output = H5T.enum_create(parent_id)`

**Description** `output = H5T.enum_create(parent_id)` creates a new enumeration data type based on the specified base data type, `parent_id`, which must be an integer type. `output` is a data type identifier for the new enumeration data type.

**Examples**

```
parent_id = H5T.copy('H5T_NATIVE_UINT');
type_id = H5T.enum_create(parent_id);
H5T.enum_insert(type_id, 'red', 1);
H5T.enum_insert(type_id, 'green', 2);
H5T.enum_insert(type_id, 'blue', 3);
H5T.close(type_id);
H5T.close(parent_id);
```

**See Also** `H5T.enum_insert`

# H5T.enum\_insert

---

**Purpose** Insert enumeration data type member

**Syntax** `H5T.enum_insert(type_id,name,value)`

**Description** `H5T.enum_insert(type_id,name,value)` inserts a new enumeration data type member into the enumeration data type specified by `type_id`. The `name` argument is a text string that specifies the name of the new member of the enumeration and `value` is the value of the member.

**Examples**

```
parent_id = H5T.copy('H5T_NATIVE_UINT');
type_id = H5T.enum_create(parent_id);
H5T.enum_insert(type_id,'red',1);
H5T.enum_insert(type_id,'green',2);
H5T.enum_insert(type_id,'blue',3);
H5T.close(type_id);
H5T.close(parent_id);
```

**See Also** `H5T.enum_create`

**Purpose** Name of enumeration data type member

**Syntax** `name = H5T.enum_nameof(type_id,value)`

**Description** `name = H5T.enum_nameof(type_id,value)` returns the symbol name corresponding to a member of an enumeration data type. `type_id` specifies the enumeration data type. `value` identifies the member of the enumeration.

**Examples**

```
fid = H5F.open('example.h5');
dset_id = H5D.open(fid, '/g3/enum');
type_id = H5D.get_type(dset_id);
name0 = H5T.enum_nameof(type_id,int32(0));
name1 = H5T.enum_nameof(type_id,int32(1));
```

**See Also** `H5T.enum_valueof`

# H5T.enum\_valueof

---

**Purpose** Value of enumeration data type member

**Syntax** `value = H5T.enum_valueof(type_id,member_name)`

**Description** `value = H5T.enum_valueof(type_id,member_name)` returns the value corresponding to a specified member of an enumeration data type. `type_id` specifies the enumeration data type and `member_name` specifies the member.

**Examples**

```
fid = H5F.open('example.h5');
dset_id = H5D.open(fid, '/g3/enum');
type_id = H5D.get_type(dset_id);
num_members = H5T.get_nmembers(type_id);
for j = 1:num_members
 member_name{j} = H5T.get_member_name(type_id,j-1);
 member_value(j) = H5T.enum_valueof(type_id,member_name{j});
end
```

**See Also** `H5T.get_member_name` | `H5T.get_nmembers`



**Purpose** Value of enumeration data type member

**Syntax** `value = H5T.get_member_value(type_id, membno)`

**Description** `value = H5T.get_member_value(type_id, membno)` returns the value of the enumeration data type member specified by `membno`. The `type_id` argument is the data type identifier for the enumeration data type.

**Examples**

```
fid = H5F.open('example.h5');
dset_id = H5D.open(fid, '/g3/enum');
type_id = H5D.get_type(dset_id);
num_members = H5T.get_nmembers(type_id);
for j = 1:num_members
 member_name{j} = H5T.get_member_name(type_id, j-1);
 member_value(j) = H5T.get_member_value(type_id, j-1);
end
```

**See Also** `H5T.get_member_name` | `H5T.get_nmembers`

# H5T.get\_tag

---

**Purpose** Tag associated with opaque data type

**Syntax** `tag = H5T.get_tag(type_id)`

**Description** `tag = H5T.get_tag(type_id)` returns the tag associated with the opaque data type specified by `type_id`.

**Examples**

```
fid = H5F.open('example.h5');
dset_id = H5D.open(fid, '/g3/opaque');
dtype_id = H5D.get_type(dset_id);
tag = H5T.get_tag(dtype_id);
```

**See Also** `H5T.set_tag`

|                    |                                                                                                                                                                                  |
|--------------------|----------------------------------------------------------------------------------------------------------------------------------------------------------------------------------|
| <b>Purpose</b>     | Tag opaque data type with description                                                                                                                                            |
| <b>Syntax</b>      | <code>H5T.set_tag(type_id,tag)</code>                                                                                                                                            |
| <b>Description</b> | <code>H5T.set_tag(type_id,tag)</code> tags the opaque data type specified by <code>type_id</code> , with the descriptive ASCII string identifier, <code>tag</code> .             |
| <b>Examples</b>    | Create an opaque data type with a length of 4 bytes and a particular tag.<br><br><pre>type_id = H5T.create('H5T_OPAQUE',4);<br/>H5T.set_tag(type_id,'Created by MATLAB.');</pre> |
| <b>See Also</b>    | <code>H5T.create</code>   <code>H5T.get_tag</code>                                                                                                                               |

# H5T.is\_variable\_str

---

**Purpose** Determine if data type is variable-length string

**Syntax** `output = H5T.is_variable_str(type_id)`

**Description** `output = H5T.is_variable_str(type_id)` returns a positive value if the data type specified by `type_id` is a variable-length string and zero if it is not. A negative value indicates failure.

**Examples**

```
fid = H5F.open('example.h5');
dset_id = H5D.open(fid, '/g3/VLstring2D');
type_id = H5D.get_type(dset_id);
if H5T.is_variable_str(type_id) > 0
 fprintf('variable length string\n');
end
```

**See Also** `H5T.vlen_create` | `H5T.get_size` | `H5D.get_type`

**Purpose** Create new variable-length data type

**Syntax** `vlen_type_id = H5T.vlen_create(base_id)`

**Description** `vlen_type_id = H5T.vlen_create(base_id)` creates a new variable-length (VL) data type. `base_id` specifies the base type of the data type to create.

**Examples** Create a variable length data type for 64-bit floating-point numbers.

```
base_type_id = H5T.copy('H5T_NATIVE_DOUBLE');
vlen_type_id = H5T.vlen_create(base_type_id);
```

**See Also** `H5T.is_variable_str`

# H5Z.filter\_avail

---

**Purpose** Determine if filter is available

**Syntax** `output = H5Z.filter_avail(filter_id)`

**Description** `output = H5Z.filter_avail(filter_id)` determines whether the filter specified by the filter identifier is available to the application. `filter_id` can be specified by one of the following strings or its numeric equivalent.

```
'H5Z_FILTER_DEFLATE'
'H5Z_FILTER_SHUFFLE'
'H5Z_FILTER_FLETCHER32'
'H5Z_FILTER_SZIP'
'H5Z_FILTER_NBIT'
'H5Z_FILTER_SCALEOFFSET'
```

**Examples** Determine if the shuffle filter is available.

```
bool = H5Z.filter_avail('H5Z_FILTER_SHUFFLE');
```

**See Also** `H5ML.get_constant_value`

**Purpose**

Information about filter

**Syntax**

```
filter_config_flags = H5Z.get_filter_info(filter)
```

**Description**

`filter_config_flags = H5Z.get_filter_info(filter)` retrieves information about the filter specified by its identifier. At present, the information returned is the filter's configuration flags, indicating whether the filter is configured to decode data, to encode data, neither, or both. `filter_config_flags` should be used with the HDF5 constant values `H5Z_FILTER_CONFIG_ENCODE_ENABLED` and `H5Z_FILTER_CONFIG_DECODE_ENABLED` in a bitwise AND operation. If the resulting value is 0, then the encode or decode functionality is not available.

**Examples**

Determine if encoding is enabled for the deflate filter.

```
flags = H5Z.get_filter_info('H5Z_FILTER_DEFLATE');
functionality = H5ML.get_constant_value('H5Z_FILTER_CONFIG_ENCODE_ENABLED');
enabled = bitand(flags,functionality) > 0;
```

**See Also**

`H5Z.filter_avail` | `H5ML.get_constant_value` | `bitand`

# hadamard

---

**Purpose** Hadamard matrix

**Syntax** `H = hadamard(n)`

**Description** `H = hadamard(n)` returns the Hadamard matrix of order `n`.

**Definitions** Hadamard matrices are matrices of 1's and -1's whose columns are orthogonal,

$$H' * H = n * I$$

where `[n n]=size(H)` and `I = eye(n,n)` .

They have applications in several different areas, including combinatorics, signal processing, and numerical analysis, [1], [2].

An `n`-by-`n` Hadamard matrix with `n > 2` exists only if `rem(n,4) = 0`. This function handles only the cases where `n`, `n/12`, or `n/20` is a power of 2.

**Examples** The command `hadamard(4)` produces the 4-by-4 matrix:

```
1 1 1 1
1 -1 1 -1
1 1 -1 -1
1 -1 -1 1
```

**References** [1] Ryser, H. J., *Combinatorial Mathematics*, John Wiley and Sons, 1963.

[2] Pratt, W. K., *Digital Signal Processing*, John Wiley and Sons, 1978.

**See Also** `compan` | `hankel` | `toeplitz`



**Purpose**

Abstract class for deriving handle classes

**Syntax**

```
classdef MyHandleClass < handle
```

**Description**

`classdef MyHandleClass < handle` makes *MyHandleClass* a subclass of the `handle` class.

The `handle` class is the superclass for all classes that follow `handle` semantics. A *handle* is a reference to an object. If you copy an object's `handle`, MATLAB copies only the `handle` and both the original and copy refer to the same object data. If a function modifies a `handle` object passed as an input argument, the modification affects the original input object.

In contrast, nonhandle objects (that is, value objects) are not references. Functions must return modified value objects to the caller to cause change to the object outside of the function's workspace.

See “Modifying Objects” for information on passing objects to functions.

Handle object behavior is like that of Handle Graphics objects, where the `handle` of a graphics object always refers to a particular instance regardless of whether you save the `handle` when you create the object, store it in another variable, or obtain it with convenience functions like `findobj`, `gca`, and so on.

If you want to create a class that defines events, you must derive that class from the `handle` class.

The `handle` class is an abstract class, so you cannot create an instance of this class directly. You use the `handle` class to derive other classes, which can be concrete classes whose instances are `handle` objects. See “Handle Classes” for information on using `handle` classes.

**Handle Class Methods**

When you derive a class from the `handle` class, your class inherits the following methods.

# handle

---

| Method                                                                                                                                    | Purpose                                                                                                                                                                                                                                                                                                                                                                                                                              |
|-------------------------------------------------------------------------------------------------------------------------------------------|--------------------------------------------------------------------------------------------------------------------------------------------------------------------------------------------------------------------------------------------------------------------------------------------------------------------------------------------------------------------------------------------------------------------------------------|
| <code>addlistener</code>                                                                                                                  | Creates a listener for the specified event and assigns a callback function to execute when the event occurs.                                                                                                                                                                                                                                                                                                                         |
| <code>notify</code>                                                                                                                       | Broadcast a notice that a specific event is occurring on a specified handle object or array of handle objects.                                                                                                                                                                                                                                                                                                                       |
| <code>delete</code>                                                                                                                       | Handle object destructor method that is called when the object's lifecycle ends.                                                                                                                                                                                                                                                                                                                                                     |
| <code>findobj</code>                                                                                                                      | Finds objects matching the specified conditions from the input array of handle objects.                                                                                                                                                                                                                                                                                                                                              |
| <code>findprop</code>                                                                                                                     | Returns a <code>meta.property</code> objects associated with the specified property name.                                                                                                                                                                                                                                                                                                                                            |
| <code>isvalid</code>                                                                                                                      | Returns a logical array in which elements are true if the corresponding elements in the input array are valid handles. This method is <b>Sealed</b> so you cannot override it in a handle subclass.                                                                                                                                                                                                                                  |
| <code>eq</code><br><code>ne</code><br><code>lt</code><br><code>le</code><br><code>gt</code><br><code>ge</code><br>Relational<br>Operators | Relational functions return a logical array of the same size as the pair of input handle object arrays. Comparisons use a number associated with each handle. You can assume that the same two handles will compare as equal and the repeated comparison of any two handles will yield the same result in the same MATLAB session. Different handles are always not-equal. The order of handles is purely arbitrary, but consistent. |

## Handle Class Events

The handle class defines one event:

`ObjectBeingDestroyed`

This event is triggered when the handle object is about to be destroyed. If you define a listener for this event, its callback executes before MATLAB destroys the handle object.

You can add a listener for this event using the `addlistener` method. See “Events and Listeners — Syntax and Techniques” for more information on using events and listeners.

You can define a `delete` method for a handle subclass that MATLAB calls when the object is destroyed. See “Handle Class Destructor”.

## Handle Subclasses

You can use the following abstract `handle` subclasses to derive more specialized handle classes:

- `hgsetget` – use when you want to create a handle class that inherits `set` and `get` methods having the same behavior as Handle Graphics `set` and `get` functions.
- `dynamicprops` – use when you want to create a handle class that allows you to add instance data (dynamically defined properties) to objects.
- `matlab.mixin.Copyable` – use to add a `copy` method to a handle subclass.

## Useful Functions

- `properties` — list the class public properties
- `methods` — list the class methods
- `events` — list the events defined by the class

Note that `ishandle` does not test for handle class objects. Use `isa` instead.

# hankel

---

**Purpose** Hankel matrix

**Syntax** `H = hankel(c)`  
`H = hankel(c,r)`

**Description** `H = hankel(c)` returns the square Hankel matrix whose first column is `c` and whose elements are zero below the first anti-diagonal.

`H = hankel(c,r)` returns a Hankel matrix whose first column is `c` and whose last row is `r`. If the last element of `c` differs from the first element of `r`, the last element of `c` prevails.

**Definitions** A Hankel matrix is a matrix that is symmetric and constant across the anti-diagonals, and has elements  $h(i,j) = p(i+j-1)$ , where vector `p = [c r(2:end)]` completely determines the Hankel matrix.

**Examples** A Hankel matrix with anti-diagonal disagreement is

```
c = 1:3; r = 7:10;
h = hankel(c,r)
h =
 1 2 3 8
 2 3 8 9
 3 8 9 10

p = [1 2 3 8 9 10]
```

**See Also** `hadamard` | `toeplitz` | `kron`

**Purpose** Information about HDF5 file

---

**Note** `hdf5info` will be removed in a future version. Use `h5info` instead.

---

**Syntax**

```
fileinfo = hdf5info(filename)
fileinfo = hdf5info(...,'ReadAttributes',BOOL)
[...] = hdf5info(..., 'V71Dimensions', BOOL)
```

**Description** `fileinfo = hdf5info(filename)` returns a structure `fileinfo` whose fields contain information about the contents of the HDF5 file `filename`. `filename` is a string that specifies the name of the HDF5 file.

`fileinfo = hdf5info(...,'ReadAttributes',BOOL)` specifies whether `hdf5info` returns the values of the attributes or just information describing the attributes. By default, `hdf5info` reads in attribute values (`BOOL = true`).

`[...] = hdf5info(..., 'V71Dimensions', BOOL)` specifies whether to report the dimensions of data sets and attributes as they were returned in previous versions of `hdf5info` (MATLAB 7.1 [R14SP3] and earlier). If `BOOL` is true, `hdf5info` swaps the first two dimensions of the data set. This behavior was intended to account for the difference in how HDF5 and MATLAB express array dimensions. HDF5 describes data set dimensions in row-major order; MATLAB stores data in column-major order. However, swapping these dimensions may not correctly reflect the intent of the data in the file and may invalidate metadata. When `BOOL` is false (the default), `hdf5info` returns data dimensions that correctly reflect the data ordering as it is written in the file—each dimension in the output variable matches the same dimension in the file.

# hdf5info

---

---

**Note** If you use the 'V71Dimensions' parameter and intend on passing the `fileinfo` structure returned to the `hdf5read` function, you should also specify the 'V71Dimensions' parameters with `hdf5read`. If you do not, `hdf5read` uses the new behavior when reading the data set and certain metadata returned by `hdf5info` does not match the actual data returned by `hdf5read`.

---

## Examples

```
fileinfo = hdf5info('example.h5');
```

To get more information about the contents of the HDF5 file, look at the `GroupHierarchy` field in the `fileinfo` structure returned by `hdf5info`.

```
toplevel = fileinfo.GroupHierarchy
```

```
toplevel =
```

```
 Filename: [1x64 char]
 Name: '/'
 Groups: [1x2 struct]
 Datasets: []
 Datatypes: []
 Links: []
 Attributes: [1x2 struct]
```

To probe further into the file hierarchy, keep examining the `Groups` field.

## See also

`hdf5read`, `hdf5write`

**Purpose** Read HDF5 file

---

**Note** `hdf5read` will be removed in a future version. Use `h5read` instead.

---

**Syntax**

```
data = hdf5read(filename,datasetname)
attr = hdf5read(filename,attributename)
[data, attr] = hdf5read(...,'ReadAttributes',B00L)
data = hdf5read(hinfo)
[...] = hdf5read(..., 'V71Dimensions', B00L)
```

**Description** `data = hdf5read(filename,datasetname)` reads all the data in the data set `datasetname` that is stored in the HDF5 file `filename` and returns it in the variable `data`. To determine the names of data sets in an HDF5 file, use the `hdf5info` function.

The return value, `data`, is a multidimensional array. `hdf5read` maps HDF5 data types to native MATLAB data types, whenever possible. If it cannot represent the data using MATLAB data types, `hdf5read` uses one of the HDF5 data type objects. For example, if an HDF5 file contains a data set made up of an enumerated data type, `hdf5read` uses the `hdf5.h5enum` object to represent the data in the MATLAB workspace. The `hdf5.h5enum` object has data members that store the enumerations (names), their corresponding values, and the enumerated data.

---

**Note** `hdf5read` performs best when reading numeric datasets. If you need to read string, compound, or variable length datasets, MathWorks strongly recommends that you use the low-level HDF5 interface function, `H5D.read`. To read a subset of a dataset, you must use the low-level interface.

---

`attr = hdf5read(filename,attributename)` reads all the metadata in the attribute `attributename`, stored in the HDF5 file `filename`, and

# hdf5read

---

returns it in the variable `attr`. To determine the names of attributes in an HDF5 file, use the `hdf5info` function.

`[data, attr] = hdf5read(..., 'ReadAttributes', BOOL)` reads all the data, as well as all of the associated attribute information contained within that data set. By default, `BOOL` is false.

`data = hdf5read(hinfo)` reads all of the data in the data set specified in the structure `hinfo` and returns it in the variable `data`. The `hinfo` structure is extracted from the output returned by `hdf5info`, which specifies an HDF5 file and a specific data set.

`[...] = hdf5read(..., 'V71Dimensions', BOOL)` specifies whether to change the majority of data sets read from the file. If `BOOL` is true, `hdf5read` permutes the first two dimensions of the data set, as it did in previous releases (MATLAB 7.1 [R14SP3] and earlier). This behavior was intended to account for the difference in how HDF5 and MATLAB express array dimensions. HDF5 describes data set dimensions in row-major order; MATLAB stores data in column-major order. However, permuting these dimensions may not correctly reflect the intent of the data and may invalidate metadata. When `BOOL` is false (the default), the data dimensions correctly reflect the data ordering as it is written in the file — each dimension in the output variable matches the same dimension in the file.

## Examples

Use `hdf5info` to get information about an HDF5 file and then use `hdf5read` to read a data set, using the information structure (`hinfo`) returned by `hdf5info` to specify the data set.

```
hinfo = hdf5info('example.h5');
dset = hdf5read(hinfo.GroupHierarchy.Groups(2).Datasets(1));
```

## See Also

`hdf5info` | `hdf5write`



**Purpose** Write data to file in HDF5 format

---

**Note** hdf5write will be removed in a future version. Use h5write instead.

---

**Syntax**

```
hdf5write(filename,location,dataset)
hdf5write(filename,details,dataset)
hdf5write(filename,details,attribute)
hdf5write(filename, details1, dataset1, details2, dataset2,...)
hdf5write(filename,...,'WriteMode',mode,...)
hdf5write(..., 'V71Dimensions', BOOL)
```

**Description** hdf5write(filename,location,dataset) writes the data dataset to the HDF5 file, filename. If filename does not exist, hdf5write creates it. If filename exists, hdf5write overwrites the existing file, by default, but you can also append data to an existing file using an optional syntax.

location defines where to write the data set in the file. HDF5 files are organized in a hierarchical structure similar to a UNIX directory structure. location is a string that resembles a UNIX path.

hdf5write maps the data in dataset to HDF5 data types according to rules outlined below.

hdf5write(filename,details,dataset) writes dataset to filename using the values in the details structure. For a data set, the details structure can contain the following fields.

| Field Name | Description                          | Data Type       |
|------------|--------------------------------------|-----------------|
| Location   | Location of the data set in the file | Character array |
| Name       | Name to attach to the data set       | Character array |

# hdf5write

---

`hdf5write(filename,details,attribute)` writes the metadata attribute to `filename` using the values in the `details` structure. For an attribute, the `details` structure can contain following fields.

| Field Name | Description                                                                                       | Data Type       |
|------------|---------------------------------------------------------------------------------------------------|-----------------|
| AttachedTo | Location of the object this attribute modifies                                                    | Structure array |
| AttachType | Identifies what kind of object this attribute modifies; possible values are 'group' and 'dataset' | Character array |
| Name       | Name to attach to the data set                                                                    | Character array |

`hdf5write(filename, details1, dataset1, details2, dataset2,...)` writes multiple data sets and associated attributes to `filename` in one operation. Each data set and attribute must have an associated `details` structure.

`hdf5write(filename,...,'WriteMode',mode,...)` specifies whether `hdf5write` overwrites the existing file (the default) or appends data sets and attributes to the file. Possible values for `mode` are 'overwrite' and 'append'.

`hdf5write(..., 'V71Dimensions', BOOL)` specifies whether to change the majority of data sets written to the file. If `BOOL` is true, `hdf5write` permutes the first two dimensions of the data set, as it did in previous releases (MATLAB 7.1 [R14SP3] and earlier). This behavior was intended to account for the difference in how HDF5 and MATLAB express array dimensions. HDF5 describes data set dimensions in row-major order; MATLAB stores data in column-major order. However, permuting these dimensions may not correctly reflect the intent of the data and may invalidate metadata. When `BOOL` is false (the default), the data written to the file correctly reflects the data ordering of the data sets — each dimension in the file's data sets matches the same dimension in the corresponding MATLAB variable.

## Data Type Mappings

The following table lists how `hdf5write` maps the data type from the workspace into an HDF5 file. If the data in the workspace that is being written to the file is a MATLAB data type, `hdf5write` uses the following rules when translating MATLAB data into HDF5 data objects.

| <b>MATLAB Data Type</b>    | <b>HDF5 Data Set or Attribute</b>                                                                                                                                                                                                                                                                                                                                                                                                            |
|----------------------------|----------------------------------------------------------------------------------------------------------------------------------------------------------------------------------------------------------------------------------------------------------------------------------------------------------------------------------------------------------------------------------------------------------------------------------------------|
| Numeric                    | Corresponding HDF5 native data type. For example, if the workspace data type is <code>uint8</code> , the <code>hdf5write</code> function writes the data to the file as 8-bit integers. The size of the HDF5 dataspace is the same size as the MATLAB array.                                                                                                                                                                                 |
| String                     | Single, null-terminated string                                                                                                                                                                                                                                                                                                                                                                                                               |
| Cell array of strings      | Multiple, null-terminated strings, each the same length. Length is determined by the length of the longest string in the cell array. The size of the HDF5 dataspace is the same size as the cell array.                                                                                                                                                                                                                                      |
| Cell array of numeric data | Numeric array, the same dimensions as the cell array. The elements of the array must all have the same size and type. The data type is determined by the first element in the cell array.                                                                                                                                                                                                                                                    |
| Structure array            | HDF5 compound type. Individual fields in the structure employ the same data translation rules for individual data types. For example, a cell array of strings becomes a multiple, null-terminated strings.                                                                                                                                                                                                                                   |
| HDF5 objects               | If the data being written to the file is composed of HDF5 objects, <code>hdf5write</code> uses the same data type when writing to the file. For all HDF5 objects, except <code>HDF5.h5enum</code> objects, the dataspace has the same dimensions as the array of HDF5 objects passed to the function. For <code>HDF5.h5enum</code> objects, the size and dimensions of the data set in the HDF5 file is the same as the object's Data field. |

## Examples

Write a 5-by-5 data set of `uint8` values to the root group.

```
hdf5write('myfile.h5', '/dataset1', uint8(magic(5)))
```

# hdf5write

---

Write a 2-by-2 string data set in a subgroup.

```
dataset = {'north', 'south'; 'east', 'west'};
hdf5write('myfile2.h5', '/group1/dataset1.1', dataset);
```

Write a data set and attribute to an existing group.

```
dset = single(rand(10,10));
dset_details.Location = '/group1/dataset1.2';
dset_details.Name = 'Random';

attr = 'Some random data';
attr_details.Name = 'Description';
attr_details.AttachedTo = '/group1/dataset1.2/Random';
attr_details.AttachType = 'dataset';

hdf5write('myfile2.h5', dset_details, dset, ...
 attr_details, attr, 'WriteMode', 'append');
```

Write a data set using objects.

```
dset = hdf5.h5array(magic(5));
hdf5write('myfile3.h5', '/g1/objects', dset);
```

## See Also

[hdf5read](#) | [hdf5info](#)

**Purpose** Gateway to HDF multifile annotation (AN) interface

**Syntax** `[out1,...,outN] = hdfan(funcstr,input1,...,inputN)`

**Description** hdfan is the MATLAB gateway to the HDF multifile annotation (AN) interface.

`[out1,...,outN] = hdfan(funcstr,input1,...,inputN)` returns one or more outputs corresponding to the AN function in the HDF library specified by `funcstr`.

There is a one-to-one correspondence between AN functions in the HDF library and valid values for `funcstr`. For example, `hdfan('endaccess',annot_id)` corresponds to the C library call `ANendaccess(annot_id)`.

### Access Functions

Access functions initialize the interface and provide and terminate access to annotations.

| Value of <code>funcstr</code> | Function Syntax                                                | Description                                                                                                    |
|-------------------------------|----------------------------------------------------------------|----------------------------------------------------------------------------------------------------------------|
| 'start'                       | <code>AN_id = hdfan('start',file_id)</code>                    | Initializes the multifile annotation interface.                                                                |
| 'select'                      | <code>annot_id = hdfan('select',AN_id,index,annot_type)</code> | Selects and returns the identifier for the annotation identified by the given index value and annotation type. |
| 'end'                         | <code>status = hdfan('end',AN_id)</code>                       | Terminates access to the multifile annotation interface.                                                       |

| Value of funcstr | Function Syntax                                                 | Description                                                                                                                           |
|------------------|-----------------------------------------------------------------|---------------------------------------------------------------------------------------------------------------------------------------|
| 'create'         | annot_id =<br>hdfan('create', AN_id, tag, ref, annotation_type) | Creates a data annotation object identified by the specified tag and reference number. annot_type can be 'data_label' or 'data_desc'. |
| 'createf'        | annot_id =<br>hdfan('createf', AN_id, annotation_type)          | Creates a file label annotation. annot_type can be 'file_label' or 'file_desc'.                                                       |
| 'endaccess'      | status =<br>hdfan('endaccess', annot_id)                        | Terminates access to an annotation.                                                                                                   |

## Read/Write Functions

Read/write functions read and write file or object annotations.

| Value of funcstr | Function Syntax                                        | Description                                                             |
|------------------|--------------------------------------------------------|-------------------------------------------------------------------------|
| 'writeann'       | status =<br>hdfan('writeann', annot_id, annotation)    | Writes the annotation corresponding to the given annotation identifier. |
| 'readann'        | [annot_string, status] =<br>hdfan('readann', annot_id) | Reads the annotation corresponding to the given annotation identifier;  |

| Value of funcstr | Function Syntax                                                  | Description                                                                                                                 |
|------------------|------------------------------------------------------------------|-----------------------------------------------------------------------------------------------------------------------------|
|                  | [annot_string,status] = hdfan('readann',annot_id,max_str_length) | Reads the annotation corresponding to the given annotation identifier. annot_string will not be longer than max_str_length. |

## General Inquiry Functions

General inquiry functions return information about the annotations in a file.

| Value of funcstr | Function Syntax                                               | Description                                                                         |
|------------------|---------------------------------------------------------------|-------------------------------------------------------------------------------------|
| 'numann'         | num_annot = hdfan('numann',AN_id,annot_type,tag,ref)          | Gets number of non-modified type corresponding to given tag/ref pair.               |
| 'annlist'        | [ann_list,status] = hdfan('annlist',AN_id,annot_type,tag,ref) | Gets the list of annotation type in the file corresponding to a given tag/ref pair. |
| 'annlen'         | length = hdfan('annlen',annot_id)                             | Gets the length of annotation corresponding to the given annotation identifier.     |

| Value of funcstr | Function Syntax                                            | Description                                                                                                                   |
|------------------|------------------------------------------------------------|-------------------------------------------------------------------------------------------------------------------------------|
| 'fileinfo'       | [nfl,nfd,ndl,ndd,status] =<br>hdfan('fileinfo',AN_id)      | Gets number of file label, file description, data label, and data description annotations in the file corresponding to AN_id. |
| 'get_tagref'     | [tag,ref,status] =<br>hdfan('get_tagref',AN_id,annot_type) | Gets the tag/ref pair for the specified annotation type and index.                                                            |
| 'id2tagref'      | [tag,ref,status] =<br>hdfan('id2tagref',annot_id)          | Gets the tag/ref pair corresponding to the specified annotation identifier.                                                   |
| 'tagref2id'      | annot_id =<br>hdfan('tagref2id',AN_id,tagref)              | Gets the annotation identifier corresponding to the specified tag/ref pair.                                                   |
| 'atype2tag'      | tag =<br>hdfan('atype2tag',annot_type)                     | Gets the tag corresponding to the specified annotation type.                                                                  |
| 'tag2atype'      | annot_type =<br>hdfan('tag2atype',tag)                     | Gets the annotation type corresponding to the specified tag.                                                                  |

## Input/Output Arguments

A status or identifier output of -1 indicates that the operation failed.

In general, the input argument annot\_type can be one of these strings:

- 'file\_label'
- 'file\_desc'



- 'data\_label'
- 'data\_desc'

AN\_id refers to the multifile annotation interface identifier.

annot\_id refers to an individual annotation identifier.

You must terminate access to all opened identifiers using either `hdfan('end',AN_id)` or `hdfan('endaccess',annot_id)`. Otherwise, the HDF library might not properly write all data to the file.

## See Also

[matlab.io.hdf4.sd](#) | [hdfdf24](#) | [hdfdfr8](#) | [hdfh](#) | [hdfhd](#) | [hdfhe](#) | [hdfhx](#) | [hdfml](#) | [hdfv](#) | [hdfvf](#) | [hdfvh](#) | [hdfvs](#)

# hdfdf24

---

**Purpose** Gateway to HDF 24-bit raster image (DF24) interface

**Syntax** `[out1,...,outN] = hdfdf24(funcstr,input1,...,inputN)`

**Description** `hdfdf24` is the MATLAB gateway to the HDF 24-bit raster image interface.

`[out1,...,outN] = hdfdf24(funcstr,input1,...,inputN)` returns one or more outputs corresponding to the DF24 function in the HDF library specified by `funcstr`.

There is a one-to-one correspondence between DF24 functions in the HDF library and valid values for `funcstr`. For example, `hdfdf24('lastref')` corresponds to the C library call `DF24lastref()`.

## Write Functions

Write functions create raster image sets and store them in new files or append them to existing files.

| Value of <code>funcstr</code> | Function Syntax                                          | Description                                                               |
|-------------------------------|----------------------------------------------------------|---------------------------------------------------------------------------|
| 'addimage'                    | <code>status = hdfdf24('addimage',file,image,RGB)</code> | Appends a 24-bit raster image (RGB) file.                                 |
| 'putimage'                    | <code>status = hdfdf24('putimage',file,image,RGB)</code> | Writes a 24-bit raster image (RGB) file by overwriting all existing data. |

| Value of funcstr | Function Syntax                                         | Description                                                                                                                                                                                                                                                                                                                                      |
|------------------|---------------------------------------------------------|--------------------------------------------------------------------------------------------------------------------------------------------------------------------------------------------------------------------------------------------------------------------------------------------------------------------------------------------------|
| 'setcompress'    | status =<br>hdfdf24('setcompress', compress_type, next) | Sets the compress type for the next raster image written to the file. compress_type can be 'none', 'rle', 'jpeg', or 'imcomp'. If compress_type is 'jpeg', then two additional parameters must be specified: quality (a scalar between 0 and 100) and force_baseline (either 0 or 1). Other compression types do not have additional parameters. |
| 'setdims'        | status =<br>hdfdf24('setdims', width, height)           | Sets the dimensions for the next raster image written to the file.                                                                                                                                                                                                                                                                               |
| 'setil'          | status =<br>hdfdf24('setil', interlace)                 | Sets the interlace format for the next raster image written to the file. interlace can be 'pixel', 'line', or 'component'.                                                                                                                                                                                                                       |
| 'lastref'        | ref =<br>hdfdf24('lastref')                             | Reports the last reference number assigned to a 24-bit raster image.                                                                                                                                                                                                                                                                             |

## Read Functions

Read functions determine the dimensions and interlace format of an image set, read the actual image data, and provide sequential or random read access to any raster image set.

| Value of funcstr | Function Syntax                                                  | Description                                                                                                    |
|------------------|------------------------------------------------------------------|----------------------------------------------------------------------------------------------------------------|
| 'getdims'        | [width,height,interlace,status] =<br>hdfdf24('getdims',filename) | Returns the dimensions before reading the next raster image. interlace can be 'pixel', 'line', or 'component'. |
| 'getimage'       | [RGB,status] =<br>hdfdf24('getimage',filename)                   | Reads the next 24-bit raster image.                                                                            |
| 'reqil'          | status =<br>hdfdf24('reqil',interlace)                           | Specifies the interlace format before reading the next raster image. interlace can be                          |
| 'readref'        | status =<br>hdfdf24('readref',filename,raster)                   | Reads 24-bit raster image with the specified raster number.                                                    |
| 'restart'        | status =<br>hdfdf24('restart')                                   | Returns to the first 24-bit raster image in the file.                                                          |
| 'nimages'        | num_images =<br>hdfdf24('nimages',filename)                      | Reports the number of 24-bit raster images in a file.                                                          |

## Input/Output Arguments

A status or identifier output of -1 indicates that the operation failed.

HDF uses C-style ordering of elements, in which elements along the last dimension vary fastest. MATLAB uses FORTRAN-style ordering, in which elements along the first dimension vary fastest. hdfdf24

does not automatically convert from C-style ordering to MATLAB style ordering, which means that MATLAB image arrays need to be permuted when using `hdfdf24` to read or write from HDF files. The exact permutation depends on the interlace format specified by, for example, `hdfdf24('setil', ...)`. The following calls to `permute` converts HDF arrays to MATLAB arrays, according to the specified interlace format.

```
RGB = permute(RGB,[3 2 1]); 'pixel' interlace
RGB = permute(RGB,[3 1 2]); 'line' interlace
RGB = permute(RGB,[2 1 3]); 'component' interlace
```

## See Also

[matlab.io.hdf4.sd](#) | [hdfdf24](#) | [hdfdf8](#) | [hdfh](#) | [hdfhd](#) | [hdfhe](#) | [hdfhx](#) | [hdfml](#) | [hdfv](#) | [hdfvf](#) | [hdfvh](#) | [hdfvs](#)

# hdfdf8

**Purpose** Gateway to HDF 8-bit raster image (DFR8) interface

**Syntax** `[out1,...,outN] = hdfdf8(funcstr,input1,...,inputN)`

**Description** `hdfdf8` is the MATLAB gateway to the HDF 8-bit raster image (DFR8) interface.

`[out1,...,outN] = hdfdf8(funcstr,input1,...,inputN)` returns one or more outputs corresponding to the DFR8 function in the HDF library specified by `funcstr`.

There is a one-to-one correspondence between DFR8 functions in the HDF library and valid values for `funcstr`. For example, `hdfdf8('setpalette',map)` corresponds to the C library call `DFR8setpalette(map)`.

## Write Functions

Write functions create raster image sets and store them in new files or append them to existing files.

| Value of <code>funcstr</code> | Function Syntax                                            | Description                                                                                                               |
|-------------------------------|------------------------------------------------------------|---------------------------------------------------------------------------------------------------------------------------|
| 'writeref'                    | <code>status = hdfdf8('writeref',filename,ref)</code>      | Stores the raster image <code>name, ref</code> specified reference number.                                                |
| 'setpalette'                  | <code>status = hdfdf8('setpalette',color,images)</code>    | Sets palette for multiple color raster images.                                                                            |
| 'addimage'                    | <code>status = hdfdf8('addimage',filename,compress)</code> | Appends an 8-bit raster image to <code>filename</code> . <code>compress</code> can be 'none', 'rle', 'jpeg', or 'imcomp'. |

| Value of funcstr | Function Syntax                                                        | Description                                                                                                                                                                                                                                                                                           |
|------------------|------------------------------------------------------------------------|-------------------------------------------------------------------------------------------------------------------------------------------------------------------------------------------------------------------------------------------------------------------------------------------------------|
| 'putimage'       | status = hdfdf8('putimage', filename, compress)                        | Writes an 8-bit raster image to a file or creates the file. compress can be 'none', 'rle', 'jpeg', or 'imcomp'.                                                                                                                                                                                       |
| 'setcompress'    | status = hdfdf8('setcompress', compress_type, quality, force_baseline) | Sets the compression type. compress_type can be 'none', 'rle', 'jpeg', or 'imcomp'. If compress_type is 'jpeg', then two additional parameters must be passed in: quality (a scalar between 0 and 100) and force_baseline (either 0 or 1). Other compression types do not have additional parameters. |

### Read Functions

Read functions determine the dimension and palette assignment for an image set, read the actual image data, and provide sequential or random read access to any raster image set.

| Value of funcstr | Function Syntax                                              | Description                                                               |
|------------------|--------------------------------------------------------------|---------------------------------------------------------------------------|
| 'getdims'        | [width,height,hasmap,status] =<br>hdfdf8('getdims',filename) | Returns dimensions for an 8-bit raster image.                             |
| 'getimage'       | [X,map,status] =<br>hdfdf8('getimage',filename)              | Retrieves an 8-bit raster image and its palette.                          |
| 'readref'        | status =<br>hdfdf8('readref',filename)                       | Gets the next raster image with the specified reference number.           |
| 'restart'        | status =<br>hdfdf8('restart')                                | Ignores information about last file accessed and restarts from beginning. |
| 'nimages'        | num_images =<br>hdfdf8('nimages',filename)                   | Returns number of raster images in a file.                                |
| 'lastref'        | ref =<br>hdfdf8('lastref')                                   | Returns reference number of last element accessed.                        |

## Input/Output Arguments

A status or identifier output of -1 indicates that the operation failed.

HDF uses C-style ordering of elements, in which elements along the last dimension vary fastest. MATLAB uses FORTRAN-style ordering, in which elements along the first dimension vary fastest. `hdfdf8` does not automatically convert from C-style ordering to MATLAB style ordering, which means that MATLAB image and colormap matrices must be transposed when using `hdfdf8` to read or write from HDF files.

Functions in `hdfdf8` that read and write palette information expect to use `uint8` data in the range [0,255], while MATLAB colormaps contain double-precision values in the range [0,1]. Therefore, HDF palettes must be converted to `double` and scaled to be used as MATLAB colormaps.



## See Also

[matlab.io.hdf4.sd](#) | [hdfdf24](#) | [hdfdf8](#) | [hdfh](#) | [hdfhd](#) | [hdfhe](#) | [hdfhx](#) | [hdfml](#) | [hdfv](#) | [hdfvf](#) | [hdfvh](#) | [hdfvs](#)

**Purpose** Gateway to HDF H interface

**Syntax** [out1,...,outN] = hdfh(funcstr,input1,...,inputN)

**Description** hdfh is the MATLAB gateway to the HDF H interface.

[out1,...,outN] = hdfh(funcstr,input1,...,inputN) returns one or more outputs corresponding to the H function in the HDF library specified by funcstr.

There is a one-to-one correspondence between H functions in the HDF library and valid values for funcstr. For example, hdfh('close',file\_id) corresponds to the C library call Hclose(file\_id).

## Functions

| Value of funcstr | Function Syntax                                                          | Description                                                               |
|------------------|--------------------------------------------------------------------------|---------------------------------------------------------------------------|
| 'appendable'     | status =<br>hdfh('appendable',access_id)                                 | Specifies that the element can be appended to.                            |
| 'close'          | status =<br>hdfh('close',file_id)                                        | Closes the access path to the file.                                       |
| 'delidd'         | status =<br>hdfh('delidd',file_id,tag,ref)                               | Deletes a tag and reference number from the data descriptor list.         |
| 'dupdd'          | status =<br>hdfh('dupdd',file_id,tag,ref,old_tag,old_ref)                |                                                                           |
| 'endaccess'      | status =<br>hdfh('endaccess',access_id)                                  | Terminates access to a data object by disposing of the access identifier. |
| 'fidinquire'     | [filename,access_mode,attributes,status] =<br>hdfh('fidinquire',file_id) | Returns information about specified file.                                 |

| Value of funcstr | Function Syntax                                                                                          | Description                                                                                                                                      |
|------------------|----------------------------------------------------------------------------------------------------------|--------------------------------------------------------------------------------------------------------------------------------------------------|
| 'find'           | [tag,ref,offset,length,status] =<br>hdfh('find',file_id,...<br>search_tag,search_ref,search_type,newref) | Locates the next object to be searched for in an HDF file. search_type can be 'new' or 'continue'. The dir input can be 'forward' or 'backward'. |
| 'getelement'     | [data,status] =<br>hdfh('getelement',file_id,tag,ref)                                                    | Reads the data element for the specified tag and reference number.                                                                               |
| 'getfileversion' | [major,minor,release,info,status] =<br>hdfh('getfileversion',file_id)                                    | [Status] version information for an HDF file.                                                                                                    |
| 'getlibversion'  | [major,minor,release,info,status] =<br>hdfh('getlibversion')                                             | [Status] version information for the current HDF library.                                                                                        |
| 'inquire'        | [file_id,tag,ref,length,offset,position,access,...<br>special,status] =<br>hdfh('inquire',access_id)     | Retrieves information about a data element.                                                                                                      |
| 'ishdf'          | tf =<br>hdfh('ishdf',filename)                                                                           | Determines if a file is an HDF file.                                                                                                             |
| 'length'         | length =<br>hdfh('length',file_id,tag,ref)                                                               | Returns the length of a data object specified by the tag and reference number.                                                                   |
| 'newref'         | ref =<br>hdfh('newref',file_id)                                                                          | Returns a reference number that can be used with any tag to product a unique tag/reference number pair.                                          |

| Value of funcstr | Function Syntax                                               | Description                                                                                                                     |
|------------------|---------------------------------------------------------------|---------------------------------------------------------------------------------------------------------------------------------|
| 'nextread'       | status =<br>hdfh('nextread',access_id,tag,description,origin) | Searches for the next tag, description that matches the specified tag and reference number. origin can be 'start' or 'current'. |
| 'number'         | num =<br>hdfh('number',file_id,tag)                           | Returns the number of instances of a tag in a file.                                                                             |
| 'offset'         | offset =<br>hdfh('offset',file_id,tag,data)                   | Returns the offset of a data element in the file.                                                                               |
| 'open'           | file_id =<br>hdfh('open',filename,access_id)                  | Provides an access path to an HDF file by reading all the data descriptor blocks into memory.                                   |
| 'putelement'     | count =<br>hdfh('putelement',file_id,tag,ref,X)               | Writes a data element (tag,ref,X) an existing data element in an HDF file. X must be a uint8 array.                             |
| 'read'           | X =<br>hdfh('read',access_id,length)                          | Reads the next segment (tag) data element.                                                                                      |
| 'seek'           | status =<br>hdfh('seek',access_id,offset,origin)              | Sets the access pointer (tag,offset) within a data element. origin can be 'start' or 'current'.                                 |
| 'startread'      | access_id =<br>hdfh('startread',file_id,tag,ref)              |                                                                                                                                 |

| Value of funcstr | Function Syntax                                          | Description                                                                        |
|------------------|----------------------------------------------------------|------------------------------------------------------------------------------------|
| 'startwrite'     | access_id =<br>hdfh('startwrite',file_id,tag,ref,length) |                                                                                    |
| 'sync'           | status =<br>hdfh('sync',file_id)                         |                                                                                    |
| 'trunc'          | length =<br>hdfh('trunc',access_id,truncateobj)          | Truncates the specified data element to the given length.                          |
| 'write'          | count =<br>hdfh('write',access_id,X)                     | Writes the next data segment to a specified data element. X must be a uint8 array. |

### Output Arguments

A status or identifier output of -1 indicates that the operation failed.

### Limitations

- hdfh does not support these functions in the NCSA H interface:
  - Hcache
  - Hendbitaccess
  - Hexist
  - Hflushdd
  - Hgetbit
  - Hputbit
  - Hsetlength
  - Hshutdown
  - Htagnewref

### See Also

matlab.io.hdf4.sd | hdfan | hfd24 | hfdfr8 | hfdhd | hfdhe | hfdhx | hfdml | hfdv | hfdvf | hfdvh | hfdvs

# hdfhd

---

**Purpose** Gateway to HDF HD interface

**Syntax** `[out1,...,outN] = hdfhd(funcstr,input1,...,inputN)`

**Description** hdfhd is the MATLAB gateway to the HDF HD interface.

`[out1,...,outN] = hdfhd(funcstr,input1,...,inputN)` returns one or more outputs corresponding to the HD function in the HDF library specified by `funcstr`.

There is a one-to-one correspondence between HD functions in the HDF library and valid values for `funcstr`.

## Functions

| Value of <code>funcstr</code> | Function Syntax                                  | Description                         |
|-------------------------------|--------------------------------------------------|-------------------------------------|
| 'gettagsname'                 | <code>tag_name = hdfhd('gettagsname',tag)</code> | Gets the name of the specified tag. |

## Output Arguments

A status or identifier output of -1 indicates that the operation failed.

## See Also

`matlab.io.hdf4.sd` | `hdfan` | `hdfdf24` | `hdfdf8` | `hdfh` | `hdfhd` | `hdfhe` | `hdfml` | `hdfv` | `hdfvf` | `hdfvh` | `hdfvs`

**Purpose** Gateway to HDF HE interface

**Syntax** `[out1,...,outN] = hdfhe(funcstr,input1,...,inputN)`

**Description** hdfhe is the MATLAB gateway to the HDF HE interface.

This is a stub page.

`[out1,...,outN] = hdfhe(funcstr,input1,...,inputN)` returns one or more outputs corresponding to the HE function in the HDF library specified by `funcstr`.

There is a one-to-one correspondence between HE functions in the HDF library and valid values for `funcstr`.

### Functions

| Value of <code>funcstr</code> | Function Syntax                                         | Description                                                                                                                                |
|-------------------------------|---------------------------------------------------------|--------------------------------------------------------------------------------------------------------------------------------------------|
| 'clear'                       | <code>hdfhe('clear')</code>                             | Clears all information on reported errors from the error stack.                                                                            |
| 'print'                       | <code>hdfhe('print',level)</code>                       | Prints information in error stack. If <code>level</code> is 0, then the entire error stack is printed.                                     |
| 'string'                      | <code>error_text = hdfhe('string',error_message)</code> | Returns the error message associated with the specified error code.                                                                        |
| 'value'                       | <code>error_code = hdfhe('value',stack_offset)</code>   | Returns an error code from the specified level of the error stack. A <code>stack_offset</code> value of 1 gets the most recent error code. |

# hdfhe

---

## Output Arguments

A status or identifier output of -1 indicates that the operation failed.

## Limitations

- hdfhe does not support these functions:
  - HEpush
  - HReport

## See Also

[matlab.io.hdf4.sd](#) | [hdfan](#) | [hdfdf24](#) | [hdfdf8](#) | [hdfh](#) | [hdfhd](#) | [hdfhe](#) | [hdfml](#) | [hdfv](#) | [hdfvf](#) | [hdfvh](#) | [hdfvs](#)



**Purpose** Gateway to HDF external data (HX) interface

**Syntax** `[out1,...,outN] = hdfhx(funcstr,input1,...,inputN)`

**Description** hdfhx is the MATLAB gateway to the HDF interface for manipulating linked and external data elements.

`[out1,...,outN] = hdfhx(funcstr,input1,...,inputN)` returns one or more outputs corresponding to the HX function in the HDF library specified by `funcstr`.

There is a one-to-one correspondence between HX functions in the HDF library and valid values for `funcstr`. For example, `hdfhx('setdir',pathname)`; corresponds to the C library call `HXsetdir(pathname)`.

### Functions

| Value of funcstr | Function Syntax                                                                       | Description                                                                                                                        |
|------------------|---------------------------------------------------------------------------------------|------------------------------------------------------------------------------------------------------------------------------------|
| 'create'         | <code>access_id = hdfhx('create',file_id,filespec,external_name,offset,length)</code> | Creates a new external file.                                                                                                       |
| 'setcreatedir'   | <code>status = hdfhx('setcreatedir',pathname)</code>                                  | Sets the directory <code>pathname</code> for writing external file.                                                                |
| 'setdir'         | <code>status = hdfhx('setdir',pathname)</code>                                        | Sets the directory for locating external files. <code>pathname</code> can contain multiple directories separated by vertical bars. |

### Input/Output Arguments

A `status` or identifier output of -1 indicates that the operation failed.

In cases where the HDF C library accepts NULL for certain inputs, an empty matrix (`[]` or `''`) can be used.

# hdfhx

---

## See Also

[matlab.io.hdf4.sd](#) | [hdfan](#) | [hdfdf24](#) | [hdfdf8](#) | [hdfh](#) | [hdfhd](#) | [hdfhe](#) | [hdfml](#) | [hdfv](#) | [hdfvf](#) | [hdfvh](#) | [hdfvs](#)

**Purpose** Information about HDF4 or HDF-EOS file

**Syntax**  
 S = hdfinfo(filename)  
 S = hdfinfo(filename,mode)

**Description** S = hdfinfo(filename) returns a structure S whose fields contain information about the contents of an HDF4 or HDF-EOS file. filename is a string that specifies the name of the HDF4 file.

S = hdfinfo(filename,mode) reads the file as an HDF4 file, if mode is 'hdf', or as an HDF-EOS file, if mode is 'eos'. If mode is 'eos', only HDF-EOS data objects are queried. To retrieve information on the entire contents of a file containing both HDF4 and HDF-EOS objects, mode must be 'hdf'.

---

**Note** hdfinfo can be used on Version 4.x HDF files or Version 2.x HDF-EOS files. To get information about an HDF5 file, use hdf5info.

---

The set of fields in the returned structure S depends on the individual file. Fields that can be present in the S structure are shown in the following table.

| Mode | Field Name  | Description                        | Return Type     |
|------|-------------|------------------------------------|-----------------|
| HDF  | Attributes  | Attributes of the data set         | Structure array |
|      | Description | Annotation description             | Cell array      |
|      | Filename    | Name of the file                   | String          |
|      | Label       | Annotation label                   | Cell array      |
|      | Raster8     | Description of 8-bit raster images | Structure array |

| Mode | Field Name | Description                         | Return Type     |
|------|------------|-------------------------------------|-----------------|
|      | Raster24   | Description of 24-bit raster images | Structure array |
|      | SDS        | Description of scientific data sets | Structure array |
|      | Vdata      | Description of Vdata sets           | Structure array |
|      | Vgroup     | Description of Vgroups              | Structure array |
| EOS  | Filename   | Name of the file                    | String          |
|      | Grid       | Grid data                           | Structure array |
|      | Point      | Point data                          | Structure array |
|      | Swath      | Swath data                          | Structure array |

Those fields in the table above that contain structure arrays are further described in the tables shown below.

## Fields Common to Returned Structure Arrays

Structure arrays returned by `hdfinfo` contain some common fields. These are shown in the table below. Not all structure arrays will contain all of these fields.

| Field Name  | Description                                          | Data Type       |
|-------------|------------------------------------------------------|-----------------|
| Attributes  | Data set attributes. Contains fields Name and Value. | Structure array |
| Description | Annotation description                               | Cell array      |
| Filename    | Name of the file                                     | String          |
| Label       | Annotation label                                     | Cell array      |

| Field Name | Description                          | Data Type |
|------------|--------------------------------------|-----------|
| Name       | Name of the data set                 | String    |
| Rank       | Number of dimensions of the data set | Double    |
| Ref        | Data set reference number            | Double    |
| Type       | Type of HDF or HDF-EOS object        | String    |

## Fields Specific to Certain Structures

Structure arrays returned by `hdinfo` also contain fields that are unique to each structure. These are shown in the tables below.

### Fields of the Attribute Structure

| Field Name | Description                    | Data Type         |
|------------|--------------------------------|-------------------|
| Name       | Attribute name                 | String            |
| Value      | Attribute value or description | Numeric or string |

### Fields of the Raster8 and Raster24 Structures

| Field Name | Description                                                                       | Data Type |
|------------|-----------------------------------------------------------------------------------|-----------|
| HasPalette | 1 (true) if the image has an associated palette, otherwise 0 (false) (8-bit only) | Logical   |
| Height     | Height of the image, in pixels                                                    | Number    |
| Interlace  | Interlace mode of the image (24-bit only)                                         | String    |
| Name       | Name of the image                                                                 | String    |
| Width      | Width of the image, in pixels                                                     | Number    |

## Fields of the SDS Structure

| Field Name | Description                                                                                                                                                                                 | Data Type       |
|------------|---------------------------------------------------------------------------------------------------------------------------------------------------------------------------------------------|-----------------|
| DataType   | Data precision                                                                                                                                                                              | String          |
| Dims       | Dimensions of the data set. Contains fields Name, DataType, Size, Scale, and Attributes. Scale is an array of numbers to place along the dimension and demarcate intervals in the data set. | Structure array |
| Index      | Index of the SDS                                                                                                                                                                            | Number          |

## Fields of the Vdata Structure

| Field Name     | Description                                                        | Data Type       |
|----------------|--------------------------------------------------------------------|-----------------|
| DataAttributes | Attributes of the entire data set. Contains fields Name and Value. | Structure array |
| Class          | Class name of the data set                                         | String          |
| Fields         | Fields of the Vdata. Contains fields Name and Attributes.          | Structure array |
| NumRecords     | Number of data set records                                         | Double          |
| IsAttribute    | 1 (true) if Vdata is an attribute, otherwise 0 (false)             | Logical         |

## Fields of the Vgroup Structure

| Field Name | Description                             | Data Type       |
|------------|-----------------------------------------|-----------------|
| Class      | Class name of the data set              | String          |
| Raster8    | Description of the 8-bit raster image   | Structure array |
| Raster24   | Description of the 24-bit raster image  | Structure array |
| SDS        | Description of the Scientific Data sets | Structure array |
| Tag        | Tag of this Vgroup                      | Number          |
| Vdata      | Description of the Vdata sets           | Structure array |
| Vgroup     | Description of the Vgroups              | Structure array |

## Fields of the Grid Structure

| Field Name  | Description                                                                                                                           | Data Type       |
|-------------|---------------------------------------------------------------------------------------------------------------------------------------|-----------------|
| Columns     | Number of columns in the grid                                                                                                         | Number          |
| DataFields  | Description of the data fields in each Grid field of the grid. Contains fields Name, Rank, Dims, NumberType, FillValue, and TileDims. | Structure array |
| LowerRight  | Lower right corner location, in meters                                                                                                | Number          |
| Origin Code | Origin code for the grid                                                                                                              | Number          |
| PixRegCode  | Pixel registration code                                                                                                               | Number          |

## Fields of the Grid Structure (Continued)

| Field Name | Description                                                                                                                                    | Data Type |
|------------|------------------------------------------------------------------------------------------------------------------------------------------------|-----------|
| Projection | Projection code, zone code, sphere code, and projection parameters of the grid. Contains fields ProjCode, ZoneCode, SphereCode, and ProjParam. | Structure |
| Rows       | Number of rows in the grid                                                                                                                     | Number    |
| UpperLeft  | Upper left corner location, in meters                                                                                                          | Number    |

## Fields of the Point Structure

| Field Name | Description                                                                                                | Data Type |
|------------|------------------------------------------------------------------------------------------------------------|-----------|
| Level      | Description of each level of the point. Contains fields Name, NumRecords, FieldNames, DataType, and Index. | Structure |

## Fields of the Swath Structure

| Field Name        | Description                                                                            | Data Type       |
|-------------------|----------------------------------------------------------------------------------------|-----------------|
| DataFields        | Data fields in the swath. Contains fields Name, Rank, Dims, NumberType, and FillValue. | Structure array |
| GeolocationFields | Geolocation fields in the swath. Contains fields Name,                                 | Structure array |



**Fields of the Swath Structure (Continued)**

| Field Name | Description                                                                                     | Data Type |
|------------|-------------------------------------------------------------------------------------------------|-----------|
|            | Rank, Dims, NumberType, and FillValue.                                                          |           |
| IdxMapInfo | Relationship between indexed elements of the geolocation mapping. Contains fields Map and Size. | Structure |
| MapInfo    | Relationship between data and geolocation fields. Contains fields Map, Offset, and Increment.   | Structure |

**Examples**

To retrieve information about the file `example.hdf`,

```
fileinfo = hdfinfo('example.hdf')
```

```
fileinfo =
 Filename: 'example.hdf'
 SDS: [1x1 struct]
 Vdata: [1x1 struct]
```

And to retrieve information from this about the scientific data set in `example.hdf`,

```
sds_info = fileinfo.SDS

sds_info =
 Filename: 'example.hdf'
 Type: 'Scientific Data Set'
 Name: 'Example SDS'
 Rank: 2
 DataType: 'int16'
 Attributes: []
```

# hdfinfo

---

```
 Dims: [2x1 struct]
 Label: {}
 Description: {}
 Index: 0
```

## See Also

[hdfread](#)

|                    |                                                                                                                                                                                                                                                                                                                                                                                                                                                                                                                                                                                                                                                                                                                                                                                                                                                                                                                                                                                                                                                                                                       |
|--------------------|-------------------------------------------------------------------------------------------------------------------------------------------------------------------------------------------------------------------------------------------------------------------------------------------------------------------------------------------------------------------------------------------------------------------------------------------------------------------------------------------------------------------------------------------------------------------------------------------------------------------------------------------------------------------------------------------------------------------------------------------------------------------------------------------------------------------------------------------------------------------------------------------------------------------------------------------------------------------------------------------------------------------------------------------------------------------------------------------------------|
| <b>Purpose</b>     | Utilities for working with MATLAB HDF gateway functions                                                                                                                                                                                                                                                                                                                                                                                                                                                                                                                                                                                                                                                                                                                                                                                                                                                                                                                                                                                                                                               |
| <b>Syntax</b>      | <pre>hdfml('closeall') hdfml('listinfo') tag = hdfml('tagnum',tagname) nbytes = hdfml('sizeof',data_type) hdfml('defaultchartype',char_type)</pre>                                                                                                                                                                                                                                                                                                                                                                                                                                                                                                                                                                                                                                                                                                                                                                                                                                                                                                                                                    |
| <b>Description</b> | <p><code>hdfml('closeall')</code> closes all open registered HDF file and data object identifiers.</p> <p><code>hdfml('listinfo')</code> prints information about all open registered HDF file and data object identifiers.</p> <p><code>tag = hdfml('tagnum',tagname)</code> returns the tag number corresponding to the tag name specified by <code>tagname</code>.</p> <p><code>nbytes = hdfml('sizeof',data_type)</code> returns size in bytes of specified data type.</p> <p><code>hdfml('defaultchartype',char_type)</code> defines the HDF data type for MATLAB strings. Valid values for <code>char_type</code> are 'char8' or 'uchar8'. The change persists until the MATLAB HDF gateway function is cleared from memory. MATLAB strings are mapped to char8 by default.</p> <p>The MATLAB HDF gateway functions maintain lists of certain HDF file and data object identifiers so that, for example, HDF objects and files can be properly closed when a user issues the command:</p> <pre>clear mex</pre> <p>These lists are updated whenever these identifiers are created or closed.</p> |
| <b>See Also</b>    | <a href="#">matlab.io.hdf4.sd</a>   <a href="#">hdfan</a>   <a href="#">hdfdf24</a>   <a href="#">hdfdf8</a>   <a href="#">hdfh</a>   <a href="#">hdfhd</a>   <a href="#">hdfhe</a>   <a href="#">hdfml</a>   <a href="#">hdfv</a>   <a href="#">hdfvf</a>   <a href="#">hdfvh</a>   <a href="#">hdfvs</a>                                                                                                                                                                                                                                                                                                                                                                                                                                                                                                                                                                                                                                                                                                                                                                                            |

# hdfpt

---

**Purpose** Interface to HDF-EOS Point object

**Syntax** `[out1,...,outN] = hdfpt(funcstr,input1,...,inputN)`

**Description** `hdfpt` is the MATLAB gateway to the Point functions in the HDF-EOS C library, which is developed and maintained by EOSDIS (Earth Observing System Data and Information System). A Point data set comprises a series of data records taken at (possibly) irregular time intervals and at scattered geographic locations. Each data record consists of a set of one or more data values representing the state of a point in time and/or space.

`[out1,...,outN] = hdfpt(funcstr,input1,...,inputN)` returns one or more outputs corresponding to the Point function in the HDF-EOS library specified by `funcstr`.

There is a one-to-one correspondence between PT functions in the HDF-EOS C library and valid values for `funcstr`. For example, `hdfpt('detach',point_id)` corresponds to the C library call `PTdetach(point_id)`.

## Programming Model

The programming model for accessing a point data set through `hdfpt` is as follows:

- 1 Open the file and initialize the PT interface by obtaining a file id from a file name.
- 2 Open or create a point data set by obtaining a point id from a point name.
- 3 Perform desired operations on the data set.
- 4 Close the point data set by disposing of the point id.
- 5 Terminate point access to the file by disposing of the file id.

To access a single point data set that already exists in an HDF-EOS file, use the following MATLAB commands:

```
fileid = hdfpt('open',filename,access);
pointid = hdfpt('attach',fileid,pointname);

% Optional operations on the data set...

status = hdfpt('detach',pointid);
status = hdfpt('close',fileid);
```

To access several files at the same time, obtain a separate file identifier for each file to be opened. To access more than one point data set, obtain a separate point id for each data set.

It is important to properly dispose of point id's and file id's so that buffered operations are written completely to disk. If you quit MATLAB or clear all MEX-files with PT identifiers still open, MATLAB issues a warning and automatically disposes of them.

Note that file identifiers returned by `hdfpt` are not interchangeable with file identifiers returned by any other HDF-EOS or HDF function.

### **Access Routines**

Access routines initialize and terminate access to the PT interface and point data sets (including opening and closing files).

| Value of funcstr | Function Syntax                                 | Description                                                                                                                                                                                        |
|------------------|-------------------------------------------------|----------------------------------------------------------------------------------------------------------------------------------------------------------------------------------------------------|
| 'open'           | file_id =<br>hdfpt('open',filename,access)      | Given the filename and access mode, opens or creates an HDF file in order to create, read, or write a point. access can be 'read', 'readwrite', or 'create'. file_id is -1 if the operation fails. |
| 'create'         | point_id =<br>hdfpt('create',file_id,pointname) | Creates a point data set with the specified name. pointname is a string contain the name of the point data set. point_id is -1 if the operation fails.                                             |
| 'attach'         | point_id =<br>hdfpt('attach',file_id,pointname) | Attaches to an existing point data set within the file. point_id is -1 if the operation fails.                                                                                                     |
| 'detach'         | status =<br>hdfpt('detach',point_id)            | Detaches from point data set.                                                                                                                                                                      |
| 'close'          | status =<br>hdfpt('close',file_id)              | Closes file.                                                                                                                                                                                       |

## Definition Routines

Definition routines allow the user to set key features of a point data set.

| Value of funcstr | Function Syntax                                                                  | Description                                                                                                                                                                                                                                                                                                                                                                                                                                                                  |
|------------------|----------------------------------------------------------------------------------|------------------------------------------------------------------------------------------------------------------------------------------------------------------------------------------------------------------------------------------------------------------------------------------------------------------------------------------------------------------------------------------------------------------------------------------------------------------------------|
| 'deflevel'       | status = hdfpt('deflevel',point,levelName,data fieldList,fieldTypes,fieldOrders) | Defines a new level within a point. levelName is the name of the level to be defined. fieldList is a string containing a comma-separated list of field names in the new level. fieldTypes is a cell array containing the number type string for each field. Valid number type strings include 'uchar8', 'uchar', 'char8', 'char', 'double', 'uint8', 'uint16', 'uint32', 'float', 'int8', 'int16', and 'int32'. fieldOrders is a vector containing the order for each field. |
| 'deflinkage'     | status = hdfpt('deflinkage',point,parent,child,linkfield)                        | Defines a linkfield between two adjacent levels. parent is the name of the parent level. child is the name of the child level. linkfield is the name of a field that is defined at both levels.                                                                                                                                                                                                                                                                              |

**Basic I/O Routines**

Basic I/O routines read and write data and metadata to a point data set.

| Value of funcstr | Function Syntax                                                             | Description                                                                                                                                                                                                                                                                                                                                                                                                                                                                                                                                                                                                                                               |
|------------------|-----------------------------------------------------------------------------|-----------------------------------------------------------------------------------------------------------------------------------------------------------------------------------------------------------------------------------------------------------------------------------------------------------------------------------------------------------------------------------------------------------------------------------------------------------------------------------------------------------------------------------------------------------------------------------------------------------------------------------------------------------|
| 'writelevel'     | <pre>status = hdfpt('writelevel',point,level,data)</pre>                    | <p>Appends new records to the specified level in a point data set. <b>level</b> is the desired level index (zero-based). <b>data</b> must be a P-by-1 cell array where <b>P</b> is the number of fields defined for the specified level. Each cell of <b>data</b> must contain an M(k)-by-N matrix of data, where M(k) is the order of the k-th field (the number of scalar values in the field) and N is the number of records. The MATLAB class of the cells must match the HDF data type defined for the corresponding fields. A MATLAB string is automatically converted to match any of the HDF char types. Other data types must match exactly.</p> |
| 'readlevel'      | <pre>[data,status] = hdfpt('readlevel',point,level,fieldList,records)</pre> | <p>Reads data from a given level in a point data set. <b>level</b> is the index (zero-based) of the desired level. <b>fieldList</b> is a string containing a comma-separated list of the fields to read.</p>                                                                                                                                                                                                                                                                                                                                                                                                                                              |





| Value of funcstr | Function Syntax                                      | Description                                                                                                                                                                                                                                                                                   |
|------------------|------------------------------------------------------|-----------------------------------------------------------------------------------------------------------------------------------------------------------------------------------------------------------------------------------------------------------------------------------------------|
|                  |                                                      | values in the field) and N is the number of records, or length(records). The MATLAB class of the cells must match the HDF data type defined for the corresponding fields. A MATLAB string is automatically converted to match any of the HDF char types. Other data types must match exactly. |
| 'writeattr'      | status = hdfpt('writeattr',point_id,attribute,data)  | Writes or updates the attribute with the specified name. If the attribute does not already exist, it is created.                                                                                                                                                                              |
| 'readattr'       | [data,status] = hdfpt('readattr',point_id,attribute) | Reads the attribute data from the specified attribute.                                                                                                                                                                                                                                        |

## Inquiry Routines

Inquiry routines return information about data contained in a point data set.

| Value of funcstr | Function Syntax                                                                          | Description                                                                                                                                                                                                                                                                                                                        |
|------------------|------------------------------------------------------------------------------------------|------------------------------------------------------------------------------------------------------------------------------------------------------------------------------------------------------------------------------------------------------------------------------------------------------------------------------------|
| 'nlevels'        | nlevels =<br>hdfpt('nlevels',point_id)                                                   | Returns the number of levels in a point data set. nlevels is -1 if the operation fails.                                                                                                                                                                                                                                            |
| 'nrecs'          | nrecs =<br>hdfpt('nrecs',point_id,level)                                                 | Returns the number of records in the specified level. nrecs is -1 if the operation fails.                                                                                                                                                                                                                                          |
| 'nfields'        | [numfields,strbufsize] =<br>hdfpt('nfields',point_id,level,strbufsize)                   | Returns the number of fields in the specified level. strbufsize is the length of the comma-separated field name string. numfields is -1 and strbufsize is [] if the operation fails.                                                                                                                                               |
| 'levelinfo'      | [numfields,fieldList,fieldType,fieldOrder] =<br>...<br>hdfpt('levelinfo',point_id,level) | Returns information on fields for a specified level. fieldList is a comma-separated list of field names. fieldType is a cell array of strings that defined the data type for each field. fieldOrder is a vector containing the order (number of scalar values) associated with each field. If the operation fails, numfields is -1 |

| Value of funcstr | Function Syntax                                           | Description                                                                                                    |
|------------------|-----------------------------------------------------------|----------------------------------------------------------------------------------------------------------------|
|                  |                                                           | and the other outputs are empty.                                                                               |
| 'levelindx'      | level = hdfpt('levelindx',point(zero-based))              | Returns the level index (zero-based) of the level with the specified name. level is -1 if the operation fails. |
| 'bcklinkinfo'    | [linkfield,status] = hdfpt('bcklinkinfo',point(the prev)) | Returns the linkfield to the previous level. status is -1 and linkfield is [] if the operation fails.          |
| 'fwdlinkinfo'    | [linkfield,status] = hdfpt('fwdlinkinfo',point(follow))   | Returns the linkfield to the following level. status is -1 and linkfield is [] if the operation fails.         |
| 'getlevelname'   | [levelname,status] = hdfpt('getlevelname',point(level))   | Returns the name of the level index. status is -1 and levelname is [] if the operation fails.                  |

| Value of funcstr | Function Syntax                                                                | Description                                                                                                                                                                                                                                                                                                                                                      |
|------------------|--------------------------------------------------------------------------------|------------------------------------------------------------------------------------------------------------------------------------------------------------------------------------------------------------------------------------------------------------------------------------------------------------------------------------------------------------------|
| 'sizeof'         | <pre>[byteSize,fieldLevels] = hdfpt('sizeof',point_id,fieldList)</pre>         | <p>Returns the size in bytes and field levels of the specified fields. fieldList is a string containing a comma-separated list of field names. byteSize is the total size of bytes of the specified fields, and fieldLevels is a vector containing the level index corresponding to each field. byteSize is -1 and fieldLevels is [] if the operation fails.</p> |
| 'attrinfo'       | <pre>[numberType,count,status] = ... hdfpt('attrinfo',point_id,attrname)</pre> | <p>Returns the number type and size in bytes of the specified attribute. attrname is the name of the attribute. numberType is a string corresponding to the HDF data type of the attribute. count is the number of bytes used by the attribute data. status is -1 and numberType and count are [] if the operation fails.</p>                                    |

| Value of funcstr | Function Syntax                                                  | Description                                                                                                                                                                                                                                                                 |
|------------------|------------------------------------------------------------------|-----------------------------------------------------------------------------------------------------------------------------------------------------------------------------------------------------------------------------------------------------------------------------|
| 'inqattrs'       | <code>[nattrs,attrnames] = hdfpt('inqattrs',pointno)</code>      | Retrieve information about attributes defined in a point data set. <code>nattrs</code> and <code>attrnames</code> are the number and names of all the defined attributes, respectively. If the operation fails, <code>nattrs</code> is -1 and <code>attrnames</code> is []. |
| 'inqpoint'       | <code>[numpoints,pointnames] = hdfpt('inqpoint',filename)</code> | Retrieve number and names of point data sets defined in an HDF-EOS file. <code>pointnames</code> is a string containing a comma-separated list of point names. <code>numpoints</code> is -1 and <code>pointnames</code> is [] if the operation fails.                       |

## Utility Routines

Placeholder.

| Value of funcstr | Function Syntax                                                                   | Description                                                                                                                                                                                                                                                                                                          |
|------------------|-----------------------------------------------------------------------------------|----------------------------------------------------------------------------------------------------------------------------------------------------------------------------------------------------------------------------------------------------------------------------------------------------------------------|
| 'getrecnums'     | [outRecords,status] = hdfpt('getrecnums',... point_id,inLevel,outLevel,inRecords) | Returns the record numbers in outLevel corresponding the point_id,inLevel,outLevel,inRecords specified by inRecords in level inLevel. The inLevel and outLevel arguments are zero-based level indices. inRecords is a vector of zero-based record indices. status is -1 and outRecords is [] if the operation fails. |

**Subset Routines**

Subset routines allow reading of data from a specified geographic region.

| Value of funcstr | Function Syntax                                                | Description                                                                                                                                                                                                                   |
|------------------|----------------------------------------------------------------|-------------------------------------------------------------------------------------------------------------------------------------------------------------------------------------------------------------------------------|
| 'defboxregion'   | region_id = hdfpt('defboxregion',point_id,longitude,cornerLon) | Defines a longitude-oriented box region for a point. cornerLon is a two-element vector containing the longitudes of opposite box corners. cornerLat is a two-element vector containing the latitudes of opposite box corners. |

| Value of funcstr | Function Syntax                                                                         | Description                                                                                                                                                                                                         |
|------------------|-----------------------------------------------------------------------------------------|---------------------------------------------------------------------------------------------------------------------------------------------------------------------------------------------------------------------|
|                  |                                                                                         | region_id is -1 if the operation fails.                                                                                                                                                                             |
| 'defvrtregion'   | period_id =<br>hdfpt('defvrtregion', point_id, region_id, field, vert_field, range)     | Defines a vertical region. point_id, region_id, field is the name of the field to subset. range is a two-element vector containing the minimum and maximum vertical values. period_id is -1 if the operation fails. |
| 'regioninfo'     | [byteSize, status] =<br>hdfpt('regioninfo', point_id, region_id, level, fieldlist)      | Returns the data size in bytes of the subset period of the specified level. fieldlist is a string containing a comma-separated list of fields to extract. status and byteSize are -1 if the operation fails.        |
| 'regionrecs'     | [numRec, recNumbers, status] =<br>hdfpt('regionrecs', ... , point_id, region_id, level) | Returns the records numbers within the subsetted region of the specified level. status and numrec are -1 and recNumbers is [] if the operation fails.                                                               |



| Value of funcstr | Function Syntax                                                         | Description                                                                                                                                                                                                                                                                                                                                                                           |
|------------------|-------------------------------------------------------------------------|---------------------------------------------------------------------------------------------------------------------------------------------------------------------------------------------------------------------------------------------------------------------------------------------------------------------------------------------------------------------------------------|
| 'extractregion'  | [data,status] = hdfpt('extractregion',point,region_id,level,fieldList)  | Reads data from the specified subset region. fieldList is a string containing a comma-separated list of requested fields. data is a P-by-1 cell array where P is the number of requested fields. Each cell of data contains an M(k)-by-N matrix of data where M(k) is the order of the k-th field and N is the number of records. status is -1 and data is [] if the operation fails. |
| 'deftimeperiod'  | period_id = hdfpt('deftimeperiod',point,startTime,stopTime)             | Defines a time period point, startTime, stopTime). period_id is -1 if the operation fails.                                                                                                                                                                                                                                                                                            |
| 'periodinfo'     | [byteSize,status] = hdfpt('periodinfo',point,period_id,level,fieldList) | Retrieves the size in bytes, of the subsetted period. fieldList is string containing a comma-separated list of desired field names. byteSize and status are -1 if the operation fails.                                                                                                                                                                                                |

| Value of funcstr | Function Syntax                                                               | Description                                                                                                                                                                                                                                                                                                                                                                                                          |
|------------------|-------------------------------------------------------------------------------|----------------------------------------------------------------------------------------------------------------------------------------------------------------------------------------------------------------------------------------------------------------------------------------------------------------------------------------------------------------------------------------------------------------------|
| 'periodrecs'     | [numRec,recNumbers,status] = hdfpt('periodrecs',... point_id,period_id,level) | Returns the records numbers within the subsetted time period of the specified level. numRec and status are -1 if the operation fails.                                                                                                                                                                                                                                                                                |
| 'extractperiod'  | [data,status] = hdfpt('extractperiod',... point_id,period_id,level,fieldList) | Reads data from the specified subsetted time period of the specified field list. List is a string containing a comma-separated list of requested fields. data is a P-by-1 cell array where P is the number of requested fields. Each cell of data contains an M(k)-by-N matrix of data where M(k) is the order of the k-th field and N is the number of records. status is -1 and data is [] if the operation fails. |

## Input/Output Arguments

Most routines return the flag, `status`, which is 0 when the routine succeeds and -1 when the routine fails. Routines with syntaxes which do not contain `status` return failure information in one of its outputs as notated in the function syntaxes.

`levelName` is a string.

Some of the C library functions accept input values that are defined in terms of C macros. For example, the C `PTopen()` function requires an access mode input that can be `DFACC_READ`, `DFACC_RDWR`, or

DFACC\_CREATE, where these symbols are defined in the appropriate C header file. Where macro definitions are used in the C library, the equivalent MATLAB syntaxes use strings derived from the macro names. You can either use a string containing the entire macro name, or you can omit the common prefix. You can use either upper or lower case. For example, this C function call:

```
status = POpen("PointFile.hdf",DFACC_CREATE)
```

is equivalent to these MATLAB function calls:

```
status = hdfpt('open','PointFile.hdf','DFACC_CREATE')
status = hdfpt('open','PointFile.hdf','dfacc_create')
status = hdfpt('open','PointFile.hdf','CREATE')
status = hdfpt('open','PointFile.hdf','create')
```

In cases where a C function returns a value with a macro definition, the equivalent MATLAB function returns the value as a string containing the lowercase short form of the macro.

HDF number types are specified by strings, including 'uchar8', 'uchar', 'char8', 'char', 'double', 'uint8', 'uint16', 'uint32', 'float', 'int8', 'int16', and 'int32'.

In cases where the HDF-EOS library accepts NULL, use an empty matrix ( []).

**See Also**

matlab.io.hdfEOS.sw

# hdfread

---

**Purpose** Read data from HDF4 or HDF-EOS file

**Syntax**

```
data = hdfread(filename, datasetname)
data = hdfread(hinfo)
data = hdfread(...,param,value,...)
data = hdfread(filename,EOSname,param,value,...)
[data,map] = hdfread(...)
```

**Description** `data = hdfread(filename, datasetname)` returns all the data in the data set specified by `datasetname` from the HDF4 or HDF-EOS file specified by `filename`. To determine the name of a data set in an HDF4 file, use the `hdfinfo` function.

---

**Note** `hdfread` can be used on Version 4.x HDF files or Version 2.x HDF-EOS files. To read data from an HDF5 file, use `h5read`.

---

`data = hdfread(hinfo)` returns all the data in the data set specified by the `structurehinfo`, returned by the `hdfinfo` function. Specify the field in the `hinfo` structure that relates to a particular type of data set, and use indexing to specify which data set, when there are more than one. See “Specify data set to read” on page 1-2986 for more information.

`data = hdfread(...,param,value,...)` returns subsets of the data according to the specified parameter and value pairs. See the tables below to find the valid parameters and values for different types of data sets.

`data = hdfread(filename,EOSname,param,value,...)` subsets the data field from the HDF-EOS point, grid, or swath specified by `EOSname`.

`[data,map] = hdfread(...)` returns the image data and the colormap map for an 8-bit raster image.

## Subsetting Parameters

The following tables show the subsetting parameters that can be used with the `hdfread` function for certain types of HDF4 data. These data types are

- HDF Scientific Data (SD)
- HDF Vdata (V)
- HDF-EOS Grid Data
- HDF-EOS Point Data
- HDF-EOS Swath Data

Note the following:

- If a parameter requires multiple values, use a cell array to store the values. For example, the 'Index' parameter requires three values: `start`, `stride`, and `edge`. Enclose these values in curly braces as a cell array.

```
hdfread(..., 'Index', {start, stride, edge})
```

- All values that are indices are 1-based.

### Subsetting Parameters for HDF Scientific Data (SD) Data Sets

When you are working with HDF SD files, `hdfread` supports the parameters listed in this table.

# hdfread

| Parameter | Description                                                                                                                                                                                                                                                                                                                                                                                                                                                                                                                                                                                                                                                                                                                               |
|-----------|-------------------------------------------------------------------------------------------------------------------------------------------------------------------------------------------------------------------------------------------------------------------------------------------------------------------------------------------------------------------------------------------------------------------------------------------------------------------------------------------------------------------------------------------------------------------------------------------------------------------------------------------------------------------------------------------------------------------------------------------|
| 'Index'   | <p>Three-element cell array, {start, stride, edge}, specifying the location, range, and values to be read from the data set</p> <ul style="list-style-type: none"><li>• <b>start</b> — A 1-based array specifying the position in the file to begin reading<br/>Default: 1, start at the first element of each dimension. The values specified must not exceed the size of any dimension of the data set.</li><li>• <b>stride</b> — A 1-based array specifying the interval between the values to read<br/>Default: 1, read every element of the data set.</li><li>• <b>edge</b> — A 1-based array specifying the length of each dimension to read<br/>Default: An array containing the lengths of the corresponding dimensions</li></ul> |

For example, this code reads the data set `Example SDS` from the HDF file `example.hdf`. The 'Index' parameter specifies that `hdfread` start reading data at the beginning of each dimension, read until the end of each dimension, but only read every other data value in the first dimension.

```
data = hdfread('example.hdf', 'Example SDS', 'Index', {[1],[2 1],[1]})
```

## Subsetting Parameters for HDF Vdata Sets

When you are working with HDF Vdata files, `hdfread` supports these parameters.

| Parameter     | Description                                                                                                      |
|---------------|------------------------------------------------------------------------------------------------------------------|
| 'Fields'      | Text string specifying the name of the field to be read. When specifying multiple field names, use a cell array. |
| 'FirstRecord' | 1-based number specifying the record from which to begin reading                                                 |
| 'NumRecords'  | Number specifying the total number of records to read                                                            |

For example, this code reads the Vdata set `Example Vdata` from the HDF file `example.hdf`.

```
data = hdfread('example.hdf', 'Example Vdata', 'FirstRecord', 2, 'NumRecords', 5)
```

## Subsetting Parameters for HDF-EOS Grid Data

When you are working with HDF-EOS grid data, `hdfread` supports three types of parameters:

- Required parameters
- Optional parameters
- Mutually exclusive parameters — You can only specify one of these parameters in a call to `hdfread`, and you cannot use these parameters in combination with any optional parameter.

| Parameter                                     | Description                                                                                                                                                                                                                                                                                                                                                                                                                                                                                                                                                                                                                                                                     |
|-----------------------------------------------|---------------------------------------------------------------------------------------------------------------------------------------------------------------------------------------------------------------------------------------------------------------------------------------------------------------------------------------------------------------------------------------------------------------------------------------------------------------------------------------------------------------------------------------------------------------------------------------------------------------------------------------------------------------------------------|
| <b>Required Parameter</b>                     |                                                                                                                                                                                                                                                                                                                                                                                                                                                                                                                                                                                                                                                                                 |
| 'Fields'                                      | String specifying the field to be read. You can specify only one field name for a Grid data set.                                                                                                                                                                                                                                                                                                                                                                                                                                                                                                                                                                                |
| <b>Mutually Exclusive Optional Parameters</b> |                                                                                                                                                                                                                                                                                                                                                                                                                                                                                                                                                                                                                                                                                 |
| 'Index'                                       | <p>Three-element cell array, <code>{start, stride, edge}</code>, specifying the location, range, and values to be read from the data set</p> <p><b>start</b> — An array specifying the position in the file to begin reading</p> <p>Default: 1, start at the first element of each dimension. The values must not exceed the size of any dimension of the data set.</p> <p><b>stride</b> — An array specifying the interval between the values to read</p> <p>Default: 1, read every element of the data set.</p> <p><b>edge</b> — An array specifying the length of each dimension to read</p> <p>Default: An array containing the lengths of the corresponding dimensions</p> |

# hdfread

| Parameter                  | Description                                                                                                                                                                                                                                                                                                                                                                                                                                                                                                                                                                                                                                                                   |
|----------------------------|-------------------------------------------------------------------------------------------------------------------------------------------------------------------------------------------------------------------------------------------------------------------------------------------------------------------------------------------------------------------------------------------------------------------------------------------------------------------------------------------------------------------------------------------------------------------------------------------------------------------------------------------------------------------------------|
| 'Interpolate'              | Two-element cell array, {longitude, latitude}, specifying the longitude and latitude points that define a region for bilinear interpolation. Each element is an N-length vector specifying longitude and latitude coordinates.                                                                                                                                                                                                                                                                                                                                                                                                                                                |
| 'Pixels'                   | Two-element cell array, {longitude, latitude}, specifying the longitude and latitude coordinates that define a region. Each element is an N-length vector specifying longitude and latitude coordinates. This region is converted into pixel rows and columns with the origin in the upper left corner of the grid.<br><br>Note: This is the pixel equivalent of reading a 'Box' region.                                                                                                                                                                                                                                                                                      |
| 'Tile'                     | Vector specifying the coordinates of the tile to read, for HDF-EOS Grid files that support tiles                                                                                                                                                                                                                                                                                                                                                                                                                                                                                                                                                                              |
| <b>Optional Parameters</b> |                                                                                                                                                                                                                                                                                                                                                                                                                                                                                                                                                                                                                                                                               |
| 'Box'                      | Two-element cell array, {longitude, latitude}, specifying the longitude and latitude coordinates that define a region. longitude and latitude are each two-element vectors specifying longitude and latitude coordinates.                                                                                                                                                                                                                                                                                                                                                                                                                                                     |
| 'Time'                     | Two-element cell array, [start stop], where start and stop are numbers that specify the start and end-point for a period of time                                                                                                                                                                                                                                                                                                                                                                                                                                                                                                                                              |
| 'Vertical'                 | Two-element cell array, {dimension, range}<br><br>dimension — String specifying the name of the data set field to be read from. You can specify only one field name for a Grid data set.<br><br>range — Two-element array specifying the minimum and maximum range for the subset. If dimension is a dimension name, then range specifies the range of elements to extract. If dimension is a field name, then range specifies the range of values to extract.<br><br>'Vertical' subsetting can be used alone or in conjunction with 'Box' or 'Time'. To subset a region along multiple dimensions, vertical subsetting can be used up to eight times in one call to hdfread. |



For example,

```
data = hdfread('grid.hdf','PolarGrid','Fields','ice_temp','Index', {[5 10],[15 20]})
```

### Subsetting Parameters for HDF-EOS Point Data

When you are working with HDF-EOS Point data, `hdfread` has two required parameters and three optional parameters.

| Parameter                                     | Description                                                                                                                                                                                                              |
|-----------------------------------------------|--------------------------------------------------------------------------------------------------------------------------------------------------------------------------------------------------------------------------|
| <b>Required Parameters</b>                    |                                                                                                                                                                                                                          |
| 'Fields'                                      | String naming the data set field to be read. For multiple field names, use a comma-separated list.                                                                                                                       |
| 'Level'                                       | 1-based number specifying which level to read from in an HDF-EOS Point data set                                                                                                                                          |
| <b>Mutually Exclusive Optional Parameters</b> |                                                                                                                                                                                                                          |
| 'Box'                                         | Two-element cell array, {longitude,latitude}, specifying the longitude and latitude coordinates that define a region. longitude and latitude are each two-element vectors specifying longitude and latitude coordinates. |
| 'RecordNumbers'                               | Vector specifying the record numbers to read                                                                                                                                                                             |
| 'Time'                                        | Two-element cell array, [start stop], where start and stop are numbers that specify the start and endpoint for a period of time                                                                                          |

For example,

```
hdfread(...,'Fields',{field1, field2},...
 'Level',level,'RecordNumbers',[1:50, 200:250])
```

### Subsetting Parameters for HDF-EOS Swath Data

When you are working with HDF-EOS Swath data, `hdfread` supports three types of parameters:

- Required parameters
- Optional parameters

# hdfread

- Mutually exclusive

You can only use one of the mutually exclusive parameters in a call to `hdfread`, and you cannot use these parameters in combination with any optional parameter.

| Parameter                                     | Description                                                                                                                                                                                                                                                                                                                                                                                                                                                                                                                                                                                                                                                                                                                                                         |
|-----------------------------------------------|---------------------------------------------------------------------------------------------------------------------------------------------------------------------------------------------------------------------------------------------------------------------------------------------------------------------------------------------------------------------------------------------------------------------------------------------------------------------------------------------------------------------------------------------------------------------------------------------------------------------------------------------------------------------------------------------------------------------------------------------------------------------|
| <b>Required Parameter</b>                     |                                                                                                                                                                                                                                                                                                                                                                                                                                                                                                                                                                                                                                                                                                                                                                     |
| 'Fields'                                      | String naming the data set field to be read. You can specify only one field name for a Swath data set.                                                                                                                                                                                                                                                                                                                                                                                                                                                                                                                                                                                                                                                              |
| <b>Mutually Exclusive Optional Parameters</b> |                                                                                                                                                                                                                                                                                                                                                                                                                                                                                                                                                                                                                                                                                                                                                                     |
| 'Index'                                       | <p>Three-element cell array, {<code>start</code>, <code>stride</code>, <code>edge</code>}, specifying the location, range, and values to be read from the data set</p> <ul style="list-style-type: none"><li>• <code>start</code> — An array specifying the position in the file to begin reading<br/>Default: 1, start at the first element of each dimension. The values must not exceed the size of any dimension of the data set.</li><li>• <code>stride</code> — An array specifying the interval between the values to read<br/>Default: 1, read every element of the data set.</li><li>• <code>edge</code> — An array specifying the length of each dimension to read<br/>Default: An array containing the lengths of the corresponding dimensions</li></ul> |
| 'Time'                                        | <p>Three-element cell array, {<code>start</code>, <code>stop</code>, <code>mode</code>}, where <code>start</code> and <code>stop</code> specify the beginning and the endpoint for a period of time, and <code>mode</code> is a string defining the criterion for the inclusion of a cross track in a region. The cross track is within a region if any of these conditions is met:</p> <ul style="list-style-type: none"><li>• Its midpoint is within the box (<code>mode='midpoint'</code>).</li><li>• Either endpoint is within the box (<code>mode='endpoint'</code>).</li></ul>                                                                                                                                                                                |

| Parameter                  | Description                                                                                                                                                                                                                                                                                                                                                                                                                                                                                                                                                                                                                                                                                      |
|----------------------------|--------------------------------------------------------------------------------------------------------------------------------------------------------------------------------------------------------------------------------------------------------------------------------------------------------------------------------------------------------------------------------------------------------------------------------------------------------------------------------------------------------------------------------------------------------------------------------------------------------------------------------------------------------------------------------------------------|
| <b>Optional Parameters</b> |                                                                                                                                                                                                                                                                                                                                                                                                                                                                                                                                                                                                                                                                                                  |
| 'Box'                      | <p>Three-element cell array, {longitude, latitude, mode} specifying the longitude and latitude coordinates that define a region. longitude and latitude are two-element vectors that specify longitude and latitude coordinates. mode is a string defining the criterion for the inclusion of a cross track in a region. The cross track is within a region if any of these conditions is met:</p> <ul style="list-style-type: none"> <li>• Its midpoint is within the box (mode='midpoint').</li> <li>• Either endpoint is within the box (mode='endpoint').</li> <li>• Any point is within the box (mode='anypoint').</li> </ul>                                                               |
| 'Vertical'                 | <p>Two-element cell array, {dimension, range}</p> <ul style="list-style-type: none"> <li>• dimension is a string specifying either a dimension name or field name to subset the data by.</li> <li>• range is a two-element vector specifying the minimum and maximum range for the subset. If dimension is a dimension name, then range specifies the range of elements to extract. If dimension is a field name, then range specifies the range of values to extract.</li> </ul> <p>'Vertical' subsetting can be used alone or in conjunction with 'Box' or 'Time'. To subset a region along multiple dimensions, vertical subsetting can be used up to eight times in one call to hdfread.</p> |

For example,

```
hdfread('swath.hdf', 'Example Swath', 'Fields', 'Temperature', ...
 'Time', {5000, 6000, 'midpoint'})
```

# hdfread

---

## Examples

### Read Data Set in HDF File

Specify the name of the HDF file and the name of the data set. This example reads a data set named `temperature` from a sample HDF file.

```
data = hdfread('sd.hdf','temperature');
```

### Specify data set to read

Call `hdfinfo` to retrieve information about the contents of the HDF file.

```
fileinfo = hdfinfo('sd.hdf')
```

```
fileinfo =
```

```
 Filename: 'B:\matlab\toolbox\matlab\imagesci\sd.hdf'
 Attributes: [1x1 struct]
 SDS: [1x2 struct]
 Vdata: [1x1 struct]
```

Extract the structure containing information about the particular data set you want to import from the data returned by `hdfinfo`. This example uses the structure in the `SDS` field to retrieve a scientific data set.

```
sds_info = fileinfo.SDS(2)
```

```
sds_info =
```

```
 Filename: 'B:\matlab\toolbox\matlab\imagesci\sd.hdf'
 Type: 'Scientific Data Set'
 Name: 'temperature'
 Rank: 2
 DataType: 'double'
 Attributes: [1x11 struct]
```

```
 Dims: [2x1 struct]
 Label: {}
 Description: {}
 Index: 1
```

Pass this structure to `hdfread` to import the data in the data set.

```
data = hdfread(sds_info);
```

## Read Data from HDF-EOS Grid Field

Read data from the HDF-EOS global grid field, `TbOceanRain`, in the example file, `example.hdf`.

```
data1 = hdfread('example.hdf', 'MonthlyRain', 'Fields', 'TbOceanRain');
```

Read data for the northern hemisphere for the same field. Use the `Box` parameter to specify the longitude and latitude coordinates for that region.

```
data2 = hdfread('example.hdf', 'MonthlyRain', ...
 'Fields', 'TbOceanRain', ...
 'Box', {[0 360],[0 90]});
```

## Read Subset of Data in Data Set

Retrieve info about the example file, `example.hdf`.

```
fileinfo = hdfinfo('example.hdf');
```

Retrieve information about Scientific Data Set in `example.hdf`.

```
data_set_info = fileinfo.SDS;
```

Check the size of the data set.

```
data_set_info.Dims.Size
```

# hdfread

---

```
ans =

 16
```

```
ans =

 5
```

Read a subset of the data in the data set using the 'index' parameter with `hdfread`. This example specifies a starting index of [3 3], an interval of 1 between values ([] meaning the default value of 1), and a length of 10 rows and 2 columns.

```
data = hdfread(data_set_info,'Index',{[3 3],[],[10 2]});
data(:,1)
```

```
ans =

 7
 8
 9
 10
 11
 12
 13
 14
 15
 16
```

```
data(:,2)
```

```
ans =

 8
 9
 10
 11
 12
 13
 14
 15
 16
 17
```

## Access Data in Fields of Vdata

Use the `Vdata` field from the information returned by `hdfinfo` to read three fields of the data, `Idx`, `Temp`, and `Dewpt`.

```
s = hdfinfo('example.hdf');
data = hdfread(s.Vdata(1), 'Fields', {'Idx', 'Temp', 'Dewpt'})
```

```
data =

 [1x10 int16]
 [1x10 int16]
 [1x10 int16]
```

## See Also

`hdfinfo`

# hdftool

---

**Purpose** Browse and import data from HDF4 or HDF-EOS files

---

**Note** `hdftool` will be removed in a future release. To read data from an HDF file, use `hdfread`, `matlab.io.hdf4.sd`, `matlab.io.hdfeos.gd`, or `matlab.io.hdfeos.sw` instead.

---

**Syntax**

```
hdftool
hdftool(filename)
h = hdftool(...)
```

**Description** `hdftool` starts the HDF Import Tool, a graphical user interface used to browse the contents of HDF4 and HDF-EOS files and import data and subsets of data from these files. To open an HDF4 or HDF-EOS file, select **Open** from the **Home** tab. You can open multiple files in the HDF Import Tool by selecting **Open** from the **Home** tab.

`hdftool(filename)` opens the HDF4 or HDF-EOS file specified by `filename` in the HDF Import Tool.

`h = hdftool(...)` returns a handle `h` to the HDF Import Tool. To close the tool from the command line, use `close(h)`.

**Examples** `hdftool('example.hdf');`

**See Also** `hdfinfo` | `hdfread` | `uiimport`



**Purpose** Gateway to HDF Vgroup (V) interface

**Syntax** `[out1,...,outN] = hdfv(funcstr,input1,...,inputN)`

**Description** hdfv is the MATLAB gateway to the HDF Vgroup (V) interface. `[out1,...,outN] = hdfv(funcstr,input1,...,inputN)` returns one or more outputs corresponding to the V function in the HDF library specified by `funcstr`.

There is a one-to-one correspondence between V functions in the HDF library and valid values for `funcstr`. For example, `hdfv('nattrs',vgroup_id)` corresponds to the C library call `Vnattrs(vgroup_id)`.

**Access Functions**

Access functions open files, initialize the Vgroup interface, and access individual groups. They also terminate access to vgroups and the Vgroup interface and close HDF files.

| <b>Value of funcstr</b> | <b>Function Syntax</b>                                            | <b>Description</b>                                                    |
|-------------------------|-------------------------------------------------------------------|-----------------------------------------------------------------------|
| 'start'                 | <code>status = hdfv('start',file_id)</code>                       | Initializes the V interface.                                          |
| 'attach'                | <code>vgroup_id = hdfv('attach',file_id,vgroup_ref,access)</code> | Establishes access to a group. <code>access</code> can be 'r' or 'w'. |
| 'detach'                | <code>status = hdfv('detach',vgroup_id)</code>                    | Terminates access to a group.                                         |
| 'end'                   | <code>status = hdfv('end',file_id)</code>                         | Terminates access to the V interface.                                 |

**Create Functions**

Create functions organize, label, and add data objects to vgroups.

| Value of funcstr | Function Syntax                                    | Description                                                                       |
|------------------|----------------------------------------------------|-----------------------------------------------------------------------------------|
| 'setclass'       | status =<br>hdfv('setclass', vgroup_id, class)     | Assigns a class to a vgroup.                                                      |
| 'setname'        | status =<br>hdfv('setname', vgroup_id, name)       | Assigns a name to a vgroup.                                                       |
| 'insert'         | ref =<br>hdfv('insert', vgroup_id, id)             | Adds a vgroup or vdata to an existing group. id can be a vdata id or a vgroup id. |
| 'addtagref'      | status =<br>hdfv('addtagref', vgroup_id, tag, ref) | Adds any HDF data objects to an existing vgroup.                                  |
| 'setattr'        | status =<br>hdfv('setattr', vgroup_id, name, A)    | Sets the attribute of a vgroup.                                                   |

## File Inquiry Functions

File inquiry functions return information about how vgroups are stored in a file. They are useful for locating vgroups in a file.

| Value of funcstr | Function Syntax                                   | Description                                                             |
|------------------|---------------------------------------------------|-------------------------------------------------------------------------|
| 'lone'           | [refs, count] =<br>hdfv('lone', file_id, maxsize) | Returns the reference numbers of vgroups not included in other vgroups. |
| 'getid'          | next_ref =<br>hdfv('getid', file_id, vgroup_ref)  | Returns the reference number for the next vgroup in the HDF file.       |

| Value of funcstr | Function Syntax                                  | Description                                                                                   |
|------------------|--------------------------------------------------|-----------------------------------------------------------------------------------------------|
| 'find'           | vgroup_ref =<br>hdfv('find',file_id,vgroup_name) | Returns the reference of the vgroup with the specified name if successful and zero otherwise. |
| 'findclass'      | vgroup_ref =<br>hdfv('findclass',file_id,class)  | Returns the reference in class of the vgroup with the specified class.                        |

### Vgroup Inquiry Functions

Vgroup inquiry functions provide specific information about a specific vgroup. This information includes the class, name, member count, and additional member information.

| Value of funcstr | Function Syntax                                             | Description                                                                                          |
|------------------|-------------------------------------------------------------|------------------------------------------------------------------------------------------------------|
| 'getclass'       | [class_name,status]<br>=<br>hdfv('getclass',vgroup_id)      | Returns the name of the class of the specified group.                                                |
| 'getname'        | [vgroup_name,status]<br>=<br>hdfv('getname',vgroup_id)      | Returns the name of the specified group.                                                             |
| 'inquire'        | [num_entries,name,status]<br>=<br>hdfv('inquire',vgroup_id) | Returns the number of entries and the name of group.                                                 |
| 'isvg'           | status =<br>hdfv('isvg',vgroup_id,ref)                      | Checks if the object specified by ref refers to a child vgroup of the vgroup specified by vgroup_id. |

| Value of funcstr | Function Syntax                                                                       | Description                                                                                               |
|------------------|---------------------------------------------------------------------------------------|-----------------------------------------------------------------------------------------------------------|
| 'isvs'           | status =<br>hdfv('isvs',vgroup_id,vdata_ref)                                          | Checks if the object specified by vdata_ref refers to a child vdata of the vgroup specified by vgroup_id. |
| 'gettagref'      | [tag,ref,status] =<br>hdfv('gettagref',vgroup_id,index)                               | Retrieves a tag/reference number pair for a data object in the specified vgroup.                          |
| 'ntagrefs'       | count =<br>hdfv('ntagrefs',vgroup_id)                                                 | Returns the number of tag/reference number pairs contained in the specified vgroup.                       |
| 'gettagrefs'     | [tag,refs,count] =<br>hdfv('gettagrefs',vgroup_id,maxsize)                            | Retrieves the tag/reference pairs of all the data objects within a vgroup.                                |
| 'inqtagref'      | tf =<br>hdfv('inqtagref',vgroup_id,tag,ref)                                           | Checks if an object belongs to a vgroup.                                                                  |
| 'getversion'     | version =<br>hdfv('getversion',vgroup_id)                                             | Queries the vgroup version of a given vgroup.                                                             |
| 'nattrs'         | count =<br>hdfv('nattrs',vgroup_id)                                                   | Queries the total number of vgroup attributes.                                                            |
| 'attrinfo'       | [name,data_type,count,bytes,status] =<br>hdfv('attrinfo',vgroup_id,...<br>attr_index) | Queries information on a given vgroup attribute.                                                          |

| Value of funcstr | Function Syntax                                                | Description                                                                                            |
|------------------|----------------------------------------------------------------|--------------------------------------------------------------------------------------------------------|
| 'getattr'        | [values,status] =<br>hdfv('getattr',vgroup_id,attribute_index) | Queries the values of a given attribute.                                                               |
| 'Queryref'       | ref =<br>hdfv('Queryref',vgroup_id)                            | Returns the reference number of the specified vgroup.                                                  |
| 'Querytag'       | tag =<br>hdfv('Querytag',vgroup_id)                            | Returns the tag of the specified vgroup.                                                               |
| 'flocate'        | vdata_ref =<br>hdfv('flocate',vgroup_id,field)                 | Returns the reference number of the vdata containing the specified field name in the specified vgroup. |
| 'nrefs'          | count =<br>hdfv('nrefs',vgroup_id,tag)                         | Returns the number of data objects with the specified tag in the specified vgroup.                     |

### Output Arguments

A status or identifier output of -1 indicates that the operation failed.

### See Also

matlab.io.hdf4.sd | hdfdf24 | hdfdf8 | hdfh | hdfhd | hdfhe | hdfhx | hdfml | hdfv | hdfvf | hdfvh | hdfvs

# hdfvf

**Purpose** Gateway to VF functions in HDF Vdata interface

**Syntax** `[out1,...,outN] = hdfvf(funcstr,input1,...,inputN)`

**Description** hdfvf is the MATLAB gateway to the VF unctions in the HDF Vdata interface.

`[out1,...,outN] = hdfvf(funcstr,input1,...,inputN)` returns one or more outputs corresponding to the VF function in the HDF library specified by `funcstr`.

There is a one-to-one correspondence between VF functions in the HDF library and valid values for `funcstr`. For example, `hdfvf('nfields',vdata_id)` corresponds to the C library call `VFnfields(vdata_id)`.

## Field Inquiry Functions

Field inquiry functions provide specific information about the fields in a given vdata, including the field's size, name, order, type, and number of fields in the vdata.

| Value of funcstr | Function Syntax                                               | Description                                                          |
|------------------|---------------------------------------------------------------|----------------------------------------------------------------------|
| 'fieldsize'      | <code>fsize = hdfvf('fieldsize',vdata_id,field_index)</code>  | Retrieves the field size (as stored in a file) of a specified field. |
| 'fieldisize'     | <code>fsize = hdfvf('fieldisize',vdata_id,field_index)</code> | Retrieves the field size (as stored in memory) of a specified field. |
| 'fieldname'      | <code>name = hdfvf('fieldname',vdata_id,field_index)</code>   | Retrieves the name of the specified field in the given vdata.        |
| 'fieldorder'     | <code>order = hdfvf('fieldorder',vdata_id,field_index)</code> | Retrieves the order of the specified field in the given vdata.       |

| Value of funcstr | Function Syntax                            | Description                                                         |
|------------------|--------------------------------------------|---------------------------------------------------------------------|
| 'fieldtype'      | data_type =<br>hdfvf('fieldtype',vdata_id) | Retrieves the data type for the specified field in the given vdata. |
| 'nfields'        | count =<br>hdfvf('nfields',vdata_id)       | Retrieves the total number of fields in the specified vdata.        |

### Output Arguments

A status or identifier output of -1 indicates that the operation failed.

### See Also

matlab.io.hdf4.sd | hdfd24 | hdfd8 | hdfh | hdfhd | hdfhe | hdfhx | hdfml | hdfv | hdfvf | hdfvh | hdfvs

**Purpose** Gateway to VH functions in HDF Vdata interface

**Syntax** `[out1,...,outN] = hdfvh(funcstr,input1,...,inputN)`

**Description** hdfvh is the MATLAB gateway to VH functions in the HDF Vdata interface.

`[out1,...,outN] = hdfvh(funcstr,input1,...,inputN)` returns one or more outputs corresponding to the VH function in the HDF library specified by `funcstr`.

There is a one-to-one correspondence between VH functions in the HDF library and valid values for `funcstr`.

## High-level Vdata Functions

High-level Vdata functions write data to single-field vdatas.

| Value of funcstr | Function Syntax                                                                            | Description                                                       |
|------------------|--------------------------------------------------------------------------------------------|-------------------------------------------------------------------|
| 'makegroup'      | <code>vgroup_ref = hdfvh('makegroup',file_id,data_objects,vgroup_name,vgroup_class)</code> | Groups a collection of data objects within a vgroup.              |
| 'storedata'      | <code>count = hdfvh('storedata',file_id,fieldname,data,...,vdata_name,vdata_class)</code>  | Creates vdatas limited to one field with one component per field. |
| 'storedatam'     | <code>count = hdfvh('storedatam',file_id,fieldname,data,...,vdata_name,vdata_class)</code> | Creates vdatas one field containing one or more components.       |

## Output Arguments

A status or identifier output of -1 indicates that the operation failed.



## See Also

[matlab.io.hdf4.sd](#) | [hdfdf24](#) | [hdfdfr8](#) | [hdfh](#) | [hdfhd](#) | [hdfhe](#) | [hdfhx](#) | [hdfml](#) | [hdfv](#) | [hdfvf](#) | [hdfvh](#) | [hdfvs](#)

# hdfvs

---

**Purpose** Gateway to VS functions in HDF Vdata interface

**Syntax** `[out1,...,outN] = hdfvs(funcstr,input1,...,inputN)`

**Description** hdfvs is the MATLAB gateway to the VS functions in the HDF Vdata interface.

`[out1,...,outN] = hdfvs(funcstr,input1,...,inputN)` returns one or more outputs corresponding to the VS function in the HDF library specified by `funcstr`.

There is a one-to-one correspondence between VS functions in the HDF library and valid values for `funcstr`. For example, `hdfvs('detach',vdata_id)` corresponds to the C library call `VSdetach(vdata_id)`.

## Access Functions

Access functions attach, or allow access, to vdatas. Data transfer can only occur after a vdata has been accessed. These routines also detach from, or properly terminate access to, vdatas when data transfer has been completed.

| Value of <code>funcstr</code> | Function Syntax                                                    | Description                                                        |
|-------------------------------|--------------------------------------------------------------------|--------------------------------------------------------------------|
| 'attach'                      | <code>vdata_id = hdfvs('attach',file_id,specified_vdata_id)</code> | Establishes access to a specified vdata. Access can be 'r' or 'w'. |
| 'detach'                      | <code>status = hdfvs('detach',vdata_id)</code>                     | Terminates access to a specified vdata.                            |

## Read and Write Functions

Read and write functions read and write the contents of a vdata.

| Value of funcstr | Function Syntax                                                     | Description                                                                                                                                                                                                                    |
|------------------|---------------------------------------------------------------------|--------------------------------------------------------------------------------------------------------------------------------------------------------------------------------------------------------------------------------|
| 'fdefine'        | status =<br>hdfvs('fdefine', vdata_id, data_name, data_type, order) | Defines a new vdata field. data_name is a string specifying the HDF number type. It can be any these strings: 'uchar8', 'uchar', 'char8', 'char', 'double', 'uint8', 'uint16', 'uint32', 'float', 'int8', 'int16', or 'int32'. |
| 'setclass'       | status =<br>hdfvs('setclass', vdata_id, class)                      | Assigns a class to a vdata.                                                                                                                                                                                                    |
| 'setfields'      | status =<br>hdfvs('setfields', vdata_id, fields)                    | Specifies the vdata fields written.                                                                                                                                                                                            |
| 'setinterlace'   | status =<br>hdfvs('setinterlace', vdata_id, interlace)              | Sets the interlace mode for a vdata. interlace can be 'full' or 'no'.                                                                                                                                                          |
| 'setname'        | status =<br>hdfvs('setname', vdata_id, name)                        | Assigns a name to a vdata.                                                                                                                                                                                                     |

# hdfvs

| Value of funcstr | Function Syntax                                       | Description                                                                                                                                                                                                                                                                                             |
|------------------|-------------------------------------------------------|---------------------------------------------------------------------------------------------------------------------------------------------------------------------------------------------------------------------------------------------------------------------------------------------------------|
| 'write'          | count =<br>hdfvs('write',<br>vdata_id, data)          | Writes to a vdata. data must be an nfields-by-1 cell array. Each cell must contain an order(i)-by-n vector of data where order(i) is the number of scalar values in each field. The types of the data must match the field types set via hdfvs('setfields') or the fields in an already existing vdata. |
| 'read'           | [data,count] =<br>hdfvs('read',vdata_id               | Reads from a vdata. Data is returned in a nfields-by-1 cell array. Each cell contains a order(i)-by-n vector of data where order is the number of scalar values in each field. The fields are returned in the same order as specified in hdfvs('setfields',...).                                        |
| 'seek'           | pos =<br>hdfvs('seek',vdata_id                        | Seeks to a specified record in a vdata.                                                                                                                                                                                                                                                                 |
| 'setattr'        | status =<br>hdfvs('setattr',vdata_id,field_index,data | Sets the attribute of a field in a vdata.                                                                                                                                                                                                                                                               |

| Value of funcstr  | Function Syntax                                                          | Description                                                                                                                                                                                                                                                   |
|-------------------|--------------------------------------------------------------------------|---------------------------------------------------------------------------------------------------------------------------------------------------------------------------------------------------------------------------------------------------------------|
| 'setexternalfile' | status =<br>hdfvs('setexternalfile', information, filename, offset)      | Stores vdata information in an external file.                                                                                                                                                                                                                 |
| 'getattr'         | [value, status] =<br>hdfvs('getattr', vdata_id, field_index, attr_index) | Reads the value of an attribute attached to vdata or a vdata field. Set field_index to 'vdata' to retrieve an attribute attached to the field itself. Set field_index to the numerical index of the field to retrieve an attribute attached to a vdata field. |
| 'setattr'         | status =<br>hdfvs('setattr', vdata_id, field_index, name, A)             | Sets the attribute of a vdata field. vdata.field_index can be an index number or 'vdata'.                                                                                                                                                                     |

### File Inquiry Functions

File inquiry functions provide information about how vdatas are stored in a file. They are useful for locating vdatas in a file.

| Value of funcstr | Function Syntax                                       | Description                                                                                 |
|------------------|-------------------------------------------------------|---------------------------------------------------------------------------------------------|
| 'find'           | vdata_ref =<br>hdfvs('find',file_id,vdata_name)       | Searches for a given vdata name in the specified HDF file.                                  |
| 'findclass'      | vdata_ref =<br>hdfvs('findclass',file_id,vdata_class) | Returns the reference number of the first vdata corresponding to the specified vdata class. |
| 'getid'          | next_ref =<br>hdfvs('getid',file_id,vdata_ref)        | Returns the identifier of the next vdata in the file.                                       |
| 'lone'           | [refs,count] =<br>hdfvs('lone',file_id,max_refs)      | Returns the reference numbers of the vdatas that are not linked into vgroups.               |

## Vdata Inquiry Functions

Vdata inquiry functions provide specific information about a given vdata, including the vdata's name, class, number of fields, number of records, tag and reference pairs, interlace mode, and size.

| Value of funcstr | Function Syntax                                                                    | Description                                               |
|------------------|------------------------------------------------------------------------------------|-----------------------------------------------------------|
| 'fexist'         | status =<br>hdfvs('fexist',vdata_id,fields)                                        | Tests for the existence of fields in the specified vdata. |
| 'inquire'        | [n,interlace,fields,bytes,vdata_name,status]<br>= ...<br>hdfvs('inquire',vdata_id) | Returns information about the specified vdata.            |

| Value of funcstr | Function Syntax                                        | Description                                            |
|------------------|--------------------------------------------------------|--------------------------------------------------------|
| 'elts'           | count =<br>hdfvs('elts',vdata_id)                      | Returns the number of records in the specified vdata.  |
| 'getclass'       | [class_name,status] =<br>hdfvs('getclass',vdata_id)    | Returns the HDF class of the specified vdata.          |
| 'getfields'      | [field_names,count] =<br>hdfvs('getfields',vdata_id)   | Returns all field names within the specified vdata.    |
| 'getinterlace'   | [interlace,status] =<br>hdfvs('getinterlace',vdata_id) | Retrieves the interlace mode of the specified vdata.   |
| 'getname'        | [vdata_name,status] =<br>hdfvs('getname',vdata_id)     | Retrieves the name of the specified vdata.             |
| 'getversion'     | version =<br>hdfvs('getversion',vdata_id)              | Returns the version number of a vdata.                 |
| 'sizeof'         | nbytes =<br>hdfvs('sizeof',vdata_id)                   | Returns the fields sizes of the specified vdata.       |
| 'Queryfields'    | [fields,status] =<br>hdfvs('Queryfields',vdata_id)     | Returns the field names of the specified vdata.        |
| 'Queryname'      | [name,status] =<br>hdfvs('Queryname',vdata_id)         | Returns the name of the specified vdata.               |
| 'Queryref'       | ref =<br>hdfvs('Queryref',vdata_id)                    | Retrieves the reference number of the specified vdata. |
| 'Querytag'       | tag =<br>hdfvs('Querytag',vdata_id)                    | Retrieves the tag of the specified vdata.              |

# hdfvs

| Value of funcstr | Function Syntax                                            | Description                                                                                   |
|------------------|------------------------------------------------------------|-----------------------------------------------------------------------------------------------|
| 'Querycount'     | [count,status] = hdfvs('Querycount',vdata)                 | Returns the number of records in the specified vdata.                                         |
| 'Queryinterlace' | [interlace,status] = hdfvs('Queryinterlace',vdata)         | Returns the interlace mode of the specified vdata.                                            |
| 'Queryvsize'     | vsize = hdfvs('Queryvsize',vdata)                          | Retrieves the local size in bytes of the specified vdata record.                              |
| 'findex'         | [field_index,status] = hdfvs('findex',vdata,field_name)    | Queries the index of a vdata field given the field name.                                      |
| 'nattrs'         | count = hdfvs('nattrs',vdata)                              | Returns the number of attributes of the specified vdata and the vdata fields contained in it. |
| 'fnattrs'        | count = hdfvs('fnattrs',vdata)                             | Queries the total number of vdata attributes.                                                 |
| 'findattr'       | attr_index = hdfvs('findattr',vdata,field_index,attr_name) | Retrieves the index of an attribute given the attribute name.                                 |



| Value of funcstr | Function Syntax                                                                                        | Description                                                                                                                    |
|------------------|--------------------------------------------------------------------------------------------------------|--------------------------------------------------------------------------------------------------------------------------------|
| 'isattr'         | tf =<br>hdfvs('isattr',vdata_id)                                                                       | Determines if the given data is an attribute.                                                                                  |
| 'attrinfo'       | [name,data_type,count,bytes,status] =<br>hdfvs('attrinfo',...<br>vdata_id,field_index,attribute_index) | Returns the name, data type, number of values, and the size of the specified attributes of the specified vdata field or vdata. |

### Output Arguments

A status or identifier output of -1 indicates that the operation failed.

### See Also

matlab.io.hdf4.sd | hdfdf24 | hdfdf8 | hdfh | hdfhd | hdfhe | hdfhx | hdfml | hdfv | hdfvf | hdfvh | hdfvs

# height

---

**Purpose** Number of table rows

**Syntax** H = height(T)

**Description** H = height(T) returns the number of rows in the table, T.  
height(T) is equivalent to size(T,1).

**Input Arguments** **T - Input table**  
table  
Input table, specified as a table.

## Examples **Number of Table Rows**

Create a table, T.

```
LastName = {'Smith';'Johnson';'Williams';'Jones';'Brown'};
Age = [38;43;38;40;49];
Height = [71;69;64;67;64];
Weight = [176;163;131;133;119];
BloodPressure = [124 93; 109 77; 125 83; 117 75; 122 80];
```

```
T = table(Age,Height,Weight,BloodPressure,'RowNames',LastName)
```

```
T =
```

|          | Age | Height | Weight | BloodPressure |    |
|----------|-----|--------|--------|---------------|----|
|          | —   | —      | —      | —             |    |
| Smith    | 38  | 71     | 176    | 124           | 93 |
| Johnson  | 43  | 69     | 163    | 109           | 77 |
| Williams | 38  | 64     | 131    | 125           | 83 |
| Jones    | 40  | 67     | 133    | 117           | 75 |
| Brown    | 49  | 64     | 119    | 122           | 80 |

Find the number of rows in table T.

```
H = height(T)
```

```
H =
```

```
5
```

T contains five rows; `height` does not count the variable names.

## See Also

`width` | `size` | `numel`

# help

---

**Purpose** Help for functions in Command Window

**Syntax** `help`  
`help name`

**Description** `help` lists all primary help topics in the Command Window. Each main help topic corresponds to a folder name on the MATLAB search path.

`help name` displays the help text for the functionality specified by `name`, such as a function, method, class, or toolbox.

- Tips**
- Some help text displays the names of functions in uppercase characters to make them stand out from the rest of the text. When typing these function names, use lowercase. For function names that appear in mixed case (such as `javaObject`), type the names as shown.
  - To prevent long descriptions from scrolling off the screen before you have time to read them, enter `more on`, and then enter the `help` statement.
  - Some classes require that you specify the package name to display the help text. To identify the package name, create an instance of the class, and then call `class(obj)`.

**Input Arguments**

**name**  
String that specifies an operator symbol (such as `+`) or the name of a function, class, method, package, toolbox folder, or other functionality.

Some classes and other packaged items require that you specify the package name. Events, properties, and some methods require that you specify the class name. Separate the components of the name with periods, such as:

```
help className.name
help packageName.name
help packageName.className.name
```

If `name` is overloaded, that is, appears in multiple folders on the search path, `help` displays the help text for the first instance of `name` found on the search path, and displays a hyperlinked list of the overloaded functions and their folders.

When `name` specifies the name or partial path of a toolbox folder:

- If the folder contains a nonempty `Contents.m` file, the `help` function displays the file. `Contents.m` contains a list of MATLAB program files in the folder and their descriptions. If `Contents.m` exists, but is empty, MATLAB responds with `No help found for name.`
- If the folder does not contain a `Contents.m` file, the `help` function lists the first line of help text for each program file in the folder.
- If `name` is the name of both a function and a toolbox, `help` displays the associated text for both the toolbox and the function.

## Examples

### Functions and Overloaded Methods

Display help for the MATLAB `close` function.

```
help close
```

Because `close` refers to the name of a function and to the name of several methods, the help text includes hyperlinks to the overloaded methods.

Request help for the Database Toolbox™ `close` method.

```
help database.close
```

### Package, Class, and Method Help

Display help for the `containers` package, `Map` class, and the `isKey` method.

```
help containers
help containers.Map
help containers.Map.isKey
```

Not all packages, classes, and associated methods or events require complete specification. For example, display the help for the `throwAsCaller` method of the `MException` class.

```
help throwAsCaller
```

## Functions in Folder

List all of the functions in the folder `matlabroot/toolbox/matlab/general` by specifying a partial path.

```
help general
```

## Alternatives

View more extensive help using the `doc` command or the Function Browser. To open the Function Browser, click its icon, .

## See Also

`class` | `dbtype` | `doc` | `lookfor` | `more` | `path` | `what` | `which` | `whos`

## How To

- “Ways to Get Function Help”
- “Add Help for Your Program”

**Purpose** Open Help browser to access online documentation

---

**Note** helpbrowser will be removed in a future release. Use doc instead.

---

**Syntax** helpbrowser

**Description** helpbrowser displays the Help browser, open to its default startup page.

**See Also** doc | help

**How To**

- “Ways to Get Function Help”

# helpdesk

---

**Purpose** Open Help browser

---

**Note** helpdesk will be removed in a future release. Use doc instead.

---

**Syntax** helpdesk

**Description** helpdesk opens the Help browser to the default startup page. In previous releases, helpdesk displayed the Help Desk, which was the precursor to the Help browser.

**See Also** doc



**Purpose** Create and open help dialog box

**Syntax**

```
helpdlg
helpdlg('helpstring')
helpdlg('helpstring','dlgname')
h = helpdlg(...)
```

**Description** helpdlg creates a nonmodal help dialog box or brings the named help dialog box to the front.

---

**Note** A nonmodal dialog box enables the user to interact with other windows before responding. For more information, see `WindowState` in the MATLAB Figure Properties.

---

helpdlg displays a dialog box named 'Help Dialog' containing the string 'This is the default help string.'

helpdlg('helpstring') displays a dialog box named 'Help Dialog' containing the string specified by 'helpstring'.

helpdlg('helpstring','dlgname') displays a dialog box named 'dlgname' containing the string 'helpstring'.

h = helpdlg(...) returns the handle of the dialog box.

**Tips** MATLAB wraps the text in 'helpstring' to fit the width of the dialog box. The dialog box remains on your screen until you press the **OK** button or the **Enter** key. After either of these actions, the help dialog box disappears.

**Examples** The statement

```
helpdlg('Choose 10 points from the figure',...
 'Point Selection');
```

displays this dialog box:

# helpdlg

---

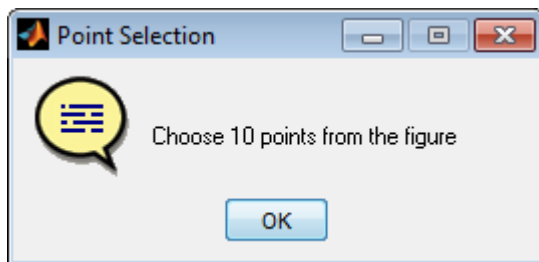

## See Also

[dialog](#) | [errordlg](#) | [inputdlg](#) | [listdlg](#) | [msgbox](#) | [questdlg](#) | [warndlg](#) | [figure](#) | [uiwait](#) | [uiresume](#)

**Purpose** Provide access to help comments for all functions

---

**Note** helpwin will be removed in a future release. Use doc instead.

---

**Syntax** helpwin  
helpwin topic

**Description** helpwin lists topics for groups of functions in the MATLAB Help browser. It shows brief descriptions of the topics and provides links to display help comments for the functions. You cannot follow links in the helpwin list of functions if the MATLAB software is busy (for example, running a program).

helpwin topic displays help information for the topic. If topic is a folder, it displays all functions in the folder. If topic is a function, helpwin displays help for that function. From the page, you can access a list of folders (**Default Topics** link) as well as the reference page help for the function (**Go to online doc** link). You cannot follow links in the helpwin list of functions if MATLAB is busy (for example, running a program).

**Examples** Typing  
helpwin datafun  
displays the functions in the datafun folder and a brief description of each.

Typing  
helpwin fft  
displays the help for the fft function.

**See Also** doc | help

# hess

---

**Purpose** Hessenberg form of matrix

**Syntax**  
 $H = \text{hess}(A)$   
 $[P, H] = \text{hess}(A)$   
 $[AA, BB, Q, Z] = \text{hess}(A, B)$

**Description**  $H = \text{hess}(A)$  finds  $H$ , the Hessenberg form of matrix  $A$ .  
 $[P, H] = \text{hess}(A)$  produces a Hessenberg matrix  $H$  and a unitary matrix  $P$  so that  $A = P*H*P'$  and  $P'*P = \text{eye}(\text{size}(A))$ .  
 $[AA, BB, Q, Z] = \text{hess}(A, B)$  for square matrices  $A$  and  $B$ , produces an upper Hessenberg matrix  $AA$ , an upper triangular matrix  $BB$ , and unitary matrices  $Q$  and  $Z$  such that  $Q*A*Z = AA$  and  $Q*B*Z = BB$ .

**Definitions** A Hessenberg matrix is zero below the first subdiagonal. If the matrix is symmetric or Hermitian, the form is tridiagonal. This matrix has the same eigenvalues as the original, but less computation is needed to reveal them.

**Examples**  $H$  is a 3-by-3 eigenvalue test matrix:

```
H =
 -149 -50 -154
 537 180 546
 -27 -9 -25
```

Its Hessenberg form introduces a single zero in the (3,1) position:

```
hess(H) =
 -149.0000 42.2037 -156.3165
 -537.6783 152.5511 -554.9272
 0 0.0728 2.4489
```

**See Also** [eig](#) | [qz](#) | [schur](#)

## Purpose

Superclass for heterogeneous array formation

## Description

`matlab.mixin.Heterogeneous` is an abstract class that provides support for the formation of heterogeneous arrays. A heterogeneous array is an array of objects that differ in their specific class, but are all derived from or are instances of a root class. The root class derives directly from `matlab.mixin.Heterogeneous`.

## Heterogeneous Hierarchy

Use `matlab.mixin.Heterogeneous` to define hierarchies of classes whose instances you can combine into heterogeneous arrays.

The following class definition enables the formation of heterogeneous arrays that combine instances of any classes derived from `HierarchyRoot`.

```
classdef HierarchyRoot < matlab.mixin.Heterogeneous
% HierarchyRoot is a direct subclass of
% matlab.mixin.Heterogeneous
% HierarchyRoot is the root of this heterogeneous hierarchy
```

Deriving the `HierarchyRoot` class directly from `matlab.mixin.Heterogeneous` enables the `HierarchyRoot` class to become the root of a hierarchy of classes. You can combine instances of the members of this hierarchy into a heterogeneous array. Only instances of classes derived from the same root class can combine to form a valid heterogeneous array.

## Class of a Heterogeneous Array

The class of a heterogeneous array is always the class of the most specific superclass common to all objects in the array. For example, suppose you define the following class hierarchy:

# matlab.mixin.Heterogeneous

---

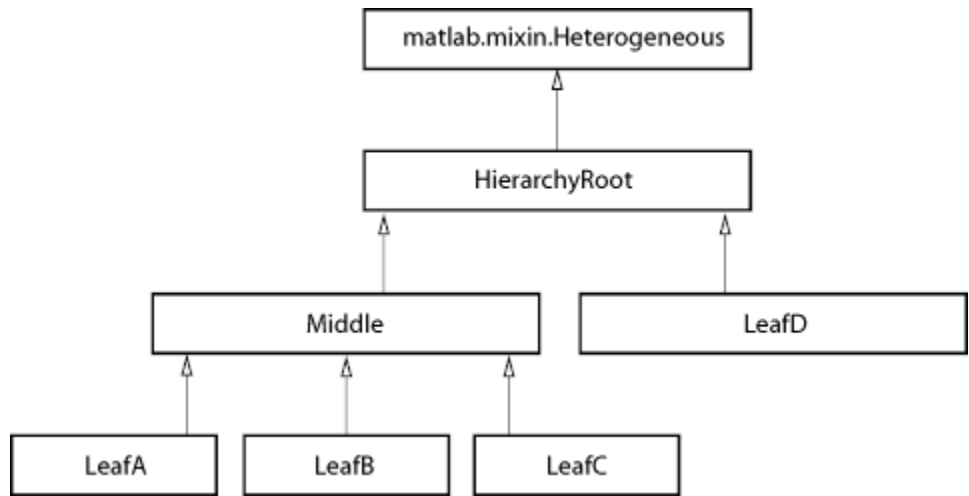

Forming an array (harray) of an instance of LeafA with an instance of LeafB creates an array of class Middle:

```
harray = [LeafA,LeafB];
class(harray)
ans =
Middle
```

Forming an array (harray) of an instance of LeafC with an instance of LeafD creates an array of class HierarchyRoot:

```
harray = [LeafC,LeafD];
class(harray)
ans =
HierarchyRoot
```

Forming an array (harray) of an instance of LeafA with an other instance of LeafA creates a homogeneous array of class LeafA:

```
harray = [LeafA,LeafA];
class(harray)
ans =
```

LeafA

---

**Note** You cannot form heterogeneous arrays that include instances of classes that are not derived from the same hierarchy root (that is, the `HierarchyRoot` class in the hierarchy shown previously).

---

### Forming a Heterogeneous Array

Heterogeneous arrays are the result of operations that produces arrays containing instances of two or more classes from the heterogeneous hierarchy. Usually, concatenation or indexed assignment form these arrays. For example, these statements form `harray` using indexed assignment:

```
harray(1) = LeafA;
harray(2) = LeafC;
class(harray)
ans =
Middle
```

### Growing the Array Can Change Its Class

Assigning new objects into an array containing objects derived from `matlab.mixin.Heterogeneous` can change the class of the array. For example, given a homogeneous array containing objects only of the `LeafA` class:

```
harray = [LeafA,LeafA,LeafA];
class(harray)
ans =
LeafA
```

Adding an object of another class derived from the same root to `harray` converts the array's class to the most specific superclass:

```
harray(4) = LeafB;
class(harray)
ans =
```

Middle

## Method Dispatching

When MATLAB invokes a method for which the dominant argument is a heterogeneous array, the method:

- Must be defined for the class of the heterogeneous array, either directly by the class of the array or inherited from a superclass.
- Must be `Sealed = true` (cannot be overridden by a subclass).

The class of the heterogeneous array determines which class method executes for any given method invocation, as is the case with a homogeneous array. MATLAB does not consider the class of individual elements in the array when dispatching to methods.

## Sealing Inherited Methods

The requirement that methods called on a heterogeneous array be `Sealed = true` ensures correct and predictable behavior with all array elements.

You must override methods that are inherited from outside the heterogeneous hierarchy if these methods are not `Sealed = true` and you want to call these methods on heterogeneous arrays.

For example, suppose you define a heterogeneous array by subclassing `hgsetget`, in addition to `matlab.mixin.Heterogeneous`. Override the `set` method to call the `hgsetget` superclass method as required by your class design:

```
methods(Sealed)
function varargout = set(obj,varargin)
 if nargin == 0
 set@hgsetget(obj, varargin{:});
 else
 varargout{:} = set@hgsetget(obj,varargin{:});
 end
end
end
```



Method implementations can take advantage of the fact that, given a heterogeneous array `harray`, and a scalar index `n`, the expression

```
harray(n)
```

is not a heterogeneous array. Therefore, when invoking a method on a single element of a heterogeneous array, special requirements for heterogeneous arrays do not apply.

## Defining the Default Object

When working with object arrays (both heterogeneous and homogeneous), MATLAB creates default objects to fill in missing array elements by calling the class constructor with no arguments. Filling in missing array elements becomes necessary in cases such as:

- Indexed assignment creates an array with gaps. For example, if `harray` is not previously defined:

```
harray(5) = LeafA;
```

- Loading a heterogeneous array from a MAT-file when MATLAB cannot find the class definition of a specific object.

The `matlab.mixin.Heterogeneous` class provides a default implementation of a method called `getDefaultScalarElement`. This method returns an instance of the root class of the heterogeneous hierarchy, unless the root class is abstract.

If the root class is abstract or is not an appropriate default object for the classes in the heterogeneous hierarchy, you can override the `getDefaultScalarElement` method to return an instance of a class derived from the root class.

## Defining the `getDefaultScalarElement` Method

Specify the class of the default object by overriding the `matlab.mixin.Heterogeneous` method called `getDefaultScalarElement` in the root class of the heterogeneous

# matlab.mixin.Heterogeneous

---

hierarchy. You can override `getDefaultScalarElement` only in the root class (direct subclasses of `matlab.mixin.Heterogeneous`).

`getDefaultScalarElement` has the following signature:

```
methods (Static, Sealed, Access = protected)
 function default_object = getDefaultScalarElement
 ...
 end
end
```

The `getDefaultScalarElement` method must satisfy these criteria:

- Static — MATLAB calls this method without an object.
- Protected — MATLAB calls this method, object users do not.
- Sealed (not required) — Seal this method to ensure users of the heterogeneous hierarchy do not change the intended behavior of the class.
- It must return a scalar object
- It must pass the `isa` test for the root class, that is:

```
(isa(getDefaultScalarElement, 'HierarchyRoot'))
```

where *HierarchyRoot* is the name of the heterogeneous hierarchy root class. This means the default object can be an instance of any class derived from the root class.

## Cannot Redefine Indexing or Concatenation

The use of heterogeneous arrays requires consistent indexing and concatenation behaviors. Therefore, subclasses of `matlab.mixin.Heterogeneous` cannot change their default indexed reference, indexed assignment, or concatenation behavior.

You cannot override the following methods in your subclasses:

- `cat`

- horzcat
- vertcat
- subref
- subsasign

In cases involving multiple inheritance in which your subclass inherits from superclasses in addition to `matlab.mixin.Heterogeneous`, the superclasses cannot define any of these methods.

### **Default Concatenation Behavior**

Statements of the form:

```
a = [obj1,obj2,...];
```

create an array, `a`, containing the objects listed in brackets.

Concatenating `Heterogeneous` objects of the same specific class retains the class of the objects and does not form a heterogeneous array.

Concatenating `Heterogeneous` objects derived from the same root superclass, but that are of different specific classes, yields a heterogeneous array. MATLAB does not attempt to convert the class of any array members if all are part of the same root hierarchy.

### **Indexed Assignment Behavior**

Statements of the form:

```
a(m:n) = [objm,...objn];
```

assign the right-hand side objects to the array elements (`m:n`), specified on the left side of the assignment.

Indexed assignment to a heterogeneous array can:

- Increase or decrease the size of the array
- Overwrite existing array elements
- Change property values of objects within the array

- Change the class of the array
- Change whether the array is heterogeneous

## Indexed Reference Behavior

Statements of the form:

```
a = harray(m:n);
```

assign the elements of `harray` referenced by indices `m:n`, to array `a`.

Indexed reference on a heterogeneous array returns a sub-range of the original array. Depending on the specific elements within that sub-range (`m:n`), the result might have a different class than the original array, and might not be heterogeneous.

## Converting Nonmember Objects

If you attempt to form a heterogeneous array with objects that are not derived from the same root class, MATLAB calls the `convertObject` method, if it exists, to convert objects to the dominant class. Implementing a `convertObject` method enables the formation of heterogeneous arrays containing objects that are not part of the heterogeneous hierarchy.

## When Is Conversion Necessary

Suppose there are two classes `A` and `B`, where `B` is not derived from `matlab.mixin.Heterogeneous`, or where `A` and `B` are derived from different root classes that are derived from `matlab.mixin.Heterogeneous`.

MATLAB attempts to call the `convertObject` method implemented by the root class of `A` in the following cases:

- The indexed assignment:  
$$A(k) = B$$
- Horizontal and vertical concatenations:

$[A,B]$  and  $[A;B]$

Implement a `convertObject` method if you want to support conversion of objects whose class is not defined in your heterogeneous hierarchy. You do not need to implement this method if your class design does not require this conversion.

## Implementing `convertObject`

Only the root class of the heterogeneous hierarchy can implement a `convertObject` method.

The `convertObject` method must have the following signature:

```
Method (Static, Sealed, Access = protected)
 function cobj = convertObject('DomClass',objToConvert)
 ...
 end
end
```

For indexed assignment  $A(k) = B$  and concatenation  $[A,B]$ :

- *DomClass* — Name of the class of the array A
- *objToConvert* — Object to be converted, B in this case
- *cobj* — Legal member of the heterogeneous hierarchy to which A belongs

You must implement `convertObject` to return a valid object of class A or MATLAB issues an error.

## Handle Compatibility

The `matlab.mixin.Heterogeneous` class is handle compatible. It can be combined with either handle or value classes when defining a subclass using multiple superclasses. See “Supporting Both Handle and Value Subclasses” for information on handle compatibility.

The `matlab.mixin.Heterogeneous` class is a value class. To learn how value classes affect copy operations, see Copying Objects in the MATLAB Programming Fundamentals documentation

# matlab.mixin.Heterogeneous

---

## Methods

|                                      |                                                          |
|--------------------------------------|----------------------------------------------------------|
| <code>cat</code>                     | Concatenation for heterogeneous arrays                   |
| <code>getDefaultScalarElement</code> | Return default object for heterogeneous array operations |
| <code>horzcat</code>                 | Horizontal concatenation for heterogeneous arrays        |
| <code>vertcat</code>                 | Vertical concatenation for heterogeneous arrays          |

## See Also

`handle`

## How To

- Class Attributes
- Property Attributes
- “Creating Subclasses — Syntax and Techniques”

**Purpose** Concatenation for heterogeneous arrays

**Syntax** `C = cat(dim,A,B)`

**Description** `C = cat(dim,A,B)` concatenates objects A and B along the dimension dim. The class of object arrays A and B must be derived from the same root class of a `matlab.mixin.Heterogeneous` hierarchy.

- If A and B are of the same class, the class of the resulting array is unchanged.
- If A and B are of different subclasses of a common superclass that is derived from `matlab.mixin.Heterogeneous`, then the result is a heterogeneous array and the array's class is that of the most specific superclass shared by A and B.

The `cat` method is sealed in the class `matlab.mixin.Heterogeneous` and, therefore, you cannot override it in subclasses.

## Input Arguments

**dim**

Scalar dimension along which to concatenate arrays

**A**

Object array derived from the same root subclass of `matlab.mixin.Heterogeneous` as B

**B**

Object array derived from the same root subclass of `matlab.mixin.Heterogeneous` as A

## Output Arguments

**C**

Array resulting from the specified concatenation. The class of this array is that of the most specific superclass shared by A and B.

# matlab.mixin.Heterogeneous.cat

---

## Attributes

Sealed true

To learn about attributes of methods, see Method Attributes in the MATLAB Object-Oriented Programming documentation.

## See Also

`matlab.mixin.Heterogeneous` | `cat`



# matlab.mixin.Heterogeneous.getDefaultScalarElement

## Purpose

Return default object for heterogeneous array operations

## Syntax

```
defaultObject = getDefaultScalarElement
```

## Description

`defaultObject = getDefaultScalarElement` returns the default object for a heterogeneous hierarchy. Override this method if the “Root Class” on page 1-3032 is abstract or is not an appropriate default object for the classes in the heterogeneous hierarchy. `getDefaultScalarElement` must return an instance of another member of the heterogeneous hierarchy.

The `matlab.mixin.Heterogeneous` class provided a default implementation of this method that returns an instance of the “Root Class” on page 1-3032.

MATLAB calls the `getDefaultScalarElement` method when requiring a default object. See `matlab.mixin.Heterogeneous` for more information on heterogeneous arrays and default objects.

## Tips

- Override `getDefaultScalarElement` only if the “Root Class” on page 1-3032 is not suitable as a default object.
- Override `getDefaultScalarElement` only in the “Root Class” on page 1-3032 of the heterogeneous hierarchy.
- `getDefaultScalarElement` must return a scalar object.
- `getDefaultScalarElement` must be a static method with protected access. While not required by MATLAB, you can seal this method to prevent overriding by other classes.
- MATLAB returns an error if the value returned by `getDefaultScalarElement` is not scalar or is not an instance of a class that is a valid member of the hierarchy.

## Output Arguments

### **defaultObject**

The default object for heterogeneous array operations.

# matlab.mixin.Heterogeneous.getDefaultScalarElement

---

## Definitions

### Root Class

Root class – The direct subclass of `matlab.mixin.Heterogeneous` that forms the root of a heterogeneous hierarchy. Classes of objects that you can combine into heterogeneous arrays must derive from this root class.

## Attributes

|        |                   |
|--------|-------------------|
| Static | true              |
| Access | Protected         |
| Sealed | true not required |

To learn about attributes of methods, see [Method Attributes](#) in the [MATLAB Object-Oriented Programming](#) documentation.

## Examples

This example describes a heterogeneous hierarchy with a root class (`FinancialObjects`) that is an abstract class and cannot, therefore, be used for the default object. The `FinancialObjects` class definition includes an override of the `getDefaultScalarElement` method which returns an instance of the `Assets` class as the default object.

# matlab.mixin.Heterogeneous.getDefaultScalarElement

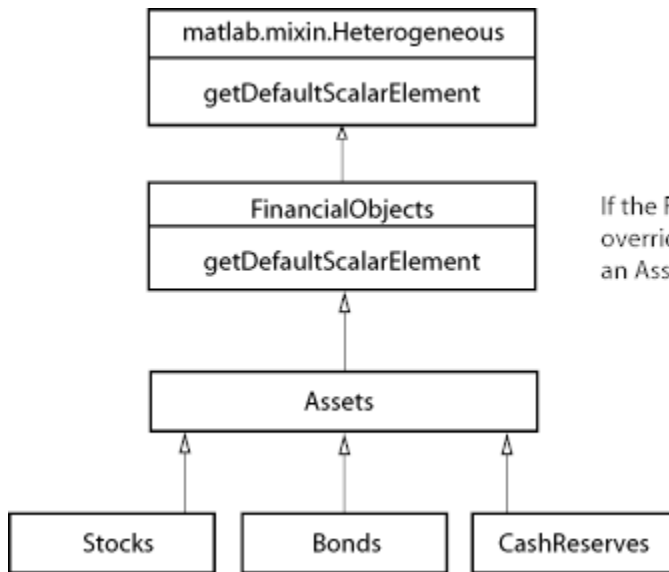

If the `FinancialObjects` class is abstract, override `getDefaultScalarElement` to return an `Assets` object as the default object.

The root class can override the `getDefaultScalarElement` method that is defined in `matlab.mixin.Heterogeneous` class and return an `Assets` object as the default object.

```
classdef FinancialObjects < matlab.mixin.Heterogeneous
 methods (Abstract)
 val = determineCurrentValue(obj)
 end
 methods (Static, Sealed, Access = protected)
 function default_object = getDefaultScalarElement
 default_object = Assets;
 end
 end
end
```

## See Also

`matlab.mixin.Heterogeneous`

# matlab.mixin.Heterogeneous.horzcat

---

**Purpose** Horizontal concatenation for heterogeneous arrays

**Syntax** `C = horzcat(A1,A2,...)`

**Description** `C = horzcat(A1,A2,...)` concatenates the `matlab.mixin.Heterogeneous` objects `A1`, `A2`, and so on, to form the array `C`. All input arrays must have the same number of rows.

The class of object arrays `A1,A2,...` must be derived from the same root class of a `matlab.mixin.Heterogeneous` hierarchy.

MATLAB calls:

```
C = horzcat(A1,A2,...)
```

for the expressions:

```
C = [A1,A2,...]
```

```
C = [A1 A2 ...]
```

when `A1` is an array of `matlab.mixin.Heterogeneous` objects.

If all input arguments are of the same specific class, the class of the resulting array is unchanged. If all input arguments are of different subclasses of a common superclass that is derived from `matlab.mixin.Heterogeneous`, then the result is a heterogeneous array. The array's class is that of the most specific superclass shared by all input arguments.

If all input arguments are not members of the same heterogeneous hierarchy, MATLAB calls the `convertObjects` method, if defined by the dominant root class (the first argument or the left-most element in the concatenation if no other class is dominant).

The `horzcat` method is sealed in the class `matlab.mixin.Heterogeneous` and, therefore, you cannot override it in subclasses.

## Input Arguments

**A1**

Object array of class `matlab.mixin.Heterogeneous`

**A2**

Object array of class `matlab.mixin.Heterogeneous`

## Output Arguments

**C**

Array resulting from the specified concatenation. The class of this array is that of the most specific superclass shared by the input arguments.

## Attributes

Sealed

true

To learn about attributes of methods, see [Method Attributes](#) in the MATLAB Object-Oriented Programming documentation.

## See Also

`matlab.mixin.Heterogeneous` | `horzcat`

# matlab.mixin.Heterogeneous.vertcat

---

**Purpose** Vertical concatenation for heterogeneous arrays

**Syntax** `C = vertcat(A1,A2,...)`

**Description** `C = vertcat(A1,A2,...)` concatenates the `matlab.mixin.Heterogeneous` objects `A1`, `A2`, and so on, to form the array `C`. All input arrays must have the same number of columns.

The class of object arrays `A1,A2,...` must be derived from the same root class of a `matlab.mixin.Heterogeneous` hierarchy.

MATLAB calls:

```
C = vertcat(A1,A2,...)
```

for the expression:

```
C = [A1;A2;...]
```

when `A1` and `A2`, and so on are arrays of `matlab.mixin.Heterogeneous` objects.

If all input arguments are of the same specific class, the class of the resulting array is unchanged. If all input arguments are of different subclasses of a common superclass that is derived from `matlab.mixin.Heterogeneous`, then the result is a heterogeneous array. The array's class is that of the most specific superclass shared by all input arguments.

If all input arguments are not members of the same heterogeneous hierarchy, MATLAB calls the `convertObjects` method, if defined by the dominant root class (the first argument or the left-most element in the concatenation if no other class is dominant).

The `horzcat` method is sealed in the class `matlab.mixin.Heterogeneous` and, therefore, you cannot override it in subclasses.

## Input Arguments

**A1**

Object array of class `matlab.mixin.Heterogeneous`

**A2**

Object array of class `matlab.mixin.Heterogeneous`

## Output Arguments

**C**

Array resulting from the specified vertical concatenation. The class of this array is that of the most specific superclass shared by the input arguments.

## Attributes

Sealed

true

To learn about attributes of methods, see [Method Attributes](#) in the MATLAB Object-Oriented Programming documentation.

## See Also

`matlab.mixin.Heterogeneous` | `vertcat`

# hex2dec

---

**Purpose** Convert hexadecimal number string to decimal number

**Syntax** `d = hex2dec('hex_value')`

**Description** `d = hex2dec('hex_value')` converts *hex\_value* to its floating-point integer representation. The argument *hex\_value* is a hexadecimal integer stored in a MATLAB string or cell array of strings. The value of *hex\_value* must be smaller than hexadecimal 10,000,000,000,000.

If *hex\_value* is a cell array of strings, each row is interpreted as a hexadecimal string.

**Examples** `hex2dec('3ff')`

```
ans =
```

```
 1023
```

For a character array S,

```
S =
```

```
0FF
```

```
2DE
```

```
123
```

```
hex2dec(S)
```

```
ans =
```

```
255
```

```
734
```

```
291
```

**See Also** `dec2hex` | `format` | `hex2num` | `sprintf`



**Purpose** Convert hexadecimal number string to double-precision number

**Syntax** `n = hex2num(S)`

**Description** `n = hex2num(S)`, where `S` is a 16 character string or cell array of strings representing a hexadecimal number, returns the IEEE double-precision floating-point number `n` that it represents. Fewer than 16 characters are padded on the right with zeros. If `S` is a cell array of strings, each row is interpreted as a double-precision number.

NaNs, infinities and denorms are handled correctly.

**Examples** `hex2num('400921fb54442d18')`

returns `Pi`.

`hex2num('bff')`

returns

`ans =`

`-1`

**See Also** `num2hex` | `hex2dec` | `sprintf` | `format`

# hgexport

---

**Purpose** Export figure

**Syntax** hgexport(h,filename)  
hgexport(h,'-clipboard')

**Description** hgexport(h,filename) writes figure h to the file filename.  
hgexport(h,'-clipboard') writes figure h to the Microsoft Windows clipboard.

The format in which the figure is exported is determined by which renderer you use. The Painters renderer generates a metafile. The ZBuffer and OpenGL renderers generate a bitmap.

**Alternatives** Use the **File > Export Setup** dialog. Use **Edit > Copy Figure** to copy the figure's content to the system clipboard. For details, see How to Print or Export.

**See Also** print

|                    |                                                                                                                                                                                                                                                                                                                                                                                                                                                                                                                                                                                                                                                                                                                                                                                                                                                                                                                                                                                                                                                                                                                                                                                                                                                                                           |
|--------------------|-------------------------------------------------------------------------------------------------------------------------------------------------------------------------------------------------------------------------------------------------------------------------------------------------------------------------------------------------------------------------------------------------------------------------------------------------------------------------------------------------------------------------------------------------------------------------------------------------------------------------------------------------------------------------------------------------------------------------------------------------------------------------------------------------------------------------------------------------------------------------------------------------------------------------------------------------------------------------------------------------------------------------------------------------------------------------------------------------------------------------------------------------------------------------------------------------------------------------------------------------------------------------------------------|
| <b>Purpose</b>     | Create hggroup object                                                                                                                                                                                                                                                                                                                                                                                                                                                                                                                                                                                                                                                                                                                                                                                                                                                                                                                                                                                                                                                                                                                                                                                                                                                                     |
| <b>Syntax</b>      | <pre>h = hggroup h = hggroup(..., 'PropertyName', propertyvalue, ...)</pre>                                                                                                                                                                                                                                                                                                                                                                                                                                                                                                                                                                                                                                                                                                                                                                                                                                                                                                                                                                                                                                                                                                                                                                                                               |
| <b>Properties</b>  | For a list of properties, see <code>Hggroup Properties</code> .                                                                                                                                                                                                                                                                                                                                                                                                                                                                                                                                                                                                                                                                                                                                                                                                                                                                                                                                                                                                                                                                                                                                                                                                                           |
| <b>Description</b> | <p><code>h = hggroup</code> creates an hggroup object as a child of the current axes and returns its handle, <code>h</code>.</p> <p><code>h = hggroup(..., 'PropertyName', propertyvalue, ...)</code> creates an hggroup object with the property values specified in the argument list. For a description of the properties, see <code>Hggroup Properties</code>.</p> <p>An hggroup object can be the parent of any axes children except light objects, as well as other hggroup objects. You can use hggroup objects to form a group of objects that can be treated as a single object with respect to the following cases:</p> <ul style="list-style-type: none"><li>• <b>Visible</b> — Setting the hggroup object's <code>Visible</code> property also sets each child object's <code>Visible</code> property to the same value.</li><li>• <b>Selectable</b> — Setting each hggroup child object's <code>HitTest</code> property to <code>off</code> enables you to select all children by clicking any child object.</li><li>• <b>Current object</b> — Setting each hggroup child object's <code>HitTest</code> property to <code>off</code> enables the hggroup object to become the current object when any child object is picked. See the next section for an example.</li></ul> |
| <b>Examples</b>    | <p>This example defines a callback for the <code>ButtonDownFcn</code> property of an hggroup object. In order for the hggroup to receive the mouse button down event that executes the <code>ButtonDownFcn</code> callback, the <code>HitTest</code> properties of all the line objects must be set to <code>off</code>. The event is then passed up the hierarchy to the hggroup.</p> <p>The following function creates a random set of lines that are parented to an hggroup object. The local function <code>set_lines</code> defines a callback that executes when the mouse button is pressed over any of the lines.</p>                                                                                                                                                                                                                                                                                                                                                                                                                                                                                                                                                                                                                                                             |

# hgroup

The callback simply increases the widths of all the lines by 1 with each button press.

---

**Note** If you are using the MATLAB help browser, you can run this example or open it in the MATLAB editor.

---

```
function doc_hgroup
hg = hgroup('ButtonDownFcn',@set_lines);
hl = line(randn(5),randn(5),'HitTest','off','Parent',hg);

function set_lines(cb,eventdata)
hl = get(cb,'Children');% cb is handle of hgroup object
lw = get(hl,'LineWidth');% get current line widths
set(hl,{'LineWidth'},num2cell([lw{:}]+1,[5,1]))
```

Note that selecting any one of the lines selects all the lines. (To select an object, enable plot edit mode by selecting **Plot Edit** from the **Tools** menu.)

## Instance Diagram for This Example

The following diagram shows the object hierarchy created by this example.

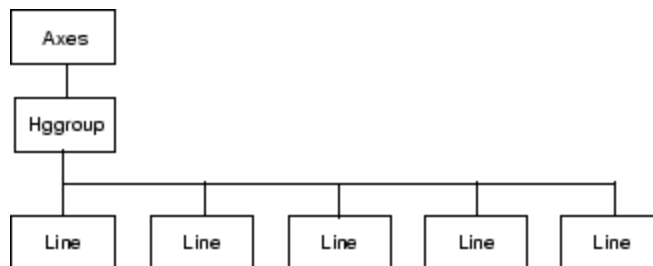

## Setting Default Properties

You can set default hggroup properties on the axes, figure, and root object levels:

```
set(0, 'DefaultHggroupProperty', PropertyValue...)
set(gcf, 'DefaultHggroupProperty', PropertyValue...)
set(gca, 'DefaultHggroupProperty', PropertyValue...)
```

where *Property* is the name of the hggroup property whose default value you want to set and *PropertyValue* is the value you are specifying. Use `set` and `get` to access the hggroup properties.

## See Also

[hgtransform](#) | [Hggroup Properties](#)

## How To

- “Group Objects”
- “Function Handle Callbacks”

# Hgggroup Properties

---

## Purpose

Hgggroup properties

## Creating Hgggroup Objects

Use `hggroup` to create hgggroup objects.

## Modifying Properties

You can set and query graphics object properties using the `set` and `get` commands.

To change the default values of properties, see “Setting Default Property Values”.

See “Group Objects” for general information on this type of object.

## Hgggroup Property Descriptions

This section provides a description of properties. Curly braces { } enclose default values.

### Annotation

`hg.Annotation` object (read-only)

*Control the display of hgggroup objects in legends.* Specifies whether this hgggroup object is represented in a figure legend.

Querying the `Annotation` property returns the handle of an `hg.Annotation` object. The `hg.Annotation` object has a property called `LegendInformation`, which contains an `hg.LegendEntry` object.

Once you have obtained the `hg.LegendEntry` object, you can set its `IconDisplayStyle` property to control whether the hgggroup object is displayed in a figure legend.

| <b>IconDisplayStyle Value</b> | <b>Purpose</b>                                                                     |
|-------------------------------|------------------------------------------------------------------------------------|
| on                            | Include the hgggroup object in a legend as one entry, but not its children objects |
| off                           | Do not include the hgggroup or its children in a legend (default)                  |
| children                      | Include only the children of the hgggroup as separate entries in the legend        |

## Setting the IconDisplayStyle Property

These commands set the `IconDisplayStyle` of a graphics object with handle `hobj` to `children`, which causes each child object to have an entry in the legend:

```
hAnnotation = get(hobj, 'Annotation');
hLegendEntry = get(hAnnotation, 'LegendInformation');
set(hLegendEntry, 'IconDisplayStyle', 'children')
```

## Using the IconDisplayStyle Property

See “Control Legend Content” for more information and examples.

### BeingDeleted

on | {off} (read-only)

*This object is being deleted.* Mechanism to determine if objects are in the process of being deleted. MATLAB sets the `BeingDeleted` property to `on` when the object’s delete function callback is called (see the `DeleteFcn` property). It remains set to `on` while the delete function executes, after which the object no longer exists.

For example, an object’s delete function calls other functions that act on a number of different objects. If a function does not need to perform an action on an about-be-deleted object, it can check the object’s `BeingDeleted` property before acting.

# Hgroup Properties

---

`BusyAction`  
cancel | {queue}

## *Callback queuing*

Determines how MATLAB handles the execution of interrupting callbacks.

A *running* callback is the currently executing callback. The *interrupting* callback is the callback that tries to interrupt the *running* callback. The `BusyAction` property of the *interrupting* callback determines how MATLAB handles its execution. When the `BusyAction` property is set to:

- 'queue' — Puts the *interrupting* callback in a queue to be processed after the *running* callback finishes execution.
- 'cancel' — Discards the *interrupting* callback as MATLAB finishes execution.

For information about how the `Interruptible` property of the callback controls whether other callbacks can interrupt the *running* callback, see the `Interruptible` property description.

`ButtonDownFcn`  
function handle | cell array containing function handle and additional arguments | string (not recommended)

*Button press callback function.* Executes whenever you press a mouse button while the pointer is over the children of the hgroup object. Define the `ButtonDownFcn` as a function handle. The function must define at least two input arguments (handle of figure associated with the mouse button press and an empty event structure).

For information on the syntax of callback functions, see [Function Handle Callbacks](#).



## Children

array of graphics object handles

*Children of the hggroup object.* An array containing the handles of all objects parented to the hggroup object (whether visible or not).

Note that if a child object's `HandleVisibility` property is `callback` or `off`, its handle does not appear in the hggroup `Children` property unless you set the `Root ShowHiddenHandles` property to `on`:

```
set(0, 'ShowHiddenHandles', 'on')
```

## Clipping

{on} | off

*Clipping mode.* MATLAB clips stairs plots to the axes plot box by default. If you set `Clipping` to `off`, lines might be displayed outside the axes plot box.

## CreateFcn

function handle | cell array containing function handle and additional arguments | string (not recommended)

*Callback executed during object creation.* Executes when MATLAB creates an hggroup object. You must define this property as a default value for hggroup objects or in a call to the hggroup function to create a new hggroup object. For example, the statement:

```
set(0, 'DefaultHggroupCreateFcn', @myCreateFcn)
```

defines a default value on the root level that applies to every hggroup object created in that MATLAB session. Whenever you create an hggroup object, the function associated with the function handle `@myCreateFcn` executes.

# Hggroup Properties

---

MATLAB executes the callback after setting all the hggroup object's properties. Setting the `CreateFcn` property on an existing hggroup object has no effect.

The handle of the object whose `CreateFcn` is being executed is passed by MATLAB as the first argument to the callback function and is also accessible through the root `CallbackObject` property, which you can query using `gcbo`.

See [Function Handle Callbacks](#) for information on how to use function handles to define the callback function.

## `DeleteFcn`

function handle | cell array containing function handle and additional arguments | string (not recommended)

*Callback executed during object deletion.* Executes when the hggroup object is deleted (for example, this might happen when you issue a `delete` command on the hggroup object, its parent axes, or the figure containing it). MATLAB executes the callback before destroying the object's properties so the callback routine can query these values.

The handle of the object whose `DeleteFcn` is being executed is passed by MATLAB as the first argument to the callback function and is accessible through the root `CallbackObject` property, which you can query using `gcbo`.

See ["Function Handle Callbacks"](#) for information on how to use function handles to define the callback function.

See the `BeingDeleted` property for related information.

`DisplayName`  
string

*String used by legend.* The `legend` function uses the `DisplayName` property to label the hgroup object in the legend. The default is an empty string.

- If you specify string arguments with the `legend` function, MATLAB set `DisplayName` to the corresponding string and uses that string for the legend.
- If `DisplayName` is empty, `legend` creates a string of the form, `['data' n]`, where `n` is the number assigned to the object based on its location in the list of legend entries. However, `legend` does not set `DisplayName` to this string.
- If you edit the string directly in an existing legend, MATLAB set `DisplayName` to the edited string.
- If you specify a string for the `DisplayName` property and create the legend using the figure toolbar, then MATLAB uses the string defined by `DisplayName`.
- To add a legend programmatically that uses the `DisplayName` string, call `legend` with the `toggle` or `show` option.

See “Control Legend Content” for more information and examples.

## EraseMode

`{normal} | none | xor | background`

*Erase mode.* This property controls the technique MATLAB uses to draw and erase hgroup child objects. Alternative erase modes are useful for creating animated sequences, where control of the way individual objects are redrawn is necessary to improve performance and obtain the desired effect.

- `normal` — Redraw the affected region of the display, performing the three-dimensional analysis necessary to ensure that all objects are rendered correctly. This mode produces the most accurate picture, but is the slowest. The other modes are faster, but do not perform a complete redraw and are therefore less accurate.

# Hgroup Properties

---

- **none** — Do not erase objects when they are moved or destroyed. While the objects are still visible on the screen after erasing with `EraseMode none`, you cannot print these objects because MATLAB stores no information about their former locations.
- **xor** — Draw and erase the object by performing an exclusive OR (XOR) with each pixel index of the screen behind it. Erasing the object does not damage the color of the objects behind it. However, the color of the erased object depends on the color of the screen behind it and it is correctly colored only when it is over the axes background color (or the figure background color if the axes `Color` property is `none`). That is, it isn't erased correctly if there are objects behind it.
- **background** — Erase the graphics objects by redrawing them in the axes background color, (or the figure background color if the axes `Color` property is `none`). This damages other graphics objects that are behind the erased object, but the erased object is always properly colored.

Set the axes background color with the axes `Color` property. Set the figure background color with the figure `Color` property.

## Printing with Nonnormal Erase Modes

MATLAB always prints figures as if the `EraseMode` of all objects is `normal`. This means graphics objects created with `EraseMode` set to `none`, `xor`, or `background` can look different on screen than on paper. On screen, MATLAB mathematically combines layers of colors (for example, performing an XOR on a pixel color with that of the pixel behind it) and ignore three-dimensional sorting to obtain greater rendering speed. However, these techniques are not applied to the printed output.

You can use the `getframe` command or other screen capture applications to create an image of a figure containing nonnormal mode objects.

## HandleVisibility

{on} | callback | off

*Control access to object's handle.* Determines when an object's handle is visible in its parent's list of children. `HandleVisibility` is useful for preventing command-line users from accidentally accessing the hgroup object.

- `on` — Handles are always visible.
- `callback` — Handles are visible from within callback routines or functions invoked by callback routines, but not from within functions invoked from the command line. This provides a means to protect GUIs from command-line users, while allowing callback routines to have access to object handles.
- `off` — Handles are invisible at all times. Use this option when a callback invokes a function that could damage the GUI (such as evaluating a user-typed string). This option temporarily hides its own handles during the execution of that function.

## Functions Affected by Handle Visibility

When a handle is not visible in its parent's list of children, it cannot be returned by functions that obtain handles by searching the object hierarchy or querying handle properties. This includes `get`, `findobj`, `gca`, `gcf`, `gco`, `newplot`, `cla`, `clf`, and `close`.

## Properties Affected by Handle Visibility

When a handle's visibility is restricted using `callback` or `off`, the object's handle does not appear in its parent's `Children` property, figures do not appear in the root's `CurrentFigure` property, objects do not appear in the root's `CallbackObject` property or in the figure's `CurrentObject` property, and axes do not appear in their parent's `CurrentAxes` property.

## Overriding Handle Visibility

# Hgroup Properties

---

You can set the root `ShowHiddenHandles` property to `on` to make all handles visible regardless of their `HandleVisibility` settings (this does not affect the values of the `HandleVisibility` properties). See also `findall`.

## Handle Validity

Handles that are hidden are still valid. If you know an object's handle, you can `set` and `get` its properties, and pass it to any function that operates on handles.

`HitTest`  
`{on} | off`

*Selectable by mouse click.* `HitTest` determines whether the hgroup object can become the current object (as returned by the `gco` command and the figure `CurrentObject` property) as a result of a mouse click on the hgroup child objects. Note that to pick the hgroup object, its children must have their `HitTest` property set to `off`.

If the hgroup object's `HitTest` is `off`, clicking it picks the object behind it.

`Interruptible`  
`off | {on}`

*Callback routine interruption*

Controls whether MATLAB can interrupt an object's callback function when subsequent callbacks attempt to interrupt it.

For Graphics objects, the `Interruptible` property affects only the callbacks for the `ButtonDownFcn` property. A *running* callback is the currently executing callback. The *interrupting* callback is the callback that tries to interrupt the *running* callback. MATLAB handles both the callbacks based on the `Interruptible` property of the object of the *running* callback.

When the `Interruptible` property is set to:

- 'off', MATLAB finishes execution of the *running* callback without any interruptions
- 'on', these conditions apply:
  - If there is a `drawnow`, `figure`, `getframe`, `waitfor`, or `pause` command in the *running* callback, then MATLAB executes the *interrupting* callbacks which are already in the queue and returns to finish execution of the current callback.
  - If one of the above functions is not in the *running* callback, then MATLAB finishes execution of the current callback without any interruption.

`BusyAction` property of the object of interrupting callback determines whether the callback should be ignored or should be put in the queue.

Setting `Interruptible` property to on (default), allows a callback from other graphics objects to interrupt callback functions originating from this object.

---

**Note** MATLAB does not save the state of properties or the display when an interruption occurs. For example, the handle returned by the `gca` or `gcf` command may be changed as another callback is executed.

---

After the function that interrupts a callback completes, the callback resumes execution where it halted when interrupted. For more information, see “Control Callback Execution and Interruption”.

Parent  
axes handle

# Hgroup Properties

---

*Parent of hgroup object.* This property contains the handle of the hgroup object's parent object. The parent of an hgroup object is the axes, hgroup, or hgtransform object that contains it.

Selected

on | {off}

*Is object selected?* When you set this property to on, MATLAB displays selection handles at the corners and midpoints of hgroup child objects if the SelectionHighlight property is also on (the default).

SelectionHighlight

{on} | off

*Objects are highlighted when selected.* When the Selected property is on, MATLAB indicates the selected state by drawing selection handles on the hgroup child objects. When SelectionHighlight is off, MATLAB does not draw the handles.

Tag

string

*User-specified object label.* Provides a means to identify graphics objects with a user-specified label. The default is an empty string.

Use the Tag property and the findobj function to manipulate specific objects within a plotting hierarchy.

For example, create an hgroup object and set the Tag property:

```
t = hgroup('Tag','group1')
```

When you want to access the object, use findobj to find its handle. For example:

```
h = findobj('Tag','group1');
```



## Type

string (read-only)

*Type of graphics object.* String that identifies the class of the graphics object. Use this property to find all objects of a given type within a plotting hierarchy. For hggroup objects, Type is 'hggroup'. The following statement finds all the hggroup objects in the current axes.

```
t = findobj(gca, 'Type', 'hggroup');
```

## UIContextMenu

handle of uicontextmenu object

*Associate a context menu with the hggroup object.* Assign this property the handle of a uicontextmenu object created in the hggroup object's figure. Use the uicontextmenu function to create the context menu. MATLAB displays the context menu whenever you right-click the hggroup object.

## UserData

array

*User-specified data.* Data you want to associate with the hggroup object (including cell arrays and structures). The default value is an empty array. MATLAB does not use this data, but you can access it using the set and get commands.

## Visible

{on} | off

*Visibility of hggroup object and its children.* By default, hggroup object visibility is on. This means all children of the hggroup are visible unless the child object's Visible property is off. Setting an hggroup object's Visible property to off also makes its children invisible.

## See Also

hggroup

# hgload

---

## Purpose

Load Handle Graphics object hierarchy from file

## Syntax

```
h = hgload('filename')
[h,old_prop_values] = hgload(...,property_structure)
hgload(...,'all')
```

## Description

`h = hgload('filename')` loads Handle Graphics objects and its children (if any) from the FIG-file specified by `filename` and returns handles to the top-level objects. If `filename` contains no extension, then the MATLAB software adds the `.fig` extension.

`[h,old_prop_values] = hgload(...,property_structure)` overrides the properties on the top-level objects stored in the FIG-file with the values in `property_structure`, and returns their previous values in `old_prop_values`.

`property_structure` must be a structure having field names that correspond to property names and values that are the new property values.

`old_prop_values` is a cell array equal in length to `h`, containing the old values of the overridden properties for each object. Each cell contains a structure having field names that are property names, each of which contains the original value of each property that has been changed. Any property specified in `property_structure` that is not a property of a top-level object in the FIG-file is not included in `old_prop_values`.

`hgload(...,'all')` overrides the default behavior, which does not reload nonserializable objects saved in the file. These objects include the default toolbars and default menus. This option is obsolete and will be removed in a future release.

Nonserializable objects (such as the default toolbars and the default menus) are normally not reloaded because they are loaded from different files at figure creation time. This allows revisions of the default menus and toolbars to occur without affecting existing FIG-files. Passing the string `all` to `hgload` ensures that any nonserializable objects contained in the file are also reloaded.

Note that, by default, `hgsave` excludes nonserializable objects from the FIG-file unless you use the `all` flag.

## **Alternatives**

Use the **File > Open** on the figure window menu to access figure files with the **Open** dialog.

## **See Also**

`hgsave` | `open`

# hgsave

---

**Purpose** Save Handle Graphics object hierarchy to file

**Syntax**

```
hgsave('filename')
hgsave(h,'filename')
hgsave(...,'all')
hgsave(...,'-v6')
hgsave(...,'-v7.3')
```

**Description** `hgsave('filename')` saves the current figure to a file named `filename`.

`hgsave(h,'filename')` saves the objects identified by the array of handles `h` to a file named `filename`. If you do not specify an extension for `filename`, then the extension `.fig` is appended. If `h` is a vector, none of the handles in `h` may be ancestors or descendents of any other handles in `h`.

`hgsave(...,'all')` overrides the default behavior, which does not save nonserializable objects. Nonserializable objects include the default toolbars and default menus. This allows revisions of the default menus and toolbars to occur without affecting existing FIG-files and also reduces the size of FIG-files. Passing the string `all` to `hgsave` ensures that nonserializable objects are also saved. This option is obsolete and will be removed in a future release.

The default behavior of `hgload` is to ignore nonserializable objects in the file at load time. You can override this behavior using the `all` argument with `hgload`.

`hgsave(...,'-v6')` saves the FIG-file in a format that can be loaded by versions prior to MATLAB 7.

`hgsave(...,'-v7.3')` saves the FIG-file in a format that can be loaded only by MATLAB versions 7.3 and above. This format, based on HDF5 files, is intended for saving FIG-files larger than 2 GB.

You can make `-v6` or `-v7.3` your default format for saving MAT-files and FIG-files by setting a preference, which will eliminate the need to specify the flag each time you save. See “MAT-Files Preferences” in the MATLAB Desktop Tools and Development Environment documentation.

## Full Backward Compatibility

When creating a figure you want to save and use in a MATLAB version prior to MATLAB 7, use the 'v6' option with the plotting function and the '-v6' option for hgsave. Check the reference page for the plotting function you are using for more information.

See “Plot Objects and Backward Compatibility” for more information.

## Alternatives

Use the **File > Export Setup** dialog. Use **Edit > Copy Figure** to copy the figure's content to the system clipboard. For details, see [How to Print or Export](#).

## See Also

hgload | open | save

# hgsetget

---

**Purpose** Abstract class used to derive handle class with set and get methods

**Syntax** `classdef myclass < hgsetget`

**Description** `classdef myclass < hgsetget` makes *myclass* a subclass of the `hgsetget` class, which is a subclass of the `handle` class.

Use the `hgsetget` class to derive classes that inherit `set` and `get` methods that behave like Handle Graphics `set` and `get` functions.

## Methods

When you derive a class from the `hgsetget` class, your class inherits the following methods.

| Method               | Purpose                                                                                                                                                                  |
|----------------------|--------------------------------------------------------------------------------------------------------------------------------------------------------------------------|
| <code>set</code>     | Assigns values to the specified properties or returns a cell array of possible values for writable properties.                                                           |
| <code>get</code>     | Returns value of specified property or a struct with all property values.                                                                                                |
| <code>setdisp</code> | Called when <code>set</code> is called with no output arguments and a handle array, but no property name. Override this method to change what <code>set</code> displays. |
| <code>getdisp</code> | Called when <code>get</code> is called with no output arguments and handle array, but no property name. Override this method to change what <code>get</code> displays.   |

**See Also** `handle` | `set (hgsetget)` | `get (hgsetget)` | `set` | `get`

**How To** • “Implementing a Set/Get Interface for Properties”

|                    |                                                                                                                                                                                                                                                                                                                                                                                                                                                                                                                                                                                                                                                                                                                                                                                                                                                                                                                                                                                                                                                                                                                                                                                                                                                                                                                                                                                                                                                                                                                                                    |
|--------------------|----------------------------------------------------------------------------------------------------------------------------------------------------------------------------------------------------------------------------------------------------------------------------------------------------------------------------------------------------------------------------------------------------------------------------------------------------------------------------------------------------------------------------------------------------------------------------------------------------------------------------------------------------------------------------------------------------------------------------------------------------------------------------------------------------------------------------------------------------------------------------------------------------------------------------------------------------------------------------------------------------------------------------------------------------------------------------------------------------------------------------------------------------------------------------------------------------------------------------------------------------------------------------------------------------------------------------------------------------------------------------------------------------------------------------------------------------------------------------------------------------------------------------------------------------|
| <b>Purpose</b>     | Create hgtransform graphics object                                                                                                                                                                                                                                                                                                                                                                                                                                                                                                                                                                                                                                                                                                                                                                                                                                                                                                                                                                                                                                                                                                                                                                                                                                                                                                                                                                                                                                                                                                                 |
| <b>Syntax</b>      | <pre>h = hgtransform h = hgtransform('PropertyName',propertyvalue,...)</pre>                                                                                                                                                                                                                                                                                                                                                                                                                                                                                                                                                                                                                                                                                                                                                                                                                                                                                                                                                                                                                                                                                                                                                                                                                                                                                                                                                                                                                                                                       |
| <b>Properties</b>  | For a list of properties, see Hgtransform Properties.                                                                                                                                                                                                                                                                                                                                                                                                                                                                                                                                                                                                                                                                                                                                                                                                                                                                                                                                                                                                                                                                                                                                                                                                                                                                                                                                                                                                                                                                                              |
| <b>Description</b> | <p><code>h = hgtransform</code> creates an hgtransform object and returns its handle.</p> <p><code>h = hgtransform('PropertyName',propertyvalue,...)</code> creates an hgtransform object with the property value settings specified in the argument list. For a description of the properties, see Hgtransform Properties.</p> <p>hgtransform objects can contain other objects, which lets you treat the hgtransform and its children as a single entity with respect to visibility, size, orientation, etc. You can group objects by parenting them to a single hgtransform object (i.e., setting the object's Parent property to the hgtransform object's handle):</p> <pre>h = hgtransform; surface('Parent',h,...)</pre> <p>The primary advantage of parenting objects to an hgtransform object is that you can perform <i>transforms</i> (for example, translation, scaling, rotation, etc.) on the child objects in unison.</p> <p>The parent of an hgtransform object is either an axes object or another hgtransform.</p> <p>Although you cannot see an hgtransform object, setting its Visible property to <code>off</code> makes all its children invisible as well.</p> <p><b>Exceptions and Limitations</b></p> <ul style="list-style-type: none"><li>• An hgtransform object can be the parent of any number of axes child objects belonging to the same axes, except for light objects.</li><li>• hgtransform objects can never be the parent of axes objects and therefore can contain objects only from a single axes.</li></ul> |

- hgtransform objects can be the parent of other hgtransform objects within the same axes.
- You cannot transform image objects because images are not true 3-D objects. Texture mapping the image data to a surface CData enables you to produce the effect of transforming an image in 3-D space.

---

**Note** Many plotting functions clear the axes (i.e., remove axes children) before drawing the graph. Clearing the axes also deletes any hgtransform objects in the axes.

---

## Examples

### Transforming a Group of Objects

This example shows how to create a 3-D star with a group of surface objects parented to a single hgtransform object. The hgtransform then rotates the object about the z-axis while scaling its size.

---

**Tip** If you are using the MATLAB Help browser, you can run this example or open it in the MATLAB Editor.

---

- 1 Create an axes and adjust the view. Set the axes limits to prevent auto limit selection during scaling.

```
ax = axes('XLim',[-1.5 1.5],'YLim',[-1.5 1.5],...
 'ZLim',[-1.5 1.5]);
view(3); grid on; axis equal
```

- 2 Create the objects you want to parent to the hgtransform object.

```
[x y z] = cylinder([.2 0]);
h(1) = surface(x,y,z,'FaceColor','red');
h(2) = surface(x,y,-z,'FaceColor','green');
h(3) = surface(z,x,y,'FaceColor','blue');
h(4) = surface(-z,x,y,'FaceColor','cyan');
```



```
h(5) = surface(y,z,x,'FaceColor','magenta');
h(6) = surface(y,-z,x,'FaceColor','yellow');
```

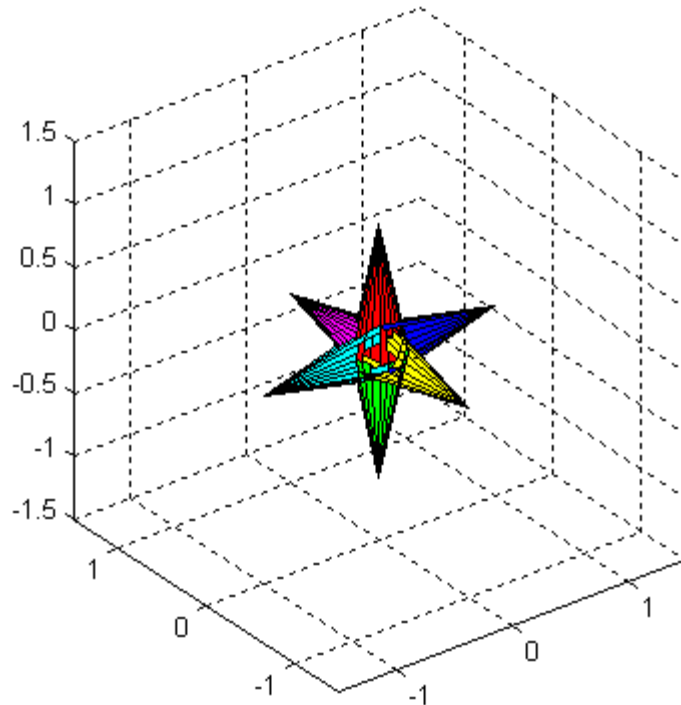

- 3** Create an hgtransform object and parent the surface objects to it. The figure should not change from the image above.

```
t = hgtransform('Parent',ax);
set(h,'Parent',t)
```

- 4** Select a renderer and show the objects.

```
set(gcf,'Renderer','opengl')
drawnow
```

# hgtransform

---

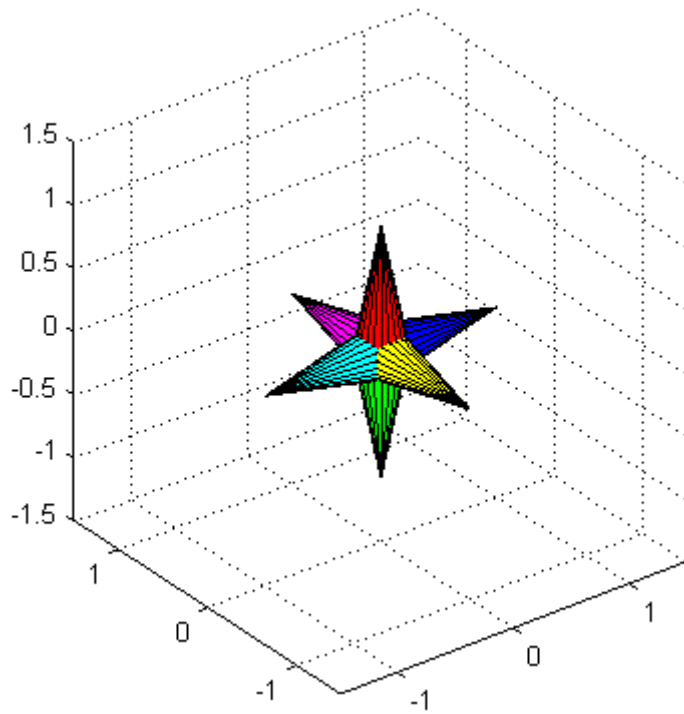

- 5 Initialize the rotation and scaling matrix to the identity matrix (`eye`). Again, the image should not change.

```
Rz = eye(4);
Sxy = Rz;
```

- 6 Form the  $z$ -axis rotation matrix and the scaling matrix. Rotate group and scale by using the increasing values of  $r$ .

```
for r = 1:.1:2*pi
 % Z-axis rotation matrix
 Rz = makehgtform('zrotate',r);
 % Scaling matrix
 Sxy = makehgtform('scale',r/4);
```

```
% Concatenate the transforms and
% set the hgtransform Matrix property
 set(t,'Matrix',Rz*Sxy)
 drawnow
end
pause(1)
```

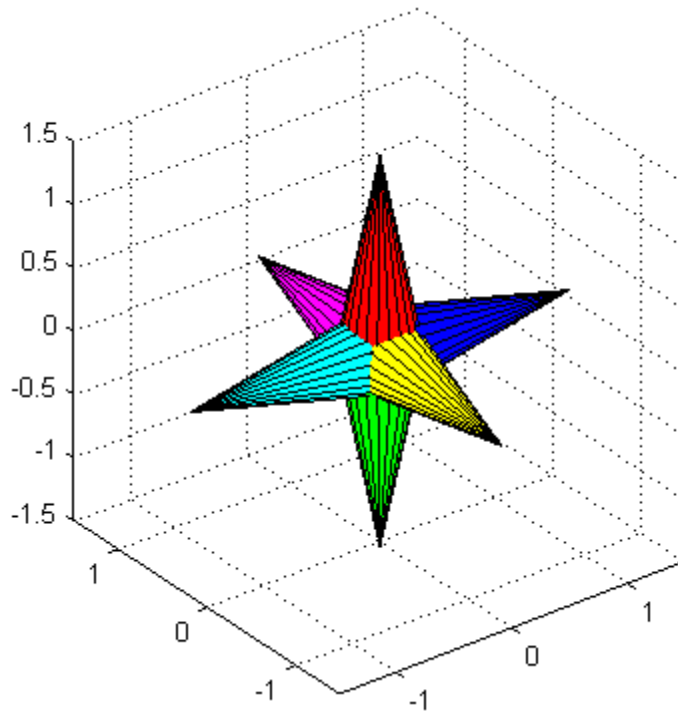

7 Reset to the original orientation and size using the identity matrix.

```
set(t,'Matrix',eye(4))
```

# hgtransform

---

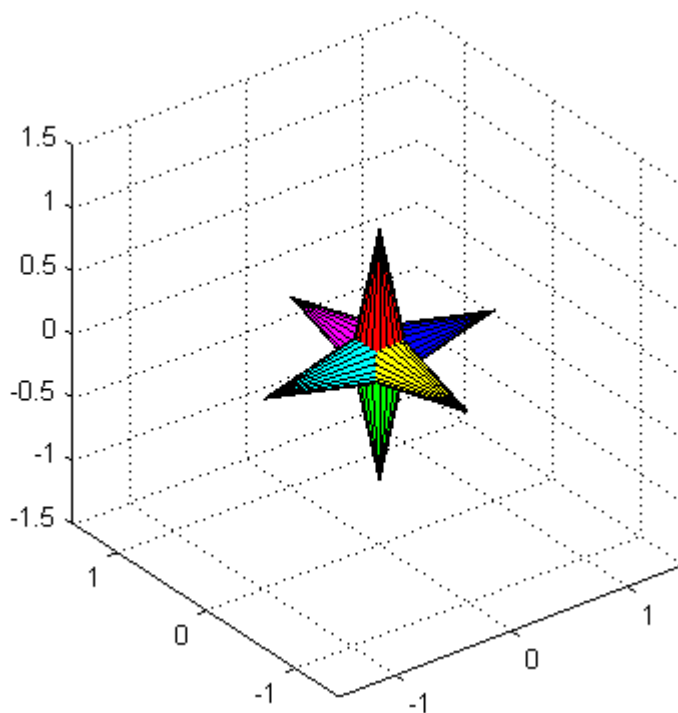

## Transforming Objects Independently

This example creates two `hgtransform` objects to illustrate how to transform each independently within the same axes. A translation transformation moves one `hgtransform` object away from the origin.

---

**Tip** If you are using the MATLAB Help browser, you can run this example or open it in the MATLAB Editor.

---

- 1 Create and set up the axes object that will be the parent of both `hgtransform` objects. Set the limits to accommodate the translated object.

```
ax = axes('XLim',[-2 1],'YLim',[-2 1],'ZLim',[-1 1]);
view(3); grid on; axis equal
```

**2** Create the surface objects to group.

```
[x y z] = cylinder([.3 0]);
h(1) = surface(x,y,z,'FaceColor','red');
h(2) = surface(x,y,-z,'FaceColor','green');
h(3) = surface(z,x,y,'FaceColor','blue');
h(4) = surface(-z,x,y,'FaceColor','cyan');
h(5) = surface(y,z,x,'FaceColor','magenta');
h(6) = surface(y,-z,x,'FaceColor','yellow');
```

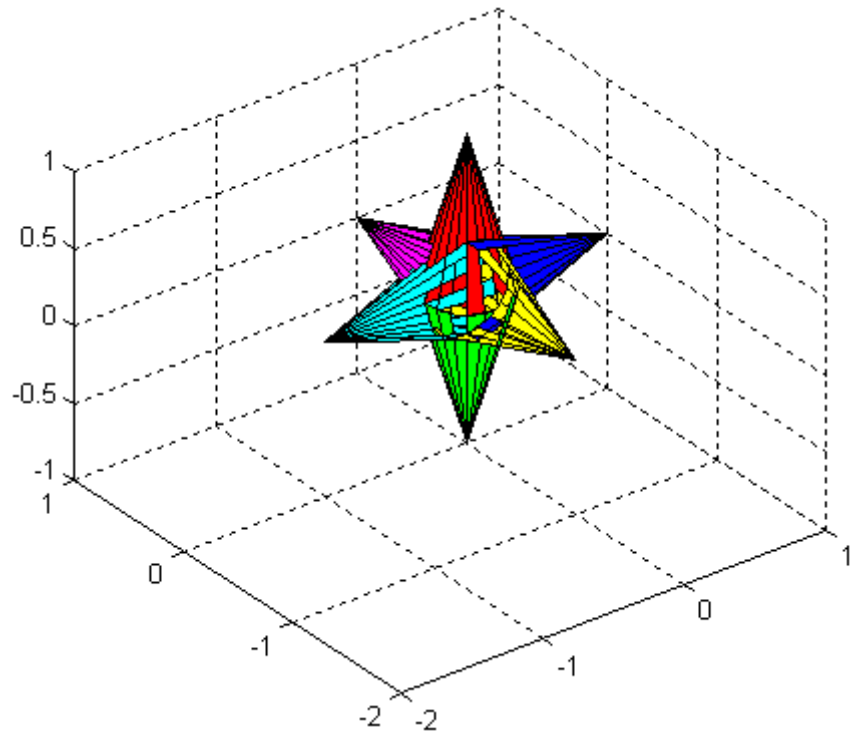

# hgtransform

---

- 3** Create the hgtransform objects and parent them to the same axes. The figure should not change.

```
t1 = hgtransform('Parent',ax);
t2 = hgtransform('Parent',ax);
```

- 4** Set the renderer to use OpenGL.

```
set(gcf,'Renderer','opengl')
```

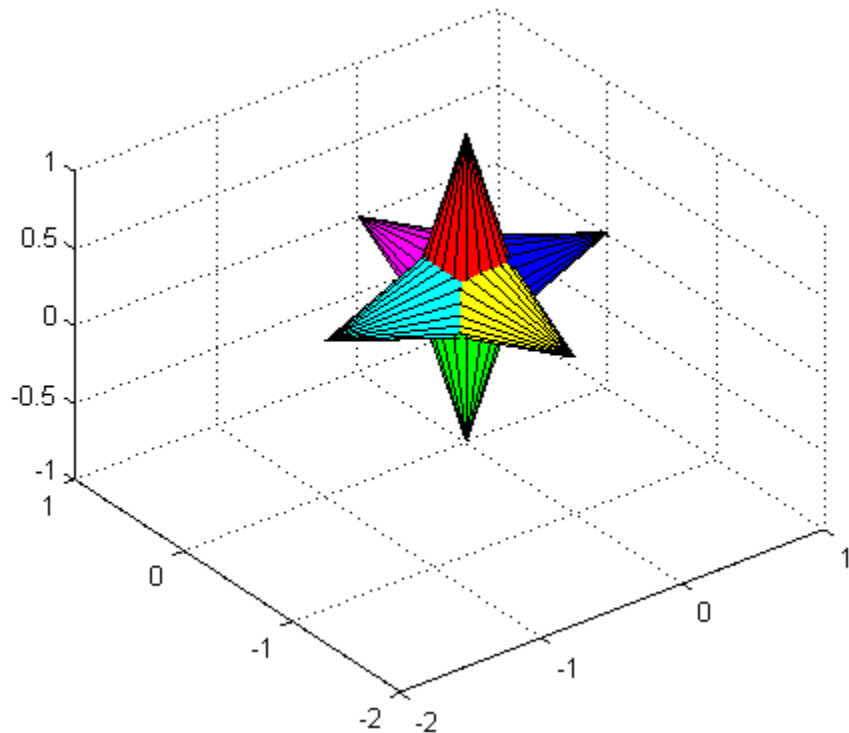

- 5** Parent the surfaces to hgtransform t1, then copy the surface objects and parent the copies to hgtransform t2. This figure should not change.

```
set(h, 'Parent', t1)
h2 = copyobj(h, t2);
```

- 6** Translate the second hgtransform object away from the first hgtransform object and display the result.

```
Txy = makehgtform('translate', [-1.5 -1.5 0]);
set(t2, 'Matrix', Txy)
drawnow
```

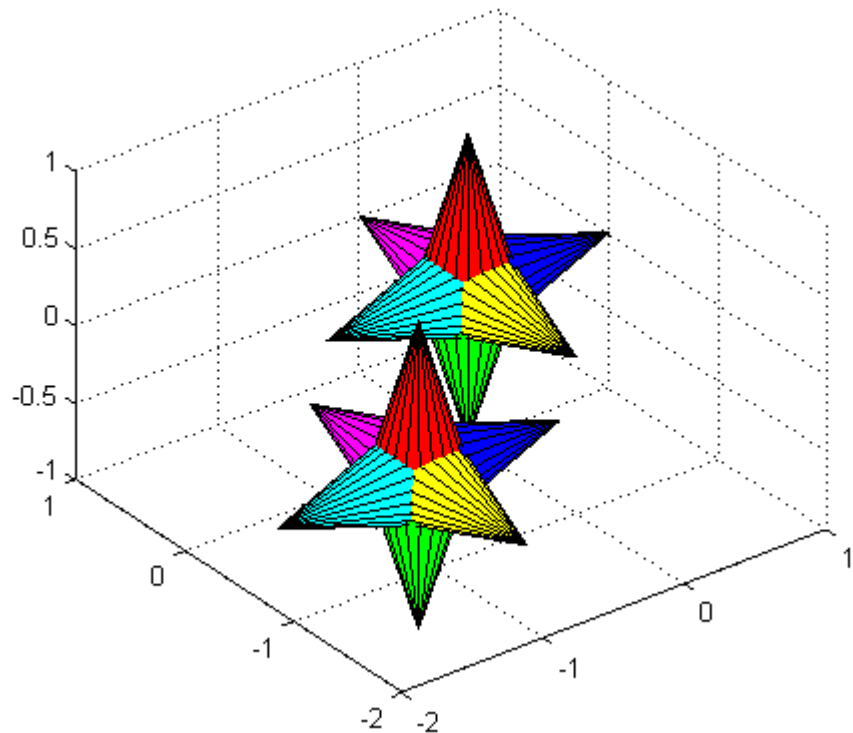

- 7** Rotate both hgtransform objects in opposite directions. The final image for this step is the same as for step 6. However, you should run the code to see the rotations.

# hgtransform

---

```
% Rotate 10 times (2pi radians = 1 rotation)
for r = 1:1:20*pi
 % Form z-axis rotation matrix
 Rz = makehgtform('zrotate',r);
 % Set transforms for both hgtransform objects
 set(t1,'Matrix',Rz)
 set(t2,'Matrix',Txy*inv(Rz))
 drawnow
end
```

## Setting Default Properties

You can set default hgtransform properties on the axes, figure, and root object levels:

```
set(0,'DefaultHgtransformPropertyName',propertyvalue,...)
set(gcf,'DefaultHgtransformPropertyName',propertyvalue,...)
set(gca,'DefaultHgtransformPropertyName',propertyvalue,...)
```

*PropertyName* is the name of the hgtransform property and *propertyvalue* is the specified value. Use `set` and `get` to access hgtransform properties.

## See Also

hggroup | makehgtform | Hgtransform Properties

## How To

- “Group Objects”



## Purpose

Hgtransform properties

## Creating Hgtransform Objects

Use `hgtransform` to create hgtransform objects.

## Modifying Properties

You can set and query graphics object properties using the `set` and `get` commands.

To change the default values of properties, see “Setting Default Property Values”.

See “Group Objects” for general information on this type of object.

## Hgtransform Property Descriptions

This section provides a description of properties. Curly braces { } enclose default values.

### Annotation

`hg.Annotation` object (read-only)

*Control the display of hgtransform objects in legends.* Specifies whether this hgtransform object is represented in a figure legend.

Querying the `Annotation` property returns the handle of an `hg.Annotation` object. The `hg.Annotation` object has a property called `LegendInformation`, which contains an `hg.LegendEntry` object.

Once you have obtained the `hg.LegendEntry` object, you can set its `IconDisplayStyle` property to control whether the hgtransform object is displayed in a figure legend.

# Hgtransform Properties

---

| <b>IconDisplayStyle Value</b> | <b>Purpose</b>                                                                        |
|-------------------------------|---------------------------------------------------------------------------------------|
| on                            | Include the hgtransform object in a legend as one entry, but not its children objects |
| off                           | Do not include the hgtransform or its children in a legend (default)                  |
| children                      | Include only the children of the hgtransform as separate entries in the legend        |

## Setting the IconDisplayStyle Property

These commands set the `IconDisplayStyle` of a graphics object with handle `hobj` to `children`, which causes each child object to have an entry in the legend:

```
hAnnotation = get(hobj, 'Annotation');
hLegendEntry = get(hAnnotation, 'LegendInformation');
set(hLegendEntry, 'IconDisplayStyle', 'children')
```

## Using the IconDisplayStyle Property

See “Control Legend Content” for more information and examples.

## BeingDeleted

on | {off} (read-only)

*This object is being deleted.* Mechanism to determine if objects are in the process of being deleted. MATLAB sets the `BeingDeleted` property to `on` when the object’s delete function callback is called (see the `DeleteFcn` property). It remains set to `on` while the delete function executes, after which the object no longer exists.

For example, an object’s delete function calls other functions that act on a number of different objects. If a function does not need to perform an action on an about-be-deleted object, it can check the object’s `BeingDeleted` property before acting.

**BusyAction**  
cancel | {queue}

### *Callback queuing*

Determines how MATLAB handles the execution of interrupting callbacks.

A *running* callback is the currently executing callback. The *interrupting* callback is the callback that tries to interrupt the *running* callback. The **BusyAction** property of the *interrupting* callback determines how MATLAB handles its execution. When the **BusyAction** property is set to:

- 'queue' — Puts the *interrupting* callback in a queue to be processed after the *running* callback finishes execution.
- 'cancel' — Discards the *interrupting* callback as MATLAB finishes execution.

For information about how the **Interruptible** property of the callback controls whether other callbacks can interrupt the *running* callback, see the **Interruptible** property description.

**ButtonDownFcn**  
function handle | cell array containing function handle and additional arguments | string (not recommended)

*Button press callback function.* Executes whenever you press a mouse button while the pointer is within the extent of the hgtransform object, but not over another graphics object. The extent of an hgtransform object is the smallest rectangle that encloses all the children. Note that you cannot execute the hgtransform object's button down function if it has no children.

Define the **ButtonDownFcn** as a function handle. The function must define at least two input arguments (handle of figure

# Hgtransform Properties

---

associated with the mouse button press and an empty event structure).

For information on the syntax of callback functions, see [Function Handle Callbacks](#).

## Children

array of graphics object handles

*Children of the hgtransform object.* An array containing the handles of all graphics objects parented to the hgtransform object (whether visible or not).

The graphics objects that can be children of an hgtransform are images, lights, lines, patches, rectangles, surfaces, and text. You can change the order of the handles and thereby change the stacking of the objects on the display.

Note that if a child object's `HandleVisibility` property is `callback` or `off`, its handle does not show up in the hgtransform `Children` property unless you set the `Root ShowHiddenHandles` property to `on`.

## Clipping

{on} | off

*Clipping mode.* This property has no effect on hgtransform objects.

## CreateFcn

function handle | cell array containing function handle and additional arguments | string (not recommended)

*Callback executed during object creation.* Executes when MATLAB creates an hgtransform object. You must define this property as a default value for hgtransform objects. For example, the statement:

```
set(0, 'DefaultHgtransformCreateFcn', @myCreateFcn)
```

defines a default value on the root level that applies to every hgtransform object created in a MATLAB session. Whenever you create an hgtransform object, the function associated with the function handle `@myCreateFcn` executes.

MATLAB executes the callback after setting all the hgtransform object's properties. Setting the `CreateFcn` property on an existing hgtransform object has no effect.

The handle of the object whose `CreateFcn` is being executed is passed by MATLAB as the first argument to the callback function and is accessible through the root `CallbackObject` property, which you can query using `gcbo`.

See “Function Handle Callbacks” for information on how to use function handles to define the callback function.

## DeleteFcn

function handle | cell array containing function handle and additional arguments | string (not recommended)

*Callback executed during object deletion.* Executes when the hgtransform object is deleted (for example, this might happen when you issue a `delete` command on the hgtransform object, its parent axes, or the figure containing it). MATLAB executes the callback before destroying the object's properties so the callback routine can query these values.

The handle of the object whose `DeleteFcn` is being executed is passed by MATLAB as the first argument to the callback function and is accessible through the root `CallbackObject` property, which can be queried using `gcbo`.

See “Function Handle Callbacks” for information on how to use function handles to define the callback function.

See the `BeingDeleted` property for related information.

# Hgtransform Properties

---

DisplayName  
string

*String used by legend.* The `legend` function uses the `DisplayName` property to label the `hgtransform` object in the legend. The default is an empty string.

- If you specify string arguments with the `legend` function, MATLAB set `DisplayName` to the corresponding string and uses that string for the legend.
- If `DisplayName` is empty, `legend` creates a string of the form, `['data' n]`, where `n` is the number assigned to the object based on its location in the list of legend entries. However, `legend` does not set `DisplayName` to this string.
- If you edit the string directly in an existing legend, MATLAB set `DisplayName` to the edited string.
- If you specify a string for the `DisplayName` property and create the legend using the figure toolbar, then MATLAB uses the string defined by `DisplayName`.
- To add a legend programmatically that uses the `DisplayName` string, call `legend` with the `toggle` or `show` option.

See “Control Legend Content” for more information and examples.

EraseMode  
{normal} | none | xor | background

*Erase mode.* This property controls the technique MATLAB uses to draw and erase `hgtransform` child objects (light objects have no erase mode). Alternative erase modes are useful for creating animated sequences, where control of the way individual objects are redrawn is necessary to improve performance and obtain the desired effect.

- `normal` — Redraw the affected region of the display, performing the three-dimensional analysis necessary to ensure that all

objects are rendered correctly. This mode produces the most accurate picture, but is the slowest. The other modes are faster, but do not perform a complete redraw and are therefore less accurate.

- **none** — Do not erase objects when they are moved or destroyed. While the objects are still visible on the screen after erasing with `EraseMode none`, you cannot print these objects because MATLAB stores no information about their former locations.
- **xor**— Draw and erase the object by performing an exclusive OR (XOR) with each pixel index of the screen behind it. Erasing the object does not damage the color of the objects behind it. However, the color of the erased object depends on the color of the screen behind it and it is correctly colored only when it is over the axes background color (or the figure background color if the axes `Color` property is `none`). That is, it isn't erased correctly if there are objects behind it.
- **background** — Erase the graphics objects by redrawing them in the axes background color, (or the figure background color if the axes `Color` property is `none`). This damages other graphics objects that are behind the erased object, but the erased object is always properly colored.

Set the axes background color with the axes `Color` property.

Set the figure background color with the figure `Color` property.

## Printing with Nonnormal Erase Modes

MATLAB always prints figures as if the `EraseMode` of all objects is `normal`. This means graphics objects created with `EraseMode` set to `none`, `xor`, or `background` can look different on screen than on paper. On screen, MATLAB mathematically combines layers of colors (for example, performing an XOR on a pixel color with that of the pixel behind it) and ignore three-dimensional sorting to obtain greater rendering speed. However, these techniques are not applied to the printed output.

# Hgtransform Properties

---

You can use the `getframe` command or other screen capture applications to create an image of a figure containing nonnormal mode objects.

## HandleVisibility

{on} | callback | off

*Control access to object's handle.* Determines when an object's handle is visible in its parent's list of children. `HandleVisibility` is useful for preventing command-line users from accidentally accessing the hgtransform object.

- `on` — Handles are always visible.
- `callback` — Handles are visible from within callback routines or functions invoked by callback routines, but not from within functions invoked from the command line. This provides a means to protect GUIs from command-line users, while allowing callback routines to have access to object handles.
- `off` — Handles are invisible at all times. Use this option when a callback invokes a function that could damage the GUI (such as evaluating a user-typed string). This option temporarily hides its own handles during the execution of that function.

## Functions Affected by Handle Visibility

When a handle is not visible in its parent's list of children, it cannot be returned by functions that obtain handles by searching the object hierarchy or querying handle properties. This includes `get`, `findobj`, `gca`, `gcf`, `gco`, `newplot`, `cla`, `clf`, and `close`.

## Properties Affected by Handle Visibility

When a handle's visibility is restricted using `callback` or `off`, the object's handle does not appear in its parent's `Children` property, figures do not appear in the root's `CurrentFigure` property, objects do not appear in the root's `CallbackObject` property or in



the figure's `CurrentObject` property, and axes do not appear in their parent's `CurrentAxes` property.

## Overriding Handle Visibility

You can set the root `ShowHiddenHandles` property to `on` to make all handles visible regardless of their `HandleVisibility` settings (this does not affect the values of the `HandleVisibility` properties). See also `findall`.

## Handle Validity

Handles that are hidden are still valid. If you know an object's handle, you can `set` and `get` its properties and pass it to any function that operates on handles.

`HitTest`  
`{on} | off`

*Selectable by mouse click.* `HitTest` determines whether the `hgtransform` object can become the current object (as returned by the `gco` command and the figure `CurrentObject` property) as a result of a mouse click within the limits of the `hgtransform` object. If `HitTest` is `off`, clicking the `hgtransform` picks the object behind it.

`Interruptible`  
`off | {on}`

*Callback routine interruption*

Controls whether MATLAB can interrupt an object's callback function when subsequent callbacks attempt to interrupt it.

For Graphics objects, the `Interruptible` property affects only the callbacks for the `ButtonDownFcn` property. A *running* callback is the currently executing callback. The *interrupting* callback is the callback that tries to interrupt the *running* callback. MATLAB

# Hgtransform Properties

---

handles both the callbacks based on the `Interruptible` property of the object of the *running* callback.

When the `Interruptible` property is set to:

- 'off', MATLAB finishes execution of the *running* callback without any interruptions
- 'on', these conditions apply:
  - If there is a `drawnow`, `figure`, `getframe`, `waitfor`, or `pause` command in the *running* callback, then MATLAB executes the *interrupting* callbacks which are already in the queue and returns to finish execution of the current callback.
  - If one of the above functions is not in the *running* callback, then MATLAB finishes execution of the current callback without any interruption.

`BusyAction` property of the object of interrupting callback determines whether the callback should be ignored or should be put in the queue.

Setting `Interruptible` property to on (default), allows a callback from other graphics objects to interrupt callback functions originating from this object.

---

**Note** MATLAB does not save the state of properties or the display when an interruption occurs. For example, the handle returned by the `gca` or `gcf` command may be changed as another callback is executed.

---

After the function that interrupts a callback completes, the callback resumes execution where it halted when interrupted. For more information, see “Control Callback Execution and Interruption”.

## Matrix

4-by-4 matrix

*Transformation matrix applied to hgtransform object and its children.* The hgtransform object applies the transformation matrix to all its children.

See “Group Objects” for more information and examples.

## Parent

figure handle

*Parent of hgtransform object.* This property contains the handle of the hgtransform object’s parent object. The parent of an hgtransform object is the axes, hggroup, or hgtransform object that contains it.

## Selected

on | {off}

*Is object selected?* When you set this property to on, MATLAB displays selection handles on all child objects of the hgtransform if the SelectionHighlight property is also on (the default).

## SelectionHighlight

{on} | off

*Objects are highlighted when selected.* When the Selected property is on, MATLAB indicates the selected state by drawing selection handles on the objects parented to the hgtransform. When SelectionHighlight is off, MATLAB does not draw the handles.

## Tag

string

*User-specified object label.* Provides a means to identify graphics objects with a user-specified label. The default is an empty string.

# Hgtransform Properties

---

Use the `Tag` property and the `findobj` function to manipulate specific objects within a plotting hierarchy.

For example, create an `hgtransform` object and set the `Tag` property:

```
t = hgtransform('Tag','subgroup1')
```

When you want to access the `hgtransform` object to add another object, use `findobj` to find the `hgtransform` object's handle. The following statement adds a line to `subgroup1` (assuming `x` and `y` are defined).

```
line('XData',x,'YData',y,...
 'Parent',findobj('Tag','subgroup1'))
```

## Type

string (read-only)

*Type of graphics object.* String that identifies the class of the graphics object. Use this property to find all objects of a given type within a plotting hierarchy. For `hgtransform` objects, `Type` is `'hgtransform'`. The following statement finds all the `hgtransform` objects in the current axes.

```
t = findobj(gca,'Type','hgtransform');
```

## UIContextMenu

handle of `uicontextmenu` object

*Associate a context menu with the hgtransform object.* Assign this property the handle of a `uicontextmenu` object created in the `hgtransform` object's figure. Use the `uicontextmenu` function to create the context menu. MATLAB displays the context menu whenever you right-click over the extent of the `hgtransform` object.

## UserData

array

*User-specified data.* Data you want to associate with the hgtransform object (including cell arrays and structures). The default value is an empty array. MATLAB does not use this data, but you can access it using the `set` and `get` commands.

**Visible**

{on} | off

*Visibility of hgtransform object and its children.* By default, hgtransform object visibility is on. This means all children of the hgtransform are visible unless the child object's `Visible` property is off. Setting an hgtransform object's `Visible` property to off also makes its children invisible.

## See Also

hgtransform

# hidden

---

**Purpose** Remove hidden lines from mesh plot

**Syntax** `hidden on`  
`hidden off`  
`hidden`

**Description** Hidden line removal draws only those lines that are not obscured by other objects in a 3-D view. The `hidden` function only applies to surface plot objects that have a uniform `FaceColor`.

`hidden on` turns on hidden line removal for the current mesh plot so lines in the back of a mesh are hidden by those in front. This is the default behavior.

`hidden off` turns off hidden line removal for the current mesh plot.

`hidden` toggles the hidden line removal state.

**Algorithms** When a surface graphics object has a uniform `FaceColor` matching the `Color` property of the axes, `hidden off` sets the `FaceColor` of the surface object to 'none'.

`hidden on` sets the `FaceColor` property of such surface objects to match the axes `Color` property (or to match that of the figure, if axes `Color` is 'none').

**Examples** **Show Obscured Lines**

Create a mesh plot of the `peaks` function.

```
figure
mesh(peaks)
```

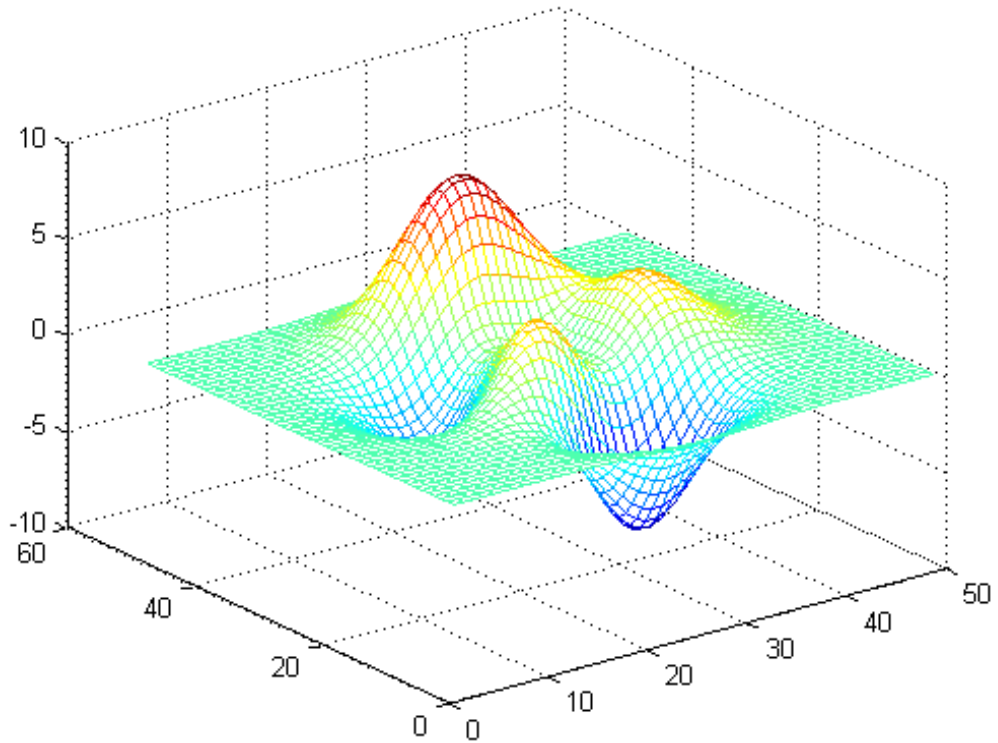

By default, MATLAB® hides obscured lines from the view. Show the obscured parts of the mesh by setting the hidden line removal to off.

```
hidden off
```

# hidden

---

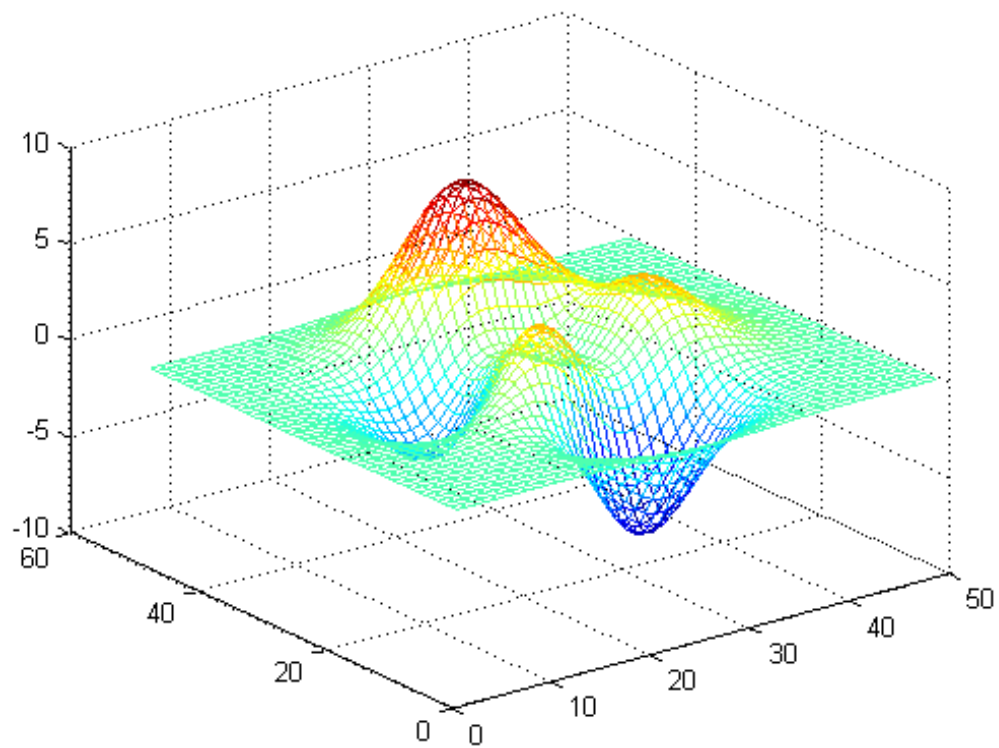

## See Also

[shading](#) | [mesh](#) | [EdgeColor](#) | [FaceColor](#)



---

|                    |                                                                                                                                                 |
|--------------------|-------------------------------------------------------------------------------------------------------------------------------------------------|
| <b>Purpose</b>     | Hilbert matrix                                                                                                                                  |
| <b>Syntax</b>      | <code>H = hilb(n)</code>                                                                                                                        |
| <b>Description</b> | <code>H = hilb(n)</code> returns the Hilbert matrix of order <code>n</code> .                                                                   |
| <b>Definitions</b> | The Hilbert matrix is a notable example of a poorly conditioned matrix [1]. The elements of the Hilbert matrices are $H(i,j) = 1/(i + j - 1)$ . |
| <b>Examples</b>    | Even the fourth-order Hilbert matrix shows signs of poor conditioning.<br><br><code>cond(hilb(4)) =</code><br><code>1.5514e+04</code>           |
| <b>References</b>  | [1] Forsythe, G. E. and C. B. Moler, <i>Computer Solution of Linear Algebraic Systems</i> , Prentice-Hall, 1967, Chapter 19.                    |
| <b>See Also</b>    | <code>invhilb</code>                                                                                                                            |

# hist

---

**Purpose** Histogram plot

**Syntax**

```
hist(data)
hist(data,nbins)
hist(data,xvalues)

hist(axes_handle, __)

nelements = hist(__)
[nelements,centers] = hist(__)
```

**Description** `hist(data)` creates a histogram bar plot of `data`. Elements in `data` are sorted into 10 equally spaced bins along the *x*-axis between the minimum and maximum values of `data`. Bins are displayed as rectangles such that the height of each rectangle indicates the number of elements in the bin.

`hist(data,nbins)` sorts `data` into the number of bins specified by the scalar `nbins`.

`hist(data,xvalues)` sorts `data` into bins with intervals determined by the vector `xvalues`.

- If `xvalues` is a vector of evenly spaced values, then `hist` uses the values as the bin centers.
- If `xvalues` is a vector unevenly spaced values, then `hist` uses the midpoints between consecutive values as the bin edges.

The length of the vector, `length(xvalues)`, determines the number of bins.

`hist(axes_handle, __ )` plots into the axes specified by `axes_handle` instead of into the current axes (`gca`). The option `axes_handle` can precede any of the input argument combinations in the previous syntaxes.

`nelements = hist( ___ )` returns a row vector, `nelements`, indicating the number of elements in each bin.

`[nelements,centers] = hist( ___ )` returns an additional row vector, `centers`, indicating the location of each bin center on the *x*-axis. To plot the histogram, you can use `bar(centers,nelements)`.

## Input Arguments

### **data - Data to distribute among bins**

vector or matrix

Data to distribute among bins, specified as a vector or a matrix.

- If `data` is a vector, then one histogram is created.
- If `data` is a matrix, then a histogram is created separately for each column. Each histogram plot is displayed on the same figure with a different color.

If `data` contains NaN values, then `hist` ignores these values and does not include them in the bin counts.

If `data` contains the infinite values `-inf` or `inf`, then `hist` sorts `-inf` into the first bin and `inf` into the last bin. If you do not specify the bin intervals, then `hist` calculates the bin intervals using only the finite values in `data`.

### **Data Types**

single | double | int8 | int16 | int32 | int64 | uint8 |  
uint16 | uint32 | uint64 | logical

### **nbins - Number of bins**

10 (default) | scalar

Number of bins, specified as a scalar.

### **Data Types**

single | double | int8 | int16 | int32 | int64 | uint8 |  
uint16 | uint32 | uint64 | logical

# hist

---

## **xvalues - Values to calculate bin intervals**

vector

Values to calculate bin intervals, specified as a vector.

- If the values in `xvalues` are equally spaced, then these values are the bin centers.
- If the values in `xvalues` are not equally spaced, then these values are indicated by markers along the  $x$ -axis, but are not the actual bin centers. Instead, MATLAB calculates the bin edges as the midpoints between consecutive values in vector `xvalues`. To specify directly the bin edges use `histc`.

The first and last bins extend to cover the minimum and maximum values in `data`.

Use only finite values with `xvalues`. If `xvalues` contains `-inf` or `inf`, then `hist` does not populate the bins.

## **Data Types**

`single` | `double` | `int8` | `int16` | `int32` | `int64` | `uint8` | `uint16` | `uint32` | `uint64` | `logical`

## **axes\_handle - Axes handle**

handle

Axes handle, which is the reference to an axes object. Use the `gca` function to get the handle to the current axes, for example, `axes_handle = gca;`

## **Output Arguments**

### **nelements - Number of elements in each bin**

row vector

Number of elements in each bin, returned as a row vector.

### **centers - Bin centers**

row vector

Bin centers, returned as a row vector. If used with the syntax `[nelements,centers] = hist(data,xvalues)`, then the output centers is equal to the input xvalues.

## Examples

### Create Histogram Bar Plot with Vector Input

```
figure
data = [0,2,9,2,5,8,7,3,1,9,4,3,5,8,10,0,1,2,9,5,10];
hist(data)
```

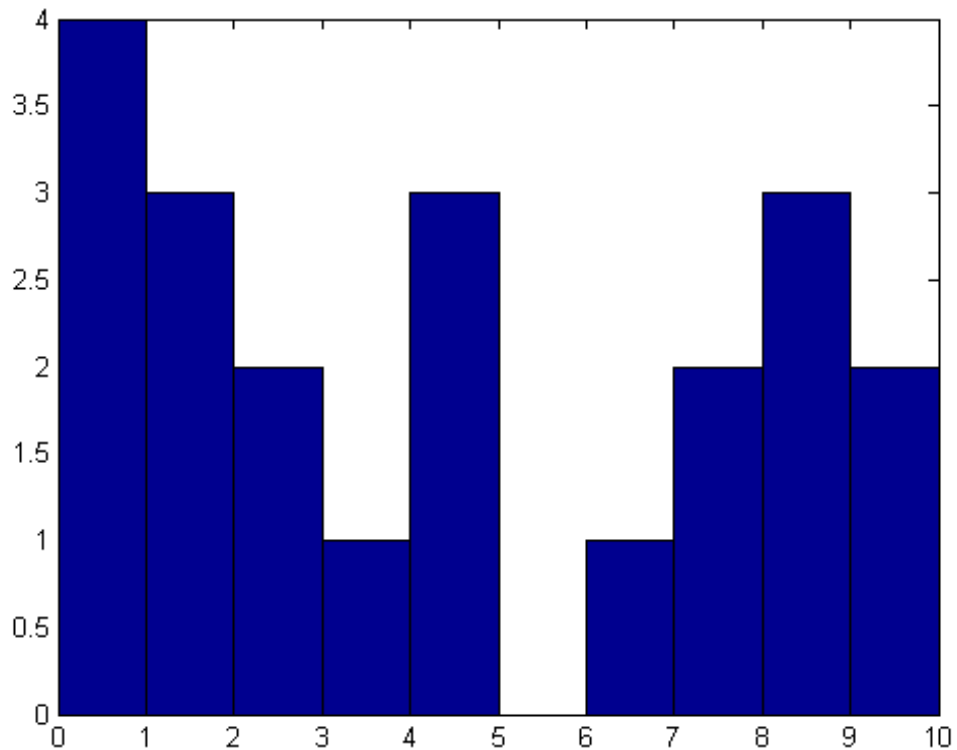

# hist

---

`hist` sorts the values in `data` among 10 equally spaced bins between 0 and 10, the minimum and maximum values.

## **Create Histogram Bar Plot with Matrix Input**

Initialize the random-number generator to make the output of `randn` repeatable. Generate 1,000 normally distributed pseudorandom numbers and create a histogram bar plot.

```
rng(0, 'twister')
data = randn(1000,3);
figure
hist(data)
```

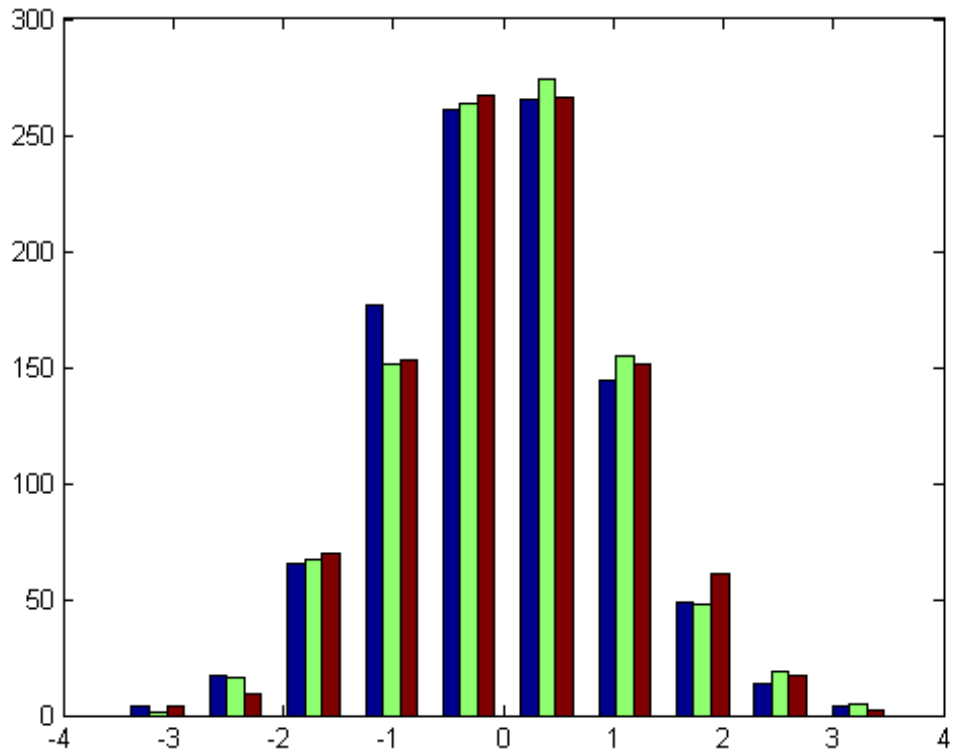

The values in `data` are sorted among 10 equally spaced bins between the minimum and maximum values. `hist` sorts the columns of `data` separately and plots each column with a different color.

### Specify Number of Bins

Initialize the random-number generator to make the output of `randn` repeatable. Generate 1,000 normally distributed pseudorandom numbers.

# hist

---

```
rng(0,'twister')
data = randn(1000,1);
```

Create a histogram plot of data sorted into 50 equally spaced bins.

```
figure
nbins = 50;
hist(data,nbins)
```

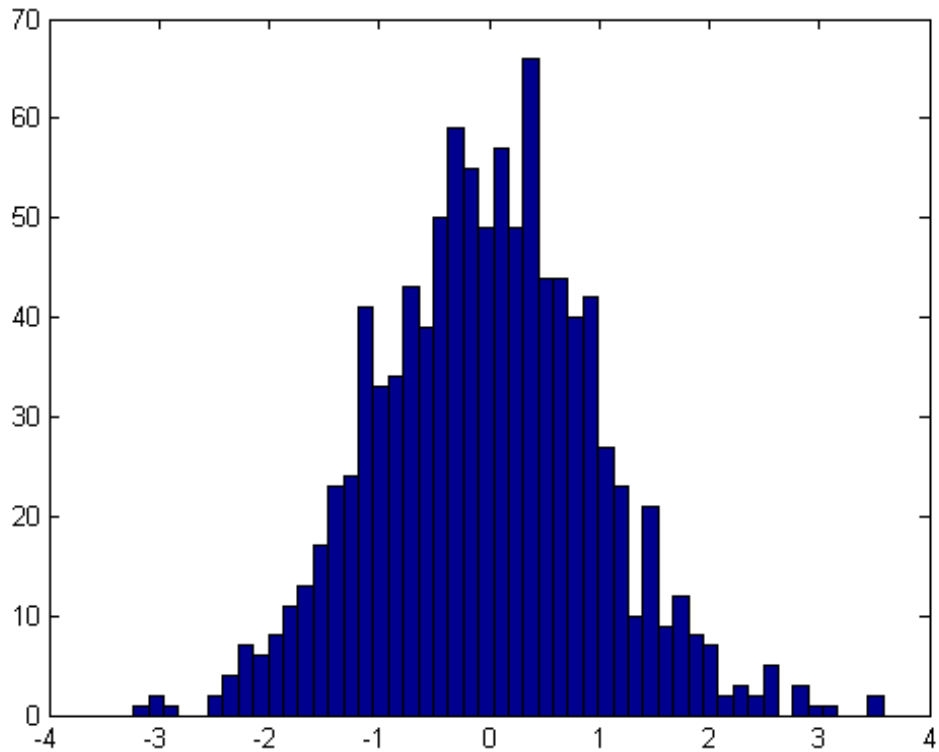



### Specify Bin Intervals

Create a figure divided into three subplots. Plot a histogram of the same data set in all three subplots using different bin intervals for each histogram.

First, initialize the random-number generator to make the output of `randn` repeatable. Generate 1,000 normally distributed pseudorandom numbers.

```
rng(0, 'twister')
data = randn(1000,1);
```

In the upper subplot specify the bin centers using a vector of evenly spaced values that span the values in `data`.

```
figure
subplot(3,1,1)
xvalues1 = -4:4;
hist(data,xvalues1)
```

# hist

---

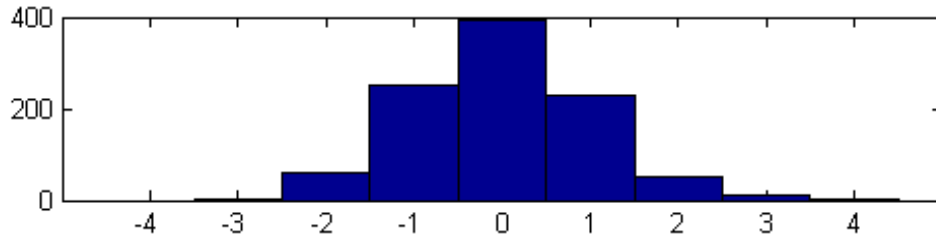

In the middle subplot specify the bin centers using a vector of evenly spaced values that do not span the values in `data`. Notice that the first and last bins extend to cover the minimum and maximum values in `data`.

```
subplot(3,1,2)
xvalues2 = -2:2;
hist(data,xvalues2)
```

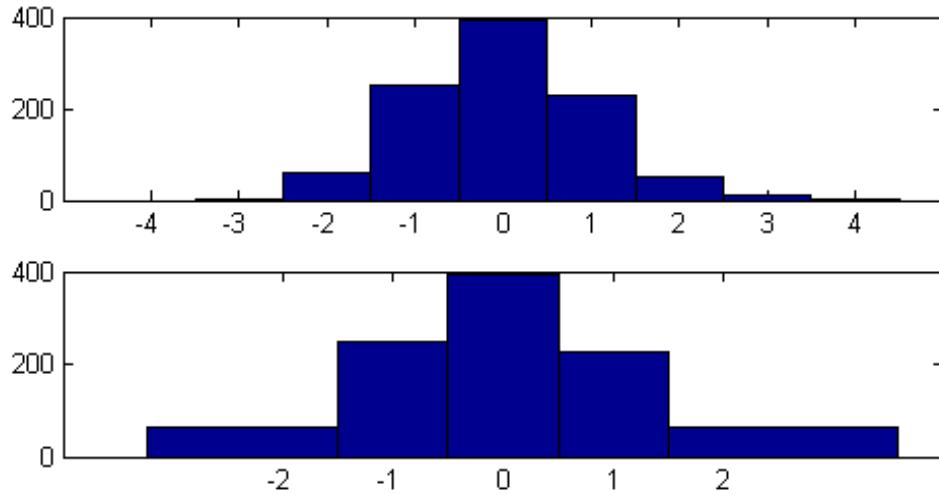

In the lower subplot set the bin intervals using a vector of unevenly spaced values. These unevenly spaced values are not used as the bin centers. MATLAB® indicates the specified values by markers along the  $x$ -axis.

```
subplot(3,1,3)
xvalues3 = [-4,-2.5,0,0.5,1,3];
hist(data,xvalues3)
```

# hist

---

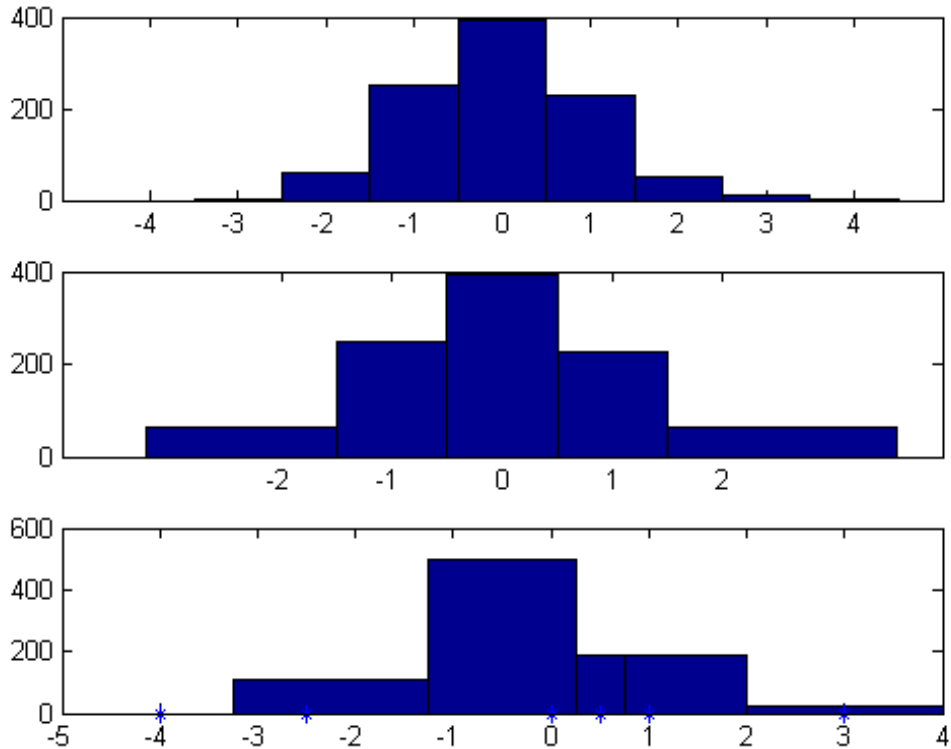

## Specify Axes for Histogram Bar Plot

Initialize the random-number generator to make the output of `randn` repeatable. Generate 1,000 normally distributed pseudorandom numbers.

```
rng(0,'twister')
data = randn(1000,1);
```

Create a figure with handles to two subplots. In the upper subplot, plot a histogram of `data` sorted into 50 equally spaced bins. In the lower subplot, plot a histogram of the same data and use bins with centers at -3, 0, and 3.

```
figure
s(1) = subplot(2,1,1);
s(2) = subplot(2,1,2);

hist(s(1),data,50)

xvalues = [-3,0,3];
hist(s(2),data,xvalues)
```

# hist

---

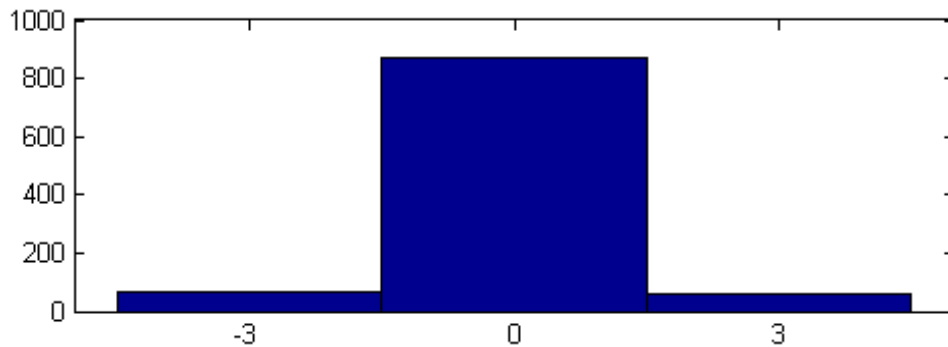
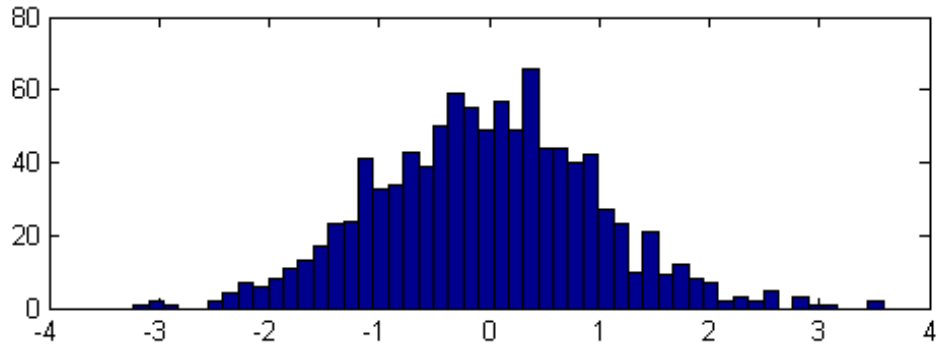

## Plot Histogram Using Bar Graph

Initialize the random-number generator to make the output of `randn` repeatable. Generate 1,000 normally distributed pseudorandom numbers.

```
rng(0,'twister')
data = randn(1000,1);
```

Sort data into 10 equally spaced bins. Get the number of elements in each bin and the locations of the bin centers.

```
[nelements,centers] = hist(data)
```

```
nelements =
```

```
 4 27 88 190 270 243 123 38 13 4
```

```
centers =
```

```
Columns 1 through 7
```

```
 -2.8915 -2.2105 -1.5294 -0.8484 -0.1673 0.5137 1.1947
```

```
Columns 8 through 10
```

```
 1.8758 2.5568 3.2379
```

Use `bar` to plot the histogram.

```
figure
bar(centers,nelements)
```

# hist

---

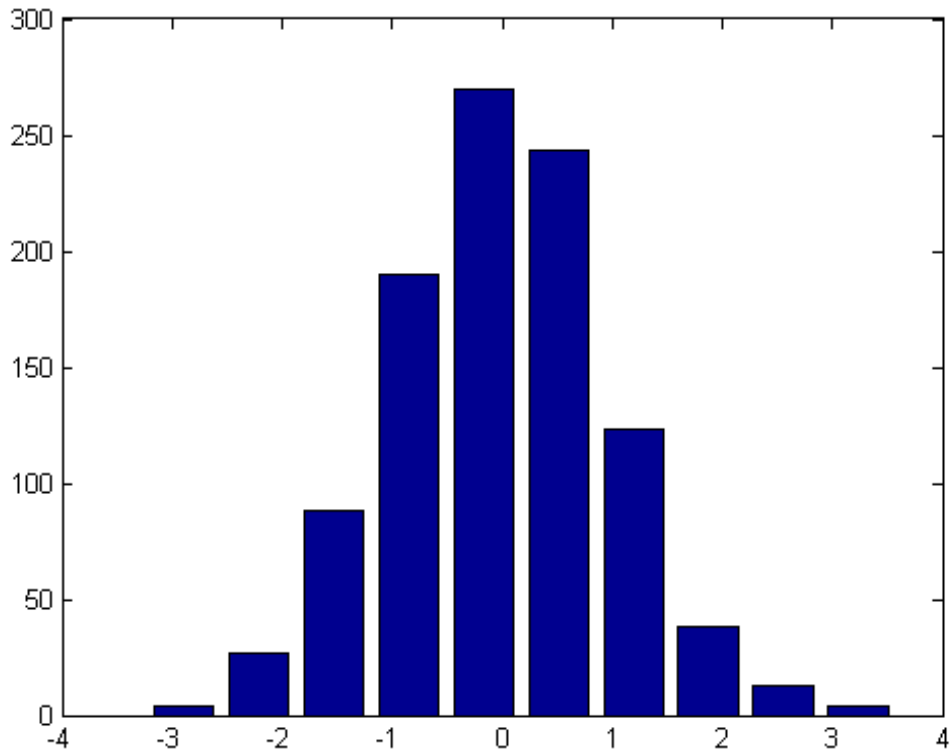

## Change Histogram Color Properties

Initialize the random-number generator to make the output of `randn` repeatable. Generate 1,000 normally distributed pseudorandom numbers and create a histogram bar plot.

```
figure
rng(0,'twister')
data = randn(1000,1);
hist(data)
```



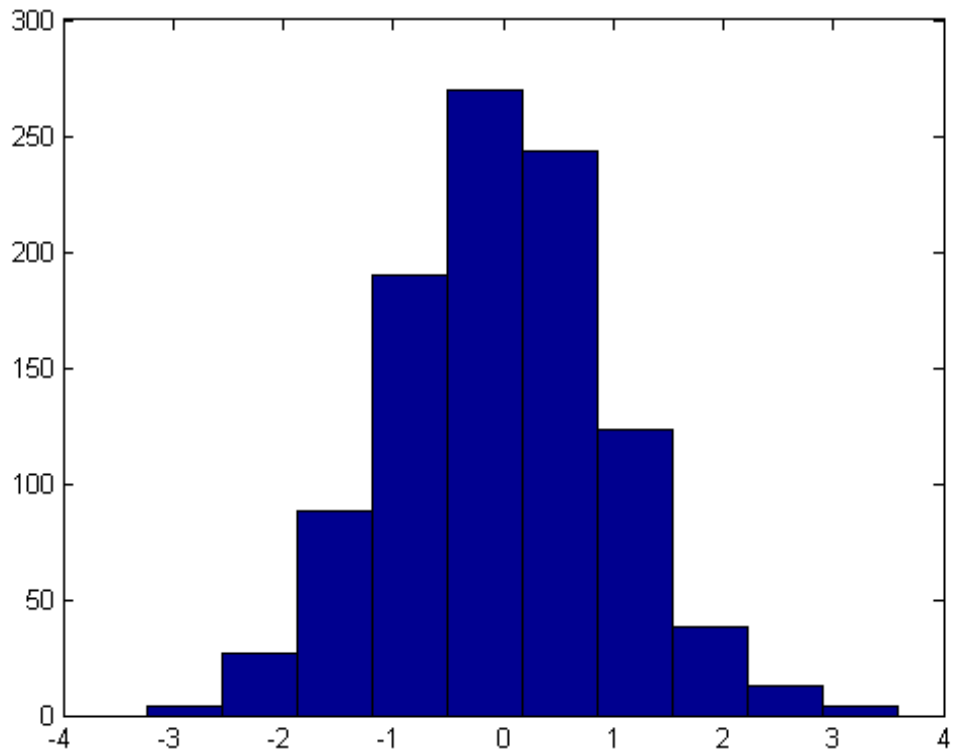

Get the handle to the patch object that creates the histogram bar plot.

```
h = findobj(gca,'Type','patch');
```

Use the handle to change the face color and the edge color of the bars plotted.

```
set(h,'FaceColor',[0 .5 .5],'EdgeColor','w')
```

# hist

---

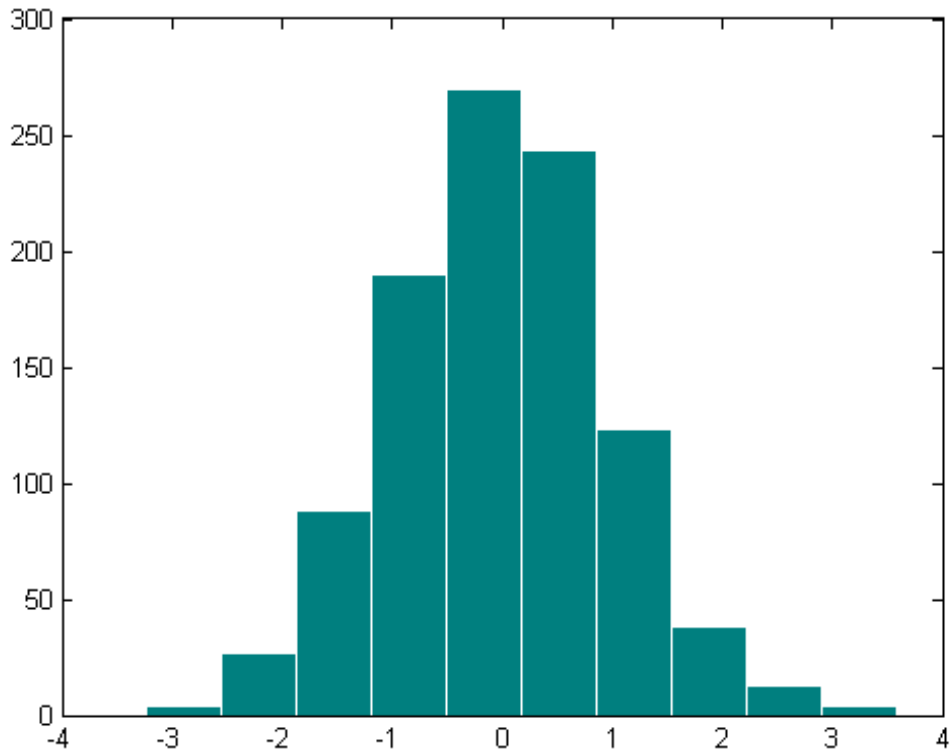

## Tips

The *x*-axis reflects the range of values in `data`. The *y*-axis ranges from 0 to the greatest number of elements deposited in any bin.

## See Also

`bar` | `ColorSpec` | `histc` | `mode` | `patch` | `rose` | `stairs`

**Purpose**

Histogram bin count

**Syntax**

```
bincounts = histc(x,binranges)
bincounts = histc(x,binranges,dim)
[bincounts,ind]= histc(__)
```

**Description**

`bincounts = histc(x,binranges)` counts the number of values in `x` that are within each specified bin range. The input, `binranges`, determines the endpoints for each bin. The output, `bincounts`, contains the number of elements from `x` in each bin.

- If `x` is a vector, then `histc` returns `bincounts` as a vector of histogram bin counts.
- If `x` is a matrix, then `histc` operates along each column of `x` and returns `bincounts` as a matrix of histogram bin counts for each column.

To plot the histogram, use `bar(binranges,bincounts,'histc')`.

`bincounts = histc(x,binranges,dim)` operates along the dimension `dim`.

`[bincounts,ind]= histc( __ )` returns `ind`, an array the same size as `x` indicating the bin number that each entry in `x` sorts into. Use this syntax with any of the previous input argument combinations.

**Input Arguments****x - Values to be sorted**

vector | matrix

Values to be sorted, specified as a vector or a matrix. The bin counts do not include values in `x` that are NaN or that lie outside the specified bin ranges. If `x` contains complex values, then `histc` ignores the imaginary parts and uses only the real parts.

**Data Types**

single | double | int8 | int16 | int32 | int64 | uint8 |  
uint16 | uint32 | uint64 | logical

## **binranges - Bin ranges**

vector | matrix

Bin ranges, specified as a vector of monotonically nondecreasing values or a matrix of monotonically nondecreasing values running down each successive column. The values in `binranges` determine the left and right endpoints for each bin. If `binranges` contains complex values, then `histc` ignores the imaginary parts and uses only the real parts.

If `binranges` is a matrix, then `histc` determines the bin ranges by using values running down successive columns. Each bin includes the left endpoint, but does not include the right endpoint. The last bin consists of the scalar value equal to last value in `binranges`.

For example, if `binranges` equals the vector `[0,5,10,13]`, then `histc` creates four bins. The first bin includes values greater than or equal to 0 and strictly less than 5. The second bin includes values greater than or equal to 5 and less than 10, and so on. The last bin contains the scalar value 13.

### **Data Types**

single | double | int8 | int16 | int32 | int64 | uint8 |  
uint16 | uint32 | uint64 | logical

## **dim - Dimension along which to operate**

scalar

Dimension along which to operate, specified as a scalar.

### **Data Types**

single | double | int8 | int16 | int32 | int64 | uint8 |  
uint16 | uint32 | uint64 | logical

## **Output Arguments**

## **bincounts - Number of elements in each bin**

vector | matrix

Number of elements in each bin, returned as a vector or a matrix that is the same size as `x`. The last entry in `bincounts` is the number of values in `x` that equal the last entry in `binranges`.

**ind - Bin index numbers**

vector | matrix

Bin index numbers, returned as a vector or a matrix that is the same size as `x`.

**Examples****Create Histogram Plot**

Initialize the random number generator to make the output of `randn` repeatable.

```
rng(0,'twister')
```

Define `x` as 100 normally distributed random numbers. Define bin ranges between -4 and 4. Determine the number of values in `x` that are within each specified bin range. Return the number of elements in each bin in `bincounts`.

```
x = randn(100,1);
binranges = -4:4;
[bincounts] = histc(x,binranges)
```

```
bincounts =
```

```
0
2
17
28
32
16
3
2
0
```

To plot the histogram, use the `bar` function.

# histc

---

```
figure
bar(binranges,bincounts,'histc')
```

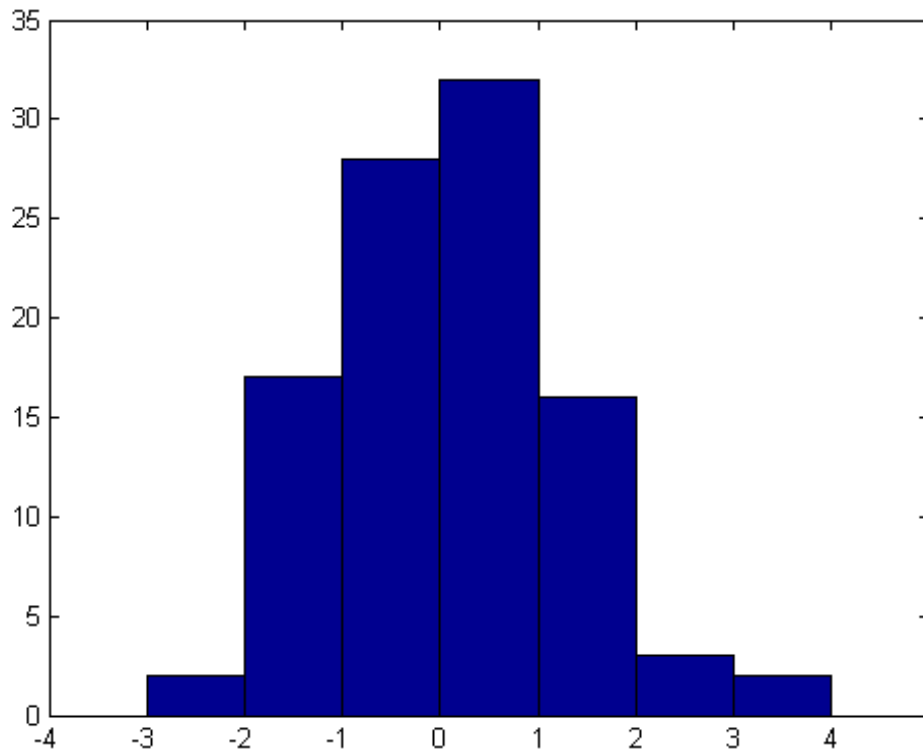

## Return Bin Numbers for Histogram

Defined ages as a vector of ages. Sort ages into bins with varying ranges between 0 and 75.

```
ages = [3,12,24,15,5,74,23,54,31,23,64,75];
binranges = [0,10,25,50,75];
```

```
[bincounts,ind] = histc(ages,binranges)
```

```
bincounts =
```

```
 2 5 1 3 1
```

```
ind =
```

```
 1 2 2 2 1 4 2 4 3 2 4
```

`bincounts` contains the number of values in each bin. `ind` indicates the bin numbers.

### Tips

- If values in `x` lie outside the specified bin ranges, then `histc` does not include these values in the bin counts. Start and end the `binranges` vector with `-inf` and `inf` to ensure that all values in `x` are included in the bin counts.

### See Also

`bar` | `hist` | `mode`

# hold

---

**Purpose** Retain current graph when adding new graphs

**Syntax** `hold on`  
`hold off`  
`hold all`  
`hold`  
`hold(axes_handle,...)`

**Description** The `hold` function controls whether MATLAB clears the current graph when you make subsequent calls to plotting functions (the default), or adds a new graph to the current graph.

`hold on` retains the current graph and adds another graph to it. MATLAB adjusts the axes limits, tick marks, and tick labels as necessary to display the full range of the added graph.

`hold off` resets hold state to the default behavior, in which MATLAB clears the existing graph and resets axes properties to their defaults before drawing new plots.

`hold all` holds the graph and the current line color and line style so that subsequent plotting commands do not reset the `ColorOrder` and `LineStyleOrder` property values to the beginning of the list. Plotting commands continue cycling through the predefined colors and line styles from where the last graph stopped in the list.

`hold` reverses the current hold state. If the hold state is currently on, then a `hold` command sets the state to off. Similarly, if the hold state is currently off, then a `hold` command sets the state to on.

`hold(axes_handle,...)` applies the hold to the axes identified by the handle `axes_handle`. If several axes objects exist in a figure window, each axes has its own hold state. `hold` also creates an axes if one does not exist.

Test the hold state using the `ishold` function.



**Examples****Add Plot to Existing Graph**

Plot the sine function. Then, set the hold state to on to retain the current graph. Add a cosine plot.

```
x = -pi:pi/20:pi;
y1 = sin(x);
y2 = cos(x);

plot(x,y1);
hold on
plot(x,y2);
hold off % reset hold state
```

# hold

---

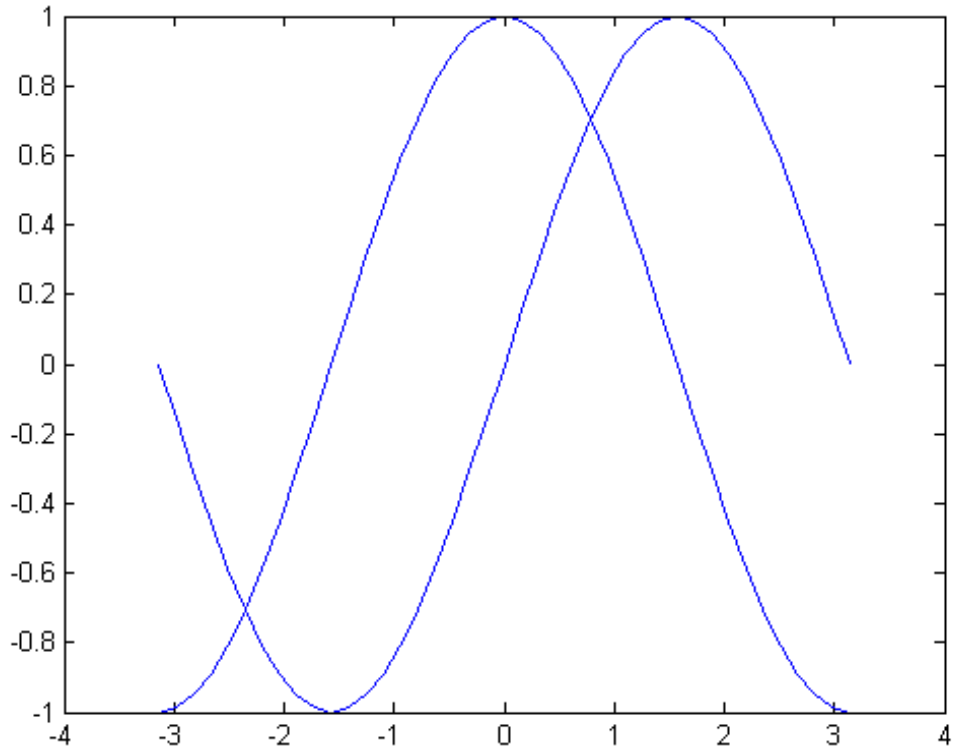

## Algorithm

`hold` toggles the `NextPlot` axes property between the `add` and `replace`.

`hold on` sets the `NextPlot` property of the current figure and axes to `add`. `hold off` sets the `NextPlot` property of the current axes to `replace`.

## Tips

If the range of subsequently added data is much greater than the original data, the original graph can become difficult to see in one

axes. In these cases, it is usually better to use two separate axes. See `subplot` to create multiple axes in one figure.

**See Also**

`axis` | `cla` | `ishold` | `newplot`

**How To**

- `NextPlot`
- “Controlling Graphics Output”

# home

---

**Purpose** Send cursor home

**Syntax** home

**Description** home moves the cursor to the upper-left corner of the window. When using the MATLAB desktop, home also scrolls the visible text in the window up and out of view. You can use the scroll bar to see what was previously on the screen.

**Examples** Execute a MATLAB command that displays something in the Command Window and then run the home function. home moves the cursor to the upper-left corner of the screen and clears the screen.

```
magic(5)
```

```
ans =
```

```
 17 24 1 8 15
 23 5 7 14 16
 4 6 13 20 22
 10 12 19 21 3
 11 18 25 2 9
```

```
home
```

**See Also** clc

|                    |                                                                                                                                                                                                                                                                                                                                                                                                                                                                                                                                                                                                                                                                                                                                                                                                                                                                                                                                                                                                                                                                                        |
|--------------------|----------------------------------------------------------------------------------------------------------------------------------------------------------------------------------------------------------------------------------------------------------------------------------------------------------------------------------------------------------------------------------------------------------------------------------------------------------------------------------------------------------------------------------------------------------------------------------------------------------------------------------------------------------------------------------------------------------------------------------------------------------------------------------------------------------------------------------------------------------------------------------------------------------------------------------------------------------------------------------------------------------------------------------------------------------------------------------------|
| <b>Purpose</b>     | Concatenate arrays horizontally                                                                                                                                                                                                                                                                                                                                                                                                                                                                                                                                                                                                                                                                                                                                                                                                                                                                                                                                                                                                                                                        |
| <b>Syntax</b>      | <code>C = horzcat(A1,...,AN)</code>                                                                                                                                                                                                                                                                                                                                                                                                                                                                                                                                                                                                                                                                                                                                                                                                                                                                                                                                                                                                                                                    |
| <b>Description</b> | <p><code>C = horzcat(A1,...,AN)</code> horizontally concatenates arrays <code>A1,...,AN</code>. All arrays in the argument list must have the same number of rows.</p> <ul style="list-style-type: none"><li>• If the inputs are multidimensional arrays, <code>horzcat</code> concatenates along the second dimension. The first and remaining dimensions must match.</li><li>• If the inputs are tables, <code>horzcat</code> concatenates by matching row names when present, or by matching position for tables that do not have row names. All the table inputs must have unique variable names and the row names for all tables that have them must be identical, except for order.</li></ul> <p><code>horzcat</code> assigns values for the <code>Description</code> and <code>UserData</code> properties in <code>C</code> using the first nonempty value for the corresponding property in the tables <code>A1,...,AN</code>.</p> <p>MATLAB calls <code>C = horzcat(A1, A2, ...)</code> for the syntax <code>C = [A1 A2 ...]</code> when any of the inputs are an object.</p> |
| <b>Tips</b>        | <p>You can concatenate categorical arrays with cell arrays of strings. For more information, see “Combine Categorical Arrays”.</p> <p>If all the input arrays are ordinal categorical arrays, they must have the same sets of categories including their order. For more information, see “Ordinal Categorical Arrays”.</p> <p>For information on combining unlike integer types, integers with nonintegers, cell arrays with non-cell arrays, or empty matrices with other elements, see “Valid Combinations of Unlike Classes”.</p>                                                                                                                                                                                                                                                                                                                                                                                                                                                                                                                                                  |
| <b>Examples</b>    | <p><b>Horizontally Concatenate Two Matrices</b></p> <p>Create a 3-by-5 matrix, <code>A</code>.</p> <pre>A = magic(5);</pre>                                                                                                                                                                                                                                                                                                                                                                                                                                                                                                                                                                                                                                                                                                                                                                                                                                                                                                                                                            |

# horzcat

---

```
A(4:5,:) = []
```

```
A =
```

```
 17 24 1 8 15
 23 5 7 14 16
 4 6 13 20 22
```

Create a 3-by-3 matrix, B.

```
B = magic(3)*100
```

```
B =
```

```
 800 100 600
 300 500 700
 400 900 200
```

Horizontally concatenate A and B.

```
C = horzcat(A,B)
```

```
C =
```

```
 17 24 1 8 15 800 100 600
 23 5 7 14 16 300 500 700
 4 6 13 20 22 400 900 200
```

## Horizontally Concatenate Two Tables

Create a table, A, with three rows and two variables.

```
A = table([5;6;5],['M'; 'M'; 'M'],...
 'VariableNames',{'Age' 'Gender'},...
 'RowNames',{'Thomas' 'Gordon' 'Percy'})
```

```
A =
```

```
 Age Gender
```

```

 --- -----
Thomas 5 M
Gordon 6 M
Percy 5 M

```

Create a table, B, with three rows and three variables.

```

B = table([45;41;40],[45;32;34],{'NY';'CA';'MA'},...
 'VariableNames',{'Height' 'Weight' 'Birthplace'},...
 'RowNames',{'Percy' 'Gordon' 'Thomas'})

```

B =

```

 Height Weight Birthplace
 ----- -
Percy 45 45 'NY'
Gordon 41 32 'CA'
Thomas 40 34 'MA'

```

Horizontally concatenate A and B.

```
C = horzcat(A,B)
```

C =

```

 Age Gender Height Weight Birthplace
 --- -
Thomas 5 M 40 34 'MA'
Gordon 6 M 41 32 'CA'
Percy 5 M 45 45 'NY'

```

The order of rows in C matches the order in A.

## See Also

vertcat | cat | strcat | char | special character

## How To

- “Redefining Concatenation for Your Class”

# horzcat (tscollection)

---

**Purpose** Horizontal concatenation for `tscollection` objects

**Syntax** `tsc = horzcat(tsc1,tsc2,...)`

**Description** `tsc = horzcat(tsc1,tsc2,...)` performs horizontal concatenation for `tscollection` objects:

```
tsc = [tsc1 tsc2 ...]
```

This operation combines multiple `tscollection` objects, which must have the same time vectors, into one `tscollection` containing `timeseries` objects from all concatenated collections.

**See Also** `tscollection | vertcat (tscollection)`



---

|                    |                                                                                                                                                                                                                                                                                                                                                                                                                                                                                                                                                                                                                                                                                                                                                                                                                                                         |
|--------------------|---------------------------------------------------------------------------------------------------------------------------------------------------------------------------------------------------------------------------------------------------------------------------------------------------------------------------------------------------------------------------------------------------------------------------------------------------------------------------------------------------------------------------------------------------------------------------------------------------------------------------------------------------------------------------------------------------------------------------------------------------------------------------------------------------------------------------------------------------------|
| <b>Purpose</b>     | Convert HSV colormap to RGB colormap                                                                                                                                                                                                                                                                                                                                                                                                                                                                                                                                                                                                                                                                                                                                                                                                                    |
| <b>Syntax</b>      | <pre>M = hsv2rgb(H) rgb_image = hsv2rgb(hsv_image)</pre>                                                                                                                                                                                                                                                                                                                                                                                                                                                                                                                                                                                                                                                                                                                                                                                                |
| <b>Description</b> | <p><code>M = hsv2rgb(H)</code> converts a hue-saturation-value (HSV) colormap to a red-green-blue (RGB) colormap. <code>H</code> is an <math>m</math>-by-3 matrix, where <math>m</math> is the number of colors in the colormap. The columns of <code>H</code> represent hue, saturation, and value, respectively. <code>M</code> is an <math>m</math>-by-3 matrix. Its columns are intensities of red, green, and blue, respectively.</p> <p><code>rgb_image = hsv2rgb(hsv_image)</code> converts the HSV image to the equivalent RGB image. HSV is an <math>m</math>-by-<math>n</math>-by-3 image array whose three planes contain the hue, saturation, and value components for the image. RGB is returned as an <math>m</math>-by-<math>n</math>-by-3 image array whose three planes contain the red, green, and blue components for the image.</p> |
| <b>Tips</b>        | <p>As <code>H(:,1)</code> varies from 0 to 1, the resulting color varies from red through yellow, green, cyan, blue, and magenta, and returns to red. When <code>H(:,2)</code> is 0, the colors are unsaturated (i.e., shades of gray). When <code>H(:,2)</code> is 1, the colors are fully saturated (i.e., they contain no white component). As <code>H(:,3)</code> varies from 0 to 1, the brightness increases.</p> <p>The MATLAB hsv colormap uses <code>hsv2rgb([huesaturationvalue])</code> where hue is a linear ramp from 0 to 1, and saturation and value are all 1's.</p>                                                                                                                                                                                                                                                                    |
| <b>See Also</b>    | <code>brighten</code>   <code>colormap</code>   <code>rgb2hsv</code>                                                                                                                                                                                                                                                                                                                                                                                                                                                                                                                                                                                                                                                                                                                                                                                    |

# hypot

---

**Purpose** Square root of sum of squares

**Syntax** `c = hypot(a,b)`

**Description** `c = hypot(a,b)` returns the element-wise result of the following equation, computed to avoid underflow and overflow:

$$c = \text{sqrt}(\text{abs}(a).^2 + \text{abs}(b).^2)$$

Inputs `a` and `b` must follow these rules:

- Both `a` and `b` must be single- or double-precision, floating-point arrays.
- The sizes of the `a` and `b` arrays must either be equal, or one a scalar and the other nonscalar. In the latter case, `hypot` expands the scalar input to match the size of the nonscalar input.
- If `a` or `b` is an empty array (0-by-N or N-by-0), the other must be the same size or a scalar. The result `c` is an empty array having the same size as the empty input(s).

`hypot` returns the following in output `c`, depending upon the types of inputs:

- If the inputs to `hypot` are complex (`w+xi` and `y+zi`), then the statement `c = hypot(w+xi,y+zi)` returns the *positive real* result
$$c = \text{sqrt}(\text{abs}(w).^2 + \text{abs}(x).^2 + \text{abs}(y).^2 + \text{abs}(z).^2)$$
- If `a` or `b` is `-Inf`, `hypot` returns `Inf`.
- If neither `a` nor `b` is `Inf`, but one or both inputs is `NaN`, `hypot` returns `NaN`.
- If all inputs are finite, the result is finite. The one exception is when both inputs are very near the value of the MATLAB constant `realmax`. The reason for this is that the equation `c = hypot(realmax,realmax)` is theoretically `sqrt(2)*realmax`, which overflows to `Inf`.

## Examples

### Example 1

To illustrate the difference between using the `hypot` function and coding the basic hypot equation in M-code, create an anonymous function that performs the same function as `hypot`, but without the consideration to underflow and overflow that `hypot` offers:

```
myhypot = @(a,b) sqrt(abs(a).^2+abs(b).^2);
```

Find the upper limit at which your coded function returns a useful value. You can see that this test function reaches its maximum at about  $1e154$ , returning an infinite result at that point:

```
myhypot(1e153,1e153)
ans =
 1.4142e+153
```

```
myhypot(1e154,1e154)
ans =
 Inf
```

Do the same using the `hypot` function, and observe that `hypot` operates on values up to about  $1e308$ , which is approximately equal to the value for `realmax` on your computer (the largest double-precision floating-point number you can represent on a particular computer):

```
hypot(1e308,1e308)
ans =
 1.4142e+308
```

```
hypot(1e309,1e309)
ans =
 Inf
```

### Example 2

`hypot(a,a)` theoretically returns  $\sqrt{2} * \text{abs}(a)$ , as shown in this example:

```
x = 1.271161e308;
```

# hypot

---

```
y = x * sqrt(2)
y =
 1.7977e+308
```

```
y = hypot(x,x)
y =
 1.7977e+308
```

## See Also

[sqrt](#) | [abs](#) | [norm](#)

---

|                        |                                                                                                                                                                                                                                                                                                                                                                                                                                                                                                                                                                                                                                                                       |
|------------------------|-----------------------------------------------------------------------------------------------------------------------------------------------------------------------------------------------------------------------------------------------------------------------------------------------------------------------------------------------------------------------------------------------------------------------------------------------------------------------------------------------------------------------------------------------------------------------------------------------------------------------------------------------------------------------|
| <b>Purpose</b>         | Imaginary unit                                                                                                                                                                                                                                                                                                                                                                                                                                                                                                                                                                                                                                                        |
| <b>Syntax</b>          | <pre>1i z = a + bi z = x + 1i*y</pre>                                                                                                                                                                                                                                                                                                                                                                                                                                                                                                                                                                                                                                 |
| <b>Description</b>     | <p>1i returns the basic imaginary unit. i is equivalent to <code>sqrt(-1)</code>.</p> <p>You can use i to enter complex numbers. You also can use the character j as the imaginary unit. To create a complex number without using i and j, use the <code>complex</code> function.</p> <p><code>z = a + bi</code> returns a complex numerical constant, z.</p> <p><code>z = x + 1i*y</code> returns a complex array, z.</p>                                                                                                                                                                                                                                            |
| <b>Input Arguments</b> | <p><b>a - Real component of complex scalar</b><br/>scalar<br/>Real component of a complex scalar, specified as a scalar.</p> <p><b>Data Types</b><br/>single   double</p> <p><b>b - Imaginary component of complex scalar</b><br/>scalar<br/>Imaginary component of a complex scalar, specified as a scalar.</p> <p>If b is <code>double</code>, you can use the character, i, without a multiplication sign as a suffix in forming the complex numerical constant.</p> <p><b>Example:</b> 7i</p> <p>If b is <code>single</code>, you must use a multiplication sign when forming the complex numerical constant.</p> <p><b>Example:</b> <code>single(7)*i</code></p> |

**Data Types**

single | double

**x - Real component of complex array**

scalar | vector | matrix | multidimensional array

Real component of a complex array, specified as a scalar, vector, matrix, or multidimensional array.

The size of  $x$  must match the size of  $y$ , unless one is a scalar. If either  $x$  or  $y$  is a scalar, MATLAB expands the scalar to match the size of the other input.

single can combine with double.

**Data Types**

single | double

**y - Imaginary component of complex array**

scalar | vector | matrix | multidimensional array

Imaginary component of a complex array, specified as a scalar, vector, matrix, or multidimensional array.

The size of  $x$  must match the size of  $y$ , unless one is a scalar. If either  $x$  or  $y$  is a scalar, MATLAB expands the scalar to match the size of the other input.

single can combine with double.

**Data Types**

single | double

**Output Arguments****z - Complex array**

scalar | vector | matrix | multidimensional array

Complex array, returned as a scalar, vector, matrix, or multidimensional array.

The size of  $z$  is the same as the input arguments.

`z` is `single` if at least one input argument is `single`. Otherwise, `z` is `double`.

## Examples

### Complex Scalar

Create a complex scalar and use the character, `i`, without a multiplication sign as a suffix in forming a complex numerical constant.

```
z = 1+2i
```

```
z =
```

```
1.0000 + 2.0000i
```

### Complex Vector

Create a complex vector from two 4-by-1 vectors of real numbers.

```
x = [1:4]';
```

```
y = [8:-2:2]';
```

```
z = x+1i*y
```

```
z =
```

```
1.0000 + 8.0000i
```

```
2.0000 + 6.0000i
```

```
3.0000 + 4.0000i
```

```
4.0000 + 2.0000i
```

`z` is a 4-by-1 complex vector.

### Complex Exponential

Create a complex scalar representing a complex vector with radius, `r`, and angle from the origin, `theta`.

```
r = 4;
```

```
theta = pi/4;
```

```
z = r*exp(1i*theta)
```

```
z =
```

```
2.8284 + 2.8284i
```

**Tips**

- For speed and improved robustness in complex arithmetic, use `1i` and `1j` instead of `i` and `j`.
- Since `i` is a function, it can be overridden and used as a variable. However, it is best to avoid using `i` and `j` for variable names if you intend to use them in complex arithmetic.
- Use the `complex` function to create a complex output in the following cases:
  - When the names `i` and `j` might be used for other variables (and do not equal `sqrt(-1)`)
  - When the inputs are not `double` or `single`
  - When the imaginary component is all zeros

**See Also**

```
conj | complex | imag | j | real
```

**Concepts**

- “Complex Numbers”



**Purpose** Incomplete Cholesky factorization

**Syntax**  
`L = ichol(A)`  
`L = ichol(A,opts)`

**Description** `L = ichol(A)` performs the incomplete Cholesky factorization of `A` with zero-fill.  
`L = ichol(A,opts)` performs the incomplete Cholesky factorization of `A` with options specified by `opts`.  
 By default, `ichol` references the lower triangle of `A` and produces lower triangular factors.

**Input Arguments** **A**  
 Sparse matrix

**opts**  
 Structure with up to five fields:

| Field Name | Summary               | Description                                                                                                                                                                                                                                                                 |
|------------|-----------------------|-----------------------------------------------------------------------------------------------------------------------------------------------------------------------------------------------------------------------------------------------------------------------------|
| type       | Type of factorization | String indicating which flavor of incomplete Cholesky to perform. Valid values of this field are 'nofill' and 'ict'. The 'nofill' variant performs <i>incomplete Cholesky with zero-fill (IC(0))</i> . The 'ict' variant performs <i>incomplete Cholesky with threshold</i> |

| Field Name | Summary                                                   | Description                                                                                                                                                                                                                                                                                                                                                                                                                                                                                                          |
|------------|-----------------------------------------------------------|----------------------------------------------------------------------------------------------------------------------------------------------------------------------------------------------------------------------------------------------------------------------------------------------------------------------------------------------------------------------------------------------------------------------------------------------------------------------------------------------------------------------|
| droptol    | Drop tolerance when type is 'ict'                         | <p><i>dropping</i> (ICT). The default value is 'nofill'.</p> <p>Nonnegative scalar used as a drop tolerance when performing ICT. Elements which are smaller in magnitude than a local drop tolerance are dropped from the resulting factor except for the diagonal element which is never dropped. The local drop tolerance at step <math>j</math> of the factorization is <math>\text{norm}(A(j:\text{end}, j), 1) * \text{droptol}</math>. 'droptol' is ignored if 'type' is 'nofill'. The default value is 0.</p> |
| michol     | Indicates whether to perform modified incomplete Cholesky | <p>Indicates whether or not <i>modified incomplete Cholesky</i> (MIC) is performed. The field may be 'on' or 'off'. When performing MIC, the diagonal is compensated for dropped elements to enforce the relationship <math>A * e = L * L' * e</math> where <math>e = \text{ones}(\text{size}(A, 2), 1)</math>. The default value is 'off'.</p>                                                                                                                                                                      |

| Field Name | Summary                                                                | Description                                                                                                                                                                                                                                                                                                                                           |
|------------|------------------------------------------------------------------------|-------------------------------------------------------------------------------------------------------------------------------------------------------------------------------------------------------------------------------------------------------------------------------------------------------------------------------------------------------|
| diagcomp   | Perform compensated incomplete Cholesky with the specified coefficient | Real nonnegative scalar used as a global diagonal shift $\alpha$ in forming the incomplete Cholesky factor. That is, instead of performing incomplete Cholesky on $A$ , the factorization of $A + \alpha \cdot \text{diag}(\text{diag}(A))$ is formed. The default value is 0.                                                                        |
| shape      | Determines which triangle is referenced and returned                   | Valid values are 'upper' and 'lower'. If 'upper' is specified, only the upper triangle of $A$ is referenced and $R$ is constructed such that $A$ is approximated by $R' * R$ . If 'lower' is specified, only the lower triangle of $A$ is referenced and $L$ is constructed such that $A$ is approximated by $L * L'$ . The default value is 'lower'. |

## Tips

- The factor given by this routine may be useful as a preconditioner for a system of linear equations being solved by iterative methods such as `pcg` or `minres`.
- `ichol` works only for sparse square matrices

## Examples

### Incomplete Cholesky Factorization

This example generates an incomplete Cholesky factorization.

Start with a symmetric positive definite matrix, A:

```
N = 100;
A = delsq(numgrid('S',N));
```

A is the two-dimensional, five-point discrete negative Laplacian on a 100-by-100 square grid with Dirichlet boundary conditions. The size of A is  $98 \times 98 = 9604$  (not 10000 as the borders of the grid are used to impose the Dirichlet conditions).

The no-fill incomplete Cholesky factorization is a factorization which contains only nonzeros in the same position as A contains nonzeros. This factorization is extremely cheap to compute. Although the product  $L^*L'$  is typically very different from A, the product  $L^*L'$  will match A on its pattern up to round-off.

```
L = ichol(A);
norm(A-L*L', 'fro') ./ norm(A, 'fro')
```

```
ans =
```

```
0.0916
```

```
norm(A - (L*L') .* spones(A), 'fro') ./ norm(A, 'fro')
```

```
ans =
```

```
4.9606e-17
```

`ichol` may also be used to generate incomplete Cholesky factorizations with threshold dropping. As the drop tolerance decreases, the factor tends to get more dense and the product  $L^*L'$  tends to be a better approximation of A. The following plots show the relative error of the incomplete factorization plotted against the drop tolerance as well as

the ratio of the density of the incomplete factors to the density of the complete Cholesky factor.

```
n = size(A,1);
ntols = 20;
droptol = logspace(-8,0,ntols);
nrm = zeros(1,ntols);
nz = zeros(1,ntols);
nzComplete = nnz(chol(A,'lower'));
for k = 1:ntols
 L = ichol(A,struct('type','ict','droptol',droptol(k)));
 nz(k) = nnz(L);
 nrm(k) = norm(A-L*L','fro')./norm(A,'fro');
end
figure; loglog(droptol,nrm,'LineWidth',2);
title('Drop tolerance vs norm(A-L*L','fro')./norm(A,'fro')');
figure; semilogx(droptol,nz./nzComplete,'LineWidth',2);
title('Drop tolerance vs fill ratio ichol/chol');
```

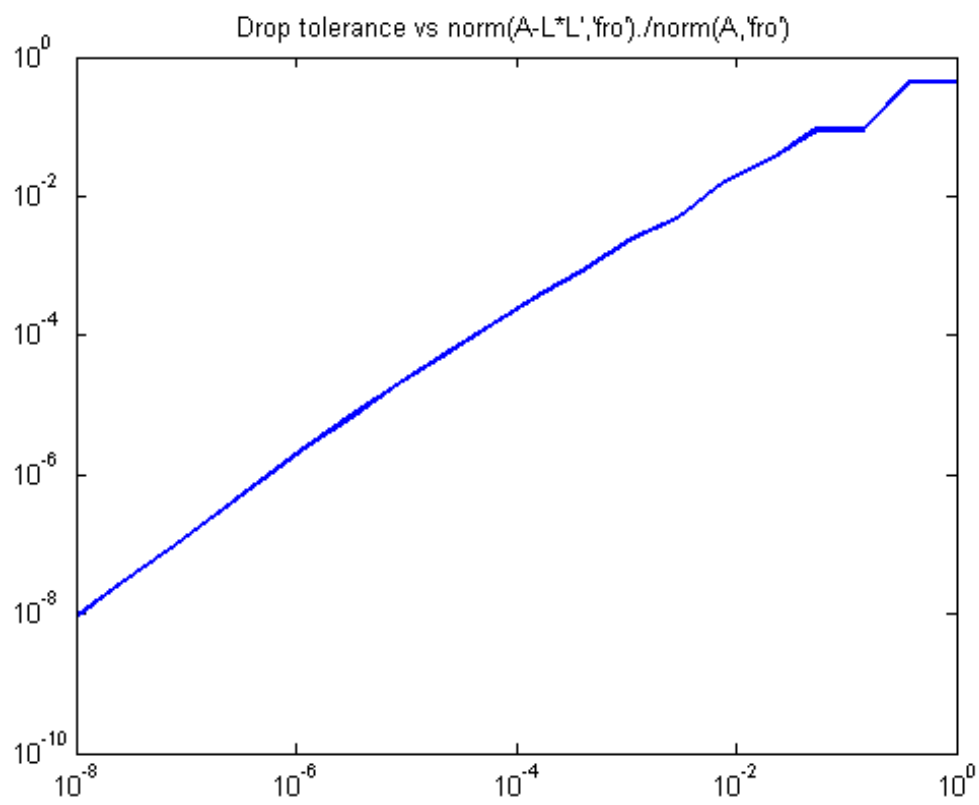

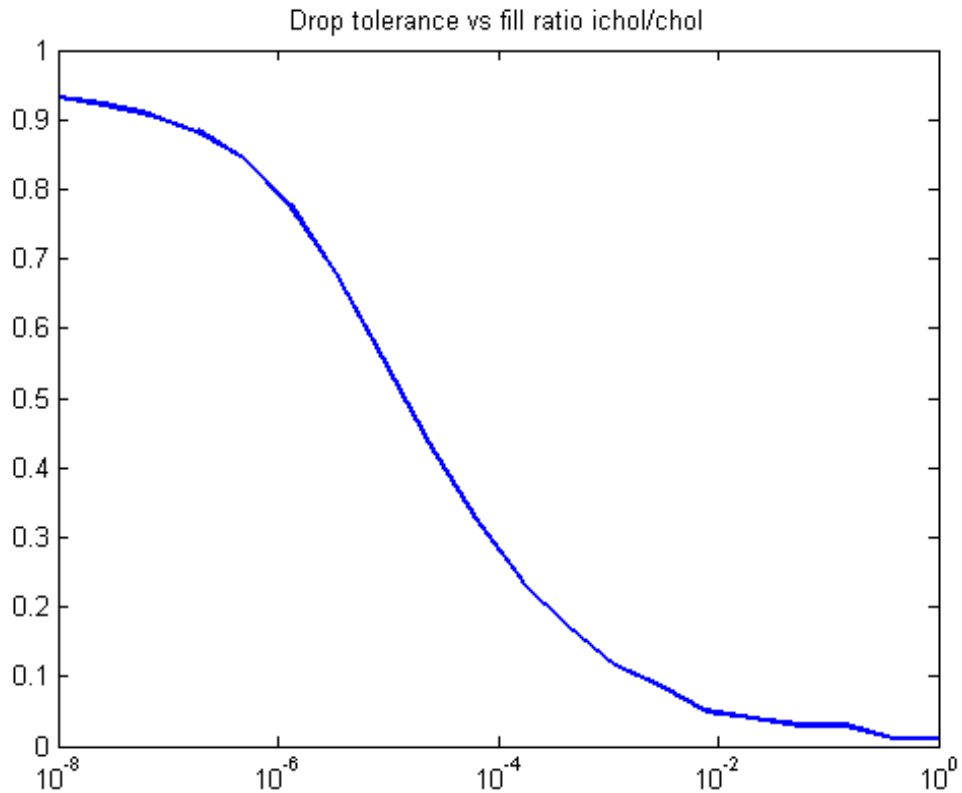

The relative error is typically on the same order as the drop tolerance, although this is not guaranteed.

### Using ichol as a Preconditioner

This example shows how to use an incomplete Cholesky factorization as a preconditioner to improve convergence.

Create a symmetric positive definite matrix, A.

```
N = 100;
```

```
A = delsq(numgrid('S',N));
```

Create an incomplete Cholesky factorization as a preconditioner for `pcg`. Use a constant vector as the right hand side. As a baseline, execute `pcg` without a preconditioner.

```
b = ones(size(A,1),1);
tol = 1e-6; maxit = 100;
[x0,f10,rr0,it0,rv0] = pcg(A,b,tol,maxit);
```

Note that `f10 = 1` indicating that `pcg` did not drive the relative residual to the requested tolerance in the maximum allowed iterations. Try the no-fill incomplete Cholesky factorization as a preconditioner.

```
L1 = ichol(A);
[x1,f11,rr1,it1,rv1] = pcg(A,b,tol,maxit,L1,L1');
```

`f11 = 0`, indicating that `pcg` converged to the requested tolerance and did so in 59 iterations (the value of `it1`). Since this matrix is a discretized Laplacian, however, using modified incomplete Cholesky can create a better preconditioner. A modified incomplete Cholesky factorization constructs an approximate factorization that preserves the action of the operator on the constant vector. That is,  $\text{norm}(A * e - L * (L' * e))$  will be approximately zero for  $e = \text{ones}(\text{size}(A,2),1)$  even though  $\text{norm}(A - L * L', 'fro') / \text{norm}(A, 'fro')$  is not close to zero. It is not necessary to specify type for this syntax since `nofill` is the default, but it is good practice.

```
opts.type = 'nofill'; opts.michol = 'on';
L2 = ichol(A,opts);
e = ones(size(A,2),1);
norm(A*e-L2*(L2'*e))
[x2,f12,rr2,it2,rv2] = pcg(A,b,tol,maxit,L2,L2');
```

```
ans =
```



---

3.7983e-14

pcg converges (f12 = 0) but in only 38 iterations. Plotting all three convergence histories shows the convergence.

```
semilogy(0:maxit,rv0./norm(b),'b. ');
hold on;
semilogy(0:it1,rv1./norm(b),'r. ');
semilogy(0:it2,rv2./norm(b),'k. ');
legend('No Preconditioner','IC(0)','MIC(0)');
```

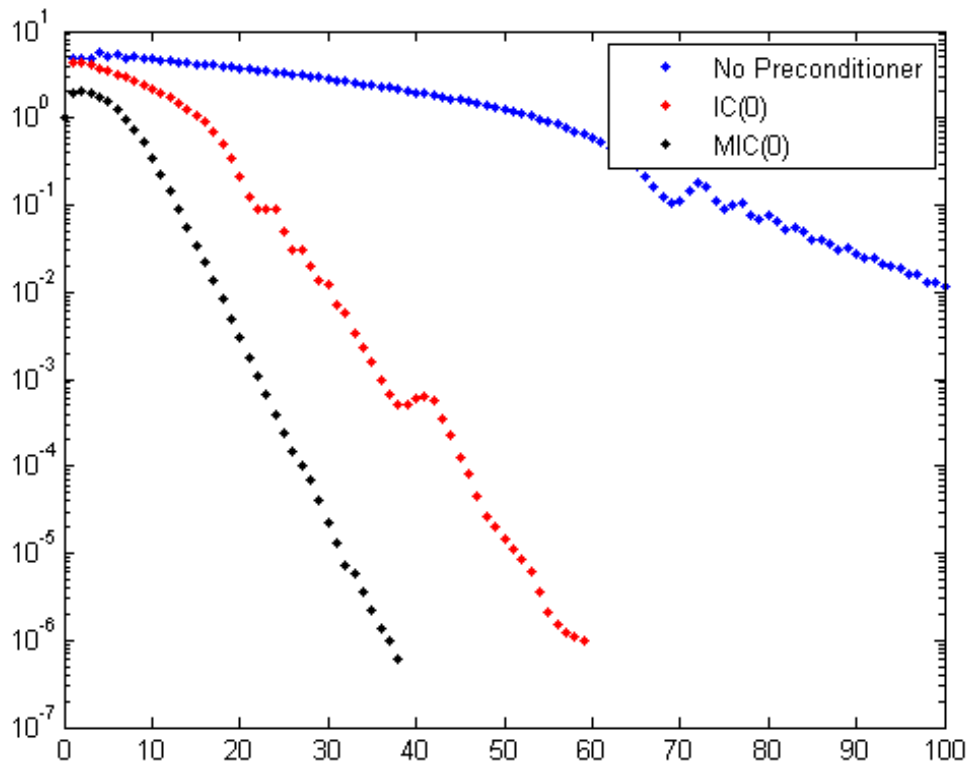

The plot shows that the modified incomplete Cholesky preconditioner creates a much faster convergence.

You can also try incomplete Cholesky factorizations with threshold dropping. The following plot shows convergence of `pcg` with preconditioners constructed with various drop tolerances.

```
L3 = ichol(A, struct('type','ict','droptol',1e-1));
[x3,f13,rr3,it3,rv3] = pcg(A,b,tol,maxit,L3,L3');
L4 = ichol(A, struct('type','ict','droptol',1e-2));
```

```
[x4,f14,rr4,it4,rv4] = pcg(A,b,tol,maxit,L4,L4');
L5 = ichol(A, struct('type','ict','droptol',1e-3));
[x5,f15,rr5,it5,rv5] = pcg(A,b,tol,maxit,L5,L5');
figure; semilogy(0:maxit,rv0./norm(b),'b-', 'linewidth',2);
hold on;
semilogy(0:it3,rv3./norm(b),'b-.', 'linewidth',2);
semilogy(0:it4,rv4./norm(b),'b--', 'linewidth',2);
semilogy(0:it5,rv5./norm(b),'b:', 'linewidth',2);
legend('No Preconditioner', 'ICT(1e-1)', 'ICT(1e-2)', ...
 'ICT(1e-3)', 'Location', 'SouthEast');
```

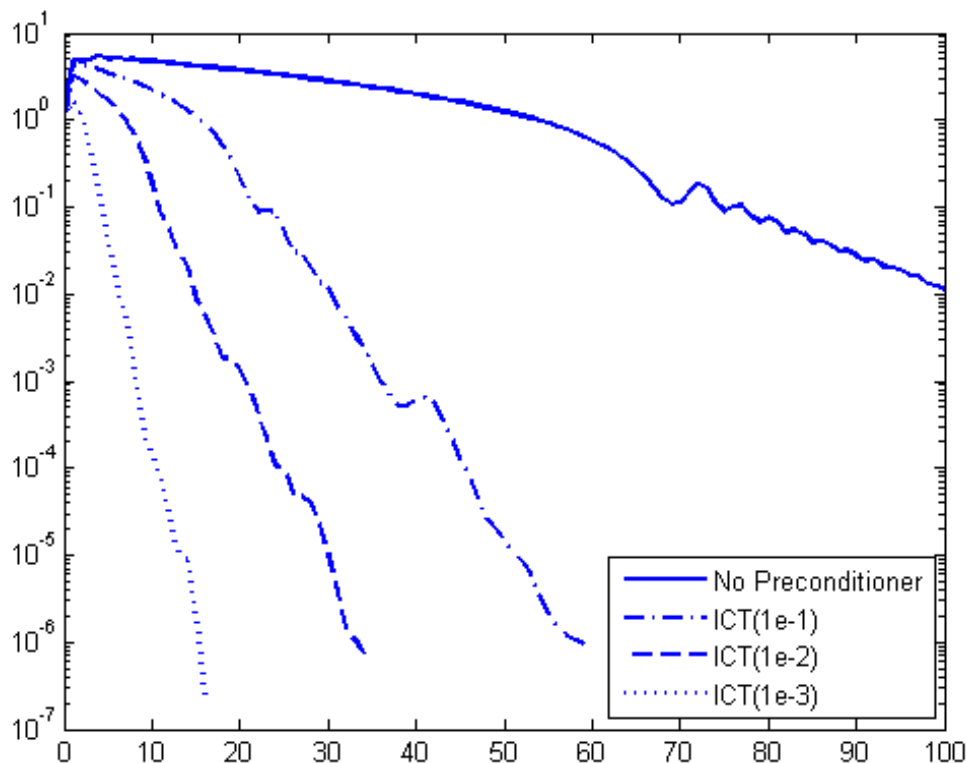

Note the incomplete Cholesky preconditioner constructed with drop tolerance  $1e-2$  is denoted as `ICT(1e-2)`.

As with the zero-fill incomplete Cholesky, the threshold dropping factorization can benefit from modification (i.e. `opts.michol = 'on'`) since the matrix arises from an elliptic partial differential equation. As with `MIC(0)`, the modified threshold based dropping incomplete Cholesky will preserve the action of the preconditioner on constant vectors, that is  $\text{norm}(A \cdot e - L \cdot (L' \cdot e))$  will be approximately zero.

## Using the diagcomp Option

This example illustrates the use of the `diagcomp` option of `ichol`.

Incomplete Cholesky factorizations of positive definite matrices do not always exist. The following code constructs a random symmetric positive definite matrix and attempts to solve a linear system using `pcg`.

```
S = rng('default');
A = sprandsym(1000,1e-2,1e-4,1);
rng(S);
b = full(sum(A,2));
[x0,f10,rr0,it0,rv0] = pcg(A,b,1e-6,100);
```

Since convergence is not attained, try to construct an incomplete Cholesky preconditioner.

```
L = ichol(A,struct('type','ict','droptol',1e-3));
```

```
Error using ichol
Encountered nonpositive pivot.
```

If `ichol` breaks down as above, you can use the `diagcomp` option to construct a shifted incomplete Cholesky factorization. That is, instead of constructing  $L$  such that  $L^*L$  approximates  $A$ , `ichol` with diagonal compensation constructs  $L$  such that  $L^*L$  approximates  $M = A + \alpha \cdot \text{diag}(\text{diag}(A))$  without explicitly forming  $M$ . As incomplete factorizations always exist for diagonally dominant matrices,  $\alpha$  can be found to make  $M$  diagonally dominant.

```
alpha = max(sum(abs(A),2)./diag(A))-2
```

```
alpha =
```

```
62.9341
```

```
L1 = ichol(A, struct('type','ict','droptol',1e-3,'diagcomp',alpha));
[x1,f11,rr1,it1,rv1] = pcg(A,b,1e-6,100,L1,L1');
```

Here, `pcg` still fails to converge to the desired tolerance within the desired number of iterations, but as the plot below shows, convergence is better for `pcg` with this preconditioner than with no preconditioner. Choosing a smaller `alpha` may help. With some experimentation, we can settle on an appropriate value for `alpha`.

```
alpha = .1;
L2 = ichol(A, struct('type','ict','droptol',1e-3,'diagcomp',alpha));
[x2,f12,rr2,it2,rv2] = pcg(A,b,1e-6,100,L2,L2');
```

Now, `pcg` converges and a plot can show the convergence histories with each preconditioner.

```
semilogy(0:100,rv0./norm(b),'b. ');
hold on;
semilogy(0:100,rv1./norm(b),'r. ');
semilogy(0:it2,rv2./norm(b),'k. ');
legend('No Preconditioner','\alpha \approx 63','\alpha = .1');
xlabel('Iteration Number');
ylabel('Relative Residual');
```

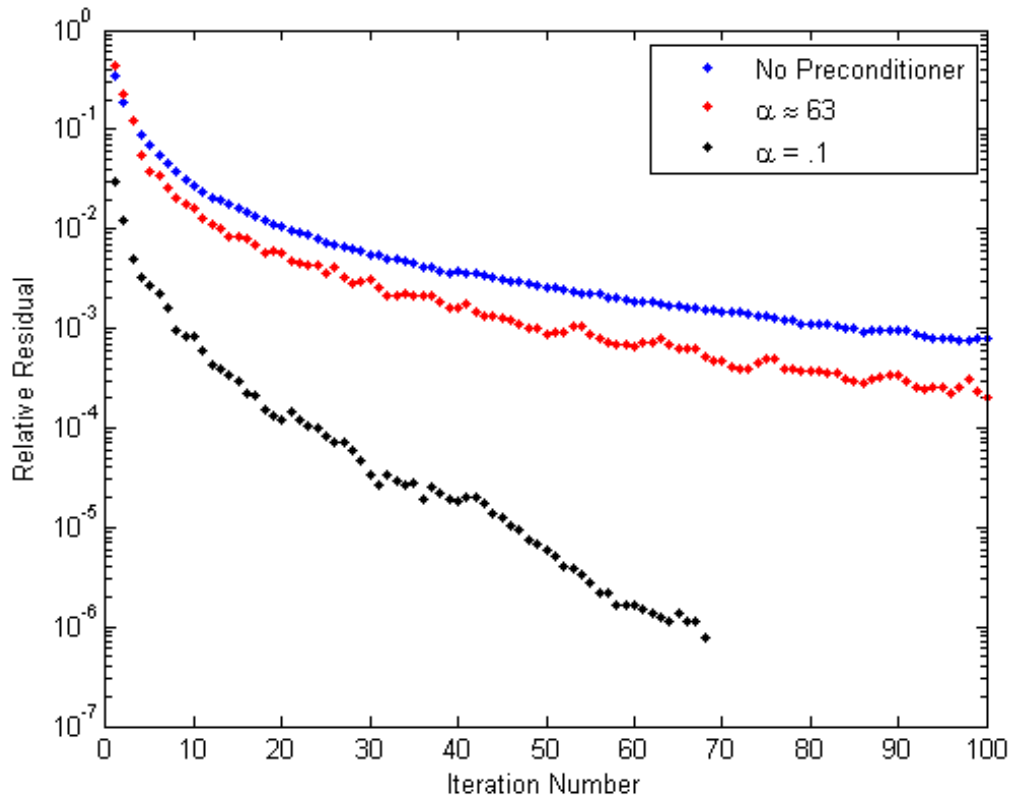

## References

- [1] Saad, Yousef. "Preconditioning Techniques." *Iterative Methods for Sparse Linear Systems*. PWS Publishing Company, 1996.
- [2] Manteuffel, T.A. "An incomplete factorization technique for positive definite linear systems." *Math. Comput.* 34, 473–497, 1980.

## See Also

ilu | chol | pcg | minres

# idivide

---

**Purpose** Integer division with rounding option

**Syntax**

```
C = idivide(A, B, opt)
C = idivide(A, B)
C = idivide(A, B, 'fix')
C = idivide(A, B, 'round')
C = idivide(A, B, 'floor')
C = idivide(A, B, 'ceil')
```

**Description** `C = idivide(A, B, opt)` is the same as `A./B` for integer classes except that fractional quotients are rounded to integers using the optional rounding mode specified by `opt`. The default rounding mode is `'fix'`. Inputs `A` and `B` must be real and must have the same dimensions unless one is a scalar. At least one of the arguments `A` and `B` must belong to an integer class, and the other must belong to the same integer class or be a scalar double. The result `C` belongs to the integer class.

`C = idivide(A, B)` is the same as `A./B` except that fractional quotients are rounded toward zero to the nearest integers.

`C = idivide(A, B, 'fix')` is the same as the syntax shown immediately above.

`C = idivide(A, B, 'round')` is the same as `A./B` for integer classes. Fractional quotients are rounded to the nearest integers.

`C = idivide(A, B, 'floor')` is the same as `A./B` except that fractional quotients are rounded toward negative infinity to the nearest integers.

`C = idivide(A, B, 'ceil')` is the same as `A./B` except that the fractional quotients are rounded toward infinity to the nearest integers.

## Examples

```
a = int32([-2 2]);
b = int32(3);

idivide(a,b) % Returns [0 0]
idivide(a,b,'floor') % Returns [-1 0]
idivide(a,b,'ceil') % Returns [0 1]
```



```
idivide(a,b,'round') % Returns [-1 1]
```

## See Also

```
ceil | floor | fix | round | rdivide | ldivide
```

# if, elseif, else

---

**Purpose** Execute statements if condition is true

**Syntax**

```
if expression
 statements
elseif expression
 statements
else
 statements
end
```

**Description** `if expression, statements, end` evaluates an expression, and executes a group of statements when the expression is true.

`elseif` and `else` are optional, and execute statements only when previous expressions in the `if` block are false. An `if` block can include multiple `elseif` statements.

An evaluated expression is true when the result is nonempty and contains all nonzero elements (logical or real numeric). Otherwise, the expression is false.

Expressions can include relational operators (such as `<` or `==`) and logical operators (such as `&&`, `||`, or `~`). MATLAB evaluates compound expressions from left to right, adhering to operator precedence rules.

---

**Note** Within the condition *expression* of an `if` or `while` statement, logical operators `&` and `|` behave as short-circuit operators. This behavior is the same as `&&` and `||`, respectively. Since `&&` and `||` consistently short-circuit in `if` and `while` condition expressions and statements, it is good practice to use `&&` and `||` instead of `&` and `|` within *expression*.

---

**Tips**

- You can nest any number of `if` statements. Each `if` statement requires an `end` keyword.

- Avoid adding a space within the `elseif` keyword (`else if`). The space creates a nested `if` statement that requires its own `end` keyword.

## Examples

Assign to a matrix values that depend on their indices.

```
% Preallocate a matrix
nrows = 10;
ncols = 10;
myData = ones(nrows, ncols);

% Loop through the matrix
for r = 1:nrows
 for c = 1:ncols

 if r == c
 myData(r,c) = 2;
 elseif abs(r - c) == 1
 myData(r,c) = -1;
 else
 myData(r,c) = 0;
 end

 end
end
```

---

Respond to command-line input. Because the input string could be more than one character, use `strcmp` rather than `==` to test for equality.

```
reply = input('Would you like to see an echo? (y/n): ', 's');
if strcmp(reply, 'y')
 disp(reply)
end
```

---

## if, elseif, else

---

Find the indices of values in a vector that are greater than a specified limit.

```
A = rand(1,10);
limit = .75;

B = (A > limit); % B is a vector of logical values
if any(B)
 fprintf('Indices of values > %4.2f: \n', limit);
 disp(find(B))
else
 disp('All values are below the limit.')
end
```

---

Concatenate two variables when they are the same size. To avoid an error when the variables have different dimensions, compare the sizes using `isequal` rather than the `==` operator.

```
A = ones(2,3); % Two-dimensional array
B = rand(3,4,5); % Three-dimensional array

if isequal(size(A), size(B))
 C = [A; B];
else
 warning('A and B are not the same size.');
```

```
C = [];
```

```
end
```

---

Take advantage of short-circuiting to avoid error or warning messages.

```
x = 42;
if exist('myfunction.m') && (myfunction(x) >= pi)
 disp('Condition is true')
end
```

**See Also**      for | while | switch | return | Logical Operators: Short  
Circuit

**Concepts**      • “Relational Operators”

**Purpose** Inverse fast Fourier transform

**Syntax**

```
y = ifft(X)
y = ifft(X,n)
y = ifft(X,[],dim)
y = ifft(X,n,dim)
y = ifft(..., 'symmetric')
y = ifft(..., 'nonsymmetric')
```

**Description** `y = ifft(X)` returns the inverse discrete Fourier transform (DFT) of vector `X`, computed with a fast Fourier transform (FFT) algorithm. If `X` is a matrix, `ifft` returns the inverse DFT of each column of the matrix.

`ifft` tests `X` to see whether vectors in `X` along the active dimension are *conjugate symmetric*. If so, the computation is faster and the output is real. An `N`-element vector `x` is conjugate symmetric if  $x(i) = \text{conj}(x(\text{mod}(N-i+1,N)+1))$  for each element of `x`.

If `X` is a multidimensional array, `ifft` operates on the first non-singleton dimension.

`y = ifft(X,n)` returns the `n`-point inverse DFT of vector `X`.

`y = ifft(X,[],dim)` and `y = ifft(X,n,dim)` return the inverse DFT of `X` across the dimension `dim`.

`y = ifft(..., 'symmetric')` causes `ifft` to treat `X` as conjugate symmetric along the active dimension. This option is useful when `X` is not exactly conjugate symmetric, merely because of round-off error.

`y = ifft(..., 'nonsymmetric')` is the same as calling `ifft(...)` without the argument `'nonsymmetric'`.

For any `X`, `ifft(fft(X))` equals `X` to within roundoff error.

**Algorithms** The algorithm for `ifft(X)` is the same as the algorithm for `fft(X)`, except for a sign change and a scale factor of  $n = \text{length}(X)$ . As for `fft`, the execution time for `ifft` depends on the length of the transform. It is fastest for powers of two. It is almost as fast for lengths that have

---

only small prime factors. It is typically several times slower for lengths that are prime or which have large prime factors.

---

**Note** You might be able to increase the speed of `ifft` using the utility function `fftw`, which controls how MATLAB software optimizes the algorithm used to compute an FFT of a particular size and dimension.

---

### Data Type Support

`ifft` supports inputs of data types `double` and `single`. If you call `ifft` with the syntax `y = ifft(X, ...)`, the output `y` has the same data type as the input `X`.

### See Also

`fft` | `fft2` | `ifft2` | `ifftn` | `ifftshift` | `fftw`

**Purpose** 2-D inverse fast Fourier transform

**Syntax**

```
Y = ifft2(X)
Y = ifft2(X,m,n)
y = ifft2(..., 'symmetric')
y = ifft2(..., 'nonsymmetric')
```

**Description** `Y = ifft2(X)` returns the two-dimensional inverse discrete Fourier transform (DFT) of `X`, computed with a fast Fourier transform (FFT) algorithm. The result `Y` is the same size as `X`.

`ifft2` tests `X` to see whether it is *conjugate symmetric*. If so, the computation is faster and the output is real. An `M`-by-`N` matrix `X` is conjugate symmetric if  $X(i,j) = \text{conj}(X(\text{mod}(M-i+1, M) + 1, \text{mod}(N-j+1, N) + 1))$  for each element of `X`.

`Y = ifft2(X,m,n)` returns the `m`-by-`n` inverse fast Fourier transform of matrix `X`.

`y = ifft2(..., 'symmetric')` causes `ifft2` to treat `X` as conjugate symmetric. This option is useful when `X` is not exactly conjugate symmetric, merely because of round-off error.

`y = ifft2(..., 'nonsymmetric')` is the same as calling `ifft2(...)` without the argument `'nonsymmetric'`.

For any `X`, `ifft2(fft2(X))` equals `X` to within roundoff error.

**Algorithms** The algorithm for `ifft2(X)` is the same as the algorithm for `fft2(X)`, except for a sign change and scale factors of `[m,n] = size(X)`. The execution time for `ifft2` depends on the length of the transform. It is fastest for powers of two. It is almost as fast for lengths that have only small prime factors. It is typically several times slower for lengths that are prime or which have large prime factors.



---

**Note** You might be able to increase the speed of `iff2` using the utility function `fftw`, which controls how MATLAB software optimizes the algorithm used to compute an FFT of a particular size and dimension.

---

### Data Type Support

`iff2` supports inputs of data types `double` and `single`. If you call `iff2` with the syntax `y = iff2(X, ...)`, the output `y` has the same data type as the input `X`.

### See Also

`fft2` | `fftw` | `fftshift` | `ifft` | `ifftn` | `ifftshift`

**Purpose** N-D inverse fast Fourier transform

**Syntax**

```
Y = ifftn(X)
Y = ifftn(X,siz)
y = ifftn(..., 'symmetric')
y = ifftn(..., 'nonsymmetric')
```

**Description** `Y = ifftn(X)` returns the n-dimensional inverse discrete Fourier transform (DFT) of `X`, computed with a multidimensional fast Fourier transform (FFT) algorithm. The result `Y` is the same size as `X`.

`ifftn` tests `X` to see whether it is *conjugate symmetric*. If so, the computation is faster and the output is real. An  $N_1$ -by- $N_2$ -by- ...  $N_k$  array `X` is conjugate symmetric if

$$X(i_1, i_2, \dots, i_k) = \text{conj}(X(\text{mod}(N_1 - i_1 + 1, N_1) + 1, \text{mod}(N_2 - i_2 + 1, N_2) + 1, \dots, \text{mod}(N_k - i_k + 1, N_k) + 1))$$

for each element of `X`.

`Y = ifftn(X,siz)` pads `X` with zeros, or truncates `X`, to create a multidimensional array of size `siz` before performing the inverse transform. The size of the result `Y` is `siz`.

`y = ifftn(..., 'symmetric')` causes `ifftn` to treat `X` as conjugate symmetric. This option is useful when `X` is not exactly conjugate symmetric, merely because of round-off error.

`y = ifftn(..., 'nonsymmetric')` is the same as calling `ifftn(...)` without the argument `'nonsymmetric'`.

**Tips** For any `X`, `ifftn(fftn(X))` equals `X` within roundoff error.

**Algorithms** `ifftn(X)` is equivalent to

```
Y = X;
for p = 1:length(size(X))
 Y = ifft(Y,[],p);
end
```

This computes in-place the one-dimensional inverse DFT along each dimension of  $X$ .

The execution time for `ifftn` depends on the length of the transform. It is fastest for powers of two. It is almost as fast for lengths that have only small prime factors. It is typically several times slower for lengths that are prime or which have large prime factors.

---

**Note** You might be able to increase the speed of `ifftn` using the utility function `fftw`, which controls how MATLAB software optimizes the algorithm used to compute an FFT of a particular size and dimension.

---

## Data Type Support

`ifftn` supports inputs of data types `double` and `single`. If you call `ifftn` with the syntax `y = ifftn(X, ...)`, the output `y` has the same data type as the input `X`.

## See Also

`fftn` | `fftw` | `ifft` | `ifft2` | `ifftshift`

# ifftshift

---

**Purpose** Inverse FFT shift

**Syntax** `ifftshift(X)`  
`ifftshift(X,dim)`

**Description** `ifftshift(X)` swaps the left and right halves of the vector  $X$ . For matrices, `ifftshift(X)` swaps the first quadrant with the third and the second quadrant with the fourth. If  $X$  is a multidimensional array, `ifftshift(X)` swaps “half-spaces” of  $X$  along each dimension.

`ifftshift(X,dim)` applies the `ifftshift` operation along the dimension `dim`.

---

**Note** `ifftshift` undoes the results of `fftshift`. If the matrix  $X$  contains an odd number of elements, `ifftshift(fftshift(X))` must be done to obtain the original  $X$ . Simply performing `fftshift(X)` twice will not produce  $X$ .

---

**See Also** `fft` | `fft2` | `fftn` | `fftshift`

**Purpose** Sparse incomplete LU factorization

**Syntax**

```
ilu(A,setup)
[L,U] = ilu(A,setup)
[L,U,P] = ilu(A,setup)
```

**Description** `ilu` produces a unit lower triangular matrix, an upper triangular matrix, and a permutation matrix.

`ilu(A,setup)` computes the incomplete LU factorization of `A`. `setup` is an input structure with up to five setup options. The fields must be named exactly as shown in the table below. You can include any number of these fields in the structure and define them in any order. Any additional fields are ignored.

| Field Name           | Description                                                                                                                                                                                                                                                                                                                                                                                                                                                                                                                                                                                                                                                                                                                                                                                                                 |
|----------------------|-----------------------------------------------------------------------------------------------------------------------------------------------------------------------------------------------------------------------------------------------------------------------------------------------------------------------------------------------------------------------------------------------------------------------------------------------------------------------------------------------------------------------------------------------------------------------------------------------------------------------------------------------------------------------------------------------------------------------------------------------------------------------------------------------------------------------------|
| <code>type</code>    | <p>Type of factorization. Values for <code>type</code> include:</p> <ul style="list-style-type: none"> <li>'nofill' (default)—Performs ILU factorization with 0 level of fill in, known as ILU(0). With <code>type</code> set to 'nofill', only the <code>milu</code> setup option is used; all other fields are ignored.</li> <li>'crout'—Performs the Crout version of ILU factorization, known as ILUC. With <code>type</code> set to 'crout', only the <code>droptol</code> and <code>milu</code> setup options are used; all other fields are ignored.</li> <li>'ilutp'—Performs ILU factorization with threshold and pivoting.</li> </ul> <p>If <code>type</code> is not specified, the ILU factorization with 0 level of fill in is performed. Pivoting is only performed with <code>type</code> set to 'ilutp'.</p> |
| <code>droptol</code> | <p>Drop tolerance of the incomplete LU factorization. <code>droptol</code> is a non-negative scalar. The default value is 0, which produces the complete LU factorization.</p>                                                                                                                                                                                                                                                                                                                                                                                                                                                                                                                                                                                                                                              |

| Field Name | Description                                                                                                                                                                                                                                                                                                                                                                                                                                                                                                                                                                                                                                                                                                                                                                  |
|------------|------------------------------------------------------------------------------------------------------------------------------------------------------------------------------------------------------------------------------------------------------------------------------------------------------------------------------------------------------------------------------------------------------------------------------------------------------------------------------------------------------------------------------------------------------------------------------------------------------------------------------------------------------------------------------------------------------------------------------------------------------------------------------|
|            | <p>The nonzero entries of U satisfy</p> $\text{abs}(U(i,j)) \geq \text{droptol} * \text{norm}(A(:,j)),$ <p>with the exception of the diagonal entries, which are retained regardless of satisfying the criterion. The entries of L are tested against the local drop tolerance before being scaled by the pivot, so for nonzeros in L</p> $\text{abs}(L(i,j)) \geq \text{droptol} * \text{norm}(A(:,j)) / U(j,j).$                                                                                                                                                                                                                                                                                                                                                           |
| milu       | <p>Modified incomplete LU factorization. Values for milu include:</p> <ul style="list-style-type: none"> <li>• 'row'—Produces the row-sum modified incomplete LU factorization. Entries from the newly-formed column of the factors are subtracted from the diagonal of the upper triangular factor, U, preserving column sums. That is, <math>A * e = L * U * e</math>, where e is the vector of ones.</li> <li>• 'col'—Produces the column-sum modified incomplete LU factorization. Entries from the newly-formed column of the factors are subtracted from the diagonal of the upper triangular factor, U, preserving column sums. That is, <math>e' * A = e' * L * U</math>.</li> <li>• 'off' (default)—No modified incomplete LU factorization is produced.</li> </ul> |
| udiag      | <p>If udiag is 1, any zeros on the diagonal of the upper triangular factor are replaced by the local drop tolerance. The default is 0.</p>                                                                                                                                                                                                                                                                                                                                                                                                                                                                                                                                                                                                                                   |
| thresh     | <p>Pivot threshold between 0 (forces diagonal pivoting) and 1, the default, which always chooses the maximum magnitude entry in the column to be the pivot.</p>                                                                                                                                                                                                                                                                                                                                                                                                                                                                                                                                                                                                              |

`ilu(A,setup)` returns `L+U-speye(size(A))`, where `L` is a unit lower triangular matrix and `U` is an upper triangular matrix.

`[L,U] = ilu(A,setup)` returns a unit lower triangular matrix in `L` and an upper triangular matrix in `U`.

`[L,U,P] = ilu(A,setup)` returns a unit lower triangular matrix in `L`, an upper triangular matrix in `U`, and a permutation matrix in `P`.

## Tips

These incomplete factorizations may be useful as preconditioners for a system of linear equations being solved by iterative methods such as BICG (BiConjugate Gradients), GMRES (Generalized Minimum Residual Method).

## Limitations

`ilu` works on sparse square matrices only.

## Examples

Start with a sparse matrix and compute the LU factorization.

```
A = gallery('neumann', 1600) + speye(1600);
setup.type = 'crout';
setup.milu = 'row';
setup.droptol = 0.1;
[L,U] = ilu(A,setup);
e = ones(size(A,2),1);
norm(A*e-L*U*e)
```

ans =

```
1.4251e-014
```

This shows that `A` and `L*U`, where `L` and `U` are given by the modified Crout ILU, have the same row-sum.

Start with a sparse matrix and compute the LU factorization.

```
A = gallery('neumann', 1600) + speye(1600);
setup.type = 'nofill';
nnz(A)
```

```
ans =

 7840

nnz(lu(A))
ans =

 126478

nnz(ilu(A,setup))
ans =

 7840
```

This shows that A has 7840 nonzeros, the complete LU factorization has 126478 nonzeros, and the incomplete LU factorization, with 0 level of fill-in, has 7840 nonzeros, the same amount as A.

## References

[1] Saad, Yousef, *Iterative Methods for Sparse Linear Systems*, PWS Publishing Company, 1996, Chapter 10 - Preconditioning Techniques.

## See Also

bicg | ichol | gmres



**Purpose** Convert image to movie frame

**Syntax**  
`f = im2frame(X,map)`  
`f = im2frame(X)`

**Description** `f = im2frame(X,map)` converts the indexed image, `X`, and the associated colormap, `map`, into a movie frame `f`.

- If you specify `X` as an `m`-by-`n` array of integers, then `im2frame` uses the associated colormap, `map`, where `map` is a three-column array of values in the range `[0,1]`. Each row of `map` is a three-element RGB triplet that specifies the red, green, and blue components of a single color of the colormap.
- If you specify `X` as an `m`-by-`n`-by-3 truecolor image, then `map` is optional and has no effect.

`f = im2frame(X)` converts the indexed image, `X`, into a movie frame `f` using the current colormap if `X` contains an indexed image.

For more information on image types, see “Image Types”.

**Class Support** `X` must be of class `uint8` or `double`.

### Examples **Convert Image Sequence to Movie**

Use `im2frame` to convert a sequence of images into a movie.

```
F(1) = im2frame(X1,map);
F(2) = im2frame(X2,map);
...
F(n) = im2frame(Xn,map);
movie(F)
```

**See Also** `frame2im` | `movie`

# im2java

---

**Purpose** Convert image to Java image

**Syntax**

```
jimage = im2java(I)
jimage = im2java(X,MAP)
jimage = im2java(RGB)
```

**Description** To work with a MATLAB image in the Java environment, you must convert the image from its MATLAB representation into an instance of the Java image class, `java.awt.Image`.

`jimage = im2java(I)` converts the intensity image `I` to an instance of the Java image class, `java.awt.Image`.

`jimage = im2java(X,MAP)` converts the indexed image `X`, with colormap `MAP`, to an instance of the Java image class, `java.awt.Image`.

`jimage = im2java(RGB)` converts the RGB image `RGB` to an instance of the Java image class, `java.awt.Image`.

**Class Support** The input image can be of class `uint8`, `uint16`, or `double`.

---

**Note** Java requires `uint8` data to create an instance of the Java image class, `java.awt.Image`. If the input image is of class `uint8`, `jimage` contains the same `uint8` data. If the input image is of class `double` or `uint16`, `im2java` makes an equivalent image of class `uint8`, rescaling or offsetting the data as necessary, and then converts this `uint8` representation to an instance of the Java image class, `java.awt.Image`.

---

**Examples** This example reads an image into the MATLAB workspace and then uses `im2java` to convert it into an instance of the Java image class.

```
I = imread('ngc6543a.jpg');
javaImage = im2java(I);
frame = javax.swing.JFrame;
icon = javax.swing.ImageIcon(javaImage);
label = javax.swing.JLabel(icon);
```

```
frame.getContentPane.add(label);
frame.pack
frame.show
```

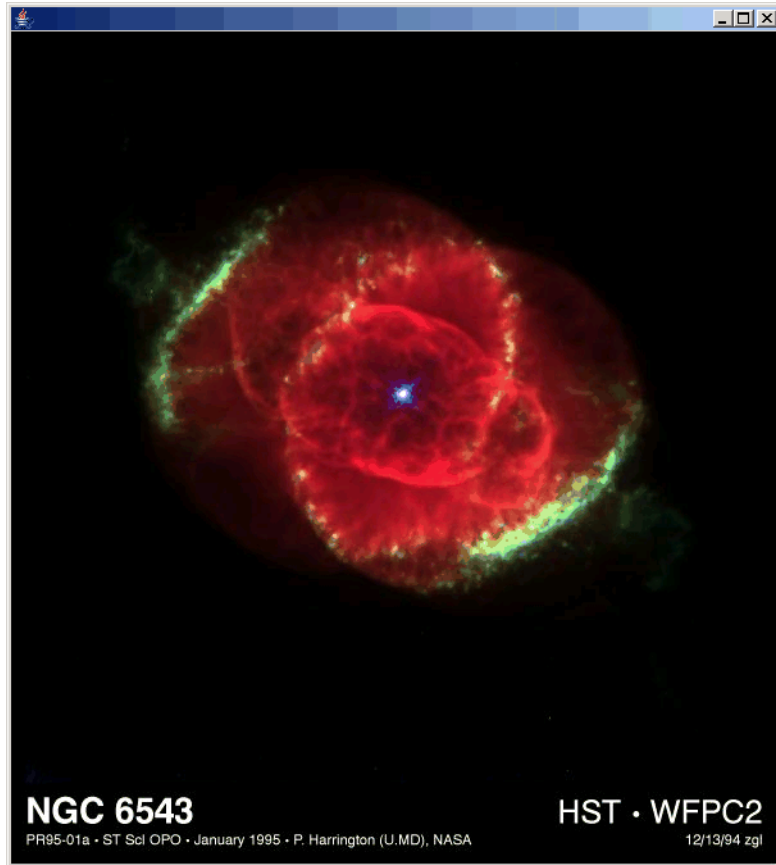

# imag

---

**Purpose**            Imaginary part of complex number

**Syntax**             $Y = \text{imag}(Z)$

**Description**       $Y = \text{imag}(Z)$  returns the imaginary part of the elements of array  $Z$ .

**Examples**             $\text{imag}(2+3i)$

ans =

3

**See Also**            `conj` | `i` | `j` | `real`

**Purpose**

Display image object

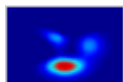
**Syntax**

```
image(C)
image(x,y,C)
image(x,y,C,'PropertyName',PropertyValue,...)
image('PropertyName',PropertyValue,...)
handle = image(...)
```

**Properties**

For a list of properties, see Image Properties.

**Description**

`image` creates an image graphics object by interpreting each element in a matrix as an index into the figure's colormap or directly as RGB values, depending on the data specified.

The `image` function has two forms:

- A high-level function that calls `newplot` to determine where to draw the graphics objects and sets the following axes properties:
  - `XLim` and `YLim` to enclose the image
  - Layer to top to place the image in front of the tick marks and grid lines
  - `YDir` to reverse
  - `View` to `[0 90]`
- A low-level function that adds the image to the current axes without calling `newplot`. The low-level function argument list can contain only property name/property value pairs.

You can specify properties as property name/property value pairs, structure arrays, and cell arrays (see `set` and `get` for examples of how to specify these data types).

`image(C)` displays matrix `C` as an image. Each element of `C` specifies the color of a rectangular segment in the image.

`image(x,y,C)`, where `x` and `y` are two-element vectors, specifies the range of the `x`- and `y`-axis labels, but produces the same image as `image(C)`. This can be useful, for example, if you want the axis tick labels to correspond to real physical dimensions represented by the image. If `x(1) > x(2)` or `y(1) > y(2)`, the image is flipped left-right or up-down, respectively. It can also be useful when you want to place the image within a set of axes already created. In this case, use `hold on` with the current figure and enter `x` and `y` values corresponding to the corners of the desired image location. The image is stretched and oriented as applicable.

`image(x,y,C,'PropertyName',PropertyValue,...)` is a high-level function that also specifies property name/property value pairs. For a description of the properties, see Image Properties. This syntax calls `newplot` before drawing the image.

`image('PropertyName',PropertyValue,...)` is the low-level syntax of the `image` function. It specifies only property name/property value pairs as input arguments.

`handle = image(...)` returns the handle of the image object it creates. You can obtain the handle with all forms of the `image` function.

## Tips

Image data can be either indexed or true color. An indexed image stores colors as an array of indices into the figure colormap. A true color image does not use a colormap; instead, the color values for each pixel are stored directly as RGB triplets. In MATLAB graphics, the `CData` property of a truecolor image object is a three-dimensional (`m`-by-`n`-by-3) array. This array consists of three `m`-by-`n` matrices (representing the red, green, and blue color planes) concatenated along the third dimension.

The `imread` function reads image data into MATLAB arrays from graphics files in various standard formats, such as TIFF. You can write MATLAB image data to graphics files using the `imwrite` function. `imread` and `imwrite` both support a variety of graphics file formats and compression schemes.

When you read image data into the MATLAB workspace using `imread`, the data is usually stored as an array of 8-bit integers. However, `imread` also supports reading 16-bit-per-pixel data from TIFF and PNG files. These are more efficient storage methods than the double-precision (64-bit) floating-point numbers that MATLAB typically uses. However, it is necessary to interpret 8-bit and 16-bit image data differently from 64-bit data. This table summarizes these differences.

You cannot interactively pan or zoom outside the  $x$ -limits or  $y$ -limits of an image, unless the axes limits are already been set outside the bounds of the image, in which case there is no such restriction. If other objects (such as lineseries) occupy the axes and extend beyond the bounds of the image, you can pan or zoom to the bounds of the other objects, but no further.

| <b>Image Type</b>  | <b>Double-Precision Data (double Array)</b>                                                                                                                                   | <b>8-Bit Data (uint8 Array)<br/>16-Bit Data (uint16 Array)</b>                                                                                                                                  |
|--------------------|-------------------------------------------------------------------------------------------------------------------------------------------------------------------------------|-------------------------------------------------------------------------------------------------------------------------------------------------------------------------------------------------|
| Indexed (colormap) | Image is stored as a two-dimensional (m-by-n) array of integers in the range [1, length(colormap)]; colormap is an m-by-3 array of floating-point values in the range [0, 1]. | Image is stored as a two-dimensional (m-by-n) array of integers in the range [0, 255] (uint8) or [0, 65535] (uint16); colormap is an m-by-3 array of floating-point values in the range [0, 1]. |
| True color (RGB)   | Image is stored as a three-dimensional (m-by-n-by-3) array of floating-point values in the range [0, 1].                                                                      | Image is stored as a three-dimensional (m-by-n-by-3) array of integers in the range [0, 255] (uint8) or [0, 65535] (uint16).                                                                    |

By default, `image` plots the  $y$ -axis from lowest to highest value, top to bottom. To reverse this, type `set(gca, 'YDir', 'normal')`. This will reverse both the  $y$ -axis and the image.

## Indexed Images

In an indexed image of class `double`, the value 1 points to the first row in the colormap, the value 2 points to the second row, and so on. In a `uint8` or `uint16` indexed image, there is an offset; the value 0 points to the first row in the colormap, the value 1 points to the second row, and so on.

If you want to convert a `uint8` or `uint16` indexed image to `double`, you need to add 1 to the result. For example,

```
X64 = double(X8) + 1;
```

or

```
X64 = double(X16) + 1;
```

To convert from `double` to `uint8` or `uint16`, you need to first subtract 1, and then use `round` to ensure all the values are integers.

```
X8 = uint8(round(X64 - 1));
```

or

```
X16 = uint16(round(X64 - 1));
```

When you write an indexed image using `imwrite`, values are automatically converted if necessary.

## Colormaps

MATLAB colormaps are always `m`-by-3 arrays of double-precision floating-point numbers in the range [0, 1]. In most graphics file formats, colormaps are stored as integers, but MATLAB colormaps cannot have integer values. `imread` and `imwrite` automatically convert colormap values when reading and writing files.

## True Color Images

In a true color image of class `double`, the data values are floating-point numbers in the range [0, 1]. In a true color image of class `uint8`, the



data values are integers in the range [0, 255], and for true color images of class `uint16` the data values are integers in the range [0, 65535].

If you want to convert a true color image from one data type to the other, you must rescale the data. For example, this statement converts a `uint8` true color image to `double`.

```
RGB64 = double(RGB8)/255;
```

or for `uint16` images,

```
RGB64 = double(RGB16)/65535;
```

This statement converts a `double` true color image to `uint8`:

```
RGB8 = uint8(round(RGB64*255));
```

or to obtain `uint16` images, type

```
RGB16 = uint16(round(RGB64*65535));
```

When you write a true color image using `imwrite`, values are automatically converted if necessary.

## Examples

### Load MAT-File and Display Image

Load the `mandrill` file which contains an indexed image, `X`, and its associated colormap, `map`. Display the image using its colormap.

```
load mandrill
image(X)
colormap(map)
```

# image

---

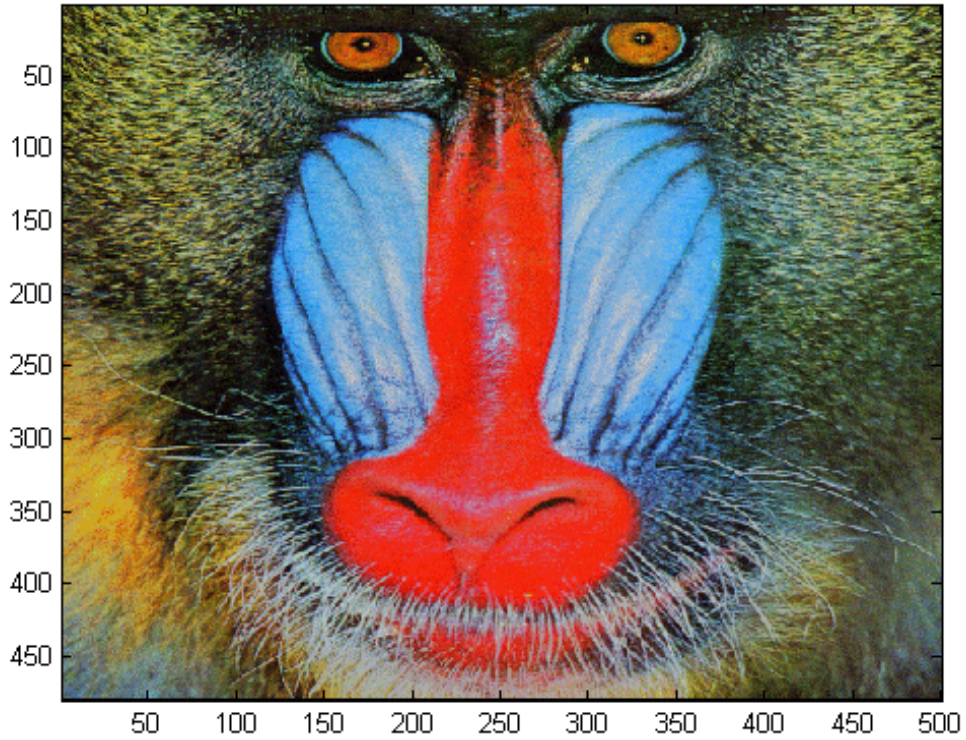

Remove the axis tick marks and tick labels. Set the aspect ratio to obtain square pixels.

```
axis off
axis image
```



### Load and Display JPEG Image File

Load a JPEG image file of the Cat's Eye Nebula from the Hubble Space Telescope (image courtesy NASA). Display the original image using its RGB color values (left) as a subplot.

Create a linked subplot (same size and scale) to display the transformed intensity image as a heat map (right).

figure

# image

---

```
ax(1) = subplot(1,2,1);
rgb = imread('ngc6543a.jpg');
image(rgb);
title('RGB image')

ax(2) = subplot(1,2,2);
im = mean(rgb,3);
image(im);
title('Intensity Heat Map')
colormap(hot(256))
linkaxes(ax,'xy')
axis(ax,'image')
```

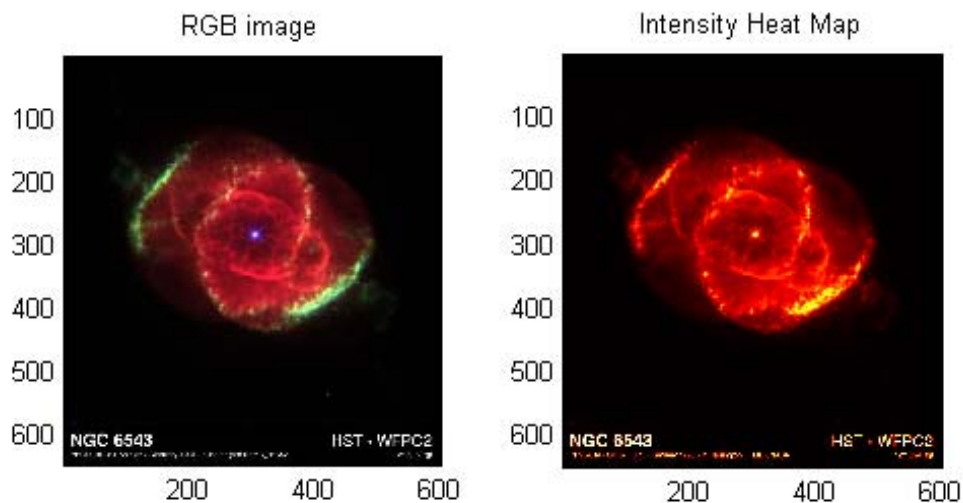

## Setting Default Properties

You can set default image properties on the axes, figure, and root object levels:

```
set(0, 'DefaultImageProperty', PropertyValue...)
set(gcf, 'DefaultImageProperty', PropertyValue...)
set(gca, 'DefaultImageProperty', PropertyValue...)
```

# image

---

where *Property* is the name of the image property and *PropertyValue* is the value you are specifying. Use `set` and `get` to access image properties.

## Tutorials

For more information, see “Working with Images in MATLAB Graphics”  
.

## See Also

`colormap` | `imagesc` | `imfinfo` | `imread` | `imwrite` | `newplot` | `pcolor`  
| `surface` | Image Properties

## Purpose

Define image properties

## Creating Image Objects

Use `image` to create image objects.

## Modifying Properties

You can set and query graphics object properties in two ways:

- “Customize Objects in Graph” is an interactive tool that enables you to see and change object property values.
- The `set` and `get` commands enable you to set and query the values of properties.

To change the default values of properties, see “Setting Default Property Values”.

See “Core Graphics Objects” for general information about this type of object.

## Image Property Descriptions

This section provides a description of properties. Curly braces { } enclose default values.

`AlphaData`

m-by-n matrix of `double` or `uint8`

*Transparency data.* A matrix of non-NaN values specifying the transparency of each face or vertex of the object. The `AlphaData` can be of class `double` or `uint8`.

MATLAB software determines the transparency in one of the following ways:

- Using the elements of `AlphaData` as transparency values (`AlphaDataMapping` set to `none`)
- Using the elements of `AlphaData` as indices into the current `alphamap` (`AlphaDataMapping` set to `direct`)

# Image Properties

---

- Scaling the elements of `AlphaData` to range between the minimum and maximum values of the axes `ALim` property (`AlphaDataMapping` set to `scaled`, the default)

## `AlphaDataMapping`

`none` | `direct` | `{scaled}`

*Transparency mapping method.* Determines how MATLAB interprets indexed alpha data. Values for this property are:

- `none` — The transparency values of `AlphaData` are between 0 and 1 or are clamped to this range.
- `scaled` — Transform the `AlphaData` to span the portion of the `alphamap` indicated by the axes `ALim` property, linearly mapping data values to alpha values (the default).
- `direct` — Use the `AlphaData` as indices directly into the `alphamap`. When not scaled, the data are usually integer values ranging from 1 to `length(alphamap)`. MATLAB maps values less than 1 to the first alpha value in the `alphamap`, and values greater than `length(alphamap)` to the last alpha value in the `alphamap`. Values with a decimal portion are fixed to the nearest, lower integer. If `AlphaData` is an array of `uint8` integers, then the indexing begins at 0 (that is, MATLAB maps a value of 0 to the first alpha value in the `alphamap`).

## `Annotation`

`hg.Annotation` object (read-only)

*Handle of Annotation object.* The `Annotation` property enables you to specify whether this image object is represented in a figure legend.

Querying the `Annotation` property returns the handle of an `hg.Annotation` object. The `hg.Annotation` object has a property called `LegendInformation`, which contains an `hg.LegendEntry` object.



Once you have obtained the `hg.LegendEntry` object, you can set its `IconDisplayStyle` property to control whether the image object is displayed in a figure legend:

| <b>IconDisplayStyle Value</b> | <b>Purpose</b>                                        |
|-------------------------------|-------------------------------------------------------|
| on                            | Represent this image object in a legend (default)     |
| off                           | Do not include this image object in a legend          |
| children                      | Same as on because image objects do not have children |

## Setting the `IconDisplayStyle` property

Set the `IconDisplayStyle` of a graphics object with handle `hobj` to `off`:

```
hAnnotation = get(hobj, 'Annotation');
hLegendEntry = get(hAnnotation, 'LegendInformation');
set(hLegendEntry, 'IconDisplayStyle', 'off')
```

## Using the `IconDisplayStyle` property

See “Control Legend Content” for more information and examples.

`BeingDeleted`  
on | {off} (read-only)

*This object is being deleted.* Mechanism to determine if objects are in the process of being deleted. MATLAB sets the `BeingDeleted` property to `on` when the object’s delete function callback is called (see the `DeleteFcn` property). It remains set to `on` while the delete function executes, after which the object no longer exists.

For example, an object’s delete function calls other functions that act on a number of different objects. If a function does not need to

# Image Properties

---

perform an action on an about-be-deleted object, it can check the object's `BeingDeleted` property before acting.

`BusyAction`  
cancel | {queue}

*Callback queuing*

Determines how MATLAB handles the execution of interrupting callbacks.

A *running* callback is the currently executing callback. The *interrupting* callback is the callback that tries to interrupt the *running* callback. The `BusyAction` property of the *interrupting* callback determines how MATLAB handles its execution. When the `BusyAction` property is set to:

- 'queue' — Puts the *interrupting* callback in a queue to be processed after the *running* callback finishes execution.
- 'cancel' — Discards the *interrupting* callback as MATLAB finishes execution.

For information about how the `Interruptible` property of the callback controls whether other callbacks can interrupt the *running* callback, see the `Interruptible` property description.

`ButtonDownFcn`  
string | function handle

*Button press callback function.* Executes whenever you press a mouse button while the pointer is over this object, but not over another graphics object.

See the figure's `SelectionType` property to determine if modifier keys were also pressed.

This property can be

- A string that is a valid MATLAB expression
- The name of a MATLAB file
- A function handle

Set this property to a function handle that references the callback. The expressions execute in the MATLAB workspace.

For information on the syntax of callback functions, see [Function Handle Callbacks](#).

## CData

matrix | m-by-n-by-3 array

*The image data.* A matrix or 3-D array of values specifying the color of each rectangular area defining the image. `image(C)` assigns the values of `C` to `CData`. MATLAB determines the coloring of the image in one of three ways:

- Using the elements of `CData` as indices into the current colormap (the default) (`CDataMapping` set to `direct`)
- Scaling the elements of `CData` to range between the values `min(get(gca,'CLim'))` and `max(get(gca,'CLim'))` (`CDataMapping` set to `scaled`)
- Interpreting the elements of `CData` directly as RGB values (true color specification)

Note that the behavior of NaNs in image `CData` is not defined. See the image `AlphaData` property for information on using transparency with images.

A true color specification for `CData` requires an m-by-n-by-3 array of RGB values. The first page contains the red component, the second page the green component, and the third page the blue component of each element in the image. RGB values range from 0 to 1. The following picture illustrates the relative dimensions of `CData` for the two color models.

# Image Properties

---

Indexed Colors

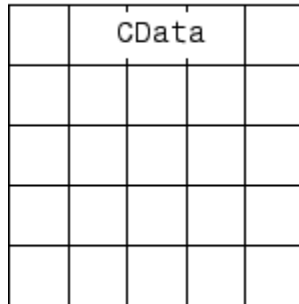

True Colors

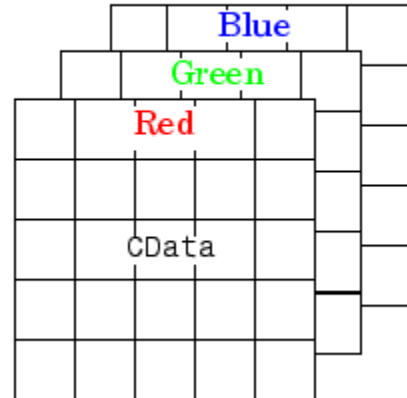

If CData has only one row or column, the height or width respectively is always one data unit and is centered about the first YData or XData element respectively. For example, using a 4-by-1 matrix of random data:

```
C = rand(4,1);
image(C,'CDataMapping','scaled')
axis image
```

produces

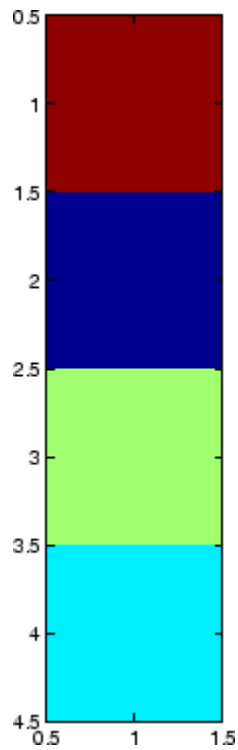

`CDataMapping`  
scaled | {direct}

*Direct or scaled indexed colors.* Determines whether MATLAB interprets the values in `CData` as indices into the figure colormap (the default) or scales the values according to the values of the axes `CLim` property.

When `CDataMapping` is `direct`, the values of `CData` should be in the following ranges:

- In the range 1 to `length(get(gcf, 'Colormap'))` for type `double` or `single`

# Image Properties

---

- In the range 0 to `length(get(gcf, 'Colormap'))` (up to the range limits of the type) for types `uint8` and `uint16`.
- If `CData` is of type `logical`, then the values of 0 index the first color of the colormap and values of 1 index the second color.

If you use true color specification for `CData`, the `CDataMapping` property has no effect.

**Children**  
handle

The empty matrix; image objects have no children.

**Clipping**  
{on} | off

*Clipping mode.* By default, MATLAB clips images to the axes rectangle. If you set `Clipping` to `off`, the image can be displayed outside the axes rectangle. For example, if you create an image, set `hold` to `on`, freeze axis scaling (with `axis manual`), and then create a larger image, it extends beyond the axis limits.

**CreateFcn**  
string | function handle

*Callback routine executed during object creation.* This property defines a callback routine that executes when MATLAB creates an image object. You must define this property as a default value for images or in a call to the `image` function to create a new image object. For example, the statement:

```
set(0, 'DefaultImageCreateFcn', 'axis image')
```

defines a default value on the root level that sets the aspect ratio and the axis limits so the image has square pixels. MATLAB executes this routine after setting all image properties. Setting this property on an existing image object has no effect.

The handle of the object whose `CreateFcn` is being executed is accessible only through the root `CallbackObject` property, which you can query using `gcbo`.

See “Function Handle Callbacks” for information on how to use function handles to define the callback function.

## DeleteFcn

function handle | cell array containing function handle and additional arguments | string (not recommended)

*Callback executed during object deletion.* Executes when this object is deleted (for example, this might happen when you issue a `delete` command on the object, its parent axes, or the figure containing it). MATLAB executes the callback before destroying the object’s properties so the callback routine can query these values. The default is an empty array.

The handle of the object whose `DeleteFcn` is being executed is accessible only through the root `CallbackObject` property, which can be queried using `gcbo`.

For information on the syntax of callback functions, see [Function Handle Callbacks](#).

See the `BeingDeleted` property for related information.

## DisplayName

string

*String used by legend.* The `legend` function uses the `DisplayName` property to label the image object in the legend. The default is an empty string.

- If you specify string arguments with the `legend` function, MATLAB set `DisplayName` to the corresponding string and uses that string for the legend.

# Image Properties

---

- If `DisplayName` is empty, `legend` creates a string of the form, `['data' n]`, where  $n$  is the number assigned to the object based on its location in the list of legend entries. However, `legend` does not set `DisplayName` to this string.
- If you edit the string directly in an existing legend, MATLAB sets `DisplayName` to the edited string.
- If you specify a string for the `DisplayName` property and create the legend using the figure toolbar, then MATLAB uses the string defined by `DisplayName`.
- To add a legend programmatically that uses the `DisplayName` string, call `legend` with the `toggle` or `show` option.

See “Control Legend Content” for more information and examples.

## EraseMode

{normal} | none | xor | background

*Erase mode.* Controls the technique MATLAB uses to draw and erase objects. Use alternative erase modes for creating animated sequences, where control of the way individual objects are redrawn is necessary to improve performance and obtain the desired effect.

- `normal` — Redraw the affected region of the display, performing the three-dimensional analysis necessary to correctly render all objects. This mode produces the most accurate picture, but is the slowest. The other modes are faster, but do not perform a complete redraw and are therefore less accurate.
- `none` — Do not erase the object when it is moved or destroyed. While the object is still visible on the screen after erasing with `EraseMode none`, you cannot print it because MATLAB stores no information about its former location.
- `xor` — Draw and erase the object by performing an exclusive OR (XOR) with the color of the screen beneath it. This mode does not damage the color of the objects beneath it. However,



the object's color depends on the color of whatever is beneath it on the display.

- **background** — Erase the object by redrawing it in the axes background `Color`, or the figure background `Color` if the axes `Color` property is `none`. This damages objects that are behind the erased object, but properly colors the erased object.

Set the axes background color with the axes `Color` property. Set the figure background color with the figure `Color` property.

## Printing with Nonnormal Erase Modes

MATLAB always prints figures as if the `EraseMode` of all objects is `normal`. This means graphics objects created with `EraseMode` set to `none`, `xor`, or `background` can look different on screen than on paper. On screen, MATLAB mathematically combines layers of colors (for example, performing an XOR on a pixel color with that of the pixel behind it) and ignore three-dimensional sorting to obtain greater rendering speed. However, these techniques are not applied to the printed output.

You can use the `getframe` command or other screen capture applications to create an image of a figure containing nonnormal mode objects.

`HandleVisibility`  
{on} | callback | off

*Control access to object's handle.* Determines when an object's handle is visible in its parent's list of children. `HandleVisibility` is useful for preventing command-line users from accidentally accessing objects that you need to protect for some reason.

- **on** — Handles are always visible.
- **callback** — Handles are visible from within callback routines or functions invoked by callback routines, but not from within functions invoked from the command line. This provides

a means to protect GUIs from command-line users, while allowing callback routines to have access to object handles.

- `off` — Handles are invisible at all times. Use this option when a callback invokes a function that could damage the GUI (such as evaluating a user-typed string). This option temporarily hides its own handles during the execution of that function.

## Functions Affected by Handle Visibility

When a handle is not visible in its parent's list of children, it cannot be returned by functions that obtain handles by searching the object hierarchy or querying handle properties. This includes `get`, `findobj`, `gca`, `gcf`, `gco`, `newplot`, `cla`, `clf`, and `close`.

## Properties Affected by Handle Visibility

When a handle's visibility is restricted using `callback` or `off`, the object's handle does not appear in its parent's `Children` property, figures do not appear in the root's `CurrentFigure` property, objects do not appear in the root's `CallbackObject` property or in the figure's `CurrentObject` property, and axes do not appear in their parent's `CurrentAxes` property.

## Overriding Handle Visibility

You can set the root `ShowHiddenHandles` property to `on` to make all handles visible regardless of their `HandleVisibility` settings. This does not affect the values of the `HandleVisibility` properties. See also `findall`.

## Handle Validity

Hidden handles are still valid. If you know an object's handle, you can `set` and `get` its properties and pass it to any function that operates on handles.

---

**Note** If you change one data source property to a variable that contains data of a different dimension, you might cause the function to generate a warning and not render the graph until you have changed all data source properties to appropriate values.

---

## HitTest

{on} | off

*Selectable by mouse click.* Determines whether this object can become the current object (as returned by the `gco` command and the figure `CurrentObject` property) as a result of a mouse click on the objects that compose the area graph. If `HitTest` is `off`, clicking this object selects the object below it (which is usually the axes containing it).

## Interruptible

off | {on}

*Callback routine interruption*

Controls whether MATLAB can interrupt an object's callback function when subsequent callbacks attempt to interrupt it.

For Graphics objects, the `Interruptible` property affects only the callbacks for the `ButtonDownFcn` property. A *running* callback is the currently executing callback. The *interrupting* callback is the callback that tries to interrupt the *running* callback. MATLAB handles both the callbacks based on the `Interruptible` property of the object of the *running* callback.

When the `Interruptible` property is set to:

- 'off', MATLAB finishes execution of the *running* callback without any interruptions
- 'on', these conditions apply:

# Image Properties

---

- If there is a `drawnow`, `figure`, `getframe`, `waitfor`, or `pause` command in the *running* callback, then MATLAB executes the *interrupting* callbacks which are already in the queue and returns to finish execution of the current callback.
- If one of the above functions is not in the *running* callback, then MATLAB finishes execution of the current callback without any interruption.

BusyAction property of the object of interrupting callback determines whether the callback should be ignored or should be put in the queue.

Setting Interruptible property to on (default), allows a callback from other graphics objects to interrupt callback functions originating from this object.

---

**Note** MATLAB does not save the state of properties or the display when an interruption occurs. For example, the handle returned by the `gca` or `gcf` command may be changed as another callback is executed.

---

After the function that interrupts a callback completes, the callback resumes execution where it halted when interrupted. For more information, see “Control Callback Execution and Interruption”.

## Parent

handle of parent axes, `hgroup`, or `hgtransform`

*Parent of object.* Handle of the object’s parent. The parent is normally the axes, `hgroup`, or `hgtransform` object that contains the object.

## Selected

on | {off}

*Object selection state.* When you set this property to on, MATLAB displays selection handles at the corners and midpoints if the `SelectionHighlight` property is also on (the default). You can, for example, define the `ButtonDownFcn` callback to set this property to on, thereby indicating that this particular object is selected. This property is also set to on when an object is manually selected in plot edit mode.

`SelectionHighlight`  
{on} | off

*Object highlighted when selected.*

- on — MATLAB indicates the selected state by drawing four edge handles and four corner handles.
- off — MATLAB does not draw the handles except when in plot edit mode and objects are selected manually.

`Tag`  
string

*User-specified object label.* Provides a means to identify graphics objects with a user-specified label. The default is an empty string.

Use the `Tag` property and the `findobj` function to manipulate specific objects within a plotting hierarchy.

For example, create an `areaseries` object and set the `Tag` property.

```
t = area(Y, 'Tag', 'area1')
```

When you want to access objects of a given type, use `findobj` to find the object's handle. The following statement changes the `FaceColor` property of the object whose `Tag` is `area1`.

```
set(findobj('Tag', 'area1'), 'FaceColor', 'red')
```

`Type`  
string (read-only)

# Image Properties

---

*Type of graphics object.* String that identifies the class of the graphics object. Use this property to find all objects of a given type within a plotting hierarchy. For image objects, `Type` is always `'image'`.

## UIContextMenu

handle of `uicontextmenu` object

*Associate context menu with object.* Handle of a `uicontextmenu` object created in the object's parent figure. Use the `uicontextmenu` function to create the context menu. MATLAB displays the context menu whenever you right-click over the object. The default value is an empty array.

## UserData

array

*User-specified data.* Data you want to associate with this object (including cell arrays and structures). The default value is an empty array. MATLAB does not use this data, but you can access it using the `set` and `get` commands.

## Visible

{on} | off

*Visibility of object and its children.*

- `on` — Object and all children of the object are visible unless the child object's `Visible` property is `off`.
- `off` — Object not displayed. However, the object still exists and you can set and query its properties.

## XData

[1 size(CData,2)] by default

*Control placement of image along x-axis.* A vector specifying the locations of the centers of the elements `CData(1,1)` and `CData(m,n)`, where `CData` has a size of `m`-by-`n`. Element `CData(1,1)` is centered over the coordinate defined by the first

elements in `XData` and `YData`. Element `CData(m,n)` is centered over the coordinate defined by the last elements in `XData` and `YData`. The centers of the remaining elements of `CData` are evenly distributed between those two points.

The width of each `CData` element is determined by the expression:

$$(XData(2) - XData(1)) / (\text{size}(CData, 2) - 1)$$

You can also specify a single value for `XData`. In this case, `image` centers the first element at this coordinate and centers each following element one unit apart.

`YData`

`[ 1 size(CData,1) ]` by default

*Control placement of image along y-axis.* A vector specifying the locations of the centers of the elements `CData(1,1)` and `CData(m,n)`, where `CData` has a size of `m`-by-`n`. Element `CData(1,1)` is centered over the coordinate defined by the first elements in `XData` and `YData`. Element `CData(m,n)` is centered over the coordinate defined by the last elements in `XData` and `YData`. The centers of the remaining elements of `CData` are evenly distributed between those two points.

The height of each `CData` element is determined by the expression:

$$(YData(2) - YData(1)) / (\text{size}(CData, 1) - 1)$$

You can also specify a single value for `YData`. In this case, `image` centers the first element at this coordinate and centers each following element one unit apart.

## See Also

`image`

# imagesc

---

**Purpose** Scale data and display image object

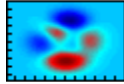

**Syntax**

```
imagesc(C)
imagesc(x,y,C)
imagesc(...,clims)
imagesc('PropertyName',PropertyValue,...)
h = imagesc(...)
```

**Description** The `imagesc` function scales image data to the full range of the current colormap and displays the image. (See “Examples” on page 1-3191 for an illustration.)

`imagesc(C)` displays `C` as an image. Each element of `C` corresponds to a rectangular area in the image. The values of the elements of `C` are indices into the current colormap that determine the color of each patch.

`imagesc(x,y,C)` displays `C` as an image and specifies the bounds of the  $x$ - and  $y$ -axis with vectors `x` and `y`. If `x(1) > x(2)` or `y(1) > y(2)`, the image is flipped left-right or up-down, respectively. If `x` and `y` are scalars, the image is translated to the specified location `(x,y)` such that the upper left corner of the image starts at `(x,y)`.

`imagesc(...,clims)` normalizes the values in `C` to the range specified by `clims` and displays `C` as an image. `clims` is a two-element vector that limits the range of data values in `C`. These values map to the full range of values in the current colormap.

`imagesc('PropertyName',PropertyValue,...)` is the low-level syntax of the `imagesc` function. It specifies only property name/property value pairs as input arguments. See Image Properties for a list of the property names and their values.

`h = imagesc(...)` returns the handle for an image graphics object.



## Tips

$x$  and  $y$  do not affect the elements in  $C$ ; they only affect the annotation of the axes. If  $\text{length}(x) > 2$  or  $\text{length}(y) > 2$ , `imagesc` ignores all except the first and last elements of the respective vector.

`imagesc` creates an image with `CDataMapping` set to `scaled`, and sets the axes `CLim` property to the value passed in `clims`.

You cannot interactively pan or zoom outside the  $x$ -limits or  $y$ -limits of an image.

By default, `imagesc` plots the  $y$ -axis from lowest to highest value, top to bottom. To reverse this, type `set(gca, 'YDir', 'normal')`. This will reverse both the  $y$ -axis and the image.

## Examples

You can expand midrange color resolution by mapping low values to the first color and high values to the last color in the colormap by specifying color value limits (`clims`). If the size of the current colormap is 81-by-3, the statements

```
clims = [10 60]
imagesc(C,clims)
```

map the data values in  $C$  to the colormap as shown in this illustration and the code that follows:

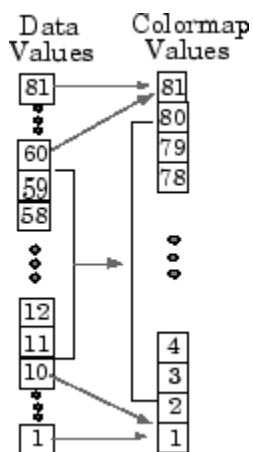

# imagesc

---

In this example, the left image maps to the gray colormap using the statements

```
load clown
figure
subplot(1,2,1)
imagesc(X)
colormap(gray)
axis image
title('Default CLim (= [1 81])')
```

The right image has values between 10 and 60 scaled to the full range of the gray colormap using the statements

```
subplot(1,2,2)
clims = [10 60];
imagesc(X,clims)
colormap(gray)
axis image
title('CLim = [10 60]')
```

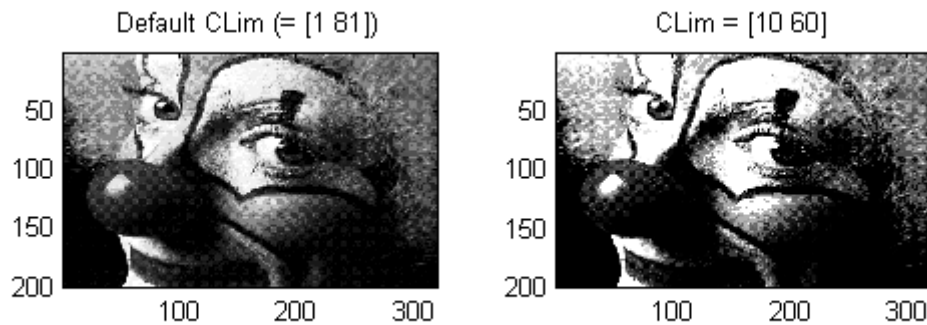

This example shows how to shift the image starting from origin to a position (100, 100),

```
i = imread('eight.tif');
```

```
figure; subplot(2,2,1); imagesc(i);
axis([0 400 0 400]);
colormap(gray);
subplot(2,2,2); imagesc(100,100,i);
axis([0 400 0 400]);
colormap(gray);
```

The figure output is as:

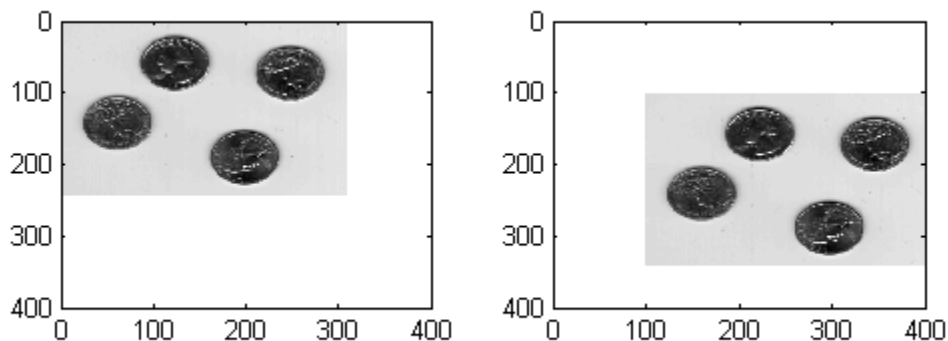

The top right corner of the image is now starting from (100,100) instead of the origin.

Passing vector values with the image scales the image to the specified size of 400-by-400.

```
figure; imagesc(1:400,1:400,i);
colormap(gray);
```

# imagesc

---



## See Also

`image` | `imfinfo` | `imread` | `imwrite` | `colorbar` | `colormap` | `pcolor`  
| `surface` | `surf`

**Purpose** Approximate indexed image by reducing number of colors

**Syntax**

```
[Y,newmap] = imapprox(X,map,n)
[Y,newmap] = imapprox(X,map,tol)
Y = imapprox(X,map,newmap)
Y = imapprox(...,dither_option)
```

**Description** [Y,newmap] = imapprox(X,map,n) approximates the colors in the indexed image X and associated colormap map by using minimum variance quantization. imapprox returns the indexed image Y with colormap newmap, which has at most n colors.

[Y,newmap] = imapprox(X,map,tol) approximates the colors in X and map through uniform quantization. newmap contains at most  $(\text{floor}(1/\text{tol})+1)^3$  colors. tol must be between 0 and 1.0.

Y = imapprox(X,map,newmap) approximates the colors in map by using colormap mapping to find the colors in newmap that best match the colors in map.

Y = imapprox(...,dither\_option) enables or disables dithering. dither\_option is a string that can have one of these values.

| Value               | Description                                                                                           |
|---------------------|-------------------------------------------------------------------------------------------------------|
| {'dither'}(default) | Dithers, if necessary, to achieve better color resolution at the expense of spatial resolution.       |
| 'nodither'          | Maps each color in the original image to the closest color in the new map. No dithering is performed. |

**Class Support** The input image X can be of class uint8, uint16, or double. The output image Y is of class uint8 if the length of newmap is less than or equal to 256. If the length of newmap is greater than 256, Y is of class double.

**Algorithms** imapprox uses rgb2ind to create a new colormap that uses fewer colors.

## Examples

Load an indexed image of a mandrill's face. Display image  $X$  using its associated colormap,  $map$ , which has 220 colors.

```
load mandrill
figure('color','k')
image(X)
colormap(map)
size(map) % See that the color map has 220 entries

ans =
 220 3

axis off % Remove axis ticks and numbers
axis image % Set aspect ratio to obtain square pixels
```



Reduce the number of colors in the indexed image from 220 to only 16 colors by producing a new image, `Y`, and its associated colormap, `newmap`:

```
figure('color','k')
[Y, newmap] = imapprox(X, map, 16);
size(newmap) % See that the new color map has 16 entries
```

```
ans =
 16 3
```

# imapprox

---

```
image(Y)
colormap(newmap)
axis off % Remove axis ticks and numbers
axis image % Set aspect ratio to obtain square pixels
```



## See Also

[cmunique](#) | [dither](#) | [rgb2ind](#)



**Purpose**

Information about graphics file

**Syntax**

```
info = imfinfo(filename)
info = imfinfo(filename,fmt)
info = imfinfo(URL)
```

**Description**

`info = imfinfo(filename)` returns a structure whose fields contain information about an image in a graphics file, `filename`. The file must be in the current folder or in a folder on the MATLAB path.

The format of the file is inferred from its contents.

- If `filename` is a TIFF, HDF, ICO, GIF, or CUR file containing more than one image, then `info` is a structure array with one element for each image in the file. For example, `info(3)` would contain information about the third image in the file.

`info = imfinfo(filename,fmt)` additionally looks for a file named `filename.fmt`, if MATLAB cannot find a file named `filename`.

`info = imfinfo(URL)` returns information about the image at the specified Internet resource, `URL`.

**Input Arguments****filename - Name of graphics file**

string

Name of graphics file, specified as a string.

**Example:** 'myImage.jpg'

**Data Types**

char

**fmt - Image format**

string

# imfinfo

---

Image format, specified as a string. The possible values for `fmt` are contained in the MATLAB file format registry. To view of list of these formats, run the `imformats` command.

**Example:** `'gif'`

## Data Types

`char`

## URL - Image location

`string`

Image location, specified as a string. URL must include the protocol type (e.g., `http://`).

## Data Types

`char`

## Output Arguments

## `info` - Information about graphics file

`structure array`

Information about the graphics file, returned as a structure array. The set of fields in `info` depends on the individual file and its format. This table lists the nine fields that always appear, and describes their values.

| Field Name  | Description                                                                                                                                   | Value   |
|-------------|-----------------------------------------------------------------------------------------------------------------------------------------------|---------|
| Filename    | Name of the file or the Internet URL specified. If the file is not in the current folder, the string contains the full path name of the file. | string  |
| FileModDate | Date when the file was last modified.                                                                                                         | string  |
| FileSize    | Size of the file, in bytes.                                                                                                                   | integer |

| Field Name    | Description                                                                                                                                                                                           | Value            |
|---------------|-------------------------------------------------------------------------------------------------------------------------------------------------------------------------------------------------------|------------------|
| Format        | File format, as specified by <i>fmt</i> . For formats with more than one possible extension (for example, JPEG and TIFF files), <i>imfinfo</i> returns the first variant in the file format registry. | string           |
| FormatVersion | File format version.                                                                                                                                                                                  | string or number |
| Width         | Image width, in pixels.                                                                                                                                                                               | integer          |
| Height        | Image height, in pixels.                                                                                                                                                                              | integer          |
| BitDepth      | Number of bits per pixel.                                                                                                                                                                             | integer          |
| ColorType     | Image type. <i>ColorType</i> includes, but is not limited to, 'truecolor' for a truecolor (RGB) image, 'grayscale' for a grayscale intensity image, or 'indexed' for an indexed image.                | string           |

Additional fields returned by some file formats:

- **JPEG and TIFF only** — If *filename* contains Exchangeable Image File Format (EXIF) tags, then *info* might also contain 'DigitalCamera' or 'GPSInfo' (global positioning system information) fields.
- **GIF only** — *imfinfo* returns the value of the 'DelayTime' field in hundredths of seconds.
- **JPEG2000 only** — The *info* structure contains an m-by-3 cell array, 'ChannelDefinition'. The first column of 'ChannelDefinition' reports a channel position as it exists in the file. The second column reports the type of channel, and the third column reports the channel mapping.

## Examples

### Return Information About Graphics File

Find information about the example image, `ngc6543a.jpg`.

```
info = imfinfo('ngc6543a.jpg')
```

```
info =
```

```
 Filename: 'matlabroot\toolbox\matlab\demos\ngc6543a.jpg'
 FileModDate: '01-Oct-1996 16:19:44'
 FileSize: 27387
 Format: 'jpg'
 FormatVersion: ''
 Width: 600
 Height: 650
 BitDepth: 24
 ColorType: 'truecolor'
 FormatSignature: ''
 NumberOfSamples: 3
 CodingMethod: 'Huffman'
 CodingProcess: 'Sequential'
 Comment: {'CREATOR: XV Version 3.00b Rev: 6/15/94 Quality ='
 '}'
```

## See Also

[imformats](#) | [imread](#) | [imwrite](#)

**Purpose** Manage image file format registry

**Syntax** `imformats`

```
formatStruct = imformats(fmt)

registry = imformats
registry = imformats(formatStruct)
registry = imformats('add',formatStruct)
registry = imformats('remove',fmt)
registry = imformats('update',fmt,formatStruct)
registry = imformats('factory')
```

**Description** `imformats` displays a table of information listing all the values in the MATLAB file format registry. This registry determines which file formats the `iminfo`, `imread`, and `imwrite` functions support.

`formatStruct = imformats(fmt)` searches the known formats in the MATLAB file format registry for the format associated with the file name extension specified by `fmt`. If found, `formatStruct` is a structure containing the characteristics and function names associated with the format. Otherwise, `formatStruct` is an empty structure.

`registry = imformats` returns a structure array, `registry`, containing all the values in the MATLAB file format registry.

`registry = imformats(formatStruct)` sets the MATLAB file format registry for the current MATLAB session to the values in `formatStruct`. The output structure, `registry`, contains the new registry settings. Use this syntax to replace image file format support.

Incorrect use of `imformats` to specify values in the MATLAB file format registry can result in the inability to load any image files. To return the file format registry to a working state, use `imformats` with the `'factory'` input.

# imformats

---

`registry = imformats('add',formatStruct)` adds the values in `formatStruct` to the file format registry. Use this syntax to add image file format support.

`registry = imformats('remove',fmt)` removes the format with the extension specified by `fmt` from the file format registry. Use this syntax to remove image file format support.

`registry = imformats('update',fmt,formatStruct)` changes the format registry values for the format with extension `fmt` to have the values specified by `formatStruct`.

`registry = imformats('factory')` resets the MATLAB file format registry to the default format registry values. This removes any user-specified settings.

## Input Arguments

### **formatStruct** - File format registry values

structure array

File format registry values, specified as a structure array with the following 7 fields.

| Field             | Description                                                            | Value                     |
|-------------------|------------------------------------------------------------------------|---------------------------|
| <code>ext</code>  | File name extensions that are valid for this format.                   | Cell array of strings     |
| <code>isa</code>  | Name of the function that determines if a file is of a certain format. | String or function handle |
| <code>info</code> | Name of the function that reads information about a file.              | String or function handle |
| <code>read</code> | Name of the function that reads image data in a file.                  | String or function handle |

| Field       | Description                                             | Value                                                    |
|-------------|---------------------------------------------------------|----------------------------------------------------------|
| write       | Name of the function that writes MATLAB data to a file. | String or function handle                                |
| alpha       | Presence or absence of an alpha channel.                | 1 if the format has an alpha channel; otherwise it is 0. |
| description | Text description of the file format.                    | String                                                   |

The values for the `isa`, `info`, `read`, and `write` fields must be either functions on the MATLAB search path or function handles.

**Data Types**

struct

**fmt - File format extension**

string

File format extension, specified as a string.

**Example:** 'jpg'

**Data Types**

char

**Output Arguments**

**registry - File format registry**

structure array

File format registry, returned as a structure array with the following fields.

# imformats

---

| Field       | Description                                                            | Value                                                    |
|-------------|------------------------------------------------------------------------|----------------------------------------------------------|
| ext         | File name extensions that are valid for this format.                   | Cell array of strings                                    |
| isa         | Name of the function that determines if a file is of a certain format. | String or function handle                                |
| info        | Name of the function that reads information about a file.              | String or function handle                                |
| read        | Name of the function that reads image data in a file.                  | String or function handle                                |
| write       | Name of the function that writes MATLAB data to a file.                | String or function handle                                |
| alpha       | Presence or absence of an alpha channel.                               | 1 if the format has an alpha channel; otherwise it is 0. |
| description | Text description of the file format.                                   | String                                                   |

---

**Note** Use the `imread`, `imwrite`, and `imfinfo` functions to read, write, or get information about an image file when the file format is in the format registry. Do not directly invoke the functions returned in the fields of the registry structure array.

---

## Examples

### Determine if File Format Exists in Registry

Determine if the file format associated with the `.bmp` file extension is in the image file format registry.



```
formatStruct = imformats('bmp')

formatStruct =
 ext: {'bmp'}
 isa: @isbmp
 info: @imbmpinfo
 read: @readbmp
 write: @writebmp
 alpha: 0
 description: 'Windows Bitmap'
```

`formatStruct` is a non empty structure, so the BMP file format is in the registry.

### **Add, Update, or Remove File Format from Registry**

Add a hypothetical file format, ABC, to the image file format registry. Update, and then remove the format.

Create a structure with seven fields, defining values for the new format.

```
formatStruct = struct('ext','abc','isa',@isabc,...
 'info',@abcinfo,'read',@readabc,'write','',...
 'alpha',0,'description','My ABC Format')

formatStruct =
 ext: 'abc'
 isa: @isabc
 info: @abcinfo
 read: @readabc
 write: ''
 alpha: 0
 description: 'My ABC Format'
```

`formatStruct` is a 1-by-1 structure with seven fields. In this example, the write field is empty.

# imformats

---

Add the new format to the file format registry.

```
registry = imformats('add',formatStruct);
```

Redefine the format associated with the extension, `abc`, by adding a value for the `write` field. Then, update the registry value for the format.

```
formatStruct2 = struct('ext','abc','isa',@isabc,...
'info',@abcinfo,'read',@readabc,'write',@writeabc,...
'alpha',0,'description','My ABC Format');
```

```
registry = imformats('update','abc',formatStruct2);
```

Remove the format with the extension, `abc`, from the file format registry.

```
registry = imformats('remove','abc');
```

## Tips

- Changes to the format registry do not persist between MATLAB sessions. To have a format always available when you start MATLAB, add the appropriate `imformats` command to the MATLAB startup file, `startup.m`, located in `$MATLAB/toolbox/local` on UNIX systems, or `$MATLAB\toolbox\local` on Windows systems.

## See Also

`imfinfo` | `imread` | `imwrite` | `path`

## Concepts

- “What Is the MATLAB Search Path?”

**Purpose** Add package or class to current import list

**Syntax**

```
import package_name.class_name
import package_name.function_name
import package_name.*
import package_name.class_name1 package_name.class_name2...
import package_name1.* package_name2.*...
L = import
import
```

**Description** `import package_name.class_name` adds the fully qualified class name to the current import list.

`import package_name.function_name` adds the specified package-based function.

`import package_name.*` adds the specified package name. Note that `package_name` must be followed by `.*`.

`import package_name.class_name1 package_name.class_name2...` adds multiple fully qualified class names.

`import package_name1.* package_name2.*...` adds multiple package names.

`L = import` with no input arguments returns a cell array of strings containing the current import list, without adding to it.

`import` with no input arguments displays the current import list, without adding to it.

The `import` function allows your code to refer to an imported class or function using fewer or no package prefixes.

The `import` function only affects the import list of the function within which it is used. When invoked at the command prompt, `import` uses the import list for the MATLAB command environment. If `import` is used in a script invoked from a function, it affects the import list of the function. If `import` is used in a script that is invoked from the command prompt, it affects the import list for the command environment.

# import

---

The `import` list of a function is persistent across calls to that function and is only cleared when the function is cleared.

To clear the current import list, use the following command.

```
clear import
```

This command may only be invoked at the command prompt. Attempting to use `clear import` within a function results in an error.

## Importing MATLAB Packages and Classes

You can `import` packages and classes into a MATLAB workspace (from the command line or in a function definition). For example:

```
import packagename.*
```

`import` imports all classes and package functions so that you can reference those classes and functions by their simple names, without the package qualifier.

You can `import` just a single class from a package:

```
import packagename.ClassName
import Classname
```

You must still use the class name to call static methods:

```
ClassName.staticMethod()
```

For more information on how `import` works with MATLAB classes and packages, see “Importing Classes”.

## Tips

The `import` function allows your code to refer to an imported class by class name only, rather than with the fully qualified class name. `import` is particularly useful in streamlining calls to constructors, where most references to Java classes occur.

If you use the `import` function in a control statement, for example, `if` or `switch`, or in a function, MATLAB limits the scope of the variables

to that block of code. If you use the variables outside the function or control block, MATLAB displays an error message.

## Limitations

- `import` cannot load a Java JAR package created by the MATLAB Builder™ JA product.

## Examples

To add the `containers.Map` class to the current import list:

```
import containers.Map
myMap = Map('KeyType', 'char', 'ValueType', 'double');
```

---

To import two Java packages:

```
import java.util.Enumeration java.lang.String
s = String('hello'); % Create java.lang.String object
methods Enumeration % List java.util.Enumeration methods
```

---

To add the `java.awt` package:

```
import java.awt.*
f = Frame; % Create java.awt.Frame object
```

---

This example uses `import` in a function to call members of a .NET class in the `System.Drawing` namespace. Create the `getPrinterInfo` function:

```
function ptr = getPrinterInfo
import System.Drawing.Printing.*;
ptr = PrinterSettings;
end
```

To call the function, type:

```
NET.addAssembly('System.Drawing');
```

# import

---

```
printer = getPrinterInfo;
```

## **See Also**

`clear` | `load` | `importdata`

## Purpose

Load data from file

## Syntax

```
A = importdata(filename)
A = importdata('-pastespecial')
A = importdata(___,delimiterIn)
A = importdata(___,delimiterIn,headerlinesIn)
[A,delimiterOut,headerlinesOut] = importdata(___)
```

## Description

`A = importdata(filename)` loads data into array `A`.

`A = importdata('-pastespecial')` loads data from the system clipboard rather than from a file.

`A = importdata(___,delimiterIn)` interprets `delimiterIn` as the column separator in ASCII file, `filename`, or the clipboard data. You can use `delimiterIn` with any of the input arguments in the above syntaxes.

`A = importdata(___,delimiterIn,headerlinesIn)` loads data from ASCII file, `filename`, or the clipboard, reading numeric data starting from line `headerlinesIn+1`.

`[A,delimiterOut,headerlinesOut] = importdata(___)` additionally returns the detected delimiter character for the input ASCII file in `delimiterOut` and the detected number of header lines in `headerlinesOut`, using any of the input arguments in the previous syntaxes.

## Input Arguments

### **filename** - Name and extension of file to import

string

Name and extension of the file to import, specified as a string. If `importdata` recognizes the file extension, it calls the MATLAB helper function designed to import the associated file format (such as `load`

# importdata

---

for MAT-files or `xlsread` for spreadsheets). Otherwise, `importdata` interprets the file as a delimited ASCII file.

For ASCII files and spreadsheets, `importdata` expects to find numeric data in a rectangular form (that is, like a matrix). Text headers can appear above or to the left of the numeric data, as follows:

- Column headers or file description text at the top of the file, above the numeric data.
- Row headers to the left of the numeric data.

**Example:** `'myFile.jpg'`

## Data Types

char

## **delimiterIn - Column separator character**

string

Column separator character, specified as a string. The default character is interpreted from the file. Use `'\t'` for tab.

**Example:** `','`

**Example:** `' '`

## Data Types

char

## **headerlinesIn - Number of text header lines in ASCII file**

nonnegative scalar integer

Number of text header lines in the ASCII file, specified as a nonnegative scalar integer. If you do not specify `headerlinesIn`, the `importdata` function detects this value in the file.

## Data Types

single | double | int8 | int16 | int32 | int64 | uint8 |  
uint16 | uint32 | uint64



## Output Arguments

### A - Data from the file

matrix | multidimensional array | scalar structure array

Data from the file, returned as a matrix, multidimensional array, or scalar structure array, depending on the characteristics of the file. Based on the file format of the input file, `importdata` calls a helper function to read the data. When the helper function returns more than one nonempty output, `importdata` combines the outputs into a struct array.

This table lists the file formats associated with helper functions that can return more than one output, and the possible fields in the structure array, `A`.

| File Format                  | Possible Fields                                                                                  | Class                                                                                                                                                                                                                                              |
|------------------------------|--------------------------------------------------------------------------------------------------|----------------------------------------------------------------------------------------------------------------------------------------------------------------------------------------------------------------------------------------------------|
| MAT-files                    | One field for each variable                                                                      | Associated with each variable.                                                                                                                                                                                                                     |
| ASCII files and Spreadsheets | <code>data</code><br><code>textdata</code><br><code>colheaders</code><br><code>rowheaders</code> | For ASCII files, <code>data</code> contains a double array. Other fields contain cell arrays of strings. <code>textdata</code> includes row and column headers. For spreadsheets, each field contains a struct, with one field for each worksheet. |
| Images                       | <code>cdata</code><br><code>colormap</code><br><code>alpha</code>                                | See <code>imread</code> .                                                                                                                                                                                                                          |
| Audio files                  | <code>data</code><br><code>fs</code>                                                             | See <code>audioread</code> .                                                                                                                                                                                                                       |

The MATLAB helper functions for most other supported file formats return one output. For more information about the class of each output,

see the functions listed in “Supported File Formats for Import and Export”.

If the ASCII file or spreadsheet contains either column or row headers, but not both, `importdata` returns a `colheaders` or `rowheaders` field in the output structure, where:

- `colheaders` contains only the last line of column header text. `importdata` stores all text in the `textdata` field.
- `rowheaders` is created only when the file or worksheet contains a single column of row headers.

### **delimiterOut - Detected column separator in the input ASCII file**

string

Detected column separator in the input ASCII file, returned as a string.

### **headerlinesOut - Detected number of text header lines in the input ASCII file**

integer

Detected number of text header lines in the input ASCII file, returned as an integer.

## **Examples**

### **Import and Display an Image**

Import and display the image `ngc6543a.jpg`.

```
A = importdata('ngc6543a.jpg');
image(A);
```

The output, `A`, is class `uint8` because the helper function, `imread`, returns empty results for `colormap` and `alpha`.

### **Import a Text File and Specify Delimiter and Column Header**

Using a text editor, create a space-delimited ASCII file with column headers called `myfile01.txt`.

```
Day1 Day2 Day3 Day4 Day5 Day6 Day7
```

```
95.01 76.21 61.54 40.57 5.79 20.28 1.53
23.11 45.65 79.19 93.55 35.29 19.87 74.68
60.68 1.85 92.18 91.69 81.32 60.38 44.51
48.60 82.14 73.82 41.03 0.99 27.22 93.18
89.13 44.47 17.63 89.36 13.89 19.88 46.60
```

Import the file, specifying the space delimiter and the single column header.

```
filename = 'myfile01.txt';
delimiterIn = ' ';
headerlinesIn = 1;
A = importdata(filename,delimiterIn,headerlinesIn);
```

View columns 3 and 5.

```
for k = [3, 5]
 disp(A.colheaders{1, k})
 disp(A.data(:, k))
 disp(' ')
end
```

```
Day3
 61.5400
 79.1900
 92.1800
 73.8200
 17.6300
```

```
Day5
 5.7900
 35.2900
 81.3200
 0.9900
 13.8900
```

## Import a Text File and Return Detected Delimiter

Using a text editor, create a comma-delimited ASCII file called `myfile02.txt`.

```
1,2,3
4,5,6
7,8,9
```

Import the file, and display the output data and detected delimiter character.

```
filename = 'myfile02.txt';
[A,delimiterOut]=importdata(filename)
```

```
A =
```

```
 1 2 3
 4 5 6
 7 8 9
```

```
delimiterOut =
```

```
,
```

## Import Data from Clipboard

Copy the following lines to the clipboard. Select the text, right-click, and then select **Copy**.

```
1,2,3
4,5,6
7,8,9
```

Import the clipboard data into MATLAB by typing the following.

```
A = importdata('-pastespecial')
```

A =

|   |   |   |
|---|---|---|
| 1 | 2 | 3 |
| 4 | 5 | 6 |
| 7 | 8 | 9 |

## Tips

- To import ASCII files with nonnumeric characters outside of column or row headers, including columns of character data or formatted dates or times, use `textscan` instead of `importdata`.

## See Also

`load` | `save` | `textscan` | `xlsread` | `imread` | `readtable` | `uiimport`

## Concepts

- “Supported File Formats for Import and Export”
- “Ways to Import Text Files”
- “Ways to Import Spreadsheets”
- “Import or Export a Sequence of Files”

# imread

---

**Purpose** Read image from graphics file

**Syntax**

```
A = imread(filename, fmt)
[X, map] = imread(...)
[...] = imread(filename)
[...] = imread(URL,...)
[...] = imread(...,Param1,Val1,Param2,Val2...)
```

**Description** `A = imread(filename, fmt)` reads a grayscale or color image from the file specified by the string `filename`. If the file is not in the current folder, or in a folder on the MATLAB path, specify the full pathname.

The text string `fmt` specifies the format of the file by its standard file extension. For example, specify 'gif' for Graphics Interchange Format files. To see a list of supported formats, with their file extensions, use the `imformats` function. If `imread` cannot find a file named `filename`, it looks for a file named `filename.fmt`.

The return value `A` is an array containing the image data. If the file contains a grayscale image, `A` is an M-by-N array. If the file contains a truecolor image, `A` is an M-by-N-by-3 array. For TIFF files containing color images that use the CMYK color space, `A` is an M-by-N-by-4 array. See TIFF in the Format-Specific Information section for more information.

The class of `A` depends on the bits-per-sample of the image data, rounded to the next byte boundary. For example, `imread` returns 24-bit color data as an array of `uint8` data because the sample size for each color component is 8 bits. See “Tips” on page 1-3221 for a discussion of bitdepths, and see “Format-Specific Information” on page 1-3221 for more detail about supported bit depths and sample sizes for a particular format.

`[X, map] = imread(...)` reads the indexed image in `filename` into `X` and its associated colormap into `map`. Colormap values in the image file are automatically rescaled into the range `[0,1]`.

`[...] = imread(filename)` attempts to infer the format of the file from its content.

[...] = imread(URL,...) reads the image from an Internet URL. The URL must include the protocol type (e.g., http://).

[...] = imread(...,Param1,Val1,Param2,Val2...) specifies parameters that control various characteristics of the operations for specific formats. For more information, see “Format-Specific Information” on page 1-3221.

## Tips

- Bit depth is the number of bits used to represent each image pixel. Bit depth is calculated by multiplying the bits-per-sample with the samples-per-pixel. Thus, a format that uses 8-bits for each color component (or sample) and three samples per pixel has a bit depth of 24. Sometimes the sample size associated with a bit depth can be ambiguous: does a 48-bit bit depth represent six 8-bit samples, four 12-bit samples, or three 16-bit samples? See “Format-Specific Information” on page 1-3221 for sample size information to avoid this ambiguity.

**Format-Specific Information** The following sections provide information about the support for specific formats, listed in alphabetical order by format name. These sections include information about format-specific syntaxes, if they exist.

|                                                    |                                                                    |                                                  |
|----------------------------------------------------|--------------------------------------------------------------------|--------------------------------------------------|
| “BMP — Windows Bitmap” on page 1-3222              | “JPEG — Joint Photographic Experts Group” on page 1-3224           | “PNG — Portable Network Graphics” on page 1-3227 |
| “CUR — Cursor File” on page 1-3222                 | “JPEG 2000 — Joint Photographic Experts Group 2000” on page 1-3225 | “PPM — Portable Pixmap” on page 1-3228           |
| “GIF — Graphics Interchange Format” on page 1-3223 | “PBM — Portable Bitmap” on page 1-3226                             | “RAS — Sun Raster” on page 1-3229                |

|                                                  |                                           |                                                  |
|--------------------------------------------------|-------------------------------------------|--------------------------------------------------|
| “HDF4 — Hierarchical Data Format” on page 1-3224 | “PCX — Windows Paintbrush” on page 1-3227 | “TIFF — Tagged Image File Format” on page 1-3229 |
| “ICO — Icon File” on page 1-3224                 | “PGM — Portable Graymap” on page 1-3227   | “XWD — X Window Dump” on page 1-3231             |

## BMP — Windows Bitmap

| Supported Bitdepths | No Compression | RLE Compression | Output Class | Notes                            |
|---------------------|----------------|-----------------|--------------|----------------------------------|
| 1-bit               | y              | —               | logical      |                                  |
| 4-bit               | y              | y               | uint8        |                                  |
| 8-bit               | y              | y               | uint8        |                                  |
| 16-bit              | y              | —               | uint8        | 1 sample/pixel                   |
| 24-bit              | y              | —               | uint8        | 3 samples/pixel                  |
| 32-bit              | y              | —               | uint8        | 3 samples/pixel (1 byte padding) |

## CUR — Cursor File

| Supported Bitdepths | No Compression | Compression | Output Class |
|---------------------|----------------|-------------|--------------|
| 1-bit               | y              | —           | logical      |
| 4-bit               | y              | —           | uint8        |
| 8-bit               | y              | —           | uint8        |

Format-specific syntaxes:

`[...] = imread(..., idx)` reads in one image from a multi-image icon or cursor file. `idx` is an integer value that specifies the order that the image appears in the file. For example, if `idx` is 3, `imread` reads



the third image in the file. If you omit this argument, `imread` reads the first image in the file.

`[A, map, alpha] = imread(...)` returns the AND mask for the resource, which can be used to determine the transparency information. For cursor files, this mask may contain the only useful data.

---

**Note** By default, Microsoft Windows cursors are 32-by-32 pixels. MATLAB pointers must be 16-by-16. You will probably need to scale your image. If you have Image Processing Toolbox™, you can use its `imresize` function.

---

## GIF – Graphics Interchange Format

| Supported Bitdepths | Output Class |
|---------------------|--------------|
| 1-bit               | logical      |
| 2-bit to 8-bit      | uint8        |

Format-specific syntaxes:

`[...] = imread(..., idx)` reads in one or more frames from a multiframe (i.e., animated) GIF file. `idx` must be an integer scalar or vector of integer values. For example, if `idx` is 3, `imread` reads the third image in the file. If `idx` is 1:5, `imread` returns only the first five frames.

`[...] = imread(..., 'frames', idx)` is the same as the syntax above except that `idx` can be 'all'. In this case, all the frames are read and returned in the order that they appear in the file.

---

**Note** Because of the way that GIF files are structured, all the frames must be read when a particular frame is requested. Consequently, it is much faster to specify a vector of frames or 'all' for `idx` than to call `imread` in a loop when reading multiple frames from the same GIF file.

---

## HDF4 – Hierarchical Data Format

| Supported Bitdepths | Raster Image with colormap | Raster image without colormap | Output Class | Notes           |
|---------------------|----------------------------|-------------------------------|--------------|-----------------|
| 8-bit               | y                          | y                             | uint8        |                 |
| 24-bit              | –                          | y                             | uint8        | 3 samples/pixel |

Format-specific syntaxes:

`[...] = imread(..., ref)` reads in one image from a multi-image HDF4 file. `ref` is an integer value that specifies the reference number used to identify the image. For example, if `ref` is 12, `imread` reads the image whose reference number is 12. (Note that in an HDF4 file the reference numbers do not necessarily correspond to the order of the images in the file. You can use `imfinfo` to match image order with reference number.) If you omit this argument, `imread` reads the first image in the file.

## ICO – Icon File

See “CUR — Cursor File” on page 1-3222

## JPEG – Joint Photographic Experts Group

`imread` can read any baseline JPEG image as well as JPEG images with some commonly used extensions. For information about support for JPEG 2000 files, see JPEG 2000.

| Supported Bits-per-sample | Lossy Compression | Lossless Compression | Output Class | Notes            |
|---------------------------|-------------------|----------------------|--------------|------------------|
| 8-bit                     | y                 | y                    | uint8        | Grayscale or RGB |
| 12-bit                    | y                 | y                    | uint16       | Grayscale or RGB |
| 16-bit                    | –                 | y                    | uint16       | Grayscale        |

### JPEG 2000 – Joint Photographic Experts Group 2000

For information about JPEG files, see JPEG.

**Note** Indexed JPEG 2000 images are not supported. Only JP2 compatible color spaces are supported for JP2/JPX files. By default, all image channels are returned in the order they are stored in the file.

| Supported Bits-per-sample | Lossy Compression | Lossless Compression | Output Class    | Notes            |
|---------------------------|-------------------|----------------------|-----------------|------------------|
| 1-bit                     | y                 | y                    | logical         | Grayscale only   |
| 2- to 8-bit               | y                 | y                    | uint8 or int8   | Grayscale or RGB |
| 9- to 16-bit              | y                 | y                    | uint16 or int16 | Grayscale or RGB |

Format-specific syntaxes:

[...] = imread(..., 'Param1', value1, 'Param2', value2, ...) uses parameter-value pairs to control the read operation, described in the following table.

# imread

| Parameter        | Value                                                                                                                                                                                                                                                                                                                                                                                                             |
|------------------|-------------------------------------------------------------------------------------------------------------------------------------------------------------------------------------------------------------------------------------------------------------------------------------------------------------------------------------------------------------------------------------------------------------------|
| 'ReductionLevel' | A non-negative integer specifying the reduction in the resolution of the image. For a reduction level $L$ , the image resolution is reduced by a factor of $2^L$ . Its default value is 0 implying no reduction. The reduction level is limited by the total number of decomposition levels as specified by the 'WaveletDecompositionLevels' field in the structure returned by the <code>iminfo</code> function. |
| 'PixelRegion'    | {ROWS, COLS} — The <code>imread</code> function returns the sub-image specified by the boundaries in ROWS and COLS. ROWS and COLS must both be two-element vectors that denote the 1-based indices [START STOP]. If 'ReductionLevel' is greater than 0, then ROWS and COLS are coordinates in the reduced-sized image.                                                                                            |
| 'V79Compatible'  | A logical value. If true, the image returned is transformed to grayscale or RGB, consistent with previous versions of <code>imread</code> (MATLAB 7.9 [R2009b] and earlier). Use this option to transform YCC images into RGB. The default is false.                                                                                                                                                              |

## PBM — Portable Bitmap

| Supported Bitdepths | Raw Binary | ASCII (Plain) Encoded | Output Class |
|---------------------|------------|-----------------------|--------------|
| 1-bit               | y          | y                     | logical      |

**PCX – Windows Paintbrush**

| Supported Bitdepths | Output Class | Notes                            |
|---------------------|--------------|----------------------------------|
| 1-bit               | logical      | Grayscale only                   |
| 8-bit               | uint8        | Grayscale or indexed             |
| 24-bit              | uint8        | RGB<br>Three 8-bit samples/pixel |

**PGM – Portable Graymap**

| Supported Bitdepths | Raw Binary | ASCII (Plain) Encoded | Output Class                                     | Notes             |
|---------------------|------------|-----------------------|--------------------------------------------------|-------------------|
| 8-bit               | y          | –                     | uint8                                            |                   |
| 16-bit              | y          | –                     | uint16                                           |                   |
| Arbitrary           | –          | y                     | 1-bit to 8-bit: uint8<br>9-bit to 16-bit: uint16 | Values are scaled |

**PNG – Portable Network Graphics**

| Supported Bitdepths | Output Class | Notes                |
|---------------------|--------------|----------------------|
| 1-bit               | logical      | Grayscale            |
| 2-bit               | uint8        | Grayscale            |
| 4-bit               | uint8        | Grayscale            |
| 8-bit               | uint8        | Grayscale or Indexed |
| 16-bit              | uint16       | Grayscale or Indexed |

| Supported Bitdepths | Output Class | Notes                              |
|---------------------|--------------|------------------------------------|
| 24-bit              | uint8        | RGB<br>Three 8-bit samples/pixel.  |
| 48-bit              | uint16       | RGB<br>Three 16-bit samples/pixel. |

Format-specific syntaxes:

`[...] = imread(..., 'BackgroundColor', BG)` composites any transparent pixels in the input image against the color specified in BG. If BG is 'none', then no compositing is performed. If the input image is indexed, BG must be an integer in the range `[1, P]` where P is the colormap length. If the input image is grayscale, BG should be an integer in the range `[0, 1]`. If the input image is RGB, BG should be a three-element vector whose values are in the range `[0, 1]`. The string 'BackgroundColor' can be abbreviated.

`[A, map, alpha] = imread(...)` returns the alpha channel if one is present. If no alpha channel is present, or if you specify 'BackgroundColor', then alpha is `[]`. The map output can be empty if the file contains a grayscale or truecolor image.

If you specify the alpha output argument, BG defaults to 'none', if not specified. Otherwise, if the PNG file contains a background color chunk, that color is used as the default value for BG. If alpha is not used and the file does not contain a background color chunk, then the default value for BG is 1 for indexed images; 0 for grayscale images; and `[0 0 0]` for truecolor (RGB) images.

## PPM – Portable Pixmap

| Supported Bitdepths | Raw Binary | ASCII (Plain Encoded) | Output Class |
|---------------------|------------|-----------------------|--------------|
| Up to 16-bit        | y          | –                     | uint8        |
| Arbitrary           | –          | y                     |              |

## RAS – Sun™ Raster

The following table lists the supported bitdepths, compression, and output classes for RAS files.

| Supported Bitdepths | Output Class | Notes                                      |
|---------------------|--------------|--------------------------------------------|
| 1-bit               | logical      | Bitmap                                     |
| 8-bit               | uint8        | Indexed                                    |
| 24-bit              | uint8        | RGB<br>Three 8-bit samples/pixel           |
| 32-bit              | uint8        | RGB with Alpha<br>Four 8-bit samples/pixel |

## TIFF – Tagged Image File Format

Most images supported by the TIFF specification or LibTIFF can be read by `imread`.

`imread` supports the following TIFF capabilities:

- Any number of samples-per-pixel
- CCITT group 3 and 4 FAX, Packbits, JPEG, LZW, Deflate, ThunderScan compression, and uncompressed images
- Logical, grayscale, indexed color, truecolor and hyperspectral images
- RGB, CMYK, CIELAB, ICCLAB color spaces. If the color image uses the CMYK color space, `A` is an M-by-N-by-4 array. To determine which color space is used, use `imfinfo` to get information about the graphics file and look at the value of the `PhotometricInterpretation` field. If a file contains CIELAB color data, `imread` converts it to ICCLAB before bringing it into the MATLAB workspace because 8- or 16-bit TIFF CIELAB-encoded values use a mixture of signed and unsigned data types that cannot be represented as a single MATLAB array.
- Data organized into tiles or scanlines

---

**Note**

- YCbCr images are converted into the RGB colorspace.
  - All grayscale images are read as if black=0, white=largest value.
  - 1-bit images are returned as class `logical`.
  - CIELab images are converted into ICCLab colorspace.
- 

The following are format-specific syntaxes for TIFF files.

`A = imread(...)` returns color data that uses the RGB, CIELAB, ICCLAB, or CMYK color spaces. If the color image uses the CMYK color space, `A` is an M-by-N-by-4 array.

`[...] = imread(..., 'Param1', value1, 'Param2', value2, ...)` uses parameter/value pairs to control the read operation. The following table lists the parameters you can use.

| Parameter     | Value                                                                                                                                                                                                                                                                  |
|---------------|------------------------------------------------------------------------------------------------------------------------------------------------------------------------------------------------------------------------------------------------------------------------|
| 'Index'       | Positive integer specifying which image to read. For example, if you specify the value 3, <code>imread</code> reads the third image in the file. If you omit this argument, <code>imread</code> reads the first image in the file.                                     |
| 'Info'        | Structure array returned by <code>imfinfo</code> .<br><br>Note: When reading images from a multi-image TIFF file, passing the output of <code>imfinfo</code> as the value of the 'Info' argument helps <code>imread</code> locate the images in the file more quickly. |
| 'PixelRegion' | Cell array, {Rows, Cols}, specifying the boundaries of the region. Rows and Cols must be either two- or three-element vectors. If you specify two elements, the values denote the 1-based indices [start stop]. If you specify                                         |



| Parameter | Value                                                                                                      |
|-----------|------------------------------------------------------------------------------------------------------------|
|           | three elements, the values denote the 1-based indices [start increment stop], to allow image downsampling. |

For copyright information, see the `libtiffcopyright.txt` file.

### XWD – X Window Dump

The following table lists the supported bitdepths, compression, and output classes for XWD files.

| Supported Bitdepths | ZPixmaps | XYBitmaps | XPixmaps | Output Class |
|---------------------|----------|-----------|----------|--------------|
| 1-bit               | y        | –         | y        | logical      |
| 8-bit               | y        | –         | –        | uint8        |

## Class Support

For most image file formats, `imread` uses 8 or fewer bits per color plane to store image pixels. The following table lists the class of the returned array for the data types used by the file formats.

| Data Type Used in File       | Class of Array Returned by <code>imread</code>                                                      |
|------------------------------|-----------------------------------------------------------------------------------------------------|
| 1-bit per pixel              | logical                                                                                             |
| 2- to 8-bits per color plane | uint8                                                                                               |
| 9- to 16-bit per pixel       | uint16 (BMP, JPEG, PNG, and TIFF)<br>For the 16-bit BMP packed format (5-6-5), MATLAB returns uint8 |

# imread

---

---

**Note** For indexed images, `imread` always reads the colormap into an array of class `double`, even though the image array itself may be of class `uint8` or `uint16`.

---

## Examples

### Read and Display Image

Read a sample image.

```
A = imread('ngc6543a.jpg');
```

`imread` returns a 650-by-600-by-3 array, `A`.

Display the image.

```
image(A)
```

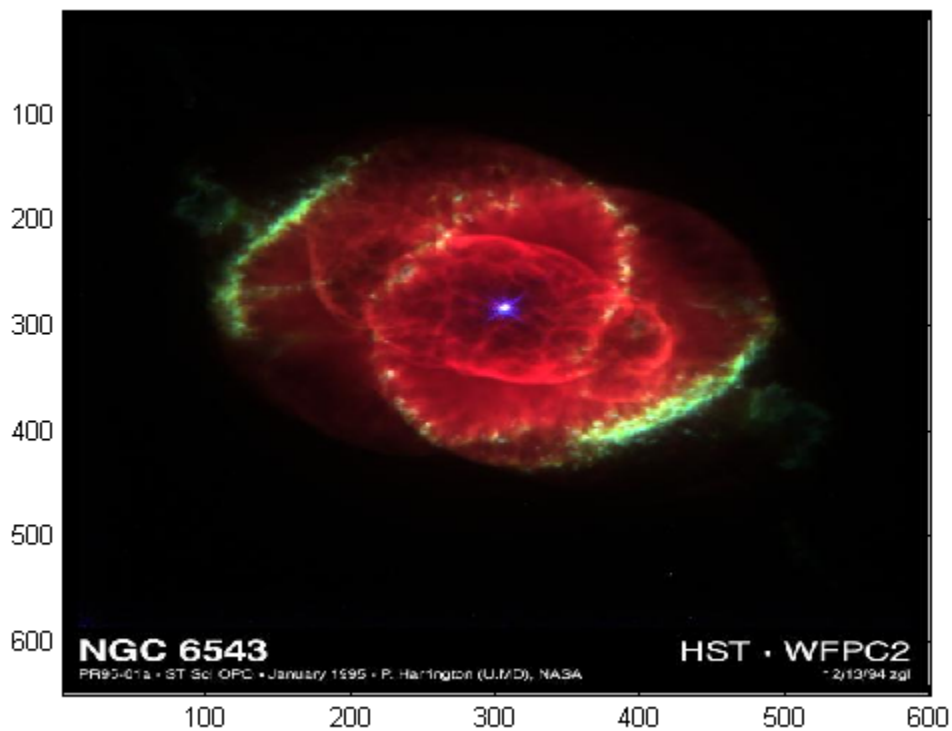

### Convert Indexed Image to RGB

Read an image and convert it to an RGB image.

Read the first image in the sample indexed image file, `corn.tif`.

```
[X,map] = imread('corn.tif');
```

X is a 415-by-312 array of type `uint8`.

# imread

---

Verify that the colormap, `map`, is not empty, and convert the data in `X` to RGB.

```
if ~isempty(map)
 Im = ind2rgb(X,map);
end
```

View the size and class of `X`.

```
whos Im
```

| Name | Size      | Bytes   | Class  | Attributes |
|------|-----------|---------|--------|------------|
| Im   | 415x312x3 | 3107520 | double |            |

`X` is now a 415-by-312-by-3 array of type double.

## Read Specific Image in Multi-Page TIFF File

Read the third image in the sample file, `corn.tif`.

```
[X,map] = imread('corn.tif',3);
```

## Return Alpha Channel of PNG Image

Return the alpha channel of the sample image, `peppers.png`.

```
[X,map,alpha] = imread('peppers.png');
alpha
```

```
alpha =
```

```
[]
```

No alpha channel is present, so `alpha` is empty.

## Read Specified Region of TIFF Image

Read a specific region of pixels of the sample image, `corn.tif`.

Specify the `'PixelRegion'` parameter with a cell array of vectors indicating the boundaries of the region to read. The first vector specifies

the range of rows to read, and the second vector specifies the range of columns to read.

```
A = imread('corn.tif', 'PixelRegion', {[1,2],[2,5]});
```

`imread` reads the image data in rows 1–2 and columns 2–5 from `corn.tif` and returns the 2-by-4 array, `A`.

## See Also

`double` | `fread` | `image` | `imfinfo` | `imformats` | `imwrite` | `ind2rgb` | `uint8` | `uint16`

# imwrite

---

**Purpose** Write image to graphics file

**Syntax** `imwrite(A,filename)`  
`imwrite(A,map,filename)`

`imwrite( __ ,fmt)`

`imwrite( __ ,Name,Value)`

**Description** `imwrite(A,filename)` writes image data `A` to the file specified by `filename`, inferring the file format from the extension. `imwrite` creates the new file in your current folder. The bit depth of the output image depends on the data type of `A` and the file format. For most formats:

- If `A` is of data type `uint8`, then `imwrite` outputs 8-bit values.
- If `A` is of data type `uint16` and the output file format supports 16-bit data (JPEG, PNG, and TIFF), then `imwrite` outputs 16-bit values. If the output file format does not support 16-bit data, then `imwrite` errors.
- If `A` is a grayscale or RGB color image of data type `double` or `single`, then `imwrite` assumes the dynamic range is `[0,1]` and automatically scales the data by 255 before writing it to the file as 8-bit values. If the data in `A` is `single`, convert `A` to `double` before writing to a GIF or TIFF file.
- If `A` is of data type `logical`, then `imwrite` assumes the data is a binary image and writes it to the file with a bit depth of 1, if the format allows it. BMP, PNG, or TIFF formats accept binary images as input arrays.

If `A` contains indexed image data, you should additionally specify the `map` input argument.

`imwrite(A,map,filename)` writes the indexed image in `A` and its associated colormap, `map`, to the file specified by `filename`.

- If `A` is an indexed image of data type `double` or `single`, then `imwrite` converts the indices to zero-based indices by subtracting 1 from each element, and then writes the data as `uint8`. If the data in `A` is `single`, convert `A` to `double` before writing to a GIF or TIFF file.

`imwrite( ___, fmt )` writes the image in the format specified by `fmt`, regardless of the file extension in `filename`. You can specify `fmt` after the input arguments in any of the previous syntaxes.

`imwrite( ___, Name, Value )` specifies additional parameters for output GIF, HDF, JPEG, PBM, PGM, PNG, PPM, and TIFF files, using one or more name-value pair arguments, in addition to any of the arguments in the previous syntaxes.

## Input Arguments

### **A - Image data to write**

matrix

Image data to write, specified as a full (nonsparse) matrix.

- For grayscale images, `A` can be `m`-by-`n`.
- For indexed images, `A` can be `m`-by-`n`. Specify the associated colormap in the `map` input argument.
- For truecolor images, `A` must be `m`-by-`n`-by-3.

For TIFF files, `A` can be an `m`-by-`n`-by-4 array containing color data that uses the CMYK color space.

For multiframe GIF files, `A` can be an `m`-by-`n`-by-1-by-`p` array containing grayscale or indexed images, where `p` is the number of frames to write. RGB images are not supported in this case.

### **Data Types**

`double` | `single` | `uint8` | `uint16` | `logical`

### **filename - Name of output file**

string

Name of the output file including the file extension, specified as a string. For a list of the image types that `imwrite` can write, see the description for the `fmt` input argument.

**Example:** `'myFile.gif'`

### Data Types

char

### map - Colormap of indexed image

m-by-3 array

Colormap associated with indexed image data in `A`, specified as an m-by-3 array. `map` must be a valid MATLAB colormap. See `colormap` for a list of built-in MATLAB colormaps. Most image file formats do not support colormaps with more than 256 entries.

**Example:** `[0,0,0;0.5,0.5,0.5;1,1,1]`

**Example:** `jet(60)`

### Data Types

double

### fmt - Format of output file

string

Format of the output file, specified as one of the following strings.

This table also summarizes the types of images that `imwrite` can write. The MATLAB file format registry determines which file formats are supported. See `imformats` for more information about this registry.

For certain formats, `imwrite` can accept additional name-value pair arguments. To view these arguments, click the linked format names below.



| Value of fmt    | Format of Output File                             | Description                                                                                                                                                                                                       |
|-----------------|---------------------------------------------------|-------------------------------------------------------------------------------------------------------------------------------------------------------------------------------------------------------------------|
| 'bmp'           | Windows Bitmap (BMP)                              | 1-bit, 8-bit, and 24-bit uncompressed images                                                                                                                                                                      |
| 'gif'           | Graphics Interchange Format (GIF)                 | 8-bit images                                                                                                                                                                                                      |
| 'hdf'           | Hierarchical Data Format (HDF4)                   | 8-bit raster image data sets with or without associated colormap, 24-bit raster image data sets                                                                                                                   |
| 'jpg' or 'jpeg' | Joint Photographic Experts Group (JPEG)           | 8-bit, 12-bit, and 16-bit Baseline JPEG images<br><br><b>Note</b> <code>imwrite</code> converts indexed images to RGB before writing data to JPEG files, because the JPEG format does not support indexed images. |
| 'jp2' or 'jpx'  | JPEG 2000 — Joint Photographic Experts Group 2000 | 1-bit, 8-bit, and 16-bit JPEG 2000 images                                                                                                                                                                         |
| 'pbm'           | Portable Bitmap (PBM)                             | Any 1-bit PBM image, ASCII (plain) or raw (binary) encoding                                                                                                                                                       |
| 'pcx'           | Windows Paintbrush (PCX)                          | 8-bit images                                                                                                                                                                                                      |

| <b>Value of fmt</b> | <b>Format of Output File</b>    | <b>Description</b>                                                                                                                                                                                                                                        |
|---------------------|---------------------------------|-----------------------------------------------------------------------------------------------------------------------------------------------------------------------------------------------------------------------------------------------------------|
| 'pgm'               | Portable Graymap (PGM)          | Any standard PGM image; ASCII (plain) encoded with arbitrary color depth; raw (binary) encoded with up to 16 bits per gray value                                                                                                                          |
| 'png'               | Portable Network Graphics (PNG) | 1-bit, 2-bit, 4-bit, 8-bit, and 16-bit grayscale images; 8-bit and 16-bit grayscale images with alpha channels; 1-bit, 2-bit, 4-bit, and 8-bit indexed images; 24-bit and 48-bit truecolor images; 24-bit and 48-bit truecolor images with alpha channels |
| 'pnm'               | Portable Anymap (PNM)           | Any of the PPM/PGM/PBM formats, chosen automatically                                                                                                                                                                                                      |
| 'ppm'               | Portable Pixmap (PPM)           | Any standard PPM image: ASCII (plain) encoded with arbitrary color depth or raw (binary) encoded with up to 16 bits per color component                                                                                                                   |
| 'ras'               | Sun Raster (RAS)                | Any RAS image, including 1-bit bitmap, 8-bit indexed, 24-bit truecolor and 32-bit truecolor with alpha                                                                                                                                                    |

| Value of <code>fmt</code> | Format of Output File           | Description                                                                                                                                                                                                                                                                                                                |
|---------------------------|---------------------------------|----------------------------------------------------------------------------------------------------------------------------------------------------------------------------------------------------------------------------------------------------------------------------------------------------------------------------|
| 'tif' or 'tiff'           | Tagged Image File Format (TIFF) | Baseline TIFF images, including: <ul style="list-style-type: none"> <li>• 1-bit, 8-bit, 16-bit, 24-bit, and 48-bit uncompressed images and images with packbits, LZW, or Deflate compression</li> <li>• 1-bit images with CCITT 1D, Group 3, and Group 4 compression</li> <li>• CIELAB, ICCLAB, and CMYK images</li> </ul> |
| 'xwd'                     | X Windows Dump (XWD)            | 8-bit ZPmaps                                                                                                                                                                                                                                                                                                               |

### Name-Value Pair Arguments

Specify optional comma-separated pairs of `Name`, `Value` arguments. `Name` is the argument name and `Value` is the corresponding value. `Name` must appear inside single quotes (' '). You can specify several name and value pair arguments in any order as `Name1,Value1,...,NameN,ValueN`.

**Example:** `imwrite(A, 'myFile.png', 'BitDepth', 8)` writes the data in `A` using 8 bits to represent each pixel.

### GIF — Graphics Interchange Format

#### 'BackgroundColor' - Color to use as background color

scalar integer

Color to use as background color for the indexed image, specified as the comma-separated pair consisting of 'BackgroundColor' and a scalar integer corresponding to the colormap index.

The background color is used for some disposal methods in animated GIFs.

- If image data A is `uint8` or `logical`, then the colormap index is zero-based.
- If image data A is `double`, then the colormap index is one-based.

The default background color corresponds to the first color in the colormap.

**Example:** `'BackgroundColor',15`

### **'Comment' - Comment to add to image**

`string` | `cell array of strings`

Comment to add to the image, specified as the comma-separated pair consisting of `'Comment'` and a string or a 1-by-n cell array of strings. For a cell array of strings, `imwrite` adds a carriage return after each string.

**Example:** `'Comment',{'Sample #314','January 5, 2013'}`

### **Data Types**

`char` | `cell`

### **'DelayTime' - Delay before displaying next image**

0.5 (default) | scalar value in the range [0,655]

Delay before displaying next image, in seconds, specified as the comma-separated pair consisting of `'DelayTime'` and a scalar value in the range [0,655]. A value of 0 displays images as fast as your hardware allows.

**Example:** `'DelayTime',60`

### **'DisposalMethod' - Disposal method of animated GIF**

`'doNotSpecify'` (default) | `'leaveInPlace'` | `'restoreBG'` | `'restorePrevious'`

Disposal method of an animated GIF, specified as the comma-separated pair consisting of `'DisposalMethod'` and one of the following strings.

| Value of DisposalMethod  | Result                                                                    |
|--------------------------|---------------------------------------------------------------------------|
| 'doNotSpecify' (default) | Replace one full-size, nontransparent frame with another.                 |
| 'leaveInPlace'           | Any pixels not covered up by the next frame continue to display.          |
| 'restoreBG'              | The background color or background tile shows through transparent pixels. |
| 'restorePrevious'        | Restore to the state of a previous, undisposed frame.                     |

**Example:** 'DisposalMethod', 'restoreBG'

### 'Location' - Offset of screen relative to image

[0,0] (default) | two-element vector

Offset of the screen relative to the image, measured from the top left corner of each, specified as the comma-separated pair consisting of 'Location' and a two-element vector. The first vector element specifies the offset from the top, and the second element specifies the offset from the left, in pixels.

**Example:** 'Location', [10,15]

### Data Types

double

### 'LoopCount' - Number of times to repeat animation

Inf (default) | integer in the range [0,65535]

Number of times to repeat the animation, specified as the comma-separated pair consisting of 'LoopCount' and either an integer in the range [0,65535], or the value Inf. If you specify 0, the animation plays once. If you specify the value 1, the animation plays twice, and so on. A LoopCount value of Inf causes the animation to continuously loop.

To enable animation within Microsoft PowerPoint®, specify a value for 'LoopCount' within the range [1,65535]. Some Microsoft applications interpret the value 0 to mean do not loop at all.

**Example:** 'LoopCount',3

## **'ScreenSize' - Height and width of frame**

height and width of input image (default) | two-element vector

Height and width of the frame, specified as the comma-separated pair consisting of 'ScreenSize' and a two-element vector. When you use the ScreenSize argument with 'Location', it provides a way to write frames to the image that are smaller than the whole frame. 'DisposalMethod' determines the fill value for pixels outside the frame.

**Example:** 'ScreenSize',[1000 1060]

## **Data Types**

double

## **'TransparentColor' - Color to use as transparent color**

scalar integer

Color to use as transparent color for the image, specified as the comma-separated pair consisting of 'TransparentColor' and a scalar integer corresponding to the colormap index.

- If image data A is uint8 or logical, then indexing begins at 0.
- If image data A is double, then indexing begins at 1.

**Example:** 'TransparentColor',20

## **'WriteMode' - Writing mode**

'overwrite' (default) | 'append'

Writing mode, specified as the comma-separated pair consisting of 'WriteMode' and either 'overwrite' or 'append'. In overwrite mode, imwrite overwrites an existing file,filename. In append mode, imwrite adds a single frame to the existing file.

**Example:** 'WriteMode', 'append'

## HDF4 — Hierarchical Data Format

### 'Compression' - Compression scheme

'none' (default) | 'jpeg' | 'rle'

Compression scheme, specified as the comma-separated pair consisting of 'Compression' and one of the following strings.

| Value of Compression | Result                                                            |
|----------------------|-------------------------------------------------------------------|
| 'none' (default)     | No compression                                                    |
| 'jpeg'               | JPEG compression. Valid only for grayscale and RGB images.        |
| 'rle'                | Run-length encoding. Valid only for grayscale and indexed images. |

**Example:** 'Compression', 'jpeg'

### 'Quality' - Quality of JPEG-compressed file

75 (default) | scalar in the range [0,100]

Quality of the JPEG-compressed file, specified as the comma-separated pair consisting of 'Quality' and a scalar in the range [0,100], where 0 is lower quality and higher compression, and 100 is higher quality and lower compression. This parameter applies only if 'Compression' is 'jpeg'.

**Example:** 'Quality', 25

### 'WriteMode' - Writing mode

'overwrite' (default) | 'append'

Writing mode, specified as the comma-separated pair consisting of 'WriteMode' and either 'overwrite' or 'append'. In overwrite mode, `imwrite` overwrites an existing file, `filename`. In append mode, `imwrite` adds a single frame to the existing file.

**Example:** `'WriteMode','append'`

## JPEG — Joint Photographic Experts Group

### **'BitDepth' - Number of bits per pixel**

8 (default) | scalar

Number of bits per pixel, specified as the comma-separated pair consisting of 'BitDepth' and a scalar.

- For grayscale images, the BitDepth value can be 8, 12, or 16. The default value is 8. For 16-bit images, the 'Mode' name-value pair argument must be 'lossless'.
- For color images, the BitDepth value is the number of bits per plane, and can be 8 or 12. The default is 8 bits per plane.

**Example:** `'BitDepth',12`

### **'Comment' - Comment to add to image**

string | character array | n-by-1 cell array of strings

Comment to add to the image, specified as the comma-separated pair consisting of 'Comment' and a single string, a character array, or an n-by-1 cell array of strings. `imwrite` writes each row of input as a comment in the JPEG file.

**Example:** `'Comment',{'First line';'second line';'third line'}`

### **Data Types**

char | cell

### **'Mode' - Type of compression**

'lossy' (default) | 'lossless'

Type of compression, specified as the comma-separated pair consisting of 'Mode' and one of the following strings:

- 'lossy'
- 'lossless'



**Example:** 'Mode', 'lossless'

### **'Quality' - Quality of output file**

75 (default) | scalar in the range [0,100]

Quality of the output file, specified as the comma-separated pair consisting of 'Quality' and a scalar in the range [0,100], where 0 is lower quality and higher compression, and 100 is higher quality and lower compression. A Quality value of 100 does not write a lossless JPEG image. Instead, use the 'Mode', 'lossless' name-value pair argument.

**Example:** 'Quality', 100

## **JPEG 2000— Joint Photographic Experts Group 2000**

### **'Comment' - Comment to add to image**

string | character array | cell array of strings

Comment to add to the image, specified as the comma-separated pair consisting of 'Comment' and a single string, a character array, or a cell array of strings. `imwrite` writes each row of input as a comment in the JPEG 2000 file.

**Example:** 'Comment', {'First line'; 'second line'; 'third line'}

**Example:** 'Comment', {'First line', 'second line', 'third line'}

### **Data Types**

cell | char

### **'CompressionRatio' - Target compression ratio**

1 (default) | scalar

Target compression ratio, specified as the comma-separated pair consisting of 'CompressionRatio' and a real scalar greater than or equal to 1. The compression ratio is the ratio of the input image size to the output compressed size. For example, a value of 2.0 implies that the

output image size is half of the input image size or less. A higher value implies a smaller file size and reduced image quality. The compression ratio does not take into account the header size.

Specifying `CompressionRatio` is valid only when `'Mode'` is `'lossy'`.

**Example:** `'CompressionRatio',3`

### **'Mode' - Type of compression**

`'lossy'` (default) | `'lossless'`

Type of compression, specified as the comma-separated pair consisting of `'Mode'` and one of the following strings:

- `'lossy'`
- `'lossless'`

**Example:** `'Mode','lossless'`

### **'ProgressionOrder' - Order of packets in code stream**

`'LRCP'` (default) | `'RLCP'` | `'RPCL'` | `'PCRL'` | `'CPRL'`

Order of packets in the code stream, specified as the comma-separated pair consisting of `'ProgressionOrder'` and one of the following strings:

- `'LRCP'`
- `'RLCP'`
- `'RPCL'`
- `'PCRL'`
- `'CPRL'`

The characters in the text strings represent the following: L = layer, R = resolution, C = component and P = position.

**Example:** `'ProgressionOrder','RLCP'`

### **'QualityLayers' - Number of quality layers**

1 (default) | integer in the range [1,20]

Number of quality layers, specified as the comma-separated pair consisting of 'QualityLayers' and an integer in the range [1,20].

**Example:** 'QualityLayers',8

### **'ReductionLevels' - Number of reduction levels**

4 (default) | integer in the range [1,8]

Number of reduction levels, or wavelet decomposition levels, specified as the comma-separated pair consisting of 'ReductionLevels' and an integer in the range [1,8].

**Example:** 'ReductionLevels',6

### **'TileSize' - Tile height and width**

image size (default) | two-element vector

Tile height and width, specified as the comma-separated pair consisting of 'TileSize' and a two-element vector. The minimum size you can specify is [128 128].

**Example:** 'TileSize',[130 130]

## **PBM-, PGM-, and PPM — Portable Bitmap, Graymap, Pixmap**

### **'Encoding' - Encoding**

'rawbits' (default) | 'ASCII'

Encoding, specified as the comma-separated pair consisting of 'Encoding' and either 'rawbits' for binary encoding, or 'ASCII' for plain encoding.

**Example:** 'Encoding','ASCII'

### **'MaxValue' - Maximum gray or color value**

scalar

Maximum gray or color value, specified as the comma-separated pair consisting of 'MaxValue' and a scalar.

Available only for PGM and PPM files. For PBM files, this value is always 1.

If the image array is `uint16`, then the default value for `MaxValue` is 65535. Otherwise, the default value is 255.

**Example:** `'MaxValue',510`

## **PNG — Portable Network Graphics**

In addition to the following name-value pair arguments, you can use any parameter name that satisfies the PNG specification for keywords. That is, the name uses only printable characters, contains 80 or fewer characters, and does not contain leading or trailing spaces. The value corresponding to these user-specified names must be a string that contains no control characters other than linefeed.

### **'Alpha' - Transparency of each pixel**

matrix of values in the range [0,1]

Transparency of each pixel, specified as the comma-separated pair consisting of 'Alpha' and a matrix of values in the range [0,1]. The row and column dimensions of the Alpha matrix must be the same as those of the image data array. You can specify Alpha only for grayscale (m-by-n) and truecolor (m-by-n-by-3) image data.

---

**Note** You cannot specify both 'Alpha' and 'Transparency' at the same time.

---

### **Data Types**

double | uint8 | uint16

### **'Author' - Author information**

string

Author information, specified as the comma-separated pair consisting of 'Author' and a string.

**Example:** "Author", 'Ann Smith'

### Data Types

char

### 'Background' - Background color when compositing transparent pixels

scalar in the range [0,1] | integer in the range [1,P] | 3-element vector in the range [0,1]

Background color when compositing transparent pixels, specified as the comma-separated pair consisting of 'Background' and a value dependent on the image data, as follows.

| Image Type       | Form of Background Value                                                                                                                                                     |
|------------------|------------------------------------------------------------------------------------------------------------------------------------------------------------------------------|
| Grayscale images | Scalar in the range [0,1].                                                                                                                                                   |
| Indexed images   | Integer in the range [1,P], where P is the colormap length. For example, 'Background',50 sets the background color to the color specified by the 50th index in the colormap. |
| Truecolor images | Three-element vector of RGB intensities in the range [0,1]. For example, 'Background',[0 1 1] sets the background color to cyan.                                             |

### Data Types

double

### 'BitDepth' - Number of bits per pixel

scalar

Number of bits per pixel, specified as the comma-separated pair consisting of 'BitDepth' and a scalar. Depending on the output image, the scalar can be one of the following values.

| Image Type                             | Allowed Values for BitDepth |
|----------------------------------------|-----------------------------|
| Grayscale images                       | 1, 2, 4, 8, or 16           |
| Grayscale images with an alpha channel | 8 or 16                     |
| Indexed images                         | 1, 2, 4, or 8               |
| Truecolor images                       | 8 or 16                     |

- If the image is of class `double` or `uint8`, then the default bit depth is 8 bits per pixel.
- If the image is `uint16`, then the default is 16 bits per pixel.
- If the image is `logical`, then the default is 1 bit per pixel.

**Example:** `'BitDepth',4`

### **'Chromaticities' - Reference white point and primary chromaticities**

8-element vector

Reference white point and primary chromaticities, specified as the comma-separated pair consisting of `'Chromaticities'` and an 8-element vector, `[wx wy rx ry gx gy bx by]`. The elements `wx` and `wy` are the chromaticity coordinates of the white point, and the elements `rx`, `ry`, `gx`, `gy`, `bx`, and `by` are the chromaticity coordinates of the three primary colors.

If you specify `Chromaticities`, you should also specify the `Gamma` name-value pair argument.

**Example:**

```
'Chromaticities',[0.312,0.329,0.002,0.002,0.001,0.001,0.115,0.312]
```

### **Data Types**

`double`

### **'Comment' - Comment to add to image**

`string`

Comment to add to the image, specified as the comma-separated pair consisting of 'Comment' and a string.

**'Copyright' - Copyright notice**

string

Copyright notice, specified as the comma-separated pair consisting of 'Copyright' and a string.

**'CreationTime' - Time of original image creation**

string

Time of original image creation, specified as a string.

**'Description' - Description of image**

string

Description of the image, specified as the comma-separated pair consisting of 'Description' and a string.

**'Disclaimer' - Legal disclaimer**

string

Legal disclaimer, specified as the comma-separated pair consisting of 'Disclaimer' and a string.

**'Gamma' - File gamma**

scalar

File gamma, specified as the comma-separated pair consisting of 'Gamma' and a scalar.

**Example:** 'Gamma',2.2

**'ImageModTime' - Time of last image modification**

serial date number | date string

Time of the last image modification, specified as the comma-separated pair consisting of 'ImageModTime' and a MATLAB serial date number

or a date string that can be converted to a date vector using the `datevec` function. Values should be in Coordinated Universal Time (UTC).

The default `ImageModTime` value is the time when you call `imwrite`.

**Example:** `'ImageModTime','17-Jan-2013 11:23:10'`

## Data Types

`double` | `char`

### 'InterlaceType' - Interlacing scheme

`'none'` (default) | `'adam7'`

Interlacing scheme, specified as the comma-separated pair consisting of `'InterlaceType'` and either `'none'` for no interlacing, or `'adam7'` to use the Adam7 algorithm.

**Example:** `'InterlaceType','adam7'`

### 'ResolutionUnit' - Unit for image resolution

`'unknown'` (default) | `'meter'`

Unit for image resolution, specified as the comma-separated pair consisting of `'ResolutionUnit'` and either `'unknown'` or `'meter'`. If you specify `ResolutionUnit`, you must include at least one of the `XResolution` and `YResolution` name-value pair arguments. When the value of `ResolutionUnit` is `'meter'`, the `XResolution` and `YResolution` values are interpreted in pixels per meter.

**Example:** `'ResolutionUnit','meter','XResolution',1000`

### 'SignificantBits' - Number of bits to regard as significant

`[]` (default) | `scalar` | `vector`

Number of bits in the data array to regard as significant, specified as the comma-separated pair consisting of `'SignificantBits'` and a scalar or a vector in the range `[1,BitDepth]`. Depending on the output image type, the value must be in the following form.



| <b>Image Type</b>                        | <b>Form of SignificantBits Value</b> |
|------------------------------------------|--------------------------------------|
| Grayscale image without an alpha channel | Scalar                               |
| Grayscale image with an alpha channel    | 2-element vector                     |
| Indexed image                            | 3-element vector                     |
| Truecolor image without an alpha channel | 3-element vector                     |
| Truecolor image with an alpha channel    | 4-element vector                     |

**Example:** `'SignificantBits',[2,3]`

#### **'Software' - Software used to create the image**

string

Software used to create the image, specified as the comma-separated pair consisting of 'Software' and a string.

#### **'Source' - Device used to create the image**

string

Device used to create the image, specified as the comma-separated pair consisting of 'Source' and a string.

#### **'Transparency' - Pixels to consider transparent**

[ ] (default) | scalar in the range [0,1] | vector

Pixels to consider transparent when no alpha channel is used, specified as the comma-separated pair consisting of 'Transparency' and a scalar or a vector. Depending on the output image, the value must be in the following form.

| <b>Image Type</b> | <b>Form of Transparency Value</b>                                                                                                                                                                              |
|-------------------|----------------------------------------------------------------------------------------------------------------------------------------------------------------------------------------------------------------|
| Grayscale images  | Scalar in the range [0,1], indicating the grayscale color to be considered transparent.                                                                                                                        |
| Indexed images    | Q-element vector of values in the range [0,1], where Q is no larger than the colormap length and each value indicates the transparency associated with the corresponding colormap entry. In most cases, Q = 1. |
| Truecolor images  | 3-element vector of RGB intensities in the range [0,1], indicating the truecolor color to consider transparent.                                                                                                |

---

**Note** You cannot specify both 'Transparency' and 'Alpha' at the same time.

---

**Example:** 'Transparency',[1 1 1]

### **Data Types**

double

### **'Warning' - Warning of nature of content**

string

Warning of nature of content, specified as the comma-separated pair consisting of 'Warning' and a string.

### **'XResolution' - Image resolution in horizontal direction**

scalar

Image resolution in the horizontal direction, in pixels/unit, specified as the comma-separated pair consisting of 'XResolution' and a scalar. Define the unit by specifying the ResolutionUnit name-value pair argument.

If you do not also specify YResolution, then the XResolution value applies to both the horizontal and vertical directions.

**Example:** 'XResolution',900

### **'YResolution' - Image resolution in vertical direction**

scalar

Image resolution in the vertical direction, in pixels/unit, specified as the comma-separated pair consisting of 'XResolution' and a scalar. Define the unit by specifying the ResolutionUnit name-value pair argument.

If you do not also specify XResolution, then the YResolution value applies to both the horizontal and vertical directions.

**Example:** 'YResolution',900

## **RAS — Sun Raster Graphic**

### **'Alpha' - Transparency of each pixel**

[] (default) | matrix

Transparency of each pixel, specified as the comma-separated pair consisting of 'Alpha' and a matrix with row and column dimensions the same as those of the image data array.

Valid only for truecolor (m-by-n-by-3) image data.

### **Data Types**

double | single | uint8 | uint16

### **'Type' - Image type**

'standard' (default) | 'rgb' | 'rle'

Image type, specified as the comma-separated pair consisting of 'Type' and one of the following strings.

| Value of Type        | Description                                          |
|----------------------|------------------------------------------------------|
| 'standard' (default) | Uncompressed, B-G-R color order for truecolor images |
| 'rgb'                | Uncompressed, R-G-B color order for truecolor images |
| 'rle'                | Run-length encoding of 1-bit and 8-bit images        |

Example: 'Type', 'rgb'

## TIFF — Tagged Image File Format

### 'ColorSpace' - Color space representing color data

'rgb' (default) | 'cielab' | 'icclab'

Color space representing the color data, specified as the comma-separated pair consisting of 'ColorSpace' and one of the following strings:

- 'rgb'
- 'cielab'
- 'icclab'

Valid only when the image data array, A, is truecolor (m-by-n-by-3). To use the CMYK color space in a TIFF file, do not use the 'ColorSpace' name-value pair argument. Instead, specify an m-by-n-by-4 image data array.

`imwrite` can write color image data that uses the  $L^*a^*b^*$  color space to TIFF files. The 1976 CIE  $L^*a^*b^*$  specification defines numeric values that represent luminance ( $L^*$ ) and chrominance ( $a^*$  and  $b^*$ ) information. To store  $L^*a^*b^*$  color data in a TIFF file, the values must be encoded to fit into either 8-bit or 16-bit storage. `imwrite` can store  $L^*a^*b^*$  color data in a TIFF file using the following encodings:

- CIELAB encodings — 8-bit and 16-bit encodings defined by the TIFF specification

- ICCLAB encodings — 8-bit and 16-bit encodings defined by the International Color Consortium

The output class and encoding used by `imwrite` depends on the class of the input image data array and the `ColorSpace` value, as shown in the following table. (The 8-bit and 16-bit CIELAB encodings cannot be input arrays because they use a mixture of signed and unsigned values and cannot be represented as a single MATLAB array.)

| Input Class and Encoding                                                                                                                                                             | Value of ColorSpace | Output Class and Encoding |
|--------------------------------------------------------------------------------------------------------------------------------------------------------------------------------------|---------------------|---------------------------|
| 8-bit ICCLAB<br><br>Values are integers in the range [0 255]. $L^*$ values are multiplied by 255/100. 128 is added to both the $a^*$ and $b^*$ values.                               | 'icclab'            | 8-bit ICCLAB              |
|                                                                                                                                                                                      | 'cielab'            | 8-bit CIELAB              |
| 16-bit ICCLAB<br><br>Values are integers in the range [0, 65280]. $L^*$ values are multiplied by 65280/100. 32768 is added to both the $a^*$ and $b^*$ values, which are represented | 'icclab'            | 16-bit ICCLAB             |
|                                                                                                                                                                                      | 'cielab'            | 16-bit CIELAB             |

| Input Class and Encoding                                                                                                                                                                             | Value of ColorSpace | Output Class and Encoding |
|------------------------------------------------------------------------------------------------------------------------------------------------------------------------------------------------------|---------------------|---------------------------|
| as integers in the range [0,65535].                                                                                                                                                                  |                     |                           |
| Double-precision 1976 CIE $L^*a^*b^*$ values<br><br>$L^*$ is in the dynamic range [0, 100]. $a^*$ and $b^*$ can take any value. Setting $a^*$ and $b^*$ to 0 (zero) produces a neutral color (gray). | 'icclab'            | 8-bit ICCLAB              |
|                                                                                                                                                                                                      | 'cielab'            | 8-bit CIELAB              |

**Example:** 'ColorSpace', 'cielab'

### 'Compression' - Compression scheme

'packbits' | 'none' | 'lzw' | 'deflate' | 'jpeg' | 'ccitt' | 'fax3' | 'fax4'

Compression scheme, specified as the comma-separated pair consisting of 'Compression' and one of the following strings:

- 'packbits' (default for nonbinary images)
- 'none'
- 'lzw'
- 'deflate'
- 'jpeg'
- 'ccitt' (binary images only, and the default for such images)
- 'fax3' (binary images only)

- 'fax4' (binary images only)

'jpeg' is a lossy compression scheme; other compression modes are lossless. Also, if you specify 'jpeg' compression, you must specify the 'RowsPerStrip' parameter and the value must be a multiple of 8.

**Example:** 'Compression','none'

### **'Description' - Image description**

string

Image description, specified by the comma-separated pair consisting of 'Description' and a string. This is the text that `imfinfo` returns in the `ImageDescription` field for the output image.

**Example:** 'Description','Sample 2A301'

### **'Resolution' - X- and Y-resolution**

72 (default) | scalar | two-element vector

X- and Y-resolution, specified as the comma-separated pair consisting of 'Resolution' and a scalar indicating both resolution, or a two-element vector containing the X-Resolution and Y-Resolution.

**Example:** 'Resolution',80

**Example:** 'Resolution',[320,72]

### **Data Types**

double

### **'RowsPerStrip' - Number of rows to include in each strip**

scalar

Number of rows to include in each strip, specified as the comma-separated pair consisting of 'RowsPerStrip' and a scalar. The default value is such that each strip is about 8 kilobytes.

You must specify `RowsPerStrip` if you specify 'jpeg' compression. The value must be a multiple of 8.

**Example:** 'RowsPerStrip',16

## Data Types

double | single | int8 | int16 | int32 | int64 | uint8 |  
uint16 | uint32 | uint64

## 'WriteMode' - Writing mode

'overwrite' (default) | 'append'

Writing mode, specified as the comma-separated pair consisting of 'WriteMode' and either 'overwrite' or 'append'. In overwrite mode, `imwrite` overwrites an existing file. In append mode, `imwrite` adds a page to the existing file.

**Example:** 'WriteMode', 'append'

## Examples

### Resize and Save Image

Read the sample image, `ngc6543a.jpg`, and the resize it to 500-by-500.

```
A = imread('ngc6543a.jpg');
B = imresize(A,[500 500]);
```

Write the resized image data, `B`, to a file.

```
imwrite(B,'myNewFile.tif');
```

`imwrite` writes the file, `myNewFile.tif`, to the current folder.

### Write Indexed Image Data to PNG

Write an indexed image array and its associated colormap to a PNG file.

Load sample image data from the file, `clown.mat`.

```
load clown.mat
```

The image array `X` and its associated colormap, `map`, are loaded into the MATLAB workspace.

Write the data to a new PNG file.

```
imwrite(X,map,'myclown.png')
```



`imwrite` creates the file, `myclown.png`, in your current folder.

View the new file by opening it outside of MATLAB.



### Write Indexed Image with MATLAB Colormap

Write image data to a new PNG file with the built-in MATLAB colormap, `copper`.

Load sample image data from the file `clown.mat`.

```
load clown.mat
```

The image array `X` and its associated colormap, `map`, are loaded into the MATLAB workspace. `map` is a matrix of 81 RGB vectors.

Define a copper-tone colormap with 81 RGB vectors. Then, write the image data to a PNG file using the new colormap.

```
newmap = copper(81);
```

```
imwrite(X,newmap,'copperclown.png');
```

`imwrite` creates the file, `copperclown.png`, in your current folder.

View the new file by opening it outside of MATLAB.



## Write Grayscale Image to PNG

Write a 50-by-50 array, `A`, of grayscale values to a PNG file.

```
A = rand(50,50);
imwrite(A,'myGray.png','png');
```

The third input, `'png'`, specifies that the output file is a PNG file.

## Write Truecolor Image to JPEG

Create and write truecolor image data to a JPEG file.

Create a 49-by-49-by-3 array of random RGB values.

```
A = rand(49,49);
A(:,:,2) = rand(49,49);
A(:,:,3) = rand(49,49);
```

Write the image data to a JPEG file, specifying the output format using the string, 'jpg'. Add a comment to the file using the 'Comment' name-value pair argument.

```
imwrite(A,'newImage.jpg','jpg','Comment','My JPEG file')
```

View information about the new file.

```
imfinfo('newImage.jpg')
```

```
ans =
```

```
 Filename: 'S:\newImage.jpg'
 FileModDate: '25-Jan-2013 16:18:41'
 FileSize: 2339
 Format: 'jpg'
FormatVersion: ''
 Width: 49
 Height: 49
 BitDepth: 24
 ColorType: 'truecolor'
FormatSignature: ''
NumberOfSamples: 3
 CodingMethod: 'Huffman'
CodingProcess: 'Sequential'
 Comment: {'My JPEG file'}
```

### Write Multiple Images to TIFF File

Write multiple images to a single multipage TIFF file.

Create two sets of random image data, `im1` and `im2`.

```
im1 = rand(50,40,3);
im2 = rand(50,50,3);
```

Write the first image to a new TIFF file. Then, append the second image to the same file.

```
imwrite(im1,'myMultipageFile.tif');
imwrite(im2,'myMultipageFile.tif','WriteMode','append');
```

## Write Animated GIF

Animate a series of plots and write the result to a GIF file.

Define the x-axis limits for the plot and specify the output file name.

```
x = 0:0.01:1;
figure
filename = 'testAnimated.gif';
```

Call `frame2im` to get image data from a single movie frame. Because three-dimensional data is not supported for GIF files, call `rgb2ind` to convert the RGB data in the image data, `im`, to an indexed image, `A`, with a colormap, `map`. Call `imwrite` with the name-value pair argument, `'WriteMode','append'`, to append multiple images to the first image.

```
for n = 1:0.5:5
 y = x.^n;
 plot(x,y)
 drawnow
 frame = getframe(1);
 im = frame2im(frame);
 [A,map] = rgb2ind(im,256);
 if n == 1;
 imwrite(A,map,filename,'gif','LoopCount',Inf,'DelayTime',1);
 else
 imwrite(A,map,filename,'gif','WriteMode','append','DelayTime',1);
 end
end
```

`imwrite` writes the GIF file to your current folder. Name-value pair `'LoopCount',Inf` causes the animation to continuously loop.

'DelayTime',1 specifies a 1-second delay between the display of each image in the animation.

**Tips**

- For copyright information, see the `libtiffcopyright.txt` file.

**See Also**

`fwrite` | `getframe` | `imfinfo` | `imformats` | `imread` | `Tiff`

# TriRep.incenters

---

**Purpose** (Will be removed) Incenters of specified simplices

---

**Note** `incenters(TriRep)` will be removed in a future release. Use `incenter(triangulation)` instead.

---

`TriRep` will be removed in a future release. Use `triangulation` instead.

---

**Syntax**  
`IC = inceters(TR,SI)`  
`[IC RIC] = inceters(TR, SI)`

**Description**  
`IC = inceters(TR,SI)` returns the coordinates of the incenter of each specified simplex `SI`.  
`[IC RIC] = inceters(TR, SI)` returns the incenters and the corresponding radius of the inscribed circle/sphere.

**Input Arguments**

|    |                                                                                                                                                                                                                                                                                                                               |
|----|-------------------------------------------------------------------------------------------------------------------------------------------------------------------------------------------------------------------------------------------------------------------------------------------------------------------------------|
| TR | Triangulation representation.                                                                                                                                                                                                                                                                                                 |
| SI | Column vector of simplex indices that index into the triangulation matrix <code>TR.Triangulation</code> . If <code>SI</code> is not specified the incenter information for the entire triangulation is returned, where the incenter associated with simplex <code>i</code> is the <code>i</code> 'th row of <code>IC</code> . |

**Output Arguments**

|     |                                                                                                                                                                                                                                                                                                              |
|-----|--------------------------------------------------------------------------------------------------------------------------------------------------------------------------------------------------------------------------------------------------------------------------------------------------------------|
| IC  | <code>m</code> -by- <code>n</code> matrix, where <code>m = length(SI)</code> , the number of specified simplices, and <code>n</code> is the dimension of the space where the triangulation resides. Each row <code>IC(i,:)</code> represents the coordinates of the incenter of simplex <code>SI(i)</code> . |
| RIC | Vector of length <code>length(SI)</code> , the number of specified simplices.                                                                                                                                                                                                                                |

## Definitions

A simplex is a triangle/tetrahedron or higher-dimensional equivalent.

## Examples

### Example 1

Load a 3-D triangulation:

```
load tetmesh
```

Use TriRep to compute the incenters of the first five tetrahedra.

```
trep = TriRep(tet, X)
ic = incenters(trep, [1:5]')
```

### Example 2

Query a 2-D triangulation created with DelaunayTri.

```
x = [0 1 1 0 0.5]';
y = [0 0 1 1 0.5]';
dt = DelaunayTri(x,y);
```

Compute incenters of the triangles:

```
ic = incenters(dt);
```

Plot the triangles and incenters:

```
triplot(dt);
axis equal;
axis([-0.2 1.2 -0.2 1.2]);
hold on;
plot(ic(:,1),ic(:,2),'*r');
hold off;
```

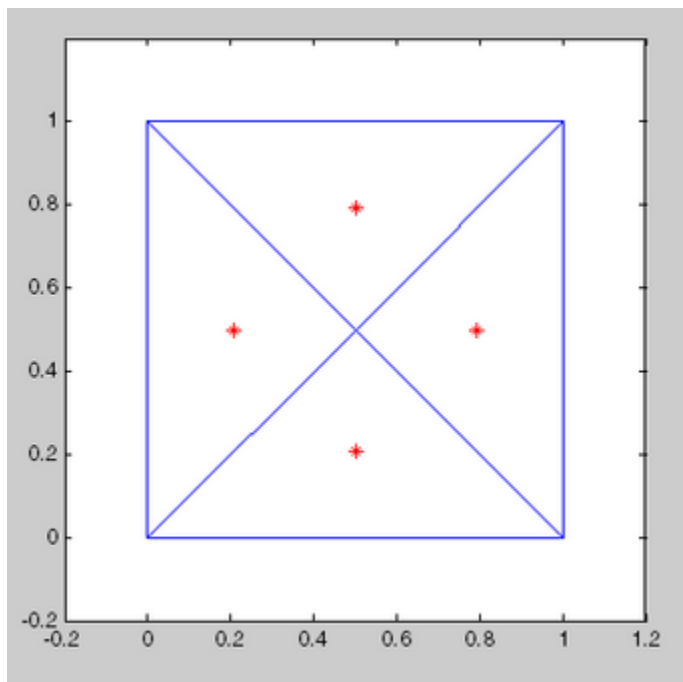

## See Also

[delaunayTriangulation](#) | [circumcenter](#) | [triangulation](#)



## Purpose

(Will be removed) Status of triangles in 2-D constrained Delaunay triangulation

---

**Note** `inOutStatus(DelaunayTri)` will be removed in a future release. Use `isInterior(delaunayTriangulation)` instead.

`DelaunayTri` will be removed in a future release. Use `delaunayTriangulation` instead.

---

## Syntax

`IN = inOutStatus(DT)`

## Description

`IN = inOutStatus(DT)` returns the in/out status of the triangles in a 2-D constrained Delaunay triangulation of a geometric domain. Given a Delaunay triangulation that has a set of constrained edges that define a bounded geometric domain. The *i*'th triangle in the triangulation is classified as inside the domain if `IN(i) = 1` and outside otherwise.

---

**Note** `inOutStatus` is only relevant for 2-D constrained Delaunay triangulations where the imposed edge constraints bound a closed geometric domain.

---

## Input Arguments

DT                      Delaunay triangulation.

## Output Arguments

IN                      Logical array of length equal to the number of triangles in the triangulation. The constrained edges in the triangulation define the boundaries of a valid geometric domain.

# DelaunayTri.inOutStatus

---

## Examples

Create a geometric domain that consists of a square with a square hole:

```
outerprofile = [-5 -5; -3 -5; -1 -5; 1 -5; 3 -5; ...
 5 -5; 5 -3; 5 -1; 5 1; 5 3;...
 5 5; 3 5; 1 5; -1 5; -3 5; ...
 -5 5; -5 3; -5 1; -5 -1; -5 -3;];
innerprofile = outerprofile.*0.5;
profile = [outerprofile; innerprofile];
outercons = [(1:19)' (2:20)'; 20 1;];
innercons = [(21:39)' (22:40)'; 40 21];
edgeconstraints = [outercons; innercons];
```

Create a constrained Delaunay triangulation of the domain:

```
dt = DelaunayTri(profile, edgeconstraints)
subplot(1,2,1);
triplot(dt);
hold on;
plot(dt.X(outercons',1), dt.X(outercons',2), ...
 '-r', 'LineWidth', 2);
plot(dt.X(innercons',1), dt.X(innercons',2), ...
 '-r', 'LineWidth', 2);
axis equal;
% Plot showing interior and exterior
% triangles with respect to the domain.
hold off;
subplot(1,2,2);
inside = inOutStatus(dt);
triplot(dt(inside, :), dt.X(:,1), dt.X(:,2));
hold on;
plot(dt.X(outercons',1), dt.X(outercons',2), ...
 '-r', 'LineWidth', 2);
plot(dt.X(innercons',1), dt.X(innercons',2), ...
 '-r', 'LineWidth', 2);
axis equal;
% Plot showing interior triangles only
hold off;
```

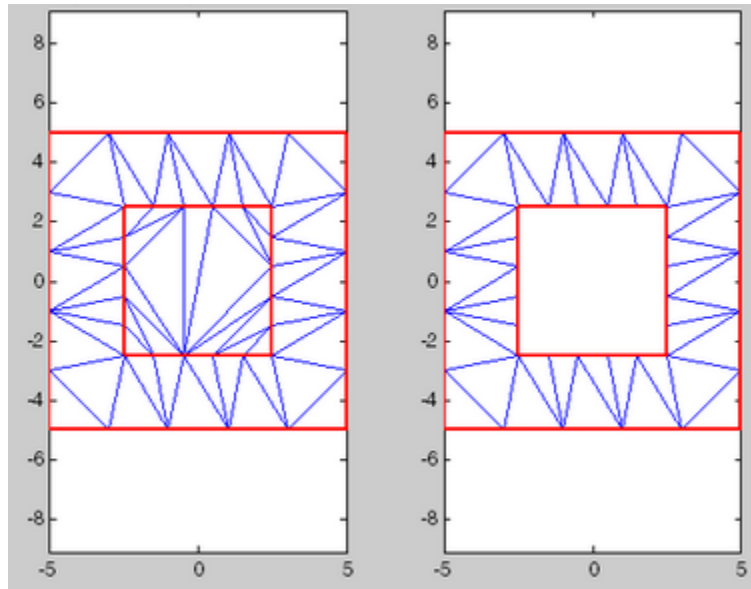

## See Also

[delaunayTriangulation](#) | [triangulation](#) | [isInterior](#)

# ind2rgb

---

**Purpose** Convert indexed image to RGB image

**Syntax** `RGB = ind2rgb(X,map)`

**Description** `RGB = ind2rgb(X,map)` converts the indexed image, `X`, and the corresponding colormap, `map`, to the truecolor image, `RGB`. The indexed image, `X`, is an `m`-by-`n` array of integers. The colormap, `map`, is a three-column array of values in the range `[0,1]`. Each row of `map` is a three-element RGB triplet that specifies the red, green, and blue components of a single color of the colormap.

- If you specify `X` as an array of class `uint8` or `uint16`, then the value `0` corresponds to the first color in the colormap.
- If you specify `X` as an array of class `single` or `double`, then the value `1` corresponds to the first color in the colormap.

The truecolor image output, `RGB`, is an `m`-by-`n`-by-3 array. For more information on image types, see “Image Types”.

**Class Support** `X` can be of class `uint8`, `uint16`, `single`, or `double`. `RGB` is an `m`-by-`n`-by-3 array of class `double`.

**See Also** `image` | `imread`

**Purpose** Subscripts from linear index

**Syntax** `[I,J] = ind2sub(siz,IND)`  
`[I1,I2,I3,...,In] = ind2sub(siz,IND)`

**Description** The `ind2sub` command determines the equivalent subscript values corresponding to a single index into an array.

`[I,J] = ind2sub(siz,IND)` returns the matrices `I` and `J` containing the equivalent row and column subscripts corresponding to each linear index in the matrix `IND` for a matrix of size `siz`. `siz` is a vector with `ndim(A)` elements (in this case, 2), where `siz(1)` is the number of rows and `siz(2)` is the number of columns.

---

**Note** For matrices, `[I,J] = ind2sub(size(A),find(A>5))` returns the same values as `[I,J] = find(A>5)`.

---

`[I1,I2,I3,...,In] = ind2sub(siz,IND)` returns `n` subscript arrays `I1,I2,...,In` containing the equivalent multidimensional array subscripts equivalent to `IND` for an array of size `siz`. `siz` is an `n`-element vector that specifies the size of each array dimension.

The `IND` input can be `single`, `double`, or any integer type. The outputs are always of class `double`.

## Examples

### Example 1 – Two-Dimensional Matrices

The mapping from linear indexes to subscript equivalents for a 3-by-3 matrix is

# ind2sub

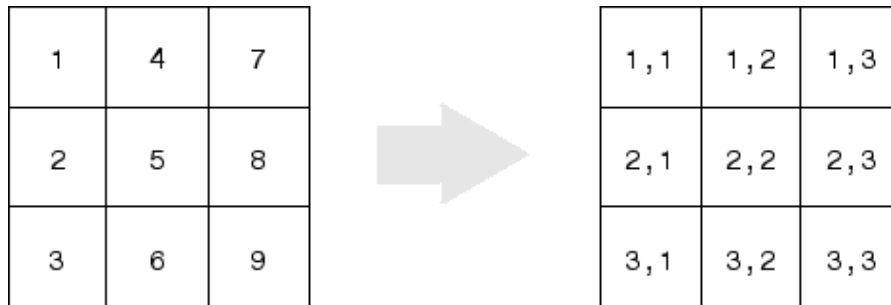

This code determines the row and column subscripts in a 3-by-3 matrix, of elements with linear indices 3, 4, 5, 6.

```
IND = [3 4 5 6]
s = [3,3];
[I,J] = ind2sub(s,IND)
```

```
I =
 3 1 2 3
```

```
J =
 1 2 2 2
```

## Example 2 – Three-Dimensional Matrices

The mapping from linear indexes to subscript equivalents for a 2-by-2-by-2 array is

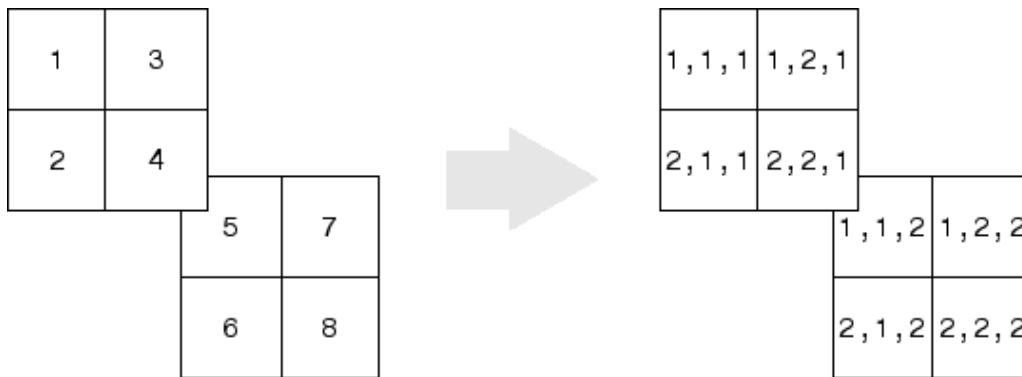

This code determines the subscript equivalents in a 2-by-2-by-2 array, of elements whose linear indices 3, 4, 5, 6 are specified in the IND matrix.

```
IND = [3 4;5 6];
s = [2,2,2];
[I,J,K] = ind2sub(s,IND)
```

```
I =
 1 2
 1 2
```

```
J =
 2 2
 1 1
```

```
K =
 1 1
 2 2
```

### Example 3 – Effects of Returning Fewer Outputs

When calling `ind2sub` for an N-dimensional matrix, you would typically supply N output arguments in the call: one for each dimension of the matrix. This example shows what happens when you return three, two, and one output when calling `ind2sub` on a 3-dimensional matrix.

# ind2sub

---

The matrix is 2-by-2-by-2 and the linear indices are 1 through 8:

```
dims = [2 2 2];
indices = [1 2 3 4 5 6 7 8];
```

The 3-output call to `ind2sub` returns the expected subscripts for the 2-by-2-by-2 matrix:

```
[rowsub colsub pagsub] = ind2sub(dims, indices)
rowsub =
 1 2 1 2 1 2 1 2
colsub =
 1 1 2 2 1 1 2 2
pagsub =
 1 1 1 1 2 2 2 2
```

If you specify only two outputs (row and column), `ind2sub` still returns a subscript for each specified index, but drops the third dimension from the matrix, returning subscripts for a 2-dimensional, 2-by-4 matrix instead:

```
[rowsub colsub] = ind2sub(dims, indices)
rowsub =
 1 2 1 2 1 2 1 2
colsub =
 1 1 2 2 3 3 4 4
```

If you specify one output (row), `ind2sub` drops both the second and third dimensions from the matrix, and returns subscripts for a 1-dimensional, 1-by-8 matrix instead:

```
[rowsub] = ind2sub(dims, indices)
rowsub =
 1 2 3 4 5 6 7 8
```

## See Also

[find](#) | [size](#) | [sub2ind](#)



**Purpose**

Infinity

**Syntax**

```
Inf
I = Inf(n)
I = Inf(sz1, ..., szN)
I = Inf(sz)

I = Inf(classname)
I = Inf(n, classname)
I = Inf(sz1, ..., szN, classname)
I = Inf(sz, classname)

I = Inf('like', p)
I = Inf(n, 'like', p)
I = Inf(sz1, ..., szN, 'like', p)
I = Inf(sz, 'like', p)
```

**Description**

Inf returns the IEEE arithmetic representation for positive infinity. Infinity values result from operations like division by zero and overflow, which lead to results too large to represent as conventional floating-point values.

`I = Inf(n)` is an n-by-n matrix of Inf values.

`I = Inf(sz1, ..., szN)` is a sz1-by-...-by-szN array of Inf values where sz1, ..., szN indicates the size of each dimension. For example, `Inf(3,4)` returns a 3-by-4 array of Inf values.

`I = Inf(sz)` is an array of Inf values where the size vector, sz, defines `size(I)`. For example, `Inf([3,4])` returns a 3-by-4 array of Inf values.

# Inf

---

---

**Note** The size inputs  $sz_1, \dots, sz_N$ , as well as the elements of the size vector  $sz$ , should be nonnegative integers. Negative integers are treated as 0.

---

$I = \text{Inf}(\text{classname})$  returns an Inf value where the string, `classname`, specifies the data type. `classname` can be either 'single' or 'double'.

$I = \text{Inf}(n, \text{classname})$  returns an n-by-n array of Inf values of data type `classname`.

$I = \text{Inf}(sz_1, \dots, sz_N, \text{classname})$  returns a  $sz_1$ -by-...-by- $sz_N$  array of Inf values of data type `classname`.

$I = \text{Inf}(sz, \text{classname})$  returns an array of Inf values where the size vector, `sz`, defines `size(I)` and `classname` defines `class(I)`.

$I = \text{Inf}(\text{'like'}, p)$  returns an array of Infs of the same data type, sparsity, and complexity (real or complex) as the numeric variable, `p`.

$I = \text{Inf}(n, \text{'like'}, p)$  returns an n-by-n array of Inf values like `p`.

$I = \text{Inf}(sz_1, \dots, sz_N, \text{'like'}, p)$  returns a  $sz_1$ -by-...-by- $sz_N$  array of Inf values like `p`.

$I = \text{Inf}(sz, \text{'like'}, p)$  returns an array of Inf values like `p` where the size vector, `sz`, defines `size(I)`.

## Examples

$1/0$ ,  $1.e1000$ ,  $2^{2000}$ , and  $\exp(1000)$  all produce Inf.

$\log(0)$  produces -Inf.

Inf-Inf and Inf/Inf both produce NaN (Not-a-Number).

**See Also**      `nan` | `isinf` | `isfinite` | `isfloat`

**Concepts**      • “Class Support for Array-Creation Functions”

# inferiorto

---

**Purpose** Specify inferior class relationship

**Syntax** `inferiorto('class1','class2',...)`

**Description** `inferiorto('class1','class2',...)` establishes that the class invoking this function in its constructor has lower precedence than the classes in the argument list. MATLAB uses this precedence to determine which method or function MATLAB calls in any given situation.

Use this function only from a constructor that calls the `class` function to create objects (classes defined before MATLAB 7.6).

**Examples** Specify class precedence.

Suppose `a` is an object of class `class_a`, `b` is an object of class `class_b`, and `c` is an object of class `class_c`. Suppose the constructor method of `class_c` contains the statement:

```
inferiorto('class_a')
```

This function call establishes `class_a` as taking precedence over `class_c` for function dispatching. Therefore, either of the following two statements:

```
e = fun(a,c);
e = fun(c,a);
```

Invoke `class_a`/fun.

If you call a function with two objects having an unspecified relationship, the two objects have equal precedence. In this case, MATLAB calls the method of the left-most object. So `fun(b, c)` calls `class_b`/fun, while `fun(c, b)` calls `class_c`/fun.

**See Also** `superiorto`

**Purpose** Information about contacting MathWorks

---

**Note** info will be removed in a future release.

---

**Syntax** info

**Description** info displays in the Command Window, information about contacting MathWorks.

**See Also** help | version

# inline

---

|                      |                                                                                                                                                                                                                                                                                                                                                                                                                                                                                                                                                                                                                                                                                                                                                                                                                                                                                                                                                                                                 |
|----------------------|-------------------------------------------------------------------------------------------------------------------------------------------------------------------------------------------------------------------------------------------------------------------------------------------------------------------------------------------------------------------------------------------------------------------------------------------------------------------------------------------------------------------------------------------------------------------------------------------------------------------------------------------------------------------------------------------------------------------------------------------------------------------------------------------------------------------------------------------------------------------------------------------------------------------------------------------------------------------------------------------------|
| <b>Purpose</b>       | Construct inline object                                                                                                                                                                                                                                                                                                                                                                                                                                                                                                                                                                                                                                                                                                                                                                                                                                                                                                                                                                         |
| <b>Compatibility</b> | <code>inline</code> will be removed in a future release. Use “Anonymous Functions” instead.                                                                                                                                                                                                                                                                                                                                                                                                                                                                                                                                                                                                                                                                                                                                                                                                                                                                                                     |
| <b>Syntax</b>        | <code>inline(expr)</code><br><code>inline(expr, arg1, arg2, ...)</code><br><code>inline(expr, n)</code>                                                                                                                                                                                                                                                                                                                                                                                                                                                                                                                                                                                                                                                                                                                                                                                                                                                                                         |
| <b>Description</b>   | <p><code>inline(expr)</code> constructs an inline function object from the MATLAB expression contained in the string <code>expr</code>. The input argument to the inline function is automatically determined by searching <code>expr</code> for an isolated lower case alphabetic character, other than <code>i</code> or <code>j</code>, that is not part of a word formed from several alphabetic characters. If no such character exists, <code>x</code> is used. If the character is not unique, the one closest to <code>x</code> is used. If two characters are found, the one later in the alphabet is chosen.</p> <p><code>inline(expr, arg1, arg2, ...)</code> constructs an inline function whose input arguments are specified by the strings <code>arg1, arg2, ...</code>. Multicharacter symbol names may be used.</p> <p><code>inline(expr, n)</code> where <code>n</code> is a scalar, constructs an inline function whose input arguments are <code>x, P1, P2, ...</code>.</p> |
| <b>Tips</b>          | <p>Three commands related to <code>inline</code> allow you to examine an inline function object and determine how it was created.</p> <p><code>char(fun)</code> converts the inline function into a character array. This is identical to <code>formula(fun)</code>.</p> <p><code>argnames(fun)</code> returns the names of the input arguments of the inline object <code>fun</code> as a cell array of strings.</p> <p><code>formula(fun)</code> returns the formula for the inline object <code>fun</code>.</p> <p>A fourth command <code>vectorize(fun)</code> inserts a <code>.</code> before any <code>^</code>, <code>*</code> or <code>/</code> in the formula for <code>fun</code>. The result is a vectorized version of the inline function.</p>                                                                                                                                                                                                                                     |

## Examples

### Example 1

This example creates a simple inline function to square a number.

```
g = inline('t^2')
g =
```

```
 Inline function:
 g(t) = t^2
```

You can convert the result to a string using the char function.

```
char(g)
```

```
ans =
```

```
t^2
```

### Example 2

This example creates an inline function to represent the formula  $f = 3\sin(2x^2)$ . The resulting inline function can be evaluated with the argnames and formula functions.

```
f = inline('3*sin(2*x.^2)')
```

```
f =
```

```
 Inline function:
 f(x) = 3*sin(2*x.^2)
```

```
argnames(f)
```

```
ans =
```

```
 'x'
```

```
formula(f)
```

```
ans =
```

```
3*sin(2*x.^2)
```

### Example 3

This call to `inline` defines the function `f` to be dependent on two variables, `alpha` and `x`:

```
f = inline('sin(alpha*x)')

f =
 Inline function:
 f(alpha,x) = sin(alpha*x)
```

If `inline` does not return the desired function variables or if the function variables are in the wrong order, you can specify the desired variables explicitly with the `inline` argument list.

```
g = inline('sin(alpha*x)', 'x', 'alpha')

g =
 Inline function:
 g(x,alpha) = sin(alpha*x)
```



**Purpose**

Names of functions, MEX-files, classes in memory

**Syntax**

```
M = inmem
[M,X] = inmem
[M,X,C] = inmem
[...] = inmem('-completenames')
```

**Description**

`M = inmem` returns a cell array of strings containing the names of the functions that are currently loaded.

`[M,X] = inmem` returns an additional cell array `X` containing the names of the MEX-files that are currently loaded.

`[M,X,C] = inmem` also returns a cell array `C` containing the names of the classes that are currently loaded.

`[...] = inmem('-completenames')` returns not only the names of the currently loaded function and MEX-files, but the path and filename extension for each as well. No additional information is returned for loaded classes.

**Examples****Functions in Memory**

List the functions that remain in memory after calling the `magic` function.

```
clear all
magic(10);

M = inmem

M =
 'workspacefunc'
 'magic'
```

The function list includes `magic` and additional functions that are in memory in your current session.

## MEX-Files in Memory

Call a sample MEX-function named `arrayProduct`, and then verify that the MEX-function is in memory. You must have a supported C compiler installed on your system to run this example.

```
clear all
sampleFolder = fullfile(matlabroot,'extern','examples','mex');
addpath(sampleFolder);
mex arrayProduct.c
```

```
s = 5;
A = [1.5, 2, 9];
B = arrayProduct(s,A);
```

```
[M,X] = inmem('-completenames');
X
```

```
X =
 'matlabroot\extern\examples\mex\arrayProduct.mexw64'
```

## See Also

```
clear
```

**Purpose**

Inner join between two tables

**Syntax**

```
C = innerjoin(A,B)
C = innerjoin(A,B,Name,Value)
[C,ia,ib] = innerjoin(___)
```

**Description**

`C = innerjoin(A,B)` creates the table, `C`, as the inner join between the tables `A` and `B` by matching up rows using all the variables with the same name as key variables.

The inner join retains only the rows that match between `A` and `B` with respect to the key variables. `C` contains all nonkey variables from `A` and `B`.

`C = innerjoin(A,B,Name,Value)` performs the inner-join operation with additional options specified by one or more `Name,Value` pair arguments.

For example, you can specify the variables to use as key variables.

`[C,ia,ib] = innerjoin( ___ )` also returns index vectors, `ia` and `ib` indicating the correspondence between rows in `C` and those in `A` and `B` respectively. You can use this syntax with any of the input arguments in the previous syntaxes.

**Input Arguments****A,B - Input tables**

tables

Input tables, specified as tables.

**Name-Value Pair Arguments**

Specify optional comma-separated pairs of `Name,Value` arguments. `Name` is the argument name and `Value` is the corresponding value. `Name` must appear inside single quotes ( ' ' ). You can specify several name and value pair arguments in any order as `Name1,Value1,...,NameN,ValueN`.

**Example:** 'Keys', 2 uses the second variable in A and the second variable in B as key variables.

## **'Keys' - Variables to use as keys**

positive integer | vector of positive integers | variable name | cell array of variable names | logical vector

Variables to use as keys, specified as the comma-separated pair consisting of 'Keys' and a positive integer, vector of positive integers, variable name, cell array of variable names, or logical vector.

You cannot use the 'Keys' name-value pair argument with the 'LeftKeys' and 'RightKeys' name-value pair arguments.

**Example:** 'Keys', [1 3] uses the first and third variables in A and B as a key variables.

## **'LeftKeys' - Variables to use as keys in A**

positive integer | vector of positive integers | variable name | cell array of variable names | logical vector

Variables to use as keys in A, specified as the comma-separated pair consisting of 'LeftKeys' and a positive integer, vector of positive integers, variable name, cell array of variable names, or logical vector.

You must use the 'LeftKeys' name-value pair argument in conjunction with the 'RightKeys' name-value pair argument. 'LeftKeys' and 'RightKeys' both must specify the same number of key variables. `innerjoin` pairs key values based on their order.

**Example:** 'LeftKeys', 1 uses only the first variable in A as a key variable.

## **'RightKeys' - Variables to use as keys in B**

positive integer | vector of positive integers | variable name | cell array of variable names | logical vector

Variables to use as keys in B, specified as the comma-separated pair consisting of 'RightKeys' and a positive integer, vector of positive integers, variable name, cell array of variable names, or logical vector.

You must use the 'RightKeys' name-value pair argument in conjunction with the 'LeftKeys' name-value pair argument. 'LeftKeys' and 'RightKeys' both must specify the same number of key variables. innerjoin pairs key values based on their order.

**Example:** 'RightKeys',3 uses only the third variable in B as a key variable.

### 'LeftVariables' - Variables from A to include in C

positive integer | vector of positive integers | variable name | cell array containing one or more variable names | logical vector

Variables from A to include in C, specified as the comma-separated pair consisting of 'LeftVariables' and a positive integer, vector of positive integers, variable name, cell array of variable names, or logical vector.

You can use 'LeftVariables' to include or exclude key variables, as well as nonkey variables from the output, C.

By default, innerjoin includes all variables from A.

### 'RightVariables' - Variables from B to include in C

positive integer | vector of positive integers | variable name | cell array containing one or more variable names | logical vector

Variables from B to include in C, specified as the comma-separated pair consisting of 'RightVariables' and a positive integer, vector of positive integers, variable name, cell array of variable names, or logical vector.

You can use 'RightVariables' to include or exclude key variables, as well as nonkey variables from the output, C.

By default, innerjoin includes all the variables from B except the key variables.

## Output Arguments

### C - Inner join from A and B

table

Inner join from A and B, returned as a table. The output table, C, contains one row for each pair of rows in tables A and B that share the same combination of values in the key variables. If A and B contain

# innerjoin

---

variables with the same name, `innerjoin` adds a unique suffix to the corresponding variable names in C.

In general, if there are  $m$  rows in table A and  $n$  rows in table B that all contain the same combination of values in the key variables, table C contains  $m*n$  rows for that combination.

C is sorted by the values in the key variables and contains the horizontal concatenation of  $A(ia, LeftVars)$  and  $B(ib, RightVars)$ . By default, `LeftVars` consists of all the variables of A, and `RightVars` consists of all the nonkey variables from B. Otherwise, `LeftVars` consists of the variables specified by the 'LeftVariables' name-value pair argument, and `RightVars` is the variables specified by the 'RightVariables' name-value pair argument.

You can store additional metadata such as descriptions, variable units, variable names, and row names in the output table, C. For more information, see [Table Properties](#).

## **ia - Index to A**

column vector

Index to A, returned as a column vector. Each element of `ia` identifies the row in table A that corresponds to that row in the output table, C.

## **ib - Index to B**

column vector

Index to B, returned as a column vector. Each element of `ib` identifies the row in table B that corresponds to that row in the output table, C.

## **Definitions**

### **Key Variable**

Variable used to match and combine data between the input tables, A and B.

## **Examples**

### **Inner-Join Operation of Tables with One Variable in Common**

Create a table, A.

```
A = table([5;12;23;2;6],...
 {'cereal';'pizza';'salmon';'cookies';'pizza'},...
 'VariableNames',{'Age','FavoriteFood'})
```

A =

| Age | FavoriteFood |
|-----|--------------|
| 5   | 'cereal'     |
| 12  | 'pizza'      |
| 23  | 'salmon'     |
| 2   | 'cookies'    |
| 6   | 'pizza'      |

Create a table, B, with one variable in common with A.

```
B = table({'cereal';'cookies';'pizza';'salmon';'cake'},...
 [110;160;140;367;243],...
 {'A-';'D';'B';'B';'C-'},...
 'VariableNames',{'FavoriteFood','Calories','NutritionGrade'})
```

B =

| FavoriteFood | Calories | NutritionGrade |
|--------------|----------|----------------|
| 'cereal'     | 110      | 'A-'           |
| 'cookies'    | 160      | 'D'            |
| 'pizza'      | 140      | 'B'            |
| 'salmon'     | 367      | 'B'            |
| 'cake'       | 243      | 'C-'           |

Use the `innerjoin` function to create a new table, C, with data from tables A and B.

```
C = innerjoin(A,B)
```

C =

| Age | FavoriteFood | Calories | NutritionGrade |
|-----|--------------|----------|----------------|
| 5   | 'cereal'     | 110      | 'A-'           |
| 2   | 'cookies'    | 160      | 'D'            |
| 12  | 'pizza'      | 140      | 'B'            |
| 6   | 'pizza'      | 140      | 'B'            |
| 23  | 'salmon'     | 367      | 'B'            |

Table C is sorted by the key variable, FavoriteFood.

## Inner-Join Operation of Tables and Indices to Values

Create a table, A.

```
A = table({'a' 'b' 'c' 'e' 'h'},[1 2 3 11 17]',...
 'VariableNames',{'Key1' 'Var1'})
```

A =

| Key1 | Var1 |
|------|------|
| 'a'  | 1    |
| 'b'  | 2    |
| 'c'  | 3    |
| 'e'  | 11   |
| 'h'  | 17   |

Create a table, B, with common values in the variable Key1 between tables A and B, but also containing rows with values of Key1 not present in A.

```
B = table({'a' 'b' 'd' 'e'},[4 5 6 7]',...
 'VariableNames',{'Key1' 'Var2'})
```



B =

| Key1 | Var2 |
|------|------|
| 'a'  | 4    |
| 'b'  | 5    |
| 'd'  | 6    |
| 'e'  | 7    |

Use the `innerjoin` function to create a new table, C, with data from tables A and B. Retain only rows whose values in the variable Key1 match.

Also, return index vectors, `ia` and `ib` indicating the correspondence between rows in C and rows in A and B respectively.

```
[C,ia,ib] = innerjoin(A,B)
```

C =

| Key1 | Var1 | Var2 |
|------|------|------|
| 'a'  | 1    | 4    |
| 'b'  | 2    | 5    |
| 'e'  | 11   | 7    |

ia =

1  
2  
4

ib =

# innerjoin

---

```
1
2
4
```

Table C is sorted by the values in the key variable, Key1, and contains the horizontal concatenation of A(ia,:) and B(ib,'Var2').

## Inner-Join Operation of Tables Using Left and Right Keys

Create a table, A.

```
A = table([10;4;2;3;7],[5;4;9;6;1],[10;3;8;8;4])
```

A =

| Var1 | Var2 | Var3 |
|------|------|------|
| 10   | 5    | 10   |
| 4    | 4    | 3    |
| 2    | 9    | 8    |
| 3    | 6    | 8    |
| 7    | 1    | 4    |

Create a table, B, with common values in the second variable as the first variable of table A.

```
B = table([6;1;1;6;8],[2;3;4;5;6])
```

B =

| Var1 | Var2 |
|------|------|
| 6    | 2    |
| 1    | 3    |
| 1    | 4    |
| 6    | 5    |
| 8    | 6    |

Use the `innerjoin` function to create a new table, `C`, with data from tables `A` and `B`. Use the first variable of `A` and the second variable of `B` as key variables.

```
[C,ia,ib] = innerjoin(A,B,'LeftKeys',1,'RightKeys',2)
```

`C =`

| <u>Var1_A</u> | <u>Var2</u> | <u>Var3</u> | <u>Var1_B</u> |
|---------------|-------------|-------------|---------------|
| 2             | 9           | 8           | 6             |
| 3             | 6           | 8           | 1             |
| 4             | 4           | 3           | 1             |

`ia =`

```
3
4
2
```

`ib =`

```
1
2
3
```

Table `C` retains only the rows that match between `A` and `B` with respect to the key variables.

Table `C` contains the horizontal concatenation of `A(ia,:)` and `B(ib,'Var1')`.

## See Also

`join` | `outerjoin`

# inpolygon

---

**Purpose** Points inside polygonal region

**Syntax**  
`IN = inpolygon(X,Y,xv,yv)`  
`[IN ON] = inpolygon(X,Y,xv,yv)`

**Description** `IN = inpolygon(X,Y,xv,yv)` returns a matrix `IN` the same size as `X` and `Y`. Each element of `IN` is assigned the value 1 or 0 depending on whether the point  $(X(p,q), Y(p,q))$  is inside the polygonal region whose vertices are specified by the vectors `xv` and `yv`. In particular:

$IN(p,q) = 1$  If  $(X(p,q), Y(p,q))$  is inside the polygonal region or on the polygon boundary

$IN(p,q) = 0$  If  $(X(p,q), Y(p,q))$  is outside the polygonal region

`[IN ON] = inpolygon(X,Y,xv,yv)` returns a second matrix `ON` the same size as `X` and `Y`. Each element of `ON` is assigned the value 1 or 0 depending on whether the point  $(X(p,q), Y(p,q))$  is on the boundary of the polygonal region whose vertices are specified by the vectors `xv` and `yv`. In particular:

$ON(p,q) = 1$  If  $(X(p,q), Y(p,q))$  is on the polygon boundary

$ON(p,q) = 0$  If  $(X(p,q), Y(p,q))$  is inside or outside the polygon boundary

## Examples

```
L = linspace(0,2.*pi,6); xv = cos(L)';yv = sin(L)';
xv = [xv ; xv(1)]; yv = [yv ; yv(1)];
x = randn(250,1); y = randn(250,1);
in = inpolygon(x,y,xv,yv);
plot(xv,yv,x(in),y(in), 'r+',x(~in),y(~in), 'bo')
```

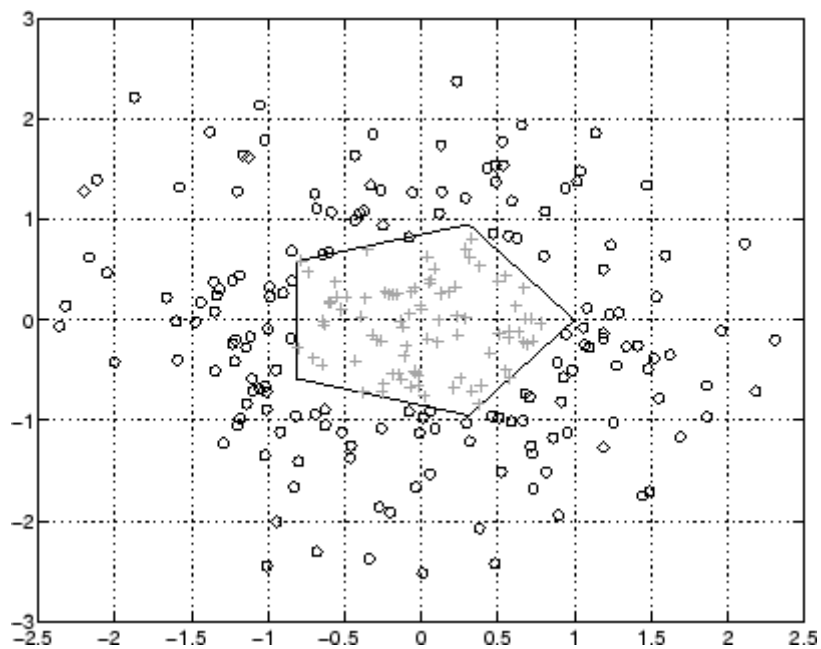

# input

---

**Purpose** Request user input

**Syntax**  
`result = input(prompt)`  
`str = input(prompt,'s')`

**Description** `result = input(prompt)` displays the `prompt` string on the screen, waits for input from the keyboard, evaluates any expressions in the input, and returns the result. To evaluate expressions, the `input` function can use variables in the current workspace.

- If you press the **Return** key without entering anything, then `input` returns an empty matrix.
- If you enter an invalid expression at the prompt, then MATLAB displays the relevant error message, and then redisplay the prompt.

`str = input(prompt,'s')` returns the entered text as a MATLAB string, without evaluating expressions.

## Input Arguments

**prompt - Query that requests input**  
string

Query that requests input, specified as a string.

To create a prompt that spans several lines, use `'\n'` to indicate each new line. To include a backslash (`'\'`) in the prompt, use `'\\'`.

**Data Types**  
char

## Output Arguments

**result - Result calculated from input**  
array

Result calculated from input, returned as an array. The type and dimensions of the array depend upon the response to the prompt.

**str - Exact text of input**  
string

Exact text of input, returned as a string.

## Data Types

char

## Examples

### Numeric or Evaluated Input

Request a numeric input, and then multiply the input by 10.

```
prompt = 'What is the original value? ';
result = input(prompt)
largernum = result * 10
```

At the prompt, enter a numeric value or array, such as 42.

```
result =
 42

largernum =
 420
```

The input function also accepts expressions. For example, rerun the code.

```
prompt = 'What is the original value? ';
result = input(prompt)
largernum = result * 10
```

At the prompt, enter magic(3).

```
result =
 8 1 6
 3 5 7
 4 9 2

largernum =
 80 10 60
 30 50 70
 40 90 20
```

# input

---

The expression does not need to return a numeric result. For example:

```
prompt = 'What color is the sun? ';
result = input(prompt)
```

At the prompt, type `upper('yellow')`.

```
result =
YELLOW
```

## Unprocessed Text Input

Request a simple text response that requires no evaluation.

```
prompt = 'Do you want more? Y/N [Y]: ';
str = input(prompt,'s');
if isempty(str)
 str = 'Y';
end
```

The `input` function returns the text exactly as typed. If the input is empty, this code assigns a default value, 'Y', to the output string, `str`.

## See Also

`keyboard` | `inputdlg` | `menu` | `ginput` | `uicontrol`



**Purpose**

Create and open input dialog box

**Syntax**

```
answer = inputdlg(prompt)
answer = inputdlg(prompt,dlg_title)
answer = inputdlg(prompt,dlg_title,num_lines)
answer = inputdlg(prompt,dlg_title,num_lines,defAns)
answer = inputdlg(prompt,dlg_title,num_lines,defAns,options)
```

**Description**

`answer = inputdlg(prompt)` creates a modal dialog box and returns user input for multiple prompts in the cell array. `prompt` is a cell array containing prompt strings.

---

**Note** A modal dialog box prevents the user from interacting with other windows before responding. For more information, see `WindowState` in the MATLAB Figure Properties.

---

`answer = inputdlg(prompt,dlg_title)` `dlg_title` specifies a title for the dialog box.

`answer = inputdlg(prompt,dlg_title,num_lines)` `num_lines` specifies the number of lines for each user-entered value. `num_lines` can be a scalar, column vector, or a  $m \times 2$  array.

- If `num_lines` is a scalar, it applies to all prompts.
- If `num_lines` is a column vector, each element specifies the number of lines of input for a prompt.
- If `num_lines` is an array, it must be size  $m$ -by-2, where  $m$  is the number of prompts on the dialog box. Each row refers to a prompt. The first column specifies the number of lines of input for a prompt. The second column specifies the width of the field in characters.

`answer = inputdlg(prompt,dlg_title,num_lines,defAns)` `defAns` specifies the default value to display for each prompt. `defAns` must contain the same number of elements as `prompt` and all elements must be strings.

# inputdlg

---

```
answer =
inputdlg(prompt,dlg_title,num_lines,defAns,options) If
options is the string 'on', the dialog is made resizable in the
horizontal direction. If options is a structure, the fields shown in
the following table are recognized:
```

| Field       | Description                                                                                                  |
|-------------|--------------------------------------------------------------------------------------------------------------|
| Resize      | Can be 'on' or 'off' (default). If 'on', the window is resizable horizontally.                               |
| WindowStyle | Can be either 'normal' or 'modal' (default).                                                                 |
| Interpreter | Can be either 'none' (default) or 'tex'. If the value is 'tex', the prompt strings are rendered using LaTeX. |

If the user clicks the **Cancel** button to close an `inputdlg` box, the dialog returns an empty cell array:

```
answer =
 {}
```

## Tips

`inputdlg` uses the `uiwait` function to suspend execution until the user responds.

The returned variable `answer` is a cell array containing strings, one string per text entry field, starting from the top of the dialog box.

To convert a member of the cell array to a number, use `str2num`. To do this, you can add the following code to the end of any of the examples below:

```
% Use curly bracket for subscript
[val status] = str2num(answer{1});
if ~status
 % Handle empty value returned
 % for unsuccessful conversion
 % ...
end
% val is a scalar or matrix converted from the first input
```

Users can enter scalar or vector values into `inputdlg` fields; `str2num` converts space- and comma-delimited strings into row vectors, and semicolon-delimited strings into column vectors. For example, if `answer{1}` contains `'1 2 3;4 -5 6+7i'`, the conversion produces:

```
val = str2num(answer{1})
val =
 1.0000 2.0000 3.0000
 4.0000 -5.0000 6.0000 + 7.0000i
```

## Examples

### Example 1

Create a dialog box to input an integer and colormap name. Allow one line for each value.

```
prompt = {'Enter matrix size:', 'Enter colormap name:'};
dlg_title = 'Input';
num_lines = 1;
def = {'20', 'hsv'};
answer = inputdlg(prompt,dlg_title,num_lines,def);
```

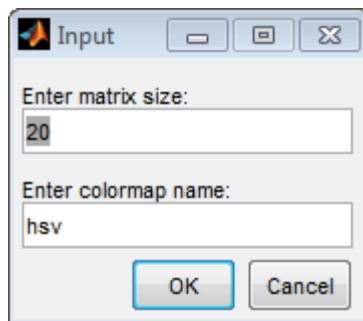

### Example 2

Create a dialog box named to accept comma-separated numbers. MATLAB stores accepts the input as a string, so convert the string to numbers using `str2num`.

```
x = inputdlg('Enter space-separated numbers:', ...
```

# inputdlg

---

```
'Sample', [1 50]);
data = str2num(x{:});
```

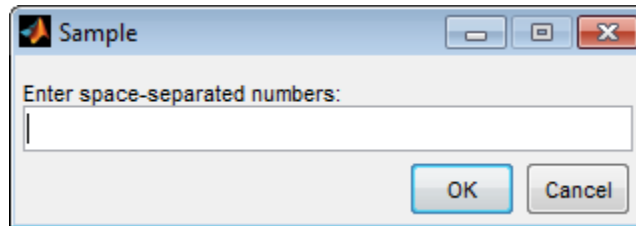

## Example 3

Create a dialog box to display input fields of different widths.

```
x = inputdlg({'Name','Telephone','Account'},...
 'Customer', [1 50; 1 12; 1 7]);
```

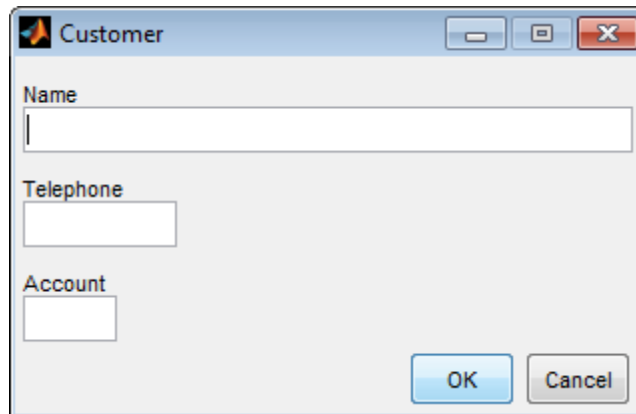

## Example 4

Create a dialog box using the default options. Then, use the options to make it resizable and not modal, and to interpret the text using LaTeX.

```
prompt={'Enter the matrix size for x^2:',...
 'Enter the colormap name:'};
```

```
name='Input for Peaks function';
numlines=1;
defaultanswer={'20','hsv'};
answer=inputdlg(prompt,name,numlines,defaultanswer);
```

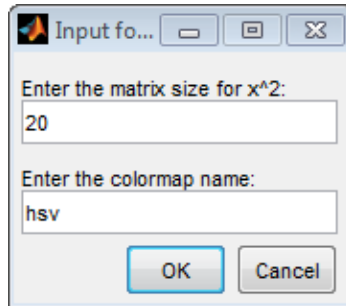

```
options.Resize='on';
options.WindowStyle='normal';
options.Interpreter='tex';
answer=inputdlg(prompt,name,numlines,...
 defaultanswer,options);
```

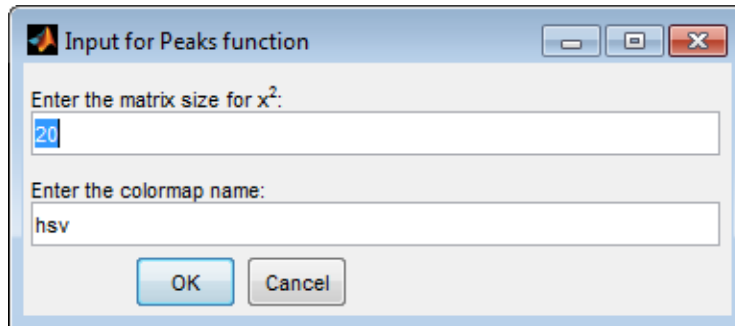

## See Also

dialog | errordlg | helpdlg | listdlg | msgbox | questdlg |  
warndlg | input | figure | str2num | uiwait | uiresume

# inputname

---

**Purpose** Variable name of function input

**Syntax** `inputname(argnum)`

**Description** This command can be used only inside the body of a function. `inputname(argnum)` returns the workspace variable name corresponding to the argument number *argnum*. If the input argument has no name (for example, if it is an expression instead of a variable), the `inputname` command returns the empty string ('').

**Examples** Suppose the function `myfun.m` is defined as

```
function c = myfun(a,b)
fprintf('First calling variable is "%s"\n.', inputname(1))
```

Then

```
x = 5; y = 3; myfun(x,y)
```

produces

```
First calling variable is "x".
```

But

```
myfun(pi+1, pi-1)
```

produces

```
First calling variable is "".
```

**See Also** `nargin` | `nargout` | `narginchk`

**Purpose** Parse function inputs

**Description** The `inputParser` object allows you to manage inputs to a function by creating an input scheme. To check the input, you can define validation functions for required arguments, optional arguments, and name-value pair arguments. Optionally, you can set properties to adjust the parsing behavior, such as handling case sensitivity, structure array inputs, and inputs that are not in the input scheme.

After calling the `parse` method to parse the inputs, the `inputParser` saves names and values of inputs that match the input scheme (stored in `Results`), names of inputs that are not passed to the function and, therefore, are assigned default values (stored in `UsingDefaults`), and names and values of inputs that do not match the input scheme (stored in `Unmatched`).

**Construction** `p = inputParser` creates `inputParser` object `p`.

**Properties** **CaseSensitive**

Scalar logical value that indicates whether to match case when checking argument names.

Possible values:

|                        |                                                   |
|------------------------|---------------------------------------------------|
| <code>false</code> (0) | Names are not sensitive to case: 'a' matches 'A'. |
| <code>true</code> (1)  | Names are case sensitive: 'a' does not match 'A'. |

**Default:** `false`

**FunctionName**

String that specifies the name of the function to include in error messages. By specifying the `FunctionName`, the `parse` method of the `inputParser` will throw error messages as if it were that

function. This allows the error to be attributed to the correct function and allows easy access to function documentation through the error message.

**Default:** The default value is an empty string, ''.

## **KeepUnmatched**

Scalar logical value that indicates how to handle parameter name and value inputs that are not in the input scheme.

Possible values:

- |           |                                                                                                                                                                 |
|-----------|-----------------------------------------------------------------------------------------------------------------------------------------------------------------|
| false (0) | Throw an error whenever inputs are not in the scheme.                                                                                                           |
| true (1)  | Store the parameter names and values of unmatched inputs in the <code>Unmatched</code> property of the <code>inputParser</code> object, and suppress the error. |

**Default:** false

## **PartialMatching**

Scalar logical value that indicates whether partial matching of parameter names will be accepted. Partial parameter matching is supported by the `addParameter` method. If the value of `StructExpand` is true, then `PartialMatching` is not supported for structure field names corresponding to input parameter names.

Possible values:



|           |                                                                                                                                                                                                     |
|-----------|-----------------------------------------------------------------------------------------------------------------------------------------------------------------------------------------------------|
| true (1)  | Inputs that are leading substrings of parameter names will be accepted and the value matched to that parameter. If there are multiple possible matches to the input string, MATLAB throws an error. |
| false (0) | Input names are required to match a parameter name exactly (with respect to the CaseSensitive property.)                                                                                            |

**Default:** true

## **StructExpand**

Scalar logical value that specifies whether to interpret a structure array as a single input or as a set of parameter name and value pairs.

|           |                                                                                                 |
|-----------|-------------------------------------------------------------------------------------------------|
| true (1)  | Expand structures into separate inputs. Each field name corresponds to an input parameter name. |
| false (0) | Regard a structure array as a single input argument.                                            |

**Default:** true

## **Read Only Properties**

### **Parameters**

Cell array of strings that contains the names of arguments currently defined in the input scheme.

Each method that adds an input argument to the scheme (addRequired, addOptional, addParameter) updates the Parameters property.

### **Results**

# inputParser

---

Structure containing names and values of inputs that match the function input scheme, populated by the `parse` method.

Each field of the `Results` structure corresponds to the name of an input.

## Unmatched

Structure array containing the names and values of inputs that do not match the function input scheme, populated by the `parse` method.

If `KeepUnmatched` is `false` (default) or all inputs match the scheme, then `Unmatched` is a 1-by-1 structure with no fields. Otherwise, each field of the structure corresponds to the name of an input that did not match the scheme.

## UsingDefaults

Cell array containing the names of inputs not passed explicitly to the function and assigned default values, populated by the `parse` method.

## Methods

|                            |                                                                                |
|----------------------------|--------------------------------------------------------------------------------|
| <code>addOptional</code>   | Add optional positional argument to input parser scheme                        |
| <code>addParameter</code>  | Add optional parameter name-value pair argument to input parser scheme         |
| <code>addParamValue</code> | (Not recommended) Add parameter name and value argument to Input Parser scheme |
| <code>addRequired</code>   | Add required positional argument to input parser scheme                        |
| <code>createCopy</code>    | Create copy of <code>inputParser</code> object (to be removed)                 |
| <code>parse</code>         | Parse function inputs                                                          |

You can define your scheme by calling `addRequired`, `addOptional`, and `addParameter` in any order, but when you call your function that uses the input parser, you should pass in required inputs first, followed by any optional positional inputs, and, finally, any name-value pairs.

## Copy Semantics

Handle. To learn how handle classes affect copy operations, see [Copying Objects](#) in the MATLAB documentation.

The copy method creates another scheme with the same properties as an existing `inputParser` object:

```
pNew = copy(pOld);
```

## Examples

### Input Validation

Check the validity of required and optional function inputs.

Create a custom function with required and optional inputs in the file `findArea.m`.

```
function a = findArea(width,varargin)
 p = inputParser;
 defaultHeight = 1;
 defaultUnits = 'inches';
 defaultShape = 'rectangle';
 expectedShapes = {'square','rectangle','parallelogram'};

 addRequired(p,'width',@isnumeric);
 addOptional(p,'height',defaultHeight,@isnumeric);
 addParameter(p,'units',defaultUnits);
 addParameter(p,'shape',defaultShape,...
 @(x) any(validatestring(x,expectedShapes)));

 parse(p,width,varargin{:});
 a = p.Results.width .* p.Results.height;
```

The input parser checks whether `width` and `height` are numeric, and whether the shape matches a string in cell array `expectedShapes`. @

# inputParser

---

indicates a function handle, and the syntax @(x) creates an anonymous function with input x.

Call the function with inputs that do not match the scheme. For example, specify a nonnumeric value for the width input:

```
findArea('text')
```

```
Error using findArea (line 14)
The value of 'width' is invalid. It must satisfy the function: isnumeric.
```

Specify an unsupported value for shape:

```
findArea(4,'shape','circle')
```

```
Error using findArea (line 14)
The value of 'shape' is invalid. Expected input to match one of these strings:
```

```
square, rectangle, parallelogram
```

```
The input, 'circle', did not match any of the valid strings.
```

## Extra Parameter Value Inputs

Store parameter name and value inputs that are not in the input scheme instead of throwing an error.

```
default = 0;
value = 1;

p = inputParser;
p.KeepUnmatched = true;
addOptional(p,'expectedInputName',default);
parse(p,'extraInput',value);
```

View the unmatched parameter name and value:

```
p.Unmatched
```

```
ans =

 extraInput: 1
```

## Case Sensitivity

Enforce case sensitivity when checking function inputs.

```
p = inputParser;
p.CaseSensitive = true;
defaultValue = 0;
addParameter(p, 'InputName', defaultValue);

parse(p, 'inputname', 10)
```

'inputname' is not a recognized parameter. For a list of valid name-value pair arguments, see the do

## Structure Array Inputs

Parse structure array inputs with the `StructExpand` property set to true (default) or false.

Expand a structure array input into parameter name and value pairs using the default true value of the `StructExpand` property.

```
s.input1 = 10;
s.input2 = 20;
default = 0;

p = inputParser;
addParameter(p, 'input1', default);
addParameter(p, 'input2', default);
parse(p, s);

p.Results
```

# inputParser

---

```
ans =

 input1: 10
 input2: 20
```

Explicitly specifying a parameter name and value pair overrides values in the structure.

```
parse(p,s,'input2',300);
p.Results
```

```
ans =

 input1: 10
 input2: 300
```

Accept a structure array input as a single argument by setting the StructExpand property to false.

```
s2.first = 1;
s2.random = rand(3,4,2);
s2.mytext = 'some text';

p = inputParser;
p.StructExpand = false;
addRequired(p,'structInput');
parse(p,s2);

results = p.Results
fieldList = fieldnames(p.Results.structInput)

results =
```

```

structInput: [1x1 struct]

fieldList =

 'first'
 'random'
 'mytext'

```

### Parse Inputs Using validateattributes

Create a function that parses information about people and, if parsing passes, adds the information to a cell array.

Create a function, `addPerson`, that sets up an `inputParser` scheme using `validateAttributes`. The function should accept the list of people, modify the list if necessary and return the list. Use a persistent `inputParser` to avoid construction of a new object with every function call. If this is the first call to the function, add a titles row to the cell array.

```

function mList = addPerson(mList,varargin)

persistent p
if isempty(p)
 p = inputParser;
 p.FunctionName = 'addPerson';
 addRequired(p,'name',@(x)validateattributes(x',{'char'},...
 {'nonempty'}));
 addRequired(p,'id',@(x)validateattributes(x',{'numeric'},...
 {'nonempty','integer','positive'}));
 addOptional(p,'birthyear',9999,@(x)validateattributes(x,...
 {'numeric'},{'nonempty'}));
 addParameter(p,'nickname','- ',@(x)validateattributes(x,...
 {'char'},{'nonempty'}));
 addParameter(p,'favColor','- ',@(x)validateattributes(x,...
 {'char'},{'nonempty'}));

```

# inputParser

---

```
end

parse(p,varargin{:});

if isempty(mList)
 mList = fieldnames(p.Results)';
end
mList = [mList; struct2cell(p.Results)'];

end
```

Create an empty list, and add a person to it.

```
pList = {};
pList = addPerson(pList,78,'Joe');
```

```
Error using addPerson
The value of 'name' is invalid. Expected input to be one of these types:
```

```
char

Instead its type was double.
Error in addPerson (line 17)
parse(p,mList,name,id,varargin{:});
```

The parsing failed because the function received the inputs in the incorrect order and tried to assign name a value of 78. This entry was not added to pList.

Add several more people to the list.

```
pList = addPerson(pList,'Joe',78);
pList = addPerson(pList,'Mary',3,1942,'favColor','red');
pList = addPerson(pList,'James',182,1970,'nickname','Jimmy')
```

```
pList =

 'birthyear' 'favColor' 'id' 'name' 'nickname'
```



```
[9999] '-' [78] 'Joe' '-'
[1942] 'red' [3] 'Mary' '-'
[1970] '-' [182] 'James' 'Jimmy'
```

## See Also

[validateattributes](#) | [validatestring](#) | [varargin](#) | [narginchk](#) | [nargin](#)

## Concepts

- “Input Parser Validation Functions”

# inspect

---

**Purpose** Open Property Inspector

**Syntax**  
`inspect`  
`inspect(h)`  
`inspect([h1,h2,...])`

**Description** `inspect` creates a separate Property Inspector window to enable the display and modification of the properties of any object you select in the figure window or Layout Editor. If no object is selected, the Property Inspector is blank.

`inspect(h)` creates a Property Inspector window for the object whose handle is `h`.

`inspect([h1,h2,...])` displays properties that objects `h1` and `h2` have in common, or a blank window if there are no such properties; any number of objects can be inspected and edited in this way (for example, handles returned by the `bar` command).

The Property Inspector has the following behaviors:



- Only one Property Inspector window is active at any given time; when you inspect a new object, its properties replace those of the object last inspected.
- When the Property Inspector is open and plot edit mode is on, clicking any object in the figure window displays the properties of that object (or set of objects) in the Property Inspector.
- When you select and inspect two or more objects of different types, the Property Inspector only shows the properties that all objects have in common.
- To change the value of any property, click on the property name shown at the left side of the window, and then enter the new value in the field at the right.

The Property Inspector provides two different views:

- List view — properties are ordered alphabetically (default); this is the only view available for annotation objects.

- Group view — properties are grouped under classified headings (Handle Graphics objects only)

To view alphabetically, click the “AZ” Icon  in the Property Inspector toolbar. To see properties in groups, click

the “++” icon . When properties are grouped, the “-” and “+” icons are enabled; click  to expand all categories and click  to collapse all categories. You can also expand and collapse individual categories by clicking on the “+” next to the category name. Some properties expand and collapse

---

**Notes** To see a complete description of any property, right-click on its name or value and select **What’s This**; a help window opens that displays the reference page entry for it.

The Property Inspector displays most, but not all, properties of Handle Graphics objects. For example, the `parent` and `children` of HG objects are not shown.

`inspect h` displays a Property Inspector window that enables modification of the string 'h', not the object whose handle is h. If you modify properties at the MATLAB command line, you must refresh the Property Inspector window to see the change reflected there. Refresh the Property Inspector by reinvoking `inspect` on the object.

---

## Examples

### Example 1

Create a surface mesh plot and view its properties with the Property Inspector.

```
Z = peaks(30);
h = surf(Z);
inspect(h);
```

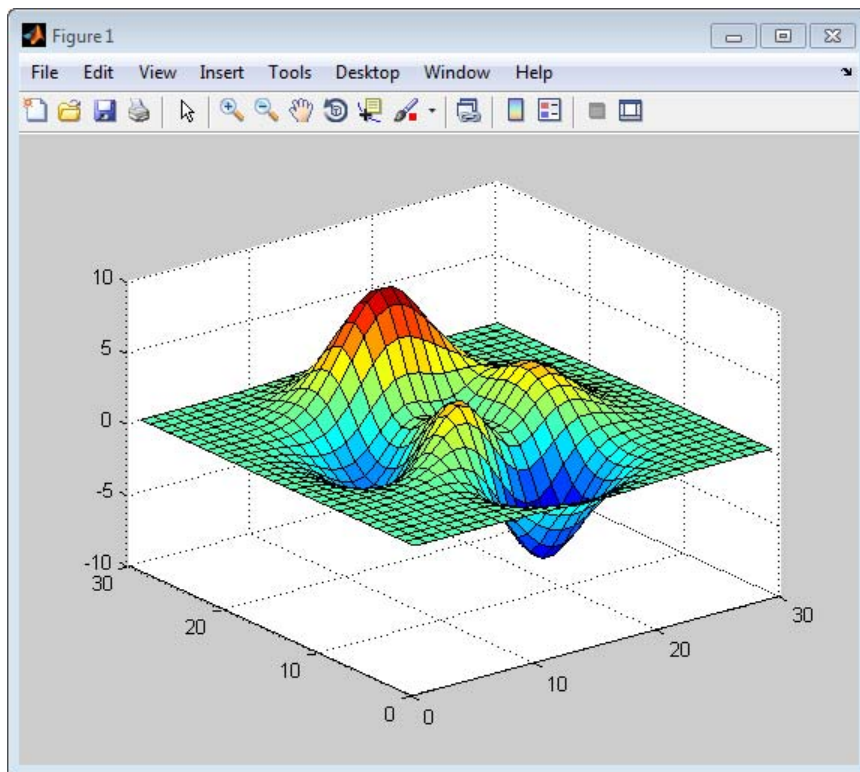

In the Property Inspector, change the FaceAlpha property from 1.0 to 0.4 (equivalent to the command `set(h, 'FaceAlpha', 0.4)`). FaceAlpha controls the transparency of patch faces.

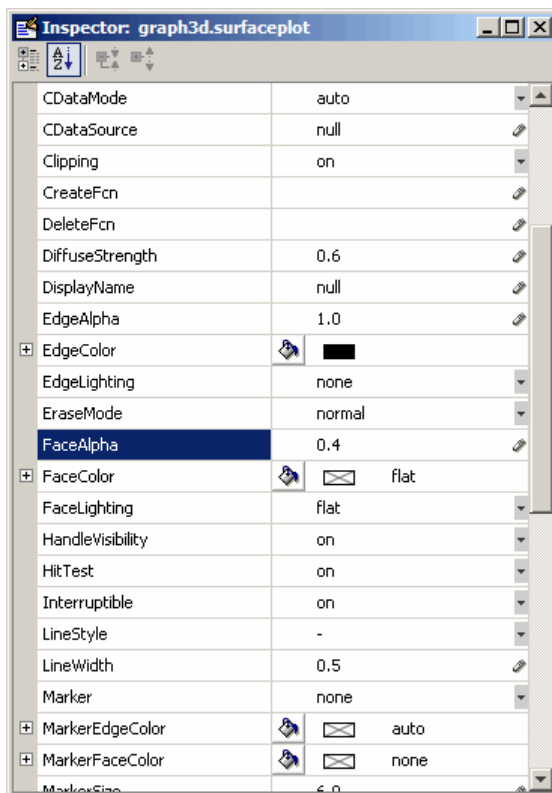

When you press **Enter** or click a different field, the FaceAlpha property of the surface object updates.

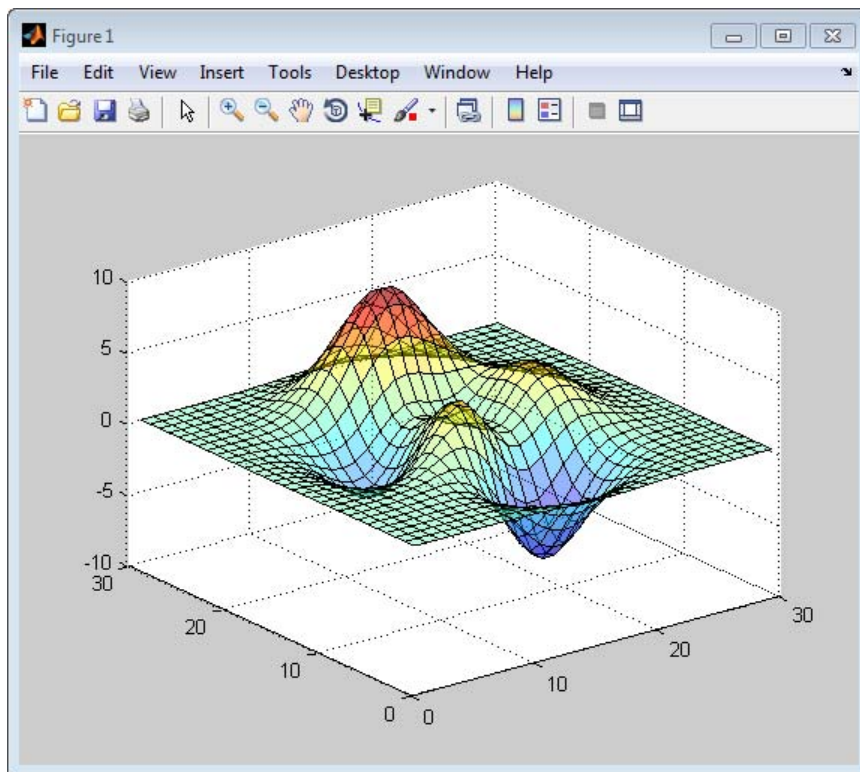

## Example 2

Create a serial port object for COM1 on a Windows platform and use the Property Inspector to peruse its properties:

```
s = serial('COM1');
inspect(s);
```

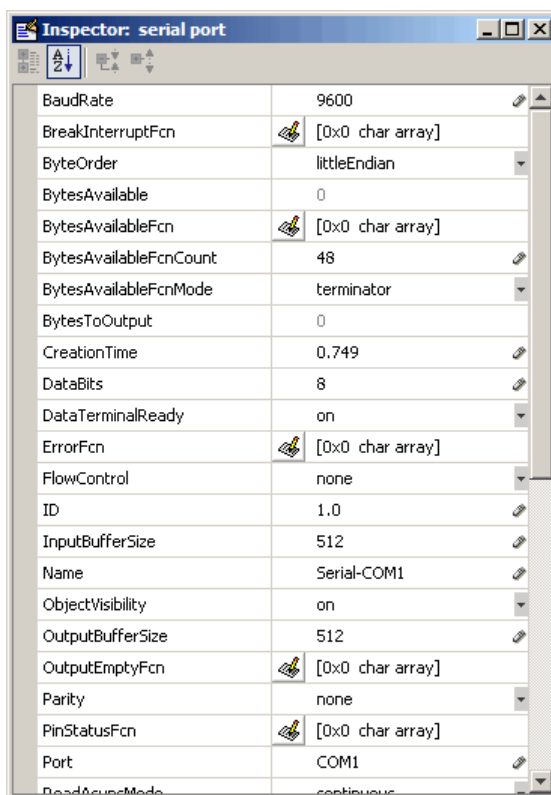

Because COM objects do not define property groupings, the Property Inspector enables only the alphabetical list view of COM object properties.

### Example 3

Create a COM Excel server and open a Property Inspector window with inspect.

```
h = actxserver('excel.application');
inspect(h);
```

Scroll down until you see the `CalculationInterruptKey` property, which by default is `xlAnyKey`. Click on the down-arrow in the right margin of the Property Inspector, and then select `xlEscKey` from the drop-down menu.

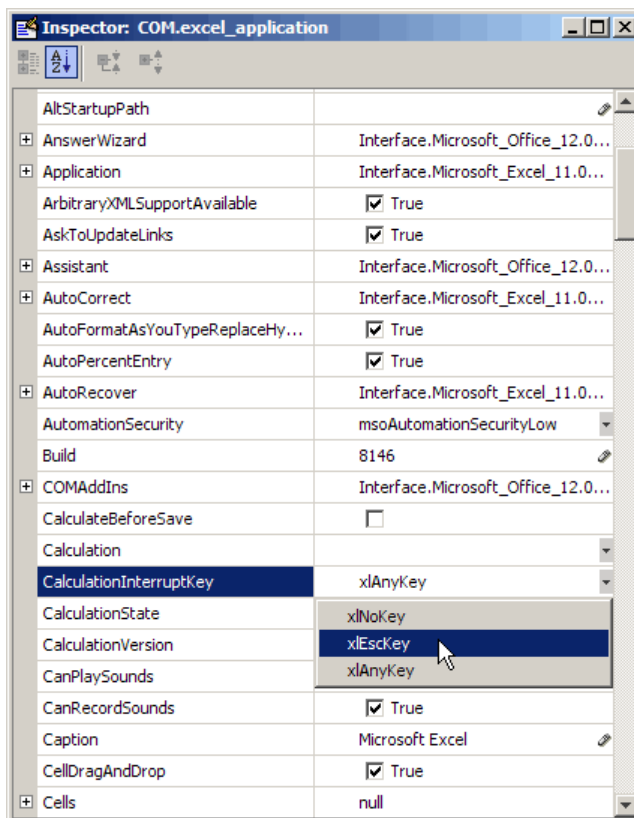

Check this property in the MATLAB Command Window using `get` to confirm that the property value changed.

```
get(h, 'CalculationInterruptKey')
```

```
ans =
```



x1EscKey

**See Also**

get | set | isprop | guide | addproperty | deleteproperty

# instrcallback

---

**Purpose** Event information when event occurs

**Syntax** `instrcallback(obj,event)`

**Description** `instrcallback(obj,event)` displays a message that contains the event type, event, the time the event occurred, and the name of the serial port object, `obj`, that caused the event to occur.

For error events, the error message is also displayed. For pin status events, the pin that changed value and its value are also displayed.

**Tips** Use `instrcallback` as a template to create callback functions that suit your specific application needs.

**Examples** The following example creates the serial port object, `s`, on a Windows platform. It configures `s` to execute `instrcallback` when an output-empty event occurs. The event occurs after the `*IDN?` command is written to the instrument.

```
s = serial('COM1');
set(s,'OutputEmptyFcn',@instrcallback)
fopen(s)
fprintf(s,'*IDN?','async')
```

```
OutputEmpty event occurred at 08:37:49 for the object:
Serial-COM1.
```

Read the identification information from the input buffer and end the serial port session.

```
idn = fscanf(s);
fclose(s)
delete(s)
clear s
```

|                    |                                                                                                                                                                                                                                                                                                                                                                                                                                                                                                                                                                                                                                                                                                                                                                                                                                                                          |
|--------------------|--------------------------------------------------------------------------------------------------------------------------------------------------------------------------------------------------------------------------------------------------------------------------------------------------------------------------------------------------------------------------------------------------------------------------------------------------------------------------------------------------------------------------------------------------------------------------------------------------------------------------------------------------------------------------------------------------------------------------------------------------------------------------------------------------------------------------------------------------------------------------|
| <b>Purpose</b>     | Read serial port objects from memory to MATLAB workspace                                                                                                                                                                                                                                                                                                                                                                                                                                                                                                                                                                                                                                                                                                                                                                                                                 |
| <b>Syntax</b>      | <pre>out = instrfind out = instrfind('PropertyName',PropertyValue,...) out = instrfind(S) out = instrfind(obj,'PropertyName',PropertyValue,...)</pre>                                                                                                                                                                                                                                                                                                                                                                                                                                                                                                                                                                                                                                                                                                                    |
| <b>Description</b> | <p><code>out = instrfind</code> returns all valid serial port objects as an array to <code>out</code>.</p> <p><code>out = instrfind('PropertyName',PropertyValue,...)</code> returns an array of serial port objects whose property names and property values match those specified.</p> <p><code>out = instrfind(S)</code> returns an array of serial port objects whose property names and property values match those defined in the structure <code>S</code>. The field names of <code>S</code> are the property names, while the field values are the associated property values.</p> <p><code>out = instrfind(obj,'PropertyName',PropertyValue,...)</code> restricts the search for matching property name/property value pairs to the serial port objects listed in <code>obj</code>.</p>                                                                         |
| <b>Tips</b>        | <p>Refer to “Displaying Property Names and Property Values” for a list of serial port object properties that you can use with <code>instrfind</code>.</p> <p>You must specify property values using the same format as the <code>get</code> function returns. For example, if <code>get</code> returns the <code>Name</code> property value as <code>MyObject</code>, <code>instrfind</code> will not find an object with a <code>Name</code> property value of <code>myobject</code>. However, this is not the case for properties that have a finite set of string values. For example, <code>instrfind</code> will find an object with a <code>Parity</code> property value of <code>Even</code> or <code>even</code>.</p> <p>You can use property name/property value string pairs, structures, and cell array pairs in the same call to <code>instrfind</code>.</p> |
| <b>Examples</b>    | <p>Suppose you create the following two serial port objects on a Windows platform.</p> <pre>s1 = serial('COM1');</pre>                                                                                                                                                                                                                                                                                                                                                                                                                                                                                                                                                                                                                                                                                                                                                   |

# instrfind

---

```
s2 = serial('COM2');
set(s2, 'BaudRate', 4800)
fopen([s1 s2])
```

You can use `instrfind` to return serial port objects based on property values.

```
out1 = instrfind('Port', 'COM1');
out2 = instrfind({'Port', 'BaudRate'}, {'COM2', 4800});
```

You can also use `instrfind` to return cleared serial port objects to the MATLAB workspace.

```
clear s1 s2
newobjs = instrfind
```

```
Instrument Object Array
Index: Type: Status: Name:
1 serial open Serial-COM1
2 serial open Serial-COM2
```

To close both `s1` and `s2`

```
fclose(newobjs)
```

## See Also

```
clear | get
```

**Purpose** Find visible and hidden serial port objects

**Syntax**

```
out = instrfindall
out = instrfindall('P1',V1,...)
out = instrfindall(s)
out = instrfindall(objs,'P1',V1,...)
```

**Description** `out = instrfindall` finds all serial port objects, regardless of the value of the object's `ObjectVisibility` property. The object or objects are returned to `out`.

`out = instrfindall('P1',V1,...)` returns an array, `out`, of serial port objects whose property names and corresponding property values match those specified as arguments.

`out = instrfindall(s)` returns an array, `out`, of serial port objects whose property names and corresponding property values match those specified in the structure `s`, where the field names correspond to property names and the field values correspond to the current value of the respective property.

`out = instrfindall(objs,'P1',V1,...)` restricts the search for objects with matching property name/value pairs to the serial port objects listed in `objs`.

Note that you can use string property name/property value pairs, structures, and cell array property name/property value pairs in the same call to `instrfindall`.

**Tips** `instrfindall` differs from `instrfind` in that it finds objects whose `ObjectVisibility` property is set to `off`.

Property values are case sensitive. You must specify property values using the same format as that returned by the `get` function. For example, if `get` returns the `Name` property value as `'MyObject'`, `instrfindall` will not find an object with a `Name` property value of `'myobject'`. However, this is not the case for properties that have a finite set of string values. For example, `instrfindall` will find an object with a `Parity` property value of `'Even'` or `'even'`.

# instrfindall

---

## Examples

Suppose you create the following serial port objects on a Windows platform:

```
s1 = serial('COM1');
s2 = serial('COM2');
set(s2,'ObjectVisibility','off')
```

Because object `s2` has its `ObjectVisibility` set to `'off'`, it is not visible to commands like `instrfind`:

```
instrfind
```

```
Serial Port Object : Serial-COM1
```

However, `instrfindall` finds all objects regardless of the value of `ObjectVisibility`:

```
instrfindall
```

```
Instrument Object Array
Index: Type: Status: Name:
1 serial closed Serial-COM1
2 serial closed Serial-COM2
```

The following statements use `instrfindall` to return objects with specific property settings, which are passed as cell arrays:

```
props = {'PrimaryAddress','SecondaryAddress'};
vals = {2,0};
obj = instrfindall(props,vals);
```

You can use `instrfindall` as an argument when you want to apply the command to all objects, visible and invisible. For example, the following statement makes all objects visible:

```
set(instrfindall,'ObjectVisibility','on')
```

## See Also

`get` | `instrfind` | `ObjectVisibility`

**Purpose** Convert integer to string

**Syntax** `str = int2str(N)`

**Description** `str = int2str(N)` converts an integer to a string with integer format. The input `N` can be a single integer or a vector or matrix of integers. Noninteger inputs are rounded before conversion.

**Examples** `int2str(2+3)` is the string '5'.

One way to label a plot is

```
title(['case number ' int2str(n)])
```

For matrix or vector inputs, `int2str` returns a string matrix:

```
int2str(eye(3))
```

```
ans =
```

```
1 0 0
0 1 0
0 0 1
```

**See Also** `fprintf` | `num2str` | `sprintf` | `cast`

# int8

---

|                         |                                                                                                                                                                                                                                                                                                                                                                                                          |
|-------------------------|----------------------------------------------------------------------------------------------------------------------------------------------------------------------------------------------------------------------------------------------------------------------------------------------------------------------------------------------------------------------------------------------------------|
| <b>Purpose</b>          | Convert to 8-bit signed integer                                                                                                                                                                                                                                                                                                                                                                          |
| <b>Syntax</b>           | <code>intArray = int8(array)</code>                                                                                                                                                                                                                                                                                                                                                                      |
| <b>Description</b>      | <code>intArray = int8(array)</code> converts the elements of an array into signed 8-bit (1-byte) integers of class <code>int8</code> .                                                                                                                                                                                                                                                                   |
| <b>Input Arguments</b>  | <b>array</b><br>Array of any numeric class, such as <code>single</code> or <code>double</code> . If array is already of class <code>int8</code> , the <code>int8</code> function has no effect.                                                                                                                                                                                                          |
| <b>Output Arguments</b> | <b>intArray</b><br>Array of class <code>int8</code> . Values range from $-2^7$ to $2^7 - 1$ .<br>The <code>int8</code> function maps any values in array that are outside the limit to the nearest endpoint. For example,<br><pre>int8(2^7)    % 2^7 = 128</pre><br>returns<br><pre>ans =<br/>    127</pre>                                                                                              |
| <b>Examples</b>         | Convert a double array to <code>int8</code> :<br><pre>mydata = int8(magic(10));</pre>                                                                                                                                                                                                                                                                                                                    |
| <b>Alternatives</b>     | When preallocating integer arrays, specify the class in the call to functions that support a class name input (such as <code>zeros</code> , <code>ones</code> or <code>eye</code> ), rather than calling an integer conversion function. For example,<br><pre>I = int8(zeros(100));    % Creates an intermediate array</pre><br>is not as efficient as<br><pre>I = zeros(100, 'int8'); % Preferred</pre> |



**See Also**

`double` | `single` | `int16` | `int32` | `int64` | `uint8` | `uint16` | `uint32` | `uint64` | `intmax` | `intmin`

**Tutorials**

- “Integers”
- “Arithmetic Operations on Integer Classes”

# int16

---

|                         |                                                                                                                                                                                                                                                                                                                                                                                                             |
|-------------------------|-------------------------------------------------------------------------------------------------------------------------------------------------------------------------------------------------------------------------------------------------------------------------------------------------------------------------------------------------------------------------------------------------------------|
| <b>Purpose</b>          | Convert to 16-bit signed integer                                                                                                                                                                                                                                                                                                                                                                            |
| <b>Syntax</b>           | <code>intArray = int16(array)</code>                                                                                                                                                                                                                                                                                                                                                                        |
| <b>Description</b>      | <code>intArray = int16(array)</code> converts the elements of an array into signed 16-bit (2-byte) integers of class <code>int16</code> .                                                                                                                                                                                                                                                                   |
| <b>Input Arguments</b>  | <b>array</b><br>Array of any numeric class, such as <code>single</code> or <code>double</code> . If array is already of class <code>int16</code> , the <code>int16</code> function has no effect.                                                                                                                                                                                                           |
| <b>Output Arguments</b> | <b>intArray</b><br>Array of class <code>int16</code> . Values range from $-2^{15}$ to $2^{15} - 1$ .<br>The <code>int16</code> function maps any values in array that are outside the limit to the nearest endpoint. For example,<br><code>int16(2^15) % 2^15 = 32768</code><br>returns<br><code>ans =</code><br>32767                                                                                      |
| <b>Examples</b>         | Convert a double array to <code>int16</code> :<br><code>mydata = int16(magic(100));</code>                                                                                                                                                                                                                                                                                                                  |
| <b>Alternatives</b>     | When preallocating integer arrays, specify the class in the call to functions that support a class name input (such as <code>zeros</code> , <code>ones</code> or <code>eye</code> ), rather than calling an integer conversion function. For example,<br><code>I = int16(zeros(100)); % Creates an intermediate array</code><br>is not as efficient as<br><code>I = zeros(100, 'int16'); % Preferred</code> |

**See Also**

`double` | `single` | `int8` | `int32` | `int64` | `uint8` | `uint16` | `uint32` | `uint64` | `intmax` | `intmin`

**Tutorials**

- “Integers”
- “Arithmetic Operations on Integer Classes”

# int32

---

**Purpose** Convert to 32-bit signed integer

**Syntax** `intArray = int32(array)`

**Description** `intArray = int32(array)` converts the elements of an array into signed 32-bit (4-byte) integers of class `int32`.

**Input Arguments** **array**  
Array of any numeric class, such as `single` or `double`. If array is already of class `int32`, the `int32` function has no effect.

**Output Arguments** **intArray**  
Array of class `int32`. Values range from  $-2^{31}$  to  $2^{31} - 1$ .  
The `int32` function maps any values in array that are outside the limit to the nearest endpoint. For example,

```
int32(2^31) % 2^31 = 2147483648
```

returns

```
ans =
 2147483647
```

**Examples** Convert a double array to `int32`:

```
mydata = int32(magic(100));
```

**Alternatives** When preallocating integer arrays, specify the class in the call to functions that support a class name input (such as `zeros`, `ones` or `eye`), rather than calling an integer conversion function. For example,

```
I = int32(zeros(100)); % Creates an intermediate array
```

is not as efficient as

```
I = zeros(100, 'int32'); % Preferred
```

**See Also**

`double` | `single` | `int8` | `int16` | `int64` | `uint8` | `uint16` | `uint32` | `uint64` | `intmax` | `intmin`

**Tutorials**

- “Integers”
- “Arithmetic Operations on Integer Classes”

# int64

---

**Purpose** Convert to 64-bit signed integer

**Syntax** `intArray = int64(array)`

**Description** `intArray = int64(array)` converts the elements of an array into signed 64-bit (8-byte) integers of class `int64`.

**Tips** Double-precision floating-point numbers have only 52 bits in the mantissa. Therefore, `double` values cannot represent all integers greater than  $2^{53}$  correctly. Before performing arithmetic operations on values larger than  $2^{53}$  in magnitude, convert the values to 64-bit integers. For example,

```
x = int64(2^53+1); % Floating-point arithmetic, loses precision
```

is not as accurate as the 64-bit integer arithmetic operation:

```
x = int64(2^53) + 1; % Preferred
```

## Input Arguments

### **array**

Array of any numeric class, such as `single` or `double`. If `array` is already of class `int64`, the `int64` function has no effect.

## Output Arguments

### **intArray**

Array of class `int64`. Values range from  $-2^{63}$  to  $2^{63} - 1$ .

The `int64` function maps any values in `array` that are outside the limit to the nearest endpoint. For example,

```
int64(2^63) % 2^63 = 9223372036854775808
```

returns

```
ans =
 9223372036854775807
```

**Examples**

Convert a literal value to int64:

```
x = int64(9007199254740993);
```

**Alternatives**

When preallocating integer arrays, specify the class in the call to functions that support a class name input (such as `zeros`, `ones` or `eye`), rather than calling an integer conversion function. For example,

```
I = int64(zeros(100)); % Creates an intermediate array
```

is not as efficient as

```
I = zeros(100, 'int64'); % Preferred
```

**See Also**

`double` | `single` | `int8` | `int16` | `int32` | `uint8` | `uint16` | `uint32` | `uint64` | `intmax` | `intmin`

**Tutorials**

- “Integers”
- “Arithmetic Operations on Integer Classes”

# integral

---

**Purpose** Numerically evaluate integral

**Syntax**  
`q = integral(fun,xmin,xmax)`  
`q = integral(fun,xmin,xmax,Name,Value)`

**Description** `q = integral(fun,xmin,xmax)` approximates the integral of function `fun` from `xmin` to `xmax` using global adaptive quadrature and default error tolerances.

`q = integral(fun,xmin,xmax,Name,Value)` specifies additional options with one or more `Name, Value` pair arguments.

## Input Arguments

**fun - Integrand**  
function handle

Integrand, specified as a function handle, defines the function to be integrated from `xmin` to `xmax`. For scalar-valued problems, the function `y = fun(x)` must accept a vector argument, `x`, and return a vector result, `y`. This generally means that `fun` must use array operators instead of matrix operators. For example, use `.*` (times) rather than `*` (mtimes). If you set the 'ArrayValued' option to true, `fun` must accept a scalar and return an array of fixed size.

**xmin - Lower limit of x**  
real number | complex number

Lower limit of `x`, specified as a real (finite or infinite) scalar value or a complex (finite) scalar value. If either `xmin` or `xmax` are complex, `integral` approximates the path integral from `xmin` to `xmax` over a straight line path.

**Data Types**  
double | single  
**Complex Number Support:** Yes

**xmax - Upper limit of x**  
real number | complex number



---

Upper limit of  $x$ , specified as a real (finite or infinite) scalar value or a complex (finite) scalar value. If either `xmin` or `xmax` are complex, `integral` approximates the path integral from `xmin` to `xmax` over a straight line path.

**Data Types**

double | single

**Complex Number Support:** Yes**Name-Value Pair Arguments**

Specify optional comma-separated pairs of `Name,Value` arguments. `Name` is the argument name and `Value` is the corresponding value. `Name` must appear inside single quotes ( ' '). You can specify several name and value pair arguments in any order as `Name1,Value1,...,NameN,ValueN`.

**Example:** `'AbsTol',1e-12` sets the absolute error tolerance to approximately 12 decimal places of accuracy.

**'AbsTol' - Absolute error tolerance**

nonnegative real number

Absolute error tolerance, specified as the comma-separated pair consisting of `'AbsTol'` and a nonnegative real number. `integral` uses the absolute error tolerance to limit an estimate of the absolute error,  $|q - Q|$ , where  $q$  is the computed value of the integral and  $Q$  is the (unknown) exact value. `integral` might provide more decimal places of precision if you decrease the absolute error tolerance. The default value is `1e-10`.

---

**Note** `AbsTol` and `RelTol` work together. `integral` might satisfy the absolute error tolerance or the relative error tolerance, but not necessarily both. For more information on using these tolerances, see the “Tips” on page 1-3345 section.

---

**Example:** 'AbsTol', 1e-12 sets the absolute error tolerance to approximately 12 decimal places of accuracy.

## Data Types

single | double

## 'RelTol' - Relative error tolerance

nonnegative real number

Relative error tolerance, specified as the comma-separated pair consisting of 'RelTol' and a nonnegative real number. `integral` uses the relative error tolerance to limit an estimate of the relative error,  $|q - Q|/|Q|$ , where  $q$  is the computed value of the integral and  $Q$  is the (unknown) exact value. `integral` might provide more significant digits of precision if you decrease the relative error tolerance. The default value is 1e-6.

---

**Note** `RelTol` and `AbsTol` work together. `integral` might satisfy the relative error tolerance or the absolute error tolerance, but not necessarily both. For more information on using these tolerances, see the Tips section.

---

**Example:** 'RelTol', 1e-9 sets the relative error tolerance to approximately 9 significant digits.

## Data Types

single | double

## 'ArrayValued' - Array-valued function flag

false (default) | true | 0 | 1

Array-valued function flag, specified as the comma-separated pair consisting of 'ArrayValued' and either `false`, `true`, `0`, or `1`. Set this flag to `true` when you want to integrate over an array-valued function. The shape of `fun(x)` can be a vector, matrix, or N-D array.

**Example:** 'ArrayValued', true indicates that the integrand is an array-valued function.

### 'Waypoints' - Integration waypoints

vector

Integration waypoints, specified as the comma-separated pair consisting of 'Waypoints' and a vector of real or complex numbers. Use waypoints to indicate any points in the integration interval you would like the integrator to use. You can use waypoints to integrate efficiently across discontinuities of the integrand. Specify the locations of the discontinuities in the vector you supply.

You can specify waypoints when you want to perform complex contour integration. If `xmin`, `xmax`, or any entry of the waypoints vector is complex, the integration is performed over a sequence of straight line paths in the complex plane.

**Example:** 'Waypoints', [1+1i, 1-1i] specifies two complex waypoints along the interval of integration.

### Data Types

single | double

**Complex Number Support:** Yes

## Output Arguments

### q - Computed integral

numeric value | numeric array

Computed integral of  $\text{fun}(x)$  between the limits `xmin` and `xmax`, returned as a numeric value or numeric array.

## Tips

- Do not use waypoints to specify singularities. Instead, split the interval and add the results of separate integrations with the singularities at the endpoints.
- The integral function attempts to satisfy:

$$\text{abs}(q - Q) \leq \max(\text{AbsTol}, \text{RelTol} * \text{abs}(q))$$

where  $q$  is the computed value of the integral and  $Q$  is the (unknown) exact value. The absolute and relative tolerances provide a way of trading off accuracy and computation time. Usually, the relative tolerance determines the accuracy of the integration. However if  $\text{abs}(q)$  is sufficiently small, the absolute tolerance determines the accuracy of the integration. You should generally specify both absolute and relative tolerances together.

- If you specify a complex value for  $x_{\min}$ ,  $x_{\max}$ , or any waypoint, all of your limits and waypoints must be finite.
- If you are specifying single-precision limits of integration, or if `fun` returns single-precision results, you might need to specify larger absolute and relative error tolerances.

## Examples

### Evaluate Improper Integral

Create the anonymous function  $f(x) = e^{-x^2}(\ln x)^2$ .

```
fun = @(x) exp(-x.^2).*log(x).^2;
```

Evaluate the integral from  $x=0$  to  $x=\text{Inf}$ .

```
q = integral(fun,0,Inf)
```

```
q =
```

```
1.9475
```

### Integrate Parameterized Function

Create the anonymous function  $f(x) = 1/(x^3 - 2x - c)$  with one parameter,  $c$ .

```
fun = @(x,c) 1./(x.^3-2*x-c);
```

Evaluate the integral from  $x=0$  to  $x=2$  at  $c=5$ .

```
q = integral(@(x)fun(x,5),0,2)
```

```
q =
-0.4605
```

### Evaluate Integral with Singularity at the Lower Limit of Integration

Create the anonymous function  $f(x) = \ln(x)$ .

```
fun = @(x)log(x);
```

Evaluate the integral from  $x=0$  to  $x=1$  with the default error tolerances.

```
format long
q1 = integral(fun,0,1)
```

```
q1 =
-1.000000010959678
```

Evaluate the integral again, specifying approximately 12 decimal places of accuracy.

```
q2 = integral(fun,0,1,'RelTol',0,'AbsTol',1e-12)
```

```
q2 =
-1.000000000000010
```

### Complex Contour Integration Using Waypoints

Specify waypoints  $[1+1i, 1-1i]$  to integrate over the triangular path: 0 to  $1+1i$  to  $1-1i$  to 0.

Create the anonymous function  $f(z) = 1/(2z - 1)$ .

```
fun = @(z) 1./(2*z-1);
```

# integral

---

Integrate in the complex plane over the triangular path from 0 to  $1+i$  to  $1-i$  to 0.

```
q = integral(fun,0,0,'Waypoints',[1+1i,1-1i])
```

```
q =
```

```
0 - 3.1416i
```

## Integrate Vector-Valued Function

Specify 'ArrayValued', true to evaluate the integral of an array-valued or vector-valued function.

Create the anonymous vector-valued function  $f(x) = [\sin x, \sin 2x, \sin 3x, \sin 4x, \sin 5x]$  and integrate from  $x=0$  to  $x=1$ .

```
fun = @(x)sin((1:5)*x);
q = integral(fun,0,1,'ArrayValued',true)
```

```
q =
```

```
0.4597 0.7081 0.6633 0.4134 0.1433
```

## Improper Integral of an Oscillatory Function

Create the anonymous function  $f(x) = x^5 e^{-x} \sin x$ .

```
fun = @(x)x.^5.*exp(-x).*sin(x);
```

Evaluate the integral from  $x=0$  to  $x=Inf$ , adjusting the absolute and relative tolerances.

```
format long
q = integral(fun,0,Inf,'RelTol',1e-8,'AbsTol',1e-13)
```

```
q =
```

```
-14.999999999998364
```

**See Also**

[integral2](#) | [integral3](#) | [function\\_handle](#) | [trapz](#)

**Concepts**

- “Parameterizing Functions”

# integral2

---

**Purpose** Numerically evaluate double integral

**Syntax**  
`q = integral2(fun,xmin,xmax,ymin,ymax)`  
`q = integral2(fun,xmin,xmax,ymin,ymax,Name,Value)`

**Description** `q = integral2(fun,xmin,xmax,ymin,ymax)` approximates the integral of the function  $z = \text{fun}(x,y)$  over the planar region  $x_{\min} \leq x \leq x_{\max}$  and  $y_{\min}(x) \leq y \leq y_{\max}(x)$ .

`q = integral2(fun,xmin,xmax,ymin,ymax,Name,Value)` specifies additional options with one or more Name,Value pair arguments.

## Input Arguments

**fun - Integrand**  
function handle

Integrand, specified as a function handle, defines the function to be integrated over the planar region  $x_{\min} \leq x \leq x_{\max}$  and  $y_{\min}(x) \leq y \leq y_{\max}(x)$ . The function `fun` must accept two arrays of the same size and return an array of corresponding values. It must perform element-wise operations.

**Data Types**  
function\_handle

**xmin - Lower limit of x**  
real number

Lower limit of  $x$ , specified as a real scalar value that is either finite or infinite.

**Data Types**  
double | single

**xmax - Upper limit of x**  
real number

Upper limit of  $x$ , specified as a real scalar value that is either finite or infinite.



**Data Types**

double | single

**ymin - Lower limit of y**

real number | function handle

Lower limit of  $y$ , specified as a real scalar value that is either finite or infinite. You can specify `ymin` to be a function handle (a function of  $x$ ) when integrating over a nonrectangular region.

**Data Types**

double | function\_handle | single

**ymax - Upper limit of y**

real number | function handle

Upper limit of  $y$ , specified as a real scalar value that is either finite or infinite. You also can specify `ymax` to be a function handle (a function of  $x$ ) when integrating over a nonrectangular region.

**Data Types**

double | function\_handle | single

**Name-Value Pair Arguments**

Specify optional comma-separated pairs of `Name, Value` arguments. `Name` is the argument name and `Value` is the corresponding value. `Name` must appear inside single quotes ( ' '). You can specify several name and value pair arguments in any order as `Name1, Value1, ..., NameN, ValueN`.

**Example:** `'AbsTol', 1e-12` sets the absolute error tolerance to approximately 12 decimal places of accuracy.

**'AbsTol' - Absolute error tolerance**

nonnegative real number

Absolute error tolerance, specified as the comma-separated pair consisting of `'AbsTol'` and a nonnegative real number. `integral2` uses the absolute error tolerance to limit an estimate of the absolute error,  $|q - Q|$ , where  $q$  is the computed value of the integral and  $Q$  is

the (unknown) exact value. `integral2` might provide more decimal places of precision if you decrease the absolute error tolerance. The default value is  $1e-10$ .

---

**Note** `AbsTol` and `RelTol` work together. `integral2` might satisfy the absolute error tolerance or the relative error tolerance, but not necessarily both. For more information on using these tolerances, see the “Tips” on page 1-3354 section.

---

**Example:** `'AbsTol', 1e-12` sets the absolute error tolerance to approximately 12 decimal places of accuracy.

## Data Types

`double` | `single`

## 'RelTol' - Relative error tolerance

nonnegative real number

Relative error tolerance, specified as the comma-separated pair consisting of `'RelTol'` and a nonnegative real number. `integral2` uses the relative error tolerance to limit an estimate of the relative error,  $|q - Q|/|Q|$ , where  $q$  is the computed value of the integral and  $Q$  is the (unknown) exact value. `integral2` might provide more significant digits of precision if you decrease the relative error tolerance. The default value is  $1e-6$ .

---

**Note** `RelTol` and `AbsTol` work together. `integral2` might satisfy the relative error tolerance or the absolute error tolerance, but not necessarily both. For more information on using these tolerances, see the “Tips” on page 1-3354 section.

---

**Example:** `'RelTol', 1e-9` sets the relative error tolerance to approximately 9 significant digits.

## Data Types

double | single

## 'Method' - Integration method

'auto' (default) | 'tiled' | 'iterated'

Integration method, specified as the comma-separated pair consisting of 'Method' and one of the methods described below.

| Integration Method | Description                                                                                                                                                                                                                                                                     |
|--------------------|---------------------------------------------------------------------------------------------------------------------------------------------------------------------------------------------------------------------------------------------------------------------------------|
| 'auto'             | For most cases, <code>integral2</code> uses the 'tiled' method. It uses the 'iterated' method when any of the integration limits are infinite. This is the default method.                                                                                                      |
| 'tiled'            | <code>integral2</code> transforms the region of integration to a rectangular shape and subdivides it into smaller rectangular regions as needed. The integration limits must be finite.                                                                                         |
| 'iterated'         | <code>integral2</code> calls <code>integral</code> to perform an iterated integral. The outer integral is evaluated over $x_{\min} \leq x \leq x_{\max}$ . The inner integral is evaluated over $y_{\min}(x) \leq y \leq y_{\max}(x)$ . The integration limits can be infinite. |

**Example:** 'Method', 'tiled' specifies the tiled integration method.

## Output Arguments

### q - Computed integral

numeric value

Computed integral of `fun(x,y)` over the specified region, returned as a numeric value.

# integral2

---

## Tips

- The `integral2` function attempts to satisfy:

$$\text{abs}(q - Q) \leq \max(\text{AbsTol}, \text{RelTol} * \text{abs}(q))$$

where  $q$  is the computed value of the integral and  $Q$  is the (unknown) exact value. The absolute and relative tolerances provide a way of trading off accuracy and computation time. Usually, the relative tolerance determines the accuracy of the integration. However if  $\text{abs}(q)$  is sufficiently small, the absolute tolerance determines the accuracy of the integration. You should generally specify both absolute and relative tolerances together.

- The `'iterated'` method can be more effective when your function has discontinuities within the integration region. However, the best performance and accuracy occurs when you split the integral at the points of discontinuity and sum the results of multiple integrations.
- When integrating over nonrectangular regions, the best performance and accuracy occurs when `ymin`, `ymax`, (or both) are function handles. Avoid setting integrand function values to zero to integrate over a nonrectangular region. If you must do this, specify `'iterated'` method.
- Use the `'iterated'` method when `ymin`, `ymax`, (or both) are unbounded functions.
- When parameterizing anonymous functions, be aware that parameter values persist for the life of the function handle. For example, the function `fun = @(x,y) x + y + a` uses the value of `a` at the time `fun` was created. If you later decide to change the value of `a`, you must redefine the anonymous function with the new value.
- If you are specifying single-precision limits of integration, or if `fun` returns single-precision results, you might need to specify larger absolute and relative error tolerances.

## Examples

### Integrate Triangular Region with Singularity at the Boundary

The function

$$f(x,y) = \frac{1}{(\sqrt{x+y})(1+x+y)}$$

is undefined when  $x$  and  $y$  are zero. `integral2` performs best when singularities are on the integration boundary.

Create the anonymous function.

```
fun = @(x,y) 1./ (sqrt(x + y) .* (1 + x + y).^2)
```

Integrate over the triangular region bounded by  $0 \leq x \leq 1$  and  $0 \leq y \leq 1 - x$ .

```
ymax = @(x) 1 - x
q = integral2(fun,0,1,0,ymax)
```

```
q =
```

```
0.2854
```

## Evaluate Double Integral in Polar Coordinates

Define the function

$$f(\theta,r) = \frac{r}{\sqrt{r \cos \theta + r \sin \theta} (1 + r \cos \theta + r \sin \theta)^2}$$

```
fun = @(x,y) 1./ (sqrt(x + y) .* (1 + x + y).^2);
polarfun = @(theta,r) fun(r.*cos(theta),r.*sin(theta)).*r;
```

Define a function for the upper limit of  $r$ .

```
rmax = @(theta) 1./(sin(theta) + cos(theta));
```

Integrate over the region bounded by  $0 \leq \theta \leq \pi/2$  and  $0 \leq r \leq rmax$ .

```
q = integral2(polarfun,0,pi/2,0,rmax)
```

```
q =
```

0.2854

## Evaluate Double Integral of Parameterized Function with Specific Method and Error Tolerance

Create the anonymous parameterized function  $f(x,y) = ax^2 + by^2$  with parameters  $a=3$  and  $b=5$ .

```
a = 3; b = 5;
fun = @(x,y) a*x.^2 + b*y.^2;
```

Evaluate the integral over the region  $0 \leq x \leq 5$  and  $-5 \leq y \leq 0$ . Specify the 'iterated' method and approximately 10 significant digits of accuracy.

```
format long
q = integral2(fun,0,5,-5,0,'Method','iterated',...
'AbsTol',0,'RelTol',1e-10)
```

q =

1.666666666666666e+03

### See Also

[integral](#) | [integral3](#) | [function\\_handle](#) | [trapz](#)

### Concepts

- “Parameterizing Functions”

## Purpose

Numerically evaluate triple integral

## Syntax

```
q = integral3(fun,xmin,xmax,ymin,ymax,zmin,zmax)
q = integral3(fun,xmin,xmax,ymin,ymax,zmin,zmax,Name,Value)
```

## Description

`q = integral3(fun,xmin,xmax,ymin,ymax,zmin,zmax)` approximates the integral of the function  $z = \text{fun}(x,y,z)$  over the region  $x_{\min} \leq x \leq x_{\max}$ ,  $y_{\min}(x) \leq y \leq y_{\max}(x)$  and  $z_{\min}(x,y) \leq z \leq z_{\max}(x,y)$ .

`q = integral3(fun,xmin,xmax,ymin,ymax,zmin,zmax,Name,Value)` specifies additional options with one or more `Name,Value` pair arguments.

## Input Arguments

### **fun** - Integrand

function handle

Integrand, specified as a function handle, defines the function to be integrated over the region  $x_{\min} \leq x \leq x_{\max}$ ,  $y_{\min}(x) \leq y \leq y_{\max}(x)$ , and  $z_{\min}(x,y) \leq z \leq z_{\max}(x,y)$ . The function `fun` must accept three arrays of the same size and return an array of corresponding values. It must perform element-wise operations.

### **Data Types**

function\_handle

### **xmin** - Lower limit of *x*

real number

Lower limit of  $x$ , specified as a real scalar value that is either finite or infinite.

### **Example:**

### **Data Types**

double | single

### **xmax** - Upper limit of *x*

real number

Upper limit of  $x$ , specified as a real scalar value that is either finite or infinite.

### Data Types

double | single

### **ymin** - Lower limit of $y$

real number | function handle

Lower limit of  $y$ , specified as a real scalar value that is either finite or infinite. You also can specify `ymin` to be a function handle (a function of  $x$ ) when integrating over a nonrectangular region.

### Example:

### Data Types

double | function\_handle | single

### **ymax** - Upper limit of $y$

real number | function handle

Upper limit of  $y$ , specified as a real scalar value that is either finite or infinite. You also can specify `ymax` to be a function handle (a function of  $x$ ) when integrating over a nonrectangular region.

### Example:

### Data Types

double | function\_handle | single

### **zmin** - Lower limit of $z$

real number | function handle

Lower limit of  $z$ , specified as a real scalar value that is either finite or infinite. You also can specify `zmin` to be a function handle (a function of  $x,y$ ) when integrating over a nonrectangular region.

### Data Types

double | function\_handle | single

### **zmax** - Upper limit of $z$



real number | function handle

Upper limit of  $z$ , specified as a real scalar value that is either finite or infinite. You also can specify `zmax` to be a function handle (a function of  $x,y$ ) when integrating over a nonrectangular region.

### Data Types

double | function\_handle | single

### Name-Value Pair Arguments

Specify optional comma-separated pairs of `Name,Value` arguments. `Name` is the argument name and `Value` is the corresponding value. `Name` must appear inside single quotes ( ' '). You can specify several name and value pair arguments in any order as `Name1,Value1,...,NameN,ValueN`.

**Example:** `'AbsTol',1e-12` sets the absolute error tolerance to approximately 12 decimal places of accuracy.

### 'AbsTol' - Absolute error tolerance

nonnegative real number

Absolute error tolerance, specified as the comma-separated pair consisting of `'AbsTol'` and a nonnegative real number. `integral3` uses the absolute error tolerance to limit an estimate of the absolute error,  $|q - Q|$ , where  $q$  is the computed value of the integral and  $Q$  is the (unknown) exact value. `integral3` might provide more decimal places of precision if you decrease the absolute error tolerance. The default value is `1e-10`.

---

**Note** `AbsTol` and `RelTol` work together. `integral3` might satisfy the absolute error tolerance or the relative error tolerance, but not necessarily both. For more information on using these tolerances, see the “Tips” on page 1-3361 section.

---

**Example:** `'AbsTol',1e-12` sets the absolute error tolerance to approximately 12 decimal places of accuracy.

# integral3

---

## Data Types

double | single

## 'RelTol' - Relative error tolerance

nonnegative real number

Relative error tolerance, specified as the comma-separated pair consisting of 'RelTol' and a nonnegative real number. `integral3` uses the relative error tolerance to limit an estimate of the relative error,  $|q - Q|/|Q|$ , where  $q$  is the computed value of the integral and  $Q$  is the (unknown) exact value. `integral3` might provide more significant digits of precision if you decrease the relative error tolerance. The default value is  $1e-6$ .

---

**Note** `RelTol` and `AbsTol` work together. `integral3` might satisfy the relative error tolerance or the absolute error tolerance, but not necessarily both. For more information on using these tolerances, see the “Tips” on page 1-3361 section.

---

**Example:** `'RelTol', 1e-9` sets the relative error tolerance to approximately 9 significant digits.

## Data Types

double | single

## 'Method' - Integration method

'auto' (default) | 'tiled' | 'iterated'

Integration method, specified as the comma-separated pair consisting of 'Method' and one of the methods described below.

| Integration Method | Description                                                                                                                                                                                                                                                                                                                          |
|--------------------|--------------------------------------------------------------------------------------------------------------------------------------------------------------------------------------------------------------------------------------------------------------------------------------------------------------------------------------|
| 'auto'             | For most cases, <code>integral3</code> uses the 'tiled' method. It uses the 'iterated' method when any of the integration limits are infinite. This is the default method.                                                                                                                                                           |
| 'tiled'            | <code>integral3</code> calls <code>integral</code> to integrate over $x_{\min} \leq x \leq x_{\max}$ . It calls <code>integral2</code> with the 'tiled' method to evaluate the double integral over $y_{\min}(x) \leq y \leq y_{\max}(x)$ and $z_{\min}(x,y) \leq z \leq z_{\max}(x,y)$ .                                            |
| 'iterated'         | <code>integral3</code> calls <code>integral</code> to integrate over $x_{\min} \leq x \leq x_{\max}$ . It calls <code>integral2</code> with the 'iterated' method to evaluate the double integral over $y_{\min}(x) \leq y \leq y_{\max}(x)$ and $z_{\min}(x,y) \leq z \leq z_{\max}(x,y)$ . The integration limits can be infinite. |

**Example:** 'Method', 'tiled' specifies the tiled integration method.

## Output Arguments

### q - Computed integral

numeric value

Computed integral of `fun(x,y,z)` over the specified region, returned as a numeric value.

## Tips

- The `integral3` function attempts to satisfy:

$$\text{abs}(q - Q) \leq \max(\text{AbsTol}, \text{RelTol} * \text{abs}(q))$$

where `q` is the computed value of the integral and `Q` is the (unknown) exact value. The absolute and relative tolerances provide a way of trading off accuracy and computation time. Usually, the relative tolerance determines the accuracy of the integration. However if `abs(q)` is sufficiently small, the absolute tolerance determines

# integral3

---

the accuracy of the integration. You should generally specify both absolute and relative tolerances together.

- The 'iterated' method can be more effective when your function has discontinuities within the integration region. However, the best performance and accuracy occurs when you split the integral at the points of discontinuity and sum the results of multiple integrations.
- When integrating over nonrectangular regions, the best performance and accuracy occurs when any or all of the limits: `ymin`, `ymax`, `zmin`, `zmax` are function handles. Avoid setting integrand function values to zero to integrate over a nonrectangular region. If you must do this, specify 'iterated' method.
- Use the 'iterated' method when any or all of the limits: `ymin(x)`, `ymax(x)`, `zmin(x,y)`, `zmax(x,y)` are unbounded functions.
- When parameterizing anonymous functions, be aware that parameter values persist for the life of the function handle. For example, the function `fun = @(x,y,z) x + y + z + a` uses the value of `a` at the time `fun` was created. If you later decide to change the value of `a`, you must redefine the anonymous function with the new value.
- If you are specifying single-precision limits of integration, or if `fun` returns single-precision results, you may need to specify larger absolute and relative error tolerances.

## Examples

### Triple Integral with Finite Limits

Define the anonymous function  $f(x,y,z) = y \sin x + z \cos x$ .

```
fun = @(x,y,z) y.*sin(x)+z.*cos(x)
```

Integrate over the region  $0 \leq x \leq \pi$ ,  $0 \leq y \leq 1$ , and  $-1 \leq z \leq 1$ .

```
q = integral3(fun,0,pi,0,1,-1,1)
```

```
q =
```

```
2.0000
```

## Integral Over the Unit Sphere in Cartesian Coordinates

Define the anonymous function  $f(x,y,z) = x \cos y + x^2 \cos z$ .

```
fun = @(x,y,z) x.*cos(y) + x.^2.*cos(z)
```

Define the limits of integration.

```
xmin = -1;
xmax = 1;
ymin = @(x)-sqrt(1 - x.^2);
ymax = @(x) sqrt(1 - x.^2);
zmin = @(x,y)-sqrt(1 - x.^2 - y.^2);
zmax = @(x,y) sqrt(1 - x.^2 - y.^2);
```

Evaluate the definite integral with the 'tiled' method.

```
q = integral3(fun,xmin,xmax,ymin,ymax,zmin,zmax,'Method','tiled')
```

```
q =
```

```
0.7796
```

## Evaluate Improper Triple Integral of Parameterized Function

Define the anonymous parameterized function  $f(x,y,z) = 10/(x^2 + y^2 + z^2 + a)$ .

```
a = 2;
f = @(x,y,z) 10./(x.^2 + y.^2 + z.^2 + a);
```

Evaluate the triple integral over the region  $-\infty \leq x \leq 0$ ,  $-100 \leq y \leq 0$ , and  $-100 \leq z \leq 0$ .

```
format long
q1 = integral3(f,-Inf,0,-100,0,-100,0)
```

```
q1 =
```

```
2.734244598320928e+03
```

# integral3

---

Evaluate the integral again and specify accuracy to approximately 9 significant digits.

```
q2 = integral3(f,-Inf,0,-100,0,-100,0,'AbsTol', 0,'RelTol',1e-9)
```

```
q2 =
```

```
2.734244599944285e+03
```

## See Also

[integral](#) | [integral2](#) | [function\\_handle](#) | [trapz](#)

## Concepts

- “Parameterizing Functions”

**Purpose** List custom interfaces exposed by COM server object

**Syntax**  
`customlist = h.interfaces`  
`customlist = interfaces(h)`

**Description** `customlist = h.interfaces` returns cell array of strings `customlist` listing all custom interfaces implemented by the component in a specific COM server object. The server is designated by input argument `h`, the handle returned by the `actxcontrol` or `actxserver` function when creating that server.

`customlist = interfaces(h)` is an alternate syntax.

The `interfaces` function only lists the custom interfaces exposed by the object; it does not return interfaces. Use the `invoke` function to return a handle to a specific custom interface.

COM functions are available on Microsoft Windows systems only.

**See Also** `actxcontrol` | `actxserver` | `invoke` | `get (COM)`

**How To**

- “Custom Interfaces”

# interp1

---

## Purpose

1-D data interpolation (table lookup)

If you pass nonuniformly spaced points and specify the 'v5cubic' method, `interp1` issues a warning. In addition, the following syntaxes will be removed or changed in a future release:

- `interp1(..., 'cubic')`
- `pp = interp1(... 'pp')`
- `interp1(X,Y,Xq,[],...)`

For more information, and recommendations for updating your code, see “Functionality being removed or changed”.

## Syntax

```
vq = interp1(x,v,xq)
vq = interp1(x,v,xq,method)
vq = interp1(x,v,xq,method,extrapolation)
```

```
vq = interp1(v,xq)
vq = interp1(v,xq,method)
vq = interp1(v,xq,method,extrapolation)
```

```
pp = interp1(x,v,method, 'pp')
```

## Description

`vq = interp1(x,v,xq)` returns interpolated values of a 1-D function at specific query points using linear interpolation. Vector `x` contains the sample points, and `v` contains the corresponding values,  $v(x)$ . Vector `xq` contains the coordinates of the query points.

If you have multiple sets of data that are sampled at the same point coordinates, then you can pass `v` as an array. Each column of array `v` contains a different set of 1-D sample values.

`vq = interp1(x,v,xq,method)` specifies any of five strings for choosing an alternative interpolation method: 'nearest', 'linear', 'spline', 'pchip', or 'cubic'. The default method is 'linear'.



`vq = interp1(x,v,xq,method,extrapolation)` specifies a strategy for evaluating points that lie outside the domain of `x`. Set `extrapolation` to the string, 'extrap', when you want to use the `method` algorithm for extrapolation. Alternatively, you can specify a scalar value, in which case, `interp1` returns that value for all points outside the domain of `x`.

`vq = interp1(v,xq)` returns interpolated values and assumes a default set of sample point coordinates. The default points are the sequence of numbers from 1 to `n`, where `n` depends on the shape of `v`:

- When `v` is a vector, the default points are `1:length(v)`.
- When `v` is an array, the default points are `1:size(v,1)`.

Use this syntax when you are not concerned about the absolute distances between points.

`vq = interp1(v,xq,method)` specifies any of the five alternative interpolation methods and uses the default sample points.

`vq = interp1(v,xq,method,extrapolation)` specifies an extrapolation strategy and uses the default sample points.

`pp = interp1(x,v,method,'pp')` returns the piece-wise polynomial form of  $v(x)$  using the `method` algorithm.

## Input Arguments

### **x** - Sample points

vector

Sample points, specified as a row or column vector of real numbers. The values in `x` must be strictly monotonic and increasing. Furthermore, the length of `x` must conform to one of the following requirements:

- If `v` is a vector, then `length(x)` must equal `length(v)`.
- If `v` is an array, then `length(x)` must equal `size(v,1)`.

**Example:** `[1 2 3 4 5 6 7 8 9 10]`

# interp1

---

**Example:** 1:10

**Example:** [3 7 11 15 19 23 27 31]'

## Data Types

single | double

## v - Sample values

vector | matrix | array

Sample values, specified as a vector, matrix, or array of real or complex numbers. If *v* is a matrix or an array, then each column contains a separate set of 1-D values.

**Example:** rand(1,10)

**Example:** rand(10,1)

**Example:** rand(10,3)

## Data Types

single | double

**Complex Number Support:** Yes

## xq - Query points

scalar | vector | matrix | array

Query points, specified as a scalar, vector, matrix, or array of real numbers.

**Example:** 5

**Example:** 1:0.05:10

**Example:** (1:0.05:10)'

**Example:** [0 1 2 7.5 10]

## Data Types

single | double

## method - Interpolation method

'linear' (default) | 'nearest' | 'spline' | 'pchip' | 'cubic'

Interpolation method, specified as a string from the table below.

| method string | Description                                                                                                                                                                                                     | Continuity    | Comments                                                                                                                                                        |
|---------------|-----------------------------------------------------------------------------------------------------------------------------------------------------------------------------------------------------------------|---------------|-----------------------------------------------------------------------------------------------------------------------------------------------------------------|
| 'linear'      | Linear interpolation. The interpolated value at a query point is based on linear interpolation of the values at neighboring grid points in each respective dimension. This is the default interpolation method. | $C^0$         | <ul style="list-style-type: none"> <li>• Requires a minimum of 2 points.</li> <li>• Requires more memory and computation time than nearest neighbor.</li> </ul> |
| 'nearest'     | Nearest neighbor interpolation. The interpolated value at a query point is the value at the nearest sample grid point.                                                                                          | Discontinuous | <ul style="list-style-type: none"> <li>• Requires a minimum of 2 points.</li> <li>• Modest memory requirements</li> <li>• Fastest computation time</li> </ul>   |
| 'pchip'       | Shape-preserving piecewise cubic interpolation. The interpolated value at a query point is based on a shape-preserving piecewise cubic interpolation of the values at neighboring grid points.                  | $C^1$         | <ul style="list-style-type: none"> <li>• Requires at least 4 points.</li> <li>• Requires more memory and computation time than linear.</li> </ul>               |

# interp1

| method string | Description                                                                                                                                                                                            | Continuity | Comments                                                                                                                                        |
|---------------|--------------------------------------------------------------------------------------------------------------------------------------------------------------------------------------------------------|------------|-------------------------------------------------------------------------------------------------------------------------------------------------|
| 'cubic'       | Same as 'pchip'.                                                                                                                                                                                       | $C^1$      | This method currently returns the same result as 'pchip'. In a future release, this method will perform cubic convolution.                      |
| 'v5cubic'     | Cubic convolution used in MATLAB 5.                                                                                                                                                                    | $C^1$      | Points must be uniformly spaced. 'cubic' will replace 'v5cubic' in a future release.                                                            |
| 'spline'      | Spline interpolation using not-a-knot end conditions. The interpolated value at a query point is based on a cubic interpolation of the values at neighboring grid points in each respective dimension. | $C^2$      | <ul style="list-style-type: none"><li>• Requires at least 4 points.</li><li>• Requires more memory and computation time than 'pchip'.</li></ul> |

## extrapolation - Extrapolation strategy

'extrap' | scalar value

Extrapolation strategy, specified as the string, 'extrap', or a real scalar value.

- Specify 'extrap' when you want `interp1` to evaluate points outside the domain using the same method it uses for interpolation.
- Specify a scalar value when you want `interp1` to return a specific constant value for points outside the domain.

The default behavior depends on the input arguments:

- If you specify the 'pchip' or 'spline' interpolation methods, then the default behavior is 'extrap'.
- All other interpolation methods return NaN by default for query points outside the domain.

**Example:** 'extrap'

**Example:** 5

### Data Types

char | single | double

## Output Arguments

### vq - Interpolated values

scalar | vector | matrix | array

Interpolated values, returned as a scalar, vector, matrix, or array. The size of vq depends on the shape of v and xq.

| Shape of v | Shape of xq         | Size of Vq | Example                                                               |
|------------|---------------------|------------|-----------------------------------------------------------------------|
| Vector     | Vector              | size(xq)   | If size(v) = [1 100] and size(xq) = [1 500], then size(vq) = [1 500]. |
| Vector     | Matrix or N-D Array | size(xq)   | If size(v) = [1 100] and size(xq) = [50 30], then size(vq) = [50 30]. |

| Shape of <b>v</b>   | Shape of <b>xq</b>  | Size of <b>Vq</b>                                   | Example                                                                 |
|---------------------|---------------------|-----------------------------------------------------|-------------------------------------------------------------------------|
| Matrix or N-D Array | Vector              | [length(xq) size(v,2),...,size(v,3)]                | If size(v) = [100 3] and size(xq) = [1 500], then size(vq) = [500 3].   |
| Matrix or N-D Array | Matrix or N-D Array | [size(xq,1),...,size(xq,2) size(v,2),...,size(v,3)] | If size(v) = [4 5] and size(xq) = [2 3 7], then size(vq) = [2 3 7 5 6]. |

## pp - Piecewise polynomial

structure

Piecewise polynomial, returned as a structure that you can pass to the ppval function for evaluation.

## Definitions

### Strictly Monotonic

A set of values that are always increasing or decreasing, without reversals. For example, the sequence,  $a = [2\ 4\ 6\ 8]$  is strictly monotonic and increasing. The sequence,  $b = [2\ 4\ 4\ 6\ 8]$  is not strictly monotonic because there is no change in value between  $b(2)$  and  $b(3)$ . The sequence,  $c = [2\ 4\ 6\ 8\ 6]$  contains a reversal between  $c(4)$  and  $c(5)$ , so it is not monotonic at all.

## Examples

### Interpolation of Coarsely Sampled Sine Function

Define the sample points,  $x$ , and corresponding sample values,  $v$ .

```
x = 0:pi/4:2*pi;
v = sin(x);
```

Define the query points to be a finer sampling over the range of  $x$ .

```
xq = 0:pi/16:2*pi;
```

Interpolate the function at the query points and plot the result.

```
figure
vq1 = interp1(x,v,xq);
plot(x,v,'o',xq,vq1);
xlim([0 2*pi]);
title('(Default) Linear Interpolation');
```

# interp1

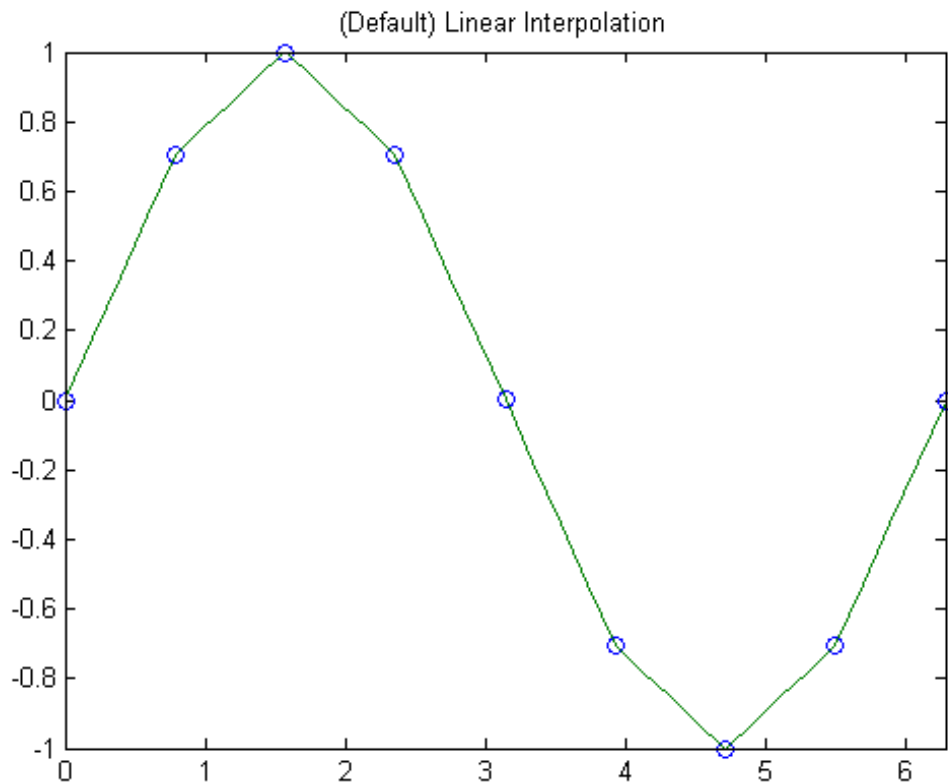

Now evaluate  $v$  at the same points using the 'spline' method.

```
figure
vq2 = interp1(x,v,xq,'spline');
plot(x,v,'o',xq,vq2);
xlim([0 2*pi]);
title('Spline Interpolation');
```



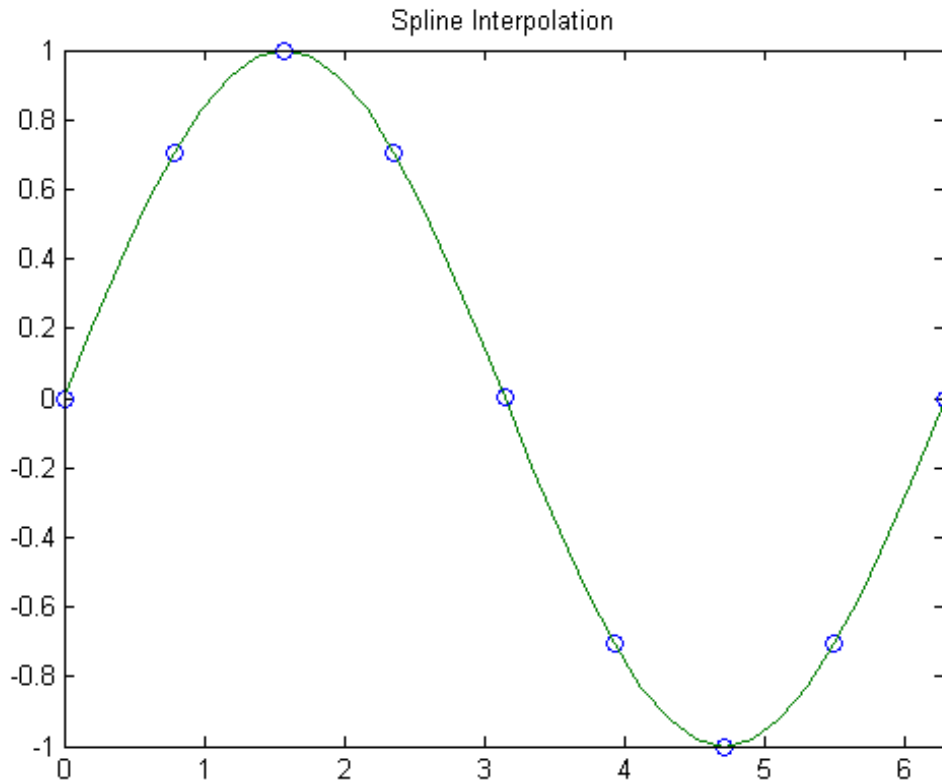

### Interpolation Without Specifying Points

Define a set of function values.

```
v = [0 1.41 2 1.41 0 -1.41 -2 -1.41 0];
```

Define a set of query points that fall between the default points, 1:9. In this case, the default points are 1:9 because v contains 9 values.

```
xq = 1.5:8.5;
```

# interp1

---

Evaluate  $v$  at  $xq$ .

```
vq = interp1(v,xq);
```

Plot the result.

```
figure
plot((1:9),v,'o',xq,vq,'*');
legend('v','vq');
```

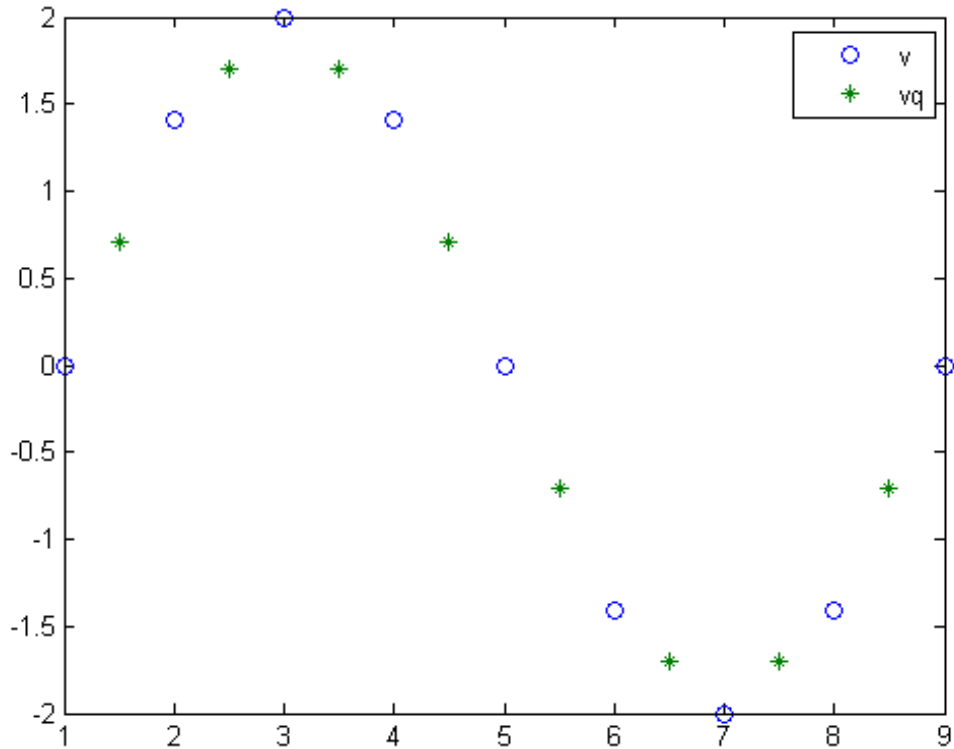

### Interpolation of Complex Values

Define a set of sample points.

```
x = 1:10;
```

Define the values of the function,  $v(x) = 5x + x^2i$ , at the sample points.

```
v = (5*x)+(x.^2*1i);
```

# interp1

---

Define the query points to be a finer sampling over the range of  $x$ .

```
xq = 1:0.25:10;
```

Interpolate  $v$  at the query points.

```
vq = interp1(x,v,xq);
```

Plot the real part of the result in red and the imaginary part in blue.

```
figure
plot(x,real(v),'*r',xq,real(vq),'-r');
hold on
plot(x,imag(v),'*b',xq,imag(vq),'-b');
```

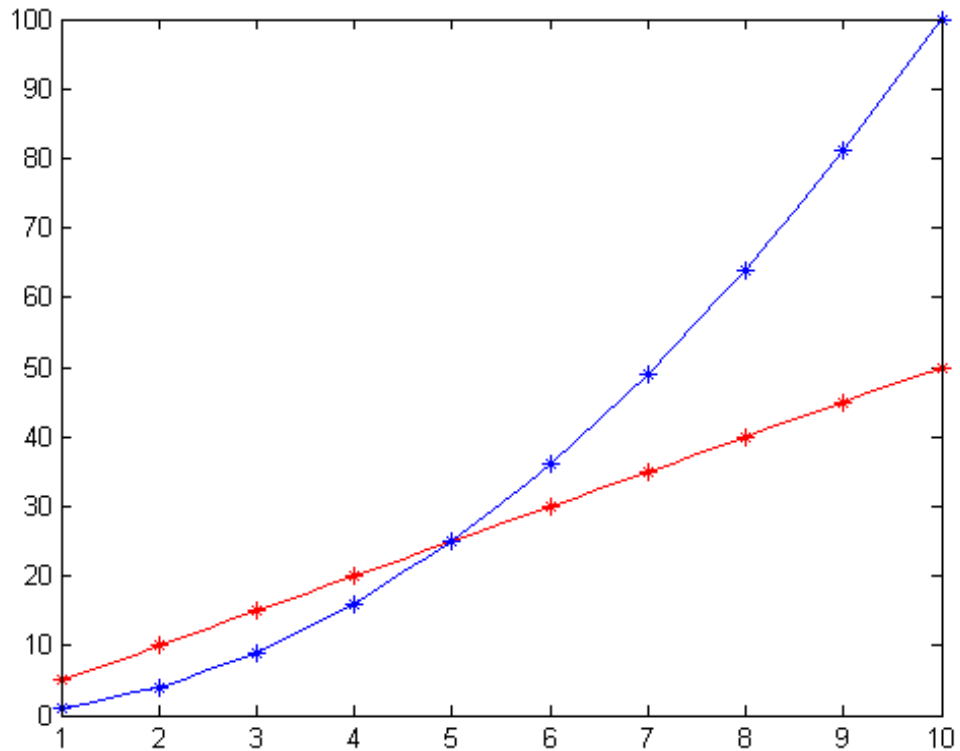

### Extrapolation Using Two Different Methods

Define the sample points,  $x$ , and corresponding sample values,  $v$ .

```
x = [1 2 3 4 5];
v = [12 16 31 10 6];
```

Specify the query points,  $xq$ , that extend beyond the domain of  $x$ .

```
xq = [0 0.5 1.5 5.5 6];
```

# interp1

---

Evaluate  $v$  at  $xq$  using the 'pchip' method.

```
vq1 = interp1(x,v,xq,'pchip')
```

```
vq1 =
```

```
 19.3684 13.6316 13.2105 7.4800 12.5600
```

Next, evaluate  $v$  at  $xq$  using the 'linear' method.

```
vq2 = interp1(x,v,xq,'linear')
```

```
vq2 =
```

```
 NaN NaN 14 NaN NaN
```

Now, use the 'linear' method with the 'extrap' option.

```
vq3 = interp1(x,v,xq,'linear','extrap')
```

```
vq3 =
```

```
 8 10 14 4 2
```

'pchip' extrapolates by default, but 'linear' does not.

## **Designate Constant Value for All Queries Outside the Domain of $x$**

Define the sample points,  $x$ , and corresponding sample values,  $v$ .

```
x = [-3 -2 -1 0 1 2 3];
v = 3*x.^2;
```

Specify the query points, xq, that extend beyond the domain of x.

```
xq = [-4 -2.5 -0.5 0.5 2.5 4];
```

Now evaluate v at xq using the 'pchip' method and assign any values outside the domain of x to the value, 27.

```
vq = interp1(x,v,xq,'pchip',27)
```

```
vq =
```

```
27.0000 18.6563 0.9375 0.9375 18.6563 27.0000
```

## Interpolate Multiple Sets of Data in One Pass

Define the sample points.

```
x = (-5:5)';
```

Sample three different parabolic functions at the points defined in x.

```
v1 = x.^2;
v2 = 2*x.^2 + 2;
v3 = 3*x.^2 + 4;
```

Create matrix v, whose columns are the vectors, v1, v2, and v3.

```
v = [v1 v2 v3];
```

Define a set of query points, xq, to be a finer sampling over the range of x.

```
xq = -5:0.1:5;
```

# interp1

Evaluate all three functions at  $x_q$  and plot the results.

```
vq = interp1(x,v,xq,'pchip');
figure
plot(x,v,'o',xq,vq);
set(gca,'XTick',-5:5);
```

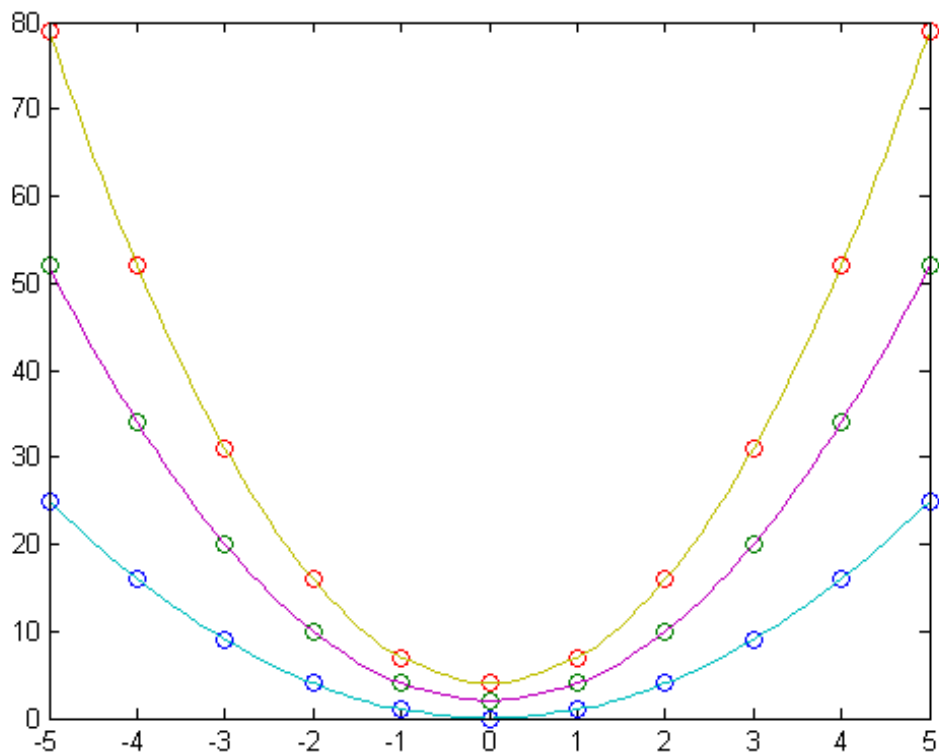

The circles in the plot represent  $v$ , and the solid lines represent  $v_q$ .



**See Also**    [interp2](#) | [interp3](#) | [interpn](#) | [griddedInterpolant](#)

# interp1q

---

**Purpose** Quick 1-D linear interpolation

---

**Note** interp1q is not recommended. Use interp1 instead.

---

**Syntax** `yi = interp1q(x,Y,xi)`

**Description** `yi = interp1q(x,Y,xi)` returns the value of the 1-D function `Y` at the points of column vector `xi` using linear interpolation. The vector `x` specifies the coordinates of the underlying interval. The length of output `yi` is equal to the length of `xi`.

`interp1q` is quicker than `interp1` on non-uniformly spaced data because it does no input checking.

For `interp1q` to work properly,

- `x` must be a monotonically increasing column vector.
- `Y` must be a column vector or matrix with `length(x)` rows.
- `xi` must be a column vector

`interp1q` returns NaN for any values of `xi` that lie outside the coordinates in `x`. If `Y` is a matrix, then the interpolation is performed for each column of `Y`, in which case `yi` is `length(xi)-by-size(Y,2)`.

## Examples **Linear Interpolation Using interp1q**

Generate a coarse sine curve and interpolate over a finer abscissa.

```
x = (0:10)';
y = sin(x);
xi = (0:.25:10)';
yi = interp1q(x,y,xi);
plot(x,y,'o',xi,yi)
```

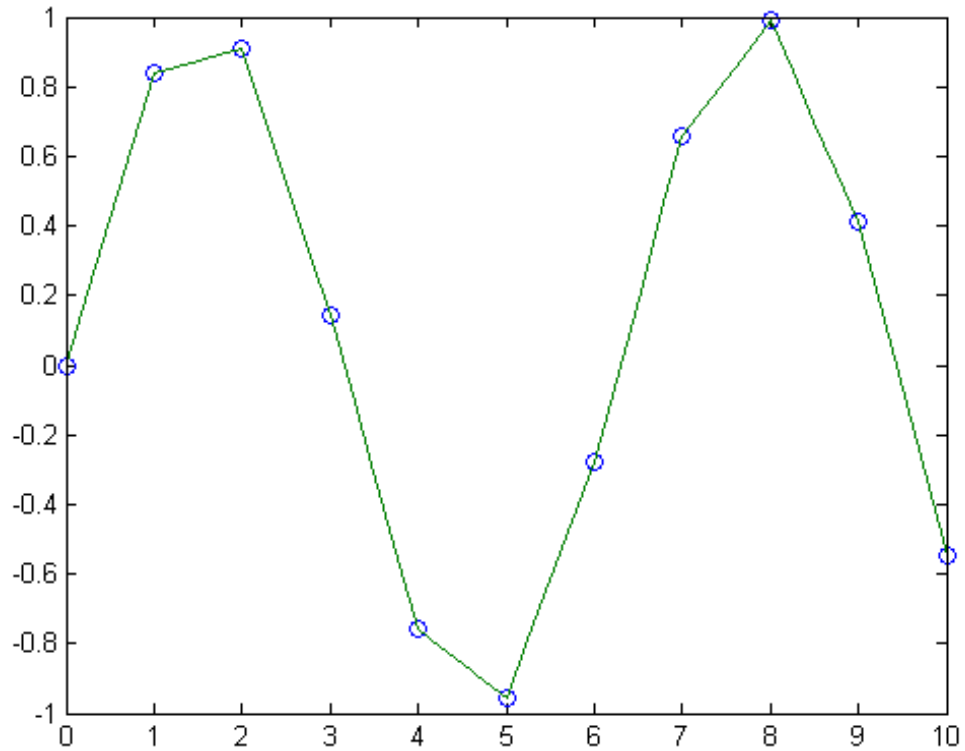
**See Also**[interp1](#) | [interp2](#) | [interp3](#) | [interpn](#)

# interp2

---

## Purpose

Interpolation for 2-D gridded data in meshgrid format

In a future release, `interp2` will not accept mixed combinations of row and column vectors for the sample and query grids. For more information, and recommendations for updating your code, see “Functionality being removed or changed”.

## Syntax

```
Vq = interp2(X,Y,V,Xq,Yq)
```

```
Vq = interp2(V,Xq,Yq)
```

```
Vq = interp2(V)
```

```
Vq = interp2(V,k)
```

```
Vq = interp2(__,method)
```

```
Vq = interp2(__,method,extrapval)
```

## Description

`Vq = interp2(X,Y,V,Xq,Yq)` returns interpolated values of a function of two variables at specific query points using linear interpolation. The results always pass through the original sampling of the function. `X` and `Y` contain the coordinates of the sample points. `V` contains the corresponding function values at each sample point. `Xq` and `Yq` contain the coordinates of the query points.

`Vq = interp2(V,Xq,Yq)` assumes a default grid of sample points. The default grid points cover the rectangular region, `X=1:n` and `Y=1:m`, where `[m,n] = size(V)`. Use this syntax to when you want to conserve memory and are not concerned about the absolute distances between points.

`Vq = interp2(V)` returns the interpolated values on a refined grid formed by dividing the interval between sample values once in each dimension.

`Vq = interp2(V,k)` returns the interpolated values on a refined grid formed by repeatedly dividing the intervals `k` times in each dimension.

`Vq = interp2(___,method)` specifies an optional, trailing input argument that you can pass with any of the previous syntaxes. The `method` argument can be any of the following strings that specify alternative interpolation methods: 'linear', 'nearest', 'cubic', or 'spline'. The default method is 'linear'.

`Vq = interp2(___,method,extrapval)` also specifies `extrapval`, a scalar value that is assigned to all queries that lie outside the domain of the sample points. If you omit the `extrapval` argument, then `interp2` returns NaN values for queries outside the domain of the sample points.

## Input Arguments

### X,Y - Sample grid points

matrices | vectors

Sample grid points, specified as real matrices or vectors.

- If `X` and `Y` are matrices, then they contain the coordinates of a full grid (in `meshgrid` format). Use the `meshgrid` function to create the `X` and `Y` matrices together. Both matrices must be the same size.
- If `X` and `Y` are vectors, then they are treated as a grid vectors. The values in both vectors must be strictly monotonic and increasing.

**Example:** `[X,Y] = meshgrid(1:30,-10:10)`

### Data Types

single | double

### V - Sample values

matrix

Sample values, specified as a real or complex matrix. The size requirements for `V` depend on the size of `X` and `Y`.

- If `X` and `Y` are matrices representing a full grid (in `meshgrid` format), then `V` must be the same size as `X` and `Y`.
- If `X` and `Y` are grid vectors, then `V` must be a matrix containing `length(Y)` rows and `length(X)` columns.

**Example:** `rand(10,10)`

## Data Types

single | double

**Complex Number Support:** Yes

## Xq,Yq - Query points

scalars | vectors | matrices | arrays

Query points, specified as a real scalars, vectors, matrices, or arrays.

- If Xq and Yq are scalars, then they are the coordinates of a single query point.
- If Xq and Yq are vectors of different orientations, then Xq and Yq are treated as grid vectors.
- If Xq and Yq are vectors of the same size and orientation, then Xq and Yq are treated as scattered points in 2-D space.
- If Xq and Yq are matrices, then they represent either a full grid of query points (in `meshgrid` format) or scattered points.
- If Xq and Yq are N-D arrays, then they represent scattered points in 2-D space.

**Example:** `[Xq,Yq] = meshgrid((1:0.1:10),(-5:0.1:0))`

## Data Types

single | double

## k - Refinement factor

1 (default) | real, nonnegative, integer scalar

Refinement factor, specified as a real, nonnegative, integer scalar. This value specifies the number of times to repeatedly divide the intervals of the refined grid in each dimension. This results in  $2^k - 1$  interpolated points between sample values.

If k is 0, then Vq is the same as V.

`interp2(V,1)` is the same as `interp2(V)`.

The following illustration shows the placement of interpolated values (in red) among nine sample values (in black) for  $k=2$ .

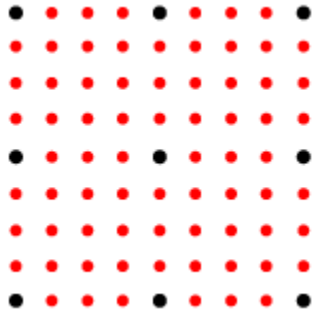

Example: `interp2(V,2)`

### Data Types

single | double

### method - Interpolation method

'linear' (default) | 'nearest' | 'cubic' | 'spline'

Interpolation method, specified as a string from this table.

| Method    | Description                                                                                                                                                                               | Continuity    | Comments                                                                                                                                           |
|-----------|-------------------------------------------------------------------------------------------------------------------------------------------------------------------------------------------|---------------|----------------------------------------------------------------------------------------------------------------------------------------------------|
| 'linear'  | The interpolated value at a query point is based on linear interpolation of the values at neighboring grid points in each respective dimension. This is the default interpolation method. | $C^0$         | <ul style="list-style-type: none"> <li>Requires at least two grid points in each dimension</li> <li>Requires more memory than 'nearest'</li> </ul> |
| 'nearest' | The interpolated value at a query point is the value                                                                                                                                      | Discontinuous | <ul style="list-style-type: none"> <li>Requires two grid points in each dimension.</li> </ul>                                                      |

# interp2

(Continued)

| Method   | Description                                                                                                                                                                                                                    | Continuity | Comments                                                                                                                                                                                                                                                                                        |
|----------|--------------------------------------------------------------------------------------------------------------------------------------------------------------------------------------------------------------------------------|------------|-------------------------------------------------------------------------------------------------------------------------------------------------------------------------------------------------------------------------------------------------------------------------------------------------|
|          | at the nearest sample grid point.                                                                                                                                                                                              |            | <ul style="list-style-type: none"><li>• Fastest computation with modest memory requirements</li></ul>                                                                                                                                                                                           |
| 'cubic'  | The interpolated value at a query point is based on a cubic interpolation of the values at neighboring grid points in each respective dimension. The interpolation is based on a cubic convolution.                            | $C^1$      | <ul style="list-style-type: none"><li>• Grid must have uniform spacing in each dimension, but the spacing does not have to be the same for all dimensions</li><li>• Requires at least four points in each dimension</li><li>• Requires more memory and computation time than 'linear'</li></ul> |
| 'spline' | The interpolated value at a query point is based on a cubic interpolation of the values at neighboring grid points in each respective dimension. The interpolation is based on a cubic spline using not-a-knot end conditions. | $C^2$      | <ul style="list-style-type: none"><li>• Requires four points in each dimension</li><li>• Requires more memory and computation time than 'cubic'</li></ul>                                                                                                                                       |

**extrapval - Function value outside domain of X and Y**



scalar

Function value outside domain of X and Y, specified as a real or complex scalar. `interp2` returns this constant value for all points outside the domain of X and Y.

**Example:** 5

**Example:** 5+1i

### Data Types

single | double

**Complex Number Support:** Yes

## Output Arguments

### Vq - Interpolated values

scalar | vector | matrix

Interpolated values, returned as a real or complex scalar, vector, or matrix. The size and shape of Vq depends on the syntax you use and, in some cases, the size and value of the input arguments.

| Syntaxes                                                                                                                                                          | Special Conditions                                  | Size of Vq                                       | Example                                                                                                               |
|-------------------------------------------------------------------------------------------------------------------------------------------------------------------|-----------------------------------------------------|--------------------------------------------------|-----------------------------------------------------------------------------------------------------------------------|
| <code>interp2(X,Y,V,Xq,Yq)</code><br><code>interp2(V,Xq,Yq)</code><br>and variations of these syntaxes that include <code>method</code> or <code>extrapval</code> | Xq, Yq are scalars                                  | Scalar                                           | <code>size(Vq) = [1 1]</code><br>when you pass Xq and Yq as scalars.                                                  |
| Same as above                                                                                                                                                     | Xq, Yq are vectors of the same size and orientation | Vector of same size and orientation as Xq and Yq | If <code>size(Xq) = [100 1]</code><br>and <code>size(Yq) = [100 1]</code> ,<br>then <code>size(Vq) = [100 1]</code> . |

# interp2

| Syntaxes                                                                                                           | Special Conditions                             | Size of Vq                                                                                                                                                | Example                                                                                                   |
|--------------------------------------------------------------------------------------------------------------------|------------------------------------------------|-----------------------------------------------------------------------------------------------------------------------------------------------------------|-----------------------------------------------------------------------------------------------------------|
| Same as above                                                                                                      | Xq, Yq are vectors of mixed orientation        | Matrix in which the number of rows is $\text{length}(Yq)$ , and the number of columns is $\text{length}(Xq)$                                              | If $\text{size}(Xq) = [1 \ 100]$ and $\text{size}(Yq) = [50 \ 1]$ , then $\text{size}(Vq) = [50 \ 100]$ . |
| Same as above                                                                                                      | Xq, Yq are matrices or arrays of the same size | Matrix or array of the same size as Xq and Yq                                                                                                             | If $\text{size}(Xq) = [50 \ 25]$ and $\text{size}(Yq) = [50 \ 25]$ , then $\text{size}(Vq) = [50 \ 25]$ . |
| <code>interp2(V,k)</code> and variations of this syntax that include <code>method</code> or <code>extrapval</code> | None                                           | Matrix in which the number of rows is:<br>$2^k * (\text{size}(V,1) - 1) + 1$ ,<br><br>and the number of columns is:<br>$2^k * (\text{size}(V,2) - 1) + 1$ | If $\text{size}(V) = [10 \ 20]$ and $k = 2$ , then $\text{size}(Vq) = [37 \ 77]$ .                        |

## Definitions **Strictly Monotonic**

A set of values that are always increasing or decreasing, without reversals. For example, the sequence,  $a = [2 \ 4 \ 6 \ 8]$  is strictly monotonic and increasing. The sequence,  $b = [2 \ 4 \ 4 \ 6 \ 8]$  is not strictly monotonic because there is no change in value between  $b(2)$  and  $b(3)$ . The sequence,  $c = [2 \ 4 \ 6 \ 8 \ 6]$  contains a reversal between  $c(4)$  and  $c(5)$ , so it is not monotonic at all.

## **Full Grid (in meshgrid Format)**

For `interp2`, the full grid is a pair of matrices whose elements represent a grid of points over a rectangular region. One matrix contains the  $x$ -coordinates, and the other matrix contains the  $y$ -coordinates. The

values in the  $x$ -matrix are strictly monotonic and increasing along the rows. The values along its columns are constant. The values in the  $y$ -matrix are strictly monotonic and increasing along the columns. The values along its rows are constant. Use the `meshgrid` function to create a full grid that you can pass to `interp2`.

For example, the following code creates a full grid for the region,  $-1 \leq x \leq 3$  and  $1 \leq y \leq 4$ :

```
[X,Y] = meshgrid(-1:3,(1:4))
```

X =

```
-1 0 1 2 3
-1 0 1 2 3
-1 0 1 2 3
-1 0 1 2 3
```

Y =

```
1 1 1 1 1
2 2 2 2 2
3 3 3 3 3
4 4 4 4 4
```

### Grid Vectors

For `interp2`, grid vectors consist of a pair of mixed-orientation vectors that define the  $x$ - and  $y$ -coordinates in a grid. One vector is a row vector, and the other is a column vector.

For example, the following code creates the grid vectors that specify the region,  $-1 \leq x \leq 3$  and  $1 \leq y \leq 4$ :

```
x = -1:3;
y = (1:4)';
```

## Scattered Points

For `interp2`, scattered points consist of a pair of arrays that define a collection of points scattered in 2-D space. One array contains the  $x$ -coordinates, and the other contains the  $y$ -coordinates.

For example, the following code specifies the points, (2,7), (5,3), (4,1), and (10,9):

```
x = [2 5; 4 10];
y = [7 3; 1 9];
```

## Examples

### Interpolate Over a Grid Using Default Method

Coarsely sample the `peaks` function.

```
[X,Y] = meshgrid(-3:3);
V = peaks(X,Y);
```

Plot the coarse sampling.

```
figure
surf(X,Y,V)
title('Original Sampling');
```

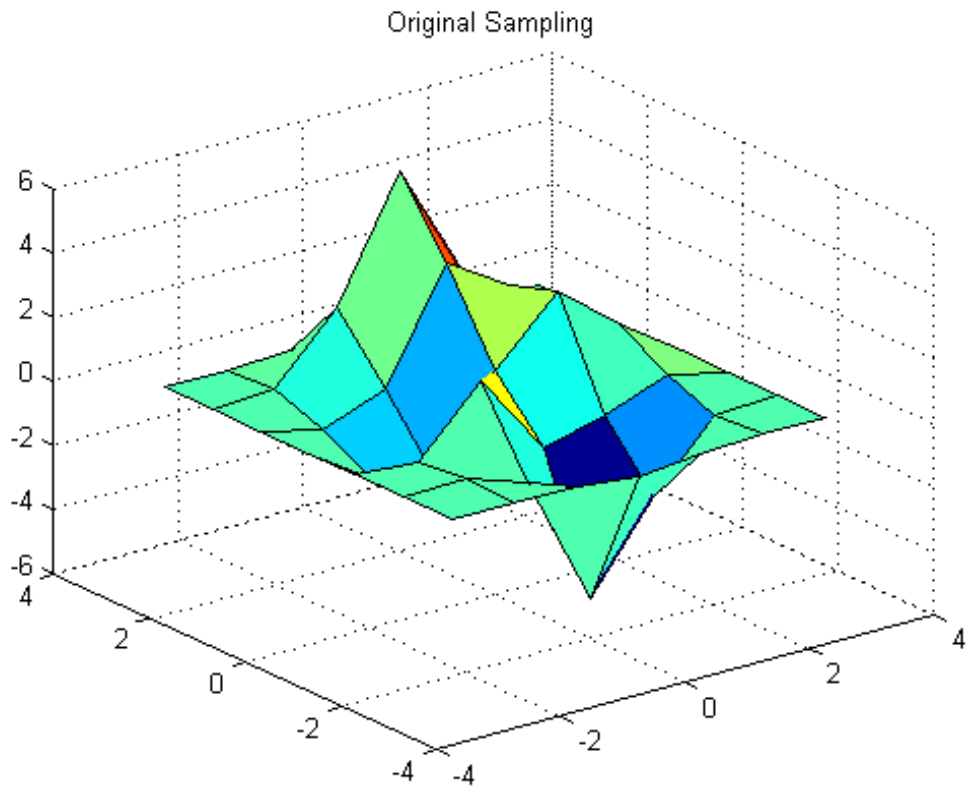

Create the query grid with spacing of 0.25.

```
[Xq,Yq] = meshgrid(-3:0.25:3);
```

Interpolate at the query points.

```
Vq = interp2(X,Y,V,Xq,Yq);
```

Plot the result.

```
figure
surf(Xq,Yq,Vq);
title('Linear Interpolation Using Finer Grid');
```

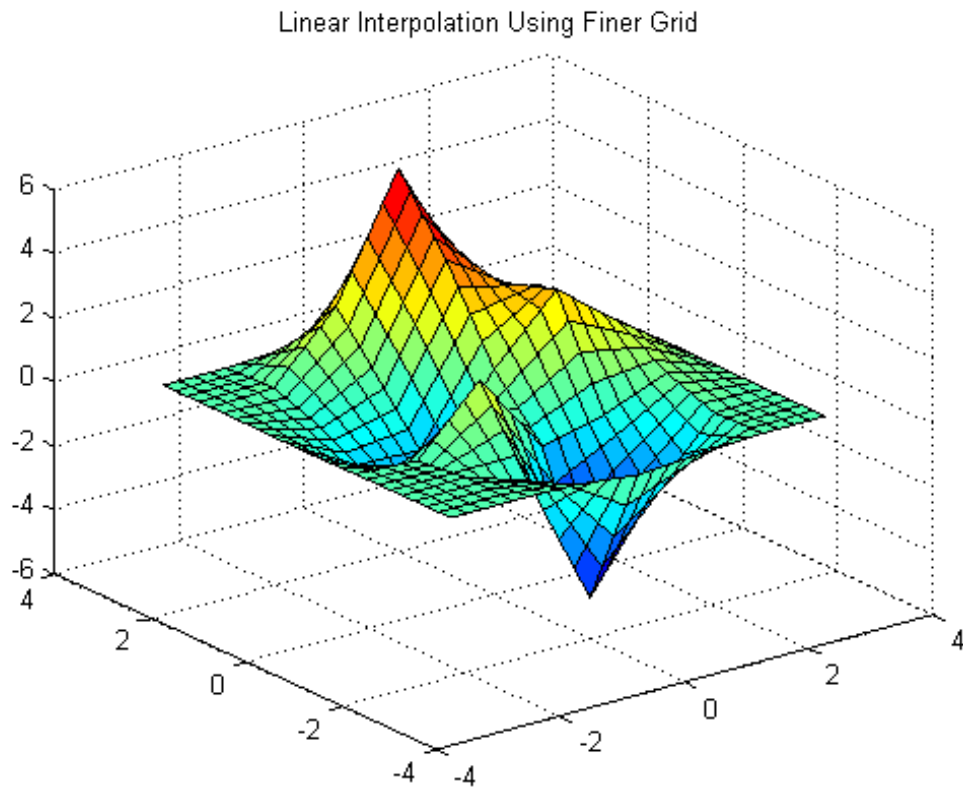

## Interpolate Over a Grid Using Cubic Method

Coarsely sample the peaks function.

```
[X,Y] = meshgrid(-3:3);
V = peaks(7);
```

Plot the coarse sampling.

```
figure
surf(X,Y,V)
title('Original Sampling');
```

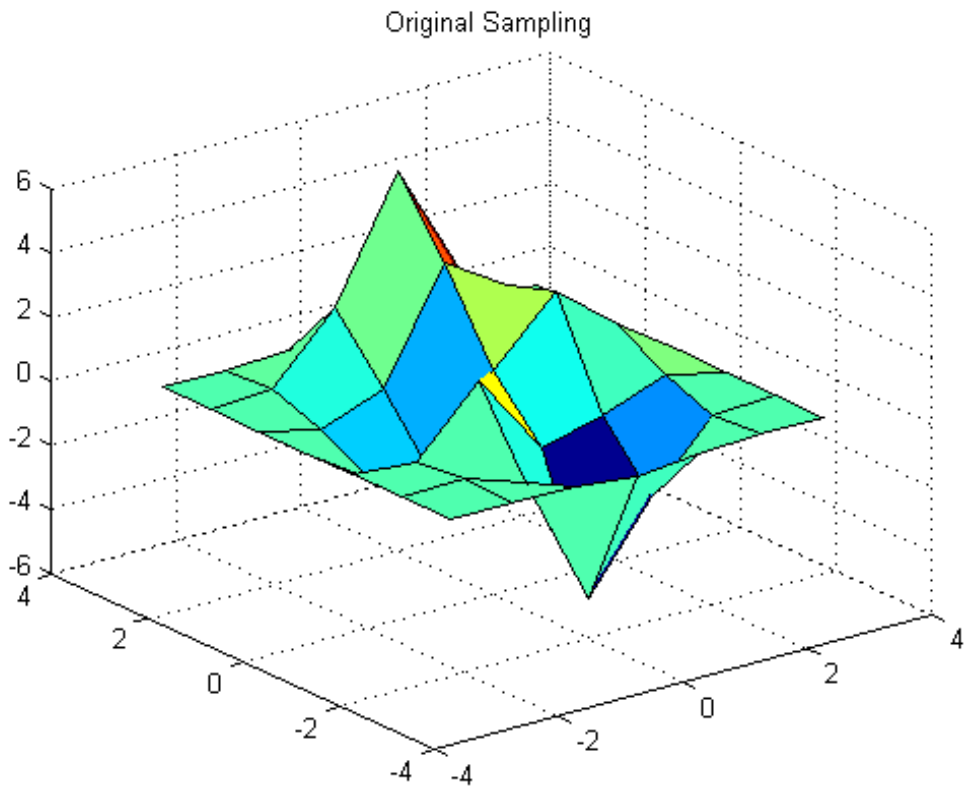

Create the query grid with spacing of 0.25.

```
[Xq,Yq] = meshgrid(-3:0.25:3);
```

# interp2

---

Interpolate at the query points, and specify cubic interpolation.

```
Vq = interp2(X,Y,V,Xq,Yq,'cubic');
```

Plot the result.

```
figure
surf(Xq,Yq,Vq);
title('Cubic Interpolation Over Finer Grid');
```



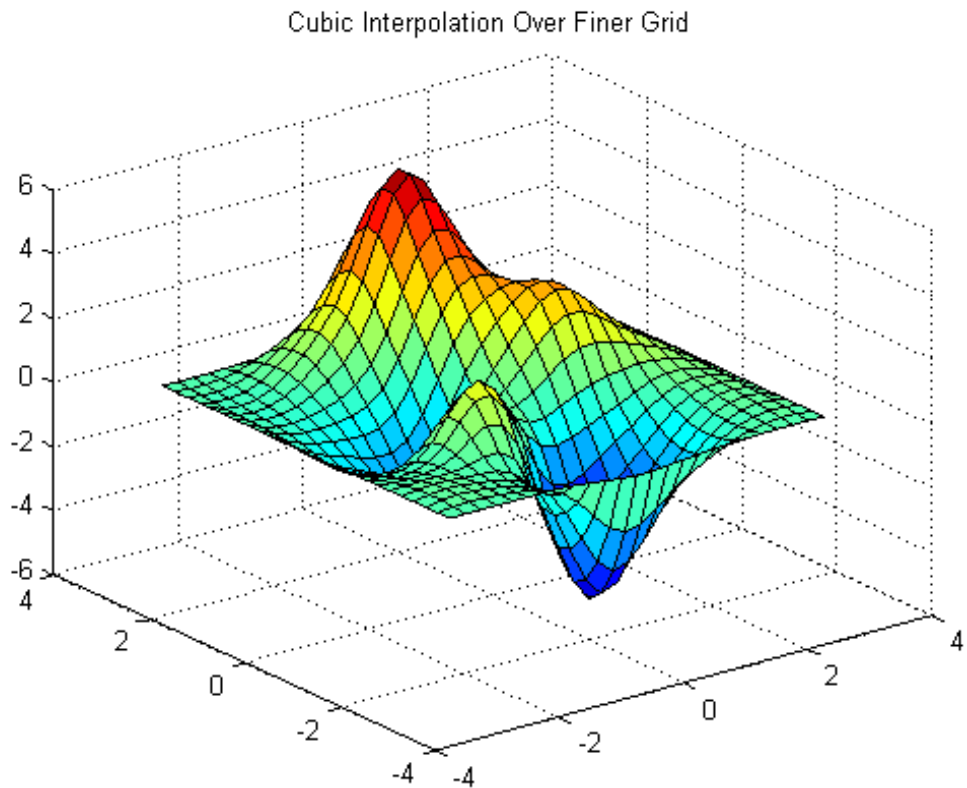

### Refine Grayscale Image

Load some image data into the workspace.

```
load clown
```

Isolate a small region of the image and cast it to single.

```
V = single(X(1:124,75:225));
```

## interp2

---

Display the image.

```
figure
imagesc(V);
colormap gray
axis image
axis off
title('Original Image');
```

Original Image



Insert interpolated values by repeatedly dividing the intervals between points of the refined grid five times in each dimension.

```
Vq = interp2(V,5);
```

Display the result.

```
figure
imagesc(Vq);
colormap gray
axis image
axis off
title('Linear Interpolation');
```

Linear Interpolation



## Evaluate Outside the Domain of X and Y

Coarsely sample a function over the range,  $[-2, 2]$  in both dimensions.

```
[X,Y] = meshgrid(-2:0.75:2);
R = sqrt(X.^2 + Y.^2)+ eps;
V = sin(R)./(R);
```

Plot the coarse sampling.

```
figure
surf(X,Y,V)
xlim([-4 4]);
ylim([-4 4]);
title('Original Sampling');
```

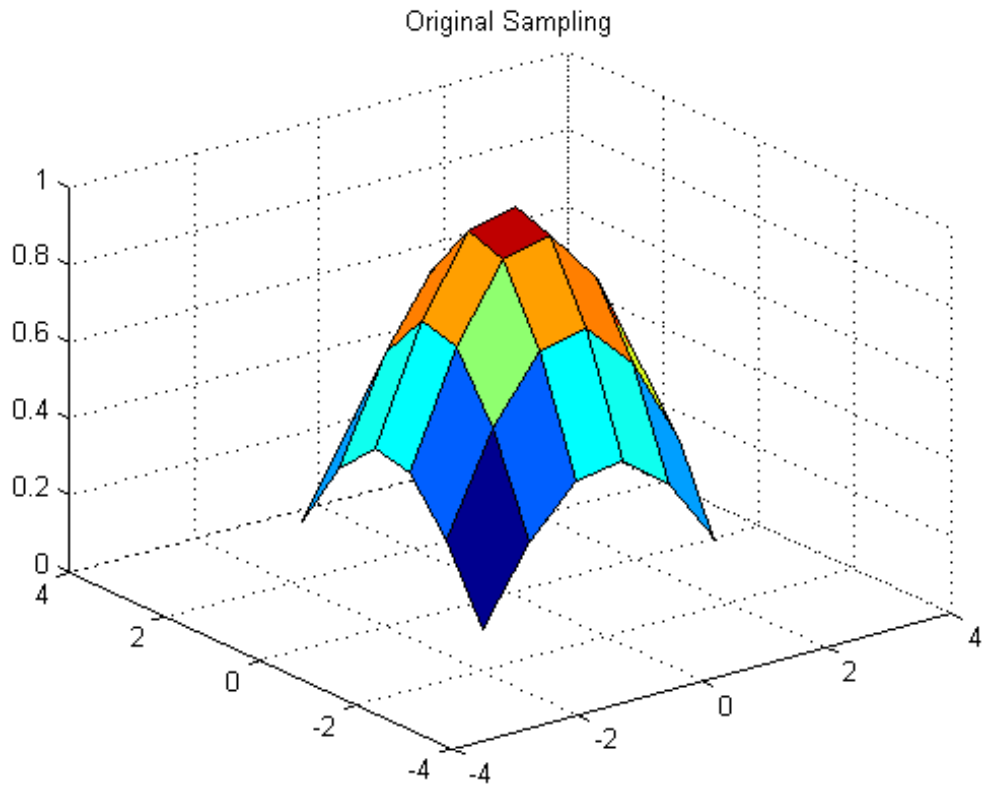

Create the query grid that extends beyond the domain of X and Y.

```
[Xq,Yq] = meshgrid(-3:0.2:3);
```

# interp2

---

Perform cubic interpolation within the domain of X and Y, and assign all queries that fall outside to zero.

```
Vq = interp2(X,Y,V,Xq,Yq, 'cubic',0);
```

Plot the result.

```
figure
surf(Xq,Yq,Vq);
title('Cubic Interpolation with Vq=0 Outside Domain of X and Y');
```

Cubic Interpolation with Vq=0 Outside Domain of X and Y

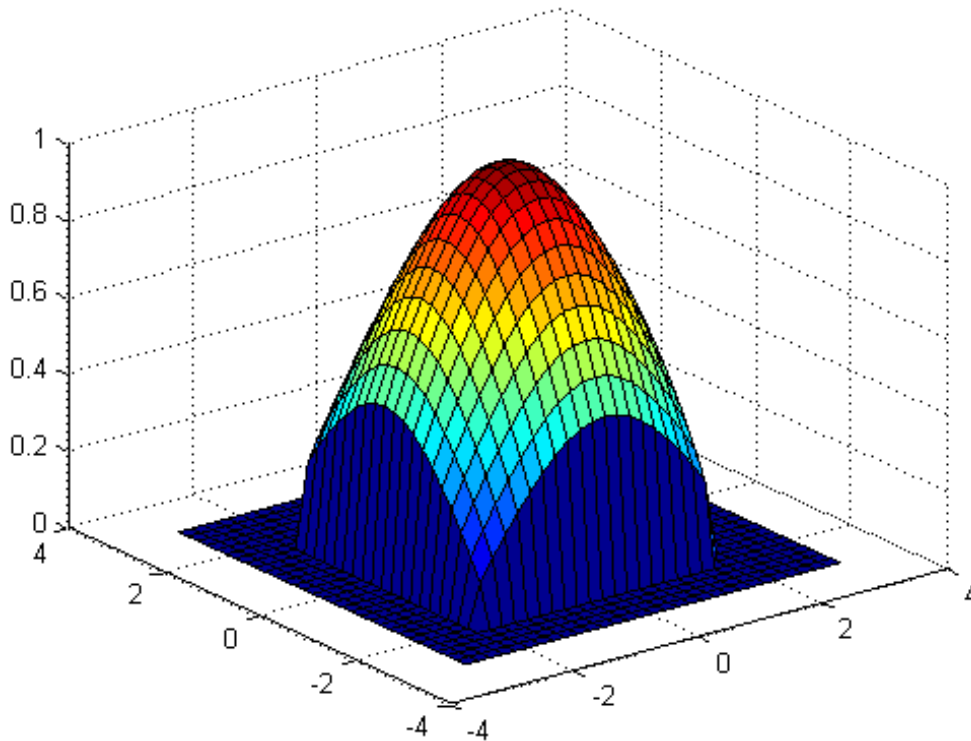

## See Also

`griddata` | `interp1` | `interp3` | `interp` | `meshgrid` | `griddedInterpolant`

# interp3

---

## Purpose

Interpolation for 3-D gridded data in meshgrid format

In a future release, `interp3` will not accept mixed combinations of row and column vectors for the sample and query grids. For more information, and recommendations for updating your code, see “Functionality being removed or changed”.

## Syntax

```
Vq = interp3(X,Y,Z,V,Xq,Yq,Zq)
```

```
Vq = interp3(V,Xq,Yq,Zq)
```

```
Vq = interp3(V)
```

```
Vq = interp3(V,k)
```

```
Vq = interp3(__,method)
```

```
Vq = interp3(__,method,extrapval)
```

## Description

`Vq = interp3(X,Y,Z,V,Xq,Yq,Zq)` returns interpolated values of a function of three variables at specific query points using linear interpolation. The results always pass through the original sampling of the function. `X`, `Y`, and `Z` contain the coordinates of the sample points. `V` contains the corresponding function values at each sample point. `Xq`, `Yq`, and `Zq` contain the coordinates of the query points.

`Vq = interp3(V,Xq,Yq,Zq)` assumes a default grid of sample points. The default grid points cover the region, `X=1:n`, `Y=1:m`, `Z=1:p`, where `[m,n,p] = size(V)`. Use this syntax when you want to conserve memory and are not concerned about the absolute distances between points.

`Vq = interp3(V)` returns the interpolated values on a refined grid formed by dividing the interval between sample values once in each dimension.

`Vq = interp3(V,k)` returns the interpolated values on a refined grid formed by repeatedly dividing the intervals `k` times in each dimension.



`Vq = interp3( ____, method)` specifies an optional, trailing input argument that you can pass with any of the previous syntaxes. The `method` argument can be any of the following strings that specify alternative interpolation methods: 'linear', 'nearest', 'cubic', or 'spline'. The default method is 'linear'.

`Vq = interp3( ____, method, extrapval)` also specifies `extrapval`, a scalar value that is assigned to all queries that lie outside the domain of the sample points. If you omit the `extrapval` argument, then `interp3` returns NaN values for queries outside the domain of the sample points.

## Input Arguments

### **X,Y,Z - Sample grid points**

arrays | vectors

Sample grid points, specified as real arrays or vectors.

- If X, Y, and Z are arrays, then they contain the coordinates of a full grid (in `meshgrid` format). Use the `meshgrid` function to create the X, Y, and Z arrays together. These arrays must be the same size.
- If X, Y, and Z are vectors, then they are treated as a grid vectors. The values in these vectors must be strictly monotonic and increasing.

**Example:** `[X,Y,Z] = meshgrid(1:30, -10:10, 1:5)`

### **Data Types**

single | double

### **V - Sample values**

array

Sample values, specified as a real or complex array. The size requirements for V depend on the size of X, Y, and Z.

- If X, Y, and Z are arrays representing a full grid (in `meshgrid` format), then the size of V matches the size of X, Y, or Z.
- If X, Y, and Z are grid vectors, then `size(V) = [length(Y) length(X) length(Z)]`.

**Example:** `rand(10, 10, 10)`

## Data Types

single | double

**Complex Number Support:** Yes

## Xq,Yq,Zq - Query points

scalars | vectors | arrays

Query points, specified as a real scalars, vectors, or arrays.

- If Xq, Yq, and Zq are scalars, then they are the coordinates of a single query point in  $R^3$ .
- If Xq, Yq, and Zq are vectors of different orientations, then Xq, Yq, and Zq are treated as grid vectors in  $R^3$ .
- If Xq, Yq, and Zq are vectors of the same size and orientation, then Xq, Yq, and Zq are treated as scattered points in  $R^3$ .
- If Xq, Yq, and Zq are arrays of the same size, then they represent either a full grid of query points (in `meshgrid` format) or scattered points in  $R^3$ .

**Example:** `[Xq,Yq,Zq] = meshgrid((1:0.1:10),(-5:0.1:0),3:5)`

## Data Types

single | double

## k - Refinement factor

1 (default) | real, nonnegative, integer scalar

Refinement factor, specified as a real, nonnegative, integer scalar. This value specifies the number of times to repeatedly divide the intervals of the refined grid in each dimension. This results in  $2^k - 1$  interpolated points between sample values.

If k is 0, then Vq is the same as V.

`interp3(V,1)` is the same as `interp3(V)`.

The following illustration depicts  $k=2$  in one plane of  $R^3$ . There are 72 interpolated values in red and 9 sample values in black.

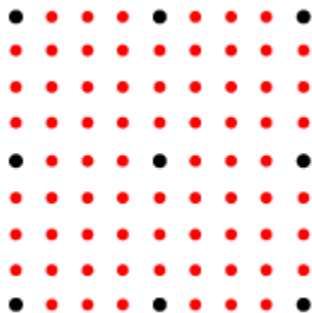

Example: `interp3(V,2)`

### Data Types

single | double

### method - Interpolation method

'linear' (default) | 'nearest' | 'cubic' | 'spline'

Interpolation method, specified as a string from this table.

| Method    | Description                                                                                                                                                                               | Continuity    | Comments                                                                                                                                           |
|-----------|-------------------------------------------------------------------------------------------------------------------------------------------------------------------------------------------|---------------|----------------------------------------------------------------------------------------------------------------------------------------------------|
| 'linear'  | The interpolated value at a query point is based on linear interpolation of the values at neighboring grid points in each respective dimension. This is the default interpolation method. | $C^0$         | <ul style="list-style-type: none"> <li>Requires at least two grid points in each dimension</li> <li>Requires more memory than 'nearest'</li> </ul> |
| 'nearest' | The interpolated value at a query point is the value                                                                                                                                      | Discontinuous | <ul style="list-style-type: none"> <li>Requires two grid points in each dimension</li> </ul>                                                       |

# interp3

(Continued)

| Method   | Description                                                                                                                                                                                                                    | Continuity | Comments                                                                                                                                                                                                                                                                                        |
|----------|--------------------------------------------------------------------------------------------------------------------------------------------------------------------------------------------------------------------------------|------------|-------------------------------------------------------------------------------------------------------------------------------------------------------------------------------------------------------------------------------------------------------------------------------------------------|
|          | at the nearest sample grid point.                                                                                                                                                                                              |            | <ul style="list-style-type: none"><li>• Fastest computation with modest memory requirements</li></ul>                                                                                                                                                                                           |
| 'cubic'  | The interpolated value at a query point is based on a cubic interpolation of the values at neighboring grid points in each respective dimension. The interpolation is based on a cubic convolution.                            | $C^1$      | <ul style="list-style-type: none"><li>• Grid must have uniform spacing in each dimension, but the spacing does not have to be the same for all dimensions</li><li>• Requires at least four points in each dimension</li><li>• Requires more memory and computation time than 'linear'</li></ul> |
| 'spline' | The interpolated value at a query point is based on a cubic interpolation of the values at neighboring grid points in each respective dimension. The interpolation is based on a cubic spline using not-a-knot end conditions. | $C^2$      | <ul style="list-style-type: none"><li>• Requires four points in each dimension</li><li>• Requires more memory and computation time than 'cubic'</li></ul>                                                                                                                                       |

**extrapval - Function value outside domain of X, Y, and Z**

scalar

Function value outside domain of X, Y, and Z, specified as a real or complex scalar. `interp3` returns this constant value for all points outside the domain of X, Y, and Z.

**Example:** 5

**Example:** 5+1i

### Data Types

single | double

**Complex Number Support:** Yes

## Output Arguments

### Vq - Interpolated values

scalar | vector | array

Interpolated values, returned as a real or complex scalar, vector, or array. The size and shape of Vq depends on the syntax you use and, in some cases, the size and value of the input arguments.

| Syntaxes                                                                                                                                                              | Special Conditions                                           | Size of Vq                                            | Example                                                                                                                                                 |
|-----------------------------------------------------------------------------------------------------------------------------------------------------------------------|--------------------------------------------------------------|-------------------------------------------------------|---------------------------------------------------------------------------------------------------------------------------------------------------------|
| <code>interp3(X,Y,Z,V,Xq,Yq,Zq)</code> , <code>interp3(V,Xq,Yq,Zq)</code> and variations of these syntaxes that include <code>method</code> or <code>extrapval</code> | Xq, Yq, and Zq are scalars.                                  | Scalar                                                | <code>size(Vq) = [1 1]</code> when you pass Xq, Yq, and Zq as scalars.                                                                                  |
| Same as above                                                                                                                                                         | Xq, Yq, and Zq are vectors of the same size and orientation. | Vector of same size and orientation as Xq, Yq, and Zq | If <code>size(Xq) = [100 1]</code> , and <code>size(Yq) = [100 1]</code> , and <code>size(Zq) = [100 1]</code> , then <code>size(Vq) = [100 1]</code> . |

# interp3

| Syntaxes                                                                    | Special Conditions                               | Size of Vq                                                                                   | Example                                                                                                                                           |
|-----------------------------------------------------------------------------|--------------------------------------------------|----------------------------------------------------------------------------------------------|---------------------------------------------------------------------------------------------------------------------------------------------------|
| Same as above                                                               | Xq, Yq, and Zq are vectors of mixed orientation. | $\text{size}(Vq) = [\text{length}(Y) \ \text{length}(X) \ \text{length}(Z)]$                 | If $\text{size}(Xq) = [1 \ 100]$ , and $\text{size}(Yq) = [50 \ 1]$ , and $\text{size}(Zq) = [1 \ 5]$ , then $\text{size}(Vq) = [50 \ 100 \ 5]$ . |
| Same as above                                                               | Xq, Yq, and Zq are arrays of the same size.      | Array of the same size as Xq, Yq, and Zq                                                     | If $\text{size}(Xq) = [50 \ 25]$ , and $\text{size}(Yq) = [50 \ 25]$ , and $\text{size}(Zq) = [50 \ 25]$ , then $\text{size}(Vq) = [50 \ 25]$ .   |
| interp3(V,k) and variations of this syntax that include method or extrapval | None                                             | Array in which the length of the <i>i</i> th dimension is $2^k * (\text{size}(V,i) - 1) + 1$ | If $\text{size}(V) = [10 \ 12 \ 5]$ , and $k = 3$ , then $\text{size}(Vq) = [73 \ 89 \ 33]$ .                                                     |

## Definitions **Strictly Monotonic**

A set of values that are always increasing or decreasing, without reversals. For example, the sequence,  $a = [2 \ 4 \ 6 \ 8]$  is strictly monotonic and increasing. The sequence,  $b = [2 \ 4 \ 4 \ 6 \ 8]$  is not strictly monotonic because there is no change in value between  $b(2)$  and  $b(3)$ . The sequence,  $c = [2 \ 4 \ 6 \ 8 \ 6]$  contains a reversal between  $c(4)$  and  $c(5)$ , so it is not monotonic at all.

## **Full Grid (in meshgrid Format)**

For interp3, a full grid consists of three arrays whose elements represent a grid of points that define a region in  $R^3$ . The first array contains the *x*-coordinates, the second array contains the *y*-coordinates, and the third array contains the *z*-coordinates.

The values in the  $x$ -array are strictly monotonic, increasing, and vary along the second dimension. The values in the  $y$ -array are strictly monotonic, increasing, and vary along the first dimension. The values in the  $z$ -array are strictly monotonic, increasing, and vary along the third dimension. Use the `meshgrid` function to create a full grid that you can pass to `interp3`.

### Grid Vectors

For `interp3`, grid vectors consist of three vectors of mixed-orientation that define the points on a grid in  $R^3$ .

For example, the following code creates the grid vectors for the region,  $1 \leq x \leq 3$ ,  $4 \leq y \leq 5$ , and  $6 \leq z \leq 8$ :

```
x = 1:3;
y = (4:5)';
z = 6:8;
```

### Scattered Points

For `interp3`, scattered points consist of three arrays or vectors,  $Xq$ ,  $Yq$ , and  $Zq$ , that define a collection of points scattered in  $R^3$ . The  $i$ th array contains the coordinates in the  $i$ th dimension.

For example, the following code specifies the points, (1, 19, 10), (6, 40, 1), (15, 33, 22), and (0, 61, 13).

```
Xq = [1 6; 15 0];
Yq = [19 40; 33 61];
Zq = [10 1; 22 13];
```

## Examples

### Interpolate Using Default Method

Load the points and values of the flow function, sampled at 10 points in each dimension.

```
[X,Y,Z,V] = flow(10);
```

# interp3

---

The flow function returns the grid in the arrays, X, Y, Z. The grid covers the region,  $0.1 \leq X \leq 10$ ,  $-3 \leq Y \leq 3$ ,  $-3 \leq Z \leq 3$ , and the spacing is  $\Delta X = 0.5$ ,  $\Delta Y = 0.7$ , and  $\Delta Z = 0.7$ .

Now, plot slices through the volume of the sample at: X=6, X=9, Y=2, and Z=0.

```
figure
slice(X,Y,Z,V,[6 9],2,0);
shading flat
```

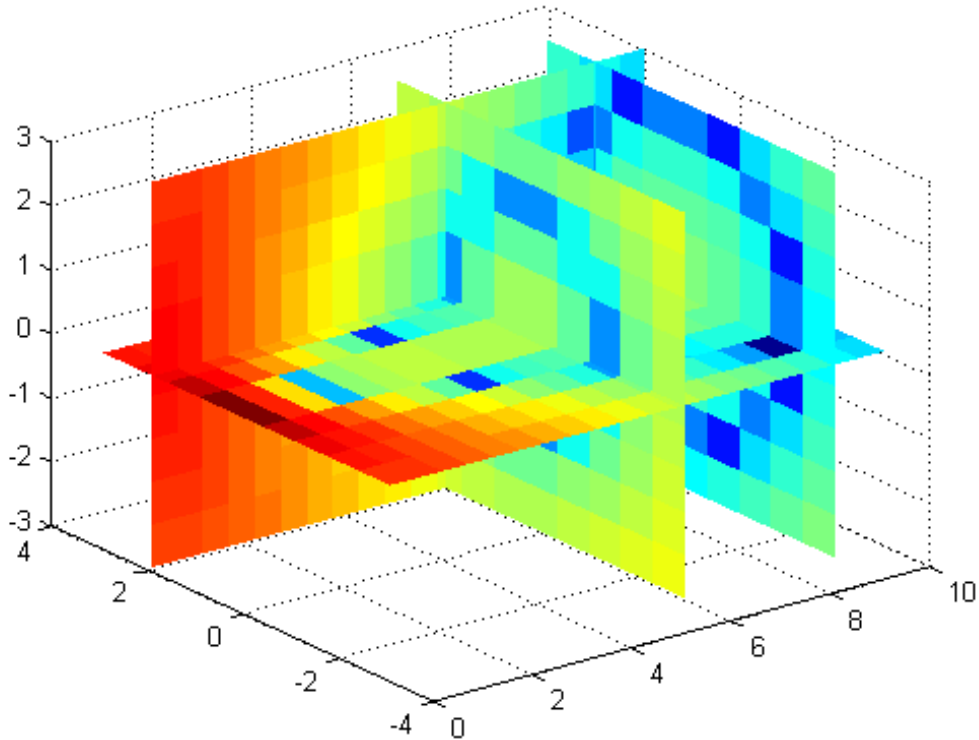



Create a query grid with spacing of 0.25.

```
[Xq,Yq,Zq] = meshgrid(.1:.25:10, -3:.25:3, -3:.25:3);
```

Interpolate at the points in the query grid and plot the results using the same slice planes.

```
Vq = interp3(X,Y,Z,V,Xq,Yq,Zq);
figure
slice(Xq,Yq,Zq,Vq,[6 9],2,0);
shading flat
```

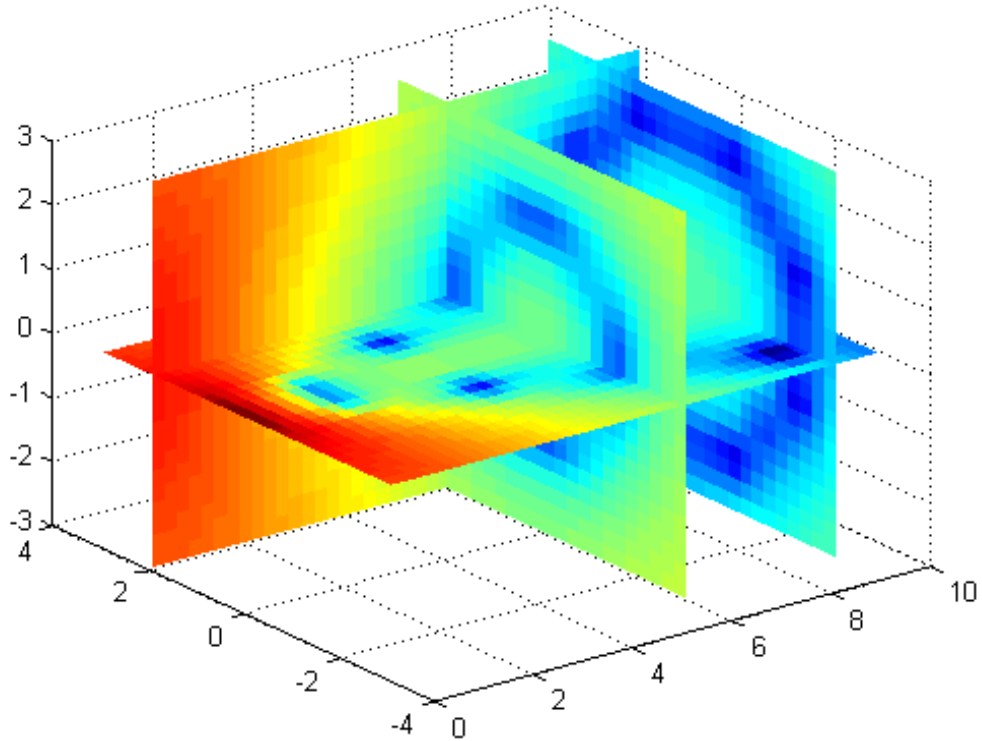

## Interpolate Using Cubic Method

Load the points and values of the flow function, sampled at 10 points in each dimension.

```
[X,Y,Z,V] = flow(10);
```

The flow function returns the grid in the arrays, X, Y, Z. The grid covers the region,  $0.1 \leq X \leq 10$ ,  $-3 \leq Y \leq 3$ ,  $-3 \leq Z \leq 3$ , and the spacing is  $\Delta X = 0.5$ ,  $\Delta Y = 0.7$ , and  $\Delta Z = 0.7$ .

Plot slices through the volume of the sample at:  $X=6$ ,  $X=9$ ,  $Y=2$ , and  $Z=0$ .

```
figure
slice(X,Y,Z,V,[6 9],2,0);
shading flat
```

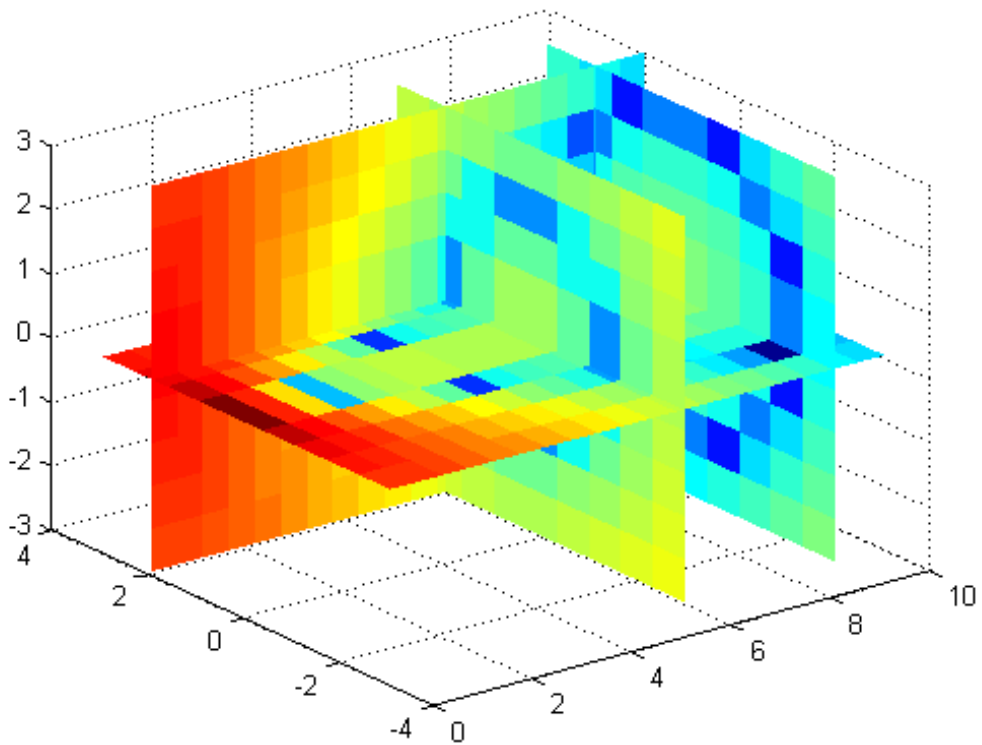

Create a query grid with spacing of 0.25.

```
[Xq,Yq,Zq] = meshgrid(.1:.25:10,-3:.25:3,-3:.25:3);
```

# interp3

---

Interpolate at the points in the query grid using the 'cubic' interpolation method. Then plot the results.

```
Vq = interp3(X,Y,Z,V,Xq,Yq,Zq,'cubic');
figure
slice(Xq,Yq,Zq,Vq,[6 9],2,0);
shading flat
```

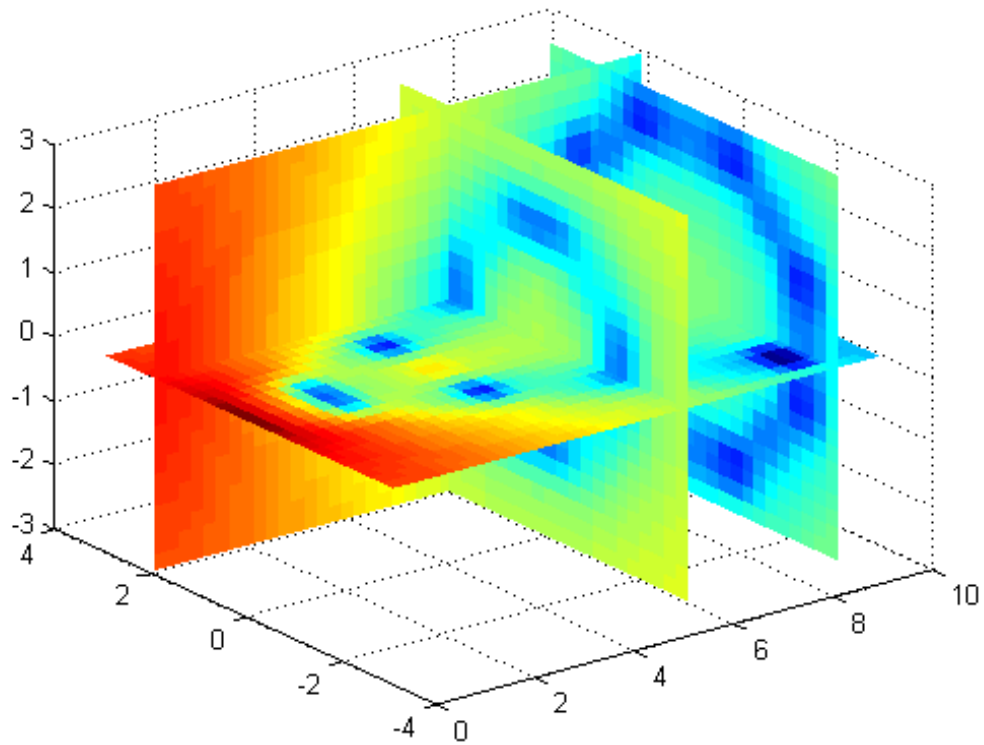

### Evaluate Outside the Domain of X, Y, and Z

Create the grid vectors,  $x$ ,  $y$ , and  $z$ . These vectors define the points associated with values in  $V$ .

```
x = 1:100;
y = (1:50)';
z = 1:30;
```

Define the sample values to be a 50-by-100-by-30 random number array,  $V$ . Use the `gallery` function to create the array.

```
V = gallery('uniformdata',50,100,30,0);
```

Evaluate  $V$  at three points outside the domain of  $x$ ,  $y$ , and  $z$ . Specify `extrapval = -1`.

```
xq = [0 0 0];
yq = [0 0 51];
zq = [0 101 102];
vq = interp3(x,y,z,V,xq,yq,zq,'linear',-1)
```

```
vq =
```

```
 -1 -1 -1
```

All three points evaluate to `-1` because they are outside the domain of  $x$ ,  $y$ , and  $z$ .

### See Also

[interp1](#) | [interp2](#) | [interpn](#) | [meshgrid](#)

# interpft

---

**Purpose** 1-D interpolation using FFT method

**Syntax**  
`y = interpft(x,n)`  
`y = interpft(x,n,dim)`

**Description** `y = interpft(x,n)` returns the vector `y` that contains the value of the periodic function `x` resampled to `n` equally spaced points.

If `length(x) = m`, and `x` has sample interval `dx`, then the new sample interval for `y` is `dy = dx*m/n`. Note that `n` cannot be smaller than `m`.

If `X` is a matrix, `interpft` operates on the columns of `X`, returning a matrix `Y` with the same number of columns as `X`, but with `n` rows.

`y = interpft(x,n,dim)` operates along the specified dimension.

**Algorithms** The `interpft` command uses the FFT method. The original vector `x` is transformed to the Fourier domain using `fft` and then transformed back with more points.

**Examples** Interpolate a triangle-like signal using an interpolation factor of 5. First, set up signal to be interpolated:

```
y = [0 .5 1 1.5 2 1.5 1 .5 0 -.5 -1 -1.5 -2 -1.5 -1 -.5 0];
N = length(y);
```

Perform the interpolation:

```
L = 5;
M = N*L;
x = 0:L:L*N-1;
xi = 0:M-1;
yi = interpft(y,M);
plot(x,y,'o',xi,yi,'*')
legend('Original data','Interpolated data')
```

**See Also** `interp1`

## Purpose

Interpolation for 1-D, 2-D, 3-D, and N-D gridded data in ndgrid format

In a future release, `interpn` will not accept mixed combinations of row and column vectors for the sample and query grids. For more information, and recommendations for updating your code, see “Functionality being removed or changed”.

## Syntax

```
Vq = interpn(X1,X2,...,Xn,V,Xq1,Xq2,...,Xqn)
```

```
Vq = interpn(V,Xq1,Xq2,...,Xqn)
```

```
Vq = interpn(V)
```

```
Vq = interpn(V,k)
```

```
Vq = interpn(__ ,method)
```

```
Vq = interpn(__ ,method,extrapval)
```

## Description

`Vq = interpn(X1,X2,...,Xn,V,Xq1,Xq2,...,Xqn)` returns interpolated values of a function of  $n$  variables at specific query points using linear interpolation. The results always pass through the original sampling of the function.  $X_1, X_2, \dots, X_n$  contain the coordinates of the sample points.  $V$  contains the corresponding function values at each sample point.  $X_{q1}, X_{q2}, \dots, X_{qn}$  contain the coordinates of the query points.

`Vq = interpn(V,Xq1,Xq2,...,Xqn)` assumes a default grid of sample points. The default grid consists of the points,  $1, 2, 3, \dots, n_i$  in each dimension. The value of  $n_i$  is the length of the  $i$ th dimension in  $V$ . Use this syntax to when you want to conserve memory and are not concerned about the absolute distances between points.

`Vq = interpn(V)` returns the interpolated values on a refined grid formed by dividing the interval between sample values once in each dimension.

`Vq = interpn(V,k)` returns the interpolated values on a refined grid formed by repeatedly dividing the intervals  $k$  times in each dimension.

`Vq = interpn( ___, method)` specifies an optional, trailing input argument that you can pass with any of the previous syntaxes. The `method` argument can be any of the following strings that specify alternative interpolation methods: `'linear'`, `'nearest'`, `'pchip'`, `'cubic'`, or `'spline'`. The default method is `'linear'`.

`Vq = interpn( ___, method, extrapval)` also specifies `extrapval`, a scalar value that is assigned to all queries that lie outside the domain of the sample points. If you omit the `extrapval` argument, then `interp` returns NaN values for queries outside the domain of the sample points.

## Input Arguments

### **X1,X2,...,Xn - Sample grid points**

arrays | vectors

Sample grid points, specified as real arrays or vectors.

- If `X1,X2,...,Xn` are arrays, then they contain the coordinates of a full grid (in `ndgrid` format). Use the `ndgrid` function to create the `X1,X2,...,Xn` arrays together. These arrays must be the same size.
- If `X1,X2,...,Xn` are vectors, then they are treated as grid vectors. The values in these vectors must be strictly monotonic and increasing.

**Example:** `[X1,X2,X3] = ndgrid(1:30,-10:10,1:5)`

### **Data Types**

single | double

### **V - Sample values**

array

Sample values, specified as a real or complex array. The size requirements for `V` depend on the size of `X1,X2,...,Xn`.

- If `X1,X2,...,Xn` are arrays representing a full grid (in `ndgrid` format), then the size of `V` matches the size of any array, `X1,X2,...,Xn`.
- If `X1,X2,...,Xn` are grid vectors, then `V` is an array whose `i`th dimension is the same length as grid vector `Xi`, where `i = 1,2,...,n`.



**Example:** `rand(10,5,3,2)`

## Data Types

`single` | `double`

**Complex Number Support:** Yes

## Xq1,Xq2,...,Xqn - Query points

`scalars` | `vectors` | `arrays`

Query points, specified as a real scalars, vectors, or arrays.

- If  $X_{q1}, X_{q2}, \dots, X_{qn}$  are scalars, then they are the coordinates of a single query point in  $R^n$ .
- If  $X_{q1}, X_{q2}, \dots, X_{qn}$  are vectors of different orientations, then  $X_{q1}, X_{q2}, \dots, X_{qn}$  are treated as grid vectors in  $R^n$ .
- If  $X_{q1}, X_{q2}, \dots, X_{qn}$  are vectors of the same size and orientation, then  $X_{q1}, X_{q2}, \dots, X_{qn}$  are treated as scattered points in  $R^n$ .
- If  $X_{q1}, X_{q2}, \dots, X_{qn}$  are arrays of the same size, then they represent either a full grid of query points (in `ndgrid` format) or scattered points in  $R^n$ .

**Example:** `[X1,X2,X3,X4] = ndgrid(1:10,1:5,7:9,10:11)`

## Data Types

`single` | `double`

## k - Refinement factor

1 (default) | real, nonnegative, integer scalar

Refinement factor, specified as a real, nonnegative, integer scalar. This value specifies the number of times to repeatedly divide the intervals of the refined grid in each dimension. This results in  $2^k - 1$  interpolated points between sample values.

If  $k$  is 0, then  $V_q$  is the same as  $V$ .

`interp(V, 1)` is the same as `interp(V)`.

The following illustration depicts  $k=2$  in  $R^2$ . There are 72 interpolated values in red and 9 sample values in black.

# interp

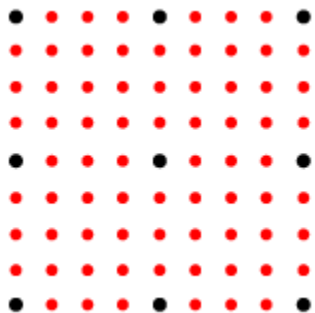

Example: `interp(V,2)`

## Data Types

single | double

## method - Interpolation method

'linear' (default) | 'nearest' | 'pchip' | 'cubic' | 'spline'

Interpolation method, specified as a string from this table.

| Method    | Description                                                                                                                                                                               | Continuity    | Comments                                                                                                                                            |
|-----------|-------------------------------------------------------------------------------------------------------------------------------------------------------------------------------------------|---------------|-----------------------------------------------------------------------------------------------------------------------------------------------------|
| 'linear'  | The interpolated value at a query point is based on linear interpolation of the values at neighboring grid points in each respective dimension. This is the default interpolation method. | $C^0$         | <ul style="list-style-type: none"><li>• Requires at least two grid points in each dimension</li><li>• Requires more memory than 'nearest'</li></ul> |
| 'nearest' | The interpolated value at a query point is the value                                                                                                                                      | Discontinuous | <ul style="list-style-type: none"><li>• Requires two grid points in each dimension.</li></ul>                                                       |

(Continued)

| Method  | Description                                                                                                                                                                                                   | Continuity | Comments                                                                                                                                                                                                                         |
|---------|---------------------------------------------------------------------------------------------------------------------------------------------------------------------------------------------------------------|------------|----------------------------------------------------------------------------------------------------------------------------------------------------------------------------------------------------------------------------------|
|         | at the nearest sample grid point.                                                                                                                                                                             |            | <ul style="list-style-type: none"> <li>• Fastest computation with modest memory requirements</li> </ul>                                                                                                                          |
| 'pchip' | Shape-preserving piecewise cubic interpolation (for 1-D only). The interpolated value at a query point is based on a shape-preserving piecewise cubic interpolation of the values at neighboring grid points. | $C^1$      | <ul style="list-style-type: none"> <li>• Requires at least four points</li> <li>• Requires more memory and computation time than 'linear'</li> </ul>                                                                             |
| 'cubic' | The interpolated value at a query point is based on a cubic interpolation of the values at neighboring grid points in each respective dimension. The interpolation is based on a cubic convolution.           | $C^1$      | <ul style="list-style-type: none"> <li>• Grid must have uniform spacing in each dimension, but the spacing does not have to be the same for all dimensions</li> <li>• Requires at least four points in each dimension</li> </ul> |

# interp

(Continued)

| Method   | Description                                                                                                                                                                                                                    | Continuity | Comments                                                                                                                                              |
|----------|--------------------------------------------------------------------------------------------------------------------------------------------------------------------------------------------------------------------------------|------------|-------------------------------------------------------------------------------------------------------------------------------------------------------|
|          |                                                                                                                                                                                                                                |            | <ul style="list-style-type: none"><li>Requires more memory and computation time than 'linear'</li></ul>                                               |
| 'spline' | The interpolated value at a query point is based on a cubic interpolation of the values at neighboring grid points in each respective dimension. The interpolation is based on a cubic spline using not-a-knot end conditions. | $C^2$      | <ul style="list-style-type: none"><li>Requires four points in each dimension</li><li>Requires more memory and computation time than 'cubic'</li></ul> |

**extrapval - Function value outside domain of  $X_1, X_2, \dots, X_n$**   
scalar

Function value outside domain of  $X_1, X_2, \dots, X_n$ , specified as a real or complex scalar. `interp` returns this constant value for all points outside the domain of  $X_1, X_2, \dots, X_n$ .

**Example:** 5

**Example:** 5+1i

**Data Types**

single | double

**Complex Number Support:** Yes

## Output Arguments

**Vq - Interpolated values**

scalar | vector | array

Interpolated values, returned as a real or complex scalar, vector, or array. The size and shape of `Vq` depends on the syntax you use and, in some cases, the size and value of the input arguments.

| Syntaxes                                                                                                                                                                                   | Special Conditions                                             | Size of Vq                                               | Example                                                                                                                                                            |
|--------------------------------------------------------------------------------------------------------------------------------------------------------------------------------------------|----------------------------------------------------------------|----------------------------------------------------------|--------------------------------------------------------------------------------------------------------------------------------------------------------------------|
| <code>interp(X1, ..., Xn, V, Xq1, ..., Xqn)</code><br><code>interp(V, Xq1, ..., Xqn)</code><br>and variations of these syntaxes that include <code>method</code> or <code>extrapval</code> | $Xq1, \dots, Xqn$ are scalars                                  | Scalar                                                   | <code>size(Vq) = [1 1]</code> when you pass $Xq1, \dots, Xqn$ as scalars.                                                                                          |
| Same as above                                                                                                                                                                              | $Xq1, \dots, Xqn$ are vectors of the same size and orientation | Vector of same size and orientation as $Xq1, \dots, Xqn$ | In 3-D, if <code>size(Xq1) = [100 1]</code> , and <code>size(Xq2) = [100 1]</code> , and <code>size(Xq3) = [100 1]</code> , then <code>size(Vq) = [100 1]</code> . |
| Same as above                                                                                                                                                                              | $Xq1, \dots, Xqn$ are vectors of mixed orientation             | <code>size(Vq) = [length(Xq1), ..., length(Xqn)]</code>  | In 3-D, if <code>size(Xq1) = [1 100]</code> , and <code>size(Xq2) = [50 1]</code> , and <code>size(Xq3) = [1 5]</code> , then <code>size(Vq) = [100 50 5]</code> . |
| Same as above                                                                                                                                                                              | $Xq1, \dots, Xqn$ are arrays of the same size                  | Array of the same size as $Xq1, \dots, Xqn$              | In 3-D, if <code>size(Xq1) = [50 25]</code> , and <code>size(Xq2) = [50 25]</code> , and <code>size(Xq3) = [50 25]</code> , then <code>size(Vq) = [50 25]</code> . |
| <code>interp(V, k)</code><br>and variations of this                                                                                                                                        | None                                                           | Array in which the length of the <i>i</i> th             | In 3-D, if <code>size(V) = [10 12 5]</code> ,                                                                                                                      |

# interp<sub>n</sub>

| Syntaxes                               | Special Conditions | Size of V <sub>q</sub>                            | Example                                                      |
|----------------------------------------|--------------------|---------------------------------------------------|--------------------------------------------------------------|
| syntax that include method or extrapol |                    | dimension is $2^k * (\text{size}(V,i) - 1) + 1$ , | and $k = 3$ ,<br>then $\text{size}(Vq) = [73$<br>$89\ 33]$ . |

## Definitions **Strictly Monotonic**

A set of values that are always increasing or decreasing, without reversals. For example, the sequence,  $a = [2\ 4\ 6\ 8]$  is strictly monotonic and increasing. The sequence,  $b = [2\ 4\ 4\ 6\ 8]$  is not strictly monotonic because there is no change in value between  $b(2)$  and  $b(3)$ . The sequence,  $c = [2\ 4\ 6\ 8\ 6]$  contains a reversal between  $c(4)$  and  $c(5)$ , so it is not monotonic at all.

## Full Grid (in ndgrid Format)

For `interpn`, the full grid consists of  $n$  arrays,  $X_1, X_2, \dots, X_n$ , whose elements represent a grid of points in  $R^n$ . The  $i$ th array,  $X_i$ , contains strictly monotonic, increasing values that vary most rapidly along the  $i$ th dimension.

Use the `ndgrid` function to create a full grid that you can pass to `interpn`. For example, the following code creates a full grid in  $R^2$  for the region,  $1 \leq X_1 \leq 3, 1 \leq X_2 \leq 4$ .

```
[X1,X2] = ndgrid(-1:3, (1:4))
```

X1 =

```
-1 -1 -1 -1
 0 0 0 0
 1 1 1 1
 2 2 2 2
 3 3 3 3
```

X2 =

```

1 2 3 4
1 2 3 4
1 2 3 4
1 2 3 4
1 2 3 4

```

## Grid Vectors

For `interp`, grid vectors consist of  $n$  vectors of mixed-orientation that define the points of a grid in  $R^n$ .

For example, the following code creates the grid vectors in  $R^3$  for the region,  $1 \leq x_1 \leq 3$ ,  $4 \leq x_2 \leq 5$ , and  $6 \leq x_3 \leq 8$ :

```

x1 = 1:3;
x2 = (4:5)';
x3 = 6:8;

```

## Scattered Points

For `interp`, scattered points consist of  $n$  arrays or vectors,  $Xq_1, Xq_2, \dots, Xq_n$ , that define a collection of points scattered in  $R^n$ . The  $i$ th array,  $X_i$ , contains the coordinates in the  $i$ th dimension.

For example, the following code specifies the points, (1, 19, 10), (6, 40, 1), (15, 33, 22), and (0, 61, 13) in  $R^3$ .

```

Xq1 = [1 6; 15 0];
Xq2 = [19 40; 33 61];
Xq3 = [10 1; 22 13];

```

## Examples

### 1-D Interpolation

Define the sample points and values.

```

x = [1 2 3 4 5];
v = [12 16 31 10 6];

```

Define the query points, `xq`, and interpolate.

# interp

```
xq = (1:0.1:5);
vq = interp(x,v,xq,'cubic');
```

Plot the result.

```
figure
plot(x,v,'o',xq,vq,'-');
legend('Samples','Cubic Interpolation');
```

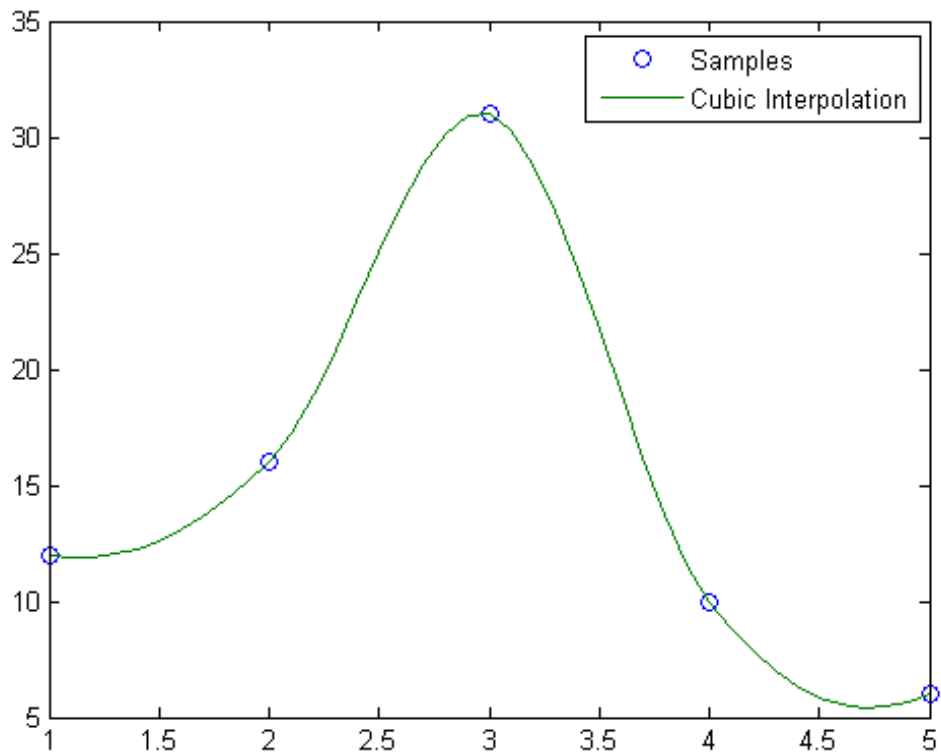



## 2-D Interpolation

Create a set of grid points and corresponding sample values.

```
[X1,X2] = ndgrid((-5:1:5));
R = sqrt(X1.^2 + X2.^2)+ eps;
V = sin(R)./(R);
```

Interpolate over a finer grid using `ntimes=1`.

```
Vq = interpn(V,'cubic');
mesh(Vq);
```

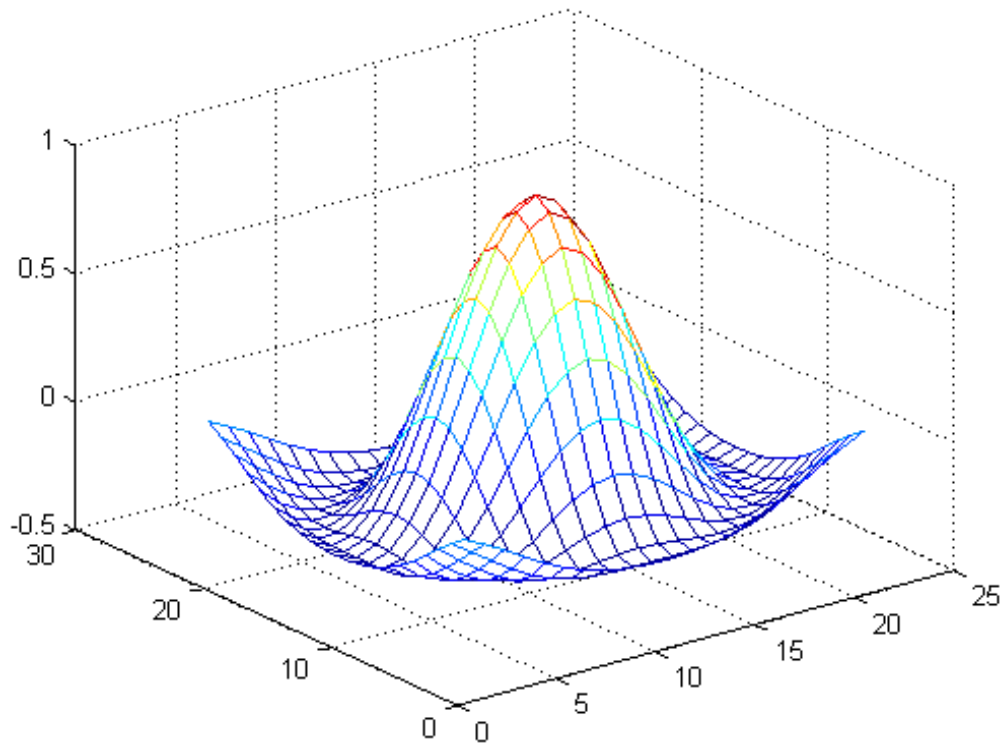

## Evaluate Outside Domain of 3-D Function

Create the grid vectors,  $x_1$ ,  $x_2$ , and  $x_3$ . These vectors define the points associated with the values in  $V$ .

```
x1 = 1:100;
x2 = (1:50)';
x3 = 1:30;
```

Define the sample values to be a 100-by-50-by-30 random number array, *V*. Use the `gallery` function to create the array.

```
V = gallery('uniformdata',100,50,30,0);
```

Evaluate *V* at three points outside the domain of *x1*, *x2*, and *x3*. Specify `extrapval = -1`.

```
xq1 = [0 0 0];
xq2 = [0 0 51];
xq3 = [0 101 102];
vq = interpn(x1,x2,x3,V,xq1,xq2,xq3,'linear',-1)
```

```
vq =
```

```
 -1 -1 -1
```

All three points evaluate to -1 because they are outside the domain of *x1*, *x2*, and *x3*.

## 4-D Interpolation

Define an anonymous function that represents  $f = te^{-x^2-y^2-z^2}$ .

```
f = @(x,y,z,t) t.*exp(-x.^2 - y.^2 - z.^2);
```

Create a grid of points in  $R^4$ . Then, pass the points through the function to create the sample values, *V*.

```
[x,y,z,t] = ndgrid(-1:0.2:1,-1:0.2:1,-1:0.2:1,0:2:10);
V = f(x,y,z,t);
```

Now, create the query grid.

```
[xq,yq,zq,tq] = ...
ndgrid(-1:0.05:1,-1:0.08:1,-1:0.05:1,0:0.5:10);
```

# interp

---

Interpolate V at the query points.

```
Vq = interpn(x,y,z,t,V,xq,yq,zq,tq);
```

Create a movie to show the results.

```
figure('renderer','zbuffer');
nframes = size(tq, 4);
for j = 1:nframes
 slice(yq(:,:,j),xq(:,:,j),zq(:,:,j),...
 Vq(:,:,j),0,0,0);
 caxis([0 10]);
 M(j) = getframe;
end
movie(M);
```

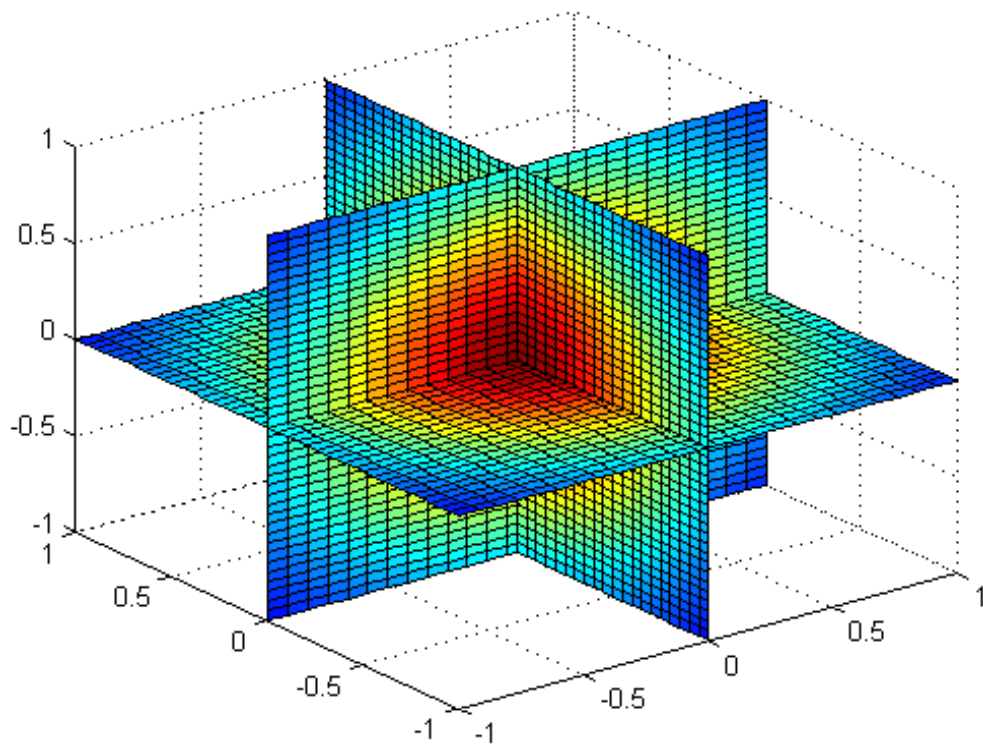

## See Also

[interp1](#) | [interp2](#) | [interp3](#) | [ndgrid](#)

# interpstreamspeed

---

**Purpose** Interpolate stream-line vertices from flow speed

**Syntax**

```
interpstreamspeed(X,Y,Z,U,V,W,vertices)
interpstreamspeed(U,V,W,vertices)
interpstreamspeed(X,Y,Z,speed,vertices)
interpstreamspeed(speed,vertices)
interpstreamspeed(X,Y,U,V,vertices)
interpstreamspeed(U,V,vertices)
interpstreamspeed(X,Y,speed,vertices)
interpstreamspeed(speed,vertices)
interpstreamspeed(...,sf)
vertsout = interpstreamspeed(...)
```

**Description** `interpstreamspeed(X,Y,Z,U,V,W,vertices)` interpolates streamline vertices based on the magnitude of the vector data `U, V, W`.

The arrays `X, Y, and Z`, which define the coordinates for `U, V, and W`, must be monotonic, but do not need to be uniformly spaced. `X, Y, and Z` must have the same number of elements, as if produced by `meshgrid`.

`interpstreamspeed(U,V,W,vertices)` assumes `X, Y, and Z` are determined by the expression

```
[X Y Z] = meshgrid(1:n,1:m,1:p)
```

where `[m n p] = size(U)`.

`interpstreamspeed(X,Y,Z,speed,vertices)` uses the 3-D array `speed` for the speed of the vector field.

`interpstreamspeed(speed,vertices)` assumes `X, Y, and Z` are determined by the expression

```
[X Y Z] = meshgrid(1:n,1:m,1:p)
```

where `[m n p]=size(speed)`.

`interpstreamspeed(X,Y,U,V,vertices)` interpolates streamline vertices based on the magnitude of the vector data `U, V`.

The arrays `X` and `Y`, which define the coordinates for `U` and `V`, must be monotonic, but do not need to be uniformly spaced. `X` and `Y` must have the same number of elements, as if produced by `meshgrid`.

`interpstreamspeed(U,V,vertices)` assumes `X` and `Y` are determined by the expression

```
[X Y] = meshgrid(1:n,1:m)
```

where `[M N]=size(U)`.

`interpstreamspeed(X,Y,speed,vertices)` uses the 2-D array `speed` for the speed of the vector field.

`interpstreamspeed(speed,vertices)` assumes `X` and `Y` are determined by the expression

```
[X Y] = meshgrid(1:n,1:m)
```

where `[M,N]= size(speed)`.

`interpstreamspeed(...,sf)` uses `sf` to scale the magnitude of the vector data and therefore controls the number of interpolated vertices. For example, if `sf` is 3, then `interpstreamspeed` creates only one-third of the vertices.

`vertsout = interpstreamspeed(...)` returns a cell array of vertex arrays.

## Examples

This example draws streamlines using the vertices returned by `interpstreamspeed`. Dot markers indicate the location of each vertex. This example enables you to visualize the relative speeds of the flow data. Streamlines having widely spaced vertices indicate faster flow; those with closely spaced vertices indicate slower flow.

```
load wind
[sx sy sz] = meshgrid(80,20:1:55,5);
verts = stream3(x,y,z,u,v,w,sx,sy,sz);
iverts = interpstreamspeed(x,y,z,u,v,w,verts,.2);
sl = streamline(iverts);
```

# interpstreamspeed

---

```
set(sl,'Marker','.')
axis tight; view(2); daspect([1 1 1])
```

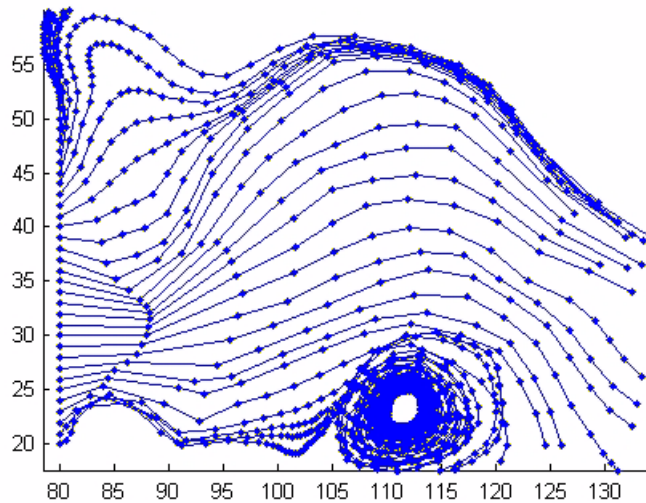

This example plots streamlines whose vertex spacing indicates the value of the gradient along the streamline.

```
figure
z = membrane(6,30);
[u v] = gradient(z);
pcolor(z)
hold on
[verts averts] = streamslice(u,v);
iverts = interpstreamspeed(u,v,verts,15);
sl = streamline(iverts);
set(sl,'Marker','.')
shading interp
axis tight
view(2)
```



```
daspect([1,1,1])
hold off
```

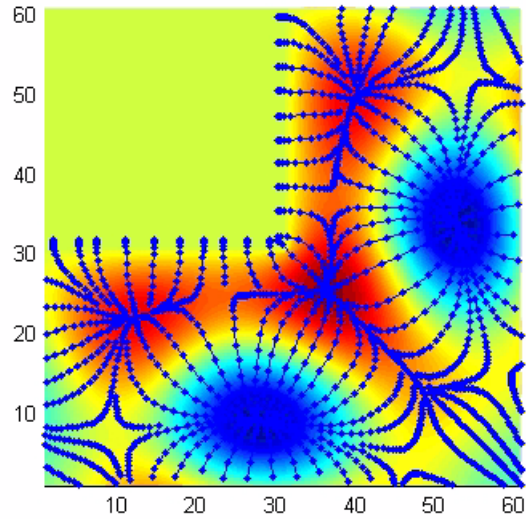

## See Also

[stream2](#) | [stream3](#) | [streamline](#) | [streamslice](#) | [streamparticles](#)

# intersect

---

## Purpose

Set intersection of two arrays

## Syntax

```
C = intersect(A,B)
C = intersect(A,B,'rows')
[C,ia,ib] = intersect(A,B)
[C,ia,ib] = intersect(A,B,'rows')

[C,ia,ib] = intersect(__,setOrder)

[C,ia,ib] = intersect(A,B,'legacy')

[C,ia,ib] = intersect(A,B,'rows','legacy')
```

## Description

`C = intersect(A,B)` returns the data common to both A and B with no repetitions.

- If A and B are numeric arrays, logical arrays, character arrays, categorical arrays, or cell arrays of strings, then `intersect` returns the values common to both A and B. The values of C are in sorted order.
- If A and B are tables, then `intersect` returns the set of rows common to both tables. The rows of table C are in sorted order.

`C = intersect(A,B,'rows')` treats each row of A and each row of B as single entities and returns the rows common to both A and B. The rows of C are in sorted order.

The 'rows' option does not support cell arrays.

`[C,ia,ib] = intersect(A,B)` also returns index vectors `ia` and `ib`.

- If A and B are numeric arrays, logical arrays, character arrays, categorical arrays, or cell arrays of strings, then `C = A(ia)` and `C = B(ib)`.
- If A and B are tables, then `C = A(ia,:)` and `C = B(ib,:)`.

`[C,ia,ib] = intersect(A,B,'rows')` also returns index vectors `ia` and `ib`, such that `C = A(ia,:)` and `C = B(ib,:)`.

`[C,ia,ib] = intersect(___,setOrder)` returns `C` in a specific order using any of the input arguments in the previous syntaxes. `setOrder='sorted'` returns the values (or rows) of `C` in sorted order. `setOrder='stable'` returns the values (or rows) of `C` in the same order as `A`, and then `B`. If no value is specified, the default is `'sorted'`.

`[C,ia,ib] = intersect(A,B,'legacy')` and `[C,ia,ib] = intersect(A,B,'rows','legacy')` preserve the behavior of the `intersect` function from R2012b and prior releases.

The `'legacy'` option does not support categorical arrays or tables.

## Input Arguments

### **A,B - Input arrays**

numeric arrays | logical arrays | character arrays | categorical arrays  
| cell arrays of strings | tables

Input arrays, specified as numeric arrays, logical arrays, character arrays, categorical arrays, cell arrays of strings, or tables.

`A` and `B` must be of the same class with the following exceptions:

- `logical`, `char`, and all numeric classes can combine with double arrays.
- Cell arrays of strings can combine with `char` arrays.
- Categorical arrays can combine with cell arrays of strings or single strings.

If `A` and `B` are both ordinal categorical arrays, they must have the same sets of categories, including their order. If neither `A` nor `B` are ordinal, they need not have the same sets of categories, and the comparison is performed using the category names. In this case, the categories of `C` are the sorted union of the categories from `A` and `B`.

If you specify the `'rows'` option, `A` and `B` must have the same number of columns.

# intersect

If A and B are tables, they must have the same variable names. Conversely, the row names do not matter. Two rows that have the same values, but different names, are considered equal.

Furthermore, A and B can be objects with the following class methods:

- sort (or sortrows for the 'rows' option)
- ne

The object class methods must be consistent with each other. These objects include heterogeneous arrays derived from the same root class.

## setOrder - Order flag

'sorted' (default) | 'stable'

Order flag, specified as 'sorted' or 'stable', indicates the order of the values (or rows) in C.

| Order Flag | Meaning                                                                                                                                                                                |
|------------|----------------------------------------------------------------------------------------------------------------------------------------------------------------------------------------|
| 'sorted'   | The values (or rows) in C return in sorted order. For example:<br><code>C = intersect([7 0 5],[7 1 5],'sorted')</code> returns<br><code>C = [5 7]</code> .                             |
| 'stable'   | The values (or rows) in C return in the same order as they appear in A and B. For example:<br><code>C = intersect([7 0 5],[7 1 5],'stable')</code> returns<br><code>C = [7 5]</code> . |

## Output Arguments

### C - Data common to A and B

vector | matrix | table

Data common to A and B, returned as a vector, matrix, or table. If the inputs A and B are tables, the order of the variables in the resulting table, C, is the same as the order of the variables in A.

The following describes the shape of **C** when the inputs are vectors or matrices and when the 'legacy' flag is not specified:

- If the 'rows' flag is not specified, then **C** is a column vector unless both **A** and **B** are row vectors.
- If the 'rows' flag is not specified and both **A** and **B** are row vectors, then **C** is a row vector.
- If the 'rows' flag is specified, then **C** is a matrix containing the rows in common from **A** and **B**.
- If **A** and **B** have no values (or rows) in common, then **C** is an empty matrix.

The class of the inputs **A** and **B** determines the class of **C**:

- If the class of **A** and **B** are the same, then **C** is the same class.
- If you combine a `char` or nondouble numeric class with `double`, then **C** is the same class as the nondouble input.
- If you combine a `logical` class with `double`, then **C** is `double`.
- If you combine a cell array of strings with `char`, then **C** is a cell array of strings.
- If you combine a categorical array with a cell array of strings or single string, then **C** is a categorical array.

### **ia - Index to A**

column vector

Index to **A**, returned as a column vector when the 'legacy' flag is not specified. **ia** identifies the values (or rows) in **A** that are common to **B**. If there is a repeated value (or row) in **A**, then **ia** contains the index to the first occurrence of the value (or row).

### **ib - Index to B**

column vector

Index to **B**, returned as a column vector when the 'legacy' flag is not specified. **ib** identifies the values (or rows) in **B** that are common to **A**. If

# intersect

---

there is a repeated value (or row) in B, then `ib` contains the index to the first occurrence of the value (or row).

## Examples

### Intersection of Two Vectors

Define two vectors with values in common.

```
A = [7 1 7 7 4]; B = [7 0 4 4 0];
```

Find the values common to both A and B.

```
C = intersect(A,B)
```

```
C =
```

```
 4 7
```

### Intersection of Two Tables

Define two tables with rows in common.

```
A = table([1:5]', ['A'; 'B'; 'C'; 'D'; 'E'], logical([0;1;0;1;0]))
B = table([1:2:10]', ['A'; 'C'; 'E'; 'G'; 'I'], logical(zeros(5,1)))
```

```
A =
```

| Var1 | Var2 | Var3  |
|------|------|-------|
| 1    | A    | false |
| 2    | B    | true  |
| 3    | C    | false |
| 4    | D    | true  |
| 5    | E    | false |

```
B =
```

| Var1 | Var2 | Var3  |
|------|------|-------|
| 1    | A    | false |
| 3    | C    | false |
| 5    | E    | false |
| 7    | G    | false |
| 9    | I    | false |

```

1 A false
3 C false
5 E false
7 G false
9 I false

```

Find the rows common to both A and B.

```
C = intersect(A,B)
```

```
C =
```

```

Var1 Var2 Var3
---- ---- -----
1 A false
3 C false
5 E false

```

### Intersection of Two Vectors and Their Indices

Define two vectors with values in common.

```
A = [7 1 7 7 4]; B = [7 0 4 4 0];
```

Find the values common to both A and B, as well as the index vectors *ia* and *ib*, such that  $C = A(ia)$  and  $C = B(ib)$ .

```
[C,ia,ib] = intersect(A,B)
```

```
C =
```

```

4 7

```

```
ia =
```

```

5
1

```

# intersect

---

```
ib =
```

```
 3
 1
```

## Intersection of Two Tables and Their Indices

Define a table, A, of gender, age, and height for five people.

```
A = table(['M';'M';'F';'M';'F'],[27;52;31;46;35],[74;68;64;61;64],...
'VariableNames',{'Gender' 'Age' 'Height'},...
'RowNames',{'Ted' 'Fred' 'Betty' 'Bob' 'Judy'})
```

```
A =
```

|       | Gender | Age | Height |
|-------|--------|-----|--------|
|       | -----  | --- | -----  |
| Ted   | M      | 27  | 74     |
| Fred  | M      | 52  | 68     |
| Betty | F      | 31  | 64     |
| Bob   | M      | 46  | 61     |
| Judy  | F      | 35  | 64     |

Define a table, B, with rows in common with A.

```
B = table(['F';'M';'F';'F'],[31;47;35;23],[64;68;62;58],...
'VariableNames',{'Gender' 'Age' 'Height'},...
'RowNames',{'Meg' 'Joe' 'Beth' 'Amy'})
```

```
B =
```

|      | Gender | Age | Height |
|------|--------|-----|--------|
|      | -----  | --- | -----  |
| Meg  | F      | 31  | 64     |
| Joe  | M      | 47  | 68     |
| Beth | F      | 35  | 62     |
| Amy  | F      | 23  | 58     |



Find the rows common to both **A** and **B**, as well as the index vectors **ia** and **ib**, such that **C** = **A(ia,:)** and **C** = **B(ib,:)**.

```
[C,ia,ib] = intersect(A,B)
```

```
C =
```

|       | Gender | Age | Height |
|-------|--------|-----|--------|
|       | -----  | --- | -----  |
| Betty | F      | 31  | 64     |

```
ia =
```

```
3
```

```
ib =
```

```
1
```

Two rows that have the same values, but different names, are considered equal. Therefore, we discover that Betty, **A(3,:)**, and Meg, **B(1,:)** have the same gender, age, and height.

## Intersection of Rows in Two Matrices

Define two matrices with rows in common.

```
A = [2 2 2; 0 0 1; 1 2 3; 1 1 1];
```

```
B = [1 2 3; 2 2 2; 2 2 0];
```

Find the rows common to both **A** and **B** as well as the index vectors **ia** and **ib**, such that **C** = **A(ia,:)** and **C** = **B(ib,:)**.

```
[C,ia,ib] = intersect(A,B,'rows')
```

```
C =
```

# intersect

---

```
 1 2 3
 2 2 2
```

```
ia =
```

```
 3
 1
```

```
ib =
```

```
 1
 2
```

A and B do not need to have the same number of rows, but they must have the same number of columns.

## Intersection with Specified Output Order

Use the `setOrder` argument to specify the ordering of the values in C.

Specify `'stable'` if you want the values in C to have the same order as in A.

```
A = [7 1 7 7 4]; B = [7 0 4 4 0];
[C,ia,ib] = intersect(A,B,'stable')
```

```
C =
```

```
 7 4
```

```
ia =
```

```
 1
 5
```

```
ib =
```

```
 1
 3
```

Alternatively, you can specify 'sorted' order.

```
[C,ia,ib] = intersect(A,B,'sorted')
```

```
C =
```

```
 4 7
```

```
ia =
```

```
 5
 1
```

```
ib =
```

```
 3
 1
```

## Intersection of Vectors Containing NaNs

Define two vectors containing NaN.

```
A = [5 NaN NaN]; B = [5 NaN NaN];
```

Find the values common to both A and B.

```
C = intersect(A,B)
```

```
C =
```

```
 5
```

# intersect

---

`intersect` treats NaN values as distinct.

## Cell Array of Strings with Trailing White Space

Create a cell array of strings, A.

```
A = {'dog', 'cat', 'fish', 'horse'};
```

Create a cell array of strings, B, where some of the strings have trailing white space.

```
B = {'dog ', 'cat', 'fish ', 'horse'};
```

Find the strings common to both A and B.

```
[C,ia,ib] = intersect(A,B)
```

```
C =
 'cat' 'horse'
```

```
ia =
```

```
 2
 4
```

```
ib =
```

```
 2
 4
```

`intersect` treats trailing white space in cell arrays of strings as distinct characters.

## Intersection of Arrays of Different Classes and Shapes

Create a column vector character array.

```
A = ['A';'B';'C'], class(A)
```

```
A =
```

```
A
B
C
```

```
ans =
```

```
char
```

Create a 2-by-3 matrix containing elements of numeric type double.

```
B = [65 66 67;68 69 70], class(B)
```

```
B =
```

```
 65 66 67
 68 69 70
```

```
ans =
```

```
double
```

Find the values common to both A and B.

```
[C,ia,ib] = intersect(A,B)
```

```
C =
```

```
A
```

# intersect

---

```
B
C
```

```
ia =
```

```
1
2
3
```

```
ib =
```

```
1
3
5
```

`intersect` interprets `B` as a character array and returns a character array, `C`.

```
class(C)
```

```
ans =
```

```
char
```

## **Intersection of Char and Cell Array of Strings**

Create a character array containing animal names that have three letters.

```
A = ['dog'; 'cat'; 'fox'; 'pig'];
class(A)
```

```
ans =
```

```
char
```

Create a cell array of strings containing animal names of varying lengths.

```
B = {'cat','dog','fish','horse'};
class(B)
```

```
ans =
```

```
cell
```

Find the strings common to both A and B.

```
C = intersect(A,B)
```

```
C =
```

```
 'cat'
 'dog'
```

The result, C, is a cell array of strings.

```
class(C)
```

```
ans =
```

```
cell
```

### **Preserve Legacy Behavior of intersect**

Use the 'legacy' flag to preserve the behavior of `intersect` from R2012b and prior releases in your code.

Find the intersection of A and B with the current behavior.

```
A = [7 1 7 7 4]; B = [7 0 4 4 0];
[C1,ia1,ib1] = intersect(A,B)
```

```
C1 =
```

# intersect

---

```
4 7
```

```
ia1 =
```

```
5
1
```

```
ib1 =
```

```
3
1
```

Find the unique elements of A and preserve the legacy behavior.

```
[C2,ia2,ib2] = intersect(A,B,'legacy')
```

```
C2 =
```

```
4 7
```

```
ia2 =
```

```
5 4
```

```
ib2 =
```

```
4 1
```

## Tips

- To find the intersection with respect to a subset of variables from a table, you can use column subscripting. For example, you can use `intersect(A(:,vars),B(:,vars))`, where *vars* is a positive integer,



a vector of positive integers, a variable name, a cell array of variable names, or a logical vector.

**See Also**

`unique` | `union` | `ismember` | `issorted` | `setdiff` | `setxor` | `sort`

**Concepts**

- “Combine Categorical Arrays”

# intmax

---

**Purpose** Largest value of specified integer type

**Syntax**  
`v = intmax`  
`v = intmax('classname')`

**Description** `v = intmax` is the largest positive value that can be represented in the MATLAB software with a 32-bit integer. Any value larger than the value returned by `intmax` saturates to the `intmax` value when cast to a 32-bit integer.

`v = intmax('classname')` is the largest positive value in the integer class `classname`. Valid values for the string `classname` are

|         |          |          |          |
|---------|----------|----------|----------|
| 'int8'  | 'int16'  | 'int32'  | 'int64'  |
| 'uint8' | 'uint16' | 'uint32' | 'uint64' |

`intmax('int32')` is the same as `intmax` with no arguments.

**Examples** Find the maximum value for a 64-bit signed integer:

```
v = intmax('int64')
v =
 9223372036854775807
```

Convert this value to a 32-bit signed integer:

```
x = int32(v)
x =
 2147483647
```

Compare the result with the default value returned by `intmax`:

```
isequal(x, intmax)
ans =
 1
```

**See Also** `intmin` | `realmax` | `realmin` | `int8` | `uint8` | `isa` | `class`

**Purpose** Smallest value of specified integer type

**Syntax**

```
v = intmin
v = intmin('classname')
```

**Description** `v = intmin` is the smallest value that can be represented in the MATLAB software with a 32-bit integer. Any value smaller than the value returned by `intmin` saturates to the `intmin` value when cast to a 32-bit integer.

`v = intmin('classname')` is the smallest positive value in the integer class `classname`. Valid values for the string `classname` are

|         |          |          |          |
|---------|----------|----------|----------|
| 'int8'  | 'int16'  | 'int32'  | 'int64'  |
| 'uint8' | 'uint16' | 'uint32' | 'uint64' |

`intmin('int32')` is the same as `intmin` with no arguments.

**Examples** Find the minimum value for a 64-bit signed integer:

```
v = intmin('int64')
v =
-9223372036854775808
```

Convert this value to a 32-bit signed integer:

```
x = int32(v)
x =
2147483647
```

Compare the result with the default value returned by `intmin`:

```
isequal(x, intmin)
ans =
1
```

**See Also** `intmax` | `realmin` | `realmax` | `int8` | `uint8` | `isa` | `class`

**Purpose** Matrix inverse

**Syntax**  $Y = \text{inv}(X)$

**Description**  $Y = \text{inv}(X)$  returns the inverse of the square matrix  $X$ . A warning message is printed if  $X$  is badly scaled or nearly singular.

In practice, it is seldom necessary to form the explicit inverse of a matrix. A frequent misuse of `inv` arises when solving the system of linear equations  $Ax = b$ . One way to solve this is with  $x = \text{inv}(A)*b$ . A better way, from both an execution time and numerical accuracy standpoint, is to use the matrix division operator  $x = A \setminus b$ . This produces the solution using Gaussian elimination, without forming the inverse. See `mldivide (\)` for further information.

---

**Note** MATLAB computes  $X^{(-1)}$  and  $\text{inv}(X)$  in the same manner, and both are subject to the same limitations.

---

## Examples

Here is an example demonstrating the difference between solving a linear system by inverting the matrix with  $\text{inv}(A)*b$  and solving it directly with  $A \setminus b$ . A random matrix  $A$  of order 500 is constructed so that its condition number, `cond(A)`, is  $1.e10$ , and its norm, `norm(A)`, is 1. The exact solution  $x$  is a random vector of length 500 and the right-hand side is  $b = A*x$ . Thus the system of linear equations is badly conditioned, but consistent.

On a 300 MHz, laptop computer the statements

```
n = 500;
Q = orth(randn(n,n));
d = logspace(0, -10, n);
A = Q*diag(d)*Q';
x = randn(n,1);
b = A*x;
tic, y = inv(A)*b; toc
err = norm(y-x)
```

```
res = norm(A*y-b)
```

```
produce
```

```
elapsed_time =
```

```
 1.4320
```

```
err =
```

```
 7.3260e-006
```

```
res =
```

```
 4.7511e-007
```

```
while the statements
```

```
tic, z = A\b, toc
```

```
err = norm(z-x)
```

```
res = norm(A*z-b)
```

```
produce
```

```
elapsed_time =
```

```
 0.6410
```

```
err =
```

```
 7.1209e-006
```

```
res =
```

```
 4.4509e-015
```

It takes almost two and one half times as long to compute the solution with  $y = \text{inv}(A)*b$  as with  $z = A\b$ . Both produce computed solutions with about the same error,  $1.e-6$ , reflecting the condition number of the matrix. But the size of the residuals, obtained by plugging the computed solution back into the original equations, differs by several orders of magnitude. The direct solution produces residuals on the order of the machine accuracy, even though the system is badly conditioned.

The behavior of this example is typical. Using  $A\b$  instead of  $\text{inv}(A)*b$  is two to three times as fast and produces residuals on the order of machine accuracy, relative to the magnitude of the data.

## See Also

`det` | `lu` | `rref` | `mldivide`

# invhilb

---

**Purpose** Inverse of Hilbert matrix

**Syntax** `H = invhilb(n)`

**Description** `H = invhilb(n)` generates the exact inverse of the exact Hilbert matrix for  $n$  less than about 15. For larger  $n$ , `invhilb(n)` generates an approximation to the inverse Hilbert matrix.

**Limitations** The exact inverse of the exact Hilbert matrix is a matrix whose elements are large integers. These integers may be represented as floating-point numbers without roundoff error as long as the order of the matrix,  $n$ , is less than 15.

Comparing `invhilb(n)` with `inv(hilb(n))` involves the effects of two or three sets of roundoff errors:

- The errors caused by representing `hilb(n)`
- The errors in the matrix inversion process
- The errors, if any, in representing `invhilb(n)`

It turns out that the first of these, which involves representing fractions like  $1/3$  and  $1/5$  in floating-point, is the most significant.

**Examples** `invhilb(4)` is

|      |       |       |       |
|------|-------|-------|-------|
| 16   | -120  | 240   | -140  |
| -120 | 1200  | -2700 | 1680  |
| 240  | -2700 | 6480  | -4200 |
| -140 | 1680  | -4200 | 2800  |

**References** [1] Forsythe, G. E. and C. B. Moler, *Computer Solution of Linear Algebraic Systems*, Prentice-Hall, 1967, Chapter 19.

**See Also** `hilb`

**Purpose** Invoke method on COM object or interface, or display methods

**Syntax**

```
S = h.invoke
S = h.invoke('methodname')
S = h.invoke('methodname',arg1,arg2, ...)
S = h.invoke('custominterfacename')
S = invoke(h,...)
```

**Description** `S = h.invoke` returns structure array `S` containing a list of all methods supported by the object or interface, `h`, along with the prototypes for these methods. If `S` is empty, either there are no properties or methods in the object, or the MATLAB software cannot read the object's type library. Refer to the COM vendor's documentation.

`S = h.invoke('methodname')` invokes the method specified in the string `methodname`, and returns an output value, if any, in `S`. The data type of the return value depends on the invoked method, which is determined by the control or server.

`S = h.invoke('methodname',arg1,arg2, ...)` invokes the method specified in the string `methodname` with input arguments `arg1`, `arg2`, etc.

`S = h.invoke('custominterfacename')` returns an `Interface` object `S`, which is a handle to a custom interface implemented by the COM component. The `h` argument is a handle to the COM object. The `custominterfacename` argument is a string returned by the `interfaces` function.

`S = invoke(h,...)` is an alternate syntax. For Automation objects, if the vendor provides documentation for specific properties or methods, use the `S = invoke(h, ...)` syntax to call them.

If the method returns a COM interface, then `invoke` returns a new MATLAB COM object that represents the interface returned. For a description of how MATLAB converts COM types, see "Handling COM Data in MATLAB Software".

COM functions are available on Microsoft Windows systems only.

## Examples

Invoke the Redraw method in the mwsamp control:

```
f = figure ('position', [100 200 200 200]);
h = actxcontrol ('mwsamp.mwsampctrl.1', [0 0 200 200], f);
h.Radius = 100;
h.invoke('Redraw');
```

---

Call the method directly:

```
h.Redraw;
```

---

Display all mwsamp methods:

```
h.invoke

ans =
 AboutBox = void AboutBox(handle)
 Beep = void Beep(handle)
 FireClickEvent = void FireClickEvent(handle)
 .
 .
```

## Getting a Custom Interface Example

Once you have created a COM server, you can query the server component to see if any custom interfaces are implemented. Use the `interfaces` function to return a list of all available custom interfaces:

```
h = actxserver('mytestenv.calculator');
customlist = h.interfaces

customlist =
 ICalc1
 ICalc2
 ICalc3
```



To get a handle to the custom interface you want, use the `invoke` function, specifying the handle returned by `actxcontrol` or `actxserver` and also the name of the custom interface:

```
c1 = h.invoke('ICalc1')

c1 =
 Interface.Calc_1.0_Type_Library.ICalc_Interface
```

You can now use this handle with most of the COM client functions to access the properties and methods of the object through the selected custom interface.

**See Also**

`methods` | `ismethod` | `interfaces`

**How To**

- “Handling COM Data in MATLAB Software”
- “Custom Interfaces”

# ipermute

---

**Purpose** Inverse permute dimensions of N-D array

**Syntax** `A = ipermute(B,order)`

**Description** `A = ipermute(B,order)` is the inverse of `permute`. `ipermute` rearranges the dimensions of `B` so that `permute(A,order)` will produce `B`. `B` has the same values as `A` but the order of the subscripts needed to access any particular element are rearranged as specified by `order`. All the elements of `order` must be unique.

**Tips** `permute` and `ipermute` are a generalization of transpose (`.'`) for multidimensional arrays.

**Examples** Consider the 2-by-2-by-3 array `a`:

```
a = cat(3,eye(2),2*eye(2),3*eye(2))
```

```
a(:,:,1) = a(:,:,2) =
 1 0 2 0
 0 1 0 2
```

```
a(:,:,3) =
 3 0
 0 3
```

Permuting and inverse permuting `a` in the same fashion restores the array to its original form:

```
B = permute(a,[3 2 1]);
C = ipermute(B,[3 2 1]);
isequal(a,C)
ans=
```

```
1
```

**See Also** `permute`

**Purpose** Detect state

**Description** These functions detect the state of MATLAB entities:

|               |                                                                   |
|---------------|-------------------------------------------------------------------|
| isa           | Detect object of given MATLAB class or Java class                 |
| isappdata     | Determine if object has specific application-defined data         |
| iscategorical | Determine whether input is categorical array                      |
| iscategory    | Test for categorical array categories                             |
| iscell        | Determine if input is cell array                                  |
| iscellstr     | Determine if input is cell array of strings                       |
| ischar        | Determine if input is character array                             |
| iscolumn      | Determine whether input is column vector                          |
| iscom         | Determine if input is Component Object Model (COM) object         |
| isdir         | Determine if input is folder                                      |
| isempty       | Determine if input is empty array                                 |
| isequal       | Determine if arrays are numerically equal                         |
| isequaln      | Determine if arrays are numerically equal, treating NaNs as equal |
| isevent       | Determine if input is Component Object Model (COM) object event   |
| isfield       | Determine if input is MATLAB structure array field                |
| isfinite      | Detect finite elements of array                                   |
| isfloat       | Determine if input is floating-point array                        |
| isglobal      | Determine if input is global variable                             |
| ishandle      | Detect valid graphics object handles                              |
| ishold        | Determine if graphics hold state is on                            |

|             |                                                                 |
|-------------|-----------------------------------------------------------------|
| isinf       | Detect infinite elements of array                               |
| isinteger   | Determine if input is integer array                             |
| isinterface | Determine if input is Component Object Model (COM) interface    |
| isjava      | Determine if input is Java object                               |
| iskeyword   | Determine if input is MATLAB keyword                            |
| isletter    | Detect elements that are alphabetic letters                     |
| islogical   | Determine if input is logical array                             |
| ismac       | Determine if running MATLAB for Macintosh OS X platform         |
| ismatrix    | Determine whether input is matrix                               |
| ismember    | Detect members of specific set                                  |
| ismethod    | Determine if input is object method                             |
| ismissing   | Find table elements with missing values                         |
| isnan       | Detect elements of array that are not a number (NaN)            |
| isnumeric   | Determine if input is numeric array                             |
| isobject    | Determine if input is MATLAB object                             |
| isordinal   | Determine whether input is ordinal categorical array            |
| ispc        | Determine if running MATLAB for PC (Windows) platform           |
| isprime     | Detect prime elements of array                                  |
| isprop      | Determine if input is object property                           |
| isprotected | Determine whether categories of categorical array are protected |
| isreal      | Determine if all array elements are real numbers                |
| isrow       | Determine whether input is row vector                           |

|             |                                               |
|-------------|-----------------------------------------------|
| isscalar    | Determine if input is scalar                  |
| issorted    | Determine if set elements are in sorted order |
| isspace     | Detect space characters in array              |
| issparse    | Determine if input is sparse array            |
| isstrprop   | Determine if string is of specified category  |
| isstruct    | Determine if input is MATLAB structure array  |
| isstudent   | Determine if Student Version of MATLAB        |
| istable     | Determine whether input is table              |
| isundefined | Find undefined elements in categorical array  |

## is\*

---

|           |                                                             |
|-----------|-------------------------------------------------------------|
| isunix    | Determine if running MATLAB for UNIX <sup>4</sup> platform. |
| isvarname | Determine if input is valid variable name                   |
| isvector  | Determine if input is vector                                |

### See Also

isa | exist

4. UNIX is a registered trademark of The Open Group in the United States and other countries.

**Purpose** Determine if input is object of specified class

**Syntax**

```
tf = isa(obj,ClassName)
tf = isa(obj,classCategory)
```

**Description** `tf = isa(obj,ClassName)` returns true if `obj` is an instance of the class specified by `ClassName`, and false otherwise. `isa` also returns true if `obj` is an instance of a class that is derived from `ClassName`.

`obj` can be any MATLAB variable.

`ClassName` can be any of the following:

- Name of any MATLAB class or fundamental type
- Name of a Java, or .NET class

### **MATLAB Fundamental Types**

|           |                         |
|-----------|-------------------------|
| 'single'  | Single-precision number |
| 'double'  | Double-precision number |
| 'int8'    | Signed 8-bit integer    |
| 'int16'   | Signed 16-bit integer   |
| 'int32'   | Signed 32-bit integer   |
| 'int64'   | Signed 64-bit integer   |
| 'uint8'   | Unsigned 8-bit integer  |
| 'uint16'  | Unsigned 16-bit integer |
| 'uint32'  | Unsigned 32-bit integer |
| 'uint64'  | Unsigned 64-bit integer |
| 'logical' | Logical true or false   |
| 'char'    | Character or string     |
| 'struct'  | Structure array         |

```
'cell' Cell array
'function_handle' function handle
```

`tf = isa(obj, classCategory)` returns true if `obj` is an instance of any of the classes in the specified `classCategory`, and false otherwise. `isa` also returns true if `obj` is an instance of a class that is derived from any of the classes in `classCategory`.

`classCategory` can be 'numeric', 'float', or 'integer', representing a category of numeric types:

## Categories of Numeric Types

```
'numeric' Integer or floating-point array (double, single,
 int8, uint8, int16, uint16, int32, uint32,
 int64, uint64)
'float' Single- or double-precision floating-point array
 (double, single)
'integer' Signed or unsigned integer array (int8, uint8,
 int16, uint16, int32, uint32, int64, uint64)
```

To test for a sparse array, use `issparse`. To test for a complex array, use `~isreal`.

## Examples

These examples show the values returned by `isa` when passed different types:

Determine if the value returned by the `pi` function is of class `double`:

```
isa(pi, 'double')
ans =
 1
```

More generally, determine if the value returned by the `pi` function is a numeric value:

```
isa(pi, 'numeric')
```



```
ans =
 1
```

`isa` also returns `true` for the `float` category because the class `double` is a floating-point type. However, `pi` does not return an integer type:

```
isa(pi, 'integer')
ans =
 0
```

Determine if the 2-by-3 array returned by `true` is of type `logical`:

```
isa(true(2,3), 'logical')
ans =
 1
```

Identify an instance of the MATLAB `containers.Map` class:

```
mapObj = containers.Map({'Color', 'RGB'},...
 {'Yellow', uint8([255,255,0])});
isa(mapObj, 'containers.Map')
ans =
 1
```

The map key, `RGB`, references a `uint8` array:

```
isa(mapObj('RGB'), 'integer')
ans =
 1
```

Specifying a particular integer class provides more specific testing:

```
if strcmp(mapObj('Color'), 'Yellow') && isa(mapObj('RGB'), 'uint8')
 % The Color is Yellow and the RGB numbers are uint8 values
 ...
end
```

## See Also

`class` | `is*` | `isnumeric` | `isfloat` | `isinteger` | `exist`

# isappdata

---

**Purpose** True if application-defined data exists

**Syntax** `isappdata(h,name)`

**Description** `isappdata(h,name)` returns 1 if application-defined data with the specified name exists on the object specified by handle `h`, and returns 0 otherwise.

**Tips** Application data is data that is meaningful to or defined by your application which you attach to a figure or any GUI component (other than ActiveX controls) through its `AppData` property. Only Handle Graphics MATLAB objects use this property.

**See Also** `getappdata` | `rmappdata` | `setappdata`

|                        |                                                                                                                                                                                                                                                                                                                                                                                                                                                                                                                                                                                                                                                                                                                                                                                                                                                                                                                                                                                                            |
|------------------------|------------------------------------------------------------------------------------------------------------------------------------------------------------------------------------------------------------------------------------------------------------------------------------------------------------------------------------------------------------------------------------------------------------------------------------------------------------------------------------------------------------------------------------------------------------------------------------------------------------------------------------------------------------------------------------------------------------------------------------------------------------------------------------------------------------------------------------------------------------------------------------------------------------------------------------------------------------------------------------------------------------|
| <b>Purpose</b>         | Determine if matrix is within specific bandwidth                                                                                                                                                                                                                                                                                                                                                                                                                                                                                                                                                                                                                                                                                                                                                                                                                                                                                                                                                           |
| <b>Syntax</b>          | <code>tf = isbanded(A,lower,upper)</code>                                                                                                                                                                                                                                                                                                                                                                                                                                                                                                                                                                                                                                                                                                                                                                                                                                                                                                                                                                  |
| <b>Description</b>     | <code>tf = isbanded(A,lower,upper)</code> returns logical 1 (true) if matrix A is within the specified lower bandwidth, <code>lower</code> , and upper bandwidth, <code>upper</code> ; otherwise, it returns logical 0 (false).                                                                                                                                                                                                                                                                                                                                                                                                                                                                                                                                                                                                                                                                                                                                                                            |
| <b>Input Arguments</b> | <p><b>A - Input array</b><br/>numeric array</p> <p>Input array, specified as a numeric array. <code>isbanded</code> returns logical 0 (false) if A has more than two dimensions.</p> <p><b>Data Types</b><br/>single   double</p> <p><b>Complex Number Support:</b> Yes</p> <p><b>lower - Lower bandwidth</b><br/>nonnegative integer scalar</p> <p>Lower bandwidth, specified as a nonnegative integer scalar. The lower bandwidth is the number of nonzero diagonals below the main diagonal. <code>isbanded</code> returns logical 0 (false) if there are nonzero elements below the boundary diagonal, <code>diag(A,-lower)</code>.</p> <p><b>upper - Upper bandwidth</b><br/>nonnegative integer scalar</p> <p>Upper bandwidth, specified as a nonnegative integer scalar. The upper bandwidth is the number of nonzero diagonals above the main diagonal. <code>isbanded</code> returns logical 0 (false) if there are nonzero elements above the boundary diagonal, <code>diag(A,upper)</code>.</p> |
| <b>Examples</b>        | <p><b>Test Square Matrix</b></p> <p>Create a 5-by-5 square matrix.</p> <pre>A = [2 3 0 0 0 ; 1 -2 -3 0 0; 0 -1 2 3 0 ; 0 0 1 -2 -3; 0 0 0 -1 2 ]</pre>                                                                                                                                                                                                                                                                                                                                                                                                                                                                                                                                                                                                                                                                                                                                                                                                                                                     |

# isbanded

---

A =

```
 2 3 0 0 0
 1 -2 -3 0 0
 0 -1 2 3 0
 0 0 1 -2 -3
 0 0 0 -1 2
```

The result is a square matrix with nonzero diagonals above and below the main diagonal.

Specify both bandwidths, lower and upper, as 1 to test if A is tridiagonal.

```
isbanded(A,1,1)
```

ans =

```
 1
```

The result is logical 1 (true).

Test if A has nonzero elements below the main diagonal by specifying lower as 0.

```
isbanded(A,0,1)
```

ans =

```
 0
```

The result is logical 0 (false) because A has nonzero elements below the main diagonal.

## Test Nonsquare Matrix

Create a 3-by-5 matrix.

```
A = [1 0 0 0 0; 2 1 0 0 0; 3 2 1 0 0]
```

```
A =
```

```
 1 0 0 0 0
 2 1 0 0 0
 3 2 1 0 0
```

The result is a rectangular matrix.

Test if A has nonzero elements above the main diagonal.

```
isbanded(A,2,0)
```

```
ans =
```

```
 1
```

The result is logical 1 (true) because the elements above the main diagonal are all zero.

### Test Sparse Block Matrix

Create a 100-by-100 sparse block matrix.

```
B = kron(speye(25),ones(4));
```

Test if B has a lower and upper bandwidth of 1.

```
isbanded(B,1,1)
```

```
ans =
```

```
 0
```

The result is logical 0 (false) because the nonzero blocks centered on the main diagonal are larger than 2-by-2.

Test if B has a lower and upper bandwidth of 3.

```
isbanded(B,3,3)
```

# isbanded

```
ans =
```

```
1
```

The result is logical 1 (true). The matrix, B, has an upper and lower bandwidth of 3 since the nonzero diagonal blocks are 4-by-4.

## Tips

- Use the bandwidth function to find the upper and lower bandwidths of a given matrix.
- Use `isbanded` to test for several different matrix structures by specifying appropriate upper and lower bandwidths. The table below lists some common tests.

| Lower Bandwidth        | Upper Bandwidth        | Function Call                        | Tests for               |
|------------------------|------------------------|--------------------------------------|-------------------------|
| 0                      | 0                      | <code>isbanded(A,0,0)</code>         | Diagonal matrix         |
| 1                      | 1                      | <code>isbanded(A,1,1)</code>         | Tridiagonal matrix      |
| 0                      | <code>size(A,2)</code> | <code>isbanded(A,0,size(A,2))</code> | Upper triangular matrix |
| <code>size(A,1)</code> | 0                      | <code>isbanded(A,size(A,1),0)</code> | Lower triangular matrix |
| 1                      | <code>size(A,2)</code> | <code>isbanded(A,1,size(A,2))</code> | Upper Hessenberg matrix |
| <code>size(A,1)</code> | 1                      | <code>isbanded(A,size(A,1),1)</code> | Lower Hessenberg matrix |

## See Also

`bandwidth` | `diag` | `isdiag` | `istriu` | `istril`

**Purpose** Determine whether input is categorical array

**Syntax** `tf = iscategorical(A)`

**Description** `tf = iscategorical(A)` returns logical 1 (true) if *A* is a categorical array. Otherwise, `iscategorical` returns logical 0 (false).

**Input Arguments** **A - Input variable**  
workspace variable

Input variable, specified as a workspace variable. *A* can be any data type.

**Examples** **Determine Whether Workspace Variable Is Categorical Array**

Create a workspace variable, *A*.

```
A = categorical({'red' 'green' 'violet'; 'orange' 'red' 'yellow'})
```

```
A =
```

```
 red green violet
orange red yellow
```

Verify that the workspace variable, *A*, is a categorical array.

```
tf = iscategorical(A)
```

```
tf =
```

```
 1
```

*A* is a 2-by-3 categorical array.

**See Also** `categorical` | `isnumeric` | `isobject` | `islogical` | `istable` | `iscell` | `isstruct`

# iscategory

---

**Purpose** Test for categorical array categories

**Syntax** `tf = iscategory(A,catnames)`

**Description** `tf = iscategory(A,catnames)` returns an array containing logical 1 (true) where the data in `catnames` is a category of `A`. Otherwise, `iscategory` returns logical 0 (false).

`tf` is the same size as `catnames`.

## Input Arguments

### **A - Categorical array**

vector | matrix | multidimensional array

Categorical array, specified as a vector, matrix, or multidimensional array.

### **catnames - Category names**

string | cell array of strings | categorical array

Category names, specified as a string, cell array of strings, or categorical array.

## Examples

### **Test for Categories**

Create an ordinal categorical array, `A`.

```
A = categorical({'shirt' 'pants'; 'pants' 'hat'; 'shirt' 'pants'})
```

```
A =
```

```
 shirt pants
 pants hat
 shirt pants
```

`A` is a 1-by-5 categorical array.

Test if the articles of clothing, `shirt`, `pants`, `socks`, and `shoes`, are categories of `A`.



```
catnames = {'shirt' 'pants' 'socks' 'shoes'};
tf = iscategory(A,catnames)
```

```
tf =
```

```
 1 1 0 0
```

shirt and pants are categories of A, but socks, and shoes are not.

iscategory does not tell us anything about the category, hat, which we did not include in catnames.

### Test for Category with No Corresponding Data

Create a categorical array, A.

```
A = categorical({'plane' 'car' 'train' 'car' 'plane'},...
 {'boat' 'car' 'plane' 'train'})
```

```
A =
```

```
 plane car train car plane
```

A is a 1-by-5 categorical array.

Test to see if boat is a category in A.

```
tf = iscategory(A,'boat')
```

```
tf =
```

```
 1
```

iscategory returns true, even though A does not contain any values from the category boat.

### See Also

categories | categorical | removecats | mergecats | renamecats | reordercats | ismember | unique

# iscell

---

**Purpose** Determine whether input is cell array

**Syntax** `tf = iscell(A)`

**Description** `tf = iscell(A)` returns logical 1 (true) if `A` is a cell array and logical 0 (false) otherwise.

**Examples**

```
A{1,1} = [1 4 3; 0 5 8; 7 2 9];
A{1,2} = 'Anne Smith';
A{2,1} = 3+7i;
A{2,2} = -pi:pi/10:pi;
```

```
iscell(A)
```

```
ans =
```

```
1
```

**See Also** `cell` | `istable` | `iscellstr` | `isstruct` | `isnumeric` | `islogical` | `isobject` | `isa` | `is*`

**Purpose** Determine whether input is cell array of strings

**Syntax** `tf = iscellstr(A)`

**Description** `tf = iscellstr(A)` returns logical 1 (true) if `A` is a cell array of strings (or an empty cell array), and logical 0 (false) otherwise. A cell array of strings is a cell array where every element is a character array.

**Examples**

```
A{1,1} = 'Thomas Lee';
A{1,2} = 'Marketing';
A{2,1} = 'Allison Jones';
A{2,2} = 'Development';
```

```
iscellstr(A)
```

```
ans =
```

```
1
```

**See Also** `cellstr` | `istable` | `iscategorical` | `iscell` | `isstrprop` | `strings`  
| `char` | `isstruct` | `isa` | `is*`

# ischar

---

**Purpose** Determine whether item is character array

**Syntax** `tf = ischar(A)`

**Description** `tf = ischar(A)` returns logical 1 (true) if A is a character array and logical 0 (false) otherwise.

**Examples** Given the following cell array,

```
C{1,1} = magic(3); % double array
C{1,2} = 'John Doe'; % char array
C{1,3} = 2 + 4i % complex double
```

```
C =
```

```
 [3x3 double] 'John Doe' [2.0000+ 4.0000i]
```

`ischar` shows that only `C{1,2}` is a character array.

```
for k = 1:3
x(k) = ischar(C{1,k});
end
```

```
x
```

```
x =
```

```
 0 1 0
```

**See Also** `char` | `strings` | `isletter` | `isspace` | `isstrprop` | `iscellstr` | `isnumeric` | `isa` | `is*`

**Purpose** Determine whether input is column vector

**Syntax** `iscolumn(V)`

**Description** `iscolumn(V)` returns logical 1 (true) if `size(V)` returns `[n 1]` with a nonnegative integer value `n`, and logical 0 (false) otherwise.

**Examples** Determine if a vector is a column. This example is a row so `iscolumn` returns 0:

```
V = rand(1,5);
iscolumn(V)
ans =
 0
```

Transpose the vector to make it a column. `iscolumn` returns 1:

```
V1 = V';
iscolumn(V1)
ans =
 1
```

**See Also** `ismatrix` | `isrow` | `isscalar` | `isvector`

**Purpose** Determine whether input is COM or ActiveX object

**Syntax**

```
tf = h.iscom
tf = iscom(h)
```

**Description** `tf = h.iscom` returns logical 1 (true) if handle `h` is a COM or Microsoft ActiveX object. Otherwise, returns logical 0 (false).

`tf = iscom(h)` is an alternate syntax.

COM functions are available on Microsoft Windows systems only.

**Examples** Test an instance of a Microsoft Excel application:

```
h = actxserver('Excel.Application');
h.iscom
```

MATLAB displays `true`, indicating object `h` is a COM object.

---

Test an Excel interface:

```
h = actxserver('Excel.Application');
%Create a workbooks object
w = h.get('workbooks');
w.iscom
```

MATLAB displays `false`, indicating object `w` is not a COM object.

**How To**

- “MATLAB COM Integration”

**Purpose** Determine if matrix is diagonal

**Syntax** `tf = isdiag(A)`

**Description** `tf = isdiag(A)` returns logical 1 (true) if A is a diagonal matrix; otherwise, it returns logical 0 (false).

**Input Arguments**

**A - Input array**

numeric array

Input array, specified as a numeric array. `isdiag` returns logical 0 (false) if A has more than two dimensions.

**Data Types**

single | double

**Complex Number Support:** Yes

**Examples**

**Test Diagonal Matrix**

Create a 4-by-4 identity matrix.

```
I = eye(4)
```

```
I =
```

```

 1 0 0 0
 0 1 0 0
 0 0 1 0
 0 0 0 1

```

Test to see if the matrix is diagonal.

```
isdiag(I)
```

```
ans =
```

```

 1

```

The result is logical 1 (true) because all of the nonzero elements in I are on the main diagonal.

## Test Banded Matrix

Create a matrix with nonzero elements on the main and first diagonals.

```
A = 3*eye(4) + diag([2 2 2],1)
```

```
A =
```

```
 3 2 0 0
 0 3 2 0
 0 0 3 2
 0 0 0 3
```

Test to see if the matrix is diagonal.

```
isdiag(A)
```

```
ans =
```

```
 0
```

The matrix is not diagonal since there are nonzero elements above the main diagonal.

Create a new matrix, B, from the main diagonal elements of A.

```
B = diag(diag(A));
```

Test to see if B is a diagonal matrix.

```
isdiag(B)
```

```
ans =
```

```
 1
```



The result is logical 1 (true) because there are no nonzero elements above or below the main diagonal of B.

## Definitions **Diagonal Matrix**

A matrix is diagonal if all elements above and below the main diagonal are zero. Any number of the elements on the main diagonal can also be zero.

For example, the 4-by-4 identity matrix,

$$I_4 = \begin{pmatrix} 1 & 0 & 0 & 0 \\ 0 & 1 & 0 & 0 \\ 0 & 0 & 1 & 0 \\ 0 & 0 & 0 & 1 \end{pmatrix}$$

is a diagonal matrix. Diagonal matrices are typically, but not always, square.

## Tips

- Use the `diag` function to produce diagonal matrices for which `isdiag` returns logical 1 (true).
- The functions `isdiag`, `istriu`, and `istril` are special cases of the function `isbanded`, which can perform all of the same tests with suitably defined upper and lower bandwidths. For example, `isdiag(A) == isbanded(A,0,0)`.

## See Also

`istril` | `istriu` | `tril` | `triu` | `diag`

# isdir

---

**Purpose** Determine whether input is folder

**Syntax** `tf = isdir('A')`

**Description** `tf = isdir('A')` returns logical 1 (true) if A is a folder. Otherwise, it returns logical 0 (false).

**Examples** Run:  
`tf=isdir('myfiles/results')`

MATLAB returns

```
tf =
 1
```

indicating that myfiles/results is a folder.

**See Also** `dir` | `is*`

**Purpose** (Will be removed) Test if vertices are joined by edge

---

**Note** `isEdge(TriRep)` will be removed in a future release. Use `isConnected(triangulation)` instead.

---

`TriRep` will be removed in a future release. Use `triangulation` instead.

---

**Syntax**

```
TF = isEdge(TR, V1, V2)
TF = isEdge(TR, EDGE)
```

**Description**

`TF = isEdge(TR, V1, V2)` returns an array of 1/0 (true/false) flags, where each entry `TF(i)` is true if `V1(i), V2(i)` is an edge in the triangulation. `V1, V2` are column vectors representing the indices of the vertices in the mesh, that is, indices into the vertex coordinate arrays.

`TF = isEdge(TR, EDGE)` specifies the edge start and end indices in matrix format.

**Input Arguments**

|        |                                                             |
|--------|-------------------------------------------------------------|
| TR     | Triangulation representation.                               |
| V1, V2 | Column vectors of mesh vertices.                            |
| EDGE   | Matrix of size n-by-2 where n is the number of query edges. |

**Output Arguments**

|    |                                                                                                                                            |
|----|--------------------------------------------------------------------------------------------------------------------------------------------|
| TF | Array of 1/0 (true/false) flags, where each entry <code>TF(i)</code> is true if <code>V1(i), V2(i)</code> is an edge in the triangulation. |
|----|--------------------------------------------------------------------------------------------------------------------------------------------|

**Examples**

**Example 1**

Load a 2-D triangulation and use `TriRep` to query the presence of an edge between pairs of points.

```
load trimesh2d
trep = TriRep(tri, x,y);
```

Test if vertices 3 and 117 are connected by an edge

```
isEdge(trep, 3, 117)
```

Test if vertices 3 and 164 are connected by an edge

```
isEdge(trep, 3, 164)
```

## Example 2

Direct query of a 3-D Delaunay triangulation created using DelaunayTri.

```
X = rand(10,3)
dt = DelaunayTri(X)
```

Test if vertices 2 and 7 are connected by an edge

```
isEdge(dt, 2, 7);
```

## See Also

[delaunayTriangulation](#) | [triangulation](#)

|                    |                                                                                                                                                                                                                   |
|--------------------|-------------------------------------------------------------------------------------------------------------------------------------------------------------------------------------------------------------------|
| <b>Purpose</b>     | Determine whether array is empty                                                                                                                                                                                  |
| <b>Syntax</b>      | <code>TF = isempty(A)</code>                                                                                                                                                                                      |
| <b>Description</b> | <code>TF = isempty(A)</code> returns logical 1 (true) if <code>A</code> is an empty array and logical 0 (false) otherwise. An empty array has at least one dimension of size zero, for example, 0-by-0 or 0-by-5. |
| <b>Examples</b>    | <pre>B = rand(2,2,2);<br/>B(:,:,:) = [];<br/><br/>isempty(B)<br/><br/>ans = 1</pre>                                                                                                                               |
| <b>See Also</b>    | <code>is*</code>                                                                                                                                                                                                  |

# isempty (tscollection)

---

**Purpose** Determine whether tscollection object is empty

**Syntax** isempty(tsc)

**Description** isempty(tsc) returns a logical value for tscollection object tsc, as follows:

- 1 — When tsc contains neither timeseries members nor a time vector
- 0 — When tsc contains either timeseries members or a time vector

**See Also** timeseries | tscollection | length (tscollection) | size (tscollection)

|                        |                                                                                                                                                                                                                                                                                                                                                                                                                                                                                                                                                                                                                                                                                                                                                                                                                            |
|------------------------|----------------------------------------------------------------------------------------------------------------------------------------------------------------------------------------------------------------------------------------------------------------------------------------------------------------------------------------------------------------------------------------------------------------------------------------------------------------------------------------------------------------------------------------------------------------------------------------------------------------------------------------------------------------------------------------------------------------------------------------------------------------------------------------------------------------------------|
| <b>Purpose</b>         | Determine array equality                                                                                                                                                                                                                                                                                                                                                                                                                                                                                                                                                                                                                                                                                                                                                                                                   |
| <b>Syntax</b>          | <pre>tf = isequal(A,B) tf = isequal(A1,A2,...,An)</pre>                                                                                                                                                                                                                                                                                                                                                                                                                                                                                                                                                                                                                                                                                                                                                                    |
| <b>Description</b>     | <p><code>tf = isequal(A,B)</code> returns logical 1 (true) if A and B are the same size and their contents are of equal value; otherwise, it returns logical 0 (false). The test compares both real and imaginary parts of numeric arrays. <code>isequal</code> ignores the data type of the values in determining whether they are equal. For cell arrays, categorical arrays, tables, or structures, the function returns logical 1 (true) only when all elements and properties are numerically equal. Undefined categorical elements or NaN (not a number) values are considered to be unequal to other elements, as well as themselves.</p> <p><code>tf = isequal(A1,A2,...,An)</code> returns logical 1 (true) if all the inputs are numerically equal.</p>                                                          |
| <b>Input Arguments</b> | <p><b>A,B - Inputs to be compared</b><br/>numeric arrays   categorical arrays   cell arrays   tables   structures<br/>  ...</p> <p>Inputs to be compared, specified as numeric arrays, categorical arrays, cell arrays, tables, or structures. Also, you can specify the inputs as logical arrays, character arrays, or objects. The numeric types of A and B do not have to match.</p> <p>You can compare a categorical array to a cell array of strings of the same size, or a single categorical element to a single string.</p> <p>If inputs A and B are <i>both</i></p> <ul style="list-style-type: none"><li>• Structures -- Fields need not be in the same order as long as the contents are equal.</li><li>• Ordinal categorical arrays -- Must have the same sets of categories, including their order.</li></ul> |

# isequal

---

- Categorical arrays that are not ordinal -- Can have different sets of categories, and `isequal` compares the category names of each pair of elements.
- Objects of different classes -- `isequal` returns logical 0 (false). This applies even when the objects have the same properties and their values match.

## **A1,A2,...,An - Series of inputs to be compared**

numeric arrays | categorical arrays | cell arrays | tables | structures  
| ...

Series of inputs to be compared, specified as numeric arrays, categorical arrays, cell arrays, tables, or structures. Also, you can specify the inputs as logical arrays, character arrays, or objects. The numeric types of the inputs do not have to match.

You can compare categorical arrays to cell arrays of strings of the same size, or single categorical elements to single strings.

If the inputs are *all*

- Structures -- Fields need not be in the same order as long as the contents are equal.
- Ordinal categorical arrays -- Must have the same sets of categories, including their order.
- Categorical arrays that are not ordinal -- Can have different sets of categories, and `isequal` compares the category names of each pair of elements.
- Objects of different classes -- `isequal` returns logical 0 (false). This applies even when the objects have the same properties and their values match.

## **Examples**

### **Compare Two Numeric Matrices**

Create two numeric matrices and compare them for equality.

```
A = zeros(3,3)+1e-20;
```



```
B = zeros(3,3);
tf = isequal(A,B)
```

```
tf =

 0
```

The function returns logical 0 (false) because the matrices differ by a very small amount and are not *exactly* equal.

### Compare Two Structures

Create two structures and specify the fields in a different order.

```
A = struct('field1',0.005,'field2',2500);
B = struct('field2',2500,'field1',0.005);
```

Compare the structures for equality.

```
tf = isequaln(A,B)

tf =

 1
```

Even though the ordering of the fields in each structure is different, `isequal` treats them as the same because the values are equal.

### Comparing Numeric Values with Special Nonnumeric Values

Compare the logical value true to the double integer 1.

```
isequal(true,1)

ans =

 1
```

# isequal

---

Notice that `isequal` does not consider data type when it tests for equality.

Similarly, compare 'A' to the ASCII-equivalent integer, 65.

```
isequal('A',65)
```

```
ans =
```

```
1
```

The result is logical 1 (true) since `double('A')` equals 65.

## Compare Vectors Containing NaN Values

Create three vectors containing NaN values.

```
A1 = [1 NaN NaN];
```

```
A2 = [1 NaN NaN];
```

```
A3 = [1 NaN NaN];
```

Compare the vectors for equality.

```
tf = isequal(A1,A2,A3)
```

```
tf =
```

```
0
```

The result is logical 0 (false) because `isequal` does not treat NaN values as equal to each other.

## Tips

- When comparing handle objects, use `==` to test whether objects have the same handle. Use `isequal` to determine if objects with different handles have equal property values.
- Use `isequaln` if you want to test for equality and treat NaN values as equal.

**See Also**      `isequaln` | `eq` | `is*` | `isa*` | `strcmp` | relational operators

# isequaln

---

**Purpose** Determine array equality, treating NaN values as equal

**Syntax**  
`tf = isequaln(A,B)`  
`tf = isequaln(A1,A2,...,An)`

**Description** `tf = isequaln(A,B)` returns logical 1 (true) if A and B are the same size and their contents are of equal value; otherwise, it returns logical 0 (false). The test compares both real and imaginary parts of numeric arrays. `isequaln` ignores the data type of the values in determining whether they are equal. For cell arrays, categorical arrays, tables, or structures, the function returns logical 1 (true) only when all elements and properties are numerically equal. Undefined categorical elements or NaN (not a number) values are considered to be equal to other such values.

`tf = isequaln(A1,A2,...,An)` returns logical 1 (true) if all the inputs are numerically equal.

## Input Arguments

### A,B - Inputs to be compared

numeric arrays | categorical arrays | cell arrays | tables | structures  
| ...

Inputs to be compared, specified as numeric arrays, categorical arrays, cell arrays, tables, or structures. Also, you can specify the inputs as logical arrays, character arrays, or objects. The numeric types of A and B do not have to match.

You can compare a categorical array to a cell array of strings of the same size, or a single categorical element to a single string.

If inputs A and B are *both*

- Structures -- Fields need not be in the same order as long as the contents are equal.
- Ordinal categorical arrays -- Must have the same sets of categories, including their order.

- Categorical arrays that are not ordinal -- Can have different sets of categories, and `isequaln` compares the category names of each pair of elements.
- Objects of different classes -- `isequaln` returns logical 0 (false). This applies even when the objects have the same properties and their values match.

### **A1,A2,...,An - Series of inputs to be compared**

numeric arrays | categorical arrays | cell arrays | tables | structures  
| ...

Series of inputs to be compared, specified as numeric arrays, categorical arrays, cell arrays, tables, or structures. Also, you can specify the inputs as logical arrays, character arrays, or objects. The numeric types of the inputs do not have to match.

You can compare categorical arrays to cell arrays of strings of the same size, or single categorical elements to single strings.

If the inputs are *all*

- Structures -- Fields need not be in the same order as long as the contents are equal.
- Ordinal categorical arrays -- Must have the same sets of categories, including their order.
- Categorical arrays that are not ordinal -- Can have different sets of categories, and `isequaln` compares the category names of each pair of elements.
- Objects of different classes -- `isequaln` returns logical 0 (false). This applies even when the objects have the same properties and their values match.

## **Examples**

### **Compare Two Numeric Matrices**

Create two numeric matrices and compare them for equality.

```
A = zeros(3,3)+1e-20;
```

# isequaln

---

```
B = zeros(3,3);
tf = isequaln(A,B)
```

```
tf =
```

```
0
```

The function returns logical 0 (false) because the matrices differ by a very small amount and are not *exactly* equal.

## Compare Two Structures

Create two structures and specify the fields in a different order.

```
A = struct('field1',0.005,'field2',2500);
B = struct('field2',2500,'field1',0.005);
```

Compare the structures for equality.

```
tf = isequaln(A,B)
```

```
tf =
```

```
1
```

Even though the ordering of the fields in each structure is different, `isequaln` treats them as the same because the values are equal.

## Comparing Numeric Values with Special Nonnumeric Values

Compare the logical value `true` to the double integer 1.

```
isequaln(true,1)
```

```
ans =
```

```
1
```

Notice that `isequaln` does not consider data type when it tests for equality.

Similarly, compare 'A' to the ASCII-equivalent integer, 65.

```
isequaln('A',65)
```

```
ans =
```

```
1
```

The result is logical 1 (true) since `double('A')` equals 65.

### Compare Vectors Containing NaN Values

Create three vectors containing NaN values.

```
A1 = [1 NaN NaN];
```

```
A2 = [1 NaN NaN];
```

```
A3 = [1 NaN NaN];
```

Compare the vectors for equality.

```
tf = isequaln(A1,A2,A3)
```

```
tf =
```

```
1
```

The result is logical 1 (true) because `isequaln` treats the NaN values as equal to each other.

### Tips

- When comparing handle objects, use `==` to test whether objects have the same handle. Use `isequaln` to treat NaN values as equal and determine if objects with different handles have equal property values.
- Use `isequal` if you want to test for equality and treat NaN values as unequal.

# isequaln

---

## **See Also**

isequal | eq | is\* | isa\* | strcmp | relational operators



|                    |                                                                                                                                                                                                                                       |
|--------------------|---------------------------------------------------------------------------------------------------------------------------------------------------------------------------------------------------------------------------------------|
| <b>Purpose</b>     | Compare scalar MException objects for equality                                                                                                                                                                                        |
| <b>Syntax</b>      | TF = isequal(eObj1, eObj2)                                                                                                                                                                                                            |
| <b>Description</b> | TF = isequal(eObj1, eObj2) tests MException objects eObj1 and eObj2 for equality, returning logical 1 (true) if the two objects are identical, otherwise returning logical 0 (false).                                                 |
| <b>See Also</b>    | last(MException)   disp(MException)   ne(MException)   eq(MException)   addCause(MException)   throwAsCaller(MException)   rethrow(MException)   throw(MException)   getReport(MException)   MException   assert   error   try, catch |

# isequalwithequalnans

---

**Purpose** Test arrays for equality, treating NaNs as equal

---

**Note** `isequalwithequalnans` is not recommended. Use `isequaln` instead.

---

**Syntax** `tf = isequalwithequalnans(A, B, ...)`

**Description** `tf = isequalwithequalnans(A, B, ...)` returns logical 1 (true) if the input arrays are the same type and size and hold the same contents, and logical 0 (false) otherwise. NaN (Not a Number) values are considered to be equal to each other. Numeric data types and structure field order do not have to match.

**Tips** `isequalwithequalnans` is the same as `isequal`, except `isequalwithequalnans` considers NaN (Not a Number) values to be equal, and `isequal` does not.

`isequalwithequalnans` recursively compares the contents of cell arrays and structures. If all the elements of a cell array or structure are numerically equal, `isequalwithequalnans` returns logical 1.

**Examples** Arrays containing NaNs are handled differently by `isequal` and `isequalwithequalnans`. `isequal` does not consider NaNs to be equal, while `isequalwithequalnans` does.

```
A = [32 8 -29 NaN 0 5.7];
B = A;
isequal(A, B)
ans =
 0
```

```
isequalwithequalnans(A, B)
ans =
 1
```

The position of NaN elements in the array does matter. If they are not in the same position in the arrays being compared, then `isequalwithequalnans` returns zero.

```
A = [2 4 6 NaN 8]; B = [2 4 NaN 6 8];
isequalwithequalnans(A, B)
ans =
 0
```

## See Also

[isequal](#) | [strcmp](#) | [isa](#) | [is\\*](#) | [relational operators](#) | [isequaln](#)

# isevent

---

**Purpose** Determine whether input is COM object event

**Syntax**

```
tf = h.isevent('eventname')
tf = isevent(h, 'eventname')
```

**Description** `tf = h.isevent('eventname')` returns logical 1 (true) if `event_name` is an event recognized by COM object `h`. Otherwise, returns logical 0 (false). The `event_name` argument is not case sensitive.

`tf = isevent(h, 'eventname')` is an alternate syntax.

COM functions are available on Microsoft Windows systems only.

**Examples** Test events in a MATLAB sample control object:

**1** Create an instance of the `mwsamp` control and test `Db1Click`:

```
f = figure('position', [100 200 200 200]);
h = actxcontrol('mwsamp.mwsampctrl.2', [0 0 200 200], f);
h.isevent('Db1Click')
```

MATLAB displays `true`, indicating `Db1Click` is an event.

**2** Try the same test on `Redraw`:

```
h.isevent('Redraw')
```

MATLAB displays `false`, indicating `Redraw` is not an event; it is a method.

---

Test events in a Microsoft Excel workbook object:

**1** Create a Workbook object `wb`:

```
myApp = actxserver('Excel.Application');
wbs = myApp.Workbooks;
wb = wbs.Add;
```

**2** Test Activate:

```
wb.isevent('Activate')
```

MATLAB displays `true`, indicating `Activate` is an event.

**3** Test Save:

```
wb.isevent('Save')
```

MATLAB displays `false`, indicating `Save` is not an event; it is a method.

**See Also**

`events (COM)` | `eventlisteners` | `registerevent`

**How To**

- “Exploring Events”
- “Functions for Working with Events”

# isfield

---

**Purpose** Determine whether input is structure array field

**Syntax**

```
tf = isfield(S, 'fieldname')
tf = isfield(S, C)
```

**Description**

`tf = isfield(S, 'fieldname')` examines structure `S` to see if it includes the field specified by the quoted string `'fieldname'`. Output `tf` is set to logical 1 (true) if `S` contains the field, or logical 0 (false) if not. If `S` is not a structure array, `isfield` returns false.

`tf = isfield(S, C)` examines structure `S` for multiple fieldnames as specified in cell array of strings `C`, and returns an array of logical values to indicate which of these fields are part of the structure. Elements of output array `tf` are set to a logical 1 (true) if the corresponding element of `C` holds a fieldname that belongs to structure `S`. Otherwise, logical 0 (false) is returned in that element. In other words, if structure `S` contains the field specified in `C{m,n}`, `isfield` returns a logical 1 (true) in `tf(m,n)`.

---

**Note** `isfield` returns false if the field or fieldnames input is empty.

---

## Examples

### Example 1 – Single Fieldname Syntax

Given the following MATLAB structure,

```
patient.name = 'John Doe';
patient.billing = 127.00;
patient.test = [79 75 73; 180 178 177.5; 220 210 205];
```

`isfield` identifies `billing` as a field of that structure.

```
isfield(patient,'billing')
ans =
 1
```

### Example 2 – Multiple Fieldname Syntax

Check structure S for any of four possible fieldnames. Only the first is found, so the first element of the return value is set to true:

```
S = struct('one', 1, 'two', 2);

fields = isfield(S, {'two', 'pi', 'One', 3.14})
fields =
 1 0 0 0
```

### See Also

fieldnames | setfield | getfield | orderfields | rmfield | struct  
| isstruct | iscell | isa | is\*

### How To

- dynamic field names

# isfinite

---

**Purpose** Array elements that are finite

**Syntax** TF = isfinite(A)

**Description** TF = isfinite(A) returns an array the same size as A containing logical 1 (true) where the elements of the array A are finite and logical 0 (false) where they are infinite or NaN. For a complex number z, isfinite(z) returns 1 if both the real and imaginary parts of z are finite, and 0 if either the real or the imaginary part is infinite or NaN. For any real A, exactly one of the three quantities isfinite(A), isinf(A), and isnan(A) is equal to one.

**Examples**

```
a = [-2 -1 0 1 2];
isfinite(1./a)
ans =
 1 1 0 1 1
isfinite(0./a)
ans =
 1 1 0 1 1
```

**See Also** isinf | isnan | is\*



**Purpose** Determine if input is floating-point array

**Syntax** `tf = isfloat(A)`

**Description** `tf = isfloat(A)` returns true if *A* is a floating-point array and false otherwise. The floating-point types are `single` and `double`, and subclasses of `single` and `double`.

### Examples

These examples show the values `isfloat` returns when passed specific types:

```
% pi returns a floating-point value
isfloat(pi)
ans =
 1
% Complex numbers are floating-point values
isfloat(3+7i)
ans =
 1
% Single-precision numbers are floating-point values
isfloat(realmax('single'))
ans =
 1
% isfloat returns a logical value
isfloat(isfloat(pi))
ans =
 0
```

**See Also** `isa` | `isinteger` | `double` | `single` | `isnumeric`

# isglobal

---

**Purpose** Determine whether input is global variable

---

**Note** Support for the `isglobal` function will be removed in a future release of the MATLAB software. See “Tips” on page 1-3512 below.

---

**Syntax** `tf = isglobal(A)`

**Description** `tf = isglobal(A)` returns logical 1 (true) if `A` has been declared to be a global variable in the context from which `isglobal` is called, and logical 0 (false) otherwise.

**Tips** `isglobal` is most commonly used in conjunction with conditional global declaration. An alternate approach is to use a pair of variables, one local and one declared global.

Instead of using

```
if condition
 global x
end
```

```
x = some_value
```

```
if isglobal(x)
 do_something
end
```

You can use

```
global gx
if condition
 gx = some_value
else
 x = some_value
end
```

```
if condition
 do_something
end
```

If no other workaround is possible, you can replace the command

```
isglobal(variable)
```

with

```
~isempty(whos('global','variable'))
```

## See Also

[global](#) | [isvarname](#) | [isa](#) | [is\\*](#)

# ishandle

---

**Purpose** Test for valid graphics or Java object handle

**Syntax** `ishandle(H)`

**Description** `ishandle(H)` returns an array whose elements are 1 where the elements of `H` are graphics or Java object handles, and 0 where they are not.

---

**Note** You should use the most specific function for your application instead of `ishandle`, as described in the following sections.

---

## **MATLAB Object Handles**

Use the `isa` function to determine the class of MATLAB objects and use the `isvalid handle` class method to determine the validity of handle objects. See “Testing Handle Validity” for information on testing for MATLAB handle objects.

## **Graphics Object Handles**

Use `ishghandle` for graphics objects.

## **Java Object Handles**

Use `isjava` for Java objects.

**See Also** `isa` | `isjava` | `ishghandle`

|                        |                                                                                                                                                                                                                                                                                                                                                                                                                                                                                                                                                                                                  |
|------------------------|--------------------------------------------------------------------------------------------------------------------------------------------------------------------------------------------------------------------------------------------------------------------------------------------------------------------------------------------------------------------------------------------------------------------------------------------------------------------------------------------------------------------------------------------------------------------------------------------------|
| <b>Purpose</b>         | Determine if matrix is Hermitian or skew-Hermitian                                                                                                                                                                                                                                                                                                                                                                                                                                                                                                                                               |
| <b>Syntax</b>          | <pre>tf = ishermitian(A) tf = ishermitian(A,skewOption)</pre>                                                                                                                                                                                                                                                                                                                                                                                                                                                                                                                                    |
| <b>Description</b>     | <p><code>tf = ishermitian(A)</code> returns logical 1 (true) if square matrix A is Hermitian; otherwise, it returns logical 0 (false).</p> <p><code>tf = ishermitian(A,skewOption)</code> specifies the type of the test. Specify <code>skewOption</code> as 'skew' to determine if A is skew-Hermitian.</p>                                                                                                                                                                                                                                                                                     |
| <b>Input Arguments</b> | <p><b>A - Input matrix</b><br/>numeric matrix</p> <p>Input matrix, specified as a numeric matrix. If A is not square, then <code>ishermitian</code> returns logical 0 (false).</p> <p><b>Data Types</b><br/>single   double<br/><b>Complex Number Support:</b> Yes</p> <p><b>skewOption - Test type</b><br/>'nonskew' (default)   'skew'</p> <p>Test type, specified as 'nonskew' (default) or 'skew'. Specify 'skew' to test whether A is skew-Hermitian. Specifying <code>ishermitian(A, 'nonskew')</code> is equivalent to <code>ishermitian(A)</code>.</p> <p><b>Data Types</b><br/>char</p> |
| <b>Examples</b>        | <p><b>Test if Symmetric Matrix Is Hermitian</b></p> <p>Create a 3-by-3 matrix.</p> <pre>A = [1 0 1i; 0 1 0; 1i 0 1]</pre> <p>A =</p>                                                                                                                                                                                                                                                                                                                                                                                                                                                             |

# ishermitian

---

```
1.0000 + 0.0000i 0.0000 + 0.0000i 0.0000 + 1.0000i
0.0000 + 0.0000i 1.0000 + 0.0000i 0.0000 + 0.0000i
0.0000 + 1.0000i 0.0000 + 0.0000i 1.0000 + 0.0000i
```

The matrix is symmetric with respect to its real-valued diagonal.

Test whether the matrix is Hermitian.

```
tf = ishermitian(A)
```

```
tf =
```

```
0
```

The result is logical 0 (false) because A is not Hermitian. In this case, A is equal to its transpose, A.', but not its complex conjugate transpose, A'.

Change the element in A(3,1) to be -1i.

```
A(3,1) = -1i;
```

Determine if the modified matrix is Hermitian.

```
tf = ishermitian(A)
```

```
tf =
```

```
1
```

The matrix, A, is now Hermitian because it is equal to its complex conjugate transpose, A'.

## Test if Matrix Is Skew-Hermitian

Create a 3-by-3 matrix.

```
A = [-1i -1 1-i; 1 -1i -1; -1-i 1 -1i]
```

A =

$$\begin{bmatrix} 0.0000 - 1.0000i & -1.0000 + 0.0000i & 1.0000 - 1.0000i \\ 1.0000 + 0.0000i & 0.0000 - 1.0000i & -1.0000 + 0.0000i \\ -1.0000 - 1.0000i & 1.0000 + 0.0000i & 0.0000 - 1.0000i \end{bmatrix}$$

The matrix has pure imaginary numbers on the main diagonal.

Specify `skewOption` as 'skew' to determine whether the matrix is skew-Hermitian.

```
tf = ishermitian(A, 'skew')
```

tf =

1

The matrix, A, is skew-Hermitian since it is equal to the negation of its complex conjugate transpose,  $-A'$ .

## Definitions

### Hermitian Matrix

- A square matrix, A, is Hermitian if it is equal to its complex conjugate transpose,  $A = A'$ .

In terms of the matrix elements, this means that

$$a_{i,j} = \bar{a}_{j,i} .$$

- The entries on the diagonal of a Hermitian matrix are always real. Since real matrices are unaffected by complex conjugation, a real matrix that is symmetric is also Hermitian. For example, the matrix

$$A = \begin{bmatrix} 1 & 0 & 1 \\ 0 & 2 & 0 \\ 1 & 0 & 1 \end{bmatrix}$$

is both symmetric and Hermitian.

# ishermitian

---

- The eigenvalues of a Hermitian matrix are real.

## Skew-Hermitian Matrix

- A square matrix,  $A$ , is skew-Hermitian if it is equal to the negation of its complex conjugate transpose,  $A = -A'$ .

In terms of the matrix elements, this means that

$$a_{i,j} = -\bar{a}_{j,i} .$$

- The entries on the diagonal of a skew-Hermitian matrix are always pure imaginary or zero. Since real matrices are unaffected by complex conjugation, a real matrix that is skew-symmetric is also skew-Hermitian. For example, the matrix

$$A = \begin{bmatrix} 0 & -1 \\ 1 & 0 \end{bmatrix}$$

is both skew-Hermitian and skew-symmetric.

- The eigenvalues of a skew-Hermitian matrix are purely imaginary or zero.

## See Also

[issymmetric](#) | [isreal](#) | [eig](#) | [transpose](#) | [ctranspose](#)



**Purpose** True for Handle Graphics object handles

**Syntax** `ishghandle(h)`

**Description** `ishghandle(h)` returns an array that contains 1's where the elements of `h` are handles to existing graphic objects and 0's where they are not. Differs from `ishandle` in that Simulink objects handles return false.

**Examples** Create a plot and find the valid handles:

```
x = [1:10];
y = [1:10];
p=plot(x,y);
ishghandle([x y p])
% This returns a 1-by-21 array of values
% with ones at the first, eleventh, and last values,
% if the figure handle is 1.
```

**See Also** `isa` | `ishandle` | `findobj` | `gca` | `gcf` | `set`

**How To** • “Accessing Object Handles”

# ishold

---

**Purpose** Current hold state

**Syntax** `tf = ishold`

**Description** `tf = ishold` returns 1 if hold is on, and 0 if it is off. When hold is on, the current plot and most axis properties are held so that subsequent graphing commands add to the existing graph.

A state of hold on implies that both figure and axes NextPlot properties are set to add.

**See Also** `hold` | `newplot`

**How To** • “Controlling Graphics Output”

**Purpose** Array elements that are infinite

**Syntax** TF = isinf(A)

**Description** TF = isinf(A) returns an array the same size as A containing logical 1 (true) where the elements of A are +Inf or -Inf and logical 0 (false) where they are not. For a complex number z, isinf(z) returns 1 if either the real or imaginary part of z is infinite, and 0 if both the real and imaginary parts are finite or NaN.

For any real A, exactly one of the three quantities isfinite(A), isinf(A), and isnan(A) is equal to one.

**Examples** a = [-2 -1 0 1 2];

```
isinf(1./a)
```

```
ans =
```

```
0 0 1 0 0
```

```
isinf(0./a)
```

```
ans =
```

```
0 0 0 0 0
```

**See Also** isfinite | isnan | is\*

# isinteger

---

**Purpose** Determine if input is integer array

**Syntax** `tf = isinteger(A)`

**Description** `tf = isinteger(A)` returns true if the array A is an integer type and false otherwise.

An integer array is any of the following integer types and any subclasses of those types:

## **MATLAB Integer Types**

|                     |                               |
|---------------------|-------------------------------|
| <code>int8</code>   | 8-bit signed integer array    |
| <code>uint8</code>  | 8-bit unsigned integer array  |
| <code>int16</code>  | 16-bit signed integer array   |
| <code>uint16</code> | 16-bit unsigned integer array |
| <code>int32</code>  | 32-bit signed integer array   |
| <code>uint32</code> | 32-bit unsigned integer array |
| <code>int64</code>  | 64-bit signed integer array   |
| <code>uint64</code> | 64-bit unsigned integer array |

## **Examples**

These examples show the values `isinteger` returns when passed specific types:

```
% uint8 is one of the integer types
isinteger(uint8(1:255))
ans =
 1
% pi returns a double-precision value
isinteger(pi)
ans =
 0
% Constants are double-precision by default
isinteger(3)
```

```
ans =
 0
% isinteger returns a logical value
isinteger(isinteger(uint8(3)))
ans =
 0
```

## See Also

[isa](#) | [isnumeric](#) | [isfloat](#)

# isinterface

---

**Purpose** Determine whether input is COM interface

**Syntax** `tf = h.isinterface`  
`tf = isinterface(h)`

**Description** `tf = h.isinterface` returns logical 1 (true) if handle `h` is a COM interface. Otherwise, returns logical 0 (false).

`tf = isinterface(h)` is an alternate syntax.

COM functions are available on Microsoft Windows systems only.

**Examples** Test an instance of a Microsoft Excel application:

```
h = actxserver('Excel.Application');
h.isinterface
```

MATLAB displays `false`, indicating object `h` is not an interface.

---

Test a workbooks object:

```
w = h.get('workbooks');
w.isinterface
```

MATLAB displays `true`, indicating object `w` is an interface.

**See Also** `iscom` | `interfaces`

**How To** • “Exploring Interfaces”

---

|                    |                                                                                                                                                                                                                                                                                                                         |
|--------------------|-------------------------------------------------------------------------------------------------------------------------------------------------------------------------------------------------------------------------------------------------------------------------------------------------------------------------|
| <b>Purpose</b>     | Determine if input is Java object                                                                                                                                                                                                                                                                                       |
| <b>Syntax</b>      | <code>tf = isjava(A)</code>                                                                                                                                                                                                                                                                                             |
| <b>Description</b> | <code>tf = isjava(A)</code> returns logical 1 (true) if object A is a Java object. Otherwise, it returns logical 0 (false).                                                                                                                                                                                             |
| <b>Examples</b>    | <p><b>Test if java.util.Date Is Java Object</b></p> <p>Create an instance of the Java Date class.</p> <pre>myDate = java.util.Date;<br/>isjava(myDate)</pre> <p>ans =<br/><br/>1</p> <p>myDate is a Java object.</p> <p>However, myDate is not a MATLAB object.</p> <pre>isobject(myDate)</pre> <p>ans =<br/><br/>0</p> |
| <b>See Also</b>    | <code>isobject</code>   <code>javaArray</code>   <code>javaMethod</code>   <code>javaObject</code>   <code>isa</code>   <code>is*</code>                                                                                                                                                                                |

# containers.Map.isKey

---

**Purpose** Determine if containers.Map object contains key

**Syntax** `tf = isKey(mapObj, keySet)`

**Description** `tf = isKey(mapObj, keySet)` looks for the specified keys in `mapObj`, and returns logical true (1) for the keys that it finds, and logical false (0) for those it does not. `keySet` is a scalar key or a cell array of keys.

**Input Arguments**

**mapObj**

Object of class `containers.Map`.

**keySet**

Scalar value, string, or cell array that specifies keys to find in `mapObj`.

**Output Arguments**

**tf**

Array of logical values. If `keySet` is a scalar or a string, `tf` is a scalar. Otherwise, `tf` has the same size and dimensions as `keySet`.

**Examples**

**Find Keys in a Map**

Construct a map that contains rainfall data for several months:

```
months = {'Jan', 'Feb', 'Mar', 'Apr'};
rainfall = [327.2, 368.2, 197.6, 178.4];
mapObj = containers.Map(months, rainfall);
```

Determine if keys Apr, May, and Jun are in the map:

```
keySet = {'Apr', 'May', 'Jun'};
tf = isKey(mapObj, keySet)
```

This code returns 1-by-3 vector `tf`:

```
tf =
 1 0 0
```



## Find a Single Key

Determine if `mapObj` from the previous example contains key `Feb`:

```
keySet = 'Feb';
tf = isKey(mapObj, keySet)
```

This code returns scalar `tf`:

```
tf =
 1
```

## See Also

[containers.Map](#) | [keys](#) | [values](#) | [remove](#)

# iskeyword

---

**Purpose** Determine whether input is MATLAB keyword

**Syntax** `tf = iskeyword('str')`  
`iskeyword str`  
`iskeyword`

**Description** `tf = iskeyword('str')` returns logical 1 (true) if the string `str` is a keyword in the MATLAB language and logical 0 (false) otherwise. MATLAB keywords cannot be used as variable names.

`iskeyword str` uses the MATLAB command format.

`iskeyword` returns a list of all MATLAB keywords.

**Examples** To test if the word `while` is a MATLAB keyword,

```
iskeyword while
ans =
 1
```

To obtain a list of all MATLAB keywords,

```
iskeyword
'break'
'case'
'catch'
'classdef'
'continue'
'else'
'elseif'
'end'
'for'
'function'
'global'
'if'
'otherwise'
'parfor'
'persistent'
```

```
'return'
'spmd'
'switch'
'try'
'while'
```

## See Also

[isvarname](#) | [matlab.lang.makeValidName](#) |  
[matlab.lang.makeUniqueStrings](#) | [is\\*](#)

# isletter

---

**Purpose** Array elements that are alphabetic letters

**Syntax** `tf = isletter('str')`

**Description** `tf = isletter('str')` returns an array the same size as `str` containing logical 1 (true) where the elements of `str` are letters of the alphabet and logical 0 (false) where they are not.

**Examples** Find the letters in character array `s`.

```
s = 'A1,B2,C3';
```

```
isletter(s)
```

```
ans =
```

```
 1 0 0 1 0 0 1 0
```

**See Also**

`ischar` | `isspace` | `isstrprop` | `iscellstr` | `isnumeric` | `char` |  
`strings` | `isa` | `is*`

|                    |                                                                                                                                                                                                                                                                                                                                                                                                                                 |
|--------------------|---------------------------------------------------------------------------------------------------------------------------------------------------------------------------------------------------------------------------------------------------------------------------------------------------------------------------------------------------------------------------------------------------------------------------------|
| <b>Purpose</b>     | Determine if input is logical array                                                                                                                                                                                                                                                                                                                                                                                             |
| <b>Syntax</b>      | <code>tf = islogical(A)</code>                                                                                                                                                                                                                                                                                                                                                                                                  |
| <b>Description</b> | <code>tf = islogical(A)</code> returns true if A is a logical array and false otherwise. <code>islogical</code> also returns true if A is an instance of a class that is derived from the <code>logical</code> class.                                                                                                                                                                                                           |
| <b>Examples</b>    | <p>These examples show the values <code>islogical</code> returns when passed specific types:</p> <pre>% Relational operators return logical values islogical(5&lt;7) ans =      1  % true and false return logical values islogical(true) &amp; islogical(false) ans =      1  % Constants are double-precision by default islogical(1) ans =      0  % logical creates logical values islogical(logical(1)) ans =      1</pre> |
| <b>See Also</b>    | <code>logical</code>   <code>isa</code>   <code>is*</code>                                                                                                                                                                                                                                                                                                                                                                      |
| <b>Concepts</b>    | <ul style="list-style-type: none"><li>“Determine if Arrays Are Logical”</li></ul>                                                                                                                                                                                                                                                                                                                                               |

# ismac

---

**Purpose** Determine if version is for Mac OS X platform

**Syntax** `tf = ismac`

**Description** `tf = ismac` returns logical 1 (true) if the version of MATLAB software is for the Apple Mac OS X platform. Otherwise, it returns logical 0 (false).

**Tips**

- The `isunix` function also determines if version is for Mac OS X platforms.

**See Also** `isunix` | `ispc` | `computer` | `isstudent` | `is*`

**Purpose** Determine whether input is matrix

**Syntax** `ismatrix(V)`

**Description** `ismatrix(V)` returns logical 1 (true) if `size(V)` returns `[m n]` with nonnegative integer values `m` and `n`, and logical 0 (false) otherwise.

**Examples** Create three vectors:

```
V1 = rand(5,1);
V2 = rand(5,1);
V3 = rand(5,1);
```

Concatenate the vectors and check that the result is a matrix. `ismatrix` returns 1:

```
M = cat(2,V1,V2,V3);
ismatrix(M)
ans =
 1
```

**See Also** `iscolumn` | `isrow` | `isscalar` | `isvector`

# ismember

---

**Purpose** Array elements that are members of set array

**Syntax**

```
Lia = ismember(A,B)
Lia = ismember(A,B,'rows')
[Lia,Locb] = ismember(A,B)
[Lia,Locb] = ismember(A,B,'rows')
```

```
[Lia,Locb] = ismember(__ , 'legacy')
```

**Description** `Lia = ismember(A,B)` returns an array containing 1 (true) where the data in `A` is found in `B`. Elsewhere, it returns 0 (false).

- If `A` and `B` are numeric arrays, logical arrays, character arrays, categorical arrays, or cell arrays of strings, then `ismember` returns a logical value for each element of `A`. The output, `Lia`, is an array of the same size as `A`.
- If `A` and `B` are tables, then `ismember` returns a logical value for each row of `A`. The output, `Lia`, is a column vector with the same number of rows as `A`.

`Lia = ismember(A,B,'rows')` treats each row of `A` and each row of `B` as single entities and returns a column vector containing 1 (true) where the rows of `A` are also rows of `B`. Elsewhere, it returns 0 (false).

`A` and `B` must have the same number of columns when you use the 'rows' option. Furthermore, the 'rows' option does not support cell arrays.

`[Lia,Locb] = ismember(A,B)` also returns an array, `Locb`.

- If `A` and `B` are numeric arrays, logical arrays, character arrays, categorical arrays, or cell arrays of strings, then `Locb` contains the lowest index in `B` for each value in `A` that is a member of `B`. The output array, `Locb`, contains 0 wherever `A` is not a member of `B`.



- If A and B are tables, then Locb contains the lowest index in B for each row in A that is also a row in B. The output vector, Locb, contains 0 whenever A is not a row of B.

[Lia,Locb] = ismember(A,B,'rows') also returns a column vector, Locb, containing the lowest index in B for each row in A that is also a row in B. The output vector, Locb, contains 0 wherever A is not a row of B.

[Lia,Locb] = ismember(\_\_,'legacy') preserves the behavior of the ismember function from R2012b and prior releases using any of the input arguments in previous syntaxes.

The 'legacy' option does not support categorical arrays or tables.

## Input Arguments

### A - Query array

numeric array | logical array | character array | categorical array | cell array of strings | table

Query array, specified as a numeric array, logical array, character array, categorical array, cell array of strings, or a table.

A must belong to the same class as B with the following exceptions:

- logical, char, and all numeric classes can combine with double arrays.
- Cell arrays of strings can combine with char arrays.
- Categorical arrays can combine with cell arrays of strings or single strings.

If A and B are both ordinal categorical arrays, they must have the same sets of categories, including their order. If neither A nor B are ordinal, they need not have the same sets of categories, and the comparison is performed using the category names.

If you specify the 'rows' option, A must have the same number of columns as B.

# ismember

---

If A is a table, it must have the same variable names as B. Conversely, the row names do not matter. Two rows that have the same values, but different names, are considered equal.

Furthermore, A can be an object with the following class methods:

- `sort` (or `sortrows` for the 'rows' option)
- `eq`
- `ne`

The object class methods must be consistent with each other. These objects include heterogeneous arrays derived from the same root class.

## **B - Set array**

numeric array | logical array | character array | categorical array | cell array of strings | table

Set array, specified as a numeric array, logical array, character array, categorical array, cell array of strings, or a table.

B must belong to the same class as A with the following exceptions:

- `logical`, `char`, and all numeric classes can combine with double arrays.
- Cell arrays of strings can combine with `char` arrays.
- Categorical arrays can combine with cell arrays of strings or single strings.

If A and B are both ordinal categorical arrays, they must have the same sets of categories, including their order. If neither A nor B are ordinal, they need not have the same sets of categories, and the comparison is performed using the category names.

If you specify the 'rows' option, B must have the same number of columns as A.

If B is a table, it must have the same variable names as A. Conversely, the row names do not matter. Two rows that have the same values, but different names, are considered equal.

Furthermore, B can be an object with the following class methods:

- sort (or sortrows for the 'rows' option)
- eq
- ne

The object class methods must be consistent with each other. These objects include heterogeneous arrays derived from the same root class.

## Output Arguments

### **Lia - Logical index to A**

vector | matrix | N-D array

Logical index to A, returned as a vector, matrix or N-D array containing 1 (true) wherever the values (or rows) in A are members of B. Elsewhere, it returns 0 (false).

Lia is an array of the same size as A, unless you specify the 'rows' flag.

If the 'rows' flag is specified or if A is a table, Lia is a column vector with the same number of rows as A.

### **Locb - Locations in B**

vector | matrix | N-D array

Locations in B, returned as a vector, matrix, or N-D array. If the 'legacy' flag is not specified, Locb contains the lowest indices to the values (or rows) in B that are found in A. Locb contains 0 wherever A is not a member of B.

Locb is an array of the same size as A unless you specify the 'rows' flag.

If the 'rows' flag is specified or if A is a table, Locb is a column vector with the same number of rows as A.

## Examples

### **Values That Are Members of Set**

Define two vectors with values in common.

```
A = [5 3 4 2]; B = [2 4 4 4 6 8];
```

# ismember

---

Determine which elements of A are also in B.

```
Lia = ismember(A,B)
```

```
Lia =
```

```
 0 0 1 1
```

A(3) and A(4) are found in B.

## Table Rows Found in Another Table

Define two tables with rows in common.

```
A = table([1:5]', ['A'; 'B'; 'C'; 'D'; 'E'], logical([0;1;0;1;0]))
B = table([1:2:10]', ['A'; 'C'; 'E'; 'G'; 'I'], logical(zeros(5,1)))
```

```
A =
```

| Var1 | Var2 | Var3  |
|------|------|-------|
| 1    | A    | false |
| 2    | B    | true  |
| 3    | C    | false |
| 4    | D    | true  |
| 5    | E    | false |

```
B =
```

| Var1 | Var2 | Var3  |
|------|------|-------|
| 1    | A    | false |
| 3    | C    | false |
| 5    | E    | false |
| 7    | G    | false |
| 9    | I    | false |

Determine which rows of A are also in B.

```
Lia = ismember(A,B)
```

```
Lia =
```

```

 1
 0
 1
 0
 1

```

A(1,:), A(3,:), and A(5,:) are found in B.

### Members of Set and Indices to Values

Define two vectors with values in common.

```
A = [5 3 4 2]; B = [2 4 4 4 6 8];
```

Determine which elements of A are also in B as well as their corresponding locations in B.

```
[Lia,Locb] = ismember(A,B)
```

```
Lia =
```

```

 0 0 1 1

```

```
Locb =
```

```

 0 0 2 1

```

The lowest index to A(3) is B(2).

A(4) is found in B(1).

### Rows of Another Table and Their Location

Define a table, A, of gender, age, and height for five people.

# ismember

---

```
A = table(['M';'M';'F';'M';'F'],[27;52;31;46;35],[74;68;64;61;64],...
'VariableNames',{'Gender' 'Age' 'Height'},...
'RowNames',{'Ted' 'Fred' 'Betty' 'Bob' 'Judy'})
```

A =

|       | Gender | Age | Height |
|-------|--------|-----|--------|
|       | -----  | --- | -----  |
| Ted   | M      | 27  | 74     |
| Fred  | M      | 52  | 68     |
| Betty | F      | 31  | 64     |
| Bob   | M      | 46  | 61     |
| Judy  | F      | 35  | 64     |

Define a table, B, with rows in common with A.

```
B = table(['M';'F';'F';'F'],[47;31;35;23],[68;64;62;58],...
'VariableNames',{'Gender' 'Age' 'Height'},...
'RowNames',{'Joe' 'Meg' 'Beth' 'Amy'})
```

B =

|      | Gender | Age | Height |
|------|--------|-----|--------|
|      | -----  | --- | -----  |
| Meg  | F      | 31  | 64     |
| Joe  | M      | 47  | 68     |
| Beth | F      | 35  | 62     |
| Amy  | F      | 23  | 58     |

Determine which rows of A are also in B, as well as their corresponding locations in B.

```
[Lia,Locb] = ismember(A,B)
```

Lia =

```
0
0
```

```
1
0
0
```

```
Locb =
```

```
0
0
2
0
0
```

Two rows that have the same values, but different names, are considered equal. The same data for Betty is found in `B(2,:)`, which corresponds to Meg.

### Rows That Belong to a Set

Define two matrices with a row in common.

```
A = [1 3 5 6; 2 4 6 8];
B = [2 4 6 8; 1 3 5 7; 2 4 6 8];
```

Determine which rows of `A` are also in `B` as well as their corresponding locations in `B`.

```
[Lia, Locb] = ismember(A,B, 'rows')
```

```
Lia =
```

```
0
1
```

```
Locb =
```

```
0
```

# ismember

---

1

The lowest index to A(2,:) is B(1,:).

## Members of Set Containing NaN Values

Define two vectors containing NaN.

```
A = [5 NaN NaN]; B = [5 NaN NaN];
```

Determine which elements of A are also in B as well as their corresponding locations in B.

```
[Lia,Locb] = ismember(A,B)
```

```
Lia =
```

```
1 0 0
```

```
Locb =
```

```
1 0 0
```

ismember treats NaN values as distinct.

## Cell Array of Strings with Trailing White Space

Create a cell array of strings, A.

```
A = {'dog','cat','fish','horse'};
```

Create a cell array of strings, B, where some of the strings have trailing white space.

```
B = {'dog ','cat','fish ','horse'};
```

Determine which strings of A can be found in B.

```
[Lia,Locb] = ismember(A,B)
```



```
Lia =

 0 1 0 1
```

```
Locb =

 0 2 0 4
```

`ismember` treats trailing white space in cell arrays of strings as distinct characters.

## Members of Char and Cell Array of Strings

Create a character array, A.

```
A = ['cat'; 'dog'; 'fox'; 'pig'];
```

Create a cell array of strings, B.

```
B = {'dog', 'cat', 'fish', 'horse'};
```

Determine which strings of A can be found in B.

```
[Lia,Locb] = ismember(A,B)
```

```
Lia =

 1
 1
 0
 0
```

```
Locb =

 2
 1
 0
```

# ismember

---

0

## Preserve Legacy Behavior of ismember

Use the 'legacy' flag to preserve the behavior of `ismember` from R2012b and prior releases in your code.

Find the members of B with the current behavior.

```
A = [5 3 4 2]; B = [2 4 4 4 6 8];
[Lia1,Locb1] = ismember(A,B)
```

```
Lia1 =

 0 0 1 1
```

```
Locb1 =

 0 0 2 1
```

Find the members of B, and preserve the legacy behavior.

```
[Lia2,Locb2] = ismember(A,B,'legacy')
```

```
Lia2 =

 0 0 1 1
```

```
Locb2 =

 0 0 4 1
```

## Tips

- To find the rows from table A that are found in B with respect to a subset of variables, you can use column subscripting. For example, you can use `ismember(A(:,vars),B(:,vars))`, where `vars` is a positive integer, a vector of positive integers, a variable name, a cell array of variable names, or a logical vector.

**See Also**      unique | intersect | union | issorted | setdiff | setxor | sort

# ismethod

---

**Purpose** Determine if method of object

**Syntax** `tf = ismethod(h, 'methodName')`

**Description** `tf = ismethod(h, 'methodName')` returns logical 1 (true) if the specified `methodName` is a public method of object `obj`. Otherwise, returns logical 0 (false).

**Examples** Determine if objects support equality testing:

```
if ismethod(obj1,'eq') && ismethod(obj2,'eq')
 tf = obj1 == obj2;
end
```

**See Also** `methods` | `isprop` | `isobject` | `class`

**Tutorials**

- “Methods”

**Purpose** Determine whether input is COM object method

**Syntax**

```
tf = h.ismethod('methodname')
tf = ismethod(h,'methodname')
```

**Description** `tf = h.ismethod('methodname')` returns logical 1 (true) if the specified `methodname` is a method you can call on COM object `h`. Otherwise, returns logical 0 (false).

`tf = ismethod(h,'methodname')` is an alternate syntax.

COM functions are available on Microsoft Windows systems only.

**Examples** Test members of an instance of a Microsoft Excel application:

```
h = actxserver ('Excel.Application');
ismethod(h, 'SaveWorkspace')
```

MATLAB returns true, `SaveWorkspace` is a method.

---

Try the same test on `UsableWidth`:

```
ismethod(h, 'UsableWidth')
```

MATLAB returns false, `UsableWidth` is not a method; it is a property.

**See Also** `methods` | `methodsview` | `isprop` | `isevent` | `isobject` | `class`

**How To**

- “Exploring Methods”

# ismissing

---

**Purpose** Find table elements with missing values

**Syntax** TF = ismissing(A)  
TF = ismissing(A,id)

**Description** TF = ismissing(A) returns a logical array, TF, that indicates which elements in the table A contain a missing value. The size of TF is the same as the size of A.

Indicators for missing data depend on the data type:

- NaN for numeric arrays
- <undefined> for categorical arrays
- empty string, { ' ' }, for cell arrays of strings
- blank string, [ ' ' ], for character arrays

ismissing ignores other data types.

TF = ismissing(A,id) treats the values in id as missing value indicators. You must include NaN (for floating-point variables), the empty string (for variables that are cell arrays of strings or character arrays), or the string '<undefined>' (for categorical variables) to have ismissing recognize them as missing value indicators.

## Input Arguments

### A - Input table

table

Input table, specified as a table.

### id - Missing value indicators

numeric vector | string | cell array containing numeric values and strings

Missing value indicators, specified as a numeric vector, string, or cell array containing numeric values and strings. Use strings to identify categories in categorical variables that you want to treat as missing values.

You must include NaN (for floating-point variables), the empty string (for variables that are cell arrays of strings or character arrays), or the string '<undefined>' (for categorical variables) to have `ismissing` recognize them as missing value indicators.

**Example:** `TF = ismissing(A, -99)` recognizes only -99 as a missing value.

## Data Types

double | char | cell

## Examples

### Missing Values in Table with Various Data Types

Create a table with variables of different data types where each contains a missing value.

```
dblVar = [NaN;3;5;7;9];
singleVar = single([1;NaN;5;7;9]);
cellstrVar = {'one';'three';'';'seven';'nine'};
charVar = ['A';'C';'E';' ';'I'];
categoryVar = categorical({'red';'yellow';'blue';'violet';''});

A = table(dblVar,singleVar,cellstrVar,charVar,categoryVar)
```

A =

| dblVar | singleVar | cellstrVar | charVar | categoryVar |
|--------|-----------|------------|---------|-------------|
| NaN    | 1         | 'one'      | A       | red         |
| 3      | NaN       | 'three'    | C       | yellow      |
| 5      | 5         | ''         | E       | blue        |
| 7      | 7         | 'seven'    |         | violet      |
| 9      | 9         | 'nine'     | I       | <undefined> |

Find the table elements with missing values.

```
TF = ismissing(A)
```

# ismissing

---

TF =

```
 1 0 0 0 0
 0 1 0 0 0
 0 0 1 0 0
 0 0 0 1 0
 0 0 0 0 1
```

The size of TF is the same as the size of A.

## Specify Indicators for Missing Values in Table

Create a table where 'NA', '' -99, NaN, and Inf represent missing values.

```
dblVar = [NaN;3;Inf;7;9];
int8Var = int8([1;3;5;7;-99]);
cellstrVar = {'one';'three';'';'NA';'nine'};
charVar = ['A';'C';'E';' ';'I'];
```

```
A = table(dblVar,int8Var,cellstrVar,charVar)
```

A =

| dblVar | int8Var | cellstrVar | charVar |
|--------|---------|------------|---------|
| NaN    | 1       | 'one'      | A       |
| 3      | 3       | 'three'    | C       |
| Inf    | 5       | ''         | E       |
| 7      | 7       | 'NA'       |         |
| 9      | -99     | 'nine'     | I       |

Find the missing values in the table A.

```
id = {'NA' '' -99 NaN Inf};
TF = ismissing(A,id)
```

TF =



```

1 0 0 0
0 0 0 0
1 0 1 0
0 0 1 1
0 1 0 0

```

`ismissing` recognizes data in the each variable of the table, `A` as missing values. `ismissing` ignores trailing white space in character arrays. Therefore, since the empty string, `''`, is specified as a missing value indicator, `ismissing` identifies the empty string in the cell arrays of strings, `A.cellstrVar`, as well as the blank space in character array, `A.charVar` as missing values.

## Algorithms

`ismissing` treats leading and trailing white space differently for cell arrays of strings, character arrays, and categorical arrays.

- For cell arrays of strings, `ismissing` does not ignore white space. All strings must match exactly.
- For character arrays, `ismissing` ignores trailing white space. Therefore, when you specify the empty string, `''`, as a missing value indicator, `ismissing` identifies the empty string in cell arrays of strings, `''`, and the blank space in character arrays, `' '`, as missing values.
- For categorical arrays, `ismissing` ignores leading and trailing white space.

## Tips

- You can use `A(~any(TF,2),:)` to return only complete rows from `A` and `A(:,~any(TF,1))` to return only the variables from `A` with no missing values.
- Integer variables cannot store NaN; therefore, you must use a special integer value (otherwise unused) to indicate missing integer data. For example, `-99`.

## See Also

`standardizeMissing` | `isnan` | `isempty` | `isundefined` | `table`

# isnan

---

**Purpose** Array elements that are NaN

**Syntax** TF = isnan(A)

**Description** TF = isnan(A) returns an array the same size as A containing logical 1 (true) where the elements of A are NaNs and logical 0 (false) where they are not. For a complex number z, isnan(z) returns 1 if either the real or imaginary part of z is NaN, and 0 if both the real and imaginary parts are finite or Inf.

For any real A, exactly one of the three quantities isfinite(A), isinf(A), and isnan(A) is equal to one.

**Examples**

```
A = [-2 -1 0 1 2];

isnan(1./A)
ans =
 0 0 0 0 0

isnan(0./A)
ans =
 0 0 1 0 0
```

**See Also** isfinite | isinf | is\* | nan

**Purpose** Determine if input is numeric array

**Syntax** `tf = isnumeric(A)`

**Description** `tf = isnumeric(A)` returns true if `A` is a numeric array and false otherwise.

A numeric array is any of the following numeric types and any subclasses of those types:

### **MATLAB Numeric Types**

|                     |                                       |
|---------------------|---------------------------------------|
| <code>single</code> | Single-precision floating-point array |
| <code>double</code> | Double-precision floating-point array |
| <code>int8</code>   | 8-bit signed integer array            |
| <code>uint8</code>  | 8-bit unsigned integer array          |
| <code>int16</code>  | 16-bit signed integer array           |
| <code>uint16</code> | 16-bit unsigned integer array         |
| <code>int32</code>  | 32-bit signed integer array           |
| <code>uint32</code> | 32-bit unsigned integer array         |
| <code>int64</code>  | 64-bit signed integer array           |
| <code>uint64</code> | 64-bit unsigned integer array         |

**Examples** These examples show the values `isnumeric` returns when passed specific types:

```
% pi returns a numeric value
isnumeric(pi)
ans =
 1
% Complex numbers are numeric
isnumeric(3+7i)
ans =
```

# isnumeric

---

```
 1
% Integers are numeric
isnumeric(uint8(1:255))
ans =
 1
% isnumeric returns a logical value
isnumeric(isnumeric(pi))
ans =
 0
```

## See Also

[isfloat](#) | [isinteger](#) | [isnan](#) | [isreal](#) | [isprime](#) | [isfinite](#) | [isinf](#)  
| [isa](#) | [is\\*](#)

**Purpose** Determine if input is MATLAB object

**Syntax** `tf = isobject(A)`

**Description** `tf = isobject(A)` returns true if A is an object of a MATLAB class. Otherwise, it returns false.

Handle Graphics objects return false. Use `ishandle` to test for Handle Graphics objects.

Instances of MATLAB fundamental classes return false. Use `isa` to test for any of these types. See “Fundamental MATLAB Classes” for more on these classes.

**Examples** These examples show the values `isobject` returns when passed specific types:

Define the following MATLAB class:

```
classdef button < handle
 properties
 UiHandle
 end
 methods
 function obj = button(pos)
 obj.UiHandle = uicontrol('Position',pos,...
 'Style','pushbutton');
 end
 end
end
```

Determine which objects are MATLAB objects. For example:

```
h = button([20 20 60 60]);
isobject(h)
ans =
 1
isobject(h.UiHandle)
```

# isobject

---

```
ans =
 0
```

---

Use `isjava` to test for Java objects in MATLAB, where it returns `false` for MATLAB objects:

```
isjava(h)
ans =
 0
```

---

Create an object that is a MATLAB numeric type:

```
a = pi;
isa(a, 'double')
ans =
 1
isobject(a)
ans =
 0
```

## See Also

`class` | `isa` | `is*`

## Tutorials

- “Class Syntax Fundamentals”

**Purpose** Compute isosurface end-cap geometry

**Syntax**

```
fvc = isocaps(X,Y,Z,V,isovalue)
fvc = isocaps(V,isovalue)
fvc = isocaps(...,'enclose')
fvc = isocaps(...,'whichplane')
[f,v,c] = isocaps(...)
isocaps(...)
```

**Description** `fvc = isocaps(X,Y,Z,V,isovalue)` computes isosurface end-cap geometry for the volume data `V` at isosurface value `isovalue`. The arrays `X`, `Y`, and `Z` define the coordinates for the volume `V`.

The struct `fvc` contains the face, vertex, and color data for the end-caps and can be passed directly to the `patch` command.

`fvc = isocaps(V,isovalue)` assumes the arrays `X`, `Y`, and `Z` are defined as `[X,Y,Z] = meshgrid(1:n,1:m,1:p)` where `[m,n,p] = size(V)`.

`fvc = isocaps(...,'enclose')` specifies whether the end-caps enclose data values above or below the value specified in `isovalue`. The string `enclose` can be either `above` (default) or `below`.

`fvc = isocaps(...,'whichplane')` specifies on which planes to draw the end-caps. Possible values for `whichplane` are `all` (default), `xmin`, `xmax`, `ymin`, `ymax`, `zmin`, or `zmax`.

`[f,v,c] = isocaps(...)` returns the face, vertex, and color data for the end-caps in three arrays instead of the struct `fvc`.

`isocaps(...)` without output arguments draws a patch with the computed faces, vertices, and colors.

**Examples** This example uses a data set that is a collection of MRI slices of a human skull. It illustrates the use of `isocaps` to draw the end-caps on this cutaway volume.

The red isosurface shows the outline of the volume (skull) and the end-caps show what is inside of the volume.

The patch created from the end-cap data (p2) uses interpolated face coloring, which means the gray colormap and the light sources determine how it is colored. The isosurface patch (p1) used a flat red face color, which is affected by the lights, but does not use the colormap.

```
load mri
D = squeeze(D);
D(:,1:60,:) = [];
p1 = patch(isosurface(D, 5), 'FaceColor', 'red', ...
 'EdgeColor', 'none');
p2 = patch(isocaps(D, 5), 'FaceColor', 'interp', ...
 'EdgeColor', 'none');
view(3); axis tight; daspect([1,1,.4])
colormap(gray(100))
camlight left; camlight; lighting gouraud
isonormals(D,p1)
```

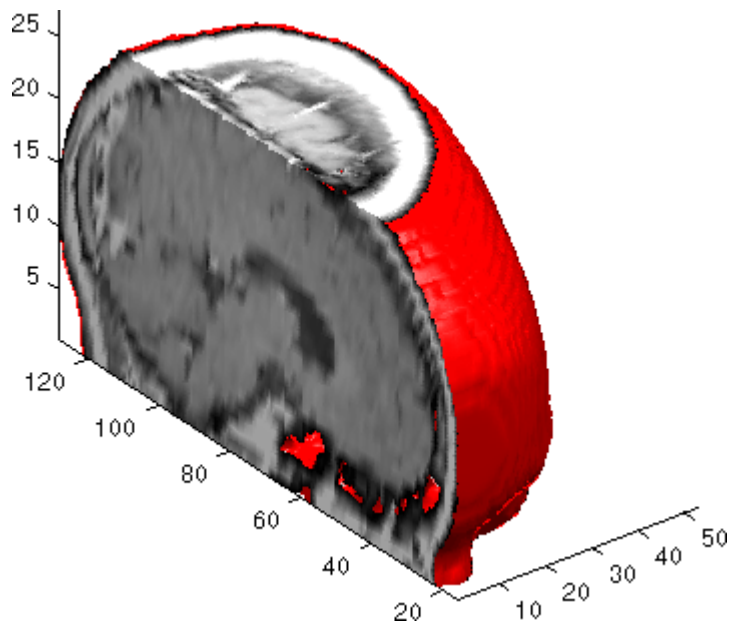



**See Also**

`isosurface` | `isonormals` | `smooth3` | `subvolume` | `reducevolume`  
| `reducepatch`

**How To**

- “Isocaps Add Context to Visualizations”

# isocolors

---

**Purpose** Calculate isosurface and patch colors

**Syntax**

```
nc = isocolors(X,Y,Z,C,vertices)
nc = isocolors(X,Y,Z,R,G,B,vertices)
nc = isocolors(C,vertices)
nc = isocolors(R,G,B,vertices)
nc = isocolors(...,PatchHandle)
isocolors(...,PatchHandle)
```

**Description** `nc = isocolors(X,Y,Z,C,vertices)` computes the colors of isosurface (patch object) `vertices` using color values `C`. Arrays `X`, `Y`, `Z` define the coordinates for the color data in `C` and must be monotonic vectors that represent a Cartesian, axis-aligned grid (as if produced by `meshgrid`). The colors are returned in `nc`. `C` must be 3-D (index colors).

`nc = isocolors(X,Y,Z,R,G,B,vertices)` uses `R`, `G`, `B` as the red, green, and blue color arrays (true color).

`nc = isocolors(C,vertices)`, and `nc = isocolors(R,G,B,vertices)` assume `X`, `Y`, and `Z` are determined by the expression

```
[X Y Z] = meshgrid(1:n,1:m,1:p)
```

where `[m n p] = size(C)`.

`nc = isocolors(...,PatchHandle)` uses the vertices from the patch identified by `PatchHandle`.

`isocolors(...,PatchHandle)` sets the `FaceVertexCData` property of the patch specified by `PatchHandle` to the computed colors.

## Examples **Indexed Color Data**

This example displays an isosurface and colors it with random data using indexed color. (See “Interpolating in Indexed Color Versus Truicolor” for information on how patch objects interpret color data.)

```
[x y z] = meshgrid(1:20,1:20,1:20);
```

```

data = sqrt(x.^2 + y.^2 + z.^2);
cdata = smooth3(rand(size(data)), 'box', 7);
p = patch(isosurface(x,y,z,data,10));
isonormals(x,y,z,data,p);
isocolors(x,y,z,cdata,p);
set(p, 'FaceColor', 'interp', 'EdgeColor', 'none')
view(150,30); daspect([1 1 1]); axis tight
camlight; lighting phong;

```

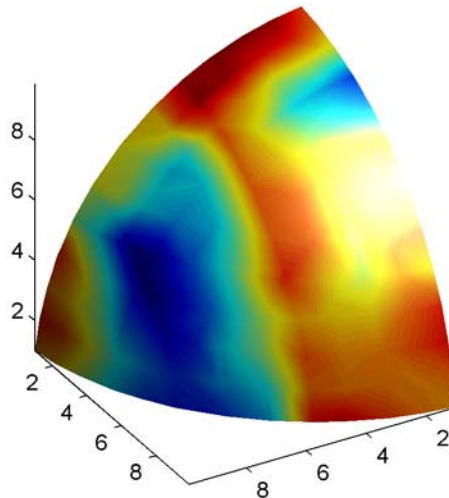

### True Color Data

This example displays an isosurface and colors it with true color (RGB) data.

```

[x y z] = meshgrid(1:20,1:20,1:20);
data = sqrt(x.^2 + y.^2 + z.^2);
p = patch(isosurface(x,y,z,data,20));
isonormals(x,y,z,data,p);
[r g b] = meshgrid(20:-1:1,1:20,1:20);

```

# isocolors

---

```
isocolors(x,y,z,r/20,g/20,b/20,p);
set(p,'FaceColor','interp','EdgeColor','none')
view(150,30); daspect([1 1 1]);
camlight; lighting phong;
```

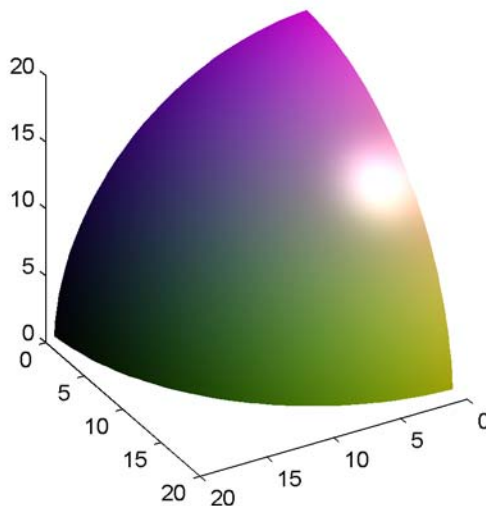

## Modified True Color Data

This example uses `isocolors` to calculate the true color data using the isosurface's (patch object's) vertices, but then returns the color data in a variable (`c`) in order to modify the values. It then explicitly sets the isosurface's `FaceVertexCData` to the new data (`1-c`).

```
[x y z] = meshgrid(1:20,1:20,1:20);
data = sqrt(x.^2 + y.^2 + z.^2);
p = patch(isosurface(data,20));
isonormals(data,p);
[r g b] = meshgrid(20:-1:1,1:20,1:20);
c = isocolors(r/20,g/20,b/20,p);
set(p,'FaceVertexCData',1-c)
```

```
set(p,'FaceColor','interp','EdgeColor','none')
view(150,30); daspect([1 1 1]);
camlight; lighting phong;
```

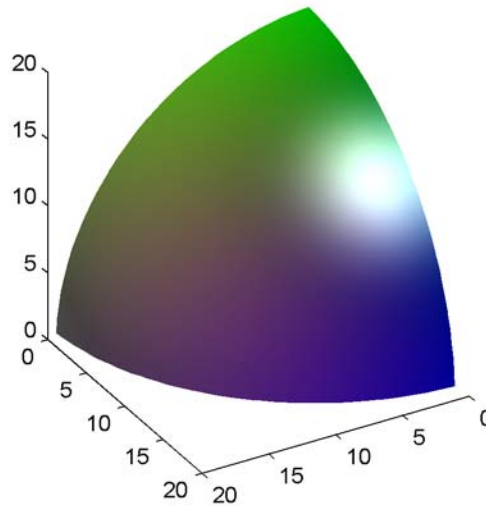

## See Also

[isosurface](#) | [isocaps](#) | [smooth3](#) | [subvolume](#) | [reducevolume](#) | [reducephatch](#) | [isonormals](#)

# isonormals

---

**Purpose** Compute normals of isosurface vertices

**Syntax**

```
n = isonormals(X,Y,Z,V,vertices)
n = isonormals(V,vertices)
n = isonormals(V,p) and n = isonormals(X,Y,Z,V,p)
n = isonormals(...,'negate')
isonormals(V,p) and isonormals(X,Y,Z,V,p)
```

**Description** `n = isonormals(X,Y,Z,V,vertices)` computes the normals of the isosurface vertices from the vertex list, `vertices`, using the gradient of the data `V`. The arrays `X`, `Y`, and `Z` define the coordinates for the volume `V`. The computed normals are returned in `n`.

`n = isonormals(V,vertices)` assumes the arrays `X`, `Y`, and `Z` are defined as `[X,Y,Z] = meshgrid(1:n,1:m,1:p)` where `[m,n,p] = size(V)`.

`n = isonormals(V,p)` and `n = isonormals(X,Y,Z,V,p)` compute normals from the vertices of the patch identified by the handle `p`.

`n = isonormals(...,'negate')` negates (reverses the direction of) the normals.

`isonormals(V,p)` and `isonormals(X,Y,Z,V,p)` set the `VertexNormals` property of the patch identified by the handle `p` to the computed normals rather than returning the values.

**Examples** This example compares the effect of different surface normals on the visual appearance of lit isosurfaces. In one case, the triangles used to draw the isosurface define the normals. In the other, the `isonormals` function uses the volume data to calculate the vertex normals based on the gradient of the data points. The latter approach generally produces a smoother-appearing isosurface.

Define a 3-D array of volume data (`cat`, `interp3`):

```
data = cat(3, [0 .2 0; 0 .3 0; 0 0 0], ...
 [.1 .2 0; 0 1 0; .2 .7 0], ...
 [0 .4 .2; .2 .4 0;.1 .1 0]);
```

```
data = interp3(data,3,'cubic');
```

Draw an isosurface from the volume data and add lights. This isosurface uses triangle normals (patch, isosurface, view, daspect, axis, camlight, lighting, title):

```
subplot(1,2,1)
p1 = patch(isosurface(data,.5),...
'FaceColor','red','EdgeColor','none');
view(3); daspect([1,1,1]); axis tight
camlight; camlight(-80,-10); lighting phong;
title('Triangle Normals')
```

Draw the same lit isosurface using normals calculated from the volume data:

```
subplot(1,2,2)
p2 = patch(isosurface(data,.5),...
'FaceColor','red','EdgeColor','none');
isonormals(data,p2)
view(3); daspect([1 1 1]); axis tight
camlight; camlight(-80,-10); lighting phong;
title('Data Normals')
```

These isosurfaces illustrate the difference between triangle and data normals:

# isonormals

---

Triangle Normals

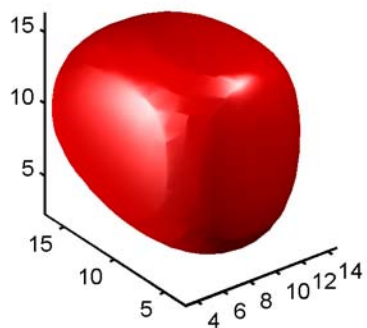

Data Normals

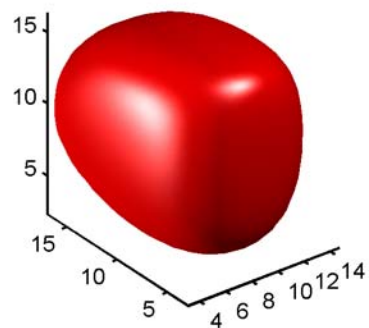

## See Also

`interp3` | `isosurface` | `isocaps` | `smooth3` | `subvolume` |  
`reducevolume` | `reducepatch`



|                        |                                                                                                                                                                                                                                                                                                                                                                                                                                                                                                                     |
|------------------------|---------------------------------------------------------------------------------------------------------------------------------------------------------------------------------------------------------------------------------------------------------------------------------------------------------------------------------------------------------------------------------------------------------------------------------------------------------------------------------------------------------------------|
| <b>Purpose</b>         | Determine whether input is ordinal categorical array                                                                                                                                                                                                                                                                                                                                                                                                                                                                |
| <b>Syntax</b>          | <code>tf = isordinal(A)</code>                                                                                                                                                                                                                                                                                                                                                                                                                                                                                      |
| <b>Description</b>     | <p><code>tf = isordinal(A)</code> returns logical 1 (true) if A is an ordinal categorical array. Otherwise, <code>isordinal</code> returns logical 0 (false).</p> <p>If a categorical array is ordinal, you can use relational operations for inequality comparisons, such as <code>greater</code> and <code>less than</code>, in addition to tests for equality.</p>                                                                                                                                               |
| <b>Input Arguments</b> | <p><b>A - Categorical array</b><br/>vector   matrix   multidimensional array</p> <p>Categorical array, specified as a vector, matrix, or multidimensional array.</p>                                                                                                                                                                                                                                                                                                                                                |
| <b>Examples</b>        | <p><b>Determine Whether Categorical Array Is Ordinal</b></p> <p>Create a categorical array containing the sizes of 10 objects. Use the names <code>small</code>, <code>medium</code>, and <code>large</code> for the values 'S', 'M', and 'L'.</p> <pre>A = categorical({'M';'L';'S';'S';'M';'L';'M';'L';'M';'S'},...                {'S','M','L'},{'small','medium','large'})</pre> <p>A =</p> <pre>     medium     large     small     small     medium     large     medium     large     medium     small</pre> |

# isordinal

---

Determine if the categories of A have a mathematical ordering.

```
isordinal(A)
```

```
ans =
```

```
0
```

A is not ordinal. You must use the 'Ordinal', true name-value pair argument in the function `categorical` to create an ordinal categorical array.

## Tips

- To convert a categorical array, A, from nonordinal to ordinal, use `A = categorical(A, 'Ordinal', true)`.
- To convert a categorical array, A, from ordinal to nonordinal, use `A = categorical(A, 'Ordinal', false)`.

## See Also

`categorical` | `categories`

## Concepts

- “Ordinal Categorical Arrays”

**Purpose** Extract isosurface data from volume data

**Syntax**

```
fv = isosurface(X,Y,Z,V,isovalue)
fv = isosurface(V,isovalue)
fvc = isosurface(...,colors)
fv = isosurface(...,'noshare')
fv = isosurface(...,'verbose')
[f,v] = isosurface(...)
[f,v,c] = isosurface(...)
isosurface(...)
```

**Description** `fv = isosurface(X,Y,Z,V,isovalue)` computes isosurface data from the volume data `V` at the isosurface value specified in `isovalue`. That is, the isosurface connects points that have the specified value much the way contour lines connect points of equal elevation.

The arrays `X`, `Y`, and `Z` represent a Cartesian, axis-aligned grid. `V` contains the corresponding values at these grid points. The coordinate arrays (`X`, `Y`, and `Z`) must be monotonic and conform to the format produced by `meshgrid`. `V` must be a 3D volume array of the same size as `X`, `Y`, and `Z`.

The struct `fv` contains the faces and vertices of the isosurface, which you can pass directly to the `patch` command.

`fv = isosurface(V,isovalue)` assumes the arrays `X`, `Y`, and `Z` are defined as `[X,Y,Z] = meshgrid(1:n,1:m,1:p)` where `[m,n,p] = size(V)`.

`fvc = isosurface(...,colors)` interpolates the array `colors` onto the scalar field and returns the interpolated values in the `facevertexcdata` field of the `fvc` structure. The size of the `colors` array must be the same as `V`. The `colors` argument enables you to control the color mapping of the isosurface with data different from that used to calculate the isosurface (e.g., temperature data superimposed on a wind current isosurface).

# isosurface

---

`fv = isosurface(..., 'noshare')` does not create shared vertices. This is faster, but produces a larger set of vertices.

`fv = isosurface(..., 'verbose')` prints progress messages to the command window as the computation progresses.

`[f,v] = isosurface(...)` or `[f,v,c] = isosurface(...)` returns the faces and vertices (and `faceVertexcCData`) in separate arrays instead of a struct.

`isosurface(...)` with no output arguments, creates a patch in the current axes with the computed faces and vertices. If no current axes exists, a new axes is created with a 3-D view and appropriate lighting.

## Special Case Behavior – isosurface Called with No Output Arguments

If there is no current axes and you call `isosurface` with without assigning output arguments, MATLAB creates a new axes, sets it to a 3-D view, and adds lighting to the isosurface graph.

## Tips

You can pass the `fv` structure created by `isosurface` directly to the `patch` command, but you cannot pass the individual faces and vertices arrays (`f`, `v`) to `patch` without specifying property names. For example,

```
patch(isosurface(X,Y,Z,V,isovalue))
```

or

```
[f,v] = isosurface(X,Y,Z,V,isovalue);
patch('Faces',f,'Vertices',v)
```

## Examples

### Example 1

This example uses the flow data set, which represents the speed profile of a submerged jet within an infinite tank (type `help flow` for more information). The isosurface is drawn at the data value of -3. The statements that follow the `patch` command prepare the isosurface for lighting by

- Recalculating the isosurface normals based on the volume data (`isonormals`)
- Setting the face and edge color (`set`, `FaceColor`, `EdgeColor`)
- Specifying the view (`daspect`, `view`)
- Adding lights (`camlight`, `lighting`)

```
[x,y,z,v] = flow;
p = patch(isosurface(x,y,z,v,-3));
isonormals(x,y,z,v,p)
set(p,'FaceColor','red','EdgeColor','none');
daspect([1,1,1])
view(3); axis tight
camlight
lighting gouraud
```

# isosurface

---

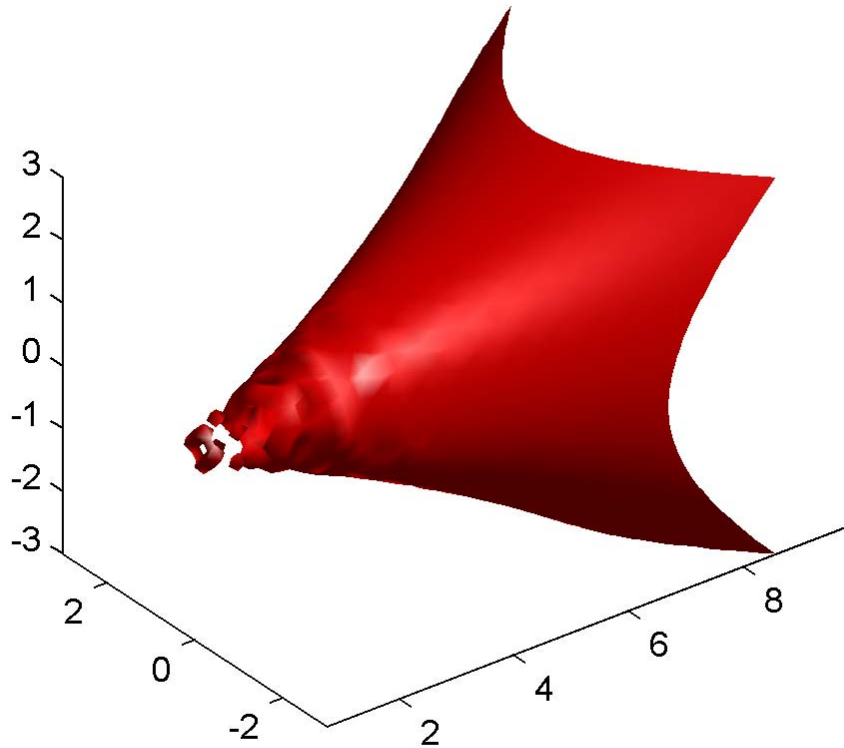

## Example 2

Visualize the same flow data as above, but color-code the surface to indicate magnitude along the X-axis. Use a sixth argument to `isosurface`, which provides a means to overlay another data set by coloring the resulting isosurface. The `colors` variable is a vector containing a scalar value for each vertex in the isosurface, to be portrayed with the current color map. In this case, it is one of the

variables that define the surface, but it could be entirely independent. You can apply a different color scheme by changing the current figure color map.

```
[x,y,z,v] = flow;
[faces,verts,colors] = isosurface(x,y,z,v,-3,x);
patch('Vertices', verts, 'Faces', faces, ...
 'FaceVertexCData', colors, ...
 'FaceColor', 'interp', ...
 'edgecolor', 'interp');
view(30,-15);
axis vis3d;
colormap copper
```

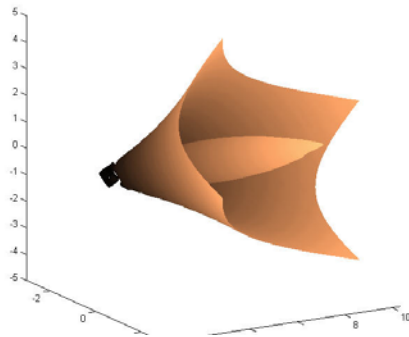

## See Also

[isonormals](#) | [shrinkfaces](#) | [smooth3](#) | [subvolume](#)

## How To

- “Connecting Equal Values with Isosurfaces”

# ispc

---

**Purpose** Determine if version is for Windows (PC) platform

**Syntax** `tf = ispc`

**Description** `tf = ispc` returns logical 1 (true) if the version of MATLAB software is for the Microsoft Windows platform. Otherwise, it returns logical 0 (false).

**See Also** `isunix` | `ismac` | `computer` | `isstudent` | `is*`



---

|                    |                                                                                                                                                                                                                                                                                                                                                                                                                                                                     |
|--------------------|---------------------------------------------------------------------------------------------------------------------------------------------------------------------------------------------------------------------------------------------------------------------------------------------------------------------------------------------------------------------------------------------------------------------------------------------------------------------|
| <b>Purpose</b>     | Test for existence of preference                                                                                                                                                                                                                                                                                                                                                                                                                                    |
| <b>Syntax</b>      | <pre>ispref('group','pref') ispref('group') ispref('group',{'pref1','pref2',... 'prefn'})</pre>                                                                                                                                                                                                                                                                                                                                                                     |
| <b>Description</b> | <p><code>ispref('group','pref')</code> returns 1 if the preference specified by <code>group</code> and <code>pref</code> exists, and 0 otherwise.</p> <p><code>ispref('group')</code> returns 1 if the <code>GROUP</code> exists, and 0 otherwise.</p> <p><code>ispref('group',{'pref1','pref2',... 'prefn'})</code> returns a logical array the same length as the cell array of preference names, containing 1 where each preference exists, and 0 elsewhere.</p> |
| <b>Examples</b>    | <pre>addpref('mytoolbox','version','1.0') ispref('mytoolbox','version')  ans =      1</pre>                                                                                                                                                                                                                                                                                                                                                                         |
| <b>See Also</b>    | <code>addpref</code>   <code>getpref</code>   <code>rmpref</code>   <code>setpref</code>   <code>uigetpref</code>   <code>uisetpref</code>                                                                                                                                                                                                                                                                                                                          |

# isprime

---

**Purpose** Determine which array elements are prime

**Syntax** `TF = isprime(X)`

**Description** `TF = isprime(X)` returns a logical array the same size as `X`. The value at `TF(i)` is true when `X(i)` is a prime number. Otherwise, the value is false.

**Input Arguments** **X - Input values**

scalar, vector, or array of real, nonnegative integer values

Input values, specified as a scalar, vector, or array of real, nonnegative integer values.

**Example:** 17

**Example:** `[1 2 3 4]`

**Example:** `int16([127 255 4095])`

**Data Types**

`single` | `double` | `int8` | `int16` | `int32` | `int64` | `uint8` | `uint16` | `uint32` | `uint64`

**Examples** **Determine if Double Integer Values Are Prime**

```
tf = isprime([2 3 0 6 10])
```

```
tf =
```

```
 1 1 0 0 0
```

2 and 3 are prime, but 0, 6, and 10 are not.

**Determine if Unsigned Integer Values Are Prime**

```
x = uint16([333 71 99]);
```

```
tf = isprime(x)
```

```
tf =
```

```
0 1 0
```

71 is prime, but 333 and 99 are not.

## See Also

[is\\*](#) | [primes](#)

# isprop

---

**Purpose** Determine if property of object

**Syntax** `tf = isprop(obj, 'PropertyName')`

**Description** `tf = isprop(obj, 'PropertyName')` returns true if the specified `PropertyName` is a property of object `obj`. Otherwise, `isprop` returns logical false.

If `obj` is an array, `isprop` returns a logical array the same size as `obj`. Each true element of `tf` corresponds to an element of `obj` that has the property, `PropertyName`.

---

**Note** If `obj` is an empty object or an array of empty objects, `isprop` returns an empty logical array, even if `PropertyName` is a property of `obj`.

---

While `isprop` returns true if the class of an object defines a property of that name, classes can control access to property values by defining property attributes. Property access can be defined as:

- Readable and writable
- Read only
- Write only
- Accessible only to certain class methods

Therefore, `isprop` might indicate that a property exists, but you might not be able to access that property. For more information, see “Getting Information About Properties”.

## Examples

This example uses `isprop` to determine if `XDataSource` is a property of object `h` before attempting to set the property value:

```
h = plot(1:10);
if isprop(h, 'XDataSource')
 set(h, 'XDataSource', 'x')
```

```
else
 error(['XDataSource not a property of class ',class(h)])
end
```

Since XDataSource is a property of h, its value is set to 'x'.

**See Also**

[properties](#) | [ismethod](#)

**Tutorials**

- “Properties”

# isprop (COM)

---

**Purpose** Determine whether input is COM object property

**Syntax**

```
tf = h.isprop('propertyname')
tf = isprop(h, 'propertyname')
```

**Description** `tf = h.isprop('propertyname')` returns logical 1 (true) if the specified name is a property of COM object `h`. Otherwise, returns logical 0 (false).

`tf = isprop(h, 'propertyname')` is an alternate syntax.

COM functions are available on Microsoft Windows systems only.

**Examples** Test a property of an instance of a Microsoft Excel application:

```
h = actxserver('Excel.Application');
isprop(h, 'UsableWidth')
```

MATLAB returns true, `UsableWidth` is a property.

---

Try the same test on `SaveWorkspace`:

```
isprop(h, 'SaveWorkspace')
```

MATLAB returns false. `SaveWorkspace` is not a property; it is a method.

**See Also** `inspect` | `ismethod` | `isevent`

**How To**

- “Exploring Properties”

|                        |                                                                                                                                                                                                                                                                                                                                                                                                                                                                                                                                                                                                                                                                                                                                                                |
|------------------------|----------------------------------------------------------------------------------------------------------------------------------------------------------------------------------------------------------------------------------------------------------------------------------------------------------------------------------------------------------------------------------------------------------------------------------------------------------------------------------------------------------------------------------------------------------------------------------------------------------------------------------------------------------------------------------------------------------------------------------------------------------------|
| <b>Purpose</b>         | Determine whether categories of categorical array are protected                                                                                                                                                                                                                                                                                                                                                                                                                                                                                                                                                                                                                                                                                                |
| <b>Syntax</b>          | <code>tf = isprotected(A)</code>                                                                                                                                                                                                                                                                                                                                                                                                                                                                                                                                                                                                                                                                                                                               |
| <b>Description</b>     | <p><code>tf = isprotected(A)</code> returns logical 1 (true) if the categories of A are protected. Otherwise, <code>isprotected</code> returns logical 0 (false).</p> <ul style="list-style-type: none"><li>• <code>true</code> — When you assign new values to B, the values must belong to one of the existing categories. Therefore, you only can combine arrays that have the same categories. To add new categories to B, you must use the <code>addcats</code> function.</li><li>• <code>false</code> — When you assign new values to B, the categories update automatically. Therefore, you can combine (nonordinal) categorical arrays that have different categories. The categories can update to include the categories from both arrays.</li></ul> |
| <b>Input Arguments</b> | <p><b>A - Categorical array</b><br/>vector   matrix   multidimensional array</p> <p>Categorical array, specified as a vector, matrix, or multidimensional array.</p> <p>The categories of ordinal categorical arrays are always protected.</p>                                                                                                                                                                                                                                                                                                                                                                                                                                                                                                                 |
| <b>Examples</b>        | <p><b>Determine Whether Categories Are Protected</b></p> <p>Create a categorical array containing the sizes of 10 objects. Use the names <code>small</code>, <code>medium</code>, and <code>large</code> for the values <code>'S'</code>, <code>'M'</code>, and <code>'L'</code>.</p> <pre>valueset = {'S','M','L'}; catnames = {'small','medium','large'};</pre> <pre>A = categorical({'M';'L';'S';'S';'M';'L';'M';'L';'M';'S'},...     valueset,catnames,'Ordinal',true)</pre> <p>A =</p> <pre>     medium</pre>                                                                                                                                                                                                                                             |

# isprotected

---

```
large
small
small
medium
large
medium
large
medium
small
```

A is a 10-by-1 categorical array.

Display the categories of A.

```
categories(A)
```

```
ans =
```

```
'small'
'medium'
'large'
```

Determine whether the categories of A are protected.

```
tf = isprotected(A)
```

```
tf =
```

```
1
```

Since A is an ordinal categorical array, the categories are protected. If you try to add a new value that does not belong to one of the existing categories, for example `A(11) = 'xlarge'`, then MATLAB returns an error.

First, use `addcats` to add a new category for `xlarge`.

```
A = addcats(A, 'xlarge', 'After', 'large');
```



Since A is protected, you can now add a value for `xlarge` since it has an existing category.

```
A(11) = 'xlarge'
```

```
A =
```

```
 medium
 large
 small
 small
 medium
 large
 medium
 large
 medium
 small
 xlarge
```

A is now a 11-by-1 categorical array with four categories, such that `small < medium < large < xlarge`.

## See Also

`categorical` | `categories`

## Related Examples

- “Work with Protected Categorical Arrays”

# isreal

---

**Purpose** Determine if array is real

**Syntax** `tf = isreal(A)`

**Description** `tf = isreal(A)` returns logical 1 (true) if *A* does not have an imaginary part. Otherwise, it returns logical 0 (false).

If *A* has a stored imaginary part with value 0, then `isreal(A)` returns logical 0 (false).

**Input Arguments**

**A - Input array**

scalar | vector | matrix | multidimensional array

Input array, specified as a scalar, vector, matrix, or multidimensional array.

- For numeric data types, if *A* does not have an imaginary part, `isreal` returns true; if *A* does have an imaginary part `isreal` returns false.
- For logical and char data types, `isreal` always returns true.
- For table, cell, struct, function\_handle, and object data types, `isreal` always returns false.

**Data Types**

single | double | int8 | int16 | int32 | int64 | uint8 | uint16 | uint32 | uint64 | logical | char | struct | table | cell | function\_handle

**Complex Number Support:** Yes

**Examples**

**Determine If Matrix Contains All Real Values**

Define a 3-by-4 matrix, *A*.

```
A = [7 3+4i 2 5i;...
 2i 1+3i 12 345;...
 52 108 78 3];
```

Determine if the array is real.

```
tf = isreal(A)
```

```
tf =
```

```
0
```

Since A contains complex elements, `isreal` returns false.

### **Define Complex Number with Zero-Valued Imaginary Part**

Use the `complex` function to create a scalar, A, with zero-valued imaginary part.

```
A = complex(12)
```

```
A =
```

```
12.0000 + 0.0000i
```

Determine if A is real.

```
tf = isreal(A)
```

```
tf =
```

```
0
```

A is not real because it has an imaginary part, even though the value of the imaginary part is 0.

Determine if A contains any elements with zero-valued imaginary part.

```
~any(imag(A))
```

```
ans =
```

```
1
```

A contains elements with zero-valued imaginary part.

## Computation Resulting in Zero-Valued Imaginary Part

Define two complex scalars,  $x$  and  $y$ .

```
x=3+4i;
y=5-4i;
```

Determine if the addition of two complex scalars,  $x$  and  $y$ , is real.

```
A = x+y
```

```
A =
```

```
8
```

MATLAB drops the zero imaginary part.

```
isreal(A)
```

```
ans =
```

```
1
```

$A$  is real since it does not have an imaginary part.

## Find Real Elements in Cell Array

Create a cell array.

```
C{1,1} = pi; % double
C{2,1} = 'John Doe'; % char array
C{3,1} = 2 + 4i; % complex double
C{4,1} = ispc; % logical
C{5,1} = magic(3); % double array
C{6,1} = complex(5,0) % complex double
```

```
C =
```

```
[3.1416]
'John Doe'
```

```

 [2.0000 + 4.0000i]
 [1]
 [3x3 double]
 [5.0000 + 0.0000i]

```

C is a 1-by-6 cell array.

Loop over the elements of a cell array to distinguish between real and complex elements.

```

for k = 1:6
x(k,1) = isreal(C{k,1});
end

```

x

x =

```

 1
 1
 0
 1
 1
 0

```

All but C{3,1} and C{6,1} are real arrays.

## Tips

- `isreal(complex(A))` always returns `false`, even when the imaginary part is all zeros.
- `~isreal(x)` detects arrays that have an imaginary part, even if it is all zeros.

## See Also

`complex` | `isnumeric` | `isnan` | `isprime` | `isfinite` | `isinf` | `isa`

## Concepts

- “Complex Numbers”

# isrow

---

**Purpose** Determine whether input is row vector

**Syntax** `isrow(V)`

**Description** `isrow(V)` returns logical 1 (true) if `size(V)` returns `[1 n]` with a nonnegative integer value `n`, and logical 0 (false) otherwise.

**Examples** Determine if a vector is a row. This example is a column so `isrow` returns 0:

```
V = rand(5,1);
isrow(V)
ans =
 0
```

Transpose the vector to make it a row. `isrow` returns 1:

```
V1 = V';
isrow(V1)
ans =
 1
```

**See Also** `iscolumn` | `ismatrix` | `isscalar` | `isvector`

**Purpose** Determine whether input is scalar

**Syntax** `isscalar(A)`

**Description** `isscalar(A)` returns logical 1 (true) if `size(A)` returns [1 1], and logical 0 (false) otherwise.

**Examples** Test matrix A and one element of the matrix:

```
A = rand(5);
```

```
isscalar(A)
ans =
 0
```

```
isscalar(A(3,2))
ans =
 1
```

**See Also** `isvector` | `ismatrix` | `isrow` | `iscolumn` | `islogical` | `ischar` | `isa` | `is*`

# issorted

---

**Purpose** Determine whether set elements are in sorted order

**Syntax**  
TF = issorted(A)  
TF = issorted(A, 'rows')

**Description** TF = issorted(A) returns logical 1 (true) if the elements of A are in sorted order, and logical 0 (false) otherwise. Input A can be a vector or an N-by-1 or 1-by-N cell array of strings. A is considered to be sorted if A and the output of sort(A) are equal.

TF = issorted(A, 'rows') returns logical 1 (true) if the rows of two-dimensional matrix A are in sorted order, and logical 0 (false) otherwise. Matrix A is considered to be sorted if A and the output of sortrows(A) are equal.

---

**Note** Only the issorted(A) syntax supports A as a cell array of strings.

The issorted(A, 'rows') syntax supports A as a categorical array, but not as a cell array of strings.

---

**Tips** For character arrays, issorted uses ASCII, rather than alphabetical, order.

You cannot use issorted on arrays of greater than two dimensions.

**Examples** **Example 1 – Using issorted on a vector**

```
A = [5 12 33 39 78 90 95 107 128 131];
```

```
issorted(A)
ans =
 1
```

**Example 2 – Using issorted on a matrix**

```
A = magic(5)
```



```
A =
 17 24 1 8 15
 23 5 7 14 16
 4 6 13 20 22
 10 12 19 21 3
 11 18 25 2 9
```

```
issorted(A, 'rows')
ans =
 0
```

```
B = sortrows(A)
B =
 4 6 13 20 22
 10 12 19 21 3
 11 18 25 2 9
 17 24 1 8 15
 23 5 7 14 16
```

```
issorted(B)
ans =
 1
```

### Example 3 – Using issorted on a cell array

```
x = {'one'; 'two'; 'three'; 'four'; 'five'};
issorted(x)
ans =
 0
```

```
y = sort(x)
y =
 'five'
 'four'
 'one'
 'three'
 'two'
```

# issorted

---

`issorted(y)`

## **See Also**

`sort` | `sortrows` | `ismember` | `unique` | `intersect` | `union` | `setdiff`  
| `setxor` | `is*`

**Purpose** Array elements that are space characters

**Syntax** `tf = isspace('str')`

**Description** `tf = isspace('str')` returns an array the same size as 'str' containing logical 1 (true) where the elements of `str` are Unicode<sup>®</sup>-represented whitespace characters, and logical 0 (false) where they are not.

Whitespace characters for which `isspace` returns true include tab, line feed, vertical tab, form feed, carriage return, and space, in addition to a number of other Unicode characters. To see all characters for which `isspace` returns true, enter the following command, and then look up the returned decimal codes in a Unicode reference:

```
find(isspace(char(1):char(intmax('uint16'))))
```

## Examples

```
isspace(' Find spa ces ')
Columns 1 through 13
 1 1 0 0 0 0 1 0 0 0 1 0 0
Columns 14 through 15
 0 1
```

**See Also** `isletter` | `isstrprop` | `ischar` | `strings` | `isa` | `is*`

# issparse

---

**Purpose** Determine whether input is sparse

**Syntax** TF = issparse(S)

**Description** TF = issparse(S) returns logical 1 (true) if the storage class of S is sparse and logical 0 (false) otherwise.

**See Also** is\* | sparse | full

**Purpose** Determine whether input is character array

---

**Note** `isstr` is not recommended. Use `ischar` instead.

---

**See Also** `ischar` | `isa` | `is*`

# isstrprop

---

**Purpose** Determine whether string is of specified category

**Syntax** `tf = isstrprop('str', 'category')`

**Description** `tf = isstrprop('str', 'category')` returns a logical array the same size as `str` containing logical 1 (true) where the elements of `str` belong to the specified `category`, and logical 0 (false) where they do not.

The `str` input can be a character array, cell array, or any MATLAB numeric type. If `str` is a cell array, then the return value is a cell array of the same shape as `str`.

The `category` input can be any of the strings shown in the left column below:

| Category | Description                                                                                                                                                                                                                                                                                                                                                         |
|----------|---------------------------------------------------------------------------------------------------------------------------------------------------------------------------------------------------------------------------------------------------------------------------------------------------------------------------------------------------------------------|
| alpha    | True for those elements of <code>str</code> that are alphabetic                                                                                                                                                                                                                                                                                                     |
| alphanum | True for those elements of <code>str</code> that are alphanumeric                                                                                                                                                                                                                                                                                                   |
| cntrl    | True for those elements of <code>str</code> that are control characters (for example, <code>char(0:20)</code> )                                                                                                                                                                                                                                                     |
| digit    | True for those elements of <code>str</code> that are numeric digits                                                                                                                                                                                                                                                                                                 |
| graphic  | True for those elements of <code>str</code> that are graphic characters. These are all values that represent any characters except for the following:<br><br>unassigned, space, line separator, paragraph separator, control characters, Unicode format control characters, private user-defined characters, Unicode surrogate characters, Unicode other characters |
| lower    | True for those elements of <code>str</code> that are lowercase letters                                                                                                                                                                                                                                                                                              |
| print    | True for those elements of <code>str</code> that are graphic characters, plus <code>char(32)</code>                                                                                                                                                                                                                                                                 |

| Category | Description                                                                                                                                                                                                                         |
|----------|-------------------------------------------------------------------------------------------------------------------------------------------------------------------------------------------------------------------------------------|
| punct    | True for those elements of <code>str</code> that are punctuation characters                                                                                                                                                         |
| wspace   | True for those elements of <code>str</code> that are white-space characters. This range includes the ANSI® C definition of white space, { ' ', '\t', '\n', '\r', '\v', '\f' }, in addition to a number of other Unicode characters. |
| upper    | True for those elements of <code>str</code> that are uppercase letters                                                                                                                                                              |
| xdigit   | True for those elements of <code>str</code> that are valid hexadecimal digits                                                                                                                                                       |

## Tips

Numbers of type `double` are converted to `int32` according to MATLAB rules of double-to-integer conversion. Numbers of type `int64` and `uint64` bigger than `int32(inf)` saturate to `int32(inf)`.

MATLAB classifies the elements of the `str` input according to the Unicode definition of the specified category. If the numeric value of an element in the input array falls within the range that defines a Unicode character category, then this element is classified as being of that category. The set of Unicode character codes includes the set of ASCII character codes, but also covers a large number of languages beyond the scope of the ASCII set. The classification of characters is dependent on the global location of the platform on which MATLAB is installed.

Whitespace characters for which the `wspace` option returns `true` include tab, line feed, vertical tab, form feed, carriage return, and space, in addition to a number of other Unicode characters. To see all characters for which the `wspace` option returns `true`, enter the following command, and then look up the returned decimal codes in a Unicode reference:

```
find(isstrprop(char(1):char(intmax('uint16')), 'wspace'))
```

## Examples

Test for alphabetic characters in a string:

```
A = isstrprop('abc123def', 'alpha')
```

# isstrprop

---

```
A =
 1 1 1 0 0 0 1 1 1
```

Test for numeric digits in a string:

```
A = isstrprop('abc123def', 'digit')
A =
 0 0 0 1 1 1 0 0 0
```

Test for hexadecimal digits in a string:

```
A = isstrprop('abcd1234efgh', 'xdigit')
A =
 1 1 1 1 1 1 1 1 1 0 0
```

Test for numeric digits in a character array:

```
A = isstrprop(char([97 98 99 49 50 51 101 102 103]), ...
 'digit')
A =
 0 0 0 1 1 1 0 0 0
```

Test for alphabetic characters in a two-dimensional cell array:

```
A = isstrprop({'abc123def'; '456ghi789'}, 'alpha')
A =
 [1x9 logical]
 [1x9 logical]
```

```
A{:, :}
ans =
 1 1 1 0 0 0 1 1 1
 0 0 0 1 1 1 0 0 0
```

Test for white-space characters in a string:

```
A = isstrprop(sprintf('a bc\n'), 'wspace')
A =
 0 1 0 0 1
```



## See Also

strings | ischar | isletter | isspace | iscellstr | isnumeric  
| isa | is\*

# isstruct

---

**Purpose** Determine whether input is structure array

**Syntax** `tf = isstruct(A)`

**Description** `tf = isstruct(A)` returns logical 1 (true) if A is a MATLAB structure and logical 0 (false) otherwise.

**Examples**

```
patient.name = 'John Doe';
patient.billing = 127.00;
patient.test = [79 75 73; 180 178 177.5; 220 210 205];

isstruct(patient)

ans =

 1
```

**See Also** [struct](#) | [istable](#) | [isfield](#) | [iscell](#) | [ischar](#) | [isobject](#) | [isnumeric](#) | [islogical](#) | [isa](#) | [is\\*](#)

**How To**

- dynamic field names

**Purpose** Determine if version is Student Version

**Syntax** `tf = isstudent`

**Description** `tf = isstudent` returns logical 1 (true) if the version of MATLAB software is the Student Version, and returns logical 0 (false) for commercial versions.

**See Also** `ver` | `version` | `license` | `ispc` | `isunix` | `is*`

# issymmetric

---

**Purpose** Determine if matrix is symmetric or skew-symmetric

**Syntax**  
`tf = issymmetric(A)`  
`tf = issymmetric(A,skewOption)`

**Description** `tf = issymmetric(A)` returns logical 1 (true) if square matrix A is symmetric; otherwise, it returns logical 0 (false).

`tf = issymmetric(A,skewOption)` specifies the type of the test. Specify `skewOption` as 'skew' to determine if A is skew-symmetric.

## Input Arguments

### **A - Input matrix**

numeric matrix

Input matrix, specified as a numeric matrix. If A is not square, then `issymmetric` returns logical 0 (false).

### **Data Types**

single | double

**Complex Number Support:** Yes

### **skewOption - Test type**

'nonskew' (default) | 'skew'

Test type, specified as 'nonskew' (default) or 'skew'. Specify 'skew' to test whether A is skew-symmetric. Specifying `issymmetric(A, 'nonskew')` is equivalent to `issymmetric(A)`.

### **Data Types**

char

## Examples

### **Test if Hermitian Matrix Is Symmetric**

Create a 3-by-3 matrix.

```
A = [1 0 1i; 0 1 0; -1i 0 1]
```

```
A =
```

```
1.0000 + 0.0000i 0.0000 + 0.0000i 0.0000 + 1.0000i
0.0000 + 0.0000i 1.0000 + 0.0000i 0.0000 + 0.0000i
0.0000 - 1.0000i 0.0000 + 0.0000i 1.0000 + 0.0000i
```

The matrix is Hermitian and has a real-valued diagonal.

Test whether the matrix is symmetric.

```
tf = issymmetric(A)
```

```
tf =
```

```
0
```

The result is logical 0 (false) because A is not symmetric. In this case, A is equal to its complex conjugate transpose, A', but not its nonconjugate transpose, A.'.

Change the element in A(3,1) to be 1i.

```
A(3,1) = 1i;
```

Determine whether the modified matrix is symmetric.

```
tf = issymmetric(A)
```

```
tf =
```

```
1
```

The matrix, A, is now symmetric because it is equal to its nonconjugate transpose, A.'.

## Test if Matrix Is Skew-Symmetric

Create a 4-by-4 matrix.

```
A = [0 1 -2 5; -1 0 3 -4; 2 -3 0 6; -5 4 -6 0]
```

# issymmetric

---

```
A =

 0 1 -2 5
 -1 0 3 -4
 2 -3 0 6
 -5 4 -6 0
```

The matrix is real and has a diagonal of zeros.

Specify `skewOption` as 'skew' to determine whether the matrix is skew-symmetric.

```
tf = issymmetric(A, 'skew')
```

```
tf =
```

```
 1
```

The matrix,  $A$ , is skew-symmetric since it is equal to the negation of its nonconjugate transpose,  $-A.'$

## Definitions

### Symmetric Matrix

- A square matrix,  $A$ , is symmetric if it is equal to its nonconjugate transpose,  $A = A.'$

In terms of the matrix elements, this means that

$$a_{i,j} = a_{j,i} .$$

- Since real matrices are unaffected by complex conjugation, a real matrix that is symmetric is also Hermitian. For example, the matrix

$$A = \begin{bmatrix} 1 & 0 & 1 \\ 0 & 2 & 0 \\ 1 & 0 & 1 \end{bmatrix}$$

is both symmetric and Hermitian.

## Skew-Symmetric Matrix

- A square matrix,  $A$ , is skew-symmetric if it is equal to the negation of its nonconjugate transpose,  $A = -A'$ .

In terms of the matrix elements, this means that

$$a_{i,j} = -a_{j,i}.$$

- Since real matrices are unaffected by complex conjugation, a real matrix that is skew-symmetric is also skew-Hermitian. For example, the matrix

$$A = \begin{bmatrix} 0 & -1 \\ 1 & 0 \end{bmatrix}$$

is both skew-symmetric and skew-Hermitian.

## See Also

[ishermitian](#) | [isreal](#) | [transpose](#) | [ctranspose](#)

# Tiff.isTiled

---

**Purpose** Determine if tiled image

**Syntax** `bool = tiffobj.isTiled()`

**Description** `bool = tiffobj.isTiled()` returns true if the image has a tiled organization and false if the image has a stripped organization.

## **Examples** **Determine if Image Has Tiled Organization**

Open a Tiff object and check if the image in the TIFF file has a tiled or stripped organization.

```
t = Tiff('example.tif', 'r');
tf = t.isTiled()
```

```
tf =
```

```
1
```

The image has a tiled organization.

Close the Tiff object.

```
t.close();
```

**References** This method corresponds to the `TIFFIsTiled` function in the LibTIFF C API. To use this method, you must be familiar with the TIFF specification and technical notes. View this documentation at [LibTIFF - TIFF Library and Utilities](#).

**Tutorials**

- “Exporting Image Data and Metadata to TIFF Files”
- “Reading Image Data and Metadata from TIFF Files”



**Purpose** Determine whether input is table

**Syntax** `tf = istable(T)`

**Description** `tf = istable(T)` returns logical 1 (true) if T is a table. Otherwise, it returns logical 0 (false) otherwise.

**Input Arguments** **T - Input variable**  
workspace variable

Input variable, specified as a workspace variable. T can be any data type.

**Examples** **Determine if Workspace Variable Is Table**

Create a workspace variable, T.

```
T = table(['M';'F';'M'],[45 45;41 32;40 34],...
 {'NY';'CA';'MA'},[true;false;false])
```

T =

| Var1 | Var2 | Var3 | Var4 |       |
|------|------|------|------|-------|
| M    | 45   | 45   | 'NY' | true  |
| F    | 41   | 32   | 'CA' | false |
| M    | 40   | 34   | 'MA' | false |

Verify that the workspace variable, T, is a table.

```
istable(T)
```

```
ans =
```

```
1
```

T is a table.

## Determine if Subset of Table Is Table

Create a table, T.

```
T = table(['M';'F';'M'],[45 45;41 32;40 34],...
 {'NY';'CA';'MA'},[true;false;false])
```

T =

| Var1 | Var2 |    | Var3 | Var4  |
|------|------|----|------|-------|
| M    | 45   | 45 | 'NY' | true  |
| F    | 41   | 32 | 'CA' | false |
| M    | 40   | 34 | 'MA' | false |

Determine if the subset of table T that contains only the second and fourth variables is a table.

```
istable(T{:[2 4]})
```

ans =

0

Conversely, accessing data with curly braces, T{:[2 4]}, returns a matrix and not a table.

## See Also

[table](#) | [iscell](#) | [isstruct](#) | [isnumeric](#) | [isobject](#) | [islogical](#)

**Purpose** Determine if matrix is lower triangular

**Syntax** `tf = istril(A)`

**Description** `tf = istril(A)` returns logical 1 (true) if A is a lower triangular matrix; otherwise, it returns logical 0 (false).

**Input Arguments** **A - Input array**  
 numeric array  
 Input array, specified as a numeric array. `istril` returns logical 0 (false) if A has more than two dimensions.

**Data Types**  
 single | double  
**Complex Number Support:** Yes

**Examples** **Test Lower Triangular Matrix**

Create a 5-by-5 matrix.

```
D = tril(magic(5))
```

D =

```

 17 0 0 0 0
 23 5 0 0 0
 4 6 13 0 0
 10 12 19 21 0
 11 18 25 2 9
```

Test D to see if it is lower triangular.

```
istril(D)
```

ans =

```

 1
```

The result is logical 1 (true) because all elements above the main diagonal are zero.

## Test Matrix of Zeros

Create a 5-by-5 matrix of zeros.

```
Z = zeros(5);
```

Test Z to see if it is lower triangular.

```
istril(Z)
```

```
ans =
```

```
1
```

The result is logical 1 (true) because a lower triangular matrix can have any number of zeros on its main diagonal.

## Definitions

### Lower Triangular Matrix

A matrix is lower triangular if all elements above the main diagonal are zero. Any number of the elements on the main diagonal can also be zero.

For example, the matrix

$$A = \begin{pmatrix} 1 & 0 & 0 & 0 \\ -1 & 1 & 0 & 0 \\ -2 & -2 & 1 & 0 \\ -3 & -3 & -3 & 1 \end{pmatrix}$$

is lower triangular. A diagonal matrix is both upper and lower triangular.

## Tips

- Use the `tril` function to produce lower triangular matrices for which `istril` returns logical 1 (true).

- The functions `isdiag`, `istriu`, and `istril` are special cases of the function `isbanded`, which can perform all of the same tests with suitably defined upper and lower bandwidths. For example, `istril(A) == isbanded(A,size(A,1),0)`.

**See Also**`isdiag | istriu | diag | triu | tril`

# istriu

---

**Purpose** Determine if matrix is upper triangular

**Syntax** `tf = istriu(A)`

**Description** `tf = istriu(A)` returns logical 1 (true) if A is an upper triangular matrix; otherwise, it returns logical 0 (false).

**Input Arguments** **A - Input array**  
numeric array

Input array, specified as a numeric array. `istriu` returns logical 0 (false) if A has more than two dimensions.

**Data Types**  
single | double  
**Complex Number Support:** Yes

**Examples** **Test Upper Triangular Matrix**

Create a 5-by-5 matrix.

```
A = triu(magic(5))
```

```
A =
```

```
 17 24 1 8 15
 0 5 7 14 16
 0 0 13 20 22
 0 0 0 21 3
 0 0 0 0 9
```

Test A to see if it is upper triangular.

```
istriu(A)
```

```
ans =
```

```
 1
```

The result is logical 1 (true) because all elements below the main diagonal are zero.

### Test Matrix of Zeros

Create a 5-by-5 matrix of zeros.

```
Z = zeros(5);
```

Test Z to see if it is upper triangular.

```
istriu(Z)
```

```
ans =
```

```
1
```

The result is logical 1 (true) because an upper triangular matrix can have any number of zeros on the main diagonal.

## Definitions

### Upper Triangular Matrix

A matrix is upper triangular if all elements below the main diagonal are zero. Any number of the elements on the main diagonal can also be zero.

For example, the matrix

$$A = \begin{pmatrix} 1 & -1 & -1 & -1 \\ 0 & 1 & -2 & -2 \\ 0 & 0 & 1 & -3 \\ 0 & 0 & 0 & 1 \end{pmatrix}$$

is upper triangular. A diagonal matrix is both upper and lower triangular.

## Tips

- Use the `triu` function to produce upper triangular matrices for which `istriu` returns logical 1 (true).

# istriu

---

- The functions `isdiag`, `istriu`, and `istril` are special cases of the function `isbanded`, which can perform all of the same tests with suitably defined upper and lower bandwidths. For example, `istriu(A) == isbanded(A,0,size(A,2))`.

## See Also

`isdiag` | `istril` | `diag` | `triu` | `tril`



**Purpose** Find undefined elements in categorical array

**Syntax** `TF = isundefined(A)`

**Description** `TF = isundefined(A)` returns a logical array, `TF`, that indicates which elements in the categorical array, `A`, contain undefined values. `isundefined` returns logical 1 (true) for undefined elements; otherwise it returns logical 0 (false). The size of `TF` is the same as the size of `A`.

Any elements in `A` without a corresponding category are undefined. Undefined values are similar to NaN in numeric arrays.

**Input Arguments**

**A - Categorical array**

vector | matrix | multidimensional array

Categorical array, specified as a vector, matrix, or multidimensional array.

**Examples**

**Categorical Array with Undefined Values**

Create a categorical array, `A`, from numeric values where 1, 2, and 3 represent red, green, and blue respectively.

```
A = categorical([4 1; 2 3; 2 1; 3 4; 1 1],1:3,{'red','green','blue'})
```

```
A =
```

```

<undefined> red
green blue
green red
blue <undefined>
red red

```

`A` is a 5-by-2 categorical array with three categories: red, green, and blue. Array elements corresponding to the numeric value 4 in the input array to the `categorical` function do not have a corresponding category. Therefore, they are undefined in the output categorical array, `A`.

# isundefined

---

Find undefined elements in A.

```
TF = isundefined(A)
```

```
TF =
```

```
 1 0
 0 0
 0 0
 0 1
 0 0
```

A(1,1) and A(4,2) are undefined.

## See Also

`ismember`

**Purpose** Determine if version is for UNIX platform

**Syntax** `tf = isunix`

**Description** `tf = isunix` returns logical 1 (true) if the version of MATLAB software is for the UNIX platform or the Apple Mac OS X platform. Otherwise, it returns logical 0 (false).

**See Also** `ispc` | `ismac` | `computer` | `isstudent` | `is*`

# isvalid (handle)

---

**Purpose** Is object valid handle class object

**Syntax** H1 = isvalid(Hobj)

**Description** H1 = isvalid(Hobj) returns a logical array (or scalar if Hobj is scalar) in which each element is true if the corresponding element in Hobj is a valid handle. This method is Sealed, so you cannot override it in a handle subclass.

---

**Note** This method does not work with Handle Graphics objects. To determine the validity of a Handle Graphics object handle, use the ishghandle function.

---

**See Also** delete (handle) | handle

**How To** • “Testing Handle Validity”

|                    |                                                                                                                                                                                                                                                                                                                                                                                                   |
|--------------------|---------------------------------------------------------------------------------------------------------------------------------------------------------------------------------------------------------------------------------------------------------------------------------------------------------------------------------------------------------------------------------------------------|
| <b>Purpose</b>     | Determine whether serial port objects are valid                                                                                                                                                                                                                                                                                                                                                   |
| <b>Syntax</b>      | <code>out = isvalid(obj)</code>                                                                                                                                                                                                                                                                                                                                                                   |
| <b>Description</b> | <code>out = isvalid(obj)</code> returns the logical array <code>out</code> , which contains a 0 where the elements of the serial port object, <code>obj</code> are invalid serial port objects and a 1 where the elements of <code>obj</code> are valid serial port objects.                                                                                                                      |
| <b>Tips</b>        | <code>obj</code> becomes invalid after it is removed from memory with the <code>delete</code> function. Because you cannot connect an invalid serial port object to the device, you should remove it from the workspace with the <code>clear</code> command.                                                                                                                                      |
| <b>Examples</b>    | <p>Suppose you create the following two serial port objects.</p> <pre>s1 = serial('COM1');<br/>s2 = serial('COM1');</pre> <p><code>s2</code> becomes invalid after it is deleted.</p> <pre>delete(s2)</pre> <p><code>isvalid</code> verifies that <code>s1</code> is valid and <code>s2</code> is invalid.</p> <pre>sarray = [s1 s2];<br/>isvalid(sarray)</pre> <pre>ans =<br/>     1     0</pre> |
| <b>See Also</b>    | <code>clear</code>   <code>delete</code>                                                                                                                                                                                                                                                                                                                                                          |

# isvarname

---

**Purpose** Determine whether input is valid variable name

**Syntax** `tf = isvarname('str')`  
`isvarname str`

**Description** `tf = isvarname('str')` returns logical 1 (true) if the string `str` is a valid MATLAB variable name and logical 0 (false) otherwise. A valid variable name is a character string of letters, digits, and underscores, totaling not more than `namelengthmax` characters and beginning with a letter.

MATLAB keywords are not valid variable names. Type the command `iskeyword` with no input arguments to see a list of MATLAB keywords.

`isvarname str` uses the MATLAB command format.

**Examples** This variable name is valid:

```
isvarname foo
ans =
 1
```

This one is not because it starts with a number:

```
isvarname 8th_column
ans =
 0
```

If you are building strings from various pieces, place the construction in parentheses.

```
d = date;

isvarname(['Monday_', d(1:2)])
ans =
 1
```

## See Also

`matlab.lang.makeValidName` | `matlab.lang.makeUniqueStrings` |  
`isglobal` | `iskeyword` | `namelengthmax` | `is*`

# isvector

---

**Purpose** Determine whether input is vector

**Syntax** `isvector(A)`

**Description** `isvector(A)` returns logical 1 (true) if `size(A)` returns `[1 n]` or `[n 1]` with a nonnegative integer value `n`, and logical 0 (false) otherwise.

**Examples** Test matrix A and its row and column vectors:

```
A = rand(5);

isvector(A)
ans =
 0

isvector(A(3, :))
ans =
 1

isvector(A(:, 2))
ans =
 1
```

**See Also** `iscolumn` | `ismatrix` | `isrow` | `isscalar` | `isempty` | `isnumeric` | `islogical` | `ischar` | `isa` | `is*`



---

|                        |                                                                                                                                                                                                                                                                                                                                                                                                                                                                                                                                                                                                                                                                       |
|------------------------|-----------------------------------------------------------------------------------------------------------------------------------------------------------------------------------------------------------------------------------------------------------------------------------------------------------------------------------------------------------------------------------------------------------------------------------------------------------------------------------------------------------------------------------------------------------------------------------------------------------------------------------------------------------------------|
| <b>Purpose</b>         | Imaginary unit                                                                                                                                                                                                                                                                                                                                                                                                                                                                                                                                                                                                                                                        |
| <b>Syntax</b>          | <pre>1j z = a + bj z = x + 1j*y</pre>                                                                                                                                                                                                                                                                                                                                                                                                                                                                                                                                                                                                                                 |
| <b>Description</b>     | <p>1j returns the basic imaginary unit. j is equivalent to <code>sqrt(-1)</code>.</p> <p>You can use j to enter complex numbers. You also can use the character i as the imaginary unit. To create a complex number without using i and j, use the <code>complex</code> function.</p> <p><code>z = a + bj</code> returns a complex numerical constant, z.</p> <p><code>z = x + 1j*y</code> returns a complex array, z.</p>                                                                                                                                                                                                                                            |
| <b>Input Arguments</b> | <p><b>a - Real component of complex scalar</b><br/>scalar<br/>Real component of a complex scalar, specified as a scalar.</p> <p><b>Data Types</b><br/>single   double</p> <p><b>b - Imaginary component of complex scalar</b><br/>scalar<br/>Imaginary component of a complex scalar, specified as a scalar.</p> <p>If b is <code>double</code>, you can use the character, j, without a multiplication sign as a suffix in forming the complex numerical constant.</p> <p><b>Example:</b> 7j</p> <p>If b is <code>single</code>, you must use a multiplication sign when forming the complex numerical constant.</p> <p><b>Example:</b> <code>single(7)*j</code></p> |

**Data Types**

single | double

**x - Real component of complex array**

scalar | vector | matrix | multidimensional array

Real component of a complex array, specified as a scalar, vector, matrix, or multidimensional array.

The size of  $x$  must match the size of  $y$ , unless one is a scalar. If either  $x$  or  $y$  is a scalar, MATLAB expands the scalar to match the size of the other input.

single can combine with double.

**Data Types**

single | double

**y - Imaginary component of complex array**

scalar | vector | matrix | multidimensional array

Imaginary component of a complex array, specified as a scalar, vector, matrix, or multidimensional array.

The size of  $x$  must match the size of  $y$ , unless one is a scalar. If either  $x$  or  $y$  is a scalar, MATLAB expands the scalar to match the size of the other input.

single can combine with double.

**Data Types**

single | double

**Output Arguments****z - Complex array**

scalar | vector | matrix | multidimensional array

Complex array, returned as a scalar, vector, matrix, or multidimensional array.

The size of  $z$  is the same as the input arguments.

`z` is `single` if at least one input argument is `single`. Otherwise, `z` is `double`.

## Examples

### Complex Scalar

Create a complex scalar and use the character, `j`, without a multiplication sign as a suffix in forming a complex numerical constant.

```
z = 1+2j
```

```
z =
```

```
1.0000 + 2.0000i
```

### Complex Vector

Create a complex vector from two 4-by-1 vectors of real numbers.

```
x = [1:4]';
```

```
y = [8:-2:2]';
```

```
z = x+1j*y
```

```
z =
```

```
1.0000 + 8.0000i
```

```
2.0000 + 6.0000i
```

```
3.0000 + 4.0000i
```

```
4.0000 + 2.0000i
```

`z` is a 4-by-1 complex vector.

### Complex Exponential

Create a complex scalar representing a complex vector with radius, `r`, and angle from the origin, `theta`.

```
r = 4;
```

```
theta = pi/4;
```

```
z = r*exp(1j*theta)
```

```
z =
```

```
2.8284 + 2.8284i
```

## Tips

- For speed and improved robustness in complex arithmetic, use `1i` and `1j` instead of `i` and `j`.
- Since `j` is a function, it can be overridden and used as a variable. However, it is best to avoid using `i` and `j` for variable names if you intend to use them in complex arithmetic.
- Use the `complex` function to create a complex output in the following cases:
  - When the names `i` and `j` might be used for other variables (and do not equal `sqrt(-1)`)
  - When the inputs are not `double` or `single`
  - When the imaginary component is all zeros

## See Also

`conj` | `complex` | `imag` | `i` | `real`

## Concepts

- “Complex Numbers”

**Purpose** Add entries to dynamic Java class path

**Syntax** `javaaddpath(dpath)`  
`javaaddpath(dpath, '-end')`

**Description** `javaaddpath(dpath)` adds one or more folders or Java Archive (JAR) files to the beginning of the current dynamic class path.

`javaaddpath(dpath, '-end')` adds files or folders to the end of the path.

- Tips**
- MATLAB calls the `clear java` command whenever you change the dynamic path. This command clears the definitions of all Java classes defined by files on the dynamic class path, removes all global variables and variables from the base workspace, and removes all compiled scripts, functions, and MEX-functions from memory.
  - To add folders to the static path, which MATLAB loads at startup, create a `javaclasspath.txt` file, as described in “The Static Path”.
  - MATLAB does not support JAR files generated by the MATLAB Builder for Java® product.

**Input Arguments** **dpath - Folder or JAR file**  
string | cell array of strings

Folder or JAR file, specified as a string or cell array of strings, to add to the dynamic path. When you add a folder to the path, MATLAB includes all files in that folder as part of the path.

**Data Types**  
char | cell

**Examples** **Add Folder to Dynamic Class Path**

Display the current dynamic path.

```
javaclasspath('-dynamic')
```

# javaaddpath

---

DYNAMIC JAVA PATH

```
<empty>
```

The output reflects your configuration.

Add the current folder.

```
javaaddpath(pwd)
```

Display the dynamic path.

```
p = javaclasspath
```

```
p =
 'c:\work\Java'
```

The output reflects your current folder.

## Append URL to Dynamic Class Path

```
javaaddpath('http://www.example.com', '-end')
p = javaclasspath
```

```
p =
 'c:\work\Java'
 'http://www.example.com'
```

## See Also

[javaclasspath](#) | [javarmpath](#) | [clear](#)

## Concepts

- “Bringing Java Classes into MATLAB Workspace”

<b>Purpose</b>	Construct Java array object
<b>Syntax</b>	<code>ObjArr = javaArray(PackageName.ClassName,x1,...,xN)</code>
<b>Description</b>	<code>ObjArr = javaArray(PackageName.ClassName,x1,...,xN)</code> constructs an empty Java array object for objects of the specified <code>PackageName.ClassName</code> class.
<b>Input Arguments</b>	<p><b>PackageName.ClassName - Name of Java class</b> string Name of Java class, including package name, specified as a string.</p> <p><b>Data Types</b> char</p> <p><b>x1,...,xN - Dimensions of the array</b> integer Dimensions of the array, specified as integer.</p> <p><b>Data Types</b> double</p>
<b>Output Arguments</b>	<p><b>ObjArr - Java array</b> Java array Java array with dimensions <code>x1, ..., xN</code>.</p>
<b>Definitions</b>	<p><b>Java Array Object</b> A Java array object is an object with Java dimensionality.</p>
<b>Tips</b>	<ul style="list-style-type: none"><li>The array created by <code>javaArray</code> is equivalent to the array created by the following Java code: <pre>A = new PackageName.ClassName[x1]...[xN];</pre></li></ul>

- To create an array of primitive Java types, create an array of the equivalent MATLAB type, shown in the Conversion of MATLAB Types to Java Types table. See “Conversion of MATLAB Argument Data”.

## Examples

### Create 4-By-5 Array

Create 4-by-5 array of `java.lang.Double` type.

```
x1 = 4; x2 = 5;
dblArray = javaArray ('java.lang.Double',x1,x2);
```

Fill in values.

```
for m = 1:x1
 for n = 1:x2
 dblArray(m,n) = java.lang.Double((m*10) + n);
 end
end
```

Display results.

```
dblArray
```

```
dblArray =
java.lang.Double[][]:
 [11] [12] [13] [14] [15]
 [21] [22] [23] [24] [25]
 [31] [32] [33] [34] [35]
 [41] [42] [43] [44] [45]
```

## See Also

[javaObjectEDT](#) | [javaMethodEDT](#) | [class](#) | [methodsview](#) | [isjava](#) |

## Concepts

- “Working with Java Arrays”



<b>Purpose</b>	Error message based on Java feature support								
<b>Syntax</b>	<pre>MSG = javachk(feature) javachk(feature,component)</pre>								
<b>Description</b>	<p>MSG = javachk(feature) returns a generic error message if the specified Java feature is not available in the current MATLAB session.</p> <p>javachk(feature,component) also names the specified component in the error message.</p>								
<b>Input Arguments</b>	<p><b>feature - Java feature</b> 'awt'   'desktop'   'jvm'   'swing'</p> <p>Java feature, specified as one of these values:</p> <table><tr><td>'awt'</td><td>Java GUI components in the Abstract Window Toolkit (AWT) components are available.</td></tr><tr><td>'desktop'</td><td>MATLAB interactive desktop is running.</td></tr><tr><td>'jvm'</td><td>Java Virtual Machine software (JVM™) is running.</td></tr><tr><td>'swing'</td><td>Swing components (Java lightweight GUI components in the Java Foundation Classes) are available.</td></tr></table> <p><b>component - Identifier</b> string</p> <p>Identifier, specified as a string, to display in the error message.</p> <p><b>Data Types</b> char</p>	'awt'	Java GUI components in the Abstract Window Toolkit (AWT) components are available.	'desktop'	MATLAB interactive desktop is running.	'jvm'	Java Virtual Machine software (JVM™) is running.	'swing'	Swing components (Java lightweight GUI components in the Java Foundation Classes) are available.
'awt'	Java GUI components in the Abstract Window Toolkit (AWT) components are available.								
'desktop'	MATLAB interactive desktop is running.								
'jvm'	Java Virtual Machine software (JVM™) is running.								
'swing'	Swing components (Java lightweight GUI components in the Java Foundation Classes) are available.								

## Output Arguments

### **MSG - Error message**

structure

Error message, returned as a structure with these fields:

If it is available, javachk returns an error structure with empty message and identifier fields.

### **message - Message**

string | empty

Message, specified as a string.

### **identifier - Identifier**

string | empty

Identifier, specified as a string.

## Examples

### **Generate Error**

```
if isempty(javachk('jvm'))
 scalar = java.lang.Double(5);
end
% Check that JVM is available & JavaFigures are supported
error(javachk('jvm'))
error(javachk('awt'))
```

### **Generate Error in User-Defined Script**

If you write a script, myFile, that displays a Java Frame and want it to error gracefully if a frame cannot be displayed, do the following:

```
error(javachk('awt','myFile'));
myFrame = java.awt.Frame;
myFrame.setVisible(1);
```

If the script cannot display a frame, it displays this error:

```
myFile is not supported on this platform.
```

**See Also**      usejava | error

# javaclasspath

---

**Purpose** Return Java class path or specify dynamic path

**Syntax**

```
javaclasspath
javaclasspath('-dynamic')
javaclasspath('-static')

dpath = javaclasspath
spath = javaclasspath('-static')
jpath = javaclasspath('-all')

javaclasspath(dpath)
javaclasspath(dpath1,dpath2)

javaclasspath(statusmsg)
```

**Description** javaclasspath displays the static and dynamic segments of the Java class path.

javaclasspath('-dynamic') displays the dynamic path.

javaclasspath('-static') displays the static path.

dpath = javaclasspath returns the dynamic path, dpath.

spath = javaclasspath('-static') returns the static path, spath.

jpath = javaclasspath('-all') returns the entire path, jpath. The returned cell array contains first the static segment of the path, and then the dynamic segment.

javaclasspath(dpath) changes the dynamic path to dpath. Use this syntax to reload Java classes.

`javaclasspath(dpath1,dpath2)` changes the dynamic path to the concatenation of paths `dpath1`, `dpath2`.

`javaclasspath(statusmsg)` enables or disables the display of status messages.

## Input Arguments

### **dpath - Path entries**

string | cell array of strings

Path entries, specified as a string or cell array of strings, to specify for the dynamic path. Converts relative paths to absolute paths.

**Example:** `javaclasspath('http://domain.com')`

### **Data Types**

char | cell

### **dpath1,dpath2 - Path entries**

string | cell array of strings

Path entries, specified as a string or cell array of strings, concatenated, to specify for the dynamic path.

### **Data Types**

char | cell

### **statusmsg - Message flag**

'-v0' (default) | '-v1'

Message flag, specified as one of these values:

- '-v0' Does not display status messages while loading the Java path from the file system.
- '-v1' Displays status messages.

Controls status message display from the `javaclasspath`, `javaaddpath`, and `javarmppath` functions.

# javaclasspath

---

## Output Arguments

### **dpath - Dynamic path entries**

cell array of strings

Dynamic path entries for the current path, returned as a cell array of strings. If no path entries are defined, `dpath` is an empty cell array.

### **spath - Static path entries**

cell array of strings

Static path entries for the current path, returned as a cell array of strings. If no path entries are defined, `spath` is an empty cell array.

### **jpath - All path entries**

cell array of strings

All path entries, returned as a cell array of strings. If no path entries are defined, `jpath` is an empty cell array.

## Tips

- MATLAB searches the static path before the dynamic path.
- Java classes on the static path should not have dependencies on classes on the dynamic path. Such dependencies produce run-time errors.
- MATLAB calls the `clear java` command whenever you change the dynamic path. This command clears the definitions of all Java classes defined by files on the dynamic class path, removes all global variables and variables from the base workspace, and removes all compiled scripts, functions, and MEX-functions from memory.
- MATLAB displays a warning if you add an entry to the dynamic path that is already specified on the static path.

## Definitions

### **Static Path**

The static path is a segment of the Java path which is loaded at the start of each MATLAB session from the MATLAB built-in Java path and the file `javaclasspath.txt`.

The static Java path offers better Java class-loading performance than the dynamic Java path. However, to modify the static Java path you

need to edit the file `javaclasspath.txt` and restart MATLAB. For more information, see “The Static Path”.

## Dynamic Path

The dynamic path is a segment of the Java path which is loaded any time during a MATLAB session using the `javaclasspath` function.

You can define the dynamic path (using `javaclasspath`), modify the path (using `javaaddpath` and `javarmppath`), and refresh the Java class definitions for all classes on the dynamic path (using `clear java`) without restarting MATLAB. For more information, see “The Dynamic Path”.

## Examples

### Modify Path Using Cell Array

Create a cell array with two path values.

```
dpath = {'http://domain.com','http://some.domain.com/jarfile.jar'};
```

Set message flag to display class-loading messages.

```
javaclasspath('-v1')
```

Modify path.

```
javaclasspath(dpath)
```

```
Loading following class path(s) from local file system:
```

```
* http://domain.com
```

```
* http://some.domain.com/jarfile.jar
```

Display updated dynamic path.

```
javaclasspath('-dynamic')
```

```
DYNAMIC JAVA PATH
```

```
http://domain.com
```

# javaclasspath

---

```
http://some.domain.com/jarfile.jar
```

MATLAB adds folders from `dpath` to the existing path.

## Capture Contents of Dynamic Path

Create a cell array, `p`, with the entries of the dynamic path.

```
javaclasspath('-v0') %Suppress display of class-loading messages
p = javaclasspath
```

```
p =
```

```
{}
[]
```

If there are no entries on the dynamic path, MATLAB creates an empty cell array.

## See Also

[javaaddpath](#) | [javarmpath](#) | [clear](#)

## Concepts

- “The Java Class Path”



<b>Purpose</b>	Capture error information for Java exception
<b>Description</b>	Process information from a <code>matlab.exception.JavaException</code> object to handle Java errors thrown from Java methods called from MATLAB. This class is derived from <code>MException</code> .
<b>Construction</b>	<code>e = matlab.exception.JavaException(msgID, errMsg, excObj)</code> constructs instance <code>e</code> of <code>matlab.exception.JavaException</code> class.
	<b>Input Arguments</b>
	<b>msgID</b> message identifier
	<b>errMsg</b> error message string
	<b>excObj</b> <code>java.lang.Throwable</code> object that caused the exception
	<b>Output Arguments</b>
	<b>e</b> Instance of <code>matlab.exception.JavaException</code> class
<b>Properties</b>	<b>ExceptionObject</b> Java exception object that caused the error.
<b>Tips</b>	<ul style="list-style-type: none"><li>You do not typically construct a <code>matlab.exception.JavaException</code> object explicitly. MATLAB automatically constructs a <code>JavaException</code> object whenever Java throws an exception. The <code>JavaException</code> object wraps the original Java exception.</li></ul>
<b>Copy Semantics</b>	Handle. To learn how handle classes affect copy operations, see Copying Objects in the MATLAB documentation.

# matlab.exception.JavaException

---

## Examples

```
try
 java.lang.Class.forName('foo');
catch e
 e.message
 if(isa(e, 'matlab.exception.JavaException'))
 ex = e.ExceptionObject;
 assert(isJava(ex));
 ex.printStackTrace;
 end
end
```

## Concepts

- “Capture Information About Exceptions”
- “Throw an Exception”

**Purpose**

Call Java method

**Syntax**

```
javaMethod(MethodName,JavaObj,x1,...,xN)
javaMethod(StaticMethodName,ClassName,x1,...,xN)
```

**Description**

javaMethod(MethodName,JavaObj,x1,...,xN) calls the method in the class of the Java object array with the signature matching the arguments x1,...,xN.

javaMethod(StaticMethodName,ClassName,x1,...,xN) calls the static method in class ClassName.

**Input Arguments****MethodName - Name of nonstatic Java method**

string

Name of nonstatic Java method, specified as a string.

**Data Types**

char

**JavaObj - Array**

Java object

Array, specified as a Java object of the class containing the method.

**x1,...,xN - Java method input arguments**

any type

Java method input arguments, 1 through N (if any), required by MethodName or StaticMethodName, specified by any type. The argument type is specified by the method argument list.

**StaticMethodName - Name of static Java method**

string

Name of static Java method, specified as a string.

**Data Types**

char

## **ClassName - Name of Java class**

string

Name of Java class, specified as a string, containing `StaticMethodName`.

## **Data Types**

char

## **Tips**

- In most cases, use either MATLAB or Java syntax to call methods on Java objects:

```
% MATLAB syntax
method(object,arg1,...,argn)
```

```
/* Java syntax */
object.method(arg1,...,argn)
```

- Use `javaMethod` to call methods having names that exceed the maximum length of a MATLAB identifier. (Call the `namelengthmax` function to obtain the maximum identifier length.)

This is the only way you can call such a method in MATLAB. For example, if you have the following function:

```
javaMethod('DataDefinitionAndDataManipulationTransactions',T);
```

- Use `javaMethod` when you want to specify the method name as a variable, to be invoked at runtime. When calling a static method, you also can use a variable in place of the class name argument. For example, see “Call Method Specified at Runtime” on page 1-3643.

## **Examples**

### **Call Method on Java Object**

Create a `java.util.Date` object, `myDate`, and change the month to 3.

```
myDate = java.util.Date;
javaMethod('setMonth',myDate,3);
```

## Call Static Method

Call `java.lang.Double` static method, `isNaN`, to test variable `num`.

```
num = 2.2;
if javaMethod('isNaN', 'java.lang.Double', num)
 disp('This is not a number')
end
```

Since `num` contains a number, no message is displayed.

## Call Method Specified at Runtime

This example, searching for a text pattern in a string, uses variables for the pattern and for the search method. These variables could be set at runtime from user input.

Choose method, `startsWith`, and identify pattern, `str`.

```
fnc = 'startsWith';
str = java.lang.String('Four score');
```

Identify text to search.

```
gAddress = java.lang.String('Four score and seven years ago');
```

Search `gAddress`.

```
javaMethod(fnc, gAddress, str)
```

```
ans =
 1
```

`gAddress` starts with the words `Four score`.

## See Also

[javaArray](#) | [javaObject](#) | [import](#) | [methods](#) | [isjava](#) | [javaMethodEDT](#) |

## Concepts

- “Calling Syntax”

# javaMethodEDT

---

## Purpose

Call Java method from Event Dispatch Thread (EDT)

## Syntax

```
javaMethodEDT(MethodName,JavaObj,x1,...,xN)
javaMethodEDT(StaticMethodName,ClassName,x1,...,xN)
```

## Description

javaMethodEDT(MethodName,JavaObj,x1,...,xN) calls the method in the class of the Java object array with the signature matching the arguments x1,...,xN from the Event Dispatch Thread (EDT)

javaMethodEDT(StaticMethodName,ClassName,x1,...,xN) calls the static method in class ClassName.

## Input Arguments

### **MethodName - Name of nonstatic Java method**

string

Name of nonstatic Java method, specified as a string.

### **Data Types**

char

### **JavaObj - Array**

Java object

Array, specified as a Java object of the class containing the method.

### **x1,...,xN - Java method input arguments**

any type

Java method input arguments, 1 through N (if any), required by MethodName or StaticMethodName, specified by any type. The argument type is specified by the method argument list.

### **StaticMethodName - Name of static Java method**

string

Name of static Java method, specified as a string.

### **Data Types**

char

**ClassName - Name of Java class**

string

Name of Java class, specified as a string, containing StaticMethodName.

**Data Types**

char

**Definitions****EDT**

The EDT is the Event Dispatch Thread, used in Java.

**Examples****Call Method from EDT**

Create a `java.util.Vector` object, `v`, and add a string element.

```
v = java.util.Vector;
javaMethodEDT('add',v,'string');
```

**See Also**

[javaMethod](#) | [javaObjectEDT](#) | [import](#) | [methods](#) | [isjava](#)

# javaObject

---

<b>Purpose</b>	Call Java constructor
<b>Syntax</b>	<code>JavaObj = javaObject(ClassName,x1,...,xN)</code>
<b>Description</b>	<code>JavaObj = javaObject(ClassName,x1,...,xN)</code> returns Java object array, <code>JavaObj</code> , created by the Java constructor for the class with the argument list matching <code>x1, . . . ,xN</code> .
<b>Input Arguments</b>	<p><b>ClassName - Name of Java class</b> string Name of Java class, specified as a string.</p> <p><b>Data Types</b> char</p> <p><b>x1,...,xN - Java constructor input arguments</b> any type Java constructor input arguments, 1 through N (if any), required by <code>ClassName</code>, specified by any type. The argument type is specified by the class constructor argument list.</p>
<b>Examples</b>	<p><b>Create Java Object</b></p> <p>Create a Java object, <code>strObj</code>, of class <code>java.lang.String</code>.</p> <pre>strObj = javaObject('java.lang.String','hello');</pre>
<b>See Also</b>	<code>javaArray</code>   <code>javaMethod</code>   <code>import</code>   <code>methods</code>   <code>javaObjectEDT</code>
<b>Concepts</b>	<ul style="list-style-type: none"><li>“Using the <code>javaObjectEDT</code> Function”</li></ul>



<b>Purpose</b>	Call Java constructor on Event Dispatch Thread (EDT)
<b>Syntax</b>	<code>JavaObj = javaObjectEDT(ClassName,x1,...,xN)</code>
<b>Description</b>	<code>JavaObj = javaObjectEDT(ClassName,x1,...,xN)</code> returns Java object array, <code>JavaObj</code> , created from the EDT by the Java constructor for the class with the signature matching the arguments <code>x1, ..., xN</code> .
<b>Input Arguments</b>	<p><b>ClassName - Name of Java class</b> string Name of Java class, specified as a string.</p> <p><b>Data Types</b> char</p> <p><b>x1,...,xN - Java constructor input arguments</b> any type Java constructor input arguments, 1 through N (if any), required by <code>ClassName</code>, specified by any type. The argument type is specified by the class constructor argument list.</p>
<b>Tips</b>	<ul style="list-style-type: none"><li>• MATLAB calls methods on <code>JavaObj</code> from the EDT.</li><li>• Static methods on the specified class or Java object run on the MATLAB thread unless called using the <code>javaMethodEDT</code> function.</li></ul>
<b>Definitions</b>	<p><b>EDT</b> The EDT is the Event Dispatch Thread, used in Java.</p>
<b>Examples</b>	<p><b>Construct Java Object Array from the EDT</b></p> <pre>f = javaObjectEDT('javax.swing.JFrame','New Title');</pre> <p><b>Call Method on Java Object</b></p> <p>Create a <code>JOptionPane</code> on the EDT.</p>

# javaObjectEDT

---

```
optPane = javaObjectEDT('javax.swing.JOptionPane');
```

Call the `createDialog` method on the EDT.

```
dlg = optPane.createDialog([], 'Sample Dialog');
```

## See Also

[javaMethodEDT](#) | [javaObject](#) | [import](#) | [methods](#)

<b>Purpose</b>	Remove entries from dynamic Java class path
<b>Syntax</b>	<code>javarmpath(dpath1,...,dpathN)</code>
<b>Description</b>	<code>javarmpath(dpath1,...,dpathN)</code> removes one or more files or folders from the current dynamic class path.
<b>Input Arguments</b>	<b>dpath1,...,dpathN - Folders or JAR files</b> <i>string</i> Folders or JAR files, specified as strings, to remove from path. <b>Data Types</b> <i>char</i>
<b>Tips</b>	<ul style="list-style-type: none"><li>• MATLAB calls the <code>clear java</code> command whenever you change the dynamic path. This command clears the definitions of all Java classes defined by files on the dynamic class path, removes all global variables and variables from the base workspace, and removes all compiled scripts, functions, and MEX-functions from memory.</li></ul>
<b>Examples</b>	<b>Remove Folder from Dynamic Path</b> In order to preserve the state of the dynamic path on your system, this example first adds folders to the path, then removes one of these folders. Create a variable that points to the MATLAB examples folder. <pre>expath = fullfile(matlabroot,'extern','examples')  expath =  C:\Program Files\MATLAB\R2012b\extern\examples</pre> The path reflects the folder to your MATLAB installation. Add two folders to the path. <pre>javaclasspath({...</pre>

# javarmpath

---

```
 expath,...
 'http://www.example.com'})
javaclasspath('-dynamic')
```

```
DYNAMIC JAVA PATH
```

```
C:\Program Files\MATLAB\R2012b\extern\examples
http://www.example.com
```

The output displays these new folders on your existing path.

Remove one folder.

```
javarmpath(expath)
javaclasspath('-dynamic')
```

```
DYNAMIC JAVA PATH
```

```
http://www.example.com
```

The path no longer contains the examples folder.

## See Also

## Functions

javaclasspath javaaddpath clear

## Concepts

- “Bringing Java Classes into MATLAB Workspace”

**Purpose**

Merge two tables by matching up rows using key variables

**Syntax**

```
C = join(A,B)
C = join(A,B,Name,Value)
[C,ib] = join(___)
```

**Description**

`C = join(A,B)` merges tables `A` and `B` by matching up rows using all the variables with the same name as key variables. The key values must be common to both `A` and `B`, except for order.

`join` retains all the variables from `A` and appends the corresponding contents from the nonkey variables of `B`.

`C = join(A,B,Name,Value)` joins the tables with additional options specified by one or more `Name,Value` pair arguments.

For example, you can specify the variables to use as key variables.

`[C,ib] = join( ___ )` also returns an index vector, `ib`, such that each element of `ib` identifies the row in `B` that corresponds to that row in the output table, `C`. You can use this syntax with any of the input arguments of the previous syntaxes.

**Input Arguments****A,B - Input tables**

tables

Input tables, specified as tables. For all key variables, each row of `A` must match exactly one row in `B`.

**Name-Value Pair Arguments**

Specify optional comma-separated pairs of `Name,Value` arguments. `Name` is the argument name and `Value` is the corresponding value. `Name` must appear inside single quotes ( ' ' ). You can specify several name and value pair arguments in any order as `Name1,Value1,...,NameN,ValueN`.

**Example:** 'Keys', 2 uses the second variable in A and the second variable in B as key variables.

## **'Keys' - Variables to use as keys**

positive integer | vector of positive integers | variable name | cell array of variable names | logical vector | 'RowNames'

Variables to use as keys, specified as the comma-separated pair consisting of 'Keys' and a positive integer, vector of positive integers, variable name, cell array of variable names, logical vector, or 'RowNames'.

If you specify the string 'RowNames', then `join` uses the row names of A and row names of B as keys. In this case, there must be a row in B for every row in A.

You cannot use the 'Keys' name-value pair argument with the 'LeftKeys' and 'RightKeys' name-value pair arguments.

**Example:** 'Keys', [1 3] uses the first and third variables from A and B as a key variables.

## **'LeftKeys' - Variables to use as keys in A**

positive integer | vector of positive integers | variable name | cell array of variable names | logical vector

Variables to use as keys in A, specified as the comma-separated pair consisting of 'LeftKeys' and a positive integer, vector of positive integers, variable name, cell array of variable names, or logical vector.

You must use the 'LeftKeys' name-value pair argument in conjunction with the 'RightKeys' name-value pair argument. 'LeftKeys' and 'RightKeys' both must specify the same number of key variables. `join` pairs key values based on their order.

**Example:** 'LeftKeys', 1 uses only the first variable in A as a key variable.

## **'RightKeys' - Variables to use as keys in B**

positive integer | vector of positive integers | variable name | cell array of variable names | logical vector

Variables to use as keys in **B**, specified as the comma-separated pair consisting of `'RightKeys'` and a positive integer, vector of positive integers, variable name, cell array of variable names, or logical vector.

You must use the `'RightKeys'` name-value pair argument in conjunction with the `'LeftKeys'` name-value pair argument. `'LeftKeys'` and `'RightKeys'` both must specify the same number of key variables. `join` pairs values in **A** and **B** based on their order.

**Example:** `'RightKeys',3` uses only the third variable in **B** as a key variable.

#### **'LeftVariables' - Variables from A to include in C**

positive integer | vector of positive integers | variable name | cell array containing one or more variable names | logical vector

Variables from **A** to include in **C**, specified as the comma-separated pair consisting of `'LeftVariables'` and a positive integer, vector of positive integers, variable name, cell array of variable names, or logical vector.

You can use `'LeftVariables'` to include or exclude key variables, as well as nonkey variables from the output, **C**.

By default, `join` includes all variables from **A**.

#### **'RightVariables' - Variables from B to include in C**

positive integer | vector of positive integers | variable name | cell array containing one or more variable names | logical vector

Variables from **B** to include in **C**, specified as the comma-separated pair consisting of `'RightVariables'` and a positive integer, vector of positive integers, variable name, cell array of variable names, or logical vector.

You can use `'RightVariables'` to include or exclude key variables, as well as nonkey variables from the output, **C**.

By default, `join` includes all the variables from **B** except the key variables.

## **'KeepOneCopy' - Variables for which join retains only the copy from A**

variable name | cell array containing one or more variable names

Variables for which `join` retains only the copy from A, specified as the comma-separated pair consisting of `'KeepOneCopy'` and a variable name or a cell array containing one or more variable names.

Key variables appear once in C, but if nonkey variables with identical names occur in A and B, then `join` retains both copies in C by default. You must use the `'KeepOneCopy'` name-value pair to retain only the copy from A.

**Example:** `'KeepOneCopy',Var2` keeps only the copy from A of the nonkey variable `Var2`.

## **Output Arguments**

### **C - Merged data from A and B**

table

Merged data from A and B, returned as a table. The table, C, contains one row for each row in A, appearing in the same order. If A and B contain nonkey variables with the same name, `join` adds a unique suffix to the corresponding variable names in C, unless you specify the `'KeepOneCopy'` name-value pair argument.

`join` creates C by horizontally concatenating `A(:,LeftVars)` and `B(ib,RightVars)`. By default, `LeftVars` is all the variables of A, and `RightVars` is all the nonkey variables from B. Otherwise, `LeftVars` consists of the variables specified by the `'LeftVariables'` name-value pair argument, and `RightVars` consists of the variables specified by the `'RightVariables'` name-value pair argument.

You can store additional metadata such as descriptions, variable units, variable names, and row names in the output table, C. For more information, see [Table Properties](#).

### **ib - Index to B**

column vector



Index to B, returned as a column vector. Each element of `ib` identifies the row in B that corresponds to that row in the output table, C.

## Definitions

### Key Variable

Variable used to match and combine data between the input tables, A and B.

### Key Value

Entry in a key variable of A.

## Algorithms

The `join` function first finds one or more key variables. Then, `join` uses the key variables to find the row in input table B that matches each row in input table A, and combines those rows to create a row in output table C.

- If there is a one-to-one mapping between key values in A and B, then `join` sorts the data in B and appends it to table A.
- If there is a many-to-one mapping between key values in A and B, then `join` sorts and repeats the data in B before appending it to table A.
- If there is data in a key variable of B that does not map to a key value in A, then `join` does not include that data in the output table, C.

## Examples

### Append Values from One Table to Another

Create a table, A.

```
A = table({'John','Jane','Jim','Jerry','Jill'},[1;2;1;2;1],...
 'VariableNames',{'Employee' 'Department'})
```

A =

Employee	Department
'John'	1
'Jane'	2

# join

---

```
'Jim' 1
'Jerry' 2
'Jill' 1
```

Create a table, B, with a variable in common with A.

```
B = table([1 2], {'Mary' 'Mike'}, ...
 'VariableNames', {'Department' 'Manager'})
```

B =

Department	Manager
1	'Mary'
2	'Mike'

Create a new table, C, containing data from tables A and B. Use the `join` function to repeat and append Manager data from table B to the data from table A based on the key variable, Department.

```
C = join(A,B)
```

C =

Employee	Department	Manager
'John'	1	'Mary'
'Jane'	2	'Mike'
'Jim'	1	'Mary'
'Jerry'	2	'Mike'
'Jill'	1	'Mary'

## Merge Tables with One Variable in Common

Create a table, A.

```
A = table([5;12;23;2;6], ...
```

```
{'cereal';'pizza';'salmon';'cookies';'pizza'},...
'VariableNames',{ 'Age', 'FavoriteFood'},...
'RowNames',{ 'Amy', 'Bobby', 'Holly', 'Harry', 'Sally'})
```

A =

	Age	FavoriteFood
Amy	5	'cereal'
Bobby	12	'pizza'
Holly	23	'salmon'
Harry	2	'cookies'
Sally	6	'pizza'

Create a table, B, with one variable in common with A.

```
B = table({'cereal';'cookies';'pizza';'salmon';'cake'},...
[110;160;140;367;243],...
{'B';'D';'B-';'A';'C-'},...
'VariableNames',{'FavoriteFood','Calories','NutritionGrade'})
```

B =

FavoriteFood	Calories	NutritionGrade
'cereal'	110	'B'
'cookies'	160	'D'
'pizza'	140	'B-'
'salmon'	367	'A'
'cake'	243	'C-'

Create a new table, C, with data from tables A and B. Use FavoriteFood as a key variable to the join function.

```
C = join(A,B)
```

C =

	Age	FavoriteFood	Calories	NutritionGrade
Amy	5	'cereal'	110	'B'
Bobby	12	'pizza'	140	'B-'
Holly	23	'salmon'	367	'A'
Harry	2	'cookies'	160	'D'
Sally	6	'pizza'	140	'B-'

Table C does not include information from the last row of table B about 'cake' since there is no corresponding entry in table A.

## Merge Tables by Specifying One Key Variable

Create a table, A.

```
A = table([10;4;2;3;7],[5;4;9;6;1],[10;3;8;8;4])
```

A =

Var1	Var2	Var3
10	5	10
4	4	3
2	9	8
3	6	8
7	1	4

Create a table, B, giving Var2 the same contents as Var2 from table A.

```
B = table([6;1;1;6;8],[5;4;9;6;1])
```

B =

Var1	Var2
------	------

6	5
1	4
1	9
6	6
8	1

Create a new table, C, containing data from tables A and B. Use Var1 in table A and Var2 in table B as key variables to the join function.

```
C = join(A,B, 'Keys', 'Var2')
```

C =

Var1_A	Var2	Var3	Var1_B
10	5	10	6
4	4	3	1
2	9	8	1
3	6	8	6
7	1	4	8

join adds a unique suffix to the nonkey variable Var1 to distinguish the data from tables A and B.

### Keep One Copy of Nonkey Variables

Create a new table with data from tables A and B. If any nonkey variables have the same name in both tables, keep only the copy from table A.

Create a table, A.

```
A = table([10;4;2;3;7],[5;4;9;6;1])
```

A =

# join

---

Var1	Var2
10	5
4	4
2	9
3	6
7	1

Create a table, B, giving Var2 the same contents as Var2 from table A.

```
B = table([6;1;1;6;8],[5;4;9;6;1],[10;3;8;8;4])
```

B =

Var1	Var2	Var3
6	5	10
1	4	3
1	9	8
6	6	8
8	1	4

Create a new table, C, with data from tables A and B. Use Var2 as a key variable to the join function and keep only the copy of Var1 from table A.

```
C = join(A,B,'Keys','Var2','KeepOneCopy','Var1')
```

C =

Var1	Var2	Var3
10	5	10
4	4	3
2	9	8

```

 3 6 8
 7 1 4

```

C does not contain the Var1 data from table B.

### Merge Tables Using Row Names as Keys

Create a table, A.

```

A = table(['M';'M';'F';'F';'F'],[38;43;38;40;49],...
 'VariableNames',{'Gender' 'Age'},...
 'RowNames',{'Smith' 'Johnson' 'Williams' 'Jones' 'Brown'})

```

A =

	Gender	Age
	-----	-----
Smith	M	38
Johnson	M	43
Williams	F	38
Jones	F	40
Brown	F	49

Create a table, B, such that there is a one-to-one correspondence between the rows of A and the rows of B.

```

B = table([64;69;67;71;64],...
 [119;163;133;176;131],...
 [122 80; 109 77; 117 75; 124 93; 125 83],...
 'VariableNames',{'Height' 'Weight' 'BloodPressure'},...
 'RowNames',{'Brown' 'Johnson' 'Jones' 'Smith' 'Williams'})

```

B =

Height	Weight	BloodPressure
-----	-----	-----

# join

---

Brown	64	119	122	80
Johnson	69	163	109	77
Jones	67	133	117	75
Smith	71	176	124	93
Williams	64	131	125	83

Create a new table, C, with data from tables A and B. Use the row names as keys to the join function.

```
C = join(A,B, 'Keys', 'RowNames')
```

```
C =
```

	Gender	Age	Height	Weight	BloodPressure	
Smith	M	38	71	176	124	93
Johnson	M	43	69	163	109	77
Williams	F	38	64	131	125	83
Jones	F	40	67	133	117	75
Brown	F	49	64	119	122	80

The rows of C are in the same order as A.

## Merge Tables Using Left and Right Keys

Create a table, A.

```
A = table([10;4;2;3;7],[5;4;9;6;1],[10;3;8;8;4])
```

```
A =
```

Var1	Var2	Var3
10	5	10
4	4	3
2	9	8
3	6	8



7      1      4

Create a table, B, giving Var2 the same contents as Var1 from table A, except for order.

```
B = table([6;1;1;6;8],[2;3;4;7;10])
```

B =

Var1	Var2
-----	-----
6	2
1	3
1	4
6	7
8	10

Create a new table, C, containing data from tables A and B. Use Var1 from table A with Var2 from table B as key variables to the join function.

```
[C,ib] = join(A,B,'LeftKeys',1,'RightKeys',2)
```

C =

Var1_A	Var2	Var3	Var1_B
-----	-----	-----	-----
10	5	10	8
4	4	3	1
2	9	8	6
3	6	8	1
7	1	4	6

ib =

5

# join

---

3  
1  
2  
4

C is the horizontal concatenation of A and B (ib, 2).

## See Also

`innerjoin` | `outerjoin`

**Purpose** Input from keyboard

**Syntax** keyboard

**Description** keyboard , when placed in a program .m file, stops execution of the file and gives control to the keyboard. The special status is indicated by a K appearing before the prompt. You can examine or change variables; all MATLAB commands are valid. This keyboard mode is useful for debugging your functions.

To terminate the keyboard mode, type return, and then press **Enter**. To terminate keyboard mode and exit the function, type dbquit, and press **Enter**.

**See Also** dbstop | input | quit | pause | return

# containers.Map.keys

---

**Purpose** Identify keys of containers.Map object

**Syntax** `keySet = keys(mapObj)`

**Description** `keySet = keys(mapObj)` returns cell array `keySet`, which contains all of the keys in `mapObj`.

**Input Arguments** **mapObj**  
Object of class `containers.Map`.

**Output Arguments** **keySet**  
1-by-n cell array, where n is the number of keys in `mapObj`.

## Examples **Get the Keys in a Map**

Create a map, and view the keys in the map:

```
myKeys = {'a','b','c'};
myValues = [1,2,3];
mapObj = containers.Map(myKeys,myValues);
```

```
keySet = keys(mapObj)
```

This code returns 1-by-3 cell array `keySet`:

```
keySet =
 'a' 'b' 'c'
```

**See Also** `containers.Map` | `isKey` | `values` | `remove`

<b>Purpose</b>	Kronecker tensor product																
<b>Syntax</b>	<code>K = kron(A,B)</code>																
<b>Description</b>	<code>K = kron(A,B)</code> returns the Kronecker tensor product of matrices A and B. If A is an m-by-n matrix and B is a p-by-q matrix, then <code>kron(A,B)</code> is an m*p-by-n*q matrix formed by taking all possible products between the elements of A and the matrix B.																
<b>Input Arguments</b>	<p><b>A,B - Input matrices</b> scalars   vectors   matrices</p> <p>Input matrices, specified as scalars, vectors, or matrices. If either A or B is sparse, then <code>kron</code> multiplies only nonzero elements and the result is also sparse.</p> <p><b>Data Types</b> single   double   int8   int16   int32   int64   uint8   uint16   uint32   uint64   logical</p> <p><b>Complex Number Support:</b> Yes</p>																
<b>Examples</b>	<p><b>Block Diagonal Matrix</b></p> <p>Create a block diagonal matrix.</p> <p>Create a 4-by-4 identity matrix and a 2-by-2 matrix that you want to be repeated along the diagonal.</p> <pre>A = eye(4); B = [1 -1;-1 1];</pre> <p>Use <code>kron</code> to find the Kronecker tensor product.</p> <pre>K = kron(A,B)</pre> <pre>K =</pre> <table style="margin-left: 40px;"> <tr> <td>1</td><td>-1</td><td>0</td><td>0</td><td>0</td><td>0</td><td>0</td><td>0</td> </tr> <tr> <td>-1</td><td>1</td><td>0</td><td>0</td><td>0</td><td>0</td><td>0</td><td>0</td> </tr> </table>	1	-1	0	0	0	0	0	0	-1	1	0	0	0	0	0	0
1	-1	0	0	0	0	0	0										
-1	1	0	0	0	0	0	0										

```
0 0 1 -1 0 0 0 0
0 0 -1 1 0 0 0 0
0 0 0 0 1 -1 0 0
0 0 0 0 -1 1 0 0
0 0 0 0 0 0 1 -1
0 0 0 0 0 0 -1 1
```

The result is an 8-by-8 block diagonal matrix.

## Repeat Matrix Elements

Expand the size of a matrix by repeating elements.

Create a 2-by-2 matrix of ones and a 2-by-3 matrix whose elements you want to repeat.

```
A = [1 2 3; 4 5 6];
B = ones(2);
```

Calculate the Kronecker tensor product using `kron`.

```
K = kron(A,B)
```

```
K =
```

```
1 1 2 2 3 3
1 1 2 2 3 3
4 4 5 5 6 6
4 4 5 5 6 6
```

The result is a 4-by-6 block matrix.

## Sparse Laplacian Operator Matrix

This example visualizes a sparse Laplacian operator matrix.

The matrix representation of the discrete Laplacian operator on a two-dimensional,  $n$ -by- $n$  grid is a  $n*n$ -by- $n*n$  sparse matrix. There are at most five nonzero elements in each row or column. You can generate

the matrix as the Kronecker product of one-dimensional difference operators. In this example  $n = 5$ .

```
n = 5;
I = speye(n,n);
E = sparse(2:n,1:n-1,1,n,n);
D = E+E' - 2*I;
A = kron(D,I)+kron(I,D);
```

Visualize the sparsity pattern with `spy`.

```
spy(A, 'k')
```

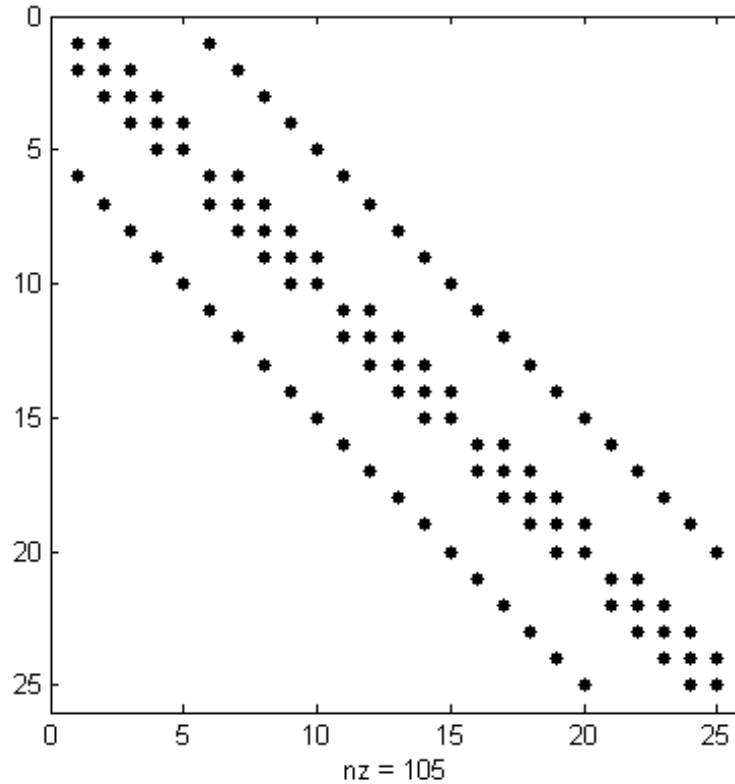

## Definitions **Kronecker Tensor Product**

If  $A$  is an  $m$ -by- $n$  matrix and  $B$  is a  $p$ -by- $q$  matrix, then the Kronecker tensor product of  $A$  and  $B$  is a large matrix formed by multiplying  $B$  by each element of  $A$



$$A \otimes B = \begin{bmatrix} a_{11}B & a_{12}B & \cdots & a_{1n}B \\ a_{21}B & a_{22}B & \cdots & a_{2n}B \\ \vdots & \vdots & \ddots & \vdots \\ a_{m1}B & a_{m2}B & \cdots & a_{mn}B \end{bmatrix}.$$

For example, two simple 2-by-2 matrices produce

$$A = \begin{bmatrix} 1 & -2 \\ -1 & 0 \end{bmatrix}, \quad B = \begin{bmatrix} 4 & -3 \\ 2 & 3 \end{bmatrix}$$

$$A \otimes B = \begin{bmatrix} 1 \square 4 & 1 \square -3 & -2 \square 4 & -2 \square -3 \\ 1 \square 2 & 1 \square 3 & -2 \square 2 & -2 \square 3 \\ -1 \square 4 & -1 \square -3 & 0 \square 4 & 0 \square -3 \\ -1 \square 2 & -1 \square 3 & 0 \square 2 & 0 \square 3 \end{bmatrix} = \begin{bmatrix} 4 & -3 & -8 & 6 \\ 2 & 3 & -4 & -6 \\ -4 & 3 & 0 & 0 \\ -2 & -3 & 0 & 0 \end{bmatrix}.$$

## See Also

[hankel](#) | [toeplitz](#) | [dot](#) | [cross](#)

# last (MException)

---

**Purpose** Last uncaught exception

**Syntax** `exception = MException.last`  
`MException.last('reset')`

**Description** `exception = MException.last` displays the contents of the MException object representing your most recent uncaught error. This is a static method of the MException class; it is not a method of an MException instance.

---

**Note** Use this method from the MATLAB command line only, and not within a function.

---

`MException.last('reset')` sets the `identifier` and `message` properties of the exception retrieved by `MException.last` to the empty string, the `stack` property to a 0-by-1 structure, and `cause` property to an empty cell array.

`MException.last` is not set if an exception is caught by a `try, catch` statement.

**Examples** This example displays the last error that was caught during this MATLAB session:

```
A = 25;
A(2)
??? Index exceeds matrix dimensions.
```

```
MException.last
ans =
```

MException object with properties:

```
 identifier: 'MATLAB:badsubscript'
 message: 'Index exceeds matrix dimensions.'
```

```
stack: [0x1 struct]
cause: {}
```

### See Also

```
addCause(MException) | throwAsCaller(MException)
| rethrow(MException) | throw(MException) |
getReport(MException) | MException | assert | error |
try, catch
```

# Tiff.lastDirectory

---

**Purpose** Determine if current IFD is last in file

**Syntax** `bool = tiffobj.lastDirectory()`

**Description** `bool = tiffobj.lastDirectory()` returns true if the current image file directory (IFD) is the last IFD in the TIFF file; otherwise, false. If the file contains only one image, the current IFD is the last.

**Examples**      **Determine if Current Directory is the Last Directory**

Open a Tiff object and determine if the current directory is the last directory in the file.

```
t = Tiff('example.tif', 'r');
tf = t.lastDirectory()
```

```
tf =
```

```
0
```

The current directory is not the last directory in the file.

Close the Tiff object.

```
t.close();
```

**References** This method corresponds to the `TIFFLastDirectory` function in the LibTIFF C API. To use this method, you must be familiar with the TIFF specification and technical notes. View this documentation at [LibTIFF - TIFF Library and Utilities](#).

**See Also** `Tiff.setDirectory`

**Tutorials**

- “Exporting Image Data and Metadata to TIFF Files”
- “Reading Image Data and Metadata from TIFF Files”

**Purpose** Last error message

---

**Note** `lasterr` will be removed in a future version. You can obtain information about any error that has been generated by catching an `MException`. See “Capture Information About Exceptions” in the Programming Fundamentals documentation.

---

**Syntax**

```
msgstr = lasterr
[msgstr, msgid] = lasterr
lasterr('new_msgstr')
lasterr('new_msgstr', 'new_msgid')
[msgstr, msgid] = lasterr('new_msgstr', 'new_msgid')
```

**Description** `msgstr = lasterr` returns the last error message generated by the MATLAB software.

`[msgstr, msgid] = lasterr` returns the last error in `msgstr` and its message identifier in `msgid`. If the error was not defined with an identifier, `lasterr` returns an empty string for `msgid`. See “Message Identifiers” in the MATLAB Programming Fundamentals documentation for more information on the `msgid` argument and how to use it.

`lasterr('new_msgstr')` sets the last error message to a new string, `new_msgstr`, so that subsequent invocations of `lasterr` return the new error message string. You can also set the last error to an empty string with `lasterr('')`.

`lasterr('new_msgstr', 'new_msgid')` sets the last error message and its identifier to new strings `new_msgstr` and `new_msgid`, respectively. Subsequent invocations of `lasterr` return the new error message and message identifier.

`[msgstr, msgid] = lasterr('new_msgstr', 'new_msgid')` returns the last error message and its identifier, also changing these values so that subsequent invocations of `lasterr` return the message and identifier strings specified by `new_msgstr` and `new_msgid` respectively.

## Examples

### Example 1

Here is a function that examines the `lasterr` string and displays its own message based on the error that last occurred. This example deals with two cases, each of which is an error that can result from a matrix multiply:

```
function matrix_multiply(A, B)
try
 A * B
catch
 errmsg = lasterr;
 if(strfind(errmsg, 'Inner matrix dimensions'))
 disp('** Wrong dimensions for matrix multiply')
 else
 if(strfind(errmsg, 'not defined for variables of class'))
 disp('** Both arguments must be double matrices')
 end
 end
end
end
```

If you call this function with matrices that are incompatible for matrix multiplication (e.g., the column dimension of A is not equal to the row dimension of B), MATLAB catches the error and uses `lasterr` to determine its source:

```
A = [1 2 3; 6 7 2; 0 -1 5];
B = [9 5 6; 0 4 9];
```

```
matrix_multiply(A, B)
** Wrong dimensions for matrix multiply
```

### Example 2

Specify a message identifier and error message string with `error`:

```
error('MyToolbox:angleTooLarge', ...
 'The angle specified must be less than 90 degrees.');
```

In your error handling code, use `lasterr` to determine the message identifier and error message string for the failing operation:

```
[errmsg, msgid] = lasterr
errmsg =
 The angle specified must be less than 90 degrees.
msgid =
 MyToolbox:angleTooLarge
```

## See Also

[error](#) | [lasterror](#) | [rethrow](#) | [warning](#) | [lastwarn](#)

# lasterror

---

## Purpose

Last error message and related information

---

**Note** `lasterror` will be removed in a future version. You can obtain information about any error that has been generated by catching an `MException`. See “Capture Information About Exceptions” in the Programming Fundamentals documentation.

---

## Syntax

```
s = lasterror
s = lasterror(err)
s = lasterror('reset')
```

## Description

`s = lasterror` returns a structure `s` containing information about the most recent error issued by the MATLAB software. The return structure contains the following fields:

Fieldname	Description
message	Character array containing the text of the error message.
identifier	Character array containing the message identifier of the error message. If the last error issued by MATLAB had no message identifier, then the <code>identifier</code> field is an empty character array.
stack	Structure providing information on the location of the error. The structure has fields <code>file</code> , <code>name</code> , and <code>line</code> , and is the same as the structure returned by the <code>dbstack</code> function. If <code>lasterror</code> returns no stack information, <code>stack</code> is a 0-by-1 structure having the same three fields.

---

**Note** The `lasterror` return structure might contain additional fields in future versions of MATLAB.

---



The fields of the structure returned in `stack` are

Fieldname	Description
<code>file</code>	Name of the file in which the function generating the error appears. This field is the empty string if there is no file.
<code>name</code>	Name of the function in which the error occurred. If this is the primary function in the file, and the function name differs from the file name, <code>name</code> is set to the file name.
<code>line</code>	Line number of the file at which the error occurred.

See “Message Identifiers” in the MATLAB Programming Fundamentals documentation for more information on the syntax and usage of message identifiers.

`s = lasterror(err)` sets the last error information to the error message and identifier specified in the structure `err`. Subsequent invocations of `lasterror` return this new error information. The optional return structure `s` contains information on the previous error.

`s = lasterror('reset')` sets the last error information to the default state. In this state, the `message` and `identifier` fields of the return structure are empty strings, and the `stack` field is a 0-by-1 structure.

## Tips

MathWorks is gradually transitioning MATLAB error handling to an object-oriented scheme that is based on the `MException` class. Although support for `lasterror` is expected to continue, using the static `last` method of `MException` is preferable.

## Warning

**`lasterror` and `MException.last` are not guaranteed to always return identical results. For example, `MException.last` updates its error status only on uncaught errors, where `lasterror` can update its error status on any error, whether it is caught or not.**

## Examples

### Example 1

Save the following MATLAB code in a file called `average.m`:

```
function y = average(x)
% AVERAGE Mean of vector elements.
% AVERAGE(X), where X is a vector, is the mean of vector elements.
% Nonvector input results in an error.
check_inputs(x)
y = sum(x)/length(x); % The actual computation

function check_inputs(x)
[m,n] = size(x);
if (~((m == 1) || (n == 1)) || (m == 1 && n == 1))
 error('AVG:NotAVector', 'Input must be a vector.')
end
```

Now run the function. Because this function requires vector input, passing a scalar value to it forces an error. The error occurs in subroutine `check_inputs`:

```
average(200)
Error using average>check_inputs (line 11)
Input must be a vector.
```

```
Error in average (line 5)
check_inputs(x)
```

Get the three fields from `lasterror`:

```
err = lasterror
err =
 message: [1x61 char]
 identifier: 'AVG:NotAVector'
 stack: [2x1 struct]
```

Display the text of the error message:

```
msg = err.message
```

```
msg =
 Error using average>check_inputs (line 11)
 Input must be a vector.
```

Display the fields containing the stack information. `err.stack` is a 2-by-1 structure because it provides information on the failing subroutine `check_inputs` and also the outer, primary function `average`:

```
st1 = err.stack(1,1)
st1 =
 file: 'd:\matlab_test\average.m'
 name: 'check_inputs'
 line: 11

st2 = err.stack(2,1)
st2 =
 file: 'd:\matlab_test\average.m'
 name: 'average'
 line: 5
```

---

**Note** As a rule, the name of your primary function should be the same as the name of the file that contains that function. If these names differ, MATLAB uses the file name in the `name` field of the `stack` structure.

---

## Example 2

`lasterror` is often used in conjunction with the `rethrow` function in `try`, `catch` statements. For example,

```
try
 do_something
catch
 do_cleanup
 rethrow(lasterror)
end
```

# lasterror

---

## See Also

dbstack | lastwarn | rethrow | assert | error | MException |  
last(MException) | try, catch

<b>Purpose</b>	Last warning message
<b>Syntax</b>	<pre>msgstr = lastwarn [msgstr, msgid] = lastwarn lastwarn('new_msgstr') lastwarn('new_msgstr', 'new_msgid') [msgstr, msgid] = lastwarn('new_msgstr', 'new_msgid')</pre>
<b>Description</b>	<p><code>msgstr = lastwarn</code> returns the last warning message generated by the MATLAB software.</p> <p><code>[msgstr, msgid] = lastwarn</code> returns the last warning in <code>msgstr</code> and its message identifier in <code>msgid</code>. If the warning was not defined with an identifier, <code>lastwarn</code> returns an empty string for <code>msgid</code>.</p> <p><code>lastwarn('new_msgstr')</code> sets the last warning message to a new string, <code>new_msgstr</code>, so that subsequent invocations of <code>lastwarn</code> return the new warning message string. You can also set the last warning to an empty string with <code>lastwarn('')</code>.</p> <p><code>lastwarn('new_msgstr', 'new_msgid')</code> sets the last warning message and its identifier to new strings <code>new_msgstr</code> and <code>new_msgid</code>, respectively. Subsequent invocations of <code>lastwarn</code> return the new warning message and message identifier.</p> <p><code>[msgstr, msgid] = lastwarn('new_msgstr', 'new_msgid')</code> returns the last warning message and its identifier, also changing these values so that subsequent invocations of <code>lastwarn</code> return the message and identifier strings specified by <code>new_msgstr</code> and <code>new_msgid</code>, respectively.</p>
<b>Tips</b>	<p><code>lastwarn</code> does not return warnings that are reported during the parsing of MATLAB commands. (Warning messages that include the failing file name and line number are parse-time warnings.)</p>
<b>Examples</b>	<p>Write a short function that generates a warning message. At the start of the function, enable any warnings that have a message identifier called <code>TestEnv:InvalidInput</code>:</p>

# lastwarn

---

```
function myfun(p1)
warning on TestEnv:InvalidInput;

exceedMax = find(p1 > 5000);
if any(exceedMax)
 warning('TestEnv:InvalidInput', ...
 '%d values in the "%s" array exceed the maximum.', ...
 length(exceedMax), inputname(1))
end
```

Pass an invalid value to the function:

```
dataIn = magic(10) - 2;

myfun(dataIn)
Warning: 2 values in the "dataIn" array exceed the maximum.
> In myfun at 4
```

Use lastwarn to determine the message identifier and error message string for the operation:

```
[warnmsg, msgid] = lastwarn
warnmsg =
 2 values in the "dataIn" array exceed the maximum.
msgid =
 TestEnv:InvalidInput
```

## See Also

warning | error

## Related Examples

- “Issue Warnings and Errors”
- “Suppress Warnings”
- “Restore Warnings”

<b>Purpose</b>	Least common multiple
<b>Syntax</b>	$L = \text{lcm}(A,B)$
<b>Description</b>	$L = \text{lcm}(A,B)$ returns the least common multiples of the elements of A and B.
<b>Input Arguments</b>	<p><b>A,B - Input values</b>  scalars, vectors, or arrays of real, positive integer values</p> <p>Input values, specified as scalars, vectors, or arrays of real, positive integer values. A and B can be any numeric type, and they can be of different types within certain limitations:</p> <ul style="list-style-type: none"> <li>• If A or B is of type <code>single</code>, then the other can be of type <code>single</code> or <code>double</code>.</li> <li>• If A or B belongs to an integer class, then the other must belong to the same class or it must be a <code>double</code> scalar value.</li> </ul> <p>A and B must be the same size or one must be a scalar.</p> <p><b>Example:</b> <code>[20 3 13],[10 6 7]</code></p> <p><b>Example:</b> <code>int16([100 30 200]),int16([20 15 9])</code></p> <p><b>Example:</b> <code>int16([100 30 200]),20</code></p> <p><b>Data Types</b>  <code>single</code>   <code>double</code>   <code>int8</code>   <code>int16</code>   <code>int32</code>   <code>int64</code>   <code>uint8</code>   <code>uint16</code>   <code>uint32</code>   <code>uint64</code></p>
<b>Output Arguments</b>	<p><b>L - Least common multiple</b>  real, positive integer values</p> <p>Least common multiple, returned as an array of real positive integer values. L is the same size as A and B, and it has the same type as A and B. If A and B are of different types, then L is returned as the <code>nondouble</code> type.</p>

## Examples

### Least Common Multiples of Double Array and a Scalar

```
A = [5 17; 10 60];
B = 45;
L = lcm(A,B)
```

```
L =
```

```
 45 765
 90 180
```

### Least Common Multiples of Unsigned Integers

```
A = uint16([255 511 15]);
B = uint16([15 127 1023]);
L = lcm(A,B)
```

```
L =
```

```
 255 64897 5115
```

## See Also

[gcd](#)



**Purpose**

Block LDL' factorization for Hermitian indefinite matrices

**Syntax**

```
L = ldl(A)
[L,D] = ldl(A)
[L,D,P] = ldl(A)
[L,D,p] = ldl(A, 'vector')
[U,D,P] = ldl(A, 'upper')
[U,D,p] = ldl(A, 'upper', 'vector')
[L,D,P,S] = ldl(A)
[L,D,P,S] = LDL(A, THRESH)
[U,D,p,S] = LDL(A, THRESH, 'upper', 'vector')
```

**Description**

`L = ldl(A)` returns only the "psychologically lower triangular matrix" `L` as in the two-output form. The permutation information is lost, as is the block diagonal factor `D`. By default, `ldl` references only the diagonal and lower triangle of `A`, and assumes that the upper triangle is the complex conjugate transpose of the lower triangle. Therefore `[L,D,P] = ldl(TRIL(A))` and `[L,D,P] = ldl(A)` both return the exact same factors. Note, this syntax is not valid for sparse `A`.

`[L,D] = ldl(A)` stores a block diagonal matrix `D` and a "psychologically lower triangular matrix" (i.e a product of unit lower triangular and permutation matrices) in `L` such that  $A = L * D * L'$ . The block diagonal matrix `D` has 1-by-1 and 2-by-2 blocks on its diagonal. Note, this syntax is not valid for sparse `A`.

`[L,D,P] = ldl(A)` returns unit lower triangular matrix `L`, block diagonal `D`, and permutation matrix `P` such that  $P' * A * P = L * D * L'$ . This is equivalent to `[L,D,P] = ldl(A, 'matrix')`.

`[L,D,p] = ldl(A, 'vector')` returns the permutation information as a vector, `p`, instead of a matrix. The `p` output is a row vector such that  $A(p,p) = L * D * L'$ .

`[U,D,P] = ldl(A, 'upper')` references only the diagonal and upper triangle of `A` and assumes that the lower triangle is the complex conjugate transpose of the upper triangle. This syntax returns a unit upper triangular matrix `U` such that  $P' * A * P = U' * D * U$  (assuming that

A is Hermitian, and not just upper triangular). Similarly,  $[L,D,P] = \text{ldl}(A, 'lower')$  gives the default behavior.

$[U,D,p] = \text{ldl}(A, 'upper', 'vector')$  returns the permutation information as a vector,  $p$ , as does  $[L,D,p] = \text{ldl}(A, 'lower', 'vector')$ .  $A$  must be a full matrix.

$[L,D,P,S] = \text{ldl}(A)$  returns unit lower triangular matrix  $L$ , block diagonal  $D$ , permutation matrix  $P$ , and scaling matrix  $S$  such that  $P' * S * A * S * P = L * D * L'$ . This syntax is only available for real sparse matrices, and only the lower triangle of  $A$  is referenced. `ldl` uses MA57 for sparse real symmetric  $A$ .

$[L,D,P,S] = \text{LDL}(A, \text{THRESH})$  uses `THRESH` as the pivot tolerance in MA57. `THRESH` must be a double scalar lying in the interval  $[0, 0.5]$ . The default value for `THRESH` is 0.01. Using smaller values of `THRESH` may give faster factorization times and fewer entries, but may also result in a less stable factorization. This syntax is available only for real sparse matrices.

$[U,D,p,S] = \text{LDL}(A, \text{THRESH}, 'upper', 'vector')$  sets the pivot tolerance and returns upper triangular  $U$  and permutation vector  $p$  as described above.

## Examples

These examples illustrate the use of the various forms of the `ldl` function, including the one-, two-, and three-output form, and the use of the `vector` and `upper` options. The topics covered are:

- “Example 1 — Two-Output Form of `ldl`” on page 1-3689
- “Example 2 — Three Output Form of `ldl`” on page 1-3689
- “Example 3 — The Structure of  $D$ ” on page 1-3690
- “Example 4 — Using the `'vector'` Option” on page 1-3690
- “Example 5 — Using the `'upper'` Option” on page 1-3691
- “Example 6 — `linsolve` and the Hermitian indefinite solver” on page 1-3691

Before running any of these examples, you will need to generate the following positive definite and indefinite Hermitian matrices:

```
A = full(delsq(numgrid('L', 10)));
B = gallery('uniformdata',10,0);
M = [eye(10) B; B' zeros(10)];
```

The structure of  $M$  here is very common in optimization and fluid-flow problems, and  $M$  is in fact indefinite. Note that the positive definite matrix  $A$  must be full, as `ldl` does not accept sparse arguments.

### Example 1 – Two-Output Form of `ldl`

The two-output form of `ldl` returns  $L$  and  $D$  such that  $A - (L^*D^*L')$  is small,  $L$  is "psychologically unit lower triangular" (i.e., a permuted unit lower triangular matrix), and  $D$  is a block 2-by-2 diagonal. Note also that, because  $A$  is positive definite, the diagonal of  $D$  is all positive:

```
[LA,DA] = ldl(A);
fprintf(1, ...
'The factorization error ||A - LA*DA*LA' || is %g\n', ...
norm(A - LA*DA*LA'));
neginds = find(diag(DA) < 0)
```

Given a  $b$ , solve  $Ax=b$  using  $LA$ ,  $DA$ :

```
bA = sum(A,2);
x = LA' \ (DA \ (LA \ bA));
fprintf(...
'The absolute error norm ||x - ones(size(bA)) || is %g\n', ...
norm(x - ones(size(bA))));
```

### Example 2 – Three Output Form of `ldl`

The three output form returns the permutation matrix as well, so that  $L$  is in fact unit lower triangular:

```
[Lm, Dm, Pm] = ldl(M);
fprintf(1, ...
'The error norm ||Pm'*M*Pm - Lm*Dm*Lm' || is %g\n', ...
```

```
norm(Pm'*M*Pm - Lm*Dm*Lm'));
fprintf(1, ...
'The difference between Lm and tril(Lm) is %g\n', ...
norm(Lm - tril(Lm)));
```

Given  $b$ , solve  $Mx=b$  using  $Lm$ ,  $Dm$ , and  $Pm$ :

```
bM = sum(M,2);
x = Pm*(Lm'\(Dm\(Lm*(Pm'*bM))));
fprintf(...
'The absolute error norm ||x - ones(size(b))|| is %g\n', ...
norm(x - ones(size(bM))));
```

### Example 3 – The Structure of D

$D$  is a block diagonal matrix with 1-by-1 blocks and 2-by-2 blocks. That makes it a special case of a tridiagonal matrix. When the input matrix is positive definite,  $D$  is almost always diagonal (depending on how definite the matrix is). When the matrix is indefinite however,  $D$  may be diagonal or it may express the block structure. For example, with  $A$  as above,  $DA$  is diagonal. But if you shift  $A$  just a bit, you end up with an indefinite matrix, and then you can compute a  $D$  that has the block structure.

```
figure; spy(DA); title('Structure of D from ldl(A)');
[Las, Das] = ldl(A - 4*eye(size(A)));
figure; spy(Das);
title('Structure of D from ldl(A - 4*eye(size(A)))');
```

### Example 4 – Using the 'vector' Option

Like the `lu` function, `ldl` accepts an argument that determines whether the function returns a permutation vector or permutation matrix. `ldl` returns the latter by default. When you select 'vector', the function executes faster and uses less memory. For this reason, specifying the 'vector' option is recommended. Another thing to note is that indexing is typically faster than multiplying for this kind of operation:

```
[Lm, Dm, pm] = ldl(M, 'vector');
```

```

fprintf(1, 'The error norm ||M(pm,pm) - Lm*Dm*Lm'|| is %g\n', ...
 norm(M(pm,pm) - Lm*Dm*Lm'));

% Solve a system with this kind of factorization.
clear x;
x(pm,:) = Lm'\(Dm\(Lm\(bM(pm,:)));
fprintf('The absolute error norm ||x - ones(size(b))|| is %g\n', ...
 norm(x - ones(size(bM))));

```

### Example 5 – Using the 'upper' Option

Like the `chol` function, `ldl` accepts an argument that determines which triangle of the input matrix is referenced, and also whether `ldl` returns a lower (L) or upper (L') triangular factor. For dense matrices, there are no real savings with using the upper triangular version instead of the lower triangular version:

```

M1 = tril(M);
[Lm1, Dm1, Pm1] = ldl(M1, 'lower'); % 'lower' is default behavior.
fprintf(1, ...
 'The difference between Lm1 and Lm is %g\n', norm(Lm1 - Lm));
[Umu, Dmu, pmu] = ldl(triu(M), 'upper', 'vector');
fprintf(1, ...
 'The difference between Umu and Lm'' is %g\n', norm(Umu - Lm'));

% Solve a system using this factorization.
clear x;
x(pm,:) = Umu\(Dmu\(Umu'\(bM(pmu,:)));
fprintf(...
 'The absolute error norm ||x - ones(size(b))|| is %g\n', ...
 norm(x - ones(size(bM))));

```

When specifying both the 'upper' and 'vector' options, 'upper' must precede 'vector' in the argument list.

### Example 6 – `linsolve` and the Hermitian indefinite solver

When using the `linsolve` function, you may experience better performance by exploiting the knowledge that a system has a symmetric

matrix. The matrices used in the examples above are a bit small to see this so, for this example, generate a larger matrix. The matrix here is symmetric positive definite, and below we will see that with each bit of knowledge about the matrix, there is a corresponding speedup. That is, the symmetric solver is faster than the general solver while the symmetric positive definite solver is faster than the symmetric solver:

```
Abig = full(delsq(numgrid('L', 30)));
bbig = sum(Abig, 2);
LSopts.POSDEF = false;
LSopts.SYM = false;
tic; linsolve(Abig, bbig, LSopts); toc;
LSopts.SYM = true;
tic; linsolve(Abig, bbig, LSopts); toc;
LSopts.POSDEF = true;
tic; linsolve(Abig, bbig, LSopts); toc;
```

## Algorithms

ldl uses the MA57 routines in the Harwell Subroutine Library (HSL) for real sparse matrices.

## References

- [1] Ashcraft, C., R.G. Grimes, and J.G. Lewis. "Accurate Symmetric Indefinite Linear Equations Solvers." *SIAM J. Matrix Anal. Appl.* Vol. 20. Number 2, 1998, pp. 513–561.
- [2] Duff, I. S. "MA57 — A new code for the solution of sparse symmetric definite and indefinite systems." Technical Report RAL-TR-2002-024, Rutherford Appleton Laboratory, 2002.

## See Also

chol | lu | qr

**Purpose** Left array division

**Syntax**  
`x = B.\A`  
`x = ldivide(B,A)`

**Description** `x = B.\A` divides each element of `A` by the corresponding element of `B`.

- If `A` and `B` are arrays, then they must be the same size.
- If either `A` or `B` is a scalar, then MATLAB expands the scalar value into an appropriately sized array.

`x = ldivide(B,A)` is an alternative way to divide `A` by `B`, but is rarely used. It enables operator overloading for classes.

## Input Arguments

### A - Numerator

numeric array | sparse numeric array

Numerator, specified as a full or sparse numeric array. If `B` is an integer data type, then `A` must be the same integer type or a scalar double.

#### Data Types

single | double | int8 | int16 | int32 | int64 | uint8 | uint16 | uint32 | uint64

**Complex Number Support:** Yes

### B - Denominator

numeric array | sparse numeric array

Denominator, specified as a full or sparse numeric array. If `A` is an integer data type, then `B` must be the same integer type or a scalar double.

#### Data Types

single | double | int8 | int16 | int32 | int64 | uint8 | uint16 | uint32 | uint64

**Complex Number Support:** Yes

# ldivide, .\

---

## Output Arguments

### x - Solution

numeric array | sparse numeric array

Solution, returned as a sparse or full numeric array. If either A or B are integer data types, then x is that same integer data type.

## Examples

### Divide Two Numeric Arrays

```
A = ones(2, 3);
B = [1 2 3; 4 5 6];
x = B.\A
```

x =

```
 1.0000 0.5000 0.3333
 0.2500 0.2000 0.1667
```

### Divide a Scalar by a Numeric Array

```
C = 2;
D = [1 2 3; 4 5 6];
x = D.\C
```

x =

```
 2.0000 1.0000 0.6667
 0.5000 0.4000 0.3333
```

## Tips

- MATLAB does not support complex integer division.

## See Also

[rdivide](#) | [mldivide](#) | [mrdivide](#)



---

<b>Purpose</b>	Determine less than or equal to
<b>Syntax</b>	A <= B le(A,B)
<b>Description</b>	<p>A &lt;= B returns a logical array with elements set to logical 1 (true) where A is less than or equal to B; otherwise, it returns logical 0 (false). The test compares only the real part of numeric arrays. le returns logical 0 (false) where A or B have NaN or undefined categorical elements.</p> <p>le(A,B) is an alternate way to execute A &lt;= B, but is rarely used. It enables operator overloading for classes.</p>
<b>Input Arguments</b>	<p><b>A - Left array</b> numeric array   logical array   character array   ordinal categorical array</p> <p>Left array, specified as a numeric array, logical array, character array, or categorical array. Inputs A and B must be the same size unless one is a scalar. A scalar input expands into an array of the same size as the other input.</p> <p>If one input is an ordinal categorical array, the other input can be an ordinal categorical array, a cell array of strings, or a single string. A single string expands into a cell array of strings of the same size as the other input. If both inputs are ordinal categorical arrays, they must have the same sets of categories, including their order. See “Compare Categorical Array Elements” for more details.</p> <p><b>B - Right array</b> numeric array   logical array   character array   ordinal categorical array</p> <p>Right array, specified as a numeric array, logical array, character array, or categorical array. Inputs A and B must be the same size unless one</p>

is a scalar. A scalar input expands into an array of the same size as the other input.

If one input is an ordinal categorical array, the other input can be an ordinal categorical array, a cell array of strings, or a single string. A single string expands into a cell array of strings of the same size as the other input. If both inputs are ordinal categorical arrays, they must have the same sets of categories, including their order. See “Compare Categorical Array Elements” for more details.

## Examples

### Test Vector Elements

Find which vector elements are less than or equal to a given value.

Create a numeric vector.

```
A = [1 12 18 7 9 11 2 15];
```

Test the vector for elements that are less than or equal to 12.

```
A <= 12
```

```
ans =
```

```
 1 1 0 1 1 1 1 0
```

The result is a vector with values of logical 1 (true) where the elements of A satisfy the expression.

Use the vector of logical values as an index to view the values in A that are less than or equal to 12.

```
A(A <= 12)
```

```
ans =
```

```
 1 12 7 9 11 2
```

The result is a subset of the elements in A.

## Replace Elements of Matrix

Create a matrix.

```
A = magic(4)
```

```
A =
```

```

 16 2 3 13
 5 11 10 8
 9 7 6 12
 4 14 15 1

```

Replace all values less than or equal to 9 with the value 10.

```
A(A <= 9) = 10
```

```
A =
```

```

 16 10 10 13
 10 11 10 10
 10 10 10 12
 10 14 15 10

```

The result is a new matrix whose smallest element is 10.

## Compare Values in Categorical Array

Create an ordinal categorical array.

```
A = categorical({'large' 'medium' 'small'; 'medium' ...
 'small' 'large'},{'small' 'medium' 'large'},'Ordinal',1)
```

```
A =
```

```

 large medium small
 medium small large

```

The array has three categories: 'small', 'medium', and 'large'.

Find all values less than or equal to the category 'medium'.

```
A <= 'medium'
```

```
ans =
```

```
 0 1 1
 1 1 0
```

A value of logical 1 (true) indicates a value less than or equal to the category 'medium'.

Compare the rows of A.

```
A(1,:) <= A(2,:)
```

```
ans =
```

```
 0 0 1
```

The function returns logical 1 (true) where the first row has a category value less than or equal to the second row.

## Test Complex Numbers

Create a vector of complex numbers.

```
A = [1+i 2-2i 1+3i 1-2i 5-i];
```

Find the values that are less than or equal to 3.

```
A(A <= 3)
```

```
ans =
```

```
1.0000 + 1.0000i 2.0000 - 2.0000i 1.0000 + 3.0000i 1.0000 - 2.0000i
```

le compares only the real part of the elements in A.

Use abs to find which elements are within a radius of 3 from the origin.

```
A(abs(A) <= 3)
```

```
ans =
```

```
1.0000 + 1.0000i 2.0000 - 2.0000i 1.0000 - 2.0000i
```

The result has one less element. The element  $1.0000 + 3.0000i$  is not within a radius of 3 from the origin.

**Tips**

- Some floating-point numbers cannot be represented exactly in binary form. This leads to small differences in results that the `<=` operator reflects. For more information, see “Avoiding Common Problems with Floating-Point Arithmetic”.

**See Also**

`eq` | `ge` | `gt` | `lt` | `ne`

**Concepts**

- “Ordinal Categorical Arrays”

# legend

---

## Purpose

Graph legend for lines and patches

## Syntax

```
legend('string1','string2',...)
legend(h,'string1','string2',...)
legend(M)
legend(h,M)
legend(M,'parameter_name','parameter_value',...)
legend(h,M,'parameter_name','parameter_value',...)
legend(axes_handle,...)
legend('off')
legend(axes_handle,'off')
legend('toggle')
legend(axes_handle,'toggle')
legend('hide')
legend(axes_handle,'hide')
legend('show')
legend(axes_handle,'show')
legend('boxoff')
legend(axes_handle,'boxoff')
legend('boxon')
legend(axes_handle,'boxon')
legend_handle = legend(...)
legend(...,'Location','location')
legend(...,'Orientation','orientation')
[legend_h,object_h,plot_h,text_strings] = legend(...)
```

## Description

The legend function places a legend on various types of graphs (line plots, bar graphs, pie charts, etc.). For each line plotted, the legend shows a sample of the line type, marker symbol, and color beside the text label you specify. When plotting filled areas (patch or surface objects), the legend contains a sample of the face color next to the text label.

The font size and font name for the legend strings match the axes `FontSize` and `FontName` properties.

`legend('string1','string2',...)` displays a legend in the current axes using the specified strings to label each set of data.

`legend(h, 'string1', 'string2', ...)` displays a legend on the plot containing the objects identified by the handles in the vector `h` and uses the specified strings to label the corresponding graphics object (line, barseries, etc.).

`legend(M)` adds a legend containing the rows of the matrix or cell array of strings `M` as labels. For matrices, this is the same as `legend(M(1,:), M(2,:), ...)`.

`legend(h, M)` associates each row of the matrix or cell array of strings `M` with the corresponding graphics object (patch or line) in the vector of handles `h`.

`legend(M, 'parameter_name', 'parameter_value', ...)` and `legend(h, M, 'parameter_name', 'parameter_value', ...)` allow parameter/value pairs to be set when creating a legend (you can also assign them with `set` or with the Property Editor or Property Inspector). `M` must be a cell array of names. Legends inherit the properties of axes, although not all of them are relevant to legend objects.

`legend(axes_handle, ...)` displays the legend for the axes specified by `axes_handle`.

`legend('off')` removes the legend in the current axes.

`legend(axes_handle, 'off')` removes the legend in the axes specified by `axes_handle`.

`legend('toggle')` toggles the legend visibility. If a legend does not exist, then one is created using default strings. If a legend exists, then toggling its state to invisible does not remove the legend.

`legend(axes_handle, 'toggle')` toggles the legend visibility in the axes specified by `axes_handle`.

The *default string* for an object is the value of the object's `DisplayName` property, if you have defined a value for `DisplayName` (which you can do using the Property Editor or calling `set`). Otherwise, `legend` constructs a string of the form `data1, data2, etc.` Setting display names is useful when you are experimenting with legends and might forget how objects in a lineseries, for example, are ordered.

# legend

---

When you specify legend strings in a `legend` command, their respective `DisplayNames` are set to these strings. If you delete a legend and then create a new legend without specifying labels for it, the values of `DisplayName` are (re)used as label names. Naturally, the associated plot objects must have a `DisplayName` property for this to happen: all `_series` and `_group` plot objects have a `DisplayName` property; Handle Graphics primitives, such as `line` and `patch`, do not.

Legends for graphs that contain groups of objects such as `lineseries`, `barseries`, `contourgroups`, etc. created by high-level plotting commands such as `plot`, `bar`, `contour`, etc., by default display a single legend entry for the entire group, regardless of how many member objects it contains. However, you can customize such legends to show individual entries for all or selected member objects and assign a unique `DisplayName` to any of them. You control how groups appear in the legend by setting values for their `Annotation` and `DisplayName` properties with code. For information and examples about customizing legends in this manner, see “Control Legend Content” in the MATLAB Graphics documentation.

You can specify `EdgeColor` and `TextColor` as RGB triplets or as `ColorSpecs`. You cannot set these colors to `'none'`. To hide the box surrounding a legend, set the `Box` property to `'off'`. To allow the background to show through the legend box, set the legend's `Color` property to `'none'`, for example,

```
set(legend_handle, 'Box', 'off')
set(legend_handle, 'Color', 'none')
```

This is similar to the effect of the command `legend boxoff`, except that `boxoff` also hides the legend's border.

You can use a legend's handle to set text properties for all the strings in a legend at once with a cell array of strings, rather than looping through each of them. See the last line of the example below, which demonstrates setting a legend's `Interpreter` property. In that example, you could reset the `String` property of the legend as follows:

```
set(h, 'String', {'cos(x)', 'sin(x)'})
```



See the documentation for Text Properties for additional details.

`legend('hide')` makes the legend in the current axes invisible.

`legend(axes_handle, 'hide')` makes the legend in the axes specified by `axes_handle` invisible.

`legend('show')` makes the legend in the current axes visible. A legend is created if one did not exist previously. Legends created automatically are limited to depict only the first 20 lines in the plot; if you need more legend entries, you can manually create a legend for them all with `legend('string1', 'string2', ...)` syntax.

`legend(axes_handle, 'show')` makes the legend in the axes specified by `axes_handle` visible.

`legend('boxoff')` removes the box from the legend in the current axes and makes its background transparent.

`legend(axes_handle, 'boxoff')` removes the box from the legend in the axes specified by `axes_handle` and makes its background transparent.

`legend('boxon')` adds a box with an opaque background to the legend in the current axes.

`legend(axes_handle, 'boxon')` adds a box with an opaque background to the legend in the axes specified by `axes_handle`.

You can also type the above six commands using the syntax

`legend keyword`

If the keyword is not recognized, it is used as legend text, creating a legend or replacing the current legend.

`legend_handle = legend(...)` returns the handle to the legend on the current axes, or `[]` if no legend exists.

`legend(..., 'Location', 'location')` uses *location* to determine where to place the legend. *location* can be either be a 1-by-4 position vector (`[left, bottom, width, height]`) or one of the following strings.

# legend

---

<b>Specifier</b>	<b>Location in Axes</b>
North	Inside plot box near top
South	Inside bottom
East	Inside right
West	Inside left
NorthEast	Inside top right (default for 2-D plots)
NorthWest	Inside top left
SouthEast	Inside bottom right
SouthWest	Inside bottom left
NorthOutside	Outside plot box near top
SouthOutside	Outside bottom
EastOutside	Outside right
WestOutside	Outside left
NorthEastOutside	Outside top right (default for 3-D plots)
NorthWestOutside	Outside top left
SouthEastOutside	Outside bottom right
SouthWestOutside	Outside bottom left
Best	Least conflict with data in plot
BestOutside	Least unused space outside plot

Using one of the `...Outside` values for `'Location'` ensures that the legend does not overlap the plot, whereas overlaps can occur when you specify any of the other cardinal values. The `location` property applies to colorbars and legends, but not to axes.

**Note** You can set the legend location by passing the 4-element position vector to the `legend` function using the `'Location'` option. To define the position of an existing legend, use the `set` function to assign the 4-element position vector to the `'Position'` property. You cannot use the `Location` option with the `set` function.

## Obsolete Location Values

The first column of the following table shows the now-obsolete specifiers for legend locations that were in use prior to Version 7, along with a description of the locations and their current equivalent syntaxes.

**Note** Support for these numeric specifiers will be removed in a future release. Use the supported string specifiers instead.

Obsolete Specifier	Location in Axes	Current Specifier
-1	Outside axes on right side	NorthEastOutside
0	Inside axes	Best
1	Upper right corner of axes	NorthEast
2	Upper left corner of axes	NorthWest
3	Lower left corner of axes	SouthWest
4	Lower right corner of axes	SouthEast

`legend(..., 'Orientation', 'orientation')` creates a legend with the legend items arranged in the specified orientation. *orientation* can be `vertical` (the default) or `horizontal`.

`[legend_h, object_h, plot_h, text_strings] = legend(...)` returns

- `legend_h` — Handle of the legend axes

# legend

---

- `object_h` — Handles of the line, patch, and text graphics objects used in the legend
- `plot_h` — Handles of the lines and other objects used in the plot
- `text_strings` — Cell array of the text strings used in the legend

## Relationship to Axes

`legend` associates strings with the objects in the axes in the same order that they are listed in the axes `Children` property. By default, the legend annotates the current axes.

You can only display one legend per axes. `legend` positions the legend based on a variety of factors, such as what objects the legend obscures.

The properties that legends do not share with axes are

- `Location`
- `Orientation`
- `EdgeColor`
- `TextColor`
- `Interpreter`
- `String`

## Tips

### Using Keywords as Legend Labels

To use legend keywords like `'Location'`, `'Orientation'`, `'Off'`, `'Hide'`, or property names as legend labels, pass the string in a cell array to the `legend` function as,

```
l = legend({'Location'});
```

## Examples

Add a legend to a graph showing a sine and cosine function. The default location is upper right, within the axes:

```
figure
x = -pi:pi/20:pi;
plot(x,cos(x),'-ro',x,sin(x),'-.b')
```

```
hleg1 = legend('cos_x', 'sin_x');
```

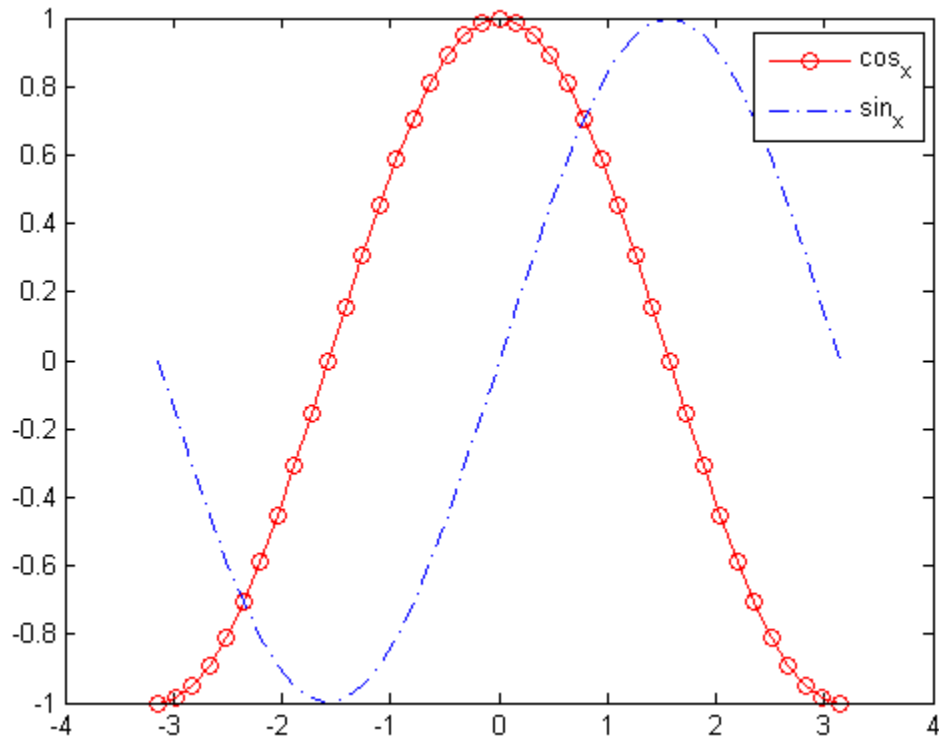

The legend reflects that `plot` specified a solid, red line ('-ro') for the cosine function and a dash-dot, blue line ('-.b') for the sine function.

Update the legend. Use the returned legend handle, `hleg1`, to move the legend to the upper left. Also turn off the TeX interpreter to render underscores in legend text literally rather than as subscripts:

```
set(hleg1, 'Location', 'NorthWest')
set(hleg1, 'Interpreter', 'none')
```

# legend

---

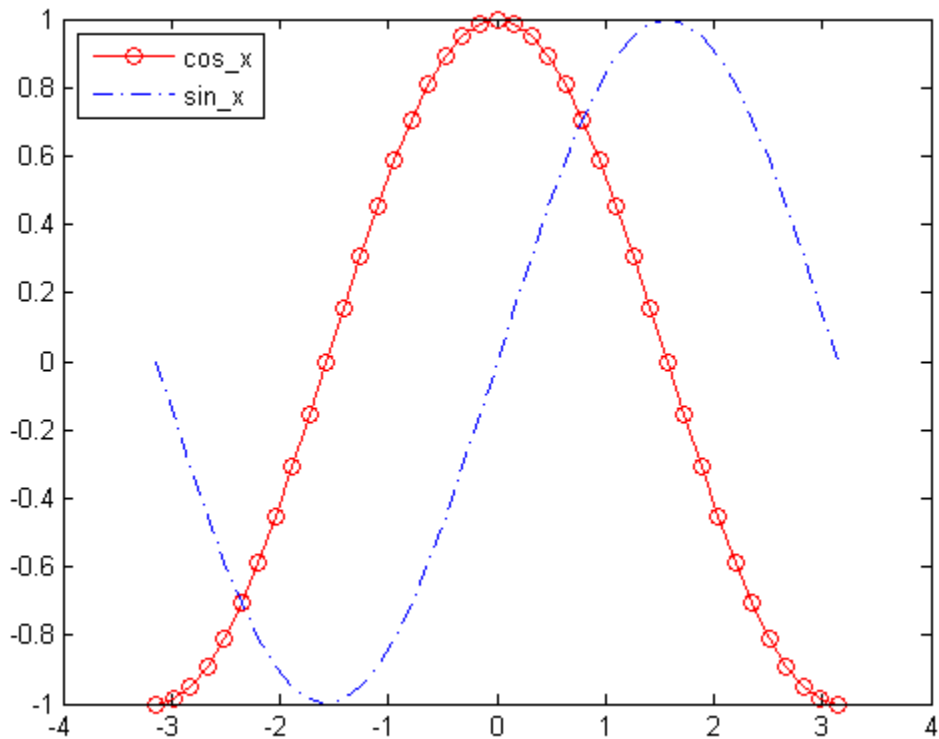

---

Setting the position of the legend at a particular position.

```
set(hleg1, 'Position', [.1,.2,.1,.2]);
```

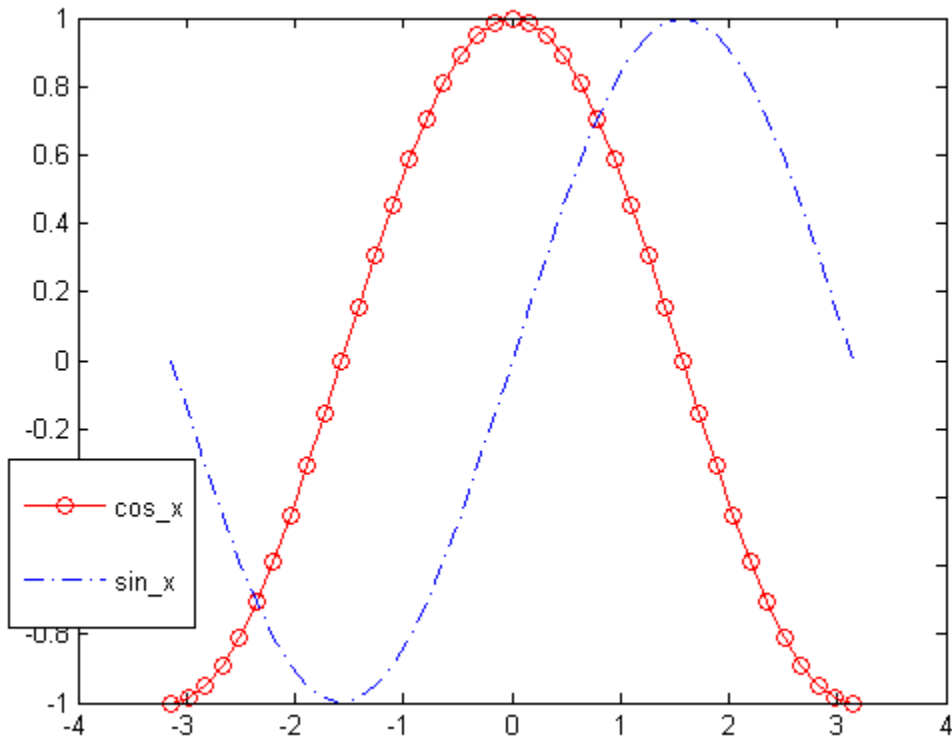

Use `besselj` to plot Bessel functions for orders 1, 2, and 3. Add a legend for the lines at the upper right, outside the axes.

```
figure
x = 0:.2:12;
plot(x,besselj(1,x),x,besselj(2,x),x,besselj(3,x));
hleg = legend('First','Second','Third',...
 'Location','NorthEastOutside')
% Make the text of the legend italic and color it brown
```

# legend

---

```
set(hleg,'FontAngle','italic','TextColor',[.3,.2,.1])
```

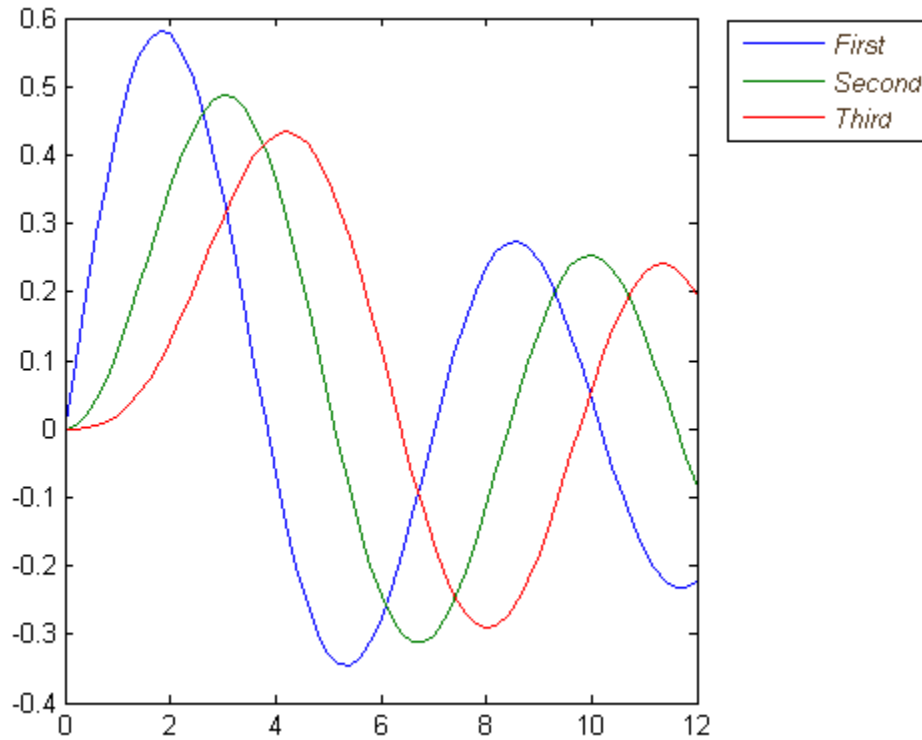

---

Create a bar graph and overlay a line plot on it by setting `hold` on. Create a legend that reflects both graphs and locate it to the lower right, outside the axes:

```
figure
stream = RandStream('mrg32k3a','Seed',4);
y1 = rand(stream,10,5);
```



```
hb = bar(y1, 'stacked');
colormap(summer);

hold on
y2 = rand(stream,10,1);
hp = plot(1:10,y2,...
 'marker', 'square',...
 'markersize', 12,...
 'markeredgecolor', 'y',...
 'markerfacecolor', [.6,0,.6],...
 'linestyle', '- ',...
 'color', 'r',...
 'linewidth', 2);
hold off
legend([hb,hp], 'Carrots', 'Peas', 'Peppers', 'Green Beans',...
 'Cucumbers', 'Eggplant',...
 'Location', 'SouthEastOutside')
```

# legend

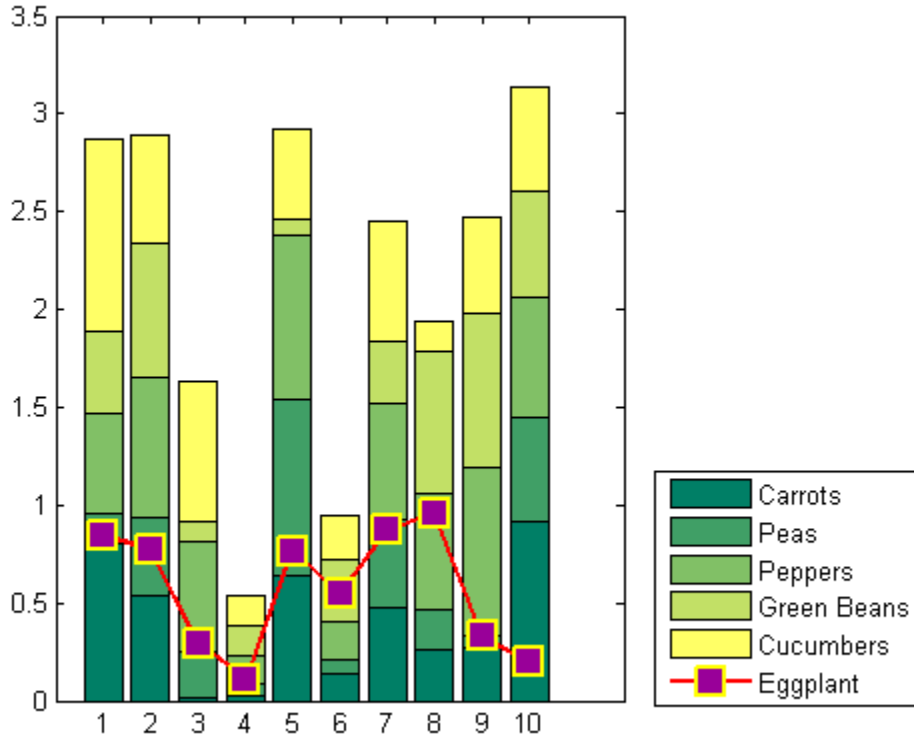

## Alternatives

Add a legend to a selected axes on a graph with the **Insert Legend** tool



on the figure toolbar, or use **Insert > Legend** from the figure menu. Use the Property Editor to modify the position, font, and other properties of a legend.

## **Moving the Legend**

Move the legend by pressing the left mouse button while the cursor is over the legend and dragging the legend to a new location. Double-clicking a label allows you to edit the label.

## **See Also**

LineStyle | plot | Text Properties

## **How To**

- “Add Legend to Graph Using Plot Tools”

# legendre

---

**Purpose** Associated Legendre functions

**Syntax**  
P = legendre(n,X)  
S = legendre(n,X,'sch')  
N = legendre(n,X,'norm')

**Description** P = legendre(n,X) computes the associated Legendre functions of degree n and order m = 0,1,...,n, evaluated for each element of X. Argument n must be a scalar integer, and X must contain real values in the domain  $-1 \leq x \leq 1$ .

If X is a vector, then P is an (n+1)-by-q matrix, where q = length(X). Each element P(m+1,i) corresponds to the associated Legendre function of degree n and order m evaluated at X(i).

In general, the returned array P has one more dimension than X, and each element P(m+1,i,j,k,...) contains the associated Legendre function of degree n and order m evaluated at X(i,j,k,...). Note that the first row of P is the Legendre polynomial evaluated at X, i.e., the case where m = 0.

S = legendre(n,X,'sch') computes the “Schmidt Seminormalized Associated Legendre Functions” on page 1-3715.

N = legendre(n,X,'norm') computes the “Fully Normalized Associated Legendre Functions” on page 1-3715.

## Definitions Associated Legendre Functions

The Legendre functions are defined by

$$P_n^m(x) = (-1)^m (1-x^2)^{m/2} \frac{d^m}{dx^m} P_n(x),$$

where

$$P_n(x)$$

is the Legendre polynomial of degree n:

$$P_n(x) = \frac{1}{2^n n!} \left[ \frac{d^n}{dx^n} (x^2 - 1)^n \right]$$

## Schmidt Seminormalized Associated Legendre Functions

The Schmidt seminormalized associated Legendre functions are related to the nonnormalized associated Legendre functions  $P_n^m(x)$  by

$$P_n(x) \text{ for } m = 0,$$

$$S_n^m(x) = (-1)^m \sqrt{\frac{2(n-m)!}{(n+m)!}} P_n^m(x) \text{ for } m > 0.$$

## Fully Normalized Associated Legendre Functions

The fully normalized associated Legendre functions are normalized such that

$$\int_{-1}^1 (N_n^m(x))^2 dx = 1$$

and are related to the unnormalized associated Legendre functions  $P_n^m(x)$  by

$$N_n^m = (-1)^m \sqrt{\frac{(n + \frac{1}{2})(n - m)!}{(n + m)!}} P_n^m(x)$$

## Examples

### Example 1

The statement `legendre(2,0:0.1:0.2)` returns the matrix

# legendre

---

	<b>x = 0</b>	<b>x = 0.1</b>	<b>x = 0.2</b>
m = 0	-0.5000	-0.4850	-0.4400
m = 1	0	-0.2985	-0.5879
m = 2	3.0000	2.9700	2.8800

## Example 2

Given,

```
X = rand(2,4,5);
n = 2;
P = legendre(n,X)
```

then

```
size(P)
ans =
 3 2 4 5
```

and

```
P(:,1,2,3)
ans =
 -0.2475
 -1.1225
 2.4950
```

is the same as

```
legendre(n,X(1,2,3))
ans =
 -0.2475
 -1.1225
 2.49501
```

## Algorithms

legendre uses a three-term backward recursion relationship in  $m$ . This recursion is on a version of the Schmidt seminormalized

associated Legendre functions  $P_n^m(x) = (-1)^m (1-x^2)^{m/2} \frac{d^m}{dx^m} P_n(x)$ , which are complex spherical harmonics. These functions are related to the standard Abramowitz and Stegun [1] functions

$$P_n^m(x) = (-1)^m (1-x^2)^{m/2} \frac{d^m}{dx^m} P_n(x), \text{ by}$$

$$P_n^m(x) = (-1)^m (1-x^2)^{m/2} \frac{d^m}{dx^m} P_n(x),$$

They are related to the Schmidt form given previously by

$$P_n^m(x) = (-1)^m (1-x^2)^{m/2} \frac{d^m}{dx^m} P_n(x),$$

## References

- [1] Abramowitz, M. and I. A. Stegun, *Handbook of Mathematical Functions*, Dover Publications, 1965, Ch.8.
- [2] Jacobs, J. A., *Geomagnetism*, Academic Press, 1987, Ch.4.

# length

---

**Purpose** Length of vector or largest array dimension

**Syntax** `numberOfElements = length(array)`

**Description** `numberOfElements = length(array)` finds the number of elements along the largest dimension of an array. `array` is an array of any MATLAB data type and any valid dimensions. `numberOfElements` is a whole number of the MATLAB double class.

For nonempty arrays, `numberOfElements` is equivalent to `max(size(array))`. For empty arrays, `numberOfElements` is zero.

**Examples** Create a 1-by-8 array `X` and use `length` to find the number of elements in the second (largest) dimension:

```
X = [5, 3.4, 72, 28/4, 3.61, 17 94 89];
```

```
length(X)
ans =
 8
```

---

Create a 4-dimensional array `Y` in which the third dimension is the largest. Use `length` to find the number of elements in that dimension:

```
Y = rand(2, 5, 17, 13);
```

```
length(Y)
ans =
 17
```

---

Create a struct array `S` with character and numeric fields of different lengths. Use the `structfun` function to apply `length` to each field of `S`:

```
S = struct('f1', 'Name:', 'f2', 'Charlie', ...
 'f3', 'DOB:', 'f4', 1917)
```



```
S =
 f1: 'Name:'
 f2: 'Charlie'
 f3: 'DOB:'
 f4: 1917

structfun(@(field)length(field), S)
ans =
 5
 7
 4
 1
```

## See Also

[numel](#)  |  [size](#)  |  [ndims](#)

# containers.Map.length

---

**Purpose** Length of containers.Map object

**Syntax** `mapLength = length(mapObj)`

**Description** `mapLength = length(mapObj)` returns the number of key-value pairs in `mapObj`.

**Input Arguments** **mapObj**  
Object of class `containers.Map`.

**Output Arguments** **mapLength**  
Scalar numeric value that indicates the number of key-value pairs in `mapObj`. This number is equivalent to `size(mapObj,1)` and to `mapObj.Count`.

## Examples **Determine the Length of a Map**

Create a map, and determine the number of key-value pairs:

```
myKeys = {'a','b','c'};
myValues = [1,2,3];
mapObj = containers.Map(myKeys,myValues);
```

```
mapLength = length(mapObj)
```

This code returns

```
mapLength =
3
```

**See Also** `containers.Map` | `isKey` | `keys` | `size` | `values`

**Purpose** Length of serial port object array

**Syntax** length(obj)

**Description** length(obj) returns the length of the serial port object, obj. It is equivalent to the command max(size(obj)).

**See Also** size

# length (tscollection)

---

**Purpose** Length of time vector

**Syntax** `length(tsc)`

**Description** `length(tsc)` returns an integer that represents the length of the time vector for the `tscollection` object `tsc`.

**See Also** `tscollection` | `isempty (tscollection)` | `size (tscollection)`

**Purpose** Return information on functions in shared library

**Syntax**

```
libfunctions libname

m = libfunctions(libname)
___ = libfunctions(___ , '-full')
```

**Description** libfunctions libname displays names of functions defined in library, libname. If you called loadlibrary using the alias option, then you must use the alias name for the libname argument.

m = libfunctions(libname) returns names of functions in cell array m.

\_\_\_ = libfunctions(\_\_\_ , '-full') returns function signatures.

## Input Arguments

### libname - Name of shared library

string

Name of shared library, specified as a string. If you call loadlibrary using the alias option, then you must use the alias name for the libname argument.

### Data Types

char

## Output Arguments

### m - Function names

cell array

Functions names, returned as a cell array.

## Examples

### Display Function Signatures

Load the example library, shrlibsamle, and list the functions.

```
if not(libisloaded('shrlibsamle'))
 addpath(fullfile(matlabroot,'extern','examples','shrlib'))
 loadlibrary('shrlibsamle')
```

# libfunctions

---

```
end
m = libfunctions('shrlibsample', '-full')

m =

 '[double, doublePtr] addDoubleRef(double, doublePtr, double)'
 'double addMixedTypes(int16, int32, double)'
 '[double, c_structPtr] addStructByRef(c_structPtr)'
 'double addStructFields(c_struct)'
 'c_structPtrPtr allocateStruct(c_structPtrPtr)'
 'voidPtr deallocateStruct(voidPtr)'
 'lib.pointer exportedDoubleValue'
 'lib.pointer getListOfStrings'
 'doublePtr multDoubleArray(doublePtr, int32)'
 '[lib.pointer, doublePtr] multDoubleRef(doublePtr)'
 'int16Ptr multiplyShort(int16Ptr, int32)'
 'doublePtr print2darray(doublePtr, int32)'
 'printExportedDoubleValue'
 'cstring readEnum(Enum1)'
 '[cstring, cstring] stringToUpper(cstring)'
```

## Limitations

- Use with libraries that are loaded using the `loadlibrary` function.

## See Also

`loadlibrary` | `libfunctionsview` | `calllib`

**Purpose** Display shared library function signatures in window

**Syntax** `libfunctionsview libname`

**Description** `libfunctionsview libname` displays information about functions in library, `libname`, in a new window.

**Input Arguments** **libname - Name of shared library**  
*string*

Name of shared library, specified as a string. If you call `loadlibrary` using the `alias` option, then you must use the alias name for the `libname` argument.

**Data Types**  
`char`

**Limitations**

- Use with libraries that are loaded using the `loadlibrary` function.

**Examples** **Display Function Signatures for Library `libmx`**

```
if not(libisloaded('libmx'))
 hfile = fullfile(matlabroot,'extern','include','matrix.h');
 loadlibrary('libmx',hfile)
end
libfunctionsview libmx
```

MATLAB creates a new window displaying function signatures.

**See Also** `libfunctions` | `calllib`

# libisloaded

---

**Purpose** Determine if shared library is loaded

**Syntax** `tf = libisloaded(libname)`

**Description** `tf = libisloaded(libname)` returns logical 1 (true) if the shared library, `libname`, is loaded. Otherwise, it returns logical 0 (false).

**Input Arguments** **libname - Name of shared library**  
*string*

Name of shared library, specified as a string. If you call `loadlibrary` using the `alias` option, then you must use the alias name for the `libname` argument.

**Data Types**  
*char*

**Examples** **Load Functions in Library**

Load example library, `shrlibsample`, if it is not already loaded.

```
if ~libisloaded('shrlibsample')
 loadlibrary('shrlibsample')
end
```

**See Also** `loadlibrary` | `unloadlibrary`



<b>Purpose</b>	Pointer object for use with shared library
<b>Syntax</b>	<pre>p = libpointer p = libpointer(DataType) p = libpointer(DataType,Value)</pre>
<b>Description</b>	<p>p = libpointer creates NULL pointer p of type voidPtr.</p> <p>p = libpointer(DataType) creates NULL pointer of specified DataType.</p> <p>p = libpointer(DataType,Value) creates pointer initialized to a copy of Value.</p>
<b>Limitations</b>	<ul style="list-style-type: none"><li>• Use with libraries that are loaded using the loadlibrary function.</li></ul>
<b>Input Arguments</b>	<p><b>DataType - Type of pointer</b> string</p> <p>Type of pointer, specified as a string, of any MATLAB numeric type, structure defined in the library, or enumeration defined in the library. For a list of valid MATLAB numeric types, refer to these tables in “C and MATLAB Equivalent Types”.</p> <ul style="list-style-type: none"><li>• MATLAB Primitive Types</li><li>• MATLAB Extended Types</li></ul> <p><b>Example:</b> 'int16Ptr'</p> <p><b>Data Types</b> char</p> <p><b>Value - Value for pointer object</b> any valid value</p> <p>Value, specified as any valid value for given type.</p>

# libpointer

---

## Tips

- This is an advanced feature for experienced C programmers. MATLAB automatically converts data passed to and from external library functions to the data type expected by the external function. Use a `lib.pointer` object instead of automatic conversion in the following situations.
  - You want to modify the data in the input arguments.
  - You are passing large amounts of data, and you want to control when MATLAB makes copies of the data.
  - The library stores and uses the pointer for a period of time so you want the MATLAB function to control the lifetime of the `lib.pointer` object.

## See Also

`lib.pointer` | `calllib` | `libstruct`

## Related Examples

- “Multilevel Pointers”

## Concepts

- “Working with Pointer Arguments”

<b>Purpose</b>	Pointer object compatible with C pointer				
<b>Description</b>	<p>MATLAB automatically converts arguments that are passed by reference to a function in an external library. Use a pointer object instead of automatic conversion in the following situations.</p> <ul style="list-style-type: none"><li>• The function modifies data in an input argument.</li><li>• You are passing large amounts of data, and you want to control when MATLAB makes copies of the data.</li><li>• The library stores and uses the pointer for a period of time so you want the MATLAB function to control the lifetime of the lib.pointer object.</li></ul>				
<b>Construction</b>	<p>To create a lib.pointer object, use the MATLAB libpointer function.</p> <p>A library function can return a lib.pointer object. Use the setdatatype method to manually convert the argument to use in MATLAB.</p>				
<b>Properties</b>	<p><b>DataType</b></p> <p>Type of pointer, specified as a string, of any MATLAB numeric type, structure defined in the library, or enumeration defined in the library. For a list of valid MATLAB numeric types, refer to these tables in “C and MATLAB Equivalent Types”.</p> <ul style="list-style-type: none"><li>• MATLAB Primitive Types</li><li>• MATLAB Extended Types</li></ul> <p><b>Value</b></p> <p>Value, specified as any valid value for given type.</p>				
<b>Methods</b>	<table><tr><td>disp</td><td>Display lib.pointer type</td></tr><tr><td>isNull</td><td>Points to NULL pointer</td></tr></table>	disp	Display lib.pointer type	isNull	Points to NULL pointer
disp	Display lib.pointer type				
isNull	Points to NULL pointer				

# lib.pointer

---

plus	+ (plus) operator for pointer arithmetic
reshape	Reshape lib.pointer array
setdatatype	Initialize type and size of lib.pointer object

## Definitions

A passed-by-reference argument in the function signature has type names ending with Ptr or PtrPtr.

## Examples

### Create Pointer

Create a pointer, pv, of type int16, initialized to 485.

```
pv = libpointer('int16Ptr',485);
```

Display the properties of pv.

```
get(pv)
```

```
Value: 485
DataType: 'int16Ptr'
```

## See Also

libpointer

## Concepts

- “Working with Pointer Arguments”

<b>Purpose</b>	Display lib.pointer type
<b>Syntax</b>	disp(h)
<b>Description</b>	disp(h) displays type for lib.pointer object, h.
<b>Input Arguments</b>	<b>h - lib.pointer object.</b> handle lib.pointer object, specified as a handle.
<b>Examples</b>	<b>Display lib.pointer Type</b> Create a double pointer set to 15. <pre>xp = libpointer('doublePtr',15);</pre> Display pointer data type. <pre>disp(xp)</pre> <pre>libpointer</pre>

# lib.pointer.isNull

---

<b>Purpose</b>	Points to NULL pointer
<b>Syntax</b>	<code>tf = isNull(h)</code>
<b>Description</b>	<code>tf = isNull(h)</code> returns true if <code>h</code> is a <code>lib.pointer</code> object.
<b>Input Arguments</b>	<b><code>h</code> - lib.pointer object.</b> <code>handle</code> lib.pointer object, specified as a handle.
<b>Examples</b>	<b>Create Null lib.pointer Object</b> <pre>nullp = libpointer('doublePtr', []); isNull(nullp)</pre>

<b>Purpose</b>	+ (plus) operator for pointer arithmetic
<b>Syntax</b>	<pre>hout = plus(h,offset) hout = h + offset</pre>
<b>Description</b>	<p><code>hout = plus(h,offset)</code> returns pointer <code>hout</code>. Pointer <code>hout</code> is valid only as long as the original pointer, <code>h</code>, exists.</p> <p><code>hout = h + offset</code> is an alternative syntax.</p>
<b>Input Arguments</b>	<p><b>h - lib.pointer object.</b> <code>handle</code> lib.pointer object, specified as a handle.</p> <p><b>offset - Scalar increment</b> <code>uint64</code> Scalar increment, specified as <code>uint64</code>, from <code>h</code>.</p>
<b>Related Examples</b>	<ul style="list-style-type: none"><li>• “Iterate Through an Array”</li></ul>

# lib.pointer.reshape

---

<b>Purpose</b>	Reshape lib.pointer array
<b>Syntax</b>	reshape(h,xdim,ydim)
<b>Description</b>	reshape(h,xdim,ydim) creates an xdim-by-ydim matrix from lib.pointer object h.
<b>Input Arguments</b>	<p><b>h - lib.pointer object.</b> handle lib.pointer object, specified as a handle.</p> <p><b>xdim - Size of x dimension</b> double Size of x dimension, specified as double.</p> <p><b>ydim - Size of y dimension</b> double Size of y dimension, specified as double.</p>



<b>Purpose</b>	Initialize type and size of lib.pointer object
<b>Syntax</b>	setdatatype(h,type,size)
<b>Description</b>	setdatatype(h,type,size) sets data type, type, of size, to lib.pointer, h.
<b>Input Arguments</b>	<p><b>h - lib.pointer object.</b> handle lib.pointer object, specified as a handle.</p> <p><b>type - Data type</b> string Data type, specified as a string.</p> <p><b>size - Size</b> double Size, specified as double.</p>

## Examples **Set Size and Type of lib.pointer Output Variable**

Load the shrlibsample library.

```
if ~libisloaded('shrlibsample')
 addpath(fullfile(matlabroot,'extern','examples','shrlib'))
 loadlibrary('shrlibsample')
end
```

The multDoubleRef function takes a scalar value specified as doubleptr. Create variable xp as a lib.pointer object, and call the function.

```
xp = libpointer('doublePtr',99);
[xobj,xval] = calllib('shrlibsample','multDoubleRef',xp);
```

To use the variable xobj, set its size and data type.

# lib.pointer.setdatatype

---

```
setdatatype(xobj, 'doublePtr', 1, 1)
xobj.Value
```

```
ans =
```

```
495
```

**Purpose** Convert MATLAB structure to C-style structure for use with shared library

**Syntax**  
S = libstruct(structtype)  
S = libstruct(structtype,mlstruct)

**Description**  
S = libstruct(structtype) creates NULL pointer to MATLAB libstruct object S.  
  
S = libstruct(structtype,mlstruct) creates pointer initialized to mlstruct.

**Limitations**

- Use with libraries that are loaded using the loadlibrary function.
- You can only use the libstruct function on scalar structures.
- When converting a MATLAB structure to a libstruct object, the structure must adhere to the requirements listed in “Structure Argument Requirements”.

**Input Arguments**

**structtype - C structure**  
structure  
C structure defined in shared library.

**mlstruct - MATLAB structure**  
structure  
MATLAB structure used to initialize the fields in S.

**Data Types**  
struct

**Output Arguments**

**S - Pointer**  
MATLAB libstruct object  
Pointer, returned as MATLAB libstruct object.

## Examples

### Call Function with `c_struct` Input Argument

Call the `addStructFields` function by creating a variable of type `c_struct`.

Load the `shrlibsample` library, which contains the `c_struct` type.

```
if ~libisloaded('shrlibsample')
 addpath(fullfile(matlabroot,'extern','examples','shrlib'))
 loadlibrary('shrlibsample')
end
```

Display function signatures for `shrlibsample` and search the list for the `addStructFields` entry.

```
libfunctionsview shrlibsample

double addStructFields(c_struct)
```

The input argument is a pointer to a `c_struct` data type.

Create a MATLAB structure, `sm`.

```
sm.p1 = 476; sm.p2 = -299; sm.p3 = 1000;
```

Construct a `libstruct` object `sc` from the `c_struct` type.

```
sc = libstruct('c_struct',sm)
```

The fields of `sc` contain the values of the MATLAB structure, `sm`.

Call the `addStructFields` function.

```
calllib('shrlibsample','addStructFields',sc)
```

```
ans =
 1177
```

To clean up, first clear the `libstruct` object, and then unload the library.

```
clear sc
unloadlibrary shrlibsample
```

## Tips

- If a function in the shared library has a structure argument, use `libstruct` to create the argument. The `libstruct` function creates a C-style structure that you pass to functions in the library. You handle this structure in MATLAB as you would a true MATLAB structure.

## See Also

`loadlibrary` | `libfunctionsview`

## Concepts

- “Working with Structure Arguments”

# license

---

**Purpose** Return license number or perform licensing task

**Syntax**

```
license
license('inuse')
S = license('inuse')
S = license('inuse', feature)
license('test', feature)
license('test', feature, toggle)
[TF errmsg] = license('checkout', feature)
```

**Description** `license` returns the license number for this MATLAB product. The return value is always a string but is not guaranteed to be a number. The following table lists text strings that `license` can return.

String	Description
'demo'	MATLAB is a demonstration version
'student'	MATLAB is the student version
'unknown'	License number cannot be determined

`license('inuse')` returns a list of licenses checked out in the current MATLAB session. In the list, products are listed alphabetically by their license feature names, i.e., the text string used to identify products in the INCREMENT lines in a License File (`license.dat`). Note that the feature names returned in the list contain only lower-case characters.

`S = license('inuse')` returns an array of structures, where each structure represents a checked-out license. The structures contains two fields: `feature` and `user`. The `feature` field contains the license feature name. The `user` field contains the username of the person who has the license checked out.

`S = license('inuse', feature)` checks if the product specified by the text string `feature` is checked out in the current MATLAB session. If the product is checked out, the `license` function returns the product name and the username of the person who has it checked out in the

structure `S`. If the product is not currently checked out, the fields in the structure are empty.

The `feature` string must be a license feature name, spelled exactly as it appears in the `INCREMENT` lines in a License File. For example, the string `'Identification_Toolbox'` is the feature name for the System Identification Toolbox™. The `feature` string is not case-sensitive and must not exceed 27 characters.

`license('test', feature)` tests if a license exists for the product specified by the text string `feature`. The `license` command returns 1 if the license exists and 0 if the license does not exist. The `feature` string identifies a product, as described in the previous syntax.

---

**Note** Testing for a license only confirms that the license exists. It does not confirm that the license can be checked out. For example, `license` will return 1 if a license exists, even if the license has expired or if a system administrator has excluded you from using the product in an options file. The existence of a license does not indicate that the product is installed.

---

`license('test', feature, toggle)` enables or disables testing of the product specified by the text string `feature`, depending on the value of `toggle`. The parameter `toggle` can have either of two values:

'enable' The syntax `license('test', feature)` returns 1 if the product license exists and 0 if the product license does not exist.

'disable' The syntax `license('test', feature)` always returns 0 (product license does not exist) for the specified product.

# license

---

---

**Note** Disabling a test for a particular product can impact other tests for the existence of the license, not just tests performed using the `license` command.

---

`[TF errmsg] = license('checkout',feature)` checks out a license for the product specified by the text string `feature`, returning 1 if it could check out a license or 0 if it could not check out a license. If you specify the optional second output argument, `errmsg`, the `license` function returns the text of any error message encountered, or an empty string if the checkout succeeded.

## Examples

Get the license number for this MATLAB.

```
license
```

Get a list of licenses currently being used. Note that the products appear in alphabetical order by their license feature name in the list returned.

```
license('inuse')
```

```
image_toolbox
map_toolbox
matlab
```

Get a list of licenses in use with information about who is using the license.

```
S = license('inuse');
```

```
S(1)
```

```
ans =
```

```
 feature: 'image_toolbox'
 user: 'juser'
```



Determine if the license for MATLAB is currently in use.

```
S = license('inuse','MATLAB')
```

```
S =
```

```
 feature: 'matlab'
 user: 'jsmith'
```

Determine if a license exists for the Mapping Toolbox™.

```
license('test','map_toolbox')
```

```
ans =
```

```
 1
```

Check out a license for the Control System Toolbox™.

```
license('checkout','control_toolbox')
```

```
ans =
```

```
 1
```

Determine if the license for the Control System Toolbox is checked out.

```
license('inuse')
```

```
control_toolbox
image_toolbox
map_toolbox
matlab
```

## See Also

```
isstudent
```

# light

---

<b>Purpose</b>	Create light object
<b>Syntax</b>	<pre>light('PropertyName',propertyvalue,...) handle = light(...)</pre>
<b>Properties</b>	For a list of properties, see Light Properties.
<b>Description</b>	<p><code>light</code> creates a light object in the current axes. Lights affect only patch and surface objects.</p> <p><code>light('PropertyName',propertyvalue,...)</code> creates a light object using the specified values for the named properties. For a description of the properties, see Light Properties. The MATLAB software parents the light to the current axes unless you specify another axes with the Parent property.</p> <p><code>handle = light(...)</code> returns the handle of the light object created.</p>
<b>Tips</b>	<p>You cannot see a light object <i>per se</i>, but you can see the effects of the light source on patch and surface objects. You can also specify an axes-wide ambient light color that illuminates these objects. However, ambient light is visible only when at least one light object is present and visible in the axes.</p> <p>You can specify properties as property name/property value pairs, structure arrays, and cell arrays (see <code>set</code> and <code>get</code> for examples of how to specify these data types).</p> <p>See also the patch and surface AmbientStrength, DiffuseStrength, SpecularStrength, SpecularExponent, SpecularColorReflectance, and VertexNormals properties. Also see the lighting and material commands.</p>
<b>Examples</b>	<p>Light the peaks surface plot with a light source located at infinity and oriented along the direction defined by the vector [1 0 0], that is, along the <i>x</i>-axis.</p> <pre>h = surf(peaks);</pre>

```
set(h,'FaceLighting','phong','FaceColor','interp',...
 'AmbientStrength',0.5)
light('Position',[1 0 0],'Style','infinite');
```

## Setting Default Properties

You can set default light properties on the axes, figure, and root object levels:

```
set(0,'DefaultLightProperty',PropertyValue...)
set(gcf,'DefaultLightProperty',PropertyValue...)
set(gca,'DefaultLightProperty',PropertyValue...)
```

where *Property* is the name of the light property and *PropertyValue* is the value you are specifying. Use `set` and `get` to access light properties.

## Tutorials

For more information about lighting, see “Lighting Overview”.

## See Also

[lighting](#) | [material](#) | [patch](#) | [surface](#) | [Light Properties](#)

# Light Properties

---

## Purpose

Light properties

## Creating Light Objects

Use `light` to create light objects.

## Modifying Properties

You can set and query graphics object properties in two ways:

- “Customize Objects in Graph” is an interactive tool that enables you to see and change object property values.
- The `set` and `get` commands enable you to set and query the values of properties.

To change the default values of properties, see “Setting Default Property Values”.

See “Core Graphics Objects” for general information about this type of object.

## Light Property Descriptions

This section provides a description of properties. Curly braces { } enclose default values.

`BeingDeleted`  
`on` | `{off}` (read-only)

*This object is being deleted.* Mechanism to determine if objects are in the process of being deleted. MATLAB sets the `BeingDeleted` property to `on` when the object’s delete function callback is called (see the `DeleteFcn` property). It remains set to `on` while the delete function executes, after which the object no longer exists.

For example, an object’s delete function calls other functions that act on a number of different objects. If a function does not need to perform an action on an about-be-deleted object, it can check the object’s `BeingDeleted` property before acting.

`BusyAction`  
`cancel` | `{queue}`

## *Callback queuing*

Determines how MATLAB handles the execution of interrupting callbacks.

A *running* callback is the currently executing callback. The *interrupting* callback is the callback that tries to interrupt the *running* callback. The `BusyAction` property of the *interrupting* callback determines how MATLAB handles its execution. When the `BusyAction` property is set to:

- 'queue' — Puts the *interrupting* callback in a queue to be processed after the *running* callback finishes execution.
- 'cancel' — Discards the *interrupting* callback as MATLAB finishes execution.

For information about how the `Interruptible` property of the callback controls whether other callbacks can interrupt the *running* callback, see the `Interruptible` property description.

`ButtonDownFcn`  
function handle

This property is not used on lights.

`Children`  
handles

The empty matrix; light objects have no children.

`Clipping`  
on | off

*Clipping mode.* This property has no effect on light objects.

`Color`  
`ColorSpec`

# Light Properties

---

*Light color.* Defines the color of the light emanating from the light object. Use a three-element RGB vector or one of the MATLAB predefined names. Default value is [1 1 1] (white). See the `ColorSpec` reference page for more information on specifying color.

## CreateFcn

function handle | cell array containing function handle and additional arguments | string (not recommended)

*Callback function executed during object creation.* Executes when MATLAB creates a light object. You must define this property as a default value for lights or in a call to the `light` function to create a new light object. For example, the following statement:

```
set(0,'DefaultLightCreateFcn',@light_create)
```

defines a default value for the line `CreateFcn` property on the root level that sets the current figure colormap to `gray` and uses a reddish light color whenever you create a light object.

```
function light_create(src,evnt)
% src - the object that is the source of the event
% evnt - empty for this property
 set(src,'Color',[.9 .2 .2])
 set(gcf,'Colormap',gray)
end
```

MATLAB executes this function after setting all light properties. Setting this property on an existing light object has no effect. The function must define at least two input arguments (handle of light object created and an event structure, which is empty for this property).

The handle of the object whose `CreateFcn` is being executed is passed by MATLAB as the first argument to the callback function and is also accessible through the root `CallbackObject` property, which you can query using `gcbo`.

For information on the syntax of callback functions, see [Function Handle Callbacks](#).

## DeleteFcn

function handle | cell array containing function handle and additional arguments | string (not recommended)

*Delete light callback function.* Executes when you delete the light object (for example, when you issue a `delete` command or clear the axes `cla` or figure `clf`).

For example, the following function displays object property data before the object is deleted.

```
function delete_fcn(src,evnt)
% src - the object that is the source of the event
% evnt - empty for this property
 obj_tp = get(src,'Type');
 disp([obj_tp, ' object deleted'])
 disp('Its user data is:')
 disp(get(src,'UserData'))
end
```

MATLAB executes the function before deleting the object's properties so these values are available to the callback function. The function must define at least two input arguments (handle of object being deleted and an event structure, which is empty for this property).

The handle of the object whose `DeleteFcn` is being executed is passed by MATLAB as the first argument to the callback function and is also accessible through the root `CallbackObject` property, which you can query using `gcbo`.

For information on the syntax of callback functions, see [Function Handle Callbacks](#).

HandleVisibility  
{on} | callback | off

*Control access to object's handle.* Determines when an object's handle is visible in its parent's list of children. `HandleVisibility` is useful for preventing command-line users from accidentally drawing into or deleting a figure that contains only user interface devices (such as a dialog box).

- `on` — Handles are always visible.
- `callback` — Handles are visible from within callback routines or functions invoked by callback routines, but not from within functions invoked from the command line. This provides a means to protect GUIs from command-line users, while allowing callback routines to have access to object handles.
- `off` — Handles are invisible at all times. Use this option when a callback invokes a function that could damage the GUI (such as evaluating a user-typed string). This option temporarily hides its own handles during the execution of that function.

When a handle is not visible in its parent's list of children, it cannot be returned by functions that obtain handles by searching the object hierarchy or querying handle properties. This includes `get`, `findobj`, `gca`, `gcf`, `gco`, `newplot`, `cla`, `clf`, and `close`.

When a handle's visibility is restricted using `callback` or `off`, the object's handle does not appear in its parent's `Children` property, figures do not appear in the root's `CurrentFigure` property, objects do not appear in the root's `CallbackObject` property or in the figure's `CurrentObject` property, and axes do not appear in their parent's `CurrentAxes` property.

You can set the root `ShowHiddenHandles` property to `on` to make all handles visible regardless of their `HandleVisibility` settings (this does not affect the values of the `HandleVisibility` properties).



Handles that are hidden are still valid. If you know an object's handle, you can `set` and `get` its properties, and pass it to any function that operates on handles.

`HitTest`  
`{on} | off`

This property is not used by light objects.

`Interruptible`  
`off | {on}`

*Callback routine interruption*

Controls whether MATLAB can interrupt an object's callback function when subsequent callbacks attempt to interrupt it.

For Graphics objects, the `Interruptible` property affects only the callbacks for the `ButtonDownFcn` property. A *running* callback is the currently executing callback. The *interrupting* callback is the callback that tries to interrupt the *running* callback. MATLAB handles both the callbacks based on the `Interruptible` property of the object of the *running* callback.

When the `Interruptible` property is set to:

- 'off', MATLAB finishes execution of the *running* callback without any interruptions
- 'on', these conditions apply:
  - If there is a `drawnow`, `figure`, `getframe`, `waitfor`, or `pause` command in the *running* callback, then MATLAB executes the *interrupting* callbacks which are already in the queue and returns to finish execution of the current callback.
  - If one of the above functions is not in the *running* callback, then MATLAB finishes execution of the current callback without any interruption.

# Light Properties

---

BusyAction property of the object of interrupting callback determines whether the callback should be ignored or should be put in the queue.

Setting Interruptible property to on (default), allows a callback from other graphics objects to interrupt callback functions originating from this object.

---

**Note** MATLAB does not save the state of properties or the display when an interruption occurs. For example, the handle returned by the gca or(gcf) command may be changed as another callback is executed.

---

After the function that interrupts a callback completes, the callback resumes execution where it halted when interrupted. For more information, see “Control Callback Execution and Interruption”.

## Parent

handle of parent axes

*Parent of light object.* This property contains the handle of the light object’s parent. The parent of a light object is the axes object that contains it.

Note that light objects cannot be parented to hggroup or hgtransform objects.

## Position

[x,y,z] in axes data units

*Location of light object.* Vector defining the location of the light object. The vector is defined from the origin to the specified x-, y-, and z-coordinates. The placement of the light depends on the setting of the Style property:

- If the `Style` property is `local`, `Position` specifies the actual location of the light (which is then a point source that radiates from the location in all directions).
- If the `Style` property is `infinite`, `Position` specifies the direction from which the light shines in parallel rays.

## Selected

on | off

This property is not used by light objects.

## SelectionHighlight

{on} | off

This property is not used by light objects.

## Style

{infinite} | local

*Parallel or divergent light source.*

- `infinite` — MATLAB places the light object at infinity (light rays are parallel).
- `local` — MATLAB places the light object at the location specified by the `Position` property (light rays diverge in all directions).

## Tag

string

*User-specified object label.* Provides a means to identify graphics objects with a user-specified label. The default is an empty string.

Use the `Tag` property and the `findobj` function to manipulate specific objects within a plotting hierarchy.

## Type

string (read-only)

# Light Properties

---

*Type of graphics object.* String that identifies the class of the graphics object. Use this property to find all objects of a given type within a plotting hierarchy. For light objects, Type is always 'light'.

UIContextMenu  
handle of uicontextmenu object

This property is not used by light objects.

UserData  
matrix

*User-specified data.* Data you want to associate with the light object. The default value is an empty array. MATLAB does not use this data, but you can access it using the `set` and `get` commands.

Visible  
{on} | off

*Light visibility.* While light objects themselves are not visible, you can see the light on patch and surface objects. When you set Visible to off, the light emanating from the source is not visible. There must be at least one light object in the axes whose Visible property is on for any lighting features to be enabled (including the axes AmbientLightColor and patch and surface AmbientStrength).

## See Also

light

<b>Purpose</b>	Create or position light object in spherical coordinates
<b>Syntax</b>	<pre>lightangle(az,e1) light_handle = lightangle(az,e1) lightangle(light_handle,az,e1) [az,e1] = lightangle(light_handle)</pre>
<b>Description</b>	<p><code>lightangle(az,e1)</code> creates a light at the position specified by azimuth and elevation. <code>az</code> is the azimuthal (horizontal) rotation and <code>e1</code> is the vertical elevation (both in degrees). The interpretation of azimuth and elevation is the same as that of the <code>view</code> command.</p> <p><code>light_handle = lightangle(az,e1)</code> creates a light and returns the handle of the light in <code>light_handle</code>.</p> <p><code>lightangle(light_handle,az,e1)</code> sets the position of the light specified by <code>light_handle</code>.</p> <p><code>[az,e1] = lightangle(light_handle)</code> returns the azimuth and elevation of the light specified by <code>light_handle</code>.</p>
<b>Tips</b>	By default, when a light is created, its style is <code>infinite</code> . If the light handle passed in to <code>lightangle</code> refers to a local light, the distance between the light and the camera target is preserved as the position is changed.
<b>Examples</b>	<pre>surf(peaks) axis vis3d h = light; for az = -50:10:50     lightangle(h,az,30) end drawnow end</pre>
<b>See Also</b>	<code>light</code>   <code>camlight</code>   <code>view</code>
<b>How To</b>	<ul style="list-style-type: none"><li>• “Lighting Overview”</li></ul>

# lighting

---

<b>Purpose</b>	Specify lighting algorithm
<b>Syntax</b>	<code>lighting flat</code> <code>lighting gouraud</code> <code>lighting phong</code> <code>lighting none</code>
<b>Description</b>	<p><code>lighting</code> selects the algorithm used to calculate the effects of light objects on all surface and patch objects in the current axes. In order for the <code>lighting</code> command to have any effects, however, you must create a lighting object by using the <code>light</code> function.</p> <p><code>lighting flat</code> produces uniform lighting across each of the faces of the object. Select this method to view faceted objects.</p> <p><code>lighting gouraud</code> calculates the vertex normals and interpolates linearly across the faces. Select this method to view curved surfaces.</p> <p><code>lighting phong</code> interpolates the vertex normals across each face and calculates the reflectance at each pixel. Select this choice to view curved surfaces. Phong lighting generally produces better results than Gouraud lighting, but it takes longer to render.</p> <p><code>lighting none</code> turns off lighting.</p>
<b>Tips</b>	The <code>surf</code> , <code>mesh</code> , <code>pcolor</code> , <code>fill</code> , <code>fill3</code> , <code>surface</code> , and <code>patch</code> functions create graphics objects that are affected by light sources. The <code>lighting</code> command sets the <code>FaceLighting</code> and <code>EdgeLighting</code> properties of surfaces and patches appropriately for the graphics object.
<b>See Also</b>	<code>fill</code>   <code>fill3</code>   <code>light</code>   <code>material</code>   <code>mesh</code>   <code>patch</code>   <code>pcolor</code>   <code>shading</code>   <code>surface</code>
<b>How To</b>	<ul style="list-style-type: none"><li>• “Lighting Overview”</li></ul>

**Purpose** Convert linear audio signal to mu-law

**Syntax** `mu = lin2mu(y)`

**Description** `mu = lin2mu(y)` converts linear audio signal amplitudes in the range  $-1 \leq Y \leq 1$  to mu-law encoded “flints” in the range  $0 \leq u \leq 255$ .

**See Also** `auwrite` | `mu2lin`

# line

---

**Purpose** Create line object

**Syntax**

```
line
line(X,Y)
line(X,Y,Z)
line(X,Y,Z,'PropertyName',propertyvalue,...)
line('XData',x,'YData',y,'ZData',z,...)
h = line(...)
```

**Properties** For a list of properties, see Line Properties.

**Description** `line` creates a line object in the current axes with default values `x = [0 1]` and `y = [0 1]`. You can specify the color, width, line style, and marker type, as well as other characteristics.

The `line` function has two forms:

- Automatic color and line style cycling. When you specify multiple line coordinate data as a column array using the informal syntax (i.e., the first three arguments are interpreted as the coordinates),

```
line(X,Y,Z)
```

MATLAB cycles through the axes `ColorOrder` and `LineStyleOrder` property values the way the `plot` function does. However, unlike `plot`, `line` does not call the `newplot` function.

- Purely low-level behavior. When you call `line` with only property name/property value pairs,

```
line('XData',x,'YData',y,'ZData',z)
```

MATLAB draws a line object in the current axes using the default line color (see the `colordef` function for information on color defaults). Note that you cannot specify matrix coordinate data with the low-level form of the `line` function.

`line(X,Y)` adds the line defined in vectors `X` and `Y` to the current axes. If `X` and `Y` are matrices of the same size, `line` draws one line per column.



`line(X,Y,Z)` creates lines in three-dimensional coordinates.

`line(X,Y,Z,'PropertyName',propertyvalue,...)` creates a line using the values for the property name/property value pairs specified and default values for all other properties. For a description of the properties, see [Line Properties](#).

See the `LineStyle` and `Marker` properties for a list of supported values.

`line('XData',x,'YData',y,'ZData',z,...)` creates a line in the current axes using the property values defined as arguments. This is the low-level form of the `line` function, which does not accept matrix coordinate data as the other informal forms described above.

`h = line(...)` returns a column vector of handles corresponding to each line object the function creates.

## Tips

In its informal form, the `line` function interprets the first three arguments (two for 2-D) as the X, Y, and Z coordinate data, allowing you to omit the property names. You must specify all other properties as name/value pairs. For example,

```
line(X,Y,Z,'Color','r','LineWidth',4)
```

The low-level form of the `line` function can have arguments that are only property name/property value pairs. For example,

```
line('XData',x,'YData',y,'ZData',z,...
 'Color','r','LineWidth',4)
```

Line properties control various aspects of the line object and are described in [Line Properties](#). You can also set and query property values after creating the line using `set` and `get`.

You can specify properties as property name/property value pairs, structure arrays, and cell arrays (see the `set` and `get` reference pages for examples of how to specify these data types).

Unlike high-level functions such as `plot`, `line` does not respect the settings of the figure and axes `NextPlot` properties. It simply adds line objects to the current axes. However, axes properties that are under

automatic control, such as the axis limits, can change to accommodate the line within the current axes.

## Connecting the dots

The coordinate data is interpreted as vectors of corresponding x, y, and z values:

```
X = [x(1) x(2) x(3)...x(n)]
Y = [y(1) y(2) y(3)...y(n)]
Z = [z(1) z(2) z(3)...z(n)]
```

where a point is determined by the corresponding vector elements:

```
p1(x(i),y(i),z(i))
```

For example, to draw a line from the point located at  $x = .3$  and  $y = .4$  and  $z = 1$  to the point located at  $x = .7$  and  $y = .9$  and  $z = 1$ , use the following data:

```
axis([0 1 0 1])
line([.3 .7],[.4 .9],[1 1],'Marker','.', 'LineStyle','-')
```

## Examples

This example uses the line function to add a shadow to plotted data. First, plot some data and save the line's handle:

```
t = 0:pi/20:2*pi;
hline1 = plot(t,sin(t),'k');
```

Next, add a shadow by offsetting the  $x$ -coordinates. Make the shadow line light gray and wider than the default LineWidth:

```
hline2 = line(t+.06,sin(t),...
 'LineWidth',4,'Color',[.8 .8 .8]);
```

Finally, pull the first line to the front:

```
set(gca,'Children',[hline1 hline2])
```

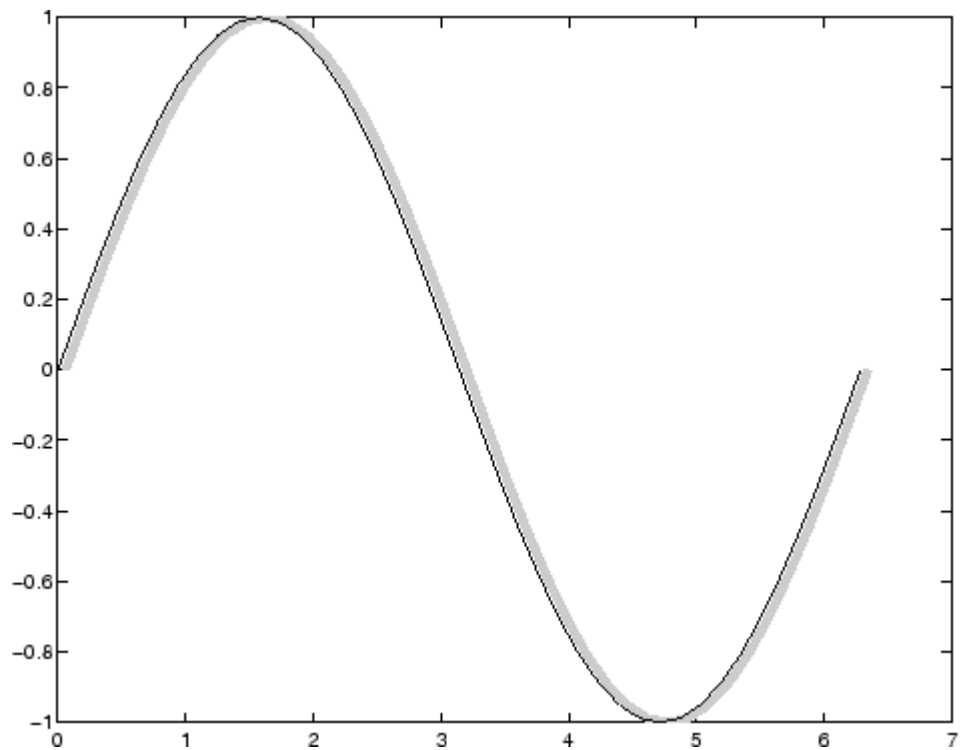

### Drawing Lines Interactively

You can use the `ginput` function to select points from a figure. For example:

```
[x,y] = ginput(5);
line(x,y)
```

### Drawing with mouse motion

You can use the axes `CurrentPoint` property and the figure `WindowButtonDownFcn` and `WindowButtonMotionFcn` properties to select a point with a mouse click and draw a line to another point by dragging the mouse, like a simple drawing program. The following

example illustrates a few useful techniques for doing this type of interactive drawing.

Click to view in editor — This example enables you to click and drag the cursor to draw lines.

Click to run example — Click the left mouse button in the axes and move the cursor, left-click to define the line end point, right-click to end drawing mode.

## Input Argument Dimensions — Informal Form

This statement reuses the one-column matrix specified for `ZData` to produce two lines, each having four points.

```
line(rand(4,2),rand(4,2),rand(4,1))
```

If all the data has the same number of columns and one row each, MATLAB transposes the matrices to produce data for plotting. For example,

```
line(rand(1,4),rand(1,4),rand(1,4))
```

is changed to

```
line(rand(4,1),rand(4,1),rand(4,1))
```

This also applies to the case when just one or two matrices have one row. For example, the statement

```
line(rand(2,4),rand(2,4),rand(1,4))
```

is equivalent to

```
line(rand(4,2),rand(4,2),rand(4,1))
```

You can set default line properties on the axes, figure, and root object levels:

```
set(0,'DefaultLinePropertyName',PropertyValue,...)
set(gcf,'DefaultLinePropertyName',PropertyValue,...)
```

## Setting Default Properties

```
set(gca, 'DefaultLinePropertyName', PropertyValue, ...)
```

Where *PropertyName* is the name of the line property and *PropertyValue* is the value you are specifying. Use `set` and `get` to access line properties.

**See Also**

[annotation](#) | [axes](#) | [newplot](#) | [plot](#) | [plot3](#) | [Line Properties](#)

# Line Properties

---

## Purpose

Line properties

## Creating Line Objects

Use `line` to create line objects.

## Modifying Properties

You can set and query graphics object properties in two ways:

- “Customize Objects in Graph” is an interactive tool that enables you to see and change object property values.
- The `set` and `get` commands enable you to set and query the values of properties.

To change the default values of properties, see “Setting Default Property Values”.

See *Core Graphics Objects* for general information about this type of object.

## Line Property Descriptions

Annotation

`hg.Annotation` object (read-only)

*Handle of Annotation object.* The `Annotation` property enables you to specify whether this line object is represented in a figure legend.

Querying the `Annotation` property returns the handle of an `hg.Annotation` object. The `hg.Annotation` object has a property called `LegendInformation`, which contains an `hg.LegendEntry` object.

Once you have obtained the `hg.LegendEntry` object, you can set its `IconDisplayStyle` property to control whether the line object is displayed in a figure legend:

IconDisplayStyle Value	Purpose
on	Represent this line object in a legend (default)
off	Do not include this line object in a legend
children	Same as on because line objects do not have children

## Setting the IconDisplayStyle property

Set the IconDisplayStyle of a graphics object with handle `hobj` to off:

```
hAnnotation = get(hobj, 'Annotation');
hLegendEntry = get(hAnnotation, 'LegendInformation');
set(hLegendEntry, 'IconDisplayStyle', 'off')
```

## Using the IconDisplayStyle property

See “Control Legend Content” for more information and examples.

## BeingDeleted

on | {off} (read-only)

*This object is being deleted.* Mechanism to determine if objects are in the process of being deleted. MATLAB sets the `BeingDeleted` property to `on` when the object’s delete function callback is called (see the `DeleteFcn` property). It remains set to `on` while the delete function executes, after which the object no longer exists.

For example, an object’s delete function calls other functions that act on a number of different objects. If a function does not need to perform an action on an about-be-deleted object, it can check the object’s `BeingDeleted` property before acting.

# Line Properties

---

## BusyAction

cancel | {queue}

### *Callback queuing*

Determines how MATLAB handles the execution of interrupting callbacks.

A *running* callback is the currently executing callback. The *interrupting* callback is the callback that tries to interrupt the *running* callback. The `BusyAction` property of the *interrupting* callback determines how MATLAB handles its execution. When the `BusyAction` property is set to:

- 'queue' — Puts the *interrupting* callback in a queue to be processed after the *running* callback finishes execution.
- 'cancel' — Discards the *interrupting* callback as MATLAB finishes execution.

For information about how the `Interruptible` property of the callback controls whether other callbacks can interrupt the *running* callback, see the `Interruptible` property description.

## ButtonDownFcn

function handle | cell array containing function handle and additional arguments | string (not recommended)

*Button press callback function.* Executes whenever you press a mouse button while the pointer is over the line object. The default is an empty array.

See the figure's `SelectionType` property to determine if modifier keys were also pressed.

Set this property to a function handle that references the callback. The function must define at least two input arguments (handle



of line associated with the button down event and an event structure, which is empty for this property).

The following example shows how to access the callback object's handle as well as the handle of the figure that contains the object from the callback function.

```
function button_down(src,evnt)
% src - the object that is the source of the event
% evnt - empty for this property
 sel_typ = get(gcf,'SelectionType')
 switch sel_typ
 case 'normal'
 disp('User clicked left-mouse button')
 set(src,'Selected','on')
 case 'extend'
 disp('User did a shift-click')
 set(src,'Selected','on')
 case 'alt'
 disp('User did a control-click')
 set(src,'Selected','on')
 set(src,'SelectionHighlight','off')
 end
end
```

Suppose `h` is the handle of a line object and the `button_down` function is on your MATLAB path. The following statement assigns the `button_down` function to the `ButtonDownFcn` property:

```
set(h,'ButtonDownFcn',@button_down)
```

For information on the syntax of callback functions, see [Function Handle Callbacks](#).

## Children

vector of handles

The empty matrix; line objects have no children.

# Line Properties

---

Clipping  
{on} | off

*Clipping mode.* MATLAB clips lines to the axes plot box by default. If you set `Clipping` to `off`, lines are displayed outside the axes plot box. This occurs if you create a line, set `hold` to `on`, freeze axis scaling (set `axis` to `manual`), and then create a longer line.

Color  
ColorSpec

*Line color.* A three-element RGB vector, or one of the MATLAB predefined names, specifying the line color. See the `ColorSpec` reference page for more information on specifying color.

CreateFcn  
function handle | cell array containing function handle and additional arguments | string (not recommended)

*Callback function executed during object creation.* Executes when MATLAB creates a line object. The default is an empty array.

You must specify the callback during the creation of the line or in a call to the `line` function to create a new line object.

For example, the statement:

```
set(0, 'DefaultLineCreateFcn', @line_create)
```

defines a default value for the line `CreateFcn` property on the root level that sets the axes `LineStyleOrder` whenever you create a line object. The following callback function must be on your MATLAB path when you execute the above statement.

```
function line_create(src, evnt)
% src - the object that is the source of the event
% evnt - empty for this property
axh = get(src, 'Parent');
set(axh, 'LineStyleOrder', '-.|-')
```

end

MATLAB executes this function after setting all line properties. Setting this property on an existing line object has no effect.

The function must define at least two input arguments (handle of line object created and an event structure, which is empty for this property).

The handle of the object whose `CreateFcn` is being executed is MATLAB as the first argument to the callback function and is also accessible only through the root `CallbackObject` property, which you can query using `gcbo`.

For information on the syntax of callback functions, see [Function Handle Callbacks](#).

## DeleteFcn

function handle | cell array containing function handle and additional arguments | string (not recommended)

*Delete line callback function.* Executes when you delete the line object. This happens when you call the `delete` command on the object, its parent axes, or the figure containing it. The default is an empty array.

For example, the following function displays object property data before the object is deleted.

```
function delete_fcn(src,evnt)
% src - the object that is the source of the event
% evnt - empty for this property
 obj_tp = get(src,'Type');
 disp([obj_tp, ' object deleted'])
 disp('Its user data is:')
 disp(get(src,'UserData'))
end
```

# Line Properties

---

MATLAB executes the function before deleting the object's properties so these values are available to the callback function. The function must define at least two input arguments (handle of line object being deleted and an event structure, which is empty for this property).

The handle of the object whose `DeleteFcn` is being executed is passed by MATLAB as the first argument to the callback function and is also accessible through the root `CallbackObject` property, which you can query using `gcbo`.

For information on the syntax of callback functions, see [Function Handle Callbacks](#).

`DisplayName`  
string

*String used by legend.* The `legend` function uses the `DisplayName` property to label the line object in the legend. The default is an empty string.

- If you specify string arguments with the `legend` function, MATLAB set `DisplayName` to the corresponding string and uses that string for the legend.
- If `DisplayName` is empty, `legend` creates a string of the form, `['data' n]`, where `n` is the number assigned to the object based on its location in the list of legend entries. However, `legend` does not set `DisplayName` to this string.
- If you edit the string directly in an existing legend, MATLAB set `DisplayName` to the edited string.
- If you specify a string for the `DisplayName` property and create the legend using the figure toolbar, then MATLAB uses the string defined by `DisplayName`.
- To add a legend programmatically that uses the `DisplayName` string, call `legend` with the `toggle` or `show` option.

See “Control Legend Content” for more information and examples.

The following code shows how to use the `DisplayName` property from the command line or in a file.

```
t = 0:.1:2*pi;
a(:,1)=sin(t); a(:,2)=cos(t);
h = plot(a);
set(h,{'DisplayName'},{'Sine','Cosine'})
legend show
```

## EraseMode

{normal} | none | xor | background

*Erase mode.* Controls the technique MATLAB uses to draw and erase line objects. Alternative erase modes are useful for creating animated sequences, where control of the way individual objects are redrawn is necessary to improve performance and obtain the desired effect.

- **normal** — Redraw the affected region of the display, performing the three-dimensional analysis necessary to ensure that all objects are rendered correctly. This mode produces the most accurate picture, but is the slowest. The other modes are faster, but do not perform a complete redraw and are therefore less accurate.
- **none** — Do not erase the line when it is moved or destroyed. While the object is still visible on the screen after erasing with `EraseMode none`, you cannot print it, because MATLAB stores no information about its former location.
- **xor** — Draw and erase the line by performing an exclusive OR (XOR) with the color of the screen beneath it. This mode does not damage the color of the objects beneath the line. However, the line’s color depends on the color of whatever is beneath it on the display.
- **background** — Erase the line by drawing it in the axes `background Color`, or the figure `background Color` if the axes

# Line Properties

---

Color is none. This damages objects that are behind the erased line, but lines are always properly colored.

## Printing with Nonnormal Erase Modes

MATLAB always prints figures as if the `EraseMode` of all objects is `normal`. This means graphics objects created with `EraseMode` set to `none`, `xor`, or `background` can look different on screen than on paper. On screen, MATLAB mathematically combines layers of colors (for example, performing an XOR on a pixel color with that of the pixel behind it) and ignore three-dimensional sorting to obtain greater rendering speed. However, these techniques are not applied to the printed output.

You can use the `getframe` command or other screen capture applications to create an image of a figure containing nonnormal mode objects.

### HandleVisibility

`{on} | callback | off`

*Control access to object handle.* Determine when an object's handle is visible in its parent's list of children. `HandleVisibility` is useful for preventing command-line users from accidentally drawing into or deleting a figure that contains only user interface devices (such as a dialog box).

- `on` — Handles are always visible.
- `callback` — Handles are visible from within callback routines or functions invoked by callback routines, but not from within functions invoked from the command line. This provides a means to protect GUIs from command-line users, while allowing callback routines to have access to object handles.
- `off` — Handles are invisible at all times. Use this option when a callback invokes a function that could damage the GUI (such as evaluating a user-typed string). This option temporarily hides its own handles during the execution of that function.

When a handle is not visible in its parent's list of children, it cannot be returned by functions that obtain handles by searching the object hierarchy or querying handle properties. This includes `get`, `findobj`, `gca`, `gcf`, `gco`, `newplot`, `cla`, `clf`, and `close`.

When a handle's visibility is restricted using `callback` or `off`, the object's handle does not appear in its parent's `Children` property, figures do not appear in the root's `CurrentFigure` property, objects do not appear in the root's `CallbackObject` property or in the figure's `CurrentObject` property, and axes do not appear in their parent's `CurrentAxes` property.

You can set the root `ShowHiddenHandles` property to `on` to make all handles visible regardless of their `HandleVisibility` settings (this does not affect the values of the `HandleVisibility` properties).

Handles that are hidden are still valid. If you know an object's handle, you can `set` and `get` its properties, and pass it to any function that operates on handles.

For more information, see “`HandleVisibility` Property”, “`Functions Affected by Handle Visibility`”, and “`Properties Affected by Handle Visibility`”.

`HitTest`  
`{on} | off`

*Selectable by mouse click.* Determines if the line can become the current object (as returned by the `gco` command and the figure `CurrentObject` property) as a result of a mouse click on the line. If `HitTest` is `off`, clicking the line selects the object below it (which might be the axes containing it).

`Interruptible`  
`off | {on}`

*Callback routine interruption*

# Line Properties

---

Controls whether MATLAB can interrupt an object's callback function when subsequent callbacks attempt to interrupt it.

For Graphics objects, the `Interruptible` property affects only the callbacks for the `ButtonDownFcn` property. A *running* callback is the currently executing callback. The *interrupting* callback is the callback that tries to interrupt the *running* callback. MATLAB handles both the callbacks based on the `Interruptible` property of the object of the *running* callback.

When the `Interruptible` property is set to:

- 'off', MATLAB finishes execution of the *running* callback without any interruptions
- 'on', these conditions apply:
  - If there is a `drawnow`, `figure`, `getframe`, `waitfor`, or `pause` command in the *running* callback, then MATLAB executes the *interrupting* callbacks which are already in the queue and returns to finish execution of the current callback.
  - If one of the above functions is not in the *running* callback, then MATLAB finishes execution of the current callback without any interruption.

`BusyAction` property of the object of interrupting callback determines whether the callback should be ignored or should be put in the queue.

Setting `Interruptible` property to on (default), allows a callback from other graphics objects to interrupt callback functions originating from this object.



---

**Note** MATLAB does not save the state of properties or the display when an interruption occurs. For example, the handle returned by the `gca` or `gcf` command may be changed as another callback is executed.

---

After the function that interrupts a callback completes, the callback resumes execution where it halted when interrupted. For more information, see “Control Callback Execution and Interruption”.

`LineStyle`

{-} | -- | : | -. | none

*Line style.*

## Line Style Specifiers Table

Specifier	Line Style
'-'	Solid line (default)
'--'	Dashed line
':'	Dotted line
'-.'	Dash-dot line
'none'	No line

Use `LineStyle none` when you want to place a marker at each point but do not want the points connected with a line (see the `Marker` property).

`LineWidth`

scalar

*Width of the line* . Specify this value in points. The default value is 0.5 points.

# Line Properties

## Marker

character (see table)

*Marker symbol.* Specifies marks displayed at data points. You can set values for the Marker property independently from the LineStyle property. For a list of supported marker symbols, see the following table.

**Marker Specifiers Table**

Specifier	Marker Type
'+'	Plus sign
'o'	Circle
'*'	Asterisk
'.'	Point
'x'	Cross
'square' or 's'	Square
'diamond' or 'd'	Diamond
'^'	Upward-pointing triangle
'v'	Downward-pointing triangle
'>'	Right-pointing triangle
'<'	Left-pointing triangle
'pentagram' or 'p'	Five-pointed star (pentagram)
'hexagram' or 'h' 'H'	Six-pointed star (hexagram)
'none'	No marker (default)

## MarkerEdgeColor

ColorSpec | none | {auto}

*Marker edge color.* The color of the marker or the edge color for filled markers (circle, square, diamond, pentagram, hexagram, and the four triangles).

- `ColorSpec` — User-defined color.
- `none` — Specifies no color, which makes nonfilled markers invisible.
- `auto` — Use same color as the line `Color` property.

`MarkerFaceColor`

`ColorSpec` | `{none}` | `auto`

*Fill color for closed-shape markers.* The fill color for markers that are closed shapes (circle, square, diamond, pentagram, hexagram, and the four triangles).

- `ColorSpec` — User-defined color.
- `none` — Makes the interior of the marker transparent, allowing the background to show through.
- `auto` — Sets the fill color to the axes `Color` property. If the axes `Color` property is `none`, sets the fill color to the figure `Color`.

`MarkerSize`

scalar

*Marker size.* Size of the marker in points. The default value is 6.

---

**Note** MATLAB draws the point marker (specified by the `'.'` symbol) at one-third the specified size.

---

`Parent`

handle of axes, `hggroup`, or `hgtransform`

# Line Properties

---

*Parent of line object.* Handle of the line object's parent. The parent of a line object is the axes that contains it. You can reparent line objects to other axes, hggroup, or hgtransform objects.

## Selected

on | off

*Selection status* When this property is on, MATLAB displays selection handles if the SelectionHighlight property is also on. You can, for example, define the ButtonDownFcn to set this property, allowing users to select the object with the mouse.

## SelectionHighlight

{on} | off

*Object highlighted when selected.* When the Selected property is on, MATLAB indicates the selected state by drawing handles at each vertex. When SelectionHighlight is off, MATLAB does not draw the handles.

## Tag

string

*User-specified object label.* Provides a means to identify graphics objects with a user-specified label. The default is an empty string.

Use this property when constructing interactive graphics programs that would otherwise need to define object handles as global variables or pass them as arguments between callbacks. You can define Tag as any string.

Use the Tag property and the findobj function to manipulate specific objects within a plotting hierarchy.

## Type

string (read-only)

*Class of graphics object.* String that identifies the class of the graphics object. Use this property to find all objects of a given type within a plotting hierarchy. For line objects, Type is always 'line'.

## UIContextMenu

handle of uicontextmenu object

*Associate context menu with line.* Assign this property the handle of a uicontextmenu object created in the same figure as the line. Use the uicontextmenu function to create the context menu. MATLAB displays the context menu whenever you right-click over the line.

## UserData

matrix

*User-specified data.* Data you want to associate with the line object. The default value is an empty array. MATLAB does not use this data, but you can access it using the set and get commands.

---

**Note** Setting the UserData property more than once erases previous entries.

---

## Visible

{on} | off

*Line visibility.*

- on — All lines are visible.
- off — Line is not visible, but still exists, and you can get and set its properties.

## XData

vector

# Line Properties

---

*x-coordinates of line.* Vector of *x*-coordinates defining the line. The default is [0 1].

YData and ZData, if set, must be the same length and have the same number of rows.

Create a line using the `line` function, then change its XData property:

```
mylin = line(rand(1,10),rand(1,10));
set(mylin,'XData',rand(1,15));
% A warning because you did not set YData
set(mylin,'XData',rand(1,15),...
 'YData',rand(1,15));
% No warning appears and the plot draws as expected.
```

## YData

vector

*y-coordinates of line.* Vector of *y*-coordinates defining the line. The default is [0 1]. XData and ZData, if set, must be the same length and have the same number of rows.

Create a line using the `line` function, then change its YData property:

```
mylin = line(rand(1,10),rand(1,10));
set(mylin,'YData',rand(1,15));
% A warning because you did not set YData
set(mylin,'YData',rand(1,15),'XData',rand(1,15));
% No warning appears and the plot draws as expected.
```

## ZData

vector

*z-coordinates of line.* Vector of *z*-coordinates defining the line. The default is [] (empty). XData and YData must have the same number of rows.

Create a line using the `line` function, then change its ZData property:

```
mylin = line(rand(1,10),rand(1,10),rand(1,10));
view(3)
set(mylin,'ZData',rand(1,15));
% A warning because you did not set YData
set(mylin,'XData',rand(1,15),...
 'YData',rand(1,15),...
 'ZData',rand(1,15));
% No warning appears and the plot draws as expected.
```

**See Also**      [line](#)

# Lineseries Properties

---

## Purpose

Description of lineseries properties

## Modifying Properties

You can set and query graphics object properties using the `set` and `get` commands or with the property editor (`propertyeditor`).

See “Plot Objects” for more information on lineseries objects.

Note that you cannot define default properties for lineseries objects.

## Lineseries Property Descriptions

This section lists property names along with the type of values each accepts. Curly braces `{ }` enclose default values.

Annotation

`hg.Annotation` object (read-only)

*Control the display of lineseries objects in legends.* Specifies whether this lineseries object is represented in a figure legend.

Querying the `Annotation` property returns the handle of an `hg.Annotation` object. The `hg.Annotation` object has a property called `LegendInformation`, which contains an `hg.LegendEntry` object.

Once you have obtained the `hg.LegendEntry` object, you can set its `IconDisplayStyle` property to control whether the lineseries object is displayed in a figure legend.

IconDisplayStyle Value	Purpose
on	Include the lineseries object in a legend as one entry, but not its children objects
off	Do not include the lineseries or its children in a legend (default)
children	Include only the children of the lineseries as separate entries in the legend



## Setting the IconDisplayStyle Property

These commands set the `IconDisplayStyle` of a graphics object with handle `hobj` to `children`, which causes each child object to have an entry in the legend:

```
hAnnotation = get(hobj, 'Annotation');
hLegendEntry = get(hAnnotation, 'LegendInformation');
set(hLegendEntry, 'IconDisplayStyle', 'children')
```

## Using the IconDisplayStyle Property

See “Control Legend Content” for more information and examples.

### BeingDeleted

`on` | `{off}` (read-only)

*This object is being deleted.* Mechanism to determine if objects are in the process of being deleted. MATLAB sets the `BeingDeleted` property to `on` when the object’s delete function callback is called (see the `DeleteFcn` property). It remains set to `on` while the delete function executes, after which the object no longer exists.

For example, an object’s delete function calls other functions that act on a number of different objects. If a function does not need to perform an action on an about-be-deleted object, it can check the object’s `BeingDeleted` property before acting.

### BusyAction

`cancel` | `{queue}`

*Callback queuing*

Determines how MATLAB handles the execution of interrupting callbacks.

A *running* callback is the currently executing callback. The *interrupting* callback is the callback that tries to interrupt the

# Lineseries Properties

---

*running* callback. The `BusyAction` property of the *interrupting* callback determines how MATLAB handles its execution. When the `BusyAction` property is set to:

- 'queue' — Puts the *interrupting* callback in a queue to be processed after the *running* callback finishes execution.
- 'cancel' — Discards the *interrupting* callback as MATLAB finishes execution.

For information about how the `Interruptible` property of the callback controls whether other callbacks can interrupt the *running* callback, see the `Interruptible` property description.

`ButtonDownFcn`  
string | function handle

*Button press callback function.* Executes whenever you press a mouse button while the pointer is over this object, but not over another graphics object.

See the figure's `SelectionType` property to determine if modifier keys were also pressed.

This property can be:

- A string that is a valid MATLAB expression
- The name of a MATLAB file
- A function handle

Set this property to a function handle that references the callback. The expressions execute in the MATLAB workspace.

For information on the syntax of callback functions, see `Function Handle Callbacks`.

`Children`  
vector of handles

The empty matrix; line objects have no children.

## Clipping

{on} | off

*Clipping mode.* MATLAB clips graphs to the axes plot box by default. If you set `Clipping` to `off`, portions of graphs appear outside the axes plot box. This occurs if you create a plot object, set `hold` to `on`, freeze axis scaling (`axis manual`), and then create a larger plot object.

## Color

ColorSpec

*Color of the object.* A three-element RGB vector or one of the MATLAB predefined names, specifying the object's color. The default value is `[0 0 0]` (black).

See the `ColorSpec` reference page for more information on specifying color. See “Adding Arrows and Lines to Graphs”.

## CreateFcn

function handle | cell array containing function handle and additional arguments | string (not recommended)

*Callback function executed during object creation.* Defines a callback that executes when MATLAB creates an object. The default is an empty array.

You must specify the callback during the creation of the object. For example:

```
graphicfcn(y, 'CreateFcn', @CallbackFcn)
```

where `@CallbackFcn` is a function handle that references the callback function and `graphicfcn` is the plotting function which creates this object.

# Lineseries Properties

---

MATLAB executes this routine after setting all other object properties. Setting this property on an existing object has no effect.

The handle of the object whose `CreateFcn` is being executed is accessible only through the root `CallbackObject` property, which you can query using `gcbo`.

For information on the syntax of callback functions, see [Function Handle Callbacks](#).

## `DeleteFcn`

function handle | cell array containing function handle and additional arguments | string (not recommended)

*Callback executed during object deletion.* Executes when this object is deleted (for example, this might happen when you issue a `delete` command on the object, its parent axes, or the figure containing it). MATLAB executes the callback before destroying the object's properties so the callback routine can query these values. The default is an empty array.

The handle of the object whose `DeleteFcn` is being executed is accessible only through the root `CallbackObject` property, which can be queried using `gcbo`.

For information on the syntax of callback functions, see [Function Handle Callbacks](#).

See the `BeingDeleted` property for related information.

## `DisplayName`

string

*String used by legend.* The `legend` function uses the `DisplayName` property to label the lineseries object in the legend. The default is an empty string.

- If you specify string arguments with the `legend` function, MATLAB set `DisplayName` to the corresponding string and uses that string for the legend.
- If `DisplayName` is empty, `legend` creates a string of the form, `['data' n]`, where `n` is the number assigned to the object based on its location in the list of legend entries. However, `legend` does not set `DisplayName` to this string.
- If you edit the string directly in an existing legend, MATLAB set `DisplayName` to the edited string.
- If you specify a string for the `DisplayName` property and create the legend using the figure toolbar, then MATLAB uses the string defined by `DisplayName`.
- To add a legend programmatically that uses the `DisplayName` string, call `legend` with the `toggle` or `show` option.

See “Control Legend Content” for more information and examples.

## EraseMode

`{normal} | none | xor | background`

*Erase mode.* Controls the technique MATLAB uses to draw and erase objects. Use alternative erase modes for creating animated sequences, where control of the way individual objects are redrawn is necessary to improve performance and obtain the desired effect.

- `normal` — Redraw the affected region of the display, performing the three-dimensional analysis necessary to correctly render all objects. This mode produces the most accurate picture, but is the slowest. The other modes are faster, but do not perform a complete redraw and are therefore less accurate.
- `none` — Do not erase the object when it is moved or destroyed. While the object is still visible on the screen after erasing with `EraseMode none`, you cannot print it because MATLAB stores no information about its former location.

# Lineseries Properties

---

- `xor` — Draw and erase the object by performing an exclusive OR (XOR) with the color of the screen beneath it. This mode does not damage the color of the objects beneath it. However, the object's color depends on the color of whatever is beneath it on the display.
- `background` — Erase the object by redrawing it in the axes background `Color`, or the figure background `Color` if the axes `Color` property is `none`. This damages objects that are behind the erased object, but properly colors the erased object.

Set the axes background color with the axes `Color` property. Set the figure background color with the figure `Color` property.

## Printing with Nonnormal Erase Modes

MATLAB always prints figures as if the `EraseMode` of all objects is `normal`. This means graphics objects created with `EraseMode` set to `none`, `xor`, or `background` can look different on screen than on paper. On screen, MATLAB mathematically combines layers of colors (for example, performing an XOR on a pixel color with that of the pixel behind it) and ignore three-dimensional sorting to obtain greater rendering speed. However, these techniques are not applied to the printed output.

You can use the `getframe` command or other screen capture applications to create an image of a figure containing nonnormal mode objects.

`HandleVisibility`  
{on} | callback | off

*Control access to object's handle.* Determines when an object's handle is visible in its parent's list of children. `HandleVisibility` is useful for preventing command-line users from accidentally accessing objects that you need to protect for some reason.

- `on` — Handles are always visible.

- **callback** — Handles are visible from within callback routines or functions invoked by callback routines, but not from within functions invoked from the command line. This provides a means to protect GUIs from command-line users, while allowing callback routines to have access to object handles.
- **off** — Handles are invisible at all times. Use this option when a callback invokes a function that could damage the GUI (such as evaluating a user-typed string). This option temporarily hides its own handles during the execution of that function.

## Functions Affected by Handle Visibility

When a handle is not visible in its parent's list of children, it cannot be returned by functions that obtain handles by searching the object hierarchy or querying handle properties. This includes `get`, `findobj`, `gca`, `gcf`, `gco`, `newplot`, `cla`, `clf`, and `close`.

## Properties Affected by Handle Visibility

When a handle's visibility is restricted using `callback` or `off`, the object's handle does not appear in its parent's `Children` property, figures do not appear in the root's `CurrentFigure` property, objects do not appear in the root's `CallbackObject` property or in the figure's `CurrentObject` property, and axes do not appear in their parent's `CurrentAxes` property.

## Overriding Handle Visibility

You can set the root `ShowHiddenHandles` property to `on` to make all handles visible regardless of their `HandleVisibility` settings. This does not affect the values of the `HandleVisibility` properties. See also `findall`.

## Handle Validity

# Lineseries Properties

---

Hidden handles are still valid. If you know an object's handle, you can `set` and `get` its properties and pass it to any function that operates on handles.

---

**Note** If you change one data source property to a variable that contains data of a different dimension, you might cause the function to generate a warning and not render the graph until you have changed all data source properties to appropriate values.

---

`HitTest`  
`{on} | off`

*Selectable by mouse click.* Determines whether this object can become the current object (as returned by the `gco` command and the figure `CurrentObject` property) as a result of a mouse click on the line. If `HitTest` is `off`, clicking this object selects the object below it (which is usually the axes containing it).

`Interruptible`  
`off | {on}`

*Callback routine interruption*

Controls whether MATLAB can interrupt an object's callback function when subsequent callbacks attempt to interrupt it.

For Graphics objects, the `Interruptible` property affects only the callbacks for the `ButtonDownFcn` property. A *running* callback is the currently executing callback. The *interrupting* callback is the callback that tries to interrupt the *running* callback. MATLAB handles both the callbacks based on the `Interruptible` property of the object of the *running* callback.

When the `Interruptible` property is set to:



- 'off', MATLAB finishes execution of the *running* callback without any interruptions
- 'on', these conditions apply:
  - If there is a *drawnow*, *figure*, *getframe*, *waitfor*, or *pause* command in the *running* callback, then MATLAB executes the *interrupting* callbacks which are already in the queue and returns to finish execution of the current callback.
  - If one of the above functions is not in the *running* callback, then MATLAB finishes execution of the current callback without any interruption.

`BusyAction` property of the object of interrupting callback determines whether the callback should be ignored or should be put in the queue.

Setting `Interruptible` property to on (default), allows a callback from other graphics objects to interrupt callback functions originating from this object.

---

**Note** MATLAB does not save the state of properties or the display when an interruption occurs. For example, the handle returned by the `gca` or `gcf` command may be changed as another callback is executed.

---

After the function that interrupts a callback completes, the callback resumes execution where it halted when interrupted. For more information, see “Control Callback Execution and Interruption”.

`LineStyle`

{-} | -- | : | -. | none

*Line style of lineseries object.*

# Lineseries Properties

---

**Line Style Specifiers Table**

Specifier	Line Style
'-'	Solid line (default)
'--'	Dashed line
'.'	Dotted line
'-.'	Dash-dot line
'none'	No line

Use `LineStyle none` when you want to place a marker at each point but do not want the points connected with a line (see the `Marker` property).

**LineWidth**

size in points

*Width of linear objects and edges of filled areas.* Specify in points. 1 point =  $1/72$  inch. The default is 0.5 points.

**Marker**

character (see table)

*Marker symbol.* Specifies marks that display at data points. You can set values for the `Marker` property independently from the `LineStyle` property. For a list of supported marker symbols, see the following table.

**Marker Specifiers Table**

Specifier	Marker Type
'+'	Plus sign
'o'	Circle
'*'	Asterisk

Specifier	Marker Type
'.'	Point
'x'	Cross
'square' or 's'	Square
'diamond' or 'd'	Diamond
'^'	Upward-pointing triangle
'v'	Downward-pointing triangle
'>'	Right-pointing triangle
'<'	Left-pointing triangle
'pentagram' or 'p'	Five-pointed star (pentagram)
'hexagram' or 'h' ' '	Six-pointed star (hexagram)
'none'	No marker (default)

## MarkerEdgeColor

ColorSpec | none | {auto}

*Marker edge color.* The color of the marker or the edge color for filled markers (circle, square, diamond, pentagram, hexagram, and the four triangles).

- `ColorSpec` — User-defined color.
- `none` — Specifies no color, which makes nonfilled markers invisible.
- `auto` — Uses same color as the `Color` property.

## MarkerFaceColor

ColorSpec | {none} | auto

*Fill color for closed-shape markers.* The fill color for markers that are closed shapes (circle, square, diamond, pentagram, hexagram, and the four triangles).

# Lineseries Properties

---

- `ColorSpec` — User-defined color.
- `none` — Makes the interior of the marker transparent, allowing the background to show through.
- `auto` — Sets the fill color to the axes `Color` property. If the axes `Color` property is `none`, sets the fill color to the figure `Color`.

`MarkerSize`  
scalar

*Marker size.* Size of the marker in points. The default value is 6.

---

**Note** MATLAB draws the point marker (specified by the `'.'` symbol) at one-third the specified size.

---

`Parent`

handle of parent axes, `hgggroup`, or `hgtransform`

*Parent of object.* Handle of the object's parent. The parent is normally the axes, `hgggroup`, or `hgtransform` object that contains the object.

`Selected`

`on` | `{off}`

*Object selection state.* When you set this property to `on`, MATLAB displays selection handles at the corners and midpoints if the `SelectionHighlight` property is also `on` (the default). You can, for example, define the `ButtonDownFcn` callback to set this property to `on`, thereby indicating that this particular object is selected. This property is also set to `on` when an object is manually selected in plot edit mode.

`SelectionHighlight`

`{on}` | `off`

*Object highlighted when selected.*

- **on** — MATLAB indicates the selected state by drawing four edge handles and four corner handles.
- **off** — MATLAB does not draw the handles except when in plot edit mode and objects are selected manually.

Tag

string

*User-specified object label.* Provides a means to identify graphics objects with a user-specified label. The default is an empty string.

Use the `Tag` property and the `findobj` function to manipulate specific objects within a plotting hierarchy.

For example, create an `areaseries` object and set the `Tag` property.

```
t = area(Y, 'Tag', 'area1')
```

When you want to access objects of a given type, use `findobj` to find the object's handle. The following statement changes the `FaceColor` property of the object whose `Tag` is `area1`.

```
set(findobj('Tag', 'area1'), 'FaceColor', 'red')
```

Type

string (read-only)

*Class of graphics object.* String that identifies the class of the graphics object. Use this property to find all objects of a given type within a plotting hierarchy. For `lineseries` objects, `Type` is always the string `line`.

UIContextMenu

handle of `uicontextmenu` object

*Associate context menu with object.* Handle of a `uicontextmenu` object created in the object's parent figure. Use the `uicontextmenu`

# Lineseries Properties

---

function to create the context menu. MATLAB displays the context menu whenever you right-click over the object. The default value is an empty array.

UserData  
array

*User-specified data.* Data you want to associate with this object (including cell arrays and structures). The default value is an empty array. MATLAB does not use this data, but you can access it using the `set` and `get` commands.

Visible  
{on} | off

*Visibility of object and its children.*

- **on** — Object and all children of the object are visible unless the child object's `Visible` property is `off`.
- **off** — Object not displayed. However, the object still exists and you can set and query its properties.

XData  
vector | matrix

*x-axis values for graph.* The *x*-axis values for graphs are specified by the `X` input argument. If `XData` is a vector, `length(XData)` must equal `length(YData)` and must be monotonic. If `XData` is a matrix, `size(XData)` must equal `size(YData)` and each column must be monotonic.

You can use `XData` to define meaningful coordinates for an underlying surface whose topography is being mapped.

XDataMode  
{auto} | manual

*Use automatic or user-specified x-axis values.* If you specify `XData` (by setting the `XData` property or specifying the `X` input

argument), MATLAB sets this property to `manual` and uses the specified values to label the  $x$ -axis.

If you set `XDataMode` to `auto` after specifying `XData`, MATLAB resets the  $x$ -axis ticks to `1:size(YData,1)` or to the column indices of the `ZData`, overwriting any previous values for `XData`.

## `XDataSource`

MATLAB variable, as a string

*Link `XData` to MATLAB variable.* Set this property to a MATLAB variable that is evaluated in the base workspace to generate the `XData`. The default value is an empty array.

```
set(h, 'XDataSource', 'xdatabasename')
```

MATLAB requires a call to `refreshdata` when you set this property. Changing workspace variables used as an object's `XDataSource` does not change the object's `XData` values, but you can use `refreshdata` to force an update of the object's data. `refreshdata` also lets you specify that the data source variable be evaluated in the workspace of a function from which you call `refreshdata`.

---

**Note** If you change one data source property to a variable that contains data of a different dimension, you might cause the function to generate a warning and not render the graph until you have changed all data source properties to appropriate values.

---

## `YData`

vector | matrix

*Y-coordinates.* A vector of  $y$ -coordinates defining the values along the  $y$ -axis for the graph. `XData` and `ZData` must be the same length and have the same number of rows.

# Lineseries Properties

---

## YDataSource

MATLAB variable, as a string

*Link YData to MATLAB variable.* Set this property to a MATLAB variable that is evaluated in the base workspace to generate the YData. The default value is an empty array.

```
set(h, 'YDataSource', 'Ydatavariablename')
```

MATLAB requires a call to `refreshdata` when you set this property. Changing workspace variables used as an object's YDataSource does not change the object's YData values, but you can use `refreshdata` to force an update of the object's data. `refreshdata` also lets you specify that the data source variable be evaluated in the workspace of a function from which you call `refreshdata`.

---

**Note** If you change one data source property to a variable that contains data of a different dimension, you might cause the function to generate a warning and not render the graph until you have changed all data source properties to appropriate values.

---

## ZData

vector

*Z-coordinates.* A vector defining the *z*-coordinates for the graph. XData and YData must be the same length and have the same number of rows.

## ZDataSource

MATLAB variable, as a string

*Link ZData to MATLAB variable.* Set this property to a MATLAB variable that is evaluated in the base workspace to generate the ZData. The default value is an empty array.



```
set(h, 'ZDataSource', 'zdatavariablename')
```

MATLAB requires a call to `refreshdata` when you set this property. Changing workspace variables used as an object's `ZDataSource` does not change the object's `ZData` values, but you can use `refreshdata` to force an update of the object's data. `refreshdata` also lets you specify that the data source variable be evaluated in the workspace of a function from which you call `refreshdata`.

---

**Note** If you change one data source property to a variable that contains data of a different dimension, you might cause the function to generate a warning and not render the graph until you have changed all data source properties to appropriate values.

---

# LineStyle (Line Specification)

---

**Purpose** Line specification string syntax

**Description** Plotting functions accept *string specifiers* as arguments and modify the graph generated accordingly. Three components can be specified in the *string specifiers* along with the plotting command. They are:

- Line style
- Marker symbol
- Color

For example:

```
plot(x,y, '-or')
```

plots y versus x using a dash-dot line (-.), places circular markers (o) at the data points, and colors both line and marker red (r). Specify the components (in any order) as a quoted string after the data arguments. Note that linespecs are single strings, not property-value pairs.

## Plotting Data Points with No Line

If you specify a marker, but not a line style, only the markers are plotted. For example:

```
plot(x,y, 'd')
```

## Line Style Specifiers

You indicate the line styles, marker types, and colors you want to display using *string specifiers*, detailed in the following tables:

Specifier	LineStyle
'_'	Solid line (default)
'--'	Dashed line

## LineStyle (Line Specification)

---

Specifier	LineStyle
'.'	Dotted line
'-.'	Dash-dot line

### Marker Specifiers

Specifier	Marker Type
'+'	Plus sign
'o'	Circle
'*'	Asterisk
'.'	Point
'x'	Cross
'square' or 's'	Square
'diamond' or 'd'	Diamond
'^'	Upward-pointing triangle
'v'	Downward-pointing triangle
'>'	Right-pointing triangle
'<'	Left-pointing triangle
'pentagram' or 'p'	Five-pointed star (pentagram)
'hexagram' or 'h ' '	Six-pointed star (hexagram)

---

**Note** The point (.) marker type does not change size when the specified value is less than 5.

---

# LineStyle (Line Specification)

---

## Color Specifiers

Specifier	Color
r	Red
g	Green
b	Blue
c	Cyan
m	Magenta
y	Yellow
k	Black
w	White

## Related Properties

This page also describes how to specify the properties of lines used for plotting. MATLAB graphics give you control over these visual characteristics:

- **LineWidth** — Specifies the width (in points) of the line.
- **MarkerEdgeColor** — Specifies the color of the marker or the edge color for filled markers (circle, square, diamond, pentagram, hexagram, and the four triangles).
- **MarkerFaceColor** — Specifies the color of the face of filled markers.
- **MarkerSize** — Specifies the size of the marker in points (must be greater than 0).

In addition, you can specify the **LineStyle**, **Color**, and **Marker** properties instead of using the symbol string. This is useful if you want to specify a color that is not in the list by using RGB values. See **Lineseries Properties** for details on these properties and **ColorSpec** for more information on color.

## Examples

Plot the sine function over three different ranges using different line styles, colors, and markers.

## LineSpec (Line Specification)

```
figure
t = 0:pi/20:2*pi;
plot(t,sin(t),'-.r*')
hold on
plot(t,sin(t-pi/2),'--mo')
plot(t,sin(t-pi),':bs')
hold off
```

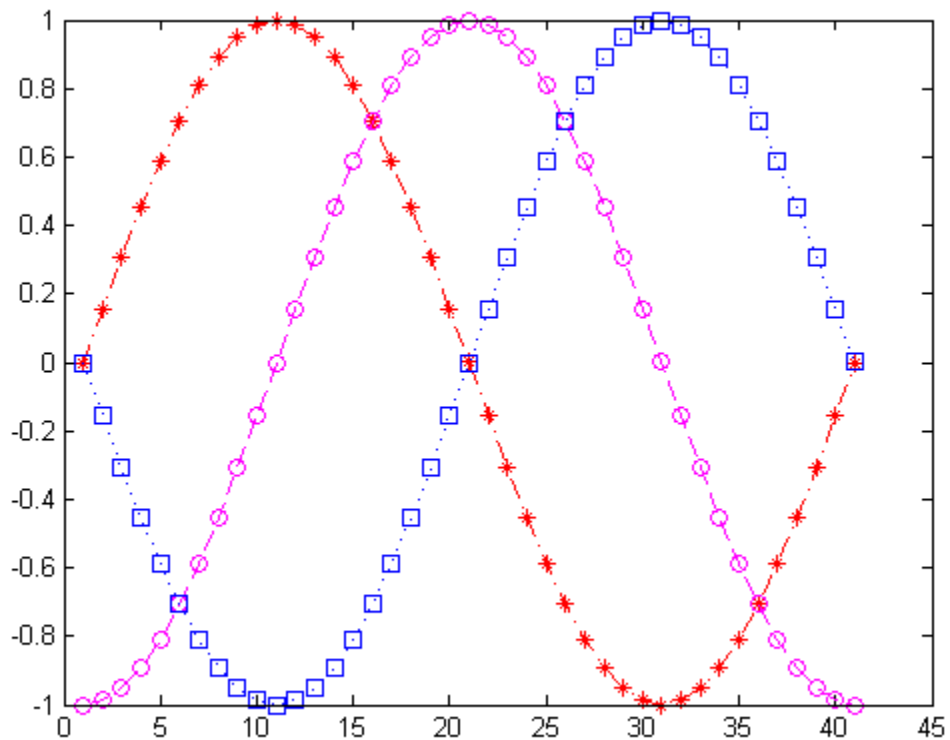

Create a plot illustrating how to set line properties:

# LineStyle (Line Specification)

---

```
figure
plot(t,sin(2*t),'-mo',...
 'LineWidth',2,...
 'MarkerEdgeColor','k',...
 'MarkerFaceColor',[.49 1 .63],...
 'MarkerSize',10)
```

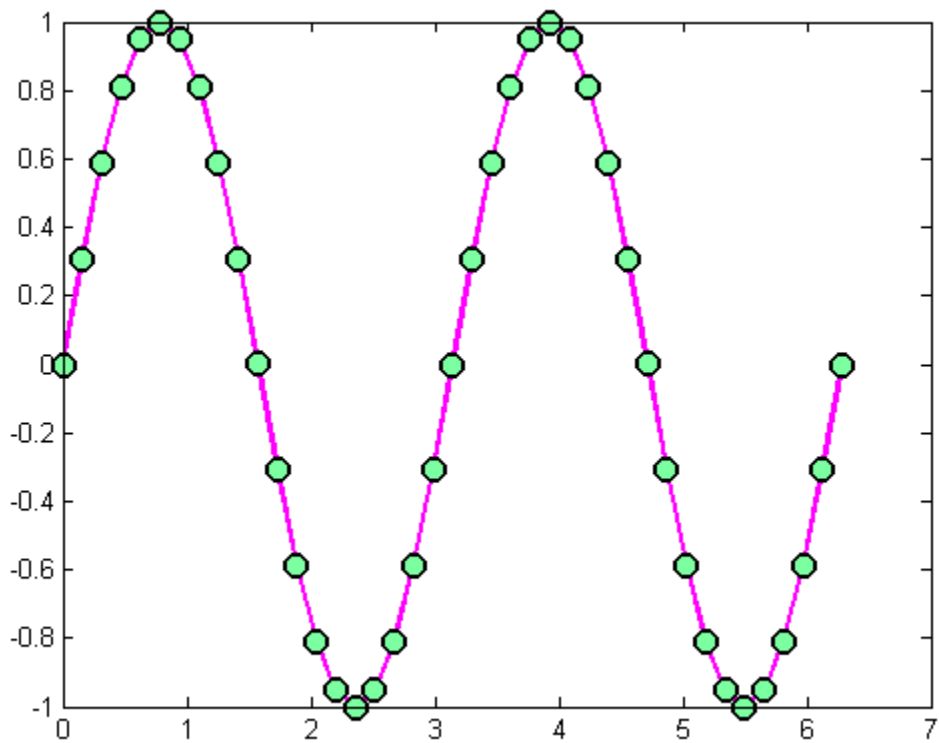

## See Also

[axes](#) | [line](#) | [plot](#) | [patch](#) | [set](#) | [surface](#) | [ColorSpec](#) | [Lineseries Properties](#)

**Purpose** Synchronize limits of specified 2-D axes

**Syntax** `linkaxes(axes_handles)`  
`linkaxes(axes_handles, 'option')`

**Description** Use `linkaxes` to synchronize the individual axis limits across several figures or subplots within a figure. Calling `linkaxes` makes all input axes have identical limits. Linking axes is best when you want to zoom or pan in one subplot and display the same range of data in another subplot.

`linkaxes(axes_handles)` links the *x*- and *y*-axis limits of the axes specified in the vector `axes_handles`. You can link any number of existing plots or subplots. The `axes_handles` input should be a vector of the handles for each plot or subplot. Entering an array of values results in an error message.

`linkaxes(axes_handles, 'option')` links the axes' `axes_handles` according to the specified option. The *option* argument can be one of the following strings:

<code>x</code>	Link <i>x</i> -axis only.
<code>y</code>	Link <i>y</i> -axis only.
<code>xy</code>	Link <i>x</i> -axis and <i>y</i> -axis.
<code>off</code>	Remove linking.

See the `linkprop` function for more advanced capabilities that allow you to link object properties on any graphics object.

**Tips** The first axes you supply to `linkaxes` determines the *x*- and *y*-limits for all linked axes. This can cause plots to partly or entirely disappear if their limits or scaling are very different. To override this behavior, after calling `linkaxes`, specify the limits of the axes that you want to control with the `set` command, as the third example illustrates.

---

**Note** `linkaxes` is not designed to be transitive across multiple invocations. If you have three axes, `ax1`, `ax2`, and `ax3` and want to link them together, call `linkaxes` with `[ax1, ax2, ax3]` as the first argument. Linking `ax1` to `ax2`, then `ax2` to `ax3`, "unbinds" the `ax1-ax2` linkage.

---

## Examples

You can use interactive zooming or panning (selected from the figure toolbar) to see the effect of axes linking. For example, pan in one graph and notice how the  $x$ -axis also changes in the other. The axes responds in the same way to `zoom` and `pan` directives you type in the Command Window.

This example loads three vectors of data and creates a subplot for each vector. After a three-second pause, it then calls `linkaxes` with the argument `'xy'` to synchronize both the  $x$  and  $y$  axes limits. By specifying the third subplot first to `linkaxes`, you establish its  $y$ -limit for all the subplots:

```
load count.dat % Contains a 3-column vector named count
figure
ax(1) = subplot(3,1,1);
bar(ax(1),count(:,1),'g');
ax(2) = subplot(3,1,2);
bar(ax(2),count(:,2),'b');
ax(3) = subplot(3,1,3);
bar(ax(3),count(:,3),'m');
```



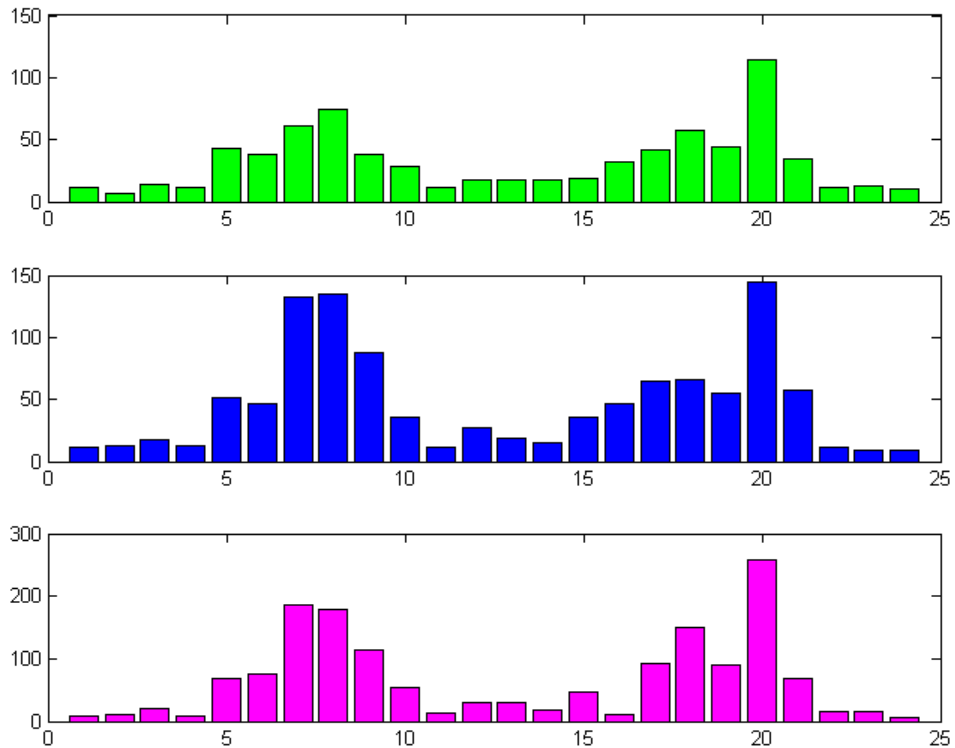



Base the y-axis limits on the bottom subplot.

```
% Wait three seconds and then link the axes
pause(3)
linkaxes([ax(3) ax(2) ax(1)], 'xy');
```

# linkaxes

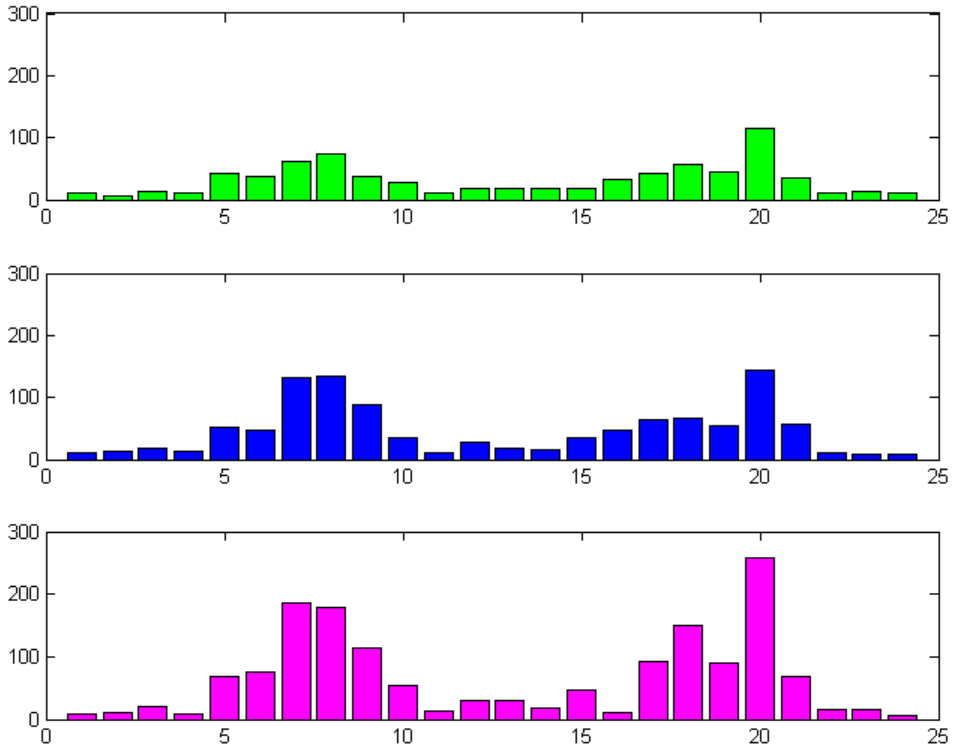
---



Click the **Zoom in** icon  to enter Zoom mode, and click the mouse near the middle of the top axes. You observe all three axes respond the same. If you pan in any of the axes, all of them also respond the same.

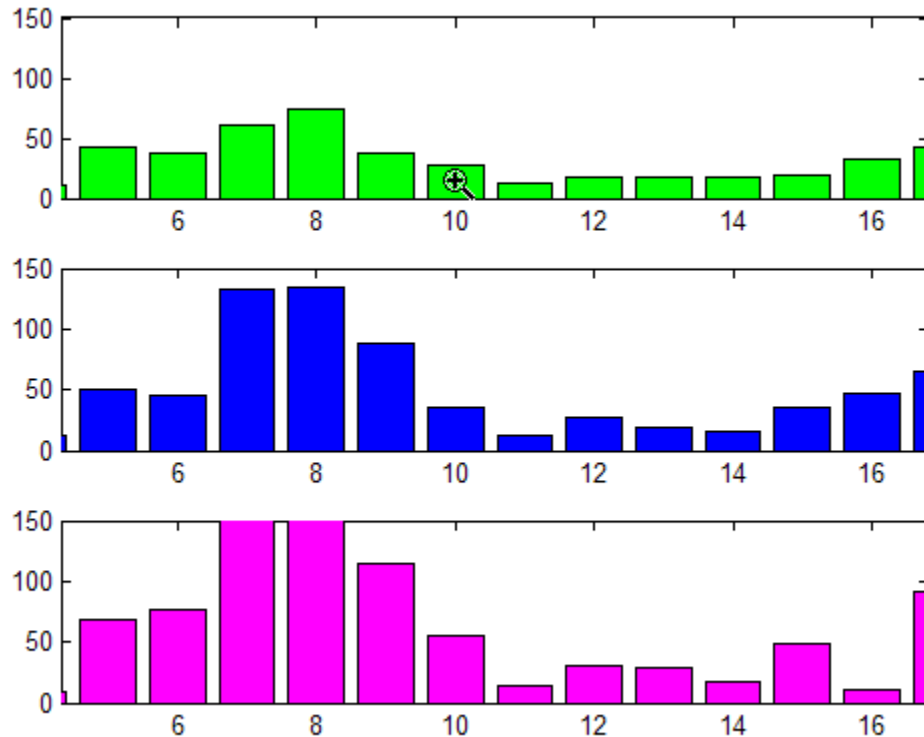

Create two subplots containing related bar graphs. Call `linkaxes` to link only the  $x$ -axis limits of the two axes. Unlike in the previous example, the  $y$ -limits of the graphs remain unchanged. The example shows the effect of restricting the  $x$ -values to a range of 5 units and then manually panning either subplot:

```
load count.dat
figure
ax(1) = subplot(2,1,1);
```

# linkaxes

---

```
bar(ax(1),count(:,1),'g');
ax(2) = subplot(2,1,2);
bar(ax(2),count(:,2),'b');
linkaxes(ax,'x');
% Restrict either axis to show 5 values
set(ax(1),'XLim',[4.5 9.5])
```

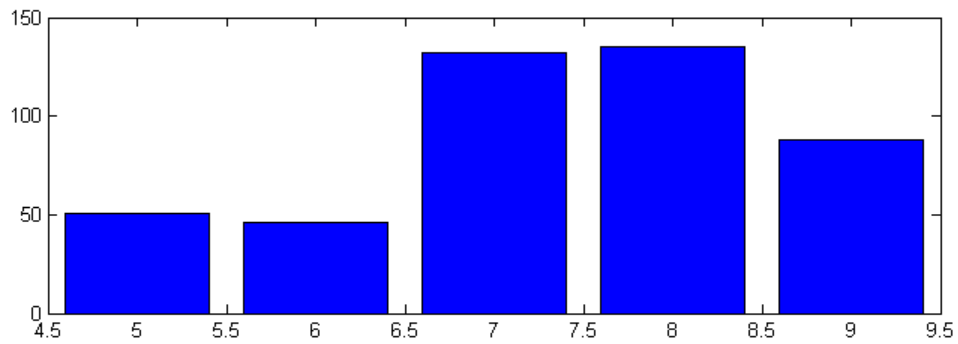
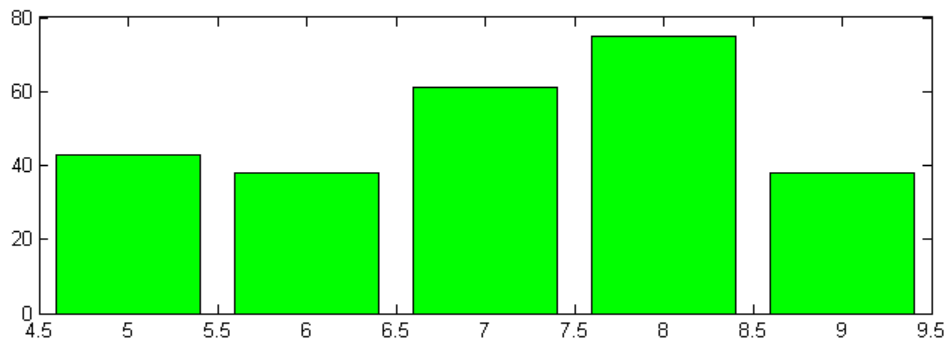

Choose the Pan tool (**Tools > Pan**) (or type `pan on`). Drag the top axes. Both axes pan uniformly in  $x$ , but only the one you pan moves in the  $y$  direction.

---

Create two subplots containing data having different ranges. The first axes handle passed to `linkaxes` determines the data range for all other linked axes. In this example, calling `set` for the lower axes overrides the  $x$ -limits established by the call to `linkaxes`:

```
a1 = subplot(2,1,1);

% Plot 10 numbers on top
plot(randn(10,1));
a2 = subplot(2,1,2);

% Plot 100 numbers below
plot(a2,randn(100,1))

% Link the axes; subplot 2 now out of range
linkaxes([a1 a2], 'x');
```

# linkaxes

---

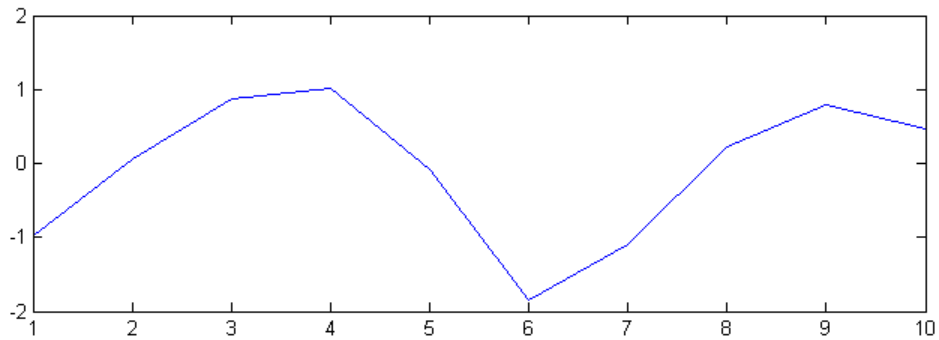
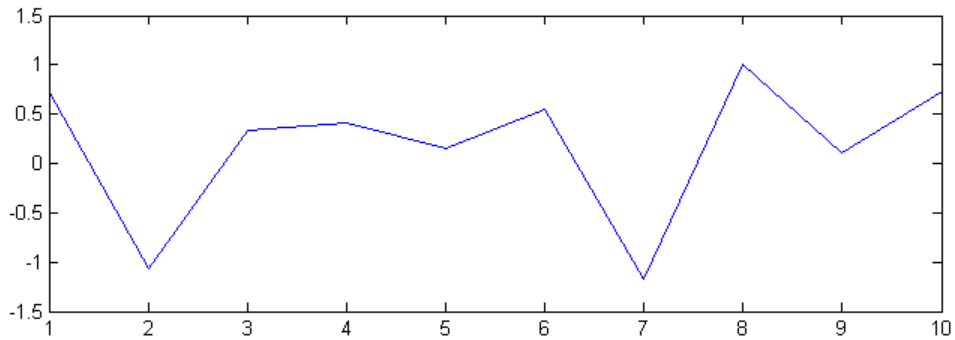

In order to display the full range of  $x$ -values, override the axes limits that `linkaxes` established.

```
set(a2, 'xlimmode', 'auto');
```

Now both  $x$ -axes run from 1 to 100. You could also use `set(a2, 'xlim', [1 100])`.

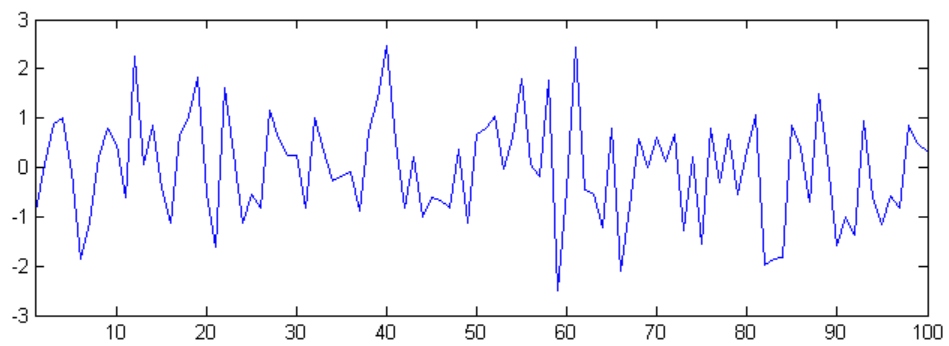
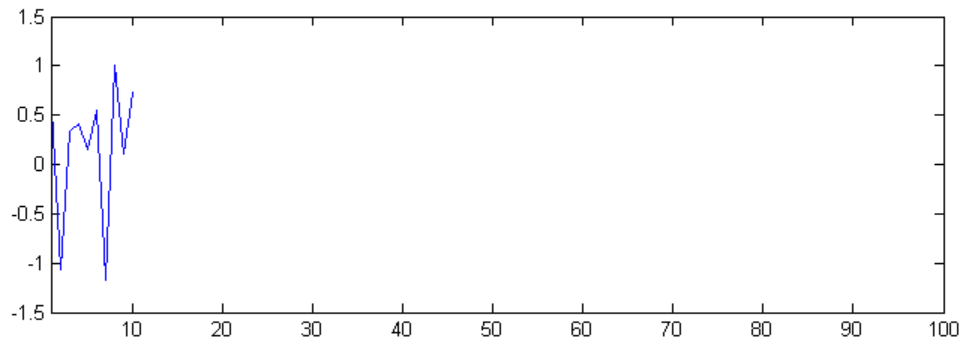

## See Also

[linkdata](#) | [linkprop](#) | [pan](#) | [zoom](#)

# linkdata

---

**Purpose** Automatically update graphs when variables change

**Syntax**

```
linkdata on
linkdata off
linkdata
linkdata(figure_handle,...)
linkobj = linkdata(figure_handle)
```

**Description** `linkdata on` turns on data linking for the current figure.

`linkdata off` turns data linking off.

`linkdata` by itself toggles the state of data linking.

`linkdata(figure_handle,...)` applies the function to the specified figure handle.

`linkobj = linkdata(figure_handle)` returns a *linkdata object* for the specified figure. The object has one read-only property, `Enable`, the string 'on' or 'off', depending on the linked state of the figure.

Data linking connects graphs in figure windows to variables in the base or a function's workspace via their `XDataSource`, `YDataSource`, and `ZDataSource` properties. When you turn on data linking for a figure, MATLAB compares variables in the current (base or function caller) workspace with the `XData`, `YData`, and `ZData` properties of graphs in the affected figure to try to match them. When a match is found, the appropriate `XDataSource`, `YDataSource` and/or `ZDataSource` for the graph are set to strings that name the matching variables.

Any subsequent changes to linked variables are reflected in graphs that use them as data sources and in the Variables editor, if the linked variables are displayed there. Conversely, any changes to plotted data values made at the command line, in the Variables editor, or with the Brush tool (such as deleting or replacing data points), are immediately reflected in the workspace variables linked to the data points.

When a figure containing graphs is linked and any variable identified as `XDataSource`, `YDataSource`, and/or `ZDataSource` changes its values in the workspace, all graphs displaying it in that and other linked figures



automatically update. This operation is equivalent to automatically calling the `refreshdata` function on the corresponding figure when a variable changes.

Linked figure windows identify themselves by the appearance of the Linked Plot information bar at the top of the window. When `linkdata` is off for a figure, the Linked Plot information bar is removed. If `linkdata` cannot unambiguously identify data sources for a graph in a linked figure, it reports this via the Linked Plot information bar, which gives the user an opportunity to identify data sources. The information bar displays a warning icon and a message, **No graphics have data sources** and also prompts **fix it**. Clicking **fix it** opens the Specify Data Source Properties dialog box for identifying variable names and ranges of data sources used in the graph.

## Tips

- “Types of Variables You Can Link” on page 1-3815
- “Restoring Links that Break” on page 1-3815
- “Linking Rapidly Changing Data” on page 1-3816
- “Linking Brushed Graphs” on page 1-3816

## Types of Variables You Can Link

You can use `linkdata` to connect a graph with scalar, vector and matrix numeric variables of any class (including `complex`, if the graphing function can plot it) — essentially any data for which `isnumeric` equals `true`. See “Example 3” on page 1-3819 for instructions on linking complex variables. You can also link plots to numeric fields within structures. You can specify MATLAB expressions as data sources, for example, `sqrt(y)+1`.

## Restoring Links that Break

Refreshing data on a linked plot fails if the strings in the `XDataSource`, `YDataSource`, or `ZDataSource` properties, when evaluated, are incompatible with what is in the current workspace, such that the corresponding `XData`, `YData`, or `ZData` are unable to respond. The visual appearance of the object in the graph is not affected by such failures, so graphic objects show no indication of broken links. Instead,

a warning icon and the message **Failing links** appear on the Linked Plot information bar along with an **Edit** button that opens the Specify Data Sources dialog box.

## Linking Rapidly Changing Data

linkdata buffers updates to data and dispatches them to plots at roughly half-second intervals. This makes data linking not suitable for smoothly animating changes in data values unless they are updated in loops that are forced to execute two times per second or less.

One consequence of buffering link updates is that linkdata might not detect changes in data streams it monitors. If you are running a function that uses `assignin` or `evalin` to update workspace variables, linkdata can sometimes fail to process updates that change values but not the size and class of workspace variables. Such failures only happen when the function itself updates the plot.

## Linking Brushed Graphs

If you link data sources to graphs that have been brushed, their brushing marks can change or vanish. This is because the workspace variables in those graphs now dictate which, if any, observations are brushed, superseding any brushing annotations that were applied to their graphical data (YData, etc.). For more details, see “How Data Linking Affects Data Brushing” on page 1-595 in the brush reference page.

## Examples

### Example 1

Create two variables, graph them as areaseries, and link the plot to them:

```
x = 1:20;
y = rand(20,3);
area(x,y)
linkdata on
```

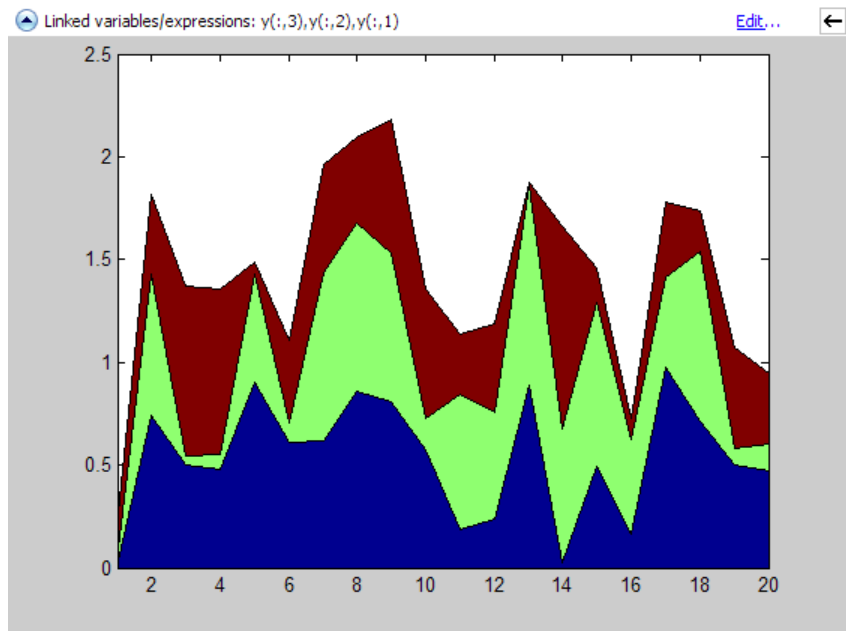

Change values for linked variable  $y$  in the workspace:

```
 $y(10,:) = 0;$
```

The area graph immediately updates.

# linkdata

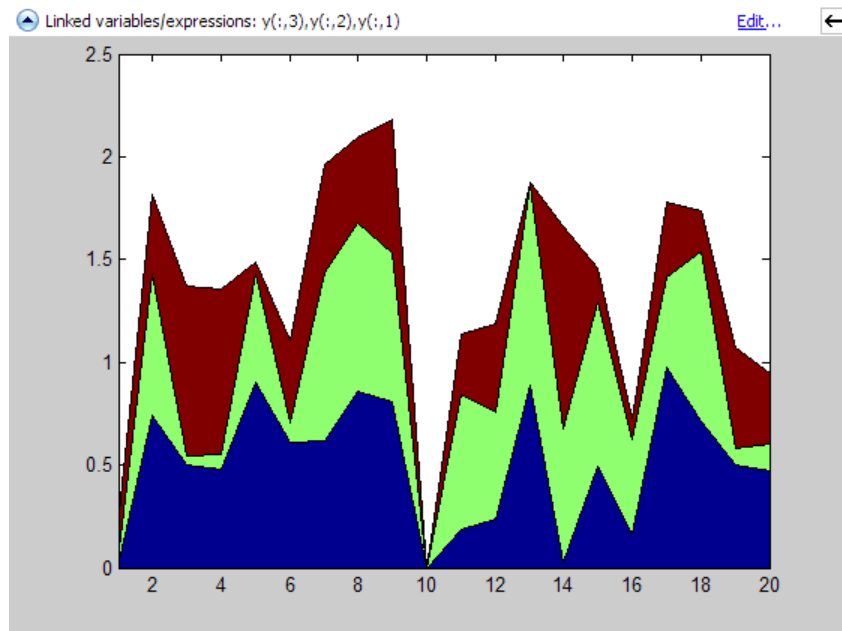

## Example 2

Delete a figure if it is not linked, based on a returned linkdata object:

```
fig = figure;
ld = linkdata(fig)

ld =
 graphics.linkdata

if strcmp(ld.Enable, 'off')
 delete(fig)
end
```

### Example 3

If a graphing function can display a complex variable, you can link such plots. To do so, you need to describe the data sources as expressions to separate the real and imaginary parts of the variable. For example,

```
x = eig(randn(20,20));
whos
 Name Size Bytes Class Attributes
 x 20x1 320 double complex
```

yields a complex vector. You can use `plot` to display the real portion as  $x$  and the imaginary portion as  $y$ , then link the graph to the variable:

```
plot(x)
linkdata
```

However, `linkdata` cannot unambiguously identify the graph's data sources, and you must tell it by typing `real(x)` and `imag(x)` into the Specify Data Source Properties dialog box that displays when you click **fix it** in the Linked Plot information bar.

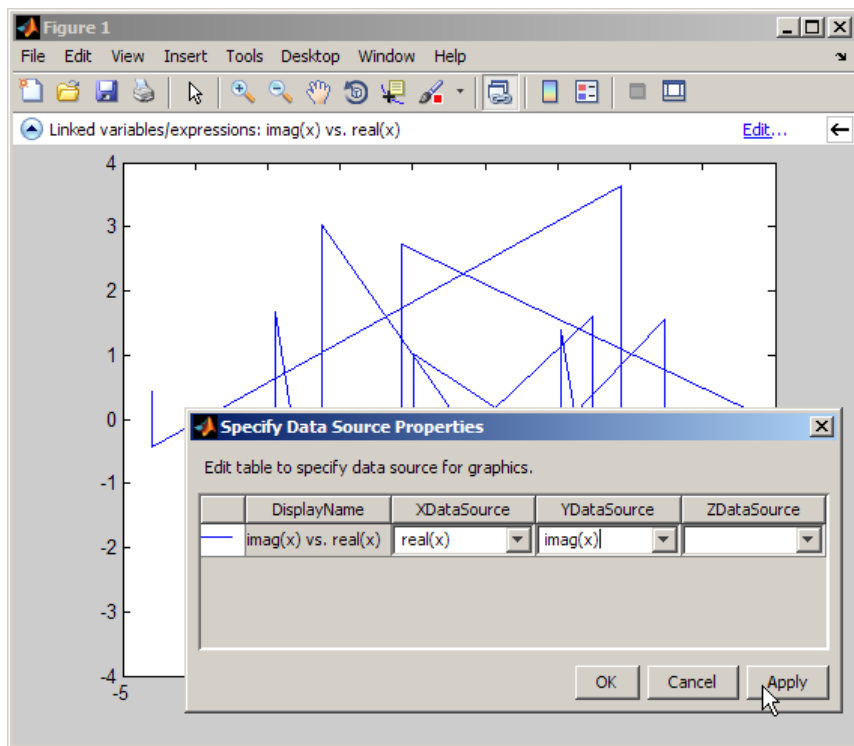

To avoid having to type the data source names in the dialog box, you can specify them when you plot:

```
plot(x, 'XDataSource', 'real(x)', 'YDataSource', 'imag(x)')
```

If you subsequently change values of  $x$  programmatically or manually, the plot updates accordingly.

---

**Note** Although you can use data brushing on linked plots of complex data, your brush marks only appear in the plot you are brushing, not in other plots or in the Variables editor. This is because function calls, such as `real(x)` and `imag(x)`, that you specify as data sources are not interpreted when brushing graphed data.

---

**See Also**

[brush](#) | [linkaxes](#) | [linkprop](#) | [refreshdata](#)

**How To**

- “Making Graphs Responsive with Data Linking”

# linkprop

---

<b>Purpose</b>	Keep same value for corresponding properties of graphics objects
<b>Syntax</b>	<pre>hlink = linkprop(obj_handles, 'PropertyName') hlink = linkprop(obj_handles, {'PropertyName1', 'PropertyName2', ...})</pre>
<b>Description</b>	Use linkprop to maintain the same values for the corresponding properties of different graphics objects.

---

**Note** Use linkprop only with Handle Graphics objects.

---

`hlink = linkprop(obj_handles, 'PropertyName')` maintains the same value for the property *PropertyName* on all objects whose handles appear in `obj_handles`. `linkprop` returns the link object in `hlink`. See “About Link Objects” on page 1-3823 for more information.

`hlink = linkprop(obj_handles, {'PropertyName1', 'PropertyName2', ...})` maintains the same respective values for all properties passed as a cell array on all objects whose handles appear in `obj_handles`.

MATLAB updates the linked properties of all linked objects immediately when `linkprop` is called. The first object in the list `obj_handles` determines the property values for the other objects.

A set of graphics objects can have only one link object connecting their properties at any given time. Calling `linkprop` creates a new link object. This new link object replaces any existing link object that is associated with the objects specified in `obj_handles`. However, you can manage which properties and which objects are linked by calling methods on that object:

- To add an object to the list of linked objects, use the `addtarget` method.
- To link new properties of currently-linked objects, use the `addprop` method.
- To stop linking an object, use the `removetarget` method.



## About Link Objects

- To stop properties from linking, use the `removeprop` method.

The link object that `linkprop` returns stores the mechanism that links the properties of different graphics objects. Therefore, the link object must exist within the context where you want property linking to occur (such as in the base workspace if users are to interact with the objects from the command line or figure tools).

The following list describes ways to maintain a reference to the link object.

- Return the link object as an output argument from a function and keep it in the base workspace while interacting with the linked objects.
- Make the `hlink` variable global.
- Store the `hlink` variable in an object's `UserData` property or in application data. See the “Examples” on page 1-3824 section for an example that uses application data.

## Updating a Link Object

If you want to change either the graphics objects or the properties that are linked, you need to use the link object methods designed for that purpose. These methods are functions that operate only on link objects. To use them, you must first create a link object using `linkprop`.

Method	Purpose
<code>addtarget</code>	Add specified graphics object to the link object's targets.
<code>removetarget</code>	Remove specified graphics object from the link object's targets.
<code>addprop</code>	Add specified property to the linked properties.
<code>removeprop</code>	Remove specified property from the linked properties.

## Method Syntax

```
ddtarget(hlink, obj_handles)
removetarget(hlink, obj_handles)
addprop(hlink, 'PropertyName')
removeprop(hlink, 'PropertyName')
```

## Method Arguments

- `hlink` — Link object returned by `linkprop`
- `obj_handles` — One or more graphic object handles
- `PropertyName` — Name of a property common to all target objects

## Examples

This example creates four isosurface graphs of fluid flow data, each displaying a different isovalue. The `CameraPosition` and `CameraUpVector` properties of each subplot axes are linked so that the user can rotate all subplots in unison.

After running the example, select **Rotate 3D** from the figure **Tools** menu and observe how all subplots rotate together.

---

**Note** You can run this example or open it in the MATLAB editor.

---

The property linking code is in step 3.

- 1 Define the data using `flow` and specify property values for the isosurface (which is a patch object).

```
[x,y,z,v] = flow;
isoval = [-3,-1,0,1];
props.FaceColor = [0,0,0.5];
props.EdgeColor = 'none';
props.AmbientStrength = 1;
props.FaceLighting = 'gouraud';
```

- 2 Create four subplot axes and add an isosurface graph to each one. Add a title and set viewing and lighting parameters. MATLAB functions used are `subplot`, `patch`, `isosurface`, `title`, and `num2str`. Also set the viewing and lighting parameters for each axes to be the same by calling `view`, `axis`, and `camlight`.

```
figure
% Preallocate h
h = zeros(1,4);
for k = 1:4
 h(k) = subplot(2,2,k);
 patch(isosurface(x,y,z,v,isoval(k)),props)
 title(h(k),['Isovalue = ',num2str(k)])
 % Set the view and add lighting
 view(h(k),3); axis(h(k),'tight','equal')
 camlight left; camlight right
 % Make axes invisible and title visible
 axis(h(k),'off')
 set(get(h(k),'title'),'Visible','on')
end
```

- 3 Link the `CameraPosition` and `CameraTarget` properties of all subplot axes. Since this code already is completed executing when you rotate the subplots, the link object is stored in the first subplot axes application data. See `setappdata` for more information on using application data.

```
if ishghandle(h)
 hlink = linkprop(h,{'CameraPosition','CameraUpVector'});
 key = 'graphics_linkprop';
 % Store link object on first subplot axes
 setappdata(h(1),key,hlink);
end
```

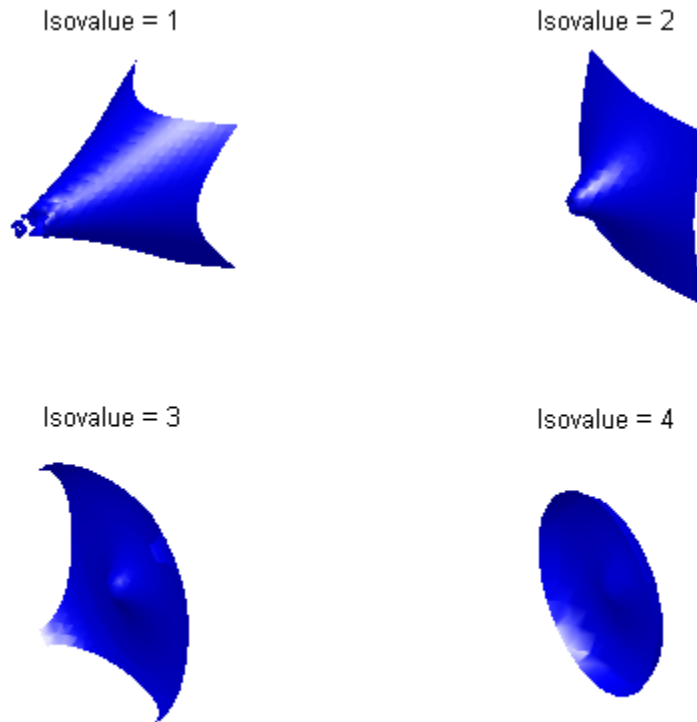

**4** Turn on the **Rotate 3D** tool. Click any object in the figure and rotate it. As you turn it, all three other subplots turn in the same manner.

```
rotate3d on
```

### Linking an Additional Property

Suppose you want to add the axes `PlotBoxAspectRatio` to the linked properties in the previous example. You can do this by modifying the link object that is stored in the first subplot axes' application data.

- 1 First click the first subplot axes to make it the current axes (since its handle was saved only within the creating function). Then get the link object's handle from application data (`getappdata`).

```
hlink = getappdata(gca, 'graphics_linkprop');
```

- 2 Use the `addprop` method to add a new property to the link object.

```
addprop(hlink, 'PlotBoxAspectRatio')
```

Since `hlink` is a reference to the link object (i.e., not a copy), `addprop` can change the object that is stored in application data.

## See Also

[getappdata](#) | [ishghandle](#) | [linkaxes](#) | [linkdata](#) | [setappdata](#)

# linsolve

---

**Purpose** Solve linear system of equations

**Syntax**  
`X = linsolve(A,B)`  
`X = linsolve(A,B,opts)`

**Description** `X = linsolve(A,B)` solves the linear system  $A*X = B$  using LU factorization with partial pivoting when A is square and QR factorization with column pivoting otherwise. The number of rows of A must equal the number of rows of B. If A is m-by-n and B is m-by-k, then X is n-by-k. `linsolve` returns a warning if A is square and ill conditioned or if it is not square and rank deficient.

`[X, R] = linsolve(A,B)` suppresses these warnings and returns R, which is the reciprocal of the condition number of A if A is square, or the rank of A if A is not square.

`X = linsolve(A,B,opts)` solves the linear system  $A*X = B$  or  $A'*X = B$ , using the solver that is most appropriate given the properties of the matrix A, which you specify in `opts`. For example, if A is upper triangular, you can set `opts.UT = true` to make `linsolve` use a solver designed for upper triangular matrices. If A has the properties in `opts`, `linsolve` is faster than `mldivide`, because `linsolve` does not perform any tests to verify that A has the specified properties.

---

**Notes** If A does not have the properties that you specify in `opts`, `linsolve` returns incorrect results and does not return an error message. If you are not sure whether A has the specified properties, use `mldivide` instead.

For small problems, there is no speed benefit in using `linsolve` on triangular matrices as opposed to using the `mldivide` function.

---

The `TRANSA` field of the `opts` structure specifies the form of the linear system you want to solve:

- If you set `opts.TRANS_A = false`, `linsolve(A,B,opts)` solves  $A \cdot X = B$ .
- If you set `opts.TRANS_A = true`, `linsolve(A,B,opts)` solves  $A' \cdot X = B$ .

The following table lists all the field of `opts` and their corresponding matrix properties. The values of the fields of `opts` must be logical and the default value for all fields is `false`.

Field Name	Matrix Property
LT	Lower triangular
UT	Upper triangular
UHESS	Upper Hessenberg
SYM	Real symmetric or complex Hermitian
POSDEF	Positive definite
RECT	General rectangular
TRANS_A	Conjugate transpose — specifies whether the function solves $A \cdot X = B$ or $A' \cdot X = B$

The following table lists all combinations of field values in `opts` that are valid for `linsolve`. A true/false entry indicates that `linsolve` accepts either true or false.

LT	UT	UHESS	SYM	POSDEF	RECT	TRANS_A
true	false	false	false	false	true/false	true/false
false	true	false	false	false	true/false	true/false
false	false	true	false	false	false	true/false
false	false	false	true	true/false	false	true/false
false	false	false	false	false	true/false	true/false

# linsolve

---

## Examples

The following code solves the system  $A'x = b$  for an upper triangular matrix  $A$  using both `mldivide` and `linsolve`.

```
A = triu(rand(5,3)); x = [1 1 1 0 0]'; b = A'*x;
y1 = (A')\b
opts.UT = true; opts.TRANS_A = true;
y2 = linsolve(A,b,opts)
```

y1 =

```
1.0000
1.0000
1.0000
0
0
```

y2 =

```
1.0000
1.0000
1.0000
0
0
```

---

**Note** If you are working with matrices having different properties, it is useful to create an options structure for each type of matrix, such as `opts_sym`. This way you do not need to change the fields whenever you solve a system with a different type of matrix  $A$ .

---

## See Also

`mldivide`



**Purpose** Generate linearly spaced vectors

**Syntax** `y = linspace(a,b)`  
`y = linspace(a,b,n)`

**Description** The `linspace` function generates linearly spaced vectors. It is similar to the colon operator `:`, but gives direct control over the number of points.

`y = linspace(a,b)` generates a row vector `y` of 100 points linearly spaced between and including `a` and `b`.

`y = linspace(a,b,n)` generates a row vector `y` of `n` points linearly spaced between and including `a` and `b`. For `n = 1`, `linspace` returns `b`.

**Examples** Create a vector of 100 linearly spaced numbers from 1 to 500:

```
A = linspace(1,500);
```

Create a vector of 12 linearly spaced numbers from 1 to 36:

```
A = linspace(1,36,12);
```

**See Also** `logspace` | `colon operator`

# RandStream.list

---

**Purpose** Random number generator algorithms

**Class** RandStream

**Syntax** RandStream.list

**Description** RandStream.list lists all the generator algorithms that may be used when creating a random number stream with RandStream or RandStream.create. The available generator algorithms and their properties are given in the following table.

<b>Keyword</b>	<b>Generator</b>	<b>Multiple Stream and Substream Support</b>	<b>Approximate Period In Full Precision</b>
mt19937ar	Mersenne twister (used by default stream at MATLAB startup)	No	$2^{19937} - 1$
mcg16807	Multiplicative congruential generator	No	$2^{31} - 2$
mlfg6331_64	Multiplicative lagged Fibonacci generator	Yes	$2^{124}$
mrg32k3a	Combined multiple recursive generator	Yes	$2^{127}$

<b>Keyword</b>	<b>Generator</b>	<b>Multiple Stream and Substream Support</b>	<b>Approximate Period In Full Precision</b>
shr3cong	Shift-register generator summed with linear congruential generator	No	$2^{64}$
swb2712	Modified subtract with borrow generator	No	$2^{1492}$

See “Choosing a Random Number Generator” for details about these generator algorithms. See <http://www.math.sci.hiroshima-u.ac.jp/~m-mat/MT/emt.html> for a full description of the Mersenne twister algorithm.

# listdlg

---

**Purpose** Create and open list-selection dialog box

**Syntax** [Selection,ok] = listdlg('ListString',S)

**Description** [Selection,ok] = listdlg('ListString',S) creates a modal dialog box that enables you to select one or more items from a list. Selection is a vector of indices of the selected strings (in single selection mode, its length is 1). Selection is [] when ok is 0. ok is 1 if you click the **OK** button, or 0 if you click the **Cancel** button or close the dialog box. Double-clicking on an item or pressing **Return** when multiple items are selected has the same effect as clicking the **OK** button. The dialog box has a **Select all** button (when in multiple selection mode) that enables you to select all list items.

Inputs are in parameter/value pairs:

Parameter	Description
'ListString'	Cell array of strings that specify the list box items.
'SelectionMode'	String indicating whether one or many items can be selected: 'single' or 'multiple' (the default).
'ListSize'	List box size in pixels, specified as a two-element vector [width height]. Default is [160 300].
'InitialValue'	Vector of indices of the list box items that are initially selected. Default is 1, the first item.
'Name'	String for the dialog box's title. Default is ''.
'PromptString'	String matrix or cell array of strings that appears as text above the list box. Default is {}.
'OKString'	String for the OK button. Default is 'OK'.
'CancelString'	String for the Cancel button. Default is 'Cancel'.
'uh'	Uicontrol button height, in pixels. Default is 18.

---

Parameter	Description
'fus'	Frame/uicontrol spacing, in pixels. Default is 8.
'ffs'	Frame/figure spacing, in pixels. Default is 8.

---

**Note** A modal dialog box prevents the user from interacting with other windows before responding. For more information, see `WindowState` in the MATLAB Figure Properties.

---

## Examples

This example displays a dialog box that enables the user to select a file from the current directory. The function returns a vector. Its first element is the index to the selected file; its second element is 0 if no selection is made, or 1 if a selection is made.

```
d = dir;
str = {d.name};
[s,v] = listdlg('PromptString','Select a file:',...
 'SelectionMode','single',...
 'ListString',str)
```

# listdlg

---

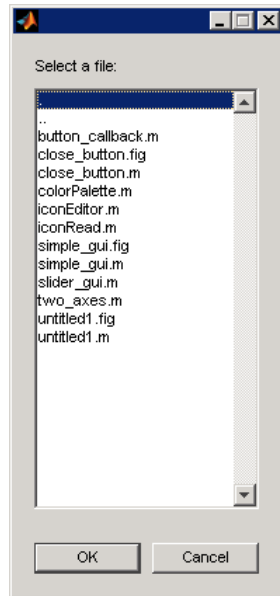

## See Also

`dialog` | `errordlg` | `helpdlg` | `inputdlg` | `msgbox` | `questdlg` | `warndlg` | `dir` | `figure` | `uiwait` | `uiresume`

**Purpose** List available system fonts

**Syntax**  
`c = listfonts`  
`c = listfonts(h)`

**Description** `c = listfonts` returns sorted list of available system fonts.  
`c = listfonts(h)` returns sorted list of available system fonts and includes the `FontName` property of the object with handle `h`.

**Tips** Calling `listfonts` returns a list of all fonts on your system, possibly including fonts that you cannot use with MATLAB. Consider using the `uisetfont` utility (a GUI) to preview fonts to use; it only displays fonts that MATLAB can render in figures and GUIs. Like `uisetfont`, the **Custom Fonts** pane of MATLAB Preferences also previews available fonts and only shows those that MATLAB can render.

## Examples **Example 1**

This example returns a list of available system fonts similar in format to the one shown.

```
list = listfonts

list =
 'Agency FB'
 'Algerian'
 'Arial'
 ...
 'ZapfChancery'
 'ZapfDingbats'
 'ZWAdobeF'
```

## **Example 2**

This example returns a list of available system fonts with the value of the `FontName` property, for the object with handle `h`, included and sorted in the list.

# listfonts

---

```
h = uicontrol('Style','text','String',...
 'My Font','FontName','MyFont');
list = listfonts(h)

list =
 'Agency FB'
 'Algerian'
 'Arial'
 ...
 'MyFont'
 ...
 'ZapfChancery'
 'ZapfDingbats'
 'ZWAdobeF'
```

## See Also

uisetfont



**Purpose** Load variables from file into workspace

**Syntax**

```
load(filename)
load(filename,variables)
load(filename,'-ascii')
load(filename,'-mat')
load(filename,'-mat',variables)

S = load(___)

load filename
```

**Description** `load(filename)` loads data from `filename`.

- If `filename` is a MAT-file, then `load(filename)` loads variables in the MAT-File into the MATLAB workspace.
- If `filename` is an ASCII file, then `load(filename)` creates a double-precision array containing data from the file.

`load(filename,variables)` loads the specified variables from the MAT-file, `filename`.

`load(filename,'-ascii')` treats `filename` as an ASCII file, regardless of the file extension.

`load(filename,'-mat')` treats `filename` as a MAT-file, regardless of the file extension.

`load(filename,'-mat',variables)` loads the specified variables from `filename`.

`S = load( ___ )` loads data into `S`, using any of the input arguments in the previous syntax group.

- If `filename` is a MAT-file, then `S` is a structure array.

# load

---

- If `filename` is an ASCII file, then `S` is a double-precision array containing data from the file.

`load filename` is the command form of the syntax. Command form requires fewer special characters. You do not need to type parentheses or enclose input strings in single quotes. Separate inputs with spaces instead of commas.

For example, to load a file named `durer.mat`, these statements are equivalent:

```
load durer.mat % command form
load('durer.mat') % function form
```

You can include any of the inputs described in previous syntaxes. For example, to load the variable named `X`:

```
load durer.mat X % command form
load('durer.mat','X') % function form
```

Do not use command form when any of the inputs, such as `filename`, are variables.

## Input Arguments

### **filename** - Name of file

`matlab.mat` (default) | string

Name of file, specified as a string. If you do not specify `filename`, the `load` function searches for a file named `matlab.mat`.

`filename` can include a file extension and a full or partial path. If `filename` has no extension (that is, no text after a period), `load` looks for a file named `filename.mat`. If `filename` has an extension other than `.mat`, the `load` function treats the file as ASCII data.

When using the command form of `load`, it is unnecessary to enclose input strings in single quotes. However, if `filename` contains a space, you must enclose the argument in single quotes. For example, `load 'filename withspace.mat'`.

ASCII files must contain a rectangular table of numbers, with an equal number of elements in each row. The file delimiter (the character between elements in each row) can be a blank, comma, semicolon, or tab character. The file can contain MATLAB comments (lines that begin with a percent sign, %).

**Example:** 'myFile.mat'

### Data Types

char

### variables - Names of variables to load

string

Names of variables to load, specified as one or more strings. When using the command form of `load`, you do not need to enclose input strings in single quotes. `variables` can be in one of the following forms.

Form of variables Input	Variables to Load
<i>var1, ..., varN</i>	Load the listed variables, specified as individual strings. Use the '*' wildcard to match patterns. For example, <code>load('filename.mat', 'A*')</code> or <code>load filename.mat A*</code> loads all variables in the file whose names start with A.
'-regexp', <i>expr1, ..., exprN</i>	Load only the variables or fields whose names match the regular expressions, specified as strings. For example, <code>load('filename.mat', '-regexp', '^Mon', '^Tue</code> or <code>load filename.mat -regexp ^Mon ^Tues</code> loads only the variables in the file whose names begin with Mon or Tues.

# load

---

## Data Types

char

## Output Arguments

### S - Loaded variables or data

structure array | m-by-n array

Loaded variables, returned as a structure array, if `filename` is a MAT-File.

Loaded data, returned as an m-by-n array of type `double`, if `filename` is an ASCII file. `m` is equal to the number of lines in the file, and `n` is equal to the number of values on a line.

## Examples

### Load All Variables from MAT-File

Load all variables from the example MAT-file, `gong.mat`. Check the contents of the workspace before and after the load operation.

```
disp('Contents of workspace before loading file:')
whos
```

```
disp('Contents of gong.mat:')
whos('-file','gong.mat')
```

```
load('gong.mat')
disp('Contents of workspace after loading file:')
whos
```

You also can use command syntax to load the variables. Clear the previously loaded variables and repeat the load operation.

```
clear y Fs
```

```
load gong.mat
```

## Load Specific Variable From MAT-File

Load only variable `y` from example file `handel.mat`. If the workspace already contains variable `y`, the load operation overwrites it with data from the file.

```
load('handel.mat','y')
```

You also can use command syntax to load the variable, `y`.

```
load handel.mat y
```

## Use Regular Expressions to Load Specific Variables

View the contents of the example file, `accidents.mat`.

```
whos -file accidents.mat
```

Name	Size	Bytes	Class	Attributes
<code>datasources</code>	3x1	2724	cell	
<code>hwycols</code>	1x1	8	double	
<code>hwydata</code>	51x17	6936	double	
<code>hwyheaders</code>	1x17	2758	cell	
<code>hwyidx</code>	51x1	408	double	
<code>hwyrows</code>	1x1	8	double	
<code>statelabel</code>	51x1	6596	cell	
<code>ushwydata</code>	1x17	136	double	
<code>uslabel</code>	1x1	138	cell	

Use function syntax to load all variables with names not beginning with `'hwy'`, from the file.

```
load('accidents.mat', '-regexp', '^(!hwy)...')
```

Alternatively, use command syntax to load the same variables.

```
load accidents.mat -regexp '^(!hwy)...'
```

## Load List of Variables into Structure Array

The file, `durer.mat`, contains variables `X`, `caption`, and `map`. Create a cell array of variable names to load.

```
filename = 'durer.mat';
myVars = {'X','caption'};
S = load(filename,myVars{:})
```

```
S =

 X: [648x509 double]
 caption: [2x28 char]
```

Only the variables `X` and `caption` are loaded into the structure array, `S`.

## Load ASCII File

Create an ASCII file from several 4-column matrices, and load the data back into a double-precision array.

```
a = magic(4);
b = ones(2, 4) * -5.7;
c = [8 6 4 2];
save -ascii mydata.dat a b c
clear a b c
```

```
load mydata.dat -ascii
```

`load` creates an array of type `double` named `mydata`.

View information about `mydata`.

```
whos mydata
```

Name	Size	Bytes	Class	Attributes
mydata	7x4	224	double	

**Algorithms**

If you do not specify an output for the `load` function, MATLAB creates a variable named after the loaded file (minus any file extension). For example, the command

```
load mydata.dat
```

reads data into a variable called `mydata`.

To create the variable name, `load` precedes any leading underscores or digits in `filename` with an `X` and replaces any other nonalphanumeric characters with underscores. For example, the command

```
load 10-May-data.dat
```

creates a variable called `X10_May_data`.

**See Also**

`clear` | `importdata` | `matfile` | `regexp` | `save` | `uiimport` | `whos`

**Concepts**

- “Supported File Formats for Import and Export”
- “Save, Load, and Delete Workspace Variables”
- “Ways to Import Text Files”
- “Loading Variables within a Function”
- “Import or Export a Sequence of Files”
- “Command vs. Function Syntax”

# load (COM)

---

**Purpose** Initialize control object from file

**Syntax** `h.load('filename')`  
`load(h, 'filename')`

**Description** `h.load('filename')` initializes the COM object associated with the interface represented by the MATLAB COM object `h` from file specified in the string `filename`. The file must have been created previously by serializing an instance of the same control.

`load(h, 'filename')` is an alternate syntax for the same operation.

---

**Note** The COM load function is only supported for controls at this time.

---

**Tips** COM functions are available on Microsoft Windows systems only.

**Examples** Create an `mwsamp` control and save its original state to the file `mwsample`:

```
f = figure('position', [100 200 200 200]);
h = actxcontrol('mwsamp.mwsampctrl1.2', [0 0 200 200], f);
h.save('mwsample')
```

Now, alter the figure by changing its label and the radius of the circle:

```
h.Label = 'Circle';
h.Radius = 50;
h.Redraw;
```

Using the `load` function, you can restore the control to its original state:

```
h.load('mwsample');
h.get
```

MATLAB displays the original values:

```
ans =
```



```
Label: 'Label'
Radius: 20
```

## See Also

save (COM) | actxcontrol | actxserver | release | delete (COM)

# load (serial)

---

**Purpose** Load serial port objects and variables into MATLAB workspace

**Syntax** `load filename`  
`load filename obj1 obj2...`

**Description** `load filename` returns all variables from the file specified by `filename` into the MATLAB workspace.

`load filename obj1 obj2...` returns the serial port objects specified by `obj1 obj2 ...` from the file `filename` into the MATLAB workspace.

`out = load('filename','obj1','obj2',...)` returns the specified serial port objects from the file `filename` as a structure to `out` instead of directly loading them into the workspace. The field names in `out` match the names of the loaded serial port objects.

**Tips** Values for read-only properties are restored to their default values upon loading. For example, the `Status` property is restored to `closed`. To determine if a property is read-only, examine its reference pages.

## Examples

---

**Note** This example is based on a Windows platform.

---

Suppose you create the serial port objects `s1` and `s2`, configure a few properties for `s1`, and connect both objects to their instruments:

```
s1 = serial('COM1');
s2 = serial('COM2');
set(s1,'Parity','mark','DataBits',7);
fopen(s1);
fopen(s2);
```

Save `s1` and `s2` to the file `MyObject.mat`, and then load the objects back into the workspace:

```
save MyObject s1 s2;
load MyObject s1;
```

```
load MyObject s2;

get(s1, {'Parity', 'DataBits'})

ans =
 'mark' [7]

get(s2, {'Parity', 'DataBits'})

ans =
 'none' [8]
```

### See Also

save | Status

# loadlibrary

---

**Purpose** Load shared library into MATLAB

**Syntax**

```
loadlibrary(libname,hfile)
loadlibrary(libname)
loadlibrary(libname,hfile,Name,Value)
```

```
loadlibrary(libname,@protofile)
```

```
[notfound,warnings] = loadlibrary(___)
```

**Description** `loadlibrary(libname,hfile)` loads functions from shared library, `libname`, defined in header file, `hfile`, into MATLAB.

`loadlibrary(libname)` loads the library if the name of the header file is the same as the name of the library file.

`loadlibrary(libname,hfile,Name,Value)` loads the library with one or more `Name,Value` arguments.

`loadlibrary(libname,@protofile)` uses a prototype file, `protofile`, in place of a header file.

`[notfound,warnings] = loadlibrary( ___ )` returns warning information, and can include any of the input arguments in previous syntaxes.

## Limitations

- You must have a supported C compiler and Perl must be available.
- Do not call `loadlibrary` if the library is already in memory. To test this condition, call `libisloaded`.
- `loadlibrary` does not support libraries generated by the MATLAB Compiler™ product.
- The MATLAB Shared Library interface does not support library functions with function pointer inputs.

## Input Arguments

### **libname - Name of shared library**

string

Name of shared library, specified as a string. The name is case-sensitive and must match the file on your system.

On Microsoft Windows systems, `libname` refers to the name of a shared library (.dll) file. On Linux systems, it refers to the name of a shared object (.so) file. On Apple Macintosh systems, it refers to a dynamic shared library (.dylib).

If you do not include a file extension with the `libname` argument, `loadlibrary` attempts to find the library with either the appropriate platform MEX-file extension or the appropriate platform library extension. For a list of MEX-file extensions, use `mexext`.

### **Data Types**

char

### **hfile - Name of C header file**

string

Name of C header file, specified as a string. The name is case-sensitive and must match the file on your system. If you do not include a file extension in the file name, `loadlibrary` uses `.h` for the extension.

### **Data Types**

char

### **protofile - Name of prototype file**

string

Name of prototype file, specified as a string. The name is case-sensitive and must match the file on your system. The string `@protofile` specifies a function handle to the prototype file. When using a prototype file, the only valid Name, Value pair argument is **alias**.

### **Data Types**

char

## **Name-Value Pair Arguments**

Specify optional comma-separated pairs of `Name`, `Value` arguments. `Name` is the argument name and `Value` is the corresponding value. `Name` must appear inside single quotes ( `' '` ). You can specify several name and value pair arguments in any order as `Name1, Value1, . . . , NameN, ValueN`.

### **Example:**

#### **'addheader' - Header file**

string

Header file, specified as the comma-separated pair consisting of `'addheader'` and a string. Specify the file name without a file extension.

Each file specified by `addheader` must have a corresponding `#include` statement in the base header file. To load only the functions defined in the header file that you want to use in MATLAB, use `addheader`.

MATLAB does not verify the existence of header files and ignores any that are not needed.

#### **'alias' - Alternative name for library**

string

Alternative name for library, specified as the comma-separated pair consisting of `'alias'` and a string. Associates the specified name with the library. All subsequent calls to MATLAB functions that reference this library must use this alias until the library is unloaded.

#### **'includepath' - More search path for subordinate header files**

string

more search path for subordinate header files—header files within header files, specified as the comma-separated pair consisting of `'includepath'` and a string.

#### **'mfilename' - Prototype file**

string

Prototype file, specified as the comma-separated pair consisting of 'mfilename' and a string. Generates a prototype file in the current folder. The prototype file name must be different from the library name. Use this file in place of a header file when loading the library.

### 'thunkfilename' - Thunk file

string

Thunk file, specified as the comma-separated pair consisting of 'thunkfilename' and a string. Overrides the default thunk file name.

## Output Arguments

### notfound - Names of functions

cell array

Names of functions found in header files but missing from the library, returned as cell array.

### Data Types

cell

### warnings - Warnings

character array

Warnings produced while processing the header file, returned as character array.

## Examples

### Load Functions in shrlibsampl Library

Add path to examples folder.

```
addpath(fullfile(matlabroot,'extern','examples','shrlib'))
```

Load shrlibsampl.

```
loadlibrary('shrlibsampl')
```

Cleanup.

```
unloadlibrary shrlibsampl
```

## Load Library Using Header File

The header file for the libmx library is matrix.h.

```
hfile = fullfile(matlabroot,'extern','include','matrix.h');
loadlibrary('libmx',hfile)
```

Cleanup.

```
unloadlibrary libmx
```

## Load Library Using Multiple Header Files

Suppose that you have a library, mylib, with the header file, mylib.h. The header file contains the statement, #include header2.h. To use functions defined in header2.h, call loadlibrary with the addheader option.

```
loadlibrary('mylib','mylib.h','addheader','header2')
```

## Load Library Using an Alias Name

Create an alias, lib, for library, shrlibsampl.

```
loadlibrary('shrlibsampl','alias','lib')
```

Use the alias name, lib, to call a function in the library.

```
str = 'This was a Mixed Case string';
calllib('lib','stringToUpper',str)
```

```
ans =
 THIS WAS A MIXED CASE STRING
```

Cleanup.

```
unloadlibrary lib
```



## Search Alternative Paths for Header Files

Add path to folder containing `shrlibsample` and its header file, `shrlibsample.h`.

```
addpath(fullfile(matlabroot,'extern','examples','shrlib'))
```

The `shrlibsample.h` header file includes the header file, `shrhelp.h`. If `shrhelp.h` is in a different folder, for example, `c:\work`, use the `'includepath'` option to tell MATLAB where to find the file.

```
loadlibrary('shrlibsample','shrlibsample.h','includepath','c:\work')
```

Cleanup.

```
unloadlibrary shrlibsample
```

## Tips

- If you have more than one library file of the same name, load the first using the library file name. Then load the additional libraries using the **alias** option.

## Definitions

### Prototype File

A prototype file is a file of MATLAB commands which you can modify and use in place of a header file.

### Thunk File

A thunk file is a compatibility layer to a 64-bit library generated by MATLAB. The name of the thunk file is `BASENAME_thunk_COMPUTER.c` where *BASENAME* is either the name of the shared library or, if specified, the `mfilename` prototype name. *COMPUTER* is the string returned by the `computer` function.

MATLAB compiles this file and creates the file `BASENAME_thunk_COMPUTER.LIBEXT`, where *LIBEXT* is the platform-dependent default shared library extension, for example, `dll` on Windows.

# loadlibrary

---

## See Also

[mex](#) | [unloadlibrary](#) | [libisloaded](#) | [libfunctions](#) | [computer](#)  
| [calllib](#) | [mexext](#)

## Related Examples

- “Create Alias Function Name Using Prototype File”

## External Web Sites

- Supported and Compatible Compilers

<b>Purpose</b>	Modify load process for object
<b>Syntax</b>	<code>b = loadobj (a)</code>
<b>Description</b>	<p><code>b = loadobj (a)</code> is called by the <code>load</code> function if the class of <code>a</code> defines a <code>loadobj</code> method. <code>load</code> returns <code>b</code> as the value loaded from a MAT-file.</p> <p>Define a <code>loadobj</code> method when objects of the class require special processing when loaded from MAT-files. If you define a <code>saveobj</code> method, then define a <code>loadobj</code> method to restore the object to the desired state. Define <code>loadobj</code> as a static method so it can accept as an argument whatever object or structure that you saved in the MAT-file. See “Implement <code>loadobj</code> as a Static Method”.</p> <p>When loading a subclass object, <code>load</code> calls only the subclass <code>loadobj</code> method. If a superclass defines a <code>loadobj</code> method, the subclass inherits this method. However, it is possible that the inherited method does not perform the necessary operations to load the subclass object. Consider overriding superclass <code>loadobj</code> methods.</p> <p>If any superclass in a class hierarchy defines a <code>loadobj</code> method, then the subclass <code>loadobj</code> method must ensure that the subclass and superclass objects load properly. Ensure proper loading by calling the superclass <code>loadobj</code> (or other methods) from the subclass <code>loadobj</code> method. See “Saving and Loading Objects from Class Hierarchies”.</p>
<b>Input Arguments</b>	<p><b>a</b></p> <p>The input argument, <code>a</code>, can be:</p> <ul style="list-style-type: none"><li>• The object as loaded from the MAT-file.</li><li>• A structure created by <code>load</code> (if <code>load</code> cannot resolve the object).</li><li>• A struct returned by the <code>saveobj</code> method.</li></ul>
<b>See Also</b>	<code>load</code>   <code>save</code>   <code>saveobj</code>
<b>Tutorials</b>	<ul style="list-style-type: none"><li>• “Control Save and Load”</li></ul>

# localfunctions

---

**Purpose** Function handles to all local functions in MATLAB file

**Syntax** `fcns = localfunctions`

**Description** `fcns = localfunctions` returns a cell array of function handles, `fcns`, to all local functions in the current file.

You cannot define local functions in the context of the command line, scripts, or anonymous functions, so when you call `localfunctions` from these contexts, you get an empty cell array. Within the cell array, `localfunctions` returns the function handles in an undefined order.

## **Examples** **Display Handles to Local Functions in File**

Create a new file, `fileWithLocalFunctions.m`, in your MATLAB path. In the main function, call and display the results of `localfunctions`. In the same file, create two local functions.

```
function fileWithLocalFunctions
```

```
 fcns = localfunctions;
 display(fcns);
```

```
function alocalfunction
```

```
function anotherlocalfunction
```

From the command line, call your function.

```
fileWithLocalFunctions
```

```
fcns =
```

```
 @alocalfunction
 @anotherlocalfunction
```

**See Also** `functiontests`

## Concepts

- “Local Functions”

# log

---

**Purpose** Natural logarithm

**Syntax**  $Y = \log(X)$

**Description**  $Y = \log(X)$  returns the natural logarithm of each element in array  $X$ . The function accepts both real and complex inputs. For real values of  $X$  in the interval  $(0, \text{Inf})$ ,  $\log$  returns real values in the interval  $(-\text{Inf}, \text{Inf})$ . For complex and negative real values of  $X$ ,  $\log$  returns complex values.

**Input Arguments**

**X - Input array**

scalar | vector | matrix | multidimensional array

Input array, specified as a scalar, vector, matrix, or multidimensional array.

**Data Types**

single | double

**Complex Number Support:** Yes

**Examples**

**Calculate Scalar Natural Logarithm Values**

Examine several common values of the natural logarithm function.

Calculate the natural logarithm of 1.

```
log(1)
```

```
ans =
```

```
0
```

The result is 0, which is the x-intercept of the function.

Calculate the natural logarithm of Euler's number,  $e$ .

```
log(exp(1))
```

```
ans =
```

---

1

The result is 1 because  $\log$  is the inverse of  $\exp$ .

Calculate the natural logarithm of -1.

$\log(-1)$

ans =

0.0000 + 3.1416i

The result is equal to  $i\pi$ .

Calculate the natural logarithm of 0.

$\log(0)$

ans =

-Inf

The result is -Inf because  $\log$  is a monotonically increasing function over the real domain  $(0, \infty)$ .

### **Plot Real-Valued Natural Logarithm**

Define the domain.

$X = (0.25:0.25:5)'$ ;

Calculate the natural logarithm of the vector, X.

$Y = \log(X)$

Y =

-1.3863

# log

---

```
-0.6931
-0.2877
 0
 0.2231
 0.4055
 0.5596
 0.6931
 0.8109
 0.9163
 1.0116
 1.0986
 1.1787
 1.2528
 1.3218
 1.3863
 1.4469
 1.5041
 1.5581
 1.6094
```

The result is a vector of natural logarithm values.

Plot the function values.

```
plot(X,Y,'LineWidth',1.5);
grid on;
xlabel('X'); ylabel('Y');
title('Real-Valued Natural Logarithm');
```



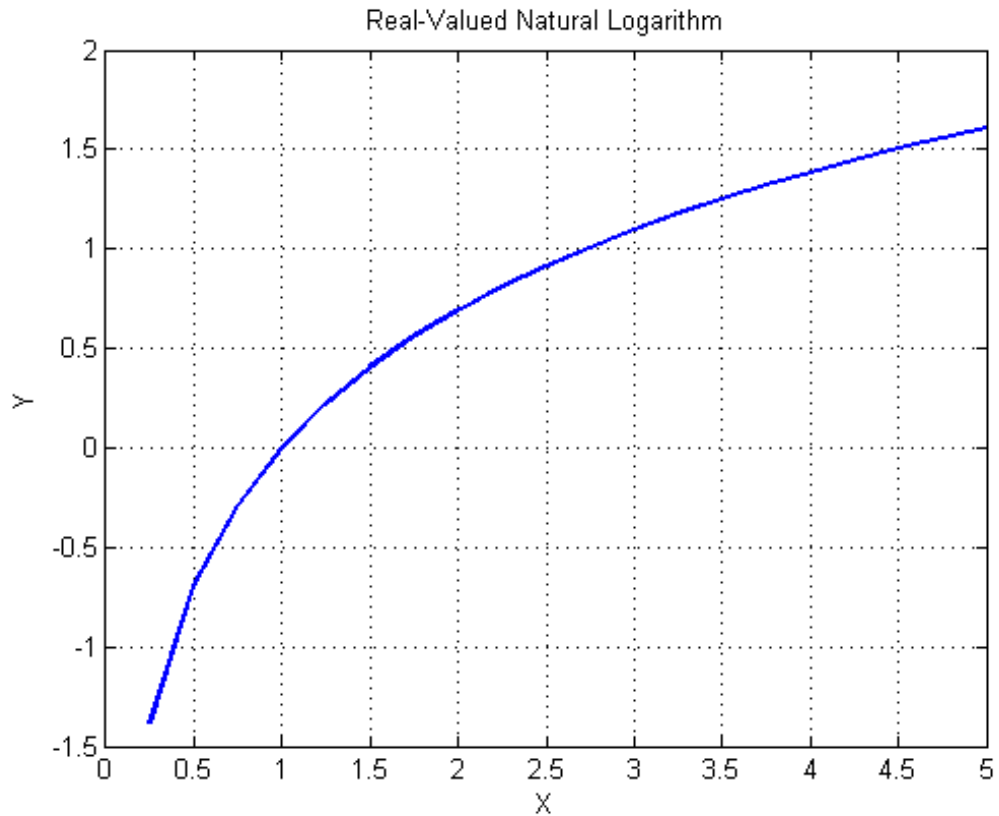

The real-valued natural logarithm maps values in the domain  $(0, \infty)$  to the range  $(-\infty, \infty)$ .

### Plot Branches of Complex Logarithm

Define a grid of values for the (X,Y) domain.

```
[X,Y] = meshgrid(-4:0.25:4, -4:0.25:4);
```

Calculate the complex logarithm on the grid.

```
Z = log(X+1i*Y);
```

Make a surface plot of the imaginary portion of the function.

```
surf(X,Y,imag(Z))
grid on; hold on;
title('Principal Branch of Im[$\log(X+iY)$ '],'Interpreter','latex')
xlabel('X'); ylabel('Y'); zlabel('Z');
view(44,42)
```

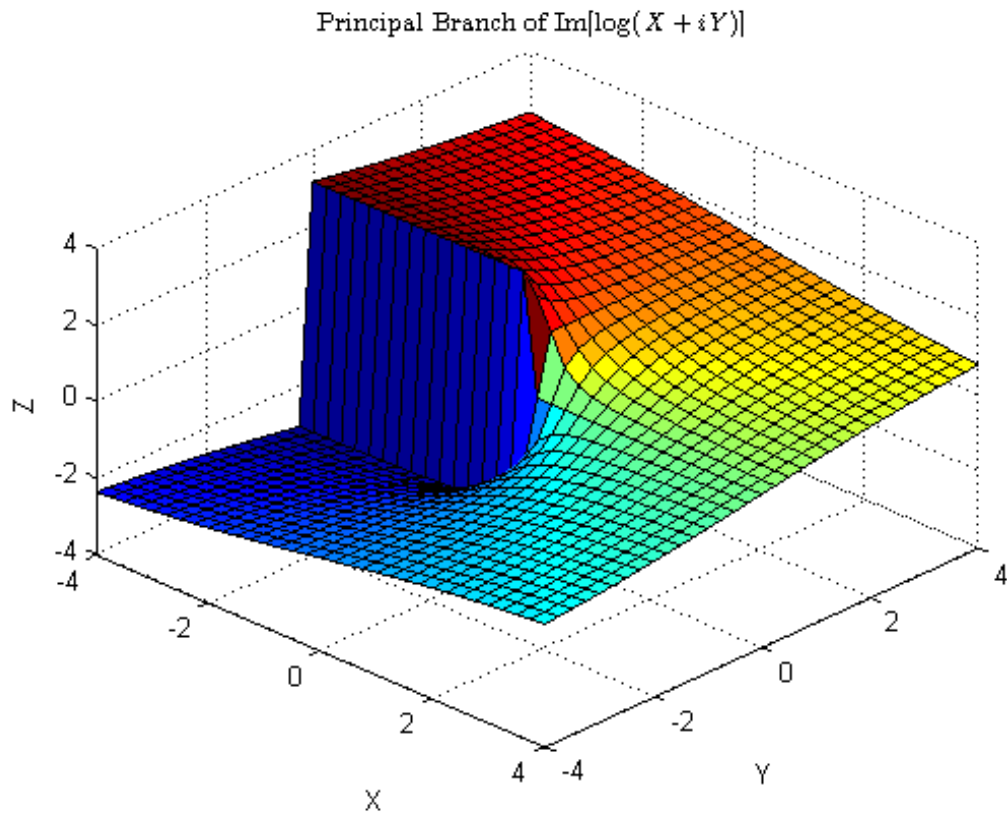

On the complex plane, the natural logarithm is a multivalued function that winds around the origin.

To obtain a different branch of the function, add  $2\pi i$  to the Z values.

```
z2 = Z + 2*pi*1i;
surf(X,Y,imag(z2))
title('Two Branches of the Complex Logarithm')
view(45,22)
```

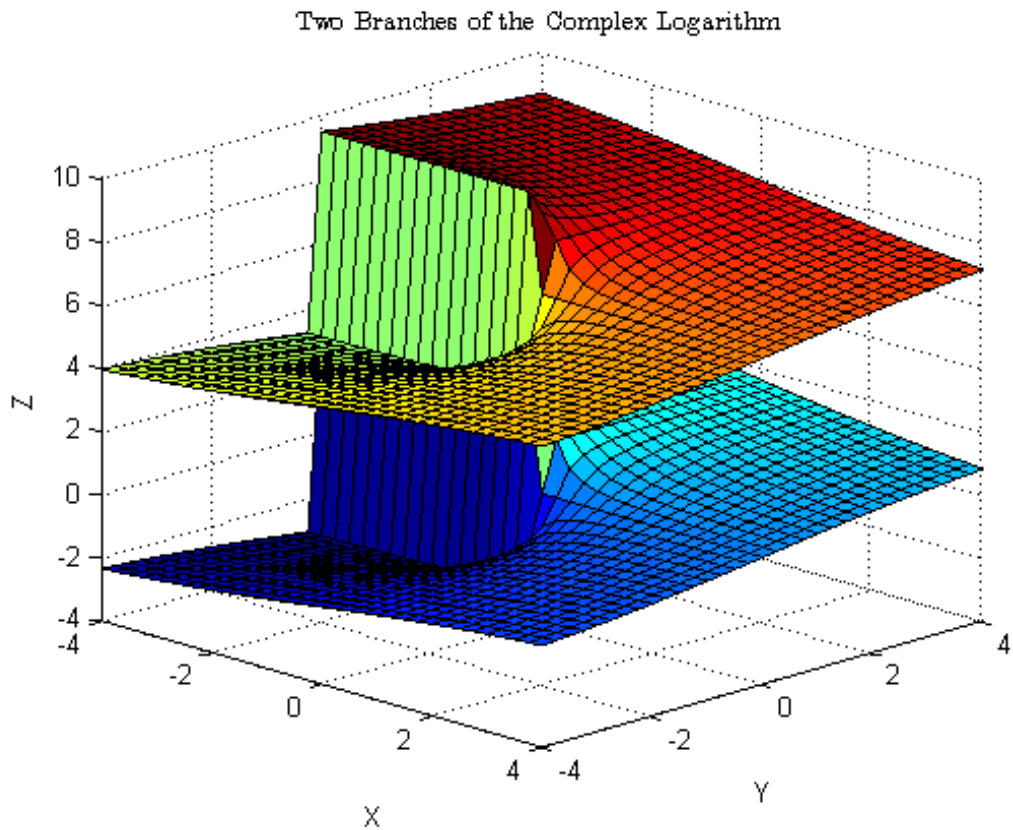

# log

---

In this plot, the branches are stacked on top of each other and meet along the negative real axis.

## Algorithms

For complex or negative inputs, `log` computes the complex logarithm  $\log(\text{abs}(z)) + 1i*\text{atan2}(y,x)$ .

## See Also

`log1p` | `log2` | `log10` | `exp` | `logm` | `reallog` | `loglog` | `semilogx` | `semilogy`

**Purpose** Common (base 10) logarithm

**Syntax**  $Y = \log_{10}(X)$

**Description** The `log10` function operates element-by-element on arrays. Its domain includes complex numbers, which may lead to unexpected results if used unintentionally.

$Y = \log_{10}(X)$  returns the base 10 logarithm of the elements of  $X$ .

**Examples** `log10(realmax)` is 308.2547

and

`log10(eps)` is -15.6536

**See Also** `exp` | `log` | `log2` | `logm`

# log1p

---

**Purpose** Compute  $\log(1+x)$  accurately for small values of  $x$

**Syntax**  $y = \log1p(x)$

**Description**  $y = \log1p(x)$  computes  $\log(1+x)$ , compensating for the roundoff in  $1+x$ .  $\log1p(x)$  is more accurate than  $\log(1+x)$  for small values of  $x$ . For small  $x$ ,  $\log1p(x)$  is approximately  $x$ , whereas  $\log(1+x)$  can be zero.

**See Also** `log` | `expm1`

**Purpose** Base 2 logarithm and dissect floating-point numbers into exponent and mantissa

**Syntax**  $Y = \log_2(X)$   
 $[F, E] = \log_2(X)$

**Description**  $Y = \log_2(X)$  computes the base 2 logarithm of the elements of  $X$ .  
 $[F, E] = \log_2(X)$  returns arrays  $F$  and  $E$ . Argument  $F$  is an array of real values, usually in the range  $0.5 \leq \text{abs}(F) < 1$ . For real  $X$ ,  $F$  satisfies the equation:  $X = F \cdot 2.^E$ . Argument  $E$  is an array of integers that, for real  $X$ , satisfy the equation:  $X = F \cdot 2.^E$ .

**Tips** This function corresponds to the ANSI C function `frexp()` and the IEEE floating-point standard function `logb()`. Any zeros in  $X$  produce  $F = 0$  and  $E = 0$ .

**Examples** For IEEE arithmetic, the statement  $[F, E] = \log_2(X)$  yields the values:

<b>X</b>	<b>F</b>	<b>E</b>
1	1/2	1
pi	pi/4	2
-3	-3/4	2
eps	1/2	-51
realmax	1 - eps/2	1024
realmin	1/2	-1021

**See Also** `log` | `pow2`

# logical

---

**Purpose** Convert numeric values to logicals

**Syntax** `L = logical(A)`

**Description** `L = logical(A)` converts numeric input `A` into an array of logical values. Any nonzero element of input `A` is converted to logical 1 (true) and zeros are converted to logical 0 (false). Complex values and NaNs cannot be converted to logical values and result in a conversion error.

**Input Arguments**

**A - Numeric input**

scalar | vector | matrix | multidimensional array

Numeric input, specified as a scalar, vector, matrix, or multidimensional array.

**Data Types**

single | double | int8 | int16 | int32 | int64 | uint8 | uint16 | uint32 | uint64 | logical

**Examples**

**Pick Odd Elements from Numeric Matrix**

Pick out the odd-numbered elements of a numeric matrix.

Create a numeric matrix.

```
A = [1 -3 2;5 4 7;-8 1 3];
```

Find the modulus, `mod(A,2)`, and convert it to a logical array for indexing.

```
L = logical(mod(A,2))
```

```
L =
```

```
 1 1 0
 1 0 1
 0 1 1
```

The array has logical 1 (true) values where `A` is odd.



Use L as a logical index to pick out the odd elements of A.

```
A(L)
```

```
ans =
```

```
1
5
-3
1
7
3
```

The result is a vector containing all odd elements of A.

Use the logical NOT operator, ~, on L to find the even elements of A.

```
A(~L)
```

```
ans =
```

```
-8
4
2
```

## Tips

- Most arithmetic operations involving logical arrays return double values. For example, adding zero to a logical array returns a double array.
- Logical arrays also are created by the relational operators (==,<,>,<=,>=, etc.) and functions like any, all, isnan, isinf, and isfinite.

## See Also

```
islogical | false | true
```

## Concepts

- “Using Logicals in Array Indexing”
- “Determine if Arrays Are Logical”

# loglog

---

## Purpose

Log-log scale plot

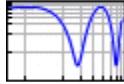

## Syntax

```
loglog(Y)
loglog(X1,Y1,...)
loglog(X1,Y1,LineStyle,...)
loglog(...,'PropertyName',PropertyValue,...)
h = loglog(...)
```

## Description

`loglog(Y)` plots the columns of `Y` versus their index if `Y` contains real numbers. If `Y` contains complex numbers, `loglog(Y)` and `loglog(real(Y),imag(Y))` are equivalent. `loglog` ignores the imaginary component in all other uses of this function.

`loglog(X1,Y1,...)` plots all  $Y_n$  versus  $X_n$  pairs. If only one of  $X_n$  or  $Y_n$  is a matrix, `loglog` plots the vector argument versus the rows or columns of the matrix, along the dimension of the matrix whose length matches the length of the vector. If the matrix is square, its columns plot against the vector if their lengths match.

`loglog(X1,Y1,LineStyle,...)` plots all lines defined by the  $X_n, Y_n, LineSpec$  triples, where `LineStyle` determines line type, marker symbol, and color of the plotted lines. You can mix  $X_n, Y_n, LineSpec$  triples with  $X_n, Y_n$  pairs, for example,

```
loglog(X1,Y1,X2,Y2,LineStyle,X3,Y3)
```

`loglog(...,'PropertyName',PropertyValue,...)` sets property values for all lineseries properties graphics objects created by `loglog`.

`h = loglog(...)` returns a column vector of lineseries handles, one handle per line.

If you do not specify a color when plotting more than one line, `loglog` automatically cycles through the colors and line styles in the order specified by the current axes.

If you attempt to add a `loglog`, `semilogx`, or `semilogy` plot to a linear axis mode graph with `hold on`, the axis mode remains as it is and the new data plots as linear.

### Renderer Support

The OpenGL renderer does not support logarithmic-scale axes. MATLAB automatically selects a different renderer when using logarithmic scaling. If you set the figure `Renderer` property to `opengl`, axis scales become linear. See the figure `Renderer` property for more information on renderers.

## Examples

### Logarithmic Scale for Both Axes

Create a plot using a logarithmic scale for both the x-axis and the y-axis. Set the `LineStyle` string so that `loglog` plots using a line with square markers. Display the grid.

```
x = logspace(-1,2);
y = exp(x);

figure
loglog(x,y,'-s');
grid on
```

# loglog

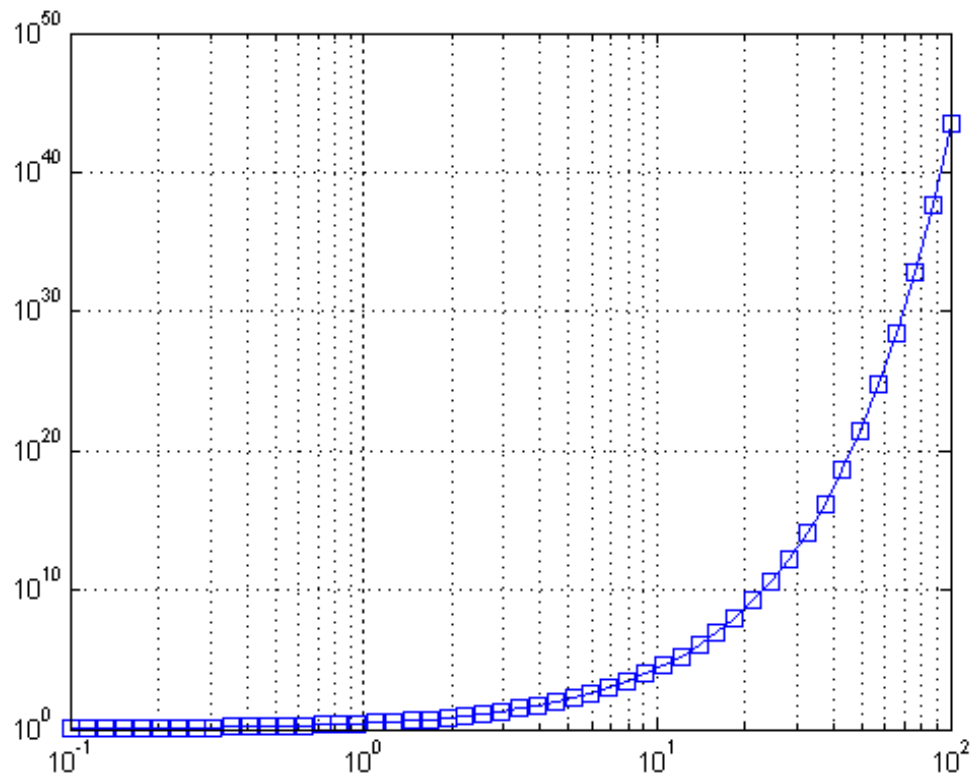

## See Also

[LineSpec](#) | [plot](#) | [semilogx](#) | [semilogy](#)

**Purpose** Matrix logarithm

**Syntax**  $L = \text{logm}(A)$   
 $[L, \text{exitflag}] = \text{logm}(A)$

**Description**  $L = \text{logm}(A)$  is the principal matrix logarithm of  $A$ , the inverse of  $\text{expm}(A)$ .  $L$  is the unique logarithm for which every eigenvalue has imaginary part lying strictly between  $-\pi$  and  $\pi$ . If  $A$  is singular or has any eigenvalues on the negative real axis, the principal logarithm is undefined. In this case, `logm` computes a nonprincipal logarithm and returns a warning message.

$[L, \text{exitflag}] = \text{logm}(A)$  returns a scalar `exitflag` that describes the exit condition of `logm`:

- If `exitflag` = 0, the algorithm was successfully completed.
- If `exitflag` = 1, too many matrix square roots had to be computed. However, the computed value of  $L$  might still be accurate.

The input  $A$  can have class `double` or `single`.

**Tips** If  $A$  is real symmetric or complex Hermitian, then so is  $\text{logm}(A)$ .

Some matrices, like  $A = \begin{bmatrix} 0 & 1 \\ 0 & 0 \end{bmatrix}$ , do not have any logarithms, real or complex, so `logm` cannot be expected to produce one.

**Limitations** For most matrices:

$$\text{logm}(\text{expm}(A)) = A = \text{expm}(\text{logm}(A))$$

These identities may fail for some  $A$ . For example, if the computed eigenvalues of  $A$  include an exact zero, then  $\text{logm}(A)$  generates infinity. Or, if the elements of  $A$  are too large,  $\text{expm}(A)$  may overflow.

**Examples** Suppose  $A$  is the 3-by-3 matrix

$$\begin{bmatrix} 1 & 1 & 0 \\ 0 & 0 & 2 \end{bmatrix}$$

0      0      -1

and  $Y = \text{expm}(A)$  is

Y =  
2.7183      1.7183      1.0862  
0      1.0000      1.2642  
0      0      0.3679

Then  $A = \text{logm}(Y)$  produces the original matrix A.

Y =  
1.0000      1.0000      0.0000  
0      0      2.0000  
0      0      -1.0000

But  $\text{log}(A)$  involves taking the logarithm of zero, and so produces

ans =  
0.0000                      0                      -35.5119  
-Inf                      -Inf                      0.6931  
-Inf                      -Inf                      0.0000 + 3.1416i

## Algorithms

The algorithm `logm` uses is described in [1].

## References

- [1] Davies, P. I. and N. J. Higham, "A Schur-Parlett algorithm for computing matrix functions," *SIAM J. Matrix Anal. Appl.*, Vol. 25, Number 2, pp. 464-485, 2003.
- [2] Cheng, S. H., N. J. Higham, C. S. Kenney, and A. J. Laub, "Approximating the logarithm of a matrix to specified accuracy," *SIAM J. Matrix Anal. Appl.*, Vol. 22, Number 4, pp. 1112-1125, 2001.
- [3] Higham, N. J., "Evaluating Pade approximants of the matrix logarithm," *SIAM J. Matrix Anal. Appl.*, Vol. 22, Number 4, pp. 1126-1135, 2001.

[4] Golub, G. H. and C. F. Van Loan, *Matrix Computation*, Johns Hopkins University Press, 1983, p. 384.

[5] Moler, C. B. and C. F. Van Loan, "Nineteen Dubious Ways to Compute the Exponential of a Matrix," *SIAM Review* 20, 1978, pp. 801-836.

**See Also**

`expm` | `funm` | `sqrtm`

# logspace

---

**Purpose** Generate logarithmically spaced vectors

**Syntax**  
`y = logspace(a,b)`  
`y = logspace(a,b,n)`  
`y = logspace(a,pi)`

**Description** The `logspace` function generates logarithmically spaced vectors. Especially useful for creating frequency vectors, it is a logarithmic equivalent of `linspace` and the “:” or colon operator.

`y = logspace(a,b)` generates a row vector `y` of 50 logarithmically spaced points between decades  $10^a$  and  $10^b$ .

`y = logspace(a,b,n)` generates `n` points between decades  $10^a$  and  $10^b$ .

`y = logspace(a,pi)` generates the points between  $10^a$  and  $\pi$ , which is useful for digital signal processing where frequencies over this interval go around the unit circle.

**Tips** All the arguments to `logspace` must be scalars.

**See Also** `linspace` | colon operator



---

<b>Purpose</b>	Search for keyword in all help entries
<b>Alternatives</b>	As an alternative to the <code>lookfor</code> function, use the Function Browser.
<b>Syntax</b>	<code>lookfor topic</code> <code>lookfor topic -all</code>
<b>Description</b>	<p><code>lookfor topic</code> searches for the string <code>topic</code> in the first comment line (the H1 line) of the help text in all MATLAB program files found on the search path. For all files in which a match occurs, <code>lookfor</code> displays the H1 line.</p> <p><code>lookfor topic -all</code> searches the entire first comment block of a MATLAB program file looking for <code>topic</code>.</p>
<b>Examples</b>	<p>For example:</p> <pre>lookfor inverse</pre> <p>finds at least a dozen matches, including H1 lines containing "inverse hyperbolic cosine," "two-dimensional inverse FFT," and "pseudoinverse." Contrast this with</p> <pre>which inverse</pre> <p>or</p> <pre>what inverse</pre> <p>These functions run more quickly, but probably fail to find anything because MATLAB does not have a function <code>inverse</code>.</p> <p>In summary, <code>what</code> lists the functions in a given folder, <code>which</code> finds the folder containing a given function or file, and <code>lookfor</code> finds all functions in all folders that might have something to do with a given keyword.</p> <p>Even more extensive than the <code>lookfor</code> function are the find features in the Current Folder browser. For example, you can look for all occurrences of a specified word in all the MATLAB program files in</p>

# lookfor

---

the current folder and its subfolders. For more information, see “Find Files and Folders”.

## See Also

`dir` | `doc` | `filebrowser` | `strfind` | `help` | `regexp` | `what` | `which` | `who`

## How To

- “Find Functions to Use”
- “Search Syntax and Tips”

**Purpose** Convert string to lowercase

**Syntax**  
`t = lower('str')`  
`B = lower(A)`

**Description** `t = lower('str')` returns the string formed by converting any uppercase characters in `str` to the corresponding lowercase characters and leaving all other characters unchanged.

`B = lower(A)` when `A` is a cell array of strings, returns a cell array the same size as `A` containing the result of applying `lower` to each string within `A`.

**Examples** `lower('MathWorks')` is `mathworks`.

**Tips** Character sets supported:

- PC: Latin-1 for the Microsoft Windows operating system
- Other: ISO Latin-1 (ISO 8859-1)

**See Also** `upper`

# ls

---

**Purpose** List folder contents

**Syntax** `ls`  
`ls name`  
`list = ls(name)`

**Description** `ls` lists the contents of the current folder.

`ls name` lists the files and folders in the current folder that match the specified name. You can use wildcards.

`list = ls(name)` returns the files and folders in the current folder that match the specified **name** to **list**.

**Tips**

- On UNIX platforms, you can add any flags to `ls` that the operating system supports.

**Input Arguments**

**name**  
A string value specifying a file or folder name.

**Output Arguments**

**list**

- On UNIX platforms, **list** is a character row vector of names separated by tab and space characters.
- On Microsoft Windows platforms, **list** is an m-by-n character array of names—**m** is the number of names and **n** is the number of characters in the longest name. MATLAB pads names shorter than **n** characters with space characters.

**Examples** List all the files and folders in the current folder:

```
ls
```

---

List all the files and folders in the current folder that begin with the letter `h`:

```
ls h*
```

---

Return the list of all the files and folders in the current folder to `mylist`:

```
mylist = ls;
```

**Alternatives**

- View files and folders in the Current Folder browser.  
Open the Current Folder browser by issuing the `filebrowser` command.

**See Also**

```
dir | pwd
```

**Purpose** Least-squares solution in presence of known covariance

**Syntax**

```
x = lscov(A,b)
x = lscov(A,b,w)
x = lscov(A,b,V)
x = lscov(A,b,V,alg)
[x,stdx] = lscov(...)
[x,stdx,mse] = lscov(...)
[x,stdx,mse,S] = lscov(...)
```

**Description** `x = lscov(A,b)` returns the ordinary least squares solution to the linear system of equations  $A^*x = b$ , i.e.,  $x$  is the  $n$ -by-1 vector that minimizes the sum of squared errors  $(b - A^*x)'*(b - A^*x)$ , where  $A$  is  $m$ -by- $n$ , and  $b$  is  $m$ -by-1.  $b$  can also be an  $m$ -by- $k$  matrix, and `lscov` returns one solution for each column of  $b$ . When  $\text{rank}(A) < n$ , `lscov` sets the maximum possible number of elements of  $x$  to zero to obtain a "basic solution".

`x = lscov(A,b,w)`, where  $w$  is a vector length  $m$  of real positive weights, returns the weighted least squares solution to the linear system  $A^*x = b$ , that is,  $x$  minimizes  $(b - A^*x)'*diag(w)*(b - A^*x)$ .  $w$  typically contains either counts or inverse variances.

`x = lscov(A,b,V)`, where  $V$  is an  $m$ -by- $m$  real symmetric positive definite matrix, returns the generalized least squares solution to the linear system  $A^*x = b$  with covariance matrix proportional to  $V$ , that is,  $x$  minimizes  $(b - A^*x)'*inv(V)*(b - A^*x)$ .

More generally,  $V$  can be positive semidefinite, and `lscov` returns  $x$  that minimizes  $e'*e$ , subject to  $A^*x + T*e = b$ , where the minimization is over  $x$  and  $e$ , and  $T^*T' = V$ . When  $V$  is semidefinite, this problem has a solution only if  $b$  is consistent with  $A$  and  $V$  (that is,  $b$  is in the column space of  $[A \ T]$ ), otherwise `lscov` returns an error.

By default, `lscov` computes the Cholesky decomposition of  $V$  and, in effect, inverts that factor to transform the problem into ordinary least squares. However, if `lscov` determines that  $V$  is semidefinite, it uses an orthogonal decomposition algorithm that avoids inverting  $V$ .

$x = \text{lscov}(A, b, V, \text{alg})$  specifies the algorithm used to compute  $x$  when  $V$  is a matrix.  $\text{alg}$  can have the following values:

- 'chol' uses the Cholesky decomposition of  $V$ .
- 'orth' uses orthogonal decompositions, and is more appropriate when  $V$  is ill-conditioned or singular, but is computationally more expensive.

$[x, \text{stdx}] = \text{lscov}(\dots)$  returns the estimated standard errors of  $x$ . When  $A$  is rank deficient,  $\text{stdx}$  contains zeros in the elements corresponding to the necessarily zero elements of  $x$ .

$[x, \text{stdx}, \text{mse}] = \text{lscov}(\dots)$  returns the mean squared error. If  $b$  is assumed to have covariance matrix  $\sigma^2 V$  (or  $(\sigma^2) \times \text{diag}(1./W)$ ), then  $\text{mse}$  is an estimate of  $\sigma^2$ .

$[x, \text{stdx}, \text{mse}, S] = \text{lscov}(\dots)$  returns the estimated covariance matrix of  $x$ . When  $A$  is rank deficient,  $S$  contains zeros in the rows and columns corresponding to the necessarily zero elements of  $x$ .  $\text{lscov}$  cannot return  $S$  if it is called with multiple right-hand sides, that is, if  $\text{size}(B, 2) > 1$ .

The standard formulas for these quantities, when  $A$  and  $V$  are full rank, are

- $x = \text{inv}(A' * \text{inv}(V) * A) * A' * \text{inv}(V) * B$
- $\text{mse} = B' * (\text{inv}(V) - \text{inv}(V) * A * \text{inv}(A' * \text{inv}(V) * A) * A' * \text{inv}(V)) * B ./ (m - n)$
- $S = \text{inv}(A' * \text{inv}(V) * A) * \text{mse}$
- $\text{stdx} = \text{sqrt}(\text{diag}(S))$

However,  $\text{lscov}$  uses methods that are faster and more stable, and are applicable to rank deficient cases.

$\text{lscov}$  assumes that the covariance matrix of  $B$  is known only up to a scale factor.  $\text{mse}$  is an estimate of that unknown scale factor, and  $\text{lscov}$  scales the outputs  $S$  and  $\text{stdx}$  appropriately. However, if  $V$  is known to be exactly the covariance matrix of  $B$ , then that scaling is unnecessary.

To get the appropriate estimates in this case, you should rescale  $S$  and  $stdx$  by  $1/mse$  and  $\sqrt{1/mse}$ , respectively.

## Algorithms

The vector  $x$  minimizes the quantity  $(A*x-b)'*inv(V)*(A*x-b)$ . The classical linear algebra solution to this problem is

$$x = inv(A'*inv(V)*A)*A'*inv(V)*b$$

but the `lscov` function instead computes the QR decomposition of  $A$  and then modifies  $Q$  by  $V$ .

## Examples

### Example 1 – Computing Ordinary Least Squares

The MATLAB backslash operator (`\`) enables you to perform linear regression by computing ordinary least-squares (OLS) estimates of the regression coefficients. You can also use `lscov` to compute the same OLS estimates. By using `lscov`, you can also compute estimates of the standard errors for those coefficients, and an estimate of the standard deviation of the regression error term:

```
x1 = [.2 .5 .6 .8 1.0 1.1]';
x2 = [.1 .3 .4 .9 1.1 1.4]';
X = [ones(size(x1)) x1 x2];
y = [.17 .26 .28 .23 .27 .34]';
```

```
a = X\y
a =
 0.1203
 0.3284
 -0.1312
```

```
[b,se_b,mse] = lscov(X,y)
b =
 0.1203
 0.3284
 -0.1312
se_b =
 0.0643
```



```

 0.2267
 0.1488
mse =
 0.0015

```

### Example 2 – Computing Weighted Least Squares

Use `lscov` to compute a weighted least-squares (WLS) fit by providing a vector of relative observation weights. For example, you might want to downweight the influence of an unreliable observation on the fit:

```

w = [1 1 1 1 1 .1]';

[bw,sew_b,msew] = lscov(X,y,w)
bw =
 0.1046
 0.4614
 -0.2621
sew_b =
 0.0309
 0.1152
 0.0814
msew =
 3.4741e-004

```

### Example 3 – Computing General Least Squares

Use `lscov` to compute a general least-squares (GLS) fit by providing an observation covariance matrix. For example, your data may not be independent:

```

V = .2*ones(length(x1)) + .8*diag(ones(size(x1)));

[bg,sew_b,mseg] = lscov(X,y,V)
bg =
 0.1203
 0.3284
 -0.1312
sew_b =

```

```
0.0672
0.2267
0.1488
mse =
0.0019
```

## Example 4 – Estimating the Coefficient Covariance Matrix

Compute an estimate of the coefficient covariance matrix for either OLS, WLS, or GLS fits. The coefficient standard errors are equal to the square roots of the values on the diagonal of this covariance matrix:

```
[b,se_b,mse,S] = lscov(X,y);
```

```
S
S =
 0.0041 -0.0130 0.0075
 -0.0130 0.0514 -0.0328
 0.0075 -0.0328 0.0221
```

```
[se_b sqrt(diag(S))]
ans =
 0.0643 0.0643
 0.2267 0.2267
 0.1488 0.1488
```

## References

[1] Strang, G., *Introduction to Applied Mathematics*, Wellesley-Cambridge, 1986, p. 398.

## See Also

lsqnonneg | qr

**Purpose** Solve nonnegative least-squares constraints problem

**Equation** Solves nonnegative least-squares curve fitting problems of the form

$$\min_x \|C \cdot x - d\|_2^2, \text{ where } x \geq 0.$$

**Syntax**

```
x = lsqnonneg(C,d)
x = lsqnonneg(C,d,options)
[x,resnorm] = lsqnonneg(...)
[x,resnorm,residual] = lsqnonneg(...)
[x,resnorm,residual,exitflag] = lsqnonneg(...)
[x,resnorm,residual,exitflag,output] = lsqnonneg(...)
[x,resnorm,residual,exitflag,output,lambda] = lsqnonneg(...)
```

**Description**

`x = lsqnonneg(C,d)` returns the vector `x` that minimizes `norm(C*x-d)` subject to `x >= 0`. `C` and `d` must be real.

`x = lsqnonneg(C,d,options)` minimizes with the optimization parameters specified in the structure `options`. You can define these parameters using the `optimset` function. `lsqnonneg` uses these `options` structure fields:

**Display** Level of display. 'off' displays no output; 'final' displays just the final output; 'notify' (default) displays output only if the function does not converge.

**TolX** Termination tolerance on `x`.

`[x,resnorm] = lsqnonneg(...)` returns the value of the squared 2-norm of the residual: `norm(C*x-d)^2`.

`[x,resnorm,residual] = lsqnonneg(...)` returns the residual, `d-C*x`.

`[x,resnorm,residual,exitflag] = lsqnonneg(...)` returns a value `exitflag` that describes the exit condition of `lsqnonneg`:

# lsqnonneg

---

>0            Indicates that the function converged to a solution  $x$ .  
0             Indicates that the iteration count was exceeded.  
              Increasing the tolerance (TolX parameter in options)  
              may lead to a solution.

`[x,resnorm,residual,exitflag,output] = lsqnonneg(...)` returns a structure output that contains information about the operation in the following fields:

algorithm            'active-set'  
iterations            The number of iterations taken  
message              Exit message

`[x,resnorm,residual,exitflag,output,lambda] = lsqnonneg(...)` returns the dual vector (Lagrange multipliers) `lambda`, where `lambda(i) <= 0` when `x(i)` is (approximately) 0, and `lambda(i)` is (approximately) 0 when `x(i) > 0`.

## Examples

Compare the unconstrained least squares solution to the `lsqnonneg` solution for a 4-by-2 problem:

```
C = [
 0.0372 0.2869
 0.6861 0.7071
 0.6233 0.6245
 0.6344 0.6170];
d = [
 0.8587
 0.1781
 0.0747
 0.8405];
[C\d lsqnonneg(C,d)] =
 -2.5627 0
 3.1108 0.6929
[norm(C*(C\d) - d) norm(C*lsqnonneg(C,d) - d)] =
 0.6674 0.9118
```

The solution from `lsqnonneg` does not fit as well (has a larger residual), as the least squares solution. However, the nonnegative least squares solution has no negative components.

## Algorithms

`lsqnonneg` uses the algorithm described in [1]. The algorithm starts with a set of possible basis vectors and computes the associated dual vector `lambda`. It then selects the basis vector corresponding to the maximum value in `lambda` in order to swap out of the basis in exchange for another possible candidate. This continues until `lambda <= 0`.

## References

[1] Lawson, C.L. and R.J. Hanson, *Solving Least Squares Problems*, Prentice-Hall, 1974, Chapter 23, p. 161.

## See Also

`optimset`

# lsqr

---

## Purpose

LSQR method

## Syntax

```
x = lsqr(A,b)
lsqr(A,b,tol)
lsqr(A,b,tol,maxit)
lsqr(A,b,tol,maxit,M)
lsqr(A,b,tol,maxit,M1,M2)
lsqr(A,b,tol,maxit,M1,M2,x0)
[x,flag] = lsqr(A,b,tol,maxit,M1,M2,x0)
[x,flag,relres] = lsqr(A,b,tol,maxit,M1,M2,x0)
[x,flag,relres,iter] = lsqr(A,b,tol,maxit,M1,M2,x0)
[x,flag,relres,iter,resvec] = lsqr(A,b,tol,maxit,M1,M2,x0)
[x,flag,relres,iter,resvec,lsvec] = lsqr(A,b,tol,maxit,M1,M2,x0)
```

## Description

`x = lsqr(A,b)` attempts to solve the system of linear equations  $A*x=b$  for  $x$  if  $A$  is consistent, otherwise it attempts to solve the least squares solution  $x$  that minimizes  $\text{norm}(b-A*x)$ . The  $m$ -by- $n$  coefficient matrix  $A$  need not be square but it should be large and sparse. The column vector  $b$  must have length  $m$ . You can specify  $A$  as a function handle, `afun`, such that `afun(x, 'notransp')` returns  $A*x$  and `afun(x, 'transp')` returns  $A'*x$ .

“Parameterizing Functions” explains how to provide additional parameters to the function `afun`, as well as the preconditioner function `mfun` described below, if necessary.

If `lsqr` converges, a message to that effect is displayed. If `lsqr` fails to converge after the maximum number of iterations or halts for any reason, a warning message is printed displaying the relative residual  $\text{norm}(b-A*x)/\text{norm}(b)$  and the iteration number at which the method stopped or failed.

`lsqr(A,b,tol)` specifies the tolerance of the method. If `tol` is `[]`, then `lsqr` uses the default,  $1e-6$ .

`lsqr(A,b,tol,maxit)` specifies the maximum number of iterations.

`lsqr(A,b,tol,maxit,M)` and `lsqr(A,b,tol,maxit,M1,M2)` use  $n$ -by- $n$  preconditioner  $M$  or  $M = M1*M2$  and effectively solve the system

$A \cdot \text{inv}(M) \cdot y = b$  for  $y$ , where  $y = M \cdot x$ . If  $M$  is `[]` then `lsqr` applies no preconditioner.  $M$  can be a function `mfun` such that `mfun(x, 'notransp')` returns  $M \setminus x$  and `mfun(x, 'transp')` returns  $M' \setminus x$ .

`lsqr(A,b,tol,maxit,M1,M2,x0)` specifies the  $n$ -by-1 initial guess. If `x0` is `[]`, then `lsqr` uses the default, an all zero vector.

`[x,flag] = lsqr(A,b,tol,maxit,M1,M2,x0)` also returns a convergence flag.

Flag	Convergence
0	<code>lsqr</code> converged to the desired tolerance <code>tol</code> within <code>maxit</code> iterations.
1	<code>lsqr</code> iterated <code>maxit</code> times but did not converge.
2	Preconditioner $M$ was ill-conditioned.
3	<code>lsqr</code> stagnated. (Two consecutive iterates were the same.)
4	One of the scalar quantities calculated during <code>lsqr</code> became too small or too large to continue computing.

Whenever `flag` is not 0, the solution `x` returned is that with minimal norm residual computed over all the iterations. No messages are displayed if you specify the `flag` output.

`[x,flag,relres] = lsqr(A,b,tol,maxit,M1,M2,x0)` also returns an estimate of the relative residual norm  $\|b - A \cdot x\| / \|b\|$ . If `flag` is 0, `relres`  $\leq$  `tol`.

`[x,flag,relres,iter] = lsqr(A,b,tol,maxit,M1,M2,x0)` also returns the iteration number at which `x` was computed, where  $0 \leq \text{iter} \leq \text{maxit}$ .

`[x,flag,relres,iter,resvec] = lsqr(A,b,tol,maxit,M1,M2,x0)` also returns a vector of the residual norm estimates at each iteration, including  $\|b - A \cdot x_0\|$ .

`[x,flag,relres,iter,resvec,lsvec] = lsqr(A,b,tol,maxit,M1,M2,x0)` also returns a vector of estimates of the scaled normal equations residual at each iteration:

$\text{norm}((A \cdot \text{inv}(M))' * (B - A \cdot X)) / \text{norm}(A \cdot \text{inv}(M), 'fro')$ . Note that the estimate of  $\text{norm}(A \cdot \text{inv}(M), 'fro')$  changes, and hopefully improves, at each iteration.

## Examples

### Example 1

```
n = 100;
on = ones(n,1);
A = spdiags([-2*on 4*on -on],-1:1,n,n);
b = sum(A,2);
tol = 1e-8;
maxit = 15;
M1 = spdiags([on/(-2) on],-1:0,n,n);
M2 = spdiags([4*on -on],0:1,n,n);

x = lsqr(A,b,tol,maxit,M1,M2);
```

displays the following message:

```
lsqr converged at iteration 11 to a solution with relative
residual 3.5e-009
```

### Example 2

This example replaces the matrix  $A$  in Example 1 with a handle to a matrix-vector product function `afun`. The example is contained in a function `run_lsqr` that

- Calls `lsqr` with the function handle `@afun` as its first argument.
- Contains `afun` as a nested function, so that all variables in `run_lsqr` are available to `afun`.

The following shows the code for `run_lsqr`:

```
function x1 = run_lsqr
n = 100;
on = ones(n,1);
A = spdiags([-2*on 4*on -on],-1:1,n,n);
b = sum(A,2);
```



```

tol = 1e-8;
maxit = 15;
M1 = spdiags([on/(-2) on],-1:0,n,n);
M2 = spdiags([4*on -on],0:1,n,n);
x1 = lsqr(@afun,b,tol,maxit,M1,M2);

function y = afun(x,transp_flag)
 if strcmp(transp_flag,'transp') % y = A'*x
 y = 4 * x;
 y(1:n-1) = y(1:n-1) - 2 * x(2:n);
 y(2:n) = y(2:n) - x(1:n-1);
 elseif strcmp(transp_flag,'notransp') % y = A*x
 y = 4 * x;
 y(2:n) = y(2:n) - 2 * x(1:n-1);
 y(1:n-1) = y(1:n-1) - x(2:n);
 end
end
end

```

When you enter

```
x1=run_lsqr;
```

MATLAB software displays the message

```
lsqr converged at iteration 11 to a solution with relative
residual 3.5e-009
```

## References

- [1] Barrett, R., M. Berry, T. F. Chan, et al., *Templates for the Solution of Linear Systems: Building Blocks for Iterative Methods*, SIAM, Philadelphia, 1994.
- [2] Paige, C. C. and M. A. Saunders, "LSQR: An Algorithm for Sparse Linear Equations And Sparse Least Squares," *ACM Trans. Math. Soft.*, Vol.8, 1982, pp. 43-71.

## See Also

```

bicg | bicgstab | cgs | gmres | minres | norm | pcg | qmr | symmlq
| function_handle

```

**Purpose** Determine less than

**Syntax** A < B  
lt(A,B)

**Description** A < B returns an array with elements set to logical 1 (true) where A is less than B; otherwise, it returns logical 0 (false). The test compares only the real part of numeric arrays. lt returns logical 0 (false) where A or B have NaN or undefined categorical elements.

lt(A,B) is an alternate way to execute A < B, but is rarely used. It enables operator overloading for classes.

**Input Arguments**

**A - Left array**  
numeric array | logical array | character array | ordinal categorical array

Left array, specified as a numeric array, logical array, character array, or categorical array. Inputs A and B must be the same size unless one is a scalar. A scalar input expands into an array of the same size as the other input.

If one input is an ordinal categorical array, the other input can be an ordinal categorical array, a cell array of strings, or a single string. A single string expands into a cell array of strings of the same size as the other input. If both inputs are ordinal categorical arrays, they must have the same sets of categories, including their order. See “Compare Categorical Array Elements” for more details.

**B - Right array**  
numeric array | logical array | character array | ordinal categorical array

Right array, specified as a numeric array, logical array, character array, or categorical array. Inputs A and B must be the same size unless one is a scalar. A scalar input expands into an array of the same size as the other input.

If one input is an ordinal categorical array, the other input can be an ordinal categorical array, a cell array of strings, or a single string. A single string expands into a cell array of strings of the same size as the other input. If both inputs are ordinal categorical arrays, they must have the same sets of categories, including their order. See “Compare Categorical Array Elements” for more details.

## Examples

### Test Vector Elements

Determine if vector elements are less than a given value.

Create a numeric vector.

```
A = [1 12 18 7 9 11 2 15];
```

Test the vector for elements that are less than 12.

```
A < 12
```

```
ans =
```

```
 1 0 0 1 1 1 1 0
```

The result is a vector with values of logical 1 (true) where the elements of A satisfy the expression.

Use the vector of logical values as an index to view the values in A that are less than 12.

```
A(A < 12)
```

```
ans =
```

```
 1 7 9 11 2
```

The result is a subset of the elements in A.

## Replace Elements of Matrix

Create a matrix.

```
A = magic(4)
```

```
A =
```

```
 16 2 3 13
 5 11 10 8
 9 7 6 12
 4 14 15 1
```

Replace all values less than 9 with the value 10.

```
A(A < 9) = 10
```

```
A =
```

```
 16 10 10 13
 10 11 10 10
 9 10 10 12
 10 14 15 10
```

The result is a new matrix whose smallest element is 9.

## Compare Values in Categorical Array

Create an ordinal categorical array.

```
A = categorical({'large' 'medium' 'small'; 'medium' ...
 'small' 'large'},{'small' 'medium' 'large'},'Ordinal',1)
```

```
A =
```

```
 large medium small
 medium small large
```

The array has three categories: 'small', 'medium', and 'large'.

Find all values less than the category 'medium'.

```
A < 'medium'
```

```
ans =
```

```
 0 0 1
 0 1 0
```

A value of logical 1 (true) indicates a value less than the category 'medium'.

Compare the rows of A.

```
A(1,:) < A(2,:)
```

```
ans =
```

```
 0 0 1
```

The function returns logical 1 (true) where the first row has a category value less than the second row.

### Test Complex Numbers

Create a vector of complex numbers.

```
A = [1+i 2-2i 1+3i 1-2i 5-i];
```

Find the values that are less than 3.

```
A(A < 3)
```

```
ans =
```

```
1.0000 + 1.0000i 2.0000 - 2.0000i 1.0000 + 3.0000i 1.0000 - 2.0000i
```

It compares only the real part of the elements in A.

Use `abs` to find which elements are within a radius of 3 from the origin.

```
A(abs(A) < 3)
```

```
ans =
```

```
1.0000 + 1.0000i 2.0000 - 2.0000i 1.0000 - 2.0000i
```

The result has one less element. The element  $1.0000 + 3.0000i$  is not within a radius of 3 from the origin.

## See Also

[eq](#) | [ge](#) | [gt](#) | [le](#) | [ne](#)

## Concepts

- “Ordinal Categorical Arrays”

**Purpose**

LU matrix factorization

**Syntax**

```
Y = lu(A)
[L,U] = lu(A)
[L,U,P] = lu(A)
[L,U,P,Q] = lu(A)
[L,U,P,Q,R] = lu(A)
[...] = lu(A,'vector')
[...] = lu(A,thresh)
[...] = lu(A,thresh,'vector')
```

**Description**

The `lu` function expresses a matrix  $A$  as the product of two essentially triangular matrices, one of them a permutation of a lower triangular matrix and the other an upper triangular matrix. The factorization is often called the  $LU$ , or sometimes the  $LR$ , factorization.  $A$  can be rectangular.

`Y = lu(A)` returns matrix  $Y$  that, for sparse  $A$ , contains the strictly lower triangular  $L$ , i.e., without its unit diagonal, and the upper triangular  $U$  as submatrices. That is, if `[L,U,P] = lu(A)`, then  $Y = U+L - \text{eye}(\text{size}(A))$ . For nonsparse  $A$ ,  $Y$  is the output from the LAPACK `dgetrf` or `zgetrf` routine. The permutation matrix  $P$  is not returned.

`[L,U] = lu(A)` returns an upper triangular matrix in  $U$  and a permuted lower triangular matrix in  $L$  such that  $A = L*U$ . Return value  $L$  is a product of lower triangular and permutation matrices.

`[L,U,P] = lu(A)` returns an upper triangular matrix in  $U$ , a lower triangular matrix  $L$  with a unit diagonal, and a permutation matrix  $P$ , such that  $L*U = P*A$ . The statement `lu(A,'matrix')` returns identical output values.

`[L,U,P,Q] = lu(A)` for sparse nonempty  $A$ , returns a unit lower triangular matrix  $L$ , an upper triangular matrix  $U$ , a row permutation matrix  $P$ , and a column reordering matrix  $Q$ , so that  $P*A*Q = L*U$ . If  $A$  is empty or not sparse, `lu` displays an error message. The statement `lu(A,'matrix')` returns identical output values.

`[L,U,P,Q,R] = lu(A)` returns unit lower triangular matrix L, upper triangular matrix U, permutation matrices P and Q, and a diagonal scaling matrix R so that  $P*(R\backslash A)*Q = L*U$  for sparse non-empty A. Typically, but not always, the row-scaling leads to a sparser and more stable factorization. The statement `lu(A, 'matrix')` returns identical output values.

`[...] = lu(A, 'vector')` returns the permutation information in two row vectors p and q. You can specify from 1 to 5 outputs. Output p is defined as  $A(p,:) = L*U$ , output q is defined as  $A(p,q) = L*U$ , and output R is defined as  $R(:,p)\backslash A(:,q) = L*U$ .

`[...] = lu(A,thresh)` controls pivoting. This syntax applies to sparse matrices only. The `thresh` input is a one- or two-element vector of type `single` or `double` that defaults to `[0.1, 0.001]`. If A is a square matrix with a mostly symmetric structure and mostly nonzero diagonal, MATLAB uses a symmetric pivoting strategy. For this strategy, the diagonal where

$$A(i,j) \geq \text{thresh}(2) * \max(\text{abs}(A(j:m,j)))$$

is selected. If the diagonal entry fails this test, a pivot entry below the diagonal is selected, using `thresh(1)`. In this case, L has entries with absolute value  $1/\min(\text{thresh})$  or less.

If A is not as described above, MATLAB uses an asymmetric strategy. In this case, the sparsest row i where

$$A(i,j) \geq \text{thresh}(1) * \max(\text{abs}(A(j:m,j)))$$

is selected. A value of 1.0 results in conventional partial pivoting. Entries in L have an absolute value of  $1/\text{thresh}(1)$  or less. The second element of the `thresh` input vector is not used when MATLAB uses an asymmetric strategy.

Smaller values of `thresh(1)` and `thresh(2)` tend to lead to sparser LU factors, but the solution can become inaccurate. Larger values can lead to a more accurate solution (but not always), and usually an increase in the total work and memory usage. The statement `lu(A,thresh, 'matrix')` returns identical output values.



[...] = lu(A,thresh,'vector') controls the pivoting strategy and also returns the permutation information in row vectors, as described above. The thresh input must precede 'vector' in the input argument list.

---

**Note** In rare instances, incorrect factorization results in  $P*A*Q \neq L*U$ . Increase thresh, to a maximum of 1.0 (regular partial pivoting), and try again.

---

## Tips

Most of the algorithms for computing LU factorization are variants of Gaussian elimination. The factorization is a key step in obtaining the inverse with inv and the determinant with det. It is also the basis for the linear equation solution or matrix division obtained with \ and /.

## Arguments

A	Rectangular matrix to be factored.
thresh	Pivot threshold for sparse matrices. Valid values are in the interval [0, 1]. If you specify the fourth output Q, the default is 0.1. Otherwise, the default is 1.0.
L	Factor of A. Depending on the form of the function, L is either a unit lower triangular matrix, or else the product of a unit lower triangular matrix with P'.
U	Upper triangular matrix that is a factor of A.
P	Row permutation matrix satisfying the equation $L*U = P*A$ , or $L*U = P*A*Q$ . Used for numerical stability.
Q	Column permutation matrix satisfying the equation $P*A*Q = L*U$ . Used to reduce fill-in in the sparse case.
R	Row-scaling matrix

**Examples****Example 1**

Start with

$$A = \begin{bmatrix} 1 & 2 & 3 \\ 4 & 5 & 6 \\ 7 & 8 & 0 \end{bmatrix};$$

To see the LU factorization, call `lu` with two output arguments.

$$[L1,U] = \text{lu}(A)$$

L1 =

$$\begin{bmatrix} 0.1429 & 1.0000 & 0 \\ 0.5714 & 0.5000 & 1.0000 \\ 1.0000 & 0 & 0 \end{bmatrix}$$

U =

$$\begin{bmatrix} 7.0000 & 8.0000 & 0 \\ 0 & 0.8571 & 3.0000 \\ 0 & 0 & 4.5000 \end{bmatrix}$$

Notice that L1 is a permutation of a lower triangular matrix: if you switch rows 2 and 3, and then switch rows 1 and 2, the resulting matrix is lower triangular and has 1s on the diagonal. Notice also that U is upper triangular. To check that the factorization does its job, compute the product

`L1*U`

which returns the original A. The inverse of the example matrix,  $X = \text{inv}(A)$ , is actually computed from the inverses of the triangular factors

$$X = \text{inv}(U) * \text{inv}(L1)$$

Using three arguments on the left side to get the permutation matrix as well,

$$[L2,U,P] = \text{lu}(A)$$

returns a truly lower triangular L2, the same value of U, and the permutation matrix P.

L2 =

1.0000	0	0
0.1429	1.0000	0
0.5714	0.5000	1.0000

U =

7.0000	8.0000	0
0	0.8571	3.0000
0	0	4.5000

P =

0	0	1
1	0	0
0	1	0

Note that  $L2 = P*L1$ .

P\*L1

ans =

1.0000	0	0
0.1429	1.0000	0
0.5714	0.5000	1.0000

To verify that  $L2*U$  is a permuted version of A, compute  $L2*U$  and subtract it from  $P*A$ :

$P*A - L2*U$

ans =

0	0	0
0	0	0
0	0	0

In this case,  $\text{inv}(U) * \text{inv}(L)$  results in the permutation of  $\text{inv}(A)$  given by  $\text{inv}(P) * \text{inv}(A)$ .

The determinant of the example matrix is

$$d = \det(A)$$

$$d = 27$$

It is computed from the determinants of the triangular factors

$$d = \det(L) * \det(U)$$

The solution to  $Ax = b$  is obtained with matrix division

$$x = A \backslash b$$

The solution is actually computed by solving two triangular systems

$$y = L \backslash b$$

$$x = U \backslash y$$

### **Example 2**

The 1-norm of their difference is within roundoff error, indicating that  $L*U = P*B*Q$ .

Generate a 60-by-60 sparse adjacency matrix of the connectivity graph of the Buckminster-Fuller geodesic dome.

$$B = \text{bucky};$$

Use the sparse matrix syntax with four outputs to get the row and column permutation matrices.

$$[L,U,P,Q] = \text{lu}(B);$$

Apply the permutation matrices to B, and subtract the product of the lower and upper triangular matrices.

$$Z = P*B*Q - L*U;$$

```
norm(Z,1)

ans =
 7.9936e-015
```

### Example 3

This example illustrates the benefits of using the 'vector' option. Note how much memory is saved by using the `lu(F, 'vector')` syntax.

```
F = gallery('uniformdata',[1000 1000],0);
g = sum(F,2);
[L,U,P] = lu(F);
[L,U,p] = lu(F,'vector');
whos P p
```

Name	Size	Bytes	Class	Attributes
P	1000x1000	8000000	double	
p	1x1000	8000	double	

The following two statements are equivalent. The first typically requires less time:

```
x = U \ (L \ (g(p, :)));
y = U \ (L \ (P * g));
```

### See Also

`cond` | `det` | `inv` | `ilu` | `qr` | `rref`

# magic

---

**Purpose** Magic square

**Syntax** `M = magic(n)`

**Description** `M = magic(n)` returns an  $n$ -by- $n$  matrix constructed from the integers 1 through  $n^2$  with equal row and column sums. The order  $n$  must be a scalar greater than or equal to 3.

**Tips** A magic square, scaled by its magic sum, is doubly stochastic.

**Examples** The magic square of order 3 is

```
M = magic(3)
```

```
M =
```

```
 8 1 6
 3 5 7
 4 9 2
```

This is called a magic square because the sum of the elements in each column is the same.

```
sum(M) =
```

```
 15 15 15
```

And the sum of the elements in each row, obtained by transposing twice, is the same.

```
sum(M')' =
```

```
 15
 15
 15
```

This is also a special magic square because the diagonal elements have the same sum.

```
sum(diag(M)) =
```

```
15
```

The value of the characteristic sum for a magic square of order  $n$  is

```
sum(1:n^2)/n
```

which, when  $n = 3$ , is 15.

## Algorithms

There are three different algorithms:

- $n$  odd
- $n$  even but not divisible by four
- $n$  divisible by four

To make this apparent, type

```
for n = 3:20
 A = magic(n);
 r(n) = rank(A);
end
```

For  $n$  odd, the rank of the magic square is  $n$ . For  $n$  divisible by 4, the rank is 3. For  $n$  even but not divisible by 4, the rank is  $n/2 + 2$ .

```
[(3:20)', r(3:20)']
```

```
ans =
 3 3
 4 3
 5 5
 6 5
 7 7
 8 3
 9 9
 10 7
 11 11
 12 3
```

# magic

---

13	13
14	9
15	15
16	3
17	17
18	11
19	19
20	3

Plotting  $A$  for  $n = 18, 19, 20$  shows the characteristic plot for each category.

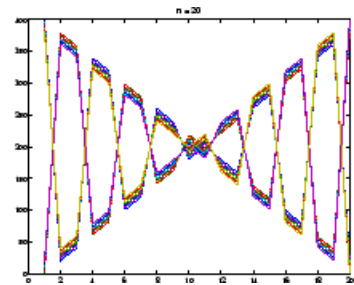
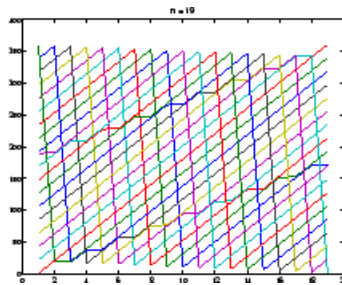
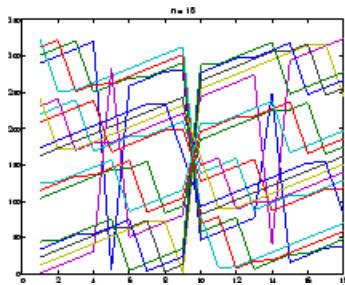

## Limitations

If you supply  $n$  less than 3, `magic` returns either a nonmagic square, or else the degenerate magic squares `1` and `[]`.

## See Also

`ones` | `rand`



**Purpose** Create 4-by-4 transform matrix

**Syntax**

```
M = makehgtform
M = makehgtform('translate',[tx ty tz])
M = makehgtform('scale',s)
M = makehgtform('scale',[sx,sy,sz])
M = makehgtform('xrotate',t)
M = makehgtform('yrotate',t)
M = makehgtform('zrotate',t)
M = makehgtform('axisrotate',[ax,ay,az],t)
```

**Description** Use `makehgtform` to create transform matrices for translation, scaling, and rotation of graphics objects. Apply the transform to graphics objects by assigning the transform to the `Matrix` property of a parent `hgtransform` object. See [Examples](#) for more information.

`M = makehgtform` returns an identity transform.

`M = makehgtform('translate',[tx ty tz])` or `M = makehgtform('translate',tx,ty,tz)` returns a transform that translates along the *x*-axis by `tx`, along the *y*-axis by `ty`, and along the *z*-axis by `tz`.

`M = makehgtform('scale',s)` returns a transform that scales uniformly along the *x*-, *y*-, and *z*-axes.

`M = makehgtform('scale',[sx,sy,sz])` returns a transform that scales along the *x*-axis by `sx`, along the *y*-axis by `sy`, and along the *z*-axis by `sz`.

`M = makehgtform('xrotate',t)` returns a transform that rotates around the *x*-axis by `t` radians.

`M = makehgtform('yrotate',t)` returns a transform that rotates around the *y*-axis by `t` radians.

`M = makehgtform('zrotate',t)` returns a transform that rotates around the *z*-axis by `t` radians.

`M = makehgtform('axisrotate',[ax,ay,az],t)` Rotate around axis [`ax ay az`] by `t` radians.

# makehgtform

---

Note that you can specify multiple operations in one call to `makehgtform` and the MATLAB software returns a transform matrix that is the result of concatenating all specified operations. For example,

```
m = makehgtform('xrotate',pi/2,'yrotate',pi/2);
```

is the same as

```
mx = makehgtform('xrotate',pi/2);
my = makehgtform('yrotate',pi/2);
m = mx*my;
```

## See Also

[hggroup](#) | [hgtransform](#) | [Hgtransform Properties](#)

## How To

- “Group Objects”

<b>Purpose</b>	Map values to unique keys
<b>Description</b>	A Map object is a data structure that allows you to retrieve values using a corresponding key. Keys can be real numbers or text strings and provide more flexibility for data access than array indices, which must be positive integers. Values can be scalar or nonscalar arrays.
<b>Construction</b>	<p><code>mapObj = containers.Map</code> constructs an empty Map container <code>mapObj</code>.</p> <p><code>mapObj = containers.Map(keySet,valueSet)</code> constructs a Map that contains one or more values and a unique key for each value.</p> <p><code>mapObj = containers.Map(keySet,valueSet,'UniformValues',isUniform)</code> specifies whether all values must be uniform (either all scalars of the same data type, or all strings). Possible values for <code>isUniform</code> are logical true (1) or false (0).</p> <p><code>mapObj = containers.Map('KeyType',kType,'ValueType',vType)</code> constructs an empty Map object and sets the <code>KeyType</code> and <code>ValueType</code> properties. The order of the key type and value type argument pairs is not important, but both pairs are required.</p>

## Input Arguments

### **keySet**

1-by-n array that specifies n unique keys for the map.

All keys in a Map object are real numeric values or all keys are strings. If  $n > 1$  and the keys are strings, `keySet` must be a cell array. The number of keys in `keySet` must equal the number of values in `valueSet`.

### **valueSet**

1-by-n array of any class that specifies n values for the map. The number of values in `valueSet` must equal the number of keys in `keySet`.

### **'UniformValues'**

# containers.Map

---

Parameter string to use with the `isUniform` argument.

## **isUniform**

Logical value that specifies whether all values are uniform. If `isUniform` is `true` (1), all values must be scalars of the same data type, or all values must be strings. If `isUniform` is `false` (0), then `containers.Map` sets the `ValueType` to `'any'`.

**Default:** `true` for empty `Map` objects, otherwise determined by the data types of values in `valueSet`.

## **'KeyType'**

Parameter string to use with the `kType` argument.

## **kType**

String that specifies the data type for the keys. Possible values are `'char'`, `'double'`, `'single'`, `'int32'`, `'uint32'`, `'int64'`, or `'uint64'`.

**Default:** `'char'` for empty `Map` objects, otherwise determined by the data types of keys in `keySet`. If you specify keys of different numeric types, `kType` is `'double'`.

## **'ValueType'**

Literal string parameter to use with the `vType` argument.

## **vType**

String that specifies the data type for the values. Possible values are `'any'`, `'char'`, `'logical'`, `'double'`, `'single'`, `'int8'`, `'uint8'`, `'int16'`, `'uint16'`, `'int32'`, `'uint32'`, `'int64'`, or `'uint64'`.

**Default:** `'any'` when you create an empty `Map` object or when you specify values of different sizes or types, otherwise determined by the data type of `valueSet`.

## Properties

### Count

Unsigned 64-bit integer that represents the total number of key-value pairs contained in the `Map` object. Read only.

### KeyType

Character array that indicates the data type of all keys in the `Map` object. The default `KeyType` for empty `Map` objects is `'char'`. Otherwise, `KeyType` is determined from the data type of the `keySet` inputs. Read only.

### ValueType

Character array that indicates the data type of all values in the `Map` object. If you construct an empty `Map` object or specify values with different data types, then the value of `ValueType` is `'any'`. Otherwise, `ValueType` is determined from the data type of the `valueSet` inputs. Read only.

## Methods

<code>isKey</code>	Determine if <code>containers.Map</code> object contains key
<code>keys</code>	Identify keys of <code>containers.Map</code> object
<code>length</code>	Length of <code>containers.Map</code> object
<code>remove</code>	Remove key-value pairs from <code>containers.Map</code> object
<code>size</code>	Size of <code>containers.Map</code> object
<code>values</code>	Identify values in <code>containers.Map</code> object

## Copy Semantics

Handle. To learn how handle classes affect copy operations, see [Copying Objects in the MATLAB documentation](#).

# containers.Map

---

## Examples

### Construct a Map and View Properties

Construct a Map object that contains rainfall data for several months:

```
keySet = {'Jan', 'Feb', 'Mar', 'Apr'};
valueSet = [327.2, 368.2, 197.6, 178.4];
mapObj = containers.Map(keySet,valueSet)
```

This code returns a description of the map, including the property values:

```
mapObj =

 containers.Map handle
 Package: containers

 Properties:
 Count: 4
 KeyType: 'char'
 ValueType: 'double'

 Methods, Events, Superclasses
```

Get a specific property using dot notation, such as

```
mapObj.Count
```

which returns

```
ans =

 4
```

### Look Up Values in a Map

Use the map created in the previous example to find the rainfall data for February:

```
rainFeb = mapObj('Feb')
```

This code returns

```
rainFeb =
 368.2000
```

## Add a Single Value and Key to a Map

Add data for the month of May to the map created in the first example:

```
mapObj('May') = 100.0;
```

## Add Multiple Values and Keys by Concatenating Maps

Create a map that contains rainfall data for June, July, and August, and add the data to `mapObj` (from previous examples):

```
keySet = {'Jun', 'Jul', 'Aug'};
valueSet = [69.9, 32.3, 37.3];
newMap = containers.Map(keySet,valueSet);
```

```
mapObj = [mapObj; newMap];
```

Map objects only support vertical concatenation (that is, adding columns with a semicolon, `;`). When concatenating maps, the data type of all values must be consistent with the `ValueType` of the leftmost map. In this example, both maps have the a `ValueType` of `double`.

## Get the Keys or Values in a Map

Determine all the keys of `mapObj` (from previous examples) by calling the `keys` method:

```
allKeys = keys(mapObj)
```

This method returns the keys in alphabetical order:

```
allKeys =
 'Apr' 'Aug' 'Feb' 'Jan' 'Jul' 'Jun' 'Mar' 'M
```

Get multiple values from the map by calling the `values` method. Like the `keys` method, you can request all values with the syntax `values(mapObj)`. Alternatively, request values for specific keys. For example, view the values for March, April, and May in `mapObj`:

# containers.Map

---

```
springValues = values(mapObj, {'Mar', 'Apr', 'May'})
```

This method returns the values in a cell array, in the order corresponding to the specified keys:

```
springValues =
 [197.6000] [178.4000] [100]
```

## Remove Keys and Values

Remove the data for March and April from mapObj (from previous examples) by calling the remove method, and view the remaining keys:

```
remove(mapObj, {'Mar', 'Apr'});
keys(mapObj)
```

This code returns

```
ans =
 'Aug' 'Feb' 'Jan' 'Jul' 'Jun' 'May'
```

## Create a Map with Nonscalar Values

Map integer keys to nonscalar arrays, and view the value for one of the keys:

```
keySet = [5,10,15];
valueSet = {magic(5),magic(10),magic(15)};
mapObj = containers.Map(keySet,valueSet);
mapObj(5)
```

This code returns

```
ans =
 17 24 1 8 15
 23 5 7 14 16
 4 6 13 20 22
 10 12 19 21 3
 11 18 25 2 9
```



## Construct an Empty Map

Construct a map with no values, but set the `KeyType` and `ValueType` properties:

```
mapObj = containers.Map('KeyType','char','ValueType','int32')
```

This code returns

```
mapObj =

 containers.Map handle
 Package: containers

 Properties:
 Count: 0
 KeyType: 'char'
 ValueType: 'int32'
```

Methods, Events, Superclasses

## Specify Whether Values Are Uniform

Construct a map with numeric values, and specify that the values do not have to be uniform:

```
keySet = {'a','b','c'};
valueSet = {1,2,3};
mapObj = containers.Map(keySet,valueSet,'UniformValues',false);
```

This map allows nonnumeric values, so

```
mapObj('d') = 'OK';
values(mapObj)
```

returns

```
ans =
 [1] [2] [3] 'OK'
```

# containers.Map

---

## See Also

keys | isKey | values

**Purpose** Convert array to cell array with potentially different sized cells

**Syntax**

```
C = mat2cell(A,dim1Dist,...,dimNDist)
C = mat2cell(A,rowDist)
```

**Description** `C = mat2cell(A,dim1Dist,...,dimNDist)` divides array `A` into smaller arrays within cell array `C`. Vectors `dim1Dist,...,dimNDist` specify how to divide the rows, columns, and (when applicable) higher dimensions of `A`.

`C = mat2cell(A,rowDist)` divides array `A` into an `n`-by-1 cell array `C`, where `n == numel(rowDist)`.

**Input Arguments**

**A**  
Any type of array.

**dim1Dist,...,dimNDist**

Numeric vectors that describe how to divide each dimension of `A`. For example, this command

```
c = mat2cell(x, [10, 20, 30], [25, 25])
```

divides a 60-by-50 array into six arrays contained in a cell array.

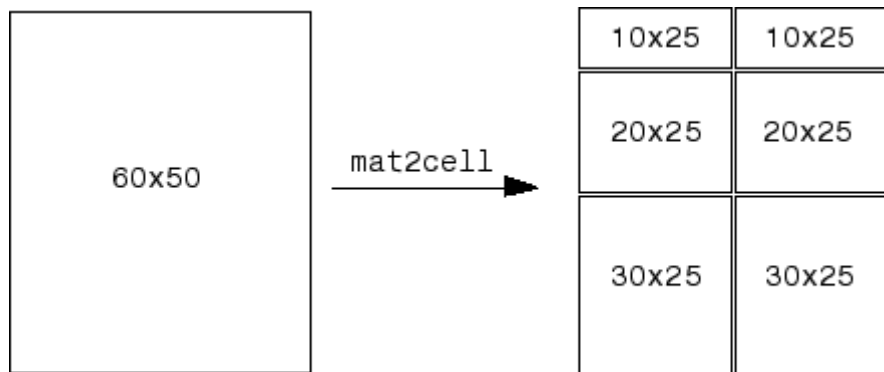

# mat2cell

---

For the  $k$ th dimension, `sum(dimkDist) == size(A, k)`.

If the  $k$ th dimension of  $A$  is zero, set the corresponding `dimkDist` to the empty array, `[]`. For example,

```
a = rand(3, 0, 4);
c = mat2cell(a, [1, 2], [], [2, 1, 1]);
```

## rowDist

Numeric vector that describes how to divide the rows of  $A$ . When you do not specify distributions for any other dimension, the `mat2cell` function creates an  $n$ -by-1 cell array  $C$ , where  $n == \text{numel}(\text{rowDist})$ .

## Output Arguments

### C

Cell array. The  $k$ th dimension of array  $C$  is given by `size(C, k) == numel(dimkDist)`. The  $k$ th dimension of the  $i$ th cell of  $C$  is given by `size(C{i}, k) == dimkDist(i)`.

## Examples

Divide the 5-by-4 matrix  $X$  into 2-by-3 and 2-by-2 matrices contained in a cell array.

```
X = reshape(1:20,5,4)'
C = mat2cell(X, [2 2], [3 2])
celldisp(C)
```

This code returns

```
X =
 1 2 3 4 5
 6 7 8 9 10
 11 12 13 14 15
 16 17 18 19 20
```

```
C =
 [2x3 double] [2x2 double]
 [2x3 double] [2x2 double]
```

```

C{1,1} =
 1 2 3
 6 7 8

C{2,1} =
 11 12 13
 16 17 18

C{1,2} =
 4 5
 9 10

C{2,2} =
 14 15
 19 20

```

---

Divide X (created in the previous example) into a 2-by-1 cell array.

```

C = mat2cell(X, [1 3])
celldisp(C)

```

This code returns

```

C =
 [1x5 double]
 [3x5 double]

C{1} =
 1 2 3 4 5

C{2} =
 6 7 8 9 10
 11 12 13 14 15
 16 17 18 19 20

```

## See Also

[cell2mat](#) | [num2cell](#)

# mat2str

---

**Purpose** Convert matrix to string

**Syntax**

```
str = mat2str(A)
str = mat2str(A,n)
str = mat2str(A, 'class')
str = mat2str(A, n, 'class')
```

**Description**

`str = mat2str(A)` converts matrix `A` into a string. This string is suitable for input to the `eval` function such that `eval(str)` produces the original matrix to within 15 digits of precision.

`str = mat2str(A,n)` converts matrix `A` using `n` digits of precision.

`str = mat2str(A, 'class')` creates a string with the name of the class of `A` included. This option ensures that the result of evaluating `str` will also contain the class information.

`str = mat2str(A, n, 'class')` uses `n` digits of precision and includes the class information.

**Limitations** The `mat2str` function is intended to operate on scalar, vector, or rectangular array inputs only. An error will result if `A` is a multidimensional array.

## Examples

### Example 1

Consider the matrix

```
x = [3.85 2.91; 7.74 8.99]
x =
 3.8500 2.9100
 7.7400 8.9900
```

The statement

```
A = mat2str(x)
```

produces

```
A =
 [3.85 2.91;7.74 8.99]
```

where A is a string of 21 characters, including the square brackets, spaces, and a semicolon.

`eval(mat2str(x))` reproduces x.

## Example 2

Create a 1-by-6 matrix of signed 16-bit integers, and then use `mat2str` to convert the matrix to a 1-by-33 character array, A. Note that output string A includes the class name, `int16`:

```
x1 = int16([-300 407 213 418 32 -125]);
```

```
A = mat2str(x1, 'class')
```

```
A =
 int16([-300 407 213 418 32 -125])
```

```
class(A)
```

```
ans =
 char
```

Evaluating the string A gives you an output x2 that is the same as the original `int16` matrix:

```
x2 = eval(A);
```

```
if isnumeric(x2) && isa(x2, 'int16') && all(x2 == x1)
 disp 'Conversion back to int16 worked'
end
```

```
Conversion back to int16 worked
```

## See Also

`num2str` | `int2str` | `str2num` | `sprintf` | `fprintf`

# material

---

**Purpose** Control reflectance properties of surfaces and patches

**Syntax**

```
material shiny
material dull
material metal
material([ka kd ks])
material([ka kd ks n])
material([ka kd ks n sc])
material default
```

**Description** `material` sets the lighting characteristics of surface and patch objects.

`material shiny` sets the reflectance properties so that the object has a high specular reflectance relative to the diffuse and ambient light, and the color of the specular light depends only on the color of the light source.

`material dull` sets the reflectance properties so that the object reflects more diffuse light and has no specular highlights, but the color of the reflected light depends only on the light source.

`material metal` sets the reflectance properties so that the object has a very high specular reflectance, very low ambient and diffuse reflectance, and the color of the reflected light depends on both the color of the light source and the color of the object.

`material([ka kd ks])` sets the ambient/diffuse/specular strength of the objects.

`material([ka kd ks n])` sets the ambient/diffuse/specular strength and specular exponent of the objects.

`material([ka kd ks n sc])` sets the ambient/diffuse/specular strength, specular exponent, and specular color reflectance of the objects.

`material default` sets the ambient/diffuse/specular strength, specular exponent, and specular color reflectance of the objects to their defaults.



## Tips

The `material` command sets the `AmbientStrength`, `DiffuseStrength`, `SpecularStrength`, `SpecularExponent`, and `SpecularColorReflectance` properties of all surface and patch objects in the axes. There must be visible `light` objects in the axes for lighting to be enabled. Look at the `material.m` file to see the actual values set (enter the command `type material`).

## See Also

`light` | `lighting` | `patch` | `surface`

## How To

- “Lighting Overview”

# matfile

---

**Purpose** Access and change variables directly in MAT-files, without loading into memory

**Syntax**  
`m = matfile(filename)`  
`m = matfile(filename, 'Writable', isWritable)`

**Description** `m = matfile(filename)` creates a MAT-file object, `m`, connected to the MAT-file named `filename`. The object allows you to access and change variables directly in a MAT-file, without having to load the variables into memory.

The partial loading and saving that the `matfile` function provides requires less memory than the `load` and `save` commands, which always operate on entire variables.

`m = matfile(filename, 'Writable', isWritable)` enables or disables write access to the file.

## Input Arguments

### **filename - Name of MAT-file**

string

Name of a MAT-file, specified as a string. If the file is not in the current folder, `filename` must include a full or a relative path. If `filename` does not include an extension, then `matfile` appends `.mat`.

If the file does not exist, then `matfile` creates a Version 7.3 MAT-file on the first assignment to a variable.

`matfile` only supports efficient partial loading and saving for MAT-files in Version 7.3 format. If you index into a variable in a Version 7 (the current default) or earlier MAT-file, MATLAB warns and temporarily loads the entire contents of the variable.

**Example:** `'myFile.mat'`

### **Data Types**

char

### **isWritable - Write access to MAT-file**

true | false

Write access to the MAT-file, specified as either `true` or `false`.

- `true` enables saving to the MAT-file. If the file is read only, MATLAB changes the system permissions with the `fileattrib` function.
- `false` disables saving to the MAT-file. MATLAB does not change the system permissions.

The default value is `true` for new files, and `false` for existing files.

### Data Types

logical

## Output Arguments

### **m** - MAT-file object

`matlab.io.MatFile` object

MAT-file object connected to a MAT-file.

Access variables in the MAT-file with dot notation similar to accessing fields of structure arrays:

- To load part of variable `varName` from the MAT-file corresponding to `m`, call:

```
loadedData = m.varName(indices);
```

- To save part of variable `varName` to the MAT-file corresponding to `m`, call:

```
m.varName(indices) = dataToSave;
```

When accessing variables, specify indices for all dimensions. Indices can be a single value, an equally spaced range of increasing values, or a colon (`:`); for example:

```
m.varName(100:500,200:600)
```

```
m.varName(:,501:1000)
```

```
m.varName(1:2:1000,80)
```

## Examples

### Load Entire Variable

Load variable `topo` from the example file, `topography.mat`.

Open the example MAT-file, `topography.mat`.

```
filename = 'topography.mat';
m = matfile(filename);
```

Read the variable `topo` from the MAT-file.

```
topo = m.topo;
```

MATLAB loads the entire variable, `topo`, into the workspace.

### Save Entire Variable to Existing MAT-file

Generate a 20-by-20 example array, `x`, and save it to a MAT-file called `myFile.mat`.

```
x = magic(20);
save('myFile.mat', 'x');
```

Create a MAT-file object connected to the existing MAT-file named `myFile.mat`. Enable write access to the MAT-file by setting `Writable` to `true`.

```
m = matfile('myFile.mat', 'Writable', true);
```

Generate a 15-by-15 example array, `y`.

```
y = magic(15);
```

Save `y` to the MAT-file. Specify the variable in the MAT-file using dot notation similar to accessing fields of structure arrays.

```
m.y = y;
```

MATLAB adds a variable named `y` to the file.

Display all variables stored in the MAT-file, `myFile.mat`.

```
whos('-file','myFile.mat')
```

Name	Size	Bytes	Class	Attributes
x	20x20	3200	double	
y	15x15	1800	double	

### Load and Save Parts of Variables

Access specific elements of a MAT-file variable.

Open a new MAT-file, myFile2.mat.

```
m = matfile('myFile2.mat');
```

Save a 20-by-20 example array to part of a variable, y, in myFile2.mat. Specify the variable in the MAT-file using dot notation similar to accessing fields of structure arrays.

```
m.y(81:100,81:100) = magic(20);
```

MATLAB inserts the 20-by-20 array into the elements of y specified by the indices (81:100,81:100).

Read a subset of array y into a new workspace variable, z.

```
z = m.y(85:94,85:94);
```

MATLAB reads the 10-by-10 subarray specified by the indices (85:94,85:94) from the MAT-file into workspace variable z.

### Determine Size of Variables

Determine the size of a variable, and then calculate the average of each column.

Open the example MAT-file, stocks.mat.

```
filename = 'stocks.mat';
m = matfile(filename);
```

Determine the size of the variable, `stocks`, in `stocks.mat`.

```
[nrows,ncols] = size(m,'stocks');
```

Compute the average of each column of the variable `stocks`.

```
avgs = zeros(1,ncols);
for i = 1:ncols
 avgs(i) = mean(m.stocks(:,i));
end
```

## Enable Write Access to MAT-file

Enable write access to the MAT-file, `myFile.mat`, by setting `Writable` to `true` when you open the MAT-file.

```
filename = 'myFile.mat';
m = matfile(filename,'Writable',true);
```

Alternatively, set `Properties.Writable` in a separate step after you open the MAT-file.

```
m.Properties.Writable = true;
```

## Tips

- Using the `end` keyword as part of an index causes MATLAB to load the entire variable into memory. For very large variables, this load operation results in **Out of Memory** errors. Rather than using `end`, determine the extent of a variable, `myVar`, with the `size` method, such as:

```
sizeMyVar = size(m,'myVar')
```

## Limitations

- `matfile` does not support linear indexing. You must specify indices for all dimensions.
- `matfile` does not support indexing into:
  - Variables of tables
  - Cells of cell arrays

- Fields of structure arrays
- User-defined classes
- Sparse arrays
- You cannot assign complex values to an indexed portion of a real array.
- You cannot evaluate function handles using the `m` output. For example, if your MAT-file contains function handle `myfunc`, the syntax `m.myfunc()` attempts to index into the function handle, and does not invoke the function.
- Efficient partial loading and saving requires Version 7.3 MAT-files. To create a Version 7.3 MAT-file, call the `save` function with the `'-v7.3'` option. For example, to convert an existing MAT-file named `durer.mat` to Version 7.3, call:

```
load('durer.mat');
save('mycopy_durer.mat', '-v7.3');
```

## See Also

[load](#) | [save](#) | [size](#) | [whos](#)

## Concepts

- “Load Parts of Variables from MAT-Files”
- “Save Parts of Variables to MAT-Files”
- MAT-File Versions

# matlab.codetools.requiredFilesAndProducts

---

**Purpose** List dependencies of MATLAB program files

**Syntax**

```
fList = matlab.codetools.requiredFilesAndProducts(files)
[fList, pList] =
matlab.codetools.requiredFilesAndProducts(files)
[fList, pList] =
matlab.codetools.requiredFilesAndProducts(___,
 'toponly')
```

**Description** `fList = matlab.codetools.requiredFilesAndProducts(files)` returns a list of the MATLAB program files required to run the program files specified by `files`.

`[fList, pList] = matlab.codetools.requiredFilesAndProducts(files)` also returns a list of the MathWorks products required to run the program files specified by `files`.

`[fList, pList] = matlab.codetools.requiredFilesAndProducts(___, 'toponly')` indicates that for a file or product to be included in the output, it must be used directly by at least one file specified in `files`. The 'toponly' input string is case insensitive.

**Input Arguments** **files - List of files for analysis**

string or cell array of strings

List of files for analysis, specified as a string or cell array of strings. Each string is the name of a single MATLAB program file. For example, `files` is a list of MATLAB program files that you intend to provide to other users. The `matlab.codetools.requiredFilesAndProducts` function provides you with requirements information to pass along with your files.

To ensure an accurate dependency report, `files` and dependencies must be on the MATLAB path.



`matlab.codetools.requiredFilesAndProducts` does not return information about dependent files not on the path.

**Example:** `'myFile.m'` or `'C:\Program Files\MATLAB\R2014a\my_work\myFile.m'`

**Example:** `{'myFile.m','myOtherFile.m'}`

**Example:** `cellstr(ls('*.*'))`

## Output Arguments

### **fList** - List of user-authored MATLAB program files

cell array of strings

List of user-authored MATLAB program files required by `files`, returned as a cell array of strings. Each string indicates the full path of the required file. `fList` does not include built-in MATLAB files, since these files are installed with the products listed in `pList`.

### **pList** - List of MathWorks products

structure or array of structures

List of MathWorks products required by `files`, returned as a structure or array of structures. Each required product is described by name (`Name` field), version (`Version` field) and product number (`ProductNumber` field).

The `matlab.codetools.requiredFilesAndProducts` function is intended to provide you with information to pass on to consumers of your MATLAB program files. The version numbers indicate the version of the products you have installed when you execute the function. `Version` is not an indicator of backward compatibility.

## Examples

### **Identify Required Files and Products for MATLAB Toolbox Function**

Determine the required files and products for the `edge` function in the Image Processing Toolbox.

```
[fList,pList] = matlab.codetools.requiredFilesAndProducts('edge.m')
```

```
fList =

 {}

pList =

1x2 struct array with fields:

 Name
 Version
 ProductNumber
```

There are no required MATLAB files, but there are two required products.

List the required products.

```
{pList.Name}'
```

```
ans =

 'MATLAB'
 'Image Processing Toolbox'
```

## Identify Required Files and Products for Your MATLAB Program Files

In your current working folder, create a function in the file `getRandomNumber.m`.

```
function a = getRandomNumber
 rng('shuffle')
 a = rand;
end
```

Now, at the command line, determine the required files and products for `getRandomNumber.m`.

# matlab.codetools.requiredFilesAndProducts

---

```
[fList,pList] = matlab.codetools.requiredFilesAndProducts('getRandomNumber.m')
```

```
fList =
```

```
 'C:\work\getRandomNumber.m'
```

```
pList =
```

```
 Name: 'MATLAB'
 Version: '8.3'
 ProductNumber: 1
```

The only file required to run the `getRandomNumber` function is the function file itself. The only required MathWorks product is MATLAB.

In your current working folder, create a function in the file `displayNumber.m`.

```
function displayNumber
 a = getRandomNumber;
 disp(['Your number is ' num2str(a)]);
end
```

Now, at the command line, determine the required files and products for `displayNumber.m`.

```
[fList,pList] = matlab.codetools.requiredFilesAndProducts('displayNumber.m')
```

```
fList =
```

```
 'C:\work\displayNumber.m' 'C:\work\getRandomNumber.m'
```

```
pList =
```

```
 Name: 'MATLAB'
 Version: '8.3'
```

# matlab.codetools.requiredFilesAndProducts

---

```
ProductNumber: 1
```

In addition to the function file itself, the `displayNumber` function requires the `getRandomNumber.m` file. The only required MathWorks product is MATLAB.

## Identify Top-Level Dependencies Only

In your current working folder, create a handle class in the file `ExampleHandle.m`.

```
classdef ExampleHandle < handle
 % class content
end
```

In your current working folder, create a class in the file `AnotherExampleHandle.m` that inherits from `ExampleHandle`.

```
classdef AnotherExampleHandle < ExampleHandle
 % class content
end
```

In your current working folder, create a function in the file `getHandles.m` that instantiates `AnotherExampleHandle` objects.

```
function [h1,h2] = getHandles()
 h1 = AnotherExampleHandle;
 h2 = AnotherExampleHandle;
end
```

Now, at the command line, determine the required files for `getHandles.m`.

```
[fList,~] = matlab.codetools.requiredFilesAndProducts('getHandles.m');
fList'
```

```
ans =
```

```
'C:\work\AnotherExampleHandle.m'
```

# matlab.codetools.requiredFilesAndProducts

---

```
'C:\work\ExampleHandle.m'
'C:\work\getHandles.m'
```

Determine the required files that are directly required for `getHandles.m`.

```
[fList,~] = matlab.codetools.requiredFilesAndProducts('getHandles.m',
fList =
```

```
'C:\work\AnotherExampleHandle.m' 'C:\work\getHandles.m'
```

Although `AnotherExampleHandle.m` requires `ExampleHandle.m`, that file is not a direct requirement for `getHandles.m`.

## Concepts

- “Identify Program Dependencies”

# matlab.io.MatFile

---

**Purpose** Load and save parts of variables in MAT-files

**Description** The `matfile` function constructs a `matlab.io.MatFile` object that corresponds to a MAT-File, such as

```
matObj = matfile('myFile.mat')
```

Access variables in the MAT-file as properties of `matObj`, with dot notation similar to accessing fields of structs. The syntax for loading and saving part of variable `varName` in the MAT-file corresponding to `matObj` is:

```
loadedData = matObj.varName(indices); % Load into workspace
matObj.varName(indices) = dataToSave; % Save to file
```

When indexing, specify indices for all dimensions. Indices can be a single value, an equally spaced range of increasing values, or a colon (:), such as

```
matObj.varName(100:500, 200:600)
matObj.varName(:, 501:1000)
matObj.varName(1:2:1000, 80)
```

## Limitations

- Using the `end` keyword as part of an index causes MATLAB to load the entire variable into memory. For very large variables, this load operation results in Out of Memory errors. Rather than using `end`, determine the extent of a variable with the `size` method, such as:

```
sizeMyVar = size(matObj, 'myVar')
```

- `matfile` does not support linear indexing. You must specify indices for all dimensions.
- `matfile` does not support indexing into:
  - Cells of cell arrays
  - Fields of structs

- User-defined classes
- Sparse arrays
- You cannot assign complex values to an indexed portion of a real array.
- You cannot evaluate function handles using a `MatFile` object. For example, if your MAT-file contains function handle `myfunc`, the syntax `matObj.myfunc()` attempts to index into the function handle, and does not invoke the function.

## Construction

`matObj = matfile(filename)` constructs a `matlab.io.MatFile` object that can load or save parts of variables in MAT-file `filename`. MATLAB does not load any data from the file into memory when creating the object.

`matObj = matfile(filename, 'Writable', isWritable)` enables or disables write access to the file for object `matObj`. Possible values for `isWritable` are logical true (1) or false (0).

## Input Arguments

### **filename**

String enclosed in single quotation marks that specifies the name of a MAT-file.

`filename` can include a full or partial path, otherwise `matfile` searches for the file along the MATLAB search path. If `filename` does not include an extension, `matfile` appends `.mat`.

If the file does not exist, `matfile` creates a Version 7.3 MAT-file on the first assignment to a variable.

`matfile` only supports partial loading and saving for MAT-files in Version 7.3 format (described in *MAT-File Versions*). If you index into a variable in a Version 7 (the current default) or earlier MAT-file, MATLAB warns and temporarily loads the entire contents of the variable.

### **'Writable'**

Parameter to use with the `isWritable` argument.

## **isWritable**

Logical value that specifies whether to allow saving to the file.  
Possible values:

- |                           |                                                                                                       |
|---------------------------|-------------------------------------------------------------------------------------------------------|
| <code>true</code><br>(1)  | Enable saving. If the file is read only, change the system permissions with <code>fileattrib</code> . |
| <code>false</code><br>(0) | Disable saving with <code>matfile</code> . MATLAB does not change the system permissions.             |

**Default:** `true` for new files, `false` for existing files

## **Properties**

### **Properties.Source**

String that contains the fully qualified path to the file. Read only.

### **Properties.Writable**

Logical value that specifies whether to allow saving to the file.  
Possible values:

- |                           |                                                                                                       |
|---------------------------|-------------------------------------------------------------------------------------------------------|
| <code>true</code><br>(1)  | Enable saving. If the file is read only, change the system permissions with <code>fileattrib</code> . |
| <code>false</code><br>(0) | Disable saving with <code>matfile</code> . MATLAB does not change the system permissions.             |

**Default:** `true` for new files, `false` for existing files

## **Methods**

<code>size</code>	Array dimensions
<code>who</code>	Names of variables in MAT-file
<code>whos</code>	Names, sizes, and types of variables in MAT-file



You cannot access help for these methods using the `help` command. Find help on the methods from the command line using the `doc` command, such as `doc matlab.io.MatFile/size`.

## Copy Semantics

Handle. To learn how handle classes affect copy operations, see Copying Objects in the MATLAB documentation.

## Examples

Create `myFile.mat` in a temporary folder and save data to part of variable `savedVar`:

```
filename = fullfile(tempdir,'myFile.mat');
matObj = matfile(filename);
matObj.savedVar(81:100,81:100) = magic(20);
```

Load part of the data into variable `loadVar`:

```
loadVar = matObj.savedVar(85:94,85:94);
```

---

Load or save an entire variable by omitting the indices. For example, load variable `topo` from `topography.mat`:

```
filename = 'topography.mat';
matObj = matfile(filename);
topo = matObj.topo;
```

---

Determine the dimensions of a variable, and process one part of the variable at a time. In this case, calculate and store the average of each column of variable `stocks` in the example file `stocks.mat`:

```
filename = 'stocks.mat';
matObj = matfile(filename);
[nrows, ncols] = size(matObj,'stocks');

avgs = zeros(1,ncols);
for idx = 1:ncols
```

# matlab.io.MatFile

---

```
 avgs(idx) = mean(matObj.stocks(:,idx));
end
```

---

By default, `matfile` only supports loading data from existing files. To enable saving, set `Writable` to `true` either during construction of the object,

```
filename = 'myFile.mat';
matObj = matfile(filename, 'Writable', true);
```

or in a separate step, by setting `Properties.Writable`:

```
filename = 'myFile.mat';
matObj = matfile(filename);
matObj.Properties.Writable = true;
```

## See Also

[load](#) | [save](#) | [size](#) | [whos](#)

**Purpose** Close FITS file

**Syntax** `closeFile(fptr)`

**Description** `closeFile(fptr)` closes an open FITS file.

This function corresponds to the `fits_close_file` (`ffclos`) function in the CFITSIO library C API.

**Examples**

```
import matlab.io.*
fptr = fits.openFile('tst0012.fits','READONLY');
fits.closeFile(fptr);
```

**See Also** [createFile](#) | [openFile](#)

# matlab.io.fits.createFile

---

**Purpose** Create FITS file

**Syntax** `fptr = createFile(filename)`

**Description** `fptr = createFile(filename)` creates a FITS file. An error will be returned if the specified file already exists, unless the filename is prefixed with an exclamation point (!). In that case CFITSIO will overwrite (delete) any existing file with the same name.

This function corresponds to the `fits_create_file` (`ffinit`) function in the CFITSIO library C API.

**Examples** Create a new FITS file, overwriting any existing file by the same name.

```
import matlab.io.*
fptr = fits.createFile('myfile.fits');
fits.createImg(fptr,'uint8',[256 512]);
fits.closeFile(fptr);
fitsdisp('myfile.fits');
```

**See Also** [openFile](#) | [closeFile](#) | [createImg](#) | [createTbl](#)

**Purpose** Delete FITS file

**Syntax** deleteFile(fptr)

**Description** deleteFile(fptr) closes and deletes an open FITS file. This can be useful if a FITS file cannot be properly closed.

This function corresponds to the fits\_delete\_file (ffdel) function in the CFITSIO library C API.

**Examples**

```
import matlab.io.*
srcFile = fullfile(matlabroot,'toolbox','matlab','demos','tst0012.fits');
copyfile(srcFile,'myfile.fits');
fileattrib('myfile.fits','+w');
fptr = fits.openFile('myfile.fits','readwrite');
fits.deleteFile(fptr);
fptrs = fits.getOpenFiles()
```

**See Also** createFile | closeFile

# matlab.io.fits.fileName

---

**Purpose** Name of FITS file

**Syntax** name = fileName(fpPtr)

**Description** name = fileName(fpPtr) returns the name of the FITS file associated with the file handle.

This function corresponds to the fits\_file\_name (ffflnm) function in the CFITSIO library C API.

**Examples**

```
import matlab.io.*
fpPtr = fits.openFile('tst0012.fits','READONLY');
name = fits.fileName(fpPtr);
fits.closeFile(fpPtr);
```

**See Also** createFile | openFile

**Purpose** I/O mode of FITS file

**Syntax** `mode = fileMode(fptr)`

**Description** `mode = fileMode(fptr)` returns the I/O mode of the opened FITS file. Possible values returned for mode are 'READONLY' or 'READWRITE'.  
This function corresponds to the `fits_file_mode (ffflmd)` function in the CFITSIO library C API.

**Examples**

```
import matlab.io.*
fptr = fits.openFile('tst0012.fits');
mode = fits.fileMode(fptr);
fits.closeFile(fptr);
```

**See Also** `createFile` | `openFile`

# matlab.io.fits.openFile

---

**Purpose** Open FITS file

**Syntax**  
fptr = openFile(filename)  
fptr = openFile(filename,mode)

**Description** fptr = openFile(filename) opens an existing FITS file in read-only mode and returns a file pointer, fptr, which references the primary array (first header data unit, or "HDU").

fptr = openFile(filename,mode) opens an existing FITS file according to the mode, which describes the type of access. mode may be either 'READONLY' or 'READWRITE'.

This function corresponds to the fits\_open\_file (ffopen) function in the CFITSIO library C API.

**Examples** Open a file in read-only mode and read image data from the primary array.

```
import matlab.io.*
fptr = fits.openFile('tst0012.fits');
imagedata = fits.readImg(fptr);
fits.closeFile(fptr);
```

---

Open a file in read-write mode and add a comment to the primary array.

```
import matlab.io.*
srcFile = fullfile(matlabroot,'toolbox','matlab','demos','tst0012.fits');
copyfile(srcFile,'myfile.fits');
fileattrib('myfile.fits','+w');
fptr = fits.openFile('myfile.fits','readwrite');
fits.writeComment(fptr,'This is just a comment.');
```

**See Also** createFile | closeFile



**Purpose** Create FITS image

**Syntax** `createImg(fptr,bitpix,naxes)`

**Description** `createImg(fptr,bitpix,naxes)` creates a new primary image or image extension with a specified datatype `bitpix` and size `naxes`. If the FITS file is currently empty then a primary array is created, otherwise a new image extension is appended to the file.

The first two elements of `naxes` correspond to the NAXIS2 and NAXIS1 keywords, while any additional elements correspond to the NAXIS3, NAXIS4 ... NAXISn keywords.

The datatype `bitpix` may be given as either a CFITSIO name or as the corresponding MATLAB datatype.

'byte_img'	'uint8'
'short_img'	'int16'
'long_img'	'int32'
'longlong_img'	'int64'
'float_img'	'single'
'double_img'	'double'

This function corresponds to the `fits_create_img11` (`ffcrim11`) function in the CFITSIO library C API.

## Examples

Create two images in a new FITS file. There are 100 rows (NAXIS2 keyword) and 200 columns (NAXIS1 keyword) in the first image, and 256 rows (NAXIS2 keyword), 512 columns (NAXIS1 keyword), and 3 planes (NAXIS3 keyword) in the second image.

```
import matlab.io.*
fptr = fits.createFile('myfile.fits');
fits.createImg(fptr,'int16',[100 200]);
fits.createImg(fptr,'byte_img',[256 512 3]);
fits.closeFile(fptr);
```

# matlab.io.fits.createImg

---

```
fitsdisp('myfile.fits');
```

## See Also

[insertImg](#) | [createTbl](#) | [readImg](#) | [writeImg](#) | [setCompressionType](#)

**Purpose**

Size of image

**Syntax**

```
imagesize = getImgSize(fptr)
```

**Description**

`imagesize = getImgSize(fptr)` returns the number of rows and columns of an image. This function corresponds to the `fits_get_img_size` (`ffgisz`) function in the CFITSIO library C API.

**Examples**

```
import matlab.io.*;
fptr = fits.openFile('tst0012.fits');
hdus = [1 3 4];
for j = hdus;
 htype = fits.movAbsHDU(fptr,j);
 sz = fits.getImgSize(fptr);
 fprintf('HDU %d: "%s", [' , j, htype);
 for k = 1:numel(sz)
 fprintf(' %d ', sz(k));
 end
 fprintf(']\n');
end
fits.closeFile(fptr);
```

**See Also**

[createImg](#) | [getImgType](#)

# matlab.io.fits.getImgType

---

**Purpose** Data type of image

**Syntax** `datatype = getImgType(fptr)`

**Description** `datatype = getImgType(fptr)` gets the data type of an image. `datatype` can be one of the following strings:

```
'BYTE_IMG'
'SHORT_IMG'
'LONG_IMG'
'LONGLONG_IMG'
'FLOAT_IMG'
'DOUBLE_IMG'
```

This function corresponds to the `fits_get_img_type` (`ffgidt`) function in the CFITSIO library C API.

## Examples

```
fptr = fits.openFile('tst0012.fits');
hdus = [1 3 4];
for j = hdus;
 htype = fits.movAbsHDU(fptr,j);
 dtype = fits.getImgType(fptr);
 fprintf('HDU %d: "%s", "%s"\n', j, htype, dtype);
end
fits.closeFile(fptr);
```

**See Also** `getImgSize`

**Purpose** Insert FITS image after current image

**Syntax** `insertImage(fptr,bitpix,naxes)`

**Description** `insertImage(fptr,bitpix,naxes)` inserts a new image extension immediately following the current HDU. If the file has just been created, a new primary array is inserted at the beginning of the file. Any following extensions in the file will be shifted down to make room for the new extension. If the current HDU is the last HDU in the file, then the new image extension will be appended to the end of the file.

This function corresponds to the `fits_insert_img11` (`ffiimg11`) function in the CFITSIO library C API.

**Examples** Create a 150x300 image between the 1st and 2nd images in a FITS file.

```
import matlab.io.*
fptr = fits.createFile('myfile.fits');
fits.createImg(fptr,'byte_img',[100 200]);
fits.createImg(fptr,'byte_img',[200 400]);
fits.movAbsHDU(fptr,1);
fits.insertImg(fptr,'byte_img',[150 300]);
fits.closeFile(fptr);
fitsdisp('myfile.fits','mode','min');
```

**See Also** `createImg`

# matlab.io.fits.readImg

---

**Purpose** Read image data

**Syntax**

```
imgdata = readImg(fpPtr)
imgdata = readImg(fpPtr,fpixel,lpixel)
imgdata = readImg(fpPtr,fpixel,lpixel,inc)
```

**Description** `imgdata = readImg(fpPtr)` reads the entire current image. The number of rows in `imgdata` will correspond to the value of the NAXIS2 keyword, while the number of columns will correspond to the value of the NAXIS1 keyword. Any further dimensions of `imgdata` will correspond to NAXIS3, NAXIS4, and so on.

`imgdata = readImg(fpPtr,fpixel,lpixel)` reads the subimage defined by pixel coordinates `fpixel` and `lpixel`. The `fpixel` argument is the coordinate of the first pixel and `lpixel` is the coordinate of the last pixel. `fpixel` and `lpixel` are one-based.

`imgdata = readImg(fpPtr,fpixel,lpixel,inc)` reads the subimage defined by `fpixel`, `lpixel`, and `inc`. The `inc` argument denotes the inter- element spacing along each extent.

This function corresponds to the `fits_read_subset (ffgsV)` function in the CFITSIO library C API.

**Examples** Read an entire image.

```
import matlab.io.*
fpPtr = fits.openFile('tst0012.fits');
data = fits.readImg(fpPtr);
fits.closeFile(fpPtr);
```

---

Read a 70x80 image subset.

```
import matlab.io.*
fpPtr = fits.openFile('tst0012.fits');
img = fits.readImg(fpPtr,[11 11],[80 90]);
fits.closeFile(fpPtr);
```

**See Also**     `createImg` | `writeImg`

# matlab.io.fits.setBscale

---

**Purpose**            Reset image scaling

**Syntax**            `setBscale(fptr,BSCALE,BZERO)`

**Description**        `setBscale(fptr,BSCALE,BZERO)` resets the scaling factors in the primary array or image extension according to the equation

`output = (FITS array) * BSCALE + BZERO`

The inverse formula is used when writing data values to the FITS file.

This only affects the automatic scaling performed when the data elements are read. It does not change the BSCALE and BZERO keyword values.

**Examples**

```
import matlab.io.*
fptr = fits.openFile('tst0012.fits');
fits.setBscale(fptr,2.0,0.5);
data = fits.readImg(fptr);
fits.closeFile(fptr);
```

**See Also**            `readImg`



**Purpose** Write to FITS image

**Syntax** `writeImg(fptr,data)`  
`writeImg(fptr,data,fpixel)`

**Description** `writeImg(fptr,data)` writes an entire image to the FITS data array. The number of rows and columns in `data` must equal the values of the `NAXIS2` and `NAXIS1` keywords, respectively. Any further extents must correspond to the `NAXIS3`, `NAXIS4` ... `NAXISn` keywords respectively.

`writeImg(fptr,data,fpixel)` writes a subset of an image to the FITS data array. `fpixel` gives the coordinate of the first pixel in the image region.

This function corresponds to the `fits_write_subset` (`ffpss`) function in the CFITSIO library C API.

**Examples**

```
import matlab.io.*
fptr = fits.createFile('myfile.fits');
fits.createImg(fptr,'long_img',[256 512]);
data = reshape(1:256*512,[256 512]);
data = int32(data);
fits.writeImg(fptr,data);
fits.closeFile(fptr);
```

---

Create an 80x40 `uint8` image and set all but the outermost pixels to 1.

```
import matlab.io.*
fptr = fits.createFile('myfile.fits');
fits.createImg(fptr,'uint8',[80 40]);
data = ones(78,38);
fits.writeImg(fptr,data,[1 1]);
fits.closeFile(fptr);
```

**See Also** `readImg` | `createImg`

# matlab.io.fits.deleteKey

---

**Purpose** Delete key by name

**Syntax** deleteKey(fpPtr,keyname)

**Description** deleteKey(fpPtr,keyname) deletes a keyword by name.  
This function corresponds to the fits\_delete\_key (ffdrec) function in the CFITSIO library C API.

**Examples**

```
import matlab.io.*
srcFile = fullfile(matlabroot,'toolbox','matlab','demos','tst0012.fits');
copyfile(srcFile,'myfile.fits');
fileattrib('myfile.fits','+w');
fprintf('Before key deletion...\n');
fitsdisp('myfile.fits','index',1);
fpPtr = fits.openFile('myfile.fits','readwrite');
fits.deleteKey(fpPtr,'DATE');
fits.closeFile(fpPtr);
fprintf('\n\n\nAfter key deletion...\n');
fitsdisp('myfile.fits','index',1);
```

**See Also** deleteRecord | writeKey

**Purpose** Delete key by record number

**Syntax** `deleteRecord(fpPtr,keynum)`

**Description** `deleteRecord(fpPtr,keynum)` deletes a keyword by record number. This function corresponds to the `fits_delete_record` (`ffdrec`) function in the CFITSIO library C API.

**Examples** Delete the 18th keyword ("ORIGIN") in a primary array.

```
import matlab.io.*
srcFile = fullfile(matlabroot,'toolbox','matlab','demos','tst0012.fits');
copyfile(srcFile,'myfile.fits');
fileattrib('myfile.fits','+w');
fpPtr = fits.openFile('myfile.fits','readwrite');
card = fits.readRecord(fpPtr,18);
fits.deleteRecord(fpPtr,18);
fits.closeFile(fpPtr);
```

**See Also** `readRecord` | `deleteKey`

# matlab.io.fits.getHdrSpace

---

**Purpose**            Number of keywords in header

**Syntax**            `[nkeys,morekeys] = fits.getHdrSpace(fpPtr)`

**Description**        `[nkeys,morekeys] = fits.getHdrSpace(fpPtr)` returns the number of existing keywords (not counting the END keyword) and the amount of space currently available for more keywords. It returns `morekeys = -1` if the header has not yet been closed. Note that the CFITSIO library will dynamically add space if required when writing new keywords to a header so in practice there is no limit to the number of keywords that can be added to a header.

This function corresponds to the `fits_get_hdrspace (ffghsp)` function in the CFITSIO library C API.

**Examples**

```
import matlab.io.*
fpPtr = fits.openFile('tst0012.fits');
[nkeys,morekeys] = fits.getHdrSpace(fpPtr);
fits.closeFile(fpPtr);
```

**Purpose** Header record of keyword

**Syntax** `card = readCard(fpPtr,keyname)`

**Description** `card = readCard(fpPtr,keyname)` returns the entire 80-character header record of the keyword, with any trailing blank characters stripped off.

This function corresponds to the `fits_read_card` (`ffgcrd`) function in the CFITSIO library C API.

**Examples**

```
import matlab.io.*
fpPtr = fits.openFile('tst0012.fits');
n = fits.getNumHDUs(fpPtr);
for j = 1:n
 fits.movAbsHDU(fpPtr,j);
 card = fits.readCard(fpPtr,'NAXIS');
 fprintf('HDU %d: '%s'\n', j, card);
end
fits.closeFile(fpPtr);
```

**See Also** [readRecord](#) | [readKey](#)

# matlab.io.fits.readKey

---

**Purpose** Keyword

**Syntax** [value,comment] = readKey(fpPtr,keyname)

**Description** [value,comment] = readKey(fpPtr,keyname) returns the specified key and comment. value is returned as a string.

This function corresponds to the fits\_read\_key\_str (ffgkys) function in the CFITSIO library C API.

## Examples

```
import matlab.io.*
fpPtr = fits.openFile('tst0012.fits');
n = fits.getNumHDUs(fpPtr);
for j = 1:n
 fits.movAbsHDU(fpPtr,j);
 [key,comment] = fits.readKey(fpPtr,'NAXIS');
 fprintf('HDU %d: NAXIS %s, "%s"\n', j, key, comment);
end
fits.closeFile(fpPtr);
```

**See Also** readKeyCmplx | readKeyDb1 | readKeyLongLong

**Purpose** Keyword as complex scalar value

**Syntax** [value,comment] = readKeyCmplx(fptr,keyname)

**Description** [value,comment] = readKeyCmplx(fptr,keyname) returns the specified key and comment. value is returned as a double precision complex scalar value.

This function corresponds to the fits\_read\_key\_dblcmp" (ffgkym) function in the CFITSIO library C API.

**See Also** readKey | readKeyDb1 | readKeyLongLong

# matlab.io.fits.readKeyDbl

---

**Purpose** Keyword as double precision value

**Syntax** [value,comment] = readKeyDbl(fpPtr,keyname)

**Description** [value,comment] = readKeyDbl(fpPtr,keyname) returns the specified key and comment.

This function corresponds to the fits\_read\_key\_dbl (ffgkyd) function in the CFITSIO library C API.

## Examples

```
import matlab.io.*
fpPtr = fits.openFile('tst0012.fits');
n = fits.getNumHDUs(fpPtr);
for j = 1:n
 fits.movAbsHDU(fpPtr,j);
 [key,comment] = fits.readKeyDbl(fpPtr,'NAXIS');
 fprintf('HDU %d: NAXIS %s, "%s"\n', j, key, comment);
end
fits.closeFile(fpPtr);
```

**See Also** readKey | readKeyCmplx | readKeyLongLong



**Purpose** Keyword as int64

**Syntax** [value,comment] = readKeyLongLong(fpPtr,keyname)

**Description** [value,comment] = readKeyLongLong(fpPtr,keyname) returns the specified key and comment. value is returned an int64 scalar value. This function corresponds to the fits\_read\_key\_lnglng (ffgkyjj) function in the CFITSIO library C API.

**Examples**

```
import matlab.io.*
fpPtr = fits.openFile('tst0012.fits');
n = fits.getNumHDUs(fpPtr);
for j = 1:n
 fits.movAbsHDU(fpPtr,j);
 [key,comment] = fits.readKeyLongLong(fpPtr,'NAXIS');
 fprintf('HDU %d: NAXIS %d, "%s"\n', j, key, comment);
end
fits.closeFile(fpPtr);
```

**See Also** readKey | readKeyCmplx | readKeyDb1

# matlab.io.fits.readKeyLongStr

---

**Purpose** Long string value

**Syntax** [value,comment] = readKeyLongStr(fptr,keyname)

**Description** [value,comment] = readKeyLongStr(fptr,keyname) returns the specified long string value and comment.

This function corresponds to the fits\_read\_key\_longstr (ffgk1s) function in the CFITSIO library C API.

**Examples**

```
import matlab.io.*
idata = repmat(char(97:106),1,10);
fptr = fits.createFile('myfile.fits');
fits.createImg(fptr,'byte_img',[100 200]);
fits.writeKey(fptr,'mykey',idata);
odata1 = fits.readKey(fptr,'mykey');
odata2 = fits.readKeyLongStr(fptr,'mykey');
fits.closeFile(fptr);
```

**See Also** readKey

**Purpose** Physical units string from keyword

**Syntax** `units = readKeyUnit(fpPtr,keyname)`

**Description** `units = readKeyUnit(fpPtr,keyname)` returns the physical units string from an existing keyword. If no units are defined, `units` is returned as an empty string.

This function corresponds to the `fits_read_key_unit` (ffgunt) function in the CFITSIO library C API.

**Examples**

```
import matlab.io.*
fpPtr = fits.createFile('myfile.fits');
fits.createImg(fpPtr,'long_img',[10 20]);
fits.writeKey(fpPtr,'VELOCITY',12.3,'orbital speed');
fits.writeKeyUnit(fpPtr,'VELOCITY','km/s');
units = fits.readKeyUnit(fpPtr,'VELOCITY');
fits.closeFile(fpPtr);
```

**See Also** `readKey` | `writeKeyUnit`

# matlab.io.fits.readRecord

---

**Purpose** Header record specified by number

**Syntax** `card = readRecord(fpPtr,keynum)`

**Description** `card = readRecord(fpPtr,keynum)` returns the entire 80-character header record identified by the numeric `keynum`. Trailing blanks are truncated.

This function corresponds to the `fits_read_record` (`ffgrec`) function in the CFITSIO library C API.

**Examples** Read the second record in each HDU.

```
import matlab.io.*
fpPtr = fits.openFile('tst0012.fits');
n = fits.getHdrSpace(fpPtr);
for j = 1:n
 card = fits.readRecord(fpPtr,j);
 fprintf('record %d: "%s"\n', j, card);
end
fits.closeFile(fpPtr);
```

**See Also** `deleteRecord` | `readKey` | `readCard`

**Purpose** Write or append COMMENT keyword to CHU

**Syntax** `writeComment(fpPtr,comment)`

**Description** `writeComment(fpPtr,comment)` writes (appends) a COMMENT keyword to the CHU. The comment string will be continued over multiple keywords if it is longer than 70 characters.

This function corresponds to the `fits_write_comment` (`ffpcom`) function in the CFITSIO library C API.

**Examples**

```
import matlab.io.*
fpPtr = fits.createFile('myfile.fits');
fits.createImg(fpPtr,'byte_img',[100 200]);
fits.writeComment(fpPtr,'this is a comment');
fits.writeComment(fpPtr,'this is another comment');
fits.closeFile(fpPtr);
fitsdisp('myfile.fits','mode','full');
```

**See Also** [writeHistory](#) | [writeDate](#)

# matlab.io.fits.writeDate

---

**Purpose** Write DATE keyword to CHU

**Syntax** writeDate(FPTR)

**Description** writeDate(FPTR) writes the DATE keyword to the CHU.

This function corresponds to the `fits_write_date` (`ffpdat`) function in the CFITSIO library C API.

**Examples**

```
import matlab.io.*
fptr = fits.createFile('myfile.fits');
fits.createImg(fptr,'byte_img',[100 200]);
fits.writeDate(fptr);
fits.closeFile(fptr);
fitsdisp('myfile.fits','mode','full');
```

**See Also** writeComment | writeHistory

**Purpose**

Update or add new keyword into current HDU

**Syntax**

```
writeKey(fpPtr, keyname, value, comment)
writeKey(fpPtr, keyname, value, comment, decimals)
```

**Description**

`writeKey(fpPtr, keyname, value, comment)` adds a new record in the current HDU, or updates it if it already exists. `comment` is optional.

`writeKey(fpPtr, keyname, value, comment, decimals)` adds a new floating point keyword in the current HDU, or updates it if it already exists. You must use this syntax to write a keyword with imaginary components. `decimals` is ignored otherwise.

If a character `value` exceeds 68 characters in length, the LONGWARN convention is automatically employed.

This function corresponds to the `fits_write_key` (`ffpky`) and `fits_update_key` (`ffuky`) family of functions in the CFITSIO library C API.

**Examples**

```
import matlab.io.*
fpPtr = fits.createFile('myfile.fits');
fits.createImg(fpPtr, 'byte_img', [100 200]);
fits.writeKey(fpPtr, 'mykey1', 'a char value', 'with a comment');
fits.writeKey(fpPtr, 'mykey2', int32(1));
fits.writeKey(fpPtr, 'mykey3', 5+7*j, 'with another comment');
fits.writeKey(fpPtr, 'mykey4', 4/3, 'with yet another comment', 2);
fits.closeFile(fpPtr);
fitsdisp('myfile.fits', 'mode', 'full');
```

**See Also**

[readKey](#) | [deleteKey](#) | [readRecord](#)

# matlab.io.fits.writeKeyUnit

---

**Purpose** Write physical units string

**Syntax** writeKeyUnit(fpPtr,keyname,unit)

**Description** writeKeyUnit(fpPtr,keyname,unit) writes a physical units string into an existing keyword.

This function corresponds to the fits\_write\_key\_unit (ffpunit) function in the CFITSIO library C API.

**Examples**

```
import matlab.io.*
fpPtr = fits.createFile('myFitsFile.fits');
fits.createImg(fpPtr,'long_img',[10 20]);
fits.writeKey(fpPtr,'VELOCITY',12.3,'orbital speed');
fits.writeKeyUnit(fpPtr,'VELOCITY','km/s');
fits.closeFile(fpPtr);
```

**See Also** readKeyUnit



**Purpose** Write or append HISTORY keyword to CHU

**Syntax** writeHistory(fpPtr,history)

**Description** writeHistory(fpPtr,history) writes (appends) a HISTORY keyword to the CHU. The history string is continued over multiple keywords if it is longer than 70 characters.

This function corresponds to the fits\_write\_history (ffphis) function in the CFITSIO library C API.

**Examples**

```
import matlab.io.*
fpPtr = fits.createFile('myfile.fits');
fits.createImg(fpPtr,'byte_img',[100 200]);
fits.writeHistory(fpPtr,'this is a history keyword');
fits.closeFile(fpPtr);
fitsdisp('myfile.fits','mode','full');
```

**See Also** writeComment | writeDate

# matlab.io.fits.copyHDU

---

**Purpose** Copy current HDU from one file to another

**Syntax** `copyHDU(infptr,outfptr)`

**Description** `copyHDU(infptr,outfptr)` copies the current HDU from the FITS file associated with `infptr` and appends it to the end of the FITS file associated with `outfptr`.

This function corresponds to the `fits_copy_hdu` (`ffcopy`) function in the CFITSIO library C API.

**Examples** Copy the first, third, and fifth HDUs from one file to another.

```
import matlab.io.*
infptr = fits.openFile('tst0012.fits');
outfptr = fits.createFile('myfile.fits');
fits.copyHDU(infptr,outfptr);
fits.movAbsHDU(infptr,3);
fits.copyHDU(infptr,outfptr);
fits.movAbsHDU(infptr,5);
fits.copyHDU(infptr,outfptr);
fits.closeFile(infptr);
fits.closeFile(outfptr);
fitsdisp('tst0012.fits','mode','min','index',[1 3 5]);
fitsdisp('myfile.fits','mode','min');
```

**See Also** `deleteHDU`

**Purpose** Delete current HDU in FITS file

**Syntax** HDU\_TYPE = deleteHDU(fptr)

**Description** HDU\_TYPE = deleteHDU(fptr) deletes the current HDU in the FITS file. Any following HDUs will be shifted forward in the file, filling the gap created by the deleted HDU. In the case of deleting the primary array (the first HDU in the file) then the current primary array will be replaced by a null primary array containing the minimum set of required keywords and no data. If there are more HDUs in the file following the HDU being deleted, then the current HDU will be redefined to point to the following HDU. If there are no following HDUs then the current HDU will be redefined to point to the previous HDU. HDU\_TYPE returns the type of the new current HDU.

This function corresponds to the fits\_delete\_hdu (ffdhdu) function in the CFITSIO library C API.

**Examples** Delete the second HDU in a FITS file.

```
import matlab.io.*
srcFile = fullfile(matlabroot,'toolbox','matlab','demos','tst0012.fits');
copyfile(srcFile,'myfile.fits');
fileattrib('myfile.fits','+w');
fitsdisp('myfile.fits','mode','min');
fptr = fits.openFile('myfile.fits','readwrite');
fits.movAbsHDU(fptr,2);
new_current_hdu = fits.deleteHDU(fptr);
fits.closeFile(fptr);
fitsdisp('myfile.fits','mode','min');
```

**See Also** copyHDU

# matlab.io.fits.getHDUnum

---

**Purpose**            Number of current HDU in FITS file

**Syntax**            `N = getHDUnum(fptr)`

**Description**      `N = getHDUnum(fptr)` returns the number of the current HDU in the FITS file. The primary array has HDU number 1.

This function corresponds to the `fits_get_hdu_num` (`ffghdn`) function in the CFITSIO library C API.

**Examples**

```
import matlab.io.*
fptr = fits.openFile('tst0012.fits');
n = fits.getHDUnum(fptr);
fits.closeFile(fptr);
```

**See Also**            `getNumHDUs` | `getHDUtype`

**Purpose** Type of current HDU

**Syntax** `htype = getHDUtype(fptr)`

**Description** `htype = getHDUtype(fptr)` returns the type of the current HDU in the FITS file. The possible values for `htype` are:

```
'IMAGE_HDU'
'ASCII_TBL'
'BINARY_TBL'
```

This function corresponds to the `fits_get_hdu_type` (`ffghdt`) function in the CFITSIO library C API.

**Examples**

```
import matlab.io.*
fptr = fits.openFile('tst0012.fits');
n = fits.getNumHDUs(fptr);
for j = 1:n
 fits.getHDUtype(fptr);
end
fits.closeFile(fptr);
```

**See Also** `getHDUnum`

# matlab.io.fits.getNumHDUs

---

**Purpose** Total number of HDUs in FITS file

**Syntax** N = getNumHDUs(fpPtr)

**Description** N = getNumHDUs(fpPtr) returns the number of completely defined HDUs in a FITS file. If a new HDU has just been added to the FITS file, then that last HDU will only be counted if it has been closed, or if data has been written to the HDU. The current HDU remains unchanged by this routine.

This function corresponds to the fits\_get\_num\_hdus (ffthdu) function in the CFITSIO library C API.

**Examples**

```
import matlab.io.*
fpPtr = fits.openFile('tst0012.fits');
n = fits.getNumHDUs(fpPtr);
fits.closeFile(fpPtr);
```

**See Also** getHDUenum

**Purpose** Move to absolute HDU number

**Syntax** `htype = fits.movAbsHDU(fptr,HDUNUM)`

**Description** `htype = fits.movAbsHDU(fptr,HDUNUM)` moves to a specified absolute HDU number (starting with 1 for the primary array) in the FITS file. The possible values for `htype` are:

```
'IMAGE_HDU'
'ASCII_TBL'
'BINARY_TBL'
```

This function corresponds to the `fits_move_abs_hdu` function in the CFITSIO library C API.

## Examples

```
import matlab.io.*
fptr = fits.openFile('tst0012.fits');
n = fits.getNumHDUs(fptr);
for j = 1:n
 htype = fits.movAbsHDU(fptr,j);
 fprintf('HDU %d: "%s"\n',j,htype);
end
fits.closeFile(fptr);
```

## See Also

`getNumHDUs` | `movRelHDU` | `movNamHDU`

# matlab.io.fits.movNamHDU

---

**Purpose** Move to first HDU having specific type and keyword values

**Syntax** `movNamHDU(fptr,hdutype,EXTNAME,EXTVER)`

**Description** `movNamHDU(fptr,hdutype,EXTNAME,EXTVER)` moves to the first HDU which has the specified extension type and EXTNAME and EXTVER keyword values (or HDUNAME and HDUVER keywords).

The `hdutype` parameter may have a value of:

```
'IMAGE_HDU'
'ASCII_TBL'
'BINARY_TBL'
'ANY_HDU'
```

If `hdutype` is 'ANY\_HDU', only the EXTNAME and EXTVER values are used to locate the correct extension. If the input value of EXTVER is 0, then the EXTVER keyword is ignored and the first HDU with a matching EXTNAME (or HDUNAME) keyword will be found.

This function corresponds to the `fits_movnam_hdu` (`ffmnhd`) function in the CFITSIO library C API.

## Examples

```
import matlab.io.*
fptr = fits.openFile('tst0012.fits');
fits.movNamHDU(fptr,'IMAGE_HDU','quality',1);
fits.closeFile(fptr);
```

**See Also** `movAbsHDU` | `movRelHDU`



**Purpose** Move relative number of HDUs from current HDU

**Syntax** `htype = moveRelHDU(fpPtr,nmove)`

**Description** `htype = moveRelHDU(fpPtr,nmove)` moves a relative number of HDUs forward or backward from the current HDU and returns the HDU type, `htype`, of the resulting HDU. The possible values for `htype` are:

```
'IMAGE_HDU'
'ASCII_TBL'
'BINARY_TBL'
```

This function corresponds to the `fits_movrel_hdu` (`ffmrhd`) function in the CFITSIO library C API.

**Examples** Move through each HDU in succession, then move backwards twice by two HDUs.

```
import matlab.io.*
fpPtr = fits.openFile('tst0012.fits');
n = fits.getNumHDUs(fpPtr);
for j = 1:n
 htype = fits.movAbsHDU(fpPtr,j);
 fprintf('HDU %d: "%s"\n',j,htype);
end
htype = fits.movRelHDU(fpPtr,-2);
n = fits.getHDUnum(fpPtr);
fprintf('HDU %d: "%s"\n',n,htype);
htype = fits.movRelHDU(fpPtr,-2);
n = fits.getHDUnum(fpPtr);
fprintf('HDU %d: "%s"\n',n,htype);
fits.closeFile(fpPtr);
```

**See Also** `movAbsHDU` | `movNamHDU`

# matlab.io.fits.writeChecksum

---

**Purpose** Compute and write checksum for current HDU

**Syntax** writeChecksum(fpPtr)

**Description** writeChecksum(fpPtr) computes and writes the DATASUM and CHECKSUM keyword values for the current HDU into the current header. If the keywords already exist, their values are updated only if necessary (for example, if the file has been modified since the original keyword values were computed).

This function corresponds to the fits\_write\_chksum (ffpcks) function in the CFITSIO library C API.

**Examples**

```
import matlab.io.*
fpPtr = fits.createFile('myfile.fits');
fits.createImg(fpPtr, 'long_img', [10 20]);
fits.writeChecksum(fpPtr)
fits.closeFile(fpPtr);
fitsdisp('myfile.fits', 'mode', 'full');
```

**See Also** fitsdisp

**Purpose** Compress HDU from one file into another

**Syntax** `imgCompress(infptr,outfptr)`

**Description** `imgCompress(infptr,outfptr)` initializes the output HDU, copies all the keywords, and loops through the input image, compressing the data and writing the compressed data to the output HDU.

This function corresponds to the `fits_img_compress` function in the CFITSIO library C API.

**Examples**

```
import matlab.io.*
infptr = fits.openFile('tst0012.fits');
outfptr = fits.createFile('myfile.fits');
fits.setCompressionType(outfptr,'rice');
fits.imgCompress(infptr,outfptr);
fits.closeFile(infptr);
fits.closeFile(outfptr);
```

**See Also** `setCompressionType`

# matlab.io.fits.isCompressedImg

---

**Purpose** Determine if current image is compressed

**Syntax** TF = isCompressedImg(fptr)

**Description** TF = isCompressedImg(fptr) returns true if the image in the current HDU is compressed.

This function corresponds to the `fits_is_compressed_image` function in the CFITSIO library C API.

**Examples**

```
import matlab.io.*
fptr = fits.openFile('tst0012.fits');
bool = fits.isCompressedImg(fptr);
fits.closeFile(fptr);
```

**See Also** setCompressionType

**Purpose** Set image compression type

**Syntax** `setCompressionType(fpPtr,comptype)`

**Description** `setCompressionType(fpPtr,comptype)` specifies the image compression algorithm that should be used when writing a FITS image.

Supported values for `comptype` include:

```
'GZIP'
'GZIP2'
'RICE'
'PLIO'
'HCOMPRESS'
'NOCOMPRESS'
```

This function corresponds to the `fits_set_compression_type` function in the CFITSIO library C API.

**Examples**

```
import matlab.io.*
fpPtr = fits.createFile('myfile.fits');
fits.setCompressionType(fpPtr,'GZIP2');
fits.createImg(fpPtr,'long_img',[256 512]);
data = reshape(1:256*512,[256 512]);
data = int32(data);
fits.writeImg(fpPtr,data);
fits.closeFile(fpPtr);
fitsdisp('myfile.fits','mode','full');
```

**See Also** `setTileDim` | `createImg`

# matlab.io.fits.setHCompScale

---

**Purpose** Set scale parameter for HCOMPRESS algorithm

**Syntax** `setHCompScale(fptr, scale)`

**Description** `setHCompScale(fptr, scale)` sets the scale parameter to be used with the HCOMPRESS compression algorithm. Setting the scale parameter causes the algorithm to operate in lossy mode.

This function corresponds to the `fits_set_hcomp_scale` function in the CFITSIO library C API.

**Examples**

```
import matlab.io.*
data = 50*ones(256,512,'double') + 10 * rand([256 512]);
fptr = fits.createFile('myfile.fits');
fits.setCompressionType(fptr, 'HCOMPRESS_1');
fits.setHCompScale(fptr, 2.5);
fits.createImg(fptr, 'double_img', [256 512]);
fits.writeImg(fptr, data);
fits.closeFile(fptr);
fitsdisp('myfile.fits', 'mode', 'full');
```

**See Also** `setHCompSmooth` | `setCompressionType`

**Purpose** Set smoothing for images compressed with HCOMPRESS

**Syntax** `setHCompSmooth(fpPtr,smooth)`

**Description** `setHCompSmooth(fpPtr,smooth)` sets the smoothing to be used when compressing an image with the HCOMPRESS algorithm. Setting either the scale or smoothing parameter causes the algorithm to operate in lossy mode.

This function corresponds to the `fits_set_hcomp_smooth` function in the CFITSIO library C API.

**Examples**

```
import matlab.io.*
data = int32(50*ones(256,512,'double') + 10 * rand([256 512]));
fpPtr = fits.createFile('myfile.fits');
fits.setCompressionType(fpPtr,'HCOMPRESS');
fits.setHCompSmooth(fpPtr,1);
fits.createImg(fpPtr,'long_img',[256 512]);
fits.writeImg(fpPtr,data);
fits.closeFile(fpPtr);
fitsdisp('myfile.fits','mode','full');
```

**See Also** `setHCompScale` | `setCompressionType`

# matlab.io.fits.setTileDim

---

**Purpose** Set tile dimensions

**Syntax** `fits.setTileDim(fpPtr,tiledims)`

**Description** `fits.setTileDim(fpPtr,tiledims)` specifies the size of the image compression tiles to be used when creating a compressed image.  
This function corresponds to the `fits_set_tile_dim` function in the CFITSIO library C API.

**Examples**

```
import matlab.io.*
fpPtr = fits.createFile('myfile.fits');
fits.setCompressionType(fpPtr,'RICE_1');
fits.setTileDim(fpPtr,[64 128]);
fits.createImg(fpPtr,'byte_img',[256 512]);
data = ones(256,512,'uint8');
fits.writeImg(fpPtr,data);
fits.closeFile(fpPtr);
fitsdisp('myfile.fits','mode','full');
```

**See Also** `setCompressionType`



**Purpose**

Create new ASCII or binary table extension

**Syntax**

```
fptr = createTbl(fptr,tbltype,nrows,ttype,tform,tunit,extname)
```

**Description**

`fptr = createTbl(fptr,tbltype,nrows,ttype,tform,tunit,extname)` creates a new ASCII or bintable table extension. `ttype` must be either 'binary' or 'ascii'. The `nrows` argument gives the initial number of rows to be created in the table and should normally be zero. `tunit` specifies the units for each column, but can be an empty cell array if no units are desired. `extname` specifies the extension name, but can be omitted.

`tform` specifies the format of the column. For binary tables, the values should be in the form of 'rt', where 'r' is the repeat count and 't' is one of the following letters.

'A'	ASCII character
'B'	Byte or uint8
'C'	Complex (single precision)
'D'	Double precision
'E'	Single precision
'I'	int16
'J'	int32
'K'	int64
'L'	Logical
'M'	Complex (double precision)
'X'	Bit (int8 zeros and ones)

A column can also be specified as having variable-width if the `tform` value has the form '1Pt' or '1Qt', where 't' specifies the data type as above.

For ASCII tables, the `tform` values take the form:

<code>Iw</code>	int16 column with width 'w'
<code>Aw</code>	ASCII column with width 'w'
<code>Fww.dd</code>	Fixed point
<code>Eww.dd</code>	Single precision with width 'ww' and precision 'dd'
<code>Dww.dd</code>	Double precision with width 'ww' and precision 'dd'

This function corresponds to the `fits_create_tbl` (`ffcrtb`) function in the CFITSIO library C API.

## Examples

Create a binary table. The first column contains strings of nine characters each. The second column contains four-element sequences of bits. The third column contains three-element sequences of `uint8` values. The fourth column contains double-precision scalars.

```
import matlab.io.*
fptr = fits.createFile('myfile.fits');
ttype = {'Col1', 'Col2', 'Col3', 'Col4'};
tform = {'9A', '4X', '3B', '1D'};
tunit = {'m/s', 'kg', 'kg/m^3', 'candela'};
fits.createTbl(fptr, 'binary', 10, ttype, tform, tunit, 'my-table');
fits.closeFile(fptr);
fitsdisp('myfile.fits');
```

---

Create a two-column table where the first column has a single double-precision value, but the second column has a variable-length double-precision value.

```
import matlab.io.*
fptr = fits.createFile('myfile2.fits');
ttype = {'Col1', 'Col2'};
```

```
tform = {'1D','1PD'};
fits.createTbl(fptr,'binary',0,ttype,tform);
fits.closeFile(fptr);
fitsdisp('myfile2.fits');
```

## See Also

[insertATbl](#) | [insertBTbl](#) | [readCol](#) | [writeCol](#) | [createImg](#)

# matlab.io.fits.deleteCol

---

**Purpose** Delete column from table

**Syntax** deleteCol(fptr,colnum)

**Description** deleteCol(fptr,colnum) deletes the column from an ASCII or binary table.

This function corresponds to the fits\_delete\_col (ffdcoll) function in the CFITSIO library C API.

**Examples** Delete the second column in a binary table.

```
import matlab.io.*
srcFile = fullfile(matlabroot,'toolbox','matlab','demos','tst0012.fits');
copyfile(srcFile,'myfile.fits');
fileattrib('myfile.fits','+w');
fprintf('Before: '); fitsdisp('myfile.fits','index',2,'mode','min');
fptr = fits.openFile('myfile.fits','readwrite');
fits.movAbsHDU(fptr,2);
fits.deleteCol(fptr,2);
fits.closeFile(fptr);
fprintf('After : '); fitsdisp('myfile.fits','index',2,'mode','min');
```

**See Also** deleteRows

**Purpose**

Delete rows from table

**Syntax**

```
deleteRows(fptr,firstrow,nrows)
```

**Description**

`deleteRows(fptr,firstrow,nrows)` deletes rows from an ASCII or binary table.

This function corresponds to the `fits_delete_rows` (`ffdraw`) function in the CFITSIO library C API.

**Examples**

Delete the second, third, and fourth rows in a binary table (second HDU).

```
import matlab.io.*
srcFile = fullfile(matlabroot,'toolbox','matlab','demos','tst0012.fits');
copyfile(srcFile,'myfile.fits');
fileattrib('myfile.fits','+w');
fprintf('Before: '); fitsdisp('myfile.fits','index',2,'mode','min');
fptr = fits.openFile('myfile.fits','readwrite');
fits.movAbsHDU(fptr,2);
fits.deleteRows(fptr,2,2);
fits.closeFile(fptr);
fprintf('After : '); fitsdisp('myfile.fits','index',2,'mode','min');
```

**See Also**

[deleteCol](#) | [insertRows](#)

# matlab.io.fits.insertRows

---

**Purpose** Insert rows into table

**Syntax** `insertRows(fptr,firstrow,nrows)`

**Description** `insertRows(fptr,firstrow,nrows)` inserts rows into an ASCII or binary table. `firstrow` is a one-based number.

This function corresponds to the `fits_insert_rows` (`ffrow`) function in the CFITSIO library C API.

**Examples** Insert five rows into an empty table.

```
import matlab.io.*
fptr = fits.createFile('myfile.fits');
ttype = {'Col1','Col2'};
tform = {'3A','1D'};
tunit = {'m/s','candela'};
fits.createTbl(fptr,'binary',0,ttype,tform,tunit,'my-table');
fits.insertRows(fptr,1,5);
fits.closeFile(fptr);
fitsdisp('myfile.fits','index',2);
```

**See Also** `insertCol` | `deleteRows`

**Purpose**

ASCII table information

**Syntax**

```
[ttype,tbcol,tunit,tform,scale,zero,nulstr,tdisp] = getAColParms(fptr,
 colnum)
```

**Description**

[ttype,tbcol,tunit,tform,scale,zero,nulstr,tdisp] = getAColParms(fptr, colnum) gets information about an existing ASCII table column.

This function corresponds to the fits\_get\_acolparms (fffac1) function in the CFITSIO library C API.

**Examples**

```
import matlab.io.*
fptr = fits.openFile('tst0012.fits');
fits.movAbsHDU(fptr,5);
[ttype,tbcol,tunit,tform,scale,zero,nulstr,tdisp] = fits.getAColParms
fits.closeFile(fptr);
```

**See Also**

getBColParms

# matlab.io.fits.getBColParms

---

**Purpose** Binary table information

**Syntax** [ttype,tunit,typechar,repeat,scale,zero,nulval,  
tdisp] = getBColParms(fptr,colnum)

**Description** [ttype,tunit,typechar,repeat,scale,zero,nulval, tdisp] =  
getBColParms(fptr,colnum) gets information about an existing binary  
table column.

This function corresponds to the fits\_get\_bcolparms (ffgbcl)  
function in the CFITSIO library C API.

**Examples** Get information about the second column in a binary table.

```
import matlab.io.*
fptr = fits.openFile('tst0012.fits');
fits.movAbsHDU(fptr,2);
[ttype,tunit,typechar,repeat,scale,zero,nulval,tdisp]= fits.getBColParms(
fits.closeFile(fptr);
```

**See Also** getAColParms



**Purpose** Table column name

**Syntax** [colnum,colname] = getColNum(fptr,templt,casesen)

**Description** [colnum,colname] = getColNum(fptr,templt,casesen) gets the table column numbers and names of the columns whose names match an input template name. If casesen is true, then the column name match is case-sensitive. casesen defaults to false.

The input column name template may be either the exact name of the column to be searched for, or it may contain wildcard characters (\*, ?, or #), or it may contain the integer number of the desired column (with the first column = 1). The '\*' wildcard character matches any sequence of characters (including zero characters) and the '?' character matches any single character. The # wildcard matches any consecutive string of decimal digits (0-9).

**Examples** Return all the columns starting with the letter 'C'.

```
import matlab.io.*
fptr = fits.openFile('tst0012.fits');
fits.movAbsHDU(fptr,2);
[nums,names] = fits.getColName(fptr,'C*');
fits.closeFile(fptr);
```

**See Also** getAColParms | getBColParms

# matlab.io.fits.getColType

---

**Purpose** Scaled column data type, repeat value, width

**Syntax** [dtype,repeat,width] = getColType(fptr,colnum)

**Description** [dtype,repeat,width] = getColType(fptr,colnum) returns the data type, vector repeat value, and the width in bytes of a column in an ASCII or binary table.

This function corresponds to the fits\_get\_coltype11 (ffgtc111) function in the CFITSIO library C API.

**Examples** Get information about the 'FLUX' column in the second HDU.

```
import matlab.io.*
fptr = fits.openFile('tst0012.fits');
fits.movAbsHDU(fptr,2);
[dtype,repeat,width] = fits.getColType(fptr,5);
fits.closeFile(fptr);
```

**See Also** getEqColType

**Purpose** Column data type, repeat value, width

**Syntax** [dtype,repeat,width] = getColType(fptr,colnum)

**Description** [dtype,repeat,width] = getColType(fptr,colnum) returns the scaled data type needed to store the scaled column data type, the vector repeat value, and the width in bytes of a column in an ASCII or binary table.

This function corresponds to the fits\_get\_eqcoltypell (ffeqtyll) function in the CFITSIO library C API.

**Examples** Get information about the 'FLUX' column in the second HDU.

```
import matlab.io.*
fptr = fits.openFile('tst0012.fits');
fits.movAbsHDU(fptr,2);
[dtype,repeat,width] = fits.getEqColType(fptr,5);
fits.closeFile(fptr);
```

**See Also** getColType

# matlab.io.fits.getNumCols

---

**Purpose**            Number of columns in table

**Syntax**            `ncols = getNumCols(fptr)`

**Description**      `ncols = getNumCols(fptr)` gets the number of columns in the current FITS table. This function corresponds to the `fits_get_num_cols` (`ffgncl`) function in the CFITSIO library C API.

**Examples**

```
import matlab.io.*
fptr = fits.openFile('tst0012.fits');
fits.movAbsHDU(fptr,2);
ncols = fits.getNumCols(fptr);
nrows = fits.getNumRows(fptr);
fits.closeFile(fptr);
```

**See Also**            `getNumRows`

**Purpose**            Number of rows in table

**Syntax**            `nrows = getNumRows(fpPtr)`

**Description**        `nrows = getNumRows(fpPtr)` gets the number of rows in the current FITS table. This function corresponds to the `fits_get_num_rows11` (`ffgnrwl1`) function in the CFITSIO library C API.

**Examples**

```
import matlab.io.*
fpPtr = fits.openFile('tst0012.fits');
fits.movAbsHDU(fpPtr,2);
nCols = fits.getNumCols(fpPtr);
nRows = fits.getNumRows(fpPtr);
fits.closeFile(fpPtr);
```

**See Also**            `getNumCols`

# matlab.io.fits.insertCol

---

**Purpose** Insert column into table

**Syntax** `insertCol(fpPtr,colnum,ttype,tform)`

**Description** `insertCol(fpPtr,colnum,ttype,tform)` inserts a column into an ASCII or binary table.

This function corresponds to the `fits_insert_col` (`fficol`) function in the CFITSIO library C API.

## Examples

```
import matlab.io.*
fpPtr = fits.createFile('myfile.fits');
ttype = {'Col1','Col2'};
tform = {'3A','1D'};
tunit = {'m/s','candela'};
fits.createTbl(fpPtr,'binary',0,ttype,tform,tunit,'my-table');
fits.insertCol(fpPtr,3,'Col3','3D');
fits.closeFile(fpPtr);
fitsdisp('myfile.fits','index',2);
```

**See Also** `insertRows`

## Purpose

Insert ASCII table after current HDU

## Syntax

```
insertATbl(fptr, rowlen, nrows, ttype, tbc, tform, tunit, extname)
```

## Description

`insertATbl(fptr, rowlen, nrows, ttype, tbc, tform, tunit, extname)` inserts a new ASCII table extension immediately following the current HDU. Any following extensions are shifted down to make room for the new extension. If there are no other following extensions, then the new table extension is simply appended to the end of the file. If the FITS file is currently empty then this routine creates a dummy primary array before appending the table to it. The new extension becomes the current HDU. If `rowlen` is 0, then CFITSIO calculates the default `rowlen` based on the `tbc` and `ttype` values.

`tform` can take the following forms. In each case, 'w' and 'ww' represent the widths of the ASCII columns.

Iw	int16 column
Aw	ASCII column
Fww.dd	Fixed point with 'dd' digits after the decimal point
Eww.dd	Single precision with 'dd' digits of precision
Dww.dd	Double precision with 'dd' digits of precision

Binary tables are recommended instead of ASCII tables.

This function corresponds to the `fits_insert_atbl` (`ffitab`) function in the CFITSIO library C API.

## Examples

Create an ASCII table between two images.

```
import matlab.io.*
fptr = fits.createFile('myfile.fits');
fits.createImg(fptr, 'uint8', [20 30]);
```

# matlab.io.fits.insertATbl

---

```
fits.createImg(fptr,'int16',[30 40]);
fits.movRelHDU(fptr,-1);
ttype = {'Name','Short','Fix','Double'};
tbcol = [1 17 28 43];
tform = {'A15','I10','F14.2','D12.4'};
tunit = {'','m**2','cm','km/s'};
fits.insertATbl(fptr,0,0,ttype,tbcol,tform,tunit,'my-table');
fits.writeCol(fptr,1,1,char('abracadabra','hocus-pocus'));
fits.writeCol(fptr,2,1,int16([0; 1]));
fits.writeCol(fptr,3,1,[12.4; 4/3]);
fits.writeCol(fptr,4,1,[12.4; 4e8/3]);
fits.closeFile(fptr);
fitsdisp('myfile.fits','mode','min');
```

## See Also

[createTbl](#) | [insertBTbl](#)



**Purpose** Insert binary table after current HDU

**Syntax** `insertBTbl(fptr,nrows,ttype,tform,tunit,extname,pcount)`

**Description** `insertBTbl(fptr,nrows,ttype,tform,tunit,extname,pcount)` inserts a new binary table extension immediately following the current HDU. Any following extensions are shifted down to make room for the new extension. If there are no other following extensions then the new table extension is simply appended to the end of the file. If the FITS file is currently empty then this routine creates a dummy primary array before appending the table to it. The new extension becomes the CHDU. If there are following extensions in the file and if the table contains variable-length array columns then `pcount` must specify the expected final size of the data heap. Otherwise, `pcount` must be zero.

This function corresponds to the `fits_insert_btbl` (`ffibin`) function in the CFITSIO library C API.

**Examples** Create a table following the primary array. Then, insert a new table just before it.

```
import matlab.io.*
fptr = fits.createFile('myfile.fits');
ttype = {'Col1','Col2'};
tform = {'9A','1D'};
tunit = {'m/s','candela'};
fits.createTbl(fptr,'binary',10,ttype,tform,tunit,'my-table');
fits.movRelHDU(fptr,-1);
fits.insertBTbl(fptr,5,ttype,tform,tunit,'my-new-table',0);
fits.closeFile(fptr);
fitsdisp('myfile.fits');
```

**See Also** `createTbl` | `insertATbl`

# matlab.io.fits.readATblHdr

---

**Purpose** Read header information from current ASCII table

**Syntax** [rowlen,nrows,ttype,tbcol,tform,tunit,extname] = readATblHdr(fptr)

**Description** [rowlen,nrows,ttype,tbcol,tform,tunit,extname] = readATblHdr(fptr) reads header information for the current ASCII table.

This function corresponds to the fits\_read\_atblhdr11 (ffghtb11) function in the CFITSIO library C API.

**Examples**

```
import matlab.io.*
fptr = fits.openFile('tst0012.fits');
fits.movAbsHDU(fptr,5);
[rowlen,nrows,ttype,tbcol,tform,tunit,extname] = fits.readATblHdr(fptr);
fits.closeFile(fptr);
```

**See Also** readBTblHdr

- Purpose** Read header information from current binary table
- Syntax** [nrows,ttype,tform,tunit,exname,pcount] = readBTblHdr(fptr)
- Description** [nrows,ttype,tform,tunit,exname,pcount] = readBTblHdr(fptr) reads header information for the current binary table.
- This function corresponds to the fits\_read\_btblhdr11 (ffghbn11) function in the CFITSIO library C API.
- Examples**
- ```
import matlab.io.*
fptr = fits.openFile('tst0012.fits');
fits.movAbsHDU(fptr,2);
[nrows,ttype,tform,tunit,exname,pcount] = fits.readBTblHdr(fptr);
fits.closeFile(fptr);
```
- See Also** readATblHdr

matlab.io.fits.readCol

Purpose Read rows of ASCII or binary table column

Syntax `[coldata,nullval] = readCol(fpPtr,colnum)`
`[coldata,nullval] = readCol(fpPtr,colnum,firstrow,numrows)`

Description `[coldata,nullval] = readCol(fpPtr,colnum)` reads an entire column from an ASCII or binary table column. `nullval` is a logical array specifying if a particular element of `coldata` should be treated as undefined. It is the same size as `coldata`.

`[coldata,nullval] = readCol(fpPtr,colnum,firstrow,numrows)` reads a subsection of rows from an ASCII or binary table column.

The MATLAB data type returned by `readCol` corresponds to the data type returned by `getEqColType`.

This function corresponds to the `fits_read_col (ffgcv)` function in the CFITSIO library C API.

Examples Read an entire column.

```
import matlab.io.*
fpPtr = fits.openFile('tst0012.fits');
fits.movAbsHDU(fpPtr,2);
colnum = fits.getColName(fpPtr,'flux');
fluxdata = fits.readCol(fpPtr,colnum);
fits.closeFile(fpPtr);
```

Read the first five rows in a column.

```
import matlab.io.*
fpPtr = fits.openFile('tst0012.fits');
fits.movAbsHDU(fpPtr,2);
colnum = fits.getColName(fpPtr,'flux');
fluxdata = fits.readCol(fpPtr,colnum,1,5);
fits.closeFile(fpPtr);
```

See Also `writeCol`

matlab.io.fits.setTscale

Purpose Reset image scaling

Syntax `setTscale(fptr,colnum,tscale,tzero)`

Description `setTscale(fptr,colnum,tscale,tzero)` resets the scaling factors for a table column according to the equation:

$$\text{output} = (\text{FITS array}) * \text{tscale} + \text{tzero}$$

The inverse formula is used when writing data values to the FITS file.

This only affects the automatic scaling performed when the data elements are read. It does not change the `tscale` and `tzero` keyword values.

Examples Turn off automatic scaling in a table column where the `tscale` and `tzero` keywords are present.

```
import matlab.io.*
fptr = fits.openFile('tst0012.fits');
fits.movAbsHDU(fptr,2);
scaled_data = fits.readCol(fptr,3);
fits.setTscale(fptr,3,1.0,0.0);
unscaled_data = fits.readCol(fptr,3);
fits.closeFile(fptr);
```

See Also `readImg`

| | |
|--------------------|---|
| Purpose | Write elements into ASCII or binary table column |
| Syntax | <code>writeCol(fpPtr,colnum,firstrow,coldata)</code> |
| Description | <p><code>writeCol(fpPtr,colnum,firstrow,coldata)</code> writes elements into an ASCII or binary table extension column.</p> <p>When writing rows of data to a variable length field, <code>coldata</code> must be a cell array.</p> <p>This function corresponds to the <code>fits_write_col</code> (ffpcol) function in the CFITSIO library C API.</p> |

Examples

Write to a table with ASCII, uint8, double-precision, and variable-length double-precision columns.

```
import matlab.io.*
fpPtr = fits.createFile('myfile.fits');
ttype = {'Col1','Col2','Col3','Col4'};
tform = {'3A','3B','1D','1PD'};
tunit = {'m/s','kg/m^3','candela','parsec'};
fits.createTbl(fpPtr,'binary',0,ttype,tform,tunit,'my-table');
fits.writeCol(fpPtr,1,1,['dog'; 'cat']);
fits.writeCol(fpPtr,2,1,[0 1 2; 3 4 5; 6 7 8; 9 10 11]);
fits.writeCol(fpPtr,3,1,[1; 2; 3; 4]);
fits.writeCol(fpPtr,4,1,{1;[1 2];[1 2 3];[1 2 3 4]});
fits.closeFile(fpPtr);
fitsdisp('myfile.fits','index',2,'mode','full');
```

Write to a table with logical, bit, double precision, and variable-length complex single-precision columns.

```
import matlab.io.*
fpPtr = fits.createFile('myfile.fits');
ttype = {'Col1','Col2','Col3','Col4'};
tform = {'2L','3X','1D','1PC'};
```

matlab.io.fits.writeCol

```
tunit = {'', 'kg/m^3', 'candela', 'parsec'};
fits.createTbl(fpPtr, 'binary', 0, ttype, tform, tunit, 'my-table');
fits.writeCol(fpPtr, 1, 1, [false false; true false]);
fits.writeCol(fpPtr, 2, 1, int8([0 1 1; 1 1 1; 1 1 1; 1 0 1]));
fits.writeCol(fpPtr, 3, 1, [1; 2; 3; 4]);
data = cell(4, 1);
data{1} = single(1);
data{2} = single(1+2j);
data{3} = single([1j 2 3+j]);
data{4} = single([1 2+3j 3 4]);
fits.writeCol(fpPtr, 4, 1, data);
fits.closeFile(fpPtr);
fitsdisp('myfile.fits', 'index', 2, 'mode', 'full');
```

See Also

[createTbl](#) | [readCol](#)

Purpose Numeric value of named constant

Syntax N = getConstantValue(name)

Description N = getConstantValue(name) returns the numeric value corresponding to the named CFITSIO constant.

Examples

```
import matlab.io.*  
n = fits.getConstantValue('BYTE_IMG');
```

matlab.io.fits.getVersion

Purpose Revision number of the CFITSIO library

Syntax `V = getVersion()`

Description `V = getVersion()` returns the revision number of the CFITSIO library. This function corresponds to the `fits_get_version` (`ffvers`) function in the CFITSIO library C API.

Examples

```
import matlab.io.*  
v = fits.getVersion();
```

| | |
|--------------------|---|
| Purpose | List of open FITS files |
| Syntax | <code>fptrs = getOpenFiles()</code> |
| Description | <code>fptrs = getOpenFiles()</code> returns a list of file pointers of all open FITS files. |
| Examples | <pre>import matlab.io.* fptr = fits.openFile('tst0012.fits'); clear fptr; fptr = fits.getOpenFiles(); fits.closeFile(fptr);</pre> |
| See Also | <code>openFile</code> <code>closeFile</code> |

Purpose Interact directly with HDF4 multfile scientific data set (SD) interface

Description To use these MATLAB functions, you should be familiar with the HDF SD C API. In most cases, the syntax of the MATLAB function is similar to the syntax of the corresponding HDF library function. The functions are implemented as the package `matlab.io.hdf4.sd`. To use this package, prefix the function name with a package path, or use the `import` function to add the package to the current import list, prior to calling the function, for example,

```
import matlab.io.hdf4.*
sdID = sd.start('myfile.hdf','read');
```

Access

| | |
|--|---|
| <code>matlab.io.hdf4.sd.close</code> | Terminate access to SD interface |
| <code>matlab.io.hdf4.sd.endAccess</code> | Terminate access to data set |
| <code>matlab.io.hdf4.sd.getFilename</code> | Name of file |
| <code>matlab.io.hdf4.sd.select</code> | Identifier of data set with specified index |
| <code>matlab.io.hdf4.sd.setExternalFile</code> | Store data in external file |
| <code>matlab.io.hdf4.sd.start</code> | Open HDF file and initialize SD interface |

Read/Write

| | |
|--|-------------------------------|
| <code>matlab.io.hdf4.sd.create</code> | Create new data set |
| <code>matlab.io.hdf4.sd.readData</code> | Read subsample of data |
| <code>matlab.io.hdf4.sd.setFillMode</code> | Set current fill mode of file |
| <code>matlab.io.hdf4.sd.writeData</code> | Write to data set |

Inquiry

| | |
|--|---|
| <code>matlab.io.hdf4.sd.fileInfo</code> | Number of data sets and global attributes in file |
| <code>matlab.io.hdf4.sd.getCompInfo</code> | Information about data set compression |
| <code>matlab.io.hdf4.sd.getFillValue</code> | Fill value for data set |
| <code>matlab.io.hdf4.sd.getInfo</code> | Information about data set |
| <code>matlab.io.hdf4.sd.idToRef</code> | Reference number corresponding to data set identifier |
| <code>matlab.io.hdf4.sd.idType</code> | Type of object |
| <code>matlab.io.hdf4.sd.isCoordVar</code> | Determine if data set is a coordinate variable |
| <code>matlab.io.hdf4.sd.isRecord</code> | Determine if data set is appendable |
| <code>matlab.io.hdf4.sd.nameToIndex</code> | Index value of named data set |
| <code>matlab.io.hdf4.sd.nameToIndices</code> | List of data sets with same name |
| <code>matlab.io.hdf4.sd.refToIndex</code> | Index of data set corresponding to reference number |

Dimensions

| | |
|--|--------------------------------|
| <code>matlab.io.hdf4.sd.dimInfo</code> | Information about dimension |
| <code>matlab.io.hdf4.sd.getDimID</code> | Dimension identifier |
| <code>matlab.io.hdf4.sd.getDimScale</code> | Scale data for dimension |
| <code>matlab.io.hdf4.sd.setDimName</code> | Associate name with dimension |
| <code>matlab.io.hdf4.sd.setDimScale</code> | Set scale values for dimension |

User-defined Attributes

| | |
|----------------------------|------------------------------|
| matlab.io.hdf4.sd.attrInfo | Information about attribute |
| matlab.io.hdf4.sd.findAttr | Index of specified attribute |
| matlab.io.hdf4.sd.readAttr | Read attribute value |
| matlab.io.hdf4.sd.setAttr | Write attribute value |

Predefined Attributes

| | |
|--------------------------------|--|
| matlab.io.hdf4.sd.getCal | Data set calibration information |
| matlab.io.hdf4.sd.getDataStrs | Predefined attribute strings for data set |
| matlab.io.hdf4.sd.getDimStrs | Predefined attribute strings for dimension |
| matlab.io.hdf4.sd.getFillValue | Fill value for data set |
| matlab.io.hdf4.sd.getRange | Maximum and minimum range values |
| matlab.io.hdf4.sd.setCal | Set data set calibration information |
| matlab.io.hdf4.sd.setDataStrs | Set predefined attributes for data set |
| matlab.io.hdf4.sd.setDimStrs | Set label, unit, and format attribute strings |
| matlab.io.hdf4.sd.setFillValue | Set fill value for data set |
| matlab.io.hdf4.sd.setRange | Set maximum and minimum range value for data set |

Chunking/Tiling Operations

| | |
|--------------------------------|---|
| matlab.io.hdf4.sd.getChunkInfo | Chunk size for data set |
| matlab.io.hdf4.sd.readChunk | Read chunk from data set |
| matlab.io.hdf4.sd.setChunk | Set chunk size and compression method of data set |
| matlab.io.hdf4.sd.writeChunk | Write chunk to data set |

Compression

| | |
|----------------------------------|--|
| matlab.io.hdf4.sd.setCompress | Set compression method of data set |
| matlab.io.hdf4.sd.setNBitDataSet | Specify nonstandard bit length for data set values |

matlab.io.hdf4.sd.attrInfo

Purpose Information about attribute

Syntax [name,datatype,nelts] = attrInfo(objID,idx)

Description [name,datatype,nelts] = attrInfo(objID,idx) returns the name, data type, and number of elements in the specified attribute. The attribute is specified by its zero-based index value. objID can be either an SD interface identifier, a data set identifier, or a dimension identifier.

This function corresponds to the SDattrinfo function in the HDF library C API.

Examples

```
import matlab.io.hdf4.*
sdID = sd.start('sd.hdf');
idx = sd.findAttr(sdID,'creation_date');
[name,datatype,nelts] = sd.attrInfo(sdID,idx);
data = sd.readAttr(sdID,idx);
sd.close(sdID);
```

See Also sd.findAttr

Purpose Terminate access to SD interface

Syntax `sd.close(sdID)`

Description `sd.close(sdID)` closes the file identified by `sdID`.
This function corresponds to the `SDend` function in the HDF C API.

Examples

```
import matlab.io.hdf4.*
sdID = sd.start('sd.hdf');
idx = sd.nameToIndex(sdID,'temperature');
sdsID = sd.select(sdID,idx);
sd.endAccess(sdsID);
sd.close(sdID);
```

See Also `sd.start`

matlab.io.hdf4.sd.create

Purpose Create new data set

Syntax `sdsID = create(sdID,name,datatype,dims)`

Description `sdsID = create(sdID,name,datatype,dims)` creates a data set with the given name `name`, data type `datatype`, and dimension sizes `dims`.

To create a data set with an unlimited dimension, the last value in `dims` should be set to 0.

This function corresponds to the `SDcreate` function in the HDF library C API, but because MATLAB uses FORTRAN-style ordering, the `dims` parameter is reversed with respect to the C library API.

Examples Create a 3D data set with an unlimited dimension.

```
import matlab.io.hdf4.*
sdID = sd.start('myfile.hdf','create');
sdsID = sd.create(sdID,'temperature','double',[10 20 0]);
sd.endAccess(sdsID);
sd.close(sdID);
```

See Also `sd.endAccess`

Purpose Information about dimension

Syntax [name,dimlen,datatype,nattrs] = dimInfo(dimID)

Description [name,dimlen,datatype,nattrs] = dimInfo(dimID) returns the name, length, data type, and number of attributes of the specified dimension.

This function corresponds to the SDdiminfo function in the HDF library C API.

Examples Read a 2-by-3 portion of a data set.

```
import matlab.io.hdf4.*
sdID = sd.start('sd.hdf');
idx = sd.nameToIndex(sdID,'latitude');
sdsID = sd.select(sdID,idx);
dimID = sd.getDimID(sdsID,0);
[name,dimlen,datatype,nattrs] = sd.dimInfo(dimID);
sd.endAccess(sdsID);
sd.close(sdID);
```

See Also sd.getDimID

matlab.io.hdf4.sd.endAccess

Purpose Terminate access to data set

Syntax `sd.endAccess(sdsID)`

Description `sd.endAccess(sdsID)` terminates access to the data set identified by `sdsID`. Failing to call this function after all operations on the specified data set are complete may result in loss of data.

This function corresponds to the `SDendaccess` function in the HDF library C API.

Examples

```
import matlab.io.hdf4.*
sdID = sd.start('sd.hdf');
idx = sd.nameToIndex(sdID,'temperature');
sdsID = sd.select(sdID,idx);
sd.endAccess(sdsID);
sd.close(sdID);
```

See Also `sd.select` | `sd.close`

Purpose Number of data sets and global attributes in file

Syntax `[ndatasets,ngatts] = fileInfo(sdID)`

Description `[ndatasets,ngatts] = fileInfo(sdID)` returns the number of data sets `ndatasets` and the number of global attributes `ngatts` in the file identified by `sdID`.

`ndatasets` includes the number of coordinate variable data sets.

This function corresponds to the `SDfileinfo` function in the HDF library C API.

Examples

```
import matlab.io.hdf4.*
sdID = sd.start('sd.hdf');
[ndatasets,ngatts] = sd.fileInfo(sdID);
sd.close(sdID);
```

See Also `sd.getInfo`

matlab.io.hdf4.sd.findAttr

Purpose Index of specified attribute

Syntax `idx = findAttr(objID,attrname)`

Description `idx = findAttr(objID,attrname)` returns the index of the attribute specified by `attrname`. The `objID` input can be either an SD interface identifier, a data set identifier, or a dimension identifier.

The function corresponds to the `SDfindattr` function in the HDF library C API.

Examples

```
import matlab.io.hdf4.*
sdID = sd.start('sd.hdf');
idx = sd.findAttr(sdID,'creation_date');
data = sd.readAttr(sdID,idx);
sd.close(sdID);
```

See Also `sd.start` | `sd.select` | `sd.getDimID` | `sd.readAttr`

Purpose Data set calibration information

Syntax [cal,calErr,offset,offsetErr,datatype] = getCal(sdsID)

Description [cal,calErr,offset,offsetErr,datatype] = getCal(sdsID) retrieves the calibration information associated with a data set.

This function corresponds to the SDgetcal function in the HDF library C API.

Examples

```
import matlab.io.hdf4.*
sdID = sd.start('sd.hdf');
idx = sd.nameToIndex(sdID,'temperature');
sdsID = sd.select(sdID,idx);
[cal,calErr,offset,offsetErr,dtype] = sd.getCal(sdsID);
sd.endAccess(sdsID);
sd.close(sdID);
```

See Also sd.setCal

matlab.io.hdf4.sd.getChunkInfo

Purpose Chunk size for data set

Syntax chunkDims = getChunkInfo(sdsID)

Description chunkDims = getChunkInfo(sdsID) returns the chunk size for the data set specified by sdsID. If a data set is chunked, the dimensions of the chunks is returned in chunkDims. Otherwise chunkDims is [].

This function corresponds to the SDgetchunkinfo function in the HDF library C API, but because MATLAB uses FORTRAN-style ordering, the chunkDims parameter is reversed with respect to the C library API.

Examples

```
import matlab.io.hdf4.*
sdID = sd.start('sd.hdf');
idx = sd.nameToIndex(sdID,'temperature');
sdsID = sd.select(sdID,idx);
cdims = sd.getChunkInfo(sdsID);
sd.endAccess(sdsID);
sd.close(sdID);
```

See Also sd.setChunk | sd.getCompInfo

Purpose Information about data set compression

Syntax [comptype,compparms] = getCompType(sdsID)

Description [comptype,compparms] = getCompType(sdsID) retrieves the compression type and compression information for a data set. `comptype` can be one of the following strings.

| | |
|-----------|------------------------------|
| 'none' | No compression |
| 'rle' | Run-length encoding |
| 'nbit' | NBIT compression |
| 'skphuff' | Skipping Huffman compression |
| 'deflate' | GZIP compression |
| 'szip' | SZIP compression |

If `comptype` is 'none' or 'rle', then `compparms` is [].

If `comptype` is 'nbit', then `compparms` is a 4-element array.

| | |
|--------------------------|------------------------|
| <code>compparm(1)</code> | <code>sign_ext</code> |
| <code>compparm(2)</code> | <code>fill_one</code> |
| <code>compparm(3)</code> | <code>start_bit</code> |
| <code>compparm(4)</code> | <code>bit_len</code> |

If `comptype` is 'deflate', then `compparms` contains the deflation value, a number between 0 and 9.

If `comptype` is 'szip', then `compparms` is a 5-element array. Consult the HDF Reference Manual for details on SZIP compression.

This function corresponds to the `SDgetcompinfo` function in the HDF library C API.

matlab.io.hdf4.sd.getCompInfo

Examples

```
import matlab.io.hdf4.*
sdID = sd.start('myfile.hdf','create');
sdsID = sd.create(sdID,'temperature','double',[100 50]);
sd.setCompress(sdsID,'deflate',5);
[comptype,compparm] = sd.getCompInfo(sdsID);
sd.endAccess(sdsID);
sd.close(sdID);
```

See Also

[sd.setCompress](#) | [sd.setNBitDataSet](#)

Purpose

Predefined attribute strings for data set

Syntax

```
[label,unit,format,coordsys] = getDataStrs(sdsID)
[label,unit,format,coordsys] = getDataStrs(sdsID,maxlen)
```

Description

[label,unit,format,coordsys] = getDataStrs(sdsID) returns the label, unit, format, and coordsys attributes for the data set identified by sdsID.

[label,unit,format,coordsys] = getDataStrs(sdsID,maxlen) returns the label, unit, format, and coordsys attributes for the data set identified by sdsID. The maxlen input is the maximum length of any of the attribute strings. It defaults to 1000 if not specified.

This function corresponds to the SDgetdatastrs function in the HDF library C API.

Examples

```
import matlab.io.hdf4.*
sdID = sd.start('sd.hdf');
idx = sd.nameToIndex(sdID,'temperature');
sdsID = sd.select(sdID,idx);
[label,unit,fmt,coordsys] = sd.getDataStrs(sdsID);
sd.endAccess(sdsID);
sd.close(sdID);
```

See Also

sd.setDataStrs

matlab.io.hdf4.sd.getDimID

Purpose Dimension identifier

Syntax `dimID = getDimID(sdsID,dimnumber)`

Description `dimID = getDimID(sdsID,dimnumber)` returns the identifier of the dimension given its index.

Note Note: MATLAB uses Fortran-style indexing while the HDF library uses C-style indexing. The order of the dimension identifiers retrieved with `sd.getDimID` are reversed from what would be retrieved via the C API.

This function corresponds to the `SDgetdimid` function in the HDF library C API.

Examples Read an entire data set.

```
import matlab.io.hdf4.*
sdID = sd.start('sd.hdf');
idx = sd.nameToIndex(sdID,'temperature');
sdsID = sd.select(sdID,idx);
dimID0 = sd.getDimID(sdsID,0);
dimID1 = sd.getDimID(sdsID,1);
sd.endAccess(sdsID);
sd.close(sdID);
```

See Also `sd.setDimName`

Purpose Scale data for dimension

Syntax `scale = getDimScale(dimID)`

Description `scale = getDimScale(dimID)` returns the scale values of the dimension identified by `dimID`.

This function corresponds to the `SDgetdimscale` function in the HDF library C API.

Examples

```
import matlab.io.hdf4.*
sdID = sd.start('myfile.hdf','create');
sdsID = sd.create(sdID,'temperature','double',20);
dimID = sd.getDimID(sdsID,0);
sd.setDimName(dimID,'x');
sd.setDimScale(dimID,0:5:95);
sd.endAccess(sdsID);
sd.close(sdID);
sdID = sd.start('myfile.hdf');
idx = sd.nameToIndex(sdID,'temperature');
sdsID = sd.select(sdID,idx);
dimID = sd.getDimID(sdsID,0);
scale = sd.getDimScale(dimID);
sd.endAccess(sdsID);
sd.close(sdID);
```

See Also `sd.dimInfo` | `sd.setDimScale`

matlab.io.hdf4.sd.getDimStrs

Purpose Predefined attribute strings for dimension

Syntax [label,unit,format] = getDimStrs(dimID)

Description [label,unit,format] = getDimStrs(dimID) returns the label, unit, and format attributes for the dimension identified by dimID.

This function corresponds to the SDgetdimstrs function in the HDF library C API.

Examples

```
import matlab.io.hdf4.*
sdID = sd.start('myfile.hdf','create');
sdsID = sd.create(sdID,'temperature','double',20);
dimID = sd.getDimID(sdsID,0);
sd.setDimName(dimID,'x');
sd.setDimStrs(dimID,'xdim','none','%d');
sd.endAccess(sdsID);
sd.close(sdID);
sdID = sd.start('myfile.hdf');
idx = sd.nameToIndex(sdID,'temperature');
sdsID = sd.select(sdID,idx);
dimID = sd.getDimID(sdsID,0);
[label,unit,fmt] = sd.getDimStrs(dimID);
sd.endAccess(sdsID);
sd.close(sdID);
```

See Also sd.setDimStrs

Purpose Name of file

Syntax filename = getFilename(sdID)

Description filename = getFilename(sdID) retrieves the name of a file previously opened with the sd package with identifier sdID.

This function corresponds to the SDgetfilename function in the HDF library C API.

Examples

```
import matlab.io.hdf4.*
sdID = sd.start('sd.hdf');
filename = sd.getFilename(sdID);
sd.close(sdID);
```

See Also sd.start | sd.getInfo

matlab.io.hdf4.sd.getFillValue

Purpose Fill value for data set

Syntax `fillvalue = getFillValue(sdsID)`

Description `fillvalue = getFillValue(sdsID)` returns the fill value for a data set.

This function corresponds to the `SDgetfillvalue` function in the HDF library C API.

Examples

```
import matlab.io.hdf4.*
sdID = sd.start('sd.hdf');
idx = sd.nameToIndex(sdID, 'temperature');
sdsID = sd.select(sdID, idx);
fillvalue = sd.getFillValue(sdsID);
sd.endAccess(sdsID);
sd.close(sdID);
```

See Also `sd.setFillValue`

Purpose Information about data set

Syntax [name,dims,datatype,nattrs] = getInfo(sdsID)

Description [name,dims,datatype,nattrs] = getInfo(sdsID) returns the name, extents, and number of attributes of the data set identified by sdsID.

This function corresponds to the `SDgetinfo` function in the HDF library C API, but because MATLAB uses FORTRAN-style ordering, the `dims` parameter is reversed with respect to the C library API.

Examples

```
import matlab.io.hdf4.*
sdID = sd.start('sd.hdf');
idx = sd.nameToIndex(sdID,'temperature');
sdsID = sd.select(sdID,idx);
[name,dims,datatype,nattrs] = sd.getInfo(sdsID);
sd.endAccess(sdsID);
sd.close(sdID);
```

See Also [sd.dimInfo](#) | [sd.attrInfo](#) | [sd.fileInfo](#)

matlab.io.hdf4.sd.getRange

| | |
|--------------------|---|
| Purpose | Maximum and minimum range values |
| Syntax | <code>[maxval,minval] = getRange(sdsID)</code> |
| Description | <code>[maxval,minval] = getRange(sdsID)</code> retrieves the "valid_range" two-element attribute value.

This function corresponds to the SDgetrange function in the HDF library C API. |
| Examples | <pre>import matlab.io.hdf4.* sdID = sd.start('sd.hdf'); idx = sd.nameToIndex(sdID,'temperature'); sdsID = sd.select(sdID,idx); [maxval,minval] = sd.getRange(sdsID); sd.endAccess(sdsID); sd.close(sdID);</pre> |
| See Also | <code>sd.setRange</code> |

Purpose Reference number corresponding to data set identifier

Syntax `ref = idToRef(sdsID)`

Description `ref = idToRef(sdsID)` returns the reference number corresponding to the data set.

This function corresponds to the `SDidtoRef` function in the HDF library C API.

Examples

```
import matlab.io.hdf4.*
sdID = sd.start('sd.hdf');
idx = sd.nameToIndex(sdID,'temperature');
sdsID = sd.select(sdID,idx);
ref = sd.idToRef(sdsID);
sd.endAccess(sdsID);
sd.close(sdID);
```

See Also `sd.refToIndex` |

matlab.io.hdf4.sd.idType

Purpose Type of object

Syntax `objtype = idType(objID)`

Description `objtype = idType(objID)` returns the type of object that `objID` represents. Possible values for `objtype` are:

| | |
|----------------|--|
| 'NOT_SDAPI_ID' | The object is not an HDF SD identifier. |
| 'SD_ID' | The object is an SD identifier (file handle) . |
| 'SDS_ID' | The object is a data set identifier. |
| 'DIM_ID' | The object is a dimension identifier. |

This function corresponds to the `SDidtype` function in the HDF library C API.

Examples

```
import matlab.io.hdf4.*
sdID = sd.start('sd.hdf');
objType = sd.idType(sdID);
sd.close(sdID);
```

Purpose Determine if data set is a coordinate variable

Syntax TF = isCoordVar(sdsID)

Description TF = isCoordVar(sdsID) returns true if a data set is a coordinate variable and returns false otherwise.

This function corresponds to the SDisoordvar function in the HDF library C API.

Examples

```
import matlab.io.hdf4.*
sdID = sd.start('sd.hdf');
ndataset = sd.fileInfo(sdID);
for idx = 0:ndataset-1
    sdsID = sd.select(sdID,idx);
    sdsName = sd.getInfo(sdsID);
    fprintf('%s (index %d) ', sdsName, idx);
    if ( sd.isCoordVar(sdsID) )
        fprintf('is a coordinate variable.\n');
    else
        fprintf('is not a coordinate variable.\n');
    end
    sd.endAccess(sdsID);
end
sd.close(sdID);
```

See Also sd.isRecord

matlab.io.hdf4.sd.isRecord

Purpose Determine if data set is appendable

Syntax TF = isRecord(sdsID)

Description TF = isRecord(sdsID) determines if the data set specified by sdsID is appendable, meaning that the slowest changing dimension is unlimited. This function corresponds to the SDisrecord function in the HDF library C API.

Examples

```
import matlab.io.hdf4.*
sdID = sd.start('sd.hdf');
ndataset = sd.fileInfo(sdID);
for idx = 0:ndataset-1
    sdsID = sd.select(sdID,idx);
    sdsName = sd.getInfo(sdsID);
    if sd.isRecord(sdsID)
        fprintf('%s is a record variable.\n',sdsName);
    else
        fprintf('%s is not a record variable.\n',sdsName);
    end
    sd.endAccess(sdsID);
end
sd.close(sdID);
```

See Also sd.isCoordVar

Purpose Index value of named data set

Syntax `idx = nameToIndex(sdID,sdsname)`

Description `idx = nameToIndex(sdID,sdsname)` returns the index of the data set with the name specified by `sdsname`. If there is more than one data set with the same name, the routine returns the index of the first one.

This function corresponds to the `SDnametoindex` function in the HDF C API.

Examples

```
import matlab.io.hdf4.*
sdID = sd.start('sd.hdf','read');
idx = sd.nameToIndex(sdID,'temperature');
sd.close(sdID);
```

See Also `sd.select`

matlab.io.hdf4.sd.nameToIndices

Purpose List of data sets with same name

Syntax `varstruct = nameToIndices(sdID,sdsname)`

Description `varstruct = nameToIndices(sdID,sdsname)` returns a structure array for all data sets with the same name. Each element of `varstruct` has two fields.

| | |
|----------------------|---|
| <code>'index'</code> | Index of data set |
| <code>'type'</code> | Type of data set, either 'SDSVAR', 'COORDVAR', or 'UNKNOWN' |

This function corresponds to the `SDnametoindices` function in the HDF library C API.

Examples

```
import matlab.io.hdf4.*
sdID = sd.start('sd.hdf');
varlist = sd.nameToIndices(sdID,'latitude');
sd.close(sdID);
```

See Also `sd.setDimScale` | `sd.isCoordVar`

Purpose Read attribute value

Syntax `data = readAttr(objID,idx)`

Description `data = readAttr(objID,idx)` reads the value of the attribute specified by index `idx`. The `objID` input can be an SD interface identifier, a data set identifier, or a dimension identifier. `idx` is a zero-based index.

This function corresponds to the `SDreadattr` function in the HDF library C API.

Examples

```
import matlab.io.hdf4.*
sdID = sd.start('sd.hdf');
idx = sd.findAttr(sdID,'creation_date');
data = sd.readAttr(sdID,idx);
sd.close(sdID);
```

See Also `sd.findAttr` | `sd.setAttr`

matlab.io.hdf4.sd.readChunk

Purpose Read chunk from data set

Syntax datachunk = readChunk(sdsID,origin)

Description datachunk = readChunk(sdsID,origin) reads an entire chunk of data from the data set identified by sdsID. The origin input specifies the location of the chunk in zero-based chunking coordinates, not in data set coordinates.

This function corresponds to the SDreadchunk function in the HDF library C API, but because MATLAB uses FORTRAN-style ordering, the origin parameter is reversed with respect to the C library API.

Examples

```
import matlab.io.hdf4.*
sdID = sd.start('sd.hdf');
idx = sd.nameToIndex(sdID,'temperature');
sdsID = sd.select(sdID,idx);
dataChunk = sd.readChunk(sdsID,[0 1]);
sd.endAccess(sdsID);
sd.close(sdID);
```

See Also sd.writeChunk | sd.writeData

Purpose

Read subsample of data

Syntax

```
data = readData(sdsID)
data = readData(sdsID,start,count)
data = readData(sdsID,start,count,stride)
```

Description

`data = readData(sdsID)` reads all of the data for the data set identified by `sdsID`.

`data = readData(sdsID,start,count)` reads a contiguous hyperslab of data from the data set identified by `sdsID`. The `start` input specifies the starting position from where the hyperslab is read. `count` specifies the number of values to read along each data set dimension.

`data = readData(sdsID,start,count,stride)` reads a strided hyperslab of data from the data set identified by `sdsID`.

`start`, `count`, and `stride` use zero-based indexing.

This function corresponds to the `SDreaddata` function in the HDF library C API, but because MATLAB uses FORTRAN-style ordering, the `start`, `count`, and `stride` parameters are reversed with respect to the C library API.

Examples

Read an entire data set.

```
import matlab.io.hdf4.*
sdID = sd.start('sd.hdf');
idx = sd.nameToIndex(sdID,'temperature');
sdsID = sd.select(sdID,idx);
data = sd.readData(sdsID);
sd.endAccess(sdsID);
sd.close(sdID);
```

Read a 2-by-3 portion of a data set.

```
import matlab.io.hdf4.*
```

matlab.io.hdf4.sd.readData

```
sdID = sd.start('sd.hdf');  
idx = sd.nameToIndex(sdID,'temperature');  
sdsID = sd.select(sdID,idx);  
data = sd.readData(sdsID,[0 0],[2 3]);  
sd.endAccess(sdsID);  
sd.close(sdID);
```

See Also

`sd.writeData`

Purpose Index of data set corresponding to reference number

Syntax `idx = refToIndex(sdID,ref)`

Description `idx = refToIndex(sdID,ref)` returns the index of the data set identified by its reference number `ref`. The `idx` output can then be passed to `sd.select`, to obtain a data set identifier.

This function corresponds to the `SDrefToIndex` function in the HDF library C API.

Examples

```
import matlab.io.hdf4.*
sdID = sd.start('sd.hdf','read');
idx = sd.nameToIndex(sdID,'temperature');
sdsID = sd.select(sdID,idx);
ref = sd.idToRef(sdsID);
idx2 = sd.refToIndex(sdID,ref);
sd.endAccess(sdsID);
sd.close(sdID);
```

See Also `sd.idToRef` | `sd.select`

matlab.io.hdf4.sd.select

Purpose Identifier of data set with specified index

Syntax `sdsID = select(sdID,IDX)`

Description `sdsID = select(sdID,IDX)` returns the identifier of the data set specified by its index.

This function corresponds to the `SDselect` function in the HDF C library.

Examples

```
import matlab.io.hdf4.*
sdID = sd.start('sd.hdf','read');
idx = sd.nameToIndex(sdID,'temperature');
sdsID = sd.select(sdID,idx);
sd.endAccess(sdsID);
sd.close(sdID);
```

See Also `sd.endAccess` | `sd.nameToIndex`

Purpose Write attribute value

Syntax `setAttr(objID,name,value)`

Description `setAttr(objID,name,value)` attaches an attribute to the object specified by `objID`. If `objID` is the SD interface identifier, then a global attribute is created. If a data identifier is specified, then the attribute is attached to the data set. If a dimension identifier is specified, then the attribute is attached to the dimension.

This function corresponds to the `SDsetattr` function in the HDF library C API.

Examples Attach attributes to a file, a data set, and to a dimension.

```
import matlab.io.hdf4.*
sdID = sd.start('myfile.hdf','create');
sd.setAttr(sdID,'creation_date',datestr(now));
sdsID = sd.create(sdID,'temperature','double',[10 20]);
sd.setAttr(sdsID,'long_name','Temperature in sunlight.');
```

```
dimID0 = sd.getDimID(sdsID,0);
sd.setAttr(dimID0,'long_name','latitude');
sd.endAccess(sdsID);
sd.close(sdID);
```

See Also `sd.readAttr` | `sd.findAttr`

matlab.io.hdf4.sd.setCal

Purpose Set data set calibration information

Syntax `setCal(sdsID,cal,calErr,offset,offsetErr,datatype)`

Description `setCal(sdsID,cal,calErr,offset,offsetErr,datatype)` sets the calibration information for a data set.

This function corresponds to the `SDsetcal` function in the HDF library C API.

Examples

```
import matlab.io.hdf4.*
sdID = sd.start('myfile.hdf','create');
sdsID = sd.create(sdID,'temperature','double',[10 20]);
sd.setDataStrs(sdsID,'Temperature','degrees_kelvin','%.3f','spherical');
sd.setCal(sdsID,1,0,273,0,'double');
sd.endAccess(sdsID);
sd.close(sdID);
```

See Also `sd.getCal`

Purpose Set chunk size and compression method of data set

Syntax `setChunk(sdsID, chunkSize, comptype, compparm)`

Description `setChunk(sdsID, chunkSize, comptype, compparm)` makes the data set specified by `sdsID` a chunked data set with chunk size given by `chunkSize` and compression specified by `comptype` and `compparm`. The `comptype` input can be one of the following strings.

| | |
|-----------|------------------------------|
| 'none' | No compression |
| 'skphuff' | Skipping Huffman compression |
| 'deflate' | GZIP compression |
| 'rle' | Run-length encoding |

- If `comptype` is 'none' or 'rle', then `compparm` need not be specified.
- If `comptype` is 'skphuff', then `compparm` is the skipping size.
- If `comptype` is 'deflate', then `compparm` is the deflate level, which must be between 0 and 9.

This function corresponds to the `SDsetchunk` function in the HDF library C API, but because MATLAB uses FORTRAN-style ordering, the `chunkSize` parameter is reversed with respect to the C library API.

Examples

```
import matlab.io.hdf4.*
sdID = sd.start('myfile.hdf', 'create');
sdsID = sd.create(sdID, 'temperature', 'double', [200 100]);
sd.setChunk(sdsID, [20 10], 'skphuff', 16);
sd.endAccess(sdsID);
sd.close(sdID);
```

See Also `sd.readChunk` | `sd.writeChunk`

matlab.io.hdf4.sd.setCompress

Purpose Set compression method of data set

Syntax `setCompress(sdsID,comptype,compparm)`

Description `setCompress(sdsID,comptype,compparm)` sets the compression scheme for the specified data set. The compression must be done before writing the data set. `comptype` can be one of the following strings.

| | |
|-----------|------------------------------|
| 'none' | No compression |
| 'skphuff' | Skipping Huffman compression |
| 'deflate' | GZIP compression |
| 'rle' | Run-length encoding |

- If `comptype` is 'none' or 'rle', then `compparm` need not be specified.
- If `comptype` is 'skphuff', then `compparm` is the skipping size.
- If `comptype` is 'deflate', then `compparm` is the deflate level, which must be between 0 and 9.

This function corresponds to the `SDsetcompress` function in the HDF library C API.

Examples

```
import matlab.io.hdf4.*
sdID = sd.start('myfile.hdf','create');
sdsID = sd.create(sdID,'temperature','double',[200 100]);
sd.setCompress(sdsID,'deflate',5);
data = rand(200,100);
sd.writeData(sdsID,[0 0],data);
sd.endAccess(sdsID);
sd.close(sdID);
```

See Also `sd.setChunk`

Purpose Set predefined attributes for data set

Syntax `setDataStrs(sdsID,label,unit,format,coordsys)`

Description `setDataStrs(sdsID,label,unit,format,coordsys)` sets the predefined attributes 'long_name', 'units', 'format', and 'coordsys' for a data set.

This function corresponds to the `SDsetdatastrs` function in the HDF library C API.

Examples

```
import matlab.io.hdf4.*
sdID = sd.start('myfile.hdf','create');
sdsID = sd.create(sdID,'temperature','double',[10 20]);
sd.setDataStrs(sdsID,'degrees_celsius','degrees_east','','geo');
sd.endAccess(sdsID);
sd.close(sdID);
```

See Also `sd.getDataStrs` | `sd.setDimStrs`

matlab.io.hdf4.sd.setDimName

Purpose Associate name with dimension

Syntax `setDimName(dimID,dimname)`

Description `setDimName(dimID,dimname)` sets the name of the dimension identified by `dimID` to `dimname`.

This function corresponds to the `SDsetdimname` function in the HDF library C API.

Examples Create a 2D data set with dimensions 'lat' and 'lon'.

```
import matlab.io.hdf4.*
sdID = sd.start('myfile.hdf','create');
sdsID = sd.create(sdID,'temperature','double',[10 20]);
dimID = sd.getDimID(sdsID,0);
sd.setDimName(dimID,'lat');
dimID = sd.getDimID(sdsID,1);
sd.setDimName(dimID,'lon');
sd.endAccess(sdsID);
sd.close(sdID);
```

See Also `sd.dimInfo`

Purpose Set scale values for dimension

Syntax `setDimScale(dimID,scaledata)`

Description `setDimScale(dimID,scaledata)` sets the scale values for a dimension. This function corresponds to the `SDsetdimscale` function in the HDF library C API.

Examples Create a 2D data set with dimensions 'lat' and 'lon'.

```
import matlab.io.hdf4.*
sdID = sd.start('myfile.hdf','create');
sdsID = sd.create(sdID,'temperature','double',[10 20]);
dimID = sd.getDimID(sdsID,0);
sd.setDimName(dimID,'lat');
sd.setDimScale(dimID,0:10:90);
dimID = sd.getDimID(sdsID,1);
sd.setDimName(dimID,'lon');
sd.setDimScale(dimID, -180:18:179);
sd.endAccess(sdsID);
sd.close(sdID);
```

See Also `sd.getDimScale`

matlab.io.hdf4.sd.setDimStrs

Purpose Set label, unit, and format attribute strings

Syntax `setDimStrs(dimID,label,unit,format)`

Description `setDimStrs(dimID,label,unit,format)` sets the label, unit, and format attributes for the dimension identified by `dimID`.

This function corresponds to the `SDsetdimstrs` function in the HDF library C API.

Examples

```
import matlab.io.hdf4.*
sdID = sd.start('myfile.hdf','create');
sdsID = sd.create(sdID,'temperature','double',[10 20]);
dimID = sd.getDimID(sdsID,0);
sd.setDimName(dimID,'lat');
dimID = sd.getDimID(sdsID,1);
sd.setDimName(dimID,'lon');
sd.setDimStrs(dimID,'Degrees of Longitude','degrees_east','%.2f');
sd.endAccess(sdsID);
sd.close(sdID);
```

See Also `sd.getDimStrs`

Purpose

Store data in external file

Syntax

```
setExternalFile(sdsID,extfile,offset)
```

Description

`setExternalFile(sdsID,extfile,offset)` moves data values (not metadata) into the external data file `extfile` starting at the byte `offset`.

Data can only be moved once for any given data set. The external file should be kept with the main file.

This function corresponds to the `SDsetexternalfile` function in the HDF library C API.

Examples

```
import matlab.io.hdf4.*
sdID = sd.start('myfile.hdf','create');
sdsID = sd.create(sdID,'temperature','double',[10 20]);
sd.setExternalFile(sdsID,'myExternalFile.dat',0);
sd.writeData(sdsID,[0 0],rand(10,20));
sd.endAccess(sdsID);
sd.close(sdID);
```

See Also

`sd.create` | `sd.writeData`

matlab.io.hdf4.sd.setFillMode

Purpose Set current fill mode of file

Syntax `prevmode = setFillMode(sdID,fillmode)`

Description `prevmode = setFillMode(sdID,fillmode)` returns the previous fill mode of a file and resets it to `fillmode`. This setting applies to all data sets contained in the file identified by `sdID`.

Possible values of `fillmode` are 'fill', and 'nofill'. 'fill' is the default mode and indicates that fill values will be written when the data set is created. 'nofill' indicates that the fill values will not be written.

When a fixed-size data set is created, the first call to `sd.writeData` will fill the entire data set with the default or user-defined fill value if `fillmode` is 'fill'. In data sets with an unlimited dimension, if a new write operation takes place along the unlimited dimension beyond the last location of the previous write operation, the array locations between these written areas will be initialized to the user-defined fill value, or the default fill value if a user-defined fill value has not been specified.

If it is certain that all data set values will be written before any read operation takes place, there is no need to write the fill values. Calling `sd.setFillMode` with 'nofill' can improve performance in this case.

This function corresponds to the `SDsetfillmode` function in the HDF library C API.

Examples

Write two partial records. Write the first in 'nofill' mode, and the second with 'fill' mode.

```
import matlab.io.hdf4.*
sdID = sd.start('myfile.hdf','create');
sd.setFillMode(sdID,'nofill');
sdsID = sd.create(sdID,'temperature','double',[10 10 0]);
sd.writeData(sdsID,[0 0 0], rand(5,5));
sd.setFillMode(sdID,'fill');
sd.setFillValue(sdsID,-999);
sd.writeData(sdsID,[0 0 1], rand(5,5));
sd.endAccess(sdsID);
```



```
sd.close(sdID);
```

See Also

```
sd.setFillValue | sd.getFillValue
```

matlab.io.hdf4.sd.setFillValue

Purpose Set fill value for data set

Syntax `setFillValue(sdsID,fillValue)`

Description `setFillValue(sdsID,fillValue)` sets the fill value for a data set. The fill value must have the same data type as the data set.

This function corresponds to the `SDsetfillvalue` function in the HDF library C API.

Examples

```
import matlab.io.hdf4.*
sdID = sd.start('myfile.hdf','create');
sdsID = sd.create(sdID,'temperature','double',[10 20]);
sd.setFillValue(sdsID,-999);
sd.endAccess(sdsID);
sd.close(sdID);
```

See Also `sd.getFillValue`

Purpose

Specify nonstandard bit length for data set values

Syntax

`setNBitDataSet(sdsID,startBit,bitlen,ext,fillone)`

Description

`setNBitDataSet(sdsID,startBit,bitlen,ext,fillone)` specifies that the integer data set identified by `sdsID` contains data of a non-standard length defined by `startBit` and `bitlen`.

Any length between 1 and 32 bits can be specified. After `setNBitDataset` has been called for the data set array, any read or write operation will involve conversion between the new data length of the data set array and the data length of the read or write buffer.

Bit lengths of all data types are counted from the right of the bit field starting with 0. In a bit field containing the values 01111011, bits 2 and 7 are set to 0 and all the other bits are set to 1. The least significant bit is bit 0.

The `startBit` parameter specifies the left-most position of the variable-length bit field to be written. For example, in the bit field described in the preceding paragraph a `startBit` parameter set to 4 would correspond to the fourth bit value of 1 from the right.

The parameter `bitlen` specifies the number of bits of the variable-length bit field to be written. This number includes the starting bit and the count proceeds toward the right end of the bit field - toward the lower-bit numbers. For example, starting at bit 5 and writing 4 bits of the bit field described in the preceding paragraph would result in the bit field 1110 being written to the data set. This would correspond to a `startBit` value of 5 and a `bitlen` value of 4.

The parameter `ext` specifies whether to use the left-most bit of the variable-length bit field to sign-extend to the left-most bit of the data set data. For example, if 9-bit signed integer data is extracted from bits 17-25 and the bit in position 25 is 1, then when the data is read back from disk, bits 26-31 will be set to 1. Otherwise bit 25 will be 0 and bits 26-31 will be set to 0. The `ext` parameter can be set to `true` (or 1) or `false` (or 0); specify `true` to sign-extend.

matlab.io.hdf4.sd.setNBitDataSet

The parameter `fillone` specifies whether to fill the "background" bits with the value 1 or 0. This parameter is also set to either `true` (or 1) or `false` (or 0).

The "background" bits of a non-standard length data set are the bits that fall outside of the non-standard length bit field stored on disk. For example, if five bits of an unsigned 16-bit integer data set located in bits 5 to 9 are written to disk with the parameter `fillone` set to `true` (or 1), then when the data is reread into memory bits 0 to 4 and 10 to 15 would be set to 1. If the same 5-bit data was written with a `fillone` value of `false` (or 0), then bits 0 to 4 and 10 to 15 would be set to 0.

The operation on `fillone` is performed before the operation on `ext`. For example, using the `ext` example above, bits 0 to 16 and 26 to 31 will first be set to the background bit value, and then bits 26 to 31 will be set to 1 or 0 based on the value of the 25th bit.

This function corresponds to the `SDsetnbitdataset` in the HDF library C API.

Examples

```
import matlab.io.hdf4.*
sdID = sd.start('myfile.hdf','create');
sdsID = sd.create(sdID,'temperature','int32',[10 20]);
sd.setNBitDataSet(sdsID,6,4,0,0);
data = int32([1:200]);
data = reshape(data,10,20);
sd.writeData(sdsID,[0 0],data);
sd.endAccess(sdsID);
sd.close(sdID);
```

See Also

```
sd.setCompress
```

Purpose Set maximum and minimum range value for data set

Syntax `setRange(sdsID,maxval,minval)`

Description `setRange(sdsID,maxval,minval)` sets the maximum and minimum range values of the data set identified by `sdsID`. These values form the "valid_range" attribute for `sdsID`.

The actual maximum and minimum values of the data set are not computed. The "valid_range" attribute is for informational purposes only.

This function corresponds to the `SDsetrange` function in the HDF library C interface.

Examples

```
import matlab.io.hdf4.*
sdID = sd.start('myfile.hdf','create');
sdsID = sd.create(sdID,'temperature','double',[10 20]);
sd.setDataStrs(sdsID,'Temperature','degrees_celsius','%.2f','');
sd.setRange(sdsID,1000,-273.15);
sd.endAccess(sdsID);
sd.close(sdID);
```

See Also `sd.getRange`

matlab.io.hdf4.sd.start

Purpose Open HDF file and initialize SD interface

Syntax `sdID = start(filename)`
`sdID = start(filename,access)`

Description `sdID = start(filename)` opens the file `filename` in read-only mode. This routine must be called for each file before any other `sd` calls can be made on that file.

`sdID = start(filename,access)` opens the file `filename` with the access mode specified by `access`. This routine must be called before any other SD interface operations can be made on that file. `access` can be one of the following strings:

- 'read'
- 'write'
- 'create'

`access` defaults to 'read' if not supplied.

This function corresponds to the `SDstart` function in the HDF library C API.

Examples

```
import matlab.io.hdf4.*
sdID = sd.start('sd.hdf');
sd.close(sdID);
```

See Also `sd.close`

Purpose

Write chunk to data set

Syntax

```
writeChunk(sdsID,origin,dataChunk)
```

Description

`writeChunk(sdsID,origin,dataChunk)` writes an entire chunk of data to the data set identified by `sdsID`. The `origin` input specifies the location of the chunk in chunking coordinates, not in data set coordinates.

This function corresponds to the `SDwritechunk` function in the HDF library C API, but because MATLAB uses FORTRAN-style ordering, the `origin` parameter is reversed with respect to the C library API.

Examples

Write to a 2D chunked and compressed data set. The chunked layout constitutes a 10-by-5 grid.

```
import matlab.io.hdf4.*
sdID = sd.start('myfile.hdf','create');
sdsID = sd.create(sdID,'temperature','double',[100 50]);
sd.setChunk(sdsID,[10 10],'deflate',5);
for j = 0:9
    for k = 0:4
        origin = [j k];
        data = (1:100) + k*1000 + j*10000;
        data = reshape(data,10,10);
        sd.writeChunk(sdsID,origin,data);
    end
end
sd.endAccess(sdsID);
sd.close(sdID);
```

See Also

`sd.readChunk` | `sd.writeData`

matlab.io.hdf4.sd.writeData

Purpose Write to data set

Syntax `writeData(sdsID,data)`
`writeData(sdsID,start,data)`
`writeData(sdsID,start,stride,data)`

Description `writeData(sdsID,data)` writes all the data to the data set identified by `sdsID`.

`writeData(sdsID,start,data)` writes a contiguous hyperslab to the data set. `start` specifies the zero-based starting index. The number of values along each dimension is inferred from the size of `data`.

`writeData(sdsID,start,stride,data)` writes a strided hyperslab of data to a grid datafield. The number of elements to write along each dimension is inferred either from the size of `data` or from the data set itself.

`start` and `stride` use zero-based indexing.

This function corresponds to the `SDreadchunk` function in the HDF library C API, but because MATLAB uses FORTRAN-style ordering, the `start` and `stride` parameters are reversed with respect to the C library API.

Examples Write to a 2D data set.

```
import matlab.io.hdf4.*
sdID = sd.start('myfile.hdf','create');
sdsID = sd.create(sdID,'temperature','double',[10 20]);
data = rand(10,20);
sd.writeData(sdsID,[0 0],data);
sd.endAccess(sdsID);
sd.close(sdID);
```

Write to a 2D unlimited data set.

```
import matlab.io.hdf4.*
sdID = sd.start('myfile.hdf','create');
sdsID = sd.create(sdID,'temperature','double',[10 0]);
data = rand(10,20);
sd.writeData(sdsID,[0 0],data);
data = rand(10,30);
sd.writeData(sdsID,[0 20],data);
sd.endAccess(sdsID);
sd.close(sdID);
```

See Also

`sd.readData`

Purpose Low-level access to HDF-EOS grid data

Description To use these MATLAB functions, you must be familiar with the HDF-EOS library C interface. In most cases, the syntax of the MATLAB function is similar to the syntax of the corresponding HDF-EOS library function. The functions are implemented as the package `matlab.io.hdfeos.gd`. To use this package, prefix the function name with a package path, or use the import function to add the package to the current import list, prior to calling the function, for example,

```
import matlab.io.hdfeos.*  
gfid = gd.open(filename, 'read');
```

Access

| | |
|---|---------------------------|
| <code>matlab.io.hdfeos.gd.attach</code> | Attach to existing grid |
| <code>matlab.io.hdfeos.gd.close</code> | Close HDF-EOS grid file |
| <code>matlab.io.hdfeos.gd.detach</code> | Detach from existing grid |
| <code>matlab.io.hdfeos.gd.open</code> | Open grid file |

Definition

| | |
|---|---------------------------------------|
| <code>matlab.io.hdfeos.gd.create</code> | Create new grid structure |
| <code>matlab.io.hdfeos.gd.defComp</code> | Set grid field compression |
| <code>matlab.io.hdfeos.gd.defDim</code> | Define new dimension within grid |
| <code>matlab.io.hdfeos.gd.defField</code> | Define new data field within grid |
| <code>matlab.io.hdfeos.gd.defOrigin</code> | Define origin of pixels in grid |
| <code>matlab.io.hdfeos.gd.defPixReg</code> | Define pixel registration within grid |
| <code>matlab.io.hdfeos.gd.defProj</code> | Define grid projection |
| <code>matlab.io.hdfeos.gd.writeBlkSomOff</code> | Write Block SOM offset |

Basic I/O

| | |
|----------------------------------|------------------------------------|
| matlab.io.hdfEOS.gd.getFillValue | Fill value for specified field |
| matlab.io.hdfEOS.gd.readAttr | Read grid attribute |
| matlab.io.hdfEOS.gd.readField | Read data from grid field |
| matlab.io.hdfEOS.gd.setFillValue | Set fill value for specified field |
| matlab.io.hdfEOS.gd.writeAttr | Write grid attribute |
| matlab.io.hdfEOS.gd.writeField | Write data to grid field |

Inquiry

| | |
|--------------------------------------|---|
| matlab.io.hdfEOS.gd.compInfo | Compression information for field |
| matlab.io.hdfEOS.gd.dimInfo | Length of dimension |
| matlab.io.hdfEOS.gd.fieldInfo | Information about data field |
| matlab.io.hdfEOS.gd.gridInfo | Position and size of grid |
| matlab.io.hdfEOS.gd.inqAttrs | Names of grid attributes |
| matlab.io.hdfEOS.gd.inqDims | Information about dimensions defined in grid |
| matlab.io.hdfEOS.gd.inqFields | Information about data fields defined in grid |
| matlab.io.hdfEOS.gd.inqGrid | Names of grids in file |
| matlab.io.hdfEOS.gd.nEntries | Number of specified objects |
| matlab.io.hdfEOS.gd.originInfo | Origin code |
| matlab.io.hdfEOS.gd.pixRegInfo | Pixel registration code |
| matlab.io.hdfEOS.gd.projInfo | GCTP projection information about grid |
| matlab.io.hdfEOS.gd.readBlkSomOffset | Read Block SOM offset |

Subsetting

| | |
|-----------------------------------|---|
| matlab.io.hdfEOS.gd.defBoxRegion | Define region of interest by latitude and longitude |
| matlab.io.hdfEOS.gd.defVrtRegion | Define vertical subset region |
| matlab.io.hdfEOS.gd.extractRegion | Read region of interest from field |
| matlab.io.hdfEOS.gd.getPixels | Pixel rows and columns for latitude/longitude pairs |
| matlab.io.hdfEOS.gd.getPixValues | Read data values for specified pixels |
| matlab.io.hdfEOS.gd.regionInfo | Information about subsetted region |

Tiling

| | |
|---------------------------------|--|
| matlab.io.hdfEOS.gd.defTile | Define tiling parameters |
| matlab.io.hdfEOS.gd.readTile | Read single tile of data from field |
| matlab.io.hdfEOS.gd.setTileComp | Set tiling and compression for field with fill value |
| matlab.io.hdfEOS.gd.tileInfo | Tile size of grid field |
| matlab.io.hdfEOS.gd.writeTile | Write tile to field |

Utility

| | |
|---------------------------|--|
| matlab.io.hdfEOS.gd.ij2ll | Convert row and column space to latitude and longitude |
| matlab.io.hdfEOS.gd.ll2ij | Convert latitude and longitude to row and column space |

matlab.io.hdfEOS.gd.sphereCodeToName Name corresponding to GCTP
sphere code

matlab.io.hdfEOS.gd.sphereNameToCode Numeric GCTP code
corresponding to sphere name

matlab.io.hdfeos.gd.attach

Purpose Attach to existing grid

Syntax `gridID = attach(gfID,gridName)`

Description `gridID = attach(gfID,gridName)` attaches to the grid dataset identified by `gridName` in the file identified by `gfID`. The `gridID` output is the identifier for the grid dataset.

This function corresponds to the `GDattach` function in the HDF-EOS library C API.

Examples Attach to the grid named 'PolarGrid' in the file 'grid.hdf'.

```
import matlab.io.hdfeos.*
gfID = gd.open('grid.hdf');
gridID = gd.attach(gfID,'PolarGrid');
gd.detach(gridID);
gd.close(gfID);
```

See Also `gd.detach` | `gd.readField` | `gd.inqGrid`

Purpose Close HDF-EOS grid file

Syntax `close(gfID)`

Description `close(gfID)` closes an HDF-EOS grid file identified by `gfID`.
This function corresponds to the `GDClose` function in the HDF-EOS library C API.

Examples

```
import matlab.io.hdfeos.*  
gfID = gd.open('grid.hdf');  
gd.close(gfID);
```

See Also `gd.open` | `gd.create`

matlab.io.hdfEOS.gd.compInfo

Purpose Compression information for field

Syntax `[compCode,parms] = compInfo(gridID,fieldname)`

Description `[compCode,parms] = compInfo(gridID,fieldname)` returns the compression code and compression parameters for a given field. Refer to `gd.defComp` for a description of various compression schemes and parameters.

This function corresponds to the `GDcompinfo` function in the HDF-EOS library C API.

Examples Define a 'Pressure' field with run-length encoding compression and an 'Opacity' field with gzip compression.

```
import matlab.io.hdfEOS.*
gfid = gd.open('grid.hdf');
gridID = gd.attach(gfid, 'PolarGrid');
[compCode,compParms] = gd.compInfo(gridID, 'ice_temp');
gd.detach(gridID);
gd.close(gfid);
```

See Also `gd.defComp`

Purpose

Create new grid structure

Syntax

```
gridID = create(gfID,gridName,xdim,ydim,upLeft,lowRight)
```

Description

`gridID = create(gfID,gridName,xdim,ydim,upLeft,lowRight)` creates a new grid structure where `gfID` is the grid file identifier. `gridName` is the name of the new grid. `xdim` and `ydim` define the size of the grid. `upLeft` is a two-element vector containing the location of the upper left pixel, and `lowRight` is a two-element vector containing the location of the lower right pixel.

Note `upLeft` and `lowRight` are in units of meters for all GCTP projections other than the geographic and bcea projections, which should have units of packed degrees.

Note For certain projections, `upLeft` and `lowRight` can be given as `[]`.

- Polar Stereographic projection of an entire hemisphere.
 - Goode Homolosine projection of the entire globe.
 - Lambert Azimuthal entire polar or equatorial projection.
-

Note MATLAB uses Fortran-style ordering, but the HDF-EOS library uses C-style ordering.

This function corresponds to the `GDcreate` function in the HDF-EOS library C API.

matlab.io.hdfEOS.gd.create

Examples

Create a polar stereographic grid of the northern hemisphere.

```
import matlab.io.hdfEOS.*
gfid = gd.open('myfile.hdf','create');
gridID = gd.create(gfid, 'PolarGrid', 100, 100, [], []);
gd.detach(gridID);
gd.close(gfid);
```

Create a UTM grid bounded by 54 E to 60 E longitude and 20 N to 30 N latitude. Divide the grid into 120 bins along the x-axis and 200 bins along the y-axis.

```
import matlab.io.hdfEOS.*
gfid = gd.open('myfile.hdf','create');
uplft = [210584.50041 3322395.95445];
lowrgt = [813931.10959 2214162.53278];
gridID = gd.create(gfid, 'UTMGrid', 120, 200, uplft, lowrgt);
gd.detach(gridID);
gd.close(gfid);
```

See Also

[gd.detach](#) | [gd.defProj](#) | [gd.gridInfo](#)

Purpose

Define region of interest by latitude and longitude

Syntax

```
regionID = defBoxRegion(gridID,cornerLat,cornerLon)
```

Description

`regionID = defBoxRegion(gridID,cornerLat,cornerLon)` defines a latitude-longitude box region as a subset region for a grid. `regionID` can be used to read all the entries of a data field within the region.

This function corresponds to the `GDdefboxregion` function in the HDF-EOS library C API.

Examples

Define a region of interest between 20 and 50 degrees latitude and between -90 and -60 degrees longitude.

```
import matlab.io.hdfeos.*
gfid = gd.open('grid.hdf','read');
gridID = gd.attach(gfid,'PolarGrid');
cornerlat = [20 50];
cornerlon = [-90 -60];
regionID = gd.defBoxRegion(gridID,cornerlat,cornerlon);
data = gd.extractRegion(gridID,regionID,'ice_temp');
gd.detach(gridID);
gd.close(gfid);
```

See Also

`gd.extractRegion`

Purpose Set grid field compression

Syntax `defComp(gridID,compscheme,compparm)`

Description `defComp(gridID,compscheme,compparm)` sets the HDF field compression for subsequent field definitions. The compression scheme does not apply to one-dimensional fields. `compscheme` can be one of the following strings.

| | |
|-----------|---------------------|
| 'rle' | Run-length encoding |
| 'skphuff' | Skipping Huffman |
| 'deflate' | Gzip deflate |
| 'none' | No compression |

When the compression scheme is 'deflate', `compparm` is the deflate compression level, an integer between 0 and 9. `compparm` can be omitted for the other compression schemes.

If a field is defined with compression, it must be written with a single call to `gd.writeField`. If this is not possible, you should consider using tiling.

This function corresponds to the `GDdefcomp` function in the HDF-EOS library C API.

Examples Create a grid with a polar stereographic Pressure field using run-length encoding, and then an Opacity field with deflate compression.

```
import matlab.io.hdfEOS.*
gfid = gd.open('myfile.hdf','create');
gridID = gd.create(gfid,'PolarGrid',100,100,[],[]);
projparm = zeros(1,13);
projparm(6) = 90000000;
gd.defProj(gridID,'ps',[],'WGS 84',projparm);
dims = { 'XDim', 'YDim' };
gd.defComp(gridID,'rle');
```

```
gd.defField(gridID, 'Pressure', dims, 'float');  
gd.defComp(gridID, 'deflate', 5);  
gd.defField(gridID, 'Opacity', dims, 'float');  
gd.detach(gridID);  
gd.close(gfid);
```

See Also

[gd.defField](#) | [gd.defTile](#)

matlab.io.hdfEOS.gd.defDim

Purpose Define new dimension within grid

Syntax `defDim(gridID,dimname,dimlen)`

Description `defDim(gridID,dimname,dimlen)` defines a new dimension named `dimname` with length `dimlen` in the grid structure identified by `gridID`.
To specify an unlimited dimension, you can use either 0 or 'unlimited' for `dimlen`.

This function corresponds to the `GDdefdim` function in the HDF-EOS library C API.

Examples Define a dimension 'Band' with length of 15 and an unlimited dimension 'Time'.

```
import matlab.io.hdfEOS.*
gfid = gd.open('myfile.hdf','create');
gridID = gd.create(gfid,'PolarGrid',100,100,[],[]);
gd.defDim(gridID,'Band',15);
gd.defDim(gridID,'Time',0);
gd.detach(gridID);
gd.close(gfid);
```

See Also `gd.defField` | `gd.dimInfo`

Purpose

Define new data field within grid

Syntax

```
defField(gridID,fieldname,dimlist,dtype)
defField(gridID,fieldname,dimlist,dtype,mergeCode)
```

Description

`defField(gridID,fieldname,dimlist,dtype)` defines data fields for a grid specified by `gridID`. The `fieldname` input is the name of the new field. `dimlist` is a cell array of geolocation dimensions and should be listed in FORTRAN-style order, that is, the fastest varying dimension should be listed first. `dimlist` can also be a string if there is only one dimension. `dtype` is the data type of the field.

`defField(gridID,fieldname,dimlist,dtype,mergeCode)` defines a data field with a specific merge code. `mergeCode` can be either 'nomerge' or 'automerge'. The `mergeCode` input defaults to 'nomerge' if not provided.

This function corresponds to the `GDdeffield` function in the HDF library C API, but because MATLAB uses FORTRAN-style ordering, the `dimlist` parameter is reversed with respect to the C library API.

Examples

Define a single precision grid field 'Temperature' with dimensions 'XDim' and 'YDim'. Then define a single precision field 'Spectra' with dimensions 'XDim', 'YDim', and 'Bands'.

```
import matlab.io.hdfeos.*
gfid = gd.open('myfile.hdf','create');
xdim = 120; ydim = 200;
gridID = gd.create(gfid,'geo',xdim,ydim,[],[]);
gd.defProj(gridID,'geo',[],[],[]);
dimlist = {'XDim','YDim'};
gd.defField(gridID,'Temperature',dimlist,'single');
gd.defDim(gridID,'Bands',3);
dimlist = {'XDim','YDim','Bands'};
gd.defField(gridID,'Spectra',dimlist,'uint8');
gd.detach(gridID);
gd.close(gfid);
```

See Also

[gd.create](#) | [gd.defDim](#)

Purpose Define origin of pixels in grid

Syntax `defOrigin(gridID,originCode)`

Description `defOrigin(gridID,originCode)` defines the origin of pixels in a grid. `gridID` is the identifier of the grid, and `originCode` can be one of the following four strings.

| | |
|------|-------------|
| 'ul' | Upper-left |
| 'ur' | Upper-right |
| 'll' | Lower-left |
| 'lr' | Lower-right |

You can select any corner of the grid pixel as the origin. If this routine is not invoked, the grid defaults to using the upper-left corner for the origin.

This function corresponds to the `GDdeforigin` function in the HDF-EOS library C API.

Examples Create a polar stereographic grid with the origin of the grid pixel in the lower right corner.

```
import matlab.io.hdfeos.*
gfid = gd.open('myfile.hdf','create');
gridID = gd.create(gfid,'PolarGrid',100,100,[],[]);
projparm = zeros(1,13);
projparm(6) = 90000000;
gd.defProj(gridID,'ps',[],'WGS 84',projparm);
gd.defOrigin(gridID,'lr');
gd.detach(gridID);
gd.close(gfid);
```

See Also `gd.originInfo` | `gd.defPixReg`

Purpose Define pixel registration within grid

Syntax `defPixReg(gridID,pixRegCode)`

Description `defPixReg(gridID,pixRegCode)` defines whether the pixel center or pixel corner is used when requesting the location (longitude and latitude) of a given pixel. `pixRegCode` can be one of the following strings.

| | |
|----------|----------------------|
| 'center' | Center of pixel cell |
| 'corner' | Corner of pixel cell |

If this routine is not invoked, the pixel registration is 'center'.

This function corresponds to the `GDdefpixreg` function in the HDF-EOS library.

Examples Define a grid with pixel registration in the center.

```
import matlab.io.hdfEOS.*
gfid = gd.open('myfile.hdf','create');
gridID = gd.create(gfid,'PolarGrid',100,100,[],[]);
projparm = zeros(1,13);
projparm(6) = 90000000;
gd.defProj(gridID,'ps',[],'WGS 84',projparm);
gd.defPixReg(gridID,'corner');
gd.detach(gridID);
gd.close(gfid);
```

See Also `gd.defOrigin` | `gd.pixRegInfo`

Purpose Define grid projection

Syntax `defProj(gridID,projCode,zoneCode,sphereCode,projParm)`

Description `defProj(gridID,projCode,zoneCode,sphereCode,projParm)` defines a GCTP projection on the grid specified by `gridID`. The `projCode` argument can be one of the following strings.

| | |
|-----------------------|---------------------------------|
| <code>'geo'</code> | Geographic |
| <code>'utm'</code> | Universal Transverse Mercator |
| <code>'albers'</code> | Albers Canonical Equal Area |
| <code>'lamcc'</code> | Lambert Conformal Conic |
| <code>'ps'</code> | Polar Stereographic |
| <code>'polyc'</code> | Polyconic |
| <code>'tm'</code> | Transverse Mercator |
| <code>'lamaz'</code> | Lambert Azimuthal Equal Area |
| <code>'snsoid'</code> | Sinusoidal |
| <code>'hom'</code> | Hotine Oblique Mercator |
| <code>'som'</code> | Space Oblique Mercator |
| <code>'good'</code> | Interrupted Goode Homolosine |
| <code>'cea'</code> | Cylindrical Equal Area |
| <code>'bcea'</code> | Behrmann Cylindrical Equal Area |
| <code>'isinus'</code> | Integerized Sinusoidal |

If `projCode` is `'geo'`, then `zoneCode`, `sphereCode`, and `projParm` should be specified as `[]`. Any other values for these parameters are ignored.

`zoneCode` is the Universal Transverse Mercator zone code. It should be specified as `-1` for other projections.

sphereCode is the name of the GCTP spheroid or the corresponding numeric code.

projParm is a vector of up to 13 elements containing projection-specific parameters. For more details about projCode, zoneCode, sphereCode, and projParm, see Chapter 6 of HDF-EOS Library Users Guide for the ECS Project, Volume 1: Overview and Examples.

This function corresponds to the GDdefproj function in the HDF library C API.

Examples

Create a UTM grid bounded by 54 E to 60 E longitude and 20 N to 30 N latitude (zone 40). Divide the grid into 120 bins along the x-axis and 200 bins along the y-axis.

```
import matlab.io.hdfEOS.*
gfid = gd.open('myfile.hdf','create');
uplft = [210584.50041 3322395.95445];
lowrgt = [813931.10959 2214162.53278];
gridID = gd.create(gfid,'UTMGrid',120,200,uplft,lowrgt);
gd.defProj(gridID,'utm',40,'Clarke 1866',[]);
gd.detach(gridID);
gd.close(gfid);
```

Add a polar stereographic projection of the northern hemisphere with true scale at 90 N, 0 longitude below the pole using the WGS 84 spheroid.

```
import matlab.io.hdfEOS.*
gfid = gd.open('myfile.hdf','create');
gridID = gd.create(gfid,'PolarGrid',100,100,[],[]);
projparm = zeros(1,13);
projparm(6) = 90000000;
gd.defProj(gridID,'ps',[],'WGS 84',projparm);
gd.detach(gridID);
gd.close(gfid);
```

See Also

[gd.projInfo](#) | [gd.create](#) | [gd.sphereCodeToName](#)

matlab.io.hdfEOS.gd.defTile

Purpose Define tiling parameters

Syntax `defTile(gridID,tileDims)`

Description `defTile(gridID,tileDims)` defines tiling dimensions for subsequent field definitions. If `tileDims` is `[]`, then subsequently defined fields will have no tiling.

This function corresponds to the `GDdefTile` function in the HDF-EOS library C API, but because MATLAB uses FORTRAN-style ordering, the `tileDims` parameter is reversed with respect to the C library API.

Examples Define a field with tiling, then a subsequent field with no tiling.

```
import matlab.io.hdfEOS.*
gfid = gd.open('myfile.hdf','create');
gridID = gd.create(gfid,'GeoGrid',120,200,[],[]);
gd.defDim(gridID,'Bands',3);
gd.defProj(gridID,'geo',[],[],[]);
gd.defTile(gridID,[30 50 1]);
dimlist = {'XDim','YDim','Bands'};
gd.defField(gridID,'Spectra',dimlist,'float');
gd.defTile(gridID,[]);
dimlist = {'XDim','YDim'};
gd.defField(gridID,'Temperature',dimlist,'int32');
gd.detach(gridID);
gd.close(gfid);
```

See Also `gd.tileInfo` | `gd.defField`

Purpose

Define vertical subset region

Syntax

```
out_RID = defVrtRegion(gridID,regionID,vobj,vRange)
```

Description

`out_RID = defVrtRegion(gridID,regionID,vobj,vRange)` defines a vertical subset region and can be used on either a monotonic field or contiguous elements of a dimension.

`regionID` should be 'noprevious' if no prior subsetting has occurred. Otherwise it should be a value as returned from a previous subsetting routine.

`vobj` is the name of either the dimension or field to subset. If `vobj` is a dimension, it should be prefixed with 'DIM:'.

`vRange` is the minimum and maximum range for the vertical subset.

This function corresponds to the `GDdefvrtregion` function in the HDF-EOS library C API.

Examples

```
import matlab.io.hdfEOS.*
gfid = gd.open('grid.hdf');
gridID = gd.attach(gfid,'PolarGrid');
range = [333 667];
regionID = gd.defVrtRegion(gridID,'noprevious','Height',range);
data = gd.extractRegion(gridID,regionID,'pressure');
gd.detach(gridID);
gd.close(gfid);
```

```
import matlab.io.hdfEOS.*
gfid = gd.open('grid.hdf');
gridID = gd.attach(gfid,'PolarGrid');
range = [3 5];
regionID = gd.defVrtRegion(gridID,'noprevious','DIM:Height',range);
data = gd.extractRegion(gridID,regionID,'pressure');
gd.detach(gridID);
gd.close(gfid);
```

matlab.io.hdfeos.gd.defVrtRegion

See Also

`gd.extractRegion`

| | |
|--------------------|---|
| Purpose | Detach from existing grid |
| Syntax | <code>detach(gridID)</code> |
| Description | <code>detach(gridID)</code> detaches from the grid identified by <code>gridID</code> .
This function corresponds to the <code>GDdetach</code> function in the HDF-EOS library C API. |
| Examples | <pre>import matlab.io.hdfeos.* gfID = gd.open('grid.hdf'); gridID = gd.attach(gfID, 'PolarGrid'); gd.detach(gridID); gd.close(gfID);</pre> |
| See Also | <code>gd.attach</code> |

matlab.io.hdfEOS.gd.dimInfo

Purpose Length of dimension

Syntax `dimlen = diminfo(gridID,dimname)`

Description `dimlen = diminfo(gridID,dimname)` retrieves the length of the specified user-defined dimension.

Please note that the two extents used to create the grid are not considered user-defined dimensions. To retrieve the length of XDim and YDim, use `gd.gridInfo`. This function corresponds to the `GDdiminfo` function in the HDF-EOS library C API.

Examples Inquire about a 'Bands' dimension.

```
import matlab.io.hdfEOS.*
gfid = gd.open('grid.hdf');
gridID = gd.attach(gfid,'PolarGrid');
dimlen = gd.dimInfo(gridID,'Height');
gd.detach(gridID);
gd.close(gfid);
```

See Also `gd.defDim` | `gd.gridInfo`

| | |
|--------------------|--|
| Purpose | Read region of interest from field |
| Syntax | <code>data = extractRegion(gridID,regionID,fieldname)</code> |
| Description | <p><code>data = extractRegion(gridID,regionID,fieldname)</code> extract data from a subsetted region.</p> <p>This routine corresponds to the <code>Gdextractregion</code> function in the HDF-EOS library C API.</p> |
| Examples | <p>Define and extract a region of interest between 20 and 50 degrees latitude and between -90 and -60 degrees longitude.</p> <pre>import matlab.io.hdfeos.* gfid = gd.open('grid.hdf','read'); gridID = gd.attach(gfid,'PolarGrid'); cornerlat = [20 50]; cornerlon = [-90 -60]; regionID = gd.defBoxRegion(gridID,cornerlat,cornerlon); data = gd.extractRegion(gridID,regionID,'ice_temp'); gd.detach(gridID); gd.close(gfid);</pre> |
| See Also | <code>gd.defBoxRegion</code> <code>gd.defVrtRegion</code> |

matlab.io.hdfeos.gd.fieldInfo

Purpose Information about data field

Syntax `[dims,ntype,dimlist] = fieldInfo(gridID,fieldname)`

Description `[dims,ntype,dimlist] = fieldInfo(gridID,fieldname)` returns information about a specific geolocation or data field in the grid. `dims` is a vector containing the dimension sizes of the field. `ntype` is a string containing the HDF number type of the field. `dimlist` is a cell array of strings containing the list of dimension names.

This function corresponds to the `Gdfieldinfo` function in the HDF-EOS library C API, but because MATLAB uses FORTRAN-style ordering, the `dimlist` parameter is reversed with respect to the C library API.

Examples

```
import matlab.io.hdfeos.*
gfid = gd.open('grid.hdf','read');
gridID = gd.attach(gfid,'PolarGrid');
[dims,ntype,dimlist] = gd.fieldInfo(gridID,'ice_temp');
gd.detach(gridID);
gd.close(gfid);
```

See Also `gd.defField`

Purpose Fill value for specified field

Syntax `fillvalue = getFillValue(gridID,fieldname)`

Description `fillvalue = getFillValue(gridID,fieldname)` retrieves the fill value for the specified field.

This function corresponds to the `GDgetfillvalue` function in the HDF-EOS library C API.

Examples Return the fill value for the 'ice_temp' field in the 'PolarGrid' grid.

```
import matlab.io.hdfeos.*
gfid = gd.open('grid.hdf');
gridID = gd.attach(gfid, 'PolarGrid');
fillvalue = gd.getFillValue(gridID, 'ice_temp');
gd.detach(gridID);
gd.close(gfid);
```

See Also `gd.setFillValue`

matlab.io.hdfeos.gd.getPixels

Purpose Pixel rows and columns for latitude/longitude pairs

Syntax `[row,col] = getPixels(gridID,lat,lon)`

Description `[row,col] = getPixels(gridID,lat,lon)` converts latitude/longitude pairs into zero-based pixel row and column coordinates. The origin is the upper left-hand corner of the grid pixel. If the latitude/longitude pairs are outside the grid, then row and col are -1.

This function corresponds to the GDgetpixels function in the HDF-EOS library C API.

Examples

```
import matlab.io.hdfeos.*
gfid = gd.open('grid.hdf','read');
gridID = gd.attach(gfid,'PolarGrid');
cornerlat = [20 50];
cornerlon = [-90 -60];
[row,col] = gd.getPixels(gridID,cornerlat,cornerlon);
gd.detach(gridID);
gd.close(gfid);
```

See Also `gd.getPixValues`

Purpose

Read data values for specified pixels

Syntax

```
data = getPixValues(gridID,rows,cols,fieldname)
```

Description

`data = getPixValues(gridID,rows,cols,fieldname)` reads data values for the pixels specified by the zero-based `rows` and `cols` coordinates. All entries along the non-geographic dimensions, i.e. NOT `XDim` and `YDim`, are returned.

This function corresponds to the `GDgetpixvalues` function in the HDF-EOS library C API.

Examples

Read the grid field's corner values.

```
import matlab.io.hdfEOS.*
gfid = gd.open('grid.hdf','read');
gridID = gd.attach(gfid,'PolarGrid');
rows = [0 99 99 0];
cols = [0 0 99 99];
data = gd.getPixValues(gridID,rows,cols,'ice_temp');
gd.detach(gridID);
gd.close(gfid);
```

See Also

[gd.getPixels](#) | [gd.readField](#) | [gd.defBoxRegion](#) | [gd.extractRegion](#)

matlab.io.hdfeos.gd.gridInfo

Purpose Position and size of grid

Syntax `[xDim,yDim,upLeft,lowRight] = gridInfo(gridID)`

Description `[xDim,yDim,upLeft,lowRight] = gridInfo(gridID)` returns the size of a grid as well as the upper left and lower right corners of the grid.

Note `upLeft` and `lowRight` are in units of meters for all GCTP projections other than the geographic and bcea projections, which will have units of packed degrees.

This function corresponds to the `GDgridinfo` function in the HDF-EOS library C API.

Examples

```
import matlab.io.hdfeos.*
gfid = gd.open('grid.hdf');
gridID = gd.attach(gfid,'PolarGrid');
[xdimsize,ydimsize,upleft,lowright] = gd.gridInfo(gridID);
gd.detach(gridID);
gd.close(gfid);
```

See Also `gd.create`

| | |
|--------------------|---|
| Purpose | Convert row and column space to latitude and longitude |
| Syntax | <code>[lat,lon] = ij2ll(gridID,row,col)</code> |
| Description | <p><code>[lat,lon] = ij2ll(gridID,row,col)</code> converts a grid's row and column coordinates to latitude and longitude in decimal degrees.</p> <p>row and col are zero-based and defined such that col increases monotonically with the XDim dimension and row increases monotonically with the YDim dimension in the HD-EOS library.</p> <p>This routine corresponds to the GDij2ll function in the HDF-EOS C API.</p> |
| Examples | <pre>import matlab.io.hdfeos.* gfid = gd.open('grid.hdf'); gridID = gd.attach(gfid,'PolarGrid'); [xdim,ydim] = gd.gridInfo(gridID); r = 0:(xdim-1); c = 0:(ydim-1); [Col,Row] = meshgrid(c,r); [lat,lon] = gd.ij2ll(gridID,Row,Col); gd.detach(gridID); gd.close(gfid);</pre> |
| See Also | <code>gd.ll2ij</code> <code>gd.readField</code> |

matlab.io.hdfEOS.gd.inqAttrs

| | |
|--------------------|--|
| Purpose | Names of grid attributes |
| Syntax | <code>attrList = inqAttrs(gridID)</code> |
| Description | <code>attrList = inqAttrs(gridID)</code> returns the list of grid attribute names. <code>attrList</code> is a cell array.

This function corresponds to the <code>GDinqattrs</code> function in the HDF-EOS library C API. |
| Examples | <pre>import matlab.io.hdfEOS.* gfid = gd.open('grid.hdf'); gridID = gd.attach(gfid,'PolarGrid'); attrList = gd.inqAttrs(gridID); gd.detach(gridID); gd.close(gfid);</pre> |
| See Also | <code>gd.readAttr</code> <code>gd.writeAttr</code> |

| | |
|--------------------|---|
| Purpose | Information about dimensions defined in grid |
| Syntax | <code>[dimnames,dimlens] = inqDims(gridID)</code> |
| Description | <p><code>[dimnames,dimlens] = inqDims(gridID)</code> returns the names of the dimensions <code>dimnames</code> in a cell array and their respective lengths <code>dimlens</code>. This does not include the grid extent dimensions <code>XDim</code> and <code>YDim</code>.</p> <p>This function corresponds to the <code>GDinqdims</code> function in the HDF-EOS library C API, but because MATLAB uses FORTRAN-style ordering, the <code>dimnames</code> and <code>dimlens</code> parameters are reversed with respect to the C library API.</p> |
| Examples | <pre>import matlab.io.hdfEOS.* gfid = gd.open('grid.hdf','read'); gridID = gd.attach(gfid,'PolarGrid'); [dims,dimlens] = gd.inqDims(gridID); gd.detach(gridID); gd.close(gfid);</pre> |
| See Also | <code>gd.defDim</code> |

matlab.io.hdfEOS.gd.inqFields

Purpose Information about data fields defined in grid

Syntax [fldList,fldRank,fldType] = inqFields(gridID)

Description [fldList,fldRank,fldType] = inqFields(gridID) returns the list of fields fldList as a cell array. fldRank contains the rank of each data field. fldType is a cell array containing the data type of each data field.

This function corresponds to the GDinqfields function in the HDF-EOS library C API.

Examples

```
import matlab.io.hdfEOS.*
gfid = gd.open('grid.hdf');
gridID = gd.attach(gfid,'PolarGrid');
[fldlist,fldranks,fldtypes] = gd.inqFields(gridID);
gd.detach(gridID);
gd.close(gfid);
for j = 1:numel(fldranks)
    fprintf('%s: Rank %d, datatype %s\n', fldlist{j},fldranks(j),fldtypes{j})
end
```

See Also gd.defField

Purpose Names of grids in file

Syntax `grids = inqGrid(filename)`

Description `grids = inqGrid(filename)` returns the names of all grids in the given file. `grids` is a cell array.

This function corresponds to the `GDinqgrid` function in the HDF-EOS library C API.

Examples

```
import matlab.io.hdfeos.*
grids = gd.inqGrid('grid.hdf');
```

See Also `gd.create` | `sw.inqSwath`

matlab.io.hdfEOS.gd.ll2ij

Purpose Convert latitude and longitude to row and column space

Syntax `[row,col] = ll2ij(gridID,lat,lon)`

Description `[row,col] = ll2ij(gridID,lat,lon)` converts latitude and longitude coordinates to a pre-defined grid's row and column coordinates.

`row` and `col` are zero-based and defined such that `col` increases monotonically with the XDim dimension and `row` increases monotonically with the YDim dimension in the HD-EOS library.

This routine corresponds to the GD112ij function in the HDF-EOS C API.

Examples

```
import matlab.io.hdfEOS.*
gfid = gd.open('grid.hdf');
gridID = gd.attach(gfid,'PolarGrid');
lat = [46 46 42 42];
lon = [-71 -67 -67 -71];
[row,col] = gd.ll2ij(gridID,lat,lon);
gd.detach(gridID);
gd.close(gfid);
```

See Also `gd.ij2ll`

Purpose Number of specified objects

Syntax `nentries = nEntries(gridID,entType)`

Description `nentries = nEntries(gridID,entType)` returns the number of specified objects in a grid. `entType` can be either `'dims'` or `'fields'`.

This function corresponds to the `GDnentries` function in the HDF-EOS library C API.

Examples

```
import matlab.io.hdfeos.*
fid = gd.open('grid.hdf');
gridID = gd.attach(fid,'PolarGrid');
ndims = gd.nEntries(gridID,'dims');
nfls = gd.nEntries(gridID,'fields');
gd.detach(gridID);
gd.close(fid);
fprintf('The number of dimensions is %d.\n', ndims);
fprintf('The number of fields is %d.\n', nfls);
```

See Also `gd.inqGrid`

matlab.io.hdfeos.gd.open

Purpose Open grid file

Syntax `gfid = open(filename,access)`

Description `gfid = open(filename,access)` opens or creates an HDF-EOS grid file identified by `filename` and returns a file ID. `access` can be one of the following string values:

| | |
|-----------------------|--|
| <code>'read'</code> | Read-only |
| <code>'rdwr'</code> | Read-write |
| <code>'create'</code> | Creates a file, deleting it if it already exists |

If `access` is not provided, it defaults to `'read'`.

This function corresponds to the `GDopen` function in the HDF-EOS library C API.

Examples

```
import matlab.io.hdfeos.*
gfid = gd.open('grid.hdf');
gd.close(gfid);
```

See Also `gd.attach` | `gd.close`

Purpose Origin code

Syntax `originCode = originInfo(gridID)`

Description `originCode = originInfo(gridID)` retrieves the origin code for the grid specified by `gridID`. The `originCode` output is one of the following four string values.

| | |
|------|-------------|
| 'ul' | Upper-left |
| 'ur' | Upper-right |
| 'll' | Lower-left |
| 'lr' | Lower-right |

This function corresponds to the `GDorigininfo` routine in the HDF-EOS library.

Examples

```
import matlab.io.hdfeos.*
gfid = gd.open('grid.hdf');
gridID = gd.attach(gfid, 'PolarGrid');
origin = gd.originInfo(gridID);
gd.detach(gridID);
gd.close(gfid);
```

See Also `gd.defOrigin`

matlab.io.hdfEOS.gd.pixRegInfo

Purpose Pixel registration code

Syntax `pixRegCode = pixRegInfo(gridID)`

Description `pixRegCode = pixRegInfo(gridID)` retrieve the pixel registration code for the grid identified by `gridID`. The `pixRegCode` output can be one of the following strings.

| | |
|----------|----------------------|
| 'center' | Center of pixel cell |
| 'corner' | Corner of pixel cell |

This function corresponds to the `GDpixreginfo` routine in the HDF-EOS library.

Examples

```
import matlab.io.hdfEOS.*
gfid = gd.open('grid.hdf');
gridID = gd.attach(gfid, 'PolarGrid');
code = gd.pixRegInfo(gridID);
gd.detach(gridID);
gd.close(gfid);
```

See Also `gd.defPixReg`

Purpose

GCTP projection information about grid

Syntax

```
[projCode,zoneCode,sphereName,projParm] = projInfo(gridID)
```

Description

[projCode,zoneCode,sphereName,projParm] = projInfo(gridID) returns the GCTP projection code, zone code, spheroid, and projection parameters for the grid identified by gridID.

zoneCode is -1 if projCode is anything other than 'UTM'.

This function corresponds to the GDprojinfo function in the HDF-EOS library C API.

For details about the GCTP projection code, zone code, spheroid code, and projection parameters, please consult the HDF-EOS User's Guide.

Examples

```
import matlab.io.hdfEOS.*
fid = gd.open('grid.hdf');
gridID = gd.attach(fid,'PolarGrid');
[projCode,zoneCode,sphereCode,projParm] = gd.projInfo(gridID);
gd.detach(gridID);
gd.close(fid);
```

See Also

gd.defProj | gd.sphereNameToCode | gd.sphereCodeToName

matlab.io.hdfEOS.gd.readAttr

Purpose Read grid attribute

Syntax data = readAttr(gridID,attrname)

Description data = readAttr(gridID,attrname) reads a grid attribute.
This function corresponds to the GDreadattr function in the HDF-EOS library C API.

Examples

```
import matlab.io.hdfEOS.*
gfid = gd.open('grid.hdf','read');
gridID = gd.attach(gfid,'PolarGrid');
data = gd.readAttr(gridID,'creation_date');
gd.detach(gridID);
gd.close(gfid);
```

See Also gd.writeAttr

Purpose

Read Block SOM offset

Syntax

```
offset = readBlkSomOffset(GID)
```

Description

`offset = readBlkSomOffset(GID)` reads the block SOM offset values, in pixels, from a standard SOM (Space Oblique Mercator) projection. `offset` is a vector of offset values for SOM projection data. This routine can only be used with grids that use the SOM projection.

This function corresponds to the `GDbkSOMoffset` function in the HDF-EOS library C API.

Examples

```
import matlab.io.hdfeos.*
gfid = gd.open('myfile.hdf','create');
lowright = [30521379.68485 1152027.64253];
upleft = [-11119487.42844 8673539.24806];
gridID = gd.create(gfid,'SOM',120,60,upleft,lowright);
projparm(1) = 6378137;
projparm(2) = 0.006694348;
projparm(4) = 98096360; % 98.161 in DDDMMMSSSS
projparm(5) = 87069061; % 87.112 in DDDMMMSSSS
projparm(9) = 0.068585416*1440;
projparm(10) = 0.0;
projparm(12) = 6;
gd.defProj(gridID,'som',[],[],projparm);
gd.writeBlkSomOffset(gridID,[5 10 12 8 2]);
gd.detach(gridID);
gd.close(gfid);
gfid = gd.open('myfile.hdf');
gridID = gd.attach(gfid,'SOM');
blk = gd.readBlkSomOffset(gridID);
gd.detach(gridID);
gd.close(gfid);
```

See Also

`gd.writeBlkSomOffset`

matlab.io.hdfEOS.gd.readField

Purpose Read data from grid field

Syntax

```
data = readField(gridID,fieldname)
data = readField(gridID,fieldname,start,count)
data = readField(gridID,fieldname,start,count,stride)
[data,lat,lon] = readField( ___ )
```

Description

`data = readField(gridID,fieldname)` reads the entire grid field identified by `fieldname` in the grid identified by `gridID`.

`data = readField(gridID,fieldname,start,count)` reads a contiguous hyperslab of data from the field. `start` specifies the zero-based starting index of the hyperslab. `count` specifies the number of values to read along each dimension.

`data = readField(gridID,fieldname,start,count,stride)` reads a strided hyperslab of data from the field. `stride` specifies the inter-element spacing along each dimension.

`[data,lat,lon] = readField(___)` reads the data and the associated geo-coordinates from the grid field. This syntax is only allowed when the leading two dimensions of the grid are 'XDim' and 'YDim'.

This function corresponds to the `GDreadfield` function in the HDF-EOS library C API.

Examples Read the data, latitude, and longitude for the 'ice_temp' field.

```
import matlab.io.hdfEOS.*
gfid = gd.open('grid.hdf');
gridID = gd.attach(gfid,'PolarGrid');
[data,lat,lon] = gd.readField(gridID,'ice_temp');
gd.detach(gridID);
gd.close(gfid);
```

Read only the first 4x4 hyperslab of data, latitude, and longitude for the 'ice_temp' field.

```
import matlab.io.hdfEOS.*
gfid = gd.open('grid.hdf');
gridID = gd.attach(gfid, 'PolarGrid');
[data2,lat2,lon2] = gd.readField(gridID, 'ice_temp', [0 0], [4 4]);
gd.detach(gridID);
gd.close(gfid);
```

See Also

`gd.writeField`

matlab.io.hdfeos.gd.readTile

Purpose Read single tile of data from field

Syntax `data = readTile(gridID,fieldname,tileCoords)`

Description `data = readTile(gridID,fieldname,tileCoords)` reads a single of data from a field. If the data is to be read tile by tile, this routine is more efficient than `gd.readField`. In all other cases, use `gd.readField`. The `tileCoords` argument has the form `[rownum colnum]` and is defined in terms of the tile coordinates, not the data elements.

This function corresponds to the `GDreadtile` function in the HDF-EOS library C API, but because MATLAB uses FORTRAN-style ordering, the `tileCoords` parameter is reversed with respect to the C library API.

Examples Define a field with a 2-by-3 tiling scheme.

```
import matlab.io.hdfeos.*
gfid = gd.open('grid.hdf','read');
gridID = gd.attach(gfid,'PolarGrid');
for h = 0:9
    data = gd.readTile(gridID,'pressure',[0 0 h]);
end
gd.detach(gridID);
gd.close(gfid);
```

See Also `gd.writeTile` | `gd.tileInfo`

| | |
|--------------------|---|
| Purpose | Information about subsetted region |
| Syntax | <code>[dims,upLeft,lowRight] = regionInfo(gridID,regionID,fieldname)</code> |
| Description | <p><code>[dims,upLeft,lowRight] = regionInfo(gridID,regionID,fieldname)</code> returns the dimensions and corner points for the specified field of a subsetted region identified by <code>regionID</code> in the grid identified by <code>gridID</code>.</p> <p>This function corresponds to the <code>GDregioninfo</code> function in the HDF-EOS library C API.</p> |
| Examples | <pre>import matlab.io.hdfeos.* gfid = gd.open('grid.hdf','read'); gridID = gd.attach(gfid,'PolarGrid'); cornerlat = [20 50]; cornerlon = [-90 -60]; regionID = gd.defBoxRegion(gridID,cornerlat,cornerlon); [dims,upleft,lowright] = gd.regionInfo(gridID,regionID,'ice_temp'); data = gd.extractRegion(gridID,regionID,'ice_temp'); gd.detach(gridID); gd.close(gfid);</pre> |
| See Also | <code>gd.defBoxRegion</code> <code>gd.defVrtRegion</code> |

matlab.io.hdfEOS.gd.setFillValue

Purpose Set fill value for specified field

Syntax `setFillValue(gridID,fieldname,fillvalue)`

Description `setFillValue(gridID,fieldname,fillvalue)` sets the fill value for the specified field. The fill value should have the same data type as the field.

This function corresponds to the `GDsetfillvalue` function in the HDF-EOS library C API.

Examples Create a new double-precision field with a fill value of -1.

```
import matlab.io.hdfEOS.*
srcFile = fullfile(matlabroot,'toolbox','matlab','imagesci','grid.hdf');
copyfile(srcFile,'myfile.hdf');
fileattrib('myfile.hdf','+w');
gfid = gd.open('myfile.hdf','rdwr');
gridID = gd.attach(gfid,'PolarGrid');
gd.defComp(gridID,'none');
gd.defField(gridID,'newfield',{'XDim','YDim'},'double');
gd.setFillValue(gridID,'newfield',-1);
gd.detach(gridID);
gd.close(gfid);
```

See Also `gd.getFillValue`

Purpose

Set tiling and compression for field with fill value

Syntax

```
setTileComp(gridID,fieldname,tilesize,compCode,compParm)
```

Description

`setTileComp(gridID,fieldname,tilesize,compCode,compParm)` sets the tiling and compression for a field that had a fill value. This function must be applied after `gd.defField` and `gd.setFillValue`. The `compCode` argument can be one of the following strings.

| | |
|-----------|---------------------|
| 'rle' | Run-length encoding |
| 'skphuff' | Skipping Huffman |
| 'deflate' | Deflate |
| 'none' | No compression |

`compParm` need only be specified when the compression scheme is 'deflate', and then must be an integer between 0 and 9.

This function corresponds to the `GDsettilecomp` function in the HDF-EOS library C API, but because MATLAB uses FORTRAN-style ordering, the `tilesize` parameter is reversed with respect to the C library API.

Examples

Define a temperature field with a 2-by-2 tiling scheme, a fill value of -999, and deflate compression.

```
import matlab.io.hdfeos.*
gfid = gd.open('myfile.hdf','create');
upleft = [210584.50041 3322395.95445];
lowright = [813931.10959 2214162.53278];
gridID = gd.create(gfid,'UTMGrid',120,200,upleft,lowright);
spherecode = 0; zonecode = 40;
projparm = zeros(1,13);
gd.defProj(gridID,'utm',zonecode,spherecode,projparm);
gd.defDim(gridID,'Time',10);
gd.defField(gridID,'Pollution',{ 'XDim','YDim','Time'},'float');
gd.setFillValue(gridID,'Pollution',single(7));
```

matlab.io.hdfEOS.gd.setTileComp

```
gd.setTileComp(gridID, 'Pollution', [40 20 1], 'deflate', 5);  
gd.detach(gridID);  
gd.close(gfid);
```

See Also

[gd.defTile](#) | [gd.defComp](#)

Purpose Name corresponding to GCTP sphere code

Syntax `name = sphereCodeToName(code)`

Description `name = sphereCodeToName(code)` returns the name for the spheroid corresponding to the spheroid code. The list of supported GCTP spheroids is as follows:

| GCTP Spheroid Code | Spheroid Name |
|--------------------|---------------------|
| 0 | Clarke 1866 |
| 1 | Clarke 1880 |
| 2 | Bessel |
| 3 | International 1967 |
| 4 | International 1909 |
| 5 | WGS 72 |
| 6 | Everest |
| 7 | WGS 66 |
| 8 | GRS 1980 |
| 9 | Airy |
| 10 | Modified Airy |
| 11 | Modified Everest |
| 12 | WGS 84 |
| 13 | Southeast Asia |
| 14 | Australian National |
| 15 | Krassovsky |
| 16 | Hough |
| 17 | Mercury 1960 |

matlab.io.hdfEOS.gd.sphereCodeToName

| GCTP Spheroid Code | Spheroid Name |
|--------------------|-------------------------------|
| 18 | Modified Mercury 1968 |
| 19 | Sphere of radius 6370997m |
| 20 | Sphere of radius 6371228m |
| 21 | Sphere of radius 6371007.181m |

See Also

`gd.defProj` | `gd.sphereNameToCode`

Purpose Numeric GCTP code corresponding to sphere name

Syntax `code = sphereCodeToName(name)`

Description `code = sphereCodeToName(name)` returns the numeric GCTP code corresponding to the named spheroid. The list of supported GCTP spheroids is as follows:

| GCTP Spheroid Code | Spheroid Name |
|--------------------|---------------------|
| 0 | Clarke 1866 |
| 1 | Clarke 1880 |
| 2 | Bessel |
| 3 | International 1967 |
| 4 | International 1909 |
| 5 | WGS 72 |
| 6 | Everest |
| 7 | WGS 66 |
| 8 | GRS 1980 |
| 9 | Airy |
| 10 | Modified Airy |
| 11 | Modified Everest |
| 12 | WGS 84 |
| 13 | Southeast Asia |
| 14 | Australian National |
| 15 | Krassovsky |
| 16 | Hough |
| 17 | Mercury 1960 |

matlab.io.hdfEOS.gd.sphereNameToCode

| GCTP Spheroid Code | Spheroid Name |
|--------------------|-------------------------------|
| 18 | Modified Mercury 1968 |
| 19 | Sphere of radius 6370997m |
| 20 | Sphere of radius 6371228m |
| 21 | Sphere of radius 6371007.181m |

See Also

`gd.defProj` | `gd.sphereCodeToName`

| | |
|--------------------|--|
| Purpose | Tile size of grid field |
| Syntax | <code>tileDims = tileInfo(gridID,fieldname)</code> |
| Description | <p><code>tileDims = tileInfo(gridID,fieldname)</code> returns the tile dimensions of the field specified by <code>fieldname</code> in the grid specified by <code>gridID</code>. If the field is not tiled, then <code>tileDims</code> is <code>[]</code>.</p> <p>This function corresponds to the <code>GDtileinfo</code> function in the HDF-EOS library C API, but because MATLAB uses FORTRAN-style ordering, the <code>tileDims</code> parameter is reversed with respect to the C library API.</p> |
| Examples | <pre>import matlab.io.hdfeos.* gfid = gd.open('grid.hdf'); gridID = gd.attach(gfid,'PolarGrid'); tileDims = gd.tileInfo(gridID,'pressure'); gd.detach(gridID); gd.close(gfid);</pre> |
| See Also | <code>gd.defTile</code> |

matlab.io.hdfEOS.gd.writeAttr

Purpose Write grid attribute

Syntax writeAttr(gridID,attrname,data)

Description writeAttr(gridID,attrname,data) writes an attribute to a grid. If the attribute does not exist, it is created. If the attribute exists, it can be modified in place, but it cannot be recreated with a different data type or length.

This function corresponds to the GDwriteattr function in the HDF-EOS library C API.

Examples

```
import matlab.io.hdfEOS.*
srcFile = fullfile(matlabroot,'toolbox','matlab','imagesci','grid.hdf');
copyfile(srcFile,'myfile.hdf');
fileattrib('myfile.hdf','+w');
gfid = gd.open('myfile.hdf','rdwr');
gridID = gd.attach(gfid,'PolarGrid');
gd.writeAttr(gridID,'modification_date',datestr(now));
gd.detach(gridID);
gd.close(gfid);
```

See Also gd.readAttr

Purpose

Write Block SOM offset

Syntax

```
writeBlkSomOffset(gridID,offset)
```

Description

`writeBlkSomOffset(gridID,offset)` writes the block SOM offset values `n` pixels for a standard Solar Oblique Mercator (SOM) projection. `offset` is a vector of offset values for SOM projection data. This routine can only be used with grids that use the SOM projection. You must take care to use this function properly in conjunction with `gd.defProj`. The 12th element of the projection parameters must be set to the total number of blocks to be defined. `offset` starts by listing the offset to the second block, so the 12th element of the projection parameters is always one more than the length of `offset`.

All fields defined after writing the block SOM offset values will automatically include "SOMBlockDim" as the slowest varying dimension.

This function corresponds to the `GDbkSOMoffset` function in the HDF-EOS library C API.

Examples

```
import matlab.io.hdfeos.*
gfid = gd.open('myfile.hdf','create');
lowright = [30521379.68485 1152027.64253];
upleft = [-11119487.42844 8673539.24806];
gridID = gd.create(gfid,'SOM',120,60,upleft,lowright);
projparm(1) = 6378137;
projparm(2) = 0.006694348;
projparm(4) = 98096360; % 98.161 in DDDMMMSSS
projparm(5) = 87069061; % 87.112 in DDDMMMSSS
projparm(9) = 0.068585416*1440;
projparm(10) = 0.0;
projparm(12) = 6;
gd.defProj(gridID,'som',[],[],projparm);
gd.writeBlkSomOffset(gridID,[5 10 12 8 2]);
gd.detach(gridID);
gd.close(gfid);
```

matlab.io.hdfEOS.gd.writeBlkSomOffset

See Also

`gd.readBlkSomOffset`

Purpose

Write data to grid field

Syntax

```
writeField(gridID,fieldname,data)
writeField(gridID,fieldname,start,data)
writeField(gridID,fieldname,start,stride,data)
```

Description

`writeField(gridID,fieldname,data)` writes all the data to a grid field. The field is identified by `fieldname` and the grid is identified by `gridID`.

`writeField(gridID,fieldname,start,data)` writes a contiguous hyperslab to the grid field. `start` specifies the zero-based starting index.

`writeField(gridID,fieldname,start,stride,data)` writes a strided hyperslab of data to a grid data field. `stride` specifies the inter-element spacing along each dimension. The number of elements to write along each dimension is inferred from the size of `data`.

This function corresponds to the `GDwritefield` function in the HDF-EOS library C API, but because MATLAB uses FORTRAN-style ordering, the `start` and `stride` parameters are reversed with respect to the C library API.

Examples

Write all the data to a grid field.

```
import matlab.io.hdfEOS.*
srcFile = fullfile(matlabroot,'toolbox','matlab','imagesci','grid.hdf');
copyfile(srcFile,'myfile.hdf');
fileattrib('myfile.hdf','+w');
gfid = gd.open('myfile.hdf','rdwr');
gridID = gd.attach(gfid,'PolarGrid');
data = zeros(100,100,'uint16');
gd.writeField(gridID,'ice_temp',data);
gd.detach(gridID);
gd.close(gfid);
```

See Also

`gd.readField`

matlab.io.hdfeos.gd.writeTile

Purpose Write tile to field

Syntax writeTile(gridID,fieldname,tileCoords,data)

Description writeTile(gridID,fieldname,tileCoords,data) writes a single tile of data to a field. If the field data can be arranged tile by tile, this routine is more efficient than gd.writeField. In all other cases, use gd.writeField. The tileCoords argument has the form [rownum colnum] and is defined in terms of the tile coordinates, not the data elements.

This function corresponds to the GDwritetile function in the HDF-EOS library C API, but because MATLAB uses FORTRAN-style ordering, the tileCoords parameter is reversed with respect to the C library API.

Examples Define a field with a 2-by-3 tiling scheme.

```
import matlab.io.hdfeos.*
gfid = gd.open('myfile.hdf','create');
xdim = 200; ydim = 180;
gridID = gd.create(gfid,'PolarGrid',xdim,ydim,[],[]);
zonecode = 40;
spherecode = 0;
projParm = zeros(1,13);
projParm(6) = 90000000;
gd.defProj(gridID,'ps',[],spherecode,projParm);
tileSize = [100 60];
gd.defTile(gridID,tileSize);
dimlist = {'XDim','YDim'};
gd.defField(gridID,'Pressure',dimlist,'int32');
for c = 0:2
    for r = 0:1
        data = (r+c)*ones(tileSize,'int32');
        gd.writeTile(gridID,'Pressure',[r c],data);
    end
end
gd.detach(gridID);
```

```
gd.close(gfid);
```

See Also

```
gd.readTile
```

Purpose Low-level access to HDF-EOS swath files

Description To use these MATLAB functions, you must be familiar with the HDF-EOS library C interface. In most cases, the syntax of the MATLAB function is similar to the syntax of the corresponding HDF-EOS library function. The functions are implemented as the package `matlab.io.hdfeos.sw`. To use this package, prefix the function name with a package path, or use the `import` function to add the package to the current import list, prior to calling the function, for example,

```
import matlab.io.hdfeos.*  
fileId = sw.open(filename);
```

Access

| | |
|---|----------------------------|
| <code>matlab.io.hdfeos.sw.attach</code> | Attach to swath data set |
| <code>matlab.io.hdfeos.sw.close</code> | Close swath file |
| <code>matlab.io.hdfeos.sw.create</code> | Create new swath structure |
| <code>matlab.io.hdfeos.sw.detach</code> | Detach from swath |
| <code>matlab.io.hdfeos.sw.open</code> | Open swath file |

Definition

| | |
|---|------------------------------------|
| <code>matlab.io.hdfeos.sw.defComp</code> | Set grid field compression |
| <code>matlab.io.hdfeos.sw.defDataField</code> | Define new data field within swath |
| <code>matlab.io.hdfeos.sw.defDim</code> | Define new dimension within swath |

| | |
|---------------------------------|--|
| matlab.io.hdfEOS.sw.defDimMap | Define mapping between geolocation and data dimensions |
| matlab.io.hdfEOS.sw.defGeoField | Define new data field within swath |

Basic I/O

| | |
|----------------------------------|--|
| matlab.io.hdfEOS.sw.getFillValue | Fill value for specified field |
| matlab.io.hdfEOS.sw.readAttr | Read swath attribute |
| matlab.io.hdfEOS.sw.readField | Read data from swath field |
| matlab.io.hdfEOS.sw.setFillValue | Set fill value for the specified field |
| matlab.io.hdfEOS.sw.writeAttr | Write swath attribute |
| matlab.io.hdfEOS.sw.writeField | Write data to swath field |

Inquiry

| | |
|-----------------------------------|---|
| matlab.io.hdfEOS.sw.compInfo | Compression information for field |
| matlab.io.hdfEOS.sw.dimInfo | Size of dimension |
| matlab.io.hdfEOS.sw.fieldInfo | Information about swath field |
| matlab.io.hdfEOS.sw.geoMapInfo | Type of dimension mapping for named dimension |
| matlab.io.hdfEOS.sw.idxMapInfo | Indexed array of geolocation mapping |
| matlab.io.hdfEOS.sw.inqAttrs | Names of swath attributes |
| matlab.io.hdfEOS.sw.inqDataFields | Information about geolocation fields |
| matlab.io.hdfEOS.sw.inqDims | Information about dimensions defined in swath |

| | |
|----------------------------------|--|
| matlab.io.hdfEOS.sw.inqGeoFields | Information about geolocation fields |
| matlab.io.hdfEOS.sw.inqIdxMaps | Information about swath indexed geolocation mapping |
| matlab.io.hdfEOS.sw.inqMaps | Information about swath geolocation relations |
| matlab.io.hdfEOS.sw.inqSwath | Names of swaths in file |
| matlab.io.hdfEOS.sw.mapInfo | Offset and increment of specific geolocation mapping |
| matlab.io.hdfEOS.sw.nEntries | Number of entries for specific type |

Subsetting

| | |
|-----------------------------------|--|
| matlab.io.hdfEOS.sw.defBoxRegion | Define latitude-longitude region for swath |
| matlab.io.hdfEOS.sw.defTimePeriod | Define time period of interest |
| matlab.io.hdfEOS.sw.defVrtRegion | Subset on monotonic field or dimension |
| matlab.io.hdfEOS.sw.extractPeriod | Read data from subsetted time period |
| matlab.io.hdfEOS.sw.extractRegion | Read subsetted region |
| matlab.io.hdfEOS.sw.periodInfo | Information about subsetted period |
| matlab.io.hdfEOS.sw.regionInfo | Information about subsetted region |

Purpose Attach to swath data set

Syntax `swathID = attach(swfid,swathname)`

Description `swathID = attach(swfid,swathname)` attaches to the swath identified by `swathname` in the file identified by `swfid`. The `swathID` output is the identifier for the named swath.

This function corresponds to the `SWattach` function in the HDF-EOS library C API.

Examples

```
import matlab.io.hdfEOS.*
swfid = sw.open('swath.hdf');
swathID = sw.attach(swfid,'Example Swath');
sw.detach(swathID);
sw.close(swfid);
```

See Also `sw.detach`

matlab.io.hdfEOS.sw.close

Purpose Close swath file

Syntax `close(swfid)`

Description `close(swfid)` closes an HDF-EOS swath file identified by `swfid`. This function corresponds to the `SWclose` function in the HDF-EOS library C API.

Examples

```
import matlab.io.hdfEOS.*
swfid = sw.open('myfile.hdf','create');
swathID = sw.create(swfid,'ExampleSwath');
sw.detach(swathID);
sw.close(swfid);
```

See Also `sw.open` | `sw.create`

Purpose

Compression information for field

Syntax

```
[code,parms] = compInfo(swathID,fieldname)
```

Description

[code,parms] = compInfo(swathID,fieldname) returns the compression code and compression parameters for a given field. Refer to `sw.defComp` for a description of various compression schemes and parameters.

This function corresponds to the `SWcompinfo` function in the HDF-EOS library C API.

Examples

```
import matlab.io.hdfEOS.*  
swfid = sw.open('swath.hdf');  
swathID = sw.attach(swfid,'Example Swath');  
[compCode,parms] = sw.compInfo(swathID,'Spectra');  
sw.detach(swathID);  
sw.close(swfid);
```

See Also

`sw.defComp`

matlab.io.hdfEOS.sw.create

Purpose Create new swath structure

Syntax `swathID = create(swfID,swathname)`

Description `swathID = create(swfID,swathname)` creates a new swath structure where `swfID` is the swath file identifier and `swathname` is the name of the new swath. The swath is created as a Vgroup with the HDF file with the name `swathname` and HDF Vgroup class 'SWATH'.

This function corresponds to the `SWcreate` function in the HDF-EOS library C API.

Examples

```
import matlab.io.hdfEOS.*
swfid = sw.open('myfile.hdf','create');
swathID = sw.create(swfid,'ExampleSwath');
sw.detach(swathID);
sw.close(swfid);
```

See Also `sw.detach`

Purpose

Define latitude-longitude region for swath

Syntax

```
regionID = defBoxRegion(swathID,lat,lon,mode)
```

Description

`regionID = defBoxRegion(swathID,lat,lon,mode)` defines a latitude-longitude box region for a swath. `lat` and `lon` are two-element arrays containing the latitude and longitude in decimal degrees of the box corners. A cross track is determined to be within the box if a condition is met according to the value of `mode`:

| | |
|-------------|---|
| 'MIDPOINT' | The cross track midpoint is within the box. |
| 'ENDPOINT' | Either endpoint is within the box. |
| 'ANYPPOINT' | Any point of the cross track is within the box. |

All elements of a cross track are within the region if the condition is met. The swath must have both Longitude and Latitude (or Colatitude) defined.

`regionID` is an identifier to be used by `sw.extractRegion` to read all the entries of a data field within the region.

This function corresponds to the `SWdefboxregion` and `SWregionindex` functions in the HDF-EOS library C API.

Examples

```
import matlab.io.hdfEOS.*
swfid = sw.open('swath.hdf');
swathID = sw.attach(swfid,'Example Swath');
lat = [34 44];
lon = [16 24];
regionID = sw.defBoxRegion(swathID,lat,lon,'MIDPOINT');
data = sw.extractRegion(swathID,regionID,'Temperature');
sw.detach(swathID);
sw.close(swfid);
```

matlab.io.hdfEOS.sw.defBoxRegion

See Also

`sw.extractRegion`

Purpose

Set grid field compression

Syntax

```
defComp(swathID,compscheme,compparm)
```

Description

`defComp(swathID,compscheme,compparm)` sets the field compression for subsequent definitions. The compression scheme does not apply to one-dimensional fields. `compscheme` can be one of the following strings.

| | |
|-----------|---------------------|
| 'rle' | Run-length encoding |
| 'skphuff' | Skipping Huffman |
| 'deflate' | Gzip compression |
| 'none' | No compression |

When the compression scheme is 'deflate', the `compparm` input is the deflate compression level, an integer between 0 and 9. `compparm` can be omitted for the other compression schemes.

Fields defined with compression must be written with a single call to `sw.writeField`.

This function corresponds to the `SWdefcomp` function in the HDF-EOS library C API.

Examples

```
import matlab.io.hdfEOS.*
swfid = sw.open('myfile.hdf','create');
swathID = sw.create(swfid,'MySwath');
sw.defDim(swathID,'Track',4000);
sw.defDim(swathID,'Xtrack',2000);
sw.defDim(swathID,'Bands',3);
sw.defComp(swathID,'rle');
dims = {'Xtrack','Track'};
sw.defDataField(swathID,'Pressure',dims,'float');
sw.defComp(swathID,'deflate',5);
sw.defDataField(swathID,'Opacity',dims,'float');
sw.defComp(swathID,'skphuff');
dims = {'Xtrack','Track','Bands'};
```

```
sw.defDataField(swathID, 'Spectra', dims, 'float');  
sw.defComp(swathID, 'none');  
dims = {'Xtrack', 'Track'};  
sw.defDataField(swathID, 'Temperature', dims, 'float');  
sw.detach(swathID);  
sw.close(swfid);
```

See Also

`sw.compInfo`

Purpose

Define new data field within swath

Syntax

```
defDataField(swathID,fieldname,dimlist,dtype)
defDataField(swathID,fieldname,dimlist,dtype,mergeCode)
```

Description

`defDataField(swathID,fieldname,dimlist,dtype)` defines a data field to be stored in the swath identified by `swathID`. The `dimlist` input can be a cell array of dimension names, or a single char if there is only one dimension. `dtype` is the data type of the field and can be one of the following strings.

- 'double'
- 'single'
- 'int32'
- 'uint32'
- 'int16'
- 'uint16'
- 'int8'
- 'uint8'
- 'char'

`dimlist` should be ordered such that the fastest varying dimension is listed first. This is opposite from the order in which the dimensions are listed in the C API.

`defDataField(swathID,fieldname,dimlist,dtype,mergeCode)` defines a data field that can be merged with other data fields according to the value of `mergeCode`. The `mergeCode` input can be one of two strings, 'automerge' and 'nomerge'. If `mergeCode` is 'automerge', then the HDF-EOS library will attempt to merge swath fields into a single object. This should not be done if you wish to access the swath fields individually with the another interface. By default, `mergeCode` is 'nomerge'.

Note To assure that the fields defined by `sw.defDataField` are properly established in the file, the swath should be detached and then reattached before writing to any fields.

This function corresponds to the `SWdefdatafield` function in the HDF-EOS library C API, but because MATLAB uses FORTRAN-style ordering, the `dimlist` parameter is reversed with respect to the C library API.

Examples

```
import matlab.io.hdfEOS.*
swfid = sw.open('myfile.hdf','create');
swathID = sw.create(swfid,'MySwath');
sw.defDim(swathID,'GeoTrack',2000);
sw.defDim(swathID,'GeoXtrack',1000);
sw.defDim(swathID,'DataTrack',4000);
sw.defDim(swathID,'DataXtrack',2000);
sw.defDim(swathID,'Bands',3);
sw.defDimMap(swathID,'GeoTrack','DataTrack',0,2);
sw.defDimMap(swathID,'GeoXtrack','DataXtrack',1,2);
dims = {'GeoXtrack','GeoTrack'};
sw.defGeoField(swathID,'Longitude',dims,'float');
sw.defGeoField(swathID,'Latitude',dims,'float');
dims = {'DataXtrack','DataTrack','Bands'};
sw.defDataField(swathID,'Spectra',dims,'float');
sw.detach(swathID);
sw.close(swfid);
```

See Also

`sw.defGeoField` | `sw.inqDataFields`

Purpose Define new dimension within swath

Syntax `defDim(swathID,dimname,dimlen)`

Description `defDim(swathID,dimname,dimlen)` defines a new dimension named `dimname` with length `dimlen` in the swath structure identified by `swathID`.

To specify an unlimited dimension, use either 0 or 'unlimited' for `dimlen`.

This function corresponds to the `SWdefdim` function in the HDF-EOS library.

Examples Define a dimension 'Band' with length of 15 and an unlimited dimension 'Time'.

```
import matlab.io.hdfEOS.*
swfid = sw.open('myfile.hdf','create');
swathID = sw.create(swfid,'MySwath');
sw.defDim(swathID,'GeoTrack',2000);
sw.defDim(swathID,'GeoXtrack',1000);
sw.defDim(swathID,'DataTrack',4000);
sw.defDim(swathID,'DataXtrack',2000);
sw.detach(swathID);
sw.close(swfid);
```

See Also `sw.dimInfo`

matlab.io.hdfEOS.sw.defDimMap

Purpose Define mapping between geolocation and data dimensions

Syntax `defDimMap(swathID,geoDim,dataDim,offset,increment)`

Description `defDimMap(swathID,geoDim,dataDim,offset,increment)` defines a monotonic mapping between the geolocation and data dimensions, which usually have differing lengths. `offset` gives the index of the data element corresponding to the first geolocation element, and `increment` gives the number of data elements to skip for each geolocation element. If the geolocation dimension begins "before" the data dimension, then `offset` is negative. Similarly, if the geolocation dimension has higher resolution than the data dimension, then `increment` is negative.

This function corresponds to the `SWdefdimmap` function in the HDF-EOS library.

Examples Create a dimension mapping such that the first element of the GeoTrack dimension corresponds to the first element of the DataTrack Dimension and such that the data dimension has twice the resolution as the geolocation dimension. Also create a dimension mapping such that the first element of the GeoXtrack dimension corresponds to the second element of the DataXtrack dimensions and such that the data dimension has twice the resolution as the geolocation dimension.

```
import matlab.io.hdfEOS.*
swfid = sw.open('myfile.hdf','create');
swathID = sw.create(swfid,'MySwath');
sw.defDim(swathID,'GeoTrack',2000);
sw.defDim(swathID,'GeoXtrack',1000);
sw.defDim(swathID,'DataTrack',4000);
sw.defDim(swathID,'DataXtrack',2000);
sw.defDimMap(swathID,'GeoTrack','DataTrack',0,2);
sw.defDimMap(swathID,'GeoXtrack','DataXtrack',1,2);
sw.detach(swathID);
sw.close(swfid);
```

See Also `sw.defDim` | `sw.mapInfo`

Purpose

Define new data field within swath

Syntax

```
defGeoField(swathID,fieldname,dimlist,dtype)
defGeoField(swathID,fieldname,dimlist,dtype,mergeCode)
```

Description

`defGeoField(swathID,fieldname,dimlist,dtype)` defines a geolocation field to be stored in the swath identified by `swathID`. The `dimlist` argument can be a cell array of dimension names or a single char if there is only one dimension. `dtype` is the data type of the field. `dimlist` should be ordered such that the fastest varying dimension is listed first. This is opposite from the order in which the dimensions are listed in the C API.

`defGeoField(swathID,fieldname,dimlist,dtype,mergeCode)` defines a geolocation field that may be merged with other geolocation fields according to the value of `mergeCode`. The `mergeCode` argument can be one of two strings, 'automerge' and 'nomerge'. If `mergeCode` is 'automerge', then the HDF-EOS library will attempt to merge swath fields into a single object. This should not be done if you wish to access the swath fields individually with the another interface. By default, `mergeCode` is 'nomerge'.

This function corresponds to the `SWdefgeofield` function in the HDF-EOS library C API, but because MATLAB uses FORTRAN-style ordering, the `dimlist` parameter is reversed with respect to the C library API.

Examples

```
import matlab.io.hdfeos.*
swfid = sw.open('myfile.hdf','create');
swathID = sw.create(swfid,'MySwath');
sw.defDim(swathID,'GeoTrack',2000);
sw.defDim(swathID,'GeoXtrack',1000);
sw.defDim(swathID,'DataTrack',4000);
sw.defDim(swathID,'DataXtrack',2000);
sw.defDimMap(swathID,'GeoTrack','DataTrack',0,2);
sw.defDimMap(swathID,'GeoXtrack','DataXtrack',1,2);
dims = {'GeoXtrack','GeoTrack'};
```

matlab.io.hdfEOS.sw.defGeoField

```
sw.defGeoField(swathID, 'Longitude', dims, 'float');  
sw.defGeoField(swathID, 'Latitude', dims, 'float');  
sw.detach(swathID);  
sw.close(swfid);
```

See Also

[sw.defDataField](#) | [sw.inqGeoFields](#)

Purpose Define time period of interest

Syntax `outpID = defTimePeriod(swathID,start,stop,mode)`

Description `outpID = defTimePeriod(swathID,start,stop,mode)` defines a time period for a swath. `outpID` is a swath period ID that can be used to read all the entries of a data field within the time period. The swath structure must have the 'Time' field defined. A cross track is within a time period if a condition is met according to the value of mode:

| | |
|------------|--|
| 'MIDPOINT' | The midpoint is within the time period. |
| 'ENDPOINT' | Either endpoint is within the time period. |

This function corresponds to the `SWdeftimeperiod` function in the HDF-EOS library C API.

Examples

```
import matlab.io.hdfEOS.*
swfid = sw.open('swath.hdf');
swathID = sw.attach(swfid,'Example Swath');
starttime = 25;
stoptime = 425;
periodID = sw.defTimePeriod(swathID,starttime,stoptime,'MIDPOINT');
data = sw.extractPeriod(swathID,periodID,'Temperature');
sw.detach(swathID);
sw.close(swfid);
```

See Also `sw.defBoxRegion` | `sw.defVrtRegion` | `sw.extractPeriod`

matlab.io.hdfeos.sw.defVrtRegion

Purpose Subset on monotonic field or dimension

Syntax `regionID_out = defVrtRegion(swathID,regionID,vertObj,range)`

Description `regionID_out = defVrtRegion(swathID,regionID,vertObj,range)` subsets on a monotonic field or contiguous elements of a dimension. Whereas `defBoxRegion` and `defTimePeriod` subset along the 'Track' dimension, this routine allows the user to subset along any dimension. `regionID` specifies the subsetted region from a previous call. `vertObj` specifies the dimension by which to subset. `range` specifies the minimum and maximum values for `vertObj`.

If there is no current subsetted region, `regionID` should be 'noprevsub'.

`vertObj` can be either a dimension or a field. If it is a dimension, then `range` should consist of dimension indices. If `vertObj` corresponds to a field, then `range` should consist of the minimum and maximum field values. `vertObj` must be one-dimensional in this case, and the its values must be monotonic.

This function corresponds to the `SWdefvrtregion` function in the HDF-EOS library C API.

Examples

```
import matlab.io.hdfeos.*
swfid = sw.open('swath.hdf');
swathID = sw.attach(swfid,'Example Swath');
regionID = sw.defVrtRegion(swathID,'noprevsub','Bands',[450 600]);
data = sw.extractRegion(swathID,regionID,'Spectra');
sw.detach(swathID);
sw.close(swfid);
```

See Also `sw.defBoxRegion` | `sw.defTimePeriod`

Purpose Detach from swath

Syntax `detach(swathID)`

Description `detach(swathID)` detaches from the swath identified by `swathID`. This function corresponds to the `SWdetach` function in the HDF-EOS library C API.

Examples

```
import matlab.io.hdfEOS.*
swfid = sw.open('swath.hdf');
swathID = sw.attach(swfid, 'Example Swath');
sw.detach(swathID);
sw.close(swfid);
```

See Also `sw.attach` | `sw.create`

matlab.io.hdfEOS.sw.dimInfo

Purpose Size of dimension

Syntax `dimlen = dimInfo(swathID,dimname)`

Description `dimlen = dimInfo(swathID,dimname)` returns the length of the specified dimension.

This function corresponds to the `SWdiminfo` function in the HDF-EOS library C API.

Examples

```
import matlab.io.hdfEOS.*
swfid = sw.open('swath.hdf');
swathID = sw.attach(swfid,'Example Swath');
dimlen = sw.dimInfo(swathID,'GeoTrack');
sw.detach(swathID);
sw.close(swfid);
```

See Also `sw.defDim`

Purpose Read data from subsetted time period

Syntax `data = extractPeriod(swathID,periodID,fieldname)`

Description `data = extractPeriod(swathID,periodID,fieldname)` reads data for the given field for the time period specified by `periodID`.

This routine corresponds to the `SWextractperiod` function in the HDF-EOS library C API.

Examples

```
import matlab.io.hdfeos.*
swfid = sw.open('swath.hdf');
swathID = sw.attach(swfid,'Example Swath');
starttime = 25;
stoptime = 425;
periodID = sw.defTimePeriod(swathID,starttime,stoptime,'MIDPOINT');
data = sw.extractPeriod(swathID,periodID,'Temperature');
sw.detach(swathID);
sw.close(swfid);
```

See Also `sw.defTimePeriod`

matlab.io.hdfEOS.sw.extractRegion

Purpose Read subsetted region

Syntax `data = extractRegion(swathID,regionID,fieldname)`

Description `data = extractRegion(swathID,regionID,fieldname)` reads data for a specified field from a subsetted region identified by `regionID`.

This function corresponds to the `SWextractregion` function in the HDF-EOS library C API.

Examples

```
import matlab.io.hdfEOS.*
swfid = sw.open('swath.hdf');
swathID = sw.attach(swfid,'Example Swath');
lat = [34 44];
lon = [16 24];
regionID = sw.defBoxRegion(swathID,lat,lon,'MIDPOINT');
data = sw.extractRegion(swathID,regionID,'Temperature');
sw.detach(swathID);
sw.close(swfid);
```

See Also `sw.defBoxRegion` | `sw.defVrtRegion`

| | |
|--------------------|---|
| Purpose | Information about swath field |
| Syntax | <code>[dimsizes, ntype, dimlist] = fieldInfo(swathID, fieldname)</code> |
| Description | <p><code>[dimsizes, ntype, dimlist] = fieldInfo(swathID, fieldname)</code> returns the size, data type, and list of named dimensions for the specified swath geolocation or data field.</p> <p>This function corresponds to the <code>SWfieldinfo</code> function in the HDF-EOS library C API, but because MATLAB uses FORTRAN-style ordering, the <code>dimlist</code> parameter is reversed with respect to the C library API.</p> |
| Examples | <pre>import matlab.io.hdfEOS.* swfid = sw.open('swath.hdf'); swathID = sw.attach(swfid, 'Example Swath'); [fieldSize, ntype, dimlist] = sw.fieldInfo(swathID, 'Spectra'); sw.detach(swathID); sw.close(swfid);</pre> |
| See Also | <code>sw.inqGeoFields</code> <code>sw.inqDataFields</code> |

matlab.io.hdfEOS.sw.geoMapInfo

Purpose Type of dimension mapping for named dimension

Syntax `mappingType = geoMapInfo(swathID,dimname)`

Description `mappingType = geoMapInfo(swathID,dimname)` returns the type of dimension mapping for the named dimension. `mappingType` is one of 'indexed', 'regular', or 'unmapped'.

This routine corresponds to the `SWgeomapinfo` function in the HDF-EOS library C API.

Examples

```
import matlab.io.hdfEOS.*
swfid = sw.open('swath.hdf');
swathID = sw.attach(swfid,'Example Swath');
maptype = sw.geoMapInfo(swathID,'GeoTrack');
sw.detach(swathID);
sw.close(swfid);
```

See Also `sw.defDimMap`

Purpose Fill value for specified field

Syntax `fillvalue = getFillValue(swathID,fieldname)`

Description `fillvalue = getFillValue(swathID,fieldname)` returns the fill value for the specified field.

This function corresponds to the `SWgetfillvalue` function in the HDF-EOS library C API.

Examples

```
import matlab.io.hdfEOS.*
swfid = sw.open('swath.hdf');
swathID = sw.attach(swfid,'Example Swath');
fv = sw.getFillValue(swathID,'Spectra');
sw.detach(swathID);
sw.close(swfid);
```

See Also `sw.setFillValue`

matlab.io.hdfEOS.sw.idxMapInfo

Purpose Indexed array of geolocation mapping

Syntax `idx = idxMapInfo(swathID,geodim,datadim)`

Description `idx = idxMapInfo(swathID,geodim,datadim)` retrieves the indexed elements of the geolocation mapping between `geodim` and `datadim`.

This function corresponds to the `SWidxmapinfo` function in the HDF-EOS C library API.

See Also `sw.geoMapInfo`

Purpose Names of swath attributes

Syntax `attrlist = inqAttrs(swathID)`

Description `attrlist = inqAttrs(swathID)` returns the list of swath attribute names. `attrlist` is a cell array.

This function corresponds to the `SWinqattrs` function in the HDF-EOS library C API.

Examples

```
import matlab.io.hdfEOS.*
swfid = sw.open('swath.hdf');
swathID = sw.attach(swfid, 'Example Swath');
attrList = sw.inqAttrs(swathID);
sw.detach(swathID);
sw.close(swfid);
```

See Also `sw.readAttr` | `sw.writeAttr`

matlab.io.hdfeos.sw.inqDataFields

Purpose Information about geolocation fields

Syntax [fields,rank,datatype] = inqDataFields(swathID)

Description [fields,rank,datatype] = inqDataFields(swathID) returns the list of geolocation field names, the rank of each field, and the data type of each field.

This function corresponds to the SWinqdatafields function in the HDF-EOS library C API, but because MATLAB uses FORTRAN-style ordering, the fields parameter is reversed with respect to the C library API.

Examples

```
import matlab.io.hdfeos.*
swfid = sw.open('swath.hdf');
swathID = sw.attach(swfid,'Example Swath');
[fields,rank,datatype] = sw.inqDataFields(swathID);
sw.detach(swathID);
sw.close(swfid);
```

See Also sw.defDataField | sw.inqGeoFields

Purpose Information about dimensions defined in swath

Syntax [dimnames,dimlens] = inqDims(swathID)

Description [dimnames,dimlens] = inqDims(swathID) returns the names of the dimensions dimnames as a cell array. The length of each respective dimension is returned in dimlens.

This function corresponds to the SWinqdims routine in the HDF-EOS library.

Examples

```
import matlab.io.hdfEOS.*
swfid = sw.open('swath.hdf');
swathID = sw.attach(swfid,'Example Swath');
[dimnames,dimlens] = sw.inqDims(swathID);
sw.detach(swathID);
sw.close(swfid);
```

See Also sw.defDim

matlab.io.hdfeos.sw.inqGeoFields

Purpose Information about geolocation fields

Syntax `[fields,rank,datatype] = inqGeoFields(swathID)`

Description `[fields,rank,datatype] = inqGeoFields(swathID)` returns the list of geolocation fields `fields`, the rank of each field, and the data type of each field.

This function corresponds to the `SWinqgeofields` function in the HDF-EOS library C API, but because MATLAB uses FORTRAN-style ordering, the `fields` parameter is reversed with respect to the C library API.

Examples

```
import matlab.io.hdfeos.*
swfid = sw.open('swath.hdf');
swathID = sw.attach(swfid,'Example Swath');
[fields,rank,datatypes] = sw.inqGeoFields(swathID);
sw.detach(swathID);
sw.close(swfid);
```

See Also `sw.defGeoField` | `sw.inqDataFields`

- Purpose** Information about swath indexed geolocation mapping
- Syntax** `[idxMap,idxSize] = inqIdxMaps(swathID)`
- Description** `[idxMap,idxSize] = inqIdxMaps(swathID)` retrieves all indexed geolocation/data mappings defined in the swath. `idxMap` is a cell array with each element consisting of the names of the dimensions of a mapping, separated by a `'/'`. `idxSize` contains the size of the index arrays corresponding to each mapping.
- This function corresponds to the `SWinqidxmaps` routine in the HDF-EOS library.
- See Also** `sw.inqMaps`

matlab.io.hdfEOS.sw.inqMaps

Purpose Information about swath geolocation relations

Syntax `[map,offset,increment] = inqMaps(swathID)`

Description `[map,offset,increment] = inqMaps(swathID)` returns the dimension mapping list, the offset of each geolocation relation, and the increment of each geolocation relation. These mappings are not indexed. `map` is a cell array where each element contains the names of the dimensions for each mapping, separated by a slash. `offset` and `increment` contain the offset and increment of each geolocation relation.

This function corresponds to the `SWinqmaps` routine in the HDF-EOS library.

Examples

```
import matlab.io.hdfEOS.*
swfid = sw.open('swath.hdf');
swathID = sw.attach(swfid,'Example Swath');
[dimmap,offset,increment] = sw.inqMaps(swathID);
sw.detach(swathID);
sw.close(swfid);
```

See Also `sw.inqDims` | `sw.defDimMap` | `sw.inqIdxMaps`

Purpose

Names of swaths in file

Syntax

```
swaths = inqSwath(filename)
```

Description

`swaths = inqSwath(filename)` returns a cell array containing the names of all the swaths in a file.

This function corresponds to the `SWinqswath` function in the HDF-EOS library C API.

Examples

```
import matlab.io.hdfeos.*  
swaths = sw.inqSwath('swath.hdf');
```

See Also

`gd.inqGrid`

matlab.io.hdfEOS.sw.mapInfo

Purpose Offset and increment of specific geolocation mapping

Syntax [offset,increment] = mapInfo(swathID,geodim,datadim)

Description [offset,increment] = mapInfo(swathID,geodim,datadim) retrieves the offset and increment of the geolocation mapping between the specified geolocation dimension and the specified data dimension.

This function corresponds to the SWmapinfo function in the HDF-EOS C library API.

Examples

```
import matlab.io.hdfEOS.*
swfid = sw.open('myfile.hdf','create');
swathID = sw.create(swfid,'MySwath');
sw.defDim(swathID,'GeoTrack',2000);
sw.defDim(swathID,'GeoXtrack',1000);
sw.defDim(swathID,'DataTrack',4000);
sw.defDim(swathID,'DataXtrack',2000);
sw.defDimMap(swathID,'GeoTrack','DataTrack',0,2);
sw.defDimMap(swathID,'GeoXtrack','DataXtrack',1,2);
sw.detach(swathID);
sw.close(swfid);
swfid = sw.open('myfile.hdf','read');
swathID = sw.attach(swfid,'MySwath');
[offset,increment] = sw.mapInfo(swathID,'GeoTrack','DataTrack');
sw.detach(swathID);
sw.close(swfid);
```

See Also

sw.defDimMap

Purpose

Number of entries for specific type

Syntax

```
nEnts = nEntries(swathID,type)
```

Description

`nEnts = nEntries(swathID,type)` returns the number of entries in a swath. Valid inputs for type include:

| | |
|--------------|--------------------|
| 'dims' | or 'HDFE_NENTDIM' |
| 'maps' | or 'HDFE_NENTMAP' |
| 'imaps' | or 'HDFE_NENTIMAP' |
| 'geofields' | or 'HDFE_NENTGFLD' |
| 'datafields' | or 'HDFE_NENTFLD' |

This function corresponds to the `SWnentries` function in the HDF-EOS library C API.

Examples

```
import matlab.io.hdfEOS.*  
swfid = sw.open('myfile.hdf','create');  
swathID = sw.create(swfid,'MySwath');  
sw.defDim(swathID,'GeoTrack',2000);  
sw.defDim(swathID,'GeoXtrack',1000);  
sw.defDim(swathID,'DataTrack',4000);  
sw.defDim(swathID,'DataXtrack',2000);  
ndims = sw.nEntries(swathID,'dims');  
sw.detach(swathID);  
sw.close(swfid);
```

matlab.io.hdfEOS.sw.open

Purpose Open swath file

Syntax
`swfID = open(filename)`
`swfID = open(filename,access)`

Description `swfID = open(filename)` opens an HDF-EOS swath file for read-only access.

`swfID = open(filename,access)` opens or creates an HDF-EOS swath file identified by `filename` and returns a file ID. `access` can be one of the following string values.

| | |
|-------------------------------|--|
| <code>'read'</code> (default) | Read-only |
| <code>'rdwr'</code> | Read-write |
| <code>'create'</code> | Creates a file, deleting it if it already exists |

This routine corresponds to the `SWopen` function in the HDF-EOS library C API.

Examples

```
import matlab.io.hdfEOS.*  
swfid = sw.open('swath.hdf');  
sw.close(swfid);
```

See Also `sw.close`

Purpose

Information about subsetted period

Syntax

```
[datatype,dims] = periodInfo(swathID,periodID,fieldname)
```

Description

[datatype,dims] = periodInfo(swathID,periodID,fieldname) retrieves information about the period defined for the given field. datatype is the data type of the field. dims is the dimensions of the subsetted region.

This function corresponds to the SWperiodinfo function in the HDF-EOS library C API, but because MATLAB uses FORTRAN-style ordering, the dims parameter is reversed with respect to the C library API.

Examples

```
import matlab.io.hdfEOS.*  
swfid = sw.open('swath.hdf');  
swathID = sw.attach(swfid,'Example Swath');  
starttime = 25;  
stoptime = 425;  
periodID = sw.defTimePeriod(swathID,starttime,stoptime,'MIDPOINT');  
[ntype,dims] = sw.periodInfo(swathID,periodID,'Temperature');  
sw.detach(swathID);  
sw.close(swfid);
```

See Also

sw.defTimePeriod | sw.extractPeriod

matlab.io.hdfEOS.sw.readAttr

Purpose Read swath attribute

Syntax `data = readAttr(swathID,attrname)`

Description `data = readAttr(swathID,attrname)` reads a swath attribute. This function corresponds to the `SWreadAttr` function in the HDF-EOS library C API.

Examples

```
import matlab.io.hdfEOS.*
swfid = sw.open('swath.hdf');
swathID = sw.attach(swfid,'Example Swath');
value = sw.readAttr(swathID,'creation_date');
sw.detach(swathID);
sw.close(swfid);
```

See Also `sw.writeAttr`

Purpose Read data from swath field

Syntax

```
data = readField(swathID,fieldname)
data = readField(swathID,fieldname,start,count)
data = readField(swathID,fieldname,start,count,stride)
```

Description

`data = readField(swathID,fieldname)` reads an entire swath field.

`data = readField(swathID,fieldname,start,count)` reads a contiguous hyperslab of data from the swath field `fieldname`. The `start` input specifies the zero-based index of the first element to be read. `count` specifies the number of elements along each dimension to read.

`data = readField(swathID,fieldname,start,count,stride)` reads a strided hyperslab of data from the swath field `fieldname`. The `stride` input specifies the inter-element spacing along each dimension.

This function corresponds to the `SWreadfield` function in the HDF-EOS library C API, but because MATLAB uses FORTRAN-style ordering, the `start`, `count`, and `stride` parameters are reversed with respect to the C library API.

Examples

```
import matlab.io.hdfEOS.*
swfid = sw.open('swath.hdf');
swathID = sw.attach(swfid,'Example Swath');
data = sw.readField(swathID,'Longitude');
sw.detach(swathID);
sw.close(swfid);
```

See Also `sw.writeField`

matlab.io.hdfeos.sw.regionInfo

Purpose Information about subsetted region

Syntax [datatype,extent] = regionInfo(swathID,regionID,fieldname)

Description [datatype,extent] = regionInfo(swathID,regionID,fieldname) returns the data type and extent of a subsetted region of a field. regionID is the identifier for the subsetted region.

This function corresponds to the SWregioninfo function in the HDF-EOS library C API, but because MATLAB uses FORTRAN-style ordering, the extent parameter is reversed with respect to the C library API.

Examples

```
import matlab.io.hdfeos.*
swfid = sw.open('swath.hdf');
swathID = sw.attach(swfid,'Example Swath');
lat = [34 44];
lon = [16 24];
regionID = sw.defBoxRegion(swathID,lat,lon,'MIDPOINT');
[ntype,dims] = sw.regionInfo(swathID,regionID,'Temperature');
sw.detach(swathID);
sw.close(swfid);
```

See Also sw.defBoxRegion | sw.defVrtRegion

Purpose

Set fill value for the specified field

Syntax

```
setFillValue(swathID,fieldname,fillvalue)
```

Description

`setFillValue(swathID,fieldname,fillvalue)` sets the fill value for the specified field. The field must have more than two dimensions.

This function corresponds to the `SWsetfillvalue` function in the HDF-EOS library C API.

Examples

```
import matlab.io.hdfEOS.*
swfid = sw.open('myfile.hdf','create');
swathID = sw.create(swfid,'MySwath');
sw.defDim(swathID,'Track',400);
sw.defDim(swathID,'Xtrack',200);
dims = {'Track','Xtrack'};
sw.defDataField(swathID,'Temperature',dims,'float');
sw.setFillValue(swathID,'Temperature',single(-999));
sw.detach(swathID);
sw.close(swfid);
```

See Also

`sw.setFillValue`

matlab.io.hdfEOS.sw.writeAttr

Purpose Write swath attribute

Syntax writeAttr(swathID,attrname,data)

Description writeAttr(swathID,attrname,data) writes an attribute to a swath. If the attribute does not exist, it is created. If the attribute exists, it can be modified in place, but it cannot be recreated with a different data type or length.

This function corresponds to the SWwriteattr function in the HDF-EOS library C API.

Examples

```
import matlab.io.hdfEOS.*
swfid = sw.open('myfile.hdf','create');
swathID = sw.create(swfid,'MySwath');
sw.writeAttr(swathID,'creation_date', datestr(now));
sw.detach(swathID);
sw.close(swfid);
```

See Also sw.readAttr

Purpose

Write data to swath field

Syntax

```
writeField(swathID,fieldname,data)
writeField(swathID,fieldname,start,data)
writeField(swathID,fieldname,start,stride,data)
```

Description

`writeField(swathID,fieldname,data)` writes an entire swath data field.

`writeField(swathID,fieldname,start,data)` writes a contiguous hyperslab to a swath field. `start` specifies the index of the first element to write. The number of elements along each dimension is inferred from either the size of `data` or from the swath field itself.

`writeField(swathID,fieldname,start,stride,data)` writes a strided hyperslab to a swath field. `stride` specifies the inter-element spacing along each dimension.

This function corresponds to the `SWwritefield` function in the HDF-EOS library C API, but because MATLAB uses FORTRAN-style ordering, the `start` and `stride` parameters are reversed with respect to the C library API.

Examples

Write data to a geolocation field 'Longitude'.

```
lon = [-50:49];
data = repmat(lon(:),1,100);
data = single(data);
import matlab.io.hdfEOS.*
srcFile = fullfile(matlabroot,'toolbox','matlab','imagesci','swath.hdf');
copyfile(srcFile,'myfile.hdf');
fileattrib('myfile.hdf','+w');
swfid = sw.open('myfile.hdf','rdwr');
swathID = sw.attach(swfid,'Example Swath');
sw.writeField(swathID,'Longitude',data);
sw.detach(swathID);
sw.close(swfid);
```

matlab.io.hdfEOS.sw.writeField

See Also

`sw.readField`

Purpose

Save workspace variables to MATLAB script

Syntax

```
matlab.io.saveVariablesToScript(filename)
matlab.io.saveVariablesToScript(filename,varnames)
matlab.io.saveVariablesToScript(filename,Name,Value)
[r1,r2] = matlab.io.saveVariablesToScript(filename)
```

Description

`matlab.io.saveVariablesToScript(filename)` saves variables in the current workspace to a MATLAB script named `filename.m`. The `filename` can include the `.m` suffix. If you do not include it, the function adds it when it creates the file.

Variables that MATLAB cannot generate code for are saved to a MAT-file named `filename.mat`.

If a file with the same name already exists, it is overwritten.

`matlab.io.saveVariablesToScript(filename,varnames)` saves only workspace variables specified by `varnames` to the MATLAB script.

`matlab.io.saveVariablesToScript(filename,Name,Value)` uses additional options specified by one or more `Name,Value` pair arguments.

`[r1,r2] = matlab.io.saveVariablesToScript(filename)` additionally returns two cell arrays:

- `r1` for variables that were saved to the MATLAB script
- `r2` for variables that were saved to a MAT-file

Input Arguments

filename - Name of MATLAB script for saving variables

`filename` | variable

Name of MATLAB script for saving variables, specified as a string giving a file name or a variable containing the file name.

Example: `matlab.io.saveVariablesToScript('myVariables.m')`

matlab.io.saveVariablesToScript

varnames - Name of variables to save

string | cell array

Name of variables to save, specified as a string or a cell array.

Example: {'X','Y','Z'}

Data Types

char | cell

Name-Value Pair Arguments

Specify optional comma-separated pairs of `Name`, `Value` arguments. `Name` is the argument name and `Value` is the corresponding value. `Name` must appear inside single quotes (' '). You can specify several name and value pair arguments in any order as `Name1,Value1,...,NameN,ValueN`.

Example: `'MaximumArraySize',500,'MATFileVersion','v4'` specifies that the maximum number of array elements to save is 500 using MATLAB version 4 syntax.

'MATFileVersion' - MATLAB version whose syntax to use

'v7.3' (default) | 'v4' | 'v6' | 'v7'

MATLAB version whose syntax to use for saving MAT-files, specified as the comma-separated pair consisting of `'MATFileVersion'` and one of the following version numbers:

- 'v4'
- 'v6'
- 'v7'
- 'v7.3'

Example: `'MATFileVersion','v6'`

Data Types

char

'MaximumArraySize' - Maximum array elements to save

1000 (default) | integer

Maximum array elements to save, specified as the comma-separated pair consisting of 'MaximumArraySize' and an integer in the range of 1 to 10,000.

Example: 'MaximumArraySize',1050

'MaximumNestingLevel' - Maximum number of object levels or array hierarchies to save

20 (default) | integer

Maximum number of object levels or array hierarchies to save, specified as the comma-separated pair consisting of 'MaximumNestingLevel' and an integer in the range of 1 to 200.

Example: 'MaximumNestingLevel',67

'MaximumTextWidth' - Text wrap width during save

76 (default) | integer

Text wrap width during save, specified as the comma-separated pair consisting of 'MaximumTextWidth' and an integer in the range of 32 to 256.

Example: 'MaximumTextWidth',82

'MultidimensionalFormat' - Dimensions of 2-D slices that represent n-D arrays of char, logic, or numeric data

'rowvector' (default) | integer cell array

Dimensions of 2-D slices that represent n-D arrays of char, logic, or numeric data, specified as the comma-separated pair consisting of 'MultidimensionalFormat' and one of these values:

- 'rowvector' — Save multidimensional variables as a single row vector.
- integer cell array — Save a 2-D slice of multidimensional variables, where the dimensions satisfy all the following criteria:
 - Two positive integers represent dimensions.

matlab.io.saveVariablesToScript

- The two integers are less than or equal to the dimensions of the n-D array.
- The second integer is greater than the first.

Example: `'MultidimensionalFormat',[1,3]`

'RegExp' - Regular expression for matching

string

Regular expression for matching, specified as the comma-separated pair consisting of 'RegExp' and one or more expressions given as a string.

Example: `'RegExp','level*'`

Data Types

char

'SaveMode' - Mode to save MATLAB script

`'create'` (default) | `'update'` | `'append'`

Mode to save MATLAB script, specified as the comma-separated pair consisting of SaveMode and one of these values:

- `'create'` — Save variables to a new MATLAB script.
- `'update'` — Only update variables that are already present in a MATLAB script.
- `'append'` — Update variables that are already present in a MATLAB script and append new variables to the end of the script.

Example: `'SaveMode','Update'`

Output Arguments

r1 - Variables that were saved to a MATLAB script

cell array

Variables that were saved to a MATLAB script, returned as a cell array of variable names.

r2 - Variables that were saved to a MAT-file

cell array

Variables that were saved to a MAT-file, returned as a cell array of variable names.

Examples

Save Workspace Variables to MATLAB Script

Save variables from a workspace to a MATLAB script, `test.m`.

```
matlab.io.saveVariablesToScript('test.m')
```

Save Specific Workspace Variables to MATLAB Script

Create and save variable `myVar` from a workspace to a MATLAB script, `test.m`.

```
myVar = 55.3;  
matlab.io.saveVariablesToScript('test.m','myVar')
```

Append Specific Variables to Existing MATLAB Script

Create two variables, `a` and `b`, and save them to an existing MATLAB script `abfile.m`.

```
a = 72.3;  
b = pi;  
matlab.io.saveVariablesToScript('abfile.m',{'a','b'},...  
'SaveMode','append')
```

Update Specific Variables in Existing MATLAB Script

Update and save two variables, `y` and `z`, to an existing MATLAB script `yzfile.m`.

```
y = 15.7;  
z = 3 * pi;  
matlab.io.saveVariablesToScript('yzfile.m',{'y','z'},...  
'SaveMode','update')
```

Specify MATLAB Script Configuration for Saving Variable

Update and save variable `resistance` to an existing MATLAB script `designData.m` while specifying the configuration of the script file.

matlab.io.saveVariablesToScript

```
resistance = [10 20.5 11 13.7 15.1 7.7];
matlab.io.saveVariablesToScript('designData.m','resistance',...
    'SaveMode','Update','MaximumArraySize',5,...
    'MaximumNestingLevel',5,'MaximumTextWidth',30)
```

Specify 2-D Slice for Saving 3-D Array in MATLAB Script

Specify a 2-D slice for the output of the 3-D array `my3Dtable`, such that the 2-D slice expands along the first and third dimensions. Save the 2-D slice in the MATLAB script `sliceData.m`.

```
level1 = [1 2; 3 4];
level2 = [5 6; 7 8];
my3Dtable(:, :, 1) = level1;
my3Dtable(:, :, 2) = level2;
matlab.io.saveVariablesToScript('sliceData.m','MultidimensionalFormat',[1,3])
```

The resulting MATLAB code is similar to the following:

```
level1 = ...
    [1 2;
     3 4];

level2 = ...
    [5 6;
     7 8];
my3Dtable = zeros(2, 2, 2);
my3Dtable(:,1,:) = ...
    [1 5;
     3 7];

my3Dtable(:,2,:) = ...
    [2 6;
     4 8];
```

Save Variables Matching a Regular Expression

Save variables that match the expression `autoL*` to a MATLAB script `autoVariables.m`.

```
matlab.io.saveVariablesToScript('autoVariables.m','RegExp','autoL*')
```

Save Variables to Version 7.3 MATLAB Script

Create two variables, p and q, and save them to a version 7.3 MATLAB script version73.m.

```
p = 49;  
q = 35.5;  
matlab.io.saveVariablesToScript('version73.m','p','q',...  
    'MATFileVersion','v7.3')
```

Return Variables Saved to MATLAB Script

Save variables that were saved to a MATLAB script to the variable r1, and those that were saved to a MAT-file to the variable r2.

```
[r1,r2] = matlab.io.saveVariablesToScript('mydata.m')
```

```
r1 =
```

```
    'level1'  
    'level2'  
    'level3'  
    'my3Dtable'
```

```
r2 =
```

```
Empty cell array: 0-by-1
```

Limitations

- `matlab.io.saveVariablesToScript` does not save the following variables to a MATLAB script or a MAT-file.
 - Java objects
 - .NET objects
- `matlab.io.saveVariablesToScript` saves the following variables only to a MAT-file.

matlab.io.saveVariablesToScript

- MATLAB objects
- Function handles
- Anonymous functions

Purpose

Construct unique strings from input strings

Syntax

```
U = matlab.lang.makeUniqueStrings(S)
```

```
U = matlab.lang.makeUniqueStrings(S,excludedStrings)
```

```
U = matlab.lang.makeUniqueStrings(S,whichStrings)
```

```
U = matlab.lang.makeUniqueStrings(S, __ , maxStringLength)
```

```
[U, modified] = matlab.lang.makeUniqueStrings( __ )
```

Description

`U = matlab.lang.makeUniqueStrings(S)` constructs unique strings, `U`, from input strings, `S`, by appending an underscore and a number to duplicate strings.

`U = matlab.lang.makeUniqueStrings(S,excludedStrings)` constructs strings that are unique within `U` and with respect to `excludedStrings`. The `makeUniqueStrings` function does not check `excludedStrings` for uniqueness.

`U = matlab.lang.makeUniqueStrings(S,whichStrings)` specifies the subset of `S` to make unique within the entire set. `makeUniqueStrings` makes the strings in `S(whichStrings)` unique among themselves and with respect to the remaining strings. `makeUniqueStrings` returns the remaining strings unmodified in `U`. Use this syntax when you have an array of strings, and need to check that only some elements of the array are unique.

`U = matlab.lang.makeUniqueStrings(S, __ , maxStringLength)` specifies the maximum length, `maxStringLength`, of strings in `U`. If `makeUniqueStrings` cannot make elements in `S` unique without exceeding `maxStringLength`, it returns an error. You can use this syntax with any of the input arguments of the previous syntaxes.

`[U, modified] = matlab.lang.makeUniqueStrings(__)` returns a logical array, `modified`, indicating modified strings.

matlab.lang.makeUniqueStrings

Input Arguments

S - Input strings

string or cell array of strings

Input strings, specified as a string or cell array of strings.

excludedStrings - Strings to exclude

string or cell array of strings

Strings to exclude from U, specified as a string or cell array of strings.

Example: 'dontDuplicateThisString',
{'excludeS1','excludeS2'}, who

whichStrings - Subset of strings to make unique

range of linear indices or logical array

Subset of strings, S, to make unique within the entire set, specified as a range of linear indices or as a logical array with the same size and shape as S. If there are duplicates in S, the makeUniqueStrings function only modifies those specified by whichStrings.

If whichStrings is a logical array, strings are checked for uniqueness when the array element in the same position has a value of true.

Example: 1:5, logical([1 0 1]), [true false true]

maxStringLength - Maximum length of output strings

integer

Maximum length of output strings in U, specified as an integer. If makeUniqueStrings cannot make elements in S unique without exceeding maxStringLength, it returns an error.

Output Arguments

U - Unique strings

string | cell array of strings

Unique strings, returned as a string or cell array of strings. The output has the same dimension as the input, S.

modified - Indicator of modified strings

logical scalar | logical array

Indicator of modified strings, returned as a logical scalar or array and having the same dimension as the input, S. A value of 1 (true) indicates that `makeUniqueStrings` modified the input string in the corresponding location. A value of 0 (false) indicates that `makeUniqueStrings` did not need to modify the input string in the corresponding location.

Examples

Construct Unique Strings

Create an array of strings and make each element unique.

```
S = {'John' 'Sue' 'Nick' 'John' 'Campion' 'John' 'Jason'};  
U = matlab.lang.makeUniqueStrings(S)
```

```
U =
```

```
    'John'    'Sue'    'Nick'    'John_1'    'Campion'    'John_2'
```

The `makeUniqueStrings` function appends the duplicate strings in elements 3 and 5 with underscores and incrementing numbers.

Construct Unique Strings and Specify Exclusions

Without specifying excluded strings, make the strings in U unique.

```
S = {'John' 'Sue' 'Nick' 'John' 'Campion' 'John' 'Jason'};  
U = matlab.lang.makeUniqueStrings(S)
```

```
U =
```

```
    'John'    'Sue'    'Nick'    'John_1'    'Campion'    'John_2'
```

Specify that the string, 'Nick', should be excluded from the output.

```
U = matlab.lang.makeUniqueStrings(S, 'Nick')
```

matlab.lang.makeUniqueStrings

```
U =  
    'John'    'Sue'    'Nick_1'    'John_1'    'Campion'    'John_2'
```

`makeUniqueStrings` excludes 'Nick' from U and instead modifies the first duplicate string, found in element 3, to be 'Nick_1'.

Exclude workspace variables from the unique string array.

```
Sue = 42;  
U = matlab.lang.makeUniqueStrings(S, who)
```

```
U =  
    'John'    'Sue_1'    'Nick'    'John_1'    'Campion'    'John_2'
```

Since 'Sue' exists in the workspace, `makeUniqueStrings` makes this string unique by appending an underscore and number.

Construct Unique Strings for Specified Array Elements

Create an array of strings and make only the first four elements unique.

```
S = {'quiz' 'quiz' 'quiz' 'exam' 'quiz' 'exam'};  
U = matlab.lang.makeUniqueStrings(S, 1:4)
```

```
U =  
    'quiz_1'    'quiz_2'    'quiz_3'    'exam_1'    'quiz'    'exam'
```

The first four elements in `U` are unique among themselves, and among the remaining strings in elements 5 and 6 ('quiz' and 'exam'). Alternatively, you can use a logical array instead of a range of linear indices to achieve the same results: `U = matlab.lang.makeUniqueStrings(S, [true true true true false false])` or `U = matlab.lang.makeUniqueStrings(S, logical([1 1 1 1 0 0]))`.

Append a duplicate 'quiz' onto the end of `S` and make the first four elements unique.

```
S{end+1} = 'quiz'  
U = matlab.lang.makeUniqueStrings(S, 1:4)
```

```
S =
```

```
    'quiz'    'quiz'    'quiz'    'exam'    'quiz'    'exam'    'quiz'
```

```
U =
```

```
    'quiz_1'    'quiz_2'    'quiz_3'    'exam_1'    'quiz'    'exam'
```

The strings that `makeUniqueStrings` checks are still unique among themselves and among the remaining strings. Since `makeUniqueStrings` does not check any elements after element 4, duplicate strings remain.

Construct Unique Strings with Maximum Length

Create an array from `S` where the first three elements are unique and the maximum length of each string is 5.

```
S = {'sampleData' 'sampleData' 'sampleData' 'sampleData'};  
U = matlab.lang.makeUniqueStrings(S, 1:3, 5)
```

matlab.lang.makeUniqueStrings

```
U =  
    'sampl'    'sam_1'    'sam_2'    'sampleData'
```

The first element is truncated to 5 characters. The second and third elements are truncated to 3 characters to allow `makeUniqueStrings` to append an underscore and number, and still not exceed 5 characters.

Determine Modified Strings

```
S = {'a%name', 'name_1', '2_name'};  
[N, modified] = matlab.lang.makeValidName(S)
```

```
N =  
    'a_name'    'name_1'    'x2_name'
```

```
modified =  
    1     0     1
```

`makeValidName` did not modify the second element.

Tips

- To ensure strings are valid and unique, use `matlab.lang.makeValidName` before `matlab.lang.makeUniqueStrings`.

```
S = {'my.Name', 'my_Name', 'my_Name'};  
validStrings = matlab.lang.makeValidName(S)  
validUniqueStrings = matlab.lang.makeUniqueStrings(validStrings,...  
    {},nameLengthmax)
```

```
validStrings =
```

```
'my_Name'    'my_Name'    'my_Name'
```

```
validUniqueStrings =
```

```
'my_Name'    'my_Name_1'    'my_Name_2'
```

See Also

[matlab.lang.makeValidName](#) | [namelengthmax](#) | [who](#)

matlab.lang.makeValidName

Purpose Construct valid MATLAB identifiers from input strings

Syntax

```
N = matlab.lang.makeValidName(S)  
N = matlab.lang.makeValidName(S,Name,Value)  
[N, modified] = matlab.lang.makeValidName( ___ )
```

Description `N = matlab.lang.makeValidName(S)` constructs valid MATLAB identifiers, `N`, from input strings, `S`. The `makeValidName` function does not guarantee the strings in `N` are unique.

A valid MATLAB identifier is a string of alphanumerics (A–Z, a–z, 0–9) and underscores, such that the first character is a letter and the length of the string is less than or equal to `namelengthmax`.

`makeValidName` deletes any whitespace characters prior to replacing any characters that are not alphanumerics or underscores. If a whitespace character is followed by a lowercase letter, `makeValidName` converts the letter to the corresponding uppercase character.

`N = matlab.lang.makeValidName(S,Name,Value)` includes additional options specified by one or more `Name,Value` pair arguments.

`[N, modified] = matlab.lang.makeValidName(___)` returns a logical array, `modified`, indicating modified strings. You can use this syntax with any of the input arguments of the previous syntaxes.

Input Arguments

S - Input strings
string or cell array of strings

Input strings, specified as a string or cell array of strings. If `S` is a cell array of strings, it must be a 1xN or Nx1 cell array.

Name-Value Pair Arguments

Specify optional comma-separated pairs of `Name,Value` arguments. `Name` is the argument name and `Value` is the corresponding value. `Name` must appear inside single quotes (' '). You can

specify several name and value pair arguments in any order as `Name1, Value1, ..., NameN, ValueN`.

Example: `'ReplacementStyle', 'delete'` deletes invalid characters.

'ReplacementStyle' - Replacement style

`'underscore'` (default) | `'delete'` | `'hex'`

Replacement style, specified as a string. The value controls how MATLAB replaces nonalphanumeric characters.

| ReplacementStyle Value | Description |
|-------------------------------------|---|
| <code>'underscore'</code> (default) | Replaces all characters that are not alphanumeric or underscores with underscores. <code>'underscore'</code> deletes whitespace characters and changes a lowercase letter following a whitespace to uppercase. |
| <code>'hex'</code> | Replaces each character that is not an alphanumeric or underscore with its corresponding hexadecimal representation. <code>'hex'</code> deletes whitespace characters and changes a lowercase letter following a whitespace to uppercase. |
| <code>'delete'</code> | Deletes all characters that are not alphanumerics or underscores. <code>'delete'</code> deletes whitespace characters and changes any lowercase letter following a whitespace to uppercase. |

'Prefix' - Character to prefix

`'x'` (default) | string

Character to prefix to input strings that do not begin with a letter after `makeValidName` replaces nonalphanumeric characters, specified as a string. A valid prefix must start with a letter, contain only alphanumeric characters and underscores, and not be longer than the value of `namelengthmax`.

matlab.lang.makeValidName

Output Arguments

N - Valid MATLAB identifiers

string | cell array of strings

Valid MATLAB identifiers, returned as a string or cell array of strings. The output has the same number of dimensions as the input, S.

modified - Indicator of modified strings

logical scalar | logical array

Indicator of modified strings, returned as a logical scalar or array and having the same number of dimensions as the input, S. A value of 1 (true) indicates that makeValidName modified the input string in the corresponding location. A value of 0 (false) indicates that makeValidName did not need to modify the input string in the corresponding location.

Examples

Construct Valid MATLAB Identifiers

```
S = {'Item_#','Price/Unit','1st order','Contact'};  
N = matlab.lang.makeValidName(S)
```

```
N =
```

```
    'Item__'    'Price_Unit'    'x1stOrder'    'Contact'
```

In the first and second strings, makeValidName replaced the invalid characters (# and /), with underscores. In the third string, makeValidName appended a prefix because the string doesn't begin with a letter, deleted the empty space, and capitalized the character following the deleted space.

Construct Valid MATLAB Identifiers Using Specified Replacement Style

Replace invalid characters with the corresponding hexadecimal representation.

```
S = {'Item_#','Price/Unit','1st order','Contact'};  
N = matlab.lang.makeValidName(S,'ReplacementStyle','hex')
```

```
N =
```

```
    'Item_0x23'    'Price0x2FUnit'    'x1stOrder'    'Contact'
```

In the first and second strings, `makeValidName` replaced the invalid characters (# and /), with their hexadecimal representation. In the third string, `makeValidName` appended a prefix because the string doesn't begin with a letter, deleted the empty space, and capitalized the character following the deleted space.

Delete invalid characters.

```
N = matlab.lang.makeValidName(S,'ReplacementStyle','delete')
```

```
N =
```

```
    'Item_'    'PriceUnit'    'x1stOrder'    'Contact'
```

`makeValidName` deleted the invalid characters (# and /). In the third string, `makeValidName` appended a prefix because the string doesn't begin with a letter, deleted the empty space, and capitalized the character following the deleted space.

Construct Valid MATLAB Identifiers Using Specified Prefix

```
S = {'1stMeasurement','2ndMeasurement','Control'};  
N = matlab.lang.makeValidName(S,'Prefix','m_')
```

```
N =
```

matlab.lang.makeValidName

```
'm_1stMeasurement'    'm_2ndMeasurement'    'Control'
```

Only the strings that do not start with a letter are prepended with a prefix.

Determine Modified Strings

```
S = {'a%name', 'name_1', '2_name'};  
[N, modified] = matlab.lang.makeValidName(S)
```

```
N =
```

```
'a_name'    'name_1'    'x2_name'
```

```
modified =
```

```
1     0     1
```

makeValidName did not modify the second element.

Tips

- To ensure strings are valid and unique, use `matlab.lang.makeUniqueStrings` after `matlab.lang.makeValidName`.

```
S = {'my.Name', 'my_Name', 'my_Name'};  
validStrings = matlab.lang.makeValidName(S)  
validUniqueStrings = matlab.lang.makeUniqueStrings(validStrings, {}, ...  
    namelengthmax)
```

```
validStrings =
```

```
'my_Name'    'my_Name'    'my_Name'
```



```
validUniqueStrings =  
  
    'my_Name'    'my_Name_1'    'my_Name_2'
```

- To customize an invalid character replacement, first use functions such as `strrep` or `regexprep` to convert to valid characters. For example, convert '@' characters in the string, `S`, to 'At' using `strrep(S, '@', 'At')`. Then, use `matlab.lang.makeValidName` to ensure that all characters in the strings are valid.

See Also

`matlab.lang.makeUniqueStrings` | `isvarname` | `iskeyword` | `isletter` | `namelengthmax` | `who` | `strrep` | `regexp` | `regexprep`

Purpose

Startup file for MATLAB program

Description

At startup time, MATLAB automatically executes the file `matlabrc.m`. This function establishes the MATLAB path, sets the default figure size, and sets some uicontrol defaults.

On multiuser or networked systems, system administrators can put messages, definitions, or other code that applies to all users in their `matlabrc.m` file.

The file `matlabrc.m` invokes the `startup.m` file, if it exists on the search path MATLAB uses.

Individual users should use the `startup.m` file to customize MATLAB startup. The `matlabrc.m` file, located in the `matlabroot/toolbox/local` folder, is reserved for system administrators.

Algorithms

MATLAB invokes `matlabrc` at startup. `matlabrc.m` contains the statements

```
if exist('startup') == 2
    startup
end
```

that invokes `startup.m`, if it exists. Extend this process to create additional startup files, if required.

Tips

You can also start MATLAB using options you define at the Command Window prompt or in your Microsoft Windows shortcut for MATLAB.

Examples

Turning Off the Figure Window Toolbar

If you do not want the toolbar to appear in the figure window, remove the comment marks from the following line in the `matlabrc.m` file, or create a similar line in your own `startup.m` file.

```
% set(0,'defaultfiguretoolbar','none')
```

See Also matlabroot | quit | restoredefaultpath | startup

How To • Startup Options

matlabroot

Purpose Root folder

Syntax matlabroot
mr = matlabroot

Description matlabroot returns the name of the folder where the MATLAB software is installed. Use matlabroot to create a path to MATLAB and toolbox folders that does not depend on a specific platform, MATLAB version, or installation location.

mr = matlabroot returns the name of the folder in which the MATLAB software is installed and assigns it to mr.

Tips **matlabroot as Folder Name**

The term *matlabroot* also refers to the folder where MATLAB files are installed. For example, “save to *matlabroot/toolbox/local*” means save to the *toolbox/local* folder in the MATLAB root folder.

Using \$matlabroot as a Literal

In some files, \$matlabroot is literal. In those files, MATLAB interprets \$matlabroot as the full path to the MATLAB root folder. For example, including the line:

```
$matlabroot/toolbox/local/myfile.jar
```

in *javaclasspath.txt*, adds *myfile.jar*, which is located in the *toolbox/local* folder, to the static Java class path.

Sometimes, particularly in older code examples, the term \$matlabroot or \$MATLABROOT is not meant to be interpreted literally but is used to represent the value returned by the *matlabroot* function.

matlabroot on Macintosh Platforms

In R2008b (V7,7) and more recent versions, running *matlabroot* on Apple Macintosh platforms returns

```
/Applications/MATLAB_R2008b.app
```

In versions prior to R2008b (V7.7), such as R2008a (V7.6), running `matlabroot` on Macintosh platforms returns, for example

```
/Applications/MATLAB_R2008a
```

When you use GUIs on Macintosh platforms, you cannot directly view the contents of the MATLAB root folder. For more information, see “Navigating Within the MATLAB Root Folder on Macintosh Platforms”.

Examples

Get the location where MATLAB is installed:

```
matlabroot
```

MATLAB returns:

```
C:\Program Files\MATLAB\R2009a
```

Produce a full path to the `toolbox/matlab/general` folder that is correct for the platform on which it is executed:

```
fullfile(matlabroot,'toolbox','matlab','general')
```

Change the current folder to the MATLAB root folder:

```
cd(matlabroot)
```

To add the folder `myfiles` to the MATLAB search path, run

```
addpath([matlabroot '/toolbox/local/myfiles'])
```

See Also

`fullfile` | `path` | `toolboxdir`

matlab (UNIX)

Purpose Start MATLAB program (UNIX platforms)

Syntax

```
matlab
matlab helpOption
matlab envDispOption
matlab archOption
matlab dispOption
matlab modeOption
matlab -c licensefile
matlab -debug
matlab -Ddebugger options
matlab -jdb portnumber
matlab -logfile filename
matlab -mwvisual visualid
matlab -noFigureWindows
matlab -nosplash
matlab -nouserjavapath
matlab -r "command"
matlab -singleCompThread
```

Note You can enter more than one of these options in the same `matlab` command. If you use `-Ddebugger` to start MATLAB in debug mode, the first option in the command must be `-Ddebugger`.

Description `matlab` is a Bourne shell script that starts the MATLAB executable on UNIX platforms. (In this document, `matlab` refers to this script; MATLAB refers to the application program). Before actually initiating the execution of MATLAB, this script configures the run-time environment by:

- Determining the MATLAB root folder
- Determining the host machine architecture
- Processing any command-line options
- Reading the MATLAB startup file, `.matlab7rc.sh`

- Setting MATLAB environment variables

There are two ways in which you can control the way the `matlab` script works:

- By specifying command-line options
- By assigning values in the MATLAB startup file, `.matlab7rc.sh`

Specifying Options at the Command Line

Note On Apple Macintosh platforms, the `matlab` script is located inside the MATLAB application package:

```
/Applications/MATLAB_R2012b.app/bin/matlab
```

To run the `matlab` script from Terminal, specify the full path, or `cd` to the `bin` folder within the application package and preface the command with `./` characters. For example:

```
./matlab -nojvm -nodisplay -nosplash -r "myfun(10,30)"
```

Options that you can enter at the command line are as follows:

`matlab helpOption` displays information that matches the specified `helpOption` argument without starting MATLAB. `helpOption` can be any one of the keywords shown in the following table. Enter only one `helpOption` keyword in a `matlab` command.

Values for helpOption

| Option | Description |
|--------------------|--|
| <code>-help</code> | Display <code>matlab</code> command usage. |
| <code>-h</code> | The same as <code>-help</code> . |

matlab (UNIX)

`matlab envDispOption` displays the values of environment variables passed to MATLAB or their values when exiting MATLAB. `envDispOption` can be either one of the options shown in the following table.

Values for `envDispOption`

| Option | Description |
|-----------|--|
| -n | Display all the final values of the environment variables and arguments passed to the MATLAB executable as well as other diagnostic information. Does not start MATLAB. |
| -e | Display <i>all</i> environment variables and their values before exiting. This argument must have been parsed before exiting for anything to be displayed. The last possible exiting point is just before the MATLAB image would have been executed and a status of 0 is returned. If the exit status is not 0 on return, then the variables and values might not be correct. Does not start MATLAB. |

`matlab archOption` starts MATLAB and assumes that you are running on the system architecture specified by `arch`, or using the MATLAB version specified by `variant`, or both. The values for the `archOption` argument are shown in the following table. Enter only one of these options in a `matlab` command.

Values for archOption

| Option | Description |
|-----------------------------|---|
| <code>-arch</code> | Run MATLAB assuming this architecture rather than the actual architecture of the machine you are using. Replace the term <i>arch</i> with a string representing a recognized system architecture. For example:

<code>matlab -glnx86</code> |
| <code>v=variant</code> | Execute the version of MATLAB found in the folder <code>bin/\$ARCH/variant</code> instead of <code>bin/\$ARCH</code> . Replace the term <i>variant</i> with a string representing a MATLAB version. |
| <code>v=arch/variant</code> | Execute the version of MATLAB found in the folder <code>bin/arch/variant</code> instead of <code>bin/\$ARCH</code> . Replace the terms <i>arch</i> and <i>variant</i> with strings representing a specific architecture and MATLAB version. |

`matlab dispOption` starts MATLAB using one of the display options shown in the following table. Enter only one of these options in a `matlab` command.

Values for dispOption

| Option | Description |
|-----------------------------|---|
| <code>-display xDisp</code> | Send X commands to X Window Server display <code>xDisp</code> . This option supersedes the value of the <code>DISPLAY</code> environment variable.

On Macintosh platforms, this option is ignored. |
| <code>-nodisplay</code> | Start the Oracle JVM software, but do not start the MATLAB desktop. Do not display |

(Continued)

| Option | Description |
|--------|---|
| | any X commands, and ignore the DISPLAY environment variable.

On Macintosh platforms, start the JVM in headless mode, and prevent all windows from being displayed. |

matlab modeOption starts MATLAB without its usual desktop component. Enter only one of the options shown in the following table.

Values for modeOption

| Option | Description |
|-------------------|---|
| -desktop | Allow the MATLAB desktop to be started by a process without a controlling terminal. This is usually a required command-line argument when attempting to start MATLAB from a window manager menu or desktop icon. |
| -nodesktop | Start MATLAB without bringing up the MATLAB desktop. The JVM software <i>is</i> started. To enter commands, use the current window in the operating system. Use this option to run in batch processing mode. If you pipe to MATLAB using the > constructor, the <code>nodesktop</code> option is used automatically. With <code>nodesktop</code> , MATLAB does not save statements to the Command History. With <code>nodesktop</code> , you can still use most development environment tools by starting them via a function. For example, use <code>preferences</code> to open the Preferences dialog box and <code>doc</code> to open the Help browser. Do not use <code>nodesktop</code> to provide a Command Window-only |

(Continued)

| Option | Description |
|---------------|--|
| | interface; instead, select Desktop > Desktop Layout > Command Window Only . |
| -nojvm | Start MATLAB without the JVM software. To enter commands, use the current window. The MATLAB desktop does not open. Any tools that require Java software, such as the desktop tools, cannot be used. Handle Graphics and related functionality are not supported; MATLAB produces a warning when you use them. |

`matlab -c licensefile` starts MATLAB using the specified license file. The `licensefile` argument can have the form `port@host` or it can be a colon-separated list of license filenames. This option causes the `LM_LICENSE_FILE` and `MLM_LICENSE_FILE` environment variables to be ignored.

`matlab -debug` starts MATLAB and displays debugging information that can be useful, especially for X based problems. Use this option only when working with a Technical Support Representative from The MathWorks, Inc.

`matlab -Ddebugger options` starts MATLAB in debug mode, using the named debugger (for example, `dbx`, `gdb`, `xdb`, `cvd`, `lldb`). A full path can be specified for debugger.

Notes for -Ddebugger Argument

- The options argument can include *only* those options that follow the debugger name in the syntax of the actual debug command. For most debuggers, there is a limited number of such options. Use options that would normally be passed to the MATLAB executable as parameters of a command inside the debugger (like `run`). Do not use options when running the `matlab` script.

matlab (UNIX)

- If any other `matlab` command options are placed before the `-Ddebugger` argument, they will be handled as if they were part of the options after the `-Ddebugger` argument and are treated as illegal options by most debuggers. The `MATLAB_DEBUG` environment variable is set to the filename part of the debugger argument.
- To customize your debugging session, use a startup file. See your debugger documentation for details.
- For certain debuggers like `gdb`, the `SHELL` environment variable is *always* set to `/bin/sh`.

`matlab -jdb portnumber` starts MATLAB, enabling use of the Java debugger. If you specify a port number, the Java debugger uses that port to communicate with MATLAB. You can specify any port number in the range 0-65535 that is not reserved or currently in use by another application on your system. By default, MATLAB uses port 4444. If you are running multiple MATLAB sessions and want to use the Java debugger, be sure to specify a port number.

`matlab -logfile filename` starts MATLAB and makes a copy of any output to the Command Window in file `log`. The output includes all crash reports.

`matlab -mwvisual visualid` starts MATLAB and uses `visualid` as the default X visual for figure windows. `visualid` is a hexadecimal number that can be found using `xdpyinfo`.

`matlab -noFigureWindows` starts MATLAB, but disables the display of any figure windows in MATLAB.

`matlab -nosplash` starts MATLAB but does not display the splash screen during startup.

`matlab -nouserjavapath` disables `javaclasspath.txt` and `javalibrarypath.txt` files.

`matlab -r "command"` starts MATLAB and executes the specified MATLAB command. Include the command in double quotation marks ("*command*"). If `command` is the name of a MATLAB function or script,

do not specify the file extension. To separate multiple statements, use semicolons or commas.

`matlab -singleCompThread` limits MATLAB to a single computational thread. By default, MATLAB uses the multithreading capabilities of the computer on which it is running.

Specifying Options in the MATLAB Startup File

The `.matlab7rc.sh` shell script contains definitions for a number of variables that the `matlab` script uses. These variables are defined within the `matlab` script, but can be redefined in `.matlab7rc.sh`. When invoked, `matlab` looks for the first occurrence of `.matlab7rc.sh` in the current folder, in the home folder (`$HOME`), and in the `matlabroot/bin` folder, where the template version of `.matlab7rc.sh` is located.

You can edit the template file to redefine information used by the `matlab` script. If you do not want your changes applied system-wide, copy the edited version of the script to your current or home folder. Ensure that you edit the section that applies to your machine architecture.

The following table lists the variables defined in the `.matlab7rc.sh` file. See the comments in the `.matlab7rc.sh` file for more information about these variables.

Variable Options for Startup File

| Variable | Definition and Standard Assignment Behavior |
|----------|---|
| ARCH | The machine architecture.

The value ARCH passed with the <code>-arch</code> or <code>-arch/ext</code> argument to the script is tried first, then the value of the environment variable <code>MATLAB_ARCH</code> is tried next, and finally it is computed. The first one that gives a valid architecture is used. |
| DISPLAY | Linux platforms only. The hostname of the X Window display MATLAB uses for output. |

matlab (UNIX)

| Variable | Definition and Standard Assignment Behavior |
|---|--|
| | The value of <code>Xdisplay</code> passed with the <code>-display</code> argument to the script is used; otherwise, the value in the environment is used. MATLAB ignores <code>DISPLAY</code> if the <code>-nodisplay</code> argument is passed. |
| LD_LIBRARY_PATH
on Linux platforms.

DYLD_LIBRARY_PATH
on Macintosh
platforms. | Final Load library path. The name <code>LD_LIBRARY_PATH</code> is platform-dependent.

The final value is normally a colon-separated list of four sublists, each of which could be empty. The first sublist is defined in <code>.matlab7rc.sh</code> as <code>LDPATH_PREFIX</code> . The second sublist is computed in the script and includes folders inside the MATLAB root folder and relevant Java folders. The third sublist contains any nonempty value of <code>LD_LIBRARY_PATH</code> from the environment possibly augmented in <code>.matlab7rc.sh</code> . The final sublist is defined in <code>.matlab7rc.sh</code> as <code>LDPATH_SUFFIX</code> . |
| LM_LICENSE_FILE | The FLEX lm license variable.

The license file value passed with the <code>-c</code> argument to the script is used; otherwise it is the value set in <code>.matlab7rc.sh</code> . In general, the final value is a colon-separated list of license files and/or <code>port@host</code> entries. The shipping <code>.matlab7rc.sh</code> file starts out the value by prepending <code>LM_LICENSE_FILE</code> in the environment to a default <code>license.file</code> .

Later in the <code>matlab</code> script, if the <code>-c</code> option is not used, the <code>matlabroot/etc</code> folder is searched for the files that start with <code>license.dat.DEMO</code> . These files are assumed to contain demo |

| Variable | Definition and Standard Assignment Behavior |
|--------------|--|
| | licenses and are added automatically to the end of the current list. |
| MATLAB | <p>The MATLAB root folder.</p> <p>The default computed by the script is used unless MATLABdefault is reset in .matlab7rc.sh.</p> <p>Currently MATLABdefault is not reset in the shipping .matlab7rc.sh.</p> |
| MATLAB_DEBUG | <p>Normally set to the name of the debugger.</p> <p>The -Ddebugger argument passed to the script sets this variable. Otherwise, a nonempty value in the environment is used.</p> |
| MATLAB_JAVA | <p>The path to the root of the Java Runtime Environment.</p> <p>The default set in the script is used unless MATLAB_JAVA is already set. Any nonempty value from .matlab7rc.sh is used first, then any nonempty value from the environment. Currently there is no value set in the shipping .matlab67rc.sh, so that environment alone is used.</p> |
| MATLABPATH | <p>The MATLAB search path.</p> <p>The final value is a colon-separated list with the MATLABPATH from the environment prepended to a list of computed defaults. You can add subfolders of userpath to the MATLAB search path upon startup. See userpath for details.</p> |

matlab (UNIX)

| Variable | Definition and Standard Assignment Behavior |
|----------|--|
| SHELL | <p>The shell to use when the “!” or unix command is issued in MATLAB. This value is taken from the environment unless SHELL is reset in <code>.matlab7rc.sh</code>.</p> <p>Another environment variable called <code>MATLAB_SHELL</code> takes precedence over <code>SHELL</code>. MATLAB checks internally for <code>MATLAB_SHELL</code> first and, if empty or not defined, then checks <code>SHELL</code>. If <code>SHELL</code> is also empty or not defined, MATLAB uses <code>/bin/sh</code>. Use an absolute path for the value of <code>MATLAB_SHELL</code>, that is, <code>/bin/sh</code>, not simply <code>sh</code>.</p> <p>Currently, the shipping <code>.matlab7rc.sh</code> file does not reset <code>SHELL</code> and also does not reference or set <code>MATLAB_SHELL</code>.</p> |
| TOOLBOX | <p>Path of the toolbox folder.</p> <p>A nonempty value in the environment is used first. Otherwise, <code>matlabroot/toolbox</code>, computed by the script, is used unless <code>TOOLBOX</code> is reset in <code>.matlab7rc.sh</code>. Currently <code>TOOLBOX</code> is not reset in the shipping <code>.matlab7rc.sh</code>.</p> |

| Variable | Definition and Standard Assignment Behavior |
|-------------|--|
| XAPPLRESDIR | <p>The X application resource folder (Linux systems only).</p> <p>A nonempty value in the environment is used first unless XAPPLRESDIR is reset in <code>.matlab7rc.sh</code>.</p> |
| XKEYSYMDB | <p>The X keysym database file (Linux systems only).</p> <p>A nonempty value in the environment is used first unless XKEYSYMDB is reset in <code>.matlab7rc.sh</code>.</p> |

The `matlab` script determines the path of the MATLAB root folder by looking up the folder tree from the `matlabroot/bin` folder (where the `matlab` script is located). The MATLAB variable is then used to locate all files within the MATLAB folder tree.

You can change the definition of MATLAB if, for example, you want to run a different version of MATLAB or if, for some reason, the path determined by the `matlab` script is not correct. (This can happen when your system uses certain types of automounting schemes.)

See Also

`matlab` (Windows) | `mex`

How To

- “Start MATLAB on Linux Platforms”
- “Start MATLAB on Macintosh Platforms”
- “Startup Options”

matlab (Windows)

Purpose Start MATLAB program (Windows platforms)

Syntax

```
matlab
matlab helpOption
matlab -automation
matlab -c licensefile
matlab -jdb portnumber
matlab -logfile filename
matlab -noFigureWindows
matlab -nosplash
matlab -nouserjavapath
matlab -r "statement"
matlab -regserver
matlab -sd "startdir"
matlab shieldOption
matlab -singleCompThread
matlab -unregserver
matlab -wait
```

Note You can enter more than one of these options in the same `matlab` command.

Description `matlab` is a script that runs the MATLAB executable on Microsoft Windows platforms. (In this document, the term `matlab` refers to the script, and MATLAB refers to the executable). Before actually initiating the execution of MATLAB, it configures the run-time environment by:

- Determining the MATLAB root folder.
- Determining the host machine architecture.
- Selectively processing command line options with the rest passed to MATLAB.
- Setting certain MATLAB environment variables.

There are two ways in which you can control the way `matlab` works:

- By specifying command line options.
- By setting environment variables before calling the program.

Specifying Options at the Command Line

Options that you can enter at the command line are as follows:

`matlab helpOption` displays information that matches the specified *helpOption* argument without starting MATLAB. *helpOption* can be any one of the keywords shown in the table below. Enter only one *helpOption* keyword in a `matlab` statement.

Values for helpOption

| Option | Description |
|--------------|--|
| -help | Display <code>matlab</code> command usage. |
| -h | The same as -help . |
| -? | The same as -help . |

`matlab -automation` starts MATLAB as an automation server. The server window is minimized, and the MATLAB splash screen does not display on startup.

`matlab -c licensefile` starts MATLAB using the specified license file. The `licensefile` argument can have the form `port@host`. This option causes MATLAB to ignore the `LM_LICENSE_FILE` and `MLM_LICENSE_FILE` environment variables.

`matlab -jdb portnumber` starts MATLAB, enabling use of the Java debugger. If you specify a port number, the Java debugger uses that port to communicate with MATLAB. You can specify any port number in the range 0-65535 that is not reserved or currently in use by another application on your system. By default, MATLAB uses port 4444. If you are running multiple MATLAB sessions and want to use the Java debugger, be sure to specify a port number.

matlab (Windows)

`matlab -logfile filename` starts MATLAB and makes a copy of any output to the Command Window in `filename`. This includes all crash reports.

`matlab -noFigureWindows` starts MATLAB, but disables the display of any figure windows in MATLAB.

`matlab -nosplash` starts MATLAB, but does not display the splash screen during startup.

`matlab -nouserjavapath` disables `javaclasspath.txt` and `javalibrarypath.txt` files.

`matlab -r "statement"` starts MATLAB and executes the specified MATLAB statement. If `statement` is the name of a MATLAB function or script, do not specify the file extension. Any required file must be on the MATLAB search path or in the startup folder.

`matlab -regserver` registers MATLAB as a Component Object Model (COM) server.

`matlab -sd "startdir"` specifies the startup folder for MATLAB (the current folder in MATLAB after startup). The `-sd` option has been deprecated. For information about alternatives, see “Startup Folder on Windows Platforms”.

`matlab shieldOption` provides the specified level of protection of the address space used by MATLAB during startup on Windows 32-bit platforms. It attempts to help ensure the largest contiguous block of memory available after startup, which is useful for processing large data sets. The *shieldOption* does this by ensuring resources such as DLLs, are loaded into locations that will not fragment the address space. With *shieldOption* set to a value other than none, address space is protected up to or after the processing of `matlabrc`. Use higher levels of protection to secure larger initial blocks of contiguous memory, however a higher level might not always provide a larger size block and might cause startup problems. Therefore, start with a lower level of protection, and if successful, try the next higher level. You can use the `memory` function after startup to see the size of the largest contiguous block of memory; this helps you determine the actual effect of the *shieldOption* setting

you used. If your `matlabrc` (or `startup.m`) requires significant memory, a higher level of protection for `shieldOption` might cause startup to fail; in that event try a lower level. Values for `shieldOption` can be any one of the keywords shown in the table below.

| Option | Description |
|-------------------------------|---|
| <p>-shield minimum</p> | <p>This is the default setting. It protects the range 0x50000000 to 0x70000000 during MATLAB startup until just before startup processes <code>matlabrc</code>. It ensures there is at least approximately 500 MB of contiguous memory up to this point.</p> <p>Start with this, the default value. To use the default, do not specify a shield option upon startup.</p> <p>If MATLAB fails to start successfully using the default option, -shield minimum, instead use -shield none.</p> <p>If MATLAB starts successfully with the default value for <code>shieldOption</code> and you want to try to ensure an even larger contiguous block after startup, try using the -shield medium option.</p> |
| <p>-shield medium</p> | <p>This protects the same range as for minimum, 0x50000000 to 0x70000000, but protects the range until just after startup processes <code>matlabrc</code>. It ensures there is at least approximately 500 MB of contiguous memory up to this point.</p> <p>If MATLAB fails to start successfully with the -shield medium option, instead use the default option (-shield minimum).</p> |

matlab (Windows)

| Option | Description |
|------------------------|--|
| | If MATLAB starts successfully with the -shield medium option and you want to try to ensure an even larger contiguous block after startup, try using the -shield maximum option. |
| -shield maximum | This protects the maximum possible range, which can be up to approximately 1.5 GB, until just after startup processes <code>matlabrc</code> .

If MATLAB fails to start successfully with the -shield maximum option, instead use the -shield medium option. |
| -shield none | This completely disables address shielding. Use this if MATLAB fails to start successfully with the default (-shield minimum) option. |

`matlab -singleCompThread` limits MATLAB to a single computational thread. By default, MATLAB makes use of the multithreading capabilities of the computer on which it is running.

`matlab -unregserver` removes all MATLAB COM server entries from the registry.

`matlab -wait` MATLAB is started by a separate starter program which normally launches MATLAB and then immediately quits. Using this option tells the starter program not to quit until MATLAB has terminated. This option is useful when you need to process the results from MATLAB in a script. Calling MATLAB with this option blocks the script from continuing until the results are generated.

Setting Environment Variables

You can set the following environment variables before starting MATLAB.

| Variable Name | Description |
|-----------------|---|
| LM_LICENSE_FILE | This variable specifies the License File to use. If you use the -c argument to specify the License File it overrides this variable. The value of this variable can be a list of License Files, separated by semi-colons, or port@host entries. |

See Also

matlab (UNIX) | mex | userpath

How To

- “Start MATLAB on Windows Platforms”
- “Startup Options”

max

Purpose

Largest elements in array

Syntax

```
C = max(A)
C = max(A, [], dim)
[C, I] = max(...)
```

```
C = max(A, B)
```

Description

`C = max(A)` returns the largest elements along different dimensions of an array.

If `A` is a vector, `max(A)` returns the largest element in `A`.

If `A` is a matrix, `max(A)` treats the columns of `A` as vectors, returning a row vector containing the maximum element from each column.

If `A` is a multidimensional array, `max(A)` treats the values along the first non-singleton dimension as vectors, returning the maximum value of each vector.

`C = max(A, [], dim)` returns the largest elements along the dimension of `A` specified by scalar `dim`. For example, `max(A, [], 1)` produces the maximum values along the first dimension of `A`.

`[C, I] = max(...)` finds the indices of the maximum values of `A`, and returns them in output vector `I`. If there are several identical maximum values, the index of the first one found is returned.

`C = max(A, B)` returns an array the same size as `A` and `B` with the largest elements taken from `A` or `B`. The dimensions of `A` and `B` must match, or they may be scalar.

Examples

Return the maximum of a 2-by-3 matrix from each column:

```
X = [2 8 4; 7 3 9];
max(X, [], 1)
ans =
```



```
7     8     9
```

Return the maximum from each row:

```
max(X,[],2)
ans =
```

```
8
9
```

Compare each element of X to a scalar:

```
max(X,5)
ans =
```

```
5     8     5
7     5     9
```

Tips

For complex input A, `max` returns the complex number with the largest complex modulus (magnitude), computed with `max(abs(A))`. Then computes the largest phase angle with `max(angle(x))`, if necessary.

The `max` function ignores NaNs.

See Also

`isnan` | `mean` | `median` | `min` | `sort`

MaximizeCommandWindow

Purpose Open Automation server window

Syntax **IDL Method Signature**

```
HRESULT MaximizeCommandWindow(void)
```

Microsoft Visual Basic Client

```
MaximizeCommandWindow
```

MATLAB Client

```
h.MaximizeCommandWindow  
MaximizeCommandWindow(h)
```

Description h.MaximizeCommandWindow displays the window for the server attached to handle h, and makes it the currently active window on the desktop.

MaximizeCommandWindow(h) is an alternate syntax.

MaximizeCommandWindow restores the window to the size it had at the time it was minimized, not to the maximum size on the desktop. If the server window was not previously in a minimized state, MaximizeCommandWindow does nothing.

Examples From a Visual Basic .NET client, modify the size of the command window in a MATLAB Automation server:

```
Dim Matlab As Object
```

```
Matlab = CreateObject("matlab.application")  
Matlab.MinimizeCommandWindow
```

```
'Now return the server window to its former state on  
'the desktop and make it the currently active window.
```

```
Matlab.MaximizeCommandWindow
```

See Also MinimizeCommandWindow

Purpose Control maximum number of computational threads

Note `maxNumCompThreads` will be removed in a future version. You can set the `-singleCompThread` option when starting MATLAB to limit MATLAB to a single computational thread. By default, MATLAB makes use of the multithreading capabilities of the computer on which it is running.

Syntax

```
N = maxNumCompThreads
LASTN = maxNumCompThreads(N)
LASTN = maxNumCompThreads('automatic')
```

Description

`N = maxNumCompThreads` returns the current maximum number of computational threads `N`.

`LASTN = maxNumCompThreads(N)` sets the maximum number of computational threads to `N`, and returns the previous maximum number of computational threads, `LASTN`.

`LASTN = maxNumCompThreads('automatic')` sets the maximum number of computational threads using what the MATLAB software determines to be the most desirable. It additionally returns the previous maximum number of computational threads, `LASTN`.

Currently, the maximum number of computational threads is equal to the number of computational cores on your machine.

Note Setting the maximum number of computational threads using `maxNumCompThreads` does not propagate to your next MATLAB session.

mean

Purpose Average or mean value of array

Syntax

```
M = mean(A)
M = mean(A,dim)
M = mean( ___, type)
```

Description `M = mean(A)` returns the mean value along the first array dimension of `A` whose size does not equal 1.

- If `A` is a vector, then `mean(A)` returns the mean of the elements.
- If `A` is a nonempty, nonvector matrix, then `mean(A)` treats the columns of `A` as vectors and returns a row vector whose elements are the mean of each column.
- If `A` is an empty 0-by-0 matrix, then `mean(A)` returns NaN.
- If `A` is a multidimensional array, then `mean(A)` treats the values along the first array dimension whose size does not equal 1 as vectors and returns an array of row vectors. The size of this dimension becomes 1 while the sizes of all other dimensions remain the same.

`M = mean(A,dim)` returns the mean along dimension `dim`. For example, if `A` is a matrix, then `mean(A,2)` is a column vector containing the mean of each row.

`M = mean(___, type)` returns the mean in the class specified by `type`, using any of the input arguments in the previous syntaxes. `type` can be 'double', 'native', or 'default'.

Input Arguments

A - Input array
vector | matrix | multidimensional array

Input array, specified as a vector, matrix, or multidimensional array.

If `A` contains NaN, then `M` returns NaN.

Data Types

double | single | int8 | int16 | int32 | int64 | uint8 |
uint16 | uint32 | uint64

dim - Dimension to operate along

positive integer scalar

Dimension to operate along, specified as a positive integer scalar. If no value is specified, the default is the first array dimension whose size does not equal 1.

Dimension dim indicates the dimension whose length reduces to 1. The $size(M,dim)$ is 1, while the sizes of all other dimensions remain the same.

Consider a two-dimensional input array, A .

- If $dim = 1$, then $mean(A,1)$ returns a row vector containing the mean of the elements in each column.
- If $dim = 2$, then $mean(A,2)$ returns a column vector containing the mean of the elements in each row.

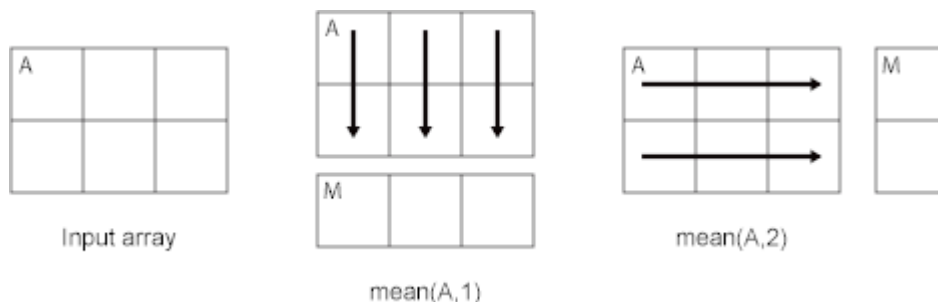

`mean` returns A if dim is greater than $ndims(A)$.

Data Types

double | single | int8 | int16 | int32 | int64 | uint8 |
uint16 | uint32 | uint64

type - Output class

mean

'default' (default) | 'double' | 'native'

Output class, specified as 'default', 'double', or 'native', and which defines the data type of the output, M.

| type | Output data type |
|-----------|--|
| 'default' | double, unless the input data type is single. In which case, the output data type is single. |
| 'double' | double |
| 'native' | same data type as the input array, A |

Examples

Mean of Matrix Columns

Define a 4-by-3 matrix.

```
A = [0 1 1; 2 3 2; 1 3 2; 4 2 2]
```

```
A =
```

```
    0     1     1
    2     3     2
    1     3     2
    4     2     2
```

Find the mean value of each column.

```
M = mean(A)
```

```
M =
```

```
    1.7500    2.2500    1.7500
```

Mean of Matrix Rows

Define a 2-by-3 matrix.

```
A = [0 1 1; 2 3 2]
```

```
A =
```

```
    0    1    1
    2    3    2
```

Find the mean value of each row.

```
M = mean(A,2)
```

```
M =
```

```
    0.6667
    2.3333
```

Mean of 3-D array

Create a 1-by-3-by-4 array of integers between 1 and 10.

```
A = gallery('integerdata',10,[1,3,4],1)
```

```
A(:,:,1) =
```

```
    10     8    10
```

```
A(:,:,2) =
```

```
     6     9     5
```

```
A(:,:,3) =
```

```
     9     6     1
```

```
A(:,:,4) =
```

```
     4     9     5
```

mean

Find the mean values of this 3-D array along the second dimension.

```
M = mean(A)
```

```
M(:, :, 1) =
```

```
    9.3333
```

```
M(:, :, 2) =
```

```
    6.6667
```

```
M(:, :, 3) =
```

```
    5.3333
```

```
M(:, :, 4) =
```

```
    6
```

This operation produces a 1-by-1-by-4 array by computing the mean of the three values along the second dimension. The size of the second dimension is reduced to 1.

Compute the mean along the first dimension of A.

```
M = mean(A, 1);
```

```
isequal(A,M)
```

```
ans =
```

```
    1
```

This operation returns the same array as A because the size of the first dimension is 1.

Mean of 8-bit Integer Array

Define a 1-by-4 vector of 8-bit integers.

```
A = int8(1:4)
```

```
A =
```

```
     1     2     3     4
```

Compute the mean value.

```
M = mean(A),  
class(M)
```

```
M =
```

```
     2.5000
```

```
ans =
```

```
double
```

M is the mean value returned as `double`. This operation returns the same result as `M = mean(A, 'default')`.

Specify type as `'native'` to return the mean value as an 8-bit integer.

```
M = mean(A, 'native'),  
class(M)
```

```
M =
```

```
     3
```

```
ans =
```

mean

`int8`

See Also

`corrcoef` | `cov` | `max` | `median` | `min` | `mode` | `std` | `var`

| | |
|------------------------|--|
| Purpose | Median value of array |
| Syntax | <code>M = median(A)</code>
<code>M = median(A,dim)</code> |
| Description | <p><code>M = median(A)</code> returns the median value of A.</p> <ul style="list-style-type: none">• If A is a vector, then <code>median(A)</code> returns the median value of A.• If A is a nonempty matrix, then <code>median(A)</code> treats the columns of A as vectors and returns a row vector of median values.• If A is an empty 0-by-0 matrix, <code>median(A)</code> returns NaN.• If A is a multidimensional array, then <code>median(A)</code> acts along the first nonsingleton dimension and returns an array of median values. The size of this dimension reduces to 1 while the sizes of all other dimensions remain the same. <p><code>median</code> computes natively in the numeric class of A, such that <code>class(M) = class(A)</code>.</p> <p><code>M = median(A,dim)</code> returns the median of elements along dimension <code>dim</code>. For example, if A is a matrix, then <code>median(A,2)</code> is a column vector containing the median value of each row.</p> |
| Input Arguments | <p>A - Input array
vector matrix multidimensional array</p> <p>Input array, specified as a vector, matrix, or multidimensional array.</p> <p>If A contains NaN, then M returns NaN.</p> <p>Data Types
double single int8 int16 int32 int64 uint8 uint16 uint32 uint64</p> <p>dim - Dimension to operate along
positive integer scalar</p> |

median

Dimension to operate along, specified as a positive integer scalar. If no value is specified, the default is the first array dimension whose size does not equal 1.

Dimension `dim` indicates the dimension whose length reduces to 1. The `size(M,dim)` is 1, while the sizes of all other dimensions remain the same.

Consider a two-dimensional input array, `A`.

- If `dim = 1`, then `median(A,1)` returns a row vector containing the median of the elements in each column.
- If `dim = 2`, then `median(A,2)` returns a column vector containing the median of the elements in each row.

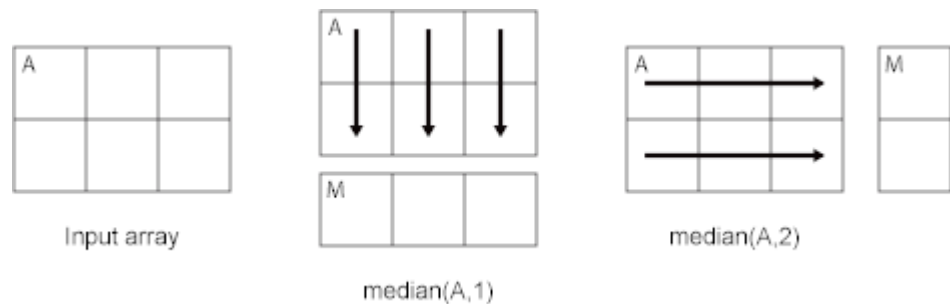

`median` returns `A` if `dim` is greater than `ndims(A)`.

Data Types

double | single | int8 | int16 | int32 | int64 | uint8 | uint16 | uint32 | uint64

Definitions

First Nonsingleton Dimension

The first nonsingleton dimension is the first dimension of an array whose size is not equal to 1.

For example:

- If `X` is a 1-by-`n` row vector, then the second dimension is the first nonsingleton dimension of `X`.

- If X is a 1-by-0-by- n empty array, then the second dimension is the first nonsingleton dimension of X .
- If X is a 1-by-1-by-3 array, then the third dimension is the first nonsingleton dimension of X .

Examples

Median of Matrix Columns

Define a 4-by-3 matrix.

```
A = [0 1 1; 2 3 2; 1 3 2; 4 2 2]
```

```
A =
```

```

0     1     1
2     3     2
1     3     2
4     2     2
```

Find the median value of each column.

```
M = median(A)
```

```
M =
```

```
1.5000    2.5000    2.0000
```

For each column, the median value is the mean of the middle two numbers in sorted order.

Median of Matrix Rows

Define a 2-by-3 matrix.

```
A = [0 1 1; 2 3 2]
```

```
A =
```

```

0     1     1
2     3     2
```

median

```
2     3     2
```

Find the median value of each row.

```
M = median(A,2)
```

```
M =
```

```
1  
2
```

For each row, the median value is the middle number in sorted order.

Median of 3-D Array

Create a 1-by-3-by-4 array of integers between 1 and 10.

```
A = gallery('integerdata',10,[1,3,4],1)
```

```
A(:,:,1) =
```

```
10     8     10
```

```
A(:,:,2) =
```

```
6     9     5
```

```
A(:,:,3) =
```

```
9     6     1
```

```
A(:,:,4) =
```

```
4     9     5
```

Find the median values of this 3-D array along the second dimension.

```
M = median(A)
```

```
M(:,:,1) =
```

```
10
```

```
M(:,:,2) =
```

```
6
```

```
M(:,:,3) =
```

```
6
```

```
M(:,:,4) =
```

```
5
```

This operation produces a 1-by-1-by-4 array by computing the median of the three values along the second dimension. The size of the second dimension is reduced to 1.

Compute the median along the first dimension of A.

```
M = median(A,1);
```

```
isequal(A,M)
```

```
ans =
```

```
1
```

This returns the same array as A because the size of the first dimension is 1.

Median of 8-bit Integer Array

Define a 1-by-4 vector of 8-bit integers.

```
A = int8(1:4)
```

```
A =
```

```
    1    2    3    4
```

Compute the median value.

```
M = median(A),  
class(M)
```

```
M =
```

```
    3
```

```
ans =
```

```
int8
```

M is the mean of the middle two numbers in sorted order returned as an 8-bit integer.

See Also

[corrcoef](#) | [cov](#) | [max](#) | [mean](#) | [min](#) | [mode](#) | [std](#) | [var](#)

Purpose Create memory map to a file

Syntax
`m = memmapfile(filename)`
`m = memmapfile(filename,Name,Value)`

Description `m = memmapfile(filename)` maps an existing file, `filename`, to memory and returns the memory map, `m`.

Memory-mapping is a mechanism that maps a portion of a file, or an entire file, on disk to a range of memory addresses within the MATLAB address space. Then, MATLAB can access files on disk in the same way it accesses dynamic memory, accelerating file reading and writing. Memory-mapping allows you to work with data in a file as if it were a MATLAB array.

`m = memmapfile(filename,Name,Value)` specifies the properties of `m` using one or more name-value pair arguments. For example, you can specify the format of the data in the file.

Input Arguments

filename - Name of file to map

string

Name of the file to map including the file extension, specified as a string. The `filename` argument cannot include any wildcard characters (for example, `*` or `?`).

Example: `'myFile.dat'`

Data Types

char

Name-Value Pair Arguments

Specify optional comma-separated pairs of `Name,Value` arguments. `Name` is the argument name and `Value` is the corresponding value. `Name` must appear inside single quotes (`' '`). You can specify several name and value pair arguments in any order as `Name1,Value1,...,NameN,ValueN`.

memmapfile

Example: `m = memmapfile('myFile.dat', 'Format', 'int32', 'Offset', 255)`
maps int32 data in the file, myFile.dat, to memory starting from the 256th byte.

'Writable' - Type of access allowed to mapped region

false (default) | true

Type of access allowed to the mapped region, specified as the comma-separated pair consisting of 'Writable' and either true or false. If the Writable property is set to false, the mapped region is read-only. If true, then write access is allowed.

Example: 'Writeable', true

Data Types

logical

'Offset' - Number of bytes from start of file to start of mapped region

0 (default) | nonnegative integer

Number of bytes from the start of the file to the start of the mapped region, specified as the comma-separated pair consisting of 'Offset' and a nonnegative integer. This value is zero-based. That is, an Offset value of 0 represents the start of the file.

Example: 'Offset', 1024

Data Types

double

'Format' - Format of mapped region

'uint8' (default) | string | n-by-3 cell array

Format of the mapped region contents, specified as the comma-separated pair consisting of 'Format' and a single string or an n-by-3 cell array.

- If the file region you are mapping contains data of only one type, specify the Format value as a string identifying that type.

Example: 'int16'

- To specify an array shape to apply to the data read or written to the mapped file, and a field name to reference this array, specify the `Format` value as a 1-by-3 cell array. The first cell contains a string identifying the data type to apply to the mapped region. The second cell contains the array dimensions to apply to the region. The third cell contains a string specifying the field name to use in the `Data` structure array of the memory map.

Example: `{'uint64',[30 4 10],'x'}`

- If the region you are mapping is composed of segments of varying data types or array shapes, you can specify an individual format for each segment using an n-by-3 cell array, where n is the number of segments.

Example: `{'uint64',[30 4 10],'x'; 'uint32',[30 4 6],'y'}`

You can use any of the following data types when you specify a `Format` value:

- `'int8'`
- `'int16'`
- `'int32'`
- `'int64'`
- `'uint8'`
- `'uint16'`
- `'uint32'`
- `'uint64'`
- `'single'`
- `'double'`

Data Types

`char` | `cell`

'Repeat' - Number of times to apply `Format` parameter

`Inf` (default) | positive integer

memmapfile

Number of times to apply the `Format` parameter to the mapped region of the file, specified as the comma-separated pair consisting of `'Repeat'` and a positive integer. If the value of `Repeat` is `Inf`, then `memmapfile` applies the `Format` parameter until the end of the file.

Example: `'Repeat',2000`

Data Types

double

Output Arguments

m - Memory map

`memmapfile` object

Memory map, returned as a `memmapfile` object with the following properties.

| Property | Description |
|----------|--|
| Filename | Path and name of the mapped file |
| Writable | Type of access allowed to the mapped region |
| Offset | Number of bytes from the start of the file to the start of the mapped region |
| Format | Format of the contents of the mapped region, including data type, array size, and field name by which to access the data |
| Repeat | Number of times to apply the pattern specified by the <code>Format</code> property to the mapped region of the file |
| Data | Memory-mapped data from the file. <code>Data</code> can be a numeric array or a structure array with field names specified in the <code>Format</code> property |

The values for any property (except for `Data`) are set at the time you call `memmapfile`, using name-value pair arguments.

Access any property of `m` with dot notation similar to accessing fields of a structure array. For example, to access the memory-mapped data in the `Data` property, do one of the following:

- If `Data` is a numeric array, call `m.Data`.
- If `Data` is a scalar (1-by-1) structure array, call `m.Data.fieldname`, where `fieldname` is the name of a field.
- If `Data` is a nonscalar structure array, call `m.Data(index).fieldname` where `index` is the index for the element in the structure array, and `fieldname` is the name of a field. For example, to access the file data in the `temperature` field of the first element of `Data`, call `m.Data(1).temperature`.

After you create a memory map, `m`, you can change the value of any of its properties, except for `Data`. To assign a new value, use dot notation. For example, to set a new `Offset` value for `m`, type:

```
m.Offset = 2048;
```

Examples

Map Entire File of uint8 Data

At the command prompt, create a sample file in your current folder called `records.dat`, containing 10 `uint8` values.

```
myData = uint8(1:10)';  
  
fileID = fopen('records.dat','w');  
fwrite(fileID, myData, 'uint8');  
fclose(fileID);
```

Create a map for `records.dat`. When using `memmapfile`, the default data format is `uint8` so the file name is the only required input argument in this case.

```
m = memmapfile('records.dat')
```

```
m =
```

memmapfile

```
Filename: 'd:\matlab\records.dat'  
Writable: false  
Offset: 0  
Format: 'uint8'  
Repeat: Inf  
Data: 10x1 uint8 array
```

MATLAB maps the entire `records.dat` file to memory, setting all properties of the memory map to their default values. The memory map is assigned to the variable, `m`. In this example, the command maps the entire file as a sequence of unsigned 8-bit integers and gives the caller read-only access to its contents.

View the mapped data by accessing the `Data` property of `m`.

`m.Data`

`ans =`

```
1  
2  
3  
4  
5  
6  
7  
8  
9  
10
```

Map Entire File of Double-Precision Data

Create a memory map for double-precision data. The syntax is similar when specifying other data types.

At the command prompt, create a sample file in your current folder called `records.dat`, containing 10 double values.

```
myData = (1:10)';
```

```
fileID = fopen('records.dat','w');  
fwrite(fileID,myData,'double');  
fclose(fileID);
```

Create a memory map for `records.dat`, and set the `Format` property for the output to `'double'`.

```
m = memmapfile('records.dat','Format','double')
```

```
m =
```

```
    Filename: 'd:\matlab\records.dat'  
    Writable: false  
    Offset: 0  
    Format: 'double'  
    Repeat: Inf  
    Data: 10x1 double array
```

The `Data` property contains the 10 double-precision values in `records.dat`.

Map and Change Part of a File

Create a memory map for a large array of `int32` data. Specify write access, and nondefault `Format` and `Offset` values.

At the command prompt, create a sample file in your current folder called `records.dat`, containing 10,000 `int32` values.

```
myData = int32([1:10000]);
```

```
fileID = fopen('records.dat','w');  
fwrite(fileID,myData,'int32');  
fclose(fileID);
```

Create a memory map for `records.dat`, and set the `Format` property for the output to `int32`. Also, set the `Offset` property to disregard the first 9000 bytes in the file, and the `Writable` property to permit write access.

memmapfile

```
m = memmapfile('records.dat',...
               'Offset',9000,...
               'Format','int32',...
               'Writable',true);
```

An `Offset` value of 9000 indicates that the first 9000 bytes of `records.dat` are not mapped.

Type the name of the memory map to see the current settings for all properties.

```
m

m =
  Filename: 'd:\matlab\records.dat'
  Writable: true
  Offset: 9000
  Format: 'int32'
  Repeat: Inf
  Data: 7750x1 int32 array
```

The `Format` property indicates that any read or write operation made via the memory map reads and writes the file contents as a sequence of signed 32-bit integers. The `Data` property contains only 7750 elements because the first 9000 bytes of `records.dat`, representing the first 2250 values in the file, are not mapped.

View the first five elements of the mapped data by accessing the `Data` property of `m`.

```
m.Data(1:5)
```

```
ans =

    2251
    2252
    2253
    2254
```

2255

Map Region of File to Specific Array Shape

Create a memory map for a region of a file containing 100 double-precision values.

At the command prompt, create a sample file in your current folder called `mybinary.bin`, containing 100 double-precision values.

```
randData = gallery('uniformdata',[100,1],0,'double');

fileID = fopen('mybinary.bin','w');
fwrite(fileID,randData,'double');
fclose(fileID);
```

Map the first 75 values in `mybinary.bin` to a 5-by-5-by-3 array of double-precision values that can be referenced in the structure of the memory map using the field name `x`. Specify these parameters with the `Format` name-value pair argument.

```
m = memmapfile('mybinary.bin',...
              'Format',{'double',[5 5 3],'x'})
```

```
m =
```

```
Filename: 'd:\matlab\mybinary.bin'
Writable: false
Offset: 0
Format: {'double' [5 5 3] 'x'}
Repeat: Inf
Data: 1x1 struct array with fields:
      x
```

The `Data` property is a structure array that contains the mapped values in the field, `x`.

Assign the mapped data to a variable, `A`. Because the `Data` property is a structure array, you must index into the field, `x`, to access the data.

```
A = m.Data.x;
```

View information about A.

```
whos A
```

| Name | Size | Bytes | Class | Attributes |
|------|-------|-------|--------|------------|
| A | 5x5x3 | 600 | double | |

Map Segments of File to Multiple Arrays

Map segments of a file with different array shapes and data types to memory.

At the command prompt, create a sample file in your current folder called `mybinary.bin`. Write `uint16` data and double-precision data representing sample pressure, temperature, and volume values into the file. In this case, each of the `uint16` arrays are 50-by-1 and the double-precision arrays are 5-by-10. `k` is a sample scaling factor.

```
k = 8.21;
[pres1,temp1] = gallery('integerdata',[1,300],[50,1],0,'uint16');
vol1 = double(reshape(k*temp1./pres1,5,10));
[pres2,temp2] = gallery('integerdata',[5,500],[50,1],5,'uint16');
vol2 = double(reshape(k*temp2./pres2,5,10));

fileID = fopen('mybinary.bin','w');
fwrite(fileID,pres1,'uint16');
fwrite(fileID,temp1,'uint16');
fwrite(fileID,vol1,'double');
fwrite(fileID,pres2,'uint16');
fwrite(fileID,temp2,'uint16');
fwrite(fileID,vol2,'double');
fclose(fileID);
```

Map the file to arrays accessible by unique names. Define a field, `pressure`, containing a 50-by-1 array of `uint16` values, followed by a field, `temperature`, containing 50-by-1 `uint16` values. Define a field,

`volume`, containing a 5-by-10 array of double-precision values. Use a cell array to define the format of the mapped region and repeat the pattern twice.

```
m = memmapfile('mybinary.bin',...
'Format',{ 'uint16',[50 1], 'pressure';...
'uint16',[50,1], 'temperature';...
'double',[5,10], 'volume'}, 'Repeat',2)

m =

    Filename: 'd:\matlab\mybinary.bin'
    Writable: false
    Offset: 0
    Format: { 'uint16' [50 1] 'pressure'
             'uint16' [50 1] 'temperature'
             'double' [5 10] 'volume' }
    Repeat: 2
    Data: 2x1 struct array with fields:
        pressure
        temperature
        volume
```

The `Data` property of the memory map, `m`, is a 2-by-1 structure array because the `Format` is applied twice.

Copy the `Data` property to a variable, `A`. Then, view the last block of double data, which you can access using the field name, `volume`.

```
A = m.Data;
myVolume = A(2).volume
```

```
myVolume =
```

```
     2     13     32     5     5     16     4     22     3     8
     2     9     53     38     13     19     23     85     2    120
    29     10     6     1     2     5     6     58     20     11
     7     15     4     1     5     18     1     4     14     8
```

memmapfile

9 8 4 2 0 9 8 6 3 3

Tips

- You can map only an existing file. You cannot create a new file and map that file to memory in one operation. Use the MATLAB file I/O functions to create the file before attempting to map it to memory.
- After `memmapfile` locates the file, MATLAB stores the file's absolute pathname internally, and then uses this stored path to locate the file from that point on. As a result, you can work in other directories outside your current work directory and retain access to the mapped file.
- `memmapfile` does not expand or append to a mapped file. Use instead standard file I/O functions like `fopen` and `fwrite`.

Algorithms

The actual mapping of a file to the MATLAB address space does not take place when you construct a `memmapfile` object. A memory map, based on the information currently stored in the mapped object, is generated the first time you reference or modify the `Data` property for that object.

Related Examples

- “Map File to Memory”

Concepts

- “Overview of Memory-Mapping”

- Purpose** Display memory information
- Syntax**
- ```
memory
userview = memory
[userview systemview] = memory
```
- Limitations**
- The memory function is available only on Microsoft Windows systems. Results are dependant on your computer hardware and the load on your computer.
- Description**
- memory displays information showing how much memory is available and how much the MATLAB software is currently using. The information displayed at your computer screen includes the following items, each of which is described in a section below:
- “Maximum Possible Array” on page 1-4252
  - “Memory Available for All Arrays” on page 1-4253
  - “Memory Used By MATLAB” on page 1-4254
  - “Total Physical Memory (RAM)” on page 1-4254
- userview = memory returns user-focused information on memory use in structure userview. The information returned in userview includes the following items, each of which is described in a section below:
- “Maximum Possible Array” on page 1-4252
  - “Memory Available for All Arrays” on page 1-4253
  - “Memory Used By MATLAB” on page 1-4254
- [userview systemview] = memory returns both user- and system-focused information on memory use in structures userview and systemview, respectively. The userview structure is described in the command syntax above. The information returned in systemview includes the following items, each of which is described in a section below:
- “Virtual Address Space” on page 1-4255

- “System Memory” on page 1-4255
- “Physical Memory” on page 1-4256

## Output Arguments

Each of the sections below describes a value that is displayed or returned by the `memory` function.

### Maximum Possible Array

Maximum Possible Array is the size of the largest contiguous free memory block. As such, it is an upper bound on the largest single array MATLAB can create at this time.

MATLAB derives this number from the smaller of the following two values:

- The largest contiguous memory block found in the MATLAB virtual address space
- The total available system memory

To see how many array elements this number represents, divide by the number of bytes in the array class. For example, for a `double` array, divide by 8. The actual number of elements MATLAB can create is always fewer than this number.

When you enter the `memory` command without assigning its output, MATLAB displays this information as a string. When you do assign the output, MATLAB returns the information in a structure field. See the table below.

Command	Returned in
<code>memory</code>	String labelled Maximum possible array:
<code>user = memory</code>	Structure field <code>user.MaxPossibleArrayBytes</code>

All values are double-precision and in units of bytes.

### Footnotes

When you enter the `memory` command without specifying any outputs, MATLAB may also display one of the following footnotes. 32-bit systems

show either the first or second footnote; 64-bit systems show only the second footnote:

Limited by contiguous virtual address space available.

There is sufficient system memory to allow mapping of all virtual addresses in the largest available block of the MATLAB process. The maximum amount of total MATLAB virtual address space is either 2 GB or 3 GB, depending on whether the /3GB switch is in effect or not.

Limited by System Memory (physical + swap file) available.

There is insufficient system memory to allow mapping of all virtual addresses in the largest available block of the MATLAB process.

## Memory Available for All Arrays

Memory Available for All Arrays is the total amount of memory available to hold data. The amount of memory available is guaranteed to be at least as large as this field.

MATLAB derives this number from the smaller of the following two values:

- The total available MATLAB virtual address space
- The total available system memory

When you enter the `memory` command without assigning its output, MATLAB displays this information as a string. When you do assign the output, MATLAB returns the information in a structure field. See the table below.

Command	Returned in
<code>memory</code>	String labelled Memory available for all arrays:
<code>user = memory</code>	Structure field <code>user.MemAvailableAllArrays</code>

## Footnotes

When you enter the `memory` command without specifying any outputs, MATLAB may also display one of the following footnotes. 32-bit systems

show either the first or second footnote; 64-bit systems show only the latter footnote:

Limited by virtual address space available.

There is sufficient system memory to allow mapping of all available virtual addresses in the MATLAB process virtual address space to system memory. The maximum amount of total MATLAB virtual address space is either 2 GB or 3 GB, depending on whether the /3GB switch is in effect or not.

Limited by System Memory (physical + swap file) available.

There is insufficient system memory to allow mapping of all available virtual addresses in the MATLAB process.

## Memory Used By MATLAB

Memory Used By MATLAB is the total amount of system memory reserved for the MATLAB process. It is the sum of the physical memory and potential swap file usage.

When you enter the `memory` command without assigning its output, MATLAB displays this information as a string. When you do assign the output, MATLAB returns the information in a structure field. See the table below.

Command	Returned in
<code>memory</code>	String labelled Memory used by MATLAB:
<code>user = memory</code>	Structure field <code>user.MemUsedMATLAB</code>

## Total Physical Memory (RAM)

Physical Memory (RAM) is the total physical memory (or RAM) in the computer.

When you enter the `memory` command without assigning its output, MATLAB displays this information as a string. See the table below.



Command	Returned in
memory	String labelled Physical Memory (RAM):

### Virtual Address Space

Virtual Address Space is the amount of available and total virtual memory for the MATLAB process. MATLAB returns the information in two fields of the return structure: Available and Total.

Command	Return Value	Returned in Structure Field
[user,sys] = memory	Available memory	sys.VirtualAddressSpace.Available
	Total memory	sys.VirtualAddressSpace.Total

You can monitor the difference:

```
VirtualAddressSpace.Total - VirtualAddressSpace.Available
```

as the Virtual Bytes counter in the WindowsPerformance program. (e.g., Windows XP Control Panel/Administrative Tool/Performance program).

### System Memory

System Memory is the amount of available system memory on your computer system. This number includes the amount of available physical memory and the amount of available swap file space on the computer running MATLAB. MATLAB returns the information in the SystemMemory field of the return structure.

Command	Return Value	Returned in Structure Field
[user,sys] = memory	Available memory	sys.SystemMemory

This is the same as the difference:

```
limit - total (in bytes)
```

# memory

---

found in the Windows Task Manager: Performance/Commit Charge.

## Physical Memory

Physical Memory is the available and total amounts of physical memory (RAM) on the computer running MATLAB. MATLAB returns the information in two fields of the return structure: `Available` and `Total`.

Command	Value	Returned in Structure Field
[user,sys] = memory	Available memory	sys.PhysicalMemory.Available
	Total memory	sys.PhysicalMemory.Total

Available physical memory is the same as:

Available (in bytes)

found in the Windows Task Manager: Performance/Physical Memory

The total physical memory is the same as

Total (in bytes)

found in the Windows Task Manager: Performance/Physical Memory

You can use the amount of available physical memory as a measure of how much data you can access quickly.

## Tips

### Details on Memory Used By MATLAB

MATLAB computes the value for Memory Used By MATLAB by walking the MATLAB process memory structures and summing all the sections that have physical storage allocated in memory or in the paging file on disk.

Using the Windows Task Manager, you have for the MATLAB.exe image:

Mem Usage < MemUsedMATLAB < Mem Usage + VM Size (in bytes)

where both of the following are true:

- **Mem Usage** is the working set size in kilobytes.
- **VM Size** is the page file usage, or private bytes, in kilobytes.

The working set size is the portion of the MATLAB virtual address space that is *currently* resident in RAM and can be referenced without a memory page fault. The page file usage gives the portion of the MATLAB virtual address space that requires a backup that doesn't already exist. Another name for page file usage is *private bytes*. It includes all MATLAB variables and workspaces. Since some of the pages in the page file may also be part of the working set, this sum is an overestimate of MemUseMATLAB. Note that there are virtual pages in the MATLAB process space that already have a backup. For example, code loaded from EXEs and DLLs and memory-mapped files. If any part of those files is in memory when the memory builtin is called, that memory will be counted as part of MemUsedMATLAB.

## Reserved Addresses

Reserved addresses are addresses sets aside in the process virtual address space for some specific future use. These reserved addresses reduce the size of MemAvailableAllArrays and can reduce the size of the current or future value of MaxPossibleArrayBytes.

### Example 1 – Java Virtual Machine (JVM)

At MATLAB startup, part of the MATLAB virtual address space is reserved by the Java Virtual Machine (JVM) and cannot be used for storing MATLAB arrays.

### Example 2 – Standard Windows Heap Manager

MATLAB, by default, uses the standard Windows heap manager except for a set of small preselected allocation sizes. One characteristic of this heap manager is that its behavior depends upon whether the requested allocation is less than or greater than the fixed number of 524,280 bytes. For, example, if you create a sequence of MATLAB arrays, each less than 524,280 bytes, and then clear them all, the MemUsedMATLAB value before and after shows little change, and the MemAvailableAllArrays value is now smaller by the total space allocated.

The result is that, instead of globally freeing the extra memory, the memory becomes reserved. It can *only* be reused for arrays less than 524,280 bytes. You cannot reclaim this memory for a larger array except by restarting MATLAB.

## Examples

Display memory statistics on a 32-bit Windows system:

```
memory
```

```
Maximum possible array: 677 MB (7.101e+008 bytes) *
Memory available for all arrays: 1601 MB (1.679e+009 bytes) **
Memory used by MATLAB: 446 MB (4.681e+008 bytes)
Physical Memory (RAM): 3327 MB (3.489e+009 bytes)
```

\* Limited by contiguous virtual address space available.

\*\* Limited by virtual address space available.

Return in the structure `userview`, information on the largest array MATLAB can create at this time, how much memory is available to hold data, and the amount of memory currently being used by your MATLAB process:

```
userview = memory
```

```
userview =
 MaxPossibleArrayBytes: 710127616
 MemAvailableAllArrays: 1.6792e+009
 MemUsedMATLAB: 468127744
```

Assign the output to two structures, `user` and `sys`, to obtain the information shown here:

```
[user sys] = memory;

% --- Largest array MATLAB can create ---
user.MaxPossibleArrayBytes
ans =
 710127616
```

```
% --- Memory available for data ---
user.MemAvailableAllArrays
ans =
 1.6797e+009

% --- Memory used by MATLAB process ---
user.MemUsedMATLAB
ans =
 467603456

% --- Virtual memory for MATLAB process ---
sys.VirtualAddressSpace
ans =
 Available: 1.6797e+009
 Total: 2.1474e+009

% --- Physical memory and paging file ---
sys.SystemMemory
ans =
 Available: 4.4775e+009

% --- Computer's physical memory ---
sys.PhysicalMemory
ans =
 Available: 2.3941e+009
 Total: 3.4889e+009
```

## See Also

`clear` | `pack` | `whos` | `inmem` | `save` | `load` | `mlock` | `munlock`

## Tutorials

- “Memory Allocation”
- “Strategies for Efficient Use of Memory”
- “Resolving “Out of Memory” Errors”

# menu

---

**Purpose** Generate menu of choices for user input

**Syntax**  
`choice = menu('mtitle','opt1','opt2',..., 'optn')`  
`choice = menu('mtitle',options)`

**Description** `choice = menu('mtitle','opt1','opt2',..., 'optn')` displays the menu whose title is in the string variable 'mtitle' and whose choices are string variables 'opt1', 'opt2', and so on. The menu opens in a modal dialog box. `menu` returns the number of the selected menu item, or 0 if the user clicks the close button on the window.

`choice = menu('mtitle',options)` , where `options` is a 1-by-N cell array of strings containing the menu choices.

If the user's terminal provides a graphics capability, `menu` displays the menu items as push buttons in a figure window (Example 1). Otherwise, they will be given as a numbered list in the Command Window (Example 2).

**Tips** To call `menu` from a `uicontrol` or other `ui` object, set that object's `Interruptible` property to 'on'. For more information, see `Uicontrol Properties`.

## **Examples** **Example 1**

On a system with a display, `menu` displays choices as buttons in a dialog box:

```
choice = menu('Choose a color','Red','Blue','Green')
```

displays the following dialog box.

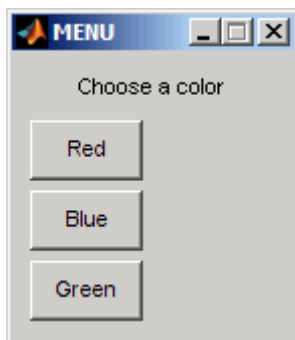

The number entered by the user in response to the prompt is returned as `choice` (i.e., `choice = 2` implies that the user selected Blue).

After input is accepted, the dialog box closes, returning the output in `choice`. You can use `choice` to control the color of a graph:

```
t = 0:.1:60;
s = sin(t);
color = ['r','b','g']
plot(t,s,color(choice))
```

## Example 2

On a system without a display, `menu` displays choices in the Command Window:

```
choice = menu('Choose a color','Red','Blue','Green')
```

displays the following text.

```
----- Choose a color -----
1) Red
2) Blue
3) Green
Select a menu number:
```

## See Also

[guide](#) | [input](#) | [uicontrol](#) | [uimenu](#)

# mergecats

---

**Purpose** Merge categories in categorical array

**Syntax**  
B = mergecats(A,oldcats)  
B = mergecats(A,oldcats,newcat)

**Description** B = mergecats(A,oldcats) merges two or more categories in A into the first category, oldcats(1). Any values in A from oldcats become oldcats(1) in B.

B = mergecats(A,oldcats,newcat) merges oldcats into a single new category, newcat. Any values in A from oldcats become newcat in B.

## Input Arguments

**A - Categorical array**  
vector | matrix | multidimensional array

Categorical array, specified as a vector, matrix, or multidimensional array.

**oldcats - Categories to merge**  
cell array of strings

Categories to merge, specified as a cell array of strings. If A is ordinal, the categories to merge must be consecutive.

**newcat - New category**  
oldcats(1) (default) | string

New category, specified as a string.

## Examples

### Merge Two Categories into One

Create a categorical array containing various colors.

```
A = categorical({'red';'blue';'pink';'red';'blue';'red'})
```

```
A =
```

```
 red
```



```
blue
pink
red
blue
red
```

A is a 6-by-1 categorical array.

Display the categories of A.

```
categories(A)
```

```
ans =
```

```
'blue'
'pink'
'red'
```

The three categories are in alphabetical order.

Merge the categories red and pink into the category red. Specify red first in oldcats to use it as the merged category.

```
oldcats = {'red','pink'};
B = mergecats(A,oldcats)
```

```
B =
```

```
red
blue
red
red
blue
red
```

mergecats replaces the value pink from A(3) with red.

Display the categories of B.

```
categories(B)
```

```
ans =
```

```
 'blue'
 'red'
```

B has two categories instead of three.

## **Merge Alphabetically Listed Categories**

Create a categorical array containing various items.

```
A = categorical({'shirt' 'pants'; 'shoes' 'shirt'; 'dress' 'belt'})
```

```
A =
```

```
 shirt pants
 shoes shirt
 dress belt
```

Display the categories of A.

```
categories(A)
```

```
ans =
```

```
 'belt'
 'dress'
 'pants'
 'shirt'
 'shoes'
```

The five categories are in alphabetical order.

Merge the categories `belt` and `shoes` into a new category called `other`.

```
B = mergocats(A,{'belt' 'shoes'},'other')
```

```
B =
```

```

shirt pants
other shirt
dress other

```

The value `other` replaces all instances of `belt` and `shoes`.

Display the categories of `B`.

```
categories(B)
```

```
ans =
```

```

'other'
'dress'
'pants'
'shirt'

```

`B` has four categories and the order is no longer alphabetical. `other` appears in place of `belt`.

### **Merge Categories of Ordinal Categorical Array**

Create an ordinal categorical array.

```
A = categorical([1 2 3 2 1],1:3,{'poor','fair','good'},'Ordinal',true)
```

```
A =
```

```

poor fair good fair poor

```

Display the categories of `A`.

```
categories(A)
```

```
ans =
```

```

'poor'
'fair'

```

# mergecats

---

```
'good'
```

Since A is ordinal, the categories have the mathematical ordering `poor < fair < good`.

Consider all `fair` or `poor` values to be `bad`. Since A is ordinal, the categories to merge must be consecutive.

```
B = mergecats(A, {'fair' 'poor'}, 'bad')
```

```
B =
```

```
 bad bad good bad bad
```

The value `bad` replaces all instances of `fair` and `poor`.

Display the categories of B.

```
categories(B)
```

```
ans =
```

```
 'bad'
 'good'
```

B has two categories with the mathematical ordering: `bad < good`.

## See Also

```
categories | addcats | removecats | iscategory | renamecats
| reordercats
```

**Purpose**

Mesh plot

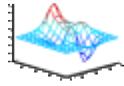
**Syntax**

```
mesh(X,Y,Z)
mesh(Z)
mesh(...,C)
mesh(...,'PropertyName',PropertyValue,...)
mesh(axes_handles,...)
h = mesh(...)
```

**Description**

`mesh(X,Y,Z)` draws a wireframe mesh with color determined by `Z`, so color is proportional to surface height. If `X` and `Y` are vectors, `length(X) = n` and `length(Y) = m`, where `[m,n] = size(Z)`. In this case,  $(X(j), Y(i), Z(i,j))$  are the intersections of the wireframe grid lines; `X` and `Y` correspond to the columns and rows of `Z`, respectively. If `X` and `Y` are matrices,  $(X(i,j), Y(i,j), Z(i,j))$  are the intersections of the wireframe grid lines.

`mesh(Z)` draws a wireframe mesh using `X = 1:n` and `Y = 1:m`, where `[m,n] = size(Z)`. The height, `Z`, is a single-valued function defined over a rectangular grid. Color is proportional to surface height.

`mesh(...,C)` draws a wireframe mesh with color determined by matrix `C`. MATLAB performs a linear transformation on the data in `C` to obtain colors from the current colormap. If `X`, `Y`, and `Z` are matrices, they must be the same size as `C`.

`mesh(...,'PropertyName',PropertyValue,...)` sets the value of the specified surface property. Multiple property values can be set with a single statement.

`mesh(axes_handles,...)` plots into the axes with handle `axes_handle` instead of the current axes (`gca`).

`h = mesh(...)` returns a handle to a Surfaceplot graphics object.

## Tips

mesh does not accept complex inputs.

A mesh is drawn as a `Surfaceplot` graphics object with the viewpoint specified by `view(3)`. The face color is the same as the background color (to simulate a wireframe with hidden-surface elimination), or none when drawing a standard see-through wireframe. The current colormap determines the edge color. The `hidden` command controls the simulation of hidden-surface elimination in the mesh, and the `shading` command controls the shading model.

## Examples

### Create Mesh Plot of Sinc Function

Create a mesh plot of the sinc function,  $z = \sin(r)/r$ .

```
[X,Y] = meshgrid(-8:.5:8);
R = sqrt(X.^2 + Y.^2) + eps;
Z = sin(R)./R;
```

```
figure
mesh(Z);
```

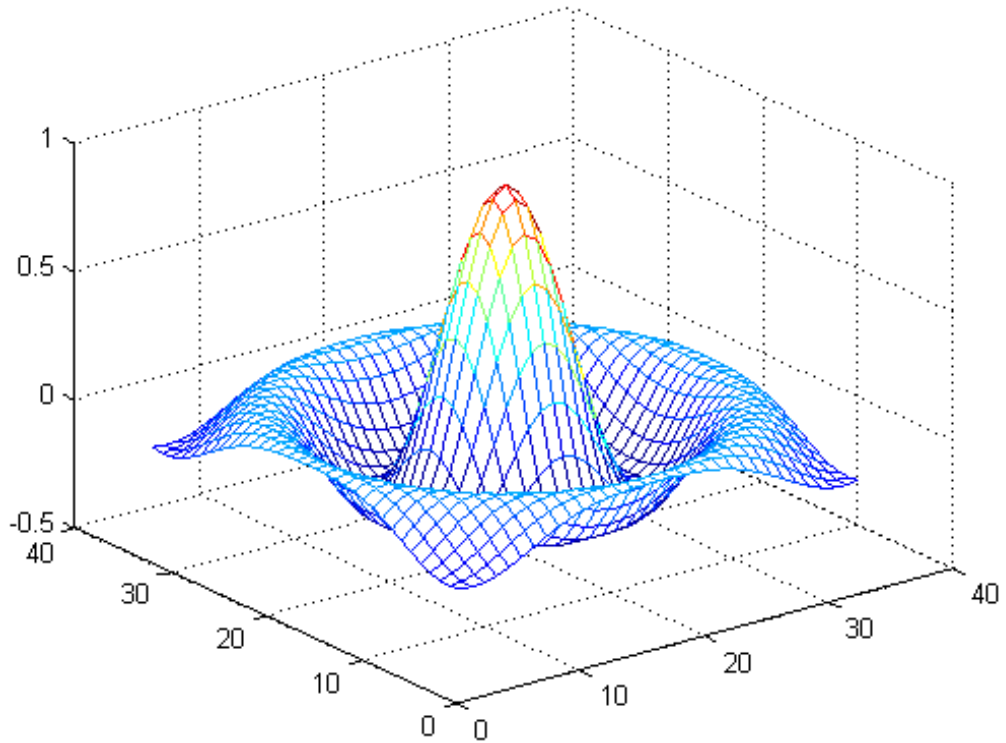

### Specify Color for Mesh Plot

Specify a color matrix for a mesh plot.

```
[X,Y] = meshgrid(-8:.5:8);
R = sqrt(X.^2 + Y.^2) + eps;
Z = sin(R)./R;
C = gradient(Z);
```

```
figure
```

# mesh

---

`mesh(X,Y,Z,C)`

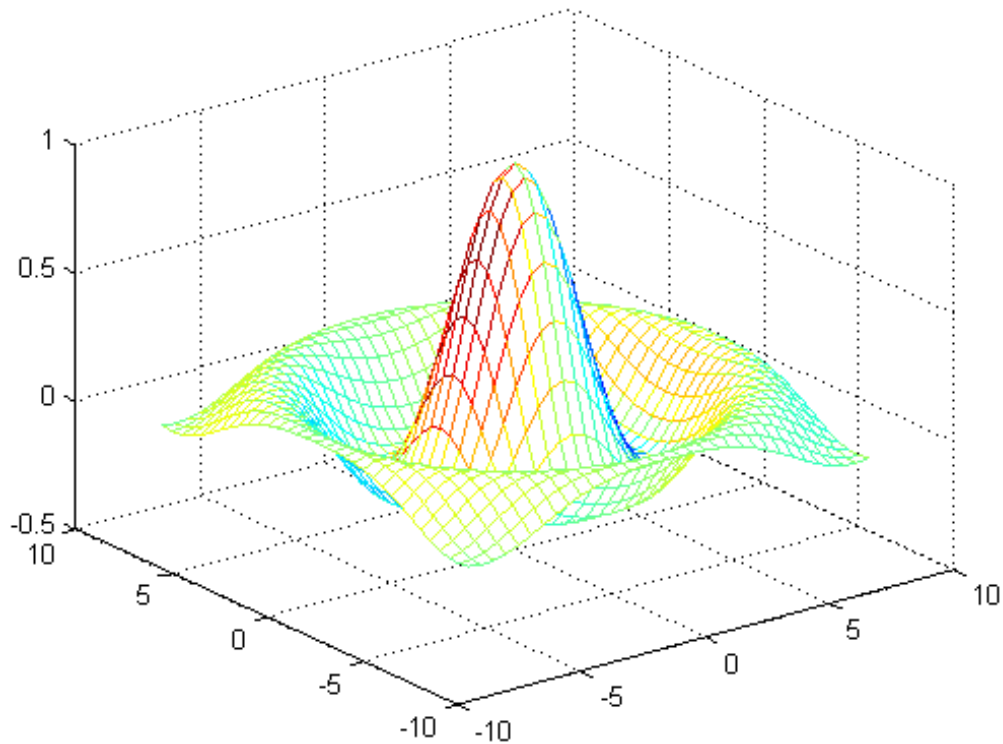

## Change Lighting and Line Width for Mesh Plot

Change the lighting and the line width for a mesh plot using Name,Value pair arguments.

```
[X,Y] = meshgrid(-8:.5:8);
R = sqrt(X.^2 + Y.^2) + eps;
Z = sin(R)./R;
```



```
C = del2(Z);

figure
mesh(X,Y,Z,C,'FaceLighting','gouraud','LineWidth',0.3)
```

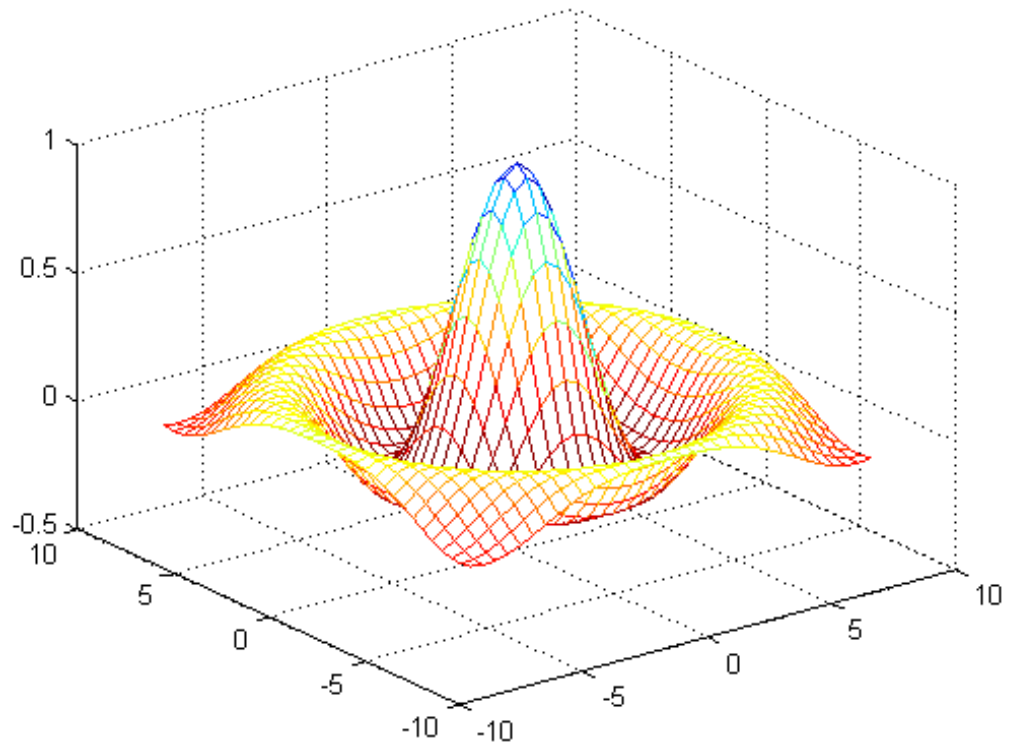
**See Also**

[meshc](#) | [meshz](#) | [hidden](#) | [griddata](#) | [scatteredInterpolant](#) | [meshgrid](#) | [surface](#) | [surf](#) | [waterfall](#) | [axis](#) | [colormap](#) | [hold](#) | [shading](#) | [view](#)

# mesh

---

## **How To**

- “Representing Data as a Surface”

**Purpose** Plot a contour graph under mesh graph

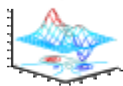

**Syntax**

```
meshc(X,Y,Z)
meshc(Z)
meshc(...,C)
meshc(axes_handles,...)
h = meshc(...)
```

**Description** `meshc(X,Y,Z)` draws a wireframe mesh and a contour plot under it with color determined by `Z`, so color is proportional to surface height. If `X` and `Y` are vectors, `length(X) = n` and `length(Y) = m`, where `[m,n] = size(Z)`. In this case,  $(X(j), Y(i), Z(i, j))$  are the intersections of the wireframe grid lines; `X` and `Y` correspond to the columns and rows of `Z`, respectively. If `X` and `Y` are matrices,  $(X(i, j), Y(i, j), Z(i, j))$  are the intersections of the wireframe grid lines.

`meshc(Z)` draws a contour plot under wireframe mesh using `X = 1:n` and `Y = 1:m`, where `[m,n] = size(Z)`. The height, `Z`, is a single-valued function defined over a rectangular grid. Color is proportional to surface height.

`meshc(...,C)` draws a `meshc` graph with color determined by matrix `C`. MATLAB performs a linear transformation on the data in `C` to obtain colors from the current colormap. If `X`, `Y`, and `Z` are matrices, they must be the same size as `C`.

`meshc(axes_handles,...)` plots into the axes with handle `axes_handle` instead of the current axes (`gca`).

`h = meshc(...)` returns a handle to a `Surfaceplot` graphics object.

**Tips** `meshc` does not accept complex inputs.

A mesh is drawn as a `Surfaceplot` graphics object with the viewpoint specified by `view(3)`. The face color is the same as the background

color (to simulate a wireframe with hidden-surface elimination), or none when drawing a standard see-through wireframe. The current colormap determines the edge color. The hidden command controls the simulation of hidden-surface elimination in the mesh, and the shading command controls the shading model.

## Examples

### Display Contour Plot Under Mesh Plot

Use meshc to display a combination of a mesh plot and a contour plot of the peaks function.

```
figure
[X,Y] = meshgrid(-3:.125:3);
Z = peaks(X,Y);
meshc(Z);
```

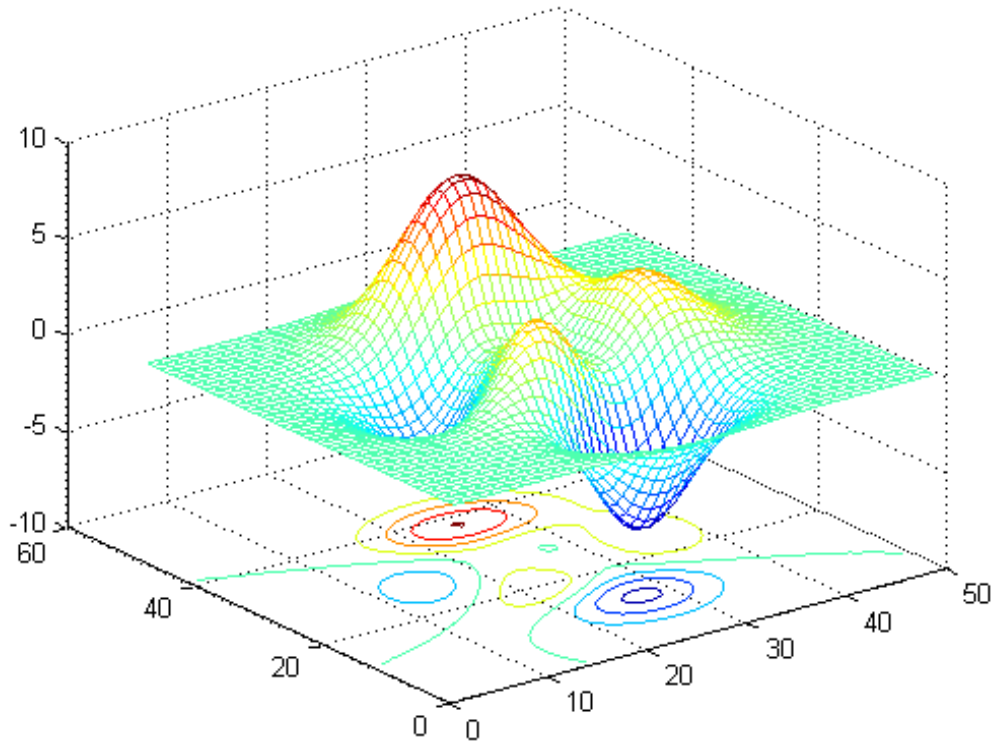

## Algorithms

The range of X, Y, and Z, or the current settings of the axes `XLimMode`, `YLimMode`, and `ZLimMode` properties, determine the axis limits. `axis` sets these properties.

The range of C, or the current settings of the axes `CLim` and `CLimMode` properties (also set by the `caxis` function), determine the color scaling. The scaled color values are used as indices into the current colormap.

The mesh rendering functions produce color values by mapping the  $z$  data values (or an explicit color array) onto the current colormap. The

# meshc

---

MATLAB default behavior is to compute the color limits automatically using the minimum and maximum data values (also set using `caxis auto`). The minimum data value maps to the first color value in the colormap and the maximum data value maps to the last color value in the colormap. MATLAB performs a linear transformation on the intermediate values to map them to the current colormap.

`meshc` calls `mesh`, turns `hold` on, and then calls `contour` and positions the contour on the  $x$ - $y$  plane. For additional control over the appearance of the contours, issue these commands directly. You can combine other types of graphs in this manner, for example `surf` and `pcolor` plots.

`meshc` assumes that  $X$  and  $Y$  are monotonically increasing. If  $X$  or  $Y$  is irregularly spaced, `contour3` calculates contours using a regularly spaced contour grid, and then it transforms the data to  $X$  or  $Y$ .

## See Also

`mesh` | `meshz` | `contour` | `hidden` | `meshgrid` | `surface` | `surf` | `surfc` | `surf1` | `waterfall` | `axis` | `caxis` | `colormap` | `hold` | `shading` | `view`

**Purpose** Plot a curtain around mesh plot

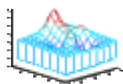

**Syntax**

```
meshz(X,Y,Z)
meshz(Z)
meshz(...,C)
meshz(axes_handles,...)
h = meshz(...)
```

**Description** `meshz(X,Y,Z)` draws a curtain around the wireframe mesh with color determined by `Z`, so color is proportional to surface height. If `X` and `Y` are vectors, `length(X) = n` and `length(Y) = m`, where `[m,n] = size(Z)`. In this case, `(X(j), Y(i), Z(i,j))` are the intersections of the wireframe grid lines; `X` and `Y` correspond to the columns and rows of `Z`, respectively. If `X` and `Y` are matrices, `(X(i,j), Y(i,j), Z(i,j))` are the intersections of the wireframe grid lines.

`meshz(Z)` draws a curtain around the wireframe mesh using `X = 1:n` and `Y = 1:m`, where `[m,n] = size(Z)`. The height, `Z`, is a single-valued function defined over a rectangular grid. Color is proportional to surface height.

`meshz(...,C)` draws a `meshz` graph with color determined by matrix `C`. MATLAB performs a linear transformation on the data in `C` to obtain colors from the current colormap. If `X`, `Y`, and `Z` are matrices, they must be the same size as `C`.

`meshz(axes_handles,...)` plots into the axes with handle `axes_handle` instead of the current axes (`gca`).

`h = meshz(...)` returns a handle to a `Surfaceplot` graphics object.

**Tips** `meshz` does not accept complex inputs.

A mesh is drawn as a `Surfaceplot` graphics object with the viewpoint specified by `view(3)`. The face color is the same as the background

color (to simulate a wireframe with hidden-surface elimination), or none when drawing a standard see-through wireframe. The current colormap determines the edge color. The hidden command controls the simulation of hidden-surface elimination in the mesh, and the shading command controls the shading model.

## Examples

### Curtain Plot of Peaks Function

Generate a curtain plot of the peaks function using meshz.

```
figure
[X,Y] = meshgrid(-3:.125:3);
Z = peaks(X,Y);
meshz(Z);
```



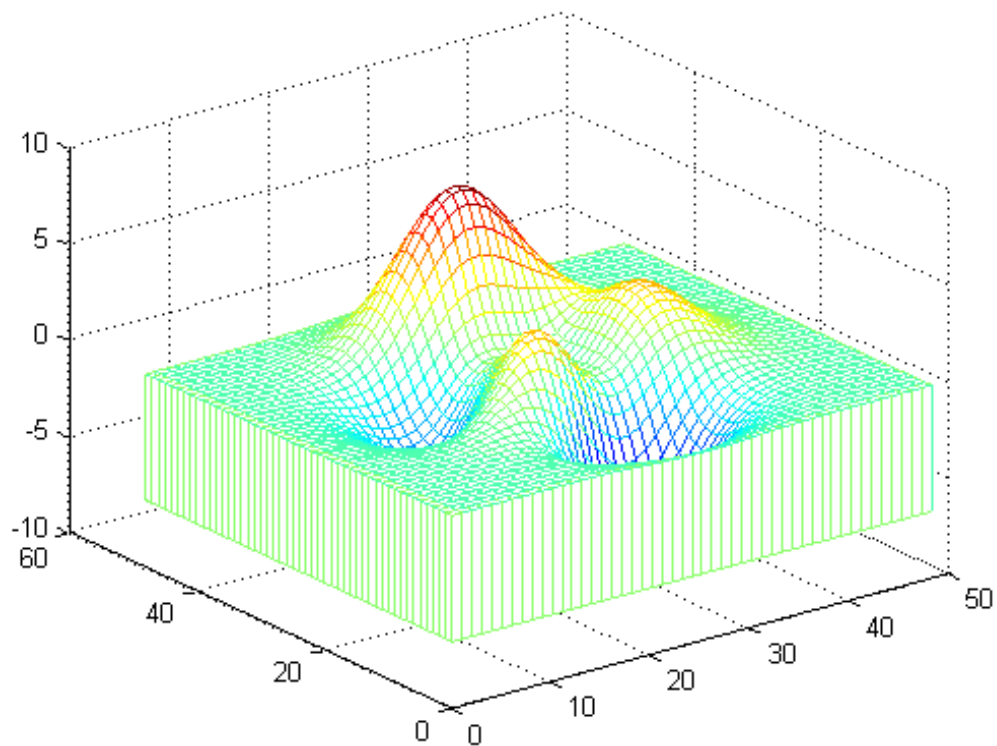

### Specify Color for Curtain Plot

Specify a color matrix for a curtain plot.

```
[X,Y] = meshgrid(-3:.125:3);
Z = peaks(X,Y);
C = gradient(Z);
```

```
figure
meshz(X,Y,Z,C)
```

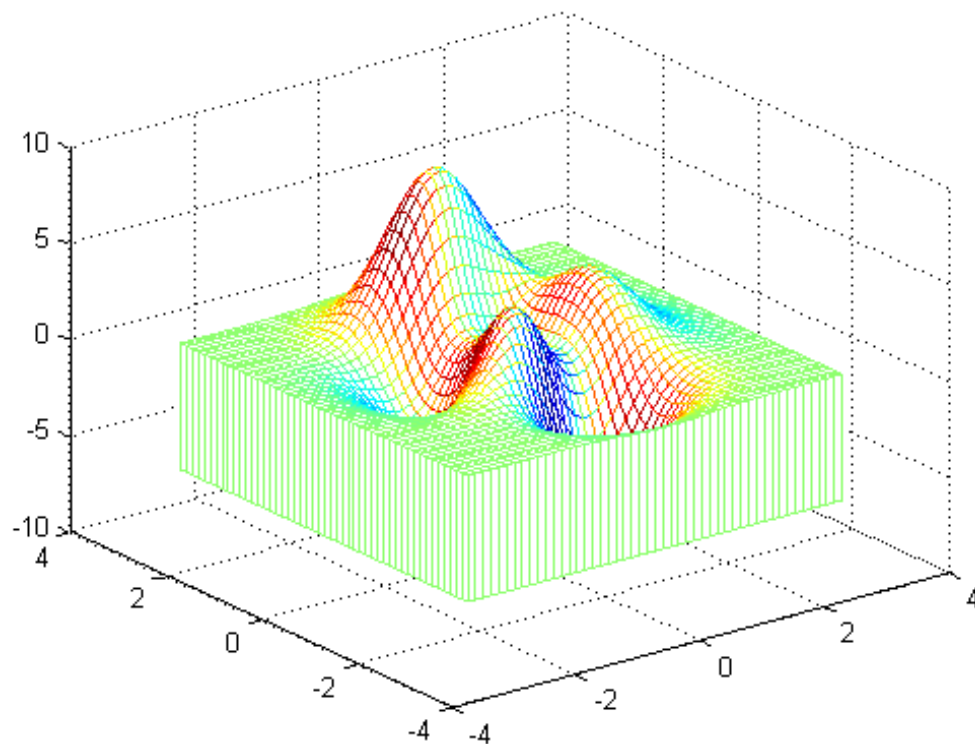

## See Also

[mesh](#) | [meshc](#) | [contour](#) | [hidden](#) | [meshgrid](#) | [surface](#) | [surf](#) | [surfc](#) | [surfl](#) | [waterfall](#) | [axis](#) | [caxis](#) | [colormap](#) | [hold](#) | [shading](#) | [view](#)

<b>Purpose</b>	Rectangular grid in 2-D and 3-D space
<b>Syntax</b>	<pre>[X,Y] = meshgrid(xgv,ygv) [X,Y,Z] = meshgrid(xgv,ygv,zgv) [X,Y] = meshgrid(gv) [X,Y,Z] = meshgrid(gv)</pre>
<b>Description</b>	<p><code>[X,Y] = meshgrid(xgv,ygv)</code> replicates the grid vectors <code>xgv</code> and <code>ygv</code> to produce a full grid. This grid is represented by the output coordinate arrays <code>X</code> and <code>Y</code>. The output coordinate arrays <code>X</code> and <code>Y</code> contain copies of the grid vectors <code>xgv</code> and <code>ygv</code> respectively. The sizes of the output arrays are determined by the length of the grid vectors. For grid vectors <code>xgv</code> and <code>ygv</code> of length <code>M</code> and <code>N</code> respectively, <code>X</code> and <code>Y</code> will have <code>N</code> rows and <code>M</code> columns.</p> <p><code>[X,Y,Z] = meshgrid(xgv,ygv,zgv)</code> produces three-dimensional coordinate arrays. The output coordinate arrays <code>X</code>, <code>Y</code>, and <code>Z</code> contain copies of the grid vectors <code>xgv</code>, <code>ygv</code>, and <code>zgv</code> respectively. The sizes of the output arrays are determined by the length of the grid vectors. For grid vectors <code>xgv</code>, <code>ygv</code>, and <code>zgv</code> of length <code>M</code>, <code>N</code>, and <code>P</code> respectively, <code>X</code>, <code>Y</code>, and <code>Z</code> will have <code>N</code> rows, <code>M</code> columns, and <code>P</code> pages.</p> <p><code>[X,Y] = meshgrid(gv)</code> is the same as <code>[X,Y] = meshgrid(gv,gv)</code>. In other words, you can reuse the same grid vector in each respective dimension. The dimensionality of the output arrays is determined by the number of output arguments.</p> <p><code>[X,Y,Z] = meshgrid(gv)</code> is the same as <code>[X,Y,Z] = meshgrid(gv,gv,gv)</code>. Again, the dimensionality of the output arrays is determined by the number of output arguments.</p> <p>The output coordinate arrays are typically used to evaluate functions of two or three variables. They are also frequently used to create surface and volumetric plots.</p>
<b>Input Arguments</b>	<p><b>xgv,ygv,zgv</b></p> <p>Grid vectors specifying a series of grid point coordinates in the <code>x</code>, <code>y</code> and <code>z</code> directions, respectively.</p>

# meshgrid

---

## **gv**

Generic grid vector specifying a series of point coordinates.

## **Output Arguments**

### **X,Y,Z**

Output arrays that specify the full grid.

## **Tips**

The `meshgrid` function is similar to `ndgrid`, however `meshgrid` is restricted to 2-D and 3-D while `ndgrid` supports 1-D to N-D. The coordinates output by each function are the same, but the shape of the output arrays in the first two dimensions are different. For grid vectors `x1gv`, `x2gv` and `x3gv` of length `M`, `N` and `P` respectively, `meshgrid(x1gv, x2gv)` will output arrays of size `N-by-M` while `ndgrid(x1gv, x2gv)` outputs arrays of size `M-by-N`. Similarly, `meshgrid(x1gv, x2gv, x3gv)` will output arrays of size `N-by-M-by-P` while `ndgrid(x1gv, x2gv, x3gv)` outputs arrays of size `M-by-N-by-P`. See “Grid Representation” in the MATLAB Mathematics documentation for more information.

## **Examples**

### **2-D Grid From Vectors**

Create a full grid from two monotonically increasing grid vectors:

```
[X,Y] = meshgrid(1:3,10:14)
```

```
X =
```

```
 1 2 3
 1 2 3
 1 2 3
 1 2 3
 1 2 3
```

```
Y =
```

```
 10 10 10
 11 11 11
 12 12 12
 13 13 13
 14 14 14
```

**Plot 3-D Functional Surface**

Use meshgrid to create a gridded  $(X,Y)$  domain.

```
[X,Y] = meshgrid(-2:.2:2, -2:.2:2);
```

Evaluate the function  $z(x,y) = xe^{-x^2-y^2}$  over this domain and generate a surface plot of the results.

```
Z = X .* exp(-X.^2 - Y.^2);
surf(X,Y,Z)
```

# meshgrid

---

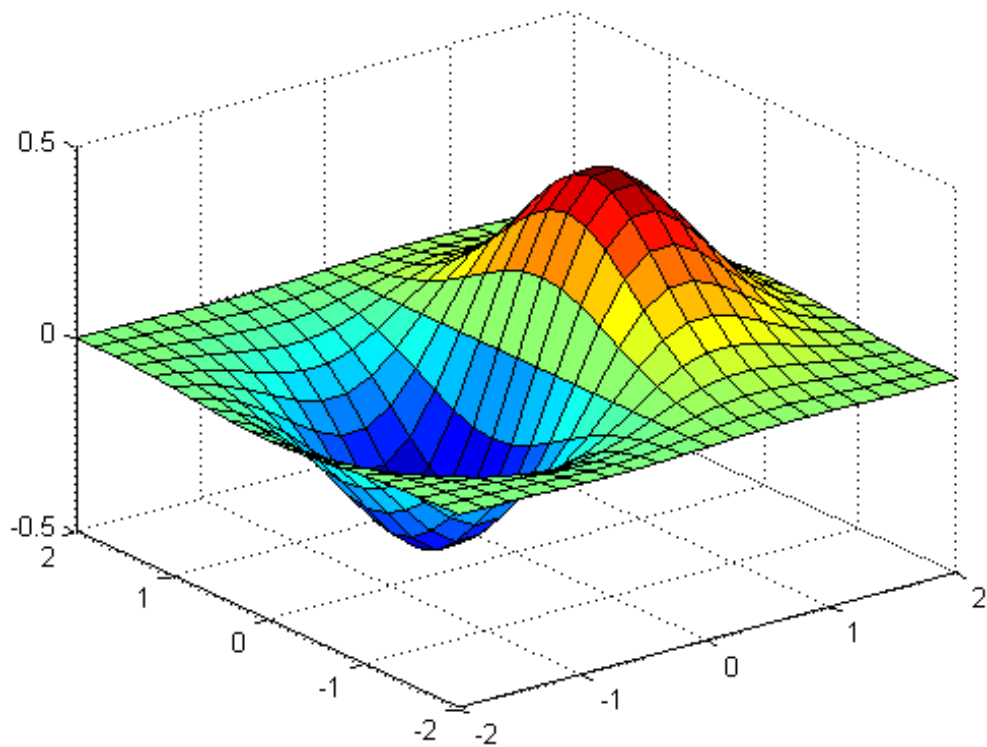

## See Also

[griddedInterpolant](#) | [mesh](#) | [ndgrid](#) | [surf](#)

## How To

- “Interpolating Gridded Data”

## Purpose

`meta.class` class describes MATLAB classes

## Description

Instances of the `meta.class` class contains information about MATLAB classes. The read/write properties of the `meta.class` class correspond to class attributes and are set only from within class definitions on the `classdef` line. You can query the read-only properties of the `meta.class` object to obtain information that is specified syntactically by the class (for example, to obtain the name of the class).

You cannot instantiate a `meta.class` object directly. You can construct a `meta.class` object from an instance of a class or using the class name:

- `metaclass` — returns a `meta.class` object representing the object passed as an argument.
- `?ClassName` — returns a `meta.class` object representing the named class.
- `fromName` — static method returns a `meta.class` object representing the named class.

For example, the `metaclass` function returns the `meta.class` object representing `MyClass`.

```
ob = MyClass;
obmeta = metaclass(ob);
obmeta.Name
ans =
MyClass
```

You can use the class name to obtain the `meta.class` object:

```
obmeta = ?MyClass;
```

You can also use the `fromName` static method:

```
obmeta = meta.class.fromName('MyClass');
```

# meta.class

---

## Properties

Property	Purpose
Abstract attribute, default = false	If true, this class is an abstract class (cannot be instantiated).  See “Defining Abstract Classes” for more information.
AllowedSubclasses attribute, write only from <code>classdef</code> statement	List classes that can subclass this class. Specify subclasses as <code>meta.class</code> objects in the form: <ul style="list-style-type: none"><li>• A single <code>meta.class</code> object</li><li>• A cell array of <code>meta.class</code> objects</li></ul> Specify <code>meta.class</code> objects using the <code>?ClassName</code> syntax only.
ConstructOnLoad attribute, default = false	If true, MATLAB calls the class constructor automatically when loading an object from a MAT-file. Therefore, the construction must be implemented so that calling it with no arguments does not produce an error.  See “Tips for Saving and Loading”
ContainingPackage read only	A <code>meta.package</code> object describing the package within which this class is contained, or an empty object if this class is not in a package.  See “Packages Create Namespaces”.
Description read only	Currently not used
DetailedDescription read only	Currently not used



<b>Property</b>	<b>Purpose</b>
Enumeration attribute, default = false	If true, this class is an enumeration class. See “Working with Enumerations”.
EventList read only	An array of meta.event objects describing each event defined by this class, including all inherited events.  See “Events”.
Events read only Use EventList instead	A cell array of meta.event objects describing each event defined by this class, including all inherited events.
EnumerationMemberList	An array of meta.EnumeratedValue objects describing the member names defined by an enumeration class.  See “Enumerations” for more information on enumeration classes.
EnumeratedValues read only Use EnumeratedMemberList instead	A cell array of meta.EnumeratedValue objects describing the member names defined by an enumeration class.  See “Enumerations” for more information on enumeration classes.
Hidden attribute, default = false	If set to true, the class does not appear in the output of MATLAB commands or tools that display class names.
InferiorClasses attribute, default = {}	A cell array of meta.class objects defining the precedence of classes represented by the list as inferior to this class.  See “Class Precedence”

# meta.class

---

Property	Purpose
MethodList read only	An array of <code>meta.method</code> objects describing each method defined by this class, including all inherited public and protected methods. See “How to Use Methods”.
Methods read only Use MethodList instead	A cell array of <code>meta.method</code> objects describing each method defined by this class, including all inherited public and protected methods.
Name read only	Name of the class associated with this <code>meta.class</code> object (char array)
PropertyList read only	An array of <code>meta.property</code> objects describing each property defined by this class, including all inherited public and protected properties. See “Properties”.
Properties read only Use PropertyList instead	A cell array of <code>meta.property</code> objects describing each property defined by this class, including all inherited public and protected properties. See “Properties”.
Sealed attribute, default = false	If true, the class cannot be subclassed.
SuperClassList read only	An array of <code>meta.class</code> objects describing each direct superclass from which this class is derived. See “Creating Subclasses — Syntax and Techniques”.
SuperClasses read only Use SuperClassList instead	A cell array of <code>meta.class</code> objects describing each direct superclass from which this class is derived.

## Methods

Method	Purpose
<code>fromName</code>	Returns the <code>meta.class</code> object associated with the specified class name.
<code>tf = eq(Cls)</code>	Equality function ( <code>a == b</code> ). Use to test if two variables refer to equal classes (classes that contain exactly the same list of elements).
<code>tf = ne(Cls)</code>	Not equal function ( <code>a ~= b</code> ). Use to test if two variables refer to different meta-classes.
<code>tf = lt(ClsA, ClsB)</code>	Less than function ( <code>ClsA &lt; ClsB</code> ). Use to determine if <code>ClsA</code> is a strict subclass of <code>ClsB</code> (i.e., a strict subclass means <code>ClsX &lt; ClsX</code> is false).
<code>tf = le(ClsA, ClsB)</code>	Less than or equal to function ( <code>ClsA &lt;= ClsB</code> ). Use to determine if <code>ClsA</code> is a subclass of <code>ClsB</code> .
<code>tf = gt(ClsA, ClsB)</code>	Greater than function ( <code>ClsB &gt; ClsA</code> ). Use to determine if <code>ClsB</code> is a strict superclass of <code>ClsA</code> (i.e., a strict superclass means <code>ClsX &gt; ClsX</code> is false).
<code>tf = ge(ClsA, ClsB)</code>	Greater than or equal to function ( <code>ClsB &gt;= ClsA</code> ). Use to determine if <code>ClsB</code> is a superclass of <code>ClsA</code> .

# meta.class

---

## Events

Event	Purpose
InstanceCreated	If the class is a handle class, this event occurs every time a new instance of this handle class is created, including new instances of any subclasses. The event occurs immediately after all constructor functions finish executing.
InstanceDestroyed	If the class is a handle class, this event occurs every time an instance of this handle class is destroyed, including all subclasses. The event occurs immediately before any destructor functions execute.

## Examples

Find property attributes using the `handle class findobj` method and the `audioplayer meta.class` object. Determine if a class defines the property named `SampleRate` and does it have public set access.

```
mc = ?audioplayer;
mp = findobj(mc.PropertyList, 'Name', 'SampleRate');
strcmp(mp.SetAccess, 'public')
...
```

## See Also

[fromName](#) | [meta.property](#) | [meta.method](#) | [meta.event](#) | [meta.package](#)

## How To

- “Getting Information About Classes and Objects”

**Purpose** Return meta.class object associated with named class

**Syntax** `mcls = meta.class.fromName('ClassName')`

**Description** `mcls = meta.class.fromName('ClassName')` is a static method that returns the meta.class object associated with the class *ClassName*. Note that you can also use the ? operator to obtain the meta.class object for a class name:

```
mcls = ?ClassName;
```

The equivalent call to `meta.class.fromName` is:

```
mcls = meta.class.fromName('ClassName');
```

Use `meta.class.fromName` when using a char variable for the class name:

```
function mcls = getMetaClass(cname)
 % Do error checking
 mcls = meta.class.fromName(cname);
 ...
end
```

**See Also** `meta.class`

# meta.DynamicProperty

---

## Purpose

`meta.DynamicProperty` class describes dynamic property of MATLAB object

## Description

The `meta.DynamicProperty` class contains descriptive information about dynamic properties that you have added to an instance of a MATLAB classes. The MATLAB class must be a subclass of `dynamicprops`. The properties of the `meta.DynamicProperty` class correspond to property attributes that you specify from within class definitions. Dynamic properties are not defined in `classdef` blocks, but you can set their attributes by setting the `meta.DynamicProperty` object properties.

You add a dynamic property to an object using the `addprop` method of the `dynamicprops` class. The `addprop` method returns a `meta.DynamicProperty` instance representing the new dynamic property. You can modify the properties of the `meta.DynamicProperty` object to set the attributes of the dynamic property or to add set and get access methods, which would be defined in the `classdef` for regular properties.

You cannot instantiate the `meta.DynamicProperty` class. You must use `addprop` to obtain a `meta.DynamicProperty` object.

To remove the dynamic property, call the `delete` handle class method on the `meta.DynamicProperty` object.

Obtain a `meta.DynamicProperty` object from the `addprops` method, which returns an array of `meta.DynamicProperty` objects, one for each dynamic property.

See “Dynamic Properties — Adding Properties to an Instance” for more information.

## Properties

Property	Purpose
Name	Name of the property.
Description	Currently not used

Property	Purpose
DetailedDescription	Currently not used
AbortSet	If true, and this property belongs to a handle class, then MATLAB does not set the property value if the new value is the same as the current value. This approach prevents the triggering of property PreSet and PostSet events.
Abstract attribute, default = false	If true, the property has no implementation, but a concrete subclass must redefine this property without Abstract being set to true. <ul style="list-style-type: none"><li>• Abstract properties cannot define set or get access methods. See “Property Access Methods”</li><li>• Abstract properties cannot define initial values. “Assigning a Default Value”</li><li>• All subclasses must specify the same values as the superclass for the property SetAccess and GetAccess attributes.</li><li>• Abstract=true should be used with the class attribute Sealed=false (the default).</li></ul>

# meta.DynamicProperty

Property	Purpose
Access	<p>public – unrestricted access</p> <p>protected – access from class or subclasses</p> <p>private – access by class members only (not subclasses)</p> <p>List of classes that have get and set access to this property. Specify classes as <code>meta.class</code> objects in the form:</p> <ul style="list-style-type: none"><li>• A single <code>meta.class</code> object</li><li>• A cell array of <code>meta.class</code> objects. An empty cell array, <code>{}</code>, is the same as <code>private</code> access.</li></ul> <p>Use <code>Access</code> to set both <code>SetAccess</code> and <code>GetAccess</code> to the same value. Query the values of <code>SetAccess</code> and <code>GetAccess</code> directly (not <code>Access</code>).</p>
Constant attribute, default = false	<p>Set to <code>true</code> if you want only one value for this property in all instances of the class.</p> <ul style="list-style-type: none"><li>• Subclasses inherit constant properties, but cannot change them.</li><li>• Constant properties cannot be <code>Dependent</code></li><li>• <code>SetAccess</code> is ignored.</li></ul> <p>See “Properties with Constant Values”</p>
DefaultValue	<p>Querying this property returns an error because dynamic properties cannot define default values.</p>



Property	Purpose
DefiningClass	The meta.class object representing the class that defines this property.
GetAccess attribute, default = public	public – unrestricted access protected – access from class or subclasses private – access by class members only
SetAccess attribute, default = public	public – unrestricted access protected – access from class or subclasses private – access by class members only
Dependent attribute, default = false	If false, property value is stored in object. If true, property value is not stored in object and the set and get functions cannot access the property by indexing into the object using the property name.  See “Property Get Methods”
Transient attribute, default = false	If true, property value is not saved when object is saved to a file. See “Understanding the Save and Load Process” for more about saving objects.
Hidden attribute, default = false	Determines whether the property should be shown in a property list (e.g., Property Inspector, call to properties, etc.).
GetObservable attribute, default = false	If true, and it is a handle class property, then listeners can be created for access to this property. The listeners are called whenever property values are queried. See “Property-Set and Query Events”

# meta.DynamicProperty

---

Property	Purpose
SetObservable attribute, default = false	If true, and it is a handle class property, then listeners can be created for access to this property. The listeners are called whenever property values are modified. See “Property-Set and Query Events”
GetMethod	Function handle of the get method associated with this property. Empty if there is no get method specified. See “Get Method Syntax”
SetMethod	Function handle of the set method associated with this property. Empty if there is no set method specified. See “Property Set Methods”
HasDefault	Always false. Dynamic properties cannot define default values.

## Events

See “Listen for Changes to Property Values” for information on using property events.

Event Name	Purpose
PreGet	Event occurs just before property is queried.
PostGet	Event occurs just after property has been queried
PreSet	Event occurs just before this property is modified
PostSet	Event occurs just after this property has been modified
ObjectBeingDestroyed	Inherited from handle

## See Also

addprop | handle

## Purpose

Describes enumeration members of MATLAB class

## Description

The `meta.EnumeratedValue` class contains information about enumeration members defined by MATLAB classes. The properties of a `meta.EnumeratedValue` object correspond to the attributes of the enumeration member being described.

All `meta.EnumeratedValue` properties are read-only. Query the `meta.EnumeratedValue` object to obtain information about the enumeration member it describes.

Obtain a `meta.EnumeratedValue` object from the `EnumerationMemberList` property of the `meta.class` object. `EnumerationMemberList` is an array of `Meta.EnumeratedValue` instances, one per enumeration member.

The `meta.EnumeratedValue` class is a subclass of the `handle` class.

## Example

To access the `meta.EnumeratedValue` objects for a class, first create a `meta.class` object for that class. For example, give the following `OnOff` class definition:

```
classdef OnOff < logical
 enumeration
 On (true)
 Off (false)
 end
end
```

Obtain a `meta.EnumeratedValue` object from the `EnumerationMemberList` property of the `meta.class` object:

```
% Obtain the meta.class instance for the OnOff class
mc = ?OnOff;
% Get the array of EnumerateValue objects
enumList = mc.EnumerationMemberList;
% Access the Name property of the first object in the array
enumList(1).Name =
```

# meta.EnumeratedValue

---

```
ans =
On
```

## Properties

Property	Purpose
Name read only	Name of the enumeration member associated with this meta.EnumeratedValue object
Description read only	This property is not used
DetailedDescription read only	This property is not used

## Methods

See the handle superclass for inherited methods.

## Events

See the handle superclass for inherited events.

## See Also

[meta.class](#) | [meta.property](#) | [meta.method](#) | [meta.event](#)

## How To

- “Working with Enumerations”
- “Getting Information About Classes and Objects”

**Purpose**

meta.event class describes MATLAB class events

**Description**

The meta.event class provides information about MATLAB class events. The read/write properties of the meta.event class correspond to event attributes and are specified only from within class definitions.

You can query the read-only properties of the meta.event object to obtain information that is specified syntactically by the class (for example, to obtain the name of the class defining the event).

You cannot instantiate a meta.event object directly. Obtain a meta.event object from the meta.class EventList property, which contains an array of meta.event objects, one for each event defined by the class. For example, replace *ClassName* with the name of the class whose events you want to query:

```
mco = ?ClassName;
elist = mco.EventList;
elist(1).Name; % name of first event in list
```

Use the metaclass function to obtain a meta.class object from a class instance:

```
mco = metaclass(obj);
```

**Properties**

Property	Purpose
Name read only	Name of the event.
Description read only	Currently not used
DetailedDescription read only	Currently not used

# meta.event

---

Property	Purpose
Hidden	If true, the event does not appear in the list of events returned by the <code>events</code> function (or other event listing functions or viewers)
ListenAccess	<p>Determines where you can create listeners for the event.</p> <ul style="list-style-type: none"><li>• <code>public</code> — unrestricted access</li><li>• <code>protected</code> — access from methods in class or subclasses</li><li>• <code>private</code> — access by class methods only (not from subclasses)</li><li>• List classes that have listen access to this event. Specify classes as <code>meta.class</code> objects in the form:<ul style="list-style-type: none"><li>▪ A single <code>meta.class</code> object</li><li>▪ A cell array of <code>meta.class</code> objects. An empty cell array, <code>{}</code>, is the same as <code>private</code> access.</li></ul></li></ul> <p>See “Controlling Access to Class Members”</p>

Property	Purpose
NotifyAccess	<p>Determines where code can trigger the event.</p> <ul style="list-style-type: none"> <li>• <code>public</code> — any code can trigger event</li> <li>• <code>protected</code> — can trigger event from methods in class or subclasses</li> <li>• <code>private</code> — can trigger event by class methods only (not from subclasses)</li> <li>• List classes that have notify access to this event. Specify classes as <code>meta.class</code> objects in the form: <ul style="list-style-type: none"> <li>▪ A single <code>meta.class</code> object</li> <li>▪ A cell array of <code>meta.class</code> objects. An empty cell array, <code>{}</code>, is the same as <code>private</code> access.</li> </ul> </li> </ul> <p>See “Controlling Access to Class Members”</p>
DefiningClass	<p>The <code>meta.class</code> object representing the class that defines this event.</p>

**See Also**

`meta.class` | `meta.property` | `meta.method` | `metaclass`

**How To**

- “Events”
- “Getting Information About Classes and Objects”

# meta.MetaData

---

<b>Superclasses</b>	Heterogeneous
<b>Purpose</b>	Superclass for MATLAB object metadata
<b>Description</b>	<p>The <code>meta.MetaData</code> class of objects represent MATLAB class definitions and the constituent parts of those definitions, such as properties and methods. Metadata enable a program to get information about a class definition.</p> <p>The <code>meta.MetaData</code> class forms the root of the metadata class hierarchy, which enables the formation of arrays of metadata objects belonging to different specific classes.</p> <p>MATLAB uses instances of the <code>meta.MetaData</code> class as the default object to fill in missing array elements.</p> <p><code>findobj</code> and <code>findprop</code>, can search the metadata hierarchy and return an array of different metadata objects. These function require the ability to form heterogeneous arrays containing various metaclass objects.</p> <p>See the <code>matlab.mixin.Heterogeneous</code> class for more information on heterogeneous hierarchies.</p>
<b>Construction</b>	You cannot create an instance of the <code>meta.MetaData</code> class directly. MATLAB constructs instances of this class as required.
<b>Copy Semantics</b>	Handle. To learn how handle classes affect copy operations, see Copying Objects in the MATLAB documentation.
<b>Examples</b>	<p>This example shows how the <code>meta.MetaData</code> class facilitates working with metaclasses.</p> <p>Create a <code>meta.class</code> instance representing the MATLAB <code>timeseries</code> class:</p> <pre>&gt;&gt; mc = ?timeseries;</pre> <p>MATLAB uses <code>meta.MetaData</code> objects to fill empty array elements:</p>



```
>> m(2) = mc
>> class(m(1))
```

```
ans =
```

```
meta.MetaData
>> class(m(2))
```

```
ans =
```

```
meta.class
```

Use `findobj` to find all properties and methods that have protected access:

```
>> protectedMembers = findobj(mc,{'Access','protected'},...
'-or',{'SetAccess','protected'},...
'-or',{'GetAccess','protected'}});
```

The `timeseries` class defines both properties and methods that have protected access. Therefore, `findobj` returns a heterogeneous array of class `meta.MetaData`. This array contains both `meta.property` and `meta.method` objects.

```
>> protectedMembers
```

```
protectedMembers =
```

```
11x1 heterogeneous meta.MetaData (meta.property, meta.method)
```

```
handle with no properties.
```

```
Package: meta
```

```
>> class(protectedMembers(1))
```

```
ans =
```

```
meta.property
```

```
>> protectedMembers(1).Name
```

```
ans =

Length
>> protectedMembers(1).SetAccess

ans =

protected
>> protectedMembers(1).GetAccess

ans =

public
```

## See Also

`handle` | `matlab.mixin.Heterogeneous`

## How To

- [Class Attributes](#)
- [Property Attributes](#)
- [“Getting Information About Classes and Objects”](#)

## Purpose

meta.method class describes MATLAB class methods

## Description

The meta.method class provides information about the methods of MATLAB classes. The read/write properties of the meta.method class correspond to method attributes and are specified only from within class definitions.

You can query the read-only properties of the meta.method object to obtain information that is specified syntactically by the class (for example, to obtain the name of the class defining a method).

You cannot instantiate a meta.method object directly. Obtain a meta.method object from the meta.class MethodList property, which contains an array of meta.method objects, one for each class method. For example, replace *ClassName* with the name of the class whose methods you want to query:

```
mco = ?ClassName;
mlist = mco.MethodList;
mlist(1).Name; % name of first method in the list
```

Use the metaclass function to obtain a meta.class object from a class instance:

```
mco = metaclass(obj);
```

## Properties

Property	Purpose
Abstract	<p>If true, the method has no implementation. The method has a syntax line that can include arguments, which subclasses use when implementing the method.</p> <ul style="list-style-type: none"> <li>Subclasses are not required to define the same number of input and output arguments.</li> </ul>

# meta.method

---

Property	Purpose
	<ul style="list-style-type: none"><li>• The method can have comments after the function line</li><li>• Does not contain function or end keywords, only the function syntax (e.g., <code>[a,b] = myMethod(x,y)</code>)</li></ul>
Access attribute, default = public	Determines what code can call this method. <ul style="list-style-type: none"><li>• <code>public</code> — unrestricted access</li><li>• <code>protected</code> — access from methods in class</li></ul>
DefiningClass	The <code>meta.class</code> object representing the class that defines this method.
Description read only	Currently not used
DetailedDescription read only	Currently not used
Hidden attribute, default = false	When <code>false</code> , the method name shows in the list of methods displayed using the <code>methods</code> or <code>methodsview</code> commands. If set to <code>true</code> , the method name is not included in these listings.
Name read only	Name of the method.

Property	Purpose
Sealed attribute, default = false	If true, the method cannot be redefined in a subclass. Attempting to define a method with the same name in a subclass causes an error.
Static attribute, default = false	Set to true to define a method that does not depend on an object of the class and does not require an object argument. Call static methods using the class name in place of the object:  <code>classname.methodname()</code>  Or with an instance of the class, like any method:  <code>o.methodname()</code>  See “Static Methods”

## See Also

[meta.class](#) | [meta.property](#) | [meta.event](#) | [metaclass](#)

## How To

- “Methods”
- “Getting Information About Classes and Objects”

# meta.package

---

**Purpose** meta.package class describes MATLAB packages

**Description** The meta.package class contains information about MATLAB packages. You cannot instantiate a meta.package object directly. Obtain a meta.package object from the meta.class ContainingPackage property, which contains a meta.package object, or an empty object, if the class is not in a package.

## Properties

Property	Purpose
Name read only	Name of the package associated with this meta.package object
ClassList read only	List of classes that are scoped to this package. An object array of meta.class objects.
Classes read only Use ClassList instead	List of classes that are scoped to this package. A cell array of meta.class objects.
FunctionList read only	List of functions that are scoped to this package. An object array of function handles.
Functions read only Use FunctionList instead	List of functions that are scoped to this package. A cell array of function handles.
PackageList read only	List of packages that are scoped to this package. An object array of meta.package objects.
Packages read only Use PackageList instead	List of packages that are scoped to this package. A cell array of meta.package objects.
ContainingPackage read only	A meta.package object describing the package within which this package is contained, or an empty object if this package is not nested.

## Methods

Method	Purpose
<code>fromName</code>	Static method returns a <code>meta.package</code> object for a specified package name.
<code>getAllPackages</code>	Static method returns a cell array of <code>meta.package</code> objects representing all top-level packages.

## See Also

`meta.class` | `meta.property` | `meta.method` | `meta.event`

## How To

- “Getting Information About Classes and Objects”

# meta.abstractDetails

---

**Purpose** Find abstract methods and properties

**Syntax**

```
meta.abstractDetails(ClassName)
meta.abstractDetails(mc)
absMembers = meta.abstractDetails(___)
```

**Description** `meta.abstractDetails(ClassName)` displays a list of abstract methods and properties for the class with name `ClassName`. Use the fully specified name for classes in packages. MATLAB displays all public and protected abstract methods and properties, including those declared `Hidden`.

`meta.abstractDetails(mc)` displays a list of abstract methods and properties for the class represented by the `meta.class` object `mc`.

`absMembers = meta.abstractDetails( ___ )` returns an array of the metaclass objects corresponding to the abstract members of the class, and can include any of the input arguments in previous syntaxes. If the class has both abstract methods and abstract properties, `absMembers` is a heterogeneous array of class `meta.MetaData` containing `meta.method` and `meta.property` objects.

A class can be abstract without defining any abstract methods or properties if it declares the `Abstract` class attribute. In this case, `meta.abstractDetails` returns no abstract members for that class, but the class is abstract. See “Determine If a Class Is Abstract” for more information.

## Input Arguments

### **ClassName**

Name of the class specified as a character string (for example, 'MyClass')

### **mc**

`meta.class` object representing the class (for example, ?MyClass)



## Output Arguments

### **absMembers**

Array of metaclass objects representing abstract class members

## Examples

### **Display Abstract Member Names**

Define the class, `AbsBase`, with an abstract property:

```
classdef AbsBase
 properties (Abstract)
 Prop1
 end
 methods(AbsBase)
 result = methodOne(obj)
 output = methodTwo(obj)
 end
end
```

Pass the class name (`AbsBase`) as a string:

```
meta.abstractDetails('AbsBase')
```

`meta.abstractDetails` displays the names of the abstract properties and methods defined in the class `AbsBase`.

```
Abstract methods for class AbsBase:
 methodTwo % defined in AbsBase
 methodOne % defined in AbsBase
```

```
Abstract properties for class AbsBase:
 Prop1 % defined in AbsBase
```

### **Return Abstract Member Metaclass Objects**

Pass a `meta.class` object representing the `AbsBase` class and return the metaclass objects for the abstract members. Use the definition of the `AbsBase` class from the previous example.

```
mc = ?AbsBase;
```

# meta.abstractDetails

---

```
absMembers = meta.abstractDetails(mc);
```

absMembers is a heterogeneous array containing a meta.property object for the Prop1 abstract property and meta.method objects for the methodOne and methodTwo abstract methods.

List the names of the metaclass objects.

```
for k=1:length(absMembers)
 disp(absMembers(k).Name)
end
```

```
methodTwo
methodOne
Prop1
```

## Find Inherited Abstract Members

Derive the SubAbsBase class from AbsBase, which is defined in a previous example.

```
classdef SubAbsBase < AbsBase
 properties
 SubProp = 1;
 end
 methods
 function result = methodOne(obj)
 result = obj.SubProp + 1;
 end
 end
end
```

Display the names of the abstract members inherited by SubAbsBase.

```
meta.abstractDetails('SubAbsBase')
```

```
Abstract methods for class SubAbsBase:
 methodTwo % defined in AbsBase
```

```
Abstract properties for class SubAbsBase:
 Prop1 % defined in AbsBase
```

To make SubAbsBase a concrete class, you need to implement concrete versions of methodTwo and Prop1 in the subclass.

## See Also

`meta.class` | `meta.class.forName`

## Concepts

- “Defining Abstract Classes”
- “Getting Information About Classes and Objects”

# meta.package.fromName

---

**Purpose** Return meta.package object for specified package

**Syntax** `mpkg = meta.package.fromName('pkgname')`

**Description** `mpkg = meta.package.fromName('pkgname')` is a static method that returns the meta.package object associated with the named package. If `pkgname` is a nested package, then you must provide the fully qualified name (e.g., 'pkgname1.pkgname2').

**Examples** List the classes in the event package:

```
mev = meta.package.fromName('event');
for k=1:length(mev.Classes)
 disp(mev.Classes{k}.Name)
end
event.EventData
event.PropertyEvent
event.listener
event.propListener
```

**See Also** `meta.package` | `meta.package.getAllPackages`

**Purpose** Get all top-level packages

**Syntax** `P = meta.package.getAllPackages`

**Description** `P = meta.package.getAllPackages` is a static method that returns a cell array of `meta.package` objects representing all the top-level packages that are visible on the MATLAB path or defined as top-level built-in packages. You can access subpackages using the `Packages` property of each `meta.package` object.

Note that the time required to find all the packages on the path might be excessively long in some cases. You should therefore avoid using this method in any code where execution time is a consideration. `getAllPackages` is generally intended for interactive use only.

**See Also** `meta.package` | `meta.package.fromName`

# meta.property

---

**Purpose** meta.property class describes MATLAB class properties

**Description** The meta.property class provides information about the properties of MATLAB classes. The read/write properties of the meta.property class correspond to property attributes and are specified only from within your class definitions.

You can query the read-only properties of the meta.property object to obtain information that is specified syntactically by the class (for example, to obtain the function handle of a property's set access method).

You cannot instantiate a meta.property object directly. Obtain a meta.property object from the meta.class PropertyList property, which contains an array of meta.property objects, one for each class property. For example, replace *ClassName* with the name of the class whose properties you want to query:

```
mco = ?ClassName;
plist = mco.PropertyList;
plist(1).Name; % name of first property
```

Use the metaclass function to obtain a meta.class object from a class instance:

```
mco = metaclass(obj);
```

## Properties

Property	Purpose
Name read only	Name of the property.
Description read only	Currently not used
DetailedDescription read only	Currently not used

Property	Purpose
AbortSet attribute, default = false	<p>If true, and this property belongs to a handle class, then MATLAB does not set the property value if the new value is the same as the current value. This prevents the triggering of property PreSet and PostSet events.</p> <p>See “Listen for Changes to Property Values”</p>
Abstract attribute, default = false	<p>If true, the property has no implementation, but a concrete subclass must redefine this property without Abstract being set to true.</p> <ul style="list-style-type: none"> <li>• Abstract properties cannot define set or get access methods. See “Property Access Methods”</li> <li>• Abstract properties cannot define initial values. “Assigning a Default Value”</li> <li>• All subclasses must specify the same values as the superclass for the property SetAccess and GetAccess attributes.</li> <li>• Abstract=true should be used with the class attribute Sealed=false (the default).</li> </ul>
Access	<p>public – unrestricted access</p> <p>protected – access from class or subclasses</p> <p>private – access by class members only (not subclasses)</p> <p>List of classes that have get and set access to this property. Specify classes as meta.class objects in the form:</p> <ul style="list-style-type: none"> <li>• A single meta.class object</li> </ul>

# meta.property

---

Property	Purpose
	<ul style="list-style-type: none"><li>• A cell array of <code>meta.class</code> objects. An empty cell array, {}, is the same as <code>private</code> access.</li></ul> <p>Use <code>Access</code> to set both <code>SetAccess</code> and <code>GetAccess</code> to the same value. Query the values of <code>SetAccess</code> and <code>GetAccess</code> directly (not <code>Access</code>).</p>
Constant attribute, default = false	<p>Set to true if you want only one value for this property in all instances of the class.</p> <ul style="list-style-type: none"><li>• Subclasses inherit constant properties, but cannot change them.</li><li>• Constant properties cannot be <code>Dependent</code></li><li>• <code>SetAccess</code> is ignored.</li></ul> <p>See “Properties with Constant Values”</p>
DefaultValue	<p>Property default value (if specified in class definition). See also <code>HasDefault</code> property. Abstract, dependent and dynamic properties cannot specify default values.</p>
DefiningClass	<p>The <code>meta.class</code> object representing the class that defines this property.</p>



<b>Property</b>	<b>Purpose</b>
<p>GetAccess attribute, default = public</p>	<p>public – unrestricted access protected – access from class or subclasses private – access by class members only</p> <p>List classes that have get access to this property. Specify classes as <code>meta.class</code> objects in the form:</p> <ul style="list-style-type: none"> <li>• A single <code>meta.class</code> object</li> <li>• A cell array of <code>meta.class</code> objects. An empty cell array, {}, is the same as private access.</li> </ul> <p>See “Controlling Access to Class Members”</p>
<p>Dependent attribute, default = false</p>	<p>If false, property value is stored in object. If true, property value is not stored in object and the set and get functions cannot access the property by indexing into the object using the property name.</p> <p>See “Property Get Methods”</p>
<p>Transient attribute, default = false</p>	<p>If true, property value is not saved when object is saved to a file. See “Understanding the Save and Load Process” for more about saving objects.</p>
<p>GetMethod read only</p>	<p>Function handle of the get method associated with this property. Empty if there is no get method specified. See “Get Method Syntax”</p>

# meta.property

Property	Purpose
GetObservable attribute, default = false	If true, and it is a handle class property, then listeners can be created for access to this property. The listeners are called whenever property values are queried. See “Property-Set and Query Events”
HasDefault	Property contains a boolean value indicating if the property defines a default value. Test HasDefault before querying the DefaultValue property to avoid a MATLAB: class:NoDefaultDefined error.
Hidden attribute, default = false	Determines whether the property should be shown in a property list (e.g., Property Inspector, call to properties, etc.).
SetAccess attribute, default = public	<p>public – unrestricted access</p> <p>protected – access from class or subclasses</p> <p>private – access by class members only</p> <p>immutable — property can be set only in the constructor.</p> <p>See “Mutable and Immutable Properties”</p> <p>List classes that have set access to this property. Specify classes as meta.class objects in the form:</p> <ul style="list-style-type: none"><li>• A single meta.class object</li><li>• A cell array of meta.class objects. An empty cell array, {}, is the same as private access.</li></ul> <p>See “Controlling Access to Class Members”</p>

Property	Purpose
SetMethod read only	Function handle of the set method associated with this property. Empty if there is no set method specified. See “Property Set Methods”
SetObservable attribute, default = false	If true, and it is a handle class property, then listeners can be created for access to this property. The listeners are called whenever property values are modified. See “Property-Set and Query Events”

## Events

See “Listen for Changes to Property Values” for information on using property events.

Event Name	Purpose
PreGet	Event occurs just before property is queried.
PostGet	Event occurs just after property has been queried
PreSet	Event occurs just before this property is modified
PostSet	Event occurs just after this property has been modified

## See Also

`meta.class` | `meta.method` | `meta.event` | `metaclass`

## How To

- “Properties”
- “Getting Information About Classes and Objects”

# metaclass

---

**Purpose** Obtain `meta.class` object

**Syntax** `mc = metaclass(object)`  
`mc = ?ClassName`

**Description** `mc = metaclass(object)` returns the `meta.class` object for the class of `object`. The `object` input argument can be a scalar or an array of objects. However, `metaclass` always returns a scalar `meta.class` object.

`mc = ?ClassName` returns the `meta.class` object for the class with name, *ClassName*. The `?` operator works only with a class name, not an object.

If you pass a class name as a string to the `metaclass` function, it returns the `meta.class` object for the `char` class. Use the `?` operator or the `meta.class.fromName` method to obtain the `meta.class` object from a class name. Use this method if you want to pass the class name in a string variable.

**Examples** Return the `meta.class` object for an instance of the `MException` class:

```
obj = MException('Msg:ID', 'MsgTxt');
mc = metaclass(obj);
```

Use the `?` operator to get the `meta.class` object for the `hgsetget` class:

```
mc = ?hgsetget;
```

**See Also** `meta.class` | `meta.class.fromName`

**Tutorials** • “Class Metadata”

## Purpose

Class method names

## Syntax

```
methods('classname')
methods(..., '-full')
m = methods(...)
```

## Description

`methods('classname')` displays the names of the methods for the class *classname*. If *classname* is a MATLAB or Java class, then `methods` displays only public methods, including those methods inherited from superclasses.

`methods(..., '-full')` displays a full description of the methods, including inheritance information and, for MATLAB and Java methods, method attributes and signatures. `methods` does not remove duplicate method names with different signatures. Do not use this option with classes defined before MATLAB 7.6.

`m = methods(...)` returns the method names in a cell array of strings.

`methods` is also a MATLAB class-definition keyword. See `classdef` for more information on class-definition keywords.

This function does not show generic methods from classes based on the Microsoft .NET Framework. Use your product documentation to get information on generic methods.

## Examples

Retrieve the names of the static methods in class `MException`:

```
methods('MException')
```

```
Methods for class MException:
```

```
addCause getReport ne throw
eq isequal rethrow throwAsCaller
```

```
Static methods:
```

```
last
```

# methods

---

## **See Also**

[methodsview](#) | [properties](#) | [events](#) | [what](#) | [which](#)

## **Tutorials**

- [“Methods”](#)

**Purpose**

View class methods

**Syntax**

```
methodsview packagename.classname
methodsview classname
methodsview(object)
```

**Description**

`methodsview packagename.classname` displays information about the methods in the class, `classname`. If the class is in a package, include `packagename`. If `classname` is a MATLAB or Java class, `methodsview` lists only public methods, including those methods inherited from superclasses.

`methodsview classname` displays information describing the class `classname`.

`methodsview(object)` displays information about the methods of the class of `object`.

`methodsview` creates a window that displays the methods defined in the specified class. `methodsview` provides additional information like arguments, returned values, and superclasses. It also includes method qualifiers (for example, `abstract` or `synchronized`) and possible exceptions thrown.

**Examples**

List information on all methods in the `java.awt.MenuItem` class:

```
methodsview java.awt.MenuItem
```

MATLAB displays this information in a new window.

**See Also**

[methods](#) | [import](#) | [class](#) | [javaArray](#)

**Purpose** Build MEX-function from C/C++ or Fortran source code

**Syntax**

```
mex -setup

mex filenames
mex option1 ... optionN filenames

mex -setup lang
```

**Description** `mex filenames` compiles and links one or more C, C++, or Fortran source files into a binary MEX-file, callable from MATLAB. `filenames` specify the source files. Also builds executable files for standalone MATLAB engine and MAT-file applications.

MATLAB automatically selects a compiler, if installed, based on the language of the `filenames` arguments.

`mex option1 ... optionN filenames` builds with the specified build options. The `option1 ... optionN` arguments supplement or override the default mex build configuration.

`mex -setup lang` selects a compiler for the given `lang`. Use this option when you want to change the default compiler for the given language.

## Input Arguments

### **filenames - One or more file names**

string

One or more file names, including name and file extension, specified as a string. If the file is not in the current folder, specify the full path to the file. File names can be any combination of:

- C, C++, or Fortran language source files
- Simulink S-function files
- object files
- library files



The first file listed in `filenames` is the name of the binary MEX-file. To override this naming convention, use the `'-output'` option.

**Data Types**

char

**option1 ... optionN - One or more build options**

strings corresponding to valid option flags

One or more build options, specified as one of these values. Options can appear in any order on any platform, except where indicated.

Option	Description
<code>@rspfile</code>	Uses Windows RSP file. An RSP file is a text file containing command-line options.
<code>-c</code>	Compiles an object file only. Does not build a binary MEX-file.
<code>-client engine</code>	Build engine application.
<code>-compatibleArrayDims</code> (default) <code>-largeArrayDims</code>	Links with the specified MATLAB array-handling API. <ul style="list-style-type: none"> <li>• <code>-compatibleArrayDims</code> — Uses the MATLAB Version 7.2 array-handling API, which limits arrays to <math>2^{31}-1</math> elements. Default option.</li> <li>• <code>-largeArrayDims</code> — Uses the MATLAB large-array-handling API. This API handles arrays with more than <math>2^{31}-1</math> elements. Must use this option when calling LAPACK or BLAS functions.</li> </ul> In verbose mode ( <code>-v</code> option), if you do not specify either the <code>-compatibleArrayDims</code> or the <code>-largeArrayDims</code> option, MATLAB displays a message showing the default option.

(Continued)

Option	Description
<p>-D<i>symbolname</i>                      -D<i>symbolname</i>=<i>symbolvalue</i>                      -U<i>symbolname</i></p>	<p>The -D options define C preprocessor macros. Equivalent to the following in the source file:</p> <ul style="list-style-type: none"> <li>• #define <i>symbolname</i></li> <li>• #define <i>symbolname symbolvalue</i></li> </ul> <p>The -U option removes any initial definition of the C preprocessor macro, <i>symbolname</i>. Inverse of the -D option.</p> <p>Do not add a space between <b>D</b> or <b>U</b> and <i>symbolname</i>. Do not add spaces around the = sign.</p> <p>Example: “Define Directive” on page 1-4337</p>
<p>-f <i>filepath</i></p>	<p>To build engine applications, use the -client engine option.</p> <p>Specifies name and location of the mex configuration file. Overrides the default compiler selection. For information about using a non-default compiler, see “Changing Default Compiler”. <i>filepath</i> is the name and full path of the configuration file, specified as a string.</p>
<p>-g</p>	<p>Adds symbolic information and disables optimizing built object code. Use for debugging. To debug with optimization, add the -O option.</p>
<p>-h[elp]</p>	<p>Displays help for mex. Use from an operating system prompt.</p>

(Continued)

Option	Description
-I <i>pathname</i>	<p>Adds <i>pathname</i> to the list of folders to search for #include files.</p> <p>Do not add a space between <b>I</b> and <i>pathname</i>.</p> <p>Example: “Specify Path to Include File” on page 1-4335</p>
-llibname -Llibfolder -llibname	<p>Links with object library <i>libname</i> in (optional) <i>libfolder</i>.</p> <p>MATLAB expands <i>libname</i> to:</p> <ul style="list-style-type: none"> <li>• <i>libname.lib</i> or <i>liblibname.lib</i> — Windows systems</li> <li>• <i>liblibname.dylib</i> — Mac systems</li> <li>• <i>liblibname.so</i> — Linux systems</li> </ul> <p>If used, the -L option must precede the -l option. When using the -L option on Linux or Mac systems, you also must set the runtime library path, as explained in “Setting Run-Time Library Path”.</p> <p>Do not add a space between <b>l</b> and <i>libname</i> or between <b>L</b> and <i>libfolder</i>.</p> <p>Specify the -l option with the lowercase letter <b>L</b>.</p> <p>Example: “Specify Path to Library File” on page 1-4336</p>

**(Continued)**

<b>Option</b>	<b>Description</b>
<p>-largeArrayDims -compatibleArrayDims (default)</p>	<p>Links with the specified MATLAB array-handling API.</p> <ul style="list-style-type: none"> <li>-compatibleArrayDims — Uses the MATLAB Version 7.2 array-handling API, which limits arrays to <math>2^{31}-1</math> elements. Default option.</li> <li>-largeArrayDims — Uses the MATLAB large-array-handling API. This API handles arrays with more than <math>2^{31}-1</math> elements. Must use this option when calling LAPACK or BLAS functions.</li> </ul> <p>In verbose mode (-v option), if you do not specify either the -compatibleArrayDims or the -largeArrayDims option, MATLAB displays a message showing the default option.</p>
<p>-n</p>	<p>Displays, but does not execute, commands that mex would execute.</p> <p>Example: “Preview Build Commands” on page 1-4334</p>
<p>-O</p>	<p>Optimizes the object code. Use this option to compile with optimization.</p> <p>Optimization is enabled by default. Optimization is disabled when the -g option appears without the -O option.</p> <p>Specify this option with the capital letter <b>O</b>.</p>

(Continued)

Option	Description
-outdir <i>dirname</i>	Places all output files in folder <i>dirname</i> .  Example: “Create and Link to Separate Object Files” on page 1-4334
-output <i>mexname</i>	Overrides the default MEX-file naming mechanism. Creates binary MEX-file named <i>mexname</i> with the appropriate MEX-file extension.
-setup <i>lang</i>	Change the default compiler to build <i>lang</i> language MEX-files. When you use this option, all other command-line options are ignored.
-silent	Suppresses informational messages. The <code>mex</code> function still reports errors and warnings, even when you specify <code>-silent</code> .
-U <i>symbolname</i>	Removes any initial definition of the C preprocessor macro <i>symbolname</i> . (Inverse of the <code>-D</code> option.)  Do not add a space between <b>U</b> and <i>symbolname</i> .
-v	Builds in verbose mode. Displays values for internal variables after all command-line arguments are considered. Displays each compile and link step fully evaluated.  Example: “Display Detailed Build and Troubleshooting Information” on page 1-4334
<i>varname=varvalue</i>	Overrides default setting for variable <i>varname</i> . This option is processed after all command-line arguments are considered.

**(Continued)**

Option	Description
	Example: “Override Default Compiler Switch Option” on page 1-4337.

**lang - Language**

C (default) | C++ | CPP | Fortran

Language, specified as one of these values.

C	C compilers, including C++.
C++ or CPP	C++ compilers.
Fortran	Fortran compilers.

## Examples

### Build C MEX-File

Build a single C program, `yprime.c`, into a MEX-file.

Each example is based on MEX examples in the `matlabroot/extern/examples` subfolders. To build the example code, copy the source file to a writable folder on your path, such as `c:\work`. Set the current folder to `c:\work`.

```
[s,msg,msgid] = mkdir('c:\work');
if (isempty(msgid))
 mkdir('c:\work')
end
cd c:\work
```

Copy the source code, `yprime.c`.

```
copyfile(fullfile(matlabroot,'extern','examples','mex',...
 'yprime.c'),'.','f');
```

Build the MEX-file.

```
mex yprime.c
```

```
Building with 'Microsoft Visual C++ 2010 (C)'.
MEX completed successfully.
```

The output displays information specific to your compiler.

Test.

```
T=1; Y=1:4;
yprime(T,Y)
```

```
ans =
 2.0000 8.9685 4.0000 -1.0947
```

### **Build MEX-File from Multiple Source Files**

The MEX-file example, `fulltosparse`, consists of two Fortran source files, `loadsparse.F` and `fulltosparse.F`.

To run this example, you need a supported Fortran compiler installed on your system.

Copy the source files to the current folder.

```
copyfile(fullfile(matlabroot,'extern','examples','refbook',...
 'loadsparse.F'),'.','f');
copyfile(fullfile(matlabroot,'extern','examples','refbook',...
 'fulltosparse.F'),'.','f');
```

Build the `fulltosparse` MEX-file.

```
mex -largeArrayDims fulltosparse.F loadsparse.F
```

The MEX-file name is `fulltosparse` because `fulltosparse.F` is the first file on the command line.

Test.

```
full = eye(5);
```

```
spar = fulltosparse(full)
```

```
spar =
 (1,1) 1
 (2,2) 1
 (3,3) 1
 (4,4) 1
 (5,5) 1
```

## Preview Build Commands

To preview the build command details without executing the commands, use the `-n` option.

```
mex -n yprime.c
```

The output displays information specific to your platform and compiler.

## Display Detailed Build and Troubleshooting Information

To display the compile and link commands and other information useful for troubleshooting, use verbose mode.

```
mex -v -compatibleArrayDims yprime.c
```

The output displays information specific to your platform and compiler.

## Create and Link to Separate Object Files

You can link to object files that you compile separately from your source MEX-files.

The MEX-file example, `fulltosparse`, consists of two Fortran source files, `loadsparse.F` and `fulltosparse.F`. The `fulltosparse` file is the gateway routine (contains the `mexFunction` subroutine) and `loadsparse` contains the computational routine.

To run this example, you need a supported Fortran compiler installed on your system.

Copy the computational subroutine to your current folder.



```
copyfile(fullfile(matlabroot,'extern','examples','refbook',...
 'loadsparse.F'),'.','f');
```

Compile the subroutine and place the object file in a separate folder, c:\objfiles.

```
mkdir c:\objfiles
mex -largeArrayDims -c -outdir c:\objfiles loadsparse.F
```

Copy the gateway subroutine to your current folder. Compile and link with the loadsparse object file.

```
copyfile(fullfile(matlabroot,'extern','examples','refbook',...
 'fulltosparse.F'),'.','f');
mex -largeArrayDims fulltosparse.F c:\objfiles\loadsparse.obj
```

### Specify Path to Include File

Use the `-I` option to specify the path to include the MATLAB LAPACK library subroutines for handling complex number routines. To use these subroutines, your MEX-file must access the header file, `fort.h`.

Copy the `matrixDivideComplex.c` example to the current folder.

```
copyfile(fullfile(matlabroot,'extern','examples','refbook',...
 'matrixDivideComplex.c'),'.','f');
```

Create the `-I` argument by concatenating `'-I'` with the path to `fort.h` file.

```
ipath = ['-I' fullfile(matlabroot,'extern','examples','refbook')];
```

Create variables for the names and paths to the LAPACK library file and the file, `fort.c`, containing the complex number handling routines.

```
lapacklib = fullfile(matlabroot, ...
 'extern','lib',computer('arch'),'microsoft','libmwlapack.lib');
fortfile = fullfile(matlabroot,'extern','examples',...)
```

```
'refbook','fort.c');
```

Build the MEX-file.

```
mex('-v','-largeArrayDims',ipath, ...
 'matrixDivideComplex.c',fortfile,lapacklib)
```

## Specify Path to Library File

Build the `matrixDivide.c` example on a Windows platform.

Use the `-L` and `-l` options to specify the `libmwlapack.lib` library, located in the folder, `matlabroot\extern\lib\arch\microsoft`.

Copy the `matrixDivide.c` example to the current folder.

```
copyfile(fullfile(matlabroot,'extern','examples','refbook',...
 'matrixDivide.c'),'.','f');
```

Capture the value of `matlabroot`.

```
matlabroot
```

```
ans =
```

```
C:\Program Files\MATLAB\R2014a
```

Capture the value of `arch`.

```
arch
```

```
ans =
```

```
win64
```

To build the MEX-file, copy the values of `matlabroot` and `arch` into the `mex` command, as shown in the following statement.

```
mex -largeArrayDims '-LC:\Program Files\MATLAB\R2014a\extern\lib\win64\mi
```

You must use the ' characters because \Program Files in the path includes a space.

### Define Directive

Define the character to use between strings in a matrix.

The MATLAB example, `mxcreatecharmatrixfromstr.c`, uses a `#define` symbol, `SPACE_PADDING`, to determine what character to use between strings in a matrix. To set the value, build the MEX-file with the `-D` option.

Copy the `mxcreatecharmatrixfromstr.c` example to the current folder.

```
copyfile(fullfile(matlabroot,'extern','examples','mx',...
 'mxcreatecharmatrixfromstr.c'),'.','f');
```

Set the `SPACE_PADDING` directive to add a space between strings.

```
mex mxcreatecharmatrixfromstr.c -DSPACE_PADDING
```

### Override Default Compiler Switch Option

Build the `yprime.c` MEX-file by appending the value `-Wall` to the existing compiler flag. Because the value includes a space character, you must delineate the string; the character you use depends on the platform.

At the MATLAB prompt, use MATLAB single quotes (').

```
mex -v COMPFLAGS='$COMPFLAGS -Wall' yprime.c
```

At the Windows Command Prompt, use double quotes (").

```
mex -v COMPFLAGS="$COMPFLAGS -Wall" yprime.c
```

At the shell command line on Mac and Linux, use single quotes (').

```
mex -v CFLAGS='$CFLAGS -Wall' yprime.c
```

## Build Engine Application

Copy the `engwindemo.c` engine example to the current folder.

```
copyfile(fullfile(matlabroot,...
 'extern','examples','eng_mat','engwindemo.c'),'.','f');
```

```
mex -client engine engwindemo.c
```

Run the example.

```
!engwindemo
```

## Select C Compiler

```
mex -setup
```

MATLAB displays the options for your version and system based on the list of Supported and Compatible Compilers.

## Tips

- You can run `mex` from:
  - MATLAB Command Window
  - Windows system prompt
  - Mac Terminal
  - Linux shell

For command-line usage outside of MATLAB, the `mex` program is located in the folder specified by `[matlabroot 'bin']`.

- The MEX-file has a platform-dependent extension. You can place binary MEX-files for different platforms in the same folder.

Platform	Binary MEX-File Extension
Linux (64-bit)	<code>mexa64</code>
Apple Mac (64-bit)	<code>mexmaci64</code>

(Continued)

Platform	Binary MEX-File Extension
Microsoft Windows (32-bit)	mexw32
Windows (64-bit)	mexw64

To identify the MEX-file extension, use the `mexext` function.

- To use `mex` to build executable files for standalone MATLAB engine and MAT-file applications, use the `-client` engine option.

### See Also

[“C/C++ Matrix Library API”](#) | [“Fortran Matrix Library API”](#) | [mex.getCompilerConfigurations](#) | [dbmex](#) | [mexext](#) | [inmem](#) | [clear](#) | [loadlibrary](#) | [computer](#) | [prefdir](#) | [system](#) | [pcode](#)

### Related Examples

- [“Table of MEX-File Source Code Files”](#)

### Concepts

- [“Build MEX-File”](#)
- [“Changing Default Compiler”](#)

### External Web Sites

- [Supported and Compatible Compilers](#)

# mex.getCompilerConfigurations

---

**Purpose** Get compiler configuration information for building MEX-files

**Syntax**

```
cc = mex.getCompilerConfigurations
cc = mex.getCompilerConfigurations(lang)
cc = mex.getCompilerConfigurations(lang,list)
```

**Description** `cc = mex.getCompilerConfigurations` returns an object `cc` containing information about the default compiler configurations used by the `mex` command. There is one configuration for each supported language.

`cc = mex.getCompilerConfigurations(lang)` returns an array of objects for the given language, `lang`.

`cc = mex.getCompilerConfigurations(lang,list)` returns information about the set of configurations, `list`.

## Input Arguments

### **lang - Language**

'Any' (default) | 'C' | 'C++' | 'CPP' | 'Fortran'

Language, specified as one of these values.

'Any'	All supported languages. This is the default value.
'C'	All C compiler configurations, including C++ configurations.
'C++' or 'CPP'	All C++ compiler configurations.
'Fortran'	All Fortran compiler configurations.

### **list - Set of configurations**

'Selected' (default) | 'Installed' | 'Supported'

Set of configurations, specified as one of these values.

'Selected'	The default compiler for each language.
'Installed'	All supported compilers mex finds installed on your system.
'Supported'	All compilers supported in the current release.

## Output Arguments

### cc - Compiler information

mex.CompilerConfiguration object or array of objects

Compiler information, specified as a mex.CompilerConfiguration object or array of mex.CompilerConfiguration objects. The mex.CompilerConfiguration class contains the following read-only properties.

Property	Purpose
Name	Compiler name.
ShortName	Character string used to identify options file for the compiler.
Manufacturer	Name of the manufacturer of the compiler.
Language	Compiler language.
Version	(Windows platforms only) Version of the compiler.
Location	(Windows platforms only) Folder where compiler is installed.
Details	More read-only properties about the compiler configuration. These properties might differ across compilers, platforms, and releases of MATLAB.
LinkerName	Linker name.
LinkerVersion	(Windows platforms only) Version of the linker.

# mex.getCompilerConfigurations

---

Property	Purpose
MexOpt	Name and full path to options file.
Priority	The priority of this compiler.

## Examples

### Display Information for C Compiler

```
myCCompiler = mex.getCompilerConfigurations('C','Selected')
```

```
myCCompiler =
```

```
 CompilerConfiguration with properties:
```

```
 Name: 'Microsoft Visual C++ 2010 (C)'
 Manufacturer: 'Microsoft'
 Language: 'C'
 Version: '10.0'
 Location: 'c:\Program Files (x86)\Microsoft Visual Studio 10.0'
 ShortName: 'MSVC100'
 Priority: 'A'
 Details: [1x1 mex.CompilerConfigurationDetails]
 LinkerName: 'link'
 LinkerVersion: ''
 MexOpt: 'C:\Users\user\AppData\Roaming\MathWorks\MATLAB\R2014
```

MATLAB displays information depending on your architecture and your version of MATLAB.

### Display Number of Supported C Compilers

```
cLanguageCC = mex.getCompilerConfigurations('C','Supported');
length(cLanguageCC)
```

```
ans =
 10
```



The number of compilers for your version of MATLAB might be different.

## See Also

`mex`

## External Web Sites

- Supported and Compatible Compilers

# MException

---

<b>Purpose</b>	Capture error information
<b>Syntax</b>	<code>exception = MException(msgIdent, msgString, v<sub>1</sub>, v<sub>2</sub>, ..., v<sub>N</sub>)</code>
<b>Description</b>	<p><code>exception = MException(msgIdent, msgString, v<sub>1</sub>, v<sub>2</sub>, ..., v<sub>N</sub>)</code> captures information about a specific error and stores it in MException object, <i>exception</i>. Information stored in the object includes a message identifier <i>msgIdent</i> and an error message string <i>msgString</i>. Optional arguments <i>v<sub>1</sub></i>, <i>v<sub>2</sub></i>, ... represent text or numeric values that replace conversion specifiers in <i>msgString</i> at run time.</p> <p>Message identifier <i>msgIdent</i> is a character string composed of at least two substrings, the <i>component</i> and the <i>mnemonic</i>, separated by a colon (e.g., <i>component:mnemonic</i>). The purpose of the identifier is to better identify the source of the error. See the documentation on “Message Identifiers” for more information.</p> <p>Message string <i>msgString</i> is a character string that informs the user about the cause of the error and can also suggest how to correct the faulty condition. The <i>msgString</i> string can include escape sequences such as <code>\t</code> or <code>\n</code>, as well as any of the format specifiers supported by the <code>sprintf</code> function (such as <code>%s</code> or <code>%d</code>). Additional arguments <i>v<sub>1</sub></i>, <i>v<sub>2</sub></i>, ..., <i>v<sub>N</sub></i> provide values that correspond to and replace the conversion specifiers.</p> <p>For example, if <i>msgString</i> is “Error on line %d, command %s”, then <i>v<sub>1</sub></i> is the line number at which the error was detected, and <i>v<sub>2</sub></i> is the command that failed. See “Formatting Strings” in the MATLAB Programming Fundamentals documentation for more detailed information on using string formatting commands.</p> <p>The <i>exception</i> output is an object of the MException class. MException is the constructor for this class. In addition to calling the constructor directly, you can also create an object of MException with any of the following functions: <code>error</code> and <code>assert</code>. See the documentation and figure in the section “The MException Class” for more information on this class.</p>

## Properties

The MException object has four properties: `identifier`, `message`, `stack`, and `cause`. Click any of the links below to find out more about MException properties:

Property	Description
<code>identifier</code>	Identifies the error.
<code>message</code>	Formatted error message that is displayed.
<code>stack</code>	Structure containing stack trace information such as file name, function name, and line number where the MException was thrown.
<code>cause</code>	Cell array of MException that caused this exception to be created.

## Methods

The MException class has the following methods. Click any of the links below to find out more about MException methods:

Method	Description
<code>addCause</code>	Appends an MException to the <code>cause</code> field of another MException.
<code>eq</code>	Tests scalar MException objects for equality.
<code>getReport</code>	Returns a formatted message string that uses the same format as errors thrown by internal MATLAB code.
<code>isequal</code>	Tests scalar MException objects for equality.
<code>last</code>	Returns an MException object for the most recently thrown exception.
<code>ne</code>	Tests scalar MException objects for inequality.

# MException

---

Method	Description
rethrow	Reissues an exception that has been caught, causing the program to stop.
throw	Issues an exception from the currently running function.
throwAsCaller	Issues an exception from the currently running function, also omitting the current stack frame from the <code>stack</code> field of the <code>MException</code> .

## Tips

Valid escape sequences for the `msgString` argument are `\b`, `\f`, `\n`, `\r`, `\t`, and `\x` or `\` when followed by a valid hexadecimal or octal number, respectively. Following a backslash in the `msgString` with any other character causes MATLAB to issue a warning. Conversion specifiers are similar to those used in the C programming language and in the `sprintf` function.

All string input arguments must be enclosed in single quotation marks.

## Examples

### Example 1 – Formatted Messages

If your message string requires formatting specifications like those used with the `sprintf` function, you can use this syntax to compose the error message string:

```
exception = MException(msgIdent, msgString, v1, v2, ...)
```

For example,

```
exception = MException('AcctError:Incomplete', ...
 'Field ''%.%.s'' is not defined.', ...
 'Accounts', 'ClientName');
```

```
exception.message
ans =
 Field 'Accounts.ClientName' is not defined.
```

## Example 2

The catch block in this example checks to see if the specified file could not be found. If this is the case, the program allows for the possibility that a common variation of the filename extension (e.g., jpeg instead of jpg) was used by retrying the operation with a modified extension. This is done using a try/catch statement that is nested within the original try/catch.

```
function d_in = read_image(filename)
[path name ext] = fileparts(filename);
try
 fid = fopen(filename, 'r');
 d_in = fread(fid);
catch exception

 % Did the read fail because the file could not be found?
 if ~exist(filename, 'file')

 % Yes. Try modifying the filename extension.
 switch ext
 case '.jpg' % Change jpg to jpeg
 altFilename = strrep(filename, '.jpg', '.jpeg')
 case '.jpeg' % Change jpeg to jpg
 altFilename = strrep(filename, '.jpeg', '.jpg')
 case '.tif' % Change tif to tiff
 altFilename = strrep(filename, '.tif', '.tiff')
 case '.tiff' % Change tiff to tif
 altFilename = strrep(filename, '.tiff', '.tif')
 otherwise
 rethrow(exception);
 end

 % Try again, with modified filename.
 try
 fid = fopen(altFilename, 'r');
 d_in = fread(fid);
 catch
```

```
 rethrow(exception)
 end
end
end
```

### Example 3 – Nested try/catch

This example attempts to open a file in a folder that is not on the MATLAB path. It uses a nested try-catch block to give the user the opportunity to extend the path. If the file still cannot be found, the program issues an exception with the first error appended to the second:

```
function data = read_it(filename);
try
 % Attempt to open and read from a file.
 fid = fopen(filename, 'r');
 data = fread(fid);
catch exception1
 % If the error was caused by an invalid file ID, try
 % reading from another location.
 if strcmp(exception1.identifier, 'MATLAB:FileIO:InvalidFid')
 msg = sprintf(...
 '\nCannot open file %s. Try another location? ', ...
 filename);
 reply = input(msg, 's')
 if reply(1) == 'y'
 newFolder = input('Enter folder name: ', 's');
 else
 throw(exception1);
 end
 oldpath = addpath(newFolder);
 try
 fid = fopen(filename, 'r');
 data = fread(fid);
 catch exception2
 exception3 = addCause(exception2, exception1)
 path(oldpath);
 throw(exception3);
 end
 end
end
```

```
 end
 path(oldpath);
 end
end
fclose(fid);
```

If you run this function in a try-catch block at the command line, you can look at the MException object by assigning it to a variable (e) with the catch command.

## See Also

```
dbstack | ne(MException) | isequal(MException) |
eq(MException) | getReport(MException) | last(MException)
| addCause(MException) | throwAsCaller(MException) |
rethrow(MException) | throw(MException) | assert | error | try,
catch
```

## Related Examples

- “The MException Class”

# mexext

---

**Purpose** Binary MEX-file-name extension

**Syntax**  
`ext = mexext`  
`extlist = mexext('all')`

**Description** `ext = mexext` returns the file-name extension for the current platform.

`extlist = mexext('all')` returns the extensions for all platforms.

**Output Arguments**  
**ext - File-name extension**  
`mexa64` | `mexmaci64` | `mexw32` | `mexw64`

File-name extension for MEX-file, returned as one of these values.

Platform	Binary MEX-File Extension
Linux (64-bit)	<code>mexa64</code>
Apple Mac (64-bit)	<code>mexmaci64</code>
Microsoft Windows (32-bit)	<code>mexw32</code>
Windows (64-bit)	<code>mexw64</code>

**extlist - All file-name extensions**

structure

All file-name extensions, returned as a structure with these fields:

**arch - Platform**

string

Platform, specified as a string. The name of the platform is the output of the `computer('arch')` command.

**ext - File extension**

string



File extension, specified as a string.

## Examples

### Display File Extension for Your Computer

Find the MEX-file extension for the system you are currently working on.

```
ext = mexext
```

```
ext =
 mexw32
```

Your results reflect your system.

### Find File Extension for Specific Platform

Find the MEX-file extension for the Apple Macintosh systems.

Get the list for supported platforms.

```
extlist = mexext('all');
```

The mex function identifies a platform by its arch value, which is the output of the computer('arch') command. For Macintosh platforms, the value is maci64.

Search the arch field in the results, extlist, for 'maci64', and display the corresponding ext field.

```
for k=1:length(extlist)
 if strcmp(extlist(k).arch, 'maci64')
 disp(sprintf('Arch: %s Ext: %s', ...
 extlist(k).arch, extlist(k).ext))
 end, end
```

```
Arch: maci64 Ext: mexmaci64
```

The file extension is mexmaci64.

## Tips

- To use the MEX-file-name extension in makefiles or scripts outside MATLAB, type one of the following from the system command prompt. The script is located in the *matlabroot*\bin folder.
  - `mexext.bat`—Windows platform.
  - `mexext.sh`—UNIX platform.

For example, the following commands are in a GNU® makefile.

```
ext = $(shell mexext)
yprime.$(ext) : yprime.c
 mex yprime.c
```

- MATLAB continues to execute a MEX-file with a `.dll` extension, but future versions of MATLAB will not support this extension.

## See Also

`mex` | `computer`

**Purpose** File name of currently running function

**Syntax**

```
mfilename
p = mfilename('fullpath')
c = mfilename('class')
```

**Description** `mfilename` returns a string containing the file name of the most recently invoked function. When called from within the file, it returns the name of that file. This allows a function to determine its name, even if the file name has been changed.

`p = mfilename('fullpath')` returns the full path and name of the file in which the call occurs, not including the filename extension.

`c = mfilename('class')` in a method, returns the class of the method, not including the leading @ sign. If called from a nonmethod, it yields the empty string.

**Tips** If `mfilename` is called with any argument other than the above two, it behaves as if it were called with no argument.

When called from the command line, `mfilename` returns an empty string.

To get the names of the callers of a MATLAB function file, use `dbstack` with an output argument.

**See Also** `dbstack` | `function` | `nargin` | `nargout` | `inputname`

# FTP.mget

---

<b>Purpose</b>	Download files from FTP server
<b>Syntax</b>	<code>mget(ftpobj, contents)</code> <code>mget(ftpobj, contents, target)</code>
<b>Description</b>	<code>mget(ftpobj, contents)</code> retrieves the file or folder specified by <code>contents</code> from an FTP server into the MATLAB current folder. <code>mget(ftpobj, contents, target)</code> retrieves the file or folder into the local folder specified by <code>target</code> , which includes an absolute or relative path.
<b>Input Arguments</b>	<b>ftpobj</b> FTP object created by <code>ftp</code> . <b>contents</b> String enclosed in single quotation marks that specifies either a file name or a folder name. Can include a wildcard character (*). <b>target</b> String enclosed in single quotation marks that specifies the absolute or relative path of the local folder to contain the downloaded contents.
<b>Examples</b>	Connect to an FTP server and retrieve the file README into the current MATLAB folder: <pre>mw = ftp('ftp.mathworks.com'); mget(mw, 'README'); close(mw);</pre>
<b>See Also</b>	<code>cd</code>   <code>ftp</code>   <code>mput</code>

**Purpose**

Smallest elements in array

**Syntax**

```
C = min(A)
C = min(A,[],dim)
[C,I] = min(...)
```

```
C = min(A,B)
```

**Description**

`C = min(A)` returns the smallest elements along different dimensions of an array.

If `A` is a vector, `min(A)` returns the smallest element in `A`.

If `A` is a matrix, `min(A)` treats the columns of `A` as vectors, returning a row vector containing the minimum element from each column.

If `A` is a multidimensional array, `min` operates along the first nonsingleton dimension.

`C = min(A,[],dim)` returns the smallest elements along the dimension of `A` specified by scalar `dim`. For example, `min(A,[],1)` produces the minimum values along the first dimension of `A`.

`[C,I] = min(...)` finds the indices of the minimum values of `A`, and returns them in output vector `I`. If there are several identical minimum values, the index of the first one found is returned.

`C = min(A,B)` returns an array the same size as `A` and `B` with the smallest elements taken from `A` or `B`. The dimensions of `A` and `B` must match, or they may be scalar.

**Examples**

Return the minimum of a 2-by-3 matrix from each column:

```
X = [2 8 4; 7 3 9];
min(X,[],1)
ans =
```

# min

---

```
2 3 4
```

Return the minimum from each row:

```
min(X,[],2)
ans =
```

```
2
3
```

Compare each element of X to a scalar:

```
min(X,5)
ans =
```

```
2 5 4
5 3 5
```

## Tips

For complex input A, `min` returns the complex number with the smallest complex modulus (magnitude), computed with `min(abs(A))`. Then computes the smallest phase angle with `min(angle(x))`, if necessary.

The `min` function ignores NaNs.

## See Also

[max](#) | [mean](#) | [median](#) | [sort](#)

**Purpose** Minimize size of Automation server window

**Syntax** **IDL Method Signature**

```
HRESULT MinimizeCommandWindow(void)
```

**Microsoft Visual Basic Client**

```
MinimizeCommandWindow
```

**MATLAB Client**

```
h.MinimizeCommandWindow
MinimizeCommandWindow(h)
```

**Description** h.MinimizeCommandWindow minimizes the window for the server attached to handle h, and makes it inactive.

MinimizeCommandWindow(h) is an alternate syntax.

If the server window was already in a minimized state, MinimizeCommandWindow does nothing.

**Examples** From a Visual Basic .NET client, modify the size of the command window in a MATLAB Automation server:

```
Dim Matlab As Object
```

```
Matlab = CreateObject("matlab.application")
Matlab.MinimizeCommandWindow
```

```
'Now return the server window to its former state on
'the desktop and make it the currently active window.
```

```
Matlab.MaximizeCommandWindow
```

**See Also** MaximizeCommandWindow

# minres

---

## Purpose

Minimum residual method

## Syntax

```
x = minres(A,b)
minres(A,b,tol)
minres(A,b,tol,maxit)
minres(A,b,tol,maxit,M)
minres(A,b,tol,maxit,M1,M2)
minres(A,b,tol,maxit,M1,M2,x0)
[x,flag] = minres(A,b,...)
[x,flag,relres] = minres(A,b,...)
[x,flag,relres,iter] = minres(A,b,...)
[x,flag,relres,iter,resvec] = minres(A,b,...)
[x,flag,relres,iter,resvec,resveccg] = minres(A,b,...)
```

## Description

`x = minres(A,b)` attempts to find a minimum norm residual solution  $x$  to the system of linear equations  $A*x=b$ . The  $n$ -by- $n$  coefficient matrix  $A$  must be symmetric but need not be positive definite. It should be large and sparse. The column vector  $b$  must have length  $n$ . You can specify  $A$  as a function handle, `afun`, such that `afun(x)` returns  $A*x$ .

“Parameterizing Functions” explains how to provide additional parameters to the function `afun`, as well as the preconditioner function `mfun` described below, if necessary.

If `minres` converges, a message to that effect is displayed. If `minres` fails to converge after the maximum number of iterations or halts for any reason, a warning message is printed displaying the relative residual norm  $\|b-A*x\|/\|b\|$  and the iteration number at which the method stopped or failed.

`minres(A,b,tol)` specifies the tolerance of the method. If `tol` is `[]`, then `minres` uses the default,  $1e-6$ .

`minres(A,b,tol,maxit)` specifies the maximum number of iterations. If `maxit` is `[]`, then `minres` uses the default,  $\min(n,20)$ .

`minres(A,b,tol,maxit,M)` and `minres(A,b,tol,maxit,M1,M2)` use symmetric positive definite preconditioner  $M$  or  $M = M1*M2$  and effectively solve the system  $\text{inv}(\text{sqrt}(M))*A*\text{inv}(\text{sqrt}(M))*y =$



$\text{inv}(\text{sqrt}(M))*b$  for  $y$  and then return  $x = \text{inv}(\text{sqrt}(M))*y$ . If  $M$  is  $[]$  then `minres` applies no preconditioner.  $M$  can be a function handle `mfun`, such that `mfun(x)` returns  $M \backslash x$ .

`minres(A,b,tol,maxit,M1,M2,x0)` specifies the initial guess. If  $x_0$  is  $[]$ , then `minres` uses the default, an all-zero vector.

`[x,flag] = minres(A,b,...)` also returns a convergence flag.

Flag	Convergence
0	minres converged to the desired tolerance <code>tol</code> within <code>maxit</code> iterations.
1	minres iterated <code>maxit</code> times but did not converge.
2	Preconditioner $M$ was ill-conditioned.
3	minres stagnated. (Two consecutive iterates were the same.)
4	One of the scalar quantities calculated during <code>minres</code> became too small or too large to continue computing.

Whenever `flag` is not 0, the solution  $x$  returned is that with minimal norm residual computed over all the iterations. No messages are displayed if the `flag` output is specified.

`[x,flag,relres] = minres(A,b,...)` also returns the relative residual  $\text{norm}(b-A*x)/\text{norm}(b)$ . If `flag` is 0, `relres`  $\leq$  `tol`.

`[x,flag,relres,iter] = minres(A,b,...)` also returns the iteration number at which  $x$  was computed, where  $0 \leq \text{iter} \leq \text{maxit}$ .

`[x,flag,relres,iter,resvec] = minres(A,b,...)` also returns a vector of estimates of the `minres` residual norms at each iteration, including  $\text{norm}(b-A*x_0)$ .

`[x,flag,relres,iter,resvec,resvecg] = minres(A,b,...)` also returns a vector of estimates of the Conjugate Gradients residual norms at each iteration.

## Examples

### Using minres with a Matrix Input

```
n = 100; on = ones(n,1);
A = spdiags([-2*on 4*on -2*on],-1:1,n,n);
b = sum(A,2);
tol = 1e-10;
maxit = 50;
M1 = spdiags(4*on,0,n,n);

x = minres(A,b,tol,maxit,M1);
minres converged at iteration 49 to a solution with relative
residual 4.7e-014
```

### Using minres with a Function Handle

This example replaces the matrix A in the previous example with a handle to a matrix-vector product function `afun`. The example is contained in a file `run_minres` that

- Calls `minres` with the function handle `@afun` as its first argument.
- Contains `afun` as a nested function, so that all variables in `run_minres` are available to `afun`.

The following shows the code for `run_minres`:

```
function x1 = run_minres
n = 100;
on = ones(n,1);
A = spdiags([-2*on 4*on -2*on],-1:1,n,n);
b = sum(A,2);
tol = 1e-10;
maxit = 50;
M = spdiags(4*on,0,n,n);
x1 = minres(@afun,b,tol,maxit,M);

function y = afun(x)
y = 4 * x;
y(2:n) = y(2:n) - 2 * x(1:n-1);
y(1:n-1) = y(1:n-1) - 2 * x(2:n);
```

```

 end
 end

```

When you enter

```
x1=run_minres;
```

MATLAB software displays the message

```
minres converged at iteration 49 to a solution with relative
residual 4.7e-014
```

### Using minres instead of pcg

Use a symmetric indefinite matrix that fails with pcg.

```
A = diag([20:-1:1, -1:-1:-20]);
b = sum(A,2); % The true solution is the vector of all ones.
x = pcg(A,b); % Errors out at the first iteration.
```

displays the following message:

```
pcg stopped at iteration 1 without converging to the desired
tolerance 1e-006 because a scalar quantity became too small or
too large to continue computing.
The iterate returned (number 0) has relative residual 1
```

However, minres can handle the indefinite matrix A.

```
x = minres(A,b,1e-6,40);
minres converged at iteration 39 to a solution with relative
residual 1.3e-007
```

## References

- [1] Barrett, R., M. Berry, T. F. Chan, et al., *Templates for the Solution of Linear Systems: Building Blocks for Iterative Methods*, SIAM, Philadelphia, 1994.
- [2] Paige, C. C. and M. A. Saunders, "Solution of Sparse Indefinite Systems of Linear Equations." *SIAM J. Numer. Anal.*, Vol.12, 1975, pp. 617-629.

# minres

---

## **See Also**

`bicg` | `bicgstab` | `cgs` | `ichol` | `function_handle` | `gmres` | `lsqr` |  
`pcg` | `qmr` | `symmlq` | `mldivide`

<b>Purpose</b>	Subtraction
<b>Syntax</b>	$C = A - B$ <code>C = minus(A,B)</code>
<b>Description</b>	<p><math>C = A - B</math> subtracts array B from array A and returns the result in C.</p> <p><code>C = minus(A,B)</code> is an alternate way to execute <math>A - B</math>, but is rarely used. It enables operator overloading for classes.</p>
<b>Input Arguments</b>	<p><b>A - Input array</b> scalar   vector   matrix   multidimensional array</p> <p>Input array, specified as a scalar, vector, matrix, or multidimensional array. Inputs A and B must be the same size unless one is a scalar. You can add a scalar value to any other value.</p> <p><b>Data Types</b> single   double   int8   int16   int32   int64   uint8   uint16   uint32   uint64   logical   char <b>Complex Number Support:</b> Yes</p> <p><b>B - Input array</b> scalar   vector   matrix   multidimensional array</p> <p>Input array, specified as a scalar, vector, matrix, or multidimensional array. Inputs A and B must be the same size unless one is a scalar. You can add a scalar value to any other value.</p> <p><b>Data Types</b> single   double   int8   int16   int32   int64   uint8   uint16   uint32   uint64   logical   char <b>Complex Number Support:</b> Yes</p>
<b>Examples</b>	<p><b>Subtract Scalar from Array</b></p> <p>Create an array, A, and subtract a scalar value from it.</p>

## minus, -

---

```
A = [2 1; 3 5];
C = A - 2
```

```
C =
```

```
 0 -1
 1 3
```

The scalar is subtracted from each entry of A.

### Subtract Two Arrays

Create two arrays, A and B, and subtract the second, B, from the first, A.

```
A = [1 0; 2 4];
B = [5 9; 2 1];
C = A - B
```

```
C =
```

```
 -4 -9
 0 3
```

The elements of B are subtracted from the corresponding elements of A.

Use the syntax `-C` to negate the elements of C.

```
-C
```

```
ans =
```

```
 4 9
 0 -3
```

### See Also

`plus` | `diff` | `uminus`

**Purpose** Determine if function is locked in memory

**Syntax** `mislocked`  
`mislocked(fun)`

**Description** `mislocked` by itself returns logical 1 (`true`) if the currently running function is locked in memory, and logical 0 (`false`) otherwise. Functions that are locked cannot be removed with the `clear` function unless you first unlock them using the `munlock` function. You can use locking on functions that reside in MATLAB `.m` files or `.mex` files.

`mislocked(fun)` returns logical 1 (`true`) if the function named *fun* is locked in memory, and logical 0 (`false`) otherwise.

**See Also** `mlock` | `munlock` | `inmem`

# mkdir

---

## Purpose

Make new folder

## Syntax

```
mkdir('folderName')
mkdir('parentFolder','folderName')
status = mkdir(___)
[status,message,messageid] = mkdir(___)
```

## Description

`mkdir('folderName')` creates the folder `folderName`, where `folderName` can be an absolute or a relative path.

`mkdir('parentFolder','folderName')` creates the folder `folderName` in `parentFolder`, where `parentFolder` is an absolute or relative path. If `parentFolder` does not exist, MATLAB attempts to create it. See the Tips section.

`status = mkdir( ___ )` creates the specified folder. When the operation is successful, it returns a `status` of logical 1. When the operation is unsuccessful, it returns logical 0.

`[status,message,messageid] = mkdir( ___ )` creates the specified folder, and returns the `status`, message string, and MATLAB message ID. The value given to `status` is logical 1 for success, and logical 0 for error.

## Tips

If an argument specifies a path that includes one or more nonexistent folders, MATLAB attempts to create the nonexistent folder. For example, for

```
mkdir('myFolder\folder1\folder2\targetFolder')
```

if `folder1` does not exist, MATLAB creates `folder1`, creates `folder2` within `folder1`, and creates `targetFolder` within `folder2`.

## Examples

### Creating a Subfolder in the Current Folder

Create a subfolder called `newdir` in the current folder:

```
mkdir('newdir')
```



### Creating a Subfolder in the Specified Parent Folder

Create a subfolder called `newFolder` in the folder `testdata`, using a relative path, where `newFolder` is at the same level as the current folder:

```
mkdir('../testdata','newFolder')
```

### Returning Status When Creating a Folder

In this example, the first attempt to create `newFolder` succeeds, returning a status of 1, and no error or warning message or message identifier:

```
[s, mess, messid] = mkdir('../testdata', 'newFolder')
s =
 1
mess =
 ''
messid =
 ''
```

Attempt to create the same folder again. `mkdir` again returns a success status, and also a warning and message identifier informing you that the folder exists:

```
[s,mess,messid] = mkdir('../testdata','newFolder')
s =
 1
mess =
 Directory "newFolder" already exists.
messid =
 MATLAB:MKDIR:DirectoryExists
```

### See Also

`copyfile` | `cd` | `dir` | `ls` | `movefile` | `rmdir`

### How To

- “Manage Files and Folders”

# FTP.mkdir

---

**Purpose** Create folder on FTP server

**Syntax** `mkdir(ftpobj, folder)`

**Description** `mkdir(ftpobj, folder)` creates the specified folder on the FTP server associated with `ftpobj`.

**Input Arguments**

**ftpobj**  
FTP object created by `ftp`.

**folder**  
String enclosed in single quotation marks that specifies a path relative to the current folder on the FTP server.

**Examples** Suppose that a hypothetical host, `ftp.testsite.com`, contains a folder named `testfolder`. Connect to the server and add a subfolder:

```
test=ftp('ftp.testsite.com');
mkdir(test, 'testfolder/newfolder');
close(test);
```

**See Also** `dir` | `ftp` | `rmdir`

**Purpose** Make piecewise polynomial

**Syntax**  
`pp = mkpp(breaks,coefs)`  
`pp = mkpp(breaks,coefs,d)`

**Description** `pp = mkpp(breaks,coefs)` builds a piecewise polynomial `pp` from its `breaks` and coefficients. `breaks` is a vector of length `L+1` with strictly increasing elements which represent the start and end of each of `L` intervals. `coefs` is an `L`-by-`k` matrix with each row `coefs(i,:)` containing the coefficients of the terms, from highest to lowest exponent, of the order `k` polynomial on the interval `[breaks(i),breaks(i+1)]`.

`pp = mkpp(breaks,coefs,d)` indicates that the piecewise polynomial `pp` is `d`-vector valued, i.e., the value of each of its coefficients is a vector of length `d`. `breaks` is an increasing vector of length `L+1`. `coefs` is a `d`-by-`L`-by-`k` array with `coefs(r,i,:)` containing the `k` coefficients of the `i`th polynomial piece of the `r`th component of the piecewise polynomial.

Use `ppval` to evaluate the piecewise polynomial at specific points. Use `unmkpp` to extract details of the piecewise polynomial.

**Note.** The *order* of a polynomial tells you the number of coefficients used in its description. A *k*th order polynomial has the form

$$c_1x^{k-1} + c_2x^{k-2} + \dots + c_{k-1}x + c_k$$

It has *k* coefficients, some of which can be 0, and maximum exponent *k* - 1. So the order of a polynomial is usually one greater than its degree. For example, a cubic polynomial is of order 4.

## Examples **Construct and Plot Piecewise Polynomial**

The first plot shows the quadratic polynomial

$$1 - \left(\frac{x}{2} - 1\right)^2 = \frac{-x^2}{4} + x$$

shifted to the interval `[-8,-4]`. The second plot shows its negative

$$\left(\frac{x}{2} - 1\right)^2 - 1 = \frac{x^2}{4} - x$$

but shifted to the interval [-4,0].

The last plot shows a piecewise polynomial constructed by alternating these two quadratic pieces over four intervals. It also shows its first derivative, which was constructed after breaking the piecewise polynomial apart using `unmkpp`.

```
subplot(2,2,1)
cc = [-1/4 1 0];
pp1 = mkpp([-8 -4],cc);
xx1 = -8:0.1:-4;
plot(xx1,ppval(pp1,xx1),'k-')

subplot(2,2,2)
pp2 = mkpp([-4 0],-cc);
xx2 = -4:0.1:0;
plot(xx2,ppval(pp2,xx2),'k-')

subplot(2,1,2)
pp = mkpp([-8 -4 0 4 8],[cc;-cc;cc;-cc]);
xx = -8:0.1:8;
plot(xx,ppval(pp,xx),'k-')
[breaks,coefs,l,k,d] = unmkpp(pp);
dpp = mkpp(breaks,repmat(k-1:-1:1,d*1,1).*coefs(:,1:k-1),d);
hold on, plot(xx,ppval(dpp,xx),'r-'), hold off
```

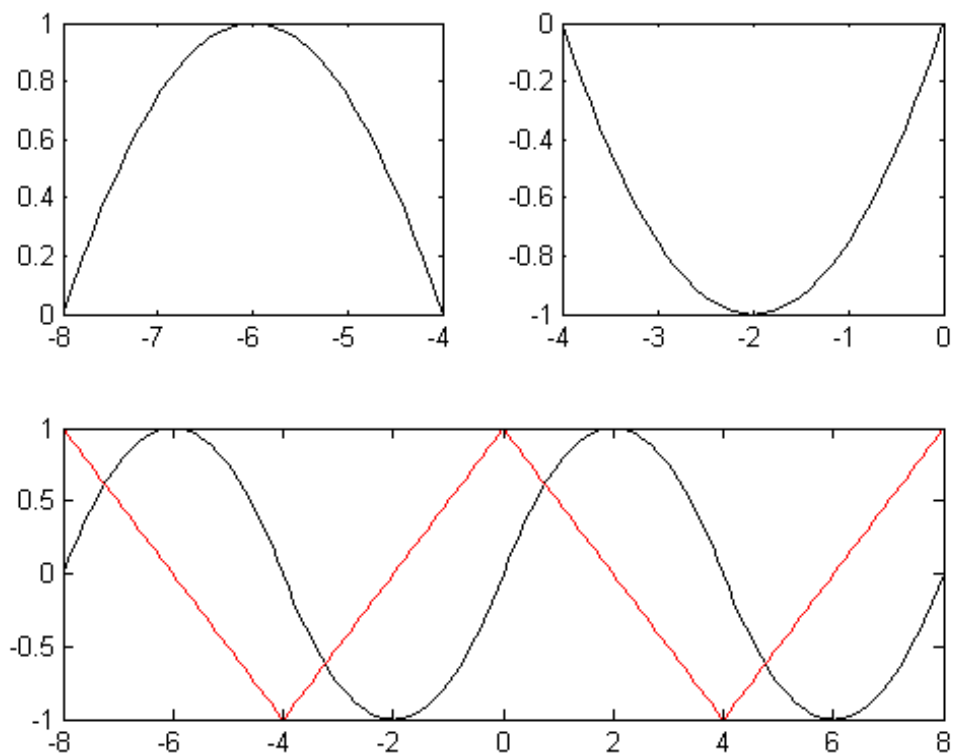

**See Also** [ppval](#) | [spline](#) | [unmkpp](#)

# mldivide, \

---

**Purpose** Solve systems of linear equations  $Ax = B$  for  $x$

**Syntax**  
 $x = A \setminus B$   
 $x = \text{mldivide}(A,B)$

**Description**  $x = A \setminus B$  solves the system of linear equations  $A * x = B$ . The matrices  $A$  and  $B$  must have the same number of rows. MATLAB displays a warning message if  $A$  is badly scaled or nearly singular, but performs the calculation regardless.

- If  $A$  is a scalar, then  $A \setminus B$  is equivalent to  $A . \setminus B$ .
- If  $A$  is a square  $n$ -by- $n$  matrix and  $B$  is a matrix with  $n$  rows, then  $x = A \setminus B$  is a solution to the equation  $A * x = B$ , if it exists.
- If  $A$  is a rectangular  $m$ -by- $n$  matrix with  $m \neq n$ , and  $B$  is a matrix with  $m$  rows, then  $A \setminus B$  returns a least-squares solution to the system of equations  $A * x = B$ .

$x = \text{mldivide}(A,B)$  is an alternative way to execute  $x = A \setminus B$ , but is rarely used. It enables operator overloading for classes.

## Input Arguments

**A - Coefficient matrix**  
vector | full matrix | sparse matrix

Coefficient matrix, specified as a vector, full matrix, or sparse matrix. If  $A$  has  $m$  rows, then  $B$  must have  $m$  rows.

**Data Types**  
single | double  
**Complex Number Support:** Yes

**B - Right-hand side**  
vector | full matrix | sparse matrix

Right-hand side, specified as a vector, full matrix, or sparse matrix. If  $B$  has  $m$  rows, then  $A$  must have  $m$  rows.

**Data Types**

single | double

**Complex Number Support:** Yes**Output Arguments****x - Solution**

vector | full matrix | sparse matrix

Solution, returned as a vector, full matrix, or sparse matrix. If A is an m-by-n matrix and B is an m-by-p matrix, then x is an n-by-p matrix, including the case when p==1.

If A has full storage, x is also full. If A is sparse, then x has the same storage as B.

**Examples****System of Equations**

Solve a simple system of linear equations,  $A*x = B$ .

```
A = magic(3);
B = [15; 15; 15];
x = A\B
```

```
x =
```

```
 1.0000
 1.0000
 1.0000
```

**Linear System with Singular Matrix**

Solve a linear system of equations  $A*x = b$  involving a singular matrix, A.

```
A = magic(4);
b = [34; 34; 34; 34];
x = A\b
```

```
Warning: Matrix is close to singular or badly scaled. Results may be
1.306145e-17.
```

# mldivide, \

---

```
x =

 1.5000
 2.5000
 -0.5000
 0.5000
```

When `rcond` is between 0 and `eps`, MATLAB issues a nearly singular warning, but proceeds with the calculation. When working with ill-conditioned matrices, an unreliable solution can result even though the residual ( $\mathbf{b} - \mathbf{A}^*\mathbf{x}$ ) is relatively small. In this particular example, the norm of the residual is zero, and an exact solution is obtained, although `rcond` is small.

When `rcond` is equal to 0, the singular warning appears.

```
A = [1 0; 0 0];
b = [1; 1];
x = A\b
```

```
Warning: Matrix is singular to working precision.
```

```
x =

 1
 Inf
```

In this case, division by zero leads to computations with `Inf` and/or `NaN`, making the computed result unreliable.

## Least-Squares Solution of Underdetermined System

Solve a system of linear equations,  $\mathbf{A}^*\mathbf{x} = \mathbf{b}$ .

```
A = [1 2 0; 0 4 3];
b = [8; 18];
x = A\b
```



```
ans =
 0
 4.0000
 0.6667
```

### Linear System with Sparse Matrix

Solve a simple system of linear equations using sparse matrices.

Consider the matrix equation  $A*x = B$ .

```
A = sparse([0 2 0 1 0; 4 -1 -1 0 0; 0 0 0 3 -6; -2 0 0 0 2; 0 0 4 2 0]);
B = sparse([8; -1; -18; 8; 20]);
x = A\B
```

```
x =
 (1,1) 1.0000
 (2,1) 2.0000
 (3,1) 3.0000
 (4,1) 4.0000
 (5,1) 5.0000
```

### Tips

- If  $A$  is a square matrix,  $A\backslash B$  is roughly equal to  $\text{inv}(A)*B$ , but MATLAB processes  $A\backslash B$  differently and more robustly.
- If the rank of  $A$  is less than the number of columns in  $A$ , then  $x = A\backslash B$  is not necessarily the minimum norm solution. The more computationally expensive  $x = \text{pinv}(A)*B$  computes the minimum norm least-squares solution.
- For full singular inputs, you can compute the least-squares solution using the function `linsolve`.

### Algorithms

The versatility of `mldivide` in solving linear systems stems from its ability to take advantage of symmetries in the problem by dispatching to an appropriate solver. This approach aims to minimize computation

time. The first distinction the function makes is between *full* (also called “*dense*”) and *sparse* input arrays.

## **Algorithm for Full Inputs**

The flow chart below shows the algorithm path when inputs A and B are **full**.

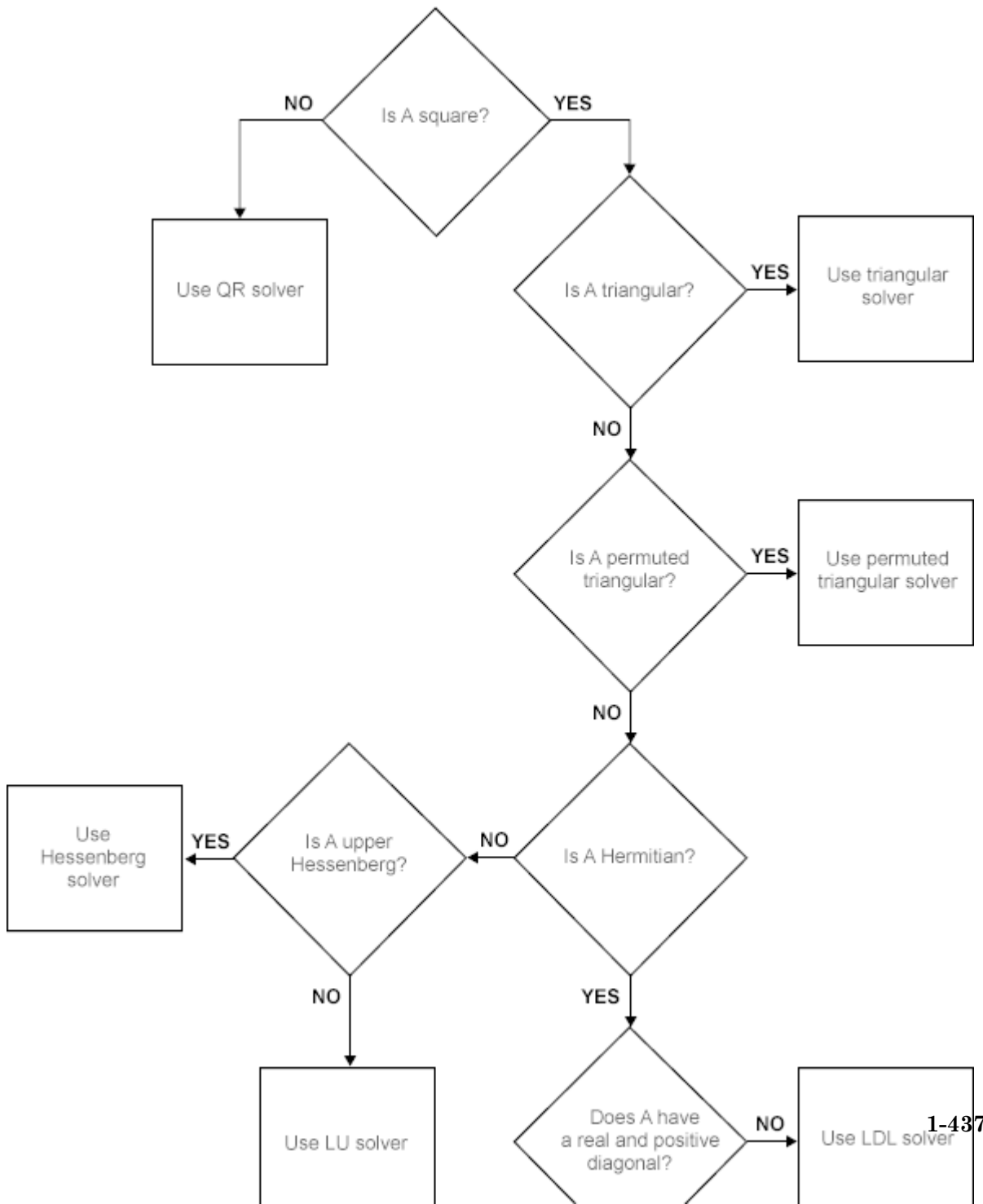

## **Algorithm for Sparse Inputs**

If  $A$  is full and  $B$  is sparse then `mldivide` converts  $B$  to a full matrix and uses the full algorithm path (above) to compute a solution with full storage. If  $A$  is sparse, the storage of the solution  $x$  is the same as that of  $B$  and `mldivide` follows the algorithm path for **sparse** inputs, shown below.

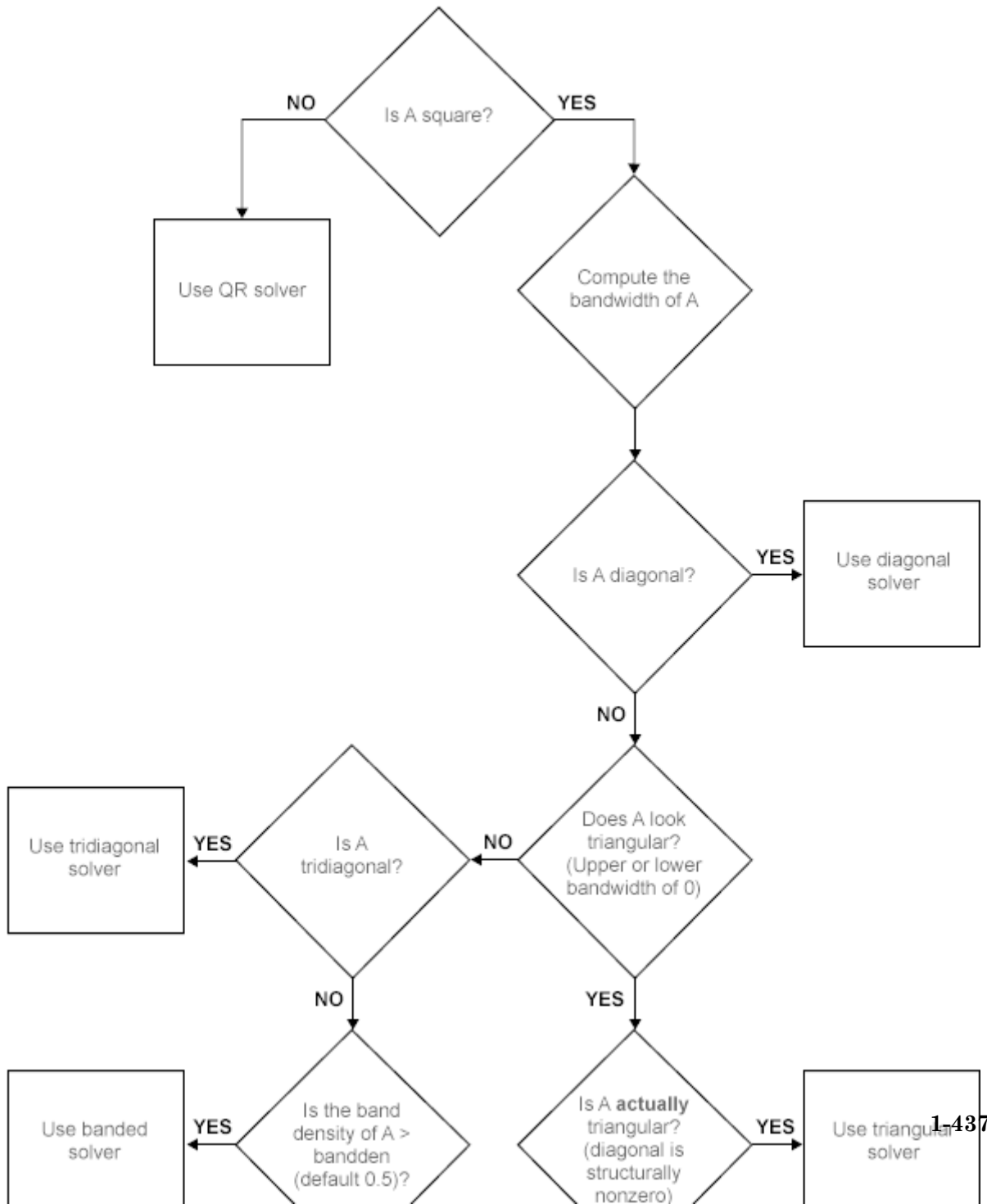

# **mldivide, \**

---

## **See Also**

`mrdivide` | `ldivide` | `rdivide` | `inv` | `pinv` | `chol` | `lu` | `qr` | `linsolve` | `ldl`

## **Concepts**

- “Systems of Linear Equations”
- “Implementing Operators for Your Class”

**Purpose** Solve systems of linear equations  $xA = B$  for  $x$

**Syntax**  
 $x = B/A$   
 $x = \text{mrdivide}(B,A)$

**Description**  $x = B/A$  solves the system of linear equations  $x*A = B$  for  $x$ . The matrices **A** and **B** must contain the same number of columns. MATLAB displays a warning message if **A** is badly scaled or nearly singular, but performs the calculation regardless.

- If **A** is a scalar, then  $B/A$  is equivalent to  $B ./ A$ .
- If **A** is a square  $n$ -by- $n$  matrix and **B** is a matrix with  $n$  columns, then  $x = B/A$  is a solution to the equation  $x*A = B$ , if it exists.
- If **A** is a rectangular  $m$ -by- $n$  matrix with  $m \neq n$ , and **B** is a matrix with  $n$  columns, then  $x = B/A$  returns a least-squares solution of the system of equations  $x*A = B$ .

$x = \text{mrdivide}(B,A)$  is an alternative way to execute  $x = B/A$ , but is rarely used. It enables operator overloading for classes.

## Input Arguments

**A - Coefficient matrix**  
 vector | full matrix | sparse matrix

Coefficient matrix, specified as a vector, full matrix, or sparse matrix. If **A** has  $n$  columns, then **B** must have  $n$  columns.

**Data Types**  
 single | double

**Complex Number Support:** Yes

**B - Right-hand side**  
 vector | full matrix | sparse matrix

Right-hand side, specified as a vector, full matrix, or sparse matrix. If **B** has  $n$  columns, then **A** must have  $n$  columns.

## Data Types

single | double

**Complex Number Support:** Yes

## Output Arguments

### x - Solution

vector | full matrix | sparse matrix

Solution, returned as a vector, full matrix, or sparse matrix. If A is an m-by-n matrix and B is a p-by-n matrix, then x is a p-by-m matrix.

x is sparse only if both A and B are sparse matrices.

## Examples

### System of Equations

Solve a system of equations that has a unique solution,  $x*A = B$ .

```
A = [1 1 3; 2 0 4; -1 6 -1];
```

```
B = [2 19 8];
```

```
x = B/A
```

```
x =
```

```
 1.0000 2.0000 3.0000
```

### Least-Squares on an Underdetermined System

Solve an underdetermined system,  $x*C = D$ .

```
C = [1 0; 2 0; 1 0];
```

```
D = [1 2];
```

```
x = D/C
```

```
Warning: Rank deficient, rank = 1, tol = 6.280370e-16.
```

```
x =
```

```
 0 0.5000 0
```

MATLAB issues a warning but proceeds with calculation.



Verify that  $x$  is not an exact solution.

```
x*C-D
```

```
ans =
```

```
 0 -2
```

**Tips**

- The operators `/` and `\` are related to each other by the equation  $B/A = (A' \setminus B')'$ .
- If  $A$  is a square matrix,  $B/A$  is roughly equal to  $B \cdot \text{inv}(A)$ , but MATLAB processes  $B/A$  differently and more robustly.

**See Also**

`mldivide` | `ldivide` | `rdivide` | `inv` | `transpose`

**Concepts**

- “Systems of Linear Equations”

# mlint

---

**Purpose** Check MATLAB code files for possible problems

---

**Note** `mlint` is not recommended. Use `checkcode` instead.

---

**Alternatives** For information on using the graphical user interface to the Code Analyzer, see “Check Code for Errors and Warnings”.

**Syntax**

```
mlint('filename')
mlint('filename', '-config=settings.txt')
mlint('filename', '-config=factory')
inform=mlint('filename', '-struct')
msg=mlint('filename', '-string')
[inform, filepaths]=mlint('filename')
inform=mlint('filename', '-id')
inform=mlint('filename', '-fullpath')
inform=mlint('filename', '-notok')
mlint('filename', '-cyc')
mlint('filename', '-codegen')
mlint('filename', '-eml')
```

**Description** `mlint('filename')` displays Code Analyzer messages about `filename`, where the message reports potential problems and opportunities for code improvement. The line number in the message is a hyperlink that opens the file in the Editor, scrolled to that line. If `filename` is a cell array, information is displayed for each file. For `mlint(F1,F2,F3,...)`, where each input is a character array, MATLAB software displays information about each input file name. You cannot combine cell arrays and character arrays of file names. Note that the exact text of the `mlint` messages is subject to some change between versions.

`mlint('filename', '-config=settings.txt')` overrides the default active settings file with the settings that enable or suppress messages as indicated in the specified `settings.txt` file.

---

**Note** If used, you must specify the full path to the `settings.txt` file specified with the `-config` option.

---

For information about creating a `settings.txt` file, see “Save and Reuse Code Analyzer Message Settings”. If you specify an invalid file, `mlint` returns a message indicating that it cannot open or read the file you specified. In that case, `mlint` uses the factory default settings.

`mlint('filename', '-config=factory')` ignores all settings files and uses the factory default preference settings.

`inform=mlint('filename', '-struct')` returns the information in a structure array whose length is the number of messages found. The structure has the fields that follow.

Field	Description
<code>message</code>	Message describing the suspicious construct that code analysis caught.
<code>line</code>	Vector of file line numbers to which the message refers.
<code>column</code>	Two-column array of file columns (column extents) to which the message applies. The first column of the array specifies the column in the Editor where the message begins. The second column of the array specifies the column in the Editor where the message ends. There is one row in the two-column array for each occurrence of a message.

If you specify multiple file names as input, or if you specify a cell array as input, `inform` contains a cell array of structures.

`msg=mlint('filename', '-string')` returns the information as a string to the variable `msg`. If you specify multiple file names as input, or if you specify a cell array as input, `msg` contains a string where each

file's information is separated by 10 equal sign characters (=), a space, the file name, a space, and 10 equal sign characters.

If you omit the **-struct** or **-string** argument and you specify an output argument, the default behavior is **-struct**. If you omit the argument and there are no output arguments, the default behavior is to display the information to the command line.

`[inform,filepath]=mlint('filename')` additionally returns `filepath`, the absolute paths to the file names, in the same order as you specified them.

`inform=mlint('filename','-id')` requests the message ID, where ID is a string of the form ABC... When returned to a structure, the output also has the `id` field, which is the ID associated with the message.

`inform=mlint('filename','-fullpath')` assumes that the input file names are absolute paths, so that `mlint` does not try to locate them.

`inform=mlint('filename','-notok')` runs `mlint` for all lines in `filename`, even those lines that end with the `mlint` suppression directive, `##ok`.

`mlint('filename','-cyc')` displays the McCabe complexity (also referred to as cyclomatic complexity) of each function in the file. Higher McCabe complexity values indicate higher complexity, and there is some evidence to suggest that programs with higher complexity values are more likely to contain errors. Frequently, you can lower the complexity of a function by dividing it into smaller, simpler functions. In general, smaller complexity values indicate programs that are easier to understand and modify. Some people advocate splitting up programs that have a complexity rating over 10.

`mlint('filename','-codegen')` enables code generation messages for display in the Command Window.

`mlint('filename','-eml')` `-eml` is not recommended. Use `-codegen` instead.

## Examples

The following examples use `lengthofline.m`, which is a sample file with MATLAB code that can be improved. You can find it in

*matlabroot/help/techdoc/matlab\_env/examples*. If you want to run the examples, save a copy of *lengthofline.m* to a location on your MATLAB path.

## Running mlint on a File with No Options

To run `mlint` on the example file, *lengthofline.m*, run

```
mlint('lengthofline')
```

MATLAB displays the M-Lint messages for *lengthofline.m* in the Command Window:

```
L 22 (C 1-9): The value assigned here to variable 'nothandle' might never be used.
L 23 (C 12-15): NUMEL(x) is usually faster than PROD(SIZE(x)).
L 24 (C 5-11): 'notline' might be growing inside a loop. Consider preallocating for speed.
L 24 (C 44-49): Use STRCMPI(str1,str2) instead of using LOWER in a call to STRCMP.
L 28 (C 12-15): NUMEL(x) is usually faster than PROD(SIZE(x)).
L 34 (C 13-16): 'data' might be growing inside a loop. Consider preallocating for speed.
L 34 (C 24-31): Use dynamic fieldnames with structures instead of GETFIELD.
 Type 'doc struct' for more information.
L 38 (C 29): Use || instead of | as the OR operator in (scalar) conditional statements.
L 39 (C 47): Use || instead of | as the OR operator in (scalar) conditional statements.
L 40 (C 47): Use || instead of | as the OR operator in (scalar) conditional statements.
L 42 (C 13-16): 'data' might be growing inside a loop. Consider preallocating for speed.
L 43 (C 13-15): 'dim' might be growing inside a loop. Consider preallocating for speed.
L 45 (C 13-15): 'dim' might be growing inside a loop.Consider preallocating for speed.
L 48 (C 52): There may be a parenthesis imbalance around here.
L 48 (C 53): There may be a parenthesis imbalance around here.
L 48 (C 54): There may be a parenthesis imbalance around here.
L 48 (C 55): There may be a parenthesis imbalance around here.
L 49 (C 17): Terminate statement with semicolon to suppress output (in functions).
L 49 (C 23): Use of brackets [] is unnecessary. Use parentheses to group, if needed.
```

For details about these messages and how to improve the code, see “Changing Code Based on Code Analyzer Messages” in the MATLAB Desktop Tools and Development Environment documentation.

## Running mlint with Options to Show IDs and Return Results to a Structure

To store the results to a structure and include message IDs, run

```
inform=mlint('lengthofline', '-id')
```

MATLAB returns

```
inform =

19x1 struct array with fields:
 message
 line
 column
 id
```

To see values for the first message, run

```
inform(1)
```

MATLAB displays

```
ans =

 message: 'The value assigned here to variable 'nohandle' might never be used.'
 line: 22
 column: [1 9]
 id: 'NASGU'
```

Here, the message is for the value that appears on line 22 that extends from column 1–9 in the file.NASGU is the ID for the message 'The value assigned here to variable 'nohandle' might never be used.'.

## Displaying McCabe Complexity with mlint

To display the McCabe complexity of a MATLAB code file, run `mlint` with the `-cyc` option, as shown in the following example (assuming you have saved `lengthofline.m` to a local folder).

```
mlint lengthofline.m -cyc
```

Results displayed in the Command Window show the McCabe complexity of the file, followed by the M-Lint messages, as shown here:

```
L 1 (C 23-34): The McCabe complexity of 'lengthofline' is 12.
L 22 (C 1-9): The value assigned here to variable 'nohandle' might never be used.
L 23 (C 12-15): NUMEL(x) is usually faster than PROD(SIZE(x)).
L 24 (C 5-11): 'notline' might be growing inside a loop. Consider preallocating for speed.
L 24 (C 44-49): Use STRCMP(str1,str2) instead of using UPPER/LOWER in a call to STRCMP.
L 28 (C 12-15): NUMEL(x) is usually faster than PROD(SIZE(x)).
L 34 (C 13-16): 'data' might be growing inside a loop. Consider preallocating for speed.
L 34 (C 24-31): Use dynamic fieldnames with structures instead of GETFIELD. Type 'doc struct' for mo
L 38 (C 29): Use || instead of | as the OR operator in (scalar) conditional statements.
L 39 (C 47): Use || instead of | as the OR operator in (scalar) conditional statements.
L 40 (C 47): Use || instead of | as the OR operator in (scalar) conditional statements.
L 42 (C 13-16): 'data' might be growing inside a loop. Consider preallocating for speed.
L 43 (C 13-15): 'dim' might be growing inside a loop. Consider preallocating for speed.
L 45 (C 13-15): 'dim' might be growing inside a loop. Consider preallocating for speed.
L 48 (C 52): There may be a parenthesis imbalance around here.
L 48 (C 53): There may be a parenthesis imbalance around here.
L 48 (C 54): There may be a parenthesis imbalance around here.
L 48 (C 55): There may be a parenthesis imbalance around here.
L 49 (C 17): Terminate statement with semicolon to suppress output (in functions).
L 49 (C 23): Use of brackets [] is unnecessary. Use parentheses to group, if needed.
```

## See Also

mlintrpt, profile

## How To

- For information on the suppression directive, `%#ok`, and suppressing messages from within your program, see “Adjust Code Analyzer Message Indicators and Messages”.

# mlintrpt

---

**Purpose** Run checkcode for file or folder, reporting results in browser

**Syntax**

```
mlintrpt
mlintrpt('filename','file')
mlintrpt('dirname','dir')
mlintrpt('filename','file','settings.txt')
mlintrpt('dirname','dir','settings.txt')
```

**Description** `mlintrpt` scans all files with an `.m` file extension in the current folder for Code Analyzer messages and reports the results in a MATLAB Web browser.

`mlintrpt('filename','file')` scans `filename` for Code Analyzer messages and reports results. You can omit `'file'` in this form of the syntax because it is the default.

`mlintrpt('dirname','dir')` scans the specified folder. Here, `dirname` can be in the current folder or can be a full path.

`mlintrpt('filename','file','settings.txt')` applies the Code Analyzer preference settings to enable or suppress messages as indicated in the specified `settings.txt` file.

`mlintrpt('dirname','dir','settings.txt')` applies the settings indicated in the specified `settings.txt` file.

---

**Note** If you specify a `settings.txt` file, you must specify the full path to the file.

---

**Examples** `lengthofline.m` is an example file with code that can be improved. It is found in `matlabroot/matlab/help/techdoc/matlab_env/examples`.

## Run Report for All Files in a Folder

Run

```
mlintrpt(fullfile(matlabroot,'help','techdoc','matlab_env','examples'),'dir')
```



and MATLAB displays a report of potential problems and improvements for all files with an `.m` file extension in the `examples` folder.

For details about these messages and how to improve the code, see “Changing Code Based on Code Analyzer Messages”.

### Run Report Using Code Analyzer Preference Settings

You can save preference settings to a text file by clicking the **Preferences** button in the **Environment** section on the **Home** tab and selecting **Code Analyzer** in the left pane. To save a preferences file, select **Save as** under the  drop-down list. To apply those settings when you run `mlintrpt`, use the `file` option and supply the full path to the settings file name as shown in this example:

```
mlintrpt('lengthofline.m', 'file', ...
'C:\WINNT\Profiles\me\Application Data\MathWorks\MATLAB\R2012b\mymlint.txt')
```

Alternatively, use `fullfile` if the settings file is stored in the preferences folder:

```
mlintrpt('lengthofline.m', 'file', fullfile(prefdir, 'mymlint.txt'))
```

Assuming that in that example `mymlint.txt` file, the setting for **Terminate statement with semicolon to suppress output** has been disabled, the results of `mlintrpt` for `lengthofline` do not show that message for line 49.

When `mlintrpt` cannot locate the settings file, the first message in the report is

```
0: Unable to open or read the configuration file 'mymlint.txt'--using default settings.
```

## See Also

`checkcode`

## Concepts

- “Check Code for Errors and Warnings”

# mlock

---

**Purpose** Prevent clearing function from memory

**Syntax** `mlock`

**Description** `mlock` locks the currently running function in memory so that subsequent `clear` functions do not remove it. Locking a function in memory also prevents any persistent variables defined in the file from getting reinitialized.

Use the `munlock` function to return the file to its normal, clearable state.

**Examples** The function `testfun` begins with an `mlock` statement.

```
function testfun
mlock
.
.
```

When you execute this function, it becomes locked in memory. You can check this using the `mislocked` function.

```
testfun

mislocked('testfun')
ans =
 1
```

Using `munlock`, you unlock the `testfun` function in memory. Checking its status with `mislocked` shows that it is indeed unlocked at this point.

```
munlock('testfun')

mislocked('testfun')
ans =
 0
```

**See Also** `mislocked` | `munlock` | `inmem` | `persistent`

**Purpose** Information about multimedia file

**Syntax** `info = mmfileinfo(filename)`

**Description** `info = mmfileinfo(filename)` returns a structure, *info*, with fields containing information about the contents of the multimedia file identified by *filename*. The *filename* input is a string enclosed in single quotation marks.

If *filename* is a URL, `mmfileinfo` might take a long time to return because it must first download the file. For large files, downloading can take several minutes. To avoid blocking the MATLAB command line while this processing takes place, download the file before calling `mmfileinfo`.

The *info* structure contains the following fields, listed in the order they appear in the structure.

Field	Description
Filename	String indicating the name of the file.
Path	String indicating the absolute path to the file.
Duration	Length of the file in seconds.
Audio	Structure containing information about the audio data in the file. See “Audio Data” on page 1-4394 for more information about this data structure.
Video	Structure containing information about the video data in the file. See “Video Data” on page 1-4394 for more information about this data structure.

## Audio Data

The Audio structure contains the following fields, listed in the order they appear in the structure. If the file does not contain audio data, the fields in the structure are empty.

Field	Description
Format	Text string, indicating the audio format.
NumberOfChannels	Number of audio channels.

## Video Data

The Video structure contains the following fields, listed in the order they appear in the structure. If the file does not contain video data, the fields in the structure are empty.

Field	Description
Format	Text string, indicating the video format.
Height	Height of the video frame.
Width	Width of the video frame.

## Examples

Display information about the example file `xylophone.mpg`:

```
info = mmfileinfo('xylophone.mpg')
audio = info.Audio
video = info.Video
```

MATLAB returns:

```
info =
 Filename: 'xylophone.mpg'
 Path: 'matlabroot\toolbox\matlab\audiovideo'
 Duration: 4.7020
 Audio: [1x1 struct]
 Video: [1x1 struct]
```

```
audio =
 Format: 'MPEG'
 NumberOfChannels: 2
```

```
video =
 Format: 'MPEG1'
 Height: 240
 Width: 320
```

where Path is system-dependent.

## See Also

[get | VideoReader](#)

# mmreader

---

**Purpose** Create object for reading video files

---

**Note** mmreader has been removed. Use VideoReader instead.

---

**Description** Use mmreader with the read method to read video data from a multimedia file into the MATLAB workspace.

The file formats that mmreader supports vary by platform, as follows (with no restrictions on file extensions):

All Platforms	Motion JPEG 2000 (.mj2)
Windows	AVI (.avi), MPEG-1 (.mpg), Windows Media Video (.wmv, .asf, .asx), and any format supported by Microsoft DirectShow.
Macintosh	AVI (.avi), MPEG-1 (.mpg), MPEG-4 (.mp4, .m4v), Apple QuickTime Movie (.mov), and any format supported by QuickTime as listed on <a href="http://support.apple.com/kb/HT3775">http://support.apple.com/kb/HT3775</a> .
Linux	Any format supported by your installed plug-ins for GStreamer 0.10 or above, as listed on <a href="http://gstreamer.freedesktop.org/documentation/plugins.html">http://gstreamer.freedesktop.org/documentation/plugins.html</a> , including AVI (.avi) and Ogg Theora (.ogg).

For more information, see “Supported Video File Formats” in the MATLAB Data Import and Export documentation.

**Construction** `obj = mmreader(filename)` constructs `obj` to read video data from the file named `filename`. The mmreader constructor searches for the file on the MATLAB path. If it cannot construct the object for any reason, mmreader generates an error.

```
obj = mmreader(filename, 'PropertyName', PropertyValue)
```

constructs the object using options, specified as property name/value pairs. Property name/value pairs can be in any format that the set method supports: name/value string pairs, structures, or name/value cell array pairs.

## Properties

### **BitsPerPixel**

Bits per pixel of the video data. (Read-only)

### **Duration**

Total length of the file in seconds. (Read-only)

### **FrameRate**

Frame rate of the video in frames per second. (Read-only)

### **Height**

Height of the video frame in pixels. (Read-only)

### **Name**

Name of the file associated with the object. (Read-only)

### **NumberOfFrames**

Total number of frames in the video stream. (Read-only)

Some files store video at a variable frame rate, including many Windows Media Video files. For these files, mmreader cannot determine the number of frames until you read the last frame. When you construct the object, mmreader returns a warning and does not set the NumberOfFrames property.

To count the number of frames in a variable frame rate file, use the read method to read the last frame of the file. For example:

```
vidObj = mmreader('varFrameRateFile.wmv');
lastFrame = read(vidObj, inf);
numFrames = vidObj.NumberOfFrames;
```

# mmreader

---

For more information, see “Read Variable Frame Rate Video” in the MATLAB Data Import and Export documentation.

## **Path**

String containing the full path to the file associated with the reader. (Read-only)

## **Tag**

User-defined string to identify the object.

**Default:** ''

## **Type**

Class name of the object: 'mmreader'. (Read-only)

## **UserData**

Generic field for user-defined data.

**Default:** []

## **VideoFormat**

String indicating the MATLAB representation of the video format, such as 'RGB24'. (Read-only)

## **Width**

Width of the video frame in pixels. (Read-only)

## **Methods**

For backward compatibility, mmreader supports the following VideoReader methods:

get	Query property values for video reader object
getFileFormats	File formats that VideoReader supports



read	Read video frame data from file
set	Set property values for video reader object

## Copy Semantics

Handle. To learn how handle classes affect copy operations, see Copying Objects in the MATLAB Programming Fundamentals documentation.

## Examples

Construct an mmreader object for the example movie file xylophone.mpg and view its properties:

```
xyloObj = mmreader('xylophone.mpg', 'Tag', 'My reader object');
get(xyloObj)
```

---

Read and play back the movie file xylophone.mpg:

```
xyloObj = mmreader('xylophone.mpg');

nFrames = xyloObj.NumberOfFrames;
vidHeight = xyloObj.Height;
vidWidth = xyloObj.Width;

% Preallocate movie structure.
mov(1:nFrames) = ...
 struct('cdata', zeros(vidHeight, vidWidth, 3, 'uint8'),...
 'colormap', []);

% Read one frame at a time.
for k = 1 : nFrames
 mov(k).cdata = read(xyloObj, k);
end

% Size a figure based on the video's width and height.
hf = figure;
set(hf, 'position', [150 150 vidWidth vidHeight])
```

# mmreader

---

```
% Play back the movie once at the video's frame rate.
movie(hf, mov, 1, xyloObj.FrameRate);
```

## See Also

mmfileinfo | VideoReader

## How To

- “Read Video Files”

<b>Purpose</b>	Modulus after division
<b>Syntax</b>	$M = \text{mod}(X, Y)$
<b>Description</b>	<p><math>M = \text{mod}(X, Y)</math> returns the modulus after division of <math>X</math> by <math>Y</math>. In general, if <math>Y</math> does not equal 0, <math>M = \text{mod}(X, Y)</math> returns <math>X - n.*Y</math>, where <math>n = \text{floor}(X./Y)</math>. If <math>Y</math> is not an integer and the quotient <math>X./Y</math> is within roundoff error of an integer, then <math>n</math> is that integer. Inputs <math>X</math> and <math>Y</math> must have the same dimensions unless one is a scalar double. If one input has an integer data type, then the other input must be of the same integer data type or be a scalar double.</p> <p>The following are true by convention:</p> <ul style="list-style-type: none"><li>• <math>\text{mod}(X, 0)</math> is <math>X</math>.</li><li>• <math>\text{mod}(X, X)</math> is 0.</li><li>• <math>\text{mod}(X, Y)</math> for <math>X \sim Y</math> and <math>Y \sim 0</math> has the same sign as <math>Y</math>.</li></ul>
<b>Input Arguments</b>	<p><b>X - Dividend</b> scalar   vector   matrix   multidimensional array</p> <p>Dividend, specified as a scalar, vector, matrix, or multidimensional array. Must be a real-valued number of any numerical type.</p> <p><b>Data Types</b> single   double   int8   int16   int32   int64   uint8   uint16   uint32   uint64   char</p> <p><b>Y - Divisor</b> scalar   vector   matrix   multidimensional array</p> <p>Divisor, specified as a scalar, vector, matrix, or multidimensional array. Must be a real-valued number of any numerical type.</p> <p><b>Data Types</b> single   double   int8   int16   int32   int64   uint8   uint16   uint32   uint64   char</p>

## Examples

### Modulus of Two Scalars

Compute 23 modulo 5.

```
X = 23;
Y = 5;
M = mod(X,Y)
```

M =

3

### Modulus of a Vector

Create a vector, then use `mod` to find the modulus after dividing a scalar into each element of the vector.

```
X = 1:5;
Y = 3;
M = mod(X,Y)
```

M =

1 2 0 1 2

When you specify one or more of the inputs as an array, the `mod` function acts on each array element independently.

### Modulus of Two Arrays

Create two 3-by-3 matrices, then use `mod` to find the modulus after dividing `Y` into `X`.

```
X = [1 2 3;4 5 6;7 8 9];
Y = [9 8 7;6 5 4;3 2 1];
M = mod(X,Y)
```

M =

1 2 3

```

4 0 2
1 0 0

```

Inputs  $X$  and  $Y$  must have the same dimensions unless one is a scalar double.

### Forced Rounding in mod

If  $Y$  is not an integer and  $X./Y$  is within roundoff error of an integer, then `mod` rounds to that integer for its calculation. The size of the roundoff error is very small.

```

X = 2;
Y = 2 - eps(2)

```

```

Y =
 2.0000

```

It looks like  $Y$  is trivially equal to 2, but in fact there is an infinitesimal difference.

```

2 - Y
ans =
 4.4409e-16

```

This difference is forced to zero by `mod` if it is small enough.

```

M = mod(X,Y)
M =
 0

```

Make the difference a little larger and the forced rounding disappears.

```

Y = 2 - eps(4);

```

# mod

---

```
M = mod(X,Y)
```

```
M =
```

```
8.8818e-16
```

## Difference Between mod and rem

Define X and Y with different signs.

```
X = 5;
```

```
Y = -2;
```

Compute the modulus after division with `mod`, then compute the remainder after division with `rem`.

```
M = mod(X,Y)
```

```
M =
```

```
-1
```

```
R = rem(X,Y)
```

```
R =
```

```
1
```

`mod(X,Y)` and `rem(X,Y)` are equal if X and Y have the same sign, but differ by Y if X and Y have different signs. Notice that `mod` retains the sign of Y, while `rem` retains the sign of X.

## Tips

- The `mod` function is useful for congruence relationships: *x* and *y* are congruent (mod *m*) if and only if `mod(x,m) == mod(y,m)`. For example, 23 and 13 are congruent (mod 5).

## See Also

`rem`

**Purpose** Most frequent values in array

**Syntax**  
`M = mode(X)`  
`M = mode(X, dim)`

`[M, F] = mode( ___ )`  
`[M, F, C] = mode( ___ )`

**Description** `M = mode(X)` returns the sample mode of `X`, which is the most frequently occurring value in `X`. When there are multiple values occurring equally frequently, `mode` returns the smallest of those values. For complex inputs, the smallest value is the first value in a sorted list.

- If `X` is a vector, then `mode(X)` returns the most frequent value of `X`.
- If `X` is a nonempty matrix, then `mode(X)` returns a row vector containing the mode of each column of `X`.
- If `X` is an empty 0-by-0 matrix, `mode(X)` returns NaN.
- If `X` is a multidimensional array, then `mode(X)` acts along the first nonsingleton dimension and returns an array of most frequent values. The size of this dimension reduces to 1 while the sizes of all other dimensions remain the same.

`M = mode(X, dim)` returns the mode of elements along dimension `dim`. For example, if `X` is a matrix, then `mode(X, 2)` is a column vector containing the most frequent value of each row

`[M, F] = mode( ___ )` also returns a frequency array `F`, using any of the input arguments in the previous syntaxes. `F` is the same size as `M`, and each element of `F` represents the number of occurrences of the corresponding element of `M`.

`[M, F, C] = mode( ___ )` also returns a cell array `C` of the same size as `M` and `F`. Each element of `C` is a sorted vector of all values that have the same frequency as the corresponding element of `M`.

# mode

## Input Arguments

### X - Input array

vector | matrix | multidimensional array

Input array, specified as a vector, matrix, or multidimensional array.

NaN values in the input array, X, are ignored.

### Data Types

double | single | int8 | int16 | int32 | int64 | uint8 | uint16 | uint32 | uint64

### dim - Dimension to operate along

positive integer scalar

Dimension to operate along, specified as a positive integer scalar. If no value is specified, the default is the first array dimension whose size does not equal 1.

Dimension `dim` indicates the dimension whose length reduces to 1. The `size(M,dim)` is 1, while the sizes of all other dimensions remain the same.

Consider a two-dimensional input array, X.

- If `dim = 1`, then `mode(X,1)` returns a row vector containing the most frequent value in each column.
- If `dim = 2`, then `mode(X,2)` returns a column vector containing the most frequent value in each row.

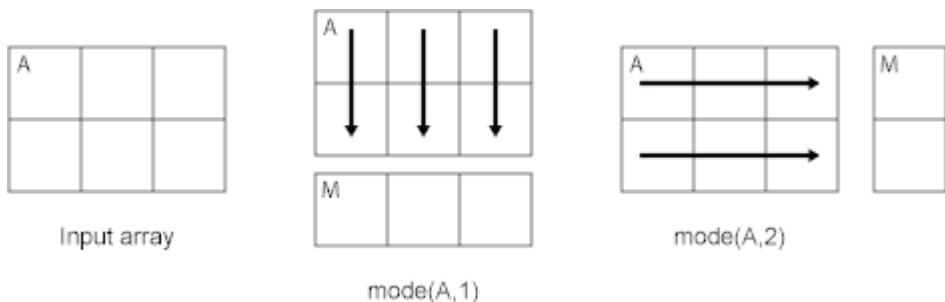

`mode` returns X if `dim` is greater than `ndims(X)`.



**Data Types**

double | single | int8 | int16 | int32 | int64 | uint8 |  
uint16 | uint32 | uint64

**Output  
Arguments****M - Most frequent values**

scalar | vector | matrix | multidimensional array

Most frequent values returned as a scalar, vector, matrix, or multidimensional array. When there are multiple values occurring equally frequently, `mode` returns the smallest of those values. For complex inputs, this is taken to be the first value in a sorted list of values.

The class of `M` is the same as the class of the input array, `X`.

**F - Frequency array**

scalar | vector | matrix | multidimensional array

Frequency array returned as a scalar, vector, matrix, or multidimensional array. The size of `F` is the same as the size of `M`, and each element of `F` represents the number of occurrences of the corresponding element of `M`.

The class of `F` is always `double`.

**C - Most frequent values with multiplicity**

cell array

Most frequent values with multiplicity returned as a cell array. The size of `C` is the same as the size of `M` and `F`, and each element of `C` is a sorted column vector of all values that have the same frequency as the corresponding element of `M`.

**Definitions****First Nonsingleton Dimension**

The first nonsingleton dimension is the first dimension of an array whose size is not equal to 1.

For example:

# mode

---

- If  $X$  is a 1-by- $n$  row vector, then the second dimension is the first nonsingleton dimension of  $X$ .
- If  $X$  is a 1-by-0-by- $n$  empty array, then the second dimension is the first nonsingleton dimension of  $X$ .
- If  $X$  is a 1-by-1-by-3 array, then the third dimension is the first nonsingleton dimension of  $X$ .

## Tips

- The mode function is most useful with discrete or coarsely rounded data. The mode for a continuous probability distribution is defined as the peak of its density function. Applying the mode function to a sample from that distribution is unlikely to provide a good estimate of the peak; it would be better to compute a histogram or density estimate and calculate the peak of that estimate. Also, the mode function is not suitable for finding peaks in distributions having multiple modes.

## Examples

### Mode of Matrix Columns

Define a 3-by-4 matrix.

```
X = [3 3 1 4; 0 0 1 1; 0 1 2 4]
```

```
X =
```

```
 3 3 1 4
 0 0 1 1
 0 1 2 4
```

Find the most frequent value of each column.

```
M = mode(X)
```

```
M =
```

```
 0 0 1 4
```

### Mode of Matrix Rows

Define a 3-by-4 matrix.

```
X = [3 3 1 4; 0 0 1 1; 0 1 2 4]
```

```
X =
```

```
 3 3 1 4
 0 0 1 1
 0 1 2 4
```

Find the most frequent value of each row.

```
M = mode(X,2)
```

```
M =
```

```
 3
 0
 0
```

### Mode of 3-D Array

Create a 1-by-3-by-4 array of integers between 1 and 10.

```
X = gallery('integerdata',10,[1,3,4],1)
```

```
X(:,:,1) =
```

```
 10 8 10
```

```
X(:,:,2) =
```

```
 6 9 5
```

```
X(:,:,3) =
```

# mode

---

```
9 6 1
```

```
X(:,:,4) =
```

```
4 9 5
```

Find the most frequent values of this 3-D array along the second dimension.

```
M = mode(X)
```

```
M(:,:,1) =
```

```
10
```

```
M(:,:,2) =
```

```
5
```

```
M(:,:,3) =
```

```
1
```

```
M(:,:,4) =
```

```
4
```

This operation produces a 1-by-1-by-4 array by finding the most frequent value along the second dimension. The size of the second dimension reduces to 1.

Compute the mode along the first dimension of X.

```
M = mode(X,1);
isequal(X,M)
```

```
ans =
```

```
1
```

This returns the same array as  $X$  because the size of the first dimension is 1.

### Mode of Matrix Columns with Frequency Information

Define a 3-by-4 matrix.

```
X = [3 3 1 4; 0 0 1 1; 0 1 2 4]
```

```
X =
```

```
3 3 1 4
0 0 1 1
0 1 2 4
```

Find the most frequent value of each column, as well as how often it occurs.

```
[M,F] = mode(X)
```

```
M =
```

```
0 0 1 4
```

```
F =
```

```
2 1 2 2
```

$F(1)$  is 2 since  $M(1)$  occurs twice in the first column.

## Mode of Matrix Rows with Frequency and Multiplicity Information

Define a 3-by-4 matrix.

```
X = [3 3 1 4; 0 0 1 1; 0 1 2 4]
```

```
X =
```

```
 3 3 1 4
 0 0 1 1
 0 1 2 4
```

Find the most frequent value of each row, how often it occurs, and which values in that row occur with the same frequency.

```
[M,F,C] = mode(X,2)
```

```
M =
```

```
 3
 0
 0
```

```
F =
```

```
 2
 2
 1
```

```
C =
```

```
 [3]
 [2x1 double]
 [4x1 double]
```

$C\{2\}$  is the 2-by-1 vector  $[0;1]$  since values 0 and 1 in the second row occur with frequency  $F(2)$ .

$C\{3\}$  is the 4-by-1 vector  $[0;1;2;4]$  since all values in the third row occur with frequency  $F(3)$ .

### Mode of 16-bit Unsigned Integer Array

Define a 1-by-4 vector of 16-bit unsigned integers.

```
X = gallery('integerdata',10,[1,4],3,'uint16')
```

```
X =
```

```
 6 3 2 3
```

Find the most frequent value, as well as the number of times it occurs.

```
[M,F] = mode(X),
class(M)
```

```
M =
```

```
 3
```

```
F =
```

```
 2
```

```
ans =
```

```
uint16
```

$M$  is the same class as the input,  $X$ .

### See Also

[mean](#) | [median](#) | [hist](#) | [histc](#) | [sort](#)

# more

---

**Purpose** Control paged output for Command Window

**Syntax**

```
more on
more off
more(n)
A = more(state)
```

**Description** `more on` enables paging of the output in the MATLAB Command Window. MATLAB displays output one page at a time. Use the keys defined in the table below to control paging.

`more off` disables paging of the output in the MATLAB Command Window.

`more(n)` defines the length of a page to be `n` lines.

`A = more(state)` returns in `A` the number of lines that are currently defined to be a page. The `state` input can be one of the quoted strings `'on'` or `'off'`, or the number of lines to set as the new page length.

By default, the length of a page is equal to the number of lines available for display in the MATLAB Command Window. Manually changing the size of the command window adjusts the page length accordingly.

If you set the page length to a specific value, MATLAB uses that value for the page size, regardless of the size of the command window. To have MATLAB return to matching page size to window size, type `more off` followed by `more on`.

To see the status of `more`, type `get(0, 'More')`. MATLAB returns either `on` or `off`, indicating the `more` status.

When you have enabled `more` and are examining output, you can do the following.



<b>Press the...</b>	<b>To...</b>
Return key	Advance to the next line of output.
Space bar	Advance to the next page of output.
Q (for quit) key	Terminate display of the text. Do not use <b>Ctrl+C</b> to terminate <b>more</b> or you might generate error messages in the Command Window.

**more** is in the **off** state, by default.

**See Also**

diary

# move

---

**Purpose** Move or resize control in parent window

**Syntax** `V = h.move(position)`  
`V = move(h, position)`

**Description** `V = h.move(position)` moves the control to the position specified by the `position` argument. When you use `move` with only the handle argument, `h`, it returns a four-element vector indicating the current position of the control.

`V = move(h, position)` is an alternate syntax.

The `position` argument is a four-element vector specifying the position and size of the control in the parent figure window. The elements of the vector are:

`[x, y, width, height]`

where `x` and `y` are offsets, in pixels, from the bottom left corner of the figure window to the same corner of the control, and `width` and `height` are the size of the control itself.

**Examples** This example moves the control:

```
f = figure('Position', [100 100 200 200]);
h = actxcontrol('mwsamp.mwsampctrl.1', [0 0 200 200], f);
pos = h.move([50 50 200 200])
```

```
pos =
 50 50 200 200
```

The next example resizes the control to always be centered in the figure as you resize the figure window. Start by creating the script `resizectl.m` that contains

```
% Get the new position and size of the figure window
fpos = get(gcbo, 'position');
```

---

```
% Resize the control accordingly
h.move([0 0 fpos(3) fpos(4)]);
```

Now execute the following:

```
f = figure('Position', [100 100 200 200]);
h = actxcontrol('mwsamp.mwsampctrl.1', [0 0 200 200]);
set(f, 'ResizeFcn', 'resizectrl');
```

As you resize the figure window, notice that the circle moves so that it is always positioned in the center of the window.

## See Also

set (COM) | get (COM)

# movefile

---

## Purpose

Move file or folder

## Syntax

```
movefile('source')
movefile('source','destination')
movefile('source','destination','f')
[status,message,messageid] = movefile(___)
```

## Description

`movefile('source')` moves the file or folder named `source` to the current folder, where `source` is the absolute or relative path name for the folder or file. To move multiple files or folders, use one or more wildcard characters (\*) after the last file separator in `source`. The `source` argument permits a wildcard character in a path string. `movefile` does not preserve the archive attribute of `source`.

`movefile('source','destination')` moves the file or folder named `source` to the location `destination`, where `source` and `destination` are the absolute or relative paths for the folder or file. To move multiple files or folders, you can use one or more wildcard characters (\*) after the last file separator in `source`. You cannot use a wildcard character in `destination`. To rename a file or folder when moving it, make `destination` a different name than `source`, and specify only one file for `source`. When `source` and `destination` have the same location, `movefile` renames `source` to `destination`.

`movefile('source','destination','f')` moves the file or folder named `source` to the location `destination`, regardless of the read-only attribute of `destination`.

`[status,message,messageid] = movefile( ___ )` moves the file or folder named `source` to the location `destination`, returning the `status`, a message, and the MATLAB message ID. Here, `status` is logical 1 for success or logical 0 for error. `movefile` requires only one output argument.

## Examples

### Moving a File to the Current Folder

Assuming `myfiles` is a subfolder within the current folder, move the file `myfunction.m` to the current folder:

```
movefile('myfiles/myfunction.m')
```

Assuming `projects/testcases` is the current folder, move `projects/myfiles` and its contents to the current folder:

```
movefile('../myfiles')
```

## Renaming a File in the Current Folder

In the current folder, rename `myfunction.m` to `oldfunction.m`:

```
movefile('myfunction.m','oldfunction.m')
```

## Using a Wildcard to Move All Matching Files

Assuming `myfiles` is a subfolder of the current folder, move all files whose names that begin with `my` from the `myfiles` folder, to the current folder:

```
movefile('myfiles/my*')
```

## Moving a File to a Different Folder

Assuming `projects` and the current folder are at the same level, move the file `myfunction.m` from the current folder to the folder `projects`:

```
movefile('myfunction.m','../projects')
```

## Moving a Folder Down One Level

Assuming `projects` is a subfolder of the current folder, move the folder `projects/testcases` and all its contents down a level in `projects` into `projects/myfiles`:

```
movefile('projects/testcases','projects/myfiles/')
```

## Moving a File to a Read-Only Folder and Renaming the File

Move the file `myfile.m` from the current folder to `d:/work/restricted`, assigning it the name `test1.m`, where `restricted` is a read-only folder:

```
movefile('myfile.m','d:/work/restricted/test1.m','f')
```

# movefile

---

The read-only file `myfile.m` is no longer in the current folder. The file `test1.m` is in `d:/work/restricted` and is read only.

## Returning Status When Moving Files

Move all files in the folder `myfiles` whose names start with `new` to the current folder, when there is an error. You mistype `new*` as `nex*` and no items in the current folder start with `nex*`:

```
[s,mess,messid] = movefile('myfiles/nex*')
```

```
s =
 0
```

```
mess =
```

```
No matching files were found.
```

```
messid =
```

```
MATLAB:MOVEFILE:FileDoesNotExist
```

## See Also

```
cd | copyfile | delete | dir | fileattrib | ls | mkdir | rmdir
```

## How To

- “Manage Files and Folders”

**Purpose** Move GUI figure to specified location on screen

**Syntax**

```
movegui(h, 'position')
movegui(position)
movegui(h)
movegui
```

**Description** `movegui(h, 'position')` moves the figure identified by handle `h` to the specified screen location, preserving the figure's size. The `position` argument is either a string or a two-element vector, as defined in the tables that follow.

`movegui(position)` moves the callback figure (`gcbf`) or the current figure (`gcf`) to the specified position.

`movegui(h)` moves the figure identified by the handle `h` to the onscreen position.

`movegui` moves the callback figure (`gcbf`) or the current figure (`gcf`) to the onscreen position. You can specify 'movegui' as a `CreateFcn` callback for a figure. Doing so ensures after you save a figure, that figure appears on screen when you reload it, regardless of its saved position. See the following example.

When it is a string, `position` is one of the following descriptors.

Position String	Description
north	Top center edge of screen
south	Bottom center edge of screen
east	Right center edge of screen
west	Left center edge of screen
northeast	Top right corner of screen
northwest	Top left corner of screen
southeast	Bottom right corner of screen

# movegui

---

Position String	Description
southwest	Bottom left corner
center	Centered on screen
onscreen	Nearest location to current location that is entirely on screen

You can also specify the *position* argument as a two-element vector,  $[h, v]$ . Depending on sign,  $h$  specifies the figure's offset from the left or right edge of the screen, and  $v$  specifies the figure's offset from the top or bottom of the screen, in pixels. The following table summarizes the possible values.

$h$ (for $h \geq 0$ )	Offset of left side from left edge of screen
$h$ (for $h < 0$ )	Offset of right side from right edge of screen
$v$ (for $v \geq 0$ )	Offset of bottom edge from bottom of screen
$v$ (for $v < 0$ )	Offset of top edge from top of screen

Applying `movegui` to a maximized figure window moves the window towards the task bar and creates a gap on the opposite side of the screen about as wide as the task bar. The window might shrink in size by a few pixels. If you use the `onscreen` option with a maximized figure window, then `movegui` creates a gap on both the left and upper sides of the screen so that the top-left corner of the figure is visible.

`GUIDE` and `openfig` call `movegui` when loading figures to ensure they are visible.

## Examples

Ensure that a saved GUI appears on screen when you reload it, regardless of the target computer screen size and resolution. Create a



---

figure that is off the screen, assign `movegui` as its `CreateFcn` callback, save the figure, and then reload it.

```
f = figure('Position',[10000,10000,400,300]);
% The figure does not display because
% it is created offscreen.
set(f,'CreateFcn','movegui')
hgsave(f,'onscreenfig')
close(f)
f2 = hgload('onscreenfig');
% The reloaded figure is now visible
```

---

Move a figure to the bottom left corner of the screen.

```
f = figure;
movegui(f,'southwest');
```

---

Move a figure so that it is offset 100 pixels from the bottom and left side of the screen.

```
f = figure;
movegui(f,[100,100]);
```

## See Also

[guide](#) | [openfig](#)

## How To

- “Positioning Figures”

# movie

---

**Purpose** Play recorded movie frames

**Syntax**

```
movie(M)
movie(M,n)
movie(M,n,fps)
movie(h,...)
movie(h,M,n,fps,loc)
```

**Description** The `movie` function plays the movie defined by a matrix whose columns are movie frames (usually produced by `getframe`).

`movie(M)` plays the movie in matrix `M` once, using the current axes as the default target. If you want to play the movie in the figure instead of the axes, specify the figure handle (or `gcf`) as the first argument: `movie(figure_handle,...)`. `M` must be an array of movie frames (usually from `getframe`).

`movie(M,n)` plays the movie `n` times. If `n` is negative, each cycle is shown forward then backward. If `n` is a vector, the first element is the number of times to play the movie, and the remaining elements make up a list of frames to play in the movie.

For example, if `M` has four frames then `n = [10 4 4 2 1]` plays the movie ten times, and the movie consists of frame 4 followed by frame 4 again, followed by frame 2 and finally frame 1.

`movie(M,n,fps)` plays the movie at `fps` frames per second. The default is 12 frames per second. Computers that cannot achieve the specified speed play as fast as possible.

`movie(h,...)` plays the movie centered in the figure or axes identified by the handle `h`. Specifying the figure or axes enables MATLAB to fit the movie to the available size.

`movie(h,M,n,fps,loc)` specifies `loc`, a four-element location vector, `[x y 0 0]`, where the lower left corner of the movie frame is anchored (only the first two elements in the vector are used). The location is relative to the lower left corner of the figure or axes specified by handle `h` and in units of pixels, regardless of the object's `Units` property.

**Tips**

The `movie` function uses a default figure size of 560-by-420 and does not resize figures to fit movies with larger or smaller frames. To accommodate other frame sizes, you can resize the figure to fit the movie, as shown in the second example below.

`movie` only accepts 8-bit image frames; it does not accept 16-bit grayscale or 24-bit truecolor image frames.

Buffering the movie places all frames in memory. As a result, on Microsoft Windows and perhaps other platforms, a long movie (on the order of several hundred frames) can exhaust memory, depending on system resources. In such cases an error message is issued that says

```
??? Error using ==> movie
Could not create movie frame
```

You can abort a movie by typing **Ctrl-C**.

`movie` is not a built-in function. Therefore, you cannot call `movie` using the `builtin` function.

**Limitations with Renderer on Windows Systems**

Setting the figure `Renderer` property to `zbuffer` or `painters` works around limitations of using `getframe` with the OpenGL renderer on some Windows systems.

**Examples**

Animate the `peaks` function as you scale the values of `Z`:

```
figure('Renderer','zbuffer')
Z = peaks;
surf(Z);
axis tight manual
set(gca,'NextPlot','replaceChildren');
% Preallocate the struct array for the struct returned by getframe
F(20) = struct('cdata',[],'colormap',[]);
% Record the movie
for j = 1:20
 surf(.01+sin(2*pi*j/20)*Z,Z)
 F(j) = getframe;
```

# movie

---

```
end
```

Now play the movie ten times. The twelfth frame looks like the following plot.

```
movie(F,10)
```

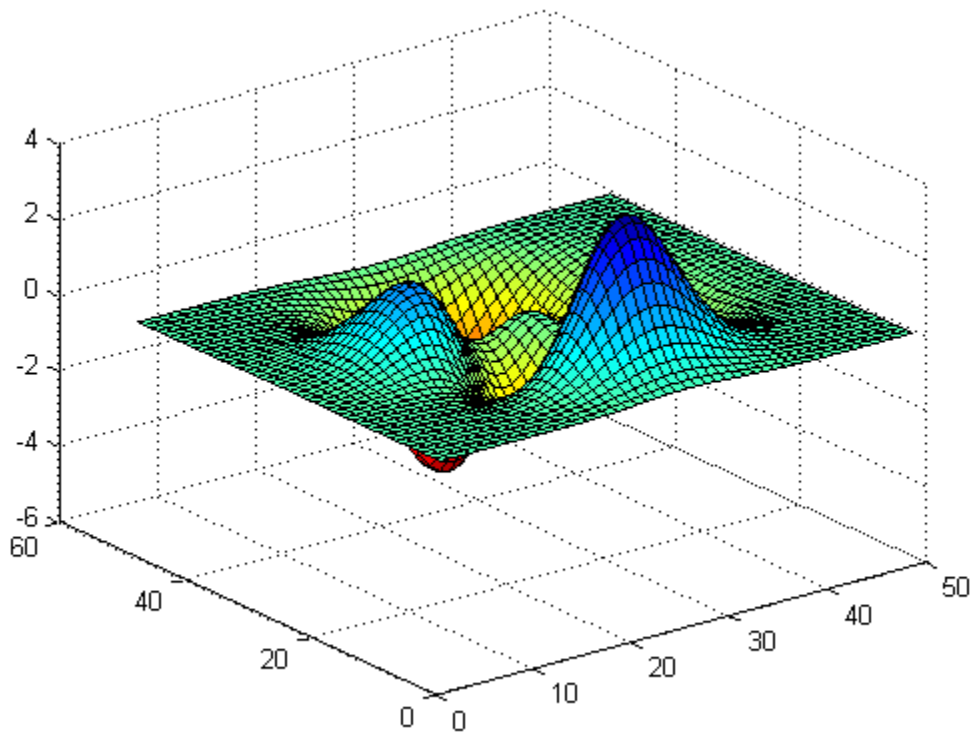

---

With larger frames, first adjust the figure's size to fit the movie:

```
figure('Position',[100 100 850 600])
```

```
Z = peaks; surf(Z);
axis tight manual
set(gca,'NextPlot','replacechildren');
% Record the movie
for j = 1:20
 surf(sin(2*pi*j/20)*Z,Z)
 F(j) = getframe;
end
% use 1st frame to get dimensions
[h, w, p] = size(F(1).cdata);
hf = figure;
% resize figure based on frame's w x h, and place at (150, 150)
set(hf,'Position', [150 150 w h]);
axis off
% Place frames at bottom left
movie(hf,F,4,30,[0 0 0 0]);
```

**See Also**

[getframe](#) | [frame2im](#) | [im2frame](#) | [VideoReader](#) | [VideoWriter](#)

**How To**

- [Example – Visualizing an FFT as a Movie](#)

# movie2avi

---

**Purpose** Create Audio/Video Interleaved (AVI) file from MATLAB movie

**Syntax** `movie2avi(mov, filename)`  
`movie2avi(mov, filename, ParameterName, ParameterValue)`

**Description** `movie2avi(mov, filename)` creates the AVI file `filename` from the MATLAB movie `mov`. The `filename` input is a string. The `mov` input is a 1-by- $n$  structure array, where  $n$  is the number of frames. Each frame is a structure with two fields: `cdata` and `colormap`. For more information, see `getframe`.

`movie2avi(mov, filename, ParameterName, ParameterValue)` accepts one or more comma-separated parameter name/value pairs. The following table lists the available parameters and values.

Parameter Name	Value	Default
'colormap'	An $m$ -by-3 matrix defining the colormap for indexed AVI movies, where $m$ is no more than 256 (236 for Indeo compression).  Valid only when the 'compression' is 'MSVC', 'RLE', or 'None'.	No default
'compression'	A text string specifying the compression codec to use. To create an uncompressed file, specify a value of 'None'.  On UNIX operating systems, the only valid value is 'None'.  On Windows systems, valid values include: <ul style="list-style-type: none"><li>• 'MSVC'</li><li>• 'RLE'</li><li>• 'Cinepak' on 32-bit systems.</li></ul>	'Indeo5' on Windows systems.  'None' on UNIX systems.

Parameter Name	Value	Default
	<ul style="list-style-type: none"> <li>'Indeo3' or 'Indeo5' on 32-bit Windows XP systems.</li> </ul> <p>Alternatively, specify a custom compression codec on Windows systems using the four-character code that identifies the codec (typically included in the codec documentation). If MATLAB cannot find the specified codec, it returns an error.</p>	
'fps'	A scalar value specifying the speed of the AVI movie in frames per second (fps).	15 fps
'keyframe'	For compressors that support temporal compression, the number of key frames per second.	2.1429 key frames per second
'quality'	A number from 0 through 100. Higher quality numbers result in higher video quality and larger file sizes. Lower quality numbers result in lower video quality and smaller file sizes.  Valid only for compressed movies.	75
'videoname'	A descriptive name for the video stream, no more than 64 characters.	<i>filename</i>

**Tips**

- On some Windows systems, including all 64-bit systems, the default Indeo 5 codec is not available. MATLAB issues a warning, and creates an uncompressed file.
- On 32-bit Windows XP systems, MATLAB can create AVI files compressed with Indeo 3 and Indeo 5 codecs. However, Microsoft Windows XP Service Pack 3 (SP3) with Security Update 954157 disables playback of Indeo 3 and Indeo 5 codecs in Windows Media Player and Internet Explorer. Consider specifying a compression value of 'None'.

## Examples

Create a movie and write to an uncompressed AVI file, `myPeaks.avi`:

```
nFrames = 20;

% Preallocate movie structure.
mov(1:nFrames) = struct('cdata', [],...
 'colormap', []);

% Create movie.
Z = peaks; surf(Z);
axis tight
set(gca, 'nextplot', 'replacechildren');
for k = 1:nFrames
 surf(sin(2*pi*k/20)*Z, Z)
 mov(k) = getframe(gcf);
end

% Create AVI file.
movie2avi(mov, 'myPeaks.avi', 'compression', 'None');
```

## See Also

[VideoWriter](#) | [VideoReader](#) | [mmfileinfo](#) | [movie](#)



**Purpose** Matrix power

**Syntax**  
 $C = A^B$   
`C = mpower(A,B)`

**Description**  $C = A^B$  computes A to the B power and returns the result in C.

$C = \text{mpower}(A,B)$  is an alternate way to execute  $A^B$ , but is rarely used. It enables operator overloading for classes.

**Input Arguments** **A - Base**  
 scalar | matrix

Base, specified as a scalar or matrix. Inputs A and B must be one of the following:

- Base A is a square matrix and exponent B is a scalar. If B is a positive integer, the power is computed by repeated squaring. For other values of B the calculation involves eigenvalues and eigenvectors.
- Base A is a scalar and exponent B is a square matrix. The calculation uses eigenvalues and eigenvectors.

**Data Types**

single | double | int8 | int16 | int32 | int64 | uint8 | uint16 | uint32 | uint64 | logical | char

**Complex Number Support:** Yes

**B - Exponent**  
 scalar | matrix

Exponent, specified as a scalar or matrix. Inputs A and B must be one of the following:

- Base A is a square matrix and exponent B is a scalar. If B is a positive integer, the power is computed by repeated squaring. For other values of B the calculation involves eigenvalues and eigenvectors.

- Base A is a scalar and exponent B is a square matrix. The calculation uses eigenvalues and eigenvectors.

## Data Types

single | double | int8 | int16 | int32 | int64 | uint8 |  
uint16 | uint32 | uint64 | logical | char

**Complex Number Support:** Yes

## Examples

### Square a Matrix

Create a 2-by-2 matrix and square it.

```
A = [1 2; 3 4];
C = A^2
```

```
C =
```

```
 7 10
 15 22
```

The syntax A^2 is equivalent to A\*A.

### Matrix Exponents

Create a 2-by-2 matrix and use it as the exponent for a scalar.

```
B = [0 1; 1 0];
C = 2^B
```

```
C =
```

```
 1.2500 0.7500
 0.7500 1.2500
```

Compute C by first finding the eigenvalues D and eigenvectors V of the matrix B.

```
[V,D] = eig(B)
```

V =

```
-0.7071 0.7071
 0.7071 0.7071
```

D =

```
-1 0
 0 1
```

Next, use the formula  $2^B = V*2^D/V$  to compute the power.

C = V\*2^D/V

C =

```
1.2500 0.7500
 0.7500 1.2500
```

**See Also**

power | mtimes | times

# FTP.mput

---

**Purpose** Upload file or folder to FTP server

**Syntax** `mput(ftpobj,contents)`  
`paths = mput(ftpobj,contents)`

**Description** `mput(ftpobj,contents)` uploads the file or folder specified by `contents` to the current folder on an FTP server.

`paths = mput(ftpobj,contents)` returns a cell array that lists the paths to the uploaded files on the server.

**Input Arguments** **ftpobj**  
FTP object created by `ftp`.

**contents**  
String enclosed in single quotation marks that specifies either a file name or a folder name. Can include a wildcard character (\*).

**Output Arguments** **paths**  
Cell array that includes the paths to the uploaded files on the server.

**Examples** Suppose that your current MATLAB folder contains files `myfile1.m` through `myfile10.m`, and that you want to upload to a hypothetical FTP server, `ftp.testsite.com`. Connect to the server and upload the files:

```
test = ftp('ftp.testsite.com');
mput(test, 'myfile*.m');
close(test);
```

**See Also** `mget` | `ftp` | `mkdir` | `rename`

<b>Purpose</b>	Create and open message dialog box
<b>Syntax</b>	<pre>h = msgbox(Message) h = msgbox(Message,Title) h = msgbox(Message,Title,Icon) h = msgbox(Message,Title,'custom',IconData,IconCMap) h = msgbox( ___,CreateMode)</pre>
<b>Description</b>	<p><code>h = msgbox(Message)</code> creates a message dialog box that automatically wraps <code>Message</code> to fit an appropriately sized figure.</p> <p><code>h = msgbox(Message,Title)</code> specifies the title of the message box.</p> <p><code>h = msgbox(Message,Title,Icon)</code> specifies which built-in icon to display in the message dialog box.</p> <p><code>h = msgbox(Message,Title,'custom',IconData,IconCMap)</code> specifies a custom icon to include in the message dialog box. <code>IconData</code> is the image data that defines the icon. <code>IconCMap</code> is the colormap used for the image. If <code>IconData</code> is a true-color image, you do not need to specify an <code>IconCMap</code>.</p> <p><code>h = msgbox( ___,CreateMode)</code> specifies whether the message box is modal. Additionally, you can specify a TeX interpreter for <code>Message</code> and <code>Title</code>.</p>
<b>Input Arguments</b>	<p><b>Message - Message dialog box text</b> string vector   string matrix   cell array</p> <p>Dialog box text specified as a string vector, string matrix, or cell array.</p> <p><b>Example:</b> 'Operation Completed'</p> <p><b>Example:</b> ['Operation ', 'Completed']</p> <p><b>Example:</b> {'Operation', 'Completed'}</p>

## **Title - Message dialog box title bar text**

string vector

Dialog box title bar text specified as a string vector.



**Example:** 'Success'

## **Icon - Icon to include in message dialog box**

'none' (default) | 'error' | 'help' | 'warn' | 'custom'

Icon to include in message dialog box specified as a string.

Built-in icons appear as follows:

-  Error
-  Help
-  Warn

## **IconData - Image data defining a custom icon**

matrix

Image data defining a custom icon specified as a matrix. Each element of the matrix specifies the color of a rectangular segment in the image. Use `imread` to get the `IconData` value for an image that you want to use as a message dialog box icon.

**Example:** `[1:64]'*[1:64])/64`

## **IconCMap - Colormap for a custom icon that is not true-color**

m-by-3 matrix | built-in colormap

Colormap for a custom icon that is not true-color, specified as a m-by-3 matrix of real numbers between 0.0 and 1.0, or as a MATLAB built-in colormap. Use `imread` to get the `IconCMap` value for an image that you want to use as a message dialog box icon.

**Example:** `[0.5 0.5 0.5]`

**Example:** `hot(64)`

**CreateMode - Message dialog box mode**

structure | 'nonmodal' (default) | 'modal' | 'replace'

Mode in which message dialog box is created, specified as a string or a structure.

- If `CreateMode` is a structure, it can have the fields `WindowStyle` and `Interpreter`. The `WindowStyle` field must be one of the strings listed in the list items that follow this one. The `Interpreter` field must be the string 'tex' or 'none'. If the `Interpreter` value is 'tex', MATLAB interprets the `Message` and `Title` values as TeX. The default value for `Interpreter` is 'none'.
- If `CreateMode` is 'nonmodal', MATLAB creates a new nonmodal message box with the specified parameters. Existing message boxes with the same `Title` remain.
- If `CreateMode` is 'modal', MATLAB replaces the existing message box with the specified `Title` that was last created or clicked on with the specified modal dialog box. MATLAB deletes all other message boxes with the same title. The replaced message box can be either modal or nonmodal.
- If `CreateMode` is 'replace', MATLAB replaces the message box having the specified `Title` that was last created or clicked on with a nonmodal message box as specified. MATLAB deletes all other message boxes with the same title. The replaced message box can be either modal or nonmodal.

**Example:** `CreateStruct.Interpreter='tex';`

**Output Arguments****h - Message dialog box handle**

scalar

Message dialog box handle returned as a scalar. This is a unique identifier, which you can use to query and modify the properties of a specific message dialog box.

## Tips

- Program execution continues even when a modal dialog box is active. To block MATLAB program execution until the user responds to the modal dialog box, use the `uiwait` function.
- If you open a dialog box with `errordlg`, `msgbox`, or `warndlg` using 'CreateMode', 'modal' and a nonmodal dialog box that was created with any of these functions is already present and *has the same title as the modal dialog box*, then the nonmodal dialog box closes when the modal one opens.

## Definitions

### modal dialog box

A modal dialog box prevents a user from interacting with other windows before responding to the modal dialog box.

For more information about modal dialog boxes, see `WindowStyle` in the `Figure Properties` topic.

## Examples

### Simple Message Dialog Box

Specify the text you want displayed in the message dialog box.

```
h = msgbox('Operation Completed');
```

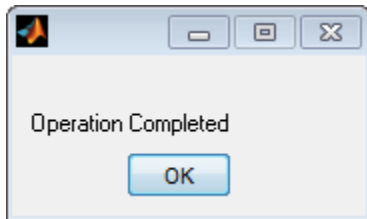

### Message Dialog Box Text with Line Breaks

Specify the message dialog box text using a cell array of strings to insert line breaks between the display of each string in the cell array.

```
h = msgbox({'Operation' 'Completed'});
```



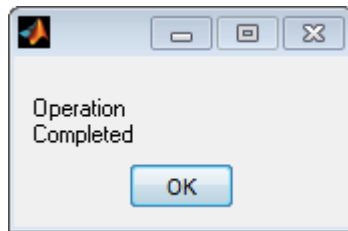

### Message Dialog Box with a Title

Specify the message dialog box text and give the dialog box a title, Success.

```
h = msgbox('Operation Completed', 'Success');
```

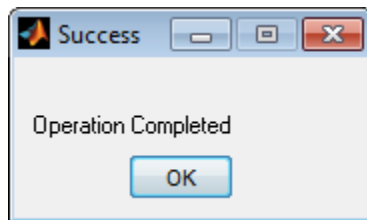

### Message Dialog Box that Uses a Built-in Icon

Include a built-in error icon with an error message in a message dialog box entitled Error.

```
h = msgbox('Invalid Value', 'Error', 'error');
```

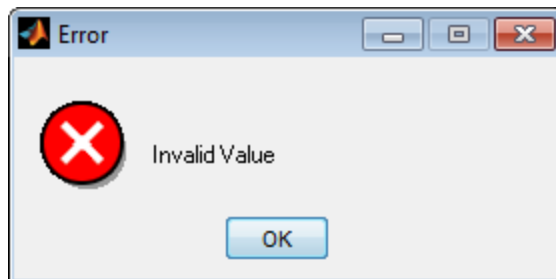

## Message Dialog Box that Uses a True-Color Custom Icon

Use a .png file as an icon in your message dialog box. True-color images, such as .png files, do not use colormaps.

Copy a .png file to a folder on your MATLAB search path.

```
copyfile(fullfile(matlabroot,...
 'help','includes','product',...
 'images','global','ico_large_info.png'));
```

Determine the value to specify for `IconData` by passing the image file to `imread`.

```
[cdata] = imread('ico_large_info.png');
```

Create the message dialog box, including the custom icon. Because .png files are true-color, you do not specify a colormap.

```
h=msgbox('Operation Completed',...
 'Success','custom',cdata);
```

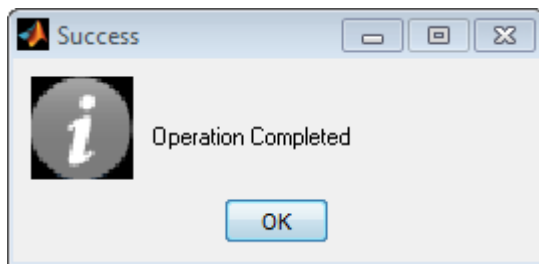

## Message Dialog Box that Uses an Indexed Custom Icon

Use `trees.tif` (which is on the MATLAB path) as an icon in your message dialog box. Because .tiff images use a colormap to define the colors, you must specify a colormap. Change the colormap to change the image colors.

Determine the value to specify for `IconData` by passing the image file to `imread`.

```
[cdata,map] = imread('trees.tif');
```

Create the message dialog box, including the custom icon.

```
h=msgbox('Operation Completed',...
 'Success','custom',cdata,map);
```

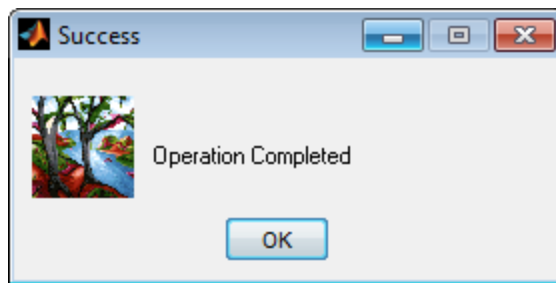

Adjust the image colors by specifying a different colormap. For instance, specify the MATLAB built-in colormap, `summer`

```
h=msgbox('Operation Completed','Success','custom',...
 cdata,summer);
```

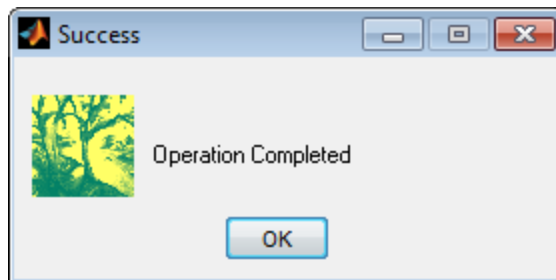

## Modal Message Dialog Box

Create a modal message dialog box, wrapping the call to `msgbox` with `uiwait` to make the message dialog box block MATLAB execution until the user responds to the message dialog box.

```
uiwait(msgbox('Operation Completed','Success','modal'));
```

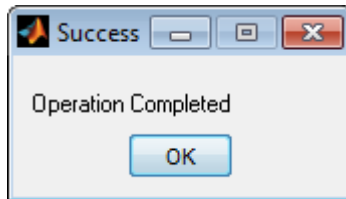

## Modal Message Dialog Box that Uses a TeX Formatted Message

Create a structure to specify that the user must click OK before interacting with another window and that MATLAB interpret the message text as TeX format.

```
CreateStruct.Interpreter = 'tex';
CreateStruct.WindowStyle = 'modal';
```

Create the message dialog box.

```
h=msgbox('Z = X^2 + Y^2','Value',CreateStruct);
```

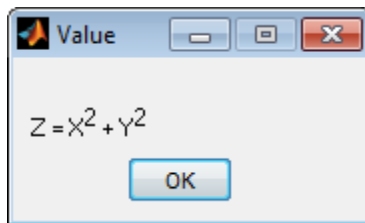

## See Also

[errordlg](#) | [helpdlg](#) | [imread](#) | [warndlg](#)

**Concepts**

- “Reading Image Data”

# mtimes, \*

---

**Purpose** Matrix Multiplication

**Syntax**  
`C = A*B`  
`C = mtimes(A,B)`

**Description** `C = A*B` is the matrix product of `A` and `B`. If `A` is an `m`-by-`p` and `B` is a `p`-by-`n` matrix, then `C` is an `m`-by-`n` matrix defined by

$$C(i,j) = \sum_{k=1}^p A(i,k)B(k,j).$$

This definition says that `C(i,j)` is the inner product of the `i`th row of `A` with the `j`th column of `B`. You can write this definition using the MATLAB colon operator as

$$C(i,j) = A(i,:) * B(:,j)$$

For nonscalar `A` and `B`, the number of columns of `A` must equal the number of rows of `B`. Matrix multiplication is *not* universally commutative for nonscalar inputs. That is, `A*B` is typically not equal to `B*A`. If at least one input is scalar, then `A*B` is equivalent to `A.*B` and is commutative.

`C = mtimes(A,B)` is an alternative way to execute `A*B`, but is rarely used. It enables operator overloading for classes.

## Input Arguments

**A - Left Array**  
scalar | vector | matrix

Left Array, specified as a scalar, vector, or matrix. For nonscalar inputs, the number of columns in `A` must be equal to the number of rows in `B`.

**Data Types**  
single | double | int8 | int16 | int32 | int64 | uint8 | uint16 | uint32 | uint64 | logical | char

**Complex Number Support:** Yes

**B - Right Array**

scalar | vector | matrix

Right Array, specified as a scalar, vector, or matrix. For nonscalar inputs, the number of columns in A must be equal to the number of rows in B.

**Data Types**

single | double | int8 | int16 | int32 | int64 | uint8 | uint16 | uint32 | uint64 | logical | char

**Complex Number Support:** Yes

**Output Arguments**

**C - Product Array**

scalar | vector | matrix

Product Array, returned as a scalar, vector, or matrix. Array C has the same number of rows as input A and the same number of columns as input B. For example, if A is an m-by-0 empty matrix and B is a 0-by-n empty matrix, then A\*B is an m-by-n matrix of zeros.

**Examples**

**Multiply Two Vectors**

Create a 1-by-4 row vector, A, and a 4-by-1 column vector, B.

```
A = [1 1 0 0];
B = [1; 2; 3; 4];
```

Multiply A times B.

```
C = A*B
```

```
C =
```

```
3
```

The result is a 1-by-1 scalar, also called the *dot product* or *inner product* of the vectors A and B. Alternatively, you can calculate the dot product  $A \cdot B$  with the syntax `dot(A,B)`.

Multiply B times A.

```
C = B*A
```

```
C =
```

```
 1 1 0 0
 2 2 0 0
 3 3 0 0
 4 4 0 0
```

The result is a 4-by-4 matrix, also called the *outer product* of the vectors A and B. The outer product of two vectors,  $A \otimes B$ , returns a matrix.

## Multiply Two Arrays

Create two arrays, A and B.

```
A = [1 3 5; 2 4 7];
```

```
B = [-5 8 11; 3 9 21; 4 0 8];
```

Calculate the product of A and B.

```
C = A*B
```

```
C =
```

```
 24 35 114
 30 52 162
```

Calculate the inner product of the second row of A and the third column of B.

```
A(2,:) * B(:,3)
```

```
ans =
```

```
 162
```



This answer is the same as  $C(2,3)$ .

**See Also**

colon | times | dot | cross

# mu2lin

---

**Purpose** Convert mu-law audio signal to linear

**Syntax** `y = mu2lin(mu)`

**Description** `y = mu2lin(mu)` converts mu-law encoded 8-bit audio signals, stored as “flints” in the range  $0 \leq \mu \leq 255$ , to linear signal amplitude in the range  $-s < Y < s$  where  $s = 32124/32768 \approx .9803$ . The input `mu` is often obtained using `fread(..., 'uchar')` to read byte-encoded audio files. “Flints” are MATLAB integers — floating-point numbers whose values are integers.

**See Also** `auread` | `lin2mu`

## Purpose

Read band-interleaved data from binary file

## Syntax

```
X = multibandread(filename, size, precision, offset, interleave,
 bytearray)
X = multibandread(...,subset1,subset2,subset3)
```

## Description

`X = multibandread(filename, size, precision, offset, interleave, bytearray)` reads band-sequential (BSQ), band-interleaved-by-line (BIL), or band-interleaved-by-pixel (BIP) data from the binary file `filename`. The `filename` input is a string enclosed in single quotes. This function defines *band* as the third dimension in a 3-D array, as shown in this figure.

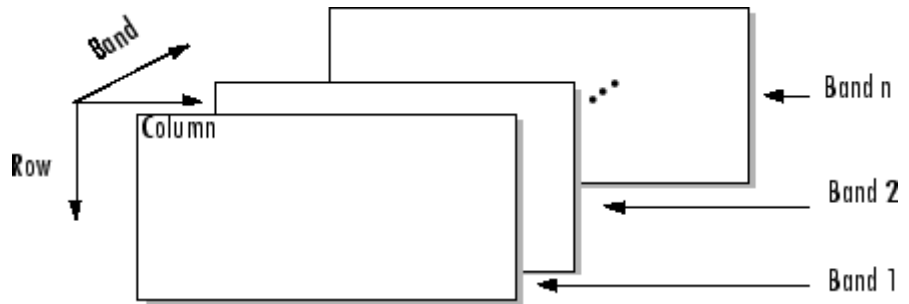

You can use the parameters to `multibandread` to specify many aspects of the read operation, such as which bands to read. See “Parameters” on page 1-4450 for more information.

`X` is a 2-D array if only one band is read; otherwise it is 3-D. `X` is returned as an array of data type `double` by default. Use the `precision` parameter to map the data to a different data type.

`X = multibandread(...,subset1,subset2,subset3)` reads a subset of the data in the file. You can use up to three subsetting parameters to specify the data subset along row, column, and band dimensions. See “Subsetting Parameters” on page 1-4451 for more information.

# multibandread

---

---

**Note** In addition to BSQ, BIL, and BIP files, multiband imagery may be stored using the TIFF file format. In that case, use the `imread` function to import the data.

---

## Parameters

This table describes the arguments accepted by `multibandread`.

Argument	Description
<code>filename</code>	String containing the name of the file to be read.
<code>size</code>	Three-element vector of integers consisting of [height, width, N], where <ul style="list-style-type: none"><li>• height is the total number of rows</li><li>• width is the total number of elements in each row</li><li>• N is the total number of bands.</li></ul> This will be the dimensions of the data if it is read in its entirety.
<code>precision</code>	String specifying the format of the data to be read, such as 'uint8', 'double', 'integer*4', or any of the other precisions supported by the <code>fread</code> function.  Note: You can also use the <code>precision</code> parameter to specify the format of the output data. For example, to read <code>uint8</code> data and output a <code>uint8</code> array, specify a precision of 'uint8=>uint8' (or '*uint8'). To read <code>uint8</code> data and output it in the MATLAB software in single precision, specify 'uint8=>single'. See <code>fread</code> for more information.

<b>Argument</b>	<b>Description</b>
offset	Scalar specifying the zero-based location of the first data element in the file. This value represents the number of bytes from the beginning of the file to where the data begins.
interleave	String specifying the format in which the data is stored <ul style="list-style-type: none"> <li>• 'bsq' — Band-Sequential</li> <li>• 'bil' — Band-Interleaved-by-Line</li> <li>• 'bip' — Band-Interleaved-by-Pixel</li> </ul> <p>For more information about these interleave methods, see the <a href="#">multibandwrite</a> reference page.</p>
byteorder	String specifying the byte ordering (machine format) in which the data is stored, such as <ul style="list-style-type: none"> <li>• 'ieee-le' — Little-endian</li> <li>• 'ieee-be' — Big-endian</li> </ul> <p>See <code>fopen</code> for a complete list of supported formats.</p>

## Subsetting Parameters

You can specify up to three subsetting parameters. Each subsetting parameter is a three-element cell array, `{dim, method, index}`, where

<b>Parameter</b>	<b>Description</b>
<i>dim</i>	Text string specifying the dimension to subset along. It can have any of these values: <ul style="list-style-type: none"> <li>• 'Column'</li> <li>• 'Row'</li> </ul>

# multibandread

---

Parameter	Description
<i>method</i>	<ul style="list-style-type: none"><li>• 'Band'</li></ul> Text string specifying the subsetting method. It can have either of these values: <ul style="list-style-type: none"><li>• 'Direct'</li><li>• 'Range'</li></ul>
<i>index</i>	If you leave out this element of the subset cell array, <code>multibandread</code> uses 'Direct' as the default. If method is 'Direct', <i>index</i> is a vector specifying the indices to read along the Band dimension. If method is 'Range', <i>index</i> is a three-element vector of [start, increment, stop] specifying the range and step size to read along the dimension specified in <i>dim</i> . If <i>index</i> is a two-element vector, <code>multibandread</code> assumes that the value of increment is 1.

## Examples

### Example 1

Setup initial parameters for a data set.

```
rows=3; cols=3; bands=5;
filename = tempname;
```

Define the data set.

```
fid = fopen(filename, 'w', 'ieee-le');
fwrite(fid, 1:rows*cols*bands, 'double');
fclose(fid);
```

Read every other band of the data using the Band-Sequential format.

```
im1 = multibandread(filename, [rows cols bands], ...
 'double', 0, 'bsq', 'ieee-le', ...
 {'Band', 'Range', [1 2 bands]})
```

Read the first two rows and columns of data using  
Band-Interleaved-by-Pixel format.

```
im2 = multibandread(filename, [rows cols bands], ...
 'double', 0, 'bip', 'ieee-le', ...
 {'Row', 'Range', [1 2]}, ...
 {'Column', 'Range', [1 2]})
```

Read the data using Band-Interleaved-by-Line format.

```
im3 = multibandread(filename, [rows cols bands], ...
 'double', 0, 'bil', 'ieee-le')
```

Delete the file created in this example.

```
delete(filename);
```

## Example 2

Read int16 BIL data from the FITS file `tst0012.fits`, starting at  
byte 74880.

```
im4 = multibandread('tst0012.fits', [31 73 5], ...
 'int16', 74880, 'bil', 'ieee-be', ...
 {'Band', 'Range', [1 3]});
im5 = double(im4)/max(max(max(im4)));
imagesc(im5);
```

## See Also

`fread` | `fwrite` | `imread` | `memmapfile` | `multibandwrite`

# multibandwrite

---

**Purpose** Write band-interleaved data to file

**Syntax** `multibandwrite(data,filename,interleave)`  
`multibandwrite(data,filename,interleave,start,totalsize)`  
`multibandwrite(...,param,value...)`

**Description** `multibandwrite(data,filename,interleave)` writes `data`, a two- or three-dimensional numeric or logical array, to the binary file specified by `filename`. The `filename` input is a string enclosed in single quotes. The length of the third dimension of `data` determines the number of bands written to the file. The bands are written to the file in the form specified by `interleave`. See “Interleave Methods” on page 1-4456 for more information about this argument.

If `filename` already exists, `multibandwrite` overwrites it unless you specify the optional `offset` parameter. See the last alternate syntax for `multibandwrite` for information about other optional parameters.

`multibandwrite(data,filename,interleave,start,totalsize)` writes `data` to the binary file `filename` in chunks. In this syntax, `data` is a subset of the complete data set.

`start` is a 1-by-3 array [`firstrow firstcolumn firstband`] that specifies the location to start writing data. `firstrow` and `firstcolumn` specify the location of the upper left image pixel. `firstband` gives the index of the first band to write. For example, `data(I,J,K)` contains the data for the pixel at [`firstrow+I-1, firstcolumn+J-1`] in the (`firstband+K-1`)-th band.

`totalsize` is a 1-by-3 array, [`totalrows,totalcolumns,totalbands`], which specifies the full, three-dimensional size of the data to be written to the file.



---

**Note** In this syntax, you must call `multibandwrite` multiple times to write all the data to the file. The first time it is called, `multibandwrite` writes the complete file, using the fill value for all values outside the data subset. In each subsequent call, `multibandwrite` overwrites these fill values with the data subset in `data`. The parameters `filename`, `interleave`, `offset`, and `totalsize` must remain constant throughout the writing of the file.

---

`multibandwrite(..., param, value...)` writes the multiband data to a file, specifying any of these optional parameter/value pairs.

Parameter	Description
'precision'	String specifying the form and size of each element written to the file. See the help for <code>fwrite</code> for a list of valid values. The default precision is the class of the data.
'offset'	The number of bytes to skip before the first data element. If the file does not already exist, <code>multibandwrite</code> writes ASCII null values to fill the space. To specify a different fill value, use the parameter <code>'fillvalue'</code> .  This option is useful when you are writing a header to the file before or after writing the data. When writing the header to the file after the data is written, open the file with <code>fopen</code> using <code>'r+'</code> permission.

# multibandwrite

Parameter	Description
'machfmt'	String to control the format in which the data is written to the file. Typical values are 'ieee-le' for little endian and 'ieee-be' for big endian. See the help for <code>fopen</code> for a complete list of available formats. The default machine format is the local machine format.
'fillvalue'	A number specifying the value to use in place of missing data. 'fillvalue' can be a single number, specifying the fill value for all missing data, or a 1-by-Number-of-bands vector of numbers specifying the fill value for each band. This value is used to fill space when data is written in chunks.

## Interleave Methods

`interleave` is a string that specifies how `multibandwrite` interleaves the bands as it writes data to the file. If data is two-dimensional, `multibandwrite` ignores the `interleave` argument. The following table lists the supported methods and uses this example multiband file to illustrate each method.

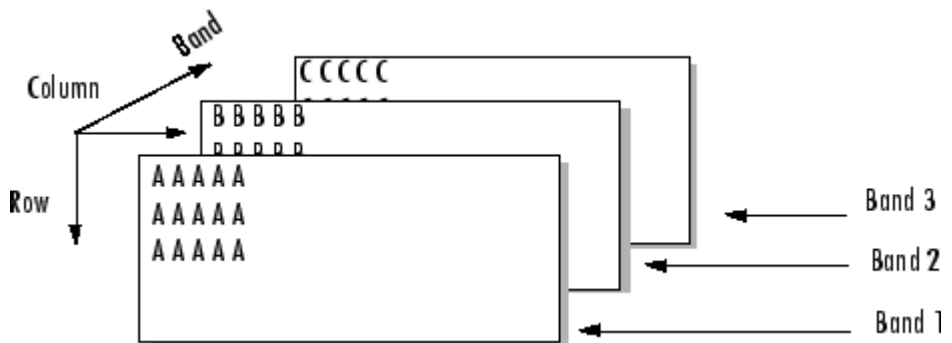

Supported methods of interleaving bands include those listed below.

Method	String	Description	Example
Band-Interleaved-by-Line	'bil'	Write an entire row from each band	AAAAABBBBBCCCCC AAAAABBBBBCCCCC AAAAABBBBBCCCCC
Band-Interleaved-by-Pixel	'bip'	Write a pixel from each band	ABCABCABCABC...
Band-Sequential	'bsq'	Write each band in its entirety	AAAAA AAAAA AAAAA BBBBB BBBBB BBBBB CCCCC CCCCC CCCCC

## Examples

---

**Note** To run these examples successfully, you must be in a writable directory.

---

### Example 1

Write all data (interleaved by line) to the file in one call.

```
data = reshape(uint16(1:600), [10 20 3]);
multibandwrite(data, 'data.bil', 'bil');
```

# multibandwrite

---

## Example 2

Write a single-band tiled image with one call for each tile. This is only useful if a subset of each band is available at each call to `multibandwrite`.

```
numBands = 1;
dataDims = [1024 1024 numBands];
data = reshape(uint32(1:(1024 * 1024 * numBands)), dataDims);

for band = 1:numBands
 for row = 1:2
 for col = 1:2

 subsetRows = ((row - 1) * 512 + 1):(row * 512);
 subsetCols = ((col - 1) * 512 + 1):(col * 512);

 upperLeft = [subsetRows(1), subsetCols(1), band];
 multibandwrite(data(subsetRows, subsetCols, band), ...
 'banddata.bsq', 'bsq', upperLeft, dataDims);

 end
 end
end
```

## See Also

`multibandread` | `fwrite` | `fread`

**Purpose** Allow clearing functions from memory

**Syntax**

```
munlock
munlock fun
munlock('fun')
```

**Description** `munlock` unlocks the currently running `.m` or `.mex` function in memory so that subsequent `clear` functions can remove it.

`munlock fun` unlocks the `.m` or `.mex` file named `fun` from memory. By default, these files are unlocked so that changes to the file are picked up. Calls to `munlock` are needed only to unlock `.m` or `.mex` functions that have been locked with `mlock`.

`munlock('fun')` is the function form of `munlock`.

**Examples** The function `testfun` begins with an `mlock` statement.

```
function testfun
mlock
.
.
```

When you execute this function, it becomes locked in memory. You can check this using the `mislocked` function.

```
testfun

mislocked testfun
ans =
 1
```

Using `munlock`, you unlock the `testfun` function in memory. Checking its status with `mislocked` shows that it is indeed unlocked at this point.

```
munlock testfun

mislocked testfun
ans =
```

# **munlock**

---

0

## **See Also**

`mlock` | `mislocked` | `inmem` | `persistent`

**Purpose** Maximum identifier length

**Syntax** `len = namelengthmax`

**Description** `len = namelengthmax` returns the maximum length allowed for MATLAB identifiers, which include:

- Variable names
- Structure field names
- Script, function, and class names
- Model names

Rather than hard-coding a specific maximum name length into your programs, use the `namelengthmax` function. This saves you the trouble of having to update these limits should the identifier length change in some future MATLAB release.

**Examples** Call `namelengthmax` to get the maximum identifier length:

```
maxid = namelengthmax
maxid =
 63
```

**See Also** `isvarname` | `matlab.lang.makeValidName` | `matlab.lang.makeUniqueStrings`

# NaN

---

## Purpose

Not-a-Number

## Syntax

```
NaN
N = NaN(n)
N = NaN(sz1, ..., szN)
N = NaN(sz)

N = NaN(classname)
N = NaN(n, classname)
N = NaN(sz1, ..., szN, classname)
N = NaN(sz, classname)

N = NaN('like', p)
N = NaN(n, 'like', p)
N = NaN(sz1, ..., szN, 'like', p)
N = NaN(sz, 'like', p)
```

## Description

NaN returns the IEEE arithmetic representation for Not-a-Number (NaN). These values result from operations which have undefined numerical results.

$N = \text{NaN}(n)$  is an  $n$ -by- $n$  matrix of NaN values.

$N = \text{NaN}(sz1, \dots, szN)$  is a  $sz1$ -by-...-by- $szN$  array of NaN values where  $sz1, \dots, szN$  indicates the size of each dimension. For example,  $\text{NaN}(3, 4)$  returns a 3-by-4 array of NaN values.

$N = \text{NaN}(sz)$  is an array of NaN values where the size vector,  $sz$ , defines  $\text{size}(N)$ . For example,  $\text{NaN}([3, 4])$  returns a 3-by-4 array of NaN values.

---

**Note** The size inputs  $sz1, \dots, szN$ , as well as the elements of the size vector  $sz$ , should be nonnegative integers. Negative integers are treated as 0.

---



`N = NaN(classname)` returns a NaN value where the string, `classname`, specifies the data type. `classname` can be either 'single' or 'double'.

`N = NaN(n,classname)` returns an n-by-n array of NaN values of data type `classname`.

`N = NaN(sz1,...szN,classname)` returns a sz1-by-...-by-szN array of NaN values of data type `classname`.

`N = NaN(sz,classname)` returns an array of NaN values where the size vector, `sz`, defines `size(N)` and `classname` defines `class(N)`.

`N = NaN('like',p)` returns a NaN value of the same data type, sparsity, and complexity (real or complex) as the numeric variable, `p`.

`N = NaN(n,'like',p)` returns an n-by-n array of NaN values like `p`.

`N = NaN(sz1,...szN,'like',p)` returns a sz1-by-...-by-szN array of NaN values like `p`.

`N = NaN(sz,'like',p)` returns an array of NaN values like `p` where the size vector, `sz`, defines `size(N)`.

## Examples

These operations produce NaN:

- Any arithmetic operation on a NaN, such as `sqrt(NaN)`
- Addition or subtraction, such as magnitude subtraction of infinities as `(+Inf)+(-Inf)`
- Multiplication, such as `0*Inf`
- Division, such as `0/0` and `Inf/Inf`
- Remainder, such as `rem(x,y)` where `y` is zero or `x` is infinity

# NaN

---

## Tips

Because two NaNs are not equal to each other, logical operations involving NaNs always return false, except `~=` (not equal). Consequently,

```
NaN ~= NaN
ans =
 1
NaN == NaN
ans =
 0
```

and the NaNs in a vector are treated as different unique elements.

```
unique([1 1 NaN NaN])
ans =
 1 NaN NaN
```

Use the `isnan` function to detect NaNs in an array.

```
isnan([1 1 NaN NaN])
ans =
 0 0 1 1
```

## See Also

`inf` | `isnan` | `isfinite` | `isfloat`

## Concepts

- “Class Support for Array-Creation Functions”

**Purpose**

Validate number of input arguments

---

**Note** nargchk will be removed in a future version. Use narginchk instead.

---

**Syntax**

```
msgstring = nargchk(minargs, maxargs, numargs)
msgstring = nargchk(minargs, maxargs, numargs, 'string')
msgstruct = nargchk(minargs, maxargs, numargs, 'struct')
```

**Description**

Use nargchk inside a function to check that the desired number of input arguments is specified in the call to that function.

msgstring = nargchk(minargs, maxargs, numargs) returns an error message string msgstring if the number of inputs specified in the call numargs is less than minargs or greater than maxargs. If numargs is between minargs and maxargs (inclusive), nargchk returns an empty matrix.

It is common to use the nargin function to determine the number of input arguments specified in the call.

msgstring = nargchk(minargs, maxargs, numargs, 'string') is essentially the same as the command shown above, as nargchk returns a string by default.

msgstruct = nargchk(minargs, maxargs, numargs, 'struct') returns an error message structure msgstruct instead of a string. The fields of the return structure contain the error message string and a message identifier. If numargs is between minargs and maxargs (inclusive), nargchk returns an empty structure.

When too few inputs are supplied, the message string and identifier are

```
message: 'Not enough input arguments.'
identifier: 'MATLAB:nargchk:notEnoughInputs'
```

When too many inputs are supplied, the message string and identifier are

# nargchk

---

```
message: 'Too many input arguments.'
identifier: 'MATLAB:nargchk:tooManyInputs'
```

## Tips

nargchk is often used together with the error function. The error function accepts either type of return value from nargchk: a message string or message structure. For example, this command provides the error function with a message string and identifier regarding which error was caught:

```
error(nargchk(2, 4, nargin, 'struct'))
```

If nargchk detects no error, it returns an empty string or structure. When nargchk is used with the error function, as shown here, this empty string or structure is passed as an input to error. When error receives an empty string or structure, it simply returns and no error is generated.

## Examples

Given the function CheckInputs,

```
function CheckInputs(x, y, z)
error(nargchk(2, 3, nargin))
```

Then typing CheckInputs(1) produces

```
Not enough input arguments.
```

## See Also

```
narginchk | nargoutchk | nargin | nargout | varargin | varargout
| error
```

**Purpose** Number of function input arguments

**Syntax** nargin  
nargin(fx)

**Description** nargin returns the number of input arguments passed in the call to the currently executing function. Use this nargin syntax only in the body of a function.

nargin(fx) returns the number of input arguments that appear in the definition statement for function fx. If the function includes varargin in its definition, then nargin returns the negative of the number of inputs. For example, if function foo declares inputs a, b, and varargin, then nargin('foo') returns -3.

**Input Arguments** **fx**  
Either a function handle or a string in single quotes that specifies the name of a function.

## **Examples** **Inputs to Current Function**

Create a function in a file named addme.m that accepts up to two inputs, and identify the number of inputs with nargin.

```
function c = addme(a,b)
```

```
switch nargin
 case 2
 c = a + b;
 case 1
 c = a + a;
 otherwise
 c = 0;
end
```

## **Inputs Defined for a Function**

Determine how many inputs a function can accept.

# nargin

---

The function `addme` created in the previous example has two inputs in its declaration statement (`a` and `b`).

```
fx = 'addme';
nargin(fx)
```

```
ans =
 2
```

## Function with varargin Input

Determine how many inputs a function that uses `varargin` can accept.

Define a function in a file named `mynewplot.m` that accepts numeric inputs `x` and `y` and any number of additional plot inputs using `varargin`.

```
function mynewplot(x,y,varargin)
 figure
 plot(x,y,varargin{:})
 title('My New Plot')
```

At the command line, query how many inputs `newplot` can accept.

```
fx = 'mynewplot';
nargin(fx)
```

```
ans =
 -3
```

The minus sign indicates that the third input is `varargin`. The `mynewplot` function can accept an indeterminate number of additional input arguments.

## See Also

`nargout` | `narginchk` | `nargoutchk` | `varargin` | `varargout` | `inputname`

<b>Purpose</b>	Validate number of input arguments
<b>Syntax</b>	<code>narginchk(minargs, maxargs)</code>
<b>Description</b>	<p><code>narginchk(minargs, maxargs)</code> throws an error if the number of inputs specified in the call to the currently executing function is less than <code>minargs</code> or greater than <code>maxargs</code>. If the number of inputs is between <code>minargs</code> and <code>maxargs</code> (inclusive), <code>narginchk</code> does nothing.</p> <p>When too few inputs are supplied, the message identifier and message are:</p> <pre>identifier: 'MATLAB:narginchk:notEnoughInputs' message: 'Not enough input arguments.'</pre> <p>When too many inputs are supplied, the message identifier and message are:</p> <pre>identifier: 'MATLAB:narginchk:tooManyInputs' message: 'Too many input arguments.'</pre> <ul style="list-style-type: none"><li>• To verify that there are a minimum of <code>N</code> arguments, specify <code>inf</code> as <code>maxargs</code>. For example: <code>narginchk(5,inf)</code> throws an error when there are not at least five inputs.</li></ul>
<b>Examples</b>	<p>This function uses <code>narginchk</code> to verify that a minimum of 2 and maximum of 5 input arguments are received from the calling function:</p> <pre>function check_inputs(A, B, varargin) minargs=2; maxargs=5;  % Number of inputs must be &gt;=minargs and &lt;=maxargs. narginchk(minargs, maxargs)  fprintf('Received 2 required, %d optional inputs.\n\n', ... size(varargin, 2))</pre>

# narginchk

---

Call the example function, passing 1 input argument:

```
check_inputs(23)
Error using check_inputs
Not enough input arguments.
```

Call the function, passing 5 arguments:

```
check_inputs(23, 9, 15, 34, 62)
Received 2 required, 3 optional inputs.
```

Call the function, passing 6 arguments:

```
check_inputs(23, 9, 15, 34, 62, 6)
Error using check_inputs
Too many input arguments.
```

## See Also

nargoutchk | nargin | nargout | varargin | varargout



<b>Purpose</b>	Number of function output arguments
<b>Syntax</b>	nargout nargout(fx)
<b>Description</b>	<p>nargout returns the number of output arguments specified in the call to the currently executing function. Use this nargout syntax only in the body of a function.</p> <p>nargout(fx) returns the number of outputs that appear in the definition statement of function fx. If the function includes varargout in its definition, then nargout returns the negative of the number of outputs. For example, if function foo declares outputs a, b, and varargout, then nargout('foo') returns -3.</p>
<b>Input Arguments</b>	<p><b>fx</b></p> <p>Either a function handle or a string in single quotes that specifies the name of a function.</p>
<b>Examples</b>	<p><b>Outputs for Current Function</b></p> <p>Create a function in a file named <code>subtract.m</code> that calculates a second return value only when requested.</p> <pre>function [dif,absdif] = subtract(y,x) dif = y - x; if nargout &gt; 1     disp('Calculating absolute value')     absdif = abs(dif); end</pre> <p><b>Outputs Defined for a Function</b></p> <p>Determine how many outputs a function can return.</p> <p>The function named <code>subtract</code> created in the previous example has two outputs in its declaration statement (<code>dif</code> and <code>absdif</code>).</p>

```
fx = 'subtract';
nargout(fx)
```

```
ans =
 2
```

## Function with varargout Output

Determine how many outputs a function that uses `varargout` can return.

Define a function in a file named `mysize.m` that returns a vector of dimensions from the `size` function and the individual dimensions using `varargout`.

```
function [sizeVector,varargout] = mysize(x)
 sizeVector = size(x);
 varargout = cell(1,nargout-1);
 for k = 1:length(varargout)
 varargout{k} = sizeVector(k);
 end
```

At the command line, query how many outputs `mysize` can return.

```
fx = 'mysize';
nargout(fx)
```

```
ans =
 -2
```

The minus sign indicates that the second output is `varargout`. The `mysize` function can return an indeterminate number of additional outputs.

## Tips

- When you use a function as part of an expression, MATLAB calls the function with one output argument, so `nargout` within the function returns 1. For example, given the following `if` statement and the `subtract` function defined in the Examples section, the value of `nargout` within the `subtract` function is 1.

```
a = 1; b = 2;
if subtract(a,b) < 0
 disp('Result is negative')
end
```

## See Also

[nargin](#) | [nargoutchk](#) | [narginchk](#) | [varargout](#) | [varargin](#) | [inputname](#)

# nargoutchk

---

**Purpose** Validate number of output arguments

**Syntax** `nargoutchk(minargs, maxargs)`

**Description** `nargoutchk(minargs, maxargs)` throws an error if the number of outputs specified in the call is less than `minargs` or greater than `maxargs`. If the number of outputs is between `minargs` and `maxargs` (inclusive), `nargoutchk` does nothing.

When too few outputs are supplied, the identifier and message are:

```
identifier: 'MATLAB:nargoutchk:notEnoughOutputs'
message: 'Not enough output arguments.'
```

When too many outputs are supplied, the identifier and message are:

```
identifier: 'MATLAB:nargoutchk:tooManyOutputs'
message: 'Too many output arguments.'
```

**Tips**

- To verify that there are a minimum of `N` arguments, specify `inf` as `maxargs`. For example: `nargoutchk(5,inf)` throws an error when there are not at least five outputs.

**Examples** This function uses `nargoutchk` to verify that a minimum of 2 and maximum of 5 input arguments are passed back to the calling function:

```
function [varargout] = check_outputs(array_in)
minargs=2; maxargs=5;

% Number of outputs must be >=minargs and <=maxargs.
nargoutchk(minargs, maxargs)

for k=1:nargout
 varargout{k} = array_in(k)*3;
end
```

Initialize input array `X` to a vector of 6 elements:

```
X = 5:7:40
X =
 5 12 19 26 33 40
```

Call the example function with 1 output argument. This is less than the minimum (2) that was specified by nargoutchk and results in an error:

```
A = check_outputs(X);
```

```
Error using check_outputs
Not enough output arguments.
```

Call the function with 4 output arguments. This is within the allowable bounds (2 to 5) specified by nargoutchk:

```
[A, B, C, D] = check_outputs(X);
```

```
[A, B, C, D]
ans =
 15 36 57 78
```

Call the function with 6 output arguments. This exceeds the maximum (5) that was specified by nargoutchk and results in an error:

```
[A, B, C, D, E, F] = check_outputs(X);
```

```
Error using check_outputs
Too many output arguments.
```

## See Also

narginchk | nargout | nargin | varargout | varargin

# native2unicode

---

**Purpose** Convert numeric bytes to Unicode character representation

**Syntax** `unicodestr = native2unicode(bytes)`  
`unicodestr = native2unicode(bytes, encoding)`

**Description** `unicodestr = native2unicode(bytes)` converts a numeric vector, `bytes`, from the user default encoding to Unicode character representation. `bytes` is treated as a stream of 8-bit bytes, and each value must be in the range [0,255]. Return value `unicodestr` is a char vector having the same general array shape as `bytes`.

`unicodestr = native2unicode(bytes, encoding)` converts `bytes` to Unicode representation assuming that the byte stream is in the character encoding scheme specified by the string `encoding`. `encoding` must be the empty string ('') or a name or alias for an encoding scheme. Some examples are 'UTF-8', 'latin1', 'US-ASCII', and 'Shift\_JIS'. If `encoding` is unspecified or is the empty string (''), the default encoding scheme is used.

---

**Note** If `bytes` is a char vector, it is returned unchanged.

---

**Examples** This example begins with a vector of bytes in an unknown character encoding scheme. The user-written function `detect_encoding` determines the encoding scheme. If successful, it returns the encoding scheme name or alias as a string. If unsuccessful, it throws an error represented by an `MException` object, `ME`. The example calls `native2unicode` to convert the bytes to Unicode representation:

```
try
 enc = detect_encoding(bytes);
 str = native2unicode(bytes, enc);
 disp(str);
catch ME
 rethrow(ME);
end
```

Note that the computer must be configured to display text in a language represented by the detected encoding scheme for the output of `disp(str)` to be correct.

## See Also

`unicode2native`

# nchoosek

---

## Purpose

Binomial coefficient or all combinations

## Syntax

`b = nchoosek(n,k)`  
`C = nchoosek(v,k)`

## Description

`b = nchoosek(n,k)` returns the binomial coefficient, defined as  $n!/((n-k)! k!)$ . This is the number of combinations of  $n$  items taken  $k$  at a time.

`C = nchoosek(v,k)` returns a matrix containing all possible combinations of the elements of vector  $v$  taken  $k$  at a time. Matrix  $C$  has  $k$  columns and  $n!/((n-k)! k!)$  rows, where  $n$  is `length(v)`.

## Input Arguments

### **n - Number of possible choices**

scalar, real, nonnegative value

Number of possible choices, specified as a scalar value of any numeric type that is real and nonnegative.

**Example:** 10

**Example:** `int16(10)`

### **Data Types**

single | double | int8 | int16 | int32 | int64 | uint8 |  
uint16 | uint32 | uint64

### **k - Number of selected choices**

scalar, real, nonnegative value

Number of selected choices, specified as a scalar value that is real and nonnegative.  $k$  can be any numeric type. However, `nchoosek(n,k)` requires that  $n$  and  $k$  be the same type or that at least one of them be of type double.

There are no restrictions on combining inputs of different types for `nchoosek(v,k)`.

**Example:** 3



**Example:** `int16(3)`

**Data Types**

`single | double | int8 | int16 | int32 | int64 | uint8 | uint16 | uint32 | uint64`

**v - Set of all choices**

vector of numeric, logical, or char values

Set of all choices, specified as a vector of numeric, logical, or char values.

**Example:** `[1 2 3 4 5]`

**Example:** `[1+1i 2+1i 3+1i 4+1i]`

**Example:** `int16([1 2 3 4 5])`

**Example:** `[true false true false]`

**Example:** `['abcd']`

**Data Types**

`single | double | int8 | int16 | int32 | int64 | uint8 | uint16 | uint32 | uint64 | logical | char`

**Complex Number Support:** Yes

**Output Arguments**

**b - Binomial coefficient**

nonnegative scalar value

Binomial coefficient, returned as a nonnegative scalar value. `b` is the same type as `n` and `k`. If `n` and `k` are of different types, then `b` is returned as the `nondouble` type.

**C - All combinations of v**

matrix

All combinations of `v`, returned as a matrix of the same type as `v`. Matrix `C` has `k` columns and  $n!/((n-k)! k!)$  rows, where `n` is `length(v)`.

Each row of **C** contains a combination of *k* items chosen from *v*. The elements in each row of **C** are listed in the same order as they appear in *v*.

## Limitations

- When  $b = \text{nchoosek}(n, k)$  is sufficiently large, `nchoosek` displays a warning that the result might not be exact. In this case, the result is only accurate to 15 digits for double-precision inputs, or 8 digits for single-precision inputs.
- $C = \text{nchoosek}(v, k)$  is only practical for situations where  $\text{length}(v)$  is less than about 15.

## Examples

### Binomial Coefficient, "5 Choose 4"

```
b = nchoosek(5,4)
```

```
b =
```

```
5
```

### All Combinations of Five Numbers Taken Four at a Time

```
v = 2:2:10;
```

```
C = nchoosek(v,4)
```

```
C =
```

```
2 4 6 8
2 4 6 10
2 4 8 10
2 6 8 10
4 6 8 10
```

### All Combinations of Three Unsigned Integers Taken Two at a Time

```
v = uint16([10 20 30]);
```

```
C = nchoosek(v,uint16(2))
```

C =

10	20
10	30
20	30

**See Also**

perms

# ndgrid

---

<b>Purpose</b>	Rectangular grid in N-D space
<b>Syntax</b>	$[X1, X2, X3, \dots, Xn] = \text{ndgrid}(x1gv, x2gv, x3gv, \dots, xngv)$ $[X1, X2, \dots, Xn] = \text{ndgrid}(xgv)$
<b>Description</b>	<p><math>[X1, X2, X3, \dots, Xn] = \text{ndgrid}(x1gv, x2gv, x3gv, \dots, xngv)</math> replicates the grid vectors <math>x1gv, x2gv, x3gv, \dots, xngv</math> to produce a full grid. This grid is represented by the output coordinate arrays <math>X1, X2, X3, \dots, Xn</math>. The <math>i</math>th dimension of any output array <math>Xi</math> contains copies of the grid vector <math>xigv</math>.</p> <p><math>[X1, X2, \dots, Xn] = \text{ndgrid}(xgv)</math> is the same as <math>[X1, X2, \dots, Xn] = \text{ndgrid}(xgv, xgv, \dots, xgv)</math>. In other words, you can reuse the same grid vector in each respective dimension. The dimensionality of the output arrays is determined by the number of output arguments.</p> <p>The coordinate arrays <math>[X1, X2, X3, \dots, Xn]</math> are typically used to evaluate functions of several variables and to create surface and volumetric plots.</p>
<b>Input Arguments</b>	<p><b>xigv</b> Grid vector specifying a series of grid point coordinates in the <math>i</math>th dimension.</p> <p><b>xgv</b> Generic grid vector specifying a series of point coordinates.</p>
<b>Output Arguments</b>	<p><b>Xi</b> The <math>i</math>th dimension of the output array <math>Xi</math> are copies of elements of the grid vector <math>xigv</math>. The output arrays specify the full grid.</p>
<b>Tips</b>	The <code>ndgrid</code> function is similar to <code>meshgrid</code> , however <code>ndgrid</code> supports 1-D to N-D while <code>meshgrid</code> is restricted to 2-D and 3-D. The coordinates output by each function are the same, but the shape of the output arrays in the first two dimensions are different. For grid vectors $x1gv$ ,

$x2gv$  and  $x3gv$  of length  $M$ ,  $N$  and  $P$  respectively, `ndgrid(x1gv, x2gv)` will output arrays of size  $M$ -by- $N$  while `meshgrid(x1gv, x2gv)` outputs arrays of size  $N$ -by- $M$ . Similarly, `ndgrid(x1gv, x2gv, x3gv)` will output arrays of size  $M$ -by- $N$ -by- $P$  while `meshgrid(x1gv, x2gv, x3gv)` outputs arrays of size  $N$ -by- $M$ -by- $P$ . See “Grid Representation” in the MATLAB Mathematics documentation for more information.

## Examples

### Evaluate Function Over Gridded Domain

Evaluate the function  $x_1 e^{-x_1^2 - x_2^2}$  over the gridded domain  $-2 < x_1 < 2$  and  $-2 < x_2 < 2$ .

Create a grid of values for the domain.

```
[X1,X2] = ndgrid(-2:.2:2, -2:.2:2);
```

Evaluate the function over the domain.

```
Z = X1 .* exp(-X1.^2 - X2.^2);
```

Generate a mesh plot of the function.

```
mesh(X1,X2,Z)
```

# ndgrid

---

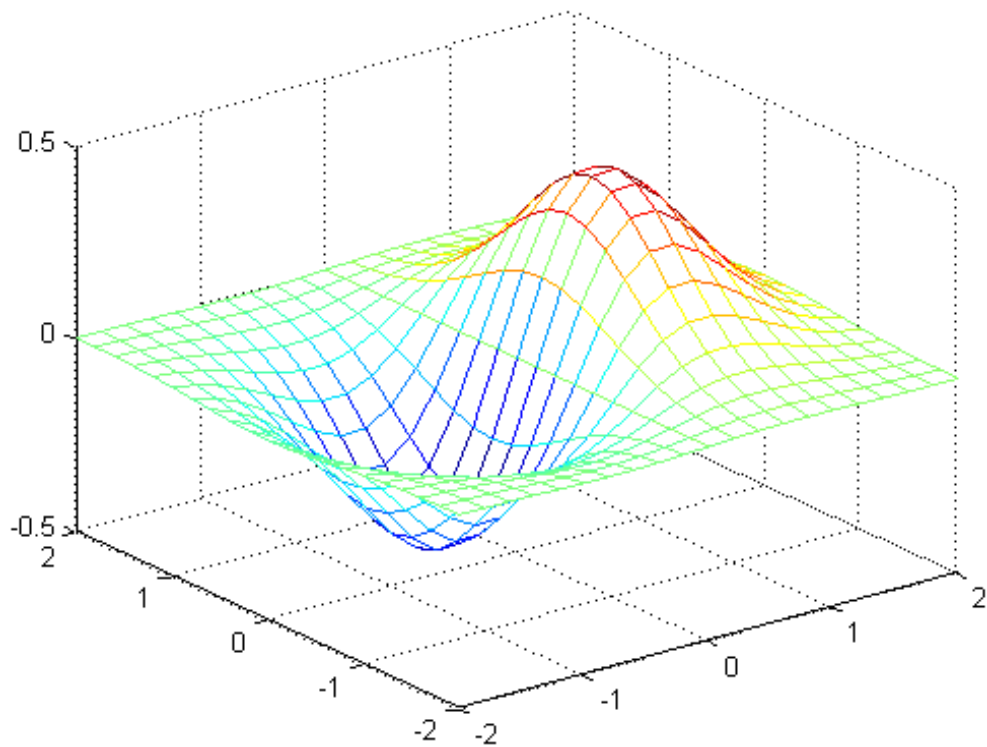

## See Also

[griddedInterpolant](#) | [meshgrid](#) | [mesh](#) | [surf](#)

## How To

- “Interpolating Gridded Data”

<b>Purpose</b>	Number of array dimensions
<b>Syntax</b>	<code>N = ndims(A)</code>
<b>Description</b>	<code>N = ndims(A)</code> returns the number of dimensions in the array <code>A</code> . The number of dimensions is always greater than or equal to 2. The function ignores trailing singleton dimensions, for which <code>size(A,dim) = 1</code> .
<b>Input Arguments</b>	<b>A - Input array</b> scalar   vector   matrix   multidimensional array  Input array, specified as a scalar, vector, matrix, or multidimensional array. This includes numeric arrays, logical arrays, character arrays, categorical arrays, tables, structure arrays, cell arrays, and object arrays.
<b>Examples</b>	<b>Find Dimensions of Vector</b>  Create a row vector.  <code>A = 1:5;</code>  Find the number of dimensions in the vector.  <code>ndims(A)</code>  <code>ans =</code>  2  The result is 2 because the vector has a size of 1-by-5.  <b>Find Dimensions of Cell Array</b>  Create a cell array of strings.  <code>C{1,1,1} = 'cell_1';</code> <code>C{1,1,2} = 'cell_2';</code> <code>C{1,1,3} = 'cell_3'</code>

# ndims

---

```
C(:,:,1) =
 'cell_1'
```

```
C(:,:,2) =
 'cell_2'
```

```
C(:,:,3) =
 'cell_3'
```

Find the number of dimensions of the cell array.

```
ndims(A)
```

```
ans =
```

```
 3
```

The result is 3 because the cell array has a size of 1-by-1-by-3.

## Algorithms

The number of dimensions in an array is the same as the length of the size vector of the array. In other words, `ndims(A) = length(size(A))`.

## See Also

[size](#) | [length](#)



<b>Purpose</b>	Determine inequality
<b>Syntax</b>	A ~= B ne(A,B)
<b>Description</b>	<p>A ~= B returns a logical array with elements set to logical 1 (true) where arrays A and B are not equal; otherwise, it returns logical 0 (false). The test compares both real and imaginary parts of numeric arrays. ne returns logical 1 (true) where A or B have NaN or undefined categorical elements.</p> <p>ne(A,B) is an alternative way to execute A ~= B, but is rarely used. It enables operator overloading for classes.</p>
<b>Input Arguments</b>	<p><b>A - Left array</b> numeric array   logical array   character array   categorical array</p> <p>Left array, specified as a numeric array, logical array, character array, or categorical array. Inputs A and B must be the same size unless one is a scalar. A scalar input expands into an array of the same size as the other input.</p> <p>If one input is a categorical array, the other input can be a categorical array, a cell array of strings, or a single string. A single string expands into a cell array of strings of the same size as the other input. If both inputs are ordinal categorical arrays, they must have the same sets of categories, including their order. If both inputs are categorical arrays that are not ordinal, they can have different sets of categories. See “Compare Categorical Array Elements” for more details.</p> <p><b>Data Types</b> single   double   int8   int16   int32   int64   uint8   uint16   uint32   uint64   logical   char</p> <p><b>Complex Number Support:</b> Yes</p> <p><b>B - Right array</b> numeric array   logical array   character array   categorical array</p>

Right array, specified as a numeric array, logical array, character array, or categorical array. Inputs **A** and **B** must be the same size unless one is a scalar. A scalar input expands into an array of the same size as the other input.

If one input is a categorical array, the other input can be a categorical array, a cell array of strings, or a single string. A single string expands into a cell array of strings of the same size as the other input. If both inputs are ordinal categorical arrays, they must have the same sets of categories, including their order. If both inputs are categorical arrays that are not ordinal, they can have different sets of categories. See “Compare Categorical Array Elements” for more details.

**Data Types**

single | double | int8 | int16 | int32 | int64 | uint8 |  
uint16 | uint32 | uint64 | logical | char

**Complex Number Support:** Yes

**Examples****Inequality of Two Vectors**

Create two vectors containing both real and imaginary numbers.

```
A = [1+i 3 2 4+i];
```

```
B = [1 3+i 2 4+i];
```

Compare the two vectors for inequality.

```
A ~= B
```

```
ans =
```

```
 1 1 0 0
```

The `ne` function tests both real and imaginary parts for inequality, and returns logical 1 (true) where one or both parts are not equal.

**Find Characters in String**

Create a string of characters.

```
M = 'masterpiece';
```

Test the string for the presence of a specific character using ~=.

```
M ~= 'n'
```

```
ans =
```

```
 1 1 1 1 1 1 1 1 1 1 1
```

The value of logical 1 (true) in the vector indicates the absence of the character 'n'. The character is not present in the string.

### Find Values in Categorical Array

Create a categorical array.

```
A = categorical({'heads' 'heads' 'tails'; 'tails' 'heads' 'tails'})
```

```
A =
```

```
 heads heads tails
 tails heads tails
```

The array has two categories: 'heads' and 'tails'.

Find all values not in the 'heads' category.

```
A ~= 'heads'
```

```
ans =
```

```
 0 0 1
 1 0 1
```

A value of logical 1 (true) indicates a value not in the category. Since A only has two categories, A ~= 'heads' returns the same answer as A == 'tails'.

Compare the rows of A for inequality.

```
A(1,:) ~= A(2, :)
```

```
ans =
```

```
 1 0 0
```

The function returns logical 1 (true) where the rows have unequal category values.

### **Compare Floating-Point Numbers**

Some floating-point numbers cannot be represented exactly in binary form. This leads to small differences in results that the ~= operator reflects.

Perform a few subtraction operations on a floating-point number and store the result in **C**.

```
C = 0.5-0.4-0.1
```

```
C =
```

```
-2.7756e-17
```

Intuitively, **C** should be equal to *exactly* 0. Its small value is due to the nature of floating-point arithmetic.

Compare **C** to zero for inequality.

```
C ~= 0
```

```
ans =
```

```
 1
```

The result is logical 1 (true).

Compare floating-point numbers using a tolerance, **tol**, instead of ~=.

```
tol = eps;
```

```
abs(C-0) > tol
```

```
ans =
```

```
0
```

The two numbers, `C` and `0`, are closer to one another than two consecutive floating-point numbers. They are essentially equal.

**See Also**

`ge` | `gt` | `le` | `lt` | `eq`

# DelaunayTri.nearestNeighbor

---

## Purpose

(Will be removed) Point closest to specified location

---

**Note** `nearestNeighbor(DelaunayTri)` will be removed in a future release. Use `nearestNeighbor(delaunayTriangulation)` instead.

`DelaunayTri` will be removed in a future release. Use `delaunayTriangulation` instead.

---

## Syntax

```
PI = nearestNeighbor(DT,QX)
PI = nearestNeighbor(DT,QX,QY)
PI = nearestNeighbor(DT,QX,QY,QZ)
[PI,D] = nearestNeighbor(DT,QX,...)
```

## Description

`PI = nearestNeighbor(DT,QX)` returns the index of the nearest point in `DT.X` for each query point location in `QX`.

`PI = nearestNeighbor(DT,QX,QY)` and `PI = nearestNeighbor(DT,QX,QY,QZ)` allow the query points to be specified in column vector format when working in 2-D and 3-D.

`[PI,D] = nearestNeighbor(DT,QX,...)` returns the index of the nearest point in `DT.X` for each query point location in `QX`. The corresponding Euclidean distances between the query points and their nearest neighbors are returned in `D`.

---

**Note** Note: `nearestNeighbor` is not supported for 2-D triangulations that have constrained edges.

---

## Input Arguments

DT	Delaunay triangulation.
QX	The matrix <code>QX</code> is of size <code>mpts-by-ndim</code> , <code>mpts</code> being the number of query points and <code>ndim</code> the dimension of the space where the points reside.

## Output Arguments

PI            PI is a column vector of point indices that index into the points DT.X. The length of PI is equal to the number of query points mpts

D            D is a column vector of length mpts.

## Examples

Create a Delaunay triangulation:

```
x = rand(10,1);
y = rand(10,1);
dt = DelaunayTri(x,y);
```

Create query points:

```
qrypts = [0.25 0.25; 0.5 0.5];
```

Find the nearest neighbors to the query points:

```
pid = nearestNeighbor(dt, qrypts)
```

## See Also

[pointLocation](#) | [delaunayTriangulation](#) | [triangulation](#)

## ne (MException)

---

<b>Purpose</b>	Compare scalar MException objects for inequality
<b>Syntax</b>	<code>eObj1 ~= eObj2</code>
<b>Description</b>	<code>eObj1 ~= eObj2</code> tests MException objects <code>eObj1</code> and <code>eObj2</code> for inequality, returning logical 1 (true) if the two objects are not identical, otherwise returning logical 0 (false).
<b>See Also</b>	<code>addCause(MException)   disp(MException)   eq(MException)   isequal(MException)   last(MException)   throwAsCaller(MException)   rethrow(MException)   throw(MException)   getReport(MException)   MException   assert   error   try, catch</code>



**Purpose** (Will be removed) Simplex neighbor information

---

**Note** `neighbors(TriRep)` will be removed in a future release. Use `neighbors(triangulation)` instead.

---

`TriRep` will be removed in a future release. Use `triangulation` instead.

---

**Syntax** `SN = neighbors(TR, SI)`

**Description** `SN = neighbors(TR, SI)` returns the simplex neighbor information for the specified simplices `SI`.

**Input Arguments**

<code>TR</code>	Triangulation representation.
<code>SI</code>	<code>SI</code> is a column vector of simplex indices that index into the triangulation matrix <code>TR.Triangulation</code> . If <code>SI</code> is not specified the neighbor information for the entire triangulation is returned, where the neighbors associated with simplex <code>i</code> are defined by the <code>i</code> 'th row of <code>SN</code> .

**Output Arguments**

<code>SN</code>	<code>SN</code> is an <code>m</code> -by- <code>n</code> matrix, where <code>m = length(SI)</code> , the number of specified simplices, and <code>n</code> is the number of neighbors per simplex. Each row <code>SN(i, :)</code> represents the neighbors of the simplex <code>SI(i)</code> .  By convention, the simplex opposite vertex <code>(j)</code> of simplex <code>SI(i)</code> is <code>SN(i, j)</code> . If a simplex has one or more boundary facets, the nonexistent neighbors are represented by <code>NaN</code> .
-----------------	------------------------------------------------------------------------------------------------------------------------------------------------------------------------------------------------------------------------------------------------------------------------------------------------------------------------------------------------------------------------------------------------------------------------------------------------------------------------------------------------------------------------------------------

# TriRep.neighbors

---

## Definitions

A *simplex* is a triangle/tetrahedron or higher-dimensional equivalent. A *facet* is an edge of a triangle or a face of a tetrahedron.

## Examples

### Example 1

Load a 3-D triangulation and use `TriRep` to compute the neighbors of all tetrahedra.

```
load tetmesh
trep = TriRep(tet, X)
nbrs = neighbors(trep)
```

### Example 2

Query a 2-D triangulation created using `DelaunayTri`.

```
x = rand(10,1)
y = rand(10,1)
dt = DelaunayTri(x,y)
```

Find the neighbors of the first triangle:

```
n1 = neighbors(dt, 1)
```

## See Also

[delaunayTriangulation](#) | [triangulation](#)

**Purpose**

Summary of functions in MATLAB .NET interface

**Description**

Use the following functions to bring assemblies from the Microsoft .NET Framework into the MATLAB environment. The functions are implemented as a package called NET. To use these functions, prefix the function name with package name NET.

BeginInvoke	Initiate asynchronous .NET delegate call
cell	Create cell array
Combine	Convenience function for static .NET System.Delegate Combine method
enableNETfromNetworkDrive	Enable access to .NET commands from network drive
EndInvoke	Retrieve result of asynchronous call initiated by .NET System.Delegate BeginInvoke method
NET.addAssembly	Make .NET assembly visible to MATLAB
NET.Assembly	Members of .NET assembly
NET.convertArray	Convert numeric MATLAB array to .NET array
NET.createArray	Array for nonprimitive .NET types
NET.createGeneric	Create instance of specialized .NET generic type
NET.disableAutoRelease	Lock .NET object representing a RunTime Callable Wrapper (COM Wrapper) so that MATLAB does not release COM object

NET.enableAutoRelease	Unlock .NET object representing a RunTime Callable Wrapper (COM Wrapper) so that MATLAB releases COM object
NET.GenericClass	Represent parameterized generic type definitions
NET.invokeGenericMethod	Invoke generic method of object
NET.isNETSupported	Check for supported
NET.NetException	Capture error information for .NET exception
NET.setStaticProperty	Static property or field name
Remove	Convenience function for static .NET System.Delegate Remove method
RemoveAll	Convenience function for static .NET System.Delegate RemoveAll method

## How To

- “Call .NET Libraries”

<b>Purpose</b>	Make .NET assembly visible to MATLAB
<b>Syntax</b>	<pre>asmInfo = NET.addAssembly(globalName) asmInfo = NET.addAssembly(privateName)</pre>
<b>Description</b>	<p><code>asmInfo = NET.addAssembly(globalName)</code> loads a global .NET assembly into MATLAB.</p> <p><code>asmInfo = NET.addAssembly(privateName)</code> loads a private .NET assembly.</p>
<b>Tips</b>	<ul style="list-style-type: none"><li>• MATLAB dynamically loads the <code>mscorlib.dll</code> and <code>system.dll</code> assemblies from the .NET Framework class library the first time you type "NET." or "System.". You do not need to call <code>NET.addAssembly</code> to access classes in these assemblies.</li><li>• Refer to your .NET product documentation for the name of the assembly and its deployment type (global or private).</li></ul>
<b>Limitations</b>	<ul style="list-style-type: none"><li>• <code>NET.addAssembly</code> does not support assemblies generated by the MATLAB Builder NE product.</li></ul>
<b>Input Arguments</b>	<p><b>globalName</b></p> <p>One of the following:</p> <ul style="list-style-type: none"><li>• String representing the name of a global assembly.</li><li>• Instance of <code>System.Reflection.AssemblyName</code> class.</li></ul> <p><b>privateName</b></p> <p>String representing the full path of a private assembly.</p>
<b>Output Arguments</b>	<p><b>asmInfo</b></p> <p><code>NET.Assembly</code> object containing names of the members of the assembly.</p>

# NET.addAssembly

---

## Examples

Display today's date using `System.DateTime` in the `mscorlib` assembly.

```
System.DateTime.Now.ToLongDateString
```

---

Call the `System.Windows.Forms.MessageBox.Show` method in the global assembly `System.Windows.Forms`.

```
asm = NET.addAssembly('System.Windows.Forms');
import System.Windows.Forms.*;
MessageBox.Show('Simple Message Box')
```

---

Display classes in the private assembly `NetSample.dll`.

```
asm = NET.addAssembly('c:\work\NetSample.dll');
asm.Classes
```

## See Also

[NET.Assembly](#)

## How To

- “An Assembly is a Library of .NET Classes”

## Related Links

- [MSDN AssemblyName Class](#)

<b>Purpose</b>	Members of .NET assembly
<b>Description</b>	NET.Assembly object returns names of the members of an assembly.
<b>Construction</b>	The NET.addAssembly function creates an instance of this class.
<b>Properties</b>	<b>AssemblyHandle</b> Instance of System.Reflection.Assembly class of the added assembly.
	<b>Classes</b> nClassx1 cell array of class names of the assembly, where nClass is the number of classes
	<b>Enums</b> nEnumx1 cell array of enums of the assembly, where nEnum is the number of enums
	<b>Structures</b> nStructx1 cell array of structures of the assembly, where nStruct is the number of structures
	<b>GenericTypes</b> nGenTypex1 cell array of generic types of the assembly, where nGenType is the number of generic types
	<b>Interfaces</b> nInterfacex1 cell array of interface names of the assembly, where nInterface is the number of interfaces
	<b>Delegates</b> nDelegatex1 cell array of delegates of the assembly, where nDelegate is the number of delegates
<b>See Also</b>	NET.addAssembly

# NET.Assembly

---

## How To

- “What Classes Are in a .NET Assembly?”



**Purpose** Convert numeric MATLAB array to .NET array

---

**Note** MATLAB automatically converts arrays to .NET types. For information, see “Using Arrays with .NET Applications”.

---

**Syntax** `arrObj = NET.convertArray(V, 'arrType', [m,n])`

**Description** `arrObj = NET.convertArray(V, 'arrType', [m,n])` converts a MATLAB array `V` to a .NET array. Optional value `arrType` is a string representing a namespace-qualified .NET array type. Use optional values `m,n` to convert a MATLAB vector to a two-dimensional .NET array (either 1-by-`n` or `m`-by-1). If `V` is a MATLAB vector and you do not specify the number of dimensions and their sizes, the output `arrObj` is a one-dimensional .NET array.

If you do not specify `arrType`, MATLAB converts the type according to the MATLAB Primitive Type Conversion Table. See “Pass Primitive .NET Types”.

**Examples** Create a list `aList` of random `System.Int32` integers using the `System.Collections.Generic.List` class, and then sort the results:

```
%Create array R of random integers
nInt = 5;
R = randi(100,1,nInt);
%Create .NET array A
A = NET.convertArray(R, 'System.Int32');
%Put A into aList, a generic collections list
aList = NET.createGeneric(...
 'System.Collections.Generic.List',...
 {'System.Int32'},A.Length);
aList.AddRange(A);
%Sort the values in aList
aList.Sort;
```

# NET.convertArray

---

## See Also

[NET.createArray](#)

## Purpose

Array for nonprimitive .NET types

## Syntax

```
array = NET.createArray(typeName,[m,n,p,...])
array = NET.createArray(typeName,m,n,p,...)
```

## Description

`array = NET.createArray(typeName,[m,n,p,...])` creates an m-by-n-by-p-by-... array of type `typeName`, which is either a fully qualified .NET array type name (namespace and array type name) or an instance of the `NET.GenericClass` class, in case of arrays of generic type. `m,n,p,...` are the number of elements in each dimension of the array.

`array = NET.createArray(typeName,m,n,p,...)` alternative syntax for creating an array.

You cannot specify the lower bound of an array.

## Examples

### Create .NET Array of Generic Type

This example creates a .NET array of `List<Int32>` generic type.

```
genType = NET.GenericClass('System.Collections.Generic.List',...
 'System.Int32');
arr = NET.createArray(genType, 5)
```

```
arr =
```

```
List<System*Int32>[] with properties:
```

```
 Length: 5
 LongLength: 5
 Rank: 1
 SyncRoot: [1x1 System.Collections.Generic.List<System*Int32>
 ReadOnly: 0
 IsFixedSize: 1
 IsSynchronized: 0
```

# NET.createArray

---

## Create and Initialize Jagged Array

This example creates a jagged .NET array of 3 elements.

```
jaggedArray = NET.createArray('System.Double[]', 3)
```

```
jaggedArray =
```

```
 Double[][] with properties
```

```
 Length: 3
 LongLength: 3
 Rank: 1
 SyncRoot: [1x1 System.Double[][]]
 IsReadOnly: 0
 IsFixedSize: 1
 IsSynchronized: 0
```

Assign values:

```
jaggedArray(1) = [1, 3, 5, 7, 9];
jaggedArray(2) = [0, 2, 4, 6];
jaggedArray(3) = [11, 22];
```

Access first value of 3rd array:

```
jaggedArray(3,1)
```

```
ans =
 11
```

## Create Jagged Array of Generic Type

This example creates a jagged array of List<Double> generic type.

```
genCls = NET.GenericClass('System.Collections.Generic.List[]',...
 'System.Double');
```

Create the array, genArr.

```
genArr = NET.createArray(genCls,3)
```

```
genArr =
```

```
List<System*Double>[[]] with properties:
```

```
 Length: 3
 LongLength: 3
 Rank: 1
 SyncRoot: [1x1 System.Collections.Generic.List`1[[]]]
 IsReadOnly: 0
 IsFixedSize: 1
 IsSynchronized: 0
```

## Create Nested Jagged Array

This command creates a jagged array of type `System.Double[[][]]`.

```
netArr = NET.createArray('System.Double[[]]', 3)
```

```
netArr =
```

```
Double[[][]] with properties:
```

```
 Length: 3
 LongLength: 3
 Rank: 1
 SyncRoot: [1x1 System.Double[[]]]
 IsReadOnly: 0
 IsFixedSize: 1
 IsSynchronized: 0
```

## See Also

[NET.convertArray](#) | [NET.createGeneric](#)

# NET.createGeneric

---

<b>Purpose</b>	Create instance of specialized .NET generic type
<b>Syntax</b>	<code>genObj = createGeneric(className,paramTypes,varargin ctorArgs)</code>
<b>Description</b>	<code>genObj = createGeneric(className,paramTypes,varargin ctorArgs)</code> creates an instance <code>genObj</code> of generic type <code>className</code> .

<b>Input Arguments</b>	<code>className</code>	Fully qualified string with the generic type name.
	<code>paramTypes</code>	Allowed cell types are: strings with fully qualified parameter type names and instances of the <code>NET.GenericClass</code> class when parameterization with another parameterized type is needed.
	<code>ctorArgs</code>	Optional, variable length (0 to N) list of constructor arguments matching the arguments of the .NET generic class constructor intended to be invoked.

<b>Output Arguments</b>	<code>genObj</code>	Handle to the specialized generic class instance.
-------------------------	---------------------	---------------------------------------------------

## Examples **Create a List of System.Double Objects**

Create a strongly typed list `dblLst` of objects of type `System.Double`:

```
t = NET.createGeneric('System.Collections.Generic.List',...
 {'System.Double'},10);
```

## **Create a List with Key/Value Pairs**

Create the `kvpType` generic association where Key is of `System.Int32` type and Value is a `System.String`:

```
pe = NET.GenericClass('System.Collections.Generic.KeyValuePair',...
 'System.Int32', 'System.String');
```

Create the list `kvpList` with initial storage capacity for 10 key-value pairs:

```
st = NET.createGeneric('System.Collections.Generic.List',...
 {kvpType}, 10);
```

## **Add an Item to the List**

Create a `KeyValuePair` item.

```
kvpItem = NET.createGeneric('System.Collections.Generic.KeyValuePair',...
 {'System.Int32', 'System.String'}, 42, 'myString');
```

Add this item to the list `kvpList`.

```
kvpList.Add(kvpItem);
```

## **See Also**

`NET.GenericClass`

# NET.disableAutoRelease

---

**Purpose** Lock .NET object representing a RunTime Callable Wrapper (COM Wrapper) so that MATLAB does not release COM object

**Syntax** A = NET.disableAutoRelease(obj)

**Description** A = NET.disableAutoRelease(obj) locks a .NET object representing a RunTime Callable Wrapper (COM Wrapper) so that MATLAB does not release the COM object. obj is a .NET object representing a COM Wrapper.

Before passing a .NET object representing a COM Wrapper to another process, lock the object using this function so that MATLAB does not release it. After using the object, call NET.enableAutoRelease to release the COM object.

**Examples** The following user-defined function, GetComApp.m, has access to a COM object defined in the **pseudo-class** ComNamespace.ComClass. One of its methods is readData, with the signature:

```
System.StringRetVal readData(ComNamespace.ComClass this, System.String strIn)
```

The input argument is defined in the **pseudo-class** NetDocTest.MyClass, which has a property named MyApp.

```
function GetComApp(obj)
comObj = ComNamespace.ComClass;
obj.MyApp = comObj;
% To pass a COM object to another process, lock the object
NET.disableAutoRelease(comObj);
end
```

The example in NET.enableAutoRelease shows how to call the GetComApp function.

**See Also** NET.enableAutoRelease

**How To** • “How MATLAB Handles System.\_\_ComObject”



**Purpose** Unlock .NET object representing a RunTime Callable Wrapper (COM Wrapper) so that MATLAB releases COM object

**Syntax** A = NET.enableAutoRelease(obj)

**Description** A = NET.enableAutoRelease(obj) releases the COM wrapper when the object goes out of scope, where obj is a .NET object representing a COM Wrapper.

Call this function only if the object was locked using NET.disableAutoRelease.

**Examples** The following **pseudo-code** shows how to call a function (GetComApp.m, described in NET.disableAutoRelease) which returns a COM object. The object, mainObj of type NetDocTest.MyClass, has a property, MyApp. Call GetComApp to get a COM object, and use its readData method.

```
mainObj = NetDocTest.MyClass;
GetComApp(mainObj);
app = mainObj.MyApp;
app.readData('hello');
% Unlock the COM object
NET.enableAutoRelease(mainObj.MyApp);
```

**See Also** NET.disableAutoRelease

**How To** • “How MATLAB Handles System.\_\_ComObject”

# NET.GenericClass

---

**Purpose** Represent parameterized generic type definitions

**Description** Instances of this class are used by the `NET.createGeneric` function when creation of generic specialization requires parameterization with another parameterized type.

**Construction** `genType = NET.GenericClass (className, paramTypes)`

## Input Arguments

### className

Fully qualified string containing the generic type name.

### paramTypes

Optional, variable length (1 to N) list of types for the generic class parameterization. Allowed argument types are:

- Fully qualified string containing the generic type name.
- Instance of the `NET.GenericClass` class when deeper nested parameterization with another parameterized type is needed.

## Examples

Create an instance of `System.Collections.Generic.List` of `System.Collections.Generic.KeyValuePair` generic associations where `Key` is of `System.Int32` type and `Value` is a `System.String` class with initial storage capacity for 10 key-value pairs.

```
kvpType = NET.GenericClass(...
 'System.Collections.Generic.KeyValuePair',...
 'System.Int32', 'System.String');
kvpList = NET.createGeneric('System.Collections.Generic.List',...
 { kvpType }, 10);
```

**See Also** `NET.createGeneric` | `NET.createArray` | `NET.invokeGenericMethod`

**How To**

- “.NET Generic Classes”

<b>Purpose</b>	Invoke generic method of object								
<b>Syntax</b>	<pre>[varargout] = NET.invokeGenericMethod(obj, 'genericMethodName',     paramTypes, args, ...)</pre>								
<b>Description</b>	<pre>[varargout] = NET.invokeGenericMethod(obj, 'genericMethodName', paramTypes, args, ...) calls instance or static generic method <i>genericMethodName</i>.</pre>								
<b>Input Arguments</b>	<table><tr><td>obj</td><td>Allowed argument types are:<ul style="list-style-type: none"><li>• Instances of class containing the generic method</li><li>• Strings with fully qualified class name, if calling static generic methods</li><li>• Instances of NET.GenericClass definitions, if calling static generic methods of a generic class</li></ul></td></tr><tr><td><i>genericMethodName</i></td><td>Generic method name to invoke</td></tr><tr><td>paramTypes</td><td>Cell vector (1 to N) with the types for generic method parameterization, where allowed cell types are:<ul style="list-style-type: none"><li>• Strings with fully qualified parameter type name.</li><li>• Instances of NET.GenericClass definitions, if using nested parameterization with another parameterized type</li></ul></td></tr><tr><td>args</td><td>Optional, variable length (0 to N) list of method arguments</td></tr></table>	obj	Allowed argument types are: <ul style="list-style-type: none"><li>• Instances of class containing the generic method</li><li>• Strings with fully qualified class name, if calling static generic methods</li><li>• Instances of NET.GenericClass definitions, if calling static generic methods of a generic class</li></ul>	<i>genericMethodName</i>	Generic method name to invoke	paramTypes	Cell vector (1 to N) with the types for generic method parameterization, where allowed cell types are: <ul style="list-style-type: none"><li>• Strings with fully qualified parameter type name.</li><li>• Instances of NET.GenericClass definitions, if using nested parameterization with another parameterized type</li></ul>	args	Optional, variable length (0 to N) list of method arguments
obj	Allowed argument types are: <ul style="list-style-type: none"><li>• Instances of class containing the generic method</li><li>• Strings with fully qualified class name, if calling static generic methods</li><li>• Instances of NET.GenericClass definitions, if calling static generic methods of a generic class</li></ul>								
<i>genericMethodName</i>	Generic method name to invoke								
paramTypes	Cell vector (1 to N) with the types for generic method parameterization, where allowed cell types are: <ul style="list-style-type: none"><li>• Strings with fully qualified parameter type name.</li><li>• Instances of NET.GenericClass definitions, if using nested parameterization with another parameterized type</li></ul>								
args	Optional, variable length (0 to N) list of method arguments								

# NET.invokeGenericMethod

---

## Output Arguments

varargout      Variable-length output argument list, varargout, from method *genericMethodName*

## Examples

Use the following syntax to call a generic method that takes two parameterized types and returns a parameterized type:

```
a = NET.invokeGenericMethod(obj, ...
 'myGenericSwapMethod', ...
 {'System.Double', 'System.Double'}, ...
 5, 6);
```

---

To display generic methods in MATLAB, see the example “Display .NET Generic Methods Using Reflection”.

## See Also

NET.GenericClass | NET.createGeneric | varargout

## How To

- “Call .NET Generic Methods”

**Purpose**

Check for supported Microsoft .NET Framework

**Syntax**

```
tf = NET.isNETSupported
```

**Description**

`tf = NET.isNETSupported` returns logical 1 (true) if a supported version of the Microsoft .NET Framework is found. Otherwise, it returns logical 0 (false) and you cannot use the .NET Framework in MATLAB.

# NET.NetException

---

<b>Purpose</b>	Capture error information for .NET exception
<b>Description</b>	Process information from a NET.NetException object to handle .NET errors. This class is derived from MException.
<b>Construction</b>	<code>e = NET.NetException(msgID, errMsg, netObj)</code> constructs instance <code>e</code> of NET.NetException class.
<b>Input Arguments</b>	<b>msgID</b> message identifier <b>errMsg</b> error message string <b>netObj</b> System.Exception object that caused the exception
<b>Properties</b>	<b>ExceptionObject</b> System.Exception class causing the error.
<b>Methods</b>	<b>Inherited Methods</b> See the methods of the base class MException.
<b>Examples</b>	Display error information after trying to load an unknown assembly: <pre>try   NET.addAssembly('C:\Work\invalidfile.dll') catch e   e.message;   if(isa(e, 'NET.NetException'))     eObj = e.ExceptionObject   end end  ans =</pre>

```
Message: Could not load file or assembly
'file:///C:\Work\invalidfile.dll' or
one of its dependencies. The system cannot
find the file specified.
```

```
Source: mscorlib
```

```
HelpLink:
```

```
eObj =
```

```
FileNotFoundException with properties:
```

```
 Message: [1x1 System.String]
 FileName: [1x1 System.String]
 FusionLog: [1x1 System.String]
 Data: [1x1 System.Collections.ListDictionaryInternal]
 InnerException: []
 TargetSite: [1x1 System.Reflection.RuntimeMethodInfo]
 StackTrace: [1x1 System.String]
 HelpLink: []
 Source: [1x1 System.String]
```

## See Also

MException

## How To

- Class Attributes
- Property Attributes

# NET.setStaticProperty

---

**Purpose** Static property or field name

**Syntax** `NET.setStaticProperty('propName', value)`

**Description** `NET.setStaticProperty('propName', value)` sets the static property or field name specified in the string `propName` to the given value.

**Examples** To set the `myStaticProperty` in the given class and namespace, use the syntax:

```
NET.setStaticProperty('MyTestObject.MyClass.myStaticProperty', 5);
```



<b>Purpose</b>	Create variable in NetCDF file
<b>Syntax</b>	<code>nccreate(filename,varname)</code> <code>nccreate(filename,varname,Name,Value)</code>
<b>Description</b>	<p><code>nccreate(filename,varname)</code> creates a scalar double variable named <code>varname</code> in the NetCDF file <code>filename</code>. If <code>filename</code> does not exist, <code>nccreate</code> creates the file using the <code>netcdf4_classic</code> format. To create a nonscalar variable, use the <code>Dimensions</code> argument.</p> <p><code>nccreate(filename,varname,Name,Value)</code> creates a variable named <code>varname</code> with additional options specified by one or more <code>Name,Value</code> pair arguments.</p>
<b>Input Arguments</b>	<p><b>filename</b></p> <p>Text string specifying a NetCDF file, or the name you want to assign to a new NetCDF file.</p> <p><b>varname</b></p> <p>Text string specifying the name you want to assign to a variable in a NetCDF file.</p> <p><b>Name-Value Pair Arguments</b></p> <p>Specify optional comma-separated pairs of <code>Name,Value</code> arguments. <code>Name</code> is the argument name and <code>Value</code> is the corresponding value. <code>Name</code> must appear inside single quotes ( ' '). You can specify several name and value pair arguments in any order as <code>Name1,Value1,...,NameN,ValueN</code>.</p> <p><b>'Dimensions'</b></p> <p>Cell array specifying dimensions for the variable in the NetCDF file. The cell array lists the dimension name as a string followed by its numerical length: <code>{dname1,dlength1,dname2,dlength2,...}</code>. If a dimension exists, specifying its length is optional. Use <code>Inf</code> to specify an unlimited dimension.</p>

All formats other than `netcdf4` format files can have only one unlimited dimension per file and it has to be the last in the list specified. A `netcdf4` format file can have any number of unlimited dimensions in any order.

A single-dimension variable is always treated as a column vector.

## 'Datatype'

Text string specifying a MATLAB data type. When `nccreate` creates the variable in the NetCDF file, it uses a corresponding NetCDF datatype. The following table describes how MATLAB datatypes map to NetCDF datatypes.

<b>MATLAB Data Type</b>	<b>Corresponding NetCDF Variable Type</b>
<code>double</code>	<code>NC_DOUBLE</code>
<code>single</code>	<code>NC_FLOAT</code>
<code>int64</code>	<code>NC_INT64*</code>
<code>uint64</code>	<code>NC_UINT64*</code>
<code>int32</code>	<code>NC_INT</code>
<code>uint32</code>	<code>NC_UINT*</code>
<code>int16</code>	<code>NC_SHORT</code>
<code>uint16</code>	<code>NC_USHORT*</code>
<code>int8</code>	<code>NC_BYTE</code>
<code>uint8</code>	<code>NC_UBYTE*</code>
<code>char</code>	<code>NC_CHAR</code>

\* These data types are only available when the file is a `netcdf4` format file.

## 'Format'

Text string specifying the type of NetCDF file you want to create.

Format String	Description
classic	NetCDF 3
64bit	NetCDF 3, with 64-bit offsets
netcdf4_classic	NetCDF 4 classic model
netcdf4	NetCDF 4 model (Use this to enable group hierarchy)

If varname specifies a group (e.g., '/grid3/temperature'), nccreate sets the value of format to 'netcdf4'.

**Default:** netcdf4\_classic

#### 'FillValue'

A scalar specifying the value to use for missing values. To disable fill values, set FillValue to the text string 'disable'. (Available for netcdf4 or netcdf4\_classic formats only.)

**Default:** Value specified by the NetCDF library

#### 'ChunkSize'

Vector specifying the size of the chunk along each dimension, [num\_rows,num\_cols,..., num\_ndims]. (Available for netcdf4 or netcdf4\_classic formats only.)

**Default:** Set by the NetCDF library

#### 'DeflateLevel'

Numeric value between 0 (least) and 9 (most) specifying the compression setting for the deflate filter, or the text string disable. (Available for netcdf4 or netcdf4\_classic formats only.)

**Default:** Disabled

## **'Shuffle'**

Boolean flag to turn on the shuffle filter. (Available for netcdf4 or netcdf4\_classic formats only.)

**Default:** False

## **Examples**

Create a new 2-D variable in a classic format file. Write data to this variable

```
nccreate('myncclassic.nc', 'peaks', ...
 'Dimensions', {'r' 200 'c' 200}, ...
 'Format', 'classic');
ncwrite('myncclassic.nc', 'peaks', peaks(200));
ncdisp('myncclassic.nc');
```

## **See Also**

`ncdisp` | `ncwrite` | `ncinfo` | `ncwritescema` | `netcdf`

## **Tutorials**

- “Exporting to NetCDF Files”

**Purpose** Display contents of NetCDF data source in Command Window

**Syntax**  
`ncdisp(source)`  
`ncdisp(source,location)`  
`ncdisp(source,location,dispFormat)`

**Description** `ncdisp(source)` displays all the groups, dimensions, variable definitions, and all attributes in the NetCDF data source, `source`, as text in the Command Window.

`ncdisp(source,location)` displays information about the variable or group specified by `location`.

`ncdisp(source,location,dispFormat)` displays the contents of the NetCDF data source, in the display format specified by `dispFormat`.

## Input Arguments

### **source - Name of NetCDF file**

string

Name of a NetCDF file, specified as a string. `source` also can be the URL of an OPeNDAP NetCDF data source that resolves to a NetCDF file or a variable in a NetCDF file.

**Example:** `'myNetCDFfile.nc'`

### **Data Types**

char

### **location - Location of variable or group**

'/' (default) | string

Location of a variable or group in the NetCDF file, specified as a string. Set `location` to '/' (forward slash) to display the entire contents of the file.

### **Data Types**

char

## dispFormat - Display format

'full' (default) | 'min'

Display format, specified as one of the following strings.

'full'	Display group hierarchy with dimensions, attributes, and variable definitions.
'min'	Display group hierarchy and variable definitions.

## Data Types

char

## Examples

### Display Contents of NetCDF File

Display the contents of the example NetCDF file, `example.nc`.

```
ncdisp('example.nc')
```

Source:

```
matlabroot\toolbox\matlab\demos\example.nc
```

Format:

```
netcdf4
```

Global Attributes:

```
creation_date = '29-Mar-2010'
```

Dimensions:

```
x = 50
```

```
y = 50
```

```
z = 5
```

Variables:

```
avagadros_number
```

```
Size: 1x1
```

```
Dimensions:
```

```
Datatype: double
```

```
Attributes:
```

```
description = 'this variable has no dimensions'
```

```
temperature
```

```
Size: 50x1
```

```
Dimensions: x
```

```

 Datatype: int16
 Attributes:
 scale_factor = 1.8
 add_offset = 32
 units = 'degrees_fahrenheit'
peaks
 Size: 50x50
 Dimensions: x,y
 Datatype: int16
 Attributes:
 description = 'z = peaks(50);'
Groups:
 /grid1/
 Attributes:
 description = 'This is a group attribute.'
 Dimensions:
 x = 360
 y = 180
 time = 0 (UNLIMITED)
 Variables:
 temp
 Size: []
 Dimensions: x,y,time
 Datatype: int16

 /grid2/
 Attributes:
 description = 'This is another group attribute.'
 Dimensions:
 x = 360
 y = 180
 time = 0 (UNLIMITED)
 Variables:
 temp
 Size: []
 Dimensions: x,y,time
 Datatype: int16
```

MATLAB displays all the groups, dimensions, and variable definitions in `example.nc`.

## Display Contents of NetCDF Variable

Display the contents of the variable `peaks` in the file, `example.nc`.

```
ncdisp('example.nc','peaks')
```

Source:

```
matlabroot\toolbox\matlab\demos\example.nc
```

Format:

```
netcdf4
```

Dimensions:

```
x = 50
```

```
y = 50
```

Variables:

```
peaks
```

```
Size: 50x50
```

```
Dimensions: x,y
```

```
Datatype: int16
```

```
Attributes:
```

```
description = 'z = peaks(50);'
```

## Display Contents of NetCDF File and Hide Attributes

Display only the group hierarchy and variable definitions of the example file, `example.nc`.

```
ncdisp('example.nc','/','min')
```

Source:

```
matlabroot\toolbox\matlab\demos\example.nc
```

Format:

```
netcdf4
```

Variables:

```
avagadros_number
```

```
Size: 1x1
```

```
Dimensions:
```

```
Datatype: double
```



```
temperature
 Size: 50x1
 Dimensions: x
 Datatype: int16
peaks
 Size: 50x50
 Dimensions: x,y
 Datatype: int16
Groups:
 /grid1/
 Variables:
 temp
 Size: []
 Dimensions: x,y,time
 Datatype: int16
 /grid2/
 Variables:
 temp
 Size: []
 Dimensions: x,y,time
 Datatype: int16
```

**Tips**

- If source is an OPeNDAP URL with string constraints, use the syntax, `ncdisp(source)` with no other input arguments.

**See Also**

`ncwrite` | `ncinfo` | `ncread` | `netcdf` | `ncreadatt`

**Concepts**

- “Importing NetCDF Files and OPeNDAP Data”

# ncinfo

---

**Purpose** Return information about NetCDF data source

**Syntax**

```
finfo = ncinfo(source)
vinfo = ncinfo(source,varname)
ginfo = ncinfo(source,groupname)
```

**Description**

`finfo = ncinfo(source)` returns information in the structure `finfo` about the entire NetCDF data source specified by `source`, where `source` can be the name of a NetCDF file or the URL of an OPeNDAP NetCDF data source.

`vinfo = ncinfo(source,varname)` returns information in the structure `vinfo` about the variable `varname` in `source`.

`ginfo = ncinfo(source,groupname)` returns information in the structure `ginfo` about the group `groupname` in `source` (only NetCDF4 data sources).

---

**Note** Use `ncdisp` for visual inspection of a NetCDF source.

---

## Input Arguments

### **source**

Text string specifying the name of a NetCDF file or the URL of an OPeNDAP NetCDF data source.

### **varname**

Text string specifying the name of a variable in a NetCDF file or OPeNDAP data source.

### **groupname**

Text string specifying the name of a group in a NetCDF file or OPeNDAP data source.

## Output Arguments

### finfo

A structure with the following fields.

Field	Description	
Filename	NetCDF file name or OPeNDAP URL	
Name	' / ', indicating the full file	
Dimensions	An array of structures with these fields:	
	Name	Dimension name
	Length	Current length of dimension
	Unlimited	Boolean flag, true for unlimited dimensions
Variables	An array of structures with these fields:	
	Name	Variable name
	Dimensions	Associated dimensions
	Size	Current variable size
	Datatype	MATLAB datatype
	Attributes	Associated variable attributes
	ChunkSize	Chunk size, if defined. [ ] otherwise
	FillValue	Fill value of the variable.
	DeflateLevel	Deflate filter level, if enabled.
	Shuffle	Shuffle filter enabled flag
Attributes	An array of global attributes with these fields:	
	Name	Attribute name
	Value	Attribute value

Field	Description	
Groups	An array of groups present in the file, for netcdf4 files; An empty array ([]) for all other NetCDF file formats.	
Format	The format of the NetCDF file	

## **vinfo**

A structure containing only the variable fields from `finfo`.

Field	Description
Filename	NetCDF file name
Name	Name of the variable
Dimensions	Dimensions of the variable
Size	Size of the current variable
Datatype	MATLAB datatype
Attributes	Attributes associated with the variable
ChunkSize	Chunk size, if defined. [] otherwise.
FillValue	Fill value used in the variable.
DeflateLevel	Deflate filter level, if enabled.
Shuffle	Shuffle filter enabled flag
Format	The format of the NetCDF file

## **ginfo**

A structure containing only the group fields from `finfo`.

Field	Description
Filename	NetCDF file name
Name	Name of the group

Field	Description
Dimensions	Only dimensions defined in the specified group
Variables	Only variables defined in the specified group
Attributes	Attributes associated with the variable
Groups	Names of groups, if defined. [] otherwise.
Format	The format of the NetCDF file

## Examples

Search for dimensions with names that start with the character x in the file.

```
finfo = ncinfo('example.nc');
disp(finfo);
dimNames = {finfo.Dimensions.Name};
dimMatch = strncmpi(dimNames,'x',1);
disp(finfo.Dimensions(dimMatch));
```

Obtain the size of a variable and check if it has any unlimited dimensions.

```
vinfos = ncinfo('example.nc','peaks');
varSize =vinfos.Size;
disp(vinfos);
hasUnLimDim = any([vinfos.Dimensions.Unlimited]);
```

Find all unlimited dimensions defined in a group.

```
ginfo = ncinfo('example.nc','/grid2/');
unlimDims = [ginfo.Dimensions.Unlimited];
disp(ginfo.Dimensions(unlimDims));
```

# ncinfo

---

## **See Also**

`ncdisp` | `ncwrite` | `ncread` | `ncwritschema` | `netcdf`

## **Tutorials**

- “Importing NetCDF Files and OPeNDAP Data”

**Purpose**

Read data from variable in NetCDF data source

**Syntax**

```
vardata = ncread(source,varname)
vardata = ncread(source,varname,start,count,stride)
```

**Description**

`vardata = ncread(source,varname)` reads data from the variable `varname` in `source`, which can be either the name of a NetCDF file or an OPeNDAP NetCDF data source.

`vardata = ncread(source,varname,start,count,stride)` reads data from the variable `varname` in `source` beginning at the location given by `start`. `count` specifies the number of elements to read along the corresponding dimension. The optional argument `stride` specifies the inter-element spacing along each dimension.

**Input Arguments****source**

Text string specifying the name of a NetCDF file or the URL of an OPeNDAP NetCDF data source.

**varname**

Text string specifying the name of a variable in the NetCDF file or OPeNDAP NetCDF data source.

**start**

For an  $N$ -dimensional variable, `start` is a vector of length  $N$  of indices specifying the starting location. Indices are 1-based.

**count**

Vector of length  $N$  specifying the number of elements to read along the corresponding dimensions. If a particular element of `count` is `Inf`, `ncread` reads data until the end of the corresponding dimension.

**stride**

Optional argument that specifies the inter-element spacing along each dimension.

**Default:** Vector of 1s (ones)

## Output Arguments

### **vardata**

The data in the variable. `ncread` uses the MATLAB datatype that is the closest type to the corresponding NetCDF datatype, except when at least one of `_FillValue`, `scale_offset`, and `add_offset` variables attribute is present. `ncread` applies the following attribute conventions, in sequence, to `vardata` if the corresponding attribute exists for this variable:

- If the `_FillValue` attribute exists, `ncread` replaces values in `vardata` equal to the value of `_FillValue` with NaNs. If the `_FillValue` attribute does not exist, `ncread` queries the NetCDF library for the variable's fill value.
- If the `scale_factor` attribute exists, `ncread` multiplies `vardata` by the value of the `scale_factor` attribute.
- If the `add_offset` attribute exists, `ncread` adds the value of the `add_offset` attribute to `vardata`.

## Examples

Read and display the data in the `peaks` variable in the example file.

```
ncdisp('example.nc','peaks');
peaksData = ncread('example.nc','peaks');
peaksDesc = ncreadatt('example.nc','peaks','description');
surf(double(peaksData));
title(peaksDesc);
```

---

Subsample the `peaks` data by a factor of 2 (read every other value along each dimension).

```
subsetdata = ncread('example.nc','peaks',...
 [1 1], [Inf Inf], [2 2]);
```



```
surf(double(subsetdata));
```

## See Also

`ncdisp` | `ncinfo` | `netcdf` | `ncwrite` | `ncreadatt`

## Tutorials

- “Importing NetCDF Files and OPeNDAP Data”

# ncreadatt

---

**Purpose** Read attribute value from NetCDF data source

**Syntax** `attvalue = ncreadatt(source,location,attname)`

**Description** `attvalue = ncreadatt(source,location,attname)` reads the attribute `attname` from the group or variable specified by `location` in `source`, where `source` is the name of a NetCDF file or the URL of a NetCDF data source.

## Input Arguments

### **source**

Text string specifying the name of a NetCDF file or the URL of an OPeNDAP NetCDF data source.

### **location**

Text string specifying a group or variable in the NetCDF data source. To read global attributes, set `location` to `'/'` (forward slash).

### **attname**

Text string specifying the name of an attribute that you want to read in the NetCDF data source.

## Output Arguments

### **attvalue**

Data associated with the attribute.

## Examples

Read a global attribute.

```
creation_date = ncreadatt('example.nc','/','creation_date');
disp(creation_date);
```

---

Read an attribute associated with a variable.

```
scale_factor = ncreadatt('example.nc','temperature','scale_factor');
disp(scale_factor);
```

---

Read an attribute associated with a group (netcdf4 format files only).

```
desc_value = ncreadatt('example.nc', '/grid2', 'description');
disp(desc_value);
```

## See Also

[ncdisp](#) | [ncinfo](#) | [ncread](#) | [netcdf](#) | [ncwriteatt](#)

## Tutorials

- “Importing NetCDF Files and OPeNDAP Data”

# ncwrite

---

## Purpose

Write data to NetCDF file

## Syntax

```
ncwrite(filename,varname,vardata)
ncwrite(filename,varname,vardata,start, stride)
```

## Description

`ncwrite(filename,varname,vardata)` writes the numerical or char data in `vardata` to an existing variable `varname` in the NetCDF file `filename`. `ncwrite` writes the data in `vardata` starting at the beginning of the variable and extends unlimited dimensions automatically, if needed.

If the NetCDF file or the variable do not exist, use `nccreate` to create them first.

`ncwrite(filename,varname,vardata,start, stride)` writes `vardata` to an existing variable `varname` in file `filename` beginning at the location given by `start`. `stride` is an optional argument that specifies the inter-element spacing of the data written. Use this syntax to append data to an existing variable or write partial data.

## Tips

- If the variable `varname` already exists, `ncwrite` expects the datatype of `vardata` to match the NetCDF variable data type.
- If the variable `varname` has a `_FillValue`, `scale_factor` or `add_offset` attribute, `ncwrite` expects data in double format and casts `vardata` to the NetCDF data type, after applying the following attribute conventions in sequence:
  - 1 Subtract the value of the `add_offset` attribute from `vardata`.
  - 2 Divide `vardata` by the value of the `scale_factor` attribute.
  - 3 Replace NaNs in `vardata` by the value of the `_FillValue` attribute. If this attribute does not exist, `ncwrite` tries to use the fill value for this variable as reported by the NetCDF library.

## Input Arguments

### **filename**

Text string specifying the name of a NetCDF file. If the file does not exist, use `nccreate` to create it first.

**varname**

Text string specifying the name of a variable in a NetCDF file. If the variable does not exist, use `nccreate` to create it first.

**vardata**

Data to write to the variable in the NetCDF file.

**start**

For an  $N$ -dimensional variable, `start` is a vector of indices of length  $N$  specifying the starting location. Indices are 1-based.

**stride**

(Optional) Vector of length  $N$ , specifying the inter-element spacing.

**Default:** Vector of ones

## Examples

Create a new `netcdf4_classic` file, and write a scalar variable with no dimensions. Add the creation time as a global attribute.

```
nccreate('myfile.nc', 'pi');
ncwrite('myfile.nc', 'pi', 3.1);
ncwriteatt('myfile.nc', '/', 'creation_time', datestr(now));
% overwrite existing data
ncwrite('myfile.nc', 'pi', 3.1416);
ncdisp('myfile.nc');
```

Create a `netcdf4_classic` file with a variable defined on an unlimited dimension. Write data incrementally to the variable.

```
nccreate('mynctest.nc', 'vmark', ...
 'Dimensions', {'time', inf, 'cols', 6}, ...
 'ChunkSize', [3 3], ...
 'DeflateLevel', 2);
ncwrite('mynctest.nc', 'vmark', eye(3), [1 1]);
```

# ncwrite

---

```
varData = ncread('myncfile.nc','vmark');
disp(varData);
ncwrite('myncfile.nc','vmark',fliplr(eye(3)),[1 4]);
varData = ncread('myncfile.nc','vmark');
disp(varData);
```

## See Also

[ncdisp](#) | [ncread](#) | [ncinfo](#) | [netcdf](#) | [ncwriteatt](#) | [nccreate](#)

## Tutorials

- “Exporting to NetCDF Files”

---

<b>Purpose</b>	Write attribute to NetCDF file
<b>Syntax</b>	<code>ncwriteatt(filename,location,attname,attvalue)</code>
<b>Description</b>	<code>ncwriteatt(filename,location,attname,attvalue)</code> creates or modifies the attribute specified by <code>attname</code> in the group or variable specified by <code>location</code> , in the NetCDF file specified by <code>filename</code> . <code>attvalue</code> can be a numeric vector or a string.
<b>Input Arguments</b>	<p><b>filename</b> Text string specifying the name of a NetCDF file</p> <p><b>location</b> Text string specifying a group or variable in the NetCDF file. To write global attributes, set <code>location</code> to <code>'/'</code> (forward slash).</p> <p><b>attname</b> Text string specifying the name of an existing attribute in a NetCDF file or the name of the attribute that you want to create.</p> <p><b>attvalue</b> Numeric vector or a string.</p>
<b>Examples</b>	<p>Create a global attribute.</p> <pre>copyfile(which('example.nc'),'myfile.nc'); fileattrib('myfile.nc','+w'); ncdisp('myfile.nc'); ncwriteatt('myfile.nc','/','creation_date',datestr(now)); ncdisp('myfile.nc');</pre> <hr/> <p>Modify an existing attribute.</p>

# ncwriteatt

---

```
copyfile(which('example.nc'),'myfile.nc');
fileattrib('myfile.nc','+w');
ncdisp('myfile.nc','peaks');
ncwriteatt('myfile.nc','peaks','description','Output of PEAKS');
ncdisp('myfile.nc','peaks');
```

## See Also

[ncdisp](#) | [ncreadatt](#) | [ncwrite](#) | [ncread](#) | [ncreate](#) | [netcdf](#)

## Tutorials

- [“Exporting to NetCDF Files”](#)



## Purpose

Add NetCDF schema definitions to NetCDF file

## Syntax

```
ncwritescema(filename,schema)
```

## Description

`ncwritescema(filename,schema)` creates or adds attributes, dimensions, variable definitions and group structure defined in `schema` to the file `filename`.

Use `ncwritescema` in combination with `ncinfo` to create a new NetCDF file based on the schema of an existing file. You can also use `ncwritescema` to add variable definitions, attributes, dimensions, or group structure to an existing file.

---

**Note** `ncwritescema` does not write variable data. Use `ncwrite` to write data to the created variables. Created unlimited dimensions will have an initial size of 0 until you write data.

---

---

**Note** `ncwritescema` cannot change the format of an existing file. It cannot redefine existing variables and dimensions in `filename`. If your schema contains attributes, dimensions, variable definitions, or a group structure that already exist in the file, `writescema` issues a warning but continues processing.

---

## Input Arguments

### **filename**

Text string specifying the name of a NetCDF file. If `filename` does not exist, `ncwritescema` creates a new file using the `netcdf4_classic` format, unless the `Format` field in `schema` specifies another format.

### **schema**

A structure, or array of structures, representing either a dimension, variable, an entire NetCDF file, or a `netcdf4` group. A group or file schema can contain a dimension or variable schema, or both. You can

# ncwritschema

---

use the output returned by `ncinfo` as a schema structure. The following table lists the fields in the various types of schema structures. Optional fields are marked with asterisk (\*).

Schema Type	Structure Field	Description
Group/File Schema	Name	Text string identifying the group name. Use '/' to indicate the entire file.
	Dimensions*	Dimension schema
	Variables*	Variable schema
	Attributes*	Structure array of group/global attributes with Name and Value fields
	Format*	Text string identifying a NetCDF file format
Dimension schema	Name	Text string identifying the dimension
	Length	Length of the dimension. Can be Inf.
	Unlimited*	Boolean flag indicating if the dimension is unlimited
	Format*	Text string identifying a NetCDF file format
Variable schema	Name	Text string identifying a variable name
	Dimensions	Variable's dimension schema
	Datatype	Text string identifying a MATLAB datatype
	Attributes*	Structure array of variable attributes with Name and Value fields

Schema Type	Structure Field	Description
	ChunkSize*	Numeric value specifying chunk size of the variable
	FillValue*	Character or numeric fill value
	DeflateValue*	Deflate compression level
	Shuffle*	Boolean flag to turn on the Shuffle filter
	Format*	Text string identifying a NetCDF file format

## Examples

Create a classic format file with two dimension definitions.

```
mySchema.Name = '/';
mySchema.Format = 'classic';
mySchema.Dimensions(1).Name = 'time';
mySchema.Dimensions(1).Length = Inf;
mySchema.Dimensions(2).Name = 'rows';
mySchema.Dimensions(2).Length = 10;
ncwritescema('emptyFile.nc', mySchema);
ncdisp('emptyFile.nc');
```

Create a netcdf4\_classic format file to store a single variable from an existing file. First use ncinfo to get the schema of the peaks variable from the file. Then use ncwritescema to create a NetCDF file, defining the peaks variable. Use ncread to get the data associated with the peaks variable and then use ncwrite to write the data to the variable in the new NetCDF file.

```
myVarSchema = ncinfo('example.nc', 'peaks');
ncwritescema('peaksFile.nc', myVarSchema);
peaksData = ncread('example.nc', 'peaks');
ncwrite('peaksFile.nc', 'peaks', peaksData);
ncdisp('peaksFile.nc');
```

# ncwritschema

---

## **See Also**

`ncdisp` | `ncinfo` | `ncwrite` | `ncread` | `netcdf`

## **Tutorials**

- “Exporting to NetCDF Files”

**Purpose** Summary of MATLAB Network Common Data Form (NetCDF) capabilities

**Description** MATLAB provides both high- and low-level access to NetCDF files:

- High-level access functions make it easy to read a data set from a NetCDF file or write a variable from the MATLAB workspace into a NetCDF file
- Low-level access functions provide interfaces to dozens of functions in the NetCDF library

---

**Note** For information about MATLAB support for the Common Data Format (CDF), which is a completely separate and incompatible format, see `cdflib`.

---

### High-Level Access

These functions provide high-level access to NetCDF files.

<code>nccreate</code>	Create variable in NetCDF file
<code>ncinfo</code>	Return information about NetCDF data source
<code>ncread</code>	Read data from variable in NetCDF data source
<code>ncreadatt</code>	Read attribute value from NetCDF data source
<code>ncwrite</code>	Write data to NetCDF file
<code>ncwriteatt</code>	Write attribute to NetCDF file
<code>ncwritescema</code>	Add NetCDF schema definitions to NetCDF file

## Low-Level Access

The MATLAB low-level functions provide an API that you can use to enable reading data from and writing data to NetCDF files (known as *data sets* in NetCDF terminology). To use these functions, you should be familiar with the information about NetCDF contained in the [NetCDF C Interface Guide](#).

MATLAB supports NetCDF version 4.1.3.

In most cases, the syntax of the MATLAB function matches the syntax of the NetCDF library function. The functions are implemented as a package called `netcdf`. To use these functions, prefix the function name with package name `netcdf`. For example, to call the NetCDF library routine used to open existing NetCDF files, use the following MATLAB syntax:

```
ncid = netcdf.open(ncfile, mode);
```

## Library Functions

<code>netcdf</code>	Summary of MATLAB Network Common Data Form (NetCDF) capabilities
<code>netcdf.getChunkCache</code>	Retrieve chunk cache settings for NetCDF library
<code>netcdf.inqLibVers</code>	Return NetCDF library version information
<code>netcdf.setChunkCache</code>	Set default chunk cache settings for NetCDF library
<code>netcdf.setDefaultFormat</code>	Change default netCDF file format

## File Operations

<code>netcdf.abort</code>	Revert recent netCDF file definitions
<code>netcdf.close</code>	Close netCDF file

---

netcdf.create	Create new NetCDF dataset
netcdf.endDef	End netCDF file define mode
netcdf.inq	Return information about netCDF file
netcdf.inqFormat	Determine format of NetCDF file
netcdf.inqGrps	Retrieve array of child group IDs
netcdf.inqUnlimDims	Return list of unlimited dimensions in group
netcdf.open	Open NetCDF data source
netcdf.reDef	Put open netCDF file into define mode
netcdf.setFill	Set netCDF fill mode
netcdf.sync	Synchronize netCDF file to disk

**Dimensions**

netcdf.defDim	Create netCDF dimension
netcdf.inqDim	Return netCDF dimension name and length
netcdf.inqDimID	Return dimension ID
netcdf.renameDim	Change name of netCDF dimension

**Variables**

netcdf.defVar	Create NetCDF variable
netcdf.defVarChunking	Define chunking behavior for NetCDF variable
netcdf.defVarDeflate	Define compression parameters for NetCDF variable
netcdf.defVarFill	Define fill parameters for NetCDF variable

<code>netcdf.defVarFletcher32</code>	Define checksum parameters for NetCDF variable
<code>netcdf.getVar</code>	Return data from netCDF variable
<code>netcdf.inqVar</code>	Information about variable
<code>netcdf.inqVarChunking</code>	Determine chunking settings for NetCDF variable
<code>netcdf.inqVarDeflate</code>	Determine compression settings for NetCDF variable
<code>netcdf.inqVarFill</code>	Determine values of fill parameters for NetCDF variable
<code>netcdf.inqVarFletcher32</code>	Fletcher32 checksum setting for NetCDF variable
<code>netcdf.inqVarID</code>	Return ID associated with variable name
<code>netcdf.putVar</code>	Write data to netCDF variable
<code>netcdf.renameVar</code>	Change name of netCDF variable
<b>Attributes</b>	
<code>netcdf.copyAtt</code>	Copy attribute to new location
<code>netcdf.delAtt</code>	Delete netCDF attribute
<code>netcdf.getAtt</code>	Return netCDF attribute
<code>netcdf.inqAtt</code>	Return information about netCDF attribute
<code>netcdf.inqAttID</code>	Return ID of netCDF attribute
<code>netcdf.inqAttName</code>	Return name of netCDF attribute
<code>netcdf.putAtt</code>	Write netCDF attribute
<code>netcdf.renameAtt</code>	Change name of attribute



**Utilities**`netcdf.getConstant`

Return numeric value of named constant

`netcdf.getConstantNames`

Return list of constants known to netCDF library

# netcdf.abort

---

**Purpose** Revert recent netCDF file definitions

**Syntax** `netcdf.abort(ncid)`

**Description** `netcdf.abort(ncid)` reverts a netCDF file to its previous state, backing out any definitions made since the file last entered define mode. A file enters define mode when you create it (using `netcdf.create`) or when you explicitly enter define mode (using `netcdf.redef`). Once you leave define mode (using `netcdf.endDef`), you cannot revert the definitions you made while in define mode. `ncid` is a netCDF file identifier returned by `netcdf.create` or `netcdf.open`. A call to `netcdf.abort` closes the file.

This function corresponds to the `nc_abort` function in the netCDF library C API. To use this function, you should be familiar with the netCDF programming paradigm. See `netcdf` for more information.

**Examples** This example creates a new file, performs an operation on the file, and then reverts the file back to its original state. To run this example, you must have write permission in your current directory.

```
% Create a netCDF file
ncid = netcdf.create('foo.nc','NC_NOCLlobber');

% Perform an operation, such as defining a dimension.
dimid = netcdf.defDim(ncid, 'lat', 50);

% Revert the file back to its previous state.
netcdf.abort(ncid)

% Verify that the file is now closed.
dimid = netcdf.defDim(ncid, 'lat', 50); % should fail
??? Error using ==> netcdf.lib
NetCDF: Not a valid ID

Error in ==> defDim at 22
dimid = netcdf.lib('def_dim', ncid,dimname,dimlen);
```

## See Also

[netcdf.create](#) | [netcdf.endDef](#) | [netcdf.reDef](#)

# netcdf.close

---

**Purpose** Close netCDF file

**Syntax** `netcdf.close(ncid)`

**Description** `netcdf.close(ncid)` terminates access to the netCDF file identified by `ncid`.

`ncid` is a netCDF file identifier returned by `netcdf.create` or `netcdf.open`.

This function corresponds to the `nc_close` function in the netCDF library C API. To use this function, you should be familiar with the netCDF programming paradigm. See `netcdf` for more information.

**Examples** This example creates a new netCDF file, and then closes the file. You must have write permission in your current directory to run this example.

```
ncid = netcdf.open('foo.nc', 'NC_WRITE')
```

```
netcdf.close(ncid)
```

**See Also** `netcdf.create` | `netCDF.open`

<b>Purpose</b>	Copy attribute to new location
<b>Syntax</b>	<code>netcdf.copyAtt(ncid_in,varid_in,attname,ncid_out,varid_out)</code>
<b>Description</b>	<p><code>netcdf.copyAtt(ncid_in,varid_in,attname,ncid_out,varid_out)</code> copies an attribute from one variable to another, possibly across files. <code>ncid_in</code> and <code>ncid_out</code> are netCDF file identifiers returned by <code>netcdf.create</code> or <code>netcdf.open</code>. <code>varid_in</code> identifies the variable with an attribute that you want to copy. <code>varid_out</code> identifies the variable to which you want to associate a copy of the attribute.</p> <p>This function corresponds to the <code>nc_copy_att</code> function in the netCDF library C API. To use this function, you should be familiar with the netCDF programming paradigm. See <code>netcdf</code> for more information.</p>
<b>Examples</b>	<p>This example makes a copy of the attribute associated with the first variable in the netCDF example file, <code>example.nc</code>, in a new file. To run this example, you must have write permission in your current directory.</p> <pre>% Open example file. ncid = netcdf.open('example.nc','NC_NOWRITE');  % Get identifier for a variable in the file. varid = netcdf.inqVarID(ncid,'avagadros_number');  % Create new netCDF file. ncid2 = netcdf.create('foo.nc','NC_NOCLlobber');  % Define a dimension in the new file. dimid2 = netcdf.defDim(ncid2,'x',50);  % Define a variable in the new file. varid2 = netcdf.defVar(ncid2,'myvar','double',dimid2);  % Copy the attribute named 'description' into the new file, % associating the attribute with the new variable. netcdf.copyAtt(ncid,varid,'description',ncid2,varid2);</pre>

# netcdf.copyAtt

---

```
%
% Check the name of the attribute in new file.
attname = netcdf.inqAttName(ncid2,varid2,0)

attname =

description
```

## See Also

```
netcdf.inqAtt | netcdf.inqAttID | netcdf.inqAttName |
netcdf.putAtt | netcdf.renameAtt
```

**Purpose** Create new NetCDF dataset

**Syntax**

```
ncid = netcdf.create(filename,mode)
[chunksize_out,ncid] = netcdf.create(filename,mode,initasz,chunksize)
```

**Description** `ncid = netcdf.create(filename,mode)` creates a new NetCDF file according to the file creation mode. The return value `ncid` is a file ID. The mode parameter is a text string that describes the type of file access, which can have any of the following values.

Value	Description
NOCLOBBER	Prevent overwriting of existing file with the
CLOBBER	Overwrite any existing file with the same name.
SHARE	Allow synchronous file updates.
64BIT_OFFSET	Allow easier creation of files and variables which are larger than two gigabytes.
NETCDF4	Create a NetCDF-4/HDF5 file
CLASSIC_MODEL	Enforce the classic model; has no effect unless used in a bitwise-or with NETCDF4

**Note** You can specify the mode as a numeric value, retrieved using the `netcdf.getConstant` function. To specify more than one mode, use a bitwise-OR of the numeric values of the modes.

`[chunksize_out,ncid] = netcdf.create(filename,mode,initasz,chunksize)` creates a new netCDF file, but with additional performance tuning parameters. `initasz` sets the initial size of the file. `chunksize` can affect I/O performance. The actual value chosen by the NetCDF library might not correspond to the input value.

# netcdf.create

---

This function corresponds to the `nc_create` and `nc__create` functions in the NetCDF library C API. To use this function, you should be familiar with the netCDF programming paradigm. See `netcdf` for more information.

## Examples

This example creates a netCDF dataset named `foo.nc`, only if no other file with the same name exists in the current directory. To run this example, you must have write permission in your current directory.

```
ncid = netcdf.create('foo.nc', 'NOCLOBBER');
```

---

This example creates a netCDF-4 file that uses the classic model.

```
mode = netcdf.getConstant('NETCDF4');
mode = bitor(mode, netcdf.getConstant('CLASSIC_MODEL'));
ncid = netcdf.create('myfile.nc', mode);
netcdf.close(ncid);
```

## See Also

`netcdf.getConstant` | `netcdf.open`



<b>Purpose</b>	Create netCDF dimension
<b>Syntax</b>	<code>dimid = netcdf.defDim(ncid,dimname,dimlen)</code>
<b>Description</b>	<p><code>dimid = netcdf.defDim(ncid,dimname,dimlen)</code> creates a new dimension in the netCDF file specified by <code>ncid</code>, where <code>dimname</code> is a character string that specifies the name of the dimension and <code>dimlen</code> is a numeric value that specifies its length. To define an unlimited dimension, specify the predefined constant <code>'NC_UNLIMITED'</code> for <code>dimlen</code>, using <code>netcdf.getConstant</code> to retrieve the value.</p> <p><code>netcdf.defDim</code> returns <code>dimid</code>, a numeric ID corresponding to the new dimension.</p> <p>This function corresponds to the <code>nc_def_dim</code> function in the netCDF library C API. To use this function, you should be familiar with the netCDF programming paradigm. See <code>netcdf</code> for more information.</p> <p>For copyright information, read the <code>netcdfcopyright.txt</code> and <code>mexnccopyright.txt</code> files.</p>
<b>Examples</b>	<p>Create a new file and define two dimensions in the file. One dimension is an unlimited dimension. To run this example, you must have write permission in your current folder.</p> <pre>% Create a netCDF file. ncid = netcdf.create('foo.nc','NC_NOCLlobber')  % Define a dimension. lat_dimID = netcdf.defDim(ncid,'latitude',360);  % Define an unlimited dimension. long_dimID = netcdf.defDim(ncid,'longitude',...     netcdf.getConstant('NC_UNLIMITED'));</pre>
<b>See Also</b>	<code>netcdf.getConstant</code>

# netcdf.defGrp

---

<b>Purpose</b>	Create group in NetCDF file
<b>Syntax</b>	<code>childGrpID = netcdf.defGrp(parentGroupId,childGroupName)</code>
<b>Description</b>	<code>childGrpID = netcdf.defGrp(parentGroupId,childGroupName)</code> creates a child group with the name specified by <code>childGroupName</code> , that is the child of the parent group specified by <code>parentGroupId</code>
<b>Input Arguments</b>	<b>parentGroupId</b> Identifier of NetCDF file, returned by <code>netcdf.create</code> or <code>netcdf.open</code> , or of a NetCDF group, returned by <code>netcdf.defGrp</code> . <b>childGroupName</b> Text string specifying the name that you want to assign to the group.
<b>Output Arguments</b>	<b>childGrpID</b> Identifier of a NetCDF group.
<b>Examples</b>	This example creates a NetCDF dataset and then defines a group. <pre>ncid = netcdf.create('myfile.nc','netcdf4'); childGroupId = netcdf.defGrp(ncid,'mygroup'); netcdf.close(ncid);</pre>
<b>References</b>	This function corresponds to the <code>nc_def_grp</code> function in the NetCDF library C API. For copyright information, read the files <code>netcdfcopyright.txt</code> and <code>mexnccopyright.txt</code> .
<b>See Also</b>	<code>netcdf</code>   <code>netcdf.inqGrps</code>

<b>Purpose</b>	Create NetCDF variable
<b>Syntax</b>	<code>varid = netcdf.defVar(ncid,varname,xtype,dimids)</code>
<b>Description</b>	<p><code>varid = netcdf.defVar(ncid,varname,xtype,dimids)</code> creates a new variable in the dataset identified by <code>ncid</code>.</p> <p><code>varname</code> is a character string that specifies the name of the variable. <code>xtype</code> can be either a character string specifying the data type of the variable, such as <code>'double'</code>, or it can be the numeric equivalent returned by the <code>netcdf.getConstant</code> function. <code>dimids</code> specifies a list of dimension IDs.</p> <p><code>netcdf.defVar</code> returns <code>varid</code>, a numeric identifier for the new variable.</p> <p>This function corresponds to the <code>nc_def_var</code> function in the NetCDF library C API. Because MATLAB uses FORTRAN-style ordering, the fastest-varying dimension comes first and the slowest comes last. Any unlimited dimension is therefore last in the list of dimension IDs. This ordering is the reverse of that found in the C API. To use this function, you should be familiar with the netCDF programming paradigm. See <code>netcdf</code> for more information.</p>
<b>Examples</b>	<p>This example creates a new netCDF file, defines a dimension in the file, and then defines a variable on that dimension. (In netCDF files, you must create a dimension before you can create a variable.) To run this example, you must have write permission in your current directory.</p> <pre>% Create netCDF file. ncid = netcdf.create('foo.nc','NC_NOCLlobber'); % % Define a dimension in the new file. dimid = netcdf.defDim(ncid,'x',50);  % Define a variable in the new file. varid = netcdf.defVar(ncid,'myvar','double',dimid)</pre>
<b>See Also</b>	<code>netCDF.getConstant</code>   <code>netCDF.inqVar</code>   <code>netCDF.putVar</code>

# netcdf.defVarChunking

---

<b>Purpose</b>	Define chunking behavior for NetCDF variable
<b>Syntax</b>	<code>netcdf.defVarChunking(ncid,varid,storage,chunkDims)</code>
<b>Description</b>	<p><code>netcdf.defVarChunking(ncid,varid,storage,chunkDims)</code>. sets the chunk settings for the variable specified by <code>varid</code>. Chunking is a technique to improve performance. <code>storage</code> specifies the type of chunking to use and <code>chunkDims</code> specifies the extents of the chunk size. You must specify the chunk size used with a variable after creating the variable but before you write data to the variable.</p> <p>You cannot specify the chunk size for variables in a NetCDF file created with the netCDF-3 mode (<code>CLASSIC_MODEL</code>).</p>
<b>Input Arguments</b>	<p><b>ncid</b> Identifier of NetCDF file, returned by <code>netcdf.create</code> or <code>netcdf.open</code>, or of a NetCDF group, returned by <code>netcdf.defGrp</code>.</p> <p><b>varid</b> Identifier of a NetCDF variable, returned by <code>netcdf.defVar</code>.</p> <p><b>storage</b> Text string specifying whether NetCDF should break the variable into chunks when writing to a file. If set to <code>CHUNKED</code>, NetCDF breaks the variable into chunks; if set to <code>CONTIGUOUS</code>, NetCDF does not break the data into chunks.</p> <p><b>chunkDims</b> Array specifying the dimensions of the chunk. Because MATLAB uses FORTRAN-style ordering, the order of dimensions in <code>chunkdims</code> is reversed relative to what would be in the C API. If <code>storage</code> is <code>CONTIGUOUS</code>, you can omit <code>chunkDims</code>.</p>

**Default:** Chunk size determined by the NetCDF library.

## Examples

This example creates a NetCDF file and specifies the chunking behavior of a variable.

```
ncid = netcdf.create('myfile.nc', 'NETCDF4');
latdimid = netcdf.defDim(ncid, 'lat', 1800);
londimid = netcdf.defDim(ncid, 'col', 3600);
varid = netcdf.defVar(ncid, 'earthgrid', 'double', [latdimid londimid]);
netcdf.defVarChunking(ncid, varid, 'CHUNKED', [180 360]);
netcdf.close(ncid);
```

## References

This function corresponds to the `nc_def_var_chunking` function in the NetCDF library C API.

For copyright information, read the `netcdfcopyright.txt` and `mexncopyright.txt` files.

## See Also

`netcdf` | `netcdf.inqVarChunking`

# netcdf.defVarDeflate

---

<b>Purpose</b>	Define compression parameters for NetCDF variable
<b>Syntax</b>	<code>netcdf.defVarDeflate(ncid, varid, shuffle, deflate, deflateLevel)</code>
<b>Description</b>	<code>netcdf.defVarDeflate(ncid, varid, shuffle, deflate, deflateLevel)</code> sets the compression parameters for the NetCDF variable specified by <code>varid</code> in the location specified by <code>ncid</code> .
<b>Input Arguments</b>	<p><b>ncid</b> Identifier of NetCDF file, returned by <code>netcdf.create</code> or <code>netcdf.open</code>, or of a NetCDF group, returned by <code>netcdf.defGrp</code>.</p> <p><b>varid</b> Identifier of a NetCDF variable, returned by <code>netcdf.defVar</code>.</p> <p><b>shuffle</b> Boolean value. To turn on the shuffle filter, set this argument to <code>true</code>. The shuffle filter can assist with the compression of integer data by changing the byte order in the data stream.</p> <p><b>deflate</b> Boolean value. To turn on compression, set this argument to <code>true</code> and set the <code>deflateLevel</code> argument to the desired compression level.</p> <p><b>deflateLevel</b> Numeric value between 0 and 9 specifying the amount of compression, where 0 is no compression and 9 is the most compression.</p>

## Examples

This example create a variable with dimensions [1800 3600] and a compression level of 5. This results in a chunked layout that is a 10-by-10 grid.

```
ncid = netcdf.create('myfile.nc', 'NETCDF4');
latdimid = netcdf.defDim(ncid, 'lat', 1800);
```

```
londimid = netcdf.defDim(ncid,'col',3600);
varid = netcdf.defVar(ncid,'earthgrid','double',[latdimid londimid]);
netcdf.defVarDeflate(ncid,varid,true,true,5);
netcdf.close(ncid);
```

## References

This function corresponds to the `nc_def_var_deflate` function in the netCDF library C API.

For copyright information, read the `netcdfcopyright.txt` and `mexncopyright.txt` files.

## See Also

`netcdf` | `netcdf.inqVarDeflate`

# netcdf.defVarFill

---

**Purpose** Define fill parameters for NetCDF variable

**Syntax** `netcdf.defVarFill(ncid, varid, noFillMode, fillValue)`

**Description** `netcdf.defVarFill(ncid, varid, noFillMode, fillValue)` sets the fill parameters for the NetCDF variable identified by `varid`. `ncid` specifies the location.

For netCDF-4 files, you can only specify fill values when the NetCDF is in definition mode (before calling `netcdf.endDef`). For NetCDF files in classic and 64-bit offset modes, you can turn no-fill mode on and off at any time.

## Input Arguments

### **ncid**

Identifier of a NetCDF file, returned by `netcdf.create` or `netcdf.open`, or of a NetCDF group, returned by `netcdf.defGrp`.

### **varid**

Identifier of a NetCDF variable, returned by `netcdf.defVar`.

### **noFillMode**

Boolean value. When set to `true`, turns off use of fill values for the variable, which can be helpful in high performance applications. When `true`, `netcdf.defVarFill` ignores the value of the `fillValue` argument. To use the fill value, set this to `false`.

### **fillValue**

Specifies the value to use in the variable when no other value is specified. The data type must be the same data type as the variable.

## Examples

This example creates a NetCDF file and defines a fill value for a variable.

```
ncid = netcdf.create('myfile.nc', 'NETCDF4');
dimid = netcdf.defDim(ncid, 'latitude', 180);
```



```
varid = netcdf.defVar(ncid,'latitude','double',dimid);
netcdf.defVarFill(ncid,varid,false,-999);
netcdf.close(ncid);
```

## References

This function corresponds to the `nc_def_var_fill` function in the NetCDF library C API.

For copyright information, read the `netcdfcopyright.txt` and `mexnccopyright.txt` files.

## See Also

`netcdf` | `netcdf.setFill` | `netcdf.inqVarFill`

# netcdf.defVarFletcher32

---

<b>Purpose</b>	Define checksum parameters for NetCDF variable
<b>Syntax</b>	<code>netcdf.defVarFletcher32(ncid,varid,setting)</code>
<b>Description</b>	<code>netcdf.defVarFletcher32(ncid,varid,setting)</code> defines the checksum settings for the NetCDF variable specified by <code>varid</code> in the file specified by <code>ncid</code> .
<b>Input Arguments</b>	<p><b>ncid</b> Identifier of NetCDF file, returned by <code>netcdf.create</code> or <code>netcdf.open</code>, or of a NetCDF group, returned by <code>netcdf.defGrp</code>.</p> <p><b>varid</b> Identifier of a NetCDF variable, returned by <code>netcdf.defVar</code>.</p> <p><b>setting</b> Text string specifying whether Fletcher32 checksum error detection is used with the variable. To turn on Fletcher32 checksum, specify the value <code>FLETCHER32</code>. To turn off the use of checksum error detection, specify the value <code>NOCHECKSUM</code>.</p>
<b>Examples</b>	<p>This example creates a NetCDF dataset and turns on the Fletcher32 checksum for a variable.</p> <pre>ncid = netcdf.create('myfile.nc', 'NETCDF4'); latdimid = netcdf.defDim(ncid, 'lat', 1800); londimid = netcdf.defDim(ncid, 'col', 3600); varid = netcdf.defVar(ncid, 'earthgrid', 'double', [latdimid londimid]); netcdf.defVarFletcher32(ncid, varid, 'FLETCHER32'); netcdf.close(ncid);</pre>
<b>References</b>	This function corresponds to the <code>nc_def_var_fletcher32</code> function in the NetCDF library C API.

For copyright information, read the files `netcdfcopyright.txt` and `mexnccopyright.txt`.

### **See Also**

`netcdf` | `netcdf.inqVarFletcher32`

# netcdf.delAtt

---

**Purpose** Delete netCDF attribute

**Syntax** `netcdf.delAtt(ncid,varid,attName)`

**Description** `netcdf.delAtt(ncid,varid,attName)` deletes the attribute identified by the text string `attName`.

`ncid` is a netCDF file identifier returned by `netcdf.create` or `netcdf.open`.

`varid` is a numeric value that identifies the variable. To delete a global attribute, use `netcdf.getConstant('GLOBAL')` for the `varid`. You must be in define mode to delete an attribute.

This function corresponds to the `nc_del_att` function in the netCDF library C API. To use this function, you should be familiar with the netCDF programming paradigm. See `netcdf` for more information.

**Examples** This example opens a local copy of the example netCDF file included with MATLAB, `example.nc`.

```
% Open a netCDF file.
ncid = netcdf.open('my_example.nc','NC_WRITE')

% Determine number of global attributes in file.
[numdims numvars numatts unlimdimID] = netcdf.inq(ncid);

numatts =

 1

% Get name of attribute; it is needed for deletion.
attname = netcdf.inqAttName(ncid,netcdf.getConstant('NC_GLOBAL'),0)

% Put file in define mode to delete an attribute.
netcdf.reDef(ncid);

% Delete the global attribute in the netCDF file.
```

```
netcdf.delAtt(ncid,netcdf.getConstant('GLOBAL'),attname);

% Verify that the global attribute was deleted.
[numdims numvars numatts unlimdimID] = netcdf.inq(ncid);

numatts =

 0
```

## See Also

[netcdf.getConstant](#) | [netcdf.inqAttName](#)

# netcdf.endDef

---

**Purpose** End netCDF file define mode

**Syntax** `netcdf.endDef(ncid)`  
`netcdf.endDef(ncid,h_minfree,v_align,v_minfree,r_align)`

**Description** `netcdf.endDef(ncid)` takes a netCDF file out of define mode and into data mode. `ncid` is a netCDF file identifier returned by `netcdf.create` or `netcdf.open`.

`netcdf.endDef(ncid,h_minfree,v_align,v_minfree,r_align)` takes a netCDF file out of define mode, specifying four additional performance tuning parameters. For example, one reason for using the performance parameters is to reserve extra space in the netCDF file header using the `h_minfree` parameter:

```
ncid = netcdf.endDef(ncid,20000,4,0,4);
```

This reserves 20,000 bytes in the header, which can be used later when adding attributes. This can be extremely efficient when working with very large netCDF 3 files. To understand how to use these performance tuning parameters, see the netCDF library documentation.

This function corresponds to the `nc_enddef` and `nc__enddef` functions in the netCDF library C API. To use this function, you should be familiar with the netCDF programming paradigm. See `netcdf` for more information.

## Examples **Take File out of Define Mode**

When you create a file using `netcdf.create`, the functions opens the file in define mode. This example uses `netcdf.endDef` to take the file out of define mode.

Create a netCDF file.

```
ncid = netcdf.create('foo.c','NC_NOCLlobber');
```

Define a dimension.

```
dimid = netcdf.defDim(ncid,'lat',50);
```

Leave define mode.

```
netcdf.endDef(ncid)
```

Test if still in define mode.

```
dimid = netcdf.defDim(ncid,'lon',50);
```

Error using netcdflib

```
The NetCDF library encountered an error during execution of 'defDim' t
(NC_ENOTINDEFINE)'.
Error in netcdf.defDim (line 25)
dimid = netcdfdeflib('defDim', ncid,dimname,dimlen);
```

netcdf.defDim errors, as expected.

## See Also

[netcdf.create](#) | [netcdf.reDef](#)

# netcdf.getAtt

---

**Purpose** Return netCDF attribute

**Syntax**  
`attrvalue = netcdf.getAtt(ncid,varid,attname)`  
`attrvalue = netcdf.getAtt(ncid,varid,attname,output_datatype)`

**Description** `attrvalue = netcdf.getAtt(ncid,varid,attname)` returns `attrvalue`, the value of the attribute specified by the text string `attname`. When it chooses the data type of `attrvalue`, MATLAB attempts to match the netCDF class of the attribute. For example, if the attribute has the netCDF data type `NC_INT`, MATLAB uses the `int32` class for the output data. If an attribute has the netCDF data type `NC_BYTE`, the class of the output data is `int8` value.

`attrvalue = netcdf.getAtt(ncid,varid,attname,output_datatype)` returns `attrvalue`, the value of the attribute specified by the text string `attname`, using the output class specified by `output_datatype`. You can specify any of the following strings for the output data type.

'int'	'double'	'int16'
'short'	'single'	'int8'
'float'	'int32'	'uint8'

This function corresponds to several attribute I/O functions in the netCDF library C API. To use this function, you should be familiar with the netCDF programming paradigm. See `netcdf` for more information.

**Examples** This example opens the example netCDF file included with MATLAB, `example.nc`, and gets the value of the attribute associated with the first variable. The example also gets the value of the global variable in the file.

```
% Open a netCDF file.
ncid = netcdf.open('example.nc','NC_NOWRITE');

% Get name of first variable.
```



```
[varname vartype vardimIDs varatts] = netcdf.inqVar(ncid,0);

% Get ID of variable, given its name.
varid = netcdf.inqVarID(ncid,varname);

% Get attribute name, given variable id.
attname = netcdf.inqAttName(ncid,varid,0);

% Get value of attribute.
attval = netcdf.getAtt(ncid,varid,attname);

% Get name of global attribute
gattname = netcdf.inqAttName(ncid,netcdf.getConstant('NC_GLOBAL'),0);

% Get value of global attribute.
gattval = netcdf.getAtt(ncid,netcdf.getConstant('NC_GLOBAL'),gattname);

gattval =

09-Jun-2008
```

## See Also

[netcdf.inqAtt](#) | [netcdf.putAtt](#)

# netcdf.getChunkCache

---

<b>Purpose</b>	Retrieve chunk cache settings for NetCDF library
<b>Syntax</b>	<code>[csize, nelems, premp] = netcdf.getChunkCache()</code>
<b>Description</b>	<code>[csize, nelems, premp] = netcdf.getChunkCache()</code> returns the default chunk cache settings.
<b>Output Arguments</b>	<p><b>csize</b></p> <p>Scalar double specifying the total size of the raw data chunk cache in bytes.</p> <p><b>nelems</b></p> <p>Scalar double specifying the number of chunk slots in the raw data chunk cache hash table.</p> <p><b>premp</b></p> <p>Double, between 0 and 1, inclusive, that specifies how the library handles preempting fully read chunks in the chunk cache. A value of zero means fully read chunks are treated no differently than other chunks, that is, preemption occurs solely based on the Least Recently Used (LRU) algorithm. A value of 1 means fully read chunks are always preempted before other chunks.</p>
<b>Examples</b>	<p>Determine information about the chunk cache size used by the NetCDF library.</p> <pre>[csize, nelems, premp] = netcdf.getChunkCache();</pre>
<b>References</b>	<p>This function corresponds to the <code>nc_get_chunk_cache</code> function in the NetCDF library C API.</p> <p>For copyright information, read the <code>netcdfcopyright.txt</code> and <code>mexnccopyright.txt</code> files.</p>
<b>See Also</b>	<code>netcdf</code>   <code>netcdf.setChunkCache</code>

**Purpose** Return numeric value of named constant

**Syntax** `val = netcdf.getConstant(param_name)`

**Description** `val = netcdf.getConstant(param_name)` returns the numeric value corresponding to the name of a constant defined by the netCDF library. For example, `netcdf.getConstant('NC_NOCLOBBER')` returns the numeric value corresponding to the netCDF constant `NC_NOCLOBBER`.

The value for `param_name` can be either upper- or lowercase, and does not need to include the leading three characters `'NC_'`. To retrieve a list of all the names defined by the netCDF library, use the `netcdf.getConstantNames` function.

This function has no direct equivalent in the netCDF C interface. To find out more about NetCDF, see `netcdf`.

**Examples** This example opens the example netCDF file included with MATLAB, `example.nc`.

```
% Open example file.
ncid = netcdf.open('example.nc','NC_NOWRITE');

% Determine contents of the file.
[ndims nvars natts dimm] = netcdf.inq(ncid);

% Get name of global attribute.
% Note: You must use netcdf.getConstant to specify NC_GLOBAL.
attname = netcdf.inqattname(ncid,netcdf.getConstant('NC_GLOBAL'),0)

attname =

creation_date
```

**See Also** `netcdf.getConstantNames`

# netcdf.getConstantNames

---

**Purpose** Return list of constants known to netCDF library

**Syntax** `val = netcdf.getConstantNames(param_name)`

**Description** `val = netcdf.getConstantNames(param_name)` returns a list of names of netCDF library constants, definitions, and enumerations. When these strings are supplied as actual parameters to MATLAB netCDF package functions, the functions automatically convert the constant to the appropriate numeric value.

This MATLAB function has no direct equivalent in the netCDF C interface. To find out more about netCDF, see `netcdf`.

**Examples** `nc_constants = netcdf.getConstantNames`

```
nc_constants =

 'NC2_ERR'
 'NC_64BIT_OFFSET'
 'NC_BYTE'
 'NC_CHAR'
 'NC_CLOBBER'
 'NC_DOUBLE'
 'NC_EBADDIM'
 'NC_EBADID'
 'NC_EBADNAME'
 'NC_EBADTYPE'
 ...
```

**See Also** `netCDF.getConstantNames`

**Purpose**

Return data from netCDF variable

**Syntax**

```
data = netcdf.getVar(ncid,varid)
data = netcdf.getVar(ncid,varid,start)
data = netcdf.getVar(ncid,varid,start,count)
data = netcdf.getVar(ncid,varid,start,count,stride)
data = netcdf.getVar(...,output_type)
```

**Description**

`data = netcdf.getVar(ncid,varid)` returns `data`, the value of the variable specified by `varid`. MATLAB attempts to match the class of the output data to netCDF class of the variable.

`ncid` is a netCDF file identifier returned by `netcdf.create` or `netcdf.open`.

`data = netcdf.getVar(ncid,varid,start)` returns a single value starting at the specified index, `start`.

`data = netcdf.getVar(ncid,varid,start,count)` returns a contiguous section of a variable. `start` specifies the starting point and `count` specifies the amount of data to return.

`data = netcdf.getVar(ncid,varid,start,count,stride)` returns a subset of a section of a variable. `start` specifies the starting point, `count` specifies the extent of the section, and `stride` specifies which values to return.

`data = netcdf.getVar(...,output_type)` specifies the data type of the return value `data`. You can specify any of the following strings for the output data type.

'int8'
--------

'uint8'
---------

'int16'
---------

'int32'
---------

'single'
----------

'double'
----------

# netcdf.getVar

---

This function corresponds to several functions in the netCDF library C API. To use this function, you should be familiar with the netCDF programming paradigm. See `netcdf` for more information.

## Examples

Open the example netCDF file and get the value of a variable in the file.

```
% Open example file.
ncid = netcdf.open('example.nc', 'NC_NOWRITE');

% Get the name of the first variable.
[varname, xtype, varDimIDs, varAtts] = netcdf.inqVar(ncid,0);

% Get variable ID of the first variable, given its name.
varid = netcdf.inqVarID(ncid,varname);

% Get the value of the first variable, given its ID.
data = netcdf.getVar(ncid,varid)

data =

 6.0221e+023

% Determine the data type of the output value
whos data
 Name Size Bytes Class Attributes
 data 1x1 8 double

% Get the value again, this time specifying the output data type
data = netcdf.getVar(ncid,varid,'single');

% Determine the data type of the output value
whos data
 Name Size Bytes Class Attributes
 data 1x1 4 single
```

**See Also**

[netcdf.create](#) | [netcdf.inqVarID](#) | [netcdf.open](#)

# netcdf.inq

---

**Purpose** Return information about netCDF file

**Syntax** `[ndims,nvars,ngatts,unlimdimid] = netcdf.inq(ncid)`

**Description** `[ndims,nvars,ngatts,unlimdimid] = netcdf.inq(ncid)` returns the number of dimensions, variables, and global attributes in a netCDF file. The function also returns the ID of the dimension defined with unlimited length, if one exists.

`ncid` is a netCDF file identifier returned by `netcdf.create` or `netcdf.open`. You can call `netcdf.inq` in either define mode or data mode.

This function corresponds to the `nc_inq` function in the netCDF library C API. To use this function, you should be familiar with the netCDF programming paradigm. See `netcdf` for more information.

**Examples** This example opens the example netCDF file included with MATLAB, `example.nc`, and uses the `netcdf.inq` function to get information about the contents of the file.

```
% Open netCDF example file.
ncid = netcdf.open('example.nc','NC_NOWRITE')

% Get information about the contents of the file.
[numdims, numvars, numglobalatts, unlimdimID] = netcdf.inq(ncid)

numdims =

 4

numvars =

 4

numglobalatts =
```



1

unlimdimID =

3

**See Also**

`netcdf.create` | `netcdf.open`

# netcdf.inqDimIDs

---

**Purpose** Retrieve list of dimension identifiers in group

**Syntax**  
`dimIDs = netcdf.inqDimIDs(ncid)`  
`dimIDs = netcdf.inqDimIDs(ncid,includeParents)`

**Description**  
`dimIDs = netcdf.inqDimIDs(ncid)` returns a list of dimension identifiers in the group specified by `ncid`.  
`dimIDs = netcdf.inqDimIDs(ncid,includeParents)` includes all dimensions in all parent groups if `includeParents` is true.

**Input Arguments**  
**ncid**  
Identifier of a NetCDF file, returned by `netcdf.create` or `netcdf.open`, or of a NetCDF group, returned by `netcdf.defGrp`.

**includeParents**  
Boolean value. If set to true, `netcdf.inqDimIDs` includes the dimensions of all parent groups.

**Default:** false

**Output Arguments**  
**dimIDs**  
Array of dimension IDs

**Examples**  
This example opens the NetCDF sample file and gets the IDs of all the dimensions.

```
ncid = netcdf.open('example.nc','NOWRITE');
gid = netcdf.inqNcid(ncid,'grid1');
dimids = netcdf.inqDimIDs(gid);
dimids_all = netcdf.inqDimIDS(gid, true);
netcdf.close(ncid);
```

**References**  
This function corresponds to the `nc_inq_dimids` function in the NetCDF library C API.

For copyright information, read the `netcdfcopyright.txt` and `mexnccopyright.txt` files.

## See Also

`netcdf` | `netcdf.inqVarIDs`

# netcdf.inqFormat

---

**Purpose** Determine format of NetCDF file

**Syntax** `format = netcdf.inqFormat(ncid)`

**Description** `format = netcdf.inqFormat(ncid)` returns the format for the file specified by NetCDF file identifier, `ncid`.

**Input Arguments** **ncid**  
Identifier of a NetCDF file, returned by `netcdf.create` or `netcdf.open`, or of a NetCDF group, returned by `netcdf.defGrp`.

**Output Arguments** **format**  
Text string that specifies the format of the NetCDF file. Values include:

Format String	Description
FORMAT_CLASSIC	Classic format — Original NetCDF format, used by all NetCDF files created between 1989 and 2004
FORMAT_64BIT	Classic format, 64-bit — Original format with 64-bit addressing capability to allow creation and access of much larger files.
FORMAT_NETCDF4	Enhanced model, HDF5-based — Introduced in 2008, NetCDF, version 4, extends the classic model and is based on HDF5.
FORMAT_NETCDF4_CLASSIC	Classic model, HDF5-based — Introduced in 2008, NetCDF, version 4, implements classic model but is based on HDF5.

**Examples** This example opens the sample NetCDF file and determines the format.

```
ncid = netcdf.open('example.nc', 'NOWRITE');
fmt = netcdf.inqFormat(ncid)
```

```
format =
FORMAT_NETCDF4
netcdf.close(ncid);
```

## References

This function corresponds to the `nc_inq_format` function in the NetCDF library C API.

For copyright information, read the `netcdfcopyright.txt` and `mexnccopyright.txt` files.

## See Also

`netcdf.getConstant` | `netcdf`

# netcdf.inqGrpName

---

<b>Purpose</b>	Retrieve name of group
<b>Syntax</b>	<code>groupName = netcdf.inqGrpName(ncid)</code>
<b>Description</b>	<code>groupName = netcdf.inqGrpName(ncid)</code> returns the name of a group specified by <code>ncid</code> .
<b>Input Arguments</b>	<b>ncid</b> Identifier of NetCDF file, returned by <code>netcdf.create</code> or <code>netcdf.open</code> , or of a NetCDF group, returned by <code>netcdf.defGrp</code> .
<b>Output Arguments</b>	<b>groupName</b> Text string specifying name of a group. The root group has the name <code>'/'</code> .
<b>Examples</b>	This example opens the NetCDF sample file and gets the names of groups in the dataset. <pre>ncid = netcdf.open('example.nc','nowrite'); name = netcdf.inqGrpName(ncid); netcdf.close(ncid);</pre>
<b>References</b>	This function corresponds to the <code>nc_inq_grpname</code> function in the NetCDF library C API. For copyright information, read the <code>netcdfcopyright.txt</code> and <code>mexnccopyright.txt</code> files.
<b>See Also</b>	<code>netcdf</code>   <code>netcdf.inqGrpNameFull</code>

<b>Purpose</b>	Complete pathname of group
<b>Syntax</b>	<code>groupName = netcdf.inqGrpNameFull(ncid)</code>
<b>Description</b>	<code>groupName = netcdf.inqGrpNameFull(ncid)</code> returns the complete pathname of the group specified by <code>ncid</code> .
<b>Input Arguments</b>	<b>ncid</b> Identifier of NetCDF file, returned by <code>netcdf.create</code> or <code>netcdf.open</code> , or of a NetCDF group, returned by <code>netcdf.defGrp</code> .
<b>Output Arguments</b>	<b>groupName</b> Text string specifying complete path of group.  The root group has the name <code>'/'</code> . The names of parent groups and child groups use the forward slash <code>'/'</code> separator, as in UNIX folder names, for example, <code>/group1/subgrp2/subsubgrp3</code> .
<b>Examples</b>	Open the NetCDF sample dataset and retrieve the names of all groups.  <pre>ncid = netcdf.open('example.nc', 'NOWRITE'); gid = netcdf.inqNcid(ncid, 'grid2'); fullName = netcdf.inqGrpNameFull(gid); netcdf.close(ncid);</pre>
<b>References</b>	This function corresponds to the <code>nc_inq_grpname_full</code> function in the netCDF library C API.  For copyright information, read the <code>netcdfcopyright.txt</code> and <code>mexnccopyright.txt</code> files.
<b>See Also</b>	<code>netcdf</code>   <code>netcdf.inqGrpName</code>

# netcdf.inqGrpParent

---

<b>Purpose</b>	Retrieve ID of parent group.
<b>Syntax</b>	<code>parentGroupID = netcdf.inqGrpParent(ncid)</code>
<b>Description</b>	<code>parentGroupID = netcdf.inqGrpParent(ncid)</code> returns the ID of the parent group given the location of the child group, specified by <code>ncid</code> .
<b>Input Arguments</b>	<b>ncid</b> Identifier of a NetCDF file, returned by <code>netcdf.create</code> or <code>netcdf.open</code> , or of a NetCDF group, returned by <code>netcdf.defGrp</code> .
<b>Output Arguments</b>	<b>parentGroupID</b> Identifier of the NetCDF group or file that is the parent of the specified file or group.
<b>Examples</b>	<p>This example opens the NetCDF sample file and gets the full path of the parent of the specified group.</p> <pre>ncid = netcdf.open('example.nc', 'NOWRITE'); gid = netcdf.inqNcid(ncid, 'grid2'); parentId = netcdf.inqGrpParent(gid); fullName = netcdf.inqGrpNameFull(parentId); netcdf.close(ncid);</pre>
<b>References</b>	<p>This function corresponds to the <code>nc_inq_grp_parent</code> function in the NetCDF library C API.</p> <p>For copyright information, read the <code>netcdfcopyright.txt</code> and <code>mexnccopyright.txt</code> files.</p>
<b>See Also</b>	<code>netcdf</code>   <code>netcdf.inqGrps</code>



<b>Purpose</b>	Retrieve array of child group IDs
<b>Syntax</b>	<code>childGrps = netcdf.inqGrps(ncid)</code>
<b>Description</b>	<code>childGrps = netcdf.inqGrps(ncid)</code> returns all the child group IDs in the parent group, specified by <code>ncid</code> .
<b>Input Arguments</b>	<b>ncid</b> Identifier of NetCDF file, returned by <code>netcdf.create</code> or <code>netcdf.open</code> , or of a NetCDF group, returned by <code>netcdf.defGrp</code> .
<b>Output Arguments</b>	<b>childGrps</b> Array containing identifiers of child groups in the specified NetCDF file or group.
<b>Examples</b>	This example opens the sample NetCDF file and then gets information about the groups it contains. <pre>ncid = netcdf.open('example.nc', 'nowrite'); childGroups = netcdf.inqGrps(ncid); netcdf.close(ncid);</pre>
<b>References</b>	This function corresponds to the <code>nc_inq_grps</code> function in the netCDF library C API. For copyright information, read the <code>netcdfcopyright.txt</code> and <code>mexnccopyright.txt</code> files.
<b>See Also</b>	<code>netcdf</code>   <code>netcdf.inqNcid</code>

# netcdf.inqNcid

---

<b>Purpose</b>	Return ID of named group
<b>Syntax</b>	<code>childGroupId = netcdf.inqNcid(ncid,childGroupName)</code>
<b>Description</b>	<code>childGroupId = netcdf.inqNcid(ncid,childGroupName)</code> returns the ID of the child group, specified by the name <code>childGroupName</code> , in the file or group specified by <code>ncid</code> .
<b>Input Arguments</b>	<b>ncid</b> Identifier of a NetCDF file, returned by <code>netcdf.create</code> or <code>netcdf.open</code> , or of a NetCDF group, returned by <code>netcdf.defGrp</code> . <b>childGroupName</b> Text string specifying the name of a NetCDF group.
<b>Output Arguments</b>	<b>childGroupID</b> Identifier of a NetCDF group.
<b>Examples</b>	This example opens the sample NetCDF dataset and then gets the ID of a group in the dataset. <pre>ncid = netcdf.open('example.nc','nowrite'); gid = netcdf.inqNcid(ncid,'grid1'); netcdf.close(ncid);</pre>
<b>References</b>	This function corresponds to the <code>nc_inq_ncid</code> function in the netCDF library C API. Read the files <code>netcdfcopyright.txt</code> and <code>mexnccopyright.txt</code> for more information.
<b>See Also</b>	<code>netcdf</code>   <code>netcdf.inqGrpName</code>   <code>netcdf.inqGrpNameFull</code>

<b>Purpose</b>	Return list of unlimited dimensions in group
<b>Syntax</b>	<code>unlimdimIDs = netcdf.inqUnlimDims(ncid)</code>
<b>Description</b>	<code>unlimdimIDs = netcdf.inqUnlimDims(ncid)</code> returns the IDs of all unlimited dimensions in the group specified by <code>ncid</code> .
<b>Input Arguments</b>	<b>ncid</b> Identifier of a NetCDF file, returned by <code>netcdf.create</code> or <code>netcdf.open</code> , or group, returned by <code>netcdf.defGrp</code> .
<b>Output Arguments</b>	<b>unlimDimIDs</b> An array containing the identifiers of each unlimited dimension. <code>unlimDimIDs</code> is empty if there are no unlimited dimensions.
<b>Examples</b>	<p>This example opens the NetCDF sample dataset and gets the IDs of all the unlimited dimensions.</p> <pre>ncid = netcdf.open('example.nc', 'NOWRITE'); dimids = netcdf.inqUnlimDims(ncid)  dimids =       []  netcdf.close(ncid);</pre>
<b>References</b>	<p>This function corresponds to the <code>nc_inq_unlim_dims</code> function in the NetCDF library C API.</p> <p>For copyright information, read the <code>netcdfcopyright.txt</code> and <code>mexnccopyright.txt</code> files.</p>
<b>See Also</b>	<code>netcdf</code>   <code>netcdf.defDim</code>   <code>netcdf.inqDim</code>   <code>netcdf.inqDimID</code>   <code>netcdf.renameDim</code>   <code>netcdf.inqDimIDs</code>

# netcdf.inqVarIDs

---

<b>Purpose</b>	IDs of all variables in group
<b>Syntax</b>	<code>varids = netcdf.inqVarIDs(ncid)</code>
<b>Description</b>	<code>varids = netcdf.inqVarIDs(ncid)</code> returns IDs of the all the variables in the group specified by <code>ncid</code> .
<b>Input Arguments</b>	<b>ncid</b> Identifier of NetCDF file, returned by <code>netcdf.create</code> or <code>netcdf.open</code> , or of a NetCDF group, returned by <code>netcdf.defGrp</code> .
<b>Output Arguments</b>	<b>varids</b> Array containing identifiers of variables in a NetCDF file or group.
<b>Examples</b>	This example opens the NetCDF sample file and gets the IDs of all the variables in a group. <pre>ncid = netcdf.open('example.nc', 'NOWRITE'); gid = netcdf.inqNcid(ncid, 'grid1'); varids = netcdf.inqVarIDs(gid); netcdf.close(ncid);</pre>
<b>References</b>	This function corresponds to the <code>nc_inq_varids</code> function in the NetCDF library C API. For copyright information, read the <code>netcdfcopyright.txt</code> and <code>mexnccopyright.txt</code> files.
<b>See Also</b>	<code>netcdf</code>   <code>netcdf.inqDimIDs</code>   <code>netcdf.inqVarID</code>

<b>Purpose</b>	Determine chunking settings for NetCDF variable
<b>Syntax</b>	<code>[storage,chunkSizes] = netcdf.inqVarChunking(ncid,varid)</code>
<b>Description</b>	<code>[storage,chunkSizes] = netcdf.inqVarChunking(ncid,varid)</code> returns the type of chunking and the dimensions of a chunk for the NetCDF variable specified by <code>varid</code> , in the file or group specified by <code>ncid</code> .
<b>Input Arguments</b>	<b>ncid</b> Identifier of NetCDF file, returned by <code>netcdf.create</code> or <code>netcdf.open</code> , or of a NetCDF group, returned by <code>netcdf.defGrp</code> .  <b>varid</b> Identifier of NetCDF variable, returned by <code>netcdf.defVar</code> .
<b>Output Arguments</b>	<b>storage</b> Text string specifying if NetCDF breaks the data into chunks when writing to a file. <code>CHUNKED</code> indicates the data is chunked; <code>CONTIGUOUS</code> indicates that the data is not chunked.  <b>chunkSizes</b> Array specifying the dimensions of the chunk.  Because MATLAB uses FORTRAN-style ordering, the order of dimensions in <code>chunkdims</code> is reversed relative to what would be in the NetCDF C API.  If the storage type specified is <code>CONTIGUOUS</code> , <code>netcdf.inqVarChunking</code> returns an empty array, <code>[]</code> .
<b>Examples</b>	This example opens the NetCDF sample dataset and gets the values of chunking parameters associated with a variable.  <pre>ncid = netcdf.open('example.nc','NOWRITE');</pre>

# netcdf.inqVarChunking

---

```
groupid = netcdf.inqNcid(ncid,'grid1');
varid = netcdf.inqVarID(groupid,'temp');
[storage,chunkSize] = netcdf.inqVarChunking(groupid,varid);
netcdf.close(ncid);
```

## References

This function corresponds to the `nc_inq_var_chunking` function in the netCDF library C API.

For copyright information, read the `netcdfcopyright.txt` and `mexnccopyright.txt` files.

## See Also

`netcdf` | `netcdf.defVar` | `netcdf.defVarChunking`

<b>Purpose</b>	Determine compression settings for NetCDF variable
<b>Syntax</b>	<code>[shuffle,deflate,deflateLevel] = netcdf.inqVarDeflate(ncid,varid)</code>
<b>Description</b>	<code>[shuffle,deflate,deflateLevel] = netcdf.inqVarDeflate(ncid,varid)</code> returns the compression parameters for the NetCDF variable specified by <code>varid</code> in the location specified by <code>ncid</code> .
<b>Input Arguments</b>	<p><b>ncid</b> Identifier of a NetCDF file, returned by <code>netcdf.create</code> or <code>netcdf.open</code>, or of a NetCDF group, returned by <code>netcdf.defGrp</code>.</p> <p><b>varid</b> Identifier of NetCDF variable, returned by <code>netcdf.defVar</code>.</p>
<b>Output Arguments</b>	<p><b>shuffle</b> Boolean value. <code>true</code> indicates that the shuffle filter is enabled for the specified variable. The shuffle filter can assist with the compression of integer data by changing the byte order in the data stream.</p> <p><b>deflate</b> Boolean value. <code>true</code> indicates that compression is enabled for this variable. The <code>deflateLevel</code> argument specifies the level of compression.</p> <p><b>deflateLevel</b> Scalar value between 0 and 9 specifying the amount of compression, where 0 is no compression and 9 is the most compression</p>
<b>Examples</b>	<p>This example opens the NetCDF sample file and gets information about variable compression.</p> <pre>ncid = netcdf.open('example.nc','NOWRITE');</pre>

# netcdf.inqVarDeflate

---

```
groupid = netcdf.inqNcid(ncid,'grid1');
varid = netcdf.inqVarID(groupid,'temp');
[shuffle,deflate,deflateLevel] = netcdf.inqVarDeflate(groupid,varid);
netcdf.close(ncid);
```

## References

This function corresponds to the `nc_inq_var_deflate` function in the netCDF library C API.

For copyright information, read the `netcdfcopyright.txt` and `mexnccopyright.txt` files.

## See Also

`netcdf` | `netcdf.defVarDeflate`



<b>Purpose</b>	Determine values of fill parameters for NetCDF variable
<b>Syntax</b>	<code>[noFillMode,fillValue] = netcdf.inqVarFill(ncid,varid)</code>
<b>Description</b>	<code>[noFillMode,fillValue] = netcdf.inqVarFill(ncid,varid)</code> returns the fill mode and the fill value for the variable <code>varid</code> in the file or group specified by <code>ncid</code> .
<b>Input Arguments</b>	<b>ncid</b> Identifier of a NetCDF file, returned by <code>netcdf.create</code> or <code>netcdf.open</code> , or a NetCDF group, returned by <code>netcdf.defGrp</code> .  <b>varid</b> Identifier of NetCDF variable.
<b>Output Arguments</b>	<b>noFillMode</b> Boolean value. <code>true</code> indicates that use of the fill values for the variable has been disabled.  <b>fillValue</b> Specifies the value to use in the variable when no other value is specified and use of fill values has been enabled.
<b>Examples</b>	This example opens the NetCDF sample dataset and gets the fill mode and fill value used with a variable.  <pre>ncid = netcdf.open('example.nc','NOWRITE'); varid = netcdf.inqVarID(ncid,'temperature'); [noFillMode,fillValue] = netcdf.inqVarFill(ncid,varid); netcdf.close(ncid);</pre>
<b>References</b>	This function corresponds to the <code>nc_inq_var_fill</code> function in the netCDF library C API.

# netcdf.inqVarFill

---

For copyright information, read the `netcdfcopyright.txt` and `mexnccopyright.txt` files.

## See Also

`netcdf` | `netcdf.defVarFill` | `netcdf.setFill`

<b>Purpose</b>	Fletcher32 checksum setting for NetCDF variable
<b>Syntax</b>	<code>setting = netcdf.inqVarFletcher32(ncid, varid)</code>
<b>Description</b>	<code>setting = netcdf.inqVarFletcher32(ncid, varid)</code> returns the Fletcher32 checksum setting for the NetCDF variable specified by <code>varid</code> in the file or group specified by <code>ncid</code> .
<b>Input Arguments</b>	<p><b>ncid</b> Identifier for NetCDF file, returned by <code>netcdf.create</code> or <code>netcdf.open</code>, or group, returned by <code>netcdf.defGrp</code>.</p> <p><b>varid</b> Identifier of NetCDF variable.</p>
<b>Output Arguments</b>	<p><b>setting</b> Text string specifying whether the Fletcher32 checksum is turned on for the specified variable. <code>netcdf.inqVarFletcher32</code> returns the text string <code>FLETCHER32</code> if the checksum is turned on for the variable; otherwise, <code>NOCHECKSUM</code>.</p>
<b>Examples</b>	<p>This example opens the sample NetCDF file and gets information about the checksum setting for a variable.</p> <pre>ncid = netcdf.open('example.nc', 'NOWRITE'); varid = netcdf.inqVarID(ncid, 'temperature'); setting = netcdf.inqVarFletcher32(ncid, varid); netcdf.close(ncid);</pre>
<b>References</b>	<p>This function corresponds to the <code>nc_inq_var_fletcher32</code> function in the netCDF library C API.</p> <p>For copyright information, read the <code>netcdfcopyright.txt</code> and <code>mexnccopyright.txt</code> for more information.</p>

# netcdf.inqVarFletcher32

---

## See Also

[netcdf](#) | [netcdf.defVarFletcher32](#)

<b>Purpose</b>	Return information about netCDF attribute
<b>Syntax</b>	<code>[xtype,attlen] = netcdf.inqAtt(ncid,varid,attname)</code>
<b>Description</b>	<p><code>[xtype,attlen] = netcdf.inqAtt(ncid,varid,attname)</code> returns the data type, <code>xtype</code>, and length, <code>attlen</code>, of the attribute identified by the text string <code>attname</code>.</p> <p><code>ncid</code> is a netCDF file identifier returned by <code>netcdf.create</code> or <code>netcdf.open</code>.</p> <p><code>varid</code> identifies the variable that the attribute is associated with. To get information about a global attribute, specify <code>netcdf.getConstant('NC_GLOBAL')</code> in place of <code>varid</code>.</p> <p>This function corresponds to the <code>nc_inq_att</code> function in the netCDF library C API. To use this function, you should be familiar with the netCDF programming paradigm. See <code>netcdf</code> for more information.</p>

## Examples

This example opens the example netCDF file included with MATLAB, `example.nc`, and gets information about an attribute in the file.

```
% Open netCDF example file.
ncid = netcdf.open('example.nc','NOWRITE');

% Get identifier of a variable in the file, given its name.
varid = netcdf.inqVarID(ncid,'avagadros_number');

% Get attribute name, given variable id and attribute number.
attname = netcdf.inqAttName(ncid,varid,0);

% Get information about the attribute.
[xtype,attlen] = netcdf.inqAtt(ncid,varid,'description')

xtype =
```

2

# netcdf.inqAtt

---

```
attlen =
 31

% Get name of global attribute
gattname = netcdf.inqAttName(ncid,netcdf.getConstant('NC_GLOBAL'),0);

% Get information about global attribute.
[gxtype gattlen] = netcdf.inqAtt(ncid,netcdf.getConstant('NC_GLOBAL'),gat

gxtype =
 2

gattlen =
 11
```

## See Also

[netcdf.inqAttID](#) | [netcdf.inqAttName](#)

## Purpose

Return ID of netCDF attribute

## Syntax

```
attnum = netcdf.inqAttID(ncid,varid,attname)
```

## Description

`attnum = netcdf.inqAttID(ncid,varid,attname)` retrieves `attnum`, the identifier of the attribute specified by the text string `attname`.

`varid` specifies the variable the attribute is associated with.

`ncid` is a netCDF file identifier returned by `netcdf.create` or `netcdf.open`.

This function corresponds to the `nc_inq_attid` function in the netCDF library C API. To use this function, you should be familiar with the netCDF programming paradigm. See `netcdf` for more information.

## Examples

This example opens the netCDF example file included with MATLAB, `example.nc`.

```
% Open the netCDF example file.
```

```
ncid = netcdf.open('example.nc','NC_NOWRITE');
```

```
% Get the identifier of a variable in the file.
```

```
varid = netcdf.inqVarID(ncid,'avagadros_number');
```

```
% Retrieve the identifier of the attribute associated with the variable.
```

```
attid = netcdf.inqAttID(ncid,varid,'description');
```

## See Also

`netcdf.inqAtt` | `netcdf.inqAttName`

# netcdf.inqAttName

---

**Purpose** Return name of netCDF attribute

**Syntax** `attname = netcdf.inqAttName(ncid,varid,attnum)`

**Description** `attname = netcdf.inqAttName(ncid,varid,attnum)` returns `attname`, a text string specifying the name of an attribute.

`ncid` is a netCDF file identifier returned by `netcdf.create` or `netcdf.open`.

`varid` is a numeric identifier of a variable in the file. If you want to get the name of a global attribute in the file, use `netcdf.getConstant('NC_GLOBAL')` in place of `attnum` is a zero-based numeric value specifying the attribute, with 0 indicating the first attribute, 1 the second attribute, and so on.

This function corresponds to the `nc_inq_attname` function in the netCDF library C API. To use this function, you should be familiar with the netCDF programming paradigm. See `netcdf` for more information.

**Examples** This example opens the example netCDF file included with MATLAB, `example.nc`.

```
% Open netCDF example file.
ncid = netcdf.open('example.nc','NC_NOWRITE');

% Get identifier of a variable in the file.
varid = netcdf.inqVarID(ncid,'avagadros_number')

% Get the name of the attribute associated with the variable.
attname = netcdf.inqAttName(ncid,varid,0)

attname =

description

% Get the name of the global attribute associated with the variable.
gattname = netcdf.inqAttName(ncid,netcdf.getConstant('NC_GLOBAL'),0)
```



gattname =

creation\_date

## See Also

[netcdf.inqAtt](#) | [netcdf.inqAttID](#)

# netcdf.inqDim

---

**Purpose** Return netCDF dimension name and length

**Syntax** [dimname, dimlen] = netcdf.inqDim(ncid,dimid)

**Description** [dimname, dimlen] = netcdf.inqDim(ncid,dimid) returns the name, dimname, and length, dimlen, of the dimension specified by dimid. If ndims is the number of dimensions defined for a netCDF file, each dimension has an ID between 0 and ndims-1. For example, the dimension identifier of the first dimension is 0, the second dimension is 1, and so on.

ncid is a netCDF file identifier returned by netcdf.create or netcdf.open.

This function corresponds to the nc\_inq\_dim function in the netCDF library C API. To use this function, you should be familiar with the netCDF programming paradigm. See netcdf for more information.

**Examples** The example opens the example netCDF file include with MATLAB, example.nc.

```
ncid = netcdf.open('example.nc','NC_NOWRITE');
```

```
% Get name and length of first dimension
[dimname, dimlen] = netcdf.inqDim(ncid,0)
```

```
dimname =
```

```
x
```

```
dimlen =
```

```
50
```

**See Also** netcdf.inqDimID

**Purpose** Return dimension ID

**Syntax** `dimid = netcdf.inqDimID(ncid,dimname)`

**Description** `dimid = netcdf.inqDimID(ncid,dimname)` returns `dimid`, the identifier of the dimension specified by the character string `dimname`. You can use the `netcdf.inqDim` function to retrieve the dimension name. `ncid` is a netCDF file identifier returned by `netcdf.create` or `netcdf.open`.

This function corresponds to the `nc_inq_dimid` function in the netCDF library C API. To use this function, you should be familiar with the netCDF programming paradigm. See `netcdf` for more information.

**Examples** This example opens the example netCDF file included with MATLAB, `example.nc`.

```
% Open netCDF example file.
ncid = netcdf.open('example.nc','NC_NOWRITE');

% Get name and length of first dimension
[dimname, dimlen] = netcdf.inqDim(ncid,0);

% Retrieve identifier of dimension.
dimid = netcdf.inqDimID(ncid,dimname)

dimid =

 0
```

**See Also** `netcdf.inqDim`

# netcdf.inqLibVers

---

**Purpose** Return NetCDF library version information

**Syntax** `libvers = netcdf.inqLibVers`

**Description** `libvers = netcdf.inqLibVers` returns a string identifying the version of the NetCDF library.

This function corresponds to the `nc_inq_libvers` function in the NetCDF library C API. To use this function, you should be familiar with the netCDF programming paradigm. See `netcdf` for more information.

**Examples** `libvers = netcdf.inqLibVers`

```
libvers =
```

```
4.1.3
```

<b>Purpose</b>	Information about variable
<b>Syntax</b>	<code>[varname,xtype,dimids,natts] = netcdf.inqVar(ncid,varid)</code>
<b>Description</b>	<p><code>[varname,xtype,dimids,natts] = netcdf.inqVar(ncid,varid)</code> returns information about the variable identified by <code>varid</code>. The argument, <code>ncid</code>, is a netCDF file identifier returned by <code>netcdf.create</code> or <code>netcdf.open</code>.</p> <p>The output argument, <code>varname</code>, is the name of the variable. <code>xtype</code> is the data type, <code>dimids</code> is the dimension IDs, and <code>natts</code> is the number of attributes associated with the variable. Dimension IDs are zero-based.</p> <p>This function corresponds to the <code>nc_inq_var</code> function in the netCDF library C API. Because MATLAB uses FORTRAN-style ordering, however, the order of the dimension IDs is reversed relative to what would be obtained from the C API. To use this function, you should be familiar with the netCDF programming paradigm. See <code>netcdf</code> for more information.</p>

**Examples** Open the example netCDF file included with MATLAB, `example.nc`, and get information about a variable in the file.

```
% Open the example netCDF file.
ncid = netcdf.open('example.nc','NC_NOWRITE');

% Get information about third variable in the file.
[varname, xtype, dimids, numatts] = netcdf.inqVar(ncid,2)

varname =

peaks

xtype =
```

5

# netcdf.inqVar

---

```
dimids =
```

```
 0 1
```

```
numatts =
```

```
 1 1
```

## See Also

[netcdf.create](#) | [netcdf.inqVarID](#) | [netcdf.open](#)

**Purpose** Return ID associated with variable name

**Syntax** `varid = netcdf.inqVarID(ncid,varname)`

**Description** `varid = netcdf.inqVarID(ncid,varname)` returns `varid`, the ID of a netCDF variable specified by the text string, `varname`.

`ncid` is a netCDF file identifier returned by `netcdf.create` or `netcdf.open`.

This function corresponds to the `nc_inq_varid` function in the netCDF library C API. To use this function, you should be familiar with the netCDF programming paradigm. See `netcdf` for more information.

**Examples** This example opens the example netCDF file included with MATLAB, `example.nc`, and uses several inquiry functions to get the ID of the first variable.

```
ncid = netcdf.open('example.nc','NC_NOWRITE');

% Get information about first variable in the file.
[varname, xtype, dimids, atts] = netcdf.inqVar(ncid,0);

% Get variable ID of the first variable, given its name
varid = netcdf.inqVarID(ncid,varname)

varid =

 0
```

**See Also** `netcdf.create` | `netcdf.inqVar` | `netcdf.open`

# netcdf.open

---

**Purpose** Open NetCDF data source

**Syntax**

```
ncid = netcdf.open(source)
ncid = netcdf.open(source,mode)
[chosen_chunksize, ncid] = netcdf.open(source,mode,chunksize)
```

**Description** `ncid = netcdf.open(source)` opens `source`, which can be the name of a NetCDF file or the URL of an OPeNDAP NetCDF data source, for read-only access. Returns a NetCDF ID in `ncid`.

`ncid = netcdf.open(source,mode)` opens `source` with the type of access specified by `mode`, which can have any of the following values.

Value	Description
'WRITE'	Read-write access
'SHARE'	Synchronous file updates
'NOWRITE'	Read-only access (Default)

You can also specify `mode` as a numeric value that can be retrieved using `netcdf.getConstant`. Use these numeric values when you want to specify a bitwise-OR of several modes.

```
[chosen_chunksize, ncid] =
netcdf.open(source,mode,chunksize)
```

opens `source`, an existing netCDF data source, specifying the additional I/O performance tuning parameter, `chunksize`. The actual value used by the NetCDF library might not correspond to the input value you specify.

This function corresponds to the `nc_open` and `nc__open` functions in the netCDF library C API. To use this function, you should be familiar with the netCDF programming paradigm. See `netcdf` for more information.

**Examples** This example opens the example NetCDF file included with MATLAB, `example.nc`.

```
ncid = netcdf.open('example.nc','NOWRITE');
netcdf.close(ncid);
```



## See Also

[netcdf.close](#) | [netcdf](#) | [netcdf.getConstant](#)

# netcdf.putAtt

---

**Purpose** Write netCDF attribute

**Syntax** `netcdf.putAtt(ncid,varid,attrname,attrvalue)`

**Description** `netcdf.putAtt(ncid,varid,attrname,attrvalue)` writes the attribute named `attrname` with value `attrvalue` to the netCDF variable specified by `varid`. To specify a global attribute, use `netcdf.getConstant('NC_GLOBAL')` for `varid`.

`ncid` is a netCDF file identifier returned by `netCDF.create` or `netCDF.open`.

---

**Note** You cannot use `netcdf.putAtt` to set the `'_FillValue'` attribute of NetCDF4 files. Use the `netcdf.defVarFill` function to set the fill value for a variable.

---

This function corresponds to several attribute I/O functions in the netCDF library C API. To use this function, you should be familiar with the netCDF programming paradigm. See `netcdf` for more information.

## Examples

This example creates a new netCDF file, defines a dimension and a variable, adds data to the variable, and then creates an attribute associated with the variable. To run this example, you must have writer permission in your current directory.

```
% Create a variable in the workspace.
my_vardata = linspace(0,50,50);

% Create a netCDF file.
ncid = netcdf.create('foo.nc','NC_WRITE');

% Define a dimension in the file.
dimid = netcdf.defDim(ncid,'my_dim',50);

% Define a new variable in the file.
```

```
varid = netcdf.defVar(ncid,'my_var','double',dimid);

% Leave define mode and enter data mode to write data.
netcdf.endDef(ncid);

% Write data to variable.
netcdf.putVar(ncid,varid,my_vardata);

% Re-enter define mode.
netcdf.reDef(ncid);

% Create an attribute associated with the variable.
netcdf.putAtt(ncid,0,'my_att',10);

% Verify that the attribute was created.
[xtype xlen] = netcdf.inqAtt(ncid,0,'my_att')

xtype =

 6

xlen =

 1
```

---

This example creates a new netCDF file, specifies a global attribute, and assigns a value to the attribute.

```
ncid = netcdf.create('myfile.nc','CLOBBER');
varid = netcdf.getConstant('GLOBAL');
netcdf.putAtt(ncid,varid,'creation_date',datestr(now));
netcdf.close(ncid);
```

## See Also

[netcdf.getAtt](#) | [netcdf.defVarFill](#) | [netcdf.getConstant](#)

# netcdf.putVar

---

**Purpose** Write data to netCDF variable

**Syntax**

```
netcdf.putVar(ncid,varid,data)
netcdf.putVar(ncid,varid,start,data)
netcdf.putVar(ncid,varid,start,count,data)
netcdf.putVar(ncid,varid,start,count,stride,data)
```

**Description** `netcdf.putVar(ncid,varid,data)` writes data to a netCDF variable identified by `varid`.

`ncid` is a netCDF file identifier returned by `netcdf.create` or `netcdf.open`.

`netcdf.putVar(ncid,varid,start,data)` writes a single data value into the variable at the index specified by `start`.

`netcdf.putVar(ncid,varid,start,count,data)` writes a section of values into the netCDF variable at the index specified by the vector `start` to the extent specified by the vector `count`, along each dimension of the specified variable.

`netcdf.putVar(ncid,varid,start,count,stride,data)` writes the subsection specified by sampling interval, `stride`, of the values in the section of the variable beginning at the index `start` and to the extent specified by `count`.

This function corresponds to several variable I/O functions in the netCDF library C API. To use this function, you should be familiar with the netCDF programming paradigm. See `netcdf` for more information.

## **Examples**      **Write Variable to New netCDF File**

Create a new netCDF file and write a variable to the file.

Create a 50 element vector for a variable.

```
my_vardata = linspace(0,50,50);
```

Open the netCDF file.

```
ncid = netcdf.create('foo.nc', 'NOCLOBBER');
```

Define the dimensions of the variable.

```
dimid = netcdf.defDim(ncid, 'my_dim', 50);
```

Define a new variable in the file.

```
my_varID = netcdf.defVar(ncid, 'my_var', 'double', dimid);
```

Leave define mode and enter data mode to write data.

```
netcdf.endDef(ncid);
```

Write data to variable.

```
netcdf.putVar(ncid, my_varID, my_vardata);
```

Verify that the variable was created.

```
[varname xtype dimid natts] = netcdf.inqVar(ncid, 0)
```

```
varname =
```

```
my_var
```

```
xtype =
```

```
6
```

```
dimid =
```

```
0
```

```
natts =
```

# netcdf.putVar

---

0

Close the file.

```
netcdf.close(ncid)
```

## Write Elements of Variable

Write to the first ten elements of the example temperature variable.

```
srcFile = fullfile(matlabroot,'toolbox','matlab','demos','example.nc');
copyfile(srcFile,'myfile.nc');
fileattrib('myfile.nc','+w');
ncid = netcdf.open('myfile.nc','WRITE');
varid = netcdf.inqVarID(ncid,'temperature');
data = [100:109];
netcdf.putVar(ncid,varid,0,10,data);
netcdf.close(ncid);
```

## See Also

```
netcdf.getVar
```

<b>Purpose</b>	Put open netCDF file into define mode
<b>Syntax</b>	<code>netcdf.reDef(ncid)</code>
<b>Description</b>	<p><code>netcdf.reDef(ncid)</code> puts an open netCDF file into define mode so that dimensions, variables, and attributes can be added or renamed. Attributes can also be deleted in define mode. <code>ncid</code> is a valid NetCDF file ID, returned from a previous call to <code>netcdf.open</code> or <code>netcdf.create</code>.</p> <p>This function corresponds to the <code>nc_redef</code> function in the netCDF library C API. To use this function, you should be familiar with the netCDF programming paradigm. See <code>netcdf</code> for more information.</p>
<b>Examples</b>	<p>This example opens a local copy of the example netCDF file included with MATLAB, <code>example.nc</code>.</p> <pre>% Open a netCDF file. ncid = netcdf.open('my_example.nc','NC_WRITE')  % Try to define a dimension. dimid = netcdf.defdim(ncid, 'lat', 50); % should fail. ??? Error using ==&gt; netcdflib NetCDF: Operation not allowed in data mode  Error in ==&gt; defDim at 22 dimid = netcdflib('def_dim', ncid,dimname,dimlen);  % Put file in define mode. netcdf.reDef(ncid);  % Try to define a dimension again. Should succeed. dimid = netcdf.defDim(ncid, 'lat', 50);</pre>
<b>See Also</b>	<code>netcdf.create</code>   <code>netcdf.endDef</code>   <code>netcdf.open</code>

# netcdf.renameAtt

---

**Purpose** Change name of attribute

**Syntax** `netcdf.renameAtt(ncid,varid,oldName,newName)`

**Description** `netcdf.renameAtt(ncid,varid,oldName,newName)` changes the name of the attribute specified by the character string `oldName`.

`newName` is a character string that specifies the new name.

`ncid` is a netCDF file identifier returned by `netcdf.create` or `netcdf.open`.

`varid` identifies the variable to which the attribute is associated. To specify a global attribute, use `netcdf.getConstant('NC_GLOBAL')` for `varid`.

This function corresponds to the `nc_rename_att` function in the netCDF library C API. To use this function, you should be familiar with the netCDF programming paradigm. See `netcdf` for more information.

**Examples** This example modifies a local copy of the example netCDF file included with MATLAB, `example.nc`.

```
% Open netCDF file.
ncid = netcdf.open('my_example.nc','NC_WRITE')

% Get the ID of a variable the attribute is associated with.
varID = netcdf.inqVarID(ncid,'avagadros_number')

% Rename the attribute.
netcdf.renameAtt(ncid,varID,'description','Description');

% Verify that the name changed.
attname = netcdf.inqAttName(ncid,varID,0)

attname =

Description
```



**See Also**      `netcdf.inqAttName`

# netcdf.renameDim

---

**Purpose** Change name of netCDF dimension

**Syntax** `netcdf.renameDim(ncid,dimid,newName)`

**Description** `netcdf.renameDim(ncid,dimid,newName)` renames the dimension identified by the dimension identifier, `dimid`.

`newName` is a character string specifying the new name. `ncid` is a netCDF file identifier returned by `netcdf.create` or `netcdf.open`

This function corresponds to the `nc_rename_dim` function in the netCDF library C API. To use this function, you should be familiar with the netCDF programming paradigm. See `netcdf` for more information.

**Examples** This examples modifies a local copy of the example netCDF file included with MATLAB, `example.nc`.

```
% Open netCDF file.
ncid = netcdf.open('my_example.nc','NC_WRITE')

% Put file is define mode.
netcdf.reDef(ncid)

% Get the identifier of a dimension to rename.
dimid = netcdf.inqDimID(ncid,'x');

% Rename the dimension.
netcdf.renameDim(ncid,dimid,'Xdim')

% Verify that the name changed.
data = netcdf.inqDim(ncid,dimid)

data =

Xdim
```

**See Also** `netcdf.defDim`

**Purpose** Change name of netCDF variable

**Syntax** `netcdf.renameVar(ncid,varid,newName)`

**Description** `netcdf.renameVar(ncid,varid,newName)` renames the variable identified by `varid` in the netCDF file identified by `ncid`. `newName` is a character string specifying the new name.

This function corresponds to the `nc_rename_var` function in the netCDF library C API. To use this function, you should be familiar with the netCDF programming paradigm. See `netcdf` for more information.

**Examples** This example modifies a local copy of the example netCDF file included with MATLAB, `example.nc`.

```
% Open netCDF file.
ncid = netcdf.open('my_example.nc','NC_WRITE')

% Put file in define mode.
netcdf.redef(ncid)

% Get name of first variable
[varname, xtype, varDimIDs, varAtts] = netcdf.inqVar(ncid,0);

varname

varname =

avagadros_number

% Rename the variable, using a capital letter to start the name.
netcdf.renameVar(ncid,0,'Avagadros_number')

% Verify that the name of the variable changed.
[varname, xtype, varDimIDs, varAtts] = netcdf.inqVar(ncid,0);

varname
```

# netcdf.renameVar

---

varname =

Avagadros\_number

## See Also

[netCDF.defVar](#) | [netCDF.inqVar](#) | [netCDF.putVar](#)

<b>Purpose</b>	Set default chunk cache settings for NetCDF library
<b>Syntax</b>	<code>netcdf.setChunkCache(csize, nelems, premp)</code>
<b>Description</b>	<p><code>netcdf.setChunkCache(csize, nelems, premp)</code> sets the default chunk cache settings used by the NetCDF library.</p> <p>Settings apply for subsequent file open or create operations, for the remainder of the MATLAB session or until you issue a <code>clear mex</code> call. This function does not change the chunk cache settings of files already open.</p>
<b>Input Arguments</b>	<p><b>csize</b></p> <p>Scalar double specifying the total size of the raw data chunk cache in bytes.</p> <p><b>nelems</b></p> <p>Scalar double specifying the number of chunk slots in the raw data chunk cache hash table.</p> <p><b>premp</b></p> <p>Scalar double, between 0 and 1, inclusive, that specifies how the library handles preempting fully read chunks in the chunk cache. A value of 0 means fully read chunks are treated no differently than other chunks, that is, preemption occurs solely based on the Least Recently Used (LRU) algorithm. A value of 1 means fully read chunks are always preempted before other chunks.</p>
<b>Examples</b>	<p>This example sets the cache chunk size used by the NetCDF library.</p> <pre>netcdf.setChunkCache(32000000, 2003, .75)</pre>
<b>References</b>	This function corresponds to the <code>nc_set_chunk_cache</code> function in the NetCDF library C API.

# netcdf.setChunkCache

---

For copyright information, read the `netcdfcopyright.txt` and `mexnccopyright.txt` files.

## **See Also**

`netcdf` | `netcdf.getChunkCache`

**Purpose** Change default netCDF file format

**Syntax** `oldFormat = netcdf.setDefaultFormat(newFormat)`

**Description** `oldFormat = netcdf.setDefaultFormat(newFormat)` changes the default format used by `netCDF.create` when creating new netCDF files, and returns the value of the old format. You can use this function to change the format used by a netCDF file without having to change the creation mode flag used in each call to `netCDF.create`.

`newFormat` can be either of the following values.

Value	Description
'NC_FORMAT_CLASSIC'	Original netCDF file format
'NC_FORMAT_64BIT'	64-bit offset format; relaxes limitations on creating very large files

You can also specify the numeric equivalent of these values, as retrieved by `netcdf.getConstant`.

This function corresponds to the `nc_set_default_format` function in the netCDF library C API. To use this function, you should be familiar with the netCDF programming paradigm. See `netcdf` for more information.

**Examples** `oldFormat = netcdf.setDefaultFormat('NC_FORMAT_64BIT');`

**See Also** `netcdf.create`

# netcdf.setFill

---

**Purpose** Set netCDF fill mode

**Syntax** `old_mode = netcdf.setFill(ncid,new_mode)`

**Description** `old_mode = netcdf.setFill(ncid,new_mode)` sets the fill mode for a netCDF file identified by `ncid`.

`new_mode` can be either 'FILL' or 'NOFILL' or their numeric equivalents, as retrieved by `netcdf.getConstant`. The default mode is 'FILL'. netCDF pre-fills data with fill values. Specifying 'NOFILL' can be used to enhance performance, because it avoids the duplicate writes that occur when the netCDF writes fill values that are later overwritten with data.

This function corresponds to the `nc_set_fill` function in the netCDF library C API. To use this function, you should be familiar with the netCDF programming paradigm. See `netcdf` for more information.

**Examples** This example creates a new file and specifies the fill mode used by netCDF with the file.

```
ncid = netcdf.open('foo.nc','NC_WRITE');

% Set filling behavior
old_mode = netcdf.setFill(ncid,'NC_NOFILL');
```

**See Also** `netcdf.getConstant`



**Purpose** Synchronize netCDF file to disk

**Syntax** `netcdf.sync(ncid)`

**Description** `netcdf.sync(ncid)` synchronizes the state of a netCDF file to disk. The netCDF library normally buffers accesses to the underlying netCDF file, unless you specify the `NC_SHARE` mode when you opened the file with `netcdf.open` or `netcdf.create`. To call `netcdf.sync`, the netCDF file must be in data mode.

This function corresponds to the `nc_sync` function in the netCDF library C API. To use this function, you should be familiar with the netCDF programming paradigm. See `netcdf` for more information.

**Examples** This example creates a new netCDF file for write access, performs an operation on the file, takes the file out of define mode, and then synchronizes the file to disk.

```
% Create a netCDF file.
ncid = netcdf.create('foo.nc','NC_WRITE');

% Perform an operation.
dimid = netcdf.defDim(ncid,'Xdim',50);

% Take file out of define mode.
netcdf.endDef(ncid);

% Synchronize the file to disk.
netcdf.sync(ncid)
```

**See Also** `netcdf.close` | `netcdf.create` | `netcdf.open` | `netcdf.endDef`

# newplot

---

**Purpose** Determine where to draw graphics objects

**Syntax**

```
newplot
h = newplot
h = newplot(hsave)
```

**Description** `newplot` prepares a figure and axes for subsequent graphics commands.

`h = newplot` prepares a figure and axes for subsequent graphics commands and returns a handle to the current axes.

`h = newplot(hsave)` prepares and returns an axes, but does not delete any objects whose handles you have assigned to the `hsave` argument, which can be a vector of handles. If `hsave` is not empty, the figure and axes containing `hsave` are prepared for plotting instead of the current axes of the current figure. If `hsave` is empty, `newplot` behaves as if it were called without any inputs.

**Tips** To create a simple 2-D plot, use the `plot` function instead.

Use `newplot` at the beginning of high-level graphics code to determine which figure and axes to target for graphics output. Calling `newplot` can change the current figure and current axes. Basically, there are three options when you are drawing graphics in existing figures and axes:

- Add the new graphics without changing any properties or deleting any objects.
- Delete all existing objects whose handles are not hidden before drawing the new objects.
- Delete all existing objects regardless of whether or not their handles are hidden, and reset most properties to their defaults before drawing the new objects (refer to the following table for specific information).

The figure and axes `NextPlot` properties determine how `newplot` behaves. The following two tables describe this behavior with various property values.

First, `newplot` reads the current figure's `NextPlot` property and acts accordingly.

NextPlot	What Happens
new	Create a new figure and use it as the current figure.
add	Draw to the current figure without clearing any graphics objects already present.
replacechildren	<p>Remove all child objects whose HandleVisibility property is set to on and reset figure NextPlot property to add.</p> <p>This clears the current figure and is equivalent to issuing the clf command.</p>
replace	<p>Remove all child objects (regardless of the setting of the HandleVisibility property) and reset figure properties to their defaults, except NextPlot is reset to add regardless of user-defined defaults.</p> <ul style="list-style-type: none"> <li>• Position, Units, PaperPosition, and PaperUnits are not reset.</li> </ul> <p>This clears and resets the current figure and is equivalent to issuing the clf reset command.</p>

After newplot establishes which figure to draw in, it reads the current axes' NextPlot property and acts accordingly.

NextPlot	Description
add	Draw into the current axes, retaining all graphics objects already present.
replacechildren	Remove all child objects whose HandleVisibility property is set to on, but do not reset axes properties. This clears the current axes like the cla command.
replace	Remove all child objects (regardless of the setting of the HandleVisibility property) and reset axes properties to their defaults, except Position and Units.  This clears and resets the current axes like the cla reset command.

## See Also

plot | axes | cla | clf | figure | hold | ishold | reset | figure | axes

## How To

- Controlling Graphics Output

**Purpose** Make next IFD current IFD

**Syntax** `tiffobj.nextDirectory()`

**Description** `tiffobj.nextDirectory()` makes the next image file directory (IFD) in the file the current IFD. `Tiff` object methods operate on the current IFD. Use this method to navigate among IFDs in a TIFF file containing multiple images.

**Examples**      **Make Next Directory the Current Directory**

Open a `Tiff` object and change the current IFD to the next IFD in the file.

```
t = Tiff('example.tif', 'r');
t.nextDirectory();
t.close();
```

**References** This method corresponds to the `TIFFReadDirectory` function in the LibTIFF C API. To use this method, you must be familiar with the TIFF specification and technical notes. View this documentation at [LibTIFF - TIFF Library and Utilities](#).

**See Also** `Tiff.setDirectory`

**Tutorials**

- “Exporting Image Data and Metadata to TIFF Files”
- “Reading Image Data and Metadata from TIFF Files”

# nextpow2

---

**Purpose** Exponent of next higher power of 2

**Syntax** `P = nextpow2(A)`

**Description** `P = nextpow2(A)` returns the exponents for the smallest powers of two that satisfy

$$2^p \geq |A|$$

for each element in A.

You can use `nextpow2` to pad the signal you pass to `fft`. Doing so can speed up the computation of the FFT when the signal length is not an exact power of 2.

## Input Arguments

### A - Input values

scalar, vector, or array of real numbers

Input values, specified as a scalar, vector, or array of real numbers of any numeric type.

**Example:** 15

**Example:** `[-15.123 32.456 63.111]`

**Example:** `int16([-15 32 63])`

### Data Types

`single` | `double` | `int8` | `int16` | `int32` | `int64` | `uint8` | `uint16` | `uint32` | `uint64`

## Examples

### Next Power of 2 of Double Integer Values

Define a vector of double integer values and calculate the exponents for the next power of 2 higher than those values.

```
a = [1 -2 3 -4 5 9 519];
p = nextpow2(a)
```

```
p =
```

```

0 1 2 2 3 4 10

```

Calculate the positive next powers of 2.

```
np2 = 2.^p
```

```
np2 =
```

```

1 2 4 4 8 16 1024

```

Preserve the sign of the original input values.

```
np2.*sign(a)
```

```
ans =
```

```

1 -2 4 -4 8 16 1024

```

### Next Power of 2 of Unsigned Integer Values

Define a vector of unsigned integers and calculate the exponents for the next power of 2 higher than those values.

```
a = uint32([1020 4000 32700]);
p = nextpow2(a)
```

```
p =
```

```

10 12 15

```

Calculate the next powers of 2 higher than the values in a.

```
2.^p
```

```
ans =
```

```

1024 4096 32768

```

## Optimize FFT with Padding

Use `nextpow2` to increase the performance of `fft` when the length of your signal is not a power of 2.

Create a 1-D vector containing 8191 sample values.

```
x = gallery('uniformdata',[1,8191],0);
```

Calculate the next power of 2 higher than 8191.

```
p = nextpow2(8191);
```

```
n = 2^p
```

```
n =
```

```
8192
```

Pass the signal and the next power of 2 to the `fft` function.

```
y = fft(x,n);
```

## See Also

[fft](#) | [log2](#) | [pow2](#)



---

<b>Purpose</b>	Number of nonzero matrix elements
<b>Syntax</b>	<code>n = nnz(X)</code>
<b>Description</b>	<code>n = nnz(X)</code> returns the number of nonzero elements in matrix <code>X</code> . The density of a sparse matrix is <code>nnz(X)/prod(size(X))</code> .
<b>Examples</b>	The matrix  <code>w = sparse(wilkinson(21));</code>  is a tridiagonal matrix with 20 nonzeros on each of three diagonals, so <code>nnz(w) = 60</code> .
<b>See Also</b>	<code>find</code>   <code>isa</code>   <code>nonzeros</code>   <code>nzmax</code>   <code>size</code>   <code>whos</code>

# noanimate

---

**Purpose** Change EraseMode of all objects to normal

---

**Note** noanimate will be removed in a future release.

---

**Syntax** noanimate(state, fig\_handle)  
noanimate(state)

**Description** noanimate(state, fig\_handle) sets the EraseMode of all image, line, patch, surface, and text graphics objects in the specified figure to normal. state can be the following strings:

- 'save' — Set the values of the EraseMode properties to normal for all the appropriate objects in the designated figure.
- 'restore' — Restore the EraseMode properties to the previous values (i.e., the values before calling noanimate with the 'save' argument).

noanimate(state) operates on the current figure.

noanimate is useful if you want to print the figure to a TIFF or JPEG format.

**See Also** print

**Purpose** Nonzero matrix elements

**Syntax** `s = nonzeros(A)`

**Description** `s = nonzeros(A)` returns a full column vector of the nonzero elements in A, ordered by columns.

This gives the s, but not the i and j, from `[i,j,s] = find(A)`.  
Generally,

`length(s) = nnz(A) <= nzmax(A) <= prod(size(A))`

**See Also** `find` | `isa` | `nnz` | `nzmax` | `size` | `whos`

# norm

---

**Purpose** Vector and matrix norms

**Syntax**  
`n = norm(X)`  
`n = norm(X,p)`

**Description** `n = norm(X)` returns the 2-norm of input  $X$  and is equivalent to `norm(X,2)`. If  $X$  is a vector, this is equal to the Euclidean distance. If  $X$  is a matrix, this is equal to the largest singular value of  $X$ .

`n = norm(X,p)` returns the  $p$ -norm of input  $X$ .

**Input Arguments**  
**X - Numeric array**  
scalar | vector | matrix

Numeric array, specified as a scalar, vector, or matrix. If  $X$  is sparse, then `norm(X)` returns an error.

**Data Types**

single | double

**Complex Number Support:** Yes

**p - Norm type**

2 (default) | positive integer scalar | Inf | -Inf | 'fro'

Norm type, specified as 2 (default), a positive integer scalar, Inf, -Inf, or 'fro'. Whether  $X$  is a matrix or vector determines the allowed values of  $p$  (and what they return). The following table lists the calculated values for each allowed value of  $p$ .

---

**Note** The table does not reflect the actual algorithms used in calculations.

---

<b>p</b>	<b>Matrix</b>	<b>Vector</b>
1	$\max(\text{sum}(\text{abs}(X)))$	$\text{sum}(\text{abs}(X))$
2	$\max(\text{svd}(X))$	$\text{sum}(\text{abs}(X).^2)^{(1/2)}$
positive, real-valued numeric p	–	$\text{sum}(\text{abs}(X).^p)^{(1/p)}$
Inf	$\max(\text{sum}(\text{abs}(X')))$	$\max(\text{abs}(X))$
-Inf	–	$\min(\text{abs}(X))$
'fro'	$\text{sqrt}(\text{sum}(\text{diag}(X'*X)))$	$\text{norm}(X)$

## Output Arguments

### **n** - Matrix or vector norm

scalar

Matrix or vector norm, returned as a scalar. The norm gives a measure of the magnitude of the elements. By convention, norm returns NaN if the input contains NaN values.

## Examples

### **1- and 2- Norm of Vector**

Create a vector corresponding to the point (-2,3,-1) in 3-D space.

```
X = [-2 3 -1];
```

Calculate the 2-norm of the vector.

```
n = norm(X)
```

```
n =
```

```
3.7417
```

The 2-norm is equal to the Euclidean length of the vector.

Calculate the 1-norm of the vector.

```
n = norm(X,1)
```

```
n =
```

```
6
```

The 1-norm is equal to the sum of the element magnitudes.

## **2-Norm of Matrix**

Create a matrix.

```
X = [2 0 1; -1 1 0; -3 3 0];
```

The matrix has  $\text{rank}(X) = 2$ , so it has two nonzero singular values.

Calculate the 2-norm of the matrix.

```
n = norm(X)
```

```
n =
```

```
4.7234
```

The 2-norm is equal to the largest singular value of X.

## **Frobenius Norm of Sparse Matrix**

Create a sparse identity matrix, S.

```
S = sparse(1:25,1:25,1);
```

Attempt to use `norm(S)` to calculate the 2-norm of S.

```
n = norm(S)
```

```
Error using norm
```

```
Sparse norm(S,2) is not available.
```

When the input matrix is sparse, `norm(S)` returns an error.

Now use 'fro' to calculate the Frobenius norm of the sparse matrix.

```
n = norm(S, 'fro')
```

```
n =
```

```
5
```

This calculates the 2-norm of the column vector,  $S(:)$ .

**See Also**

[cond](#) | [rcond](#) | [condest](#) | [normest](#) | [hypot](#)

# normest

---

**Purpose** 2-norm estimate

**Syntax**  
`nrm = normest(S)`  
`nrm = normest(S,tol)`  
`[nrm,count] = normest(...)`

**Description** This function is intended primarily for sparse matrices, although it works correctly and may be useful for large, full matrices as well.

`nrm = normest(S)` returns an estimate of the 2-norm of the matrix  $S$ .

`nrm = normest(S,tol)` uses relative error `tol` instead of the default tolerance  $1.e-6$ . The value of `tol` determines when the estimate is considered acceptable.

`[nrm,count] = normest(...)` returns an estimate of the 2-norm and also gives the number of power iterations used.

**Algorithms** The power iteration involves repeated multiplication by the matrix  $S$  and its transpose,  $S'$ . The iteration is carried out until two successive estimates agree to within the specified relative tolerance.

**See Also** `cond` | `condest` | `norm` | `rcond` | `svd`



**Purpose** Find logical NOT

**Syntax** ~A  
not(A)

**Description** ~A performs a logical NOT of input array A, and returns an array containing elements set to either logical 1 (true) or logical 0 (false). An element of the output array is set to 1 if the input array contains a zero value element at that same array location. Otherwise, that element is set to 0.

The input of the expression can be an array or can be a scalar value. If the input is an array, then the output is an array of the same dimensions. If the input is scalar, then the output is scalar.

not(A) is called for the syntax ~A when A is an object.

**Examples** If matrix A is

0	29	0	36	0
23	34	35	0	39
0	24	31	27	0
0	29	0	0	34

then

```
~A
ans =
 1 0 1 0 1
 0 0 0 1 0
 1 0 0 0 1
 1 0 1 1 0
```

**See Also** any | all | bitcmp | xor | and | or

**Concepts** • “Truth Table for Logical Operations”

# notebook

---

**Purpose** Open MATLAB Notebook in Microsoft Word software (on Microsoft Windows platforms)

**Syntax** `notebook`  
`notebook('filename')`  
`notebook('-setup')`

**Description** `notebook` starts Microsoft Word software and creates a new MATLAB Notebook titled Document 1.

`notebook('filename')` starts Microsoft Word and opens the notebook `filename`, where `filename` is either in the MATLAB current folder or is a full path. If `filename` does not exist, MATLAB creates a new notebook titled `filename`. If the file name extension is not specified, MATLAB assumes `.doc`.

`notebook('-setup')` runs an interactive setup function for MATLAB Notebook. It copies the notebook template, `m-book.dot`, to the Microsoft Word template folder, whose location MATLAB automatically determines from the Windows system registry. Upon completion, MATLAB displays a message indicating whether or not the setup was successful.

**How To**

- “Create a MATLAB Notebook with Microsoft Word”
- “Publishing MATLAB Code”

**Purpose** Notify listeners that event is occurring

**Syntax** `notify(Hobj, 'EventName')`  
`notify(Hobj, 'EventName', data)`

**Description** `notify(Hobj, 'EventName')` notifies listeners that the specified event is taking place on the specified handle objects.

`notify(Hobj, 'EventName', data)` includes user-defined event data.

### **Input Arguments**

**Hobj**

Array of handle objects triggering the specified event.

**EventName**

Name of the event.

**data**

An `event.EventData` object encapsulating information about the event. You can define custom event data by subclassing `event.EventData` and passing an instance of your subclass as the data argument. See “Defining Event-Specific Data” for information on defining event data.

### **See Also**

See “Events and Listeners — Syntax and Techniques”

`handle`, `addlistener`

# now

---

**Purpose** Current date and time as serial date number

**Syntax** `t = now`

**Description** `t = now` returns the current date and time as a serial date number. A serial date number represents the whole and fractional number of days from a fixed, preset date (January 0, 0000).

`floor(now)` returns the current date as a serial date number, and `rem(now,1)` returns the current time as a serial date number. `datestr(now)` returns the current date and time as a string.

**Examples** `t1 = now, t2 = rem(now,1)`

```
t1 =

 7.2908e+05
```

```
t2 =

 0.4013
```

**See Also** `clock` | `date` | `datenum` | `datestr`

---

<b>Purpose</b>	Real nth root of real numbers
<b>Syntax</b>	$y = \text{nthroot}(X, n)$
<b>Description</b>	$y = \text{nthroot}(X, n)$ returns the real nth root of the elements of $X$ . Both $X$ and $n$ must be real and $n$ must be a scalar. If $X$ has negative entries, $n$ must be an odd integer.
<b>Examples</b>	$\text{nthroot}(-2, 3)$  returns the real cube root of -2.  $\text{ans} =$  -1.2599  By comparison,  $(-2)^{(1/3)}$  returns a complex cube root of -2.  $\text{ans} =$  $0.6300 + 1.0911i$
<b>See Also</b>	<a href="#">sqrt</a>   <a href="#">power</a>

# null

---

**Purpose** Null space

**Syntax** `Z = null(A)`  
`Z = null(A, 'r')`

**Description** `Z = null(A)` is an orthonormal basis for the null space of  $A$  obtained from the singular value decomposition. That is,  $A*Z$  has negligible elements, `size(Z,2)` is the nullity of  $A$ , and  $Z'*Z = I$ .

`Z = null(A, 'r')` is a “rational” basis for the null space obtained from the reduced row echelon form.  $A*Z$  is zero, `size(Z,2)` is an estimate for the nullity of  $A$ , and, if  $A$  is a small matrix with integer elements, the elements of the reduced row echelon form (as computed using `rref`) are ratios of small integers.

The orthonormal basis is preferable numerically, while the rational basis may be preferable pedagogically.

## Examples **Example 1**

Compute the orthonormal basis for the null space of a matrix  $A$ .

```
A = [1 2 3
 1 2 3
 1 2 3];
```

```
Z = null(A);
A*Z
```

```
ans =
 1.0e-015 *
 0.2220 0.2220
 0.2220 0.2220
 0.2220 0.2220
```

```
Z'*Z
```

```
ans =
```

```
1.0000 -0.0000
-0.0000 1.0000
```

### Example 2

Compute the 1-norm of the matrix  $A*Z$  and determine that it is within a small tolerance.

```
norm(A*Z,1) < 1e-12
ans =
1
```

### Example 3

Compute the rational basis for the null space of the same matrix A.

```
ZR = null(A, 'r')
```

```
ZR =
-2 -3
1 0
0 1
```

```
A*ZR
```

```
ans =
0 0
0 0
0 0
```

### See Also

[orth](#) | [rank](#) | [rref](#) | [svd](#)

# num2cell

---

**Purpose** Convert array to cell array with consistently sized cells

**Syntax**  
`C = num2cell(A)`  
`C = num2cell(A,dim)`

**Description** `C = num2cell(A)` converts array `A` into cell array `C` by placing each element of `A` into a separate cell in `C`. Array `A` need not be numeric.

`C = num2cell(A,dim)` splits the contents of `A` into separate cells of `C`, where `dim` specifies which dimensions of `A` to include in each cell. `dim` can be a scalar or a vector of dimensions. For example, if `A` has 2 rows and 3 columns, then:

- `num2cell(A,1)` creates a 1-by-3 cell array `C`, where each cell contains a 2-by-1 column of `A`.
- `num2cell(A,2)` creates a 2-by-1 cell array `C`, where each cell contains a 1-by-3 row of `A`.
- `num2cell(A,[1 2])` creates a 1-by-1 cell array `C`, where the cell contains the entire array `A`.

## Input Arguments

**A - Input**  
any type of multidimensional array

Input, specified as any type of multidimensional array.

**Data Types**  
`single` | `double` | `int8` | `int16` | `int32` | `int64` | `uint8` | `uint16` | `uint32` | `uint64` | `logical` | `char` | `struct` | `cell` | `function_handle`

**dim - Dimension of A**  
positive integer | positive vector of integers

Dimension of `A`, specified as a positive integer or a vector of positive integers. `dim` must be between 1 and `ndims(A)`.



Elements need not be in numeric order. However, num2cell permutes the dimensions of the arrays in each cell of C to match the order of the specified dimensions.

**Data Types**

double

**Output Arguments**

**C - Resulting array**

cell array

Resulting array, returned as a cell array. The size of C depends on the size of A and the values of dim.

- If dim is not specified, then C is the same size as A.
- If dim is a scalar, then C contains numel(A)/size(A,dim) cells. If dim is 1 or 2, then each cell contains a column or row vector, respectively. If dim > 2, then each cell contains an array whose dimth dimensional length is size(A,dim), and whose other dimensions are all singletons.

For example, given a 4-by-7-by-3 array, A, this figure shows how num2cell creates cells corresponding to dim values of 1, 2, and 3.

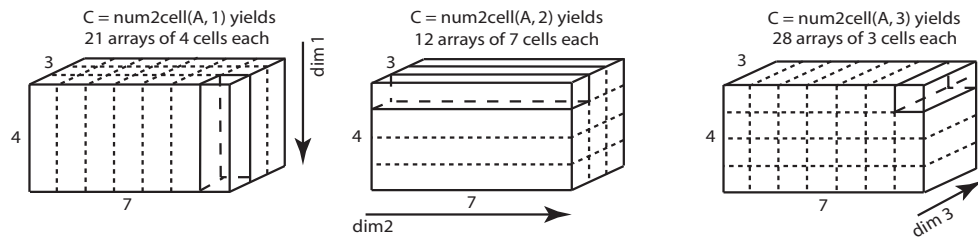

- If dim is a vector containing N values, then C has numel(A)/prod([size(A,dim(1)), ..., size(A,vdim(N))]) cells. Each cell contains an array whose dim(i)th dimension has a length of size(A,dim(i)) and whose other dimensions are singletons.

For example, given a 4-by-7-by-3 array, you can specify dim as an positive integer vector to create cell arrays of different dimensions.

# num2cell

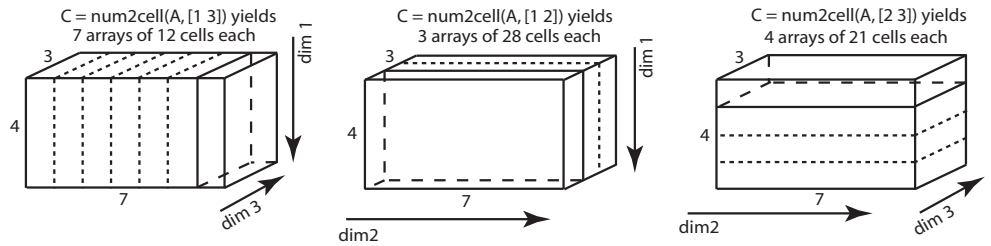

## Examples

### Convert Arrays to Cell Array

Place all elements of a numeric array into separate cells.

```
a = magic(3)
c = num2cell(a)
```

a =

```
8 1 6
3 5 7
4 9 2
```

c =

```
[8] [1] [6]
[3] [5] [7]
[4] [9] [2]
```

Place individual letters of a word into separate cells of an array.

```
a = ['four'; 'five'; 'nine']
c = num2cell(a)
```

a =

```
four
five
nine
```

```
c =
```

```
 'f' 'o' 'u' 'r'
 'f' 'i' 'v' 'e'
 'n' 'i' 'n' 'e'
```

### Create Cell Array of Numeric Arrays

Generate a 4-by-3-by-2 numeric array, and then create a 1-by-3-by-2 cell array of 4-by-1 column vectors.

```
A = reshape(1:12,4,3);
A(:,:,2) = A*10
C = num2cell(A,1)
```

```
A(:,:,1) =
```

```
 1 5 9
 2 6 10
 3 7 11
 4 8 12
```

```
A(:,:,2) =
```

```
 10 50 90
 20 60 100
 30 70 110
 40 80 120
```

# num2cell

---

```
C(:,:,1) =
 [4x1 double] [4x1 double] [4x1 double]
```

```
C(:,:,2) =
 [4x1 double] [4x1 double] [4x1 double]
```

Each 4-by-1 vector contains elements from along the *first* dimension of A:

```
C{1}
```

```
ans =
```

```
 1
 2
 3
 4
```

Create a 4-by-1-by-2 cell array of 1-by-3 numeric arrays.

```
C = num2cell(A,2)
```

```
C(:,:,1) =
 [1x3 double]
 [1x3 double]
 [1x3 double]
 [1x3 double]
```

```
C(:, :, 2) =
```

```

 [1x3 double]
 [1x3 double]
 [1x3 double]
 [1x3 double]

```

Each 1-by-3 row vector contains elements from along the *second* dimension of A:

```
C{1}
```

```
ans =
```

```

 1 5 9

```

Finally, create a 4-by-3 cell array of 1-by-1-by-2 numeric arrays.

```
C = num2cell(A,3)
```

```
C =
```

```

 [1x1x2 double] [1x1x2 double] [1x1x2 double]
 [1x1x2 double] [1x1x2 double] [1x1x2 double]
 [1x1x2 double] [1x1x2 double] [1x1x2 double]
 [1x1x2 double] [1x1x2 double] [1x1x2 double]

```

Each 1-by-1-by-2 vector contains elements from along the *third* dimension of A:

```
C{1}
```

# num2cell

---

```
ans(:,:,1) =
```

```
1
```

```
ans(:,:,2) =
```

```
10
```

## Combine Across Multiple Dimensions

Create a cell array by combining elements into numeric arrays along several dimensions.

```
A = reshape(1:12,4,3);
A(:,:,2) = A*10
c = num2cell(A,[1 3])
```

```
A(:,:,1) =
```

```
1 5 9
2 6 10
3 7 11
4 8 12
```

```
A(:,:,2) =
```

```
10 50 90
20 60 100
30 70 110
40 80 120
```

```
c =

 [4x1x2 double] [4x1x2 double] [4x1x2 double]
```

Each 4-by-1-by-2 array contains elements from along the first and third dimension of A:

```
c{1}
```

```
ans(:,:,1) =

 1
 2
 3
 4
```

```
ans(:,:,2) =

 10
 20
 30
 40
```

```
c = num2cell(A,[2 3])
```

```
c =

 [1x3x2 double]
 [1x3x2 double]
 [1x3x2 double]
 [1x3x2 double]
```

# num2cell

---

## See Also

[cat](#) | [mat2cell](#) | [cell2mat](#)



<b>Purpose</b>	Convert singles and doubles to IEEE hexadecimal strings
<b>Syntax</b>	<code>num2hex(X)</code>
<b>Description</b>	If <code>X</code> is a single or double precision array with <code>n</code> elements, <code>num2hex(X)</code> is an <code>n-by-8</code> or <code>n-by-16</code> char array of the hexadecimal floating-point representation. The same representation is printed with format <code>hex</code> .
<b>Examples</b>	<pre>num2hex([1 0 0.1 -pi Inf NaN])  returns  ans =  3ff0000000000000 0000000000000000 3fb9999999999999a c00921fb54442d18 7ff0000000000000 fff8000000000000 num2hex(single([1 0 0.1 -pi Inf NaN]))  returns  ans =  3f800000 00000000 3dcccccd c0490fdb 7f800000 ffc00000</pre>
<b>See Also</b>	<code>hex2num</code>   <code>dec2hex</code>   <code>format</code>

# num2str

---

**Purpose** Convert number to string

**Syntax**

```
str = num2str(A)
str = num2str(A,precision)
str = num2str(A,formatSpec)
```

**Description** `str = num2str(A)` converts array `A` into a string representation `str`. The output format depends upon the magnitude of the original values and sometimes includes exponents. `num2str` is useful for labeling and titling plots with numeric values.

`str = num2str(A,precision)` returns a string representation with the maximum number of digits specified by `precision`.

`str = num2str(A,formatSpec)` applies a format specified by `formatSpec` to all elements of `A`.

## Input Arguments

### **A - Input array**

scalar | vector | matrix | multidimensional array

Input array, specified as a scalar, vector, matrix, or multidimensional array of real or complex numbers.

### **Data Types**

single | double | int8 | int16 | int32 | int64 | uint8 | uint16 | uint32 | uint64 | logical

### **precision - Numeric precision**

positive integer

Numeric precision of the output string, specified as a positive integer. This is the maximum number of digits in the output string.

### **Data Types**

single | double | int8 | int16 | int32 | int64 | uint8 | uint16 | uint32 | uint64

**formatSpec - Format of the output fields**

string

Format of the output fields, specified as a string.

The string can include a percent sign followed by a conversion character. The following table lists the available conversion characters and subtypes.

Value Type	Conversion	Details
Integer, signed	%d or %i	Base 10
Integer, unsigned	%u	Base 10
	%o	Base 8 (octal)
	%x	Base 16 (hexadecimal), lowercase letters a–f
	%X	Same as %x, uppercase letters A–F
Floating-point number	%f	Fixed-point notation
	%e	Exponential notation, such as 3.141593e+00
	%E	Same as %e, but uppercase, such as 3.141593E+00
	%g	The more compact of %e or %f, with no trailing zeros
	%G	The more compact of %E or %f, with no trailing zeros
	%bx or %bX %bo %bu	Double-precision hexadecimal, octal, or decimal value Example: %bx prints pi as 400921fb54442d18

Value Type	Conversion	Details
	%tx or %tX %to %tu	Single-precision hexadecimal, octal, or decimal value Example: %tx prints pi as 40490fdb
Characters	%c	Single character
	%s	String of characters

The string can include optional operators, which appear in the following order (includes spaces for clarity):

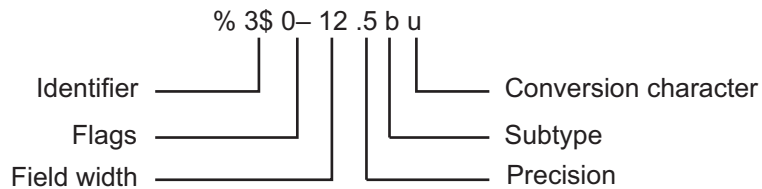

Optional operators include:

- Identifier

Order for processing inputs. Use the syntax `n$`, where `n` represents the position of the value in the input list.

For example, `'%3$s %2$s %1$s %2$s'` prints inputs 'A', 'B', 'C' as follows: C B A B.

- Flags

- ' ' Left-justify. Example: `%-5.2f`
- '+' Print sign character (+) for positive values. Example:  `%+5.2f`
- ' ' Pad to field width with spaces before the value. Example:  `% 5.2f`

'0' Pad to field width with zeros. Example: %05.2f

'#' Modify selected numeric conversions:

- For %o, %x, or %X, print 0, 0x, or 0X prefix.
- For %f, %e, or %E, print decimal point even when precision is 0.
- For %g or %G, do not remove trailing zeros or decimal point.

Example: %#5.0f

- Field width

Minimum number of characters to print. Can be a number, or an asterisk (\*) to refer to an argument in the input list. For example, the input list ('%12d', intmax) is equivalent to ('%\*d', 12, intmax).

- Precision

For %f, %e, or %E: Number of digits to the right of the decimal point.

Example: '%6.4f' prints pi as '3.1416'

For %g or %G: Number of significant digits.

Example: '%6.4g' prints pi as ' 3.142'

Can be a number, or an asterisk (\*) to refer to an argument in the input list. For example, the input list ('%6.4f', pi) is equivalent to ('%\*.\*f', 6, 4, pi).

The string can also include combinations of the following:

- Literal text to print. To print a single quotation mark, include '' in formatSpec.
- Control characters, including:

<code>%%</code>	Percent character
<code>\\</code>	Backslash
<code>\a</code>	Alarm
<code>\b</code>	Backspace
<code>\f</code>	Form feed
<code>\n</code>	New line
<code>\r</code>	Carriage return
<code>\t</code>	Horizontal tab
<code>\v</code>	Vertical tab
<code>\xN</code>	Character whose ASCII code is the hexadecimal number, <i>N</i>
<code>\w</code>	Character whose ASCII code is the octal number, <i>N</i>

The following limitations apply to conversions:

- Numeric conversions print only the real component of complex numbers.
- If you specify a conversion that does not fit the data, such as a string conversion for a numeric value, MATLAB overrides the specified conversion, and uses `%e`.
- If you apply a string conversion (`%s`) to integer values, MATLAB converts values that correspond to valid character codes to characters. For example, `'%s'` converts `[65 66 67]` to `ABC`.

## Output Arguments

### **str** - String representation of input array

character array

String representation of the input array, *A*, returned as a character array.

## Algorithms

num2str trims any leading spaces from a string, even when formatSpec includes a space character flag. For example, num2str(42.67, '%10.2f') returns a 1-by-5 character array '42.67'.

## Examples

### Default Conversions of Floating-Point Values

Convert pi and eps to text strings.

```
str = num2str(pi)
```

```
str =
```

```
3.1416
```

```
str = num2str(eps)
```

```
str =
```

```
2.2204e-16
```

### Specifying Precision

Specify the number of significant digits for floating-point values.

```
A = gallery('normaldata',[2,2],0);
precision = 3;
str = num2str(A,precision)
```

```
str =
```

```
-0.433 0.125
-1.67 0.288
```

## Specifying Formatting

Specify the width, precision, and other formatting for an array of floating-point values.

```
A = gallery('uniformdata',[2,3],0) * 9999;
formatSpec = '%10.5e\n';
str = num2str(A,formatSpec)
```

```
str =

9.50034e+03
6.06782e+03
8.91210e+03
2.31115e+03
4.85934e+03
7.62021e+03
```

The format `'%10.5e'` prints each value in exponential format with five decimal places, and `'\n'` prints a new line character.

## See Also

[cast](#) | [int2str](#) | [mat2str](#) | [sprintf](#) | [str2num](#)



**Purpose** Total number of strips in image

**Syntax** `numStrips = tiffobj.numberOfStrips()`

**Description** `numStrips = tiffobj.numberOfStrips()` returns the total number of strips in the image.

## **Examples Determine Number of Strips in Image**

Determine the number of strips in the second image of a file.

Create a Tiff object associated with the example file, `example.tif`.

```
t = Tiff('example.tif', 'r');
```

When the Tiff object is created, the first image in the file is the current image file directory.

Make the second image the current directory.

```
t.nextDirectory();
```

Get the number of strips in the image if the image has a stripped organization.

```
if ~t.isTiled()
 numStrips = t.numberOfStrips()
end
```

```
numStrips =
```

```
 7
```

The image has 7 strips.

Close the Tiff object.

```
t.close();
```

# Tiff.numberOfStrips

---

## References

This method corresponds to the `TIFFNumberOfStrips` function in the LibTIFF C API. To use this method, you must be familiar with the TIFF specification and technical notes. View this documentation at [LibTIFF - TIFF Library and Utilities](#).

## See Also

`Tiff.numberOfTiles` | `Tiff.isTiled`

## Tutorials

- “Exporting Image Data and Metadata to TIFF Files”
- “Reading Image Data and Metadata from TIFF Files”

**Purpose** Total number of tiles in image

**Syntax** numTiles = tiffobj.numberOfTiles()

**Description** numTiles = tiffobj.numberOfTiles() returns the total number of tiles in the image.

## **Examples** Determine Number of Tiles in Image

Create a Tiff object associated with the example file, `example.tif`. Get the number of tiles in the image if the image has a tiled organization.

```
t = Tiff('example.tif', 'r');
if t.isTiled()
 nTiles = t.numberOfTiles()
end
```

```
nTiles =

 110
```

The image has 110 tiles.

Close the Tiff object.

```
t.close();
```

**References** This method corresponds to the `TIFFNumberOfTiles` function in the LibTIFF C API. To use this method, you must be familiar with the TIFF specification and technical notes. View this documentation at [LibTIFF - TIFF Library and Utilities](#).

**See Also** [Tiff.numberOfStrips](#) | [Tiff.isTiled](#)

**Tutorials**

- “Exporting Image Data and Metadata to TIFF Files”
- “Reading Image Data and Metadata from TIFF Files”

# numel

---

**Purpose** Number of array elements

**Syntax** `n = numel(A)`

**Description** `n = numel(A)` returns the number of elements, `n`, in array `A`, equivalent to `prod(size(A))`.

**Input Arguments** **A - Input array**  
scalar | vector | matrix | multidimensional array

Input array, specified as a scalar, vector, matrix, or multidimensional array. This includes numeric arrays, logical arrays, character arrays, categorical arrays, tables, structure arrays, cell arrays, and object arrays.

## Examples **Number of Elements in 3-D Matrix**

Create a 4-by-4-by-2 matrix.

```
A = magic(4);
A(:,:,2) = A'
```

```
A(:,:,1) =
 16 2 3 13
 5 11 10 8
 9 7 6 12
 4 14 15 1
```

```
A(:,:,2) =
 16 5 9 4
 2 11 7 14
 3 10 6 15
 13 8 12 1
```

`numel` counts 32 elements in the matrix.

```
n = numel(A)
```

```
n =
```

```
 32
```

### Number of Elements in Cell Array of Strings

Create a cell array of strings.

```
A = {'dog','cat','fish','horse'};
```

numel counts 4 string elements in the array.

```
n = numel(A)
```

```
n =
```

```
 4
```

### Number of Elements in Table

Create a table with four variables listing patient information for five people.

```
LastName = {'Smith';'Johnson';'Williams';'Jones';'Brown'};
```

```
Age = [38;43;38;40;49];
```

```
Height = [71;69;64;67;64];
```

```
Weight = [176;163;131;133;119];
```

```
BloodPressure = [124 93; 109 77; 125 83; 117 75; 122 80];
```

```
A = table(Age,Height,Weight,BloodPressure,'RowNames',LastName)
```

```
A =
```

```

 Age Height Weight BloodPressure
 --- -

```

# numel

---

Smith	38	71	176	124	93
Johnson	43	69	163	109	77
Williams	38	64	131	125	83
Jones	40	67	133	117	75
Brown	49	64	119	122	80

Find the number of elements in the table.

```
n = numel(A)
```

```
n =
```

```
20
```

`numel` returns a value equivalent to `prod(size(A))` corresponding to the 5 rows and 4 variables.

## Limitations

- If `A` is a table, `numel` returns the number of elements in the table, `A`, equivalent to `prod(size(A))`. Variables in a table can have multiple columns, but `numel(A)` only accounts for the number of rows and number of variables.

## See Also

[prod](#) | [size](#) | [subsref](#)

## Concepts

- “Caution When Customizing Classes”

**Purpose**

Amount of storage allocated for nonzero matrix elements

**Syntax**

`n = nzmax(S)`

**Description**

`n = nzmax(S)` returns the amount of storage allocated for nonzero elements.

If `S` is a sparse matrix...      `nzmax(S)` is the number of storage locations allocated for the nonzero elements in `S`.

If `S` is a full matrix...      `nzmax(S) = prod(size(S))`.

Often, `nnz(S)` and `nzmax(S)` are the same. But if `S` is created by an operation which produces fill-in matrix elements, such as sparse matrix multiplication or sparse LU factorization, more storage may be allocated than is actually required, and `nzmax(S)` reflects this. Alternatively, `sparse(i, j, s, m, n, nzmax)` or its simpler form, `spalloc(m, n, nzmax)`, can set `nzmax` in anticipation of later fill-in.

**See Also**

`find` | `isa` | `nnz` | `nonzeros` | `size` | `whos`

# ode15i

---

**Purpose** Solve fully implicit differential equations, variable order method

**Syntax**

```
[T,Y] = ode15i(odefun,tspan,y0,yp0)
[T,Y] = ode15i(odefun,tspan,y0,yp0,options)
[T,Y,TE,YE,IE] = ode15i(odefun,tspan,y0,yp0,options...)
sol = ode15i(odefun,[t0 tfinal],y0,yp0,...)
```

**Arguments** The following table lists the input arguments for `ode15i`.

<code>odefun</code>	A function handle that evaluates the left side of the differential equations, which are of the form $f(t,y,y') = 0$ .
<code>tspan</code>	A vector specifying the interval of integration, $[t_0, t_f]$ . To obtain solutions at specific times (all increasing or all decreasing), use <code>tspan = [t0,t1,...,tf]</code> .
<code>y0, yp0</code>	Vectors of initial conditions for $y$ and $y'$ respectively.
<code>options</code>	Optional integration argument created using the <code>odeset</code> function. See <code>odeset</code> for details.

The following table lists the output arguments for `ode15i`.

<code>T</code>	Column vector of time points
<code>Y</code>	Solution array. Each row in $y$ corresponds to the solution at a time returned in the corresponding row of $t$ .

**Description** `[T,Y] = ode15i(odefun,tspan,y0,yp0)` with `tspan = [t0 tf]` integrates the system of differential equations  $f(t,y,y') = 0$  from time  $t_0$  to  $t_f$  with initial conditions  $y_0$  and  $yp_0$ . `odefun` is a function handle. Function `ode15i` solves ODEs and DAEs of index 1. The initial conditions must be consistent, meaning that  $f(t_0,y_0,yp_0) = 0$ . You can use the function `decic` to compute consistent initial conditions close to guessed values. Function `odefun(t,y,yp)`, for a scalar  $t$  and column vectors  $y$  and  $yp$ , must return a column vector corresponding to  $f(t,y,y')$ . Each row in the solution array  $Y$  corresponds to a time returned in the



column vector  $T$ . To obtain solutions at specific times  $t_0, t_1, \dots, t_f$  (all increasing or all decreasing), use  $tspan = [t_0, t_1, \dots, t_f]$ .

“Parameterizing Functions” explains how to provide additional parameters to the function `odefun`, if necessary.

`[T,Y] = ode15i(odefun,tspan,y0,yp0,options)` solves as above with default integration parameters replaced by property values specified in `options`, an argument created with the `odeset` function. Commonly used options include a scalar relative error tolerance `RelTol` ( $1e-3$  by default) and a vector of absolute error tolerances `AbsTol` (all components  $1e-6$  by default). See `odeset` for details.

`[T,Y,TE,YE,IE] = ode15i(odefun,tspan,y0,yp0,options...)` with the 'Events' property in `options` set to a function `events`, solves as above while also finding where functions of  $(t,y,y')$ , called event functions, are zero. The function `events` is of the form `[value,isterminal,direction] = events(t,y,yp)` and includes the necessary event functions. Code the function `events` so that the  $i$ th element of each output vector corresponds to the  $i$ th event. For the  $i$ th event function in `events`:

- `value(i)` is the value of the function.
- `isterminal(i) = 1` if the integration is to terminate at a zero of this event function and 0 otherwise.
- `direction(i) = 0` if all zeros are to be computed (the default), +1 if only the zeros where the event function increases, and -1 if only the zeros where the event function decreases.

Output `TE` is a column vector of times at which events occur. Rows of `YE` are the corresponding solutions, and indices in vector `IE` specify which event occurred. See “Integrator Options” in the MATLAB Mathematics documentation for more information.

`sol = ode15i(odefun,[t0 tfinal],y0,yp0,...)` returns a structure that can be used with `deval` to evaluate the solution at any point between `t0` and `tfinal`. The structure `sol` always includes these fields:

<code>sol.x</code>	Steps chosen by the solver. If you specify the <code>Events</code> option and a terminal event is detected, <code>sol.x(end)</code> contains the end of the step at which the event occurred.
<code>sol.y</code>	Each column <code>sol.y(:,i)</code> contains the solution at <code>sol.x(i)</code> .

If you specify the `Events` option and events are detected, `sol` also includes these fields:

<code>sol.xe</code>	Points at which events, if any, occurred. <code>sol.xe(end)</code> contains the exact point of a terminal event, if any.
<code>sol.ye</code>	Solutions that correspond to events in <code>sol.xe</code> .
<code>sol.ie</code>	Indices into the vector returned by the function specified in the <code>Events</code> option. The values indicate which event the solver detected.

## Options

`ode15i` accepts the following parameters in `options`. For more information, see `odeset` and [Changing ODE Integration Properties](#) in the MATLAB Mathematics documentation.

Error control	<code>RelTol</code> , <code>AbsTol</code> , <code>NormControl</code>
Solver output	<code>OutputFcn</code> , <code>OutputSel</code> , <code>Refine</code> , <code>Stats</code>
Event location	<code>Events</code>
Step size	<code>MaxStep</code> , <code>InitialStep</code>
Jacobian matrix	<code>Jacobian</code> , <code>JPattern</code> , <code>Vectorized</code>

## Solver Output

If you specify an output function as the value of the `OutputFcn` property, the solver calls it with the computed solution after each time step. Four output functions are provided: `odeplot`, `odephas2`, `odephas3`, and `odeprint`. When you call the solver with no output arguments, it calls the default `odeplot` to plot the solution as it is computed. `odephas2` and `odephas3` produce two- and three-dimensional phase plane plots, respectively. `odeprint` displays the solution components on the screen. By default, the ODE solver passes all components of the solution to the output function. You can pass only specific components by providing a vector of indices as the value of the `OutputSel` property. For example, if you call the solver with no output arguments and set the value of `OutputSel` to `[1,3]`, the solver plots solution components 1 and 3 as they are computed.

## Jacobian Matrices

The Jacobian matrices  $\partial f/\partial y$  and  $\partial f/\partial y'$  are critical to reliability and efficiency. You can provide these matrices as one of the following:

- Function of the form `[dfdy,dfdyp] = FJAC(t,y,yp)` that computes the Jacobian matrices. If `FJAC` returns an empty matrix `[]` for either `dfdy` or `dfdyp`, then `ode15i` approximates that matrix by finite differences.
- Cell array of two constant matrices `{dfdy,dfdyp}`, either of which could be empty.

Use `odeset` to set the `Jacobian` option to the function or cell array. If you do not set the `Jacobian` option, `ode15i` approximates both Jacobian matrices by finite differences.

For `ode15i`, `Vectorized` is a two-element cell array. Set the first element to `'on'` if `odefun(t,[y1,y2,...],yp)` returns `[odefun(t,y1,yp),odefun(t,y2,yp),...]`. Set the second element to `'on'` if `odefun(t,y,[yp1,yp2,...])` returns `[odefun(t,y,yp1),odefun(t,y,yp2),...]`. The default value of `Vectorized` is `{'off','off'}`.

For `ode15i`, `JPattern` is also a two-element sparse matrix cell array. If  $\partial f/\partial y$  or  $\partial f/\partial y'$  is a sparse matrix, set `JPattern` to the sparsity patterns, `{SPDY, SPDYP}`. A sparsity pattern of  $\partial f/\partial y$  is a sparse matrix `SPDY` with `SPDY(i,j) = 1` if component `i` of  $f(t,y,yp)$  depends on component `j` of  $y$ , and 0 otherwise. Use `SPDY = []` to indicate that  $\partial f/\partial y$  is a full matrix. Similarly for  $\partial f/\partial y'$  and `SPDYP`. The default value of `JPattern` is `{[], []}`.

## Examples

### Solve Weissinger Implicit ODE

This example uses a helper function, `decic`, to hold fixed the initial value for  $y(t_0)$  and compute a consistent initial value for  $y'(t_0)$  for the Weissinger implicit ODE. The Weissinger function evaluates the residual of the implicit ODE.

```
t0 = 1;
y0 = sqrt(3/2);
yp0 = 0;
[y0,yp0] = decic(@weissinger,t0,y0,1,yp0,0);
```

Use `ode15i` to solve the ODE, and then plot the numerical solution, `y`, against the analytical solution, `ytrue`.

```
[t,y] = ode15i(@weissinger,[1 10],y0,yp0);
ytrue = sqrt(t.^2 + 0.5);
plot(t,y,t,ytrue,'o');
```

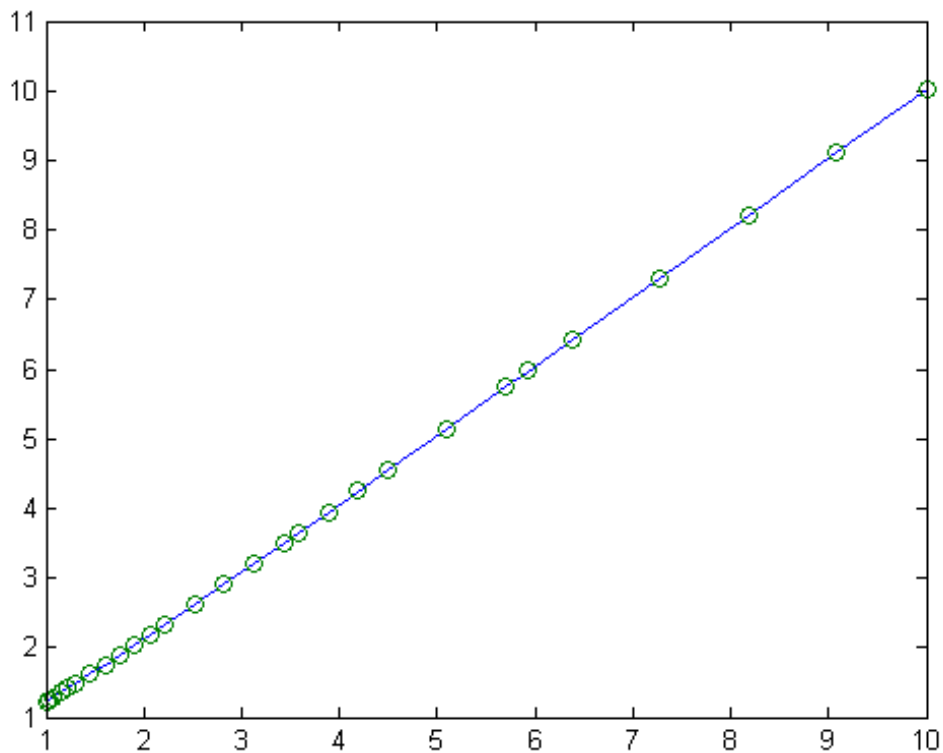

### Other Examples

The files, `ihb1dae.m` and `iburgersode.m`, are examples of implicit ODEs.

### See Also

`decic` | `deval` | `odeget` | `odeset` | `function_handle` | `ode45` | `ode23` | `ode113` | `ode15s` | `ode23s` | `ode23t` | `ode23tb`

**Purpose** Solve stiff differential equations and DAEs; variable order method

**Syntax**

```
[T,Y] = solver(odefun,tspan,y0)
[T,Y] = solver(odefun,tspan,y0,options)
[T,Y,TE,YE,IE] = solver(odefun,tspan,y0,options)
sol = solver(odefun,[t0 tf],y0...)
```

This page contains an overview of the solver functions: `ode23`, `ode45`, `ode113`, `ode15s`, `ode23s`, `ode23t`, and `ode23tb`. You can call any of these solvers by substituting the placeholder, `solver`, with any of the function names.

**Arguments** The following table describes the input arguments to the solvers.

<code>odefun</code>	A function handle that evaluates the right side of the differential equations. All solvers solve systems of equations in the form $y' = f(t,y)$ or problems that involve a mass matrix, $M(t,y)y' = f(t,y)$ . The <code>ode23s</code> solver can solve only equations with constant mass matrices. <code>ode15s</code> and <code>ode23t</code> can solve problems with a mass matrix that is singular, i.e., differential-algebraic equations (DAEs).
<code>tspan</code>	A vector specifying the interval of integration, <code>[t0,tf]</code> . The solver imposes the initial conditions at <code>tspan(1)</code> , and integrates from <code>tspan(1)</code> to <code>tspan(end)</code> . To obtain solutions at specific times (all increasing or all decreasing), use <code>tspan = [t0,t1,...,tf]</code> .  For <code>tspan</code> vectors with two elements <code>[t0 tf]</code> , the solver returns the solution evaluated at every integration step. For <code>tspan</code> vectors with more than two elements, the solver returns solutions evaluated at the given time points. The time values must be in order, either increasing or decreasing.

Specifying `tspan` with more than two elements does not affect the internal time steps that the solver uses to traverse the interval from `tspan(1)` to `tspan(end)`. All solvers in the ODE suite obtain output values by means of continuous extensions of the basic formulas. Although a solver does not necessarily step precisely to a time point specified in `tspan`, the solutions produced at the specified time points are of the same order of accuracy as the solutions computed at the internal time points.

Specifying `tspan` with more than two elements has little effect on the efficiency of computation, but for large systems, affects memory management.

`y0`

A vector of initial conditions.

`options`

Structure of optional parameters that change the default integration properties. This is the fourth input argument.

```
[t,y] = solver(odefun,tspan,y0,options)
```

You can create options using the `odeset` function. See `odeset` for details.

The following table lists the output arguments for the solvers.

<code>T</code>	Column vector of time points.
<code>Y</code>	Solution array. Each row in <code>Y</code> corresponds to the solution at a time returned in the corresponding row of <code>T</code> .
<code>TE</code>	The time at which an event occurs.
<code>YE</code>	The solution at the time of the event.

IE            The index *i* of the event function that vanishes.  
sol           Structure to evaluate the solution.

## Description

`[T,Y] = solver(odefun,tspan,y0)` with `tspan = [t0 tf]` integrates the system of differential equations  $y' = f(t,y)$  from time `t0` to `tf` with initial conditions `y0`. The first input argument, `odefun`, is a function handle. The function,  $f = \text{odefun}(t,y)$ , for a scalar `t` and a column vector `y`, must return a column vector `f` corresponding to  $f(t,y)$ . Each row in the solution array `Y` corresponds to a time returned in column vector `T`. To obtain solutions at the specific times `t0, t1, ..., tf` (all increasing or all decreasing), use `tspan = [t0,t1, ..., tf]`.

“Parameterizing Functions” explains how to provide additional parameters to the function `fun`, if necessary.

`[T,Y] = solver(odefun,tspan,y0,options)` solves as above with default integration parameters replaced by property values specified in `options`, an argument created with the `odeset` function. Commonly used properties include a scalar relative error tolerance `RelTol` ( $1e-3$  by default) and a vector of absolute error tolerances `AbsTol` (all components are  $1e-6$  by default). If certain components of the solution must be nonnegative, use the `odeset` function to set the `NonNegative` property to the indices of these components. See `odeset` for details.

`[T,Y,TE,YE,IE] = solver(odefun,tspan,y0,options)` solves as above while also finding where functions of  $(t,y)$ , called event functions, are zero. For each event function, you specify whether the integration is to terminate at a zero and whether the direction of the zero crossing matters. Do this by setting the 'Events' property to a function, e.g., `events` or `@events`, and creating a function `[value,isterminal,direction] = events(t,y)`. For the *i*th event function in `events`,

- `value(i)` is the value of the function.
- `isterminal(i) = 1`, if the integration is to terminate at a zero of this event function and 0 otherwise.



- `direction(i) = 0` if all zeros are to be computed (the default), `+1` if only the zeros where the event function increases, and `-1` if only the zeros where the event function decreases.

Corresponding entries in `TE`, `YE`, and `IE` return, respectively, the time at which an event occurs, the solution at the time of the event, and the index `i` of the event function that vanishes.

`sol = solver(odefun,[t0 tf],y0...)` returns a structure that you can use with `deval` to evaluate the solution at any point on the interval `[t0,tf]`. You must pass `odefun` as a function handle. The structure `sol` always includes these fields:

<code>sol.x</code>	Steps chosen by the solver.
<code>sol.y</code>	Each column <code>sol.y(:,i)</code> contains the solution at <code>sol.x(i)</code> .
<code>sol.solver</code>	Solver name.

If you specify the `Events` option and events are detected, `sol` also includes these fields:

<code>sol.xe</code>	Points at which events, if any, occurred. <code>sol.xe(end)</code> contains the exact point of a terminal event, if any.
<code>sol.ye</code>	Solutions that correspond to events in <code>sol.xe</code> .
<code>sol.ie</code>	Indices into the vector returned by the function specified in the <code>Events</code> option. The values indicate which event the solver detected.

If you specify an output function as the value of the `OutputFcn` property, the solver calls it with the computed solution after each time step. Four output functions are provided: `odeplot`, `odephas2`, `odephas3`, `odeprint`. When you call the solver with no output arguments, it calls the default `odeplot` to plot the solution as it is computed. `odephas2` and `odephas3` produce two- and three-dimensional phase plane plots, respectively. `odeprint` displays the solution components on the screen.

By default, the ODE solver passes all components of the solution to the output function. You can pass only specific components by providing a vector of indices as the value of the `OutputSel` property. For example, if you call the solver with no output arguments and set the value of `OutputSel` to `[1,3]`, the solver plots solution components 1 and 3 as they are computed.

For the stiff solvers `ode15s`, `ode23s`, `ode23t`, and `ode23tb`, the Jacobian matrix  $\partial f/\partial y$  is critical to reliability and efficiency. Use `odeset` to set `Jacobian` to `@FJAC` if `FJAC(T,Y)` returns the Jacobian  $\partial f/\partial y$  or to the matrix  $\partial f/\partial y$  if the Jacobian is constant. If the `Jacobian` property is not set (the default),  $\partial f/\partial y$  is approximated by finite differences. Set the `Vectorized` property 'on' if the ODE function is coded so that `odefun(T,[Y1,Y2 ...])` returns `[odefun(T,Y1),odefun(T,Y2) ...]`. If  $\partial f/\partial y$  is a sparse matrix, set the `JPattern` property to the sparsity pattern of  $\partial f/\partial y$ , i.e., a sparse matrix `S` with `S(i,j) = 1` if the *i*th component of  $f(t,y)$  depends on the *j*th component of  $y$ , and 0 otherwise.

The solvers of the ODE suite can solve problems of the form  $M(t,y)y' = f(t,y)$ , with time- and state-dependent mass matrix  $M$ . (The `ode23s` solver can solve only equations with constant mass matrices.) If a problem has a mass matrix, create a function `M = MASS(t,y)` that returns the value of the mass matrix, and use `odeset` to set the `Mass` property to `@MASS`. If the mass matrix is constant, the matrix should be used as the value of the `Mass` property. Problems with state-dependent mass matrices are more difficult:

- If the mass matrix does not depend on the state variable  $y$  and the function `MASS` is to be called with one input argument, `t`, set the `MStateDependence` property to 'none'.
- If the mass matrix depends weakly on  $y$ , set `MStateDependence` to 'weak' (the default); otherwise, set it to 'strong'. In either case, the function `MASS` is called with the two arguments `(t,y)`.

If there are many differential equations, it is important to exploit sparsity:

- Return a sparse  $M(t,y)$ .

- Supply the sparsity pattern of  $\partial f/\partial y$  using the JPattern property or a sparse  $\partial f/\partial y$  using the Jacobian property.
- For strongly state-dependent  $M(t,y)$ , set MvPattern to a sparse matrix S with  $S(i, j) = 1$  if for any k, the (i, k) component of  $M(t,y)$  depends on component j of y, and 0 otherwise.

If the mass matrix  $M$  is singular, then  $M(t,y)y' = f(t,y)$  is a system of differential algebraic equations. DAEs have solutions only when  $y_0$  is consistent, that is, if there is a vector  $yp_0$  such that  $M(t_0,y_0)yp_0 = f(t_0,y_0)$ . The ode15s and ode23t solvers can solve DAEs of index 1 provided that  $y_0$  is sufficiently close to being consistent. If there is a mass matrix, you can use odeset to set the MassSingular property to 'yes', 'no', or 'maybe'. The default value of 'maybe' causes the solver to test whether the problem is a DAE. You can provide  $yp_0$  as the value of the InitialSlope property. The default is the zero vector. If a problem is a DAE, and  $y_0$  and  $yp_0$  are not consistent, the solver treats them as guesses, attempts to compute consistent values that are close to the guesses, and continues to solve the problem. When solving DAEs, it is very advantageous to formulate the problem so that  $M$  is a diagonal matrix (a semi-explicit DAE).

Solver	Problem Type	Order of Accuracy	When to Use
ode45	Nonstiff	Medium	Most of the time. This should be the first solver you try.
ode23	Nonstiff	Low	For problems with crude error tolerances or for solving moderately stiff problems.

<b>Solver</b>	<b>Problem Type</b>	<b>Order of Accuracy</b>	<b>When to Use</b>
ode113	Nonstiff	Low to high	For problems with stringent error tolerances or for solving computationally intensive problems.
ode15s	Stiff	Low to medium	If ode45 is slow because the problem is stiff.
ode23s	Stiff	Low	If using crude error tolerances to solve stiff systems and the mass matrix is constant.
ode23t	Moderately Stiff	Low	For moderately stiff problems if you need a solution without numerical damping.
ode23tb	Stiff	Low	If using crude error tolerances to solve stiff systems.

The algorithms used in the ODE solvers vary according to order of accuracy [6] and the type of systems (stiff or nonstiff) they are designed to solve. See “Algorithms” on page 1-4696 for more details.

## Options

Different solvers accept different parameters in the options list. For more information, see `odeset` and “Integrator Options” in the MATLAB Mathematics documentation.

Parameters	ode45	ode23	ode113	ode15s	ode23s	ode23t	ode23tb
RelTol, AbsTol, NormControl	√	√	√	√	√	√	√
OutputFcn, OutputSel, Refine, Stats	√	√	√	√	√	√	√
NonNegative	√	√	√	√ *	—	√ *	√ *
Events	√	√	√	√	√	√	√
MaxStep, InitialStep	√	√	√	√	√	√	√
Jacobian, JPattern, Vectorized	—	—	—	√	√	√	√
Mass	√	√	√	√	√	√	√
MStateDependence	√	√	√	√	—	√	√
MvPattern	—	—	—	√	—	√	√
MassSingular	—	—	—	√	—	√	—
InitialSlope	—	—	—	√	—	√	—
MaxOrder, BDF	—	—	—	√	—	—	—

---

**Note** You can use the NonNegative parameter with ode15s, ode23t, and ode23tb only for those problems for which there is no mass matrix.

---

## Examples

### Example 1

An example of a nonstiff system is the system of equations describing the motion of a rigid body without external forces.

## ode15s

---

$$\begin{aligned}y_1' &= y_2 y_3 & y_1(0) &= 0 \\y_2' &= -y_1 y_3 & y_2(0) &= 1 \\y_3' &= -0.51 y_1 y_2 & y_3(0) &= 1\end{aligned}$$

To simulate this system, create a function `rigid` containing the equations

```
function dy = rigid(t,y)
dy = zeros(3,1); % a column vector
dy(1) = y(2) * y(3);
dy(2) = -y(1) * y(3);
dy(3) = -0.51 * y(1) * y(2);
```

In this example we change the error tolerances using the `odeset` command and solve on a time interval `[0 12]` with an initial condition vector `[0 1 1]` at time 0.

```
options = odeset('RelTol',1e-4,'AbsTol',[1e-4 1e-4 1e-5]);
[T,Y] = ode45(@rigid,[0 12],[0 1 1],options);
```

Plotting the columns of the returned array `Y` versus `T` shows the solution

```
plot(T,Y(:,1),'-',T,Y(:,2),'-.',T,Y(:,3),'.')
```

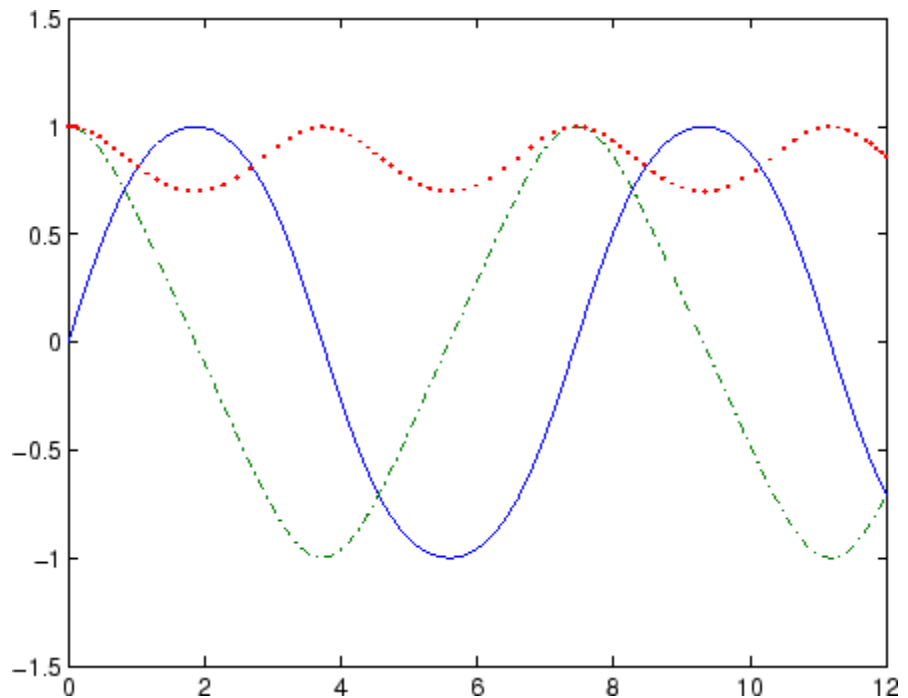

### Example 2

An example of a stiff system is provided by the van der Pol equations in relaxation oscillation. The limit cycle has portions where the solution components change slowly and the problem is quite stiff, alternating with regions of very sharp change where it is not stiff.

$$\begin{aligned} y_1' &= y_2 & y_1(0) &= 2 \\ y_2' &= 1000(1 - y_1^2)y_2 - y_1 & y_2(0) &= 0 \end{aligned}$$

To simulate this system, create a function `vdp1000` containing the equations

```
function dy = vdp1000(t,y)
```

# ode15s

```
dy = zeros(2,1); % a column vector
dy(1) = y(2);
dy(2) = 1000*(1 - y(1)^2)*y(2) - y(1);
```

For this problem, we will use the default relative and absolute tolerances ( $1e-3$  and  $1e-6$ , respectively) and solve on a time interval of  $[0 \ 3000]$  with initial condition vector  $[2 \ 0]$  at time 0.

```
[T,Y] = ode15s(@vdp1000,[0 3000],[2 0]);
```

Plotting the first column of the returned matrix Y versus T shows the solution

```
plot(T,Y(:,1),'-o')
```

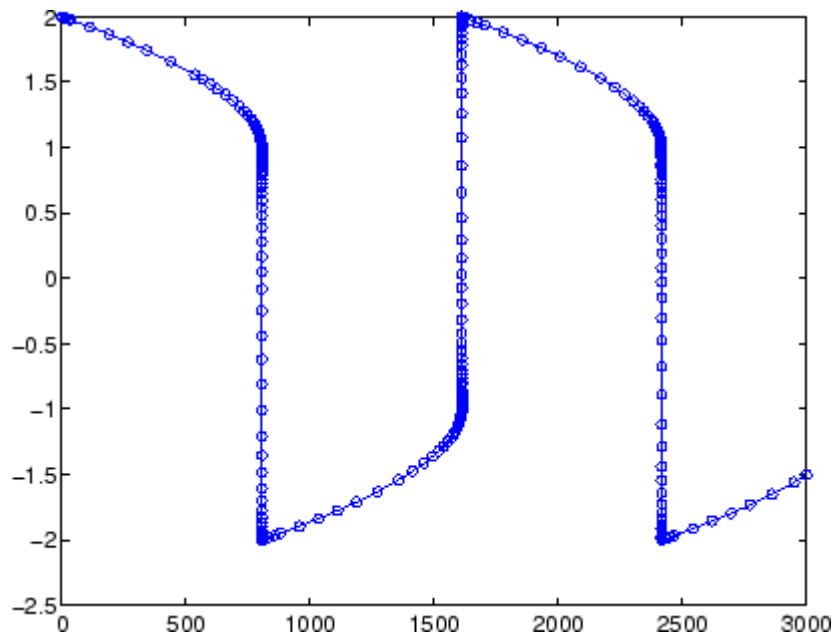



**Example 3**

This example solves an ordinary differential equation with time-dependent terms.

Consider the following ODE, with time-dependent parameters defined only through the set of data points given in two vectors:

$$y'(t) + f(t)y(t) = g(t)$$

The initial condition is  $y(0) = 0$ , where the function  $f(t)$  is defined through the  $n$ -by-1 vectors  $tf$  and  $f$ , and the function  $g(t)$  is defined through the  $m$ -by-1 vectors  $tg$  and  $g$ .

First, define the time-dependent parameters  $f(t)$  and  $g(t)$  as the following:

```
ft = linspace(0,5,25); % Generate t for f
f = ft.^2 - ft - 3; % Generate f(t)
gt = linspace(1,6,25); % Generate t for g
g = 3*sin(gt-0.25); % Generate g(t)
```

Write a function to interpolate the data sets specified above to obtain the value of the time-dependent terms at the specified time:

```
function dydt = myode(t,y,ft,f,gt,g)
f = interp1(ft,f,t); % Interpolate the data set (ft,f) at time t
g = interp1(gt,g,t); % Interpolate the data set (gt,g) at time t
dydt = -f.*y + g; % Evaluate ODE at time t
```

Call the derivative function `myode.m` within the MATLAB `ode45` function specifying time as the first input argument :

```
Tspan = [1 5]; % Solve from t=1 to t=5
IC = 1; % y(t=0) = 1
[T Y] = ode45(@(t,y) myode(t,y,ft,f,gt,g),Tspan,IC); % Solve ODE
```

Plot the solution  $y(t)$  as a function of time:

```
plot(T, Y);
```

```
title('Plot of y as a function of time');
xlabel('Time'); ylabel('Y(t)');
```

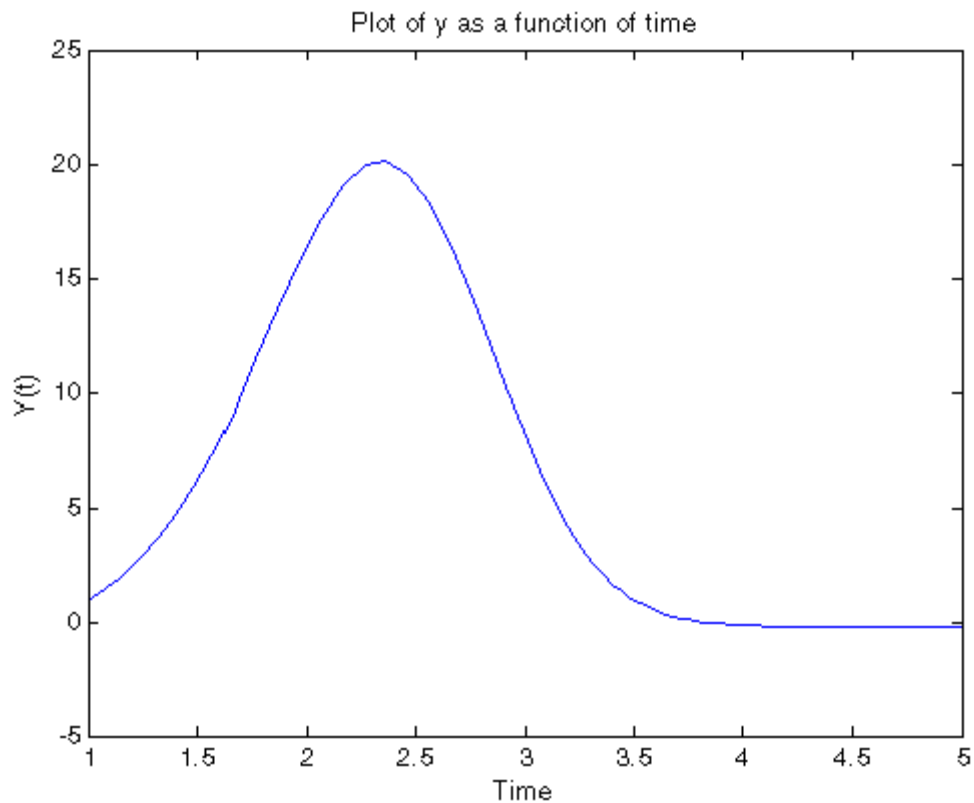

## Algorithms

`ode45` is based on an explicit Runge-Kutta (4,5) formula, the Dormand-Prince pair. It is a *one-step* solver – in computing  $y(t_n)$ , it needs only the solution at the immediately preceding time point,  $y(t_{n-1})$ . In general, `ode45` is the best function to apply as a *first try* for most problems. [3]

`ode23` is an implementation of an explicit Runge-Kutta (2,3) pair of Bogacki and Shampine. It may be more efficient than `ode45` at crude

tolerances and in the presence of moderate stiffness. Like `ode45`, `ode23` is a one-step solver. [2]

`ode113` is a variable order Adams-Bashforth-Moulton PECE solver. It may be more efficient than `ode45` at stringent tolerances and when the ODE file function is particularly expensive to evaluate. `ode113` is a *multistep* solver — it normally needs the solutions at several preceding time points to compute the current solution. [7]

The above algorithms are intended to solve nonstiff systems. If they appear to be unduly slow, try using one of the stiff solvers below.

`ode15s` is a variable order solver based on the numerical differentiation formulas (NDFs). Optionally, it uses the backward differentiation formulas (BDFs, also known as Gear’s method) that are usually less efficient. Like `ode113`, `ode15s` is a multistep solver. Try `ode15s` when `ode45` fails, or is very inefficient, and you suspect that the problem is stiff, or when solving a differential-algebraic problem. [9], [10]

`ode23s` is based on a modified Rosenbrock formula of order 2. Because it is a one-step solver, it may be more efficient than `ode15s` at crude tolerances. It can solve some kinds of stiff problems for which `ode15s` is not effective. [9]

`ode23t` is an implementation of the trapezoidal rule using a “free” interpolant. Use this solver if the problem is only moderately stiff and you need a solution without numerical damping. `ode23t` can solve DAEs. [10]

`ode23tb` is an implementation of TR-BDF2, an implicit Runge-Kutta formula with a first stage that is a trapezoidal rule step and a second stage that is a backward differentiation formula of order two. By construction, the same iteration matrix is used in evaluating both stages. Like `ode23s`, this solver may be more efficient than `ode15s` at crude tolerances. [8], [1]

## References

[1] Bank, R. E., W. C. Coughran, Jr., W. Fichtner, E. Grosse, D. Rose, and R. Smith, “Transient Simulation of Silicon Devices and Circuits,” *IEEE Trans. CAD*, 4 (1985), pp. 436–451.

- [2] Bogacki, P. and L. F. Shampine, “A 3(2) pair of Runge-Kutta formulas,” *Appl. Math. Letters*, Vol. 2, 1989, pp. 321–325.
- [3] Dormand, J. R. and P. J. Prince, “A family of embedded Runge-Kutta formulae,” *J. Comp. Appl. Math.*, Vol. 6, 1980, pp. 19–26.
- [4] Forsythe, G. , M. Malcolm, and C. Moler, *Computer Methods for Mathematical Computations*, Prentice-Hall, New Jersey, 1977.
- [5] Kahaner, D. , C. Moler, and S. Nash, *Numerical Methods and Software*, Prentice-Hall, New Jersey, 1989.
- [6] Shampine, L. F. , *Numerical Solution of Ordinary Differential Equations*, Chapman & Hall, New York, 1994.
- [7] Shampine, L. F. and M. K. Gordon, *Computer Solution of Ordinary Differential Equations: the Initial Value Problem*, W. H. Freeman, San Francisco, 1975.
- [8] Shampine, L. F. and M. E. Hosea, “Analysis and Implementation of TR-BDF2,” *Applied Numerical Mathematics* 20, 1996.
- [9] Shampine, L. F. and M. W. Reichelt, “The MATLAB ODE Suite,” *SIAM Journal on Scientific Computing*, Vol. 18, 1997, pp. 1–22.
- [10] Shampine, L. F., M. W. Reichelt, and J.A. Kierzenka, “Solving Index-1 DAEs in MATLAB and Simulink,” *SIAM Review*, Vol. 41, 1999, pp. 538–552.

## See Also

`deval` | `ode15i` | `odeget` | `odeset` | `function_handle`

**Purpose**

Solve nonstiff differential equations; low order method

**Syntax**

```
[T,Y] = solver(odefun,tspan,y0)
[T,Y] = solver(odefun,tspan,y0,options)
[T,Y,TE,YE,IE] = solver(odefun,tspan,y0,options)
sol = solver(odefun,[t0 tf],y0...)
```

This page contains an overview of the solver functions: `ode23`, `ode45`, `ode113`, `ode15s`, `ode23s`, `ode23t`, and `ode23tb`. You can call any of these solvers by substituting the placeholder, `solver`, with any of the function names.

**Arguments**

The following table describes the input arguments to the solvers.

<code>odefun</code>	A function handle that evaluates the right side of the differential equations. All solvers solve systems of equations in the form $y' = f(t,y)$ or problems that involve a mass matrix, $M(t,y)y' = f(t,y)$ . The <code>ode23s</code> solver can solve only equations with constant mass matrices. <code>ode15s</code> and <code>ode23t</code> can solve problems with a mass matrix that is singular, i.e., differential-algebraic equations (DAEs).
<code>tspan</code>	A vector specifying the interval of integration, <code>[t0,tf]</code> . The solver imposes the initial conditions at <code>tspan(1)</code> , and integrates from <code>tspan(1)</code> to <code>tspan(end)</code> . To obtain solutions at specific times (all increasing or all decreasing), use <code>tspan = [t0,t1,...,tf]</code> .  For <code>tspan</code> vectors with two elements <code>[t0 tf]</code> , the solver returns the solution evaluated at every integration step. For <code>tspan</code> vectors with more than two elements, the solver returns solutions evaluated at the given time points. The time values must be in order, either increasing or decreasing.

Specifying `tspan` with more than two elements does not affect the internal time steps that the solver uses to traverse the interval from `tspan(1)` to `tspan(end)`. All solvers in the ODE suite obtain output values by means of continuous extensions of the basic formulas. Although a solver does not necessarily step precisely to a time point specified in `tspan`, the solutions produced at the specified time points are of the same order of accuracy as the solutions computed at the internal time points.

Specifying `tspan` with more than two elements has little effect on the efficiency of computation, but for large systems, affects memory management.

`y0`

A vector of initial conditions.

`options`

Structure of optional parameters that change the default integration properties. This is the fourth input argument.

```
[t,y] = solver(odefun,tspan,y0,options)
```

You can create options using the `odeset` function. See `odeset` for details.

The following table lists the output arguments for the solvers.

T	Column vector of time points.
Y	Solution array. Each row in Y corresponds to the solution at a time returned in the corresponding row of T.
TE	The time at which an event occurs.
YE	The solution at the time of the event.

IE            The index *i* of the event function that vanishes.  
 sol          Structure to evaluate the solution.

## Description

$[T, Y] = \text{solver}(\text{odefun}, \text{tspan}, y_0)$  with  $\text{tspan} = [t_0 \text{ } t_f]$  integrates the system of differential equations  $y' = f(t, y)$  from time  $t_0$  to  $t_f$  with initial conditions  $y_0$ . The first input argument, `odefun`, is a function handle. The function,  $f = \text{odefun}(t, y)$ , for a scalar  $t$  and a column vector  $y$ , must return a column vector  $f$  corresponding to  $f(t, y)$ . Each row in the solution array  $Y$  corresponds to a time returned in column vector  $T$ . To obtain solutions at the specific times  $t_0, t_1, \dots, t_f$  (all increasing or all decreasing), use  $\text{tspan} = [t_0, t_1, \dots, t_f]$ .

“Parameterizing Functions” explains how to provide additional parameters to the function `fun`, if necessary.

$[T, Y] = \text{solver}(\text{odefun}, \text{tspan}, y_0, \text{options})$  solves as above with default integration parameters replaced by property values specified in `options`, an argument created with the `odeset` function. Commonly used properties include a scalar relative error tolerance `RelTol` ( $1e-3$  by default) and a vector of absolute error tolerances `AbsTol` (all components are  $1e-6$  by default). If certain components of the solution must be nonnegative, use the `odeset` function to set the `NonNegative` property to the indices of these components. See `odeset` for details.

$[T, Y, TE, YE, IE] = \text{solver}(\text{odefun}, \text{tspan}, y_0, \text{options})$  solves as above while also finding where functions of  $(t, y)$ , called event functions, are zero. For each event function, you specify whether the integration is to terminate at a zero and whether the direction of the zero crossing matters. Do this by setting the 'Events' property to a function, e.g., `events` or `@events`, and creating a function  $[\text{value}, \text{isterminal}, \text{direction}] = \text{events}(t, y)$ . For the  $i$ th event function in `events`,

- `value(i)` is the value of the function.
- `isterminal(i) = 1`, if the integration is to terminate at a zero of this event function and 0 otherwise.

- `direction(i)` = 0 if all zeros are to be computed (the default), +1 if only the zeros where the event function increases, and -1 if only the zeros where the event function decreases.

Corresponding entries in `TE`, `YE`, and `IE` return, respectively, the time at which an event occurs, the solution at the time of the event, and the index `i` of the event function that vanishes.

`sol = solver(odefun,[t0 tf],y0...)` returns a structure that you can use with `deval` to evaluate the solution at any point on the interval `[t0,tf]`. You must pass `odefun` as a function handle. The structure `sol` always includes these fields:

<code>sol.x</code>	Steps chosen by the solver.
<code>sol.y</code>	Each column <code>sol.y(:,i)</code> contains the solution at <code>sol.x(i)</code> .
<code>sol.solver</code>	Solver name.

If you specify the `Events` option and events are detected, `sol` also includes these fields:

<code>sol.xe</code>	Points at which events, if any, occurred. <code>sol.xe(end)</code> contains the exact point of a terminal event, if any.
<code>sol.ye</code>	Solutions that correspond to events in <code>sol.xe</code> .
<code>sol.ie</code>	Indices into the vector returned by the function specified in the <code>Events</code> option. The values indicate which event the solver detected.

If you specify an output function as the value of the `OutputFcn` property, the solver calls it with the computed solution after each time step. Four output functions are provided: `odeplot`, `odephas2`, `odephas3`, `odeprint`. When you call the solver with no output arguments, it calls the default `odeplot` to plot the solution as it is computed. `odephas2` and `odephas3` produce two- and three-dimensional phase plane plots, respectively. `odeprint` displays the solution components on the screen.



By default, the ODE solver passes all components of the solution to the output function. You can pass only specific components by providing a vector of indices as the value of the `OutputSel` property. For example, if you call the solver with no output arguments and set the value of `OutputSel` to `[1,3]`, the solver plots solution components 1 and 3 as they are computed.

For the stiff solvers `ode15s`, `ode23s`, `ode23t`, and `ode23tb`, the Jacobian matrix  $\partial f/\partial y$  is critical to reliability and efficiency. Use `odeset` to set `Jacobian` to `@FJAC` if `FJAC(T,Y)` returns the Jacobian  $\partial f/\partial y$  or to the matrix  $\partial f/\partial y$  if the Jacobian is constant. If the `Jacobian` property is not set (the default),  $\partial f/\partial y$  is approximated by finite differences. Set the `Vectorized` property 'on' if the ODE function is coded so that `odefun(T,[Y1,Y2 ...])` returns `[odefun(T,Y1),odefun(T,Y2) ...]`. If  $\partial f/\partial y$  is a sparse matrix, set the `JPattern` property to the sparsity pattern of  $\partial f/\partial y$ , i.e., a sparse matrix `S` with `S(i,j) = 1` if the *i*th component of  $f(t,y)$  depends on the *j*th component of  $y$ , and 0 otherwise.

The solvers of the ODE suite can solve problems of the form  $M(t,y)y' = f(t,y)$ , with time- and state-dependent mass matrix  $M$ . (The `ode23s` solver can solve only equations with constant mass matrices.) If a problem has a mass matrix, create a function `M = MASS(t,y)` that returns the value of the mass matrix, and use `odeset` to set the `Mass` property to `@MASS`. If the mass matrix is constant, the matrix should be used as the value of the `Mass` property. Problems with state-dependent mass matrices are more difficult:

- If the mass matrix does not depend on the state variable  $y$  and the function `MASS` is to be called with one input argument, `t`, set the `MStateDependence` property to 'none'.
- If the mass matrix depends weakly on  $y$ , set `MStateDependence` to 'weak' (the default); otherwise, set it to 'strong'. In either case, the function `MASS` is called with the two arguments `(t,y)`.

If there are many differential equations, it is important to exploit sparsity:

- Return a sparse  $M(t,y)$ .

- Supply the sparsity pattern of  $\partial f/\partial y$  using the `JPattern` property or a sparse  $\partial f/\partial y$  using the `Jacobian` property.
- For strongly state-dependent  $M(t,y)$ , set `MVPattern` to a sparse matrix `S` with `S(i,j) = 1` if for any `k`, the `(i,k)` component of  $M(t,y)$  depends on component `j` of `y`, and `0` otherwise.

If the mass matrix  $M$  is singular, then  $M(t,y)y' = f(t,y)$  is a system of differential algebraic equations. DAEs have solutions only when  $y_0$  is consistent, that is, if there is a vector  $yp_0$  such that  $M(t_0,y_0)yp_0 = f(t_0,y_0)$ . The `ode15s` and `ode23t` solvers can solve DAEs of index 1 provided that  $y_0$  is sufficiently close to being consistent. If there is a mass matrix, you can use `odeset` to set the `MassSingular` property to 'yes', 'no', or 'maybe'. The default value of 'maybe' causes the solver to test whether the problem is a DAE. You can provide `yp0` as the value of the `InitialSlope` property. The default is the zero vector. If a problem is a DAE, and  $y_0$  and  $yp_0$  are not consistent, the solver treats them as guesses, attempts to compute consistent values that are close to the guesses, and continues to solve the problem. When solving DAEs, it is very advantageous to formulate the problem so that  $M$  is a diagonal matrix (a semi-explicit DAE).

Solver	Problem Type	Order of Accuracy	When to Use
ode45	Nonstiff	Medium	Most of the time. This should be the first solver you try.
ode23	Nonstiff	Low	For problems with crude error tolerances or for solving moderately stiff problems.

<b>Solver</b>	<b>Problem Type</b>	<b>Order of Accuracy</b>	<b>When to Use</b>
ode113	Nonstiff	Low to high	For problems with stringent error tolerances or for solving computationally intensive problems.
ode15s	Stiff	Low to medium	If ode45 is slow because the problem is stiff.
ode23s	Stiff	Low	If using crude error tolerances to solve stiff systems and the mass matrix is constant.
ode23t	Moderately Stiff	Low	For moderately stiff problems if you need a solution without numerical damping.
ode23tb	Stiff	Low	If using crude error tolerances to solve stiff systems.

The algorithms used in the ODE solvers vary according to order of accuracy [6] and the type of systems (stiff or nonstiff) they are designed to solve. See “Algorithms” on page 1-4711 for more details.

## Options

Different solvers accept different parameters in the options list. For more information, see `odeset` and “Integrator Options” in the MATLAB Mathematics documentation.

# ode23

Parameters	ode45	ode23	ode113	ode15s	ode23s	ode23t	ode23tb
RelTol, AbsTol, NormControl	√	√	√	√	√	√	√
OutputFcn, OutputSel, Refine, Stats	√	√	√	√	√	√	√
NonNegative	√	√	√	√ *	—	√ *	√ *
Events	√	√	√	√	√	√	√
MaxStep, InitialStep	√	√	√	√	√	√	√
Jacobian, JPattern, Vectorized	—	—	—	√	√	√	√
Mass	√	√	√	√	√	√	√
MStateDependence	√	√	√	√	—	√	√
MvPattern	—	—	—	√	—	√	√
MassSingular	—	—	—	√	—	√	—
InitialSlope	—	—	—	√	—	√	—
MaxOrder, BDF	—	—	—	√	—	—	—

---

**Note** You can use the NonNegative parameter with ode15s, ode23t, and ode23tb only for those problems for which there is no mass matrix.

---

## Examples

### Example 1

An example of a nonstiff system is the system of equations describing the motion of a rigid body without external forces.

$$\begin{aligned}y_1' &= y_2 y_3 & y_1(0) &= 0 \\y_2' &= -y_1 y_3 & y_2(0) &= 1 \\y_3' &= -0.51 y_1 y_2 & y_3(0) &= 1\end{aligned}$$

To simulate this system, create a function `rigid` containing the equations

```
function dy = rigid(t,y)
dy = zeros(3,1); % a column vector
dy(1) = y(2) * y(3);
dy(2) = -y(1) * y(3);
dy(3) = -0.51 * y(1) * y(2);
```

In this example we change the error tolerances using the `odeset` command and solve on a time interval `[0 12]` with an initial condition vector `[0 1 1]` at time 0.

```
options = odeset('RelTol',1e-4,'AbsTol',[1e-4 1e-4 1e-5]);
[T,Y] = ode45(@rigid,[0 12],[0 1 1],options);
```

Plotting the columns of the returned array `Y` versus `T` shows the solution

```
plot(T,Y(:,1),'-',T,Y(:,2),'-.',T,Y(:,3),'-.')
```

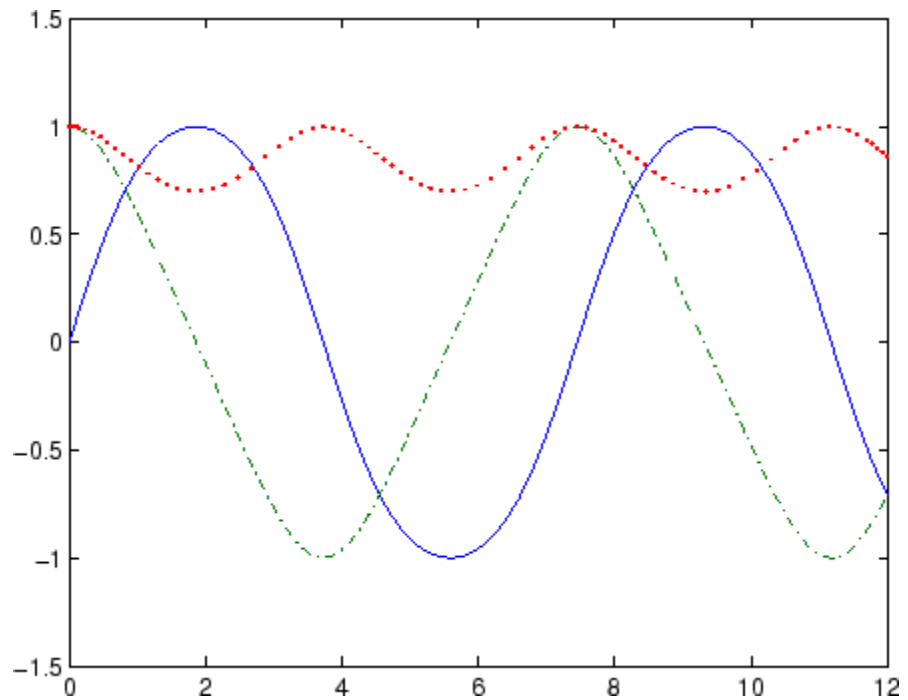

### Example 2

An example of a stiff system is provided by the van der Pol equations in relaxation oscillation. The limit cycle has portions where the solution components change slowly and the problem is quite stiff, alternating with regions of very sharp change where it is not stiff.

$$\begin{aligned}y_1' &= y_2 & y_1(0) &= 2 \\y_2' &= 1000(1 - y_1^2)y_2 - y_1 & y_2(0) &= 0\end{aligned}$$

To simulate this system, create a function `vdp1000` containing the equations

```
function dy = vdp1000(t,y)
```

```
dy = zeros(2,1); % a column vector
dy(1) = y(2);
dy(2) = 1000*(1 - y(1)^2)*y(2) - y(1);
```

For this problem, we will use the default relative and absolute tolerances ( $1e-3$  and  $1e-6$ , respectively) and solve on a time interval of  $[0 \ 3000]$  with initial condition vector  $[2 \ 0]$  at time 0.

```
[T,Y] = ode15s(@vdp1000,[0 3000],[2 0]);
```

Plotting the first column of the returned matrix Y versus T shows the solution

```
plot(T,Y(:,1),'-o')
```

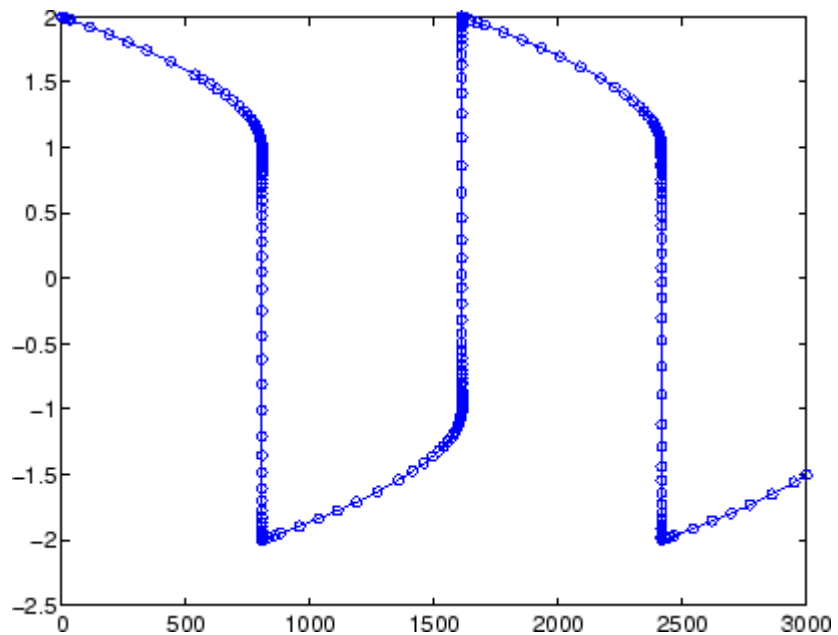

## Example 3

This example solves an ordinary differential equation with time-dependent terms.

Consider the following ODE, with time-dependent parameters defined only through the set of data points given in two vectors:

$$y'(t) + f(t)y(t) = g(t)$$

The initial condition is  $y(0) = 0$ , where the function  $f(t)$  is defined through the  $n$ -by-1 vectors  $tf$  and  $f$ , and the function  $g(t)$  is defined through the  $m$ -by-1 vectors  $tg$  and  $g$ .

First, define the time-dependent parameters  $f(t)$  and  $g(t)$  as the following:

```
ft = linspace(0,5,25); % Generate t for f
f = ft.^2 - ft - 3; % Generate f(t)
gt = linspace(1,6,25); % Generate t for g
g = 3*sin(gt-0.25); % Generate g(t)
```

Write a function to interpolate the data sets specified above to obtain the value of the time-dependent terms at the specified time:

```
function dydt = myode(t,y,ft,f,gt,g)
f = interp1(ft,f,t); % Interpolate the data set (ft,f) at time t
g = interp1(gt,g,t); % Interpolate the data set (gt,g) at time t
dydt = -f.*y + g; % Evaluate ODE at time t
```

Call the derivative function `myode.m` within the MATLAB `ode45` function specifying time as the first input argument :

```
Tspan = [1 5]; % Solve from t=1 to t=5
IC = 1; % y(t=0) = 1
[T Y] = ode45(@(t,y) myode(t,y,ft,f,gt,g),Tspan,IC); % Solve ODE
```

Plot the solution  $y(t)$  as a function of time:

```
plot(T, Y);
```



```
title('Plot of y as a function of time');
xlabel('Time'); ylabel('Y(t)');
```

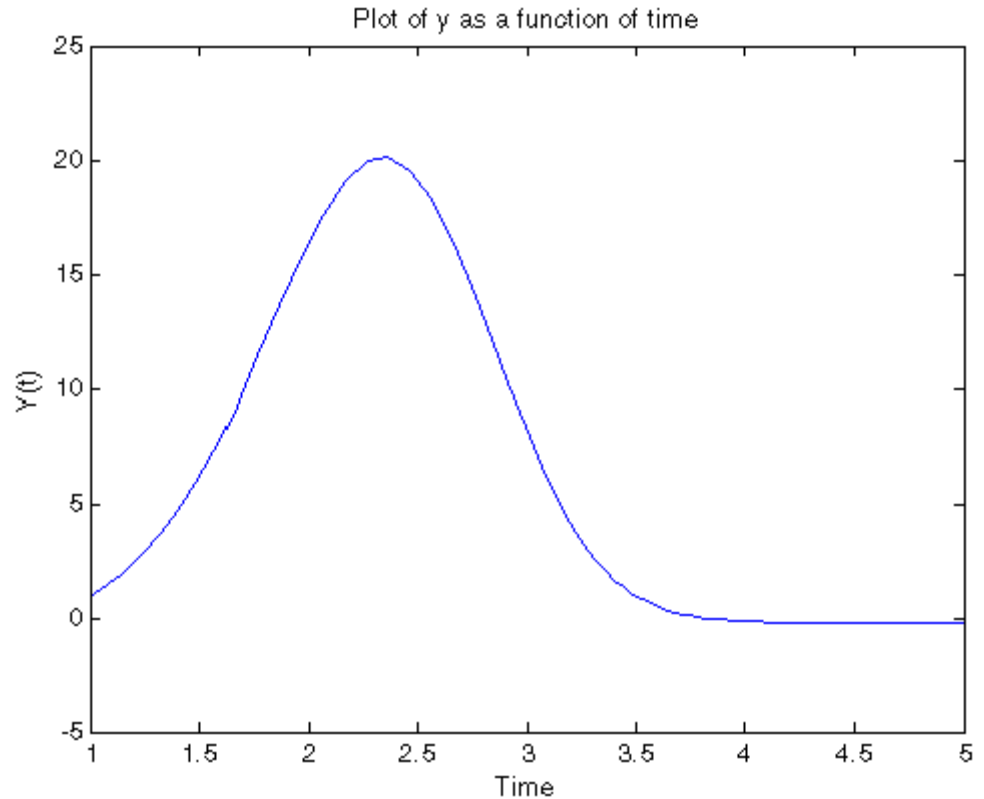

## Algorithms

`ode45` is based on an explicit Runge-Kutta (4,5) formula, the Dormand-Prince pair. It is a *one-step* solver – in computing  $y(t_n)$ , it needs only the solution at the immediately preceding time point,  $y(t_{n-1})$ . In general, `ode45` is the best function to apply as a *first try* for most problems. [3]

`ode23` is an implementation of an explicit Runge-Kutta (2,3) pair of Bogacki and Shampine. It may be more efficient than `ode45` at crude

tolerances and in the presence of moderate stiffness. Like `ode45`, `ode23` is a one-step solver. [2]

`ode113` is a variable order Adams-Bashforth-Moulton PECE solver. It may be more efficient than `ode45` at stringent tolerances and when the ODE file function is particularly expensive to evaluate. `ode113` is a *multistep* solver — it normally needs the solutions at several preceding time points to compute the current solution. [7]

The above algorithms are intended to solve nonstiff systems. If they appear to be unduly slow, try using one of the stiff solvers below.

`ode15s` is a variable order solver based on the numerical differentiation formulas (NDFs). Optionally, it uses the backward differentiation formulas (BDFs, also known as Gear's method) that are usually less efficient. Like `ode113`, `ode15s` is a multistep solver. Try `ode15s` when `ode45` fails, or is very inefficient, and you suspect that the problem is stiff, or when solving a differential-algebraic problem. [9], [10]

`ode23s` is based on a modified Rosenbrock formula of order 2. Because it is a one-step solver, it may be more efficient than `ode15s` at crude tolerances. It can solve some kinds of stiff problems for which `ode15s` is not effective. [9]

`ode23t` is an implementation of the trapezoidal rule using a “free” interpolant. Use this solver if the problem is only moderately stiff and you need a solution without numerical damping. `ode23t` can solve DAEs. [10]

`ode23tb` is an implementation of TR-BDF2, an implicit Runge-Kutta formula with a first stage that is a trapezoidal rule step and a second stage that is a backward differentiation formula of order two. By construction, the same iteration matrix is used in evaluating both stages. Like `ode23s`, this solver may be more efficient than `ode15s` at crude tolerances. [8], [1]

## References

[1] Bank, R. E., W. C. Coughran, Jr., W. Fichtner, E. Grosse, D. Rose, and R. Smith, “Transient Simulation of Silicon Devices and Circuits,” *IEEE Trans. CAD*, 4 (1985), pp. 436–451.

- [2] Bogacki, P. and L. F. Shampine, “A 3(2) pair of Runge-Kutta formulas,” *Appl. Math. Letters*, Vol. 2, 1989, pp. 321–325.
- [3] Dormand, J. R. and P. J. Prince, “A family of embedded Runge-Kutta formulae,” *J. Comp. Appl. Math.*, Vol. 6, 1980, pp. 19–26.
- [4] Forsythe, G. , M. Malcolm, and C. Moler, *Computer Methods for Mathematical Computations*, Prentice-Hall, New Jersey, 1977.
- [5] Kahaner, D. , C. Moler, and S. Nash, *Numerical Methods and Software*, Prentice-Hall, New Jersey, 1989.
- [6] Shampine, L. F. , *Numerical Solution of Ordinary Differential Equations*, Chapman & Hall, New York, 1994.
- [7] Shampine, L. F. and M. K. Gordon, *Computer Solution of Ordinary Differential Equations: the Initial Value Problem*, W. H. Freeman, San Francisco, 1975.
- [8] Shampine, L. F. and M. E. Hosea, “Analysis and Implementation of TR-BDF2,” *Applied Numerical Mathematics* 20, 1996.
- [9] Shampine, L. F. and M. W. Reichelt, “The MATLAB ODE Suite,” *SIAM Journal on Scientific Computing*, Vol. 18, 1997, pp. 1–22.
- [10] Shampine, L. F., M. W. Reichelt, and J.A. Kierzenka, “Solving Index-1 DAEs in MATLAB and Simulink,” *SIAM Review*, Vol. 41, 1999, pp. 538–552.

**See Also**

deval | ode15i | odeget | odeset | function\_handle

**Purpose** Solve stiff differential equations; low order method

**Syntax**

```
[T,Y] = solver(odefun,tspan,y0)
[T,Y] = solver(odefun,tspan,y0,options)
[T,Y,TE,YE,IE] = solver(odefun,tspan,y0,options)
sol = solver(odefun,[t0 tf],y0...)
```

This page contains an overview of the solver functions: `ode23`, `ode45`, `ode113`, `ode15s`, `ode23s`, `ode23t`, and `ode23tb`. You can call any of these solvers by substituting the placeholder, `solver`, with any of the function names.

**Arguments** The following table describes the input arguments to the solvers.

<code>odefun</code>	A function handle that evaluates the right side of the differential equations. All solvers solve systems of equations in the form $y' = f(t,y)$ or problems that involve a mass matrix, $M(t,y)y' = f(t,y)$ . The <code>ode23s</code> solver can solve only equations with constant mass matrices. <code>ode15s</code> and <code>ode23t</code> can solve problems with a mass matrix that is singular, i.e., differential-algebraic equations (DAEs).
<code>tspan</code>	A vector specifying the interval of integration, <code>[t0,tf]</code> . The solver imposes the initial conditions at <code>tspan(1)</code> , and integrates from <code>tspan(1)</code> to <code>tspan(end)</code> . To obtain solutions at specific times (all increasing or all decreasing), use <code>tspan = [t0,t1,...,tf]</code> .  For <code>tspan</code> vectors with two elements <code>[t0 tf]</code> , the solver returns the solution evaluated at every integration step. For <code>tspan</code> vectors with more than two elements, the solver returns solutions evaluated at the given time points. The time values must be in order, either increasing or decreasing.

Specifying `tspan` with more than two elements does not affect the internal time steps that the solver uses to traverse the interval from `tspan(1)` to `tspan(end)`. All solvers in the ODE suite obtain output values by means of continuous extensions of the basic formulas. Although a solver does not necessarily step precisely to a time point specified in `tspan`, the solutions produced at the specified time points are of the same order of accuracy as the solutions computed at the internal time points.

Specifying `tspan` with more than two elements has little effect on the efficiency of computation, but for large systems, affects memory management.

`y0`

A vector of initial conditions.

`options`

Structure of optional parameters that change the default integration properties. This is the fourth input argument.

```
[t,y] = solver(odefun,tspan,y0,options)
```

You can create options using the `odeset` function. See `odeset` for details.

The following table lists the output arguments for the solvers.

<code>T</code>	Column vector of time points.
<code>Y</code>	Solution array. Each row in <code>Y</code> corresponds to the solution at a time returned in the corresponding row of <code>T</code> .
<code>TE</code>	The time at which an event occurs.
<code>YE</code>	The solution at the time of the event.

IE            The index *i* of the event function that vanishes.  
sol           Structure to evaluate the solution.

## Description

`[T,Y] = solver(odefun,tspan,y0)` with `tspan = [t0 tf]` integrates the system of differential equations  $y' = f(t,y)$  from time `t0` to `tf` with initial conditions `y0`. The first input argument, `odefun`, is a function handle. The function,  $f = \text{odefun}(t,y)$ , for a scalar `t` and a column vector `y`, must return a column vector `f` corresponding to  $f(t,y)$ . Each row in the solution array `Y` corresponds to a time returned in column vector `T`. To obtain solutions at the specific times `t0, t1, ..., tf` (all increasing or all decreasing), use `tspan = [t0,t1, ..., tf]`.

“Parameterizing Functions” explains how to provide additional parameters to the function `fun`, if necessary.

`[T,Y] = solver(odefun,tspan,y0,options)` solves as above with default integration parameters replaced by property values specified in `options`, an argument created with the `odeset` function. Commonly used properties include a scalar relative error tolerance `RelTol` ( $1e-3$  by default) and a vector of absolute error tolerances `AbsTol` (all components are  $1e-6$  by default). If certain components of the solution must be nonnegative, use the `odeset` function to set the `NonNegative` property to the indices of these components. See `odeset` for details.

`[T,Y,TE,YE,IE] = solver(odefun,tspan,y0,options)` solves as above while also finding where functions of  $(t,y)$ , called event functions, are zero. For each event function, you specify whether the integration is to terminate at a zero and whether the direction of the zero crossing matters. Do this by setting the 'Events' property to a function, e.g., `events` or `@events`, and creating a function `[value,isterminal,direction] = events(t,y)`. For the *i*th event function in `events`,

- `value(i)` is the value of the function.
- `isterminal(i) = 1`, if the integration is to terminate at a zero of this event function and 0 otherwise.

- `direction(i) = 0` if all zeros are to be computed (the default), `+1` if only the zeros where the event function increases, and `-1` if only the zeros where the event function decreases.

Corresponding entries in `TE`, `YE`, and `IE` return, respectively, the time at which an event occurs, the solution at the time of the event, and the index `i` of the event function that vanishes.

`sol = solver(odefun,[t0 tf],y0...)` returns a structure that you can use with `deval` to evaluate the solution at any point on the interval `[t0,tf]`. You must pass `odefun` as a function handle. The structure `sol` always includes these fields:

<code>sol.x</code>	Steps chosen by the solver.
<code>sol.y</code>	Each column <code>sol.y(:,i)</code> contains the solution at <code>sol.x(i)</code> .
<code>sol.solver</code>	Solver name.

If you specify the `Events` option and events are detected, `sol` also includes these fields:

<code>sol.xe</code>	Points at which events, if any, occurred. <code>sol.xe(end)</code> contains the exact point of a terminal event, if any.
<code>sol.ye</code>	Solutions that correspond to events in <code>sol.xe</code> .
<code>sol.ie</code>	Indices into the vector returned by the function specified in the <code>Events</code> option. The values indicate which event the solver detected.

If you specify an output function as the value of the `OutputFcn` property, the solver calls it with the computed solution after each time step. Four output functions are provided: `odeplot`, `odephas2`, `odephas3`, `odeprint`. When you call the solver with no output arguments, it calls the default `odeplot` to plot the solution as it is computed. `odephas2` and `odephas3` produce two- and three-dimensional phase plane plots, respectively. `odeprint` displays the solution components on the screen.

By default, the ODE solver passes all components of the solution to the output function. You can pass only specific components by providing a vector of indices as the value of the `OutputSel` property. For example, if you call the solver with no output arguments and set the value of `OutputSel` to `[1,3]`, the solver plots solution components 1 and 3 as they are computed.

For the stiff solvers `ode15s`, `ode23s`, `ode23t`, and `ode23tb`, the Jacobian matrix  $\partial f/\partial y$  is critical to reliability and efficiency. Use `odeset` to set `Jacobian` to `@FJAC` if `FJAC(T,Y)` returns the Jacobian  $\partial f/\partial y$  or to the matrix  $\partial f/\partial y$  if the Jacobian is constant. If the `Jacobian` property is not set (the default),  $\partial f/\partial y$  is approximated by finite differences. Set the `Vectorized` property 'on' if the ODE function is coded so that `odefun(T,[Y1,Y2 ...])` returns `[odefun(T,Y1),odefun(T,Y2) ...]`. If  $\partial f/\partial y$  is a sparse matrix, set the `JPattern` property to the sparsity pattern of  $\partial f/\partial y$ , i.e., a sparse matrix `S` with `S(i,j) = 1` if the *i*th component of  $f(t,y)$  depends on the *j*th component of  $y$ , and 0 otherwise.

The solvers of the ODE suite can solve problems of the form  $M(t,y)y' = f(t,y)$ , with time- and state-dependent mass matrix  $M$ . (The `ode23s` solver can solve only equations with constant mass matrices.) If a problem has a mass matrix, create a function `M = MASS(t,y)` that returns the value of the mass matrix, and use `odeset` to set the `Mass` property to `@MASS`. If the mass matrix is constant, the matrix should be used as the value of the `Mass` property. Problems with state-dependent mass matrices are more difficult:

- If the mass matrix does not depend on the state variable  $y$  and the function `MASS` is to be called with one input argument, `t`, set the `MStateDependence` property to 'none'.
- If the mass matrix depends weakly on  $y$ , set `MStateDependence` to 'weak' (the default); otherwise, set it to 'strong'. In either case, the function `MASS` is called with the two arguments `(t,y)`.

If there are many differential equations, it is important to exploit sparsity:

- Return a sparse  $M(t,y)$ .



- Supply the sparsity pattern of  $\partial f/\partial y$  using the `JPattern` property or a sparse  $\partial f/\partial y$  using the `Jacobian` property.
- For strongly state-dependent  $M(t,y)$ , set `MvPattern` to a sparse matrix `S` with  $S(i, j) = 1$  if for any  $k$ , the  $(i, k)$  component of  $M(t,y)$  depends on component  $j$  of  $y$ , and 0 otherwise.

If the mass matrix  $M$  is singular, then  $M(t,y)y' = f(t,y)$  is a system of differential algebraic equations. DAEs have solutions only when  $y_0$  is consistent, that is, if there is a vector  $yp_0$  such that  $M(t_0,y_0)yp_0 = f(t_0,y_0)$ . The `ode15s` and `ode23t` solvers can solve DAEs of index 1 provided that  $y_0$  is sufficiently close to being consistent. If there is a mass matrix, you can use `odeset` to set the `MassSingular` property to 'yes', 'no', or 'maybe'. The default value of 'maybe' causes the solver to test whether the problem is a DAE. You can provide `yp0` as the value of the `InitialSlope` property. The default is the zero vector. If a problem is a DAE, and  $y_0$  and  $yp_0$  are not consistent, the solver treats them as guesses, attempts to compute consistent values that are close to the guesses, and continues to solve the problem. When solving DAEs, it is very advantageous to formulate the problem so that  $M$  is a diagonal matrix (a semi-explicit DAE).

<b>Solver</b>	<b>Problem Type</b>	<b>Order of Accuracy</b>	<b>When to Use</b>
ode45	Nonstiff	Medium	Most of the time. This should be the first solver you try.
ode23	Nonstiff	Low	For problems with crude error tolerances or for solving moderately stiff problems.

<b>Solver</b>	<b>Problem Type</b>	<b>Order of Accuracy</b>	<b>When to Use</b>
ode113	Nonstiff	Low to high	For problems with stringent error tolerances or for solving computationally intensive problems.
ode15s	Stiff	Low to medium	If ode45 is slow because the problem is stiff.
ode23s	Stiff	Low	If using crude error tolerances to solve stiff systems and the mass matrix is constant.
ode23t	Moderately Stiff	Low	For moderately stiff problems if you need a solution without numerical damping.
ode23tb	Stiff	Low	If using crude error tolerances to solve stiff systems.

The algorithms used in the ODE solvers vary according to order of accuracy [6] and the type of systems (stiff or nonstiff) they are designed to solve. See “Algorithms” on page 1-4726 for more details.

## Options

Different solvers accept different parameters in the options list. For more information, see `odeset` and “Integrator Options” in the MATLAB Mathematics documentation.

Parameters	ode45	ode23	ode113	ode15s	ode23s	ode23t	ode23tb
RelTol, AbsTol, NormControl	√	√	√	√	√	√	√
OutputFcn, OutputSel, Refine, Stats	√	√	√	√	√	√	√
NonNegative	√	√	√	√ *	—	√ *	√ *
Events	√	√	√	√	√	√	√
MaxStep, InitialStep	√	√	√	√	√	√	√
Jacobian, JPattern, Vectorized	—	—	—	√	√	√	√
Mass	√	√	√	√	√	√	√
MStateDependence	√	√	√	√	—	√	√
MvPattern	—	—	—	√	—	√	√
MassSingular	—	—	—	√	—	√	—
InitialSlope	—	—	—	√	—	√	—
MaxOrder, BDF	—	—	—	√	—	—	—

---

**Note** You can use the NonNegative parameter with ode15s, ode23t, and ode23tb only for those problems for which there is no mass matrix.

---

## Examples

### Example 1

An example of a nonstiff system is the system of equations describing the motion of a rigid body without external forces.

$$\begin{aligned}y_1' &= y_2 y_3 & y_1(0) &= 0 \\y_2' &= -y_1 y_3 & y_2(0) &= 1 \\y_3' &= -0.51 y_1 y_2 & y_3(0) &= 1\end{aligned}$$

To simulate this system, create a function `rigid` containing the equations

```
function dy = rigid(t,y)
dy = zeros(3,1); % a column vector
dy(1) = y(2) * y(3);
dy(2) = -y(1) * y(3);
dy(3) = -0.51 * y(1) * y(2);
```

In this example we change the error tolerances using the `odeset` command and solve on a time interval `[0 12]` with an initial condition vector `[0 1 1]` at time 0.

```
options = odeset('RelTol',1e-4,'AbsTol',[1e-4 1e-4 1e-5]);
[T,Y] = ode45(@rigid,[0 12],[0 1 1],options);
```

Plotting the columns of the returned array `Y` versus `T` shows the solution

```
plot(T,Y(:,1),'-',T,Y(:,2),'-.',T,Y(:,3),'-.')
```

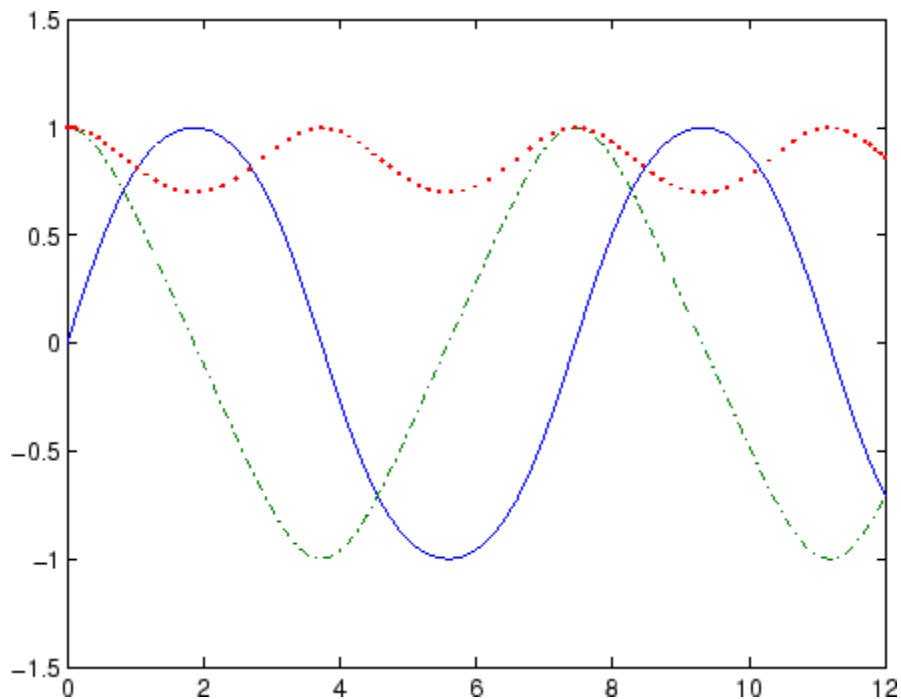

### Example 2

An example of a stiff system is provided by the van der Pol equations in relaxation oscillation. The limit cycle has portions where the solution components change slowly and the problem is quite stiff, alternating with regions of very sharp change where it is not stiff.

$$\begin{aligned} y_1' &= y_2 & y_1(0) &= 2 \\ y_2' &= 1000(1 - y_1^2)y_2 - y_1 & y_2(0) &= 0 \end{aligned}$$

To simulate this system, create a function `vdp1000` containing the equations

```
function dy = vdp1000(t,y)
```

# ode23s

```
dy = zeros(2,1); % a column vector
dy(1) = y(2);
dy(2) = 1000*(1 - y(1)^2)*y(2) - y(1);
```

For this problem, we will use the default relative and absolute tolerances ( $1e-3$  and  $1e-6$ , respectively) and solve on a time interval of  $[0 \ 3000]$  with initial condition vector  $[2 \ 0]$  at time 0.

```
[T,Y] = ode15s(@vdp1000,[0 3000],[2 0]);
```

Plotting the first column of the returned matrix Y versus T shows the solution

```
plot(T,Y(:,1),'-o')
```

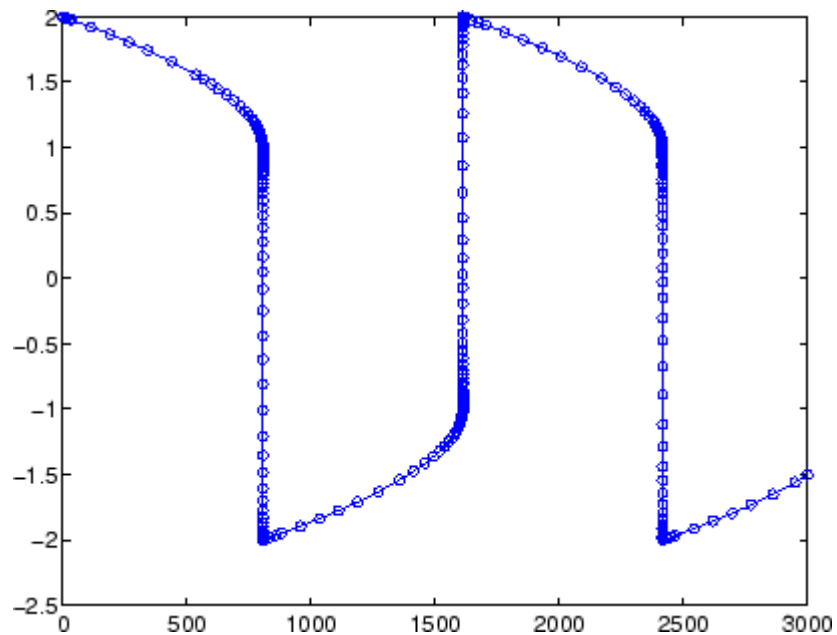

**Example 3**

This example solves an ordinary differential equation with time-dependent terms.

Consider the following ODE, with time-dependent parameters defined only through the set of data points given in two vectors:

$$y'(t) + f(t)y(t) = g(t)$$

The initial condition is  $y(0) = 0$ , where the function  $f(t)$  is defined through the  $n$ -by-1 vectors  $tf$  and  $f$ , and the function  $g(t)$  is defined through the  $m$ -by-1 vectors  $tg$  and  $g$ .

First, define the time-dependent parameters  $f(t)$  and  $g(t)$  as the following:

```
ft = linspace(0,5,25); % Generate t for f
f = ft.^2 - ft - 3; % Generate f(t)
gt = linspace(1,6,25); % Generate t for g
g = 3*sin(gt-0.25); % Generate g(t)
```

Write a function to interpolate the data sets specified above to obtain the value of the time-dependent terms at the specified time:

```
function dydt = myode(t,y,ft,f,gt,g)
f = interp1(ft,f,t); % Interpolate the data set (ft,f) at time t
g = interp1(gt,g,t); % Interpolate the data set (gt,g) at time t
dydt = -f.*y + g; % Evaluate ODE at time t
```

Call the derivative function `myode.m` within the MATLAB `ode45` function specifying time as the first input argument :

```
Tspan = [1 5]; % Solve from t=1 to t=5
IC = 1; % y(t=0) = 1
[T Y] = ode45(@(t,y) myode(t,y,ft,f,gt,g),Tspan,IC); % Solve ODE
```

Plot the solution  $y(t)$  as a function of time:

```
plot(T, Y);
```

```
title('Plot of y as a function of time');
xlabel('Time'); ylabel('Y(t)');
```

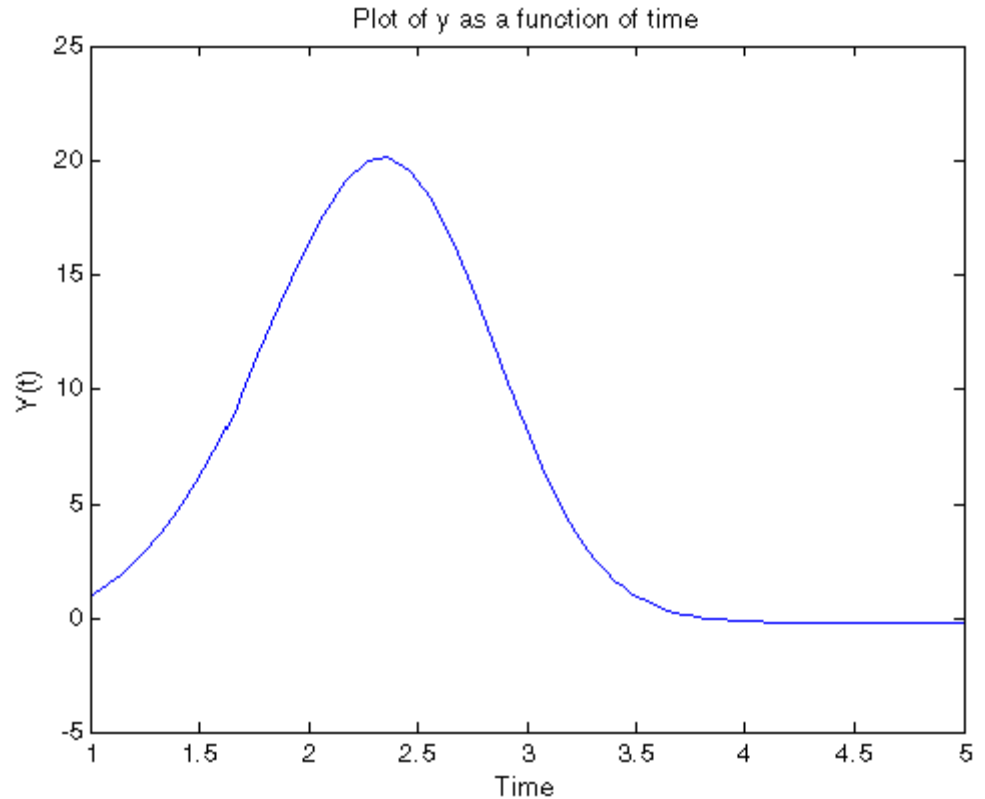

## Algorithms

ode45 is based on an explicit Runge-Kutta (4,5) formula, the Dormand-Prince pair. It is a *one-step* solver – in computing  $y(t_n)$ , it needs only the solution at the immediately preceding time point,  $y(t_{n-1})$ . In general, ode45 is the best function to apply as a *first try* for most problems. [3]

ode23 is an implementation of an explicit Runge-Kutta (2,3) pair of Bogacki and Shampine. It may be more efficient than ode45 at crude



tolerances and in the presence of moderate stiffness. Like `ode45`, `ode23` is a one-step solver. [2]

`ode113` is a variable order Adams-Bashforth-Moulton PECE solver. It may be more efficient than `ode45` at stringent tolerances and when the ODE file function is particularly expensive to evaluate. `ode113` is a *multistep* solver — it normally needs the solutions at several preceding time points to compute the current solution. [7]

The above algorithms are intended to solve nonstiff systems. If they appear to be unduly slow, try using one of the stiff solvers below.

`ode15s` is a variable order solver based on the numerical differentiation formulas (NDFs). Optionally, it uses the backward differentiation formulas (BDFs, also known as Gear’s method) that are usually less efficient. Like `ode113`, `ode15s` is a multistep solver. Try `ode15s` when `ode45` fails, or is very inefficient, and you suspect that the problem is stiff, or when solving a differential-algebraic problem. [9], [10]

`ode23s` is based on a modified Rosenbrock formula of order 2. Because it is a one-step solver, it may be more efficient than `ode15s` at crude tolerances. It can solve some kinds of stiff problems for which `ode15s` is not effective. [9]

`ode23t` is an implementation of the trapezoidal rule using a “free” interpolant. Use this solver if the problem is only moderately stiff and you need a solution without numerical damping. `ode23t` can solve DAEs. [10]

`ode23tb` is an implementation of TR-BDF2, an implicit Runge-Kutta formula with a first stage that is a trapezoidal rule step and a second stage that is a backward differentiation formula of order two. By construction, the same iteration matrix is used in evaluating both stages. Like `ode23s`, this solver may be more efficient than `ode15s` at crude tolerances. [8], [1]

## References

[1] Bank, R. E., W. C. Coughran, Jr., W. Fichtner, E. Grosse, D. Rose, and R. Smith, “Transient Simulation of Silicon Devices and Circuits,” *IEEE Trans. CAD*, 4 (1985), pp. 436–451.

- [2] Bogacki, P. and L. F. Shampine, “A 3(2) pair of Runge-Kutta formulas,” *Appl. Math. Letters*, Vol. 2, 1989, pp. 321–325.
- [3] Dormand, J. R. and P. J. Prince, “A family of embedded Runge-Kutta formulae,” *J. Comp. Appl. Math.*, Vol. 6, 1980, pp. 19–26.
- [4] Forsythe, G. , M. Malcolm, and C. Moler, *Computer Methods for Mathematical Computations*, Prentice-Hall, New Jersey, 1977.
- [5] Kahaner, D. , C. Moler, and S. Nash, *Numerical Methods and Software*, Prentice-Hall, New Jersey, 1989.
- [6] Shampine, L. F. , *Numerical Solution of Ordinary Differential Equations*, Chapman & Hall, New York, 1994.
- [7] Shampine, L. F. and M. K. Gordon, *Computer Solution of Ordinary Differential Equations: the Initial Value Problem*, W. H. Freeman, San Francisco, 1975.
- [8] Shampine, L. F. and M. E. Hosea, “Analysis and Implementation of TR-BDF2,” *Applied Numerical Mathematics* 20, 1996.
- [9] Shampine, L. F. and M. W. Reichelt, “The MATLAB ODE Suite,” *SIAM Journal on Scientific Computing*, Vol. 18, 1997, pp. 1–22.
- [10] Shampine, L. F., M. W. Reichelt, and J.A. Kierzenka, “Solving Index-1 DAEs in MATLAB and Simulink,” *SIAM Review*, Vol. 41, 1999, pp. 538–552.

## See Also

`deval` | `ode15i` | `odeget` | `odeset` | `function_handle`

**Purpose**

Solve moderately stiff ODEs and DAEs; trapezoidal rule

**Syntax**

```
[T,Y] = solver(odefun,tspan,y0)
[T,Y] = solver(odefun,tspan,y0,options)
[T,Y,TE,YE,IE] = solver(odefun,tspan,y0,options)
sol = solver(odefun,[t0 tf],y0...)
```

This page contains an overview of the solver functions: `ode23`, `ode45`, `ode113`, `ode15s`, `ode23s`, `ode23t`, and `ode23tb`. You can call any of these solvers by substituting the placeholder, `solver`, with any of the function names.

**Arguments**

The following table describes the input arguments to the solvers.

<code>odefun</code>	A function handle that evaluates the right side of the differential equations. All solvers solve systems of equations in the form $y' = f(t,y)$ or problems that involve a mass matrix, $M(t,y)y' = f(t,y)$ . The <code>ode23s</code> solver can solve only equations with constant mass matrices. <code>ode15s</code> and <code>ode23t</code> can solve problems with a mass matrix that is singular, i.e., differential-algebraic equations (DAEs).
<code>tspan</code>	A vector specifying the interval of integration, <code>[t0,tf]</code> . The solver imposes the initial conditions at <code>tspan(1)</code> , and integrates from <code>tspan(1)</code> to <code>tspan(end)</code> . To obtain solutions at specific times (all increasing or all decreasing), use <code>tspan = [t0,t1,...,tf]</code> .  For <code>tspan</code> vectors with two elements <code>[t0 tf]</code> , the solver returns the solution evaluated at every integration step. For <code>tspan</code> vectors with more than two elements, the solver returns solutions evaluated at the given time points. The time values must be in order, either increasing or decreasing.

Specifying `tspan` with more than two elements does not affect the internal time steps that the solver uses to traverse the interval from `tspan(1)` to `tspan(end)`. All solvers in the ODE suite obtain output values by means of continuous extensions of the basic formulas. Although a solver does not necessarily step precisely to a time point specified in `tspan`, the solutions produced at the specified time points are of the same order of accuracy as the solutions computed at the internal time points.

Specifying `tspan` with more than two elements has little effect on the efficiency of computation, but for large systems, affects memory management.

`y0`

A vector of initial conditions.

`options`

Structure of optional parameters that change the default integration properties. This is the fourth input argument.

```
[t,y] = solver(odefun,tspan,y0,options)
```

You can create options using the `odeset` function. See `odeset` for details.

The following table lists the output arguments for the solvers.

T	Column vector of time points.
Y	Solution array. Each row in Y corresponds to the solution at a time returned in the corresponding row of T.
TE	The time at which an event occurs.
YE	The solution at the time of the event.

IE	The index <i>i</i> of the event function that vanishes.
sol	Structure to evaluate the solution.

## Description

$[T, Y] = \text{solver}(\text{odefun}, \text{tspan}, y_0)$  with  $\text{tspan} = [t_0 \text{ } t_f]$  integrates the system of differential equations  $y' = f(t, y)$  from time  $t_0$  to  $t_f$  with initial conditions  $y_0$ . The first input argument, `odefun`, is a function handle. The function,  $f = \text{odefun}(t, y)$ , for a scalar  $t$  and a column vector  $y$ , must return a column vector  $f$  corresponding to  $f(t, y)$ . Each row in the solution array  $Y$  corresponds to a time returned in column vector  $T$ . To obtain solutions at the specific times  $t_0, t_1, \dots, t_f$  (all increasing or all decreasing), use  $\text{tspan} = [t_0, t_1, \dots, t_f]$ .

“Parameterizing Functions” explains how to provide additional parameters to the function `fun`, if necessary.

$[T, Y] = \text{solver}(\text{odefun}, \text{tspan}, y_0, \text{options})$  solves as above with default integration parameters replaced by property values specified in `options`, an argument created with the `odeset` function. Commonly used properties include a scalar relative error tolerance `RelTol` ( $1e-3$  by default) and a vector of absolute error tolerances `AbsTol` (all components are  $1e-6$  by default). If certain components of the solution must be nonnegative, use the `odeset` function to set the `NonNegative` property to the indices of these components. See `odeset` for details.

$[T, Y, TE, YE, IE] = \text{solver}(\text{odefun}, \text{tspan}, y_0, \text{options})$  solves as above while also finding where functions of  $(t, y)$ , called event functions, are zero. For each event function, you specify whether the integration is to terminate at a zero and whether the direction of the zero crossing matters. Do this by setting the 'Events' property to a function, e.g., `events` or `@events`, and creating a function  $[\text{value}, \text{isterminal}, \text{direction}] = \text{events}(t, y)$ . For the  $i$ th event function in `events`,

- `value(i)` is the value of the function.
- `isterminal(i) = 1`, if the integration is to terminate at a zero of this event function and 0 otherwise.

- `direction(i)` = 0 if all zeros are to be computed (the default), +1 if only the zeros where the event function increases, and -1 if only the zeros where the event function decreases.

Corresponding entries in `TE`, `YE`, and `IE` return, respectively, the time at which an event occurs, the solution at the time of the event, and the index `i` of the event function that vanishes.

`sol = solver(odefun,[t0 tf],y0...)` returns a structure that you can use with `deval` to evaluate the solution at any point on the interval `[t0,tf]`. You must pass `odefun` as a function handle. The structure `sol` always includes these fields:

<code>sol.x</code>	Steps chosen by the solver.
<code>sol.y</code>	Each column <code>sol.y(:,i)</code> contains the solution at <code>sol.x(i)</code> .
<code>sol.solver</code>	Solver name.

If you specify the `Events` option and events are detected, `sol` also includes these fields:

<code>sol.xe</code>	Points at which events, if any, occurred. <code>sol.xe(end)</code> contains the exact point of a terminal event, if any.
<code>sol.ye</code>	Solutions that correspond to events in <code>sol.xe</code> .
<code>sol.ie</code>	Indices into the vector returned by the function specified in the <code>Events</code> option. The values indicate which event the solver detected.

If you specify an output function as the value of the `OutputFcn` property, the solver calls it with the computed solution after each time step. Four output functions are provided: `odeplot`, `odephas2`, `odephas3`, `odeprint`. When you call the solver with no output arguments, it calls the default `odeplot` to plot the solution as it is computed. `odephas2` and `odephas3` produce two- and three-dimensional phase plane plots, respectively. `odeprint` displays the solution components on the screen.

By default, the ODE solver passes all components of the solution to the output function. You can pass only specific components by providing a vector of indices as the value of the `OutputSel` property. For example, if you call the solver with no output arguments and set the value of `OutputSel` to `[1,3]`, the solver plots solution components 1 and 3 as they are computed.

For the stiff solvers `ode15s`, `ode23s`, `ode23t`, and `ode23tb`, the Jacobian matrix  $\partial f/\partial y$  is critical to reliability and efficiency. Use `odeset` to set `Jacobian` to `@FJAC` if `FJAC(T,Y)` returns the Jacobian  $\partial f/\partial y$  or to the matrix  $\partial f/\partial y$  if the Jacobian is constant. If the `Jacobian` property is not set (the default),  $\partial f/\partial y$  is approximated by finite differences. Set the `Vectorized` property 'on' if the ODE function is coded so that `odefun(T,[Y1,Y2 ...])` returns `[odefun(T,Y1),odefun(T,Y2) ...]`. If  $\partial f/\partial y$  is a sparse matrix, set the `JPattern` property to the sparsity pattern of  $\partial f/\partial y$ , i.e., a sparse matrix `S` with `S(i,j) = 1` if the *i*th component of  $f(t,y)$  depends on the *j*th component of  $y$ , and 0 otherwise.

The solvers of the ODE suite can solve problems of the form  $M(t,y)y' = f(t,y)$ , with time- and state-dependent mass matrix  $M$ . (The `ode23s` solver can solve only equations with constant mass matrices.) If a problem has a mass matrix, create a function `M = MASS(t,y)` that returns the value of the mass matrix, and use `odeset` to set the `Mass` property to `@MASS`. If the mass matrix is constant, the matrix should be used as the value of the `Mass` property. Problems with state-dependent mass matrices are more difficult:

- If the mass matrix does not depend on the state variable  $y$  and the function `MASS` is to be called with one input argument, `t`, set the `MStateDependence` property to 'none'.
- If the mass matrix depends weakly on  $y$ , set `MStateDependence` to 'weak' (the default); otherwise, set it to 'strong'. In either case, the function `MASS` is called with the two arguments `(t,y)`.

If there are many differential equations, it is important to exploit sparsity:

- Return a sparse  $M(t,y)$ .

- Supply the sparsity pattern of  $\partial f/\partial y$  using the `JPattern` property or a sparse  $\partial f/\partial y$  using the `Jacobian` property.
- For strongly state-dependent  $M(t,y)$ , set `MVPattern` to a sparse matrix `S` with `S(i,j) = 1` if for any `k`, the `(i,k)` component of  $M(t,y)$  depends on component `j` of `y`, and `0` otherwise.

If the mass matrix  $M$  is singular, then  $M(t,y)y' = f(t,y)$  is a system of differential algebraic equations. DAEs have solutions only when  $y_0$  is consistent, that is, if there is a vector  $yp_0$  such that  $M(t_0,y_0)yp_0 = f(t_0,y_0)$ . The `ode15s` and `ode23t` solvers can solve DAEs of index 1 provided that  $y_0$  is sufficiently close to being consistent. If there is a mass matrix, you can use `odeset` to set the `MassSingular` property to 'yes', 'no', or 'maybe'. The default value of 'maybe' causes the solver to test whether the problem is a DAE. You can provide `yp0` as the value of the `InitialSlope` property. The default is the zero vector. If a problem is a DAE, and  $y_0$  and  $yp_0$  are not consistent, the solver treats them as guesses, attempts to compute consistent values that are close to the guesses, and continues to solve the problem. When solving DAEs, it is very advantageous to formulate the problem so that  $M$  is a diagonal matrix (a semi-explicit DAE).

Solver	Problem Type	Order of Accuracy	When to Use
ode45	Nonstiff	Medium	Most of the time. This should be the first solver you try.
ode23	Nonstiff	Low	For problems with crude error tolerances or for solving moderately stiff problems.



<b>Solver</b>	<b>Problem Type</b>	<b>Order of Accuracy</b>	<b>When to Use</b>
ode113	Nonstiff	Low to high	For problems with stringent error tolerances or for solving computationally intensive problems.
ode15s	Stiff	Low to medium	If ode45 is slow because the problem is stiff.
ode23s	Stiff	Low	If using crude error tolerances to solve stiff systems and the mass matrix is constant.
ode23t	Moderately Stiff	Low	For moderately stiff problems if you need a solution without numerical damping.
ode23tb	Stiff	Low	If using crude error tolerances to solve stiff systems.

The algorithms used in the ODE solvers vary according to order of accuracy [6] and the type of systems (stiff or nonstiff) they are designed to solve. See “Algorithms” on page 1-4741 for more details.

## Options

Different solvers accept different parameters in the options list. For more information, see `odeset` and “Integrator Options” in the MATLAB Mathematics documentation.

Parameters	ode45	ode23	ode113	ode15s	ode23s	ode23t	ode23tb
RelTol, AbsTol, NormControl	√	√	√	√	√	√	√
OutputFcn, OutputSel, Refine, Stats	√	√	√	√	√	√	√
NonNegative	√	√	√	√ *	—	√ *	√ *
Events	√	√	√	√	√	√	√
MaxStep, InitialStep	√	√	√	√	√	√	√
Jacobian, JPattern, Vectorized	—	—	—	√	√	√	√
Mass	√	√	√	√	√	√	√
MStateDependence	√	√	√	√	—	√	√
MvPattern	—	—	—	√	—	√	√
MassSingular	—	—	—	√	—	√	—
InitialSlope	—	—	—	√	—	√	—
MaxOrder, BDF	—	—	—	√	—	—	—

---

**Note** You can use the NonNegative parameter with ode15s, ode23t, and ode23tb only for those problems for which there is no mass matrix.

---

## Examples

### Example 1

An example of a nonstiff system is the system of equations describing the motion of a rigid body without external forces.

$$\begin{aligned}y_1' &= y_2 y_3 & y_1(0) &= 0 \\y_2' &= -y_1 y_3 & y_2(0) &= 1 \\y_3' &= -0.51 y_1 y_2 & y_3(0) &= 1\end{aligned}$$

To simulate this system, create a function `rigid` containing the equations

```
function dy = rigid(t,y)
dy = zeros(3,1); % a column vector
dy(1) = y(2) * y(3);
dy(2) = -y(1) * y(3);
dy(3) = -0.51 * y(1) * y(2);
```

In this example we change the error tolerances using the `odeset` command and solve on a time interval `[0 12]` with an initial condition vector `[0 1 1]` at time 0.

```
options = odeset('RelTol',1e-4,'AbsTol',[1e-4 1e-4 1e-5]);
[T,Y] = ode45(@rigid,[0 12],[0 1 1],options);
```

Plotting the columns of the returned array `Y` versus `T` shows the solution

```
plot(T,Y(:,1),'-',T,Y(:,2),'-.',T,Y(:,3),'.')
```

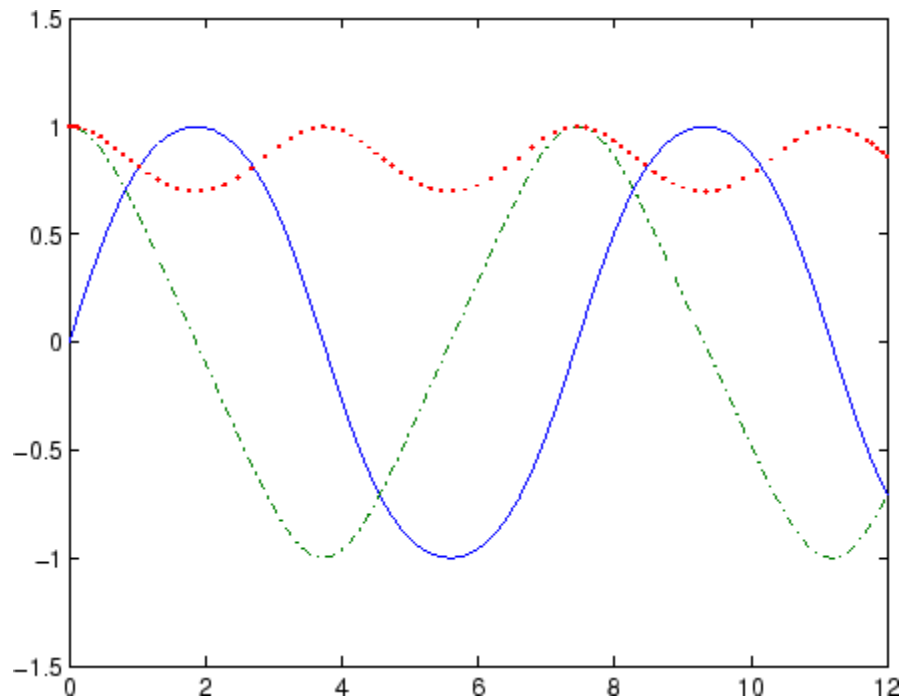

### Example 2

An example of a stiff system is provided by the van der Pol equations in relaxation oscillation. The limit cycle has portions where the solution components change slowly and the problem is quite stiff, alternating with regions of very sharp change where it is not stiff.

$$\begin{aligned}y_1' &= y_2 & y_1(0) &= 2 \\y_2' &= 1000(1 - y_1^2)y_2 - y_1 & y_2(0) &= 0\end{aligned}$$

To simulate this system, create a function `vdp1000` containing the equations

```
function dy = vdp1000(t,y)
```

```
dy = zeros(2,1); % a column vector
dy(1) = y(2);
dy(2) = 1000*(1 - y(1)^2)*y(2) - y(1);
```

For this problem, we will use the default relative and absolute tolerances ( $1e-3$  and  $1e-6$ , respectively) and solve on a time interval of  $[0 \ 3000]$  with initial condition vector  $[2 \ 0]$  at time 0.

```
[T,Y] = ode15s(@vdp1000,[0 3000],[2 0]);
```

Plotting the first column of the returned matrix Y versus T shows the solution

```
plot(T,Y(:,1),'-o')
```

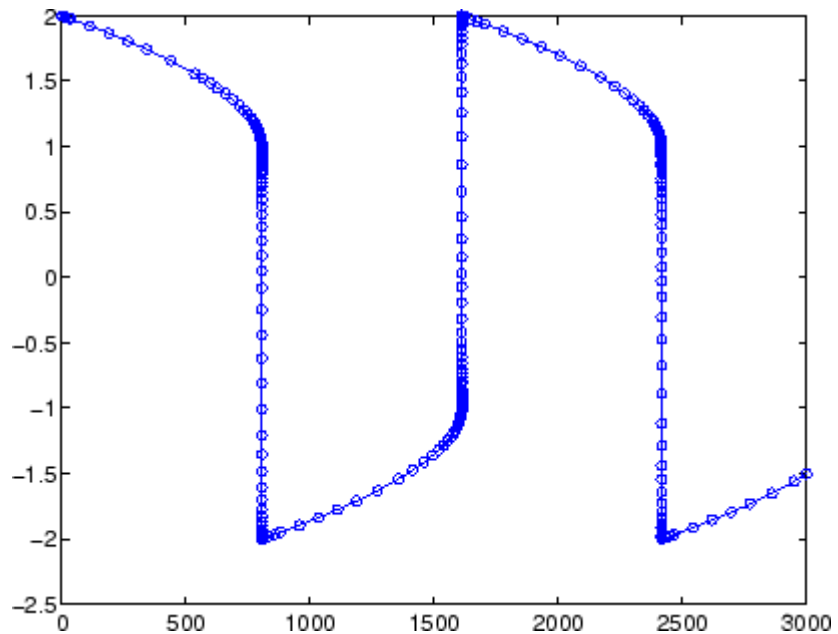

## Example 3

This example solves an ordinary differential equation with time-dependent terms.

Consider the following ODE, with time-dependent parameters defined only through the set of data points given in two vectors:

$$y'(t) + f(t)y(t) = g(t)$$

The initial condition is  $y(0) = 0$ , where the function  $f(t)$  is defined through the  $n$ -by-1 vectors  $tf$  and  $f$ , and the function  $g(t)$  is defined through the  $m$ -by-1 vectors  $tg$  and  $g$ .

First, define the time-dependent parameters  $f(t)$  and  $g(t)$  as the following:

```
ft = linspace(0,5,25); % Generate t for f
f = ft.^2 - ft - 3; % Generate f(t)
gt = linspace(1,6,25); % Generate t for g
g = 3*sin(gt-0.25); % Generate g(t)
```

Write a function to interpolate the data sets specified above to obtain the value of the time-dependent terms at the specified time:

```
function dydt = myode(t,y,ft,f,gt,g)
f = interp1(ft,f,t); % Interpolate the data set (ft,f) at time t
g = interp1(gt,g,t); % Interpolate the data set (gt,g) at time t
dydt = -f.*y + g; % Evaluate ODE at time t
```

Call the derivative function `myode.m` within the MATLAB `ode45` function specifying time as the first input argument :

```
Tspan = [1 5]; % Solve from t=1 to t=5
IC = 1; % y(t=0) = 1
[T Y] = ode45(@(t,y) myode(t,y,ft,f,gt,g),Tspan,IC); % Solve ODE
```

Plot the solution  $y(t)$  as a function of time:

```
plot(T, Y);
```

```
title('Plot of y as a function of time');
xlabel('Time'); ylabel('Y(t)');
```

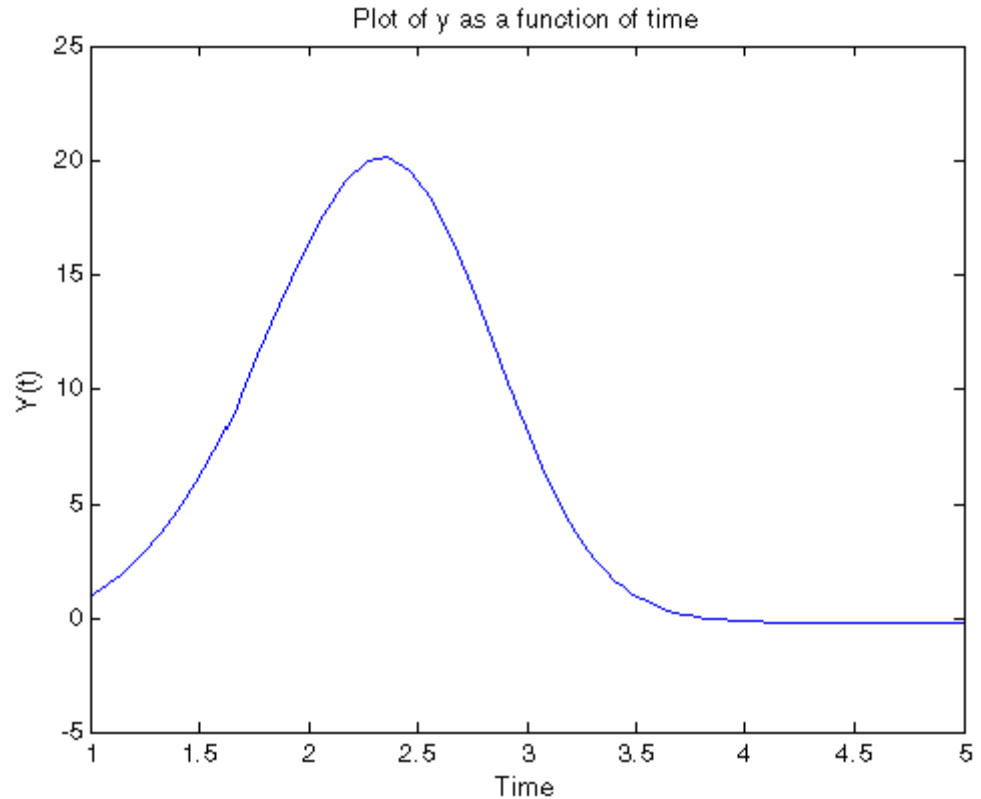

## Algorithms

`ode45` is based on an explicit Runge-Kutta (4,5) formula, the Dormand-Prince pair. It is a *one-step* solver – in computing  $y(t_n)$ , it needs only the solution at the immediately preceding time point,  $y(t_{n-1})$ . In general, `ode45` is the best function to apply as a *first try* for most problems. [3]

`ode23` is an implementation of an explicit Runge-Kutta (2,3) pair of Bogacki and Shampine. It may be more efficient than `ode45` at crude

tolerances and in the presence of moderate stiffness. Like `ode45`, `ode23` is a one-step solver. [2]

`ode113` is a variable order Adams-Bashforth-Moulton PECE solver. It may be more efficient than `ode45` at stringent tolerances and when the ODE file function is particularly expensive to evaluate. `ode113` is a *multistep* solver — it normally needs the solutions at several preceding time points to compute the current solution. [7]

The above algorithms are intended to solve nonstiff systems. If they appear to be unduly slow, try using one of the stiff solvers below.

`ode15s` is a variable order solver based on the numerical differentiation formulas (NDFs). Optionally, it uses the backward differentiation formulas (BDFs, also known as Gear's method) that are usually less efficient. Like `ode113`, `ode15s` is a multistep solver. Try `ode15s` when `ode45` fails, or is very inefficient, and you suspect that the problem is stiff, or when solving a differential-algebraic problem. [9], [10]

`ode23s` is based on a modified Rosenbrock formula of order 2. Because it is a one-step solver, it may be more efficient than `ode15s` at crude tolerances. It can solve some kinds of stiff problems for which `ode15s` is not effective. [9]

`ode23t` is an implementation of the trapezoidal rule using a “free” interpolant. Use this solver if the problem is only moderately stiff and you need a solution without numerical damping. `ode23t` can solve DAEs. [10]

`ode23tb` is an implementation of TR-BDF2, an implicit Runge-Kutta formula with a first stage that is a trapezoidal rule step and a second stage that is a backward differentiation formula of order two. By construction, the same iteration matrix is used in evaluating both stages. Like `ode23s`, this solver may be more efficient than `ode15s` at crude tolerances. [8], [1]

## References

[1] Bank, R. E., W. C. Coughran, Jr., W. Fichtner, E. Grosse, D. Rose, and R. Smith, “Transient Simulation of Silicon Devices and Circuits,” *IEEE Trans. CAD*, 4 (1985), pp. 436–451.



- [2] Bogacki, P. and L. F. Shampine, “A 3(2) pair of Runge-Kutta formulas,” *Appl. Math. Letters*, Vol. 2, 1989, pp. 321–325.
- [3] Dormand, J. R. and P. J. Prince, “A family of embedded Runge-Kutta formulae,” *J. Comp. Appl. Math.*, Vol. 6, 1980, pp. 19–26.
- [4] Forsythe, G. , M. Malcolm, and C. Moler, *Computer Methods for Mathematical Computations*, Prentice-Hall, New Jersey, 1977.
- [5] Kahaner, D. , C. Moler, and S. Nash, *Numerical Methods and Software*, Prentice-Hall, New Jersey, 1989.
- [6] Shampine, L. F. , *Numerical Solution of Ordinary Differential Equations*, Chapman & Hall, New York, 1994.
- [7] Shampine, L. F. and M. K. Gordon, *Computer Solution of Ordinary Differential Equations: the Initial Value Problem*, W. H. Freeman, San Francisco, 1975.
- [8] Shampine, L. F. and M. E. Hosea, “Analysis and Implementation of TR-BDF2,” *Applied Numerical Mathematics* 20, 1996.
- [9] Shampine, L. F. and M. W. Reichelt, “The MATLAB ODE Suite,” *SIAM Journal on Scientific Computing*, Vol. 18, 1997, pp. 1–22.
- [10] Shampine, L. F., M. W. Reichelt, and J.A. Kierzenka, “Solving Index-1 DAEs in MATLAB and Simulink,” *SIAM Review*, Vol. 41, 1999, pp. 538–552.

**See Also**

deval | ode15i | odeget | odeset | function\_handle

**Purpose** Solve stiff differential equations; low order method

**Syntax**

```
[T,Y] = solver(odefun,tspan,y0)
[T,Y] = solver(odefun,tspan,y0,options)
[T,Y,TE,YE,IE] = solver(odefun,tspan,y0,options)
sol = solver(odefun,[t0 tf],y0...)
```

This page contains an overview of the solver functions: `ode23`, `ode45`, `ode113`, `ode15s`, `ode23s`, `ode23t`, and `ode23tb`. You can call any of these solvers by substituting the placeholder, `solver`, with any of the function names.

**Arguments** The following table describes the input arguments to the solvers.

<code>odefun</code>	A function handle that evaluates the right side of the differential equations. All solvers solve systems of equations in the form $y' = f(t,y)$ or problems that involve a mass matrix, $M(t,y)y' = f(t,y)$ . The <code>ode23s</code> solver can solve only equations with constant mass matrices. <code>ode15s</code> and <code>ode23t</code> can solve problems with a mass matrix that is singular, i.e., differential-algebraic equations (DAEs).
<code>tspan</code>	A vector specifying the interval of integration, <code>[t0,tf]</code> . The solver imposes the initial conditions at <code>tspan(1)</code> , and integrates from <code>tspan(1)</code> to <code>tspan(end)</code> . To obtain solutions at specific times (all increasing or all decreasing), use <code>tspan = [t0,t1,...,tf]</code> .  For <code>tspan</code> vectors with two elements <code>[t0 tf]</code> , the solver returns the solution evaluated at every integration step. For <code>tspan</code> vectors with more than two elements, the solver returns solutions evaluated at the given time points. The time values must be in order, either increasing or decreasing.

Specifying `tspan` with more than two elements does not affect the internal time steps that the solver uses to traverse the interval from `tspan(1)` to `tspan(end)`. All solvers in the ODE suite obtain output values by means of continuous extensions of the basic formulas. Although a solver does not necessarily step precisely to a time point specified in `tspan`, the solutions produced at the specified time points are of the same order of accuracy as the solutions computed at the internal time points.

Specifying `tspan` with more than two elements has little effect on the efficiency of computation, but for large systems, affects memory management.

`y0`

A vector of initial conditions.

`options`

Structure of optional parameters that change the default integration properties. This is the fourth input argument.

```
[t,y] = solver(odefun,tspan,y0,options)
```

You can create options using the `odeset` function. See `odeset` for details.

The following table lists the output arguments for the solvers.

<code>T</code>	Column vector of time points.
<code>Y</code>	Solution array. Each row in <code>Y</code> corresponds to the solution at a time returned in the corresponding row of <code>T</code> .
<code>TE</code>	The time at which an event occurs.
<code>YE</code>	The solution at the time of the event.

IE	The index <i>i</i> of the event function that vanishes.
sol	Structure to evaluate the solution.

## Description

$[T, Y] = \text{solver}(\text{odefun}, \text{tspan}, y_0)$  with  $\text{tspan} = [t_0 \text{ } t_f]$  integrates the system of differential equations  $y' = f(t, y)$  from time  $t_0$  to  $t_f$  with initial conditions  $y_0$ . The first input argument, `odefun`, is a function handle. The function,  $f = \text{odefun}(t, y)$ , for a scalar  $t$  and a column vector  $y$ , must return a column vector  $f$  corresponding to  $f(t, y)$ . Each row in the solution array  $Y$  corresponds to a time returned in column vector  $T$ . To obtain solutions at the specific times  $t_0, t_1, \dots, t_f$  (all increasing or all decreasing), use  $\text{tspan} = [t_0, t_1, \dots, t_f]$ .

“Parameterizing Functions” explains how to provide additional parameters to the function `fun`, if necessary.

$[T, Y] = \text{solver}(\text{odefun}, \text{tspan}, y_0, \text{options})$  solves as above with default integration parameters replaced by property values specified in `options`, an argument created with the `odeset` function. Commonly used properties include a scalar relative error tolerance `RelTol` ( $1e-3$  by default) and a vector of absolute error tolerances `AbsTol` (all components are  $1e-6$  by default). If certain components of the solution must be nonnegative, use the `odeset` function to set the `NonNegative` property to the indices of these components. See `odeset` for details.

$[T, Y, TE, YE, IE] = \text{solver}(\text{odefun}, \text{tspan}, y_0, \text{options})$  solves as above while also finding where functions of  $(t, y)$ , called event functions, are zero. For each event function, you specify whether the integration is to terminate at a zero and whether the direction of the zero crossing matters. Do this by setting the 'Events' property to a function, e.g., `events` or `@events`, and creating a function  $[\text{value}, \text{isterminal}, \text{direction}] = \text{events}(t, y)$ . For the  $i$ th event function in `events`,

- `value(i)` is the value of the function.
- `isterminal(i) = 1`, if the integration is to terminate at a zero of this event function and 0 otherwise.

- `direction(i) = 0` if all zeros are to be computed (the default), `+1` if only the zeros where the event function increases, and `-1` if only the zeros where the event function decreases.

Corresponding entries in `TE`, `YE`, and `IE` return, respectively, the time at which an event occurs, the solution at the time of the event, and the index `i` of the event function that vanishes.

`sol = solver(odefun,[t0 tf],y0...)` returns a structure that you can use with `deval` to evaluate the solution at any point on the interval `[t0,tf]`. You must pass `odefun` as a function handle. The structure `sol` always includes these fields:

<code>sol.x</code>	Steps chosen by the solver.
<code>sol.y</code>	Each column <code>sol.y(:,i)</code> contains the solution at <code>sol.x(i)</code> .
<code>sol.solver</code>	Solver name.

If you specify the `Events` option and events are detected, `sol` also includes these fields:

<code>sol.xe</code>	Points at which events, if any, occurred. <code>sol.xe(end)</code> contains the exact point of a terminal event, if any.
<code>sol.ye</code>	Solutions that correspond to events in <code>sol.xe</code> .
<code>sol.ie</code>	Indices into the vector returned by the function specified in the <code>Events</code> option. The values indicate which event the solver detected.

If you specify an output function as the value of the `OutputFcn` property, the solver calls it with the computed solution after each time step. Four output functions are provided: `odeplot`, `odephas2`, `odephas3`, `odeprint`. When you call the solver with no output arguments, it calls the default `odeplot` to plot the solution as it is computed. `odephas2` and `odephas3` produce two- and three-dimensional phase plane plots, respectively. `odeprint` displays the solution components on the screen.

By default, the ODE solver passes all components of the solution to the output function. You can pass only specific components by providing a vector of indices as the value of the `OutputSel` property. For example, if you call the solver with no output arguments and set the value of `OutputSel` to `[1,3]`, the solver plots solution components 1 and 3 as they are computed.

For the stiff solvers `ode15s`, `ode23s`, `ode23t`, and `ode23tb`, the Jacobian matrix  $\partial f/\partial y$  is critical to reliability and efficiency. Use `odeset` to set `Jacobian` to `@FJAC` if `FJAC(T,Y)` returns the Jacobian  $\partial f/\partial y$  or to the matrix  $\partial f/\partial y$  if the Jacobian is constant. If the `Jacobian` property is not set (the default),  $\partial f/\partial y$  is approximated by finite differences. Set the `Vectorized` property 'on' if the ODE function is coded so that `odefun(T,[Y1,Y2 ...])` returns `[odefun(T,Y1),odefun(T,Y2) ...]`. If  $\partial f/\partial y$  is a sparse matrix, set the `JPattern` property to the sparsity pattern of  $\partial f/\partial y$ , i.e., a sparse matrix `S` with `S(i,j) = 1` if the *i*th component of  $f(t,y)$  depends on the *j*th component of  $y$ , and 0 otherwise.

The solvers of the ODE suite can solve problems of the form  $M(t,y)y' = f(t,y)$ , with time- and state-dependent mass matrix  $M$ . (The `ode23s` solver can solve only equations with constant mass matrices.) If a problem has a mass matrix, create a function `M = MASS(t,y)` that returns the value of the mass matrix, and use `odeset` to set the `Mass` property to `@MASS`. If the mass matrix is constant, the matrix should be used as the value of the `Mass` property. Problems with state-dependent mass matrices are more difficult:

- If the mass matrix does not depend on the state variable  $y$  and the function `MASS` is to be called with one input argument, `t`, set the `MStateDependence` property to 'none'.
- If the mass matrix depends weakly on  $y$ , set `MStateDependence` to 'weak' (the default); otherwise, set it to 'strong'. In either case, the function `MASS` is called with the two arguments `(t,y)`.

If there are many differential equations, it is important to exploit sparsity:

- Return a sparse  $M(t,y)$ .

- Supply the sparsity pattern of  $\partial f/\partial y$  using the `JPattern` property or a sparse  $\partial f/\partial y$  using the `Jacobian` property.
- For strongly state-dependent  $M(t,y)$ , set `MvPattern` to a sparse matrix `S` with  $S(i, j) = 1$  if for any  $k$ , the  $(i, k)$  component of  $M(t,y)$  depends on component  $j$  of  $y$ , and 0 otherwise.

If the mass matrix  $M$  is singular, then  $M(t,y)y' = f(t,y)$  is a system of differential algebraic equations. DAEs have solutions only when  $y_0$  is consistent, that is, if there is a vector  $yp_0$  such that  $M(t_0,y_0)yp_0 = f(t_0,y_0)$ . The `ode15s` and `ode23t` solvers can solve DAEs of index 1 provided that  $y_0$  is sufficiently close to being consistent. If there is a mass matrix, you can use `odeset` to set the `MassSingular` property to 'yes', 'no', or 'maybe'. The default value of 'maybe' causes the solver to test whether the problem is a DAE. You can provide `yp0` as the value of the `InitialSlope` property. The default is the zero vector. If a problem is a DAE, and  $y_0$  and  $yp_0$  are not consistent, the solver treats them as guesses, attempts to compute consistent values that are close to the guesses, and continues to solve the problem. When solving DAEs, it is very advantageous to formulate the problem so that  $M$  is a diagonal matrix (a semi-explicit DAE).

<b>Solver</b>	<b>Problem Type</b>	<b>Order of Accuracy</b>	<b>When to Use</b>
ode45	Nonstiff	Medium	Most of the time. This should be the first solver you try.
ode23	Nonstiff	Low	For problems with crude error tolerances or for solving moderately stiff problems.

<b>Solver</b>	<b>Problem Type</b>	<b>Order of Accuracy</b>	<b>When to Use</b>
ode113	Nonstiff	Low to high	For problems with stringent error tolerances or for solving computationally intensive problems.
ode15s	Stiff	Low to medium	If ode45 is slow because the problem is stiff.
ode23s	Stiff	Low	If using crude error tolerances to solve stiff systems and the mass matrix is constant.
ode23t	Moderately Stiff	Low	For moderately stiff problems if you need a solution without numerical damping.
ode23tb	Stiff	Low	If using crude error tolerances to solve stiff systems.

The algorithms used in the ODE solvers vary according to order of accuracy [6] and the type of systems (stiff or nonstiff) they are designed to solve. See “Algorithms” on page 1-4756 for more details.

## Options

Different solvers accept different parameters in the options list. For more information, see `odeset` and “Integrator Options” in the MATLAB Mathematics documentation.



Parameters	ode45	ode23	ode113	ode15s	ode23s	ode23t	ode23tb
RelTol, AbsTol, NormControl	√	√	√	√	√	√	√
OutputFcn, OutputSel, Refine, Stats	√	√	√	√	√	√	√
NonNegative	√	√	√	√ *	—	√ *	√ *
Events	√	√	√	√	√	√	√
MaxStep, InitialStep	√	√	√	√	√	√	√
Jacobian, JPattern, Vectorized	—	—	—	√	√	√	√
Mass	√	√	√	√	√	√	√
MStateDependence	√	√	√	√	—	√	√
MvPattern	—	—	—	√	—	√	√
MassSingular	—	—	—	√	—	√	—
InitialSlope	—	—	—	√	—	√	—
MaxOrder, BDF	—	—	—	√	—	—	—

---

**Note** You can use the NonNegative parameter with ode15s, ode23t, and ode23tb only for those problems for which there is no mass matrix.

---

## Examples

### Example 1

An example of a nonstiff system is the system of equations describing the motion of a rigid body without external forces.

$$\begin{aligned}y_1' &= y_2 y_3 & y_1(0) &= 0 \\y_2' &= -y_1 y_3 & y_2(0) &= 1 \\y_3' &= -0.51 y_1 y_2 & y_3(0) &= 1\end{aligned}$$

To simulate this system, create a function `rigid` containing the equations

```
function dy = rigid(t,y)
dy = zeros(3,1); % a column vector
dy(1) = y(2) * y(3);
dy(2) = -y(1) * y(3);
dy(3) = -0.51 * y(1) * y(2);
```

In this example we change the error tolerances using the `odeset` command and solve on a time interval `[0 12]` with an initial condition vector `[0 1 1]` at time 0.

```
options = odeset('RelTol',1e-4,'AbsTol',[1e-4 1e-4 1e-5]);
[T,Y] = ode45(@rigid,[0 12],[0 1 1],options);
```

Plotting the columns of the returned array `Y` versus `T` shows the solution

```
plot(T,Y(:,1),'-',T,Y(:,2),'-.',T,Y(:,3),'-.')
```

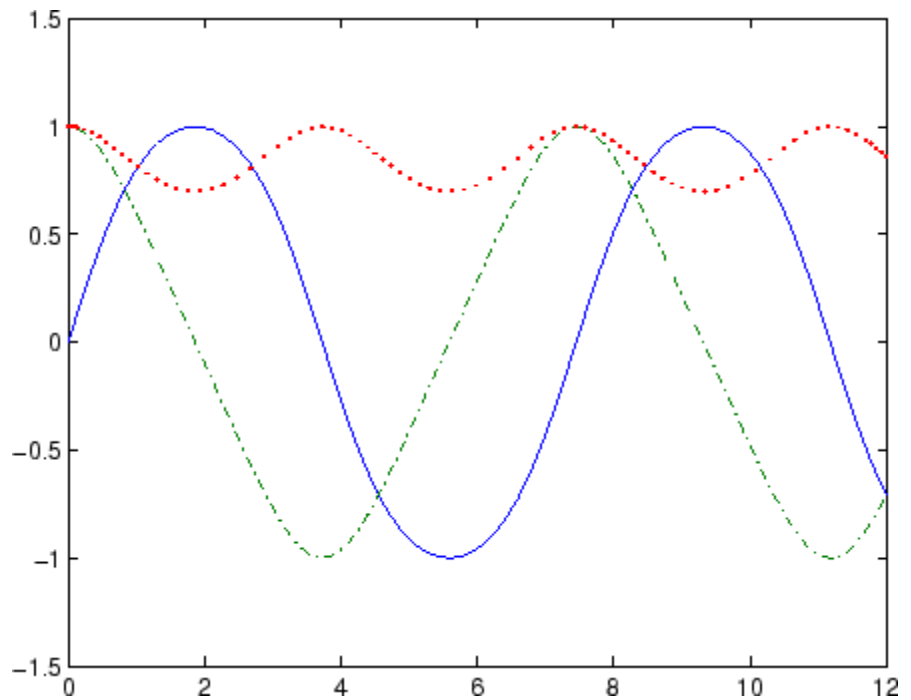

### Example 2

An example of a stiff system is provided by the van der Pol equations in relaxation oscillation. The limit cycle has portions where the solution components change slowly and the problem is quite stiff, alternating with regions of very sharp change where it is not stiff.

$$\begin{aligned} y_1' &= y_2 & y_1(0) &= 2 \\ y_2' &= 1000(1 - y_1^2)y_2 - y_1 & y_2(0) &= 0 \end{aligned}$$

To simulate this system, create a function `vdp1000` containing the equations

```
function dy = vdp1000(t,y)
```

# ode23tb

```
dy = zeros(2,1); % a column vector
dy(1) = y(2);
dy(2) = 1000*(1 - y(1)^2)*y(2) - y(1);
```

For this problem, we will use the default relative and absolute tolerances ( $1e-3$  and  $1e-6$ , respectively) and solve on a time interval of  $[0 \ 3000]$  with initial condition vector  $[2 \ 0]$  at time 0.

```
[T,Y] = ode15s(@vdp1000,[0 3000],[2 0]);
```

Plotting the first column of the returned matrix Y versus T shows the solution

```
plot(T,Y(:,1),'-o')
```

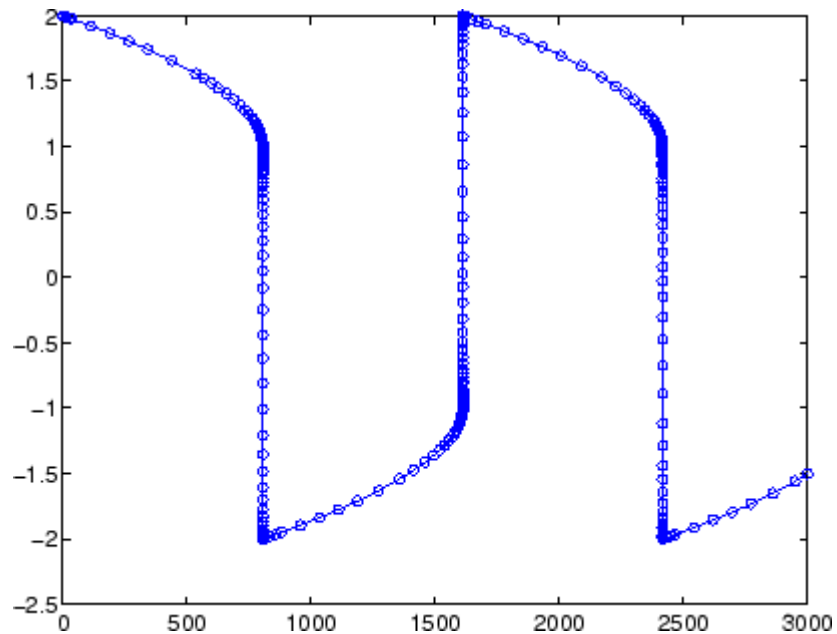

### Example 3

This example solves an ordinary differential equation with time-dependent terms.

Consider the following ODE, with time-dependent parameters defined only through the set of data points given in two vectors:

$$y'(t) + f(t)y(t) = g(t)$$

The initial condition is  $y(0) = 0$ , where the function  $f(t)$  is defined through the  $n$ -by-1 vectors  $tf$  and  $f$ , and the function  $g(t)$  is defined through the  $m$ -by-1 vectors  $tg$  and  $g$ .

First, define the time-dependent parameters  $f(t)$  and  $g(t)$  as the following:

```
ft = linspace(0,5,25); % Generate t for f
f = ft.^2 - ft - 3; % Generate f(t)
gt = linspace(1,6,25); % Generate t for g
g = 3*sin(gt-0.25); % Generate g(t)
```

Write a function to interpolate the data sets specified above to obtain the value of the time-dependent terms at the specified time:

```
function dydt = myode(t,y,ft,f,gt,g)
f = interp1(ft,f,t); % Interpolate the data set (ft,f) at time t
g = interp1(gt,g,t); % Interpolate the data set (gt,g) at time t
dydt = -f.*y + g; % Evaluate ODE at time t
```

Call the derivative function `myode.m` within the MATLAB `ode45` function specifying time as the first input argument :

```
Tspan = [1 5]; % Solve from t=1 to t=5
IC = 1; % y(t=0) = 1
[T Y] = ode45(@(t,y) myode(t,y,ft,f,gt,g),Tspan,IC); % Solve ODE
```

Plot the solution  $y(t)$  as a function of time:

```
plot(T, Y);
```

```
title('Plot of y as a function of time');
xlabel('Time'); ylabel('Y(t)');
```

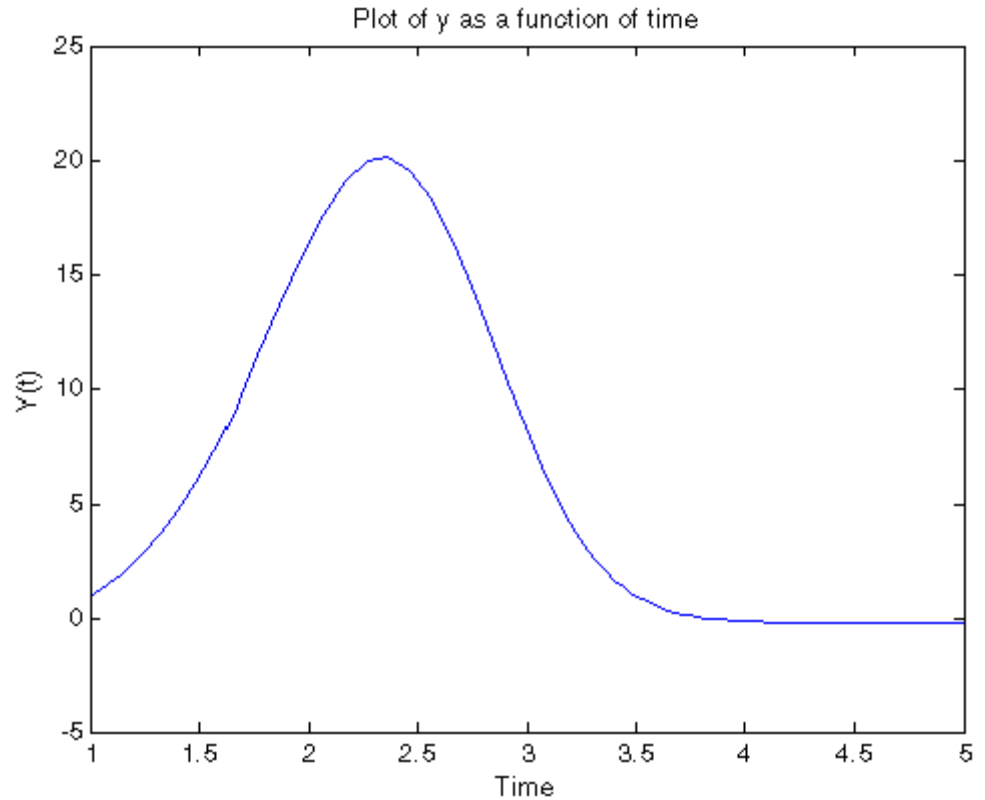

## Algorithms

ode45 is based on an explicit Runge-Kutta (4,5) formula, the Dormand-Prince pair. It is a *one-step* solver – in computing  $y(t_n)$ , it needs only the solution at the immediately preceding time point,  $y(t_{n-1})$ . In general, ode45 is the best function to apply as a *first try* for most problems. [3]

ode23 is an implementation of an explicit Runge-Kutta (2,3) pair of Bogacki and Shampine. It may be more efficient than ode45 at crude

tolerances and in the presence of moderate stiffness. Like `ode45`, `ode23` is a one-step solver. [2]

`ode113` is a variable order Adams-Bashforth-Moulton PECE solver. It may be more efficient than `ode45` at stringent tolerances and when the ODE file function is particularly expensive to evaluate. `ode113` is a *multistep* solver — it normally needs the solutions at several preceding time points to compute the current solution. [7]

The above algorithms are intended to solve nonstiff systems. If they appear to be unduly slow, try using one of the stiff solvers below.

`ode15s` is a variable order solver based on the numerical differentiation formulas (NDFs). Optionally, it uses the backward differentiation formulas (BDFs, also known as Gear’s method) that are usually less efficient. Like `ode113`, `ode15s` is a multistep solver. Try `ode15s` when `ode45` fails, or is very inefficient, and you suspect that the problem is stiff, or when solving a differential-algebraic problem. [9], [10]

`ode23s` is based on a modified Rosenbrock formula of order 2. Because it is a one-step solver, it may be more efficient than `ode15s` at crude tolerances. It can solve some kinds of stiff problems for which `ode15s` is not effective. [9]

`ode23t` is an implementation of the trapezoidal rule using a “free” interpolant. Use this solver if the problem is only moderately stiff and you need a solution without numerical damping. `ode23t` can solve DAEs. [10]

`ode23tb` is an implementation of TR-BDF2, an implicit Runge-Kutta formula with a first stage that is a trapezoidal rule step and a second stage that is a backward differentiation formula of order two. By construction, the same iteration matrix is used in evaluating both stages. Like `ode23s`, this solver may be more efficient than `ode15s` at crude tolerances. [8], [1]

## References

[1] Bank, R. E., W. C. Coughran, Jr., W. Fichtner, E. Grosse, D. Rose, and R. Smith, “Transient Simulation of Silicon Devices and Circuits,” *IEEE Trans. CAD*, 4 (1985), pp. 436–451.

- [2] Bogacki, P. and L. F. Shampine, “A 3(2) pair of Runge-Kutta formulas,” *Appl. Math. Letters*, Vol. 2, 1989, pp. 321–325.
- [3] Dormand, J. R. and P. J. Prince, “A family of embedded Runge-Kutta formulae,” *J. Comp. Appl. Math.*, Vol. 6, 1980, pp. 19–26.
- [4] Forsythe, G. , M. Malcolm, and C. Moler, *Computer Methods for Mathematical Computations*, Prentice-Hall, New Jersey, 1977.
- [5] Kahaner, D. , C. Moler, and S. Nash, *Numerical Methods and Software*, Prentice-Hall, New Jersey, 1989.
- [6] Shampine, L. F. , *Numerical Solution of Ordinary Differential Equations*, Chapman & Hall, New York, 1994.
- [7] Shampine, L. F. and M. K. Gordon, *Computer Solution of Ordinary Differential Equations: the Initial Value Problem*, W. H. Freeman, San Francisco, 1975.
- [8] Shampine, L. F. and M. E. Hosea, “Analysis and Implementation of TR-BDF2,” *Applied Numerical Mathematics* 20, 1996.
- [9] Shampine, L. F. and M. W. Reichelt, “The MATLAB ODE Suite,” *SIAM Journal on Scientific Computing*, Vol. 18, 1997, pp. 1–22.
- [10] Shampine, L. F., M. W. Reichelt, and J.A. Kierzenka, “Solving Index-1 DAEs in MATLAB and Simulink,” *SIAM Review*, Vol. 41, 1999, pp. 538–552.

## See Also

`deval` | `ode15i` | `odeget` | `odeset` | `function_handle`



**Purpose**

Solve nonstiff differential equations; medium order method

**Syntax**

```
[T,Y] = solver(odefun,tspan,y0)
[T,Y] = solver(odefun,tspan,y0,options)
[T,Y,TE,YE,IE] = solver(odefun,tspan,y0,options)
sol = solver(odefun,[t0 tf],y0...)
```

This page contains an overview of the solver functions: `ode23`, `ode45`, `ode113`, `ode15s`, `ode23s`, `ode23t`, and `ode23tb`. You can call any of these solvers by substituting the placeholder, `solver`, with any of the function names.

**Arguments**

The following table describes the input arguments to the solvers.

<code>odefun</code>	A function handle that evaluates the right side of the differential equations. All solvers solve systems of equations in the form $y' = f(t,y)$ or problems that involve a mass matrix, $M(t,y)y' = f(t,y)$ . The <code>ode23s</code> solver can solve only equations with constant mass matrices. <code>ode15s</code> and <code>ode23t</code> can solve problems with a mass matrix that is singular, i.e., differential-algebraic equations (DAEs).
<code>tspan</code>	A vector specifying the interval of integration, <code>[t0,tf]</code> . The solver imposes the initial conditions at <code>tspan(1)</code> , and integrates from <code>tspan(1)</code> to <code>tspan(end)</code> . To obtain solutions at specific times (all increasing or all decreasing), use <code>tspan = [t0,t1,...,tf]</code> .  For <code>tspan</code> vectors with two elements <code>[t0 tf]</code> , the solver returns the solution evaluated at every integration step. For <code>tspan</code> vectors with more than two elements, the solver returns solutions evaluated at the given time points. The time values must be in order, either increasing or decreasing.

Specifying `tspan` with more than two elements does not affect the internal time steps that the solver uses to traverse the interval from `tspan(1)` to `tspan(end)`. All solvers in the ODE suite obtain output values by means of continuous extensions of the basic formulas. Although a solver does not necessarily step precisely to a time point specified in `tspan`, the solutions produced at the specified time points are of the same order of accuracy as the solutions computed at the internal time points.

Specifying `tspan` with more than two elements has little effect on the efficiency of computation, but for large systems, affects memory management.

`y0`

A vector of initial conditions.

`options`

Structure of optional parameters that change the default integration properties. This is the fourth input argument.

```
[t,y] = solver(odefun,tspan,y0,options)
```

You can create options using the `odeset` function. See `odeset` for details.

The following table lists the output arguments for the solvers.

T	Column vector of time points.
Y	Solution array. Each row in Y corresponds to the solution at a time returned in the corresponding row of T.
TE	The time at which an event occurs.
YE	The solution at the time of the event.

IE            The index  $i$  of the event function that vanishes.  
 sol          Structure to evaluate the solution.

## Description

$[T,Y] = \text{solver}(\text{odefun},\text{tspan},\text{y0})$  with  $\text{tspan} = [t_0 \text{ } t_f]$  integrates the system of differential equations  $y' = f(t,y)$  from time  $t_0$  to  $t_f$  with initial conditions  $y_0$ . The first input argument, `odefun`, is a function handle. The function,  $f = \text{odefun}(t,y)$ , for a scalar  $t$  and a column vector  $y$ , must return a column vector  $f$  corresponding to  $f(t,y)$ . Each row in the solution array  $Y$  corresponds to a time returned in column vector  $T$ . To obtain solutions at the specific times  $t_0, t_1, \dots, t_f$  (all increasing or all decreasing), use  $\text{tspan} = [t_0, t_1, \dots, t_f]$ .

“Parameterizing Functions” explains how to provide additional parameters to the function `fun`, if necessary.

$[T,Y] = \text{solver}(\text{odefun},\text{tspan},\text{y0},\text{options})$  solves as above with default integration parameters replaced by property values specified in `options`, an argument created with the `odeset` function. Commonly used properties include a scalar relative error tolerance `RelTol` ( $1e-3$  by default) and a vector of absolute error tolerances `AbsTol` (all components are  $1e-6$  by default). If certain components of the solution must be nonnegative, use the `odeset` function to set the `NonNegative` property to the indices of these components. See `odeset` for details.

$[T,Y,TE,YE,IE] = \text{solver}(\text{odefun},\text{tspan},\text{y0},\text{options})$  solves as above while also finding where functions of  $(t,y)$ , called event functions, are zero. For each event function, you specify whether the integration is to terminate at a zero and whether the direction of the zero crossing matters. Do this by setting the 'Events' property to a function, e.g., `events` or `@events`, and creating a function  $[\text{value},\text{isterminal},\text{direction}] = \text{events}(t,y)$ . For the  $i$ th event function in `events`,

- `value(i)` is the value of the function.
- `isterminal(i) = 1`, if the integration is to terminate at a zero of this event function and 0 otherwise.

- `direction(i)` = 0 if all zeros are to be computed (the default), +1 if only the zeros where the event function increases, and -1 if only the zeros where the event function decreases.

Corresponding entries in `TE`, `YE`, and `IE` return, respectively, the time at which an event occurs, the solution at the time of the event, and the index `i` of the event function that vanishes.

`sol = solver(odefun,[t0 tf],y0...)` returns a structure that you can use with `deval` to evaluate the solution at any point on the interval `[t0,tf]`. You must pass `odefun` as a function handle. The structure `sol` always includes these fields:

<code>sol.x</code>	Steps chosen by the solver.
<code>sol.y</code>	Each column <code>sol.y(:,i)</code> contains the solution at <code>sol.x(i)</code> .
<code>sol.solver</code>	Solver name.

If you specify the `Events` option and events are detected, `sol` also includes these fields:

<code>sol.xe</code>	Points at which events, if any, occurred. <code>sol.xe(end)</code> contains the exact point of a terminal event, if any.
<code>sol.ye</code>	Solutions that correspond to events in <code>sol.xe</code> .
<code>sol.ie</code>	Indices into the vector returned by the function specified in the <code>Events</code> option. The values indicate which event the solver detected.

If you specify an output function as the value of the `OutputFcn` property, the solver calls it with the computed solution after each time step. Four output functions are provided: `odeplot`, `odephas2`, `odephas3`, `odeprint`. When you call the solver with no output arguments, it calls the default `odeplot` to plot the solution as it is computed. `odephas2` and `odephas3` produce two- and three-dimensional phase plane plots, respectively. `odeprint` displays the solution components on the screen.

By default, the ODE solver passes all components of the solution to the output function. You can pass only specific components by providing a vector of indices as the value of the `OutputSel` property. For example, if you call the solver with no output arguments and set the value of `OutputSel` to `[1,3]`, the solver plots solution components 1 and 3 as they are computed.

For the stiff solvers `ode15s`, `ode23s`, `ode23t`, and `ode23tb`, the Jacobian matrix  $\partial f/\partial y$  is critical to reliability and efficiency. Use `odeset` to set `Jacobian` to `@FJAC` if `FJAC(T,Y)` returns the Jacobian  $\partial f/\partial y$  or to the matrix  $\partial f/\partial y$  if the Jacobian is constant. If the `Jacobian` property is not set (the default),  $\partial f/\partial y$  is approximated by finite differences. Set the `Vectorized` property 'on' if the ODE function is coded so that `odefun(T,[Y1,Y2 ...])` returns `[odefun(T,Y1),odefun(T,Y2) ...]`. If  $\partial f/\partial y$  is a sparse matrix, set the `JPattern` property to the sparsity pattern of  $\partial f/\partial y$ , i.e., a sparse matrix `S` with `S(i,j) = 1` if the *i*th component of  $f(t,y)$  depends on the *j*th component of  $y$ , and 0 otherwise.

The solvers of the ODE suite can solve problems of the form  $M(t,y)y' = f(t,y)$ , with time- and state-dependent mass matrix  $M$ . (The `ode23s` solver can solve only equations with constant mass matrices.) If a problem has a mass matrix, create a function `M = MASS(t,y)` that returns the value of the mass matrix, and use `odeset` to set the `Mass` property to `@MASS`. If the mass matrix is constant, the matrix should be used as the value of the `Mass` property. Problems with state-dependent mass matrices are more difficult:

- If the mass matrix does not depend on the state variable  $y$  and the function `MASS` is to be called with one input argument, `t`, set the `MStateDependence` property to 'none'.
- If the mass matrix depends weakly on  $y$ , set `MStateDependence` to 'weak' (the default); otherwise, set it to 'strong'. In either case, the function `MASS` is called with the two arguments `(t,y)`.

If there are many differential equations, it is important to exploit sparsity:

- Return a sparse  $M(t,y)$ .

- Supply the sparsity pattern of  $\partial f/\partial y$  using the `JPattern` property or a sparse  $\partial f/\partial y$  using the `Jacobian` property.
- For strongly state-dependent  $M(t,y)$ , set `MVPattern` to a sparse matrix `S` with `S(i,j) = 1` if for any `k`, the `(i,k)` component of  $M(t,y)$  depends on component `j` of `y`, and `0` otherwise.

If the mass matrix  $M$  is singular, then  $M(t,y)y' = f(t,y)$  is a system of differential algebraic equations. DAEs have solutions only when  $y_0$  is consistent, that is, if there is a vector  $yp_0$  such that  $M(t_0,y_0)yp_0 = f(t_0,y_0)$ . The `ode15s` and `ode23t` solvers can solve DAEs of index 1 provided that  $y_0$  is sufficiently close to being consistent. If there is a mass matrix, you can use `odeset` to set the `MassSingular` property to 'yes', 'no', or 'maybe'. The default value of 'maybe' causes the solver to test whether the problem is a DAE. You can provide `yp0` as the value of the `InitialSlope` property. The default is the zero vector. If a problem is a DAE, and  $y_0$  and  $yp_0$  are not consistent, the solver treats them as guesses, attempts to compute consistent values that are close to the guesses, and continues to solve the problem. When solving DAEs, it is very advantageous to formulate the problem so that  $M$  is a diagonal matrix (a semi-explicit DAE).

Solver	Problem Type	Order of Accuracy	When to Use
ode45	Nonstiff	Medium	Most of the time. This should be the first solver you try.
ode23	Nonstiff	Low	For problems with crude error tolerances or for solving moderately stiff problems.

<b>Solver</b>	<b>Problem Type</b>	<b>Order of Accuracy</b>	<b>When to Use</b>
ode113	Nonstiff	Low to high	For problems with stringent error tolerances or for solving computationally intensive problems.
ode15s	Stiff	Low to medium	If ode45 is slow because the problem is stiff.
ode23s	Stiff	Low	If using crude error tolerances to solve stiff systems and the mass matrix is constant.
ode23t	Moderately Stiff	Low	For moderately stiff problems if you need a solution without numerical damping.
ode23tb	Stiff	Low	If using crude error tolerances to solve stiff systems.

The algorithms used in the ODE solvers vary according to order of accuracy [6] and the type of systems (stiff or nonstiff) they are designed to solve. See “Algorithms” on page 1-4771 for more details.

## Options

Different solvers accept different parameters in the options list. For more information, see `odeset` and “Integrator Options” in the MATLAB Mathematics documentation.

# ode45

Parameters	ode45	ode23	ode113	ode15s	ode23s	ode23t	ode23tb
RelTol, AbsTol, NormControl	√	√	√	√	√	√	√
OutputFcn, OutputSel, Refine, Stats	√	√	√	√	√	√	√
NonNegative	√	√	√	√ *	—	√ *	√ *
Events	√	√	√	√	√	√	√
MaxStep, InitialStep	√	√	√	√	√	√	√
Jacobian, JPattern, Vectorized	—	—	—	√	√	√	√
Mass	√	√	√	√	√	√	√
MStateDependence	√	√	√	√	—	√	√
MvPattern	—	—	—	√	—	√	√
MassSingular	—	—	—	√	—	√	—
InitialSlope	—	—	—	√	—	√	—
MaxOrder, BDF	—	—	—	√	—	—	—

---

**Note** You can use the NonNegative parameter with ode15s, ode23t, and ode23tb only for those problems for which there is no mass matrix.

---

## Examples

### Example 1

An example of a nonstiff system is the system of equations describing the motion of a rigid body without external forces.



$$\begin{aligned}y_1' &= y_2 y_3 & y_1(0) &= 0 \\y_2' &= -y_1 y_3 & y_2(0) &= 1 \\y_3' &= -0.51 y_1 y_2 & y_3(0) &= 1\end{aligned}$$

To simulate this system, create a function `rigid` containing the equations

```
function dy = rigid(t,y)
dy = zeros(3,1); % a column vector
dy(1) = y(2) * y(3);
dy(2) = -y(1) * y(3);
dy(3) = -0.51 * y(1) * y(2);
```

In this example we change the error tolerances using the `odeset` command and solve on a time interval `[0 12]` with an initial condition vector `[0 1 1]` at time 0.

```
options = odeset('RelTol',1e-4,'AbsTol',[1e-4 1e-4 1e-5]);
[T,Y] = ode45(@rigid,[0 12],[0 1 1],options);
```

Plotting the columns of the returned array `Y` versus `T` shows the solution

```
plot(T,Y(:,1),'-',T,Y(:,2),'-.',T,Y(:,3),'.')
```

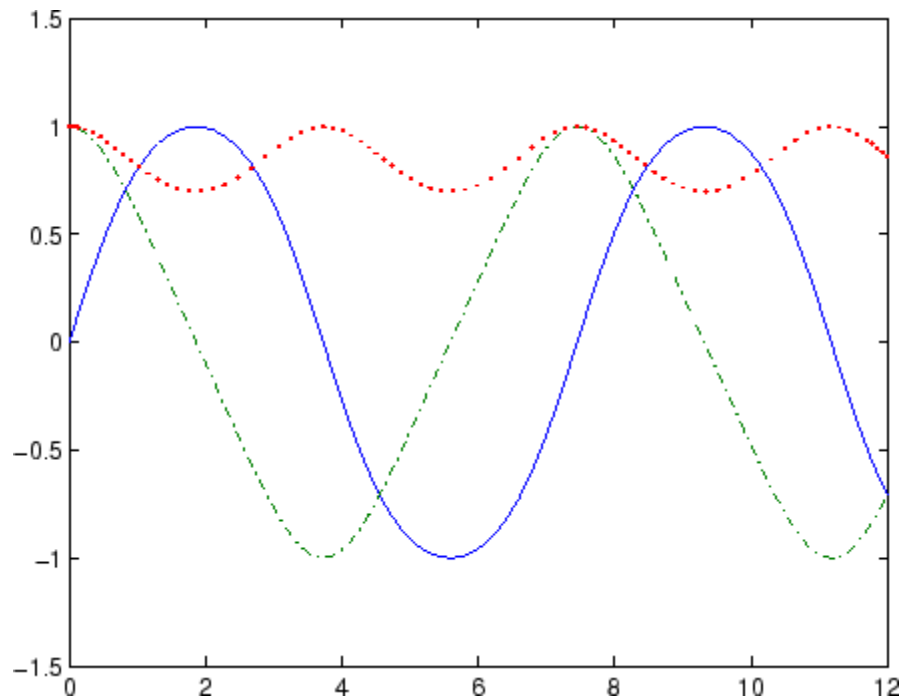

### Example 2

An example of a stiff system is provided by the van der Pol equations in relaxation oscillation. The limit cycle has portions where the solution components change slowly and the problem is quite stiff, alternating with regions of very sharp change where it is not stiff.

$$\begin{aligned} y_1' &= y_2 & y_1(0) &= 2 \\ y_2' &= 1000(1 - y_1^2)y_2 - y_1 & y_2(0) &= 0 \end{aligned}$$

To simulate this system, create a function `vdp1000` containing the equations

```
function dy = vdp1000(t,y)
```

```
dy = zeros(2,1); % a column vector
dy(1) = y(2);
dy(2) = 1000*(1 - y(1)^2)*y(2) - y(1);
```

For this problem, we will use the default relative and absolute tolerances ( $1e-3$  and  $1e-6$ , respectively) and solve on a time interval of  $[0 \ 3000]$  with initial condition vector  $[2 \ 0]$  at time 0.

```
[T,Y] = ode15s(@vdp1000,[0 3000],[2 0]);
```

Plotting the first column of the returned matrix Y versus T shows the solution

```
plot(T,Y(:,1),'-o')
```

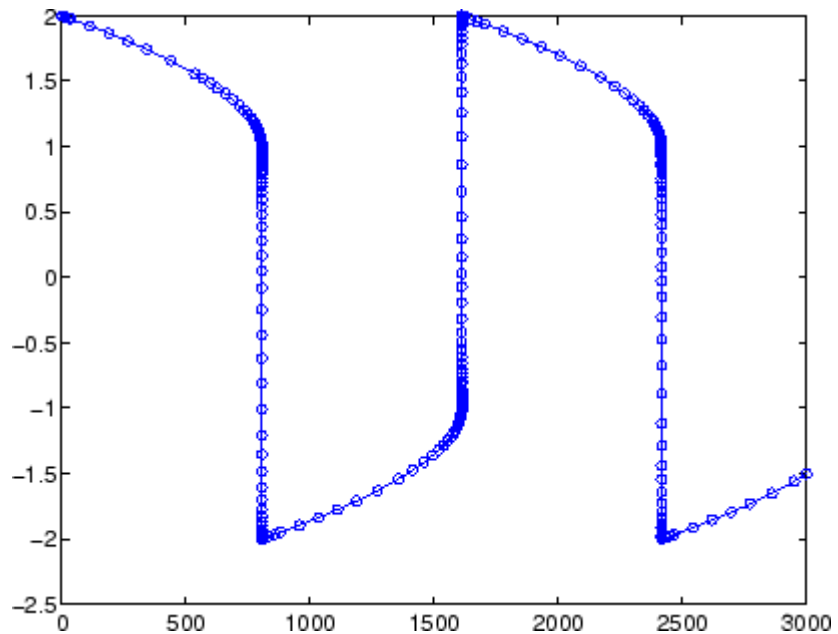

## Example 3

This example solves an ordinary differential equation with time-dependent terms.

Consider the following ODE, with time-dependent parameters defined only through the set of data points given in two vectors:

$$y'(t) + f(t)y(t) = g(t)$$

The initial condition is  $y(0) = 0$ , where the function  $f(t)$  is defined through the  $n$ -by-1 vectors  $tf$  and  $f$ , and the function  $g(t)$  is defined through the  $m$ -by-1 vectors  $tg$  and  $g$ .

First, define the time-dependent parameters  $f(t)$  and  $g(t)$  as the following:

```
ft = linspace(0,5,25); % Generate t for f
f = ft.^2 - ft - 3; % Generate f(t)
gt = linspace(1,6,25); % Generate t for g
g = 3*sin(gt-0.25); % Generate g(t)
```

Write a function to interpolate the data sets specified above to obtain the value of the time-dependent terms at the specified time:

```
function dydt = myode(t,y,ft,f,gt,g)
f = interp1(ft,f,t); % Interpolate the data set (ft,f) at time t
g = interp1(gt,g,t); % Interpolate the data set (gt,g) at time t
dydt = -f.*y + g; % Evaluate ODE at time t
```

Call the derivative function `myode.m` within the MATLAB `ode45` function specifying time as the first input argument :

```
Tspan = [1 5]; % Solve from t=1 to t=5
IC = 1; % y(t=0) = 1
[T Y] = ode45(@(t,y) myode(t,y,ft,f,gt,g),Tspan,IC); % Solve ODE
```

Plot the solution  $y(t)$  as a function of time:

```
plot(T, Y);
```

```
title('Plot of y as a function of time');
xlabel('Time'); ylabel('Y(t)');
```

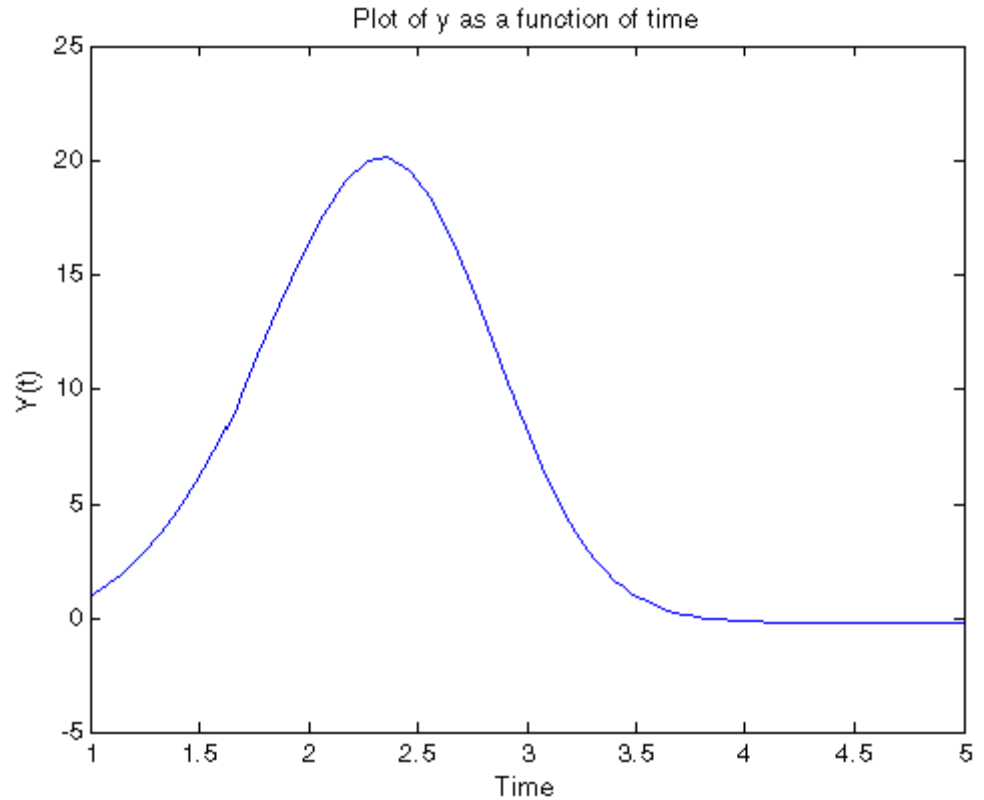

## Algorithms

ode45 is based on an explicit Runge-Kutta (4,5) formula, the Dormand-Prince pair. It is a *one-step* solver – in computing  $y(t_n)$ , it needs only the solution at the immediately preceding time point,  $y(t_{n-1})$ . In general, ode45 is the best function to apply as a *first try* for most problems. [3]

ode23 is an implementation of an explicit Runge-Kutta (2,3) pair of Bogacki and Shampine. It may be more efficient than ode45 at crude

tolerances and in the presence of moderate stiffness. Like `ode45`, `ode23` is a one-step solver. [2]

`ode113` is a variable order Adams-Bashforth-Moulton PECE solver. It may be more efficient than `ode45` at stringent tolerances and when the ODE file function is particularly expensive to evaluate. `ode113` is a *multistep* solver — it normally needs the solutions at several preceding time points to compute the current solution. [7]

The above algorithms are intended to solve nonstiff systems. If they appear to be unduly slow, try using one of the stiff solvers below.

`ode15s` is a variable order solver based on the numerical differentiation formulas (NDFs). Optionally, it uses the backward differentiation formulas (BDFs, also known as Gear's method) that are usually less efficient. Like `ode113`, `ode15s` is a multistep solver. Try `ode15s` when `ode45` fails, or is very inefficient, and you suspect that the problem is stiff, or when solving a differential-algebraic problem. [9], [10]

`ode23s` is based on a modified Rosenbrock formula of order 2. Because it is a one-step solver, it may be more efficient than `ode15s` at crude tolerances. It can solve some kinds of stiff problems for which `ode15s` is not effective. [9]

`ode23t` is an implementation of the trapezoidal rule using a “free” interpolant. Use this solver if the problem is only moderately stiff and you need a solution without numerical damping. `ode23t` can solve DAEs. [10]

`ode23tb` is an implementation of TR-BDF2, an implicit Runge-Kutta formula with a first stage that is a trapezoidal rule step and a second stage that is a backward differentiation formula of order two. By construction, the same iteration matrix is used in evaluating both stages. Like `ode23s`, this solver may be more efficient than `ode15s` at crude tolerances. [8], [1]

## References

[1] Bank, R. E., W. C. Coughran, Jr., W. Fichtner, E. Grosse, D. Rose, and R. Smith, “Transient Simulation of Silicon Devices and Circuits,” *IEEE Trans. CAD*, 4 (1985), pp. 436–451.

- [2] Bogacki, P. and L. F. Shampine, “A 3(2) pair of Runge-Kutta formulas,” *Appl. Math. Letters*, Vol. 2, 1989, pp. 321–325.
- [3] Dormand, J. R. and P. J. Prince, “A family of embedded Runge-Kutta formulae,” *J. Comp. Appl. Math.*, Vol. 6, 1980, pp. 19–26.
- [4] Forsythe, G. , M. Malcolm, and C. Moler, *Computer Methods for Mathematical Computations*, Prentice-Hall, New Jersey, 1977.
- [5] Kahaner, D. , C. Moler, and S. Nash, *Numerical Methods and Software*, Prentice-Hall, New Jersey, 1989.
- [6] Shampine, L. F. , *Numerical Solution of Ordinary Differential Equations*, Chapman & Hall, New York, 1994.
- [7] Shampine, L. F. and M. K. Gordon, *Computer Solution of Ordinary Differential Equations: the Initial Value Problem*, W. H. Freeman, San Francisco, 1975.
- [8] Shampine, L. F. and M. E. Hosea, “Analysis and Implementation of TR-BDF2,” *Applied Numerical Mathematics* 20, 1996.
- [9] Shampine, L. F. and M. W. Reichelt, “The MATLAB ODE Suite,” *SIAM Journal on Scientific Computing*, Vol. 18, 1997, pp. 1–22.
- [10] Shampine, L. F., M. W. Reichelt, and J.A. Kierzenka, “Solving Index-1 DAEs in MATLAB and Simulink,” *SIAM Review*, Vol. 41, 1999, pp. 538–552.

**See Also**

deval | ode15i | odeget | odeset | function\_handle

**Purpose** Solve nonstiff differential equations; variable order method

**Syntax**

```
[T,Y] = solver(odefun,tspan,y0)
[T,Y] = solver(odefun,tspan,y0,options)
[T,Y,TE,YE,IE] = solver(odefun,tspan,y0,options)
sol = solver(odefun,[t0 tf],y0...)
```

This page contains an overview of the solver functions: `ode23`, `ode45`, `ode113`, `ode15s`, `ode23s`, `ode23t`, and `ode23tb`. You can call any of these solvers by substituting the placeholder, `solver`, with any of the function names.

**Arguments** The following table describes the input arguments to the solvers.

<code>odefun</code>	A function handle that evaluates the right side of the differential equations. All solvers solve systems of equations in the form $y' = f(t,y)$ or problems that involve a mass matrix, $M(t,y)y' = f(t,y)$ . The <code>ode23s</code> solver can solve only equations with constant mass matrices. <code>ode15s</code> and <code>ode23t</code> can solve problems with a mass matrix that is singular, i.e., differential-algebraic equations (DAEs).
<code>tspan</code>	A vector specifying the interval of integration, <code>[t0,tf]</code> . The solver imposes the initial conditions at <code>tspan(1)</code> , and integrates from <code>tspan(1)</code> to <code>tspan(end)</code> . To obtain solutions at specific times (all increasing or all decreasing), use <code>tspan = [t0,t1,...,tf]</code> .  For <code>tspan</code> vectors with two elements <code>[t0 tf]</code> , the solver returns the solution evaluated at every integration step. For <code>tspan</code> vectors with more than two elements, the solver returns solutions evaluated at the given time points. The time values must be in order, either increasing or decreasing.



Specifying `tspan` with more than two elements does not affect the internal time steps that the solver uses to traverse the interval from `tspan(1)` to `tspan(end)`. All solvers in the ODE suite obtain output values by means of continuous extensions of the basic formulas. Although a solver does not necessarily step precisely to a time point specified in `tspan`, the solutions produced at the specified time points are of the same order of accuracy as the solutions computed at the internal time points.

Specifying `tspan` with more than two elements has little effect on the efficiency of computation, but for large systems, affects memory management.

`y0`

A vector of initial conditions.

`options`

Structure of optional parameters that change the default integration properties. This is the fourth input argument.

```
[t,y] = solver(odefun,tspan,y0,options)
```

You can create options using the `odeset` function. See `odeset` for details.

The following table lists the output arguments for the solvers.

<code>T</code>	Column vector of time points.
<code>Y</code>	Solution array. Each row in <code>Y</code> corresponds to the solution at a time returned in the corresponding row of <code>T</code> .
<code>TE</code>	The time at which an event occurs.
<code>YE</code>	The solution at the time of the event.

IE            The index *i* of the event function that vanishes.  
sol           Structure to evaluate the solution.

## Description

$[T, Y] = \text{solver}(\text{odefun}, \text{tspan}, y_0)$  with  $\text{tspan} = [t_0 \text{ } t_f]$  integrates the system of differential equations  $y' = f(t, y)$  from time  $t_0$  to  $t_f$  with initial conditions  $y_0$ . The first input argument, `odefun`, is a function handle. The function,  $f = \text{odefun}(t, y)$ , for a scalar  $t$  and a column vector  $y$ , must return a column vector  $f$  corresponding to  $f(t, y)$ . Each row in the solution array  $Y$  corresponds to a time returned in column vector  $T$ . To obtain solutions at the specific times  $t_0, t_1, \dots, t_f$  (all increasing or all decreasing), use  $\text{tspan} = [t_0, t_1, \dots, t_f]$ .

“Parameterizing Functions” explains how to provide additional parameters to the function `fun`, if necessary.

$[T, Y] = \text{solver}(\text{odefun}, \text{tspan}, y_0, \text{options})$  solves as above with default integration parameters replaced by property values specified in `options`, an argument created with the `odeset` function. Commonly used properties include a scalar relative error tolerance `RelTol` ( $1e-3$  by default) and a vector of absolute error tolerances `AbsTol` (all components are  $1e-6$  by default). If certain components of the solution must be nonnegative, use the `odeset` function to set the `NonNegative` property to the indices of these components. See `odeset` for details.

$[T, Y, TE, YE, IE] = \text{solver}(\text{odefun}, \text{tspan}, y_0, \text{options})$  solves as above while also finding where functions of  $(t, y)$ , called event functions, are zero. For each event function, you specify whether the integration is to terminate at a zero and whether the direction of the zero crossing matters. Do this by setting the 'Events' property to a function, e.g., `events` or `@events`, and creating a function  $[\text{value}, \text{isterminal}, \text{direction}] = \text{events}(t, y)$ . For the  $i$ th event function in `events`,

- `value(i)` is the value of the function.
- `isterminal(i) = 1`, if the integration is to terminate at a zero of this event function and 0 otherwise.

- `direction(i) = 0` if all zeros are to be computed (the default), `+1` if only the zeros where the event function increases, and `-1` if only the zeros where the event function decreases.

Corresponding entries in `TE`, `YE`, and `IE` return, respectively, the time at which an event occurs, the solution at the time of the event, and the index `i` of the event function that vanishes.

`sol = solver(odefun,[t0 tf],y0...)` returns a structure that you can use with `deval` to evaluate the solution at any point on the interval `[t0,tf]`. You must pass `odefun` as a function handle. The structure `sol` always includes these fields:

<code>sol.x</code>	Steps chosen by the solver.
<code>sol.y</code>	Each column <code>sol.y(:,i)</code> contains the solution at <code>sol.x(i)</code> .
<code>sol.solver</code>	Solver name.

If you specify the `Events` option and events are detected, `sol` also includes these fields:

<code>sol.xe</code>	Points at which events, if any, occurred. <code>sol.xe(end)</code> contains the exact point of a terminal event, if any.
<code>sol.ye</code>	Solutions that correspond to events in <code>sol.xe</code> .
<code>sol.ie</code>	Indices into the vector returned by the function specified in the <code>Events</code> option. The values indicate which event the solver detected.

If you specify an output function as the value of the `OutputFcn` property, the solver calls it with the computed solution after each time step. Four output functions are provided: `odeplot`, `odephas2`, `odephas3`, `odeprint`. When you call the solver with no output arguments, it calls the default `odeplot` to plot the solution as it is computed. `odephas2` and `odephas3` produce two- and three-dimensional phase plane plots, respectively. `odeprint` displays the solution components on the screen.

By default, the ODE solver passes all components of the solution to the output function. You can pass only specific components by providing a vector of indices as the value of the `OutputSel` property. For example, if you call the solver with no output arguments and set the value of `OutputSel` to `[1,3]`, the solver plots solution components 1 and 3 as they are computed.

For the stiff solvers `ode15s`, `ode23s`, `ode23t`, and `ode23tb`, the Jacobian matrix  $\partial f/\partial y$  is critical to reliability and efficiency. Use `odeset` to set `Jacobian` to `@FJAC` if `FJAC(T,Y)` returns the Jacobian  $\partial f/\partial y$  or to the matrix  $\partial f/\partial y$  if the Jacobian is constant. If the `Jacobian` property is not set (the default),  $\partial f/\partial y$  is approximated by finite differences. Set the `Vectorized` property 'on' if the ODE function is coded so that `odefun(T,[Y1,Y2 ...])` returns `[odefun(T,Y1),odefun(T,Y2) ...]`. If  $\partial f/\partial y$  is a sparse matrix, set the `JPattern` property to the sparsity pattern of  $\partial f/\partial y$ , i.e., a sparse matrix `S` with `S(i,j) = 1` if the *i*th component of  $f(t,y)$  depends on the *j*th component of  $y$ , and 0 otherwise.

The solvers of the ODE suite can solve problems of the form  $M(t,y)y' = f(t,y)$ , with time- and state-dependent mass matrix  $M$ . (The `ode23s` solver can solve only equations with constant mass matrices.) If a problem has a mass matrix, create a function `M = MASS(t,y)` that returns the value of the mass matrix, and use `odeset` to set the `Mass` property to `@MASS`. If the mass matrix is constant, the matrix should be used as the value of the `Mass` property. Problems with state-dependent mass matrices are more difficult:

- If the mass matrix does not depend on the state variable  $y$  and the function `MASS` is to be called with one input argument, `t`, set the `MStateDependence` property to 'none'.
- If the mass matrix depends weakly on  $y$ , set `MStateDependence` to 'weak' (the default); otherwise, set it to 'strong'. In either case, the function `MASS` is called with the two arguments `(t,y)`.

If there are many differential equations, it is important to exploit sparsity:

- Return a sparse  $M(t,y)$ .

- Supply the sparsity pattern of  $\partial f/\partial y$  using the `JPattern` property or a sparse  $\partial f/\partial y$  using the `Jacobian` property.
- For strongly state-dependent  $M(t,y)$ , set `MvPattern` to a sparse matrix `S` with  $S(i, j) = 1$  if for any  $k$ , the  $(i, k)$  component of  $M(t,y)$  depends on component  $j$  of  $y$ , and 0 otherwise.

If the mass matrix  $M$  is singular, then  $M(t,y)y' = f(t,y)$  is a system of differential algebraic equations. DAEs have solutions only when  $y_0$  is consistent, that is, if there is a vector  $yp_0$  such that  $M(t_0,y_0)yp_0 = f(t_0,y_0)$ . The `ode15s` and `ode23t` solvers can solve DAEs of index 1 provided that  $y_0$  is sufficiently close to being consistent. If there is a mass matrix, you can use `odeset` to set the `MassSingular` property to 'yes', 'no', or 'maybe'. The default value of 'maybe' causes the solver to test whether the problem is a DAE. You can provide `yp0` as the value of the `InitialSlope` property. The default is the zero vector. If a problem is a DAE, and  $y_0$  and  $yp_0$  are not consistent, the solver treats them as guesses, attempts to compute consistent values that are close to the guesses, and continues to solve the problem. When solving DAEs, it is very advantageous to formulate the problem so that  $M$  is a diagonal matrix (a semi-explicit DAE).

<b>Solver</b>	<b>Problem Type</b>	<b>Order of Accuracy</b>	<b>When to Use</b>
ode45	Nonstiff	Medium	Most of the time. This should be the first solver you try.
ode23	Nonstiff	Low	For problems with crude error tolerances or for solving moderately stiff problems.

<b>Solver</b>	<b>Problem Type</b>	<b>Order of Accuracy</b>	<b>When to Use</b>
ode113	Nonstiff	Low to high	For problems with stringent error tolerances or for solving computationally intensive problems.
ode15s	Stiff	Low to medium	If ode45 is slow because the problem is stiff.
ode23s	Stiff	Low	If using crude error tolerances to solve stiff systems and the mass matrix is constant.
ode23t	Moderately Stiff	Low	For moderately stiff problems if you need a solution without numerical damping.
ode23tb	Stiff	Low	If using crude error tolerances to solve stiff systems.

The algorithms used in the ODE solvers vary according to order of accuracy [6] and the type of systems (stiff or nonstiff) they are designed to solve. See “Algorithms” on page 1-4786 for more details.

## Options

Different solvers accept different parameters in the options list. For more information, see `odeset` and “Integrator Options” in the MATLAB Mathematics documentation.

Parameters	ode45	ode23	ode113	ode15s	ode23s	ode23t	ode23tb
RelTol, AbsTol, NormControl	√	√	√	√	√	√	√
OutputFcn, OutputSel, Refine, Stats	√	√	√	√	√	√	√
NonNegative	√	√	√	√ *	—	√ *	√ *
Events	√	√	√	√	√	√	√
MaxStep, InitialStep	√	√	√	√	√	√	√
Jacobian, JPattern, Vectorized	—	—	—	√	√	√	√
Mass	√	√	√	√	√	√	√
MStateDependence	√	√	√	√	—	√	√
MvPattern	—	—	—	√	—	√	√
MassSingular	—	—	—	√	—	√	—
InitialSlope	—	—	—	√	—	√	—
MaxOrder, BDF	—	—	—	√	—	—	—

---

**Note** You can use the NonNegative parameter with ode15s, ode23t, and ode23tb only for those problems for which there is no mass matrix.

---

## Examples

### Example 1

An example of a nonstiff system is the system of equations describing the motion of a rigid body without external forces.

$$\begin{aligned}y_1' &= y_2 y_3 & y_1(0) &= 0 \\y_2' &= -y_1 y_3 & y_2(0) &= 1 \\y_3' &= -0.51 y_1 y_2 & y_3(0) &= 1\end{aligned}$$

To simulate this system, create a function `rigid` containing the equations

```
function dy = rigid(t,y)
dy = zeros(3,1); % a column vector
dy(1) = y(2) * y(3);
dy(2) = -y(1) * y(3);
dy(3) = -0.51 * y(1) * y(2);
```

In this example we change the error tolerances using the `odeset` command and solve on a time interval `[0 12]` with an initial condition vector `[0 1 1]` at time 0.

```
options = odeset('RelTol',1e-4,'AbsTol',[1e-4 1e-4 1e-5]);
[T,Y] = ode45(@rigid,[0 12],[0 1 1],options);
```

Plotting the columns of the returned array `Y` versus `T` shows the solution

```
plot(T,Y(:,1),'-',T,Y(:,2),'-.',T,Y(:,3),'-.')
```



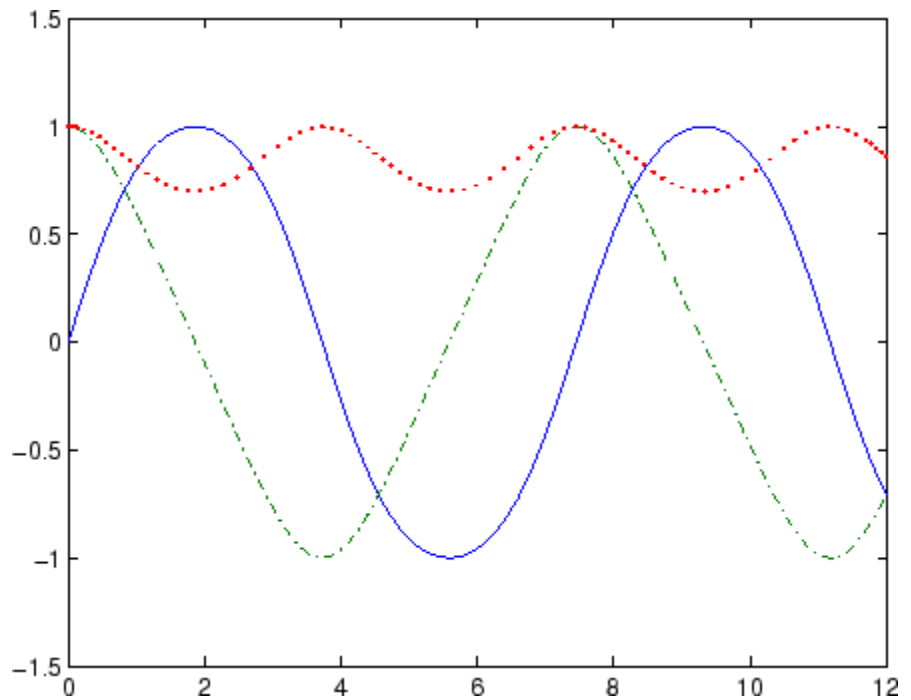

### Example 2

An example of a stiff system is provided by the van der Pol equations in relaxation oscillation. The limit cycle has portions where the solution components change slowly and the problem is quite stiff, alternating with regions of very sharp change where it is not stiff.

$$\begin{aligned} y_1' &= y_2 & y_1(0) &= 2 \\ y_2' &= 1000(1 - y_1^2)y_2 - y_1 & y_2(0) &= 0 \end{aligned}$$

To simulate this system, create a function `vdp1000` containing the equations

```
function dy = vdp1000(t,y)
```

# ode113

```
dy = zeros(2,1); % a column vector
dy(1) = y(2);
dy(2) = 1000*(1 - y(1)^2)*y(2) - y(1);
```

For this problem, we will use the default relative and absolute tolerances ( $1e-3$  and  $1e-6$ , respectively) and solve on a time interval of  $[0 \ 3000]$  with initial condition vector  $[2 \ 0]$  at time 0.

```
[T,Y] = ode15s(@vdp1000,[0 3000],[2 0]);
```

Plotting the first column of the returned matrix Y versus T shows the solution

```
plot(T,Y(:,1),'-o')
```

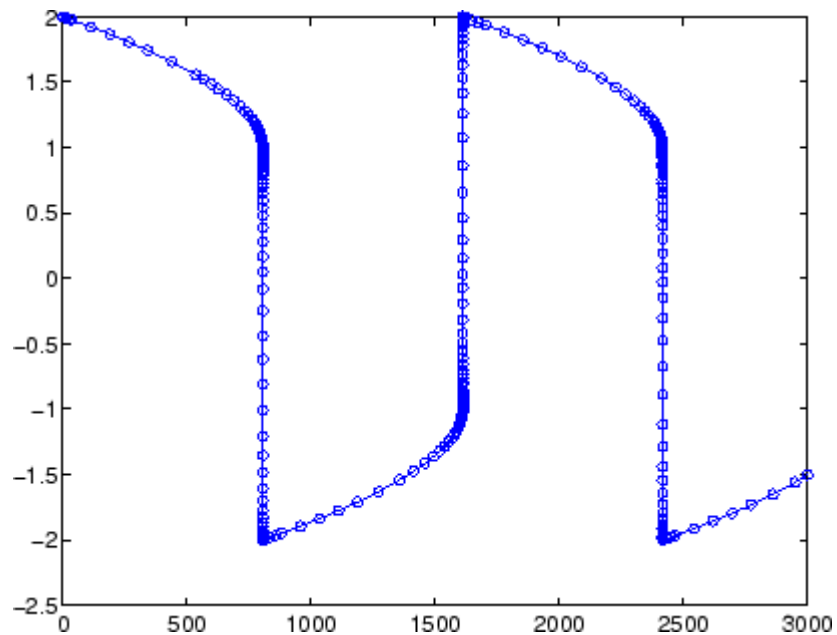

**Example 3**

This example solves an ordinary differential equation with time-dependent terms.

Consider the following ODE, with time-dependent parameters defined only through the set of data points given in two vectors:

$$y'(t) + f(t)y(t) = g(t)$$

The initial condition is  $y(0) = 0$ , where the function  $f(t)$  is defined through the  $n$ -by-1 vectors  $tf$  and  $f$ , and the function  $g(t)$  is defined through the  $m$ -by-1 vectors  $tg$  and  $g$ .

First, define the time-dependent parameters  $f(t)$  and  $g(t)$  as the following:

```
ft = linspace(0,5,25); % Generate t for f
f = ft.^2 - ft - 3; % Generate f(t)
gt = linspace(1,6,25); % Generate t for g
g = 3*sin(gt-0.25); % Generate g(t)
```

Write a function to interpolate the data sets specified above to obtain the value of the time-dependent terms at the specified time:

```
function dydt = myode(t,y,ft,f,gt,g)
f = interp1(ft,f,t); % Interpolate the data set (ft,f) at time t
g = interp1(gt,g,t); % Interpolate the data set (gt,g) at time t
dydt = -f.*y + g; % Evaluate ODE at time t
```

Call the derivative function `myode.m` within the MATLAB `ode45` function specifying time as the first input argument :

```
Tspan = [1 5]; % Solve from t=1 to t=5
IC = 1; % y(t=0) = 1
[T Y] = ode45(@(t,y) myode(t,y,ft,f,gt,g),Tspan,IC); % Solve ODE
```

Plot the solution  $y(t)$  as a function of time:

```
plot(T, Y);
```

```
title('Plot of y as a function of time');
xlabel('Time'); ylabel('Y(t)');
```

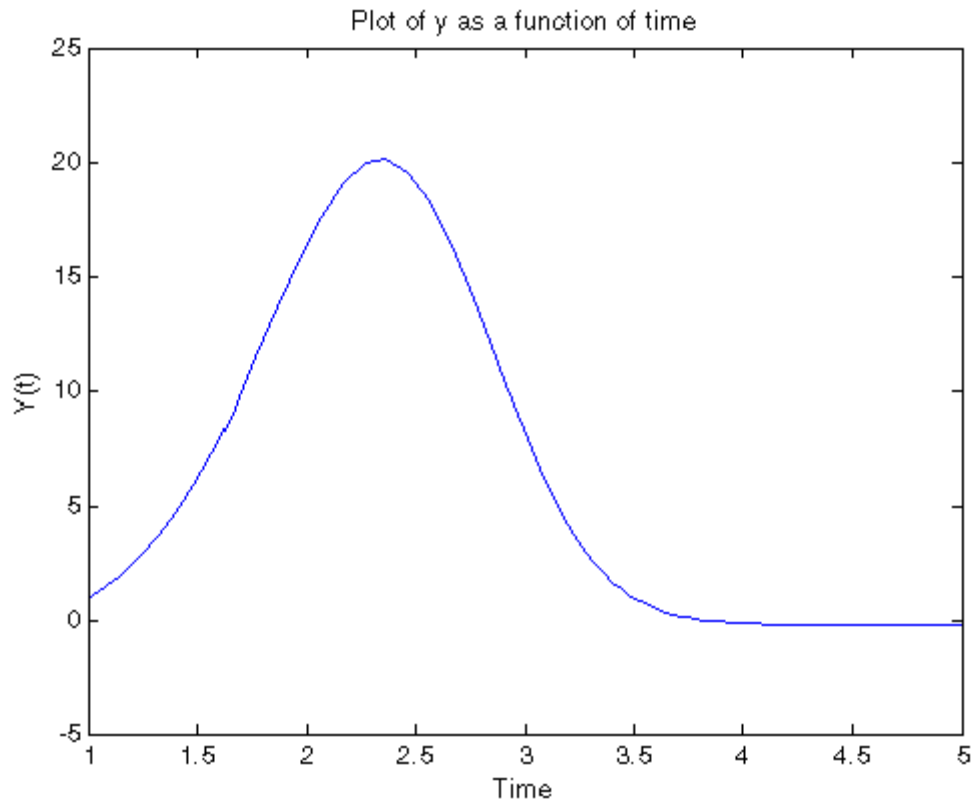

## Algorithms

`ode45` is based on an explicit Runge-Kutta (4,5) formula, the Dormand-Prince pair. It is a *one-step* solver – in computing  $y(t_n)$ , it needs only the solution at the immediately preceding time point,  $y(t_{n-1})$ . In general, `ode45` is the best function to apply as a *first try* for most problems. [3]

`ode23` is an implementation of an explicit Runge-Kutta (2,3) pair of Bogacki and Shampine. It may be more efficient than `ode45` at crude

tolerances and in the presence of moderate stiffness. Like `ode45`, `ode23` is a one-step solver. [2]

`ode113` is a variable order Adams-Bashforth-Moulton PECE solver. It may be more efficient than `ode45` at stringent tolerances and when the ODE file function is particularly expensive to evaluate. `ode113` is a *multistep* solver — it normally needs the solutions at several preceding time points to compute the current solution. [7]

The above algorithms are intended to solve nonstiff systems. If they appear to be unduly slow, try using one of the stiff solvers below.

`ode15s` is a variable order solver based on the numerical differentiation formulas (NDFs). Optionally, it uses the backward differentiation formulas (BDFs, also known as Gear’s method) that are usually less efficient. Like `ode113`, `ode15s` is a multistep solver. Try `ode15s` when `ode45` fails, or is very inefficient, and you suspect that the problem is stiff, or when solving a differential-algebraic problem. [9], [10]

`ode23s` is based on a modified Rosenbrock formula of order 2. Because it is a one-step solver, it may be more efficient than `ode15s` at crude tolerances. It can solve some kinds of stiff problems for which `ode15s` is not effective. [9]

`ode23t` is an implementation of the trapezoidal rule using a “free” interpolant. Use this solver if the problem is only moderately stiff and you need a solution without numerical damping. `ode23t` can solve DAEs. [10]

`ode23tb` is an implementation of TR-BDF2, an implicit Runge-Kutta formula with a first stage that is a trapezoidal rule step and a second stage that is a backward differentiation formula of order two. By construction, the same iteration matrix is used in evaluating both stages. Like `ode23s`, this solver may be more efficient than `ode15s` at crude tolerances. [8], [1]

## References

[1] Bank, R. E., W. C. Coughran, Jr., W. Fichtner, E. Grosse, D. Rose, and R. Smith, “Transient Simulation of Silicon Devices and Circuits,” *IEEE Trans. CAD*, 4 (1985), pp. 436–451.

- [2] Bogacki, P. and L. F. Shampine, “A 3(2) pair of Runge-Kutta formulas,” *Appl. Math. Letters*, Vol. 2, 1989, pp. 321–325.
- [3] Dormand, J. R. and P. J. Prince, “A family of embedded Runge-Kutta formulae,” *J. Comp. Appl. Math.*, Vol. 6, 1980, pp. 19–26.
- [4] Forsythe, G. , M. Malcolm, and C. Moler, *Computer Methods for Mathematical Computations*, Prentice-Hall, New Jersey, 1977.
- [5] Kahaner, D. , C. Moler, and S. Nash, *Numerical Methods and Software*, Prentice-Hall, New Jersey, 1989.
- [6] Shampine, L. F. , *Numerical Solution of Ordinary Differential Equations*, Chapman & Hall, New York, 1994.
- [7] Shampine, L. F. and M. K. Gordon, *Computer Solution of Ordinary Differential Equations: the Initial Value Problem*, W. H. Freeman, San Francisco, 1975.
- [8] Shampine, L. F. and M. E. Hosea, “Analysis and Implementation of TR-BDF2,” *Applied Numerical Mathematics* 20, 1996.
- [9] Shampine, L. F. and M. W. Reichelt, “The MATLAB ODE Suite,” *SIAM Journal on Scientific Computing*, Vol. 18, 1997, pp. 1–22.
- [10] Shampine, L. F., M. W. Reichelt, and J.A. Kierzenka, “Solving Index-1 DAEs in MATLAB and Simulink,” *SIAM Review*, Vol. 41, 1999, pp. 538–552.

## See Also

`deval` | `ode15i` | `odeget` | `odeset` | `function_handle`

**Purpose** Ordinary differential equation options parameters

**Syntax**

```
o = odeget(options,'name')
o = odeget(options,'name',default)
```

**Description** `o = odeget(options,'name')` extracts the value of the property specified by string 'name' from integrator options structure `options`, returning an empty matrix if the property value is not specified in `options`. It is only necessary to type the leading characters that uniquely identify the property name. Case is ignored for property names.

`o = odeget(options,'name',default)` returns `o = default` if the named property is not specified in `options`.

The empty matrix `[]` is a valid `options` argument, and the syntax `odeget([], 'name', default)` always returns `default`.

## Examples

Having constructed an ODE options structure,

```
options = odeset('RelTol',1e-4,'AbsTol',[1e-3 2e-3 3e-3]);
```

you can view these property settings with `odeget`.

```
odeget(options,'RelTol')
ans =
```

```
1.0000e-04
```

```
odeget(options,'AbsTol')
ans =
```

```
0.0010 0.0020 0.0030
```

```
odeget([], 'RelTol',1e-3)
ans =
```

```
1.0000e-03
```

# odeget

---

## See Also

[odeset](#)



**Purpose**

Create or alter options structure for ordinary differential equation solvers

**Syntax**

```
options = odeset('name1',value1,'name2',value2,...)
options = odeset(olddopts,'name1',value1,...)
options = odeset(olddopts,newopts)
odeset
```

**Description**

The `odeset` function lets you adjust the integration parameters of the following ODE solvers.

For solving fully implicit differential equations:

```
ode15i
```

For solving initial value problems:

```
ode23, ode45, ode113, ode15s, ode23s, ode23t, ode23tb
```

See below for information about the integration parameters.

`options = odeset('name1',value1,'name2',value2,...)` creates an options structure that you can pass as an argument to any of the ODE solvers. In the resulting structure, `options`, the named properties have the specified values. For example, `'name1'` has the value `value1`. Any unspecified properties have default values. It is sufficient to type only the leading characters that uniquely identify a property name. Case is ignored for property names.

`options = odeset(olddopts,'name1',value1,...)` alters an existing options structure `olddopts`. This sets `options` equal to the existing structure `olddopts`, overwrites any values in `olddopts` that are respecified using name/value pairs, and adds any new pairs to the structure. The modified structure is returned as an output argument.

`options = odeset(olddopts,newopts)` alters an existing options structure `olddopts` by combining it with a new options structure `newopts`. Any new options not equal to the empty matrix overwrite corresponding options in `olddopts`.

odeset with no input arguments displays all property names as well as their possible and default values.

## ODE Properties

The following sections describe the properties that you can set using odeset. The available properties depend on the ODE solver you are using. There are several categories of properties:

- “Error Control Properties” on page 1-4792
- “Solver Output Properties” on page 1-4794
- “Step-Size Properties” on page 1-4797
- “Event Location Property” on page 1-4799
- “Jacobian Matrix Properties” on page 1-4800
- “Mass Matrix and DAE Properties” on page 1-4804
- “ode15s and ode15i-Specific Properties” on page 1-4806

---

**Note** This reference page describes the ODE properties for MATLAB, Version 7. The Version 5 properties are supported only for backward compatibility. For information on the Version 5 properties, type at the MATLAB command line: `more on`, type `odeset`, `more off`.

---

## Error Control Properties

At each step, the solver estimates the local error  $e$  in the  $i$ th component of the solution. This error must be less than or equal to the acceptable error, which is a function of the specified relative tolerance, `RelTol`, and the specified absolute tolerance, `AbsTol`.

$$|e(i)| \leq \max(\text{RelTol} * \text{abs}(y(i)), \text{AbsTol}(i))$$

For routine problems, the ODE solvers deliver accuracy roughly equivalent to the accuracy you request. They deliver less accuracy for problems integrated over "long" intervals and problems that are moderately unstable. Difficult problems may require tighter tolerances than the default values. For relative accuracy, adjust `RelTol`. For

the absolute error tolerance, the scaling of the solution components is important: if  $|y|$  is somewhat smaller than `AbsTol`, the solver is not constrained to obtain any correct digits in  $y$ . You might have to solve a problem more than once to discover the scale of solution components.

Roughly speaking, this means that you want `RelTol` correct digits in all solution components except those smaller than thresholds `AbsTol(i)`. Even if you are not interested in a component  $y(i)$  when it is small, you may have to specify `AbsTol(i)` small enough to get some correct digits in  $y(i)$  so that you can accurately compute more interesting components.

The following table describes the error control properties. Further information on each property is given following the table.

Property	Value	Description
<code>RelTol</code>	Positive scalar {1e-3}	Relative error tolerance that applies to all components of the solution vector $y$ .
<code>AbsTol</code>	Positive scalar or vector {1e-6}	Absolute error tolerances that apply to the individual components of the solution vector.
<code>NormControl</code>	on   {off}	Control error relative to norm of solution.

### Description of Error Control Properties

**RelTol** — This tolerance is a measure of the error relative to the size of each solution component. Roughly, it controls the number of correct digits in all solution components, except those smaller than thresholds `AbsTol(i)`.

The default, `1e-3`, corresponds to 0.1% accuracy.

**AbsTol** — `AbsTol(i)` is a threshold below which the value of the  $i$ th solution component is unimportant. The absolute error tolerances determine the accuracy when the solution approaches zero.

If `AbsTol` is a vector, the length of `AbsTol` must be the same as the length of the solution vector `y`. If `AbsTol` is a scalar, the value applies to all components of `y`.

**NormControl** — Set this property on to request that the solvers control the error in each integration step with  $\text{norm}(e) \leq \max(\text{RelTol} \cdot \text{norm}(y), \text{AbsTol})$ . By default the solvers use a more stringent componentwise error control.

## Solver Output Properties

The following table lists the solver output properties that control the output that the solvers generate. Further information on each property is given following the table.

Property	Value	Description
NonNegative	Vector of integers	Specifies which components of the solution vector must be nonnegative. The default value is <code>[]</code> .
OutputFcn	Function handle	A function for the solver to call after every successful integration step.
OutputSel	Vector of indices	Specifies which components of the solution vector are to be passed to the output function.
Refine	Positive integer	Increases the number of output points by a factor of <code>Refine</code> .
Stats	on   {off}	Determines whether the solver should display statistics about its computations. By default, <code>Stats</code> is off.

### Description of Solver Output Properties

**NonNegative** — The `NonNegative` property is not available in `ode23s`, `ode15i`. In `ode15s`, `ode23t`, and `ode23tb`, `NonNegative` is not available for problems where there is a mass matrix.

**OutputFcn** — To specify an output function, set 'OutputFcn' to a function handle. For example,

```
options = odeset('OutputFcn',@myfun)
```

sets 'OutputFcn' to @myfun, a handle to the function myfun. See the `function_handle` reference page for more information.

The output function must be of the form

```
status = myfun(t,y,flag)
```

“Parameterizing Functions” explains how to provide additional parameters to myfun, if necessary.

The solver calls the specified output function with the following flags. Note that the syntax of the call differs with the flag. The function must respond appropriately:

Flag	Description
init	The solver calls <code>myfun(tspan,y0,'init')</code> before beginning the integration to allow the output function to initialize. <code>tspan</code> and <code>y0</code> are the input arguments to the ODE solver.
{[]}	The solver calls <code>status = myfun(t,y,[])</code> after each integration step on which output is requested. <code>t</code> contains points where output was generated during the step, and <code>y</code> is the numerical solution at the points in <code>t</code> . If <code>t</code> is a vector, the <i>i</i> th column of <code>y</code> corresponds to the <i>i</i> th element of <code>t</code> .  When <code>length(tspan) &gt; 2</code> the output is produced at every point in <code>tspan</code> . When <code>length(tspan) = 2</code> the output is produced according to the <code>Refine</code> option.

Flag	Description
	myfun must return a status output value of 0 or 1. If status = 1, the solver halts integration. You can use this mechanism, for instance, to implement a <b>Stop</b> button.
done	The solver calls myfun([],[], 'done') when integration is complete to allow the output function to perform any cleanup chores.

You can use these general purpose output functions or you can edit them to create your own. Type `help function` at the command line for more information.

- `odeplot` — Time series plotting (default when you call the solver with no output arguments and you have not specified an output function)
- `odephas2` — Two-dimensional phase plane plotting
- `odephas3` — Three-dimensional phase plane plotting
- `odeprint` — Print solution as it is computed

---

**Note** If you call the solver with no output arguments, the solver does not allocate storage to hold the entire solution history.

---

**OutputSel** — Use `OutputSel` to specify which components of the solution vector you want passed to the output function. For example, if you want to use the `odeplot` output function, but you want to plot only the first and third components of the solution, you can do this using

```
options = ...
odeset('OutputFcn',@odeplot,'OutputSel',[1 3]);
```

By default, the solver passes all components of the solution to the output function.

**Refine** — If `Refine` is 1, the solver returns solutions only at the end of each time step. If `Refine` is  $n > 1$ , the solver subdivides each time step into  $n$  smaller intervals and returns solutions at each time point. `Refine` does not apply when `length(tspan) > 2` or the ODE solver returns the solution as a structure.

---

**Note** In all the solvers, the default value of `Refine` is 1. Within `ode45`, however, the default is 4 to compensate for the solver's large step sizes. To override this and see only the time steps chosen by `ode45`, set `Refine` to 1.

---

The extra values produced for `Refine` are computed by means of continuous extension formulas. These are specialized formulas used by the ODE solvers to obtain accurate solutions between computed time steps without significant increase in computation time.

**Stats** — By default, `Stats` is off. If it is on, after solving the problem the solver displays

- Number of successful steps
- Number of failed attempts
- Number of times the ODE function was called to evaluate  $f(t,y)$

Solvers based on implicit methods, including `ode23s`, `ode23t`, `ode15s`, and `ode15i`, also display

- Number of times that the partial derivatives matrix  $\partial f/\partial x$  was formed
- Number of LU decompositions
- Number of solutions of linear systems

## Step-Size Properties

The step-size properties specify the size of the first step the solver tries, potentially helping it to better recognize the scale of the problem. In addition, you can specify bounds on the sizes of subsequent time steps.

The following table describes the step-size properties. Further information on each property is given following the table.

Property	Value	Description
InitialStep	Positive scalar	Suggested initial step size.
MaxStep	Positive scalar {0.1*abs(t0-tf)}	Upper bound on solver step size.

### Description of Step-Size Properties

**InitialStep** — InitialStep sets an upper bound on the magnitude of the first step size the solver tries. If you do not set InitialStep, the initial step size is based on the slope of the solution at the initial time `tspan(1)`, and if the slope of all solution components is zero, the procedure might try a step size that is much too large. If you know this is happening or you want to be sure that the solver resolves important behavior at the start of the integration, help the code start by providing a suitable InitialStep.

**MaxStep** — If the differential equation has periodic coefficients or solutions, it might be a good idea to set MaxStep to some fraction (such as 1/4) of the period. This guarantees that the solver does not enlarge the time step too much and step over a period of interest. Do *not* reduce MaxStep for any of the following purposes:

- To produce more output points. This can significantly slow down solution time. Instead, use `Refine` to compute additional outputs by continuous extension at very low cost.
- When the solution does not appear to be accurate enough. Instead, reduce the relative error tolerance `RelTol`, and use the solution you just computed to determine appropriate values for the absolute error tolerance vector `AbsTol`. See “Error Control Properties” on page 1-4792 for a description of the error tolerance properties.
- To make sure that the solver doesn’t step over some behavior that occurs only once during the simulation interval. If you know the time at which the change occurs, break the simulation interval into



two pieces and call the solver twice. If you do not know the time at which the change occurs, try reducing the error tolerances `RelTol` and `AbsTol`. Use `MaxStep` as a last resort.

## Event Location Property

In some ODE problems the times of specific events are important, such as the time at which a ball hits the ground, or the time at which a spaceship returns to the earth. While solving a problem, the ODE solvers can detect such events by locating transitions to, from, or through zeros of user-defined functions.

The following table describes the `Events` property. Further information on each property is given following the table.

### ODE Events Property

String	Value	Description
Events	Function handle	Handle to a function that includes one or more event functions.

### Description of Event Location Properties

**Events** — The function is of the form

```
[value, isterminal, direction] = events(t,y)
```

`value`, `isterminal`, and `direction` are vectors for which the `i`th element corresponds to the `i`th event function:

- `value(i)` is the value of the `i`th event function.
- `isterminal(i) = 1` if the integration is to terminate at a zero of this event function, otherwise, 0.
- `direction(i) = 0` if all zeros are to be located (the default), +1 if only zeros where the event function is increasing, and -1 if only zeros where the event function is decreasing.

If you specify an events function and events are detected, the solver returns three additional outputs:

- A column vector of times at which events occur
- Solution values corresponding to these times
- Indices into the vector returned by the events function. The values indicate which event the solver detected.

If you call the solver as

```
[T,Y,TE,YE,IE] = solver(odefun,tspan,y0,options)
```

the solver returns these outputs as TE, YE, and IE respectively. If you call the solver as

```
sol = solver(odefun,tspan,y0,options)
```

the solver returns these outputs as sol.xe, sol.ye, and sol.ie, respectively.

For examples that use an event function, see “Event Location” and “Advanced Event Location” in the MATLAB Mathematics documentation.

## Jacobian Matrix Properties

The stiff ODE solvers often execute faster if you provide additional information about the Jacobian matrix  $\partial f/\partial y$ , a matrix of partial derivatives of the function that defines the differential equations.

$$\frac{\partial f}{\partial y} = \begin{bmatrix} \frac{\partial f_1}{\partial y_1} & \frac{\partial f_1}{\partial y_2} & \dots \\ \frac{\partial f_2}{\partial y_1} & \frac{\partial f_2}{\partial y_2} & \dots \\ \vdots & \vdots & \ddots \end{bmatrix}$$

The Jacobian matrix properties pertain only to those solvers for stiff problems (`ode15s`, `ode23s`, `ode23t`, `ode23tb`, and `ode15i`) for which the Jacobian matrix  $\partial f/\partial y$  can be critical to reliability and efficiency. If you do not provide a function to calculate the Jacobian, these solvers

approximate the Jacobian numerically using finite differences. In this case, you might want to use the `Vectorized` or `JPattern` properties.

The following table describes the Jacobian matrix properties for all implicit solvers except `ode15i`. Further information on each property is given following the table. See [Jacobian Properties for `ode15i`](#) on page 1-4803 for `ode15i`-specific information.

### Jacobian Properties for All Implicit Solvers Except `ode15i`

Property	Value	Description
Jacobian	Function handle   constant matrix	Matrix or function that evaluates the Jacobian.
JPattern	Sparse matrix of {0,1}	Generates a sparse Jacobian matrix numerically.
Vectorized	on   {off}	Allows the solver to reduce the number of function evaluations required.

### Description of Jacobian Properties

**Jacobian** — Supplying an analytical Jacobian often increases the speed and reliability of the solution for stiff problems. Set this property to a function `FJac`, where `FJac(t,y)` computes  $\partial f/\partial y$ , or to the constant value of  $\partial f/\partial y$ .

The Jacobian for the “van der Pol Equation (Stiff)”, described in the MATLAB Mathematics documentation, can be coded as

```
function J = vdp1000jac(t,y)
J = [0 1
 (-2000*y(1)*y(2)-1) (1000*(1-y(1)^2))];
```

**JPattern** — `JPattern` is a sparsity pattern with 1s where there might be nonzero entries in the Jacobian.

---

**Note** If you specify **Jacobian**, the solver ignores any setting for **JPattern**.

---

Set this property to a sparse matrix  $S$  with  $S(i,j) = 1$  if component  $i$  of  $f(t,y)$  depends on component  $j$  of  $y$ , and 0 otherwise. The solver uses this sparsity pattern to generate a sparse Jacobian matrix numerically. If the Jacobian matrix is large and sparse, this can greatly accelerate execution. For an example using the **JPattern** property, see [Example: Large, Stiff, Sparse Problem](#) in the MATLAB Mathematics documentation.

**Vectorized** — The **Vectorized** property allows the solver to reduce the number of function evaluations required to compute all the columns of the Jacobian matrix, and might significantly reduce solution time.

Set on to inform the solver that you have coded the ODE function  $F$  so that  $F(t, [y1\ y2\ \dots])$  returns  $[F(t,y1)\ F(t,y2)\ \dots]$ . This allows the solver to reduce the number of function evaluations required to compute all the columns of the Jacobian matrix, and might significantly reduce solution time.

---

**Note** If you specify **Jacobian**, the solver ignores a setting of 'on' for 'Vectorized'.

---

With the MATLAB array notation, it is typically an easy matter to vectorize an ODE function. For example, you can vectorize the “van der Pol Equation (Stiff)”, described in the MATLAB Mathematics documentation, by introducing colon notation into the subscripts and by using the array power ( $\wedge$ ) and array multiplication ( $\cdot$ ) operators.

```
function dydt = vdp1000(t,y)
dydt = [y(2,:); 1000*(1-y(1,:)).^2).*y(2,:)-y(1,:)];
```

---

**Note** Vectorization of the ODE function used by the ODE solvers differs from the vectorization used by the boundary value problem (BVP) solver, `bvp4c`. For the ODE solvers, the ODE function is vectorized only with respect to the second argument, while `bvp4c` requires vectorization with respect to the first and second arguments.

---

The following table describes the Jacobian matrix properties for `ode15i`.

### Jacobian Properties for `ode15i`

Property	Value	Description
Jacobian	Function handle   Cell array of constant values	Function that evaluates the Jacobian or a cell array of constant values.
JPattern	Sparse matrices of {0,1}	Generates a sparse Jacobian matrix numerically.
Vectorized	on   {off}	Vectorized ODE function

### Description of Jacobian Properties for `ode15i`

**Jacobian** — Supplying an analytical Jacobian often increases the speed and reliability of the solution for stiff problems. Set this property to a function

$$[dFd_y, dFd_p] = Fjac(t, y, y_p)$$

or to a cell array of constant values  $[\partial F/\partial y, (\partial F/\partial y)']$ .

**JPattern** — `JPattern` is a sparsity pattern with 1's where there might be nonzero entries in the Jacobian.

Set this property to  $\{dFd_yPattern, dFd_y_pPattern\}$ , the sparsity patterns of  $\partial F/\partial y$  and  $\partial F/\partial y'$ , respectively.

**Vectorized** —

Set this property to {yVect, ypVect}. Setting yVect to 'on' indicates that

```
F(t, [y1 y2 ...], yp)
```

returns

```
[F(t,y1,yp), F(t,y2,yp) ...]
```

Setting ypVect to 'on' indicates that

```
F(t,y,[yp1 yp2 ...])
```

returns

```
[F(t,y,yp1) F(t,y,yp2) ...]
```

## Mass Matrix and DAE Properties

This section describes mass matrix and differential-algebraic equation (DAE) properties, which apply to all the solvers except `ode15i`. These properties are not applicable to `ode15i` and their settings do not affect its behavior.

The solvers of the ODE suite can solve ODEs of the form

$$M(t,y)y' = f(t,y) \tag{1-3}$$

with a mass matrix  $M(t,y)$  that can be sparse.

When  $M(t,y)$  is nonsingular, the equation above is equivalent to  $y' = M^{-1}f(t,y)$  and the ODE has a solution for any initial values  $y_0$  at  $t_0$ . The more general form (Equation 1-3) is convenient when you express a model naturally in terms of a mass matrix. For large, sparse  $M(t,y)$ , solving Equation 1-3 directly reduces the storage and run-time needed to solve the problem.

When  $M(t,y)$  is singular, then  $M(t,y)$  times  $M(t,y)y' = f(t,y)$  is a DAE. A DAE has a solution only when  $y_0$  is consistent; that is, there exists an initial slope  $yp_0$  such that  $M(t_0,y_0)yp_0 = f(t_0,y_0)$ . If  $y_0$  and  $yp_0$  are not consistent, the solver treats them as guesses, attempts to compute consistent values that are close to the guesses, and continues to solve

the problem. For DAEs of index 1, solving an initial value problem with consistent initial conditions is much like solving an ODE.

The `ode15s` and `ode23t` solvers can solve DAEs of index 1. For examples of DAE problems, see Example: Differential-Algebraic Problem, in the MATLAB Mathematics documentation, and the examples `amp1dae` and `hb1dae`.

The following table describes the mass matrix and DAE properties. Further information on each property is given following the table.

### Mass Matrix and DAE Properties (Solvers Other Than `ode15i`)

Property	Value	Description
Mass	Matrix   function handle	Mass matrix or a function that evaluates the mass matrix $M(t,y)$ .
MStateDependence	none   {weak}   strong	Dependence of the mass matrix on $y$ .
MvPattern	Sparse matrix	$\partial(M(t,y)v)/\partial y$ sparsity pattern.
MassSingular	yes   no   {maybe}	Indicates whether the mass matrix is singular.
InitialSlope	Vector {zero vector}	Vector representing the consistent initial slope $yp_0$ .

### Description of Mass Matrix and DAE Properties

**Mass** — For problems of the form  $M(t)y' = f(t,y)$ , set 'Mass' to a mass matrix  $M$ . For problems of the form  $M(t)y' = f(t,y)$ , set 'Mass' to a function handle `@Mfun`, where `Mfun(t,y)` evaluates the mass matrix  $M(t,y)$ . The `ode23s` solver can only solve problems with a constant mass matrix  $M$ . When solving DAEs, using `ode15s` or `ode23t`, it is advantageous to formulate the problem so that  $M$  is a diagonal matrix (a semiexplicit DAE).

For example problems, see “Finite Element Discretization” in the MATLAB Mathematics documentation, or the examples `fem2ode` or `batonode`.

**MStateDependence** — Set this property to `none` for problems

$M(t)y' = f(t,y)$ . Both `weak` and `strong` indicate  $M(t,y)$ , but `weak` results in implicit solvers using approximations when solving algebraic equations.

**MvPattern** — Set this property to a sparse matrix  $S$  with  $S(i,j) = 1$  if, for any  $k$ , the  $(i,k)$  component of  $M(t,y)$  depends on component  $j$  of  $y$ , and 0 otherwise. For use with the `ode15s`, `ode23t`, and `ode23tb` solvers when `MStateDependence` is `strong`. See `burgersode` as an example.

**MassSingular** — Set this property to `no` if the mass matrix is not singular and you are using either the `ode15s` or `ode23t` solver. The default value of `maybe` causes the solver to test whether the problem is a DAE, by testing whether  $M(t_0,y_0)$  is singular.

**InitialSlope** — Vector representing the consistent initial slope  $yp_0$ , where  $yp_0$  satisfies  $M(t_0,y_0) \cdot yp_0 = f(t_0,y_0)$ . The default is the zero vector.

This property is for use with the `ode15s` and `ode23t` solvers when solving DAEs.

## ode15s and ode15i-Specific Properties

`ode15s` is a variable-order solver for stiff problems. It is based on the numerical differentiation formulas (NDFs). The NDFs are generally more efficient than the closely related family of backward differentiation formulas (BDFs), also known as Gear’s methods. The `ode15s` properties let you choose among these formulas, as well as specifying the maximum order for the formula used.

`ode15i` solves fully implicit differential equations of the form

$$f(t,y,y') = 0$$

using the variable order BDF method.



The following table describes the `ode15s` and `ode15i`-specific properties. Further information on each property is given following the table. Use `odeset` to set these properties.

### ode15s and ode15i-Specific Properties

Property	Value	Description
MaxOrder	1   2   3   4   {5}	Maximum order formula used to compute the solution.
BDF (ode15s only)	on   {off}	Specifies whether you want to use the BDFs instead of the default NDFs.

### Description of ode15s and ode15i-Specific Properties

**MaxOrder** — Maximum order formula used to compute the solution.

**BDF** (ode15s only) — Set BDF on to have `ode15s` use the BDFs.

For both the NDFs and BDFs, the formulas of orders 1 and 2 are A-stable (the stability region includes the entire left half complex plane). The higher order formulas are not as stable, and the higher the order the worse the stability. There is a class of stiff problems (stiff oscillatory) that is solved more efficiently if `MaxOrder` is reduced (for example to 2) so that only the most stable formulas are used.

### See Also

`deval` | `odeget` | `ode45` | `ode23` | `ode23t` | `ode23tb` | `ode113` | `ode15s` | `ode23s` | `function_handle`

# odextend

---

## Purpose

Extend solution of initial value problem for ordinary differential equation

## Syntax

```
solext = odextend(sol, odefun, tfinal)
solext = odextend(sol,[],tfinal)
solext = odextend(sol, odefun, tfinal, yinit)
solext = odextend(sol, odefun, tfinal, [yinit, ypinit])
solext = odextend(sol, odefun, tfinal, yinit, options)
```

## Description

`solext = odextend(sol, odefun, tfinal)` extends the solution stored in `sol` to an interval with upper bound `tfinal` for the independent variable. Specify `odefun` as a function handle. Specify `sol` as an ODE solution structure created using an ODE solver. The lower bound for the independent variable in `solext` is the same as in `sol`. If you created `sol` with an ODE solver other than `ode15i`, the function `odefun` computes the right-hand side of the ODE equation, which is of the form  $y' = f(t,y)$ . If you created `sol` using `ode15i`, the function `odefun` computes the left-hand side of the ODE equation, which is of the form  $f(t,y,y') = 0$ .

“Parameterizing Functions” explains how to provide additional parameters to the function `odefun`, if necessary.

`odextend` extends the solution by integrating `odefun` from the upper bound for the independent variable in `sol` to `tfinal`, using the same ODE solver that created `sol`. By default, `odextend` uses

- The initial conditions `y = sol.y(:,end)` for the subsequent integration
- The same integration properties and additional input arguments the ODE solver originally used to compute `sol`. This information is stored as part of the solution structure `sol` and is subsequently passed to `solext`. Unless you want to change these values, you do not need to pass them to `odextend`.

`solext = odextend(sol,[],tfinal)` uses the same ODE function that the ODE solver uses to compute `sol` to extend the solution. It is

not necessary to pass in `odefun` explicitly unless it differs from the original ODE function.

`solx = odextend(sol, odefun, tfinal, yinit)` uses the column vector `yinit` as new initial conditions for the subsequent integration, instead of the vector `sol.y(end)`.

---

**Note** To extend solutions obtained with `ode15i`, use the following syntax, in which the column vector `ypinit` is the initial derivative of the solution:

---

```
solx = odextend(sol, odefun, tfinal, [yinit, ypinit])
```

---

`solx = odextend(sol, odefun, tfinal, yinit, options)` uses the integration properties specified in `options` instead of the options the ODE solver originally used to compute `sol`. The new options are then stored within the structure `solx`. See `odeset` for details on setting options properties. Set `yinit = []` as a placeholder to specify the default initial conditions.

## Examples

The following command

```
sol=ode45(@vdp1,[0 10],[2 0]);
```

uses `ode45` to solve the system  $y' = \text{vdp1}(t, y)$ , where `vdp1` is an example of an ODE function provided with MATLAB software, on the interval `[0 10]`. Then, the commands

```
sol=odextend(sol,@vdp1,20);
plot(sol.x,sol.y(1,:));
```

extend the solution to the interval `[0 20]` and plot the first component of the solution on `[0 20]`.

## See Also

[deval](#) | [ode23](#) | [ode45](#) | [ode113](#) | [ode15s](#) | [ode23s](#) | [ode23t](#) | [ode23tb](#) | [ode15i](#) | [odeset](#) | [odeget](#) | [deval](#) | [function\\_handle](#)

# onCleanup

---

**Purpose** Cleanup tasks upon function completion

**Syntax** `cleanupObj = onCleanup(cleanupFun)`

**Description** `cleanupObj = onCleanup(cleanupFun)` creates an object that, when destroyed, executes the function `cleanupFun`. MATLAB implicitly clears all local variables at the termination of a function, whether by normal completion, or a forced exit, such as an error, or **Ctrl+C**.

If you reference or pass `cleanupObj` outside your function, then `cleanupFun` does not run when that function terminates. Instead, it runs whenever the MATLAB destroys the object.

## Input Arguments

### **cleanupFun - Clean-up task**

function handle

Clean-up task, specified as a handle to a function.

You can declare any number of `onCleanup` objects in a program file. However, if the clean-up tasks depend on the order of execution, then you should define only one object that calls a script or function, containing the relevant clean-up commands.

You should use an anonymous function handle to call your clean-up task. This allows you to pass arguments to your clean-up function.

**Example:** `@() fclose('file.m')`

**Example:** `@() user_script`

**Example:** `@() function(input)`

### **Data Types**

function\_handle

## Examples

### **Close a Figure After Executing Function**

Save the following code in `action.m` and type `action` in the Command Window.

```
function [] = action()
```

```
f = figure;
finishup = onCleanup(@() myCleanupFun(f));
disp('Display Figure');
end
```

```
function myCleanupFun(f)
close(f);
disp('Close Figure')
end
```

```
Display Figure
Close Figure
```

### Switch Directories After Executing Function

Pass your own script to the `onCleanup` object so that it executes when MATLAB destroys the cleanup object.

Save the following code in `cleanup.m`.

```
cd(tempdir);
disp('You are now in the temporary folder')
```

Save the following code in `youraction.m` and type `youraction` in the Command Window.

```
function [] = youraction
changeup = onCleanup(@cleanup);
disp('Execute Code');
end
```

```
Execute Code
You are now in the temporary folder
```

## Tips

- Avoid using nested functions during cleanup. MATLAB can clear variables used in nested functions before the clean-up function tries to read from them.
- If your program contains multiple cleanup objects, MATLAB does not guarantee the order that it destroys these objects.

# onCleanup

---

- If the order of your cleanup functions matters, define one `onCleanup` object for all the tasks.

## See Also

`clear` | `clearvars` | `function_handle`

## Concepts

- “Clean Up When Functions Complete”
- “Object Lifecycle”
- “Function Handles”
- “What Are Anonymous Functions?”

**Purpose**

Create array of all ones

**Syntax**

```
X = ones
X = ones(n)
X = ones(sz1, ..., szN)
X = ones(sz)

X = ones(classname)
X = ones(n, classname)
X = ones(sz1, ..., szN, classname)
X = ones(sz, classname)

X = ones('like', p)
X = ones(n, 'like', p)
X = ones(sz1, ..., szN, 'like', p)
X = ones(sz, 'like', p)
```

**Description**

`X = ones` returns the scalar 1.

`X = ones(n)` returns an n-by-n matrix of ones.

`X = ones(sz1, ..., szN)` returns an sz1-by-...-by-szN array of ones where sz1, ..., szN indicates the size of each dimension. For example, `ones(2,3)` returns a 2-by-3 array of ones.

`X = ones(sz)` returns an array of ones where the size vector, `sz`, defines `size(X)`. For example, `ones([2,3])` returns a 2-by-3 array of ones.

`X = ones(classname)` returns a scalar 1 where the string, `classname`, specifies the data type. For example, `ones('int8')` returns a scalar, 8-bit integer 1.

`X = ones(n, classname)` returns an n-by-n array of ones of data type `classname`.

`X = ones(sz1, ..., szN, classname)` returns an `sz1`-by-...-by-`szN` array of ones of data type `classname`.

`X = ones(sz, classname)` returns an array of ones where the size vector, `sz`, defines `size(X)` and `classname` defines `class(X)`.

`X = ones('like', p)` returns a scalar 1 with the same data type, sparsity, and complexity (real or complex) as the numeric variable, `p`.

`X = ones(n, 'like', p)` returns an `n`-by-`n` array of ones like `p`.

`X = ones(sz1, ..., szN, 'like', p)` returns an `sz1`-by-...-by-`szN` array of ones like `p`.

`X = ones(sz, 'like', p)` returns an array of ones like `p` where the size vector, `sz`, defines `size(X)`.

## Input Arguments

### **n - Size of square matrix**

integer value

Size of square matrix, specified as an integer value, defines the output as a square, `n`-by-`n` matrix of ones.

- If `n` is 0, then `X` is an empty matrix.
- If `n` is negative, then it is treated as 0.

### **Data Types**

double | single | int8 | int16 | int32 | int64 | uint8 |  
uint16 | uint32 | uint64

### **sz1,...,szN - Size of each dimension**

two or more integer values

Size of each dimension, specified as two or more integer values, defines `X` as a `sz1`-by-...-by-`szN` array.



- If the size of any dimension is 0, then X is an empty array.
- If the size of any dimension is negative, then it is treated as 0.
- If any trailing dimensions greater than 2 have a size of 1, then the output, X, does not include those dimensions.

**Data Types**

double | single | int8 | int16 | int32 | int64 | uint8 |  
uint16 | uint32 | uint64

**sz - Output size**

row vector of integer values

Output size, specified as a row vector of integer values. Each element of this vector indicates the size of the corresponding dimension.

- If the size of any dimension is 0, then X is an empty array.
- If the size of any dimension is negative, then it is treated as 0.
- If any trailing dimensions greater than 2 have a size of 1, then the output, X, does not include those dimensions.

**Example:** `sz = [2,3,4]` defines X as a 2-by-3-by-4 array.

**Data Types**

double | single | int8 | int16 | int32 | int64 | uint8 |  
uint16 | uint32 | uint64

**classname - Output class**

'double' (default) | 'single' | 'int8' | 'uint8' | ...

Output class, specified as 'double', 'single', 'int8', 'uint8', 'int16', 'uint16', 'int32', 'uint32', 'int64', or 'uint64'.

**Data Types**

char

**p - Prototype**

numeric variable

Prototype, specified as a numeric variable.

## Data Types

single | double | int8 | int16 | int32 | int64 | uint8 |  
uint16 | uint32 | uint64

**Complex Number Support:** Yes

## Examples

### Square Array of Ones

Create a 4-by-4 array of ones.

```
X = ones(4)
```

```
X =
```

```
 1 1 1 1
 1 1 1 1
 1 1 1 1
 1 1 1 1
```

### 3-D Array of Ones

Create a 2-by-3-by-4 array of ones.

```
X = ones(2,3,4);
```

```
size(X)
```

```
ans =
```

```
 2 3 4
```

### Size Defined by Existing Array

Define a 3-by-2 array A.

```
A = [1 4 ; 2 5 ; 3 6];
```

```
sz = size(A)
```

```
sz =

 3 2
```

Create an array of ones that is the same size as A

```
X = ones(sz)
```

```
X =

 1 1
 1 1
 1 1
```

### Nondefault Numeric Data Type

Create a 1-by-3 vector of ones whose elements are 16-bit unsigned integers.

```
X = ones(1,3,'uint16'),
class(X)
```

```
X =

 1 1 1
```

```
ans =
```

```
uint16
```

### Complex One

Create a scalar 1 that is not real valued, but instead is complex like an existing array.

Define a complex vector.

```
p = [1+2i 3i];
```

Create a scalar 1 that is complex like p.

```
X = ones('like',p)
```

```
X =
```

```
1.0000 + 0.0000i
```

## Size and Numeric Data Type of Defined by Existing Array

Define a 2-by-3 array of 8-bit unsigned integers.

```
p = uint8([1 3 5 ; 2 4 6]);
```

Create an array of ones that is the same size and data type as p.

```
X = ones(size(p),'like',p),
class(X)
```

```
X =
```

```
1 1 1
1 1 1
```

```
ans =
```

```
uint8
```

## See Also

[eye](#) | [zeros](#) | [rand](#) | [randn](#) | [complex](#) | [false](#) | [size](#)

## Concepts

- “Class Support for Array-Creation Functions”
- “Preallocating Arrays”

---

<b>Purpose</b>	Open file in appropriate application
<b>Syntax</b>	<code>open(name)</code> <code>output = open(name)</code>
<b>Description</b>	<p><code>open(name)</code> opens the specified file or variable in the appropriate application.</p> <p><code>output = open(name)</code> returns an empty <code>output</code> (<code>[]</code>) for most cases. If opening a MAT-file, <code>output</code> is a structure that contains the variables in the file. If opening a figure, <code>output</code> is a handle to that figure.</p>
<b>Tips</b>	<p>The <code>open</code> function opens files based on their extension. You can extend the functionality of <code>open</code> by defining your own file handling function of the form <code>openxxx</code>, where <code>xxx</code> is a file extension. For example, if you create a function <code>openlog</code>, the <code>open</code> function calls <code>openlog</code> to process any files with the <code>.log</code> extension. The <code>open</code> function returns any single <code>output</code> defined by your function.</p>
<b>Input Arguments</b>	<p><b>name</b></p> <p>Name of file or variable to open. If <code>name</code> does not include an extension, the <code>open</code> function:</p> <ol style="list-style-type: none"><li>1 Searches for a variable named <code>name</code>. If the variable exists, <code>open</code> opens it in the Variables editor.</li><li>2 Searches the MATLAB path for <code>name.mdl</code>, <code>name.slx</code>, or <code>name.m</code>. If <code>name.mdl</code> or <code>name.slx</code> exists, then <code>open</code> opens the model in Simulink. If only <code>name.m</code> exists, <code>open</code> opens the file in the MATLAB Editor.</li></ol> <p>If more than one file named <code>name</code> exists on the MATLAB path, the <code>open</code> function opens the file returned by <code>which(name)</code>.</p> <p>The <code>open</code> function performs the following actions based on the file extension:</p>

## (Continued)

.m	Open in MATLAB Editor.
.mat	Return variables in structure <i>st</i> when called with the syntax:  <i>st</i> = open( <i>name</i> )
.fig	Open figure in Handle Graphics.
.mdl or .slx	Open model in Simulink.
.prj	Open project in the MATLAB Compiler Deployment Tool.
.doc*	Open document in Microsoft Word.
.exe	Run executable file (only on Windows systems).
.pdf	Open document in Adobe® Acrobat®.
.ppt*	Open document in Microsoft PowerPoint.
.xls*	Start MATLAB Import Wizard.
.htm or .html	Open document in MATLAB browser.
.url	Open file in your default Web browser.

## Examples

Open Contents.m in the MATLAB Editor by typing:

```
open Contents.m
```

Generally, MATLAB opens `matlabroot\toolbox\matlab\general\Contents.m`. However, if you have a file called `Contents.m` in a directory that is before `toolbox\matlab\general` on the MATLAB path, then `open` opens that file instead.

---

Open a file not on the MATLAB path by including the complete file specification:

```
open('D:\temp\data.mat')
```

If the file does not exist, MATLAB displays an error message.

---

Create a function called `opentxt` to handle files with extension `.txt`:

```
function opentxt(filename)

 fprintf('You have requested file: %s\n', filename);

 wh = which(filename);
 if exist(filename, 'file') == 2
 fprintf('Opening in MATLAB Editor: %s\n', filename);
 edit(filename);
 elseif ~isempty(wh)
 fprintf('Opening in MATLAB Editor: %s\n', wh);
 edit(wh);
 else
 warning('MATLAB:fileNotFound', ...
 'File was not found: %s', filename);
 end

end
```

Open the file `ngc6543a.txt` (a description of `ngc6543a.jpg`, located in `matlabroot\toolbox\matlab\demos`):

```
photo_text = 'ngc6543a.txt';
open(photo_text)
```

`open` calls your function with the following syntax:

```
opentxt(photo_text)
```

## See Also

`edit` | `load` | `openfig` | `openvar` | `path` | `uiopen` | `which` | `winopen`

# VideoWriter.open

---

<b>Purpose</b>	Open file for writing video data
<b>Syntax</b>	<code>open(writerObj)</code>
<b>Description</b>	<code>open(writerObj)</code> opens the file associated with <code>writerObj</code> for writing. When you open the file, all properties of the object become read only. <code>open</code> discards any existing contents of the file.
<b>Input Arguments</b>	<b>writerObj</b> VideoWriter object created by the <code>VideoWriter</code> function.
<b>Examples</b>	Open a new AVI file: <pre>myObj = VideoWriter('newfile.avi'); open(myObj);</pre>
<b>See Also</b>	<code>writeVideo</code>   <code>VideoWriter</code>   <code>close</code>



**Purpose** Open new copy or raise existing copy of saved figure

**Syntax**

```
openfig('filename.fig')
openfig('filename.fig','new')
openfig('filename.fig','reuse')
openfig('filename.fig','new','invisible')
openfig('filename.fig','reuse','invisible')
openfig('filename.fig','new','visible')
openfig('filename.fig','reuse','visible')
figure_handle = openfig(...)
```

**Description** `openfig('filename.fig')` and `openfig('filename.fig','new')` opens the figure contained in the FIG-file, `filename.fig`, and ensures it is visible and positioned completely on screen. You do not have to specify the full path to the FIG-file as long as it is on your MATLAB path. The `.fig` extension is optional.

`openfig('filename.fig','reuse')` opens the figure contained in the FIG-file only if a copy of the figure is not currently open. Otherwise, `openfig` brings the existing copy forward, making sure it is still visible and completely on screen.

`openfig('filename.fig','new','invisible')` or `openfig('filename.fig','reuse','invisible')` opens the figure as in the preceding example, while forcing the figure to be invisible.

`openfig('filename.fig','new','visible')` or `openfig('filename.fig','reuse','visible')` opens the figure, while forcing the figure to be visible.

`figure_handle = openfig(...)` returns the handle to the figure.

**Tips** `openfig` is designed for use with GUI figures. Use this function to:

- Open the FIG-file creating the GUI and ensure it is displayed on screen. This provides compatibility with different screen sizes and resolutions.

# openfig

---

- Control whether the MATLAB software displays one or multiple instances of the GUI at any given time.
- Return the handle of the figure created, which is typically hidden for GUI figures.

If the FIG-file contains an invisible figure, `openfig` returns its handle and leaves it invisible. The caller should make the figure visible when appropriate.

Do not use `openfig` or double-click a FIG-file to open a GUI created with GUIDE. Instead open the GUI code file by typing its name in the command window or by right-clicking its name in the Current Folder Browser and selecting **Run File**. To open a GUIDE GUI, for example one called `guifile.m`, in an invisible state, specify the `Visible` property in your command:

```
guifile('Visible','off')
```

Your code should then make the figure visible at an appropriate time.

## See Also

`guide` | `guihandles` | `movegui` | `open` | `hgload` | `save`

**Purpose** Control OpenGL rendering

**Syntax**

```
opengl selection_mode
opengl info
s = opengl('data')
opengl software
opengl hardware
opengl verbose
opengl quiet
opengl DriverBugWorkaround
opengl('DriverBugWorkaround',WorkaroundState)
```

**Description** `opengl selection_mode` determines how MATLAB selects the OpenGL renderer. Possible values for `selection_mode` are

- `autoselect` – allows OpenGL to be automatically selected if OpenGL is available and if there is graphics hardware on the host machine.
- `neverselect` – disables autoselection of OpenGL.
- `advise` – prints a message to the command window if OpenGL rendering is advised, but `RenderMode` is set to `manual`.

`opengl`, by itself, returns the current autoselection state.

Note that the autoselection state only specifies whether OpenGL should or should not be considered for rendering; it does not explicitly set the rendering to OpenGL. You can do this by setting the `Renderer` property of the figure to `OpenGL`. For example,

```
set(figure_handle, 'Renderer', 'OpenGL')
```

---

**Note** The OpenGL autoselection mode applies when the `RenderMode` of the figure is `auto`

---

`opengl info` prints information with the version and vendor of the OpenGL on your system. Also indicates whether your system is

currently using hardware or software OpenGL and the state of various driver bug workarounds. Note that calling `opengl info` loads the OpenGL Library.

For example, the following output is generated on a Windows computer:

```
>> opengl info
 Version: '3.3.0'
 Vendor: 'NVIDIA Corporation'
 Renderer: 'Quadro 400/PCI/SSE2'
MaxTextureSize: 8192
 Visual: ''
 Software: ''
 Extensions: {235x1 cell}
MaxFrameBufferSize: 8192
```

Note that different computer systems may not list all OpenGL bugs.

`s = opengl('data')` returns a structure containing the same data that is displayed when you call `opengl info`, with the exception of the driver bug workaround state.

`opengl software` forces the MATLAB software to use software OpenGL rendering instead of hardware OpenGL. Note that Macintosh systems do not support software OpenGL.

`opengl hardware` reverses the `opengl software` command and enables MATLAB to use hardware OpenGL rendering if it is available. If your computer does not have OpenGL hardware acceleration, MATLAB automatically switches to software OpenGL rendering (except on Macintosh systems, which do not support software OpenGL).

Note that on UNIX systems, the `software` or `hardware` options with the `opengl` command works only if MATLAB has not yet used the OpenGL renderer or you have not issued the `opengl info` command (which attempts to load the OpenGL Library).

`opengl verbose` displays verbose messages about OpenGL initialization (if OpenGL is not already loaded) and other runtime messages.

`opengl quiet` disables verbose message setting.

`opengl DriverBugWorkaround` queries the state of the specified driver bug workaround. Use the command `opengl info` to see a list of all driver bug workarounds. See “Driver Bug Workarounds” on page 1-4827 for more information.

`opengl('DriverBugWorkaround',WorkaroundState)` sets the state of the specified driver bug workaround. You can set `WorkaroundState` to one of three values:

- 0 – Disable the specified *DriverBugWorkaround* (if enabled) and do not allow MATLAB to autoselect this workaround.
- 1 – Enable the specified *DriverBugWorkaround*.
- -1 – Set the specified *DriverBugWorkaround* to autoselection mode, which allows MATLAB to enable this workaround if the requisite conditions exist.

## Driver Bug Workarounds

---

**Note** Always check with your graphics hardware vendor to ensure you are using the latest driver software. Use the `opengl info` command to see your current version number.

---

The MATLAB software enables various OpenGL driver bug workarounds when it detects certain known problems with installed hardware. However, because there are many versions of graphics drivers, you might encounter situations when MATLAB does not enable a workaround that would solve a problem you are having with OpenGL rendering.

This section describes the symptoms that each workaround is designed to correct so you can decide if you want to try using one to fix an OpenGL rendering problem.

Use the `opengl info` command to see what driver bug workarounds are available on your computer.

---

**Note** These workarounds have not been tested under all driver combinations and therefore might produce undesirable results under certain conditions.

---

## **OpenGLBitmapZbufferBug**

Symptom: text with background color (including data tips) and text displayed on image, patch, or surface objects is not visible when using OpenGL renderer.

Possible side effect: text is always on top of other objects.

Command to enable:

```
opengl('OpenGLBitmapZbufferBug',1)
```

## **OpenGLWobbleTesselatorBug**

Symptom: Rendering complex patch object causes segmentation violation and returns a tessellator error message in the stack trace.

Command to enable:

```
opengl('OpenGLWobbleTesselatorBug',1)
```

## **OpenGLLineSmoothingBug**

Symptom: Lines with a LineWidth greater than 3 look bad.

Command to enable:

```
opengl('OpenGLLineSmoothingBug',1)
```

## **OpenGLDockingBug**

Symptom: MATLAB crashes when you dock a figure that has its Renderer property set to opengl.

Command to enable:

```
opengl('OpenGLDockingBug',1)
```

### **OpenGLClippedImageBug**

Symptom: Images (as well as colorbar displays) do not display when the `Renderer` property set to `opengl`.

Command to enable:

```
opengl('OpenGLClippedImageBug',1)
```

### **OpenGLERaseModeBug**

Symptom: Graphics objects with `EraseMode` property set to non-normal erase modes (`xor`, `none`, or `background`) do not draw when the figure `Renderer` property is set to `opengl`.

Command to enable:

```
opengl('OpenGLERaseModeBug',1)
```

## **See Also**

`Renderer`

# openvar

---

**Purpose** Open workspace variable in Variables editor or other graphical editing tool

**Syntax** `openvar(varname)`

**Description** `openvar(varname)` opens the workspace variable named by the string, `varname`, in the Variables editor for graphical editing. Changes that you make to variables in the Variables editor occur in the workspace as soon as you enter them.

In some toolboxes, `openvar` opens a tool appropriate for viewing or editing objects indicated by `varname` instead of opening the Variables editor.

MATLAB does not impose any limitation on the size of a variable that you can open in the Variables editor. However, your operating system or the amount of physical memory installed on your computer can impose such limits.

## Input Arguments

### **varname - Variable name**

string

Variable name, specified as a string. The named variable can be an array, character string, cell array, structure, or an object and its properties. If the named variable is a multidimensional array, then you can only view the array in the Variables editor, and not edit it.

**Example:** `'myVariable'`

**Example:** `'A'`

## Examples

### **Identify Outliers in a Linked Graph**

Use data brushing to identify observations in a vector or matrix that might warrant further analysis.

Make a scatter plot of data in the sample MAT-file `count.dat`, and open the variable `count` in the Variables editor.

```
load count.dat
```





```
scatter(count(:,1),count(:,2))
openvar('count')
```

Right-click a cell in the Variables editor and select **Brushing > Brushing On**. This turns on data brushing in the Variables editor.

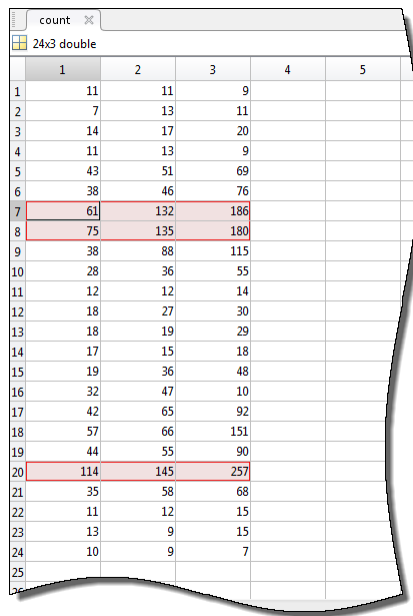
Select the rows 7, 8, and 20. (Select noncontiguous rows by holding down the **Ctrl** key and clicking in each row.)



	1	2	3	4	5
1	11	11	9		
2	7	13	11		
3	14	17	20		
4	11	13	9		
5	43	51	69		
6	38	46	76		
7	61	132	186		
8	75	135	180		
9	38	88	115		
10	28	36	55		
11	12	12	14		
12	18	27	30		
13	18	19	29		
14	17	15	18		
15	19	36	48		
16	32	47	10		
17	42	65	92		
18	57	66	151		
19	44	55	90		
20	114	145	257		
21	35	58	68		
22	11	12	15		
23	13	9	15		
24	10	9	7		
25					

In the Figure window with the scatter plot, click **Brush/Select Data**  to enable data brushing, and **Link Plot**  to enable data linking.

The data observations you brushed in the Variables editor appear highlighted in the scatter plot.

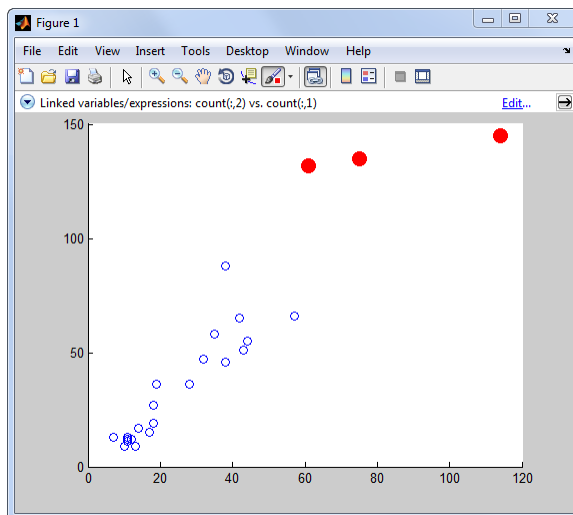

As long as data linking is enabled in the figure, observations that you brush in the scatter plot are highlighted in the Variables editor. When a figure is not linked to its data sources, you can still brush its graphs and you can brush the same data in the Variables editor, but only the display that you brush responds by highlighting.

## Tips

- As an alternative to the `openvar` function, double-click a variable in the Workspace browser.

## See Also

`brush` | `linkdata` | `load` | `workspace` | `save`

## Concepts

- “View, Edit, and Copy Variables”
- “Making Graphs Responsive with Data Linking”

---

<b>Purpose</b>	Optimization options values
<b>Syntax</b>	<pre>val = optimget(options,'param') val = optimget(options,'param',default)</pre>
<b>Description</b>	<p><code>val = optimget(options,'param')</code> returns the value of the specified parameter in the optimization options structure <code>options</code>. You need to type only enough leading characters to define the parameter name uniquely. Case is ignored for parameter names.</p> <p><code>val = optimget(options,'param',default)</code> returns <code>default</code> if the specified parameter is not defined in the optimization options structure <code>options</code>. Note that this form of the function is used primarily by other optimization functions.</p>
<b>Examples</b>	<p>This statement returns the value of the <code>Display</code> optimization options parameter in the structure called <code>my_options</code>.</p> <pre>val = optimget(my_options,'Display')</pre> <p>This statement returns the value of the <code>Display</code> optimization options parameter in the structure called <code>my_options</code> (as in the previous example) except that if the <code>Display</code> parameter is not defined, it returns the value <code>'final'</code>.</p> <pre>optnew = optimget(my_options,'Display','final');</pre>
<b>See Also</b>	<code>optimset</code>   <code>fminbnd</code>   <code>fminsearch</code>   <code>fzero</code>   <code>lsqnonneg</code>

# optimset

---

**Purpose** Create or edit optimization options structure

**Syntax**

```
options = optimset('param1',value1,'param2',value2,...)
optimset
options = optimset
options = optimset(optimfun)
options = optimset(olddopts,'param1',value1,...)
options = optimset(olddopts,newopts)
```

**Description** The function `optimset` creates an options structure that you can pass as an input argument to the following four MATLAB optimization functions:

- `fminbnd`
- `fminsearch`
- `fzero`
- `lsqnonneg`

You can use the `options` structure to change the default parameters for these functions.

---

**Note** If you have an Optimization Toolbox™ license, you can also use `optimset` to create an expanded options structure containing additional options specifically designed for the functions provided in that toolbox. For more information about these additional options, see the reference page for the enhanced Optimization Toolbox `optimset` function.

---

`options = optimset('param1',value1,'param2',value2,...)` creates an optimization options structure called `options`, in which the specified parameters (`param`) have specified values. Any unspecified parameters are set to `[]` (parameters with value `[]` indicate to use the default value for that parameter when `options` is passed to the optimization function). It is sufficient to type only enough leading

characters to define the parameter name uniquely. Case is ignored for parameter names.

`optimset` with no input or output arguments displays a complete list of parameters with their valid values.

`options = optimset` (with no input arguments) creates an options structure `options` where all fields are set to `[]`.

`options = optimset(optimfun)` creates an options structure `options` with all parameter names and default values relevant to the optimization function `optimfun`.

`options = optimset(olddopts,'param1',value1,...)` creates a copy of `olddopts`, modifying the specified parameters with the specified values.

`options = optimset(olddopts,newopts)` combines an existing options structure `olddopts` with a new options structure `newopts`. Any parameters in `newopts` with nonempty values overwrite the corresponding old parameters in `olddopts`.

## Options

The following table lists the available options for the MATLAB optimization functions.

Option	Value	Description	Solvers
Display	'off'   'iter'   {'final'}   'notify'	Level of display. 'off' displays no output; 'iter' displays output at each iteration (not available for <code>lsqnonneg</code> ); 'final' displays just the final output; 'notify' displays output only if	fminbnd, fminsearch,fzero, lsqnonneg

# optimset

Option	Value	Description	Solvers
		the function does not converge.	
FunValCheck	'off'   'on'	Check whether objective function values are valid. 'on' displays an error when the objective function returns a value that is complex or NaN. 'off' displays no error.	fminbnd, fminsearch, fzero
MaxFunEvals	positive integer	Maximum number of function evaluations allowed.	fminbnd, fminsearch
MaxIter	positive integer	Maximum number of iterations allowed.	fminbnd, fminsearch
OutputFcn	function   {}	User-defined function that an optimization function calls at each iteration. See “Output Functions”.	fminbnd, fminsearch, fzero
PlotFcns	function   {}	User-defined or built-in plot function that an optimization function calls at each iteration. Built-in functions: <ul style="list-style-type: none"> <li>• @optimplotx plots the current point</li> <li>• @optimplotfval plots the function value</li> </ul>	fminbnd, fminsearch, fzero

Option	Value	Description	Solvers
		<ul style="list-style-type: none"> <li>@optimplotfunccount plots the function count (not available for fzero)</li> </ul> See “Plot Functions”.	
TolFun	positive scalar	Termination tolerance on the function value. See “Tolerances and Stopping Criteria”.	fminsearch
TolX	positive scalar	Termination tolerance on $x$ , the current point. See “Tolerances and Stopping Criteria”.	fminbnd, fminsearch, fzero, lsqnonneg

## Examples

This statement creates an optimization options structure called `options` in which the `Display` parameter is set to `'iter'` and the `TolFun` parameter is set to `1e-8`.

```
options = optimset('Display','iter','TolFun',1e-8)
```

This statement makes a copy of the options structure called `options`, changing the value of the `TolX` parameter and storing new values in `optnew`.

```
optnew = optimset(options,'TolX',1e-4);
```

This statement returns an optimization options structure that contains all the parameter names and default values relevant to the function `fminbnd`.

```
optimset('fminbnd')
```

## See Also

`optimset` | `optimget` | `fminbnd` | `fminsearch` | `fzero` | `lsqnonneg`

**Purpose** Find logical OR

**Syntax** A | B | ...  
or(A, B)

**Description** A | B | ... performs a logical OR of all input arrays A, B, etc., and returns an array containing elements set to either logical 1 (true) or logical 0 (false). An element of the output array is set to 1 if any input arrays contain a nonzero element at that same array location. Otherwise, that element is set to 0.

Each input of the expression can be an array or can be a scalar value. All nonscalar input arrays must have equal dimensions. If one or more inputs are an array, then the output is an array of the same dimensions. If all inputs are scalar, then the output is scalar.

If the expression contains both scalar and nonscalar inputs, then each scalar input is treated as if it were an array having the same dimensions as the other input arrays. In other words, if input A is a 3-by-5 matrix and input B is the number 1, then B is treated as if it were a 3-by-5 matrix of ones.

or(A, B) is called for the syntax A | B when either A or B is an object.

---

**Note** The symbols | and || perform different operations in a MATLAB application. The element-wise OR operator described here is |. The short-circuit OR operator is ||.

---

## Examples

If matrix A is

0.4235	0.5798	0	0.7942	0
0.5155	0	0	0	0.8744
0	0	0	0.4451	0.0150
0.4329	0.6405	0.6808	0	0

and matrix B is



0	1	0	1	0
1	1	0	0	1
0	0	0	1	0
0	1	0	0	1

then

A		B			
ans	=				
1		1	0	1	0
1		1	0	0	1
0		0	0	1	1
1		1	1	0	1

## See Also

any | all | Logical Operators: Short Circuit | bitor | xor  
| and | not

## Concepts

- “Truth Table for Logical Operations”

# ordeig

---

**Purpose** Eigenvalues of quasitriangular matrices

**Syntax** `E = ordeig(T)`  
`E = ordeig(AA,BB)`

**Description** `E = ordeig(T)` takes a quasitriangular Schur matrix `T`, typically produced by `schur`, and returns the vector `E` of eigenvalues in their order of appearance down the diagonal of `T`.

`E = ordeig(AA,BB)` takes a quasitriangular matrix pair `AA` and `BB`, typically produced by `qz`, and returns the generalized eigenvalues in their order of appearance down the diagonal of `AA -  $\lambda$ *BB`.

`ordeig` is an order-preserving version of `eig` for use with `ordschur` and `ordqz`. It is also faster than `eig` for quasitriangular matrices.

## Examples **Example 1**

```
T=diag([1 -1 3 -5 2]);
```

`ordeig(T)` returns the eigenvalues of `T` in the same order they appear on the diagonal.

```
ordeig(T)
```

```
ans =
```

```
 1
 -1
 3
 -5
 2
```

`eig(T)`, on the other hand, returns the eigenvalues in order of increasing magnitude.

```
eig(T)
```

```
ans =
```

```
-5
-1
 1
 2
 3
```

### Example 2

```
A = rand(10);
[U, T] = schur(A);
abs(ordeig(T))
```

```
ans =
```

```
5.3786
0.7564
0.7564
0.7802
0.7080
0.7080
0.5855
0.5855
0.1445
0.0812
```

```
% Move eigenvalues with magnitude < 0.5 to the
% upper-left corner of T.
```

```
[U,T] = ordschur(U,T,abs(E)<0.5);
abs(ordeig(T))
```

```
ans =
```

```
0.1445
0.0812
5.3786
0.7564
0.7564
0.7802
```

# ordeig

---

0.7080

0.7080

0.5855

0.5855

## **See Also**

schur | qz | ordschur | ordqz | eig

**Purpose** Order fields of structure array

**Syntax**

```
s = orderfields(s1)
s = orderfields(s1, s2)
s = orderfields(s1, c)
s = orderfields(s1, perm)
[s, perm] = orderfields(...)
```

**Description**

`s = orderfields(s1)` orders the fields in `s1` so that the new structure array `s` has field names in ASCII dictionary order.

`s = orderfields(s1, s2)` orders the fields in `s1` so that the new structure array `s` has field names in the same order as those in `s2`. Structures `s1` and `s2` must have the same fields.

`s = orderfields(s1, c)` orders the fields in `s1` so that the new structure array `s` has field names in the same order as those in the cell array of field name strings `c`. Structure `s1` and cell array `c` must contain the same field names.

`s = orderfields(s1, perm)` orders the fields in `s1` so that the new structure array `s` has fieldnames in the order specified by the indices in permutation vector `perm`.

If `s1` has `N` fieldnames, the elements of `perm` must be an arrangement of the numbers from 1 to `N`. This is particularly useful if you have more than one structure array that you would like to reorder in the same way.

`[s, perm] = orderfields(...)` returns a permutation vector representing the change in order performed on the fields of the structure array that results in `s`.

**Tips** `orderfields` only orders top-level fields. It is not recursive.

**Examples** Create a structure `s`. Then create a new structure from `s`, but with the fields ordered alphabetically:

```
s = struct('b', 2, 'c', 3, 'a', 1)
s =
```

# orderfields

---

```
b: 2
c: 3
a: 1
```

```
snew = orderfields(s)
snew =
 a: 1
 b: 2
 c: 3
```

Arrange the fields of `s` in the order specified by the second (cell array) argument of `orderfields`. Return the new structure in `snew` and the permutation vector used to create it in `perm`:

```
[snew, perm] = orderfields(s, {'b', 'a', 'c'})
snew =
 b: 2
 a: 1
 c: 3
perm =
 1
 3
 2
```

Now create a new structure, `s2`, having the same fieldnames as `s`. Reorder the fields using the permutation vector returned in the previous operation:

```
s2 = struct('b', 3, 'c', 7, 'a', 4)
s2 =
 b: 3
 c: 7
 a: 4

snew = orderfields(s2, perm)
snew =
 b: 3
 a: 4
```

c: 7

## See Also

[struct](#) | [isfield](#) | [fieldnames](#) | [setfield](#) | [getfield](#) | [rmfield](#) | [struct2cell](#) | [cell2struct](#)

## Related Examples

- [dynamic field names](#)

# ordqz

**Purpose** Reorder eigenvalues in QZ factorization

**Syntax**  
[AAS,BBS,QS,ZS] = ordqz(AA,BB,Q,Z,select)  
[...] = ordqz(AA,BB,Q,Z,keyword)  
[...] = ordqz(AA,BB,Q,Z,clusters)

**Description** [AAS,BBS,QS,ZS] = ordqz(AA,BB,Q,Z,select) reorders the QZ factorizations  $Q^*A^*Z = AA$  and  $Q^*B^*Z = BB$  produced by the qz function for a matrix pair (A,B). It returns the reordered pair (AAS,BBS) and the cumulative orthogonal transformations QS and ZS such that  $QS^*A^*ZS = AAS$  and  $QS^*B^*ZS = BBS$ . In this reordering, the selected cluster of eigenvalues appears in the leading (upper left) diagonal blocks of the quasitriangular pair (AAS,BBS), and the corresponding invariant subspace is spanned by the leading columns of ZS. The logical vector `select` specifies the selected cluster as  $E(\text{select})$  where E is the vector of eigenvalues as they appear along the diagonal of  $AA^{-1}BB$ .

---

**Note** To extract E from AA and BB, use `ordeig(BB)`, instead of `eig`. This ensures that the eigenvalues in E occur in the same order as they appear on the diagonal of  $AA^{-1}BB$ .

---

[...] = ordqz(AA,BB,Q,Z,keyword) sets the selected cluster to include all eigenvalues in the region specified by keyword:

keyword	Selected Region
'lhp'	Left-half plane ( $\text{real}(E) < 0$ )
'rhp'	Right-half plane ( $\text{real}(E) > 0$ )
'udi'	Interior of unit disk ( $\text{abs}(E) < 1$ )
'udo'	Exterior of unit disk ( $\text{abs}(E) > 1$ )

[...] = ordqz(AA,BB,Q,Z,clusters) reorders multiple clusters at once. Given a vector `clusters` of cluster indices commensurate with  $E = \text{ordeig}(AA,BB)$ , such that all eigenvalues with the same `clusters`



value from one cluster, `ordqz` sorts the specified clusters in descending order along the diagonal of  $(AAS, BBS)$ . The cluster with highest index appears in the upper left corner.

**See Also**

`ordeig` | `ordschur` | `qz`

# ordschur

---

**Purpose** Reorder eigenvalues in Schur factorization

**Syntax**  
[US,TS] = ordschur(U,T,select)  
[US,TS] = ordschur(U,T,keyword)  
[US,TS] = ordschur(U,T,clusters)

**Description** [US,TS] = ordschur(U,T,select) reorders the Schur factorization  $X = U^*T^*U'$  produced by the schur function and returns the reordered Schur matrix TS and the cumulative orthogonal transformation US such that  $X = US^*TS^*US'$ . In this reordering, the selected cluster of eigenvalues appears in the leading (upper left) diagonal blocks of the quasitriangular Schur matrix TS, and the corresponding invariant subspace is spanned by the leading columns of US. The logical vector `select` specifies the selected cluster as  $E(\text{select})$  where  $E$  is the vector of eigenvalues as they appear along  $T$ 's diagonal.

---

**Note** To extract  $E$  from  $T$ , use  $E = \text{ordeig}(T)$ , instead of `eig`. This ensures that the eigenvalues in  $E$  occur in the same order as they appear on the diagonal of  $TS$ .

---

[US,TS] = ordschur(U,T,keyword) sets the selected cluster to include all eigenvalues in one of the following regions:

keyword	Selected Region
'lhp'	Left-half plane ( $\text{real}(E) < 0$ )
'rhp'	Right-half plane ( $\text{real}(E) > 0$ )
'udi'	Interior of unit disk ( $\text{abs}(E) < 1$ )
'udo'	Exterior of unit disk ( $\text{abs}(E) > 1$ )

[US,TS] = ordschur(U,T,clusters) reorders multiple clusters at once. Given a vector `clusters` of cluster indices, commensurate with  $E = \text{ordeig}(T)$ , and such that all eigenvalues with the same `clusters` value form one cluster, `ordschur` sorts the specified clusters

in descending order along the diagonal of  $TS$ , the cluster with highest index appearing in the upper left corner.

**See Also**

ordeig | ordqz | schur

# orient

---

**Purpose** Hardcopy paper orientation

**Alternatives** Use **File** → **Print Preview** on the figure window menu to directly manipulate print layout, paper size, headers, fonts and other properties when printing figures. For details, see Using Print Preview in the MATLAB Graphics documentation.

**Syntax**

```
orient
orient landscape
orient portrait
orient tall
orient(fig_handle)
orient(simulink_model)
orient(fig_handle,orientation)
orient(simulink_model,orientation)
```

**Description** `orient` returns a string with the current paper orientation: `portrait`, `landscape`, or `tall`.

`orient landscape` sets the paper orientation of the current figure to full-page landscape, orienting the longest page dimension horizontally. The figure is centered on the page and scaled to fit the page with a 0.25 inch border.

`orient portrait` sets the paper orientation of the current figure to `portrait`, orienting the longest page dimension vertically. The `portrait` option returns the page orientation to the MATLAB default. (Note that the result of using the `portrait` option is affected by changes you make to figure properties. See the "Algorithm" section for more specific information.)

`orient tall` maps the current figure to the entire page in `portrait` orientation, leaving a 0.25 inch border.

`orient(fig_handle)` returns the current orientation of the specified figure.

`orient(simulink_model)` returns the current orientation of the Simulink model.

`orient(fig_handle,orientation)` sets the orientation for the specified figure to the specified orientation (landscape, portrait, or tall).

`orient(simulink_model,orientation)` sets the orientation for the Simulink model.

## Algorithms

`orient` sets the `PaperOrientation`, `PaperPosition`, and `PaperUnits` properties of the current figure. Subsequent print operations use these properties. The result of using the `portrait` option can be affected by default property values as follows:

- If the current figure `PaperType` is the same as the default figure `PaperType` and the default figure `PaperOrientation` has been set to `landscape`, then the `orient portrait` command uses the current values of `PaperOrientation` and `PaperPosition` to place the figure on the page.
- If the current figure `PaperType` is the same as the default figure `PaperType` and the default figure `PaperOrientation` has been set to `landscape`, then the `orient portrait` command uses the default figure `PaperPosition` with the `x`, `y` and `width`, `height` values reversed (i.e., `[y,x,height,width]`) to position the figure on the page.
- If the current figure `PaperType` is different from the default figure `PaperType`, then the `orient portrait` command uses the current figure `PaperPosition` with the `x`, `y` and `width`, `height` values reversed (i.e., `[y,x,height,width]`) to position the figure on the page.

## See Also

`print` | `printpreview` | `set` | `PaperOrientation` | `PaperPosition` | `PaperSize` | `PaperType` | `PaperUnits`

# orth

---

**Purpose** Orthonormal basis for range of matrix

**Syntax** `Q = orth(A)`

**Description** `Q = orth(A)` returns an orthonormal basis for the range of A. The columns of Q are vectors, which span the range of A. The number of columns in Q is equal to the rank of A.

**Input Arguments**

**A - Input matrix**  
scalar | vector | matrix

Input matrix, specified as a scalar, vector, or matrix.

**Data Types**  
single | double

**Complex Number Support:** Yes

**Examples**

**Basis for Full Rank Matrix**

Calculate and verify the orthonormal basis vectors for the range of a full rank matrix.

Define a matrix and find the rank.

```
A = [1 0 1; -1 -2 0; 0 1 -1];
r = rank(A)
```

```
r =
```

```
3
```

Since A is a square matrix of full rank, the orthonormal basis calculated by `orth(A)` matches the matrix U calculated in the singular value decomposition, `[U,S] = svd(A, 'econ')`. This is because the singular values of A are all nonzero.

Calculate the orthonormal basis for the range of A using `orth`.

```
Q = orth(A)
```

```
Q =
```

```
-0.1200 -0.8097 0.5744
 0.9018 0.1531 0.4042
-0.4153 0.5665 0.7118
```

The number of columns in  $Q$  is equal to  $\text{rank}(A)$ . Since  $A$  is of full rank,  $Q$  and  $A$  are the same size.

Verify that the basis,  $Q$ , is orthogonal and normalized within a reasonable error range.

```
E = norm(eye(r) - Q' * Q, 'fro')
```

```
E =
```

```
9.6228e-16
```

The error is on the order of  $\text{eps}$ .

### **Basis for Rank Deficient Matrix**

Calculate and verify the orthonormal basis vectors for the range of a rank deficient matrix.

Define a singular matrix and find the rank.

```
A = [1 0 1; 0 1 0; 1 0 1];
```

```
r = rank(A)
```

```
r =
```

```
2
```

Since  $A$  is rank deficient, the orthonormal basis calculated by  $\text{orth}(A)$  matches only the first  $r = 2$  columns of matrix  $U$  calculated in the

# orth

---

singular value decomposition,  $[U,S] = \text{svd}(A, 'econ')$ . This is because the singular values of  $A$  are *not* all nonzero.

Calculate the orthonormal basis for the range of  $A$  using `orth`.

$Q = \text{orth}(A)$

$Q =$

```
-0.7071 0
 0 1.0000
-0.7071 0
```

Since  $A$  is rank deficient,  $Q$  contains one fewer column than  $A$ .

## Definitions

### Range

The column space, or *range*, of a matrix  $A$  is the collection of all linear combinations of the columns of  $A$ . Any vector,  $\mathbf{b}$ , that is a solution to the linear equation,  $A\mathbf{x} = \mathbf{b}$ , is included in the range of  $A$  since you can also write it as a linear combination of the columns of  $A$ .

### Rank

The rank of a matrix is equal to the dimension of the range.

## Algorithms

`orth` is obtained from  $U$  in the singular value decomposition,  $[U,S] = \text{svd}(A, 'econ')$ . If  $r = \text{rank}(A)$ , the first  $r$  columns of  $U$  form an orthonormal basis for the range of  $A$ .

## See Also

`null` | `svd` | `rank`



**Purpose** Outer join between two tables

**Syntax**

```
C = outerjoin(A,B)
C = outerjoin(A,B,Name,Value)
[C,ia,ib] = outerjoin(___)
```

**Description** `C = outerjoin(A,B)` creates the table, `C`, as the outer join between the tables `A` and `B` by matching up rows using all the variables with the same name as key variables.

The outer join includes the rows that match between `A` and `B`, and also unmatched rows from either `A` or `B`, all with respect to the key variables. `C` contains all variables from both `A` and `B`, including the key variables.

`C = outerjoin(A,B,Name,Value)` performs the outer-join operation with additional options specified by one or more `Name,Value` pair arguments.

`[C,ia,ib] = outerjoin( ___ )` also returns index vectors, `ia` and `ib`, indicating the correspondence between rows in `C` and those in `A` and `B` respectively. You can use this syntax with any of the input arguments in the previous syntaxes.

## Input Arguments

### **A,B - Input tables**

tables

Input tables, specified as tables.

### **Name-Value Pair Arguments**

Specify optional comma-separated pairs of `Name,Value` arguments. `Name` is the argument name and `Value` is the corresponding value. `Name` must appear inside single quotes ( ' ' ). You can specify several name and value pair arguments in any order as `Name1,Value1,...,NameN,ValueN`.

**Example:** `'Keys',2` uses the second variable in `A` and the second variable in `B` as key variables.

## **'Keys' - Variables to use as keys**

positive integer | vector of positive integers | variable name | cell array of variable names | logical vector

Variables to use as keys, specified as the comma-separated pair consisting of 'Keys' and a positive integer, vector of positive integers, variable name, cell array of variable names, or logical vector.

You cannot use the 'Keys' name-value pair argument with the 'LeftKeys' and 'RightKeys' name-value pair arguments.

**Example:** 'Keys', [1 3] uses the first and third variables in A and B as a key variables.

## **'LeftKeys' - Variables to use as keys in A**

positive integer | vector of positive integers | variable name | cell array of variable names | logical vector

Variables to use as keys in A, specified as the comma-separated pair consisting of 'LeftKeys' and a positive integer, vector of positive integers, variable name, cell array of variable names, or logical vector.

You must use the 'LeftKeys' name-value pair argument in conjunction with the 'RightKeys' name-value pair argument. 'LeftKeys' and 'RightKeys' both must specify the same number of key variables. outerjoin pairs key values based on their order.

**Example:** 'LeftKeys', 1 uses only the first variable in A as a key variable.

## **'RightKeys' - Variables to use as keys in B**

positive integer | vector of positive integers | variable name | cell array of variable names | logical vector

Variables to use as keys in B, specified as the comma-separated pair consisting of 'RightKeys' and a positive integer, vector of positive integers, variable name, cell array of variable names, or logical vector.

You must use the 'RightKeys' name-value pair argument in conjunction with the 'LeftKeys' name-value pair argument.

'LeftKeys' and 'RightKeys' both must specify the same number of key variables. `outerjoin` pairs key values based on their order.

**Example:** 'RightKeys',3 uses only the third variable in B as a key variable.

### 'MergeKeys' - Merge keys flag

false (default) | true | 0 | 1

Merge keys flag, specified as the comma-separated pair consisting of 'MergeKeys' and either false, true, 0 or 1.

**false**                    `outerjoin` includes two separate variables in the output table, C, for each key variable pair from tables A and B.

This is the default behavior.

**true**                    `outerjoin` includes a single variable in the output table, C, for each key variable pair from tables A and B.

`outerjoin` creates the single variable by merging the key values from A and B, taking values from A where a corresponding row exists in A, and taking values from B otherwise.

If you specify, 'MergeKeys',true, then `outerjoin` includes all key variables in the output table, C, and overrides the inclusion or exclusion of key variables specified via the 'LeftVariables' and 'RightVariables' name-value pair arguments.

### 'LeftVariables' - Variables from A to include in C

positive integer | vector of positive integers | variable name | cell array containing one or more variable names | logical vector

Variables from A to include in C, specified as the comma-separated pair consisting of 'LeftVariables' and a positive integer, vector of positive integers, variable name, cell array of variable names, or logical vector.

# outerjoin

---

You can use 'LeftVariables' to include or exclude key variables as well as nonkey variables from the output, C.

By default, outerjoin includes all variables from A.

## 'RightVariables' - Variables from B to include in C

positive integer | vector of positive integers | variable name | cell array containing one or more variable names | logical vector

Variables from B to include in C, specified as the comma-separated pair consisting of 'RightVariables' and a positive integer, vector of positive integers, variable name, cell array of variable names, or logical vector.

You can use 'RightVariables' to include or exclude key variables as well as nonkey variables from the output, C.

By default, outerjoin includes all the variables from B.

## 'Type' - Type of outer join operation

'full' (default) | 'left' | 'right'

Type of outer-join operation, specified as the comma-separated pair consisting of 'Type' and either 'full', 'left', or 'right'.

- For a left outer join, C contains rows corresponding to key values in A that do not match any values in B, but not vice-versa.
- For a right outer join, C contains rows corresponding to key values in B that do not match any values in A, but not vice-versa.

By default, outerjoin does a full outer join and includes unmatched rows from both A and B.

## Output Arguments

### C - Outer join from A and B

table

Outer join from A and B, returned as a table. The output table, C, contains one row for each pair of rows in tables A and B that share the same combination of key values. If A and B contain variables with the same name, outerjoin adds a unique suffix to the corresponding variable names in C. Variables in C that came from A contain null values

in those rows that had no match from B. Similarly, variables in C that came from B contain null values in those rows that had no match from A.

In general, if there are  $m$  rows in table A and  $n$  rows in table B that all contain the same combination of values in the key variables, table C contains  $m*n$  rows for that combination. C also contains rows corresponding to key value combinations in one input table that do not match any row the other input table.

C contains the horizontal concatenation of  $A(ia, LeftVars)$  and  $B(ib, RightVars)$  sorted by the values in the key variables. By default, `LeftVars` consists of all the variables of A, and `RightVars` consists of all the from B. Otherwise, `LeftVars` consists of the variables specified by the 'LeftVariables' name-value pair argument, and `RightVars` consists of the variables specified by the 'RightVariables' name-value pair argument.

You can store additional metadata such as descriptions, variable units, variable names, and row names in the table. For more information, see [Table Properties](#).

### **ia - Index to A**

column vector

Index to A, returned as a column vector. Each element of `ia` identifies the row in table A that corresponds to that row in the output table, C. The vector `ia` contains zeros to indicate the rows in C that do not correspond to rows in A.

### **ib - Index to B**

column vector

Index to B, returned as a column vector. Each element of `ib` identifies the row in table B that corresponds to that row in the output table, C. The vector `ib` contains zeros to indicate the rows in C that do not correspond to rows in B.

## Definitions

### Key Variable

Variable used to match and combine data between the input tables, A and B.

## Examples

### Outer-Join Operation of Tables with One Variable in Common

Create a table, A.

```
A = table([5;12;23;2;15;6],...
 {'cheerios';'pizza';'salmon';'oreos';'lobster';'pizza'},...
 'VariableNames',{'Age','FavoriteFood'},...
 'RowNames',{'Amy','Bobby','Holly','Harry','Marty','Sally'})
```

A =

	Age	FavoriteFood
Amy	5	'cheerios'
Bobby	12	'pizza'
Holly	23	'salmon'
Harry	2	'oreos'
Marty	15	'lobster'
Sally	6	'pizza'

Create a table, B, with one variable in common with A, called FavoriteFood.

```
B = table({'cheerios';'oreos';'pizza';'salmon';'cake'},...
 [110;160;140;367;243],...
 {'A-';'D';'B';'B';'C-'},...
 'VariableNames',{'FavoriteFood','Calories','NutritionGrade'})
```

B =

FavoriteFood	Calories	NutritionGrade
--------------	----------	----------------

'cheerios'	110	'A-'
'oreos'	160	'D'
'pizza'	140	'B'
'salmon'	367	'B'
'cake'	243	'C-'

Use the `outerjoin` function to create a new table, C, with data from tables A and B.

```
C = outerjoin(A,B)
```

```
C =
```

Age	FavoriteFood_A	FavoriteFood_B	Calories	NutritionG
NaN	''	'cake'	243	'C-'
5	'cheerios'	'cheerios'	110	'A-'
15	'lobster'	''	NaN	''
2	'oreos'	'oreos'	160	'D'
12	'pizza'	'pizza'	140	'B'
6	'pizza'	'pizza'	140	'B'
23	'salmon'	'salmon'	367	'B'

Table C contains a separate variable for the key variable from A, called `FavoriteFood_A`, and the key variable from B, called `FavoriteFood_B`.

### Merge Key Variable Pair to Single Variable

Create a table, A.

```
A = table({'a' 'b' 'c' 'e' 'h'},[1 2 3 11 17]',...
 'VariableNames',{'Key1' 'Var1'})
```

```
A =
```

# outerjoin

---

Key1	Var1
'a'	1
'b'	2
'c'	3
'e'	11
'h'	17

Create a table, B, with common values in the variable Key1 between tables A and B, but also containing rows with values of Key1 not present in A.

```
B = table({'a','b','d','e'},[4;5;6;7],...
 'VariableNames',{'Key1' 'Var2'})
```

B =

Key1	Var2
'a'	4
'b'	5
'd'	6
'e'	7

Use the `outerjoin` function to create a new table, C, with data from tables A and B. Merge the key values into a single variable in the output table, C.

```
C = outerjoin(A,B,'MergeKeys',true)
```

C =

Key1	Var1	Var2
'a'	1	4



'b'	2	5
'c'	3	NaN
'd'	NaN	6
'e'	11	7
'h'	17	NaN

Variables in table C that came from A contain null values in the rows that have no match from B. Similarly, variables in C that came from B contain null values in those rows that had no match from A.

### Outer-Join Operation of Tables and Indices to Values

Create a table, A.

```
A = table({'a' 'b' 'c' 'e' 'h'},[1 2 3 11 17]',...
 'VariableNames',{'Key1' 'Var1'})
```

A =

Key1	Var1
'a'	1
'b'	2
'c'	3
'e'	11
'h'	17

Create a table, B, with common values in the variable Key1 between tables A and B, but also containing rows with values of Key1 not present in A.

```
B = table({'a','b','d','e'},[4;5;6;7],...
 'VariableNames',{'Key1' 'Var2'})
```

B =

Key1	Var2
------	------

# outerjoin

---

```
'a' 4
'b' 5
'd' 6
'e' 7
```

Use the `outerjoin` function to create a new table, `C`, with data from tables `A` and `B`. Match up rows with common values in the key variable, `Key1`, but also retain rows whose key values don't have a match.

Also, return index vectors, `ia` and `ib` indicating the correspondence between rows in `C` and rows in `A` and `B` respectively.

```
[C,ia,ib] = outerjoin(A,B)
```

```
C =
```

Key1_A	Var1	Key1_B	Var2
'a'	1	'a'	4
'b'	2	'b'	5
'c'	3	' '	NaN
' '	NaN	'd'	6
'e'	11	'e'	7
'h'	17	' '	NaN

```
ia =
```

```
1
2
3
0
4
5
```

```
ib =
```

```

1
2
0
3
4
0
```

The index vectors `ia` and `ib` contain zeros to indicate the rows in table `C` that do not correspond to rows in tables `A` or `B`, respectively.

### Left Outer-Join Operation of Tables and Indices to Values

Create a table, `A`.

```
A = table({'a' 'b' 'c' 'e' 'h'},[1 2 3 11 17],...
 'VariableNames',{'Key1' 'Var1'})
```

```
A =
```

Key1	Var1
'a'	1
'b'	2
'c'	3
'e'	11
'h'	17

Create a table, `B`, with common values in the variable `Key1` between tables `A` and `B`, but also containing rows with values of `Key1` not present in `A`.

```
B = table({'a','b','d','e'},[4;5;6;7],...
 'VariableNames',{'Key1' 'Var2'})
```

```
B =
```

# outerjoin

---

Key1	Var2
'a'	4
'b'	5
'd'	6
'e'	7

Use the `outerjoin` function to create a new table, `C`, with data from tables `A` and `B`. Ignore rows in `B` whose key values do not match any rows in `A`.

Also, return index vectors, `ia` and `ib` indicating the correspondence between rows in `C` and rows in `A` and `B` respectively.

```
[C,ia,ib] = outerjoin(A,B,'Type','left')
```

`C =`

Key1_A	Var1	Key1_B	Var2
'a'	1	'a'	4
'b'	2	'b'	5
'c'	3	' '	NaN
'e'	11	'e'	7
'h'	17	' '	NaN

`ia =`

```
1
2
3
4
5
```

ib =

1  
2  
0  
4  
0

All values of ia are nonzero indicating that all rows in C have corresponding rows in A.

## See Also

[join](#) | [outerjoin](#)

# pack

---

**Purpose** Consolidate workspace memory

**Syntax**  
`pack`  
`pack filename`  
`pack('filename')`

**Description** `pack` frees up needed space by reorganizing information so that it only uses the minimum memory required. All variables from your base and global workspaces are preserved. Any persistent variables that are defined at the time are set to their default value (the empty matrix, []).

The MATLAB software temporarily stores your workspace data in a file called `tp#####.mat` (where ##### is a numeric value) that is located in your temporary folder. (You can use the command `dir(tempdir)` to see the files in this folder).

`pack filename` frees space in memory, temporarily storing workspace data in a file specified by `filename`. This file resides in your current working folder and, unless specified otherwise, has a `.mat` file extension.

`pack('filename')` is the function form of `pack`.

**Tips** You can only run `pack` from the MATLAB command line.

If you specify a `filename` argument, that file must reside in a folder for which you have write permission.

The `pack` function does not affect the amount of memory allocated to the MATLAB process. You must quit MATLAB to free up this memory.

Since MATLAB uses a heap method of memory management, extended MATLAB sessions may cause memory to become fragmented. When memory is fragmented, there may be plenty of free space, but not enough contiguous memory to store a new large variable.

If you get the `Out of memory` message from MATLAB, the `pack` function may find you some free memory without forcing you to delete variables.

The `pack` function frees space by

- Saving all variables in the base and global workspaces to a temporary file.
- Clearing all variables and functions from memory.
- Reloading the base and global workspace variables back from the temporary file and then deleting the file.

If you use `pack` and there is still not enough free memory to proceed, you must clear some variables. If you run out of memory often, you can allocate larger matrices earlier in the MATLAB session and use these system-specific tips:

- When running MATLAB on The Open Group UNIX platforms, ask your system manager to increase your swap space.
- On Microsoft Windowsplatforms, increase virtual memory using the Windows Control Panel.

To maintain persistent variables when you run `pack`, use `mlock` in the function.

## Examples

Change the current folder to one that is writable, run `pack`, and return to the previous folder.

```
cwd = pwd;
cd(tempdir);
pack
cd(cwd)
```

## See Also

`clear` | `memory`

# padecoeff

---

<b>Purpose</b>	Padé approximation of time delays
<b>Syntax</b>	<code>[num,den] = padecoeff(T,N)</code>
<b>Description</b>	<code>[num,den] = padecoeff(T,N)</code> returns the $N$ th-order Padé approximation of the continuous-time delay $T$ in transfer function form. The row vectors <code>num</code> and <code>den</code> contain the numerator and denominator coefficients in descending powers of $s$ . Both are $N$ th-order polynomials. Class support for input $T$ :  float: double, single
<b>Class Support</b>	Input $T$ support floating-point values of type <code>single</code> or <code>double</code> .
<b>References</b>	[1] Golub, G. H. and C. F. Van Loan <i>Matrix Computations</i> , 3rd ed. Johns Hopkins University Press, Baltimore: 1996, pp. 572–574.
<b>See Also</b>	<code>pade</code>



**Purpose** Page setup dialog box

**Syntax** `dlg = pagesetupdlg(fig)`

---

**Note** `pagesetupdlg` is not recommended. Use `printpreview` instead.

---

**Description** `dlg = pagesetupdlg(fig)` creates a dialog box from which a set of page layout properties for the figure window, `fig`, can be set. `pagesetupdlg` implements the "Page Setup..." option in the **Figure File Menu**.

`pagesetupdlg` supports setting the layout for a single figure. `fig` must be a single figure handle, not a vector of figures or a Simulink diagram.

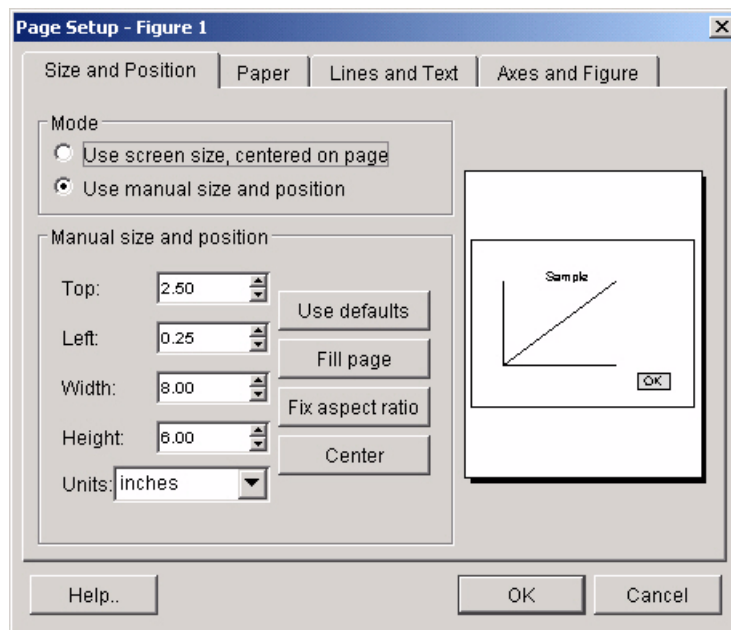

# pagesetupdlg

---

## **See Also**

`printdlg` | `printpreview` | `printopt`

**Purpose** Pan view of graph interactively

**Syntax**

```
pan on
pan xon
pan yon
pan off
pan
pan(figure_handle,...)
h = pan(figure_handle)
```

**Description**

`pan on` turns on mouse-based panning in the current figure.

`pan xon` turns on panning only in the *x* direction in the current figure.

`pan yon` turns on panning only in the *y* direction in the current figure.

`pan off` turns panning off in the current figure.

`pan` toggles the pan state in the current figure on or off.

`pan(figure_handle,...)` sets the pan state in the specified figure.

`h = pan(figure_handle)` returns the figure's pan *mode object* for the figure *figure\_handle* for you to customize the mode's behavior.

### Using Pan Mode Objects

Access the following properties of pan mode objects via `get` and modify some of them using `set`:

- *Enable* 'on' | 'off' — Specifies whether this figure mode is currently enabled on the figure
- *Motion* 'horizontal' | 'vertical' | 'both' — The type of panning enabled for the figure
- `FigureHandle` <handle> — The associated figure handle, a read-only property that cannot be set

### Pan Mode Callbacks

You can program the following callbacks for pan mode operations.

- `ButtonDownFilter` <function\_handle> — Function to intercept `ButtonDown` events

The application can inhibit the panning operation under circumstances the programmer defines, depending on what the callback returns. The input function handle should reference a function with two implicit arguments (similar to Handle Graphics object callbacks):

```
function [res] = myfunction(obj,event_obj)
% obj handle to the object clicked on
% event_obj event data (empty in this release)
% res [output] a logical flag to determine whether the pan
% operation should take place(for 'res' set to 'false')
% or the 'ButtonDownFcn' property of the object should
% take precedence (when 'res' is 'true')
```

- `ActionPreCallback` <function\_handle> — Function to execute before panning

Set this callback to if you need to execute code when a pan operation begins. The function handle should reference a function with two implicit arguments (similar to Handle Graphics object callbacks):

```
function myfunction(obj,event_obj)
% obj handle to the figure that has been clicked on
% event_obj object containing struct of event data
```

The event data struct has the following field:

Axes	The handle of the axes that is being panned
------	---------------------------------------------

- `ActionPostCallback` <function\_handle> — Function to execute after panning

Set this callback if you need to execute code when a pan operation ends. The function handle should reference a function with two implicit arguments (similar to Handle Graphics object callbacks):

```
function myfunction(obj,event_obj)
% obj handle to the figure that has been clicked on
% event_obj object containing struct of event data
% (same as the event data of the
% 'ActionPreCallback' callback)
```

## Pan Mode Utility Functions

The following functions in pan mode query and set certain of its properties.

- `flags = isAllowAxesPan(h,axes)` — Function querying permission to pan axes

Calling the function `isAllowAxesPan` on the pan object, `h`, with a vector of axes handles, `axes`, as input returns a logical array of the same dimension as the axes handle vector, which indicates whether a pan operation is permitted on the axes objects.

- `setAllowAxesPan(h,axes,flag)` — Function to set permission to pan axes

Calling the function `setAllowAxesPan` on the pan object, `h`, with a vector of axes handles, `axes`, and a logical scalar, `flag`, either allows or disallows a pan operation on the axes objects.

- `info = getAxesPanMotion(h,axes)` — Function to get style of pan operations

Calling the function `getAxesPanMotion` on the pan object, `h`, with a vector of axes handles, `axes`, as input will return a character cell array of the same dimension as the axes handle vector, which indicates the type of pan operation for each axes. Possible values for the type of operation are 'horizontal', 'vertical' or 'both'.

- `setAxesPanMotion(h,axes,style)` — Function to set style of pan operations

Calling the function `setAxesPanMotion` on the pan object, `h`, with a vector of axes handles, `axes`, and a character array, `style`, sets the style of panning on each axes.

## Examples

### Example 1 – Entering Pan Mode

Plot a graph and turn on Pan mode:

```
plot(magic(10));
pan on
% pan on the plot
```

### Example 2 – Constrained Pan

Constrain pan to  $x$ -axis using set:

```
plot(magic(10));
h = pan;
set(h,'Motion','horizontal','Enable','on');
% pan on the plot in the horizontal direction.
```

### Example 3 – Constrained Pan in Subplots

Create four axes as subplots and give each one a different panning behavior:

```
ax1 = subplot(2,2,1);
plot(1:10);
h = pan;
ax2 = subplot(2,2,2);
plot(rand(3));
setAllowAxesPan(h,ax2,false);
ax3 = subplot(2,2,3);
plot(peaks);
setAxesPanMotion(h,ax3,'horizontal');
ax4 = subplot(2,2,4);
contour(peaks);
setAxesPanMotion(h,ax4,'vertical');
% pan on the plots.
```

### Example 4 – Coding a ButtonDown Callback

Create a `buttonDown` callback for pan mode objects to trigger. Copy the following code to a new file, execute it, and observe panning behavior:

```
function demo
% Allow a line to have its own 'ButtonDownFcn' callback.
hLine = plot(rand(1,10));
set(hLine,'ButtonDownFcn','disp(''This executes'')');
set(hLine,'Tag','DoNotIgnore');
h = pan;
set(h,'ButtonDownFilter',@mycallback);
set(h,'Enable','on');
% mouse click on the line
%
function [flag] = mycallback(obj,event_obj)
% If the tag of the object is 'DoNotIgnore', then
% return true.

% Indicate what the target is.
disp(['Clicked ' get(obj,'Type') ' object'])
objTag = get(obj,'Tag');
if strcmpi(objTag,'DoNotIgnore')
 flag = true;
else
 flag = false;
end
end
```

### Example 5 – Coding Pre- and Post-Callback Behavior

Create callbacks for pre- and post-`ButtonDown` events for pan mode objects to trigger. Copy the following code to a new file, execute it, and observe panning behavior:

```
function demo
% Listen to pan events
plot(1:10);
h = pan;
set(h,'ActionPreCallback',@myprecallback);
```

```
set(h,'ActionPostCallback',@mypostcallback);
set(h,'Enable','on');
%
function myprecallback(obj, evd)
disp('A pan is about to occur. ');
%
function mypostcallback(obj, evd)
newLim = get(evd.Axes, 'XLim');
msgbox(sprintf('The new X-Limits are [%f,%f].', newLim));
```

## Example 6 – Creating a Context Menu for Pan Mode

Coding a context menu that lets the user to switch to Zoom mode by right-clicking:

```
figure; plot(magic(10));
hCM = uicontextmenu;
hMenu = uimenu('Parent',hCM,'Label','Switch to zoom',...
 'Callback','zoom(gcf,'on')');
hPan = pan(gcf);
set(hPan,'UIContextMenu',hCM);
pan('on')
```

You cannot add items to the built-in pan context menu, but you can replace it with your own.

## Tips

You can create a pan mode object once and use it to customize the behavior of different axes, as Example 3 illustrates. You can also change its callback functions on the fly.



---

**Note Do not change figure callbacks within an interactive mode.** While a mode is active (when panning, zooming, etc.), you will receive a warning if you attempt to change any of the figure’s callbacks and the operation will not succeed. The one exception to this rule is the figure `WindowButtonMotionFcn` callback, which can be changed from within a mode. Therefore, if you are creating a GUI that updates a figure’s callbacks, the GUI should some keep track of which interactive mode is active, if any, before attempting to do this.

---

When you assign different pan behaviors to different subplot axes via a mode object and then link them using the `linkaxes` function, the behavior of the axes you manipulate with the mouse carries over to the linked axes, regardless of the behavior you previously set for the other axes.

## Alternatives

Use the **Pan** tool  on the figure toolbar to enable and disable pan mode on a plot, or select **Pan** from the figure’s **Tools** menu. For details, see “Panning — Shifting Your View of the Graph”.

## See Also

[zoom](#) | [linkaxes](#) | [rotate3d](#)

# matlab.unittest.parameters

---

**Purpose** Summary of classes associated with MATLAB Unit Test parameters

**Description** The matlab.unittest.parameters package consists of the following classes used in parameterized testing.

matlab.unittest.parameters.ClassSetupParameter Specification of Class Setup Parameter

matlab.unittest.parameters.EmptyParameter Empty parameter implementation

matlab.unittest.parameters.MethodSetupParameter Specification of Method Setup Parameter

matlab.unittest.parameters.TestParameter Specification of Test Parameter

**See Also** `matlab.unittest.TestSuite.selectIf`

**Related Examples**

- “Create Basic Parameterized Test”
- “Create Advanced Parameterized Test”

# matlab.unittest.parameters.EmptyParameter

---

<b>Purpose</b>	Empty parameter implementation						
<b>Description</b>	The <code>matlab.unittest.parameters.EmptyParameter</code> class is a <code>Parameter</code> implementation that provides no parameter information. There is no need for test authors to interact with this <code>Parameter</code> directly. This class provides an empty parameter instance to the <code>Parameterization</code> property of a nonparameterized test element.						
<b>Properties</b>	<table><tr><td><b>Property</b></td><td>String indicating the name of the property that defines the Empty Parameter.</td></tr><tr><td><b>Name</b></td><td>String indicating the name that uniquely identifies a particular value for a Empty Parameter.</td></tr><tr><td><b>Value</b></td><td>Value of the Empty Parameter. The <code>Value</code> property holds the data that the Test Runner uses for parameterized testing.</td></tr></table>	<b>Property</b>	String indicating the name of the property that defines the Empty Parameter.	<b>Name</b>	String indicating the name that uniquely identifies a particular value for a Empty Parameter.	<b>Value</b>	Value of the Empty Parameter. The <code>Value</code> property holds the data that the Test Runner uses for parameterized testing.
<b>Property</b>	String indicating the name of the property that defines the Empty Parameter.						
<b>Name</b>	String indicating the name that uniquely identifies a particular value for a Empty Parameter.						
<b>Value</b>	Value of the Empty Parameter. The <code>Value</code> property holds the data that the Test Runner uses for parameterized testing.						
<b>Copy Semantics</b>	Value. To learn how value classes affect copy operations, see <a href="#">Copying Objects in the MATLAB documentation</a> .						
<b>See Also</b>	<code>matlab.unittest.TestCase</code>						
<b>Related Examples</b>	<ul style="list-style-type: none"><li>• “Create Basic Parameterized Test”</li><li>• “Create Advanced Parameterized Test”</li></ul>						
<b>Concepts</b>							

# matlab.unittest.parameters.ClassSetupParameter

---

<b>Purpose</b>	Specification of Class Setup Parameter
<b>Description</b>	The <code>matlab.unittest.parameters.ClassSetupParameter</code> class holds information about a single value of a Class Setup Parameter.
<b>Properties</b>	<b>Property</b> String indicating the name of the property that defines the Class Setup Parameter. <b>Name</b> String indicating the name that uniquely identifies a particular value for a Class Setup Parameter. <b>Value</b> Value of the Class Setup Parameter. The <code>Value</code> property holds the data that the Test Runner uses for parameterized testing.
<b>Copy Semantics</b>	Value. To learn how value classes affect copy operations, see <a href="#">Copying Objects</a> in the MATLAB documentation.
<b>See Also</b>	<code>matlab.unittest.TestCase</code>
<b>Related Examples</b>	<ul style="list-style-type: none"><li>• “Create Basic Parameterized Test”</li><li>• “Create Advanced Parameterized Test”</li></ul>
<b>Concepts</b>	

# matlab.unittest.parameters.TestParameter

---

<b>Purpose</b>	Specification of Test Parameter						
<b>Description</b>	The <code>matlab.unittest.parameters.TestParameter</code> class holds information about a single value of a Test Parameter.						
<b>Properties</b>	<table><tr><td><b>Property</b></td><td>String indicating the name of the property that defines the Test Parameter.</td></tr><tr><td><b>Name</b></td><td>String indicating the name that uniquely identifies a particular value for a Test Parameter.</td></tr><tr><td><b>Value</b></td><td>Value of the Test Parameter. The <code>Value</code> property holds the data that the Test Runner uses for parameterized testing.</td></tr></table>	<b>Property</b>	String indicating the name of the property that defines the Test Parameter.	<b>Name</b>	String indicating the name that uniquely identifies a particular value for a Test Parameter.	<b>Value</b>	Value of the Test Parameter. The <code>Value</code> property holds the data that the Test Runner uses for parameterized testing.
<b>Property</b>	String indicating the name of the property that defines the Test Parameter.						
<b>Name</b>	String indicating the name that uniquely identifies a particular value for a Test Parameter.						
<b>Value</b>	Value of the Test Parameter. The <code>Value</code> property holds the data that the Test Runner uses for parameterized testing.						
<b>Copy Semantics</b>	Value. To learn how value classes affect copy operations, see <a href="#">Copying Objects in the MATLAB documentation</a> .						
<b>See Also</b>	<code>matlab.unittest.TestCase</code>						
<b>Related Examples</b>	<ul style="list-style-type: none"><li>• “Create Basic Parameterized Test”</li><li>• “Create Advanced Parameterized Test”</li></ul>						
<b>Concepts</b>							

# matlab.unittest.parameters.MethodSetupParameter

---

<b>Purpose</b>	Specification of Method Setup Parameter
<b>Description</b>	The <code>matlab.unittest.parameters.MethodSetupParameter</code> class holds information about a single value of a Method Setup Parameter.
<b>Properties</b>	<p><b>Property</b></p> <p>String indicating the name of the property that defines the Method Setup Parameter.</p> <p><b>Name</b></p> <p>String indicating the name that uniquely identifies a particular value for a Method Setup Parameter.</p> <p><b>Value</b></p> <p>Value of the Method Setup Parameter. The <code>Value</code> property holds the data that the Test Runner uses for parameterized testing.</p>
<b>Copy Semantics</b>	Value. To learn how value classes affect copy operations, see <a href="#">Copying Objects</a> in the MATLAB documentation.
<b>See Also</b>	<code>matlab.unittest.TestCase</code>
<b>Related Examples</b>	<ul style="list-style-type: none"><li>• “Create Basic Parameterized Test”</li><li>• “Create Advanced Parameterized Test”</li></ul>
<b>Concepts</b>	

**Purpose**

Pareto chart

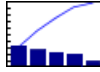
**Syntax**

```
pareto(Y)
pareto(Y, names)
pareto(Y, X)
H = pareto(...)
```

**Description**

Pareto charts display the values in the vector  $Y$  as bars drawn in descending order. Values in  $Y$  must be nonnegative and not include NaNs. Only the first 95% of the cumulative distribution is displayed.

`pareto(Y)` labels each bar with its element index in  $Y$  and also plots a line displaying the cumulative sum of  $Y$ .

`pareto(Y, names)` labels each bar with the associated name in the string matrix or cell array `names`.

`pareto(Y, X)` labels each bar with the associated value from  $X$ .

`pareto(ax, ...)` plots a Pareto chart in existing axes `ax` rather than GCA.

`H = pareto(...)` returns a combination of patch and line object handles.

**Examples****Create Pareto Chart**

Create a Pareto chart of vector `y`.

```
y = [90,75,30,60,5,40,40,5];
figure
pareto(y)
```

## pareto

---

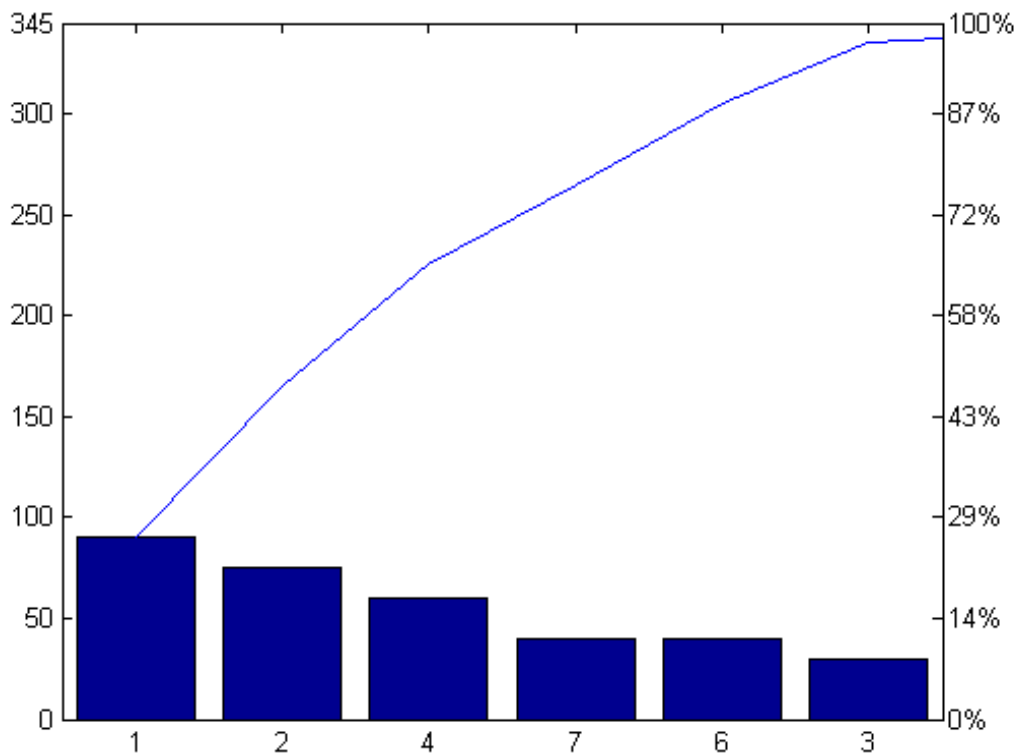

`pareto` displays the elements in `y` as bars in descending order and labels each bar with its index in `y`. Since `pareto` displays only the first 95% of the cumulative distribution, some elements in `y` are not displayed.

### Label Bars in Pareto Chart

Examine the cumulative productivity of a group of programmers to see how normal its distribution is. Label each bar with the name of the programmer.



```
codelines = [200 120 555 608 1024 101 57 687];
coders = {'Fred', 'Ginger', 'Norman', 'Max', 'Julia', 'Wally', 'Heidi', 'Pat'}

figure
pareto(codelines, coders)
title('Lines of Code by Programmer')
```

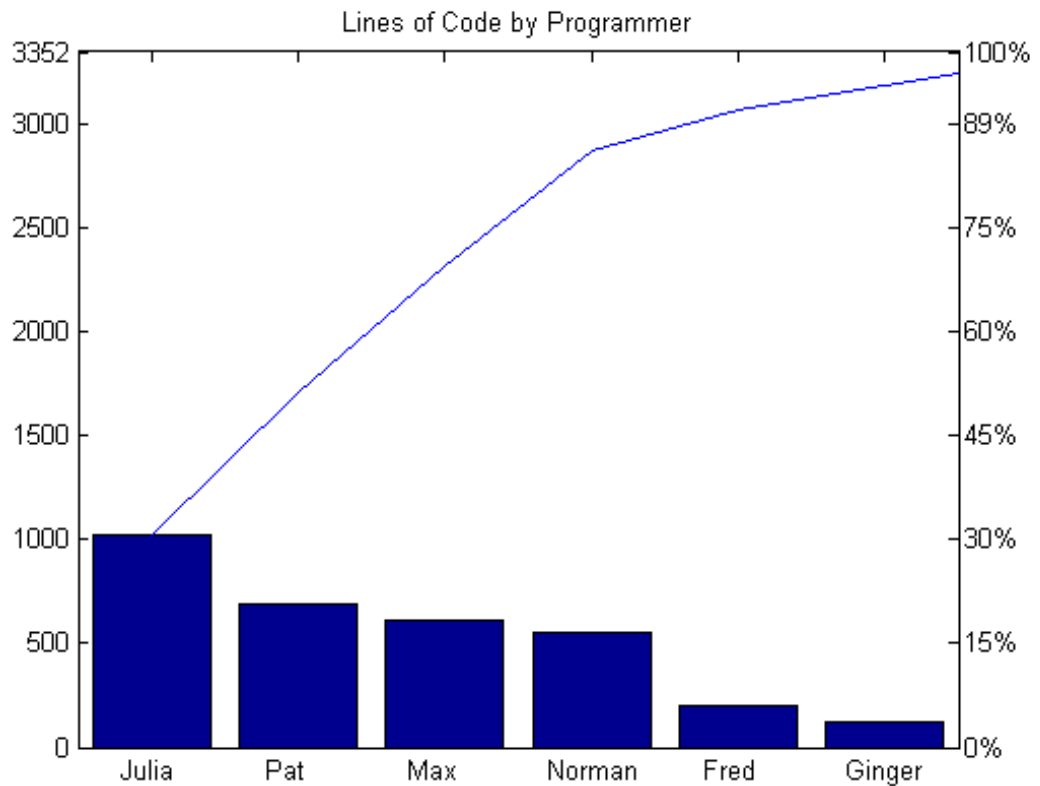
**Tips**

You can use `pareto` to display the output of `hist`, even for vectors that include negative numbers. Because only the first 95 percent of values

## pareto

---

are displayed, one or more of the smallest bars may not appear. If you extend the `Xlim` of your chart, you can display all the values, but the new bars will not be labeled.

You cannot place datatips (use the Datacursor tool) on graphs created with `pareto`.

### See Also

`hist` | `bar`

---

<b>Purpose</b>	Parallel for loop
<b>Syntax</b>	<pre>parfor loopvar = initval:endval; <i>statements</i>; end parfor (loopvar = initval:endval, M); <i>statements</i>; end</pre>
<b>Description</b>	<p>parfor loopvar = initval:endval; <i>statements</i>; end executes a series of MATLAB statements for values of loopvar between initval and endval, inclusive, which specify a vector of increasing integer values. The loop runs in parallel when you have the Parallel Computing Toolbox™ or when you create a MEX function with MATLAB Coder™. Unlike a traditional for-loop, iterations are not executed in a guaranteed order.</p> <p>parfor (loopvar = initval:endval, M); <i>statements</i>; end executes statements in a loop using a maximum of M workers or threads, where M is a nonnegative integer.</p>
<b>Tips</b>	<ul style="list-style-type: none"><li>• If you have Parallel Computing Toolbox software, see the function reference pages for parfor and parpool for additional information.</li><li>• If you have MATLAB Coder software, see the parfor function reference page for additional information.</li></ul>
<b>Examples</b>	<p>Perform three large eigenvalue computations using three workers or cores with Parallel Computing Toolbox software:</p> <pre>parpool(3) parfor i=1:3, c(:,i) = eig(rand(1000)); end</pre>
<b>See Also</b>	for

# inputParser.parse

---

<b>Purpose</b>	Parse function inputs
<b>Syntax</b>	parse(p, argList)
<b>Description</b>	parse(p, argList) parses and validates the inputs in arglist.
<b>Input Arguments</b>	<b>p</b> Object of class inputParser. <b>argList</b> Comma separated list of inputs to parse and validate for your custom function. The class of each input depends upon your function definition.

## Examples **Input Parsing**

Parse and validate required and optional function inputs.

Create a custom function with required and optional inputs in the file findArea.m.

```
function a = findArea(width,varargin)
 p = inputParser;
 defaultHeight = 1;
 defaultUnits = 'inches';
 defaultShape = 'rectangle';
 expectedShapes = {'square','rectangle','parallelogram'};

 addRequired(p,'width',@isnumeric);
 addOptional(p,'height',defaultHeight,@isnumeric);
 addParameter(p,'units',defaultUnits);
 addParameter(p,'shape',defaultShape,...
 @(x) any(validatestring(x,expectedShapes)));

 parse(p,width,varargin{:});
 a = p.Results.width .* p.Results.height;
```

The input parser checks whether `width` and `height` are numeric, and whether the `shape` matches a string in cell array `expectedShapes`. `@` indicates a function handle, and the syntax `@(x)` creates an anonymous function with input `x`.

Call the function with inputs that do not match the scheme. For example, specify a nonnumeric value for the `width` input:

```
findArea('text')
```

```
Error using findArea (line 14)
The value of 'width' is invalid. It must satisfy the function: isnumeric.
```

Specify an unsupported value for `shape`:

```
findArea(4, 'shape', 'circle')
```

```
Error using findArea (line 14)
The value of 'shape' is invalid. Expected input to match one of these strings:

square, rectangle, parallelogram

The input, 'circle', did not match any of the valid strings.
```

## See Also

[addOptional](#) | [addParameter](#) | [addRequired](#) | [inputParser](#)

# parseSoapResponse

---

**Purpose** Convert response string from SOAP server into MATLAB types

**Syntax** parseSoapResponse(response)

**Description** parseSoapResponse(response) extracts data from response a string returned by a SOAP server from the callSoapService function, and converts it to appropriate MATLAB classes (types).

**Examples** This example uses parseSoapResponse in conjunction with other SOAP functions to retrieve information about books from a library database, specifically, the author's name for a given book title.

---

**Note** The example does not use an actual endpoint; therefore, you cannot run it. The example only illustrates how to use the SOAP functions.

---

```
% Create the message:
message = createSoapMessage(...
'urn:LibraryCatalog',...
'getAuthor',...
{'In the Fall'},...
{'nameToLookUp'},...
{'{http://www.w3.org/2001/XMLSchema}string'},...
'rpc');
%
% Send the message to the service and get the response:
response = callSoapService(...
'http://test/soap/services/LibraryCatalog',...
'urn:LibraryCatalog#getAuthor',...
message)
%
% Extract MATLAB data from the response
author = parseSoapResponse(response)
```

MATLAB returns:

```
author = Kate Alvin
```

where author is a char class (type).

## See Also

[callSoapService](#) | [createClassFromWsd1](#) | [createSoapMessage](#) | [urlread](#) | [xmlread](#)

## How To

- “Access Web Services Using MATLAB SOAP Functions”

# pascal

---

**Purpose** Pascal matrix

**Syntax**  
A = pascal(n)  
A = pascal(n,1)  
A = pascal(n,2)

**Description** A = pascal(n) returns the Pascal matrix of order n: a symmetric positive definite matrix with integer entries taken from Pascal's triangle. The inverse of A has integer entries.

A = pascal(n,1) returns the lower triangular Cholesky factor (up to the signs of the columns) of the Pascal matrix. It is *involutary*, that is, it is its own inverse.

A = pascal(n,2) returns a transposed and permuted version of pascal(n,1). A is a cube root of the identity matrix.

**Examples** pascal(4) returns

```
1 1 1 1
1 2 3 4
1 3 6 10
1 4 10 20
```

A = pascal(3,2) produces

```
A =
 1 1 1
 -2 -1 0
 1 0 0
```

**See Also** chol



**Purpose**

Create one or more filled polygons

**Syntax**

```
patch(X,Y,C)
patch(X,Y,Z,C)
patch(FV)
patch(X,Y,C, 'PropertyName',propertyvalue...)
patch('PropertyName',propertyvalue,...)
handle = patch(...)
```

**Properties**

For a list of properties, see [Patch Properties](#).

**Description**

`patch(X,Y,C)` adds a filled 2-D patch object to the current axes. A patch object is one or more polygons defined by the coordinates of its vertices. The elements of `X` and `Y` specify the vertices of a polygon. If `X` and `Y` are `m`-by-`n` matrices, MATLAB draws `n` polygons with `m` vertices. `C` determines the color of the patch. For more information on color input requirements, see “Coloring Patches” on page 1-4899.

MATLAB does not require each face to have the same number of vertices. In cases where they do not, pad the end of the `Faces` matrix with NaNs. To define a patch with faces that do not close, add one or more NaNs to the row in the `Vertices` matrix that defines the vertex you do not want connected.

See “Introduction to Patch Objects” for more information on using patch objects.

`patch(X,Y,Z,C)` creates a patch in 3-D coordinates. If the coordinate data does not define closed polygons, `patch` closes the polygons. The data can define concave or intersecting polygons. However, if the edges of an individual patch face intersect themselves, the resulting face might be only partly filled. In that case, it is better to divide the face into smaller polygons.

`patch(FV)` creates a patch using structure `FV`, which contains the fields `vertices`, `faces`, and optionally `facevertexcdata`. These fields correspond to the `Vertices`, `Faces`, and `FaceVertexCData` patch properties. Specifying only unique vertices and their connection matrix

can reduce the size of the data for patches having many faces. For an example of how to specify patches with this method, see “Specifying Patch Object Shapes” on page 1-4896.

`patch(X,Y,C,'PropertyName',propertyvalue...)` follows the `X`, `Y`, (`Z`), and `C` arguments with property name/property value pairs to specify additional patch properties. For a description of the properties, see [Patch Properties](#). You can specify properties as property name/property value pairs, structure arrays, and cell arrays (see the [set](#) and [get](#) reference pages for examples of how to specify these data types).

`patch('PropertyName',propertyvalue,...)` specifies all properties using property name/property value pairs. This form lets you omit the color specification because MATLAB uses the default face color and edge color unless you explicitly assign a value to the `FaceColor` and `EdgeColor` properties. This form also lets you specify the patch using the `Faces` and `Vertices` properties instead of `x`-, `y`-, and `z`-coordinates. See “Specifying Patch Object Shapes” on page 1-4896 for more information.

`handle = patch(...)` returns the handle of the patch object it creates.

Unlike high-level area creation functions, such as `fill` or `area`, `patch` does not check the settings of the figure and axes `NextPlot` properties. It simply adds the patch object to the current axes.

## Examples

### Specifying Patch Object Shapes

The next two examples create a patch object using two methods:

- Specifying `x`-, `y`-, and `z`-coordinates and color data (`XData`, `YData`, `ZData`, and `CData` properties)
- Specifying vertices, the connection matrix, and color data (`Vertices`, `Faces`, and `FaceVertexCData` properties)

Create five triangular faces, each having three vertices, by specifying the `x`-, `y`-, and `z`-coordinates of each vertex:

```
xdata = [2 2 0 2 5;
 2 8 2 4 5;
```

```

 8 8 2 4 8];
ydata = [4 4 4 2 0;
 8 4 6 2 2;
 4 0 4 0 0];
zdata = ones(3,5);

% Red numbers denote the vertex indices.
% For this example:
% xindices = [1 4 7 10 13;
% 2 5 8 11 14;
% 3 6 9 12 15];
% Blue numbers denote the face numbers.
patch(xdata,ydata,zdata,'w')

```

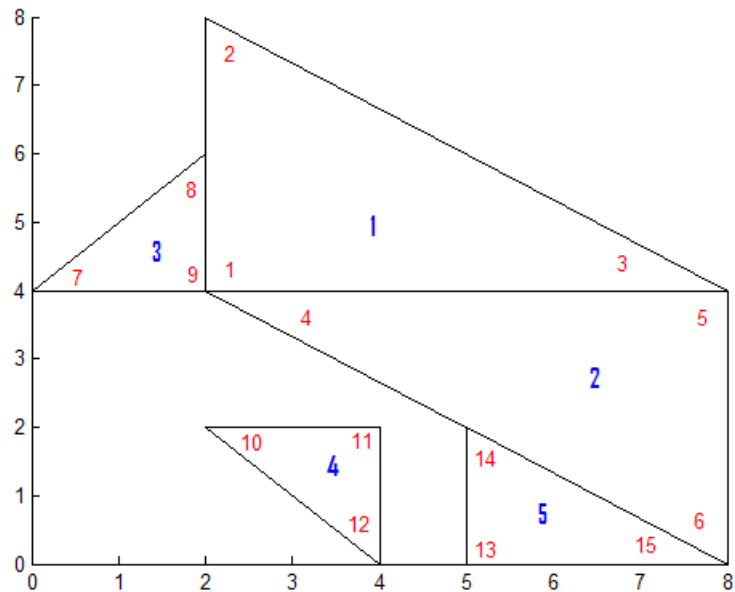

Create the five triangular faces, specifying faces and vertices:

% The Vertices property contains the coordinates of each

# patch

---

```
% unique vertex defining the patch. The Faces property
% specifies how to connect these vertices to form each
% face of the patch. More than one face may
% use a given vertex.
% For this example, five triangles have 11 total vertices,
% instead of 15. Each row contains
% the x- and y-coordinates
% of each vertex.
verts = [2 4; ...
 2 8; ...
 8 4; ...
 8 0; ...
 0 4; ...
 2 6; ...
 2 2; ...
 4 2; ...
 4 0; ...
 5 2; ...
 5 0];

% There are five faces, defined by connecting the
% vertices in the order indicated.
faces = [...
 1 2 3; ...
 1 3 4; ...
 5 6 1; ...
 7 8 9; ...
 11 10 4];

% Create the patch by specifying the Faces, Vertices,
% and FaceVertexCData properties as well as the
% FaceColor property. Red numbers denote the vertex
% numbers, as defined in faces. Blue indicate face numbers.
p = patch('Faces',faces,'Vertices',verts,'FaceColor','w');
```

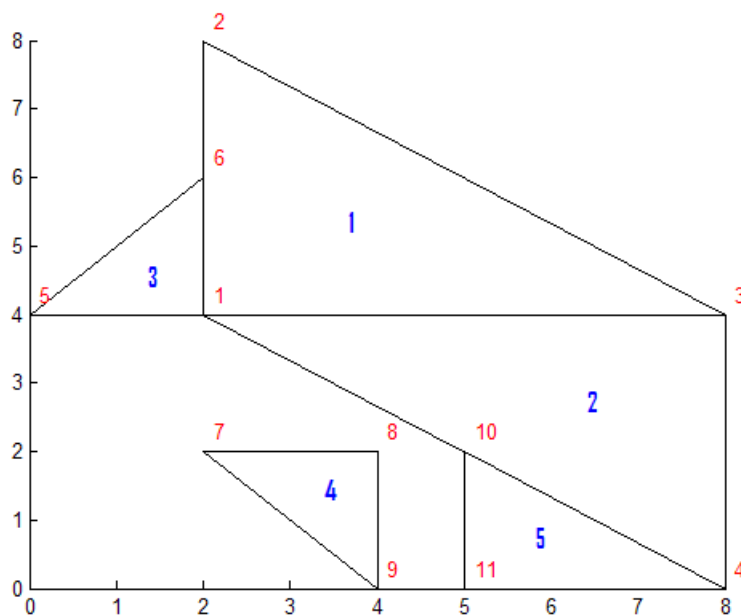

```
% Using the previous values for verts and faces, you can
% create the same patch object using a structure:
patchinfo.Vertices = verts;
patchinfo.Faces = faces;
patchinfo.FaceColor = 'w';
```

```
patch(patchinfo);
```

### Coloring Patches

There are many ways to customize your patch objects using colors. The appropriate input depends on:

- Whether you want to change the edge colors
- How you specified the patch faces:
  - Using face/vertex values
  - Using  $x$ -,  $y$ -, and  $z$ -coordinates

The following sections present the various options available.

## Specifying Edge Colors

The following options apply to the edge colors of your patch object. The settings are independent of the face colors, but the colors themselves depend on the colors specified at each vertex. Markers show the color at each vertex. Specify the colors using the `EdgeColor` property. To explore the options using the Sample Input Code, create a base patch object:

```
xdata = [2 2 0 2 5;
 2 8 2 4 5;
 8 8 2 4 8];
ydata = [4 4 4 2 0;
 8 4 6 2 2;
 4 0 4 0 0];
cdata = [15 0 4 6 10;
 1 2 5 7 9;
 2 3 0 8 3];
p = patch(xdata,ydata,cdata,'Marker','o',...
 'MarkerFaceColor','flat',...
 'FaceColor','none')
```

For more detailed information on how the `EdgeColor` property works, see the [Patch Properties](#) page.

Desired Look	EdgeColor Value	Sample Code
All edges have the same color, around all faces. This option does not rely on the <code>FaceColor</code> value.	<code>ColorSpec</code>	<code>set(p, 'EdgeColor', 'g')</code>

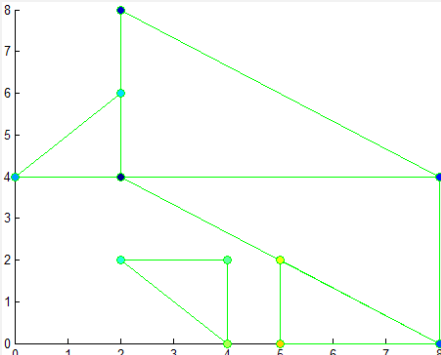
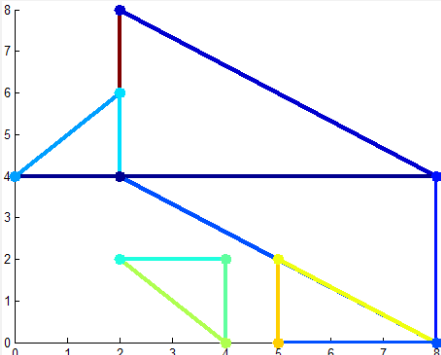
Desired Look	EdgeColor Value	Sample Code
		
<p>Each edge corresponds to the color of the vertex that precedes the edge, with one color per edge. This option requires that the FaceColor property be flat or interp. By default, if you specify CData when creating the patch object, its FaceColor property is interp.</p> 	<p>'flat'</p>	<pre>set(p, 'EdgeColor', 'flat', ...     'LineWidth', 3)</pre>

# patch

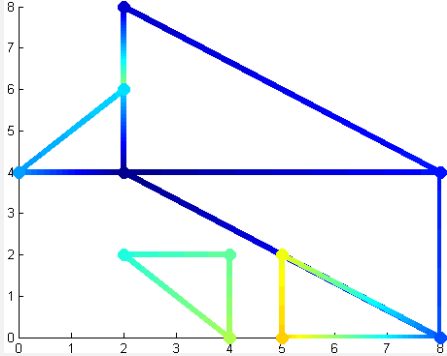
Desired Look	EdgeColor Value	Sample Code
<p>Each edge corresponds to the vertex colors, interpolated between vertices. This option requires that the FaceColor property be flat or interp. By default, if you specify CData when creating the patch object, its FaceColor property is interp.</p> 	'interp'	<pre>set(gcf, 'Renderer', 'zbuffer') set(p, 'EdgeColor', 'interp', ... 'LineWidth', 5)</pre>
<p>Edges have no color. This option does not rely on the FaceColor value. If set, markers retain vertex colors.</p>	'none'	<pre>set(p, 'EdgeColor', 'none')</pre>

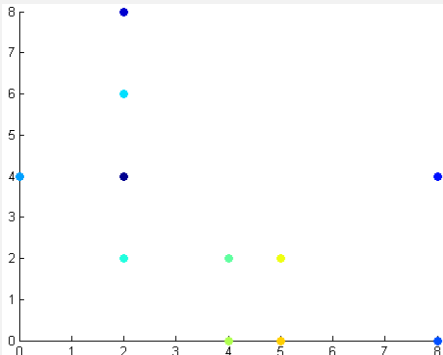

Desired Look	EdgeColor Value	Sample Code
		

### Specifying Face Colors Using Face/Vertex Input Matrices

The following options apply to the face colors of your patch object when you specify the faces using face/vertex input matrices. To explore the options, start with a base patch object:

```
% For this example, there are five triangles (m = 5)
% sharing eleven unique vertices (k = 11).
verts = [2 4; ...
 2 8; ...
 8 4; ...
 8 0; ...
 0 4; ...
 2 6; ...
 2 2; ...
 4 2; ...
 4 0; ...
 5 2; ...
 5 0];
faces = [1 2 3; ...
 1 3 4; ...
 5 6 1; ...
 7 8 9; ...
 11 10 4];
```

# patch

```
p = patch('Faces',faces,'Vertices',verts,'FaceColor','b');
```

For more information on the relevant properties, see [FaceColor](#), [FaceVertexCData](#), and [CDataMapping](#).

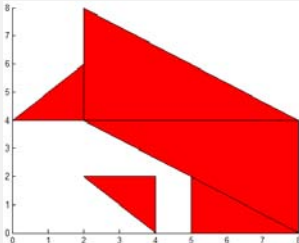
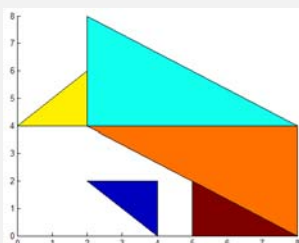
Desired Look	Parameter Values	Sample Code
<p>All faces have the same color.</p> 	<ul style="list-style-type: none"> <li>• <b>FaceColor:</b> ColorSpec</li> <li>• <b>FaceVertexCData:</b> [] (no input) An empty array is the default value, and patch ignores any input until you set FaceColor to 'flat' or 'interp'.</li> <li>• <b>Color source:</b> truecolor</li> <li>• <b>CDataMapping:</b> 'direct' or 'scaled'. 'scaled' is the default value, but neither affects the outcome.</li> </ul>	<pre>set(p,'FaceColor','r')  or  set(p,'FaceColor',[1 0 0])</pre>
<p>Each face has a single, unique color, indexed from a selected section of the colormap.</p> 	<ul style="list-style-type: none"> <li>• <b>FaceColor:</b> 'flat'</li> <li>• <b>FaceVertexCData:</b> m-by-1 matrix of index values</li> <li>• <b>Color source:</b> A selected portion of the colormap</li> <li>• <b>CDataMapping:</b> 'scaled'</li> </ul>	<pre>clear cdata set(gca,'CLim',[0 40]) cdata = [15 30 25 2 60]'; set(p,'FaceColor','flat',...     'FaceVertexCData',cdata,...     'CDataMapping','scaled')</pre>

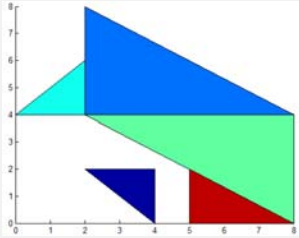
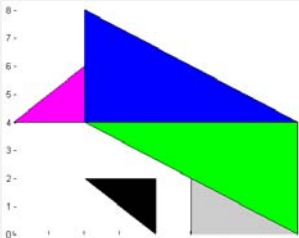
Desired Look	Parameter Values	Sample Code
<p>Each face has a single, unique color, indexed from the whole colormap.</p> 	<ul style="list-style-type: none"> <li>• FaceColor: 'flat'</li> <li>• FaceVertexCData: m-by-1 matrix of index values</li> <li>• Color source: colormap</li> <li>• CDataMapping: 'direct'</li> </ul> <p>'scaled' is the default value when you input CData values. If you want to change the axes CLim property, but want your patch object to index the entire colormap, use 'CDataMapping', 'direct'.</p>	<pre>clear cdata set(gca,'CLim',[0 40]) cdata = [15 30 25 2 60]'; set(p,'FaceColor','flat',... 'FaceVertexCData',cdata,... 'CDataMapping','direct')</pre>
<p>Each face has a single, unique color, determined by truecolor value input.</p> 	<ul style="list-style-type: none"> <li>• FaceColor: 'flat'</li> <li>• FaceVertexCData: m-by-3 matrix of truecolor values, from 0 to 1</li> <li>• Color source: truecolor</li> <li>• CDataMapping: 'direct' or 'scaled'.</li> </ul> <p>'scaled' is the default value, but neither affects the outcome.</p>	<pre>clear cdata cdata = [0 0 1 0 0.8;          0 1 0 0 0.8;          1 0 1 0 0.8]'; set(p,'FaceColor','flat',... 'FaceVertexCData',cdata)</pre>

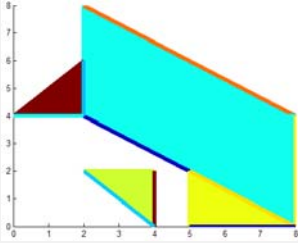
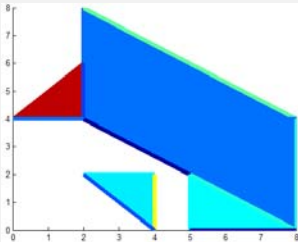
Desired Look	Parameter Values	Sample Code
<p>Each unique vertex has a single, unique color, indexed from a selected section of the colormap. Faces each have a single, unique color, but edges may have 'flat' or 'interp' color.</p> 	<ul style="list-style-type: none"> <li>• FaceColor: 'flat'</li> <li>• FaceVertexCData: k-by-1 matrix of index values</li> <li>• Color source: A selected portion of the colormap</li> <li>• CDataMapping: 'scaled'</li> </ul>	<pre>clear cdata set(gca,'CLim',[0 40]) cdata = [15 30 25 2 ... 60 12 23 40 13 26 24]'; set(p,'FaceColor','flat',... 'FaceVertexCData',cdata,... 'EdgeColor','flat',... 'LineWidth',5,... 'CDataMapping','scaled')</pre>
<p>Each unique vertex has a single, unique color, indexed from the whole colormap. Faces each have a single, unique color, but edges may have 'flat' or 'interp' color.</p> 	<ul style="list-style-type: none"> <li>• FaceColor: 'flat'</li> <li>• FaceVertexCData: k-by-1 matrix of index values</li> <li>• Color source: colormap</li> <li>• CDataMapping: 'direct'</li> </ul> <p>'scaled' is the default value when you input CData values. If you want to change the axes CLim property, but want your patch object to index the entire colormap, use 'CDataMapping','direct'.</p>	<pre>clear cdata set(gca,'CLim',[0 40]) cdata = [15 30 25 2 ... 60 12 23 40 13 26 24]'; set(p,'FaceColor','flat',... 'FaceVertexCData',cdata,... 'CDataMapping','direct',... 'EdgeColor','flat',... 'LineWidth',5)</pre>

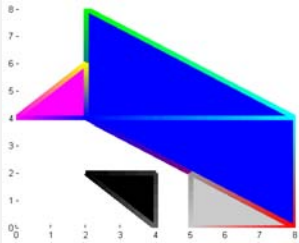
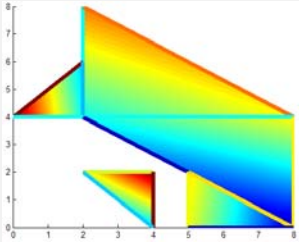
Desired Look	Parameter Values	Sample Code
<p>Each unique vertex has a single, unique color, determined by truecolor value input. Faces each have a single, unique color, but edges may have 'flat' or 'interp' color.</p> 	<ul style="list-style-type: none"> <li>• FaceColor: 'flat'</li> <li>• FaceVertexCData: k-by-3 matrix of truecolor values, from 0 to 1</li> <li>• Color source: truecolor</li> <li>• CDataMapping: 'direct' or 'scaled'.</li> </ul> <p>'scaled' is the default value, but neither affects the outcome.</p>	<pre>clear cdata cdata = [0 0 1;          0 1 0;          0 1 1;          1 0 0;          1 0 1;          1 1 0;          1 1 0;          0 0 0;          0.2 0.2 0.2;          0.4 0.4 0.4;          0.6 0.6 0.6;          0.8 0.8 0.8]; set(p,'FaceColor','flat',...     'FaceVertexCData',cdata,...     'EdgeColor','interp',...     'LineWidth',5)</pre>
<p>Each unique vertex has a single, unique color, indexed from a selected section of the colormap. Edges may have 'flat' or 'interp' color.</p> 	<ul style="list-style-type: none"> <li>• FaceColor: 'interp'</li> <li>• FaceVertexCData: k-by-1 matrix of index values</li> <li>• Color source: A selected portion of the colormap</li> <li>• CDataMapping: 'scaled'</li> </ul>	<pre>clear cdata set(gca,'CLim',[0 40]) cdata = [15 30 25 2 ...         60 12 23 40 13 26 24]'; set(p,'FaceColor','interp',...     'FaceVertexCData',cdata,...     'EdgeColor','flat',...     'LineWidth',5,...     'CDataMapping','scaled')</pre>

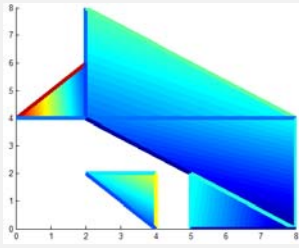
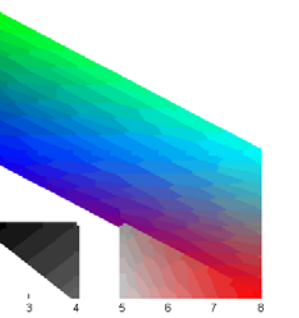
Desired Look	Parameter Values	Sample Code
<p>Each unique vertex has a single, unique color, indexed from the whole colormap. Edges may have 'flat' or 'interp' color.</p> 	<ul style="list-style-type: none"> <li>• FaceColor: 'interp'</li> <li>• FaceVertexCData: k-by-1 matrix of index values</li> <li>• Color source: colormap</li> <li>• CDataMapping: 'direct'</li> </ul> <p>'scaled' is the default value when you input CData values. If you want to change the axes CLim property, but want your patch object to index the entire colormap, use 'CDataMapping', 'direct'.</p>	<pre>clear cdata set(gca,'CLim',[0 40]) cdata = [15 30 25 2 ...         60 12 23 40 13 26 24]; set(p,'FaceColor','interp',...     'FaceVertexCData',cdata,...     'CDataMapping','direct',...     'EdgeColor','flat',...     'LineWidth',5)</pre>
<p>Each unique vertex has a single, unique color, determined by truecolor value input. Edges may have 'flat' or 'interp' color.</p> 	<ul style="list-style-type: none"> <li>• FaceColor: 'interp'</li> <li>• FaceVertexCData: k-by-3 matrix of truecolor values, from 0 to 1</li> <li>• Color source: truecolor</li> <li>• CDataMapping: 'direct' or 'scaled'.</li> </ul> <p>'scaled' is the default value, but neither affects the outcome.</p>	<pre>clear cdata cdata = [0 0 1;         0 1 0;         0 1 1;         1 0 0;         1 0 1;         1 1 0;         0 0 0;         0.2 0.2 0.2;         0.4 0.4 0.4;         0.6 0.6 0.6;         0.8 0.8 0.8]; set(p,'FaceColor','interp',...     'FaceVertexCData',cdata,...     'EdgeColor','interp',...     'LineWidth',5)</pre>

### Specifying Face Colors Using x-, y-, and z-Coordinate Input

The following options apply to the face colors of your patch object when you specify the faces using x-, y-, and z-coordinates. To explore the options, start with a base patch object:

```
% For this example, there are five (m=5) triangles (n=3).
% The total number of vertices is mxn, or k = 15.
xdata = [2 2 0 2 5;
 2 8 2 4 5;
 8 8 2 4 8];
ydata = [4 4 4 2 0;
 8 4 6 2 2;
 4 0 4 0 0];
zdata = ones(3,5);
p = patch(xdata,ydata,zdata,'b')
```

For more information on the relevant properties, see [FaceColor](#), [CData](#), and [CDataMapping](#).

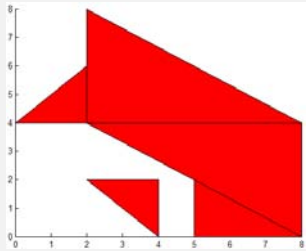
Desired Look	Parameter Values	Sample Code
<p>All faces have the same color.</p> 	<ul style="list-style-type: none"> <li>• FaceColor: ColorSpec</li> <li>• CData: [] (no input)</li> <li>• Color source: truecolor</li> <li>• CDataMapping: 'direct' or 'scaled'.  'scaled' is the default value, but neither affects the outcome.</li> </ul>	<pre>set(p,'FaceColor','r')  or  set(p,'FaceColor',[1 0 0])</pre>
<p>Each face has a single, unique color, indexed from a selected section of the colormap.</p>	<ul style="list-style-type: none"> <li>• FaceColor: 'flat'</li> <li>• CData: m-by-1 matrix of index values</li> </ul>	<pre>clear cdata set(gca,'CLim',[0 40]) cdata = [15 30 25 2 60];</pre>

# patch

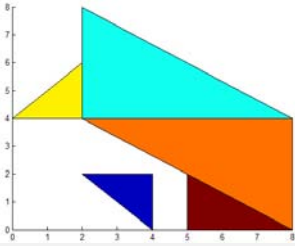
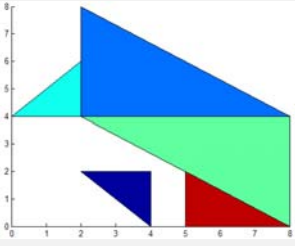
Desired Look	Parameter Values	Sample Code
	<ul style="list-style-type: none"> <li>• Color source: A selected portion of the colormap</li> <li>• CDataMapping: 'scaled'</li> </ul>	<pre>set(p, 'FaceColor', 'flat', ...       'CData', cdata, ...       'CDataMapping', 'scaled')</pre>
<p>Each face has a single, unique color, indexed from the whole colormap.</p> 	<ul style="list-style-type: none"> <li>• FaceColor: 'flat'</li> <li>• CData: m-by-1 matrix of index values</li> <li>• Color source: colormap</li> <li>• CDataMapping: 'direct'</li> </ul> <p>'scaled' is the default value when you input CData values. If you want to change the axes CLim property, but want your patch object to index the entire colormap, use 'CDataMapping', 'direct'.</p>	<pre>clear cdata set(gca, 'CLim', [0 40]) cdata = [15 30 25 2 60]; set(p, 'FaceColor', 'flat', ...       'CData', cdata, ...       'CDataMapping', 'direct')</pre>

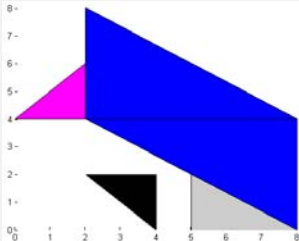
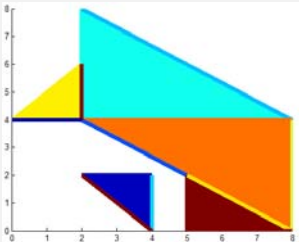

Desired Look	Parameter Values	Sample Code
<p>Each face has a single, unique color, determined by truecolor value input.</p> 	<ul style="list-style-type: none"> <li>• FaceColor: 'flat'</li> <li>• CData: m-by-1-by-3 matrix of truecolor values, from 0 to 1</li> <li>• Color source: truecolor</li> <li>• CDataMapping: 'direct' or 'scaled'.  'scaled' is the default value, but neither affects the outcome.</li> </ul>	<pre>clear cdata cdata(:,:,1) = [0 0 1 0 0.8]; cdata(:,:,2) = [0 0 0 0 0.8]; cdata(:,:,3) = [1 1 1 0 0.8]; set(p,'FaceColor','flat',... 'CDATA',cdata)</pre>
<p>Each unique vertex has a single, unique color, indexed from a selected section of the colormap. Faces each have a single, unique color, but edges may have 'flat' or 'interp' color.</p> 	<ul style="list-style-type: none"> <li>• FaceColor: 'flat'</li> <li>• CData: m-by-n matrix of index values</li> <li>• Color source: A selected portion of the colormap</li> <li>• CDataMapping: 'scaled'</li> </ul>	<pre>clear cdata set(gca,'CLim',[0 40]) cdata = [15 30 25 2 60;         12 23 40 13 26;         24 8 1 65 42]; set(p,'FaceColor','flat',... 'CDATA',cdata,... 'EdgeColor','flat',... 'LineWidth',5,... 'CDatamapping','scaled')</pre>

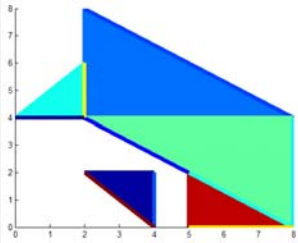
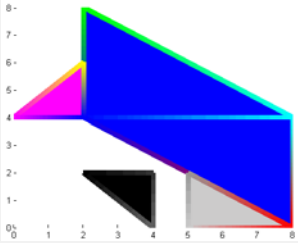
Desired Look	Parameter Values	Sample Code
<p>Each unique vertex has a single, unique color, indexed from the whole colormap. Faces each have a single, unique color, but edges may have 'flat' or 'interp' color.</p> 	<ul style="list-style-type: none"> <li>• FaceColor: 'flat'</li> <li>• CData: m-by-n matrix of index values</li> <li>• Color source: colormap</li> <li>• CDataMapping: 'direct'</li> </ul> <p>'scaled' is the default value when you input CData values. If you want to change the axes CLim property, but want your patch object to index the entire colormap, use 'CDataMapping', 'direct'.</p>	<pre>clear cdata set(gca,'CLim',[0 40]) cdata = [15 30 25 2 60;         12 23 40 13 26;         24 8 1 65 42]; set(p,'FaceColor','flat',...     'CData',cdata,...     'CDataMapping','direct',...     'EdgeColor','flat',...     'LineWidth',5)</pre>
<p>Each vertex has a single, unique color, determined by truecolor value input. Faces each have a single, unique color, but edges may have 'flat' or 'interp' color.</p> 	<ul style="list-style-type: none"> <li>• FaceColor: 'flat'</li> <li>• CData: m-by-n-by-3 matrix of truecolor values, from 0 to 1</li> <li>• Color source: truecolor</li> <li>• CDataMapping: 'direct' or 'scaled'.</li> </ul> <p>'scaled' is the default value, but neither affects the outcome.</p>	<pre>clear cdata cdata(:,:,1) = [0 0 1 0 0.8;                 0 0 1 0.2 0.6;                 0 1 0 0.4 1]; cdata(:,:,2) = [0 0 0 0 0.8;                 1 1 1 0.2 0.6;                 1 0 0 0.4 0]; cdata(:,:,3) = [1 1 1 0 0.8;                 0 1 0 0.2 0.6;                 1 0 1 0.4 0]; set(p,'FaceColor','flat',...     'CData',cdata,...     'EdgeColor','interp',...     'LineWidth',5)</pre>

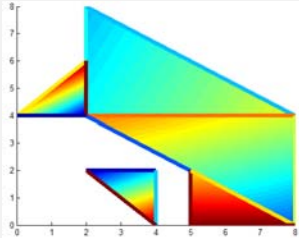
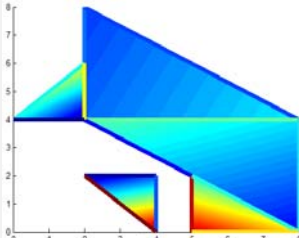
Desired Look	Parameter Values	Sample Code
<p>Each vertex has a single, unique color, indexed from a selected section of the colormap. Edges may have 'flat' or 'interp' color.</p> 	<ul style="list-style-type: none"> <li>• FaceColor: 'interp'</li> <li>• CData: m-by-n matrix of index values</li> <li>• Color source: A selected portion of the colormap</li> <li>• CDataMapping: 'scaled'</li> </ul>	<pre>clear cdata set(gca,'CLim',[0 40]) cdata = [15 30 25 2 60;          12 23 40 13 26;          24 8 1 65 42]; set(p,'FaceColor','interp',...      'CData',cdata,...      'EdgeColor','flat',...      'LineWidth',5,...      'CDataMapping','scaled')</pre>
<p>Each vertex has a single, unique color, indexed from the whole colormap. Edges may have 'flat' or 'interp' color.</p> 	<ul style="list-style-type: none"> <li>• FaceColor: 'interp'</li> <li>• CData: m-by-n matrix of index values</li> <li>• Color source: colormap</li> <li>• CDataMapping: 'direct'</li> </ul> <p>'scaled' is the default value when you input CData values. If you want to change the axes CLim property, but want your patch object to index the entire colormap, use 'CDataMapping','direct'.</p>	<pre>clear cdata set(gca,'CLim',[0 40]) cdata = [15 30 25 2 60;          12 23 40 13 26;          24 8 1 65 42]; set(p,'FaceColor','interp',...      'CData',cdata,...      'CDataMapping','direct',...      'EdgeColor','flat',...      'LineWidth',5)</pre>
<p>Each vertex has a single, unique color, determined by truecolor value input. Edges</p>	<ul style="list-style-type: none"> <li>• FaceColor: 'interp'</li> <li>• CData: m-by-n-by-3 matrix of truecolor values, from 0 to 1</li> </ul>	<pre>clear cdata cdata(:,:,1) = [0.8 0.1 0.2                 0.9 0.3 1;                 ...                 ...                 ...]</pre>

# patch

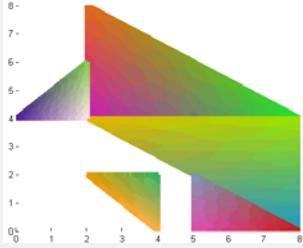
Desired Look	Parameter Values	Sample Code
<p>may have 'flat' or 'interp' color.</p> 	<ul style="list-style-type: none"><li>• Color source: truecolor</li><li>• CDataMapping: 'direct' or 'scaled'.</li></ul> <p>'scaled' is the default value, but neither affects the outcome.</p>	<pre>0.1 0.5 0.9; 0.9 1 0.5; 0.6 0.9 0.8];  cdata(:, : , 2) =[0.1 0.6 0.7; 0.4 0.1 0.7; 0.9 0.8 0.3; 0.7 0.9 0.6; 0.9 0.6 0.1];  cdata(:, : , 3) =[0.7 0.8 0.4; 0.1 0.6 0.3; 0.2 0.3 0.7; 0.0 0.9 0.7; 0.0 0.0 0.1];  set(p, 'FaceColor', 'interp', ... 'CDATA', cdata, ... 'EdgeColor', 'interp', ... 'LineWidth', 5)</pre>

## See Also

[area](#) | [caxis](#) | [fill](#) | [fill3](#) | [isosurface](#) | [surface](#) | [FaceColor](#) | [CData](#) | [CDataMapping](#) | [FaceVertexCData](#) | [Patch Properties](#)

## Tutorials

- “Introduction to Patch Objects”

## Purpose

Patch properties

## Creating Patch Objects

Use patch to create patch objects.

## Modifying Properties

You can set and query graphics object properties in two ways:

- “Customize Objects in Graph” is an interactive tool that enables you to see and change object property values.
- The set and get commands enable you to set and query the values of properties.

To change the default values of properties, see “Setting Default Property Values”.

See “Core Graphics Objects” for general information about this type of object.

## Patch Property Descriptions

This section provides a description of properties. Curly braces { } enclose default values.

AlphaDataMapping  
none | {scaled} | direct

*Transparency mapping method.* Determines how the MATLAB software interprets indexed alpha data.

- none — The transparency values of FaceVertexAlphaData are between 0 and 1 or are clamped to this range.
- scaled — Transform the FaceVertexAlphaData to span the portion of the alphamap indicated by the axes ALim property, linearly mapping data values to alpha values.
- direct — Use the FaceVertexAlphaData as indices directly into the alphamap. When not scaled, the data are usually integer values ranging from 1 to length(alphamap). MATLAB maps values less than 1 to the first alpha value in the

# Patch Properties

---

alphamap, and values greater than `length(alphamap)` to the last alpha value in the alphamap. Values with a decimal portion are fixed to the nearest lower integer. If `FaceVertexAlphaData` is an array of `uint8` integers, then the indexing begins at 0 (that is, MATLAB maps a value of 0 to the first alpha value in the alphamap).

## AmbientStrength

scalar  $\geq 0$  and  $\leq 1$

*Strength of ambient light.* Sets the strength of the ambient light, which is a nondirectional light source that illuminates the entire scene. You must have at least one visible light object in the axes for the ambient light to be visible. The axes `AmbientLightColor` property sets the color of the ambient light, which is therefore the same on all objects in the axes.

You can also set the strength of the diffuse and specular contribution of light objects. See the patch `DiffuseStrength` and `SpecularStrength` properties.

## Annotation

hg.Annotation object (read-only)

*Handle of Annotation object.* The Annotation property enables you to specify whether this patch object is represented in a figure legend.

Querying the Annotation property returns the handle of an `hg.Annotation` object. The `hg.Annotation` object has a property called `LegendInformation`, which contains an `hg.LegendEntry` object.

Once you have obtained the `hg.LegendEntry` object, you can set its `IconDisplayStyle` property to control whether the patch object is displayed in a figure legend:

IconDisplayStyle Value	Purpose
on	Represent this patch object in a legend (default)
off	Do not include this patch object in a legend
children	Same as on because patch objects do not have children

## Setting the IconDisplayStyle property

Set the IconDisplayStyle of a graphics object with handle `hobj` to off:

```
hAnnotation = get(hobj, 'Annotation');
hLegendEntry = get(hAnnotation, 'LegendInformation');
set(hLegendEntry, 'IconDisplayStyle', 'off')
```

## Using the IconDisplayStyle property

See “Control Legend Content” for more information and examples.

## Selecting which objects to display in legend

Some graphics functions create multiple objects. For example, `contour3` uses patch objects to create a 3D contour graph. You can use the Annotation property set select a subset of the objects for display in the legend.

```
[X,Y] = meshgrid(-2:.1:2);
[Cm hC] = contour3(X.*exp(-X.^2-Y.^2));
hA = get(hC, 'Annotation');
hLL = get([hA{:}], 'LegendInformation');
% Set the IconDisplayStyle property to display
% the first, fifth, and ninth patch in the legend

set([hLL{:}], {'IconDisplayStyle'}, ...
```

# Patch Properties

---

```
 {'on','off','off','off','on','off','off','off','on'})
% Assign DisplayNames for the three patch
% that are displayed in the legend

set(hC([1,5,9]),{'DisplayName'},...
 {'bottom','middle','top'})
legend show
```

**BackFaceLighting**  
unlit | lit | {reverselit}

*Face lighting control.* Determines how faces are lit when their vertex normals point away from the camera.

- **unlit** — Face not lit.
- **lit** — Face lit in normal way.
- **reverselit** — Face lit as if the vertex pointed towards the camera.

Use this property to discriminate between the internal and external surfaces of an object. See “Back Face Lighting” for an example.

**BeingDeleted**  
on | {off} (read-only)

*This object is being deleted.* Mechanism to determine if objects are in the process of being deleted. MATLAB sets the **BeingDeleted** property to on when the object’s delete function callback is called (see the **DeleteFcn** property). It remains set to on while the delete function executes, after which the object no longer exists.

For example, an object’s delete function calls other functions that act on a number of different objects. If a function does not need to perform an action on an about-be-deleted object, it can check the object’s **BeingDeleted** property before acting.



**BusyAction**  
cancel | {queue}

### *Callback queuing*

Determines how MATLAB handles the execution of interrupting callbacks.

A *running* callback is the currently executing callback. The *interrupting* callback is the callback that tries to interrupt the *running* callback. The **BusyAction** property of the *interrupting* callback determines how MATLAB handles its execution. When the **BusyAction** property is set to:

- 'queue' — Puts the *interrupting* callback in a queue to be processed after the *running* callback finishes execution.
- 'cancel' — Discards the *interrupting* callback as MATLAB finishes execution.

For information about how the **Interruptible** property of the callback controls whether other callbacks can interrupt the *running* callback, see the **Interruptible** property description.

**ButtonDownFcn**  
function handle | cell array containing function handle and additional arguments | string (not recommended)

*Button press callback function.* Executes whenever you press a mouse button while the pointer is over the patch object.

See the figure's **SelectionType** property to determine if modifier keys were also pressed.

Set this property to a function handle that references the callback. You can also use a string that is a valid MATLAB expression or the name of a MATLAB file. The expressions execute in the MATLAB workspace.

# Patch Properties

For information on the syntax of callback functions, see [Function Handle Callbacks](#).

## CData

scalar | vector | matrix

*Patch colors.* Specifies the color of the patch. You can specify color for each vertex, each face, or a single color for the entire patch. The way MATLAB interprets CData depends on the type of data supplied. The data can be numeric values that are scaled to map linearly into the current colormap, integer values that are used directly as indices into the current colormap, or arrays of RGB values. RGB values are not mapped into the current colormap, but interpreted as the colors defined. On true color systems, MATLAB uses the actual colors defined by the RGB triples.

The following diagrams illustrate the dimensions of CData with respect to the coordinate data arrays, XData, YData, and ZData. The first diagram illustrates the use of indexed color.

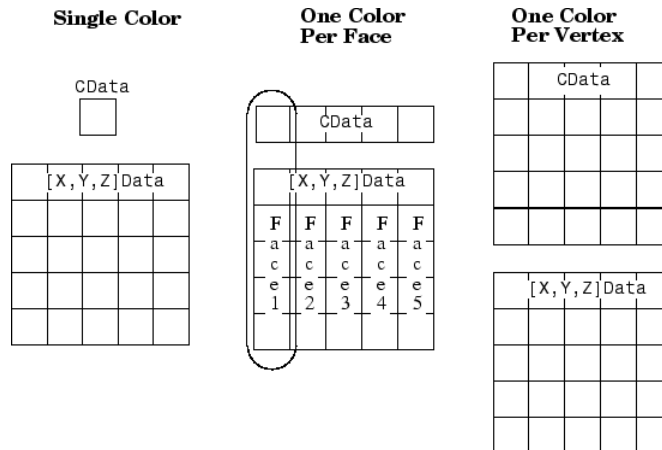

The following diagram illustrates the use of true color. True color requires m-by-n-by-3 arrays to define red, green, and blue components for each color.

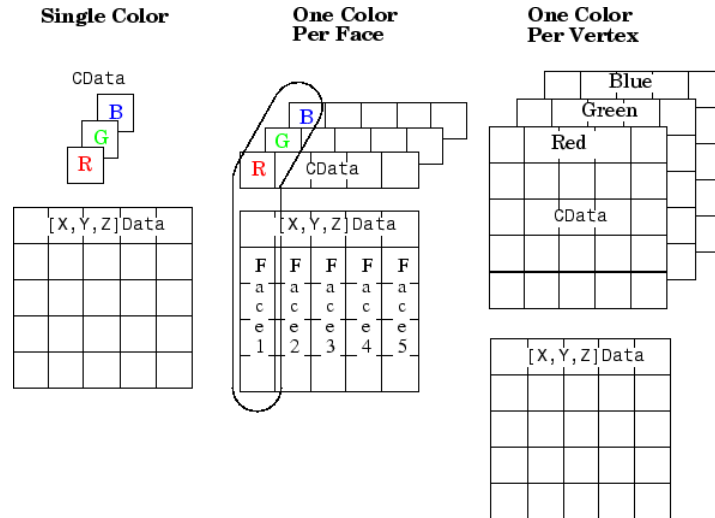

Note that if CData contains NaNs, MATLAB does not color the faces.

See the Faces, Vertices, and FaceVertexCData properties for an alternative method of patch definition.

CDataMapping  
 {scaled} | direct

*Direct or scaled color mapping.* Determines how MATLAB interprets indexed color data used to color the patch. If you use true color specification for CData or FaceVertexCData, this property has no effect.

- **scaled** — Transform the color data to span the portion of the colormap indicated by the axes CLim property, linearly

# Patch Properties

---

mapping data values to colors. See the `caxis` command for more information on this mapping.

- `direct` — Use the color data as indices directly into the colormap. When not scaled, the data are usually integer values ranging from 1 to `length(colormap)`. MATLAB maps values less than 1 to the first color in the colormap, and values greater than `length(colormap)` to the last color in the colormap. Values with a decimal portion are fixed to the nearest lower integer.

## Children

matrix of handles

Always the empty matrix; patch objects have no children.

## Clipping

`{on}` | `off`

*Clipping to axes rectangle.* When `Clipping` is on, MATLAB does not display any portion of the patch outside the axes rectangle.

## CreateFcn

string | function handle

*Callback routine executed during object creation.* Executes when MATLAB creates a patch object. You must define this property as a default value for patches or in a call to the `patch` function that creates a new object.

For example, the following statement creates a patch (assuming `x`, `y`, `z`, and `c` are defined), and executes the function referenced by the function handle `@myCreateFcn`.

```
patch(x,y,z,c,'CreateFcn',@myCreateFcn)
```

MATLAB executes the create function after setting all properties for the patch created. Setting this property on an existing patch object has no effect.

The handle of the object whose `CreateFcn` is being executed is accessible only through the root `CallbackObject` property, which you can query using `gcbo`.

For information on the syntax of callback functions, see [Function Handle Callbacks](#).

## DeleteFcn

string | function handle

*Delete patch callback routine.* Executes when you delete the patch object (for example, when you issue a `delete` command or clear the axes (`cla`) or figure (`clf`) containing the patch). MATLAB executes the routine before deleting the object's properties so these values are available to the callback routine.

The handle of the object whose `DeleteFcn` is being executed is accessible only through the root `CallbackObject` property, which you can query using `gcbo`.

For information on the syntax of callback functions, see [Function Handle Callbacks](#).

## DiffuseStrength

scalar  $\geq 0$  and  $\leq 1$

*Intensity of diffuse light.* Sets the intensity of the diffuse component of the light falling on the patch. Diffuse light comes from light objects in the axes.

You can also set the intensity of the ambient and specular components of the light on the object. See the `AmbientStrength` and `SpecularStrength` properties.

## DisplayName

string

# Patch Properties

---

*String used by legend.* The `legend` function uses the `DisplayName` property to label the patch object in the legend. The default is an empty string.

- If you specify string arguments with the `legend` function, MATLAB set `DisplayName` to the corresponding string and uses that string for the legend.
- If `DisplayName` is empty, `legend` creates a string of the form, `['data' n]`, where  $n$  is the number assigned to the object based on its location in the list of legend entries. However, `legend` does not set `DisplayName` to this string.
- If you edit the string directly in an existing legend, MATLAB set `DisplayName` to the edited string.
- If you specify a string for the `DisplayName` property and create the legend using the figure toolbar, then MATLAB uses the string defined by `DisplayName`.
- To add a legend programmatically that uses the `DisplayName` string, call `legend` with the `toggle` or `show` option.

See “Control Legend Content” for more information and examples.

## EdgeAlpha

{scalar = 1} | flat | interp

*Transparency of the edges of patch faces.*

- `scalar` — A single non-`NaN` scalar value between 0 and 1 that controls the transparency of all the edges of the object. 1 (the default) means fully opaque and 0 means completely transparent.
- `flat` — The alpha data (`FaceVertexAlphaData`) of each vertex controls the transparency of the edge that follows it.
- `interp` — Linear interpolation of the alpha data (`FaceVertexAlphaData`) at each vertex determines the transparency of the edge.

Note that you cannot specify `flat` or `interp` `EdgeAlpha` without first setting `FaceVertexAlphaData` to a matrix containing one alpha value per face (`flat`) or one alpha value per vertex (`interp`).

## EdgeColor

`{ColorSpec} | none | flat | interp`

*Color of the patch edge.* Determines how MATLAB colors the edges of the individual faces that make up the patch.

- `ColorSpec` — A three-element RGB vector or one of the MATLAB predefined names, specifying a single color for edges. The default value is `[0 0 0]` (black). See the `ColorSpec` reference page for more information on specifying color.
- `none` — Edges not drawn.
- `flat` — The color of each vertex controls the color of the edge that follows it. This means `flat` edge coloring is dependent on the order in which you specify the vertices:

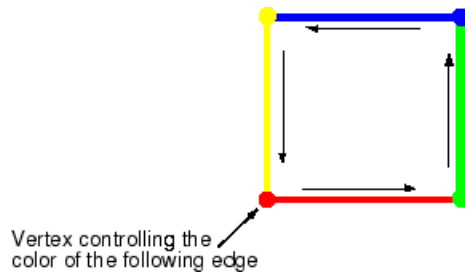

- `interp` — Linear interpolation of the `CData` or `FaceVertexCData` values at the vertices determines the edge color.

## EdgeLighting

`{none} | flat | gouraud | phong`

*Algorithm used for lighting calculations.* Selects the algorithm used to calculate the effect of light objects on patch edges.

- `none` — Lights do not affect the edges of this object.

# Patch Properties

---

- `flat` — The effect of light objects is uniform across each edge of the patch.
- `gouraud` — The effect of light objects is calculated at the vertices and then linearly interpolated across the edge lines.
- `phong` — The effect of light objects is determined by interpolating the vertex normals across each edge line and calculating the reflectance at each pixel. Phong lighting generally produces better results than Gouraud lighting, but takes longer to render.

## EraseMode

`{normal} | none | xor | background`

*Erase mode.* Controls the technique MATLAB uses to draw and erase patch objects. Alternative erase modes are useful in creating animated sequences, where control of the way individual objects redraw is necessary to improve performance and obtain the desired effect.

- `normal` — Redraw the affected region of the display, performing the three-dimensional analysis necessary to ensure that all objects are rendered correctly. This mode produces the most accurate picture, but is the slowest. The other modes are faster, but do not perform a complete redraw and are therefore less accurate.
- `none` — Do not erase the patch when it is moved or destroyed. While the object is still visible on the screen after erasing with `EraseMode none`, you cannot print it because MATLAB stores no information about its former location.
- `xor` — Draw and erase the patch by performing an exclusive OR (XOR) with each pixel index of the screen behind it. Erasing the patch does not damage the color of the objects behind it. However, patch color depends on the color of the screen behind it and is correctly colored only when over the axes background `Color`, or the figure background `Color` if the axes `Color` is `none`.



- **background** — Erase the patch by drawing it in the axes background `Color`, or the figure background `Color` if the axes `Color` is none. This damages objects that are behind the erased patch, but the patch is always properly colored.

## Printing with Nonnormal Erase Modes

MATLAB always prints figures as if the `EraseMode` of all objects is `normal`. This means graphics objects created with `EraseMode` set to `none`, `xor`, or `background` can look different on screen than on paper. On screen, MATLAB mathematically combines layers of colors (for example, performing an XOR on a pixel color with that of the pixel behind it) and ignore three-dimensional sorting to obtain greater rendering speed. However, these techniques are not applied to the printed output.

You can use the `getframe` command or other screen capture applications to create an image of a figure containing nonnormal mode objects.

### FaceAlpha

{scalar = 1} | flat | interp

*Transparency of the patch face.*

- **scalar** — A single non-`NaN` value between 0 and 1 that controls the transparency of all the faces of the object. 1 (the default) means fully opaque and 0 means completely transparent (invisible).
- **flat** — The values of the alpha data (`FaceVertexAlphaData`) determine the transparency for each face. The alpha data at the first vertex determines the transparency of the entire face.
- **interp** — Bilinear interpolation of the alpha data (`FaceVertexAlphaData`) at each vertex determines the transparency of each face.

# Patch Properties

---

Note that you cannot specify `flat` or `interp` `FaceAlpha` without first setting `FaceVertexAlphaData` to a matrix containing one alpha value per face (`flat`) or one alpha value per vertex (`interp`).

## FaceColor

`{ColorSpec} | none | flat | interp`

*Color of the patch face.*

- `ColorSpec` — A three-element RGB vector or one of the MATLAB predefined names, specifying a single color for faces. See the `ColorSpec` reference page for more information on specifying color.
- `none` — Do not draw faces. Note that edges are drawn independently of faces.
- `flat` — The `CData` or `FaceVertexCData` property must contain one value per face and determines the color for each face in the patch. The color data at the first vertex determines the color of the entire face.
- `interp` — Bilinear interpolation of the color at each vertex determines the coloring of each face. The `CData` or `FaceVertexCData` property must contain one value per vertex.

## FaceLighting

`{none} | flat | gouraud | phong`

*Algorithm used for lighting calculations.* Selects the algorithm used to calculate the effect of `light` objects on patch faces.

- `none` — Lights do not affect the faces of this object.
- `flat` — The effect of light objects is uniform across the faces of the patch. Select this choice to view faceted objects.
- `gouraud` — The effect of light objects is calculated at the vertices and then linearly interpolated across the faces. Select this choice to view curved surfaces.

- phong — The effect of light objects is determined by interpolating the vertex normals across each face and calculating the reflectance at each pixel. Select this choice to view curved surfaces. Phong lighting generally produces better results than Gouraud lighting, but takes longer to render.

## Faces

m-by-n matrix

*Vertex connection defining each face.* Specifies which vertices in the Vertices property are connected. The Faces matrix defines  $m$  faces with up to  $n$  vertices each. Each row designates the connections for a single face, and the number of elements in that row that are not NaN defines the number of vertices for that face.

The Faces and Vertices properties provide an alternative way to specify a patch that can be more efficient than using  $x$ ,  $y$ , and  $z$  coordinates in most cases. For example, consider the following patch. It is composed of eight triangular faces defined by nine vertices.

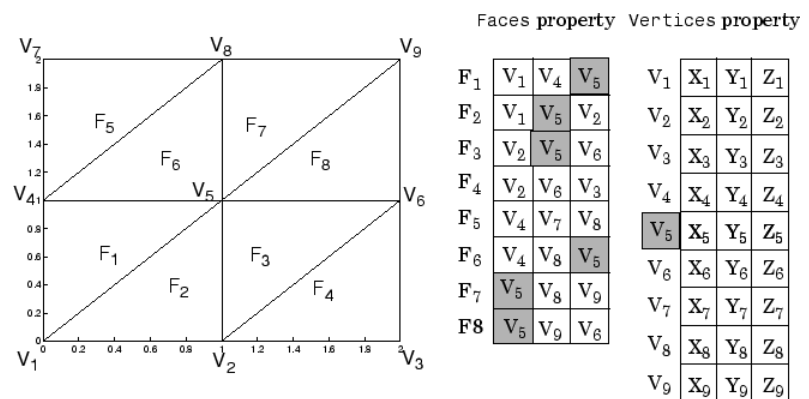

The corresponding Faces and Vertices properties are shown to the right of the patch. Note how some faces share vertices with other faces. For example, the fifth vertex (V5) is used six times,

# Patch Properties

---

once each by faces one, two, and three and six, seven, and eight. Without sharing vertices, this same patch requires 24 vertex definitions.

**FaceVertexAlphaData**  
m-by-1 matrix

*Face and vertex transparency data.* Specifies the transparency of patches that have been defined by the **Faces** and **Vertices** properties. The interpretation of the values specified for **FaceVertexAlphaData** depends on the dimensions of the data.

**FaceVertexAlphaData** can be one of the following:

- A single value, which applies the same transparency to the entire patch. The **FaceAlpha** property must be set to **flat**.
- An m-by-1 matrix (where m is the number of rows in the **Faces** property), which specifies one transparency value per face. The **FaceAlpha** property must be set to **flat**.
- An m-by-1 matrix (where m is the number of rows in the **Vertices** property), which specifies one transparency value per vertex. The **FaceAlpha** property must be set to **interp**.

The **AlphaDataMapping** property determines how MATLAB interprets the **FaceVertexAlphaData** property values.

**FaceVertexCData**  
matrix

*Face and vertex colors.* Specifies the color of patches defined by the **Faces** and **Vertices** properties. You must also set the values of the **FaceColor**, **EdgeColor**, **MarkerFaceColor**, or **MarkerEdgeColor** appropriately. The interpretation of the values specified for **FaceVertexCData** depends on the dimensions of the data.

For indexed colors, **FaceVertexCData** can be:

- A single value, which applies a single color to the entire patch.
- An  $n$ -by-1 matrix, where  $n$  is the number of rows in the `Faces` property, which specifies one color per face.
- An  $n$ -by-1 matrix, where  $n$  is the number of rows in the `Vertices` property, which specifies one color per vertex.

For true colors, `FaceVertexCData` can be:

- A 1-by-3 matrix, which applies a single color to the entire patch.
- An  $n$ -by-3 matrix, where  $n$  is the number of rows in the `Faces` property, which specifies one color per face.
- An  $n$ -by-3 matrix, where  $n$  is the number of rows in the `Vertices` property, which specifies one color per vertex.

The following diagram illustrates the various forms of the `FaceVertexCData` property for a patch having eight faces and nine vertices. The `CDataMapping` property determines how MATLAB interprets the `FaceVertexCData` property when you specify indexed colors.

# Patch Properties

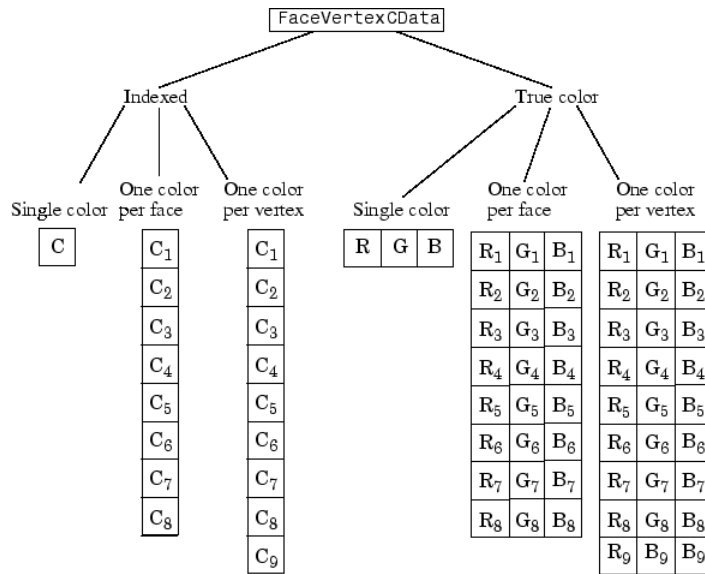

`HandleVisibility`  
{on} | callback | off

*Control access to object's handle.* Determines when an object's handle is visible in its parent's list of children. `HandleVisibility` is useful for preventing command-line users from accidentally drawing into or deleting a figure that contains only user interface devices (such as a dialog box).

- `on` — Handles are always visible.
- `callback` — Handles are visible from within callback routines or functions invoked by callback routines, but not from within functions invoked from the command line. This provides a means to protect GUIs from command-line users, while allowing callback routines to have access to object handles.
- `off` — Handles are invisible at all times. Use this option when a callback invokes a function that could damage the GUI (such

as evaluating a user-typed string). This option temporarily hides its own handles during the execution of that function.

When a handle is not visible in its parent's list of children, it cannot be returned by functions that obtain handles by searching the object hierarchy or querying handle properties. This includes `get`, `findobj`, `gca`, `gcf`, `gco`, `newplot`, `cla`, `clf`, and `close`.

When a handle's visibility is restricted using `callback` or `off`, the object's handle does not appear in its parent's `Children` property, figures do not appear in the root's `CurrentFigure` property, objects do not appear in the root's `CallbackObject` property or in the figure's `CurrentObject` property, and axes do not appear in their parent's `CurrentAxes` property.

You can set the root `ShowHiddenHandles` property to `on` to make all handles visible regardless of their `HandleVisibility` settings (this does not affect the values of the `HandleVisibility` properties).

Handles that are hidden are still valid. If you know an object's handle, you can `set` and `get` its properties, and pass it to any function that operates on handles.

`HitTest`  
`{on} | off`

*Selectable by mouse click.* Determines if the patch can become the current object (as returned by the `gco` command and the figure `CurrentObject` property) as a result of a mouse click on the patch. If `HitTest` is `off`, clicking the patch selects the object below it (which might be the axes containing it).

`Interruptible`  
`off | {on}`

*Callback routine interruption*

# Patch Properties

---

Controls whether MATLAB can interrupt an object's callback function when subsequent callbacks attempt to interrupt it.

For Graphics objects, the `Interruptible` property affects only the callbacks for the `ButtonDownFcn` property. A *running* callback is the currently executing callback. The *interrupting* callback is the callback that tries to interrupt the *running* callback. MATLAB handles both the callbacks based on the `Interruptible` property of the object of the *running* callback.

When the `Interruptible` property is set to:

- 'off', MATLAB finishes execution of the *running* callback without any interruptions
- 'on', these conditions apply:
  - If there is a `drawnow`, `figure`, `getframe`, `waitfor`, or `pause` command in the *running* callback, then MATLAB executes the *interrupting* callbacks which are already in the queue and returns to finish execution of the current callback.
  - If one of the above functions is not in the *running* callback, then MATLAB finishes execution of the current callback without any interruption.

`BusyAction` property of the object of interrupting callback determines whether the callback should be ignored or should be put in the queue.

Setting `Interruptible` property to on (default), allows a callback from other graphics objects to interrupt callback functions originating from this object.



---

**Note** MATLAB does not save the state of properties or the display when an interruption occurs. For example, the handle returned by the `gca` or `gcf` command may be changed as another callback is executed.

---

After the function that interrupts a callback completes, the callback resumes execution where it halted when interrupted. For more information, see “Control Callback Execution and Interruption”.

**LineStyle**

{-} | -- | : | -. | none

*Line style of the patch edges.*

## Line Style Specifiers Table

Specifier	Line Style
'-'	Solid line (default)
'--'	Dashed line
':'	Dotted line
'-.'	Dash-dot line
'none'	No line

Use **LineStyle** `none` when you want to place a marker at each point but do not want the points connected with a line (see the **Marker** property).

**LineWidth**

width in points

*Edge line width.* The width, in points, of the patch edges 1 point =  $\frac{1}{72}$  inch. The default value is 0.5 points.

# Patch Properties

---

## Marker

character (see table)

*Marker symbol.* Specifies marks that locate vertices. You can set values for the Marker property independently from the LineStyle property. For a list of supported marker symbols, see the following table.

### Marker Specifiers Table

Specifier	Marker Type
'+'	Plus sign
'o'	Circle
'*'	Asterisk
'.'	Point
'x'	Cross
'square' or 's'	Square
'diamond' or 'd'	Diamond
'^'	Upward-pointing triangle
'v'	Downward-pointing triangle
'>'	Right-pointing triangle
'<'	Left-pointing triangle
'pentagram' or 'p'	Five-pointed star (pentagram)
'hexagram' or 'h' ' ' '	Six-pointed star (hexagram)
'none'	No marker (default)

## MarkerEdgeColor

ColorSpec | none | {auto} | flat

*Marker edge color.* The color of the marker or the edge color for filled markers (circle, square, diamond, pentagram, hexagram, and the four triangles).

- `ColorSpec` — Defines the color to use.
- `none` — Specifies no color, which makes nonfilled markers invisible.
- `auto` — Sets `MarkerEdgeColor` to the same color as the `EdgeColor` property.
- `flat` — The color of each vertex controls the color of the marker that denotes it.

`MarkerFaceColor`

`ColorSpec` | `{none}` | `auto` | `flat`

*Marker face color.* The fill color for markers that are closed shapes (circle, square, diamond, pentagram, hexagram, and the four triangles).

- `ColorSpec` — Defines the color to use.
- `none` — Makes the interior of the marker transparent, allowing the background to show through.
- `auto` — Sets the fill color to the axes color, or the figure color, if the axes `Color` property is `none`.
- `flat` — The color of each vertex controls the color of the marker that denotes it.

`MarkerSize`

scalar

*Marker size.* Size of the marker in points. The default value is 6.

---

**Note** MATLAB draws the point marker (specified by the `'.'` symbol) at one-third the specified size.

---

# Patch Properties

---

## NormalMode

{auto} | manual

*MATLAB generated or user-specified normal vectors.*

- **auto** — MATLAB calculates vertex normals based on the coordinate data
- **manual** — If you specify your own vertex normals, MATLAB sets this property to **manual** and does not generate its own data.

See also the `VertexNormals` property.

## Parent

handle of axes, hggroup, or hgtransform

*Parent of patch object.* Contains the handle of the patch object's parent. The parent of a patch object is the axes, hggroup, or hgtransform object that contains it.

## Selected

on | {off}

*Is object selected?* When this property is on, MATLAB displays selection handles or a dashed box (depending on the number of faces) if the `SelectionHighlight` property is also on. You can, for example, define the `ButtonDownFcn` to set this property, allowing users to select the object with the mouse.

## SelectionHighlight

{on} | off

*Objects are highlighted when selected.* When the `Selected` property is on, MATLAB indicates the selected state by:

- Drawing handles at each vertex for a single-faced patch
- Drawing a dashed bounding box for a multifaced patch

When `SelectionHighlight` is off, MATLAB does not draw the indicators.

## `SpecularColorReflectance`

scalar in the range 0 to 1

*Color of specularly-reflected light.* When this property is 0, the color of the specularly-reflected light depends on both the color of the object from which it reflects and the color of the light source. When set to 1, the color of the specularly-reflected light depends only on the color of the light source (that is, the light object `Color` property). The proportions vary linearly for values in between.

## `SpecularExponent`

scalar  $\geq 1$

*Harshness of specular reflection.* Controls the size of the specular spot. Most materials have exponents in the range of 5 to 20.

## `SpecularStrength`

scalar  $\geq 0$  and  $\leq 1$

*Intensity of specular light.* Sets the intensity of the specular component of the light falling on the patch. Specular light comes from light objects in the axes.

You can also set the intensity of the ambient and diffuse components of the light on the patch object. See the `AmbientStrength` and `DiffuseStrength` properties. Also see the `material` function.

## `Tag`

string

*User-specified object label.* Provides a means to identify graphics objects with a user-specified label. The default is an empty string.

Use the `Tag` property and the `findobj` function to manipulate specific objects within a plotting hierarchy.

# Patch Properties

---

For example, suppose you use `patch` objects to create borders for a group of `uicontrol` objects and want to change the color of the borders in a `uicontrol`'s callback routine. Specify a `Tag` with the patch definition:

```
patch(X,Y,'k','Tag','PatchBorder')
```

Then use `findobj` in the `uicontrol`'s callback routine to obtain the handle of the patch and set its `FaceColor` property.

```
set(findobj('Tag','PatchBorder'),'FaceColor','w')
```

## Type

string (read-only)

*Class of the graphics object.* String that identifies the class of the graphics object. Use this property to find all objects of a given type within a plotting hierarchy. For patch objects, `Type` is always `'patch'`.

## UIContextMenu

handle of `uicontextmenu` object

*Associate a context menu with the patch.* Assign this property the handle of a `uicontextmenu` object created in the same figure as the patch. Use the `uicontextmenu` function to create the context menu. MATLAB displays the context menu whenever you right-click over the patch.

## UserData

matrix

*User-specified data.* Data you want to associate with the patch object. The default value is an empty array. MATLAB does not use this data, but you can access it using the `set` and `get` commands.

## VertexNormals

matrix

*Surface normal vectors.* Contains the vertex normals for the patch. MATLAB generates this data to perform lighting calculations. You can supply your own vertex normal data, even if it does not match the coordinate data. Use this property to produce interesting lighting effects.

## Vertices

matrix

*Vertex coordinates.* A matrix containing the  $x$ -,  $y$ -,  $z$ -coordinates for each vertex. See the Faces property for more information.

## Visible

{on} | off

*Patch object visibility.*

- on — All patches are visible.
- off — The patch is not visible, but still exists, and you can query and set its properties.

## XData

vector | matrix

*X-coordinates.* The  $x$ -coordinates of the patch vertices. If XData is a matrix, each column represents the  $x$ -coordinates of a single face of the patch. In this case, XData, YData, and ZData must have the same dimensions.

## YData

vector | matrix

*Y-coordinates.* The  $y$ -coordinates of the patch vertices. If YData is a matrix, each column represents the  $y$ -coordinates of a single face of the patch. In this case, XData, YData, and ZData must have the same dimensions.

## ZData

vector | matrix

# Patch Properties

---

*Z-coordinates.* The  $z$ -coordinates of the patch vertices. If ZData is a matrix, each column represents the  $z$ -coordinates of a single face of the patch. In this case, XData, YData, and ZData must have the same dimensions.

**See Also** `patch`



<b>Purpose</b>	View or change search path
<b>Alternatives</b>	As an alternative to the path function, use the Set Path dialog box.
<b>Syntax</b>	<pre>path path('newpath') path(path,'newpath') path('newpath',path) p = path</pre>
<b>Description</b>	<p>path displays the MATLAB search path, which is stored in pathdef.m.</p> <p>path('newpath') changes the search path to newpath, where newpath is a string array of folders.</p> <p>path(path,'newpath') adds the newpath folder to the end of the search path. If newpath is already on the search path, then path(path,'newpath') moves newpath to the end of the search path.</p> <p>path('newpath',path) adds the newpath folder to the top of the search path. If newpath is already on the search path, then path('newpath',path) moves newpath to the top of the search path. To add multiple folders in one statement, instead use addpath.</p> <p>p = path returns the search path to string variable p.</p>
<b>Examples</b>	<p>Display the search path:</p> <pre>path</pre> <p>MATLAB returns, for example</p> <pre>MATLABPATH  H:\My Documents\MATLAB C:\Program Files\MATLAB\R200nn\toolbox\matlab\general C:\Program Files\MATLAB\R200nn\toolbox\matlab\ops C:\Program Files\MATLAB\R200nn\toolbox\matlab\lang C:\Program Files\MATLAB\R200nn\toolbox\matlab\elmat</pre>

```
C:\Program Files\MATLAB\R200nn\toolbox\matlab\elfun
...
```

R200nn represents the folder for the MATLAB release, for example, R2009b.

Add a new folder to the search path on Microsoft Windows platforms:

```
path(path, 'c:/tools/goodstuff')
```

Add a new folder to the search path on UNIX<sup>5</sup> platforms:

```
path(path, '/home/tools/goodstuff')
```

Temporarily add the folder `my_files` to the search path, run `my_function` in `my_files`, then restore the previous search path:

```
p = path
path(p, 'my_files')
my_function
path(p)
```

## See Also

[addpath](#) | [cd](#) | [dir](#) | [genpath](#) | [matlabroot](#) | [pathsep](#) | [pathtool](#)  
| [rehash](#) | [restoredefaultpath](#) | [rmpath](#) | [savepath](#) | [startup](#)  
| [userpath](#) | [what](#)

## How To

- “What Is the MATLAB Search Path?”
- “Files and Folders that MATLAB Accesses”

5. UNIX is a registered trademark of The Open Group in the United States and other countries.

**Purpose** Save current search path to pathdef.m file

**Syntax** path2rc

**Description** path2rc runs savepath. The savepath function is replacing path2rc. Use savepath instead of path2rc and replace instances of path2rc with savepath.

# pathsep

---

**Purpose** Search path separator for current platform

**Syntax** `c = pathsep`

**Description** `c = pathsep` returns the search path separator character for this platform. The search path separator is the character that separates path names in the `pathdef.m` file, as returned by the `path` function. The character is a semicolon (;). For versions of MATLAB software earlier than version 7.7 (R2008b), the character on UNIX<sup>6</sup> platforms was a colon (:). Use `pathsep` to work programmatically with the content of the search path file.

**See Also** `fileparts` | `filesep` | `fullfile` | `path`

**How To**

- “What Is the MATLAB Search Path?”

6. UNIX is a registered trademark of The Open Group in the United States and other countries.

<b>Purpose</b>	Open Set Path dialog box to view and change search path
<b>Syntax</b>	<code>pathtool</code>
<b>Description</b>	<code>pathtool</code> opens the Set Path dialog box, a graphical user interface you use to view and modify the MATLAB search path.

# pathtool

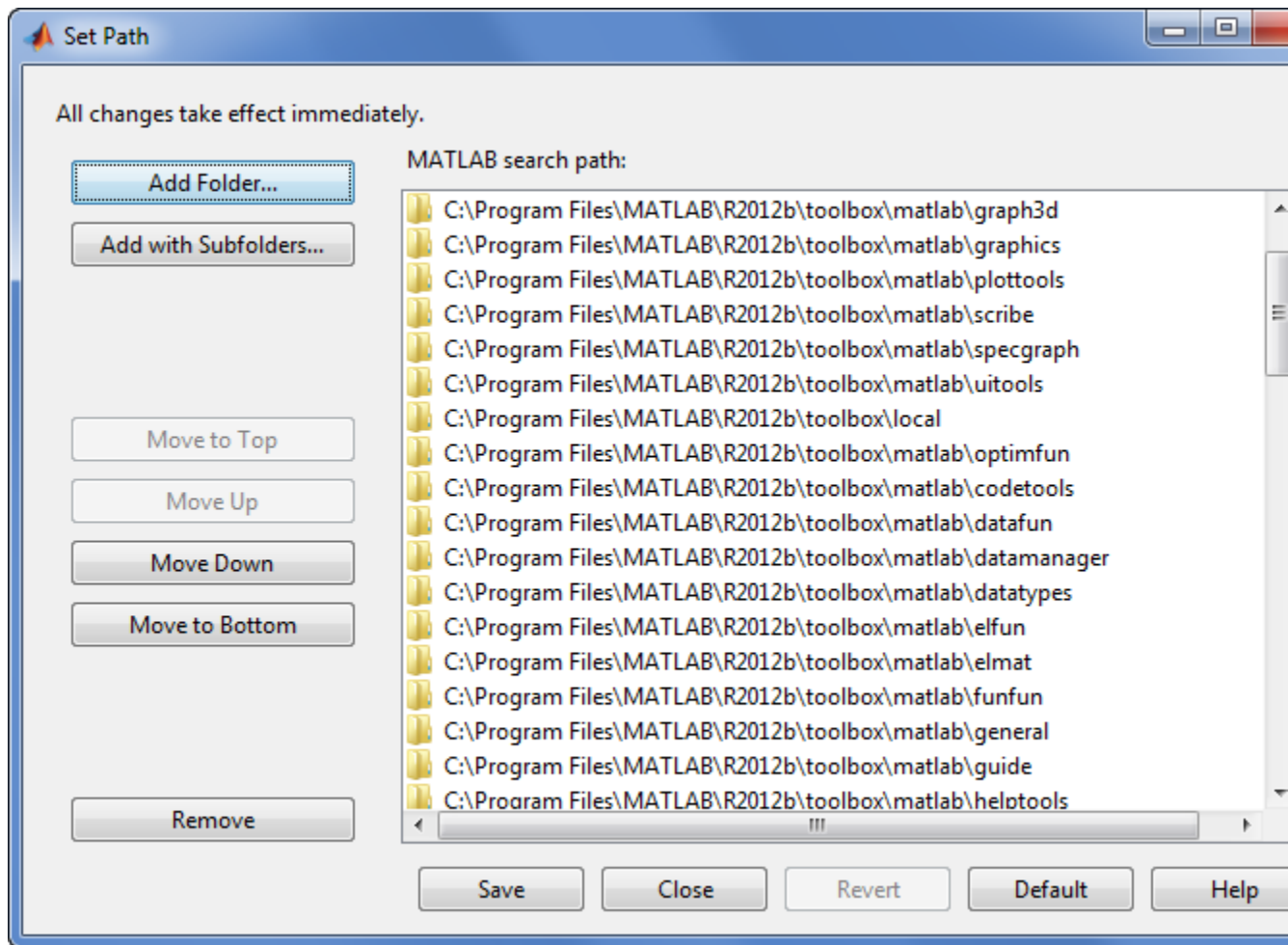

## See Also

`addpath` | `cd` | `dir` | `genpath` | `matlabroot` | `path` | `pathsep` | `rehash`  
| `restoredefaultpath` | `rmpath` | `savepath` | `startup` | `what`

## How To

- “What Is the MATLAB Search Path?”

**Purpose** Halt execution temporarily

**Syntax**

```

pause
pause(n)
pause on
pause off
pause query
state = pause('query')
oldstate = pause(newstate)

```

**Description** `pause`, by itself, causes the currently executing function to stop and wait for you to press any key before continuing. Pausing must be enabled for this to take effect. (See `pause on`, below). `pause` without arguments also blocks execution of Simulink models, but not repainting of them.

`pause(n)` pauses execution for `n` seconds before continuing, where `n` is any nonnegative real number. Pausing must be enabled for this to take effect.

Typing `pause(inf)` puts you into an infinite loop. To return to the MATLAB prompt, type **Ctrl+C**.

`pause on` enables the pausing of MATLAB execution via the `pause` and `pause(n)` commands. Pausing remains enabled until you enter `pause off` in your function or at the command line.

`pause off` disables the pausing of MATLAB execution via the `pause` and `pause(n)` commands. This allows normally interactive scripts to run unattended. Pausing remains disabled until you enter `pause on` in your function or at the command line, or start a new MATLAB session.

`pause query` displays 'on' if pausing is currently enabled. Otherwise, it displays 'off'.

`state = pause('query')` returns 'on' in character array `state` if pausing is currently enabled. Otherwise, the value of `state` is 'off'.

`oldstate = pause(newstate)`, enables or disables pausing, depending on the 'on' or 'off' value in `newstate`, and returns the former setting (also either 'on' or 'off') in character array `oldstate`.

# pause

---

## Tips

The accuracy of `pause` is subject to the scheduling resolution of the operating system you are using, and also to other system activity. It cannot be guaranteed with 100% confidence. Asking for finer resolutions shows higher relative error.

While MATLAB is paused, the following continue to execute:

- Repainting of figure windows, Simulink block diagrams, and Java windows
- HG callbacks from figure windows
- Event handling from Java windows

## See Also

`keyboard` | `input` | `drawnow`



**Purpose** Set or query plot box aspect ratio

**Syntax**

```
pbaspect
pbaspect([aspect_ratio])
pbaspect('mode')
pbaspect('auto')
pbaspect('manual')
pbaspect(axes_handle,...)
```

**Description** The plot box aspect ratio determines the relative size of the  $x$ -,  $y$ -, and  $z$ -axes.

`pbaspect` with no arguments returns the plot box aspect ratio of the current axes.

`pbaspect([aspect_ratio])` sets the plot box aspect ratio in the current axes to the specified value. Specify the aspect ratio as three relative values representing the ratio of the  $x$ -,  $y$ -, and  $z$ -axes size. For example, a value of `[1 1 1]` (the default) means the plot box is a cube (although with stretch-to-fill enabled, it may not appear as a cube). See [Tips](#).

`pbaspect('mode')` returns the current value of the plot box aspect ratio mode, which can be either `auto` (the default) or `manual`. See [Remarks](#).

`pbaspect('auto')` sets the plot box aspect ratio mode to `auto`.

`pbaspect('manual')` sets the plot box aspect ratio mode to `manual`.

`pbaspect(axes_handle,...)` performs the set or query on the axes identified by the first argument, `axes_handle`. If you do not specify an axes handle, `pbaspect` operates on the current axes.

**Tips** `pbaspect` sets or queries values of the axes object `PlotBoxAspectRatio` and `PlotBoxAspectRatioMode` properties.

When the plot box aspect ratio mode is `auto`, the MATLAB software sets the ratio to `[1 1 1]`, but may change it to accommodate manual settings of the data aspect ratio, camera view angle, or axis limits. See the axes `DataAspectRatio` property for a table listing the interactions between various properties.

Setting a value for the plot box aspect ratio or setting the plot box aspect ratio mode to `manual` disables the MATLAB stretch-to-fill feature (stretching of the axes to fit the window). This means setting the plot box aspect ratio to its current value,

```
pbaspect(pbaspect)
```

can cause a change in the way the graphs look. See the Remarks section of the `axes` reference description, “Axes Aspect Ratio Properties” in the 3-D Visualization manual, and “Setting Aspect Ratio” in the MATLAB Graphics manual for a discussion of stretch-to-fill.

## Examples

### Query Plot Box Aspect Ratio

Plot the function  $z = xe^{-x^2-y^2}$  over the range  $-2 \leq x \leq 2$  and  $-2 \leq y \leq 2$ .

```
[x,y] = meshgrid([-2:.2:2]);
z = x.*exp(-x.^2 - y.^2);
surf(x,y,z)
```

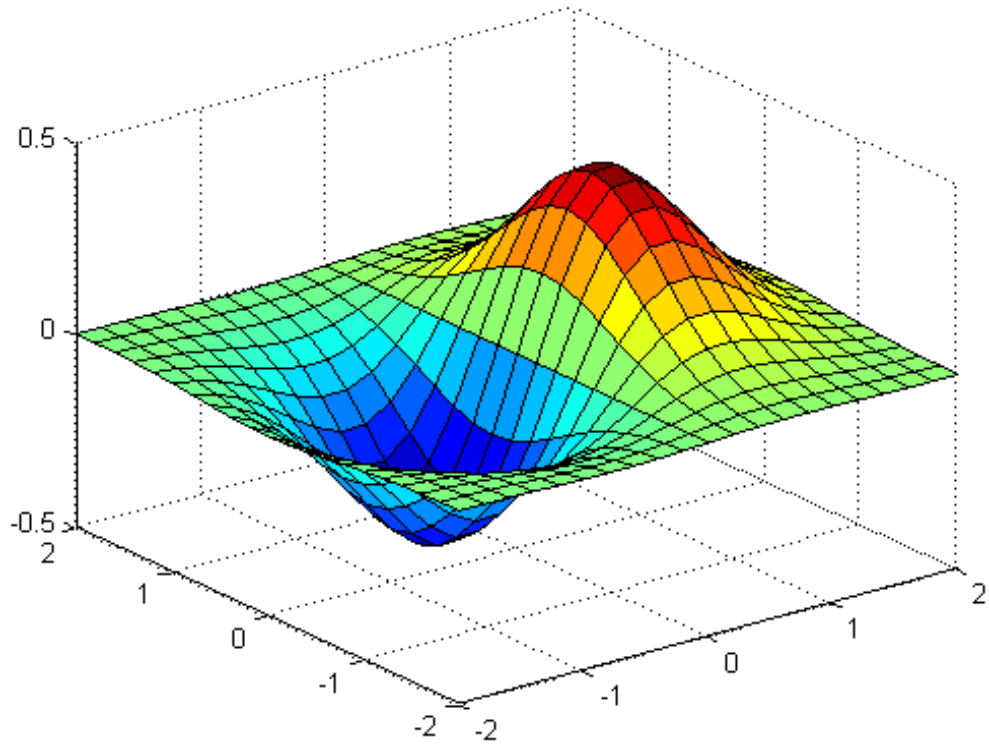

Query the plot box aspect ratio to show that the plot box is square.

```
plotboxaspect = pbaspect
```

```
plotboxaspect =
```

```
 1 1 1
```

# pbaspect

---

Change the data aspect ratio.

```
daspect([1,1,1])
```

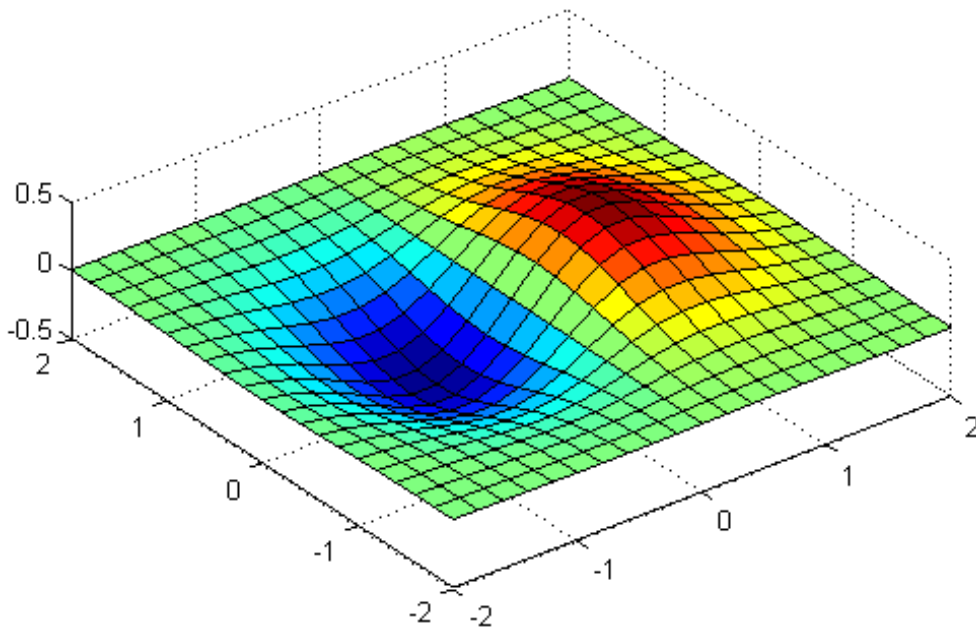

Query the plot box aspect ratio to show how it changes to accommodate the specified data aspect ratio.

```
plotboxaspect = pbaspect
```

```
plotboxaspect =
 4 4 1
```

Make the plot box square again by changing the plot box aspect ratio to [1,1,1].

```
pbaspect([1,1,1])
```

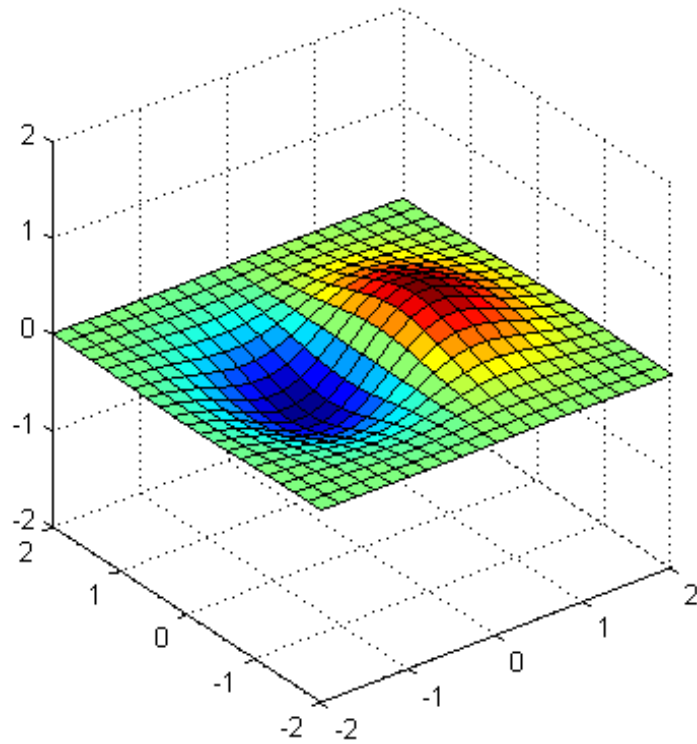

# pbaspect

---

## See Also

`axis` | `daspect` | `xlim` | `ylim` | `zlim` | `DataAspectRatio` | `PlotBoxAspectRatio` | `XLim` | `YLim` | `ZLim`

## How To

- [Setting Aspect Ratio](#)
- [Axes Aspect Ratio Properties](#)

**Purpose** Preconditioned conjugate gradients method

**Syntax**

```
x = pcg(A,b)
pcg(A,b,tol)
pcg(A,b,tol,maxit)
pcg(A,b,tol,maxit,M)
pcg(A,b,tol,maxit,M1,M2)
pcg(A,b,tol,maxit,M1,M2,x0)
[x,flag] = pcg(A,b,...)
[x,flag,relres] = pcg(A,b,...)
[x,flag,relres,iter] = pcg(A,b,...)
[x,flag,relres,iter,resvec] = pcg(A,b,...)
```

**Description** `x = pcg(A,b)` attempts to solve the system of linear equations  $A*x=b$  for  $x$ . The  $n$ -by- $n$  coefficient matrix  $A$  must be symmetric and positive definite, and should also be large and sparse. The column vector  $b$  must have length  $n$ . You also can specify  $A$  to be a function handle, `afun`, such that `afun(x)` returns  $A*x$ .

“Parameterizing Functions” explains how to provide additional parameters to the function `afun`, as well as the preconditioner function `mfun` described below, if necessary.

If `pcg` converges, a message to that effect is displayed. If `pcg` fails to converge after the maximum number of iterations or halts for any reason, a warning message is printed displaying the relative residual  $\text{norm}(b-A*x)/\text{norm}(b)$  and the iteration number at which the method stopped or failed.

`pcg(A,b,tol)` specifies the tolerance of the method. If `tol` is `[]`, then `pcg` uses the default,  $1e-6$ .

`pcg(A,b,tol,maxit)` specifies the maximum number of iterations. If `maxit` is `[]`, then `pcg` uses the default,  $\min(n,20)$ .

`pcg(A,b,tol,maxit,M)` and `pcg(A,b,tol,maxit,M1,M2)` use symmetric positive definite preconditioner  $M$  or  $M = M1*M2$  and effectively solve the system  $\text{inv}(M)*A*x = \text{inv}(M)*b$  for  $x$ . If  $M$  is `[]`

then `pcg` applies no preconditioner. `M` can be a function handle `mfun` such that `mfun(x)` returns  $M \backslash x$ .

`pcg(A,b,tol,maxit,M1,M2,x0)` specifies the initial guess. If `x0` is `[]`, then `pcg` uses the default, an all-zero vector.

`[x,flag] = pcg(A,b,...)` also returns a convergence flag.

Flag	Convergence
0	<code>pcg</code> converged to the desired tolerance <code>tol</code> within <code>maxit</code> iterations.
1	<code>pcg</code> iterated <code>maxit</code> times but did not converge.
2	Preconditioner <code>M</code> was ill-conditioned.
3	<code>pcg</code> stagnated. (Two consecutive iterates were the same.)
4	One of the scalar quantities calculated during <code>pcg</code> became too small or too large to continue computing.

Whenever `flag` is not 0, the solution `x` returned is that with minimal norm residual computed over all the iterations. No messages are displayed if the `flag` output is specified.

`[x,flag,relres] = pcg(A,b,...)` also returns the relative residual  $\text{norm}(b-A*x)/\text{norm}(b)$ . If `flag` is 0, `relres`  $\leq$  `tol`.

`[x,flag,relres,iter] = pcg(A,b,...)` also returns the iteration number at which `x` was computed, where  $0 \leq \text{iter} \leq \text{maxit}$ .

`[x,flag,relres,iter,resvec] = pcg(A,b,...)` also returns a vector of the residual norms at each iteration including  $\text{norm}(b-A*x0)$ .

## Examples

### Using `pcg` with Large Matrices

This example shows how to use `pcg` with a matrix input and with a function handle.

```
n1 = 21;
A = gallery('moler',n1);
b1 = sum(A,2);
```



```

tol = 1e-6;
maxit = 15;
M1 = spdiags((1:n1)',0,n1,n1);
[x1,flag1,rr1,iter1,rv1] = pcg(A,b1,tol,maxit,M1);

```

Alternatively, you can use the following function in place of the matrix A:

```

function y = applyMoler(x)
y = x;
y(end-1:-1:1) = y(end-1:-1:1) - cumsum(y(end:-1:2));
y(2:end) = y(2:end) - cumsum(y(1:end-1));

```

By using this function, you can solve larger systems more efficiently as there is no need to store the entire matrix A:

```

n2 = 21;
b2 = applyMoler(ones(n2,1));
tol = 1e-6;
maxit = 15;
M2 = spdiags((1:n2)',0,n2,n2);
[x2,flag2,rr2,iter2,rv2] = pcg(@applyMoler,b2,tol,maxit,M2);

```

### Using pcg with a Preconditioner

This example demonstrates how to use a preconditioner matrix with `pcg`.

Create an input matrix and try to solve the system with `pcg`.

```

A = delsq(numgrid('S',100));
b = ones(size(A,1),1);
[x0,f10,rr0,it0,rv0] = pcg(A,b,1e-8,100);

```

`f10` is 1 because `pcg` does not converge to the requested tolerance of  $1e-8$  within the requested maximum 100 iterations. A preconditioner can make the system converge more quickly.

Use `ichol` with only one input argument to construct an incomplete Cholesky factorization with zero fill.

```
L = ichol(A);
[x1,f11,rr1,it1,rv1] = pcg(A,b,1e-8,100,L,L');
```

f11 is 0 because pcg drives the relative residual to  $9.8e-09$  (the value of rr1) which is less than the requested tolerance of  $1e-8$  at the seventy-seventh iteration (the value of it1) when preconditioned by the zero-fill incomplete Cholesky factorization.  $rv1(1) = \text{norm}(b)$  and  $rv1(78) = \text{norm}(b-A*x1)$ .

The previous matrix represents the discretization of the Laplacian on a 100x100 grid with Dirichlet boundary conditions. This means that a modified incomplete Cholesky preconditioner might perform even better.

Use the michol option to create a modified incomplete Cholesky preconditioner.

```
L = ichol(A,struct('michol','on'));
[x2,f12,rr2,it2,rv2] = pcg(A,b,1e-8,100,L,L');
```

In this case you attain convergence in only forty-seven iterations.

You can see how the preconditioners affect the rate of convergence of pcg by plotting each of the residual histories starting from the initial estimate (iterate number 0).

```
figure;
semilogy(0:it0,rv0/norm(b),'b.');
```

```
hold on;
semilogy(0:it1,rv1/norm(b),'r.');
```

```
semilogy(0:it2,rv2/norm(b),'k.');
```

```
legend('No Preconditioner','IC(0)','MIC(0)');
```

```
xlabel('iteration number');
```

```
ylabel('relative residual');
```

```
hold off;
```

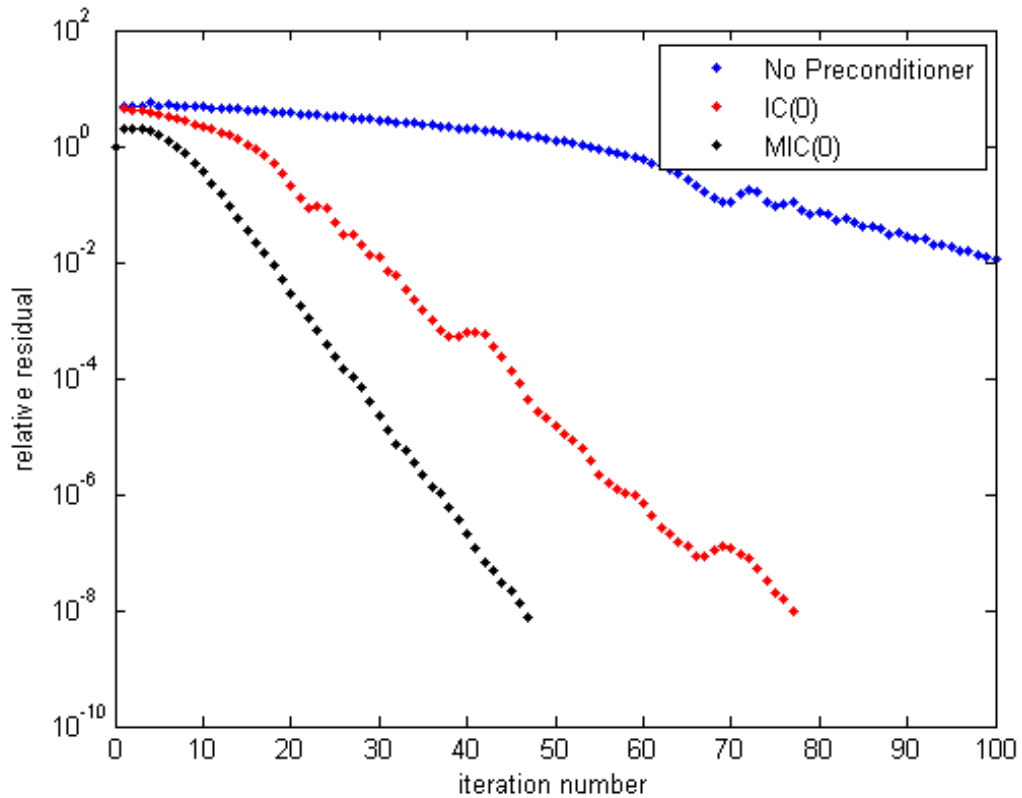

## References

[1] Barrett, R., M. Berry, T. F. Chan, et al., *Templates for the Solution of Linear Systems: Building Blocks for Iterative Methods*, SIAM, Philadelphia, 1994.

## See Also

`bicg` | `bicgstab` | `cgs` | `function_handle` | `gmres` | `ichol` | `lsqr` | `minres` | `qmr` | `symmlq` | `mldivide`

# pchip

---

**Purpose** Piecewise Cubic Hermite Interpolating Polynomial (PCHIP)

**Syntax**  
`yi = pchip(x,y,xi)`  
`pp = pchip(x,y)`

**Description** `yi = pchip(x,y,xi)` returns vector `yi` containing elements corresponding to the elements of `xi` and determined by piecewise cubic interpolation within vectors `x` and `y`. The vector `x` specifies the points at which the data `y` is given. If `y` is a matrix, then the interpolation is performed for each column of `y` and `yi` is `length(xi)-by-size(y,2)`.

`pp = pchip(x,y)` returns a piecewise polynomial structure for use by `ppval`. `x` can be a row or column vector. `y` is a row or column vector of the same length as `x`, or a matrix with `length(x)` columns.

`pchip` finds values of an underlying interpolating function  $P(x)$  at intermediate points, such that:

- On each subinterval  $x_k \leq x \leq x_{k+1}$ ,  $P(x)$  is the cubic Hermite interpolant to the given values and certain slopes at the two endpoints.
- $P(x)$  interpolates  $y$ , i.e.,  $P(x_j) = y_j$ , and the first derivative  $P'(x)$  is continuous.  $P''(x)$  is probably not continuous; there may be jumps at the  $x_j$ .
- The slopes at the  $x_j$  are chosen in such a way that  $P(x)$  preserves the shape of the data and respects monotonicity. This means that, on intervals where the data are monotonic, so is  $P(x)$ ; at points where the data has a local extremum, so does  $P(x)$ .

---

**Note** If  $y$  is a matrix,  $P(x)$  satisfies the above for each column of  $y$ .

---

**Tips**

`spline` constructs  $S(x)$  in almost the same way `pchip` constructs  $P(x)$ . However, `spline` chooses the slopes at the  $x_j$  differently, namely to make even  $S''(x)$  continuous. This has the following effects:

- `spline` produces a smoother result, i.e.  $S''(x)$  is continuous.
- `spline` produces a more accurate result if the data consists of values of a smooth function.
- `pchip` has no overshoots and less oscillation if the data are not smooth.
- `pchip` is less expensive to set up.
- The two are equally expensive to evaluate.

**Examples****Data Interpolation Using `spline` and `pchip`**

```
x = -3:3;
y = [-1 -1 -1 0 1 1 1];
t = -3:.01:3;
p = pchip(x,y,t);
s = spline(x,y,t);
plot(x,y,'o',t,p,'-',t,s,'-.')
legend('data','pchip','spline',4)
```

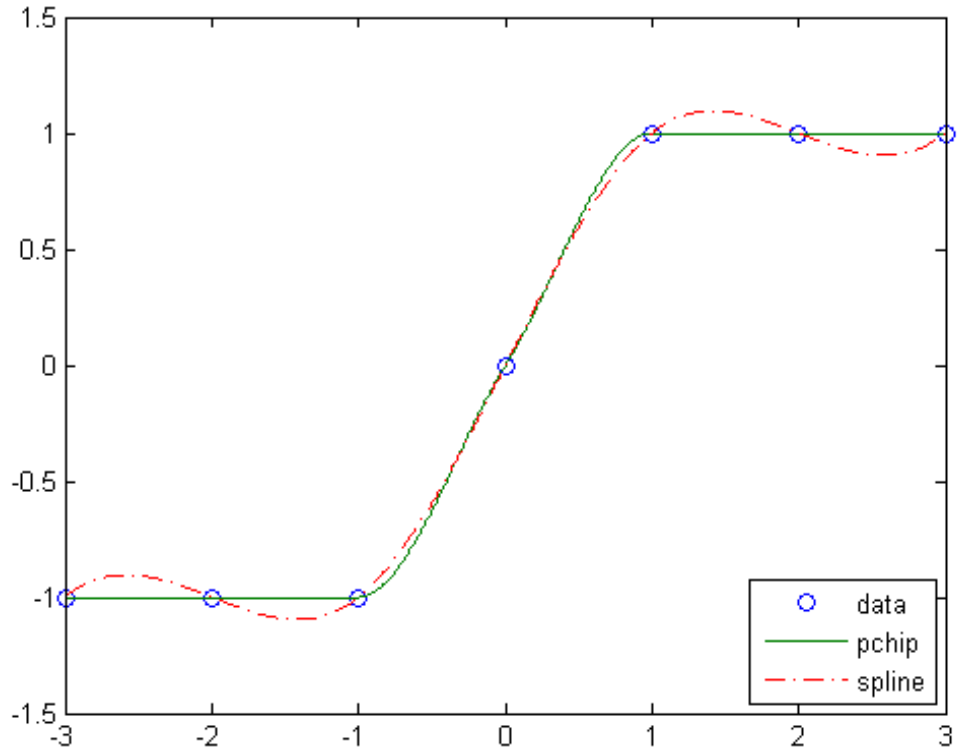

## References

[1] Fritsch, F. N. and R. E. Carlson, "Monotone Piecewise Cubic Interpolation," *SIAM J. Numerical Analysis*, Vol. 17, 1980, pp.238-246.

[2] Kahaner, David, Cleve Moler, Stephen Nash, *Numerical Methods and Software*, Prentice Hall, 1988.

## See Also

[interp1](#) | [spline](#) | [ppval](#)

**Purpose** Create protected function file

**Syntax**

```
pcode(fun)
pcode(fun1,...,funN)
pcode(fun, '-inplace')
```

**Description** `pcode(fun)` obfuscates the code in `fun.m` and produces a file called `fun.p`, known as a P-file. If `fun` is a folder, then all the script or function files in that folder are obfuscated in P-files. MATLAB creates the P-files in the current folder. The original `.m` file or folder can be anywhere on the search path.

`pcode(fun1,...,funN)` creates N P-files from the listed files. If any inputs are folders, then MATLAB creates a P-file for every `.m` file the folders contain.

`pcode(fun, '-inplace')` creates P-files in the same folder as the script or function files.

---

**Note** The `pcode` function *obfuscates* your `.m` files, it does not *encrypt* them. While the content in a `.p` file is difficult to understand, it should not be considered secure. It is not recommended that you P-code files to protect your intellectual property.

---

## Tips

- The `pcode` algorithm was redesigned in MATLAB 7.5 (Release R2007b). You can run older P-files in any current version of MATLAB; however, upcoming releases will not run P-files created before version 7.5. Files generated in 7.5, or later versions, cannot run in MATLAB 7.4 or earlier.
- When obfuscating all files in a folder, `pcode` does not obfuscate any files within subfolders.
- A P-file takes precedence over the corresponding `.m` file for execution, even after modifications to the `.m` file.

- MATLAB does not display any of the help comments that might be in the original `.m` file.

## Input Arguments

### **fun**

MATLAB file or directory containing MATLAB files. If `fun` resides within a package and/or class folder, then `pcode` creates the same package and/or class structure to house the resulting P-files.

An input argument with no file extension and that is not a folder must be a function in the MATLAB path or in the current folder.

When using wild cards `*`, `pcode` ignores all files with extensions other than `.m`.

## Examples

### **P-Coding Multiple Files**

Convert selected files from the `sparfun` folder into P-files.

Create a temporary folder and define an existing path to `.m` files.

```
tmp = tempname;
mkdir(tmp);
cd(tmp);
fun = fullfile(matlabroot, 'toolbox', 'matlab', 'sparfun', 'spr*.m');
```

Create the P-files.

```
pcode(fun)
dir(tmp)

.
.. sprand.p sprandn.p sprandsym.p sprank.p
```

The temporary folder now contains encoded P-files.

### **P-Coding Files That Belong to a Package and/or Class**

Generate P-files from input files that are part of a package and/or class. This example uses an existing MATLAB example class.

Define `funclass` as an existing a class folder that contains `.m` files.



```
funclass = fullfile(docroot, 'techdoc', 'matlab_oop', ...
 'examples', '@BankAccount')
dir(funclass)
```

```
funclass =
C:\Program Files\MATLAB\R2013a\help\techdoc\matlab_oop\examples\@BankAccount

. .. BankAccount.m
```

Create a temporary folder. This folder has no package or class structure at this time.

```
tmp = tempname;
mkdir(tmp);
cd(tmp);
dir(tmp)
```

```
. ..
```

Create a P-file for every .m file in the path funclass. Because the input files are part of a package and/or class, MATLAB creates a folder structure so that the output file belongs to the same package and/or class.

```
pcode(funclass)
dir(tmp)
```

```
. .. @BankAccount
```

You see that the P-file resides in the same folder structure.

```
dir('@BankAccount')

. .. BankAccount.p
```

## P-Coding In Place

Generate P-files in the same folder as the input files using the option `inplace`

Copy several MATLAB files to a temporary folder.

```
fun = fullfile(matlabroot, 'toolbox', 'matlab', 'sparfun', 'spr*.m');
tmp = tempname;
mkdir(tmp);
copyfile(fun, tmp)
dir(tmp)
```

```
. .. sprand.m sprandn.m sprandsym.m sprank.m
```

Create P-files in the same folder as the original `.m` files.

```
pcode(tmp, '-inplace')
dir(tmp)
```

```
. sprand.m sprandn.m sprandsym.m sprank.m
.. sprand.p sprandn.p sprandsym.p sprank.p
```

## See Also

`matlab.codetools.requiredFilesAndProducts`

## Concepts

- “Protect Your Source Code”

**Purpose** Pseudocolor (checkerboard) plot



**Syntax**

```
pcolor(C)
pcolor(X,Y,C)
pcolor(axes_handles,...)
h = pcolor(...)
```

**Description** A pseudocolor plot is a rectangular array of cells with colors determined by **C**. MATLAB creates a pseudocolor plot using each set of four adjacent points in **C** to define a surface rectangle (i.e., cell).

The default shading is `faceted`, which colors each cell with a single color. The last row and column of **C** are not used in this case. With shading `interp`, each cell is colored by bilinear interpolation of the colors at its four vertices, using all elements of **C**.

The minimum and maximum elements of **C** are assigned the first and last colors in the colormap. Colors for the remaining elements in **C** are determined by a linear mapping from value to colormap element.

`pcolor(C)` draws a pseudocolor plot. The elements of **C** are linearly mapped to an index into the current colormap. The mapping from **C** to the current colormap is defined by `colormap` and `caxis`.

`pcolor(X,Y,C)` draws a pseudocolor plot of the elements of **C** at the locations specified by **X** and **Y**. The plot is a logically rectangular, two-dimensional grid with vertices at the points  $[X(i,j), Y(i,j)]$ . **X** and **Y** are vectors or matrices that specify the spacing of the grid lines. If **X** and **Y** are vectors, **X** corresponds to the columns of **C** and **Y** corresponds to the rows. If **X** and **Y** are matrices, they must be the same size as **C**.

`pcolor(axes_handles,...)` plots into the axes with handle `axes_handle` instead of the current axes (`gca`).

`h = pcolor(...)` returns a handle to a surface graphics object.

## Tips

A pseudocolor plot is a flat surface plot viewed from above. `pcolor(X,Y,C)` is the same as viewing `surf(X,Y,zeros(size(X)),C)` using `view([0 90])`.

When you use `shading faceted` or `shading flat`, the constant color of each cell is the color associated with the corner having the smallest  $x$ - $y$  coordinates. Therefore, `C(i,j)` determines the color of the cell in the  $i$ th row and  $j$ th column. The last row and column of `C` are not used.

When you use `shading interp`, each cell's color results from a bilinear interpolation of the colors at its four vertices, and all elements of `C` are used.

## Examples

A Hadamard matrix has elements that are +1 and -1. A colormap with only two entries is appropriate when displaying a pseudocolor plot of this matrix.

```
pcolor(hadamard(20))
colormap(gray(2))
axis ij
axis square
```

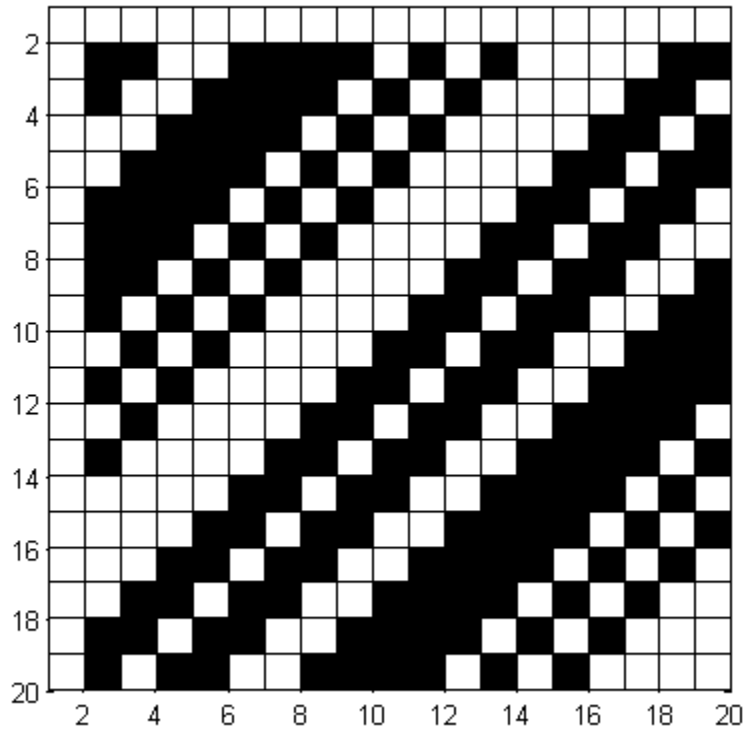

A simple color wheel illustrates a polar coordinate system.

```
n = 6;
r = (0:n)'/n;
theta = pi*(-n:n)/n;
X = r*cos(theta);
Y = r*sin(theta);
C = r*cos(2*theta);
pcolor(X,Y,C)
```

axis equal tight

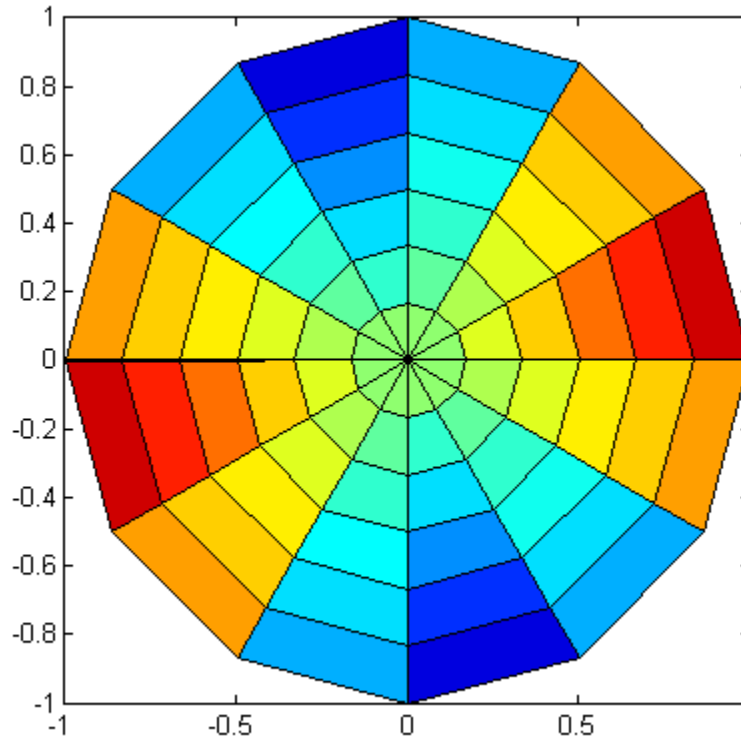

## Algorithms

The number of vertex colors for `pcolor(C)` is the same as the number of cells for `image(C)`. `pcolor` differs from `image` in that `pcolor(C)` specifies the colors of vertices, which are scaled to fit the colormap; changing the axes `clim` property changes this color mapping. `image(C)` specifies the colors of cells and directly indexes into the colormap without scaling. Additionally, `pcolor(X,Y,C)` can produce parametric grids, which is not possible with `image`.

**See Also**

[caxis](#) | [image](#) | [mesh](#) | [shading](#) | [surf](#) | [view](#)

# pdepe

---

## Purpose

Solve initial-boundary value problems for parabolic-elliptic PDEs in 1-D

## Syntax

```
sol = pdepe(m,pdefun,icfun,bcfun,xmesh,tspan)
sol = pdepe(m,pdefun,icfun,bcfun,xmesh,tspan,options)
[sol,tsol,sole,te,ie] = pdepe(m,pdefun,icfun,bcfun,xmesh,tspan,
 options)
```

## Arguments

m	A parameter corresponding to the symmetry of the problem. m can be slab = 0, cylindrical = 1, or spherical = 2.
pdefun	A handle to a function that defines the components of the PDE.
icfun	A handle to a function that defines the initial conditions.
bcfun	A handle to a function that defines the boundary conditions.
xmesh	A vector [x0, x1, ..., xn] specifying the points at which a numerical solution is requested for every value in tspan. The elements of xmesh must satisfy $x_0 < x_1 < \dots < x_n$ . The length of xmesh must be $\geq 3$ .
tspan	A vector [t0, t1, ..., tf] specifying the points at which a solution is requested for every value in xmesh. The elements of tspan must satisfy $t_0 < t_1 < \dots < t_f$ . The length of tspan must be $\geq 3$ .
options	Some options of the underlying ODE solver are available in pdepe: RelTol, AbsTol, NormControl, InitialStep, MaxStep, and Events. In most cases, default values for these options provide satisfactory solutions. See odeset for details.



**Description**

`sol = pdepe(m,pdefun,icfun,bcfun,xmesh,tspan)` solves initial-boundary value problems for systems of parabolic and elliptic PDEs in the one space variable  $x$  and time  $t$ . `pdefun`, `icfun`, and `bcfun` are function handles. See the `function_handle` reference page for more information. The ordinary differential equations (ODEs) resulting from discretization in space are integrated to obtain approximate solutions at times specified in `tspan`. The `pdepe` function returns values of the solution on a mesh provided in `xmesh`.

“Parameterizing Functions” explains how to provide additional parameters to the functions `pdefun`, `icfun`, or `bcfun`, if necessary.

`pdepe` solves PDEs of the form:

$$c\left(x,t,u,\frac{\partial u}{\partial x}\right)\frac{\partial u}{\partial t} = x^{-m}\frac{\partial}{\partial x}\left(x^m f\left(x,t,u,\frac{\partial u}{\partial x}\right)\right) + s\left(x,t,u,\frac{\partial u}{\partial x}\right) \quad (1-4)$$

The PDEs hold for  $t_0 \leq t \leq t_f$  and  $a \leq x \leq b$ . The interval  $[a,b]$  must be finite.  $m$  can be 0, 1, or 2, corresponding to slab, cylindrical, or spherical symmetry, respectively. If  $m > 0$ , then  $a$  must be  $\geq 0$ .

In Equation 1-4,  $f(x,t,u,\partial u/\partial x)$  is a flux term and  $s(x,t,u,\partial u/\partial x)$  is a source term. The coupling of the partial derivatives with respect to time is restricted to multiplication by a diagonal matrix  $c(x,t,u,\partial u/\partial x)$ . The diagonal elements of this matrix are either identically zero or positive. An element that is identically zero corresponds to an elliptic equation and otherwise to a parabolic equation. There must be at least one parabolic equation. An element of  $c$  that corresponds to a parabolic equation can vanish at isolated values of  $x$  if those values of  $x$  are mesh points. Discontinuities in  $c$  and/or  $s$  due to material interfaces are permitted provided that a mesh point is placed at each interface.

For  $t = t_0$  and all  $x$ , the solution components satisfy initial conditions of the form

$$u(x,t_0) = u_0(x) \quad (1-5)$$

For all  $t$  and either  $x = a$  or  $x = b$ , the solution components satisfy a boundary condition of the form

$$p(x,t,u) + q(x,t)f\left(x,t,u,\frac{\partial u}{\partial x}\right) = 0 \quad (1-6)$$

Elements of  $q$  are either identically zero or never zero. Note that the boundary conditions are expressed in terms of the flux  $f$  rather than  $\partial u/\partial x$ . Also, of the two coefficients, only  $p$  can depend on  $u$ .

In the call `sol = pdepe(m,pdefun,icfun,bcfun,xmesh,tspan)`:

- $m$  corresponds to  $m$ .
- `xmesh(1)` and `xmesh(end)` correspond to  $a$  and  $b$ .
- `tspan(1)` and `tspan(end)` correspond to  $t_0$  and  $t_f$ .
- `pdefun` computes the terms  $c$ ,  $f$ , and  $s$  (Equation 1-4). It has the form

$$[c,f,s] = \text{pdefun}(x,t,u,\text{dudx})$$

The input arguments are scalars  $x$  and  $t$  and vectors  $u$  and  $\text{dudx}$  that approximate the solution  $u$  and its partial derivative with respect to  $x$ , respectively.  $c$ ,  $f$ , and  $s$  are column vectors.  $c$  stores the diagonal elements of the matrix  $c$  (Equation 1-4).

- `icfun` evaluates the initial conditions. It has the form

$$u = \text{icfun}(x)$$

When called with an argument  $x$ , `icfun` evaluates and returns the initial values of the solution components at  $x$  in the column vector  $u$ .

- `bcfun` evaluates the terms  $p$  and  $q$  of the boundary conditions (Equation 1-6). It has the form

$$[p1,q1,pr,qr] = \text{bcfun}(x1,u1,xr,ur,t)$$

$u1$  is the approximate solution at the left boundary  $x1 = a$  and  $ur$  is the approximate solution at the right boundary  $xr = b$ .  $p1$  and  $q1$  are column vectors corresponding to  $p$  and  $q$  evaluated at  $x1$ , similarly  $pr$  and  $qr$  correspond to  $xr$ . When  $m > 0$  and  $a = 0$ , boundedness of the solution near  $x = 0$  requires that the flux  $f$  vanish at  $a = 0$ . `pdepe`

imposes this boundary condition automatically and it ignores values returned in `pl` and `ql`.

`pdepe` returns the solution as a multidimensional array `sol`.

$u_i = \text{ui} = \text{sol}(:, :, i)$  is an approximation to the  $i$ th component of the solution vector  $u$ . The element  $\text{ui}(j, k) = \text{sol}(j, k, i)$  approximates  $u_i$  at  $(t, x) = (\text{tspan}(j), \text{xmesh}(k))$ .

$\text{ui} = \text{sol}(j, :, i)$  approximates component  $i$  of the solution at time  $\text{tspan}(j)$  and mesh points  $\text{xmesh}(:)$ . Use `pdeval` to compute the approximation and its partial derivative  $\partial u_i / \partial x$  at points not included in `xmesh`. See `pdeval` for details.

`sol = pdepe(m, pdefun, icfun, bcfun, xmesh, tspan, options)` solves as above with default integration parameters replaced by values in `options`, an argument created with the `odeset` function. Only some of the options of the underlying ODE solver are available in `pdepe`: `RelTol`, `AbsTol`, `NormControl`, `InitialStep`, and `MaxStep`. The defaults obtained by leaving off the input argument `options` will generally be satisfactory. See `odeset` for details.

`[sol, tsol, sole, te, ie] = pdepe(m, pdefun, icfun, bcfun, xmesh, tspan, options)` with the 'Events' property in `options` set to a function handle `Events`, solves as above while also finding where event functions  $g(t, u(x, t))$  are zero. For each function you specify whether the integration is to terminate at a zero and whether the direction of the zero crossing matters. Three column vectors are returned by `events`: `[value, isterminal, direction] = events(m, t, xmesh, umesh)`. `xmesh` contains the spatial mesh and `umesh` is the solution at the mesh points. Use `pdeval` to evaluate the solution between mesh points. For the  $I$ -th event function, `value(i)` is the value of the function, `ISTERMINAL(I) = 1` if the integration is to terminate at a zero of this event function and 0 otherwise. `direction(i) = 0` if all zeros are to be computed (the default), `+1` if only zeros where the event function is increasing, and `-1` if only zeros where the event function is decreasing. Output `tsol` is a column vector of times specified in `tspan`, prior to first terminal event. `SOL(j, :, :)` is the solution at  $T(j)$ . `TE` is a vector of

times at which events occur. `SOLE(j, :, :)` is the solution at `TE(j)` and indices in vector `IE` specify which event occurred.

If `UI = SOL(j, :, i)` approximates component `i` of the solution at time `TSPAN(j)` and mesh points `XMESH`, `pdeval` evaluates the approximation and its partial derivative  $\partial u_i / \partial x$  at the array of points `XOUT` and returns them in `UOUT` and `DUOUTDX`: `[UOUT, DUOUTDX] = PDEVAL(M, XMESH, UI, XOUT)`

---

**Note** The partial derivative  $\partial u_i / \partial x$  is evaluated here rather than the flux. The flux is continuous, but at a material interface the partial derivative may have a jump.

---

## Tips

- The arrays `xmesh` and `tspan` play different roles in `pdepe`.  
**tspan** – The `pdepe` function performs the time integration with an ODE solver that selects both the time step and formula dynamically. The elements of `tspan` merely specify where you want answers and the cost depends weakly on the length of `tspan`.  
**xmesh** – Second order approximations to the solution are made on the mesh specified in `xmesh`. Generally, it is best to use closely spaced mesh points where the solution changes rapidly. `pdepe` does *not* select the mesh in  $x$  automatically. You must provide an appropriate fixed mesh in `xmesh`. The cost depends strongly on the length of `xmesh`. When  $m > 0$ , it is not necessary to use a fine mesh near  $x = 0$  to account for the coordinate singularity.
- The time integration is done with `ode15s`. `pdepe` exploits the capabilities of `ode15s` for solving the differential-algebraic equations that arise when Equation 1-4 contains elliptic equations, and for handling Jacobians with a specified sparsity pattern.
- After discretization, elliptic equations give rise to algebraic equations. If the elements of the initial conditions vector that correspond to elliptic equations are not "consistent" with the discretization, `pdepe` tries to adjust them before beginning the time integration. For

this reason, the solution returned for the initial time may have a discretization error comparable to that at any other time. If the mesh is sufficiently fine, pdepe can find consistent initial conditions close to the given ones. If pdepe displays a message that it has difficulty finding consistent initial conditions, try refining the mesh.

No adjustment is necessary for elements of the initial conditions vector that correspond to parabolic equations.

## Examples

**Example 1.** This example illustrates the straightforward formulation, computation, and plotting of the solution of a single PDE.

$$\pi^2 \frac{\partial u}{\partial t} = \frac{\partial}{\partial x} \left( \frac{\partial u}{\partial x} \right)$$

This equation holds on an interval  $0 \leq x \leq 1$  for times  $t \geq 0$ .

The PDE satisfies the initial condition

$$u(x, 0) = \sin \pi x$$

and boundary conditions

$$u(0, t) \equiv 0$$

$$\pi e^{-t} + \frac{\partial u}{\partial x}(1, t) = 0$$

It is convenient to use local functions to place all the functions required by pdepe in a single function.

```
function pdex1

m = 0;
x = linspace(0,1,20);
t = linspace(0,2,5);

sol = pdepe(m,@pdex1pde,@pdex1ic,@pdex1bc,x,t);
% Extract the first solution component as u.
```

```
u = sol(:,:,1);

% A surface plot is often a good way to study a solution.
surf(x,t,u)
title('Numerical solution computed with 20 mesh points.')
xlabel('Distance x')
ylabel('Time t')

% A solution profile can also be illuminating.
figure
plot(x,u(end,:))
title('Solution at t = 2')
xlabel('Distance x')
ylabel('u(x,2)')
% -----
function [c,f,s] = pdex1pde(x,t,u,DuDx)
c = pi^2;
f = DuDx;
s = 0;
% -----
function u0 = pdex1ic(x)
u0 = sin(pi*x);
% -----
function [pl,ql,pr,qr] = pdex1bc(xl,ul,xr,ur,t)
pl = ul;
ql = 0;
pr = pi * exp(-t);
qr = 1;
```

In this example, the PDE, initial condition, and boundary conditions are coded in local functions `pdex1pde`, `pdex1ic`, and `pdex1bc`.

The surface plot shows the behavior of the solution.

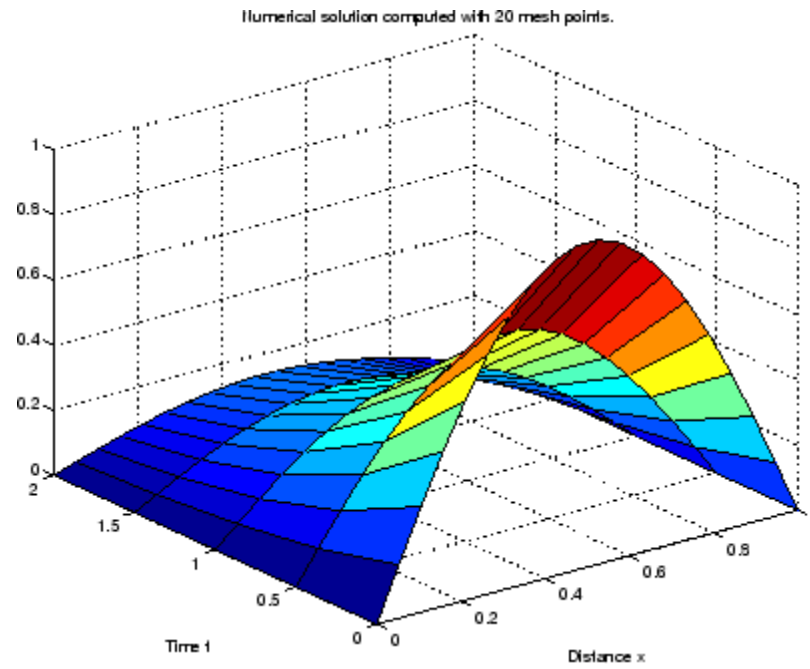

The following plot shows the solution profile at the final value of  $t$  (i.e.,  $t = 2$ ).

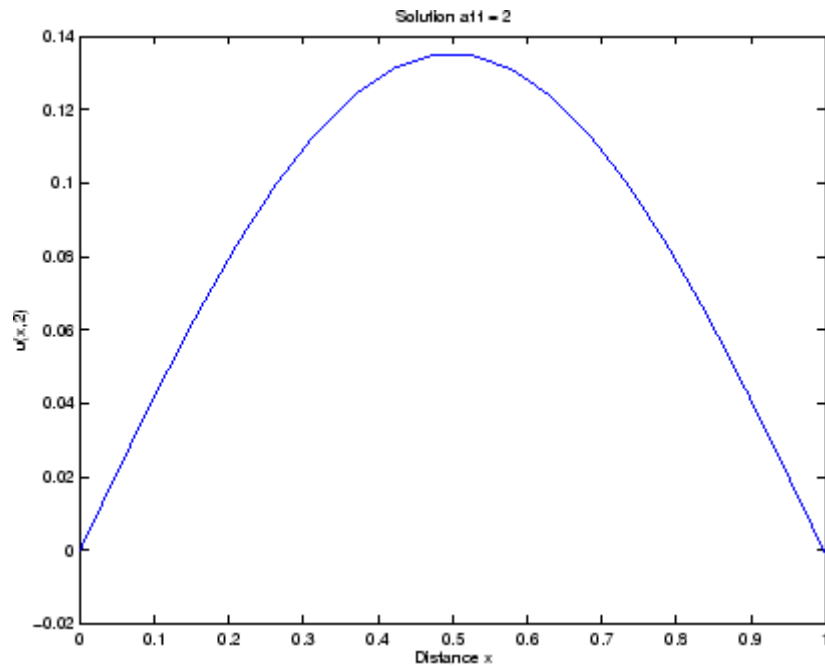

**Example 2.** This example illustrates the solution of a system of PDEs. The problem has boundary layers at both ends of the interval. The solution changes rapidly for small  $t$ .

The PDEs are

$$\frac{\partial u_1}{\partial t} = 0.024 \frac{\partial^2 u_1}{\partial x^2} - F(u_1 - u_2)$$

$$\frac{\partial u_2}{\partial t} = 0.170 \frac{\partial^2 u_2}{\partial x^2} + F(u_1 - u_2)$$

where  $F(y) = \exp(5.73y) - \exp(-11.46y)$ .

This equation holds on an interval  $0 \leq x \leq 1$  for times  $t \geq 0$ .

The PDE satisfies the initial conditions



$$u_1(x, 0) \equiv 1$$

$$u_2(x, 0) \equiv 0$$

and boundary conditions

$$\frac{\partial u_1}{\partial x}(0, t) \equiv 0$$

$$u_2(0, t) \equiv 0$$

$$u_1(1, t) \equiv 1$$

$$\frac{\partial u_2}{\partial x}(1, t) \equiv 0$$

In the form expected by pdepe, the equations are

$$\begin{bmatrix} 1 \\ 1 \end{bmatrix} \cdot * \frac{\partial}{\partial t} \begin{bmatrix} u_1 \\ u_2 \end{bmatrix} = \frac{\partial}{\partial x} \begin{bmatrix} 0.024(\partial u_1 / \partial x) \\ 0.170(\partial u_2 / \partial x) \end{bmatrix} + \begin{bmatrix} -F(u_1 - u_2) \\ F(u_1 - u_2) \end{bmatrix}$$

The boundary conditions on the partial derivatives of  $u$  have to be written in terms of the flux. In the form expected by pdepe, the left boundary condition is

$$\begin{bmatrix} 0 \\ u_2 \end{bmatrix} + \begin{bmatrix} 1 \\ 0 \end{bmatrix} \cdot * \begin{bmatrix} 0.024(\partial u_1 / \partial x) \\ 0.170(\partial u_2 / \partial x) \end{bmatrix} = \begin{bmatrix} 0 \\ 0 \end{bmatrix}$$

and the right boundary condition is

$$\begin{bmatrix} u_1 - 1 \\ 0 \end{bmatrix} + \begin{bmatrix} 0 \\ 1 \end{bmatrix} \cdot * \begin{bmatrix} 0.024(\partial u_1 / \partial x) \\ 0.170(\partial u_2 / \partial x) \end{bmatrix} = \begin{bmatrix} 0 \\ 0 \end{bmatrix}$$

The solution changes rapidly for small  $t$ . The program selects the step size in time to resolve this sharp change, but to see this behavior in the plots, the example must select the output times accordingly. There are boundary layers in the solution at both ends of  $[0, 1]$ , so the example places mesh points near 0 and 1 to resolve these sharp changes. Often

some experimentation is needed to select a mesh that reveals the behavior of the solution.

```
function pdex4
m = 0;
x = [0 0.005 0.01 0.05 0.1 0.2 0.5 0.7 0.9 0.95 0.99 0.995 1];
t = [0 0.005 0.01 0.05 0.1 0.5 1 1.5 2];

sol = pdepe(m,@pdex4pde,@pdex4ic,@pdex4bc,x,t);
u1 = sol(:,:,1);
u2 = sol(:,:,2);

figure
surf(x,t,u1)
title('u1(x,t)')
xlabel('Distance x')
ylabel('Time t')

figure
surf(x,t,u2)
title('u2(x,t)')
xlabel('Distance x')
ylabel('Time t')
% -----
function [c,f,s] = pdex4pde(x,t,u,DuDx)
c = [1; 1];
f = [0.024; 0.17] .* DuDx;
y = u(1) - u(2);
F = exp(5.73*y) - exp(-11.47*y);
s = [-F; F];
% -----
function u0 = pdex4ic(x);
u0 = [1; 0];
% -----
function [pl,ql,pr,qr] = pdex4bc(xl,ul,xr,ur,t)
pl = [0; ul(2)];
ql = [1; 0];
```

```
pr = [ur(1)-1; 0];
qr = [0; 1];
```

In this example, the PDEs, initial conditions, and boundary conditions are coded in local functions `pdex4pde`, `pdex4ic`, and `pdex4bc`.

The surface plots show the behavior of the solution components.

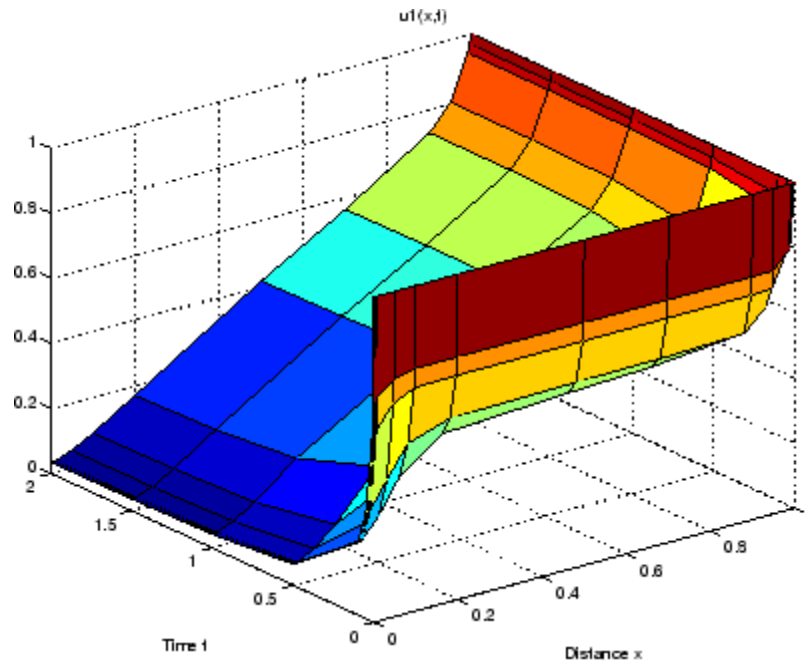

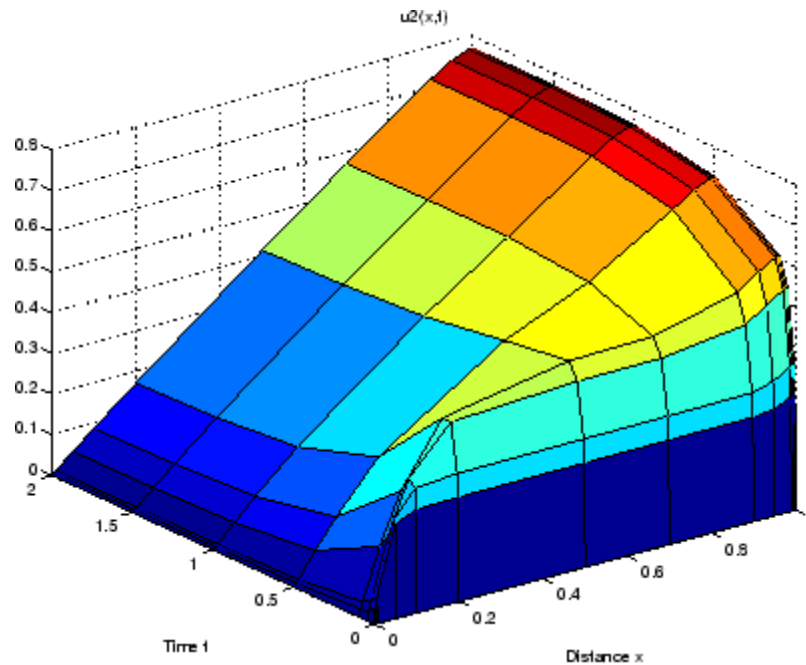

## References

[1] Skeel, R. D. and M. Berzins, "A Method for the Spatial Discretization of Parabolic Equations in One Space Variable," *SIAM Journal on Scientific and Statistical Computing*, Vol. 11, 1990, pp.1–32.

## See Also

`function_handle` | `pdeval` | `ode15s` | `odeset` | `odeget`

**Purpose** Evaluate numerical solution of PDE using output of pdepe

**Syntax** `[uout,duoutdx] = pdeval(m,x,ui,xout)`

### Arguments

m	Symmetry of the problem: slab = 0, cylindrical = 1, spherical = 2. This is the first input argument used in the call to pdepe.
xmesh	A vector <code>[x0, x1, ..., xn]</code> specifying the points at which the elements of <code>ui</code> were computed. This is the same vector with which pdepe was called.
ui	A vector <code>sol(j,:,i)</code> that approximates component <code>i</code> of the solution at time $t_j$ and mesh points <code>xmesh</code> , where <code>sol</code> is the solution returned by pdepe.
xout	A vector of points from the interval <code>[x0,xn]</code> at which the interpolated solution is requested.

### Description

`[uout,duoutdx] = pdeval(m,x,ui,xout)` approximates the solution  $u_i$  and its partial derivative  $\partial u_i / \partial x$  at points from the interval `[x0,xn]`. The pdeval function returns the computed values in `uout` and `duoutdx`, respectively.

---

**Note** pdeval evaluates the partial derivative  $\partial u_i / \partial x$  rather than the flux  $f$ . Although the flux is continuous, the partial derivative may have a jump at a material interface.

---

### See Also

pdepe

# peaks

---

## Purpose

Example function of two variables

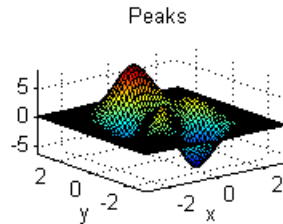

## Syntax

```
Z = peaks;
Z = peaks(n);
Z = peaks(V);
Z = peaks(X,Y);
peaks(...)
[X,Y,Z] = peaks(...);
```

## Description

`peaks` is a function of two variables, obtained by translating and scaling Gaussian distributions, which is useful for demonstrating `mesh`, `surf`, `pcolor`, `contour`, and so on.

`Z = peaks`; returns a 49-by-49 matrix.

`Z = peaks(n)`; returns an n-by-n matrix.

`Z = peaks(V)`; returns an n-by-n matrix, where `n = length(V)`.

`Z = peaks(X,Y)`; evaluates `peaks` at the given `X` and `Y` (which must be the same size) and returns a matrix the same size.

`peaks(...)` (with no output argument) plots the `peaks` function with `surf`. Use any of the input argument combinations in the previous syntaxes.

`[X,Y,Z] = peaks(...)`; returns two additional matrices, `X` and `Y`, for parametric plots, for example, `surf(X,Y,Z,de12(Z))`. If not given as input, the underlying matrices `X` and `Y` are

```
[X,Y] = meshgrid(V,V)
```

where  $V$  is a given vector, or  $V$  is a vector of length  $n$  with elements equally spaced from  $-3$  to  $3$ . If no input argument is given, the default  $n$  is 49.

## Examples

This example creates a 5-by-5 matrix of peaks and displays the image:

```
peaks(5);
```

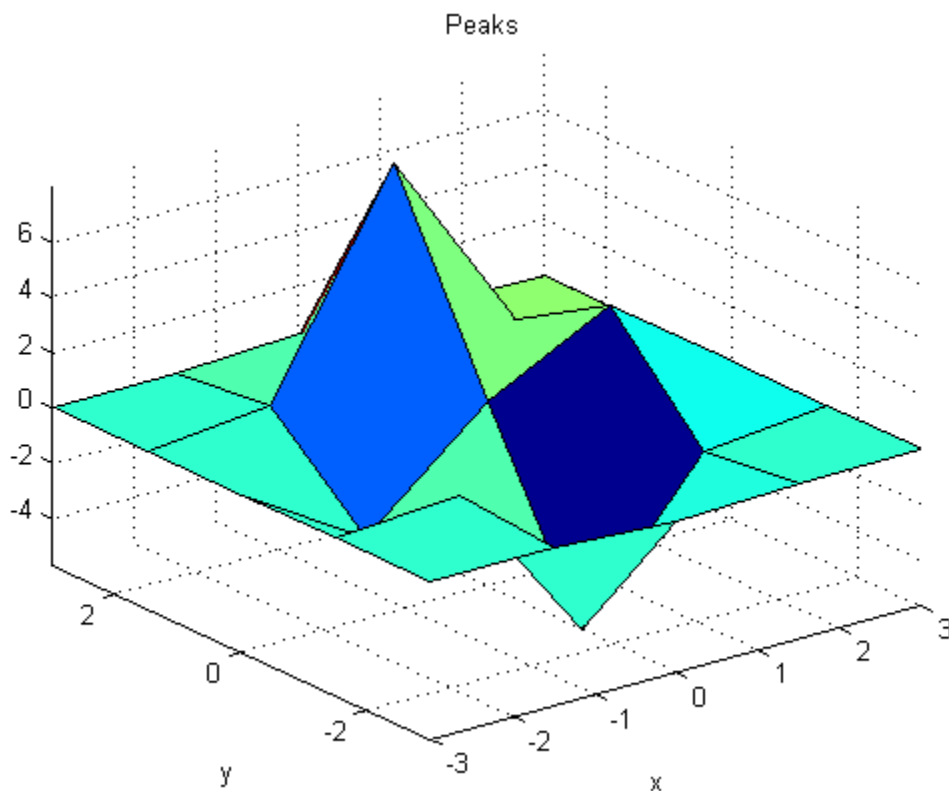

See Examples section from `surf` for a more elaborate use case.

# peaks

---

## See Also

[meshgrid](#) | [surf](#)



**Purpose**

Call Perl script using appropriate operating system executable

**Syntax**

```
perl('perlfile')
perl('perlfile',arg1,arg2,...)
result = perl(...)
[result, status] = perl(...)
```

**Description**

`perl('perlfile')` calls the Perl script `perlfile`, using the appropriate operating system Perl executable. Perl is included with the MATLAB software on Microsoft Windows systems, and thus MATLAB users can run user-created MATLAB functions containing the `perl` function. On Linux and Macintosh systems, MATLAB calls the Perl interpreter available with the operating system.

`perl('perlfile',arg1,arg2,...)` calls the Perl script `perlfile`, using the appropriate operating system Perl executable, and passes the arguments `arg1`, `arg2`, and so on, to `perlfile`.

`result = perl(...)` returns the results of attempted Perl call to `result`.

`[result, status] = perl(...)` returns the results of attempted Perl call to `result` and its exit status to `status`.

It is sometimes beneficial to use Perl scripts instead of MATLAB code. The `perl` function allows you to run those scripts from MATLAB. Specific examples where you might choose to use a Perl script include:

- Perl script already exists
- Perl script preprocesses data quickly, formatting it in a way more easily read by MATLAB
- Perl has features not supported by MATLAB

**Examples**

Given the Perl script, `hello.pl`:

```
$input = $ARGV[0];
print "Hello $input.";
```

# perl

---

At the MATLAB command line, type:

```
perl('hello.pl','World')
```

```
ans =
Hello World.
```

## **See Also**

`dos` | `regexp` | `system` | `unix` | `!` (exclamation point)

<b>Purpose</b>	All possible permutations
<b>Syntax</b>	<code>P = perms(v)</code>
<b>Description</b>	<code>P = perms(v)</code> returns a matrix containing all permutations of the elements of vector <code>v</code> in reverse lexicographic order. Each row of <code>P</code> contains a different permutation of the $n$ elements in <code>v</code> . Matrix <code>P</code> has the same data type as <code>v</code> , and it has $n!$ rows and $n$ columns.
<b>Input Arguments</b>	<p><b>v - Set of items</b> vector of numeric, logical, or char values</p> <p>Set of items, specified as a vector of numeric, logical, or char values.</p> <p><b>Example:</b> <code>[1 2 3 4]</code></p> <p><b>Example:</b> <code>[1+1i 2+1i 3+1i 4+1i]</code></p> <p><b>Example:</b> <code>int16([1 2 3 4])</code></p> <p><b>Example:</b> <code>['abcd']</code></p> <p><b>Example:</b> <code>[true false true false]</code></p> <p><b>Data Types</b> single   double   int8   int16   int32   int64   uint8   uint16   uint32   uint64   logical   char</p> <p><b>Complex Number Support:</b> Yes</p>
<b>Limitations</b>	<code>perms(v)</code> is practical when <code>length(v)</code> is less than about 10.
<b>Examples</b>	<p><b>All Permutations of Double Integers</b></p> <pre>v = [2 4 6]; P = perms(v)  P =       6     4     2      6     2     4</pre>

```
4 6 2
4 2 6
2 4 6
2 6 4
```

## All Permutations of Unsigned Integers

```
v = uint16([1023 4095 65535]);
P = perms(v)
```

P =

```
65535 4095 1023
65535 1023 4095
 4095 65535 1023
 4095 1023 65535
1023 4095 65535
1023 65535 4095
```

## All Permutations of Complex Numbers

```
v = [1+1i 2+1i 3+1i];
P = perms(v)
```

P =

```
3.0000 + 1.0000i 2.0000 + 1.0000i 1.0000 + 1.0000i
3.0000 + 1.0000i 1.0000 + 1.0000i 2.0000 + 1.0000i
2.0000 + 1.0000i 3.0000 + 1.0000i 1.0000 + 1.0000i
2.0000 + 1.0000i 1.0000 + 1.0000i 3.0000 + 1.0000i
1.0000 + 1.0000i 2.0000 + 1.0000i 3.0000 + 1.0000i
1.0000 + 1.0000i 3.0000 + 1.0000i 2.0000 + 1.0000i
```

## See Also

[nchoosek](#) | [permute](#) | [randperm](#)

**Purpose** Rearrange dimensions of N-D array

**Syntax** `B = permute(A,order)`

**Description** `B = permute(A,order)` rearranges the dimensions of `A` so that they are in the order specified by the vector `order`. `B` has the same values of `A` but the order of the subscripts needed to access any particular element is rearranged as specified by `order`. All the elements of `order` must be unique, real, positive, integer values.

**Tips** `permute` and `ipermute` are a generalization of transpose (`.'`) for multidimensional arrays.

**Examples** Given any matrix `A`, the statement

```
permute(A,[2 1])
```

is the same as `A.'`

For example:

```
A = [1 2; 3 4]; permute(A,[2 1])
ans =
 1 3
 2 4
```

The following code permutes a three-dimensional array:

```
X = rand(12,13,14);
Y = permute(X,[2 3 1]);
size(Y)
ans =
 13 14 12
```

**See Also** `ipermute` | `circshift` | `flip1r` | `flipud` | `reshape` | `shiftdim`

# persistent

---

**Purpose** Define persistent variable

**Syntax** `persistent X Y Z`

**Description** `persistent X Y Z` defines X, Y, and Z as variables that are local to the function in which they are declared; yet their values are retained in memory between calls to the function. Persistent variables are similar to global variables because the MATLAB software creates permanent storage for both. They differ from global variables in that persistent variables are known only to the function in which they are declared. This prevents persistent variables from being changed by other functions or from the MATLAB command line.

Whenever you clear or modify a function that is in memory, MATLAB also clears all persistent variables declared by that function. To keep a function in memory until MATLAB quits, use `mlock`.

If the persistent variable does not exist the first time you issue the `persistent` statement, it is initialized to the empty matrix.

It is an error to declare a variable persistent if a variable with the same name exists in the current workspace. MATLAB also errors if you declare any of a function's input or output arguments as persistent within that same function. For example, the following persistent declaration is invalid:

```
function myfun(argA, argB, argC)
persistent argB
```

**Tips** There is no function form of the `persistent` command (i.e., you cannot use parentheses and quote the variable names).

**Examples** This function writes a large array to a spreadsheet file and then reads several rows from the same file. Because you only need to write the array to the spreadsheet one time, the program tests whether an array can be read from the file and, if so, does not waste time in repeating that task. By defining the `dblArray` variable as persistent, you can easily check whether the array has been read from the spreadsheet file.

Here is the arrayToXLS function:

```
function arrayToXLS(A, xlsfile, x1, x2)
persistent dblArray;

if isempty(dblArray)
 disp 'Writing spreadsheet file ...'
 xlswrite(xlsfile, A);
end

disp 'Reading array from spreadsheet ...'
dblArray = xlsread(xlsfile, 'Sheet1', [x1 ':' x2])
fprintf('\n');
```

Run the function three times and observe the time elapsed for each run. The second and third run take approximately one tenth the time of the first run in which the function must create the spreadsheet:

```
largeArray = rand(4000, 200);

tic, arrayToXLS(largeArray, 'myTest.xls','E254', 'J256'), toc
Writing spreadsheet file ...
Reading array from spreadsheet ...
dblArray =
 0.0982 0.3783 0.1264 0.7880 0.1902 0.5811
 0.2251 0.2704 0.5682 0.7271 0.8028 0.2834
 0.6453 0.5568 0.8254 0.4961 0.9096 0.5402
```

Elapsed time is 8.990525 seconds.

```
tic, arrayToXLS(largeArray, 'myTest.xls','E257', 'J258'), toc
Reading array from spreadsheet ...
dblArray =
 0.4620 0.3781 0.6386 0.5930 0.0946 0.4865
 0.1605 0.1251 0.8709 0.5188 0.6702 0.2138
```

Elapsed time is 0.912534 seconds.

```
tic, arrayToXLS(largeArray, 'myTest.xls','E259', 'J262'), toc
Reading array from spreadsheet ...
dblArray =
 0.7015 0.6588 0.4023 0.0359 0.4512 0.6097
 0.1308 0.6441 0.0431 0.6396 0.7481 0.8688
 0.8278 0.2686 0.5475 0.8550 0.5896 0.1080
 0.9437 0.1671 0.0505 0.1203 0.2461 0.7306
```

Elapsed time is 0.928843 seconds.

Now clear the arrayToXLS function from memory and observe that running it takes much longer again:

```
clear functions
```

```
tic, arrayToXLS(largeArray, 'myTest.xls','E263', 'J264'), toc
Writing spreadsheet file ...
Reading array from spreadsheet ...
dblArray =
 0.6292 0.7788 0.0732 0.6481 0.9299 0.8631
 0.7700 0.5181 0.9805 0.5092 0.8658 0.4070
```

Elapsed time is 7.603461 seconds.

## See Also

[global](#) | [clear](#) | [mislocked](#) | [mlock](#) | [munlock](#) | [isempty](#)



**Purpose** Ratio of circle's circumference to its diameter

**Syntax** pi

**Description** pi returns the floating-point number nearest the value of  $\pi$ . The expressions `4*atan(1)` and `imag(log(-1))` provide the same value.

**Examples** Find the sine of  $\pi$ :

```
sin(pi)
```

```
returns
```

```
ans =
```

```
1.2246e-16
```

The expression `sin(pi)` is not exactly zero because `pi` is not exactly  $\pi$ .

# pie

---

## Purpose

Pie chart



## Syntax

```
pie(X)
pie(X,explode)
pie(...,labels)
pie(axes_handle,...)
h = pie(...)
```

## Description

`pie(X)` draws a pie chart using the data in `X`. Each element in `X` is represented as a slice in the pie chart.

- If  $\text{sum}(X) = 1$ , then the values in `X` directly specify the area of the pie slices. `pie` draws only a partial pie if  $\text{sum}(X) < 1$ .
- If the sum of the elements in `X` is greater than one, then `pie` normalizes the values by  $X/\text{sum}(X)$  to determine the area of each slice of the pie.

`pie(X,explode)` offsets a slice from the pie. `explode` is a vector or matrix of zeros and nonzeros that correspond to `X`. A nonzero value offsets the corresponding slice from the center of the pie chart, so that `X(i,j)` is offset from the center if `explode(i,j)` is nonzero. `explode` must be the same size as `X`.

`pie(...,labels)` specifies text labels for the slices. The number of labels must equal the number of elements in `X`.

`pie(axes_handle,...)` plots into the axes with the handle `axes_handle` instead of into the current axes (`gca`).

`h = pie(...)` returns a vector of handles to patch and text graphics objects.

## Examples

### Create Pie Chart

Create a pie chart of vector `x`.

```
x = [1,3,0.5,2.5,2];
figure
pie(x)
```

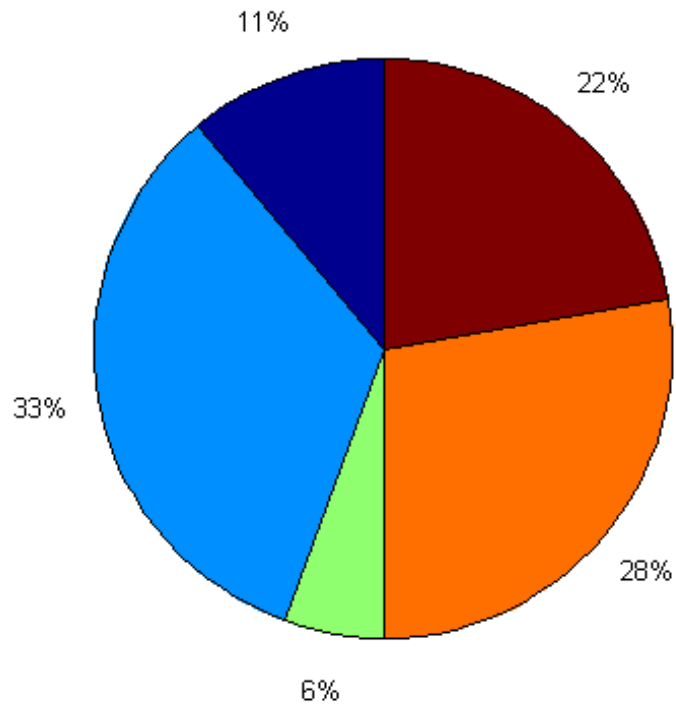

To offset the second and fourth pie slices, set the corresponding explode elements to 1.

```
explode = [0,1,0,1,0];
figure
pie(x,explode)
```

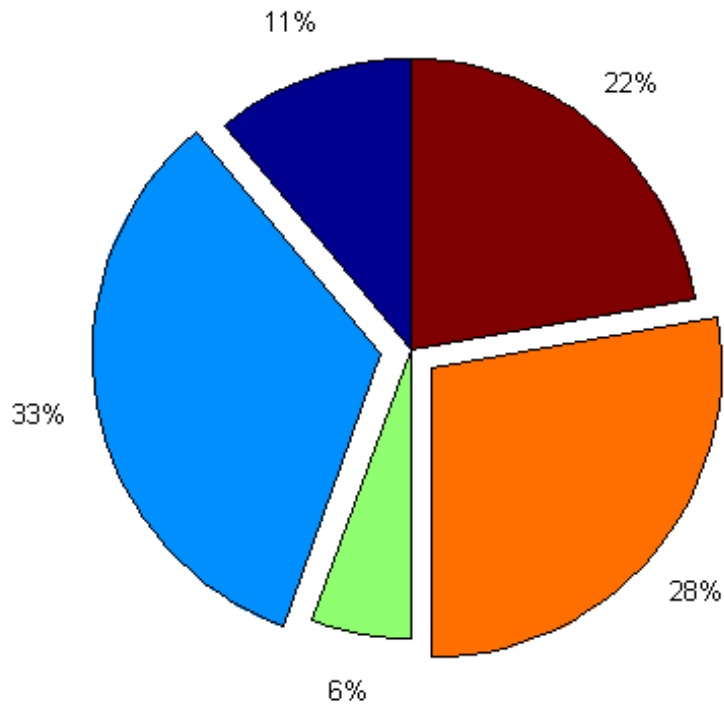

### Specify Text Labels for Pie Chart

Specify the text labels for a pie chart.

```
x = 1:3;
labels = {'Taxes', 'Expenses', 'Profit'};
```

```
figure
pie(x, labels)
```

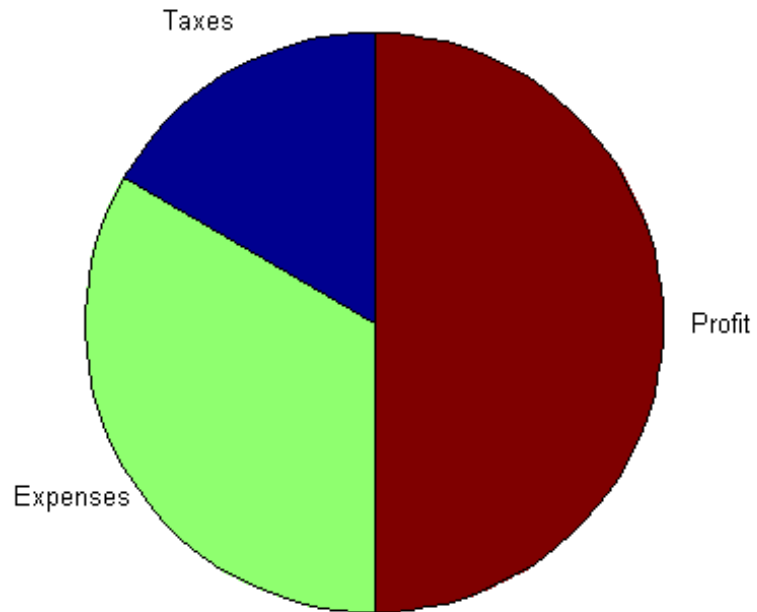

### Remove Piece From Pie Chart

Create a pie chart of `x`.

```
x = [0.19,0.22,0.41];
figure
pie(x)
```

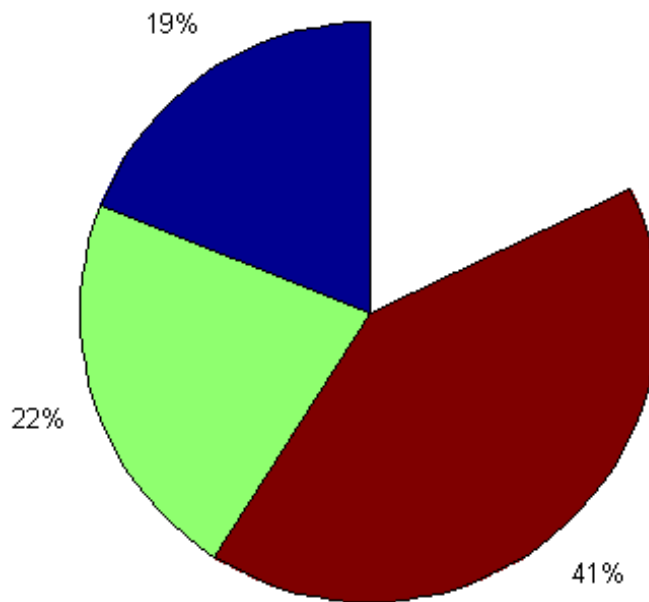

Since the sum of the elements in `x` is less than 1, `pie` draws a partial pie.

## See Also

`pie3`

## How To

- “Offset Pie Slice with Greatest Contribution”
- “Label Pie Chart With Text and Percent Values”

**Purpose**

3-D pie chart

**Syntax**

```
pie3(X)
pie3(X,explode)
pie3(...,labels)
pie3(axes_handle,...)
h = pie3(...)
```

**Description**

`pie3(X)` draws a three-dimensional pie chart using the data in `X`. Each element in `X` is represented as a slice in the pie chart.

- If  $\text{sum}(X) = 1$ , then the values in `X` directly specify the area of the pie slices. `pie3` draws only a partial pie if  $\text{sum}(X) < 1$ .
- If the sum of the elements in `X` is greater than one, then `pie3` normalizes the values by  $X/\text{sum}(X)$  to determine the area of each slice of the pie.

`pie3(X,explode)` specifies whether to offset a slice from the center of the pie chart. `X(i,j)` is offset from the center of the pie chart if `explode(i,j)` is nonzero. `explode` must be the same size as `X`.

`pie3(...,labels)` specifies text labels for the slices. The number of labels must equal the number of elements in `X`.

`pie3(axes_handle,...)` plots into the axes with the handle `axes_handle` instead of into the current axes (`gca`).

`h = pie3(...)` returns a vector of handles to patch, surface, and text graphics objects.

**Examples****Create 3-D Pie Chart**

Create a 3-D pie chart of vector `x`.

```
x = [1,3,0.5,2.5,2];
```

# pie3

---

```
figure
pie3(x);
```

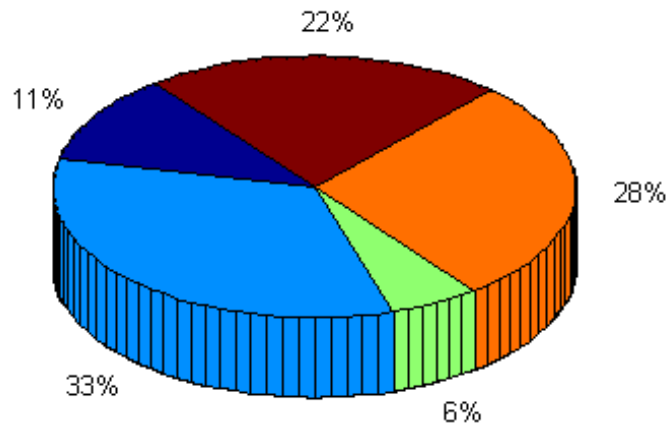

To offset the second pie slice, set the corresponding `explode` element to 1.

```
explode = [0,1,0,0,0];
figure
pie3(x,explode)
```



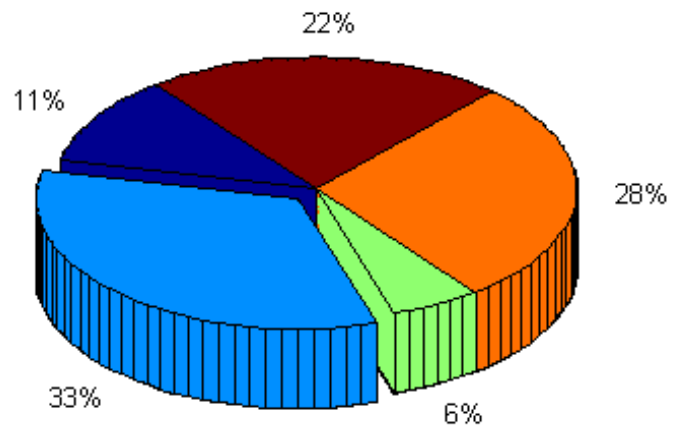

### Specify Text Labels for 3-D Pie Chart

Create a 3-D pie chart and specify the text labels.

```
x = 1:3;
labels = {'Taxes', 'Expenses', 'Profit'};
```

```
figure
pie3(x, labels)
```

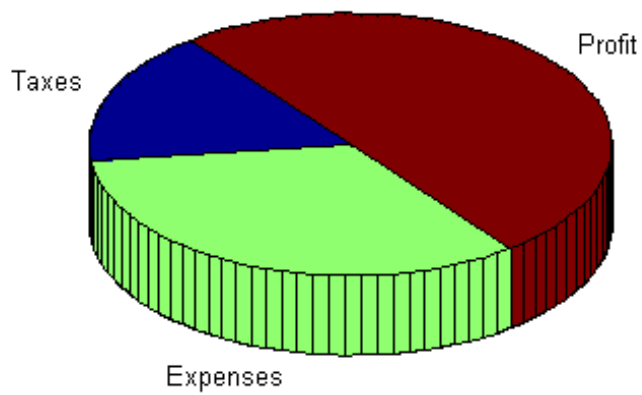

**See Also** [pie](#)

<b>Purpose</b>	Moore-Penrose pseudoinverse of matrix
<b>Syntax</b>	$B = \text{pinv}(A)$ $B = \text{pinv}(A, \text{tol})$
<b>Definitions</b>	<p>The Moore-Penrose pseudoinverse is a matrix <math>B</math> of the same dimensions as <math>A'</math> satisfying four conditions:</p> $A*B*A = A$ $B*A*B = B$ $A*B \text{ is Hermitian}$ $B*A \text{ is Hermitian}$ <p>The computation is based on <math>\text{svd}(A)</math> and any singular values less than <math>\text{tol}</math> are treated as zero.</p>
<b>Description</b>	<p><math>B = \text{pinv}(A)</math> returns the Moore-Penrose pseudoinverse of <math>A</math>.</p> <p><math>B = \text{pinv}(A, \text{tol})</math> returns the Moore-Penrose pseudoinverse and overrides the default tolerance, <math>\max(\text{size}(A)) * \text{norm}(A) * \text{eps}</math>.</p>
<b>Examples</b>	<p>If <math>A</math> is square and not singular, then <math>\text{pinv}(A)</math> is an expensive way to compute <math>\text{inv}(A)</math>. If <math>A</math> is not square, or is square and singular, then <math>\text{inv}(A)</math> does not exist. In these cases, <math>\text{pinv}(A)</math> has some of, but not all, the properties of <math>\text{inv}(A)</math>.</p> <p>If <math>A</math> has more rows than columns and is not of full rank, then the overdetermined least squares problem</p> $\text{minimize } \text{norm}(A*x-b)$ <p>does not have a unique solution. Two of the infinitely many solutions are</p> $x = \text{pinv}(A)*b$ <p>and</p> $y = A \setminus b$

These two are distinguished by the facts that  $\text{norm}(x)$  is smaller than the norm of any other solution and that  $y$  has the fewest possible nonzero components.

For example, the matrix generated by

```
A = magic(8); A = A(:,1:6)
```

is an 8-by-6 matrix that happens to have  $\text{rank}(A) = 3$ .

```
A =
 64 2 3 61 60 6
 9 55 54 12 13 51
 17 47 46 20 21 43
 40 26 27 37 36 30
 32 34 35 29 28 38
 41 23 22 44 45 19
 49 15 14 52 53 11
 8 58 59 5 4 62
```

The right-hand side is  $b = 260 \cdot \text{ones}(8, 1)$ ,

```
b =
 260
 260
 260
 260
 260
 260
 260
 260
 260
```

The scale factor 260 is the 8-by-8 magic sum. With all eight columns, one solution to  $A \cdot x = b$  would be a vector of all 1's. With only six columns, the equations are still consistent, so a solution exists, but it is not all 1's. Since the matrix is rank deficient, there are infinitely many solutions. Two of them are

```
x = pinv(A)*b
```

which is

```
x =
 1.1538
 1.4615
 1.3846
 1.3846
 1.4615
 1.1538
```

and

```
y = A\b
```

which produces this result.

```
Warning: Rank deficient, rank = 3 tol = 1.8829e-013.
```

```
y =
 4.0000
 5.0000
 0
 0
 0
 -1.0000
```

Both of these are exact solutions in the sense that  $\text{norm}(A*x-b)$  and  $\text{norm}(A*y-b)$  are on the order of roundoff error. The solution  $x$  is special because

```
norm(x) = 3.2817
```

is smaller than the norm of any other solution, including

```
norm(y) = 6.4807
```

On the other hand, the solution  $y$  is special because it has only three nonzero components.

## See Also

[inv](#) | [qr](#) | [rank](#) | [svd](#)

# planerot

---

**Purpose** Givens plane rotation

**Syntax** `[G,y] = planerot(x)`

**Description** `[G,y] = planerot(x)` where  $x$  is a 2-component column vector, returns a 2-by-2 orthogonal matrix  $G$  so that  $y = G*x$  has  $y(2) = 0$ .

**Examples**

```
x = [3 4];
[G,y] = planerot(x')
```

```
G =
 0.6000 0.8000
 -0.8000 0.6000
```

```
y =
 5
 0
```

**See Also** `qrdelete` | `qrinsert`

**Purpose**

Play audio from audioplayer object

**Syntax**

```
play(playerObj)
play(playerObj, start)
play(playerObj, [start, stop])
```

**Description**

`play(playerObj)` plays the audio associated with audioplayer object `playerObj` from beginning to end.

`play(playerObj, start)` plays audio from the sample indicated by `start` to the end.

`play(playerObj, [start, stop])` plays audio from the sample indicated by `start` to the sample indicated by `stop`.

**Examples****Play with and without Blocking**

Play two audio samples with and without blocking using the `play` and `playblocking` methods.

Load data from example files `chirp.mat` and `gong.mat`.

```
chirpData = load('chirp.mat');
chirpObj = audioplayer(chirpData.y, chirpData.Fs);
```

```
gongData = load('gong.mat');
gongObj = audioplayer(gongData.y, gongData.Fs);
```

Play the samples with blocking, one after the other.

```
playblocking(chirpObj);
playblocking(gongObj);
```

Play without blocking. The audio can overlap.

```
play(chirpObj);
play(gongObj);
```

# audioplayer.play

---

## Starting Sample

Play audio from the example file `handel.mat` starting 4 seconds from the beginning.

```
load handel.mat;
playerObj = audioplayer(y,Fs);
start = playerObj.SampleRate * 4;

play(playerObj,start);
```

## Sample Range

Play the first 3 seconds of audio from the example file `handel.mat`.

```
load handel.mat;
playerObj = audioplayer(y,Fs);
start = 1;
stop = playerObj.SampleRate * 3;

play(playerObj,[start,stop]);
```

## See Also

[audioplayer](#) | [playblocking](#)

## How To

- “Play Audio”



**Purpose** Play audio from audiorecorder object

**Syntax**

```
player = play(recObj)
player = play(recObj, start)
player = play(recObj, [start stop])
```

**Description**

*player* = play(*recObj*) plays the audio associated with audiorecorder object *recObj* from beginning to end, and returns an audioplayer object.

*player* = play(*recObj*, *start*) plays audio from the sample indicated by *start* to the end.

*player* = play(*recObj*, [*start stop*]) plays audio from the sample indicated by *start* to the sample indicated by *stop*.

**Examples** Record 5 seconds of your speech with a microphone, and play it back. Display the properties of the audioplayer object.

```
myVoice = audiorecorder;

disp('Start speaking. ');
recordblocking(myVoice, 5);
disp('End of recording. Playing back ...');

playerObj = play(myVoice);

disp('Properties of playerObj:');
get(playerObj)
```

---

Play back only the first 3 seconds of the speech recorded in the previous example:

```
play(myVoice, [1 myVoice.SampleRate*3]);
```

**See Also** audioplayer | audiorecorder

# audioplayer.playblocking

---

**Purpose** Play audio from audioplayer object, holding control until playback completes

**Syntax**

```
playblocking(playerObj)
playblocking(playerObj,start)
playblocking(playerObj,[start,stop])
```

**Description**

playblocking(playerObj) plays the audio associated with audioplayer object playerObj from beginning to end. playblocking does not return control until playback completes.

playblocking(playerObj,start) plays audio from the sample indicated by start to the end.

playblocking(playerObj,[start,stop]) plays audio from the sample indicated by start to the sample indicated by stop.

## **Examples**      **Play with and without Blocking**

Play two audio samples with and without blocking using the play and playblocking methods.

Load data from example files chirp.mat and gong.mat.

```
chirpData = load('chirp.mat');
chirpObj = audioplayer(chirpData.y,chirpData.Fs);
```

```
gongData = load('gong.mat');
gongObj = audioplayer(gongData.y,gongData.Fs);
```

Play the samples with blocking, one after the other.

```
playblocking(chirpObj);
playblocking(gongObj);
```

Play without blocking. The audio can overlap.

```
play(chirpObj);
play(gongObj);
```

## Starting Sample

Play audio from the example file `handel.mat` starting 4 seconds from the beginning.

```
load handel.mat;
playerObj = audioplayer(y,Fs);
start = playerObj.SampleRate * 4;

playblocking(playerObj,start);
beep;
```

## Sample Range

Play the first 3 seconds of audio from the example file `handel.mat`.

```
load handel.mat;
playerObj = audioplayer(y,Fs);
start = 1;
stop = playerObj.SampleRate * 3;

playblocking(playerObj,[start,stop]);
beep;
```

## See Also

[audioplayer](#) | [play](#)

## How To

- “Play Audio”

# plot

---

**Purpose** 2-D line plot

**Syntax**

```
plot(X,Y)
plot(X,Y,LineStyle)
plot(X1,Y1,...,Xn,Yn)
plot(X1,Y1,LineStyle1,...,Xn,Yn,LineStylen)

plot(Y)
plot(Y,LineStyle)

plot(__,Name,Value)
plot(axes_handle, __)

h = plot(__)
```

**Description** `plot(X,Y)` creates a 2-D line plot of the data in `Y` versus the corresponding values in `X`.

- If `X` and `Y` are both vectors, then they must have equal length and MATLAB plots `Y` versus `X`.
- If `X` and `Y` are both matrices, then they must have equal size and MATLAB plots columns of `Y` versus columns of `X`.
- If one of `X` or `Y` is a vector and the other is a matrix, then the matrix must have dimensions such that one of its dimensions equals the vector length. If the number of matrix rows equals the vector length, then MATLAB plots each matrix column versus the vector. If the number of matrix columns equals the vector length, then MATLAB plots each matrix row versus the vector. If the matrix is square, then MATLAB plots each column versus the vector.
- If one of `X` or `Y` is a scalar and the other is a vector, then MATLAB plots the vector as discrete points at the scalar value.

`plot(X,Y,LineStyle)` sets the line style, marker symbol, and color.

`plot(X1,Y1,...,Xn,Yn)` plots multiple X, Y pairs using the same axes for all lines.

`plot(X1,Y1,LineStyle1,...,Xn,Yn,LineStylen)` sets the line style, marker type, and color for each line. You can mix X, Y, LineSpec triplets with X, Y pairs. For example, `plot(X1,Y1,X2,Y2,LineStyle2,X3,Y3)`.

`plot(Y)` creates a 2-D line plot of the data in Y versus the index of each value.

- If Y is a vector, then the x-axis scale ranges from 1 to `length(Y)`.
- If Y is a matrix, then MATLAB plots the columns of Y versus their row number. The x-axis scale ranges from 1 to the number of rows in Y.
- If Y is complex, then MATLAB plots the imaginary part of Y versus the real part of Y, such that `plot(Y)` is equivalent to `plot(real(Y),imag(Y))`.

`plot(Y,LineStyle)` sets the line style, marker symbol, and color.

`plot(___,Name,Value)` specifies lineseries properties using one or more Name, Value pair arguments. Use this option with any of the input argument combinations in the previous syntaxes. Name, Value pair settings apply to all the lines plotted. You cannot specify different Name, Value pairs for each line using this syntax.

`plot(axes_handle, ___)` plots into the axes specified by `axes_handle` instead of into the current axes (`gca`). The option, `axes_handle` can precede any of the input combinations in the previous syntaxes.

`h = plot(___)` returns a column vector of lineseries handles, where h contains one handle per line plotted. When multiple lines are present, you can make changes to properties of a specific line by specifying its handle.

# plot

---

## Input Arguments

### Y - Data values to plot

scalar | vector | matrix

Data values to plot, specified as a scalar, a vector, or a matrix. To plot against specific  $x$ -values you must also specify X.

#### Data Types

single | double | int8 | int16 | int32 | int64 | uint8 | uint16 | uint32 | uint64 | logical

**Complex Number Support:** Yes

### X - Locations along the x-axis to plot data values in Y

scalar | vector | matrix

Locations along the  $x$ -axis to plot data values in Y, specified as a scalar, a vector, or a matrix. If you specify both X and Y input arguments, and if either X or Y is complex, then plot ignores the imaginary components.

#### Data Types

single | double | int8 | int16 | int32 | int64 | uint8 | uint16 | uint32 | uint64 | logical

### LineStyle - Line style, marker symbol, and color

string

Line style, marker symbol, and color, specified as a string. The elements of the string can appear in any order, and you can omit one or more options from the string specifier. If you omit the line style and specify the marker character, then the plot shows only the marker and no line.

If Y is a matrix and you specify a color with LineSpec, then all lines are plotted using the specified color. If you specify a marker type or line style and do not specify a color, then MATLAB cycles through the predefined color order.

**Example:** '- -or' is a red dashed line with circle markers

Specifier	Line Style
-	Solid line (default)
--	Dashed line
:	Dotted line
-.	Dash-dot line

Specifier	Marker
o	Circle
+	Plus sign
*	Asterisk
.	Point
x	Cross
s	Square
d	Diamond
^	Upward-pointing triangle
v	Downward-pointing triangle
>	Right-pointing triangle
<	Left-pointing triangle
p	Pentagram
h	Hexagram

Specifier	Color
y	yellow
m	magenta
c	cyan

Specifier	Color
r	red
g	green
b	blue
w	white
k	black

## **axes\_handle - Axes handle**

handle

Axes handle, which is the reference to an axes object. Use the `gca` function to get the handle to the current axes, for example, `axes_handle = gca;`

## **Name-Value Pair Arguments**

Specify optional comma-separated pairs of **Name**, **Value** arguments. **Name** is the argument name and **Value** is the corresponding value. **Name** must appear inside single quotes ( ' '). You can specify several name and value pair arguments in any order as `Name1,Value1,...,NameN,ValueN`.

For a complete list of lineseries properties, see `lineseries` properties.

**Example:** `'Marker','o','MarkerFaceColor','red'`

## **'Color' - Color**

[0 0 1] (blue) (default) | three-element RGB vector | string

Color, specified as the comma-separated pair consisting of 'Color' and a three-element RGB vector or a string containing the short or long name of the color. The RGB vector is a three-element row vector whose elements specify the intensities of the red, green, and blue components of the color. The intensities must be in the range [0 1].

This table lists the predefined colors and their RGB equivalents.



RGB Vector	Short Name	Long Name
[1 1 0]	'y'	'yellow'
[1 0 1]	'm'	'magenta'
[0 1 1]	'c'	'cyan'
[1 0 0]	'r'	'red'
[0 1 0]	'g'	'green'
[0 0 1]	'b'	'blue'
[1 1 1]	'w'	'white'
[0 0 0]	'k'	'black'

Example: 'Color',[0 1 0]

Example: 'Color','green'

Example: 'Color','g'

### 'LineStyle' - Line style

'-' (default) | '--' | ':' | '-.' | 'none'

Line style, specified as the comma-separated pair consisting of 'LineStyle' and a line style specifier. This table lists supported line styles.

Specifier	Line Style
'-'	Solid line (default)
'--'	Dashed line
':'	Dotted line
'-.'	Dash-dot line
'none'	No line

**Example:** 'LineStyle','-.'

## 'LineWidth' - Line width

0.5 (default) | scalar

Line width, specified as the comma-separated pair consisting of 'LineWidth' and a scalar. Specify the value in points, where one point equals 1/72 inches. If any markers are displayed, then LineWidth also sets the width of the marker edges.

**Example:** 'LineWidth',0.75

## 'Marker' - Marker symbol

'none' (default) | string

Marker symbol, specified as the comma-separated pair consisting of 'Marker' and a marker specifier. By default, a plot line does not have markers. You can add markers at each data point along the line by specifying a marker symbol.

This table lists supported marker symbols.

Specifier	Marker Symbol
'o'	Circle
'+'	Plus sign
'*'	Asterisk
'.'	Point
'x'	Cross
'square' or 's'	Square
'diamond' or 'd'	Diamond
'^'	Upward-pointing triangle
'v'	Downward-pointing triangle

Specifier	Marker Symbol
'>'	Right-pointing triangle
'<'	Left-pointing triangle
'pentagram' or 'p'	Five-pointed star (pentagram)
'hexagram' or 'h'	Six-pointed star (hexagram)
'none'	No marker

**Example:** 'Marker', '+'

**Example:** 'Marker', 'diamond'

### 'MarkerEdgeColor' - Marker edge color

'auto' (default) | 'none' | three-element RGB vector | string

Marker edge color, specified as the comma-separated pair consisting of 'MarkerEdgeColor' and a color value. The color value can be one of the supported strings or an RGB vector, listed in the following tables.

Specifier	Result
'auto'	Uses same color as line color
'none'	Specifies no color, which makes unfilled markers invisible

For an RGB vector, use a three-element row vector whose elements specify the intensities of the red, green, and blue components of the color. The intensities must be in the range [0 1]. This table lists the predefined string colors and their RGB equivalents.

RGB Vector	Short Name	Long Name
[1 1 0]	'y'	'yellow'
[1 0 1]	'm'	'magenta'
[0 1 1]	'c'	'cyan'

RGB Vector	Short Name	Long Name
[1 0 0]	'r'	'red'
[0 1 0]	'g'	'green'
[0 0 1]	'b'	'blue'
[1 1 1]	'w'	'white'
[0 0 0]	'k'	'black'

**Example:** `'MarkerEdgeColor',[1 .8 .1]`

### 'MarkerFaceColor' - Marker face color

'none' (default) | 'auto' | three-element RGB vector | string

Marker face color, specified as the comma-separated pair consisting of 'MarkerFaceColor' and a color value. `MarkerFaceColor` sets the fill color for markers that are closed shapes (circle, square, diamond, pentagram, hexagram, and the four triangles). The color value can be one of the supported strings or an RGB vector, listed in the following tables.

Specifier	Result
'auto'	Uses the value of the axes <code>Color</code> property to fill the markers. If the axes <code>Color</code> property is 'none', then <code>plot</code> uses the figure <code>Color</code> value instead.
'none'	Makes the interior of the marker transparent, allowing the background to show through (default).

For an RGB vector, use a three-element row vector whose elements specify the intensities of the red, green, and blue components of the color. The intensities must be in the range [0 1]. This table lists the predefined string colors and their RGB equivalents.

RGB Vector	Short Name	Long Name
[1 1 0]	'y'	'yellow'
[1 0 1]	'm'	'magenta'
[0 1 1]	'c'	'cyan'
[1 0 0]	'r'	'red'
[0 1 0]	'g'	'green'
[0 0 1]	'b'	'blue'
[1 1 1]	'w'	'white'
[0 0 0]	'k'	'black'

**Example:** 'MarkerFaceColor',[0 .8 1]

### 'MarkerSize' - Marker size

6 (default) | scalar

Marker size, specified as the comma-separated pair consisting of 'MarkerSize' and a scalar in points.

**Example:** 'MarkerSize',3.75

## Output Arguments

### h - One or more lineseries handles

scalar | vector

One or more lineseries handles, returned as a scalar or a vector. These are unique identifiers, which you can use to query and modify properties of a specific line.

## Examples

### Create Line Plot

Define  $x$  as a vector of linearly spaced values between 0 and  $2\pi$ . Use an increment of  $\pi/100$  between the values. Define  $y$  as sine values of  $x$ .

```
x = 0:pi/100:2*pi;
y = sin(x);
```

# plot

---

Create a line plot of the data.

```
figure % opens new figure window
plot(x,y)
```

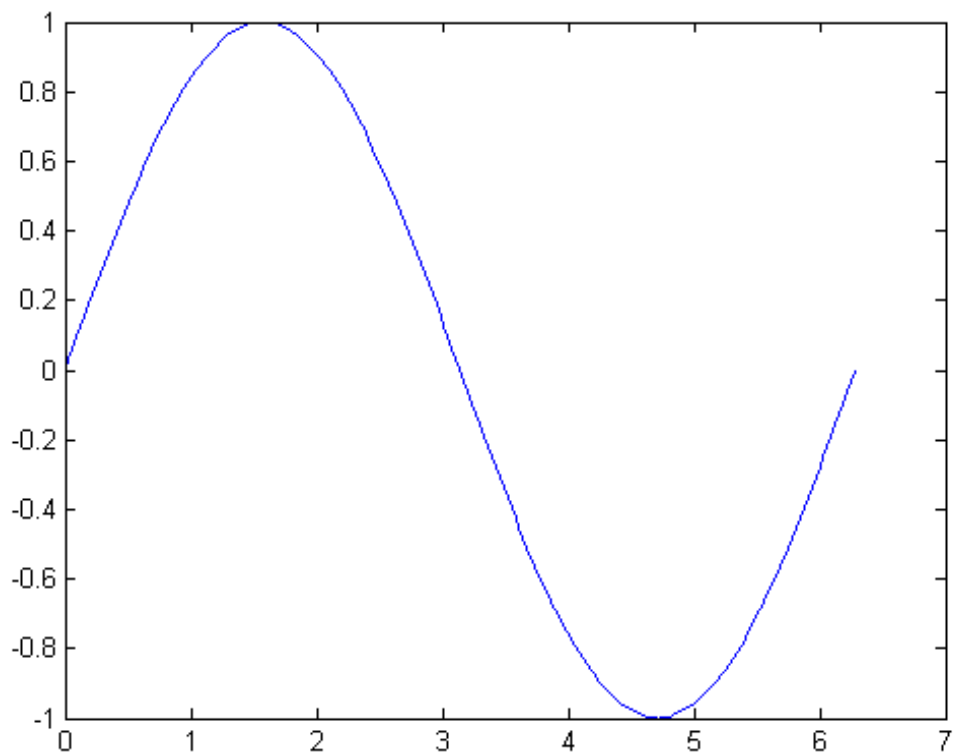

## Plot Multiple Lines

Define  $x$  as 100 linearly spaced values between  $-2\pi$  and  $2\pi$ . Define  $y_1$  and  $y_2$  as sine and cosine values of  $x$ . Create a line plot of both sets of data.

```
x = linspace(-2*pi,2*pi);
y1 = sin(x);
y2 = cos(x);

figure
plot(x,y1,x,y2)
```

# plot

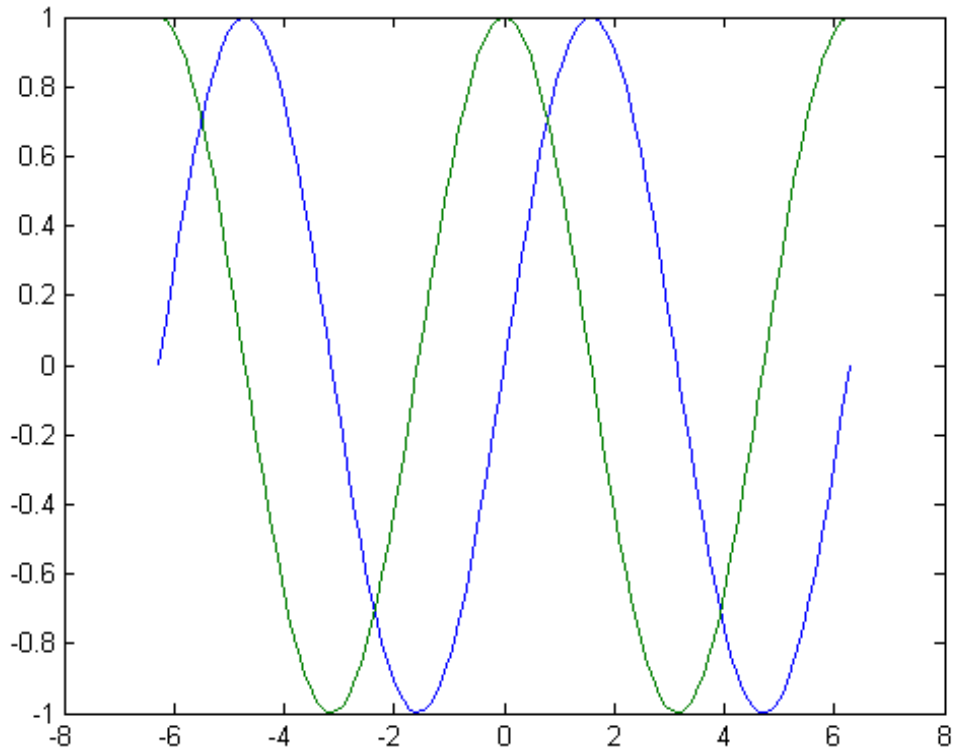

## Create Line Plot From Matrix

Define  $Y$  as the 4-by-4 matrix returned by the `magic` function.

```
Y = magic(4)
```

```
Y =
```

```
 16 2 3 13
```



```
5 11 10 8
9 7 6 12
4 14 15 1
```

Create a 2-D line plot of Y. MATLAB® plots each matrix column as a separate line.

```
figure
plot(Y)
```

# plot

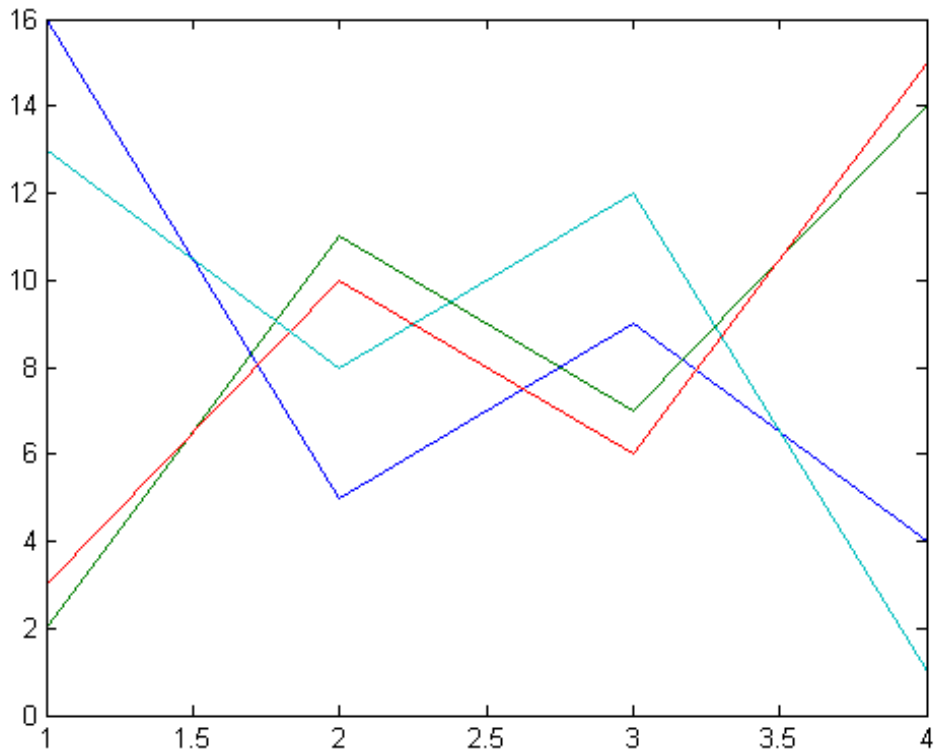

## Specify Line Style

Plot three sine curves with a small phase shift between each line. Use the default line style for the first line. Specify a dashed line style for the second line and a dotted line style for the third line.

```
x = 0:pi/100:2*pi;
y1 = sin(x);
y2 = sin(x-0.25);
y3 = sin(x-0.5);
```

```
figure
plot(x,y1,x,y2,'--',x,y3,':')
```

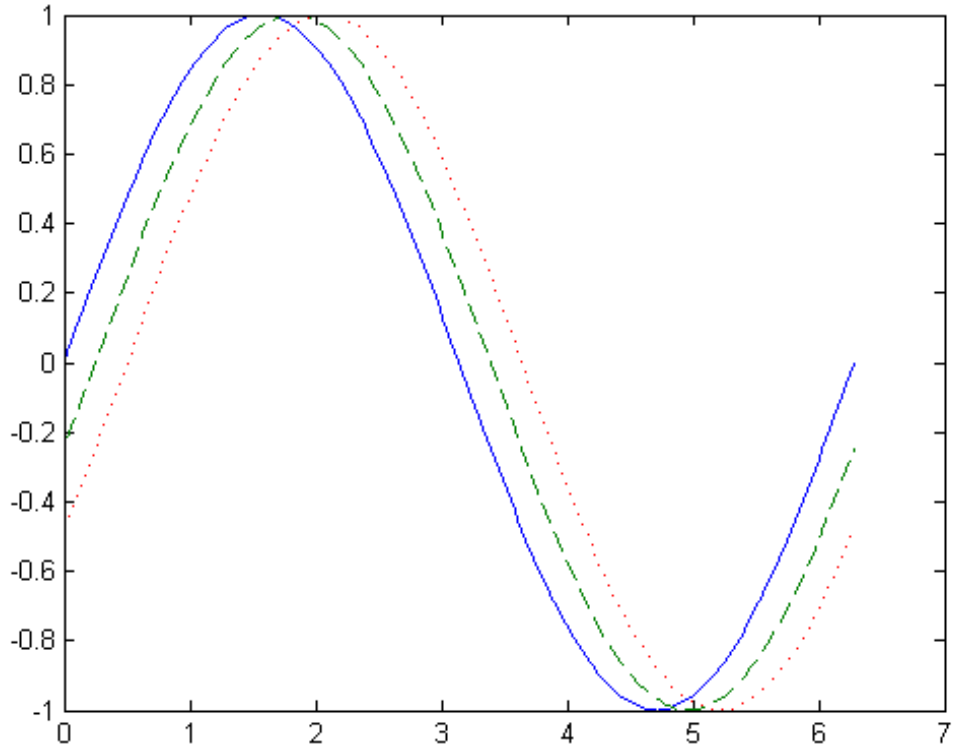

MATLAB® cycles the line color through the default color order.

### **Specify Line Style, Color, and Marker**

Plot three sine curves with a small phase shift between each line. Use a green line with no markers for the first sine curve. Use a blue dashed

# plot

---

line with circle markers for the second sine curve. Use only cyan star markers for the third sine curve.

```
x = 0:pi/10:2*pi;
y1 = sin(x);
y2 = sin(x-0.25);
y3 = sin(x-0.5);

figure
plot(x,y1,'g',x,y2,'b-o',x,y3,'c*')
```

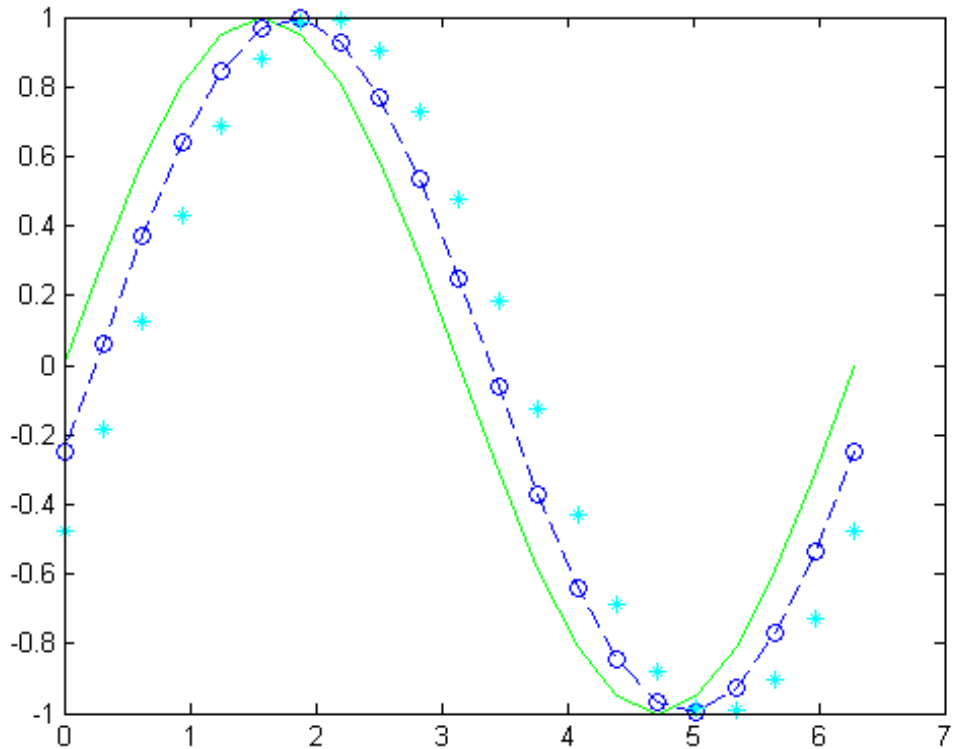

### Specify Line Width, Marker Size, and Marker Color

Create a line plot and use the `LineStyle` option to specify a dashed green line with square markers. Use `Name,Value` pairs to specify the line width, marker size, and marker colors. Set the marker edge color to blue and set the marker face color using an RGB color value.

```
x = -pi:pi/10:pi;
y = tan(sin(x)) - sin(tan(x));
```

# plot

```
figure
plot(x,y,'--gs',...
 'LineWidth',2,...
 'MarkerSize',10,...
 'MarkerEdgeColor','b',...
 'MarkerFaceColor',[0.5,0.5,0.5])
```

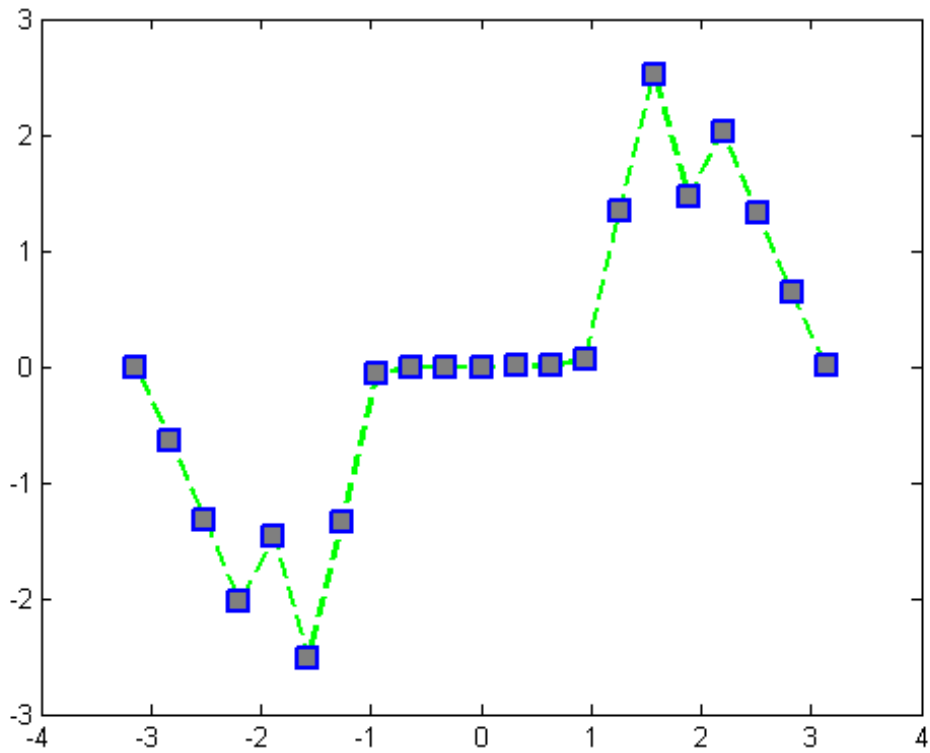

## Add Title and Axis Labels

Use the `linspace` function to define `x` as a vector of 150 values between 0 and 10. Define `y` as cosine values of `x`.

```
x = linspace(0,10,150);
y = cos(5*x);
```

Create a 2-D line plot of the cosine curve. Change the line color to a shade of blue-green using an RGB color value. Add a title and axis labels to the graph using the `title`, `xlabel`, and `ylabel` functions.

```
figure
plot(x,y,'Color',[0,0.7,0.9])

title('2-D Line Plot')
xlabel('x')
ylabel('cos(5x)')
```

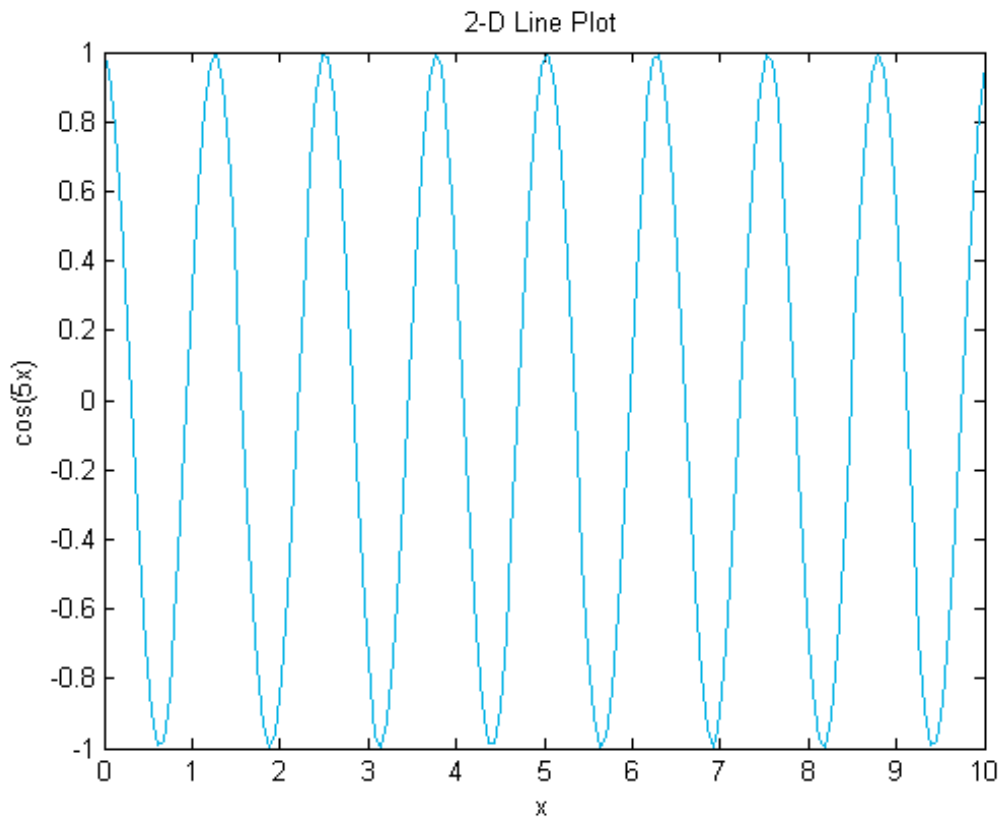

## Specify Axes for Line Plot

Create a figure with two subplots and return the handle to each subplot axes, `s(1)` and `s(2)`.

```
figure; % new figure
s(1) = subplot(2,1,1); % top subplot
s(2) = subplot(2,1,2); % bottom subplot
```



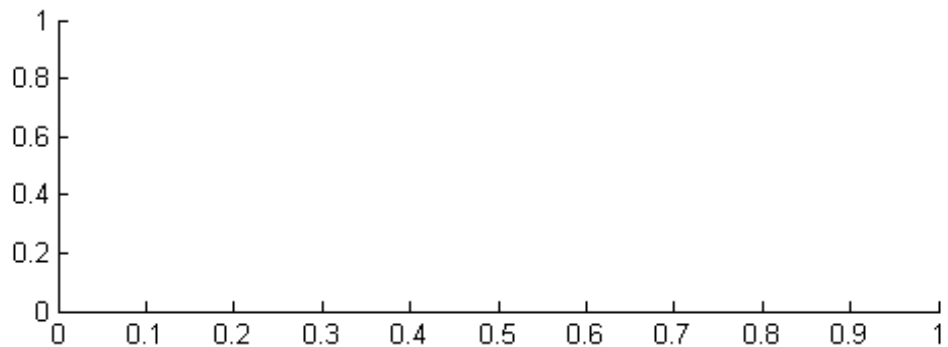
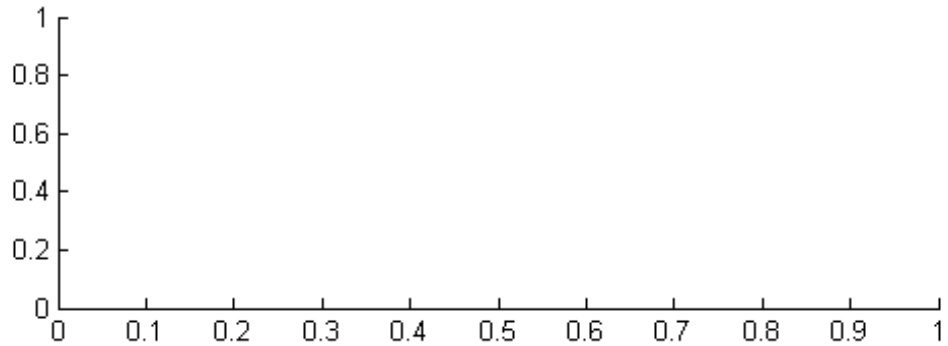

Create a 2-D line plot in each axes by referring to the axes handles. Add a title and  $y$ -axis label to each axes by passing the axes handles to the `title` and `ylabel` functions.

```
x = linspace(0,3);
y1 = sin(5*x);
y2 = sin(15*x);

plot(s(1),x,y1)
title(s(1),'Top Subplot')
```

# plot

---

```
ylabel(s(1), 'sin(5x)')

plot(s(2), x, y2)
title(s(2), 'Bottom Subplot')
ylabel(s(2), 'sin(15x)')
```

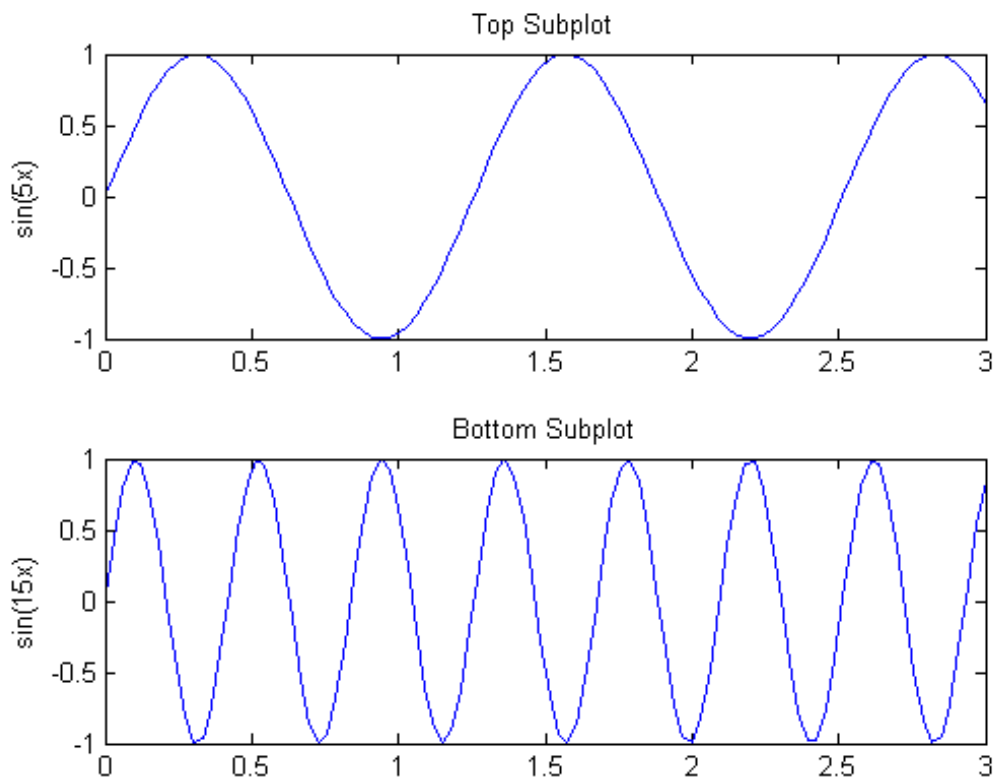

## Change Line Properties Using Handles

Define  $x$  as 100 linearly spaced values between  $-2\pi$  and  $2\pi$ . Define  $y_1$  and  $y_2$  as sine and cosine values of  $x$ . Create a line plot of both sets of data and return the handles of the two lines in  $h$ .

```
x = linspace(-2*pi,2*pi);
y1 = sin(x);
y2 = cos(x);

figure
h = plot(x,y1,x,y2);
```

# plot

---

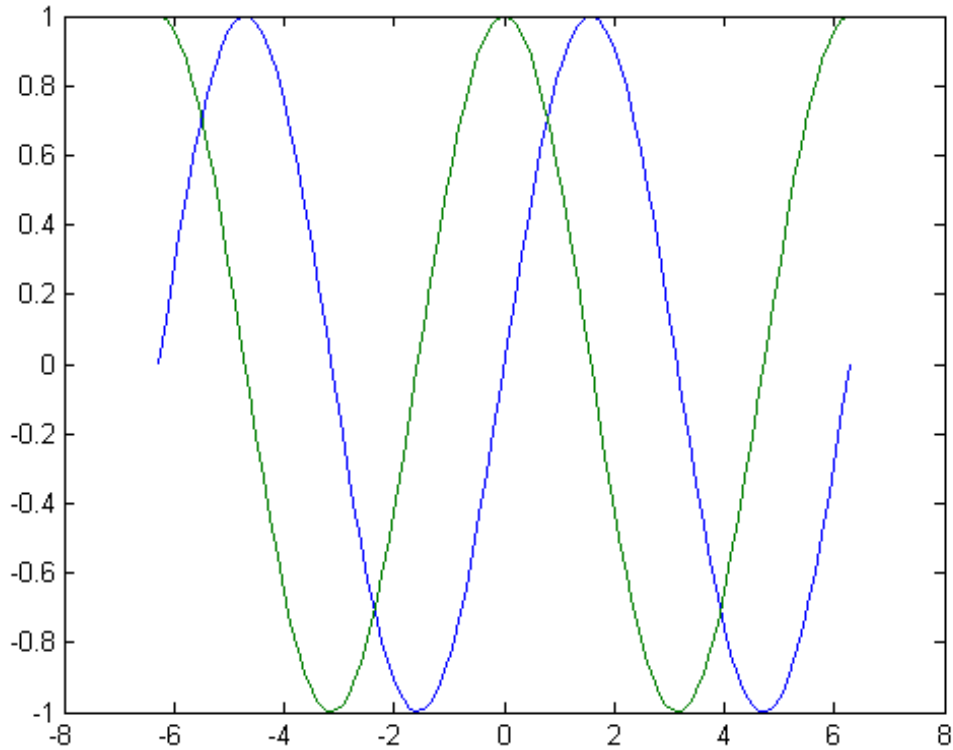

Use the handle of the first line, `h(1)`, to change the line width to 2.  
Use the handle of the second line, `h(2)`, to add star markers to the plotted line.

```
set(h(1), 'LineWidth', 2);
set(h(2), 'Marker', '*');
```

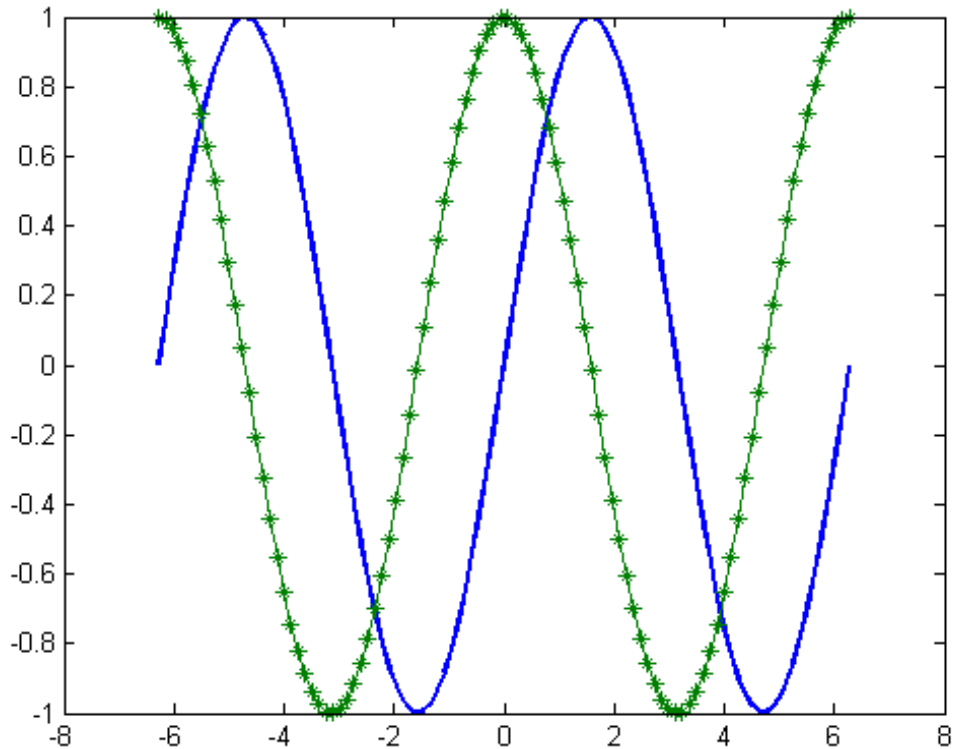
**Tips**

- `plot` automatically chooses colors and line styles in the order specified by the `ColorOrder` and `LineStyleOrder` properties of the current axes. `plot` cycles through the color order with the first line style. Then, `plot` cycles through it again with each additional line style.

To change the color and line style orders for the current axes, set the `ColorOrder` and `LineStyleOrder` axes properties. If you do not specify these properties, then `plot` uses the default values. For

# plot

---

example, to set the line style order for the current axes to a solid line with asterisk markers, a dotted line, and circle markers with no line, use this command:

```
set(gca, 'LineStyleOrder', '-*|:|o')
```

- Data can include NaN and inf values, which cause breaks in the lines drawn. For example, this code plots the first two elements, skips the third element, and draws another line using the last two elements:  
`plot([1,2,NaN,4,5]).`

## See Also

`title` | `xlabel` | `ylabel` | `xlim` | `ylim` | `legend` | `hold` | `LineStyleOrder` | `gca`

**Purpose**

3-D line plot

**Syntax**

```
plot3(X1,Y1,Z1,...)
plot3(X1,Y1,Z1,LineStyle,...)
plot3(...,'PropertyName',PropertyValue,...)
plot3(axes_handle,...)
h = plot3(...)
```

**Description**

The `plot3` function displays a three-dimensional plot of a set of data points.

`plot3(X1,Y1,Z1,...)`, where `X1`, `Y1`, `Z1` are vectors or matrices, plots one or more lines in three-dimensional space through the points whose coordinates are the elements of `X1`, `Y1`, and `Z1`.

`plot3(X1,Y1,Z1,LineStyle,...)` creates and displays all lines defined by the `Xn`, `Yn`, `Zn`, `LineStyle` quads, where `LineStyle` is a line specification that determines line style, marker symbol, and color of the plotted lines.

`plot3(...,'PropertyName',PropertyValue,...)` sets line properties to the specified property values for all the lines created by `plot3`. See `lineseries` properties for a description of the properties you can set.

`plot3(axes_handle,...)` plots into the axes specified by `axes_handle` instead of into the current axes (`gca`). The option, `axes_handle` can precede any of the input combinations in the previous syntaxes.

`h = plot3(...)` returns a column vector of `lineseries` handles, with one handle per object.

**Tips**

If one or more of `X1`, `Y1`, `Z1` is a vector, the vectors are plotted versus the rows or columns of the matrix, depending whether the vectors' lengths equal the number of rows or the number of columns.

# plot3

---

You can mix  $X_n, Y_n, Z_n$  triples with  $X_n, Y_n, Z_n, \text{LineStyle}$  quads, for example,

```
plot3(X1,Y1,Z1,X2,Y2,Z2,LineStyle,X3,Y3,Z3)
```

See `LineStyle` and `plot` for information on line types and markers.

## Examples

### Plot 3-D Helix

Define  $t$  as values between 0 and  $10\pi$ . Define  $st$  and  $ct$  as vectors of sine and cosine values. Plot a 3-D helix.

```
t = 0:pi/50:10*pi;
st = sin(t);
ct = cos(t);
```

```
figure
plot3(st,ct,t)
```

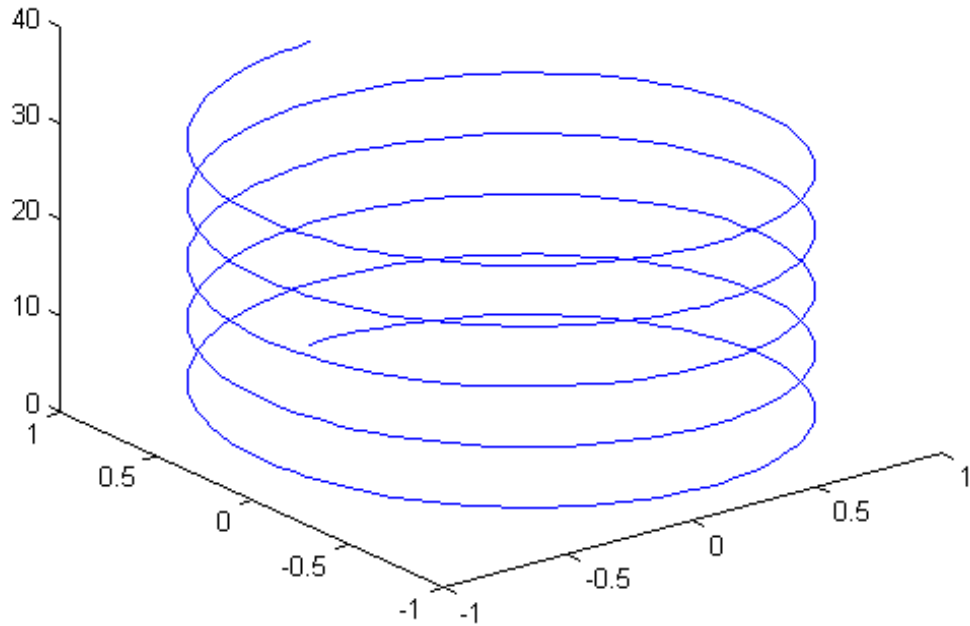

**See Also**

[axis](#) | [bar3](#) | [grid](#) | [line](#) | [LineStyle](#) | [loglog](#) | [plot](#) | [scatter3](#) | [semilogx](#) | [semilogy](#) | [subplot](#)

**Purpose** Show or hide figure **Plot Browser**



**Syntax**

```
plotbrowser('on')
plotbrowser('off')
plotbrowser
plotbrowser(figure_handle,...)
```

**Description**

`plotbrowser('on')` displays the Plot Browser on the current figure.

`plotbrowser('off')` hides the Plot Browser on the current figure.



`plotbrowser` toggles the visibility of the Plot Browser on the current figure. You can use `plotbrowser('toggle')` instead for the same functionality.

`plotbrowser(figure_handle,...)` shows or hides the Plot Browser on the figure specified by *figure\_handle*.

**Tips**

If you call `plotbrowser` in a MATLAB program and subsequent lines depend on the Plot Browser being fully initialized, follow it by `drawnow` to ensure complete initialization.

**Alternatives**

To collectively enable **Plotting Tools**, use the large Plotting Tool icon  on the figure toolbar. To collectively disable the **Plotting Tools**, use the smaller icon . Open or close the **Plot Browser** tool from the figure's **View** menu.

**See Also** `plottools` | `figurepalette` | `propertyeditor`

**Purpose** Interactively edit and annotate plots

**Syntax**

```
plottedit on
plottedit off
plottedit
plottedit(h)
plottedit('state')
plottedit(h,'state')
```

**Description** `plottedit on` starts plot edit mode for the current figure, allowing you to use a graphical interface to annotate and edit plots easily. In plot edit mode, you can label axes, change line styles, and add text, line, and arrow annotations.

`plottedit off` ends plot mode for the current figure.

`plottedit` toggles the plot edit mode for the current figure.

`plottedit(h)` toggles the plot edit mode for the figure specified by figure handle `h`.

`plottedit('state')` specifies the `plottedit` state for the current figure. Values for `state` can be as shown.

Value for state	Description
on	Starts plot edit mode
off	Ends plot edit mode
showtoolsmenu	Displays the <b>Tools</b> menu in the menu bar
hidetoolsmenu	Removes the <b>Tools</b> menu from the menu bar

**Note** `hidetoolsmenu` is intended for GUI developers who do not want the **Tools** menu to appear in applications that use the figure window.

`plottedit(h, 'state')` specifies the plottedit state for figure handle `h`.

## Tips

### Plot Editing Mode Graphical Interface Components

To start plot edit mode, click this button.

Use these toolbar buttons to add a legend, text, and arrows.

Use the **Edit**, **Insert**, and **Tools** menus to add objects or edit existing objects in a graph.

Double-click on an object to select it.

Position labels, legends, and other objects by clicking and dragging.

Access object-specific plot edit functions through context-sensitive pop-up menus.

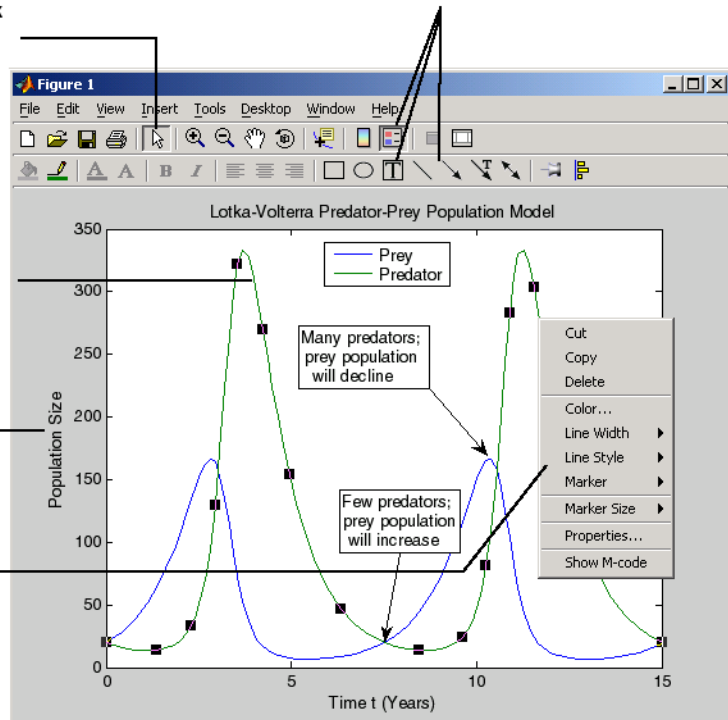

## Examples

Start plot edit mode for figure 2.

```
plottedit(2)
```

End plot edit mode for figure 2.

```
plottedit(2, 'off')
```

Hide the **Tools** menu for the current figure:

```
plottedit('hidetoolsmenu')
```

**See Also**

[axes](#) | [line](#) | [open](#) | [plot](#) | [print](#) | [saveas](#) | [text](#) | [propedit](#)

# plotmatrix

---

**Purpose** Scatter plot matrix

**Syntax** `plotmatrix(X,Y)`  
`plotmatrix(X)`  
`plotmatrix( ___,LineStyle)`

`[H,AX,BigAx,P,PAx] = plotmatrix( __ )`

**Description** `plotmatrix(X,Y)` creates a matrix of subaxes containing scatter plots of the columns of  $X$  against the columns of  $Y$ . If  $X$  is  $p$ -by- $n$  and  $Y$  is  $p$ -by- $m$ , then `plotmatrix` produces an  $n$ -by- $m$  matrix of subaxes.

`plotmatrix(X)` is the same as `plotmatrix(X,X)` except that the subaxes along the diagonal are replaced with histogram plots of the data in the corresponding column of  $X$ . For example, the subaxes along the diagonal in the  $i$ th column is replaced by `hist(X(:,i))`.

`plotmatrix( ___,LineStyle)` specifies the line style, marker symbol, and color for the scatter plots. The option `LineStyle` can be preceded by any of the input argument combinations in the previous syntaxes.

`[H,AX,BigAx,P,PAx] = plotmatrix( __ )` returns handles to the graphic objects created as follows:

- `H` – Matrix of handles to the line objects used to create the scatter plots
- `AX` – Matrix of handles to the individual subaxes
- `BigAx` – Handle to the big axes that frames the subaxes
- `P` – Vector of handles for the patch objects that create the histogram plots
- `PAx` – Vector of handles to the invisible histogram axes

`BigAx` is left as the current axes (`gca`) so that a subsequent `title`, `xlabel`, or `ylabel` command will center text with respect to the big axes.

## Input Arguments

### X - Data to display

matrix

Data to display, specified as a matrix.

#### Data Types

single | double | int8 | int16 | int32 | int64 | uint8 | uint16 | uint32 | uint64 | logical

### Y - Data to plot against X

matrix

Data to plot against X, specified as a matrix.

#### Data Types

single | double | int8 | int16 | int32 | int64 | uint8 | uint16 | uint32 | uint64 | logical

### LineStyle - Line style, marker symbol, and color for scatter plots

string

Line style, marker symbol, and color for the scatter plots, specified as a string. For more information on line style, marker symbol, and color options see LineSpec.

**Example:** `':*r'`

#### Data Types

char

## Output Arguments

### H - Line object handles

matrix

Line object handles, returned as a matrix. This is a unique identifier, which you can use to query and modify the properties of a specific line object. The line objects are used to create the scatter plots.

### AX - Subaxes handles

matrix

Subaxes handles, returned as a matrix. This is a unique identifier, which you can use to query and modify the properties of a specific subaxes.

## **BigAx - Big axes handle**

scalar

Big axes handle, returned as a scalar. This is a unique identifier, which you can use to query and modify properties of the big axes. **BigAx** is left as the current axes (`gca`) so that a subsequent `title`, `xlabel`, or `ylabel` command will center text with respect to the big axes.

## **P - Patch object handles**

vector | []

Patch object handles, returned as a vector or []. If histogram plots are created, then **P** is returned as a vector of patch object handles for the histogram plots. These are unique identifiers, which you can use to query and modify the properties of a specific patch object. If no histogram plots are created, then **P** is returned as empty brackets.

## **PAX - Handle to invisible histogram axes**

vector | []

Handle to invisible histogram axes, returned as a vector or []. If histogram plots are created, then **PAX** is returned as a vector of histogram axes handles. These are unique identifiers, which you can use to query and modify the properties of a specific axes, such as the axes scale. If no histogram plots are created, then **PAX** is returned as empty brackets.

## **Examples**

### **Create Scatter Plot Matrix with Two Matrix Inputs**

Initialize the random-number generator to make the output of `randn` repeatable. Define **X** as a matrix of normally distributed pseudorandom data and **Y** as a matrix of integer values.

```
rng(0,'twister');
X = randn(50,3);
```



```
Y = reshape(1:150,50,3);
```

Create a scatter plot matrix of the columns of X against the columns of Y.

```
figure
plotmatrix(X,Y)
```

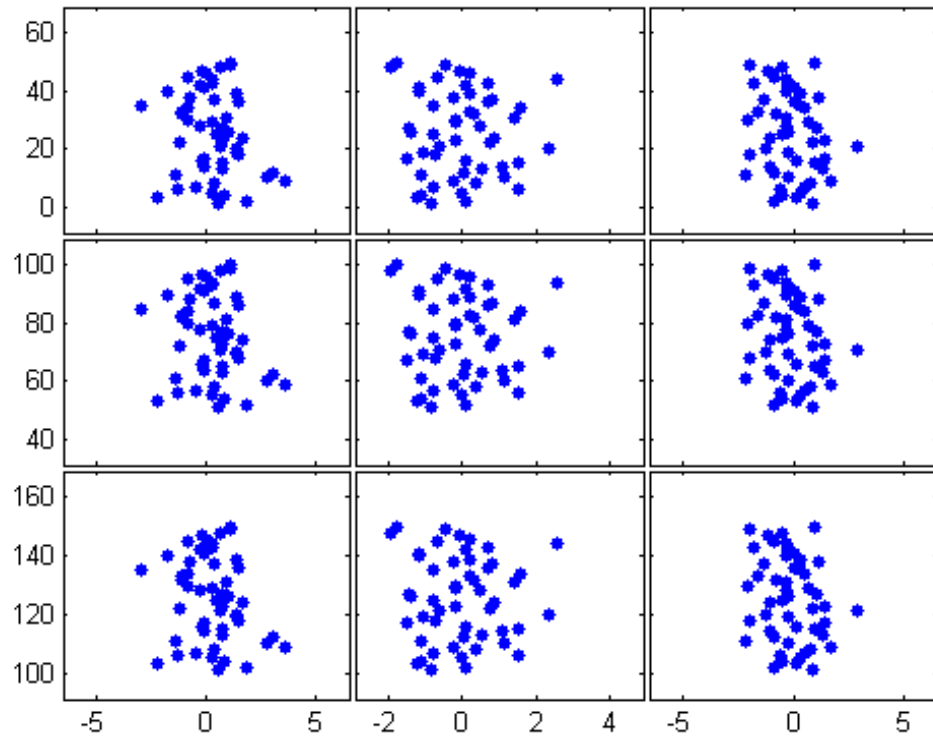

The subplot in the  $i$ th row,  $j$ th column of the figure is a scatter plot of the  $i$ th column of Y against the  $j$ th column of X.

## Create Scatter Plot Matrix with One Matrix Input

Initialize the random-number generator to make the output of `randn` repeatable and generate a matrix of normally distributed pseudorandom data

```
rng(0, 'twister');
X = randn(50,3);
```

Create a scatter plot matrix.

```
figure
plotmatrix(X)
```

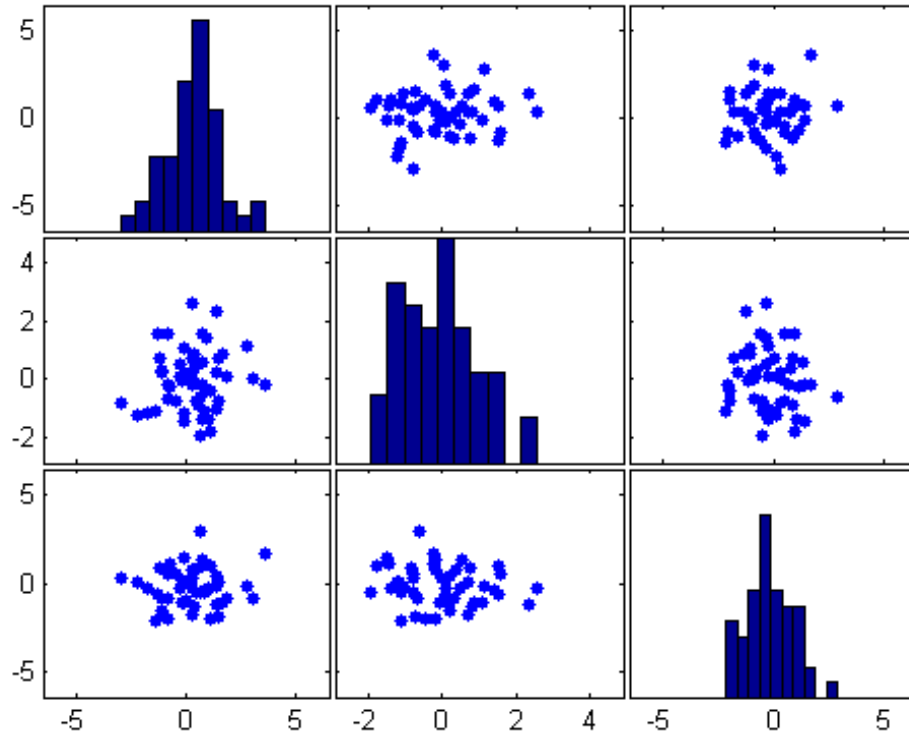

The subplot in the  $i$ th row,  $j$ th column of the matrix is a scatter plot of the  $i$ th column of  $X$  against the  $j$ th column of  $X$ . Along the diagonal, `plotmatrix` creates a histogram plot of each column of  $X$ .

### **Specify Marker Type and Color**

Initialize the random-number generator to make the output of `randn` repeatable. Generate a matrix of normally distributed pseudorandom data.

# plotmatrix

---

```
rng(0,'twister');
X = randn(50,3);
```

Create a scatter plot matrix and specify the marker type and the color for the scatter plots.

```
figure
plotmatrix(X, '*r')
```

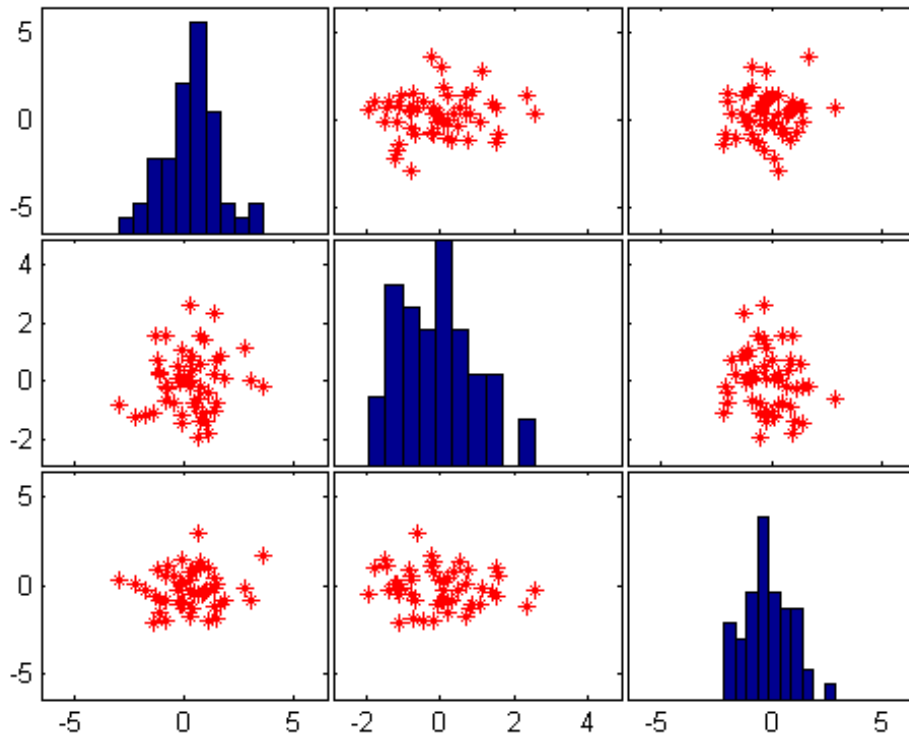

The `LineStyle` option sets properties for the scatter plots. To set properties for the histogram plots, use the patch object handles.

### **Set Plotmatrix Properties Using Handles**

Initialize the random-number generator to make the output of `randn` repeatable. Generate a matrix of normally distributed pseudorandom data.

```
rng(0, 'twister');
X = randn(50,3);
```

Create a scatter plot matrix and return the object handles and the axes handles.

```
figure
[H,AX,BigAx,P,PAx] = plotmatrix(X);
```

# plotmatrix

---

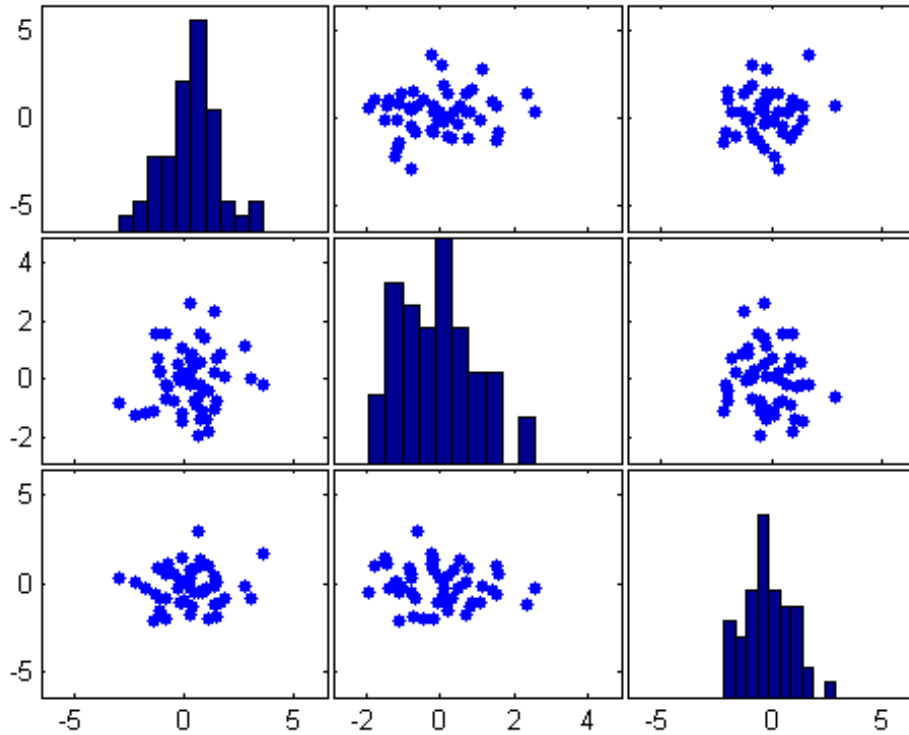

To set properties for the scatter plots, use the handles in H. To set properties for the histograms, use the patch handles in P. To set axes properties, use the axes handles, AX, BigAX, and PAX.

Set the color and marker type for the scatter plot in the lower left corner.

```
set(H(3), 'Color', 'g', 'Marker', '*');
```

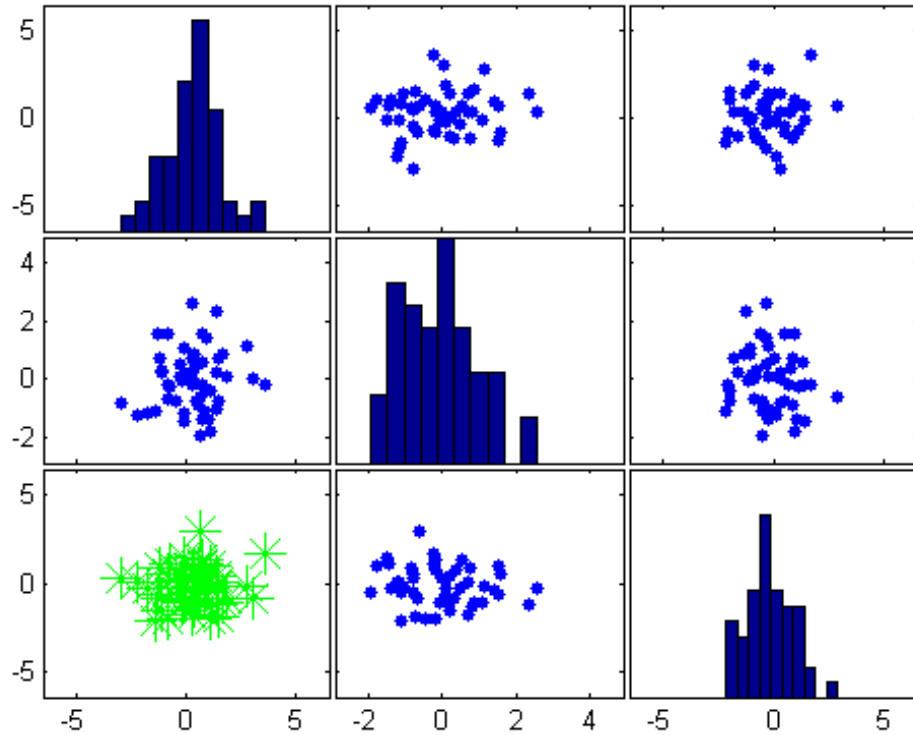

Set the color for the histogram plot in the lower right corner. Use the `title` command to title the figure.

```
set(P(3),'EdgeColor','k','FaceColor','g');
title(BigAx,'A Comparison of Data Sets');
```

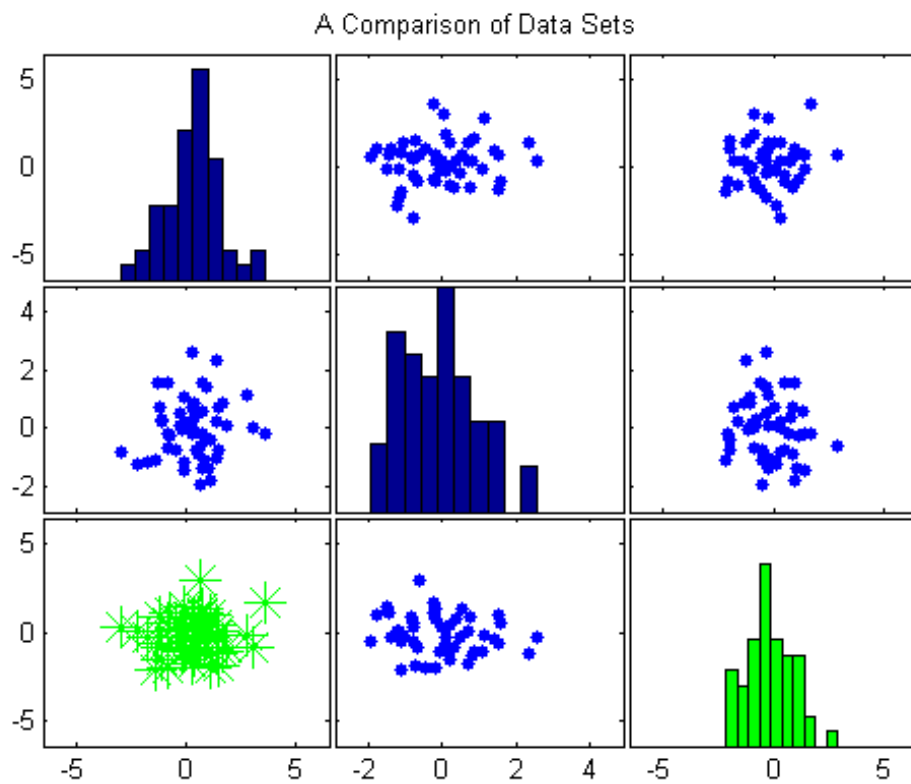

**See Also** [scatter](#) | [scatter3](#)



**Purpose** Show or hide plot tools

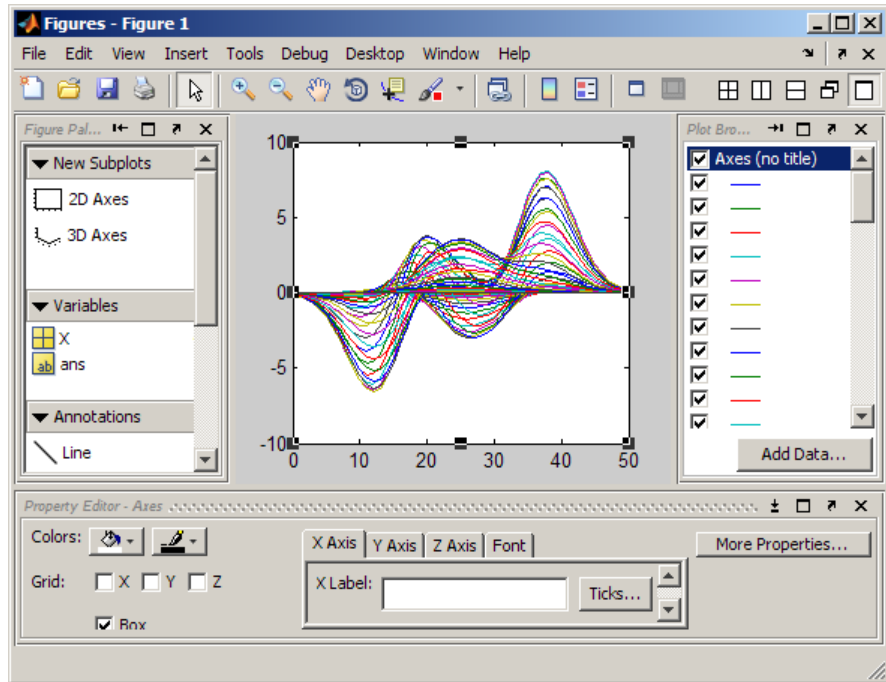

**Syntax**

```

plottools('on')
plottools('off')
plottools
plottools(figure_handle,...)
plottools(..., 'tool')

```

**Description**

`plottools('on')` displays the Figure Palette, Plot Browser, and Property Editor on the current figure, configured as you last used them.

`plottools('off')` hides the Figure Palette, Plot Browser, and Property Editor on the current figure.

`plottools` with no arguments, is the same as `plottools('on')`

# plottools

---

`plottools(figure_handle, ...)` displays or hides the plot tools on the specified figure instead of on the current figure.

`plottools(..., 'tool')` operates on the specified tool only. *tool* can be one of the following strings:



- `figurepalette`
- `plotbrowser`
- `propertyeditor`

---

**Note** The first time you open the plotting tools, all three of them appear, grouped around the current figure as shown above. If you close, move, or undock any of the tools, MATLAB remembers the configuration you left them in and restores it when you invoke the tools for subsequent figures, both within and across MATLAB sessions.

---

## Alternatives

Click the larger **Plotting Tools** icon  on the figure toolbar to collectively enable plotting tools, and the smaller icon  to collectively disable them. Individually select the **Figure Palette**, **Plot Browser**, and **Property Editor** tools from the figure's **View** menu. For details, see “Customize Graph Using Plot Tools”.

## See Also

`figurepalette` | `plotbrowser` | `propertyeditor`

## Purpose

2-D line plots with y-axes on both left and right side

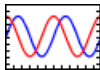

## Syntax

```
plotyy(X1,Y1,X2,Y2)
plotyy(X1,Y1,X2,Y2,function)
plotyy(X1,Y1,X2,Y2,'function1','function2')
[AX,H1,H2] = plotyy(...)
```

## Description

`plotyy(X1,Y1,X2,Y2)` plots  $X1$  versus  $Y1$  with  $y$ -axis labeling on the left and plots  $X2$  versus  $Y2$  with  $y$ -axis labeling on the right.

`plotyy(X1,Y1,X2,Y2,function)` uses the specified plotting function to produce the graph.

`function` can be either a function handle or a string specifying `plot`, `semilogx`, `semilogy`, `loglog`, `stem`, or any MATLAB function that accepts the syntax

```
h = function(x,y)
```

For example,

```
plotyy(x1,y1,x2,y2,@loglog) % function handle
plotyy(x1,y1,x2,y2,'loglog') % string
```

Function handles enable you to access user-defined local functions and can provide other advantages. See `@` for more information on using function handles.

`plotyy(X1,Y1,X2,Y2,'function1','function2')` uses `function1(X1,Y1)` to plot the data for the left axis and `function2(X2,Y2)` to plot the data for the right axis.

`[AX,H1,H2] = plotyy(...)` returns the handles of the two axes created in `AX` and the handles of the graphics objects from each plot in `H1` and `H2`. `AX(1)` is the left axes and `AX(2)` is the right axes.

## Examples

### Plot Two Data Sets with Different y-Axes

Plot two data sets on one graph using two y-axes.

```
x = 0:0.01:20;
y1 = 200*exp(-0.05*x).*sin(x);
y2 = 0.8*exp(-0.5*x).*sin(10*x);
```

```
figure % new figure
plotyy(x,y1,x,y2);
```

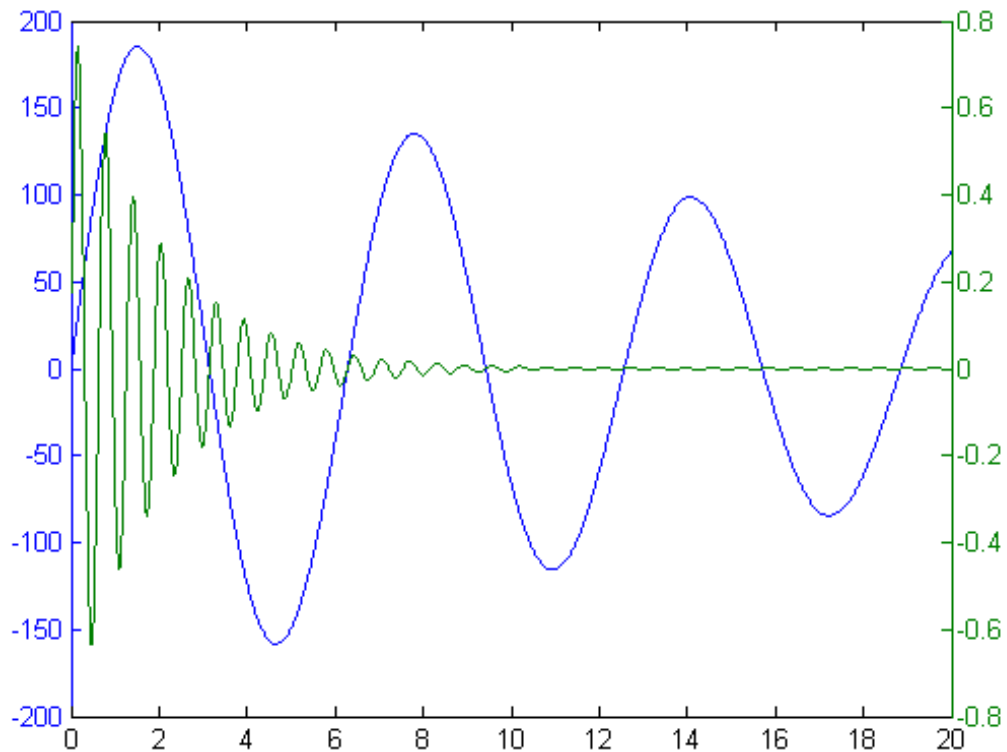

## Add Title and Axis Labels

Plot two data sets using a graph with two y-axes. Add a title and axis labels.

```
x = 0:0.01:20;
y1 = 200*exp(-0.05*x).*sin(x);
y2 = 0.8*exp(-0.5*x).*sin(10*x);

figure % new figure
[hAx,hLine1,hLine2] = plotyy(x,y1,x,y2);

title('Multiple Decay Rates')
xlabel('Time (\musec)')

ylabel(hAx(1),'Slow Decay') % left y-axis
ylabel(hAx(2),'Fast Decay') % right y-axis
```

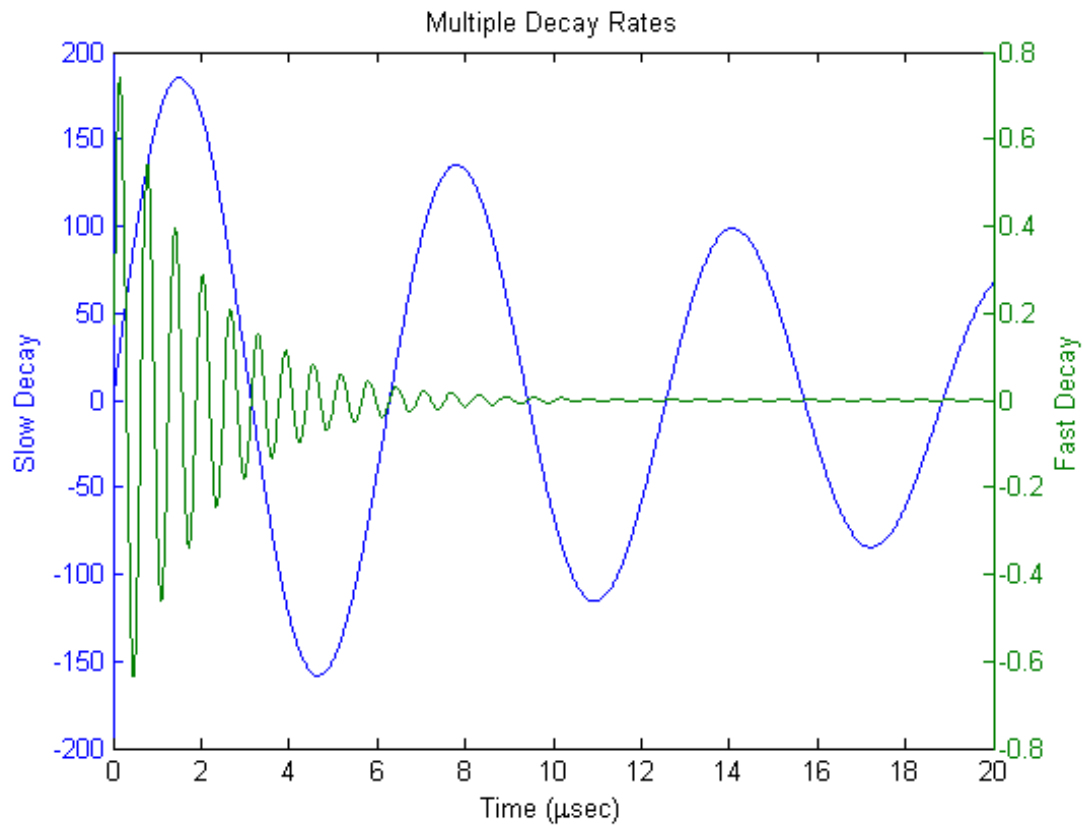

## Change Line Styles

Plot two data sets using a graph with two y-axes. Change the line styles.

```
x = 0:0.01:20;
y1 = 200*exp(-0.05*x).*sin(x);
y2 = 0.8*exp(-0.5*x).*sin(10*x);
```

```
figure % new figure
[hAx,hLine1,hLine2] = plotyy(x,y1,x,y2);
```

```
set(hLine1,'LineStyle','--')
set(hLine2,'LineStyle',':')
```

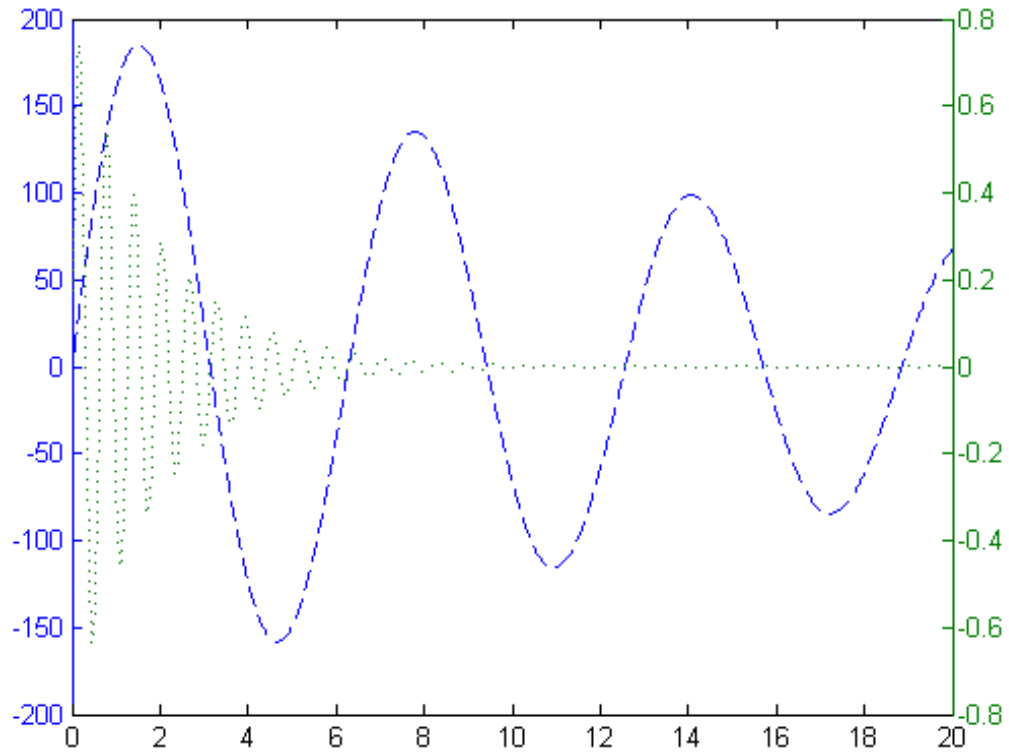

### Combine Different Types of Plots

Plot two data sets using a graph with two y-axes. Use a line plot for the data associated with the left y-axis. Use a stem plot for the data associated with the right y-axis.

# plotyy

```
x = 0:0.1:10;
y1 = 200*exp(-0.05*x).*sin(x);
y2 = 0.8*exp(-0.5*x).*sin(10*x);

figure
plotyy(x,y1,x,y2,'plot','stem');
```

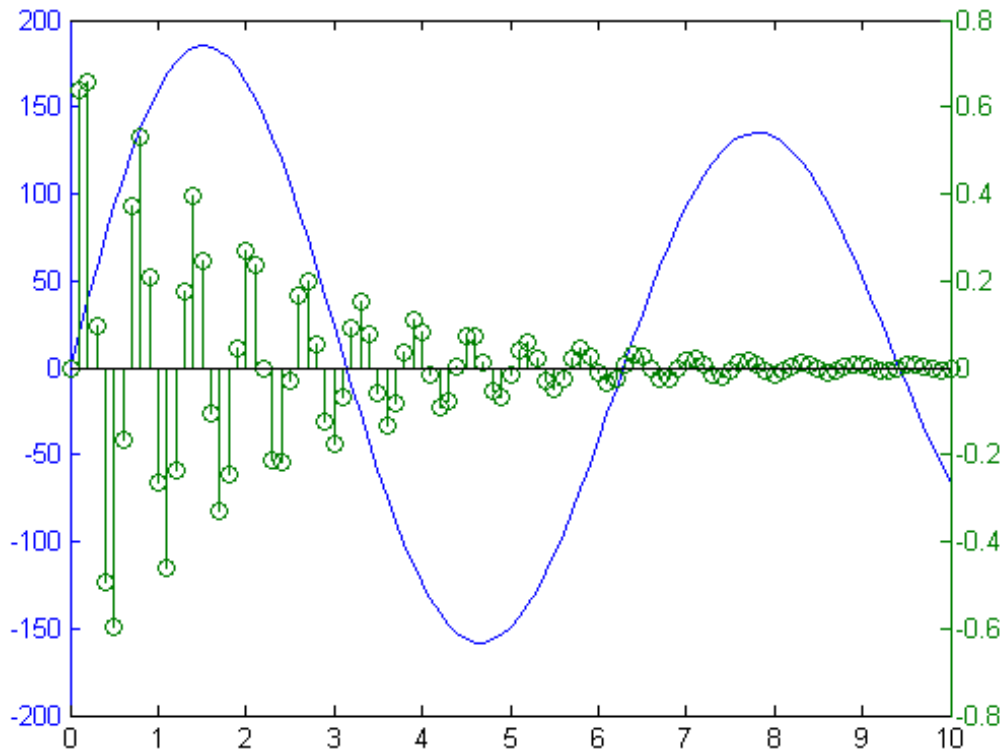



### Use Right y-Axis for Two Data Sets

Plot three data sets using a graph with two y-axes. Plot one set of data associated with the left y-axis. Plot two sets of data associated with the right y-axis by using two-column matrices.

```
x = linspace(0,10);
y1 = 200*exp(-0.05*x).*sin(x);
y2 = 0.8*exp(-0.5*x).*sin(10*x);
y3 = 0.2*exp(-0.5*x).*sin(10*x);

figure
[hAx,hLine1,hLine2] = plotyy(x,y1,[x',x'],[y2',y3']);
```

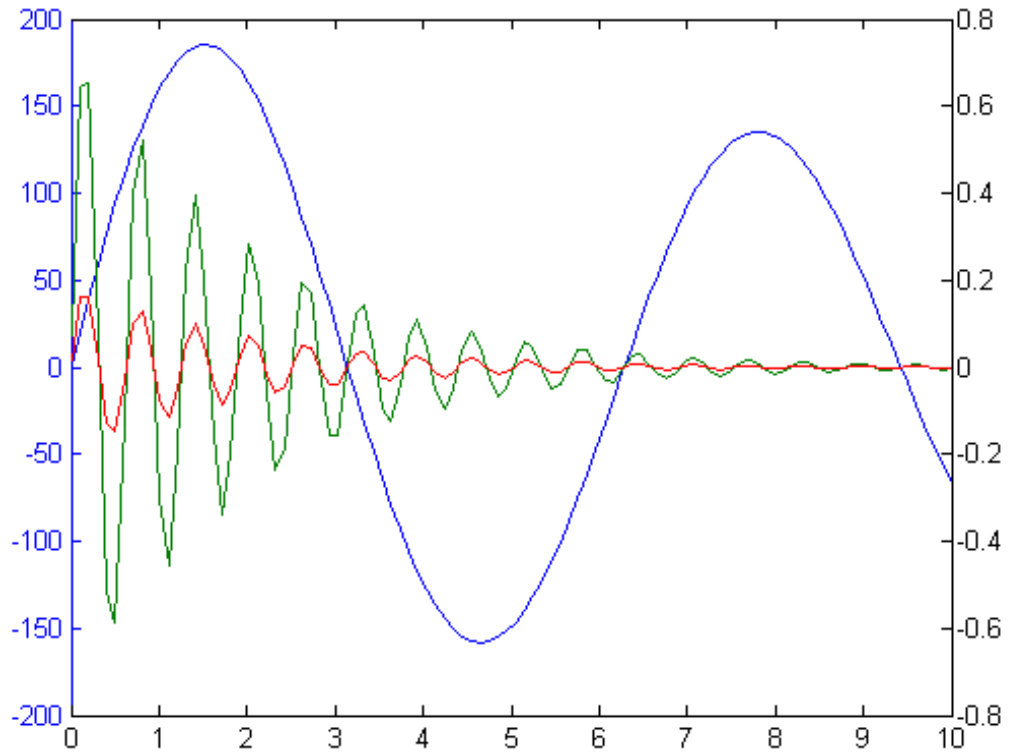

## See Also

[plot](#) | [linkaxes](#) | [linkprop](#) | [loglog](#) | [semilogx](#) | [semilogy](#) | [XAxisLocation](#) | [YAxisLocation](#)

## How To

- “Create Graph with Two y-Axes”
- “Graph with Multiple x-Axes and y-Axes”

## Purpose

Summary of classes in MATLAB Plugins Interface

## Description

Plugins customize a TestRunner object. The matlab.unittest.plugins package consists of the following customized MATLAB plugins.

matlab.unittest.plugins.DiagnosticsValidationPlugin Validate diagnostic code

matlab.unittest.plugins.FailureDiagnosticsPlugin Show diagnostics on failure

matlab.unittest.plugins.OutputStreamInterface Interface that determines where to send text output

matlab.unittest.plugins.StopOnFailurePlugin Debug test failures

matlab.unittest.plugins.TAPPlugin Plugin that produces Test Anything Protocol stream

matlab.unittest.plugins.TestRunnerPlugin Interface for extending TestRunner

matlab.unittest.plugins.TestSuiteProgressPlugin Outputs progress information as text

matlab.unittest.plugins.ToFile Output stream to write text output to file

matlab.unittest.plugins.ToStandardOutput Output stream to display text information to screen

## Related Examples

- “Add Plugin to Test Runner”
- “Write Plugins to Extend TestRunner”
- “Create Custom Plugin”

# matlab.unittest.plugins.DiagnosticsValidationPlugin

---

<b>Purpose</b>	Plugin to help validate diagnostic code
<b>Description</b>	<p>The <code>DiagnosticsValidationPlugin</code> creates a plugin to help validate diagnostic code.</p> <p>Add the <code>DiagnosticsValidationPlugin</code> to the <code>TestRunner</code> to confirm that user-supplied diagnostics execute correctly. This plugin is useful because typically tests do not encounter failure conditions. A failure can result in unexercised diagnostic code. If a programming error exists in this diagnostic code, the error is not evident unless the test fails. However, at this point in the testing process, the diagnostics for the failure condition are lost due to the error in the diagnostic code.</p> <p>Use this plugin to unconditionally evaluate the diagnostics supplied by the test writer, regardless of whether the test results in a passing or failing condition. This approach helps you to confirm that all of the diagnostic code is free from programming errors.</p> <p>The diagnostic analysis can reduce the test performance and can result in very verbose text output. Be aware of these impacts before using this plugin for routine testing.</p>
<b>Construction</b>	<p><code>matlab.unittest.plugins.DiagnosticsValidationPlugin</code> creates a plugin to help validate diagnostic code.</p> <p><code>matlab.unittest.plugins.DiagnosticsValidationPlugin(stream)</code> redirects all the text output to the output stream, <code>stream</code>. If you do not specify the output stream, the plugin uses the default <code>ToStandardOutput</code> stream.</p>
<b>Input Arguments</b>	<p><b>stream</b></p> <p>Location where the plugin directs text output, specified as an <code>OutputStream</code>.</p> <p><b>Default:</b> <code>ToStandardOutput</code></p>
<b>Copy Semantics</b>	Handle. To learn how handle classes affect copy operations, see <a href="#">Copying Objects</a> in the MATLAB documentation.

## Examples

### Add Plugin to TestRunner

In your working folder, create a file, `ExampleTest.m`, containing the following test class. In this example, the `testThree` method has an intentional error. The method should use a function handle to the `dir` function as a `FunctionHandleDiagnostic`, but `dir` is misspelled.

```
classdef ExampleTest < matlab.unittest.TestCase
 methods(Test)
 function testOne(testCase)
 % test code
 end
 function testTwo(testCase)
 % test code
 end
 function testThree(testCase)
 % The following should use @dir as a function handle,
 % but there is a typo
 testCase.verifyEqual('myfile','myfile', @dri);
 end
 end
end
```

All of the tests in `ExampleTest.m` result in a passing condition, but there is an error in the diagnostic.

At the command prompt, create a test suite from the `ExampleTest` class.

```
import matlab.unittest.TestRunner;
import matlab.unittest.TestSuite;
import matlab.unittest.plugins.DiagnosticsValidationPlugin;

suite = TestSuite.fromClass(?ExampleTest);
```

Create a test runner with no plugins. This code creates a silent runner and provides you with complete control over the installed plugins.

```
runner = TestRunner.withTextOutput;
```

# matlab.unittest.plugins.DiagnosticsValidationPlugin

---

Run the tests.

```
result1 = runner.run(suite);
```

```
Running ExampleTest
```

```
...
```

```
Done ExampleTest
```

---

No diagnostic output is displayed because all the tests passed. The testing framework does not encounter the bug in the `FunctionHandleDiagnostic` of `testThree`.

Add `DiagnosticsValidationPlugin` to the runner and run the tests.

```
runner.addPlugin(DiagnosticsValidationPlugin);
result2 = runner.run(suite);
```

```
Running ExampleTest
```

```
..
```

```

Validation of Test Diagnostic:

```

```
Error occurred while capturing diagnostics:
```

```
Error using evalc
```

```
Undefined function or variable 'dri'.
```

```
Error in ExampleTest/testThree (line 12)
```

```
 testCase.verifyEqual('myfile','myfile', @dri);
```

```
.
```

```
Done ExampleTest
```

---

The framework executes the diagnostic provided by the `FunctionHandleDiagnostic`, even though none of the tests fails. Without this plugin, the test framework only encounters the bug if the test fails.

# matlab.unittest.plugins.DiagnosticsValidationPlugin

---

## See Also

[matlab.unittest.plugins](#) | [matlab.unittest.diagnostics](#) | [OutputStream](#) | [ToStandardOutput](#)

## Concepts

# matlab.unittest.plugins.FailureDiagnosticsPlugin

---

<b>Purpose</b>	Plugin to show diagnostics on failure
<b>Description</b>	The <code>FailureDiagnosticsPlugin</code> creates a plugin to show diagnostics upon encountering a test failure. Add it to the <code>TestRunner</code> to output test failure diagnostics to the Command Window. This plugin is used by default when you construct a test runner using <code>TestRunner.withTextOutput</code> .
<b>Construction</b>	<code>matlab.unittest.plugins.FailureDiagnosticsPlugin</code> creates a plugin to show diagnostics upon encountering a test failure.  <code>matlab.unittest.plugins.DFailureDiagnosticsPlugin(stream)</code> redirects all the text output to the output stream, <code>stream</code> . If you do not specify the output stream, the plugin uses the <code>ToStandardOutput</code> stream.
<b>Input Arguments</b>	<b>stream</b>  Location where the plugin directs text output, specified as an <code>OutputStream</code> .  <b>Default:</b> <code>ToStandardOutput</code>
<b>Copy Semantics</b>	Handle. To learn how handle classes affect copy operations, see <a href="#">Copying Objects</a> in the MATLAB documentation.
<b>Examples</b>	<b>Add Plugin to TestRunner</b>  In your working folder, create a file, <code>ExampleTest.m</code> , containing the following test class.  <pre>classdef ExampleTest &lt; matlab.unittest.TestCase     methods(Test)         function testPathAdd(testCase)             % test code         end         function testOne(testCase) % Test fails     end end</pre>



# matlab.unittest.plugins.FailureDiagnosticsPlugin

---

```
 testCase.verifyEqual(5, 4, 'Testing 5==4');
 end
 function testTwo(testCase) % Test passes
 testCase.verifyEqual(5, 5, 'Testing 5==5');
 end
end
end
end
```

The `verifyEqual` qualification in `testOne` causes a test failure. The qualifications in `testOne` and `testTwo` include an instance of a `matlab.unittest.diagnostics.StringDiagnostic`.

At the command prompt, create a test suite from the `ExampleTest` class.

```
import matlab.unittest.TestRunner;
import matlab.unittest.TestSuite;
import matlab.unittest.plugins.FailureDiagnosticsPlugin;

suite = TestSuite.fromClass(?ExampleTest);
```

Create a test runner with no plugins. This code creates a silent runner and provides you with complete control over the installed plugins.

```
runner = TestRunner.withNoPlugins;
```

Run the tests.

```
result1 = runner.run(suite);
```

No output is displayed, but `result1` contains information about the failed test.

Add `FailureDiagnosticsPlugin` to the runner and run the tests.

```
runner.addPlugin(FailureDiagnosticsPlugin);
result2 = runner.run(suite);
```

```
=====
Verification failed in ExampleTest/testOne.
```

# matlab.unittest.plugins.FailureDiagnosticsPlugin

---

```

Test Diagnostic:

Testing 5==4

Framework Diagnostic:

verifyEqual failed.
--> The values are not equal using "isequaln".

Actual Value:
 5
Expected Value:
 4
```

```

Stack Information:

In C:\work\ExampleTest.m (ExampleTest.testOne) at 7
```

=====  
Failure Summary:

Name	Failed	Incomplete	Reason(s)
ExampleTest/testOne	X		Failed by verification.

The framework displays the `DiagnosticResult` of the `StringDiagnostic` for failed tests only. It also displays additional framework diagnostics. The `TestResult` object, `result2`, is the same as `result1`.

## See Also

[matlab.unittest.diagnostics](#) | [matlab.unittest.plugins](#) | [OutputStream](#) | [ToStandardOutput](#)

## Concepts

## Purpose

Interface that determines where to send text output

## Description

The OutputStream interface is an abstract interface class that you can use as a base class to specify where plugins direct their text output. To create a custom output stream, implement a `print` method that correctly handles the formatted text information the testing framework passes to it. Many text-oriented plugins accept an OutputStream to redirect the text they produce in a configurable manner.

## Methods

`print` Print string to output stream

## Copy Semantics

Handle. To learn how handle classes affect copy operations, see Copying Objects in the MATLAB documentation.

## Examples

### Create Custom Output Stream

In a file in your working directory, create a new output stream class in the file `ToFigure.m`. This class allows plugin output to be redirected to a figure.

```
classdef ToFigure < matlab.unittest.plugins.OutputStream

 properties(SetAccess=private)
 Figure
 end
 properties(Dependent, Access=private)
 CurrentText
 end
 properties(Access=private)
 ListBox
 end
```

This class uses three properties. `Figure` is the figure that receives and displays the output. `CurrentText` is the current text displayed in the list box and a dependent property that you can use to easily access

# matlab.unittest.plugins.OutputStream

---

and set the current text in the list box. `ListBox` is a handle to the list box that displays the text.

In the same file, add the following methods block.

```
methods
 function print(stream, formatSpec, varargin)
 if isempty(stream.Figure) || ~ishghandle(stream.Figure)
 stream.createFigure;
 end
 newStr = sprintf(formatSpec, varargin{:});
 str = sprintf('%s%s', stream.CurrentText, newStr);
 stream.CurrentText = str;
 end

 function str = get.CurrentText(stream)
 strCell = cellstr(get(stream.ListBox, 'String'));
 str = strjoin(strCell, '\n');
 end

 function set.CurrentText(stream, str)
 strCell = strsplit(str, '\n');
 set(stream.ListBox, 'String', strCell, 'ListBoxTop', numel(str));
 drawnow;
 end
end
```

You must implement the `print` method for any subclass of `OutputStream`. In this example, the method creates a new figure (if necessary), formats the incoming text, and then adds it to the output stream. The `get.CurrentText` function gets the text from the list box on the figure. The `set.CurrentText` function adds the text onto the list box on the figure.

In the same file, add the following methods block containing a helper function to create the figure.

```
methods(Access=private)
```

```
function createFigure(stream)
 stream.Figure = figure;
 stream.ListBox = uicontrol(...
 'Parent', stream.Figure, ...
 'Style', 'listbox', ...
 'Units', 'normalized', ...
 'Position', [.05 .05 .9 .9], ...
 'Max', 2, ...
 'FontSize', 13, ...
 'HorizontalAlignment', 'left');
 end
end
end
```

In a new file in your working folder, create `ExampleTest.m` containing the following test class.

```
classdef ExampleTest < matlab.unittest.TestCase
 methods(Test)
 function testOne(testCase) % Test fails
 testCase.verifyEqual(5, 4, 'Testing 5==4');
 end
 function testTwo(testCase) % Test passes
 testCase.verifyEqual(5, 5, 'Testing 5==5');
 end
 function testThree(testCase)
 % test code
 end
 end
end
```

The `verifyEqual` qualification in `testOne` causes a test failure. The qualifications in `testOne` and `testTwo` include an instance of a `matlab.unittest.diagnostics.StringDiagnostic`.

At the command prompt, create a test suite from the `ExampleTest` class.

```
import matlab.unittest.TestSuite;
```

# matlab.unittest.plugins.OutputStream

---

```
import matlab.unittest.TestRunner;
import matlab.unittest.plugins.DiagnosticsValidationPlugin;
```

```
suite = TestSuite.fromClass(?ExampleTest);
```

Create a test runner that displays output to the command window.

```
runner = TestRunner.withTextOutput;
```

Create a `DiagnosticsValidationPlugin` that explicitly specifies that its output should go to a figure via the `ToFigure` output stream.

```
plugin = DiagnosticsValidationPlugin(ToFigure);
```

Add the plugin to the `TestRunner` and run the suite.

```
runner.addPlugin(plugin);
result = runner.run(suite);
```

```
Running ExampleTest
```

```
=====
Verification failed in ExampleTest/testOne.
```

```

Test Diagnostic:
```

```

Testing 5==4
```

```

Framework Diagnostic:
```

```

verifyEqual failed.
--> The values are not equal using "isequal".
```

```
Actual Value:
```

```
5
```

```
Expected Value:
```

4

```

Stack Information:

In C:\work\ExampleTest.m (ExampleTest.testOne) at 4
=====
```

...

```
Done ExampleTest
```

---

Failure Summary:

Name	Failed	Incomplete	Reason(s)
ExampleTest/testOne	X		Failed by verification.

Only the test failures produce output to the screen. By default, `TestRunner.withTextOutput` uses a `FailureDiagnosticsPlugin` to display output on the screen.

In addition to the default text output being displayed on the screen, the `DiagnosticsValidationPlugin` output is directed to a figure. The figure shows the following text.

```

Validation of Test Diagnostic:

Testing 5==4

Validation of Test Diagnostic:

Testing 5==5
```

The `DiagnosticsValidationPlugin` displays the diagnostic information regardless of whether the tests encounter failure conditions.

# matlab.unittest.plugins.OutputStream

---

## See Also

[fprintf](#) | [matlab.unittest.plugins.OutputStream](#) |  
[matlab.unittest.plugins](#)

## Concepts



**Purpose**

Print string to output stream

**Syntax**

```
print(stream,formatSpec,A1,...,An)
```

**Description**

`print(stream,formatSpec,A1,...,An)` formats the data in arrays `A1,...,An` according to `formatSpec`, and sends the result to the output stream, `stream`. Assign `formatSpec` and `A1,...,An` using the same interface that you use for `sprintf` and `fprintf`.

**Input Arguments****stream**

Output stream, specified as an instance of the `OutputStream` class

**formatSpec**

Format of text in output stream, specified as a string. For information on the construction of `formatSpec` string, see the input argument entry on the `fprintf` or `sprint` reference pages.

**A**

Numeric or character arrays, specified as a scalar, vector, matrix, or multidimensional array.

**See Also**

`fprintf` | `sprintf`

# matlab.unittest.plugins.StopOnFailuresPlugin

---

**Purpose** Plugin to debug test failures

**Description** The `StopOnFailuresPlugin` class provides a plugin to help debug test failures. Adding `StopOnFailuresPlugin` to the test runner pauses execution of a test if it encounters a qualification failure or uncaught error and puts MATLAB into debug mode.

If `StopOnFailuresPlugin` encounters a qualification failure or uncaught error in a test, you can use MATLAB debugging commands, such as `dbup`, `dbstep`, `dbcont`, and `dbquit`, to investigate the cause of the test failure.

If `StopOnFailuresPlugin` encounters an uncaught error in a test, you cannot use `dbup` to shift context to the source of the error because the error disrupts the stack.

**Construction** `matlab.unittest.plugins.StopOnFailuresPlugin` creates a plugin to debug test failures.

`matlab.unittest.plugins.StopOnFailuresPlugin('IncludingAssumptionFailures',tf)` indicates whether to react to assumption failures. By default, `StopOnFailuresPlugin` reacts to only uncaught errors and verification, assertion, and fatal assertion qualification errors. However, when `'IncludingAssumptionFailures'` is set to `true`, the plugin also reacts to assumption failures.

## Input Arguments

### **tf** - Indicator to react to assumption failures

FALSE (default) | TRUE

Indicator to react to assumption failures, specified as logical `false` or `true`. When this value is `true`, the test runner reacts to assumption failures. When the value is `false`, the plugin ignores assumption failures.

## Properties

### IncludeAssumptionFailures

When this property value is `true`, the instance reacts to assumption failures. When the value is `false`, the instance ignores assumption failures. The `IncludeAssumptionFailures` property is `false` by default. To specify the property as `true`, use the `IncludingAssumptionFailures` input when you construct the instance.

## Copy Semantics

Handle. To learn how handle classes affect copy operations, see [Copying Objects](#) in the MATLAB documentation.

## Examples

### Add Plugin to TestRunner

In your working folder, create the file `ExampleTest.m` containing the following test class.

```
classdef ExampleTest < matlab.unittest.TestCase
 methods(Test)
 function testOne(testCase) % Test fails
 act = 3.1416;
 exp = pi;
 testCase.verifyEqual(act, exp);
 end
 function testTwo(testCase) % Test does not complete
 testCase.assumeEqual(5, 4);
 end
 end
end
```

At the command prompt, create a test suite from the `ExampleTest` class and a test runner.

```
import matlab.unittest.TestRunner;
import matlab.unittest.TestSuite;
import matlab.unittest.plugins.StopOnFailuresPlugin;

suite = TestSuite.fromClass(?ExampleTest);
```

# matlab.unittest.plugins.StopOnFailuresPlugin

---

```
runner = TestRunner.withTextOutput;
```

Run the tests.

```
result = runner.run(suite);
```

```
=====
Verification failed in ExampleTest/testOne.
```

```

Framework Diagnostic:

verifyEqual failed.
--> The values are not equal using "isequaln".
```

```
Actual Value:
 3.141600000000000
Expected Value:
 3.141592653589793
```

```

Stack Information:

In C:\work\ExampleTest.m (ExampleTest.testOne) at 6
```

```
=====
.
=====
ExampleTest/testTwo was filtered.
```

```
Details
```

```
=====
.
Done ExampleTest
```

```

Failure Summary:
```

Name	Failed	Incomplete	Reason(s)
------	--------	------------	-----------

# matlab.unittest.plugins.StopOnFailuresPlugin

---

```
=====
ExampleTest/testOne X Failed by verification

ExampleTest/testTwo X Filtered by assumption
=====
```

As a result of the qualifications in the test class, the first test fails, and the second test does not complete.

Add the `StopOnFailuresPlugin` to the runner and run the tests.

```
runner.addPlugin(StopOnFailuresPlugin);
result = runner.run(suite);
```

```
=====
Verification failed in ExampleTest/testOne.

Framework Diagnostic:

verifyEqual failed.
--> NumericComparator failed.
 --> The values are not equal using "isequaln".

Actual Value:
 3.141600000000000
Expected Value:
 3.141592653589793

Stack Information:

In C:\work\ExampleTest.m (ExampleTest2.testOne) at 6
=====
Test execution paused due to failure. Either click here or execute DBU
```

During the test execution, when the failure occurs, MATLAB enters debug mode.

# matlab.unittest.plugins.StopOnFailuresPlugin

---

Click on the hyperlinked word 'here' to shift debug context to your work source. If necessary, make the command window your current window.

In workspace belonging to ExampleTest>ExampleTest.testOne at 6

Examine the variables in the workspace.

```
whos
```

Name	Size	Bytes	Class	Attributes
act	1x1	8	double	
exp	1x1	8	double	
testCase	1x1	112	ExampleTest	

Now, you can investigate the cause of the test failure.

For example, see if the test passes when you specify a relative tolerance of  $100*\text{eps}$ .

```
testCase.verifyThat(act, matlab.unittest.constraints.IsEqualTo(exp,...
 'Within', matlab.unittest.constraints.RelativeTolerance(100*eps)));
```

```
=====
Verification failed in ExampleTest/testOne.
```

```

Framework Diagnostic:

```

```
IsEqualTo failed.
```

```
--> NumericComparator failed.
```

```
--> The values are not equal using "isequaln".
```

```
--> RelativeTolerance failed.
```

```
--> The value was not within relative tolerance.
```

```
Tolerance Value:
```

```
2.220446049250313e-14
```

# matlab.unittest.plugins.StopOnFailuresPlugin

---

```
Actual Value:
 3.141600000000000
Expected Value:
 3.141592653589793
```

```

Stack Information:
In C:\work\ExampleTest.m (ExampleTest.testOne) at 6
=====
```

The test fails even with the specified tolerance.

Exit out of debug mode.

```
dbquit
```

```
.
=====
ExampleTest/testTwo was filtered.
 Details
=====
```

```
.
Done ExampleTest
```

Failure Summary:

Name	Failed	Incomplete	Reason(s)
ExampleTest/testOne	X		Failed by verification
ExampleTest/testTwo		X	Filtered by assumption

To enter debug mode for tests that fail by assumption, such as `testTwo` in the `ExampleTest` class, include `'IncludingAssumptionFailures'` option for the plugin.

# matlab.unittest.plugins.StopOnFailuresPlugin

---

```
runner = TestRunner.withTextOutput;
runner.addPlugin(StopOnFailuresPlugin(...
 'IncludingAssumptionFailures', true));
```

If you run the test runner, you enter debug mode for both `testOne` and `testTwo`.

## See Also

[dbup](#) | [dbstep](#) | [dbcont](#) | [dbquit](#) | [matlab.unittest.plugins](#)

## Concepts



<b>Purpose</b>	Plugin that produces Test Anything Protocol stream
<b>Description</b>	The TAPPlugin creates a plugin that produces a Test Anything Protocol (TAP) stream. Using this plugin, you can integrate MATLAB Unit Test results into third-party systems that recognize the TAP protocol. For example, you can integrate test results with continuous integration systems like Jenkins™ or TeamCity®.
<b>Construction</b>	<p><code>matlab.unittest.plugins.TAPPlugin.producingOriginalFormat</code> creates a plugin that produces output in the form of the original TAP format (version 12). By default, the plugin displays the output to the screen. In this case, other output sent to the screen can invalidate the TAP stream. To avoid this, redirect the output to a different output stream, such as the <code>ToFile</code> stream.</p> <p><code>matlab.unittest.plugins.TAPPlugin.producingOriginalFormat(stream)</code> redirects all the text output to the output stream, <code>stream</code>. If you do not specify the output stream, the plugin uses the <code>ToStandardOutput</code> stream.</p> <p><b>Input Arguments</b></p> <p><b>stream</b></p> <p>Location where the plugin directs text output, specified as an <code>OutputStream</code>.</p> <p><b>Default:</b> <code>ToStandardOutput</code></p>
<b>Copy Semantics</b>	Handle. To learn how handle classes affect copy operations, see <a href="#">Copying Objects</a> in the MATLAB documentation.
<b>Examples</b>	<p><b>Create TAP Plugin</b></p> <p>In a new file in your working folder, create <code>ExampleTest.m</code> containing the following test class.</p> <pre>classdef ExampleTest &lt; matlab.unittest.TestCase</pre>

# matlab.unittest.plugins.TAPPlugin

---

```
 methods(Test)
 function testOne(testCase) % Test fails
 testCase.verifyEqual(5, 4, 'Testing 5==4');
 end
 function testTwo(testCase) % Test passes
 testCase.verifyEqual(5, 5, 'Testing 5==5');
 end
 function testThree(testCase)
 % test code
 end
 end
 end
end
```

At the command prompt, create a test suite from the `ExampleTest` class.

```
import matlab.unittest.TestRunner;
import matlab.unittest.TestSuite;
import matlab.unittest.plugins.TAPPlugin;
import matlab.unittest.plugins.ToFile;

suite = TestSuite.fromClass(?ExampleTest);
```

Create a test runner that displays output to the command window using the default plugin.

```
runner = TestRunner.withTextOutput;
```

Create a `TAPPlugin` that explicitly specifies that its output should go to the file `MyTapOutput.tap`.

```
tapFile = 'MyTAPOutput.tap';
plugin = TAPPlugin.producingOriginalFormat(ToFile(tapFile));
```

Add the plugin to the `TestRunner` and run the suite.

```
runner.addPlugin(plugin);
result = runner.run(suite);
```

Running ExampleTest

=====  
Verification failed in ExampleTest/testOne.

-----  
Test Diagnostic:

-----  
Testing 5==4

-----  
Framework Diagnostic:

-----  
verifyEqual failed.

--> The values are not equal using "isequaln".

Actual Value:

5

Expected Value:

4

-----  
Stack Information:

-----  
In C:\work\ExampleTest.m (ExampleTest.testOne) at 4

=====  
...  
Done ExampleTest

-----  
Failure Summary:

Name	Failed	Incomplete	Reason(s)
ExampleTest/testOne	X		Failed by verification.

Observe contents in the file created by the plugin.

# matlab.unittest.plugins.TAPPlugin

---

```
disp(fileread(tapFile));
```

```
1..3
not ok 1 - ExampleTest/testOne
ok 2 - ExampleTest/testTwo
ok 3 - ExampleTest/testThree
```

You can use the TAPPlugin directed to standard output. However, any other text displayed to standard output (such as failed test information) interrupts the stream and has the potential to invalidate it.

## See Also

```
matlab.unittest.plugins.TestRunnerPlugin
| matlab.unittest.plugins.ToFile |
matlab.unittest.plugins.OutputStream
```

## Concepts

## External Web Sites

- [Jenkins](#)
- [TeamCity](#)
- [testanything.org](#)

**Superclasses**    `OutputStream`

**Purpose**    `Output stream to write text output to file`

**Description**    `The ToFile class creates an output stream that writes text output to a file. Whenever text prints to this stream, the output stream opens the file, appends the text, and closes the file.`

**Construction**    `matlab.unittest.plugins.ToFile(fname)` creates an `OutputStream` that writes text output to the file, `fname`.

### **Input Arguments**

#### **fname**

`Name of file to write the output text, specified as a string. If fname exists, the text from the stream is appended to the file.`

### **Properties**

#### **Filename**

`Name of file to redirect text output from the plugin, specified in the input argument, fname.`

### **Copy Semantics**

`Handle. To learn how handle classes affect copy operations, see Copying Objects in the MATLAB documentation.`

### **Examples**

#### **Direct TAPPlugin Output Text to Separate File**

`In your working folder, create the file ExampleTest.m containing the following test class.`

```
classdef ExampleTest < matlab.unittest.TestCase
 methods(Test)
 function testOne(testCase) % Test fails
 testCase.verifyEqual(5, 4, 'Testing 5==4');
 end
 function testTwo(testCase) % Test passes
 testCase.verifyEqual(5, 5, 'Testing 5==5');
 end
 end
end
```

## matlab.unittest.plugins.ToFile

---

```
 end
 function testThree(testCase)
 % test code
 end
 end
end
```

The `verifyEqual` qualification in `testOne` causes a test failure. The qualifications in `testOne` and `testTwo` include an instance of a `matlab.unittest.diagnostics.StringDiagnostic`.

At the command prompt, create a test suite from the `ExampleTest` class.

```
import matlab.unittest.TestRunner;
import matlab.unittest.TestSuite;
import matlab.unittest.plugins.TAPPlugin;
import matlab.unittest.plugins.ToFile;
```

```
suite = TestSuite.fromClass(?ExampleTest);
```

Create a test runner that displays output to the command window.

```
runner = TestRunner.withTextOutput;
```

Create a `TAPPlugin` that explicitly specifies that its output should go to the file, `MyTapOutput.tap`.

```
filename = 'MyTapOutput.tap';
plugin = TAPPlugin.producingOriginalFormat(ToFile(filename));
```

Add the plugin to the `TestRunner` and run the suite.

```
runner.addPlugin(plugin);
result = runner.run(suite);
```

```
Running ExampleTest
```

```
=====
Verification failed in ExampleTest/testOne.
```

```

Test Diagnostic:

Testing 5==4

Framework Diagnostic:

verifyEqual failed.
--> The values are not equal using "isequaln".

Actual Value:
 5
Expected Value:
 4

Stack Information:

In C:\work\ExampleTest.m (ExampleTest.testOne) at 4
=====
...
Done ExampleTest

Failure Summary:

 Name Failed Incomplete Reason(s)
=====
ExampleTest/testOne X Failed by verification.
```

Only the test failures produce output to the screen. By default, `TestRunner.withTextOutput` uses a `FailureDiagnosticsPlugin` to display output on the screen.

Observe contents in the file created by the plugin.

# matlab.unittest.plugins.ToFile

---

```
disp(fileread(filename));
```

```
1..3
not ok 1 - ExampleTest/testOne
ok 2 - ExampleTest/testTwo
ok 3 - ExampleTest/testThree
```

## See Also

[fopen](#) | [fprintf](#) | [matlab.unittest.plugins.OutputStream](#) | [matlab.unittest.plugins](#)

## Concepts



<b>Superclasses</b>	OutputStream
<b>Purpose</b>	Output stream to display text information to screen
<b>Description</b>	The ToStandardOutput class creates an output stream to display text output to the screen. Many plugins that accept an output stream use ToStandardOutput as their default stream.
<b>Construction</b>	matlab.unittest.plugins.ToStandardOutput creates an OutputStream that prints text output to the screen.
<b>Copy Semantics</b>	Handle. To learn how handle classes affect copy operations, see Copying Objects in the MATLAB documentation.

## Examples

### Direct Plugin Output Text to Standard Output

In your working folder, create the file ExampleTest.m containing the following test class.

```
classdef ExampleTest < matlab.unittest.TestCase
 methods(Test)
 function testOne(testCase) % Test fails
 testCase.verifyEqual(5, 4, 'Testing 5==4');
 end
 function testTwo(testCase) % Test passes
 testCase.verifyEqual(5, 5, 'Testing 5==5');
 end
 function testThree(testCase)
 % test code
 end
 end
end
```

The `verifyEqual` qualification in `testOne` causes a test failure. The qualifications in `testOne` and `testTwo` include an instance of a `matlab.unittest.diagnostics.StringDiagnostic`.

# matlab.unittest.plugins.ToStandardOutput

---

At the command prompt, create a test suite from the `ExampleTest` class.

```
import matlab.unittest.TestRunner;
import matlab.unittest.TestSuite;
import matlab.unittest.plugins.FailureDiagnosticsPlugin;
import matlab.unittest.plugins.ToStandardOutput;
```

```
suite = TestSuite.fromClass(?ExampleTest);
```

Create a test runner with no plugins. This code creates a silent runner and provides you with complete control over the installed plugins.

```
runner = TestRunner.withNoPlugins;
```

Create a `FailureDiagnosticsPlugin` that explicitly specifies that its output should go to the screen.

```
plugin = FailureDiagnosticsPlugin(ToStandardOutput);
```

Add the plugin to the `TestRunner` and run the suite.

```
runner.addPlugin(plugin);
result = runner.run(suite);
```

```
=====
Verification failed in ExampleTest/testOne.
```

```

Test Diagnostic:
```

```

Testing 5==4
```

```

Framework Diagnostic:
```

```

verifyEqual failed.
--> The values are not equal using "isequaln".
```

```
Actual Value:
```

# matlab.unittest.plugins.ToStandardOutput

---

```
5
Expected Value:
4

Stack Information:

In C:\work\ExampleTest.m (ExampleTest.testOne) at 4
=====
Failure Summary:

Name Failed Incomplete Reason(s)

ExampleTest/testOne X Failed by verification.
```

Only the test failures produce output to the screen.

## See Also

[fprintf](#) | [matlab.unittest.plugins.OutputStream](#) |  
[matlab.unittest.plugins](#)

## Concepts

# matlab.unittest.plugins.TestRunnerPlugin

---

**Purpose** Plugin interface for extending TestRunner

**Description** The TestRunnerPlugin interface enables extension of the matlab.unittest.TestRunner. To customize a test run, create a subclass of TestRunnerPlugin and override select methods. TestRunnerPlugin provides you with a default implementation, so override only methods necessary to achieve your required customization. Every method you implement must invoke its corresponding superclass method, passing along the same instance of pluginData that it receives.

To run tests with this extension, add the custom TestRunnerPlugin to the TestRunner using the addPlugin method of TestRunner.

## Methods

createSharedTestFixture	Extend creation of shared test fixture instances
createTestClassInstance	Extend creation of class-level TestCase instances
createTestMethodInstance	Extend creation of method-level TestCase instances
runTest	Extend running of single TestSuite element
runTestClass	Extend running of TestSuite array from same class or function
runTestMethod	Extend running of single Test method
runTestSuite	Extend running of TestSuite array
setupSharedTestFixture	Extend setting up shared test fixture
setupTestClass	Extend setting up test class
setupTestMethod	Extend setting up of test method

<code>teardownSharedTestFixture</code>	Extend tearing down shared test fixture
<code>teardownTestClass</code>	Extend tearing down of test class
<code>teardownTestMethod</code>	Extend tearing down of test method

## Copy Semantics

Handle. To learn how handle classes affect copy operations, see Copying Objects in the MATLAB documentation.

## See Also

`matlab.unittest.plugins.plugindata.PluginData` |  
`matlab.unittest.plugins.plugindata.TestSuiteRunPluginData` |  
`matlab.unittest.plugins.plugindata.SharedTestFixturePluginData` |  
`matlab.unittest.TestRunner`

## Related Examples

- “Write Plugins to Extend TestRunner”
- “Create Custom Plugin”

## Concepts

# matlab.unittest.plugins.TestRunnerPlugin.runTestSuite

---

**Purpose** Extend running of TestSuite array

**Syntax** runTestSuite(plugin,pluginData)

**Description** runTestSuite(plugin,pluginData) extends the running of the original TestSuite array that the test framework hands to the TestRunner.

## Input Arguments

### plugin

Instance of matlab.unittest.plugins.TestRunnerPlugin.

### pluginData

Test suite information, specified as an instance of matlab.unittest.plugins.pluginData.TestSuiteRunPluginData. The test framework uses this information to introspect into the test content.

## Examples

### Implement runTestSuite Method

```
classdef ExamplePlugin < matlab.unittest.plugins.TestRunnerPlugin
 methods (Access = protected)
 function runTestSuite(plugin, pluginData)

 % Introspect into pluginData to get TestSuite size
 suiteSize = numel(pluginData.TestSuite);
 fprintf('### Running a total of %d tests\n', suiteSize);

 % Invoke the super class method
 runTestSuite@matlab.unittest.plugins.TestRunnerPlugin(plugin,
 end
 end
 end
 end
end
```

## See Also

matlab.unittest.TestRunner |  
matlab.unittest.plugins.pluginData.TestSuiteRunPluginData |  
matlab.unittest.TestResult

# matlab.unittest.plugins.TestRunnerPlugin.runTestSuite

---

## **Related Examples**

- “Write Plugins to Extend TestRunner”
- “Create Custom Plugin”

# matlab.unittest.plugins.TestRunnerPlugin.createSharedTestFixture

**Purpose** Extend creation of shared test fixture instances

**Syntax** `f = createSharedTestFixture(plugin,pluginData)`

**Description** `f = createSharedTestFixture(plugin,pluginData)` extends the creation of shared test fixtures and returns the modified `Fixture` instance, `f`. The testing framework uses the fixture instance to customize running tests that use shared fixtures. The testing framework evaluates this method within the scope of the `runTestSuite` method of the `TestRunnerPlugin` for each shared test fixture it needs to set up. A typical implementation of this method is to add listeners to various events originating from the shared test fixture instance. Since the `Fixture` inherits from the `handle` class, add listeners by calling the `addListener` method from within the `createSharedTestFixture` method.

## Input Arguments

### **plugin**

Instance of `matlab.unittest.plugins.TestRunnerPlugin`.

### **pluginData**

Shared test fixture creation information, specified as an instance of `matlab.unittest.plugins.plugindata.PluginData`. The test framework uses this information to introspect into the test content.

## Examples

### **Extend Creation of Shared Test Fixture Instances**

Extend the running of tests to count the number of shared test fixture assertion failures.

```
classdef ExamplePlugin < matlab.unittest.plugins.TestRunnerPlugin

 properties (SetAccess = private)
 FixtureAssertionFailureData = {};
 end
```



# matlab.unittest.plugins.TestRunnerPlugin.createSharedTest

```
methods (Access = protected)
 function fixture = createSharedTestFixture(plugin, pluginData)
 % Invoke the super class method
 fixture = createSharedTestFixture@...
 matlab.unittest.plugins.TestRunnerPlugin(plugin, pluginData);

 % Get the fixture name
 fixtureName = pluginData.Name;

 % Add a listener to fixture assertion failures
 % and capture the qualification failure information
 fixture.addListener('AssertionFailed', @(~,evd) ...
 plugin.captureFixtureAssertionFailureData(evd, fixtureName));
 end
end

methods (Access = private)
 function captureFixtureAssertionFailureData(plugin, eventData)
 plugin.FixtureAssertionFailureData{end+1} = struct(...
 'FixtureName', fixtureName, ...
 'ActualValue', eventData.ActualValue, ...
 'Constraint' , eventData.Constraint, ...
 'Stack' , eventData.Stack);
 end
end
end
```

## See Also

matlab.unittest.TestRunner | matlab.unittest.fixtures.Fixture  
| matlab.unittest.plugins.pluginData.PluginData |  
matlab.unittest.qualifications.ExceptionEventData |  
matlab.unittest.qualifications.QualificationEventData

## Related Examples

- “Write Plugins to Extend TestRunner”
- “Create Custom Plugin”

# matlab.unittest.plugins.TestRunnerPlugin.setupSharedTestFixture

<b>Purpose</b>	Extend setting up shared test fixture
<b>Syntax</b>	<code>setupSharedTestFixture(plugin,pluginData)</code>
<b>Description</b>	<code>setupSharedTestFixture(plugin,pluginData)</code> extends the setting up of a shared test fixture. This method defines how the <code>TestRunner</code> performs shared fixture setup. The test framework evaluates this method one time for each shared test fixture, within the scope of the <code>runTestSuite</code> method of the <code>TestRunnerPlugin</code> .
<b>Input Arguments</b>	<p><b>plugin</b></p> <p>Instance of <code>matlab.unittest.plugins.TestRunnerPlugin</code>.</p> <p><b>pluginData</b></p> <p>Shared test fixture setup information, specified as an instance of <code>matlab.unittest.plugins.plugindata.SharedTestFixturePluginData</code>. The test framework uses this information to introspect into the test content.</p>
<b>Examples</b>	<p><b>Implement setupSharedTestFixture Method</b></p> <p>Display the shared test fixture name at setup time.</p> <pre>classdef ExamplePlugin &lt; matlab.unittest.plugins.TestRunnerPlugin      methods (Access = protected)         function setupSharedTestFixture(plugin, pluginData)             fprintf('### Setting up: %s\n', pluginData.Name);             setupSharedTestFixture@matlab.unittest.plugins.TestRunnerPlugin                 (plugin, pluginData);         end     end end</pre>

# matlab.unittest.plugins.TestRunnerPlugin.setupSharedTest

---

## See Also

[matlab.unittest.TestRunner](#) |  
[matlab.unittest.plugins.plugindata.SharedTestFixturePluginData](#)  
| [createSharedTestFixture](#)

## Related Examples

- “Write Plugins to Extend TestRunner”
- “Create Custom Plugin”

# matlab.unittest.plugins.TestRunnerPlugin.runTestClass

---

**Purpose** Extend running of TestSuite array from same class or function

**Syntax** runTestClass(plugin,pluginData)

**Description** runTestClass(plugin,pluginData) extends the running of tests that belong to the same test class or the same function-based test. This method applies to a subset of the full TestSuite that the TestRunner. The test framework evaluates this method within the scope of the runTestSuite method of the TestRunnerPlugin. It evaluates this method between setting up and tearing down the shared test fixture (setupSharedTestFixture and teardownSharedTestFixture). Provided the test framework completes shared test fixture setup, it invokes this method one time per test class.

## Input Arguments

### plugin

Instance of matlab.unittest.plugins.TestRunnerPlugin.

### pluginData

Test suite information, specified as an instance of matlab.unittest.plugins.pluginData.TestSuiteRunPluginData. The test framework uses this information to introspect into the test content.

## Examples

### Extend runTestClass method

Print the label of the test content element at run time.

```
classdef ExamplePlugin < matlab.unittest.plugins.TestRunnerPlugin
 methods (Access = protected)
 function runTestClass(plugin, pluginData)
 fprintf('### Running test class: %s\n', pluginData.Name);

 runTestClass@matlab.unittest.plugins.TestRunnerPlugin(...
 plugin, pluginData);
 end
 end
end
```

# matlab.unittest.plugins.TestRunnerPlugin.runTestClass

---

end

## See Also

[matlab.unittest.TestRunner](#) | [matlab.unittest.TestSuite](#) |  
[matlab.unittest.plugins.plugindata.TestSuiteRunPluginData](#)  
| [matlab.unittest.TestResult](#)

## Related Examples

- “Write Plugins to Extend TestRunner”
- “Create Custom Plugin”

# matlab.unittest.plugins.TestRunnerPlugin.createTestClassInstance

**Purpose** Extend creation of class-level `TestCase` instances

**Syntax** `tc = createTestClassInstance(plugin,pluginData)`

**Description** `tc = createTestClassInstance(plugin,pluginData)` extends the creation of class-level `TestCase` instances, and returns the modified `TestCase` instance, `tc`. The test framework uses the `TestCase` instance to customize running tests that belong to the same test class. The test framework evaluates this method within the scope of the `runTestClass` method of the `TestRunnerPlugin`. A typical implementation of this method is to add listeners to various events originating from the class level instance. Since the `TestCase` inherits from the `handle` class, add listeners by calling the `addListener` method from within the `createTestClassInstance` method. For each class, the test framework passes the instance to any method with the `TestClassSetup` or `TestClassTeardown` attribute.

## Input Arguments

### **plugin**

Instance of `matlab.unittest.plugins.TestRunnerPlugin`.

### **pluginData**

Class-level `TestCase` creation information, specified as an instance of `matlab.unittest.plugins.pluginData.PluginData`. The test framework uses this information to introspect into the test content.

## Examples

### **Extend Creation of Class-Level `TestCase` Instances**

Extend the running of tests to count the number of class-level assumption failures.

```
classdef ExamplePlugin < matlab.unittest.plugins.TestRunnerPlugin

 properties (SetAccess = private)
 TestClassAssumptionFailureData = {};
 end
```

# matlab.unittest.plugins.TestRunnerPlugin.createTestClassInstance

```
methods (Access = protected)
 function testCase = createTestClassInstance(plugin, pluginData)
 % Invoke super class method
 testCase = createTestClassInstance@...
 matlab.unittest.plugins.TestRunnerPlugin(plugin, pluginData);

 % Get the test class name
 instanceName = pluginData.Name;

 % Add a listener to capture assumption failures
 testCase.addListener('AssumptionFailed', @(~,evd) ...
 plugin.captureClassLevelAssumptionFailureData(evd, instanceName));
 end
end

methods (Access = private)
 function captureClassLevelAssumptionFailureData(plugin, eventData)
 plugin.TestClassAssumptionFailureData{end+1} = struct(...
 'InstanceName', instanceName, ...
 'ActualValue' , eventData.ActualValue, ...
 'Constraint' , eventData.Constraint, ...
 'Stack' , eventData.Stack);
 end
end
end
```

## See Also

[matlab.unittest.TestRunner](#) | [matlab.unittest.TestCase](#)  
| [matlab.unittest.plugins.pluginData.PluginData](#) |  
[matlab.unittest.qualifications.ExceptionEventData](#) |  
[matlab.unittest.qualifications.QualificationEventData](#)

## Related Examples

- “Write Plugins to Extend TestRunner”
- “Create Custom Plugin”

# matlab.unittest.plugins.TestRunnerPlugin.setupTestClass

<b>Purpose</b>	Extend setting up test class
<b>Syntax</b>	<code>setupTestClass(plugin,pluginData)</code>
<b>Description</b>	<code>setupTestClass(plugin,pluginData)</code> extends the setting up of a test class. This method defines how the <code>TestRunner</code> performs test class setup. The test framework evaluates this method within the scope of the <code>runTestClass</code> method of the <code>TestRunnerPlugin</code> . If the test class contains properties with the <code>ClassSetupParameter</code> attribute, the test framework evaluates the <code>setupTestClass</code> method as many times as the class setup parameterization dictates.

<b>Input Arguments</b>	<b>plugin</b> Instance of <code>matlab.unittest.plugins.TestRunnerPlugin</code> .
	<b>pluginData</b> Test class setup information, specified as an instance of <code>matlab.unittest.plugins.plugindata.PluginData</code> . The test framework uses this information to introspect into the test content.

## Examples **Implement setupTestClass Method**

Display the test class name at setup time.

```
classdef ExamplePlugin < matlab.unittest.plugins.TestRunnerPlugin

 methods (Access = protected)
 function setupTestClass(plugin, pluginData)
 fprintf('### Setting up: %s\n', pluginData.Name);
 setupTestClass@matlab.unittest.plugins.TestRunnerPlugin...
 (plugin, pluginData);
 end
 end
end
```



# matlab.unittest.plugins.TestRunnerPlugin.setupTestClass

---

## See Also

[matlab.unittest.TestRunner](#) |  
[matlab.unittest.plugins.plugindata.PluginData](#) |  
[createClassInstance](#)

## Related Examples

- “Write Plugins to Extend TestRunner”
- “Create Custom Plugin”

# matlab.unittest.plugins.TestRunnerPlugin.runTest

---

**Purpose** Extend running of single TestSuite element

**Syntax** runTest(plugin,pluginData)

**Description** runTest(plugin,pluginData) extends the running of a single TestSuite element. This method allows the test author to override the method that runs a scalar test element in the TestSuite array, including the creation of the TestCase, and the TestMethodSetup and TestMethodTeardown routines. Provided the test framework completes all fixture setup, it invokes this method one time per test element.

## Input Arguments

### plugin

Instance of matlab.unittest.plugins.TestRunnerPlugin.

### pluginData

Test element information, specified as an instance of matlab.unittest.plugins.pluginData.TestSuiteRunPluginData. The test framework uses this information to introspect into the test content.

## Examples

### Extend runTest method

Print the label of the test content element at run time.

```
classdef ExamplePlugin < matlab.unittest.plugins.TestRunnerPlugin
 methods (Access = protected)
 function runTest(plugin, pluginData)
 fprintf('### Running test: %s\n', pluginData.Name);
 runTest@matlab.unittest.plugins.TestRunnerPlugin(...
 plugin, pluginData);
 end
 end
end
```

## See Also

[matlab.unittest.TestRunner](#) |  
[matlab.unittest.plugins.plugindata.TestSuiteRunPluginData](#) |  
[matlab.unittest.TestResult](#)

## Related Examples

- “Write Plugins to Extend TestRunner”
- “Create Custom Plugin”

# matlab.unittest.plugins.TestRunnerPlugin.createTestMethodInst

**Purpose** Extend creation of method-level `TestCase` instances

**Syntax** `tc = createTestMethodInstance(plugin,pluginData)`

**Description** `tc = createTestMethodInstance(plugin,pluginData)` extends the creation of method-level `TestCase` instances, and returns the modified `TestCase` instance, `tc`. The test framework evaluates this method within the scope of the `runTest` method of the `TestRunnerPlugin`. A typical implementation of this method is to add listeners to various events originating from the method level instance. Since the `TestCase` inherits from the `handle` class, add listeners by calling the `addlistener` method from within the `createTestMethodInstance` method. The test framework creates instances for every element of the `matlab.unittest.Test` array and passes each instance to its corresponding `Test` methods and to any method with the `TestMethodSetup` or `TestMethodTeardown` attribute.

## Input Arguments

### **plugin**

Instance of `matlab.unittest.plugins.TestRunnerPlugin`.

### **pluginData**

Method-level `TestCase` creation information, specified as an instance of `matlab.unittest.plugins.pluginData.PluginData`. The test framework uses this information to introspect into the test content.

## Examples

### **Implement createMethodInstance Method**

Add a listener to listen for assumption failures. Use the helper function, `captureMethodLevelAssumptionFailureData`, to populate the `TestMethodAssumptionFailureData` property.

```
classdef ExamplePlugin < matlab.unittest.plugins.TestRunnerPlugin

 properties (SetAccess = private)
 TestMethodAssumptionFailureData = {};
 end
end
```

# matlab.unittest.plugins.TestRunnerPlugin.createTestMethod

```
end

methods (Access = protected)
 function testCase = createTestMethodInstance(plugin, pluginData)
 testCase = createTestMethodInstance@...
 matlab.unittest.plugins.TestRunnerPlugin(plugin, pluginData)

 instanceName = pluginData.Name;
 testCase.addListener('AssumptionFailed', @(~,evd) ...
 plugin.captureMethodLevelAssumptionFailureData(evd, instanceName));
 end
end

methods (Access = private)
 function captureMethodLevelAssumptionFailureData(...
 plugin, eventData, instanceName)
 plugin.TestMethodAssumptionFailureData{end+1} = struct(...
 'InstanceName', instanceName, ...
 'ActualValue' , eventData.ActualValue, ...
 'Constraint' , eventData.Constraint, ...
 'Stack' , eventData.Stack);
 end
end

end
```

## See Also

[matlab.unittest.TestRunner](#) | [matlab.unittest.TestCase](#) |  
[matlab.unittest.plugins.pluginData.PluginData](#) |  
[matlab.unittest.plugins.TestRunnerPlugin.createTestClassInstance](#)  
| [matlab.unittest.qualifications.ExceptionEventData](#) |  
[matlab.unittest.qualifications.QualificationEventData](#)

## Related Examples

- “Write Plugins to Extend TestRunner”
- “Create Custom Plugin”

# matlab.unittest.plugins.TestRunnerPlugin.setupTestMethod

**Purpose** Extend setting up of test method

**Syntax** `setupTestMethod(plugin,pluginData)`

**Description** `setupTestMethod(plugin,pluginData)` extends the setting up of a test method. This method defines how the `TestRunner` performs test method setup for the single test suite element. The test framework evaluates this method within the scope of the `runTest` method of the `TestRunnerPlugin`.

**Input Arguments**

**plugin**  
Instance of `matlab.unittest.plugins.TestRunnerPlugin`.

**pluginData**  
Test method setup information, specified as an instance of `matlab.unittest.plugins.plugindata.PluginData`. The test framework uses this information to introspect into the test content.

## Examples **Implement setupTestMethod**

```
classdef ExamplePlugin < matlab.unittest.plugins.TestRunnerPlugin

 methods (Access = protected)
 function setupTestMethod(plugin, pluginData)
 fprintf('### Setting up: %s\n', pluginData.Name);
 setupTestMethod@matlab.unittest.plugins.TestRunnerPlugin...
 (plugin, pluginData);
 end
 end
end
```

**See Also** `matlab.unittest.TestRunner` | `matlab.unittest.plugins.plugindata.PluginData`

## **Related Examples**

- “Write Plugins to Extend TestRunner”
- “Create Custom Plugin”

# matlab.unittest.plugins.TestRunnerPlugin.runTestMethod

---

<b>Purpose</b>	Extend running of single Test method
<b>Syntax</b>	<code>runTestMethod(plugin,pluginData)</code>
<b>Description</b>	<code>runTestMethod(plugin,pluginData)</code> extends the running of a single Test method. The test framework evaluates this method within the scope of the <code>runTest</code> method of the <code>TestRunnerPlugin</code> . It evaluates this method between setting up and tearing down the scalar <code>TestSuite</code> element ( <code>setUpTestMethod</code> and <code>tearDownTestMethod</code> ).

## Input Arguments

### **plugin**

Instance of `matlab.unittest.plugins.TestRunnerPlugin`.

### **pluginData**

Test method information, specified as an instance of `matlab.unittest.plugins.pluginData.TestSuiteRunPluginData`. The test framework uses this information to introspect into the test content.

## Examples

### **Extend runTestMethod method**

Print the time taken to evaluate the test method.

```
classdef ExamplePlugin < matlab.unittest.plugins.TestRunnerPlugin
 methods (Access = protected)
 function runTestMethod(plugin, pluginData)
 tic;

 runTestMethod@matlab.unittest.plugins.TestRunnerPlugin(...
 plugin, pluginData);

 fprintf('### %s ran in %f seconds excluding fixture time.',...
 pluginData.Name, toc)
 end
 end
end
```



# matlab.unittest.plugins.TestRunnerPlugin.runTestMethod

---

## See Also

matlab.unittest.TestRunner |  
matlab.unittest.plugins.plugindata.TestSuiteRunPluginData  
| matlab.unittest.TestResult |  
matlab.unittest.plugins.TestRunnerPlugin.runTest |  
matlab.unittest.plugins.TestRunnerPlugin.runTestClass

## Related Examples

- “Write Plugins to Extend TestRunner”
- “Create Custom Plugin”

# matlab.unittest.plugins.TestRunnerPlugin.tearDownTestMethod

**Purpose** Extend tearing down of test method

**Syntax** `tearDownTestMethod(plugin,pluginData)`

**Description** `tearDownTestMethod(plugin,pluginData)` extends the tearing down of a test method. This method defines how the `TestRunner` performs test method teardown for the single test suite element. The test framework evaluates this method within the scope of the `runTest` method of the `TestRunnerPlugin`.

**Input Arguments**

**plugin**  
Instance of `matlab.unittest.plugins.TestRunnerPlugin`.

**pluginData**  
Test method teardown information, specified as an instance of `matlab.unittest.plugins.plugindata.PluginData`. The test framework uses this information to introspect into the test content.

## Examples **Implement tearDownTestMethod Method**

Display the test method name at teardown time.

```
classdef ExamplePlugin < matlab.unittest.plugins.TestRunnerPlugin
 methods (Access = protected)
 function tearDownTestMethod(plugin, pluginData)
 fprintf('### Tearing down: %s\n', pluginData.Name);
 tearDownTestMethod@matlab.unittest.plugins.TestRunnerPlugin.
 (plugin, pluginData);
 end
 end
end
```

**See Also** `matlab.unittest.TestRunner` | `matlab.unittest.plugins.plugindata.PluginData` | `matlab.unittest.plugins.TestRunnerPlugin.setupTestMethod`

## **Related Examples**

- “Write Plugins to Extend TestRunner”
- “Create Custom Plugin”

# matlab.unittest.plugins.TestRunnerPlugin.tearDownTestClass

**Purpose** Extend tearing down of test class

**Syntax** `tearDownTestClass(plugin,pluginData)`

**Description** `tearDownTestClass(plugin,pluginData)` extends the tearing down of a test class. This method defines how the `TestRunner` performs test class teardown. The test framework evaluates this method within the scope of the `runTestClass` method of the `TestRunnerPlugin`. If the test class contains properties with the `ClassSetupParameter` attribute, the test framework evaluates the `tearDownTestClass` method as many times as the class setup parameterization dictates.

## Input Arguments

### **plugin**

Instance of `matlab.unittest.plugins.TestRunnerPlugin`.

### **pluginData**

Test class teardown information, specified as an instance of `matlab.unittest.plugins.pluginData.PluginData`. The test framework uses this information to introspect into the test content.

## Examples

### **Implement tearDownTestClass Method**

Display the test class name at teardown time.

```
classdef ExamplePlugin < matlab.unittest.plugins.TestRunnerPlugin

 methods (Access = protected)
 function tearDownTestClass(plugin, pluginData)
 fprintf('### Tearing down: %s\n', pluginData.Name);
 steardownTestClass@matlab.unittest.plugins.TestRunnerPlugin.
 (plugin, pluginData);
 end
 end
end
```

# matlab.unittest.plugins.TestRunnerPlugin.teardownTestClass

---

## See Also

[matlab.unittest.TestRunner](#) |  
[matlab.unittest.plugins.plugindata.PluginData](#) |  
[createClassInstance](#)

## Related Examples

- “Write Plugins to Extend TestRunner”
- “Create Custom Plugin”

# matlab.unittest.plugins.TestRunnerPlugin.tearDownSharedTestF

**Purpose** Extend tearing down shared test fixture

**Syntax** `tearDownSharedTestFixture(plugin,pluginData)`

**Description** `tearDownSharedTestFixture(plugin,pluginData)` extends the tearing down of a shared test fixture. This method defines how the TestRunner performs shared fixture teardown. The test framework evaluates this method one time for each shared test fixture, within the scope of the `runTestSuite` method of the TestRunnerPlugin.

## Input Arguments

### **plugin**

Instance of `matlab.unittest.plugins.TestRunnerPlugin`.

### **pluginData**

Shared test fixture teardown information, specified as an instance of `matlab.unittest.plugins.pluginData.SharedTestFixturePluginData`. The test framework uses this information to introspect into the test content.

## Examples

### **Implement tearDownSharedTestFixture Method**

Display the shared test fixture name at teardown time.

```
classdef ExamplePlugin < matlab.unittest.plugins.TestRunnerPlugin

 methods (Access = protected)
 function tearDownSharedTestFixture(plugin, pluginData)
 fprintf('### Setting up: %s\n', pluginData.Name);
 tearDownSharedTestFixturer@matlab.unittest.plugins.TestRunner
 (plugin, pluginData);
 end
 end
end
```

## See Also

[matlab.unittest.TestRunner](#) |  
[matlab.unittest.plugins.plugindata.SharedTestFixturePluginData](#)  
| [createSharedTestFixture](#)

## Related Examples

- “Write Plugins to Extend TestRunner”
- “Create Custom Plugin”

# matlab.unittest.plugins.TestSuiteProgressPlugin

---

<b>Purpose</b>	Plugin that outputs progress information as text
<b>Description</b>	The <code>TestSuiteProgressPlugin</code> class creates a plugin to output progress information as text. <code>TestSuiteProgressPlugin</code> is added to the <code>TestRunner</code> to show the progress of the testing to the Command Window. This plugin is used by default when you construct a test runner with <code>TestRunner.withTextOutput</code> .
<b>Construction</b>	<code>matlab.unittest.plugins.TestSuiteProgressPlugin</code> creates a plugin to output progress information as text.  <code>matlab.unittest.plugins.TestSuiteProgressPlugin(stream)</code> redirects all the text output to the output stream, <code>stream</code> . If you do not specify the output stream, the plugin uses the <code>ToStandardOutput</code> stream.
<b>Input Arguments</b>	<b>stream</b>  Location where the plugin directs text output, specified as an <code>OutputStream</code> .  <b>Default:</b> <code>ToStandardOutput</code>
<b>Copy Semantics</b>	Handle. To learn how handle classes affect copy operations, see <a href="#">Copying Objects</a> in the MATLAB documentation.
<b>Examples</b>	<b>Add Plugin to TestRunner</b>  In your working folder, create the file <code>ExampleTest.m</code> containing the following test class.  <pre>classdef ExampleTest &lt; matlab.unittest.TestCase     methods(Test)         function testOne(testCase)             % test code         end         function testTwo(testCase) % Test fails     end end</pre>



# matlab.unittest.plugins.TestSuiteProgressPlugin

---

```
 % test code
 end
 function testThree(testCase) % Test passes
 % test code
 end
end
end
end
```

At the command prompt, create a test suite from the `ExampleTest` class.

```
import matlab.unittest.TestRunner;
import matlab.unittest.TestSuite;
import matlab.unittest.plugins.TestSuiteProgressPlugin;

suite = TestSuite.fromClass(?ExampleTest);
```

Create a test runner with no plugins. This code creates a silent runner and provides you with complete control over the installed plugins.

```
runner = TestRunner.withNoPlugins;
```

Run the tests.

```
result1 = runner.run(suite);
```

No output is displayed.

Add `TestSuiteProgressPlugin` to the runner and run the tests.

```
runner.addPlugin(TestSuiteProgressPlugin);
result2 = runner.run(suite);
```

```
Running ExampleTest
...
Done ExampleTest
```

---

## See Also

[matlab.unittest.plugins](#) | [OutputStream](#) | [ToStandardOutput](#)

## Concepts

## Purpose

Summary of classes in MATLAB Plugin Data Interface

## Description

The `plugindata` classes store information about test content for use by the plugins and plugin methods. The `TestRunner` passes instances of these classes to various plugin methods. The `matlab.unittest.plugins.plugindata` package consists of the following MATLAB plugin data classes.

`matlab.unittest.plugins.plugindata.PluginData` passed to `TestRunnerPlugin` methods

`matlab.unittest.plugins.plugindata.PluginTestFixtureData` test fixture information

`matlab.unittest.plugins.plugindata.PluginSelectedTestInfo` selected test information

## See Also

`TestRunnerPlugin` | `matlab.unittest.plugins`

# matlab.unittest.plugins.plugindata.PluginData

---

**Purpose** Data object passed to TestRunnerPlugin methods

**Description** The PluginData class defines the data the TestRunner passes to various plugin methods. It is created by the TestRunner, so there is no need for test plugin authors to construct this class directly.

**Properties**

Name
Label of test content executed by the test runner within the scope of a plugin method, represented as a string. Use the Name property for informational, labeling, and display purposes. Do not use Nameprogrammatically to introspect into the content.

**See Also** TestRunnerPlugin

**Concepts**

# matlab.unittest.plugins.plugindata.SharedTestFixturePlug

---

**Purpose** Plugin data containing shared test fixture information

**Description** The SharedTestFixturePluginData defines the data the TestRunner passes to plugin methods related to shared test fixtures. The TestRunner creates this, so there is no need for test plugin authors to construct this class directly.

**Properties**

**Name**

Label of shared test fixture, represented as a string. Use the Name property for informational, labeling, and display purposes. Do not use Nameprogrammatically to introspect into the content.

**Description**

Description of action performed during setup and teardown of a shared text fixture, represented as a string

**See Also** TestRunnerPlugin | matlab.unittest.fixtures.Fixture

**Concepts**

# matlab.unittest.plugins.plugindata.TestSuiteRunPluginData

---

**Purpose** Plugin data containing selected test information

**Description** The `TestSuiteRunPluginData` defines the data the `TestRunner` passes to plugin methods related to running tests from the suite. The `TestRunner` creates this, so there is no need for test plugin authors to construct this class directly.

**Properties**

Name
Name corresponding to the portion of the test suite the runner executes within a plugin method, represented as a string. Use the <code>Name</code> property for informational, labeling, and display purposes. Do not use <code>Name</code> programmatically to introspect into the content.

**TestSuite**

Select test methods, represented as a `matlab.unittest.TestSuite` instance

**TestResult**

Results from running select test methods listed in `TestSuite`, represented as a `matlab.unittest.TestResult` array

**See Also** `TestRunnerPlugin` | `matlab.unittest.TestSuite` | `matlab.unittest.TestResult`

**Concepts**

<b>Purpose</b>	Addition
<b>Syntax</b>	$C = A + B$ <code>C = plus(A,B)</code>
<b>Description</b>	<p><math>C = A + B</math> adds arrays A and B and returns the result in C.</p> <p><math>C = \text{plus}(A,B)</math> is an alternate way to execute <math>A + B</math>, but is rarely used. It enables operator overloading for classes.</p>
<b>Input Arguments</b>	<p><b>A - Input array</b> scalar   vector   matrix   multidimensional array</p> <p>Input array, specified as a scalar, vector, matrix, or multidimensional array. Inputs A and B must be the same size unless one is a scalar. You can add a scalar value to any other value.</p> <p><b>Data Types</b> single   double   int8   int16   int32   int64   uint8   uint16   uint32   uint64   logical   char <b>Complex Number Support:</b> Yes</p> <p><b>B - Input array</b> scalar   vector   matrix   multidimensional array</p> <p>Input array, specified as a scalar, vector, matrix, or multidimensional array. Inputs A and B must be the same size unless one is a scalar. You can add a scalar value to any other value.</p> <p><b>Data Types</b> single   double   int8   int16   int32   int64   uint8   uint16   uint32   uint64   logical   char <b>Complex Number Support:</b> Yes</p>
<b>Examples</b>	<p><b>Add Scalar to Array</b></p> <p>Create an array, A, and add a scalar value to it.</p>

```
A = [0 1; 1 0];
C = A + 2
```

```
C =
```

```
 2 3
 3 2
```

The scalar value is added to each entry of A.

## Add Two Arrays

Create two arrays, A and B, and add them together.

```
A = [1 0; 2 4];
B = [5 9; 2 1];
C = A + B
```

```
C =
```

```
 6 9
 4 5
```

The elements of A are added to the corresponding elements of B.

## See Also

[minus](#) | [sum](#) | [cumsum](#) | [uplus](#)



**Purpose** (Will be removed) Simplex containing specified location

---

**Note** `pointLocation(DelaunayTri)` will be removed in a future release. Use `pointLocation(delaunayTriangulation)` instead.

`DelaunayTri` will be removed in a future release. Use `delaunayTriangulation` instead.

---

**Syntax**

```
SI = pointLocation(DT,QX)
SI = pointLocation(DT,QX,QY)
SI = pointLocation(DT,QX,QY,QZ)
[SI, BC] = pointLocation(DT,...)
```

**Description** `SI = pointLocation(DT,QX)` returns the indices `SI` of the enclosing simplex (triangle/tetrahedron) for each query point location in `QX`. The enclosing simplex for point `QX(k,:)` is `SI(k)`. `pointLocation` returns `NaN` for all points outside the convex hull.

`SI = pointLocation(DT,QX,QY)` and `SI = pointLocation(DT,QX,QY,QZ)` allow the query point locations to be specified in alternative column vector format when working in 2-D and 3-D.

`[SI, BC] = pointLocation(DT,...)` returns the barycentric coordinates `BC`.

**Input Arguments**

<code>DT</code>	Delaunay triangulation.
<code>QX</code>	Matrix of size <code>mpts-by-ndim</code> , <code>mpts</code> being the number of query points.

# DelaunayTri.pointLocation

---

## Output Arguments

SI	Column vector of length <code>mpts</code> containing the indices of the enclosing simplex for each query point. <code>mpts</code> is the number of query points.
BC	BC is a <code>mpts-by-ndim</code> matrix, each row <code>BC(i,:)</code> represents the barycentric coordinates of <code>QX(i,:)</code> with respect to the enclosing simplex <code>SI(i)</code> .

## Examples

### Example 1

Create a 2-D Delaunay triangulation:

```
X = rand(10,2);
dt = DelaunayTri(X);
```

Find the triangles that contain specified query points:

```
qrypts = [0.25 0.25; 0.5 0.5];
triids = pointLocation(dt, qrypts)
```

### Example 2

Create a 3-D Delaunay triangulation:

```
x = rand(10,1);
y = rand(10,1);
z = rand(10,1);
dt = DelaunayTri(x,y,z);
```

Find the triangles that contain specified query points and evaluate the barycentric coordinates:

```
qrypts = [0.25 0.25 0.25; 0.5 0.5 0.5];
[tetids, bcs] = pointLocation(dt, qrypts)
```

## See Also

[nearestNeighbor](#) | [delaunayTriangulation](#) | [triangulation](#)

**Purpose** Transform polar or cylindrical coordinates to Cartesian

**Syntax**  
 $[X,Y] = \text{pol2cart}(\text{THETA},\text{RHO})$   
 $[X,Y,Z] = \text{pol2cart}(\text{THETA},\text{RHO},Z)$

**Description**  $[X,Y] = \text{pol2cart}(\text{THETA},\text{RHO})$  transforms the polar coordinate data stored in corresponding elements of THETA and RHO to two-dimensional Cartesian, or *xy*, coordinates. The arrays THETA and RHO must be the same size (or either can be scalar). The values in THETA must be in radians.

$[X,Y,Z] = \text{pol2cart}(\text{THETA},\text{RHO},Z)$  transforms the cylindrical coordinate data stored in corresponding elements of THETA, RHO, and Z to three-dimensional Cartesian, or *xyz* coordinates. The arrays THETA, RHO, and Z must be the same size (or any can be scalar). The values in THETA must be in radians.

**Algorithms** The mapping from polar and cylindrical coordinates to Cartesian coordinates is:

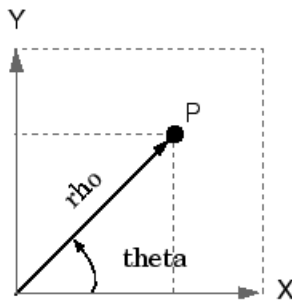

**Polar to Cartesian Mapping**  
 $x = \text{rho} * \cos(\text{theta})$   
 $y = \text{rho} * \sin(\text{theta})$

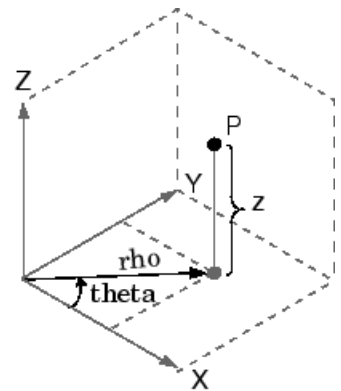

**Polar to Cartesian Mapping**  
 $x = \text{rho} * \cos(\text{theta})$   
 $y = \text{rho} * \sin(\text{theta})$   
 $z = z$

# pol2cart

---

## See Also

[cart2pol](#) | [cart2sph](#) | [sph2cart](#)

**Purpose**

Polar coordinate plot

**Syntax**

```
polar(theta,rho)
polar(theta,rho,LineStyle)
polar(axes_handle,...)
h = polar(...)
```

**Description**

The `polar` function accepts polar coordinates, plots them in a Cartesian plane, and draws the polar grid on the plane.

`polar(theta,rho)` creates a polar coordinate plot of the angle `theta` versus the radius `rho`. `theta` is the angle from the  $x$ -axis to the radius vector specified in radians; `rho` is the length of the radius vector specified in dataspace units.

`polar(theta,rho,LineStyle)` `LineStyle` specifies the line type, plot symbol, and color for the lines drawn in the polar plot.

`polar(axes_handle,...)` plots into the axes with the handle `axes_handle` instead of into the current axes (`gca`).

`h = polar(...)` returns the handle of a line object in `h`.

**Tips**

Negative  $r$  values reflect through the origin, rotating by  $\pi$  (since  $(\theta,r)$  transforms to  $(r\cos(\theta), r\sin(\theta))$ ). If you want different behavior, you can manipulate  $r$  prior to plotting. For example, you can make  $r$  equal to  $\max(0,r)$  or  $\text{abs}(r)$ .

**Examples****Simple Polar Plot**

Create a simple polar plot using a dashed red line.

```
theta = 0:0.01:2*pi;
rho = sin(2*theta).*cos(2*theta);
```

# polar

---

```
figure
polar(theta,rho,'--r')
```

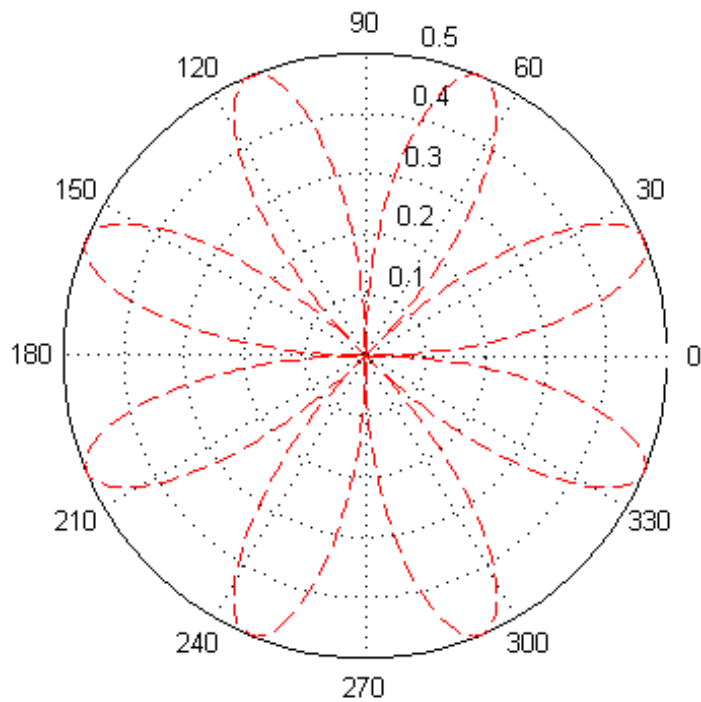

## See Also

[cart2pol](#) | [compass](#) | [LineSpec](#) | [plot](#) | [pol2cart](#) | [rose](#)

**Purpose**

Polynomial with specified roots

**Syntax**

`p = poly(A)`  
`p = poly(r)`

**Description**

`p = poly(A)` where  $A$  is an  $n$ -by- $n$  matrix returns an  $n+1$  element row vector whose elements are the coefficients of the characteristic polynomial,  $\det(\lambda I - A)$ . The coefficients are ordered in descending powers: if a vector  $c$  has  $n+1$  components, the polynomial it represents is  $c_1\lambda^n + c_2\lambda^{n-1} + \dots + c_n\lambda + c_{n+1}$

`p = poly(r)` where  $r$  is a vector returns a row vector whose elements are the coefficients of the polynomial whose roots are the elements of  $r$ .

**Tips**

Note the relationship of this command to

`r = roots(p)`

which returns a column vector whose elements are the roots of the polynomial specified by the coefficients row vector  $p$ . For vectors, `roots` and `poly` are inverse functions of each other, up to ordering, scaling, and roundoff error.

**Examples**

MATLAB displays polynomials as row vectors containing the coefficients ordered by descending powers. The characteristic equation of the matrix

$A =$

1	2	3
4	5	6
7	8	0

is returned in a row vector by `poly`:

`p = poly(A)`

`p =`  

1	-6	-72	-27
---	----	-----	-----

The roots of this polynomial (eigenvalues of matrix A) are returned in a column vector by `roots`:

```
r = roots(p)
```

```
r =
```

```
 12.1229
 -5.7345
 -0.3884
```

## Algorithms

The algorithms employed for `poly` and `roots` illustrate an interesting aspect of the modern approach to eigenvalue computation. `poly(A)` generates the characteristic polynomial of A, and `roots(poly(A))` finds the roots of that polynomial, which are the eigenvalues of A. But both `poly` and `roots` use `eig`, which is based on similarity transformations. The classical approach, which characterizes eigenvalues as roots of the characteristic polynomial, is actually reversed.

If A is an n-by-n matrix, `poly(A)` produces the coefficients `c(1)` through `c(n+1)`, with `c(1) = 1`, in

$$\det(\lambda I - A) = c_1 \lambda^n + \dots + c_n \lambda + c_{n+1}$$

The algorithm is

```
z = eig(A);
c = zeros(n+1,1); c(1) = 1;
for j = 1:n
 c(2:j+1) = c(2:j+1) - z(j)*c(1:j);
end
```

This recursion is easily derived by expanding the product.

$$(\lambda - \lambda_1)(\lambda - \lambda_2)\dots(\lambda - \lambda_n)$$

It is possible to prove that `poly(A)` produces the coefficients in the characteristic polynomial of a matrix within roundoff error of A. This is



true even if the eigenvalues of  $A$  are badly conditioned. The traditional algorithms for obtaining the characteristic polynomial, which do not use the eigenvalues, do not have such satisfactory numerical properties.

**See Also**

`conv` | `polyval` | `residue` | `roots`

# polyarea

---

**Purpose** Area of polygon

**Syntax**  
`A = polyarea(X,Y)`  
`A = polyarea(X,Y,dim)`

**Description** `A = polyarea(X,Y)` returns the area of the polygon specified by the vertices in the vectors `X` and `Y`.

If `X` and `Y` are matrices of the same size, then `polyarea` returns the area of polygons defined by the columns `X` and `Y`.

If `X` and `Y` are multidimensional arrays, `polyarea` returns the area of the polygons in the first nonsingleton dimension of `X` and `Y`.

`A = polyarea(X,Y,dim)` operates along the dimension specified by scalar `dim`.

## Examples **Find Area of Polygon**

```
L = linspace(0,2.*pi,9); xv = 1.2*cos(L)';yv = 1.2*sin(L)';
xv = [xv ; xv(1)]; yv = [yv ; yv(1)];
A = polyarea(xv,yv)
```

```
A =
```

```
4.0729
```

```
plot(xv,yv); title(['Area = ' num2str(A)]); axis image
```

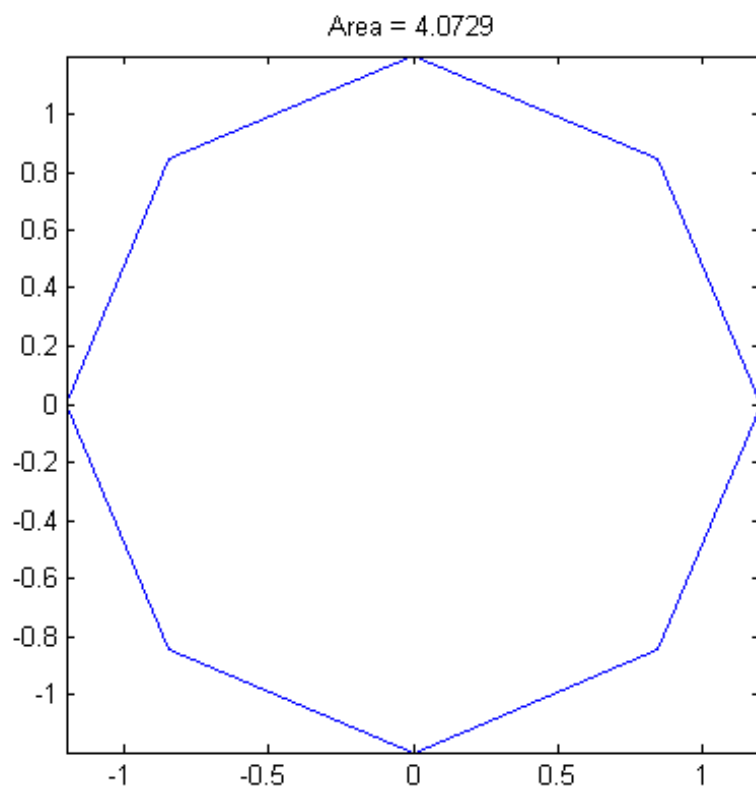

**See Also** [convhull](#) | [inpolygon](#) | [rectint](#)

# polyder

---

## Purpose

Polynomial derivative

## Syntax

```
k = polyder(p)
k = polyder(a,b)
[q,d] = polyder(b,a)
```

## Description

The `polyder` function calculates the derivative of polynomials, polynomial products, and polynomial quotients. The operands `a`, `b`, and `p` are vectors whose elements are the coefficients of a polynomial in descending powers.

`k = polyder(p)` returns the derivative of the polynomial `p`.

`k = polyder(a,b)` returns the derivative of the product of the polynomials `a` and `b`.

`[q,d] = polyder(b,a)` returns the numerator `q` and denominator `d` of the derivative of the polynomial quotient `b/a`.

## Examples

The derivative of the product

$$(3x^2 + 6x + 9)(x^2 + 2x)$$

is obtained with

```
a = [3 6 9];
b = [1 2 0];
k = polyder(a,b)
k =
 12 36 42 18
```

This result represents the polynomial

$$12x^3 + 36x^2 + 42x + 18$$

## See Also

`conv` | `deconv`

**Purpose**

Polynomial eigenvalue problem

**Syntax**

```
[X,e] = polyeig(A0,A1,...,Ap)
e = polyeig(A0,A1,...,Ap)
[X, e, s] = polyeig(A0,A1,...,AP)
```

**Description**

`[X,e] = polyeig(A0,A1,...,Ap)` solves the polynomial eigenvalue problem of degree  $p$

$$(A_0 + \lambda A_1 + \dots + \lambda^p A_p)x = 0$$

where polynomial degree  $p$  is a non-negative integer, and  $A_0, A_1, \dots, A_p$  are input matrices of order  $n$ . The output consists of a matrix  $X$  of size  $n$ -by- $n \times p$  whose columns are the eigenvectors, and a vector  $e$  of length  $n \times p$  containing the eigenvalues.

If  $\lambda$  is the  $j$ th eigenvalue in  $e$ , and  $x$  is the  $j$ th column of eigenvectors in  $X$ , then  $(A_0 + \lambda A_1 + \dots + \lambda^p A_p)x$  is approximately 0.

`e = polyeig(A0,A1,...,Ap)` is a vector of length  $n \times p$  whose elements are the eigenvalues of the polynomial eigenvalue problem.

`[X, e, s] = polyeig(A0,A1,...,AP)` also returns a vector  $s$  of length  $p \times n$  containing condition numbers for the eigenvalues. At least one of  $A_0$  and  $A_p$  must be nonsingular. Large condition numbers imply that the problem is close to a problem with multiple eigenvalues.

**Tips**

Based on the values of  $p$  and  $n$ , `polyeig` handles several special cases:

- $p = 0$ , or `polyeig(A)` is the standard eigenvalue problem: `eig(A)`.
- $p = 1$ , or `polyeig(A,B)` is the generalized eigenvalue problem: `eig(A,-B)`.
- $n = 1$ , or `polyeig(a0,a1,...,ap)` for scalars  $a_0, a_1, \dots, a_p$  is the standard polynomial problem: `roots([ap ... a1 a0])`.

If both  $A_0$  and  $A_p$  are singular the problem is potentially ill-posed. Theoretically, the solutions might not exist or might not be unique. Computationally, the computed solutions might be inaccurate. If one, but not both, of  $A_0$  and  $A_p$  is singular, the problem is well posed, but some of the eigenvalues might be zero or infinite.

Note that scaling  $A_0, A_1, \dots, A_p$  to have  $\text{norm}(A_i)$  roughly equal 1 may increase the accuracy of `polyeig`. In general, however, this cannot be achieved. (See Tisseur [3] for more detail.)

## Algorithms

The `polyeig` function uses the QZ factorization to find intermediate results in the computation of generalized eigenvalues. It uses these intermediate results to determine if the eigenvalues are well-determined. See the descriptions of `eig` and `qz` for more on this.

## References

- [1] Dedieu, Jean-Pierre Dedieu and Francoise Tisseur, "Perturbation theory for homogeneous polynomial eigenvalue problems," *Linear Algebra Appl.*, Vol. 358, pp. 71-94, 2003.
- [2] Tisseur, Francoise and Karl Meerbergen, "The quadratic eigenvalue problem," *SIAM Rev.*, Vol. 43, Number 2, pp. 235-286, 2001.
- [3] Francoise Tisseur, "Backward error and condition of polynomial eigenvalue problems" *Linear Algebra Appl.*, Vol. 309, pp. 339-361, 2000.

## See Also

`condeig` | `eig` | `qz`

**Purpose** Polynomial curve fitting

**Syntax**

```
p = polyfit(x,y,n)
[p,S] = polyfit(x,y,n)
[p,S,mu] = polyfit(x,y,n)
```

**Description** `p = polyfit(x,y,n)` finds the coefficients of a polynomial  $p(x)$  of degree  $n$  that fits the data,  $p(x(i))$  to  $y(i)$ , in a least squares sense. The result `p` is a row vector of length  $n+1$  containing the polynomial coefficients in descending powers:

$$p(x) = p_1x^n + p_2x^{n-1} + \dots + p_nx + p_{n+1}.$$

`[p,S] = polyfit(x,y,n)` returns the polynomial coefficients `p` and a structure `S` for use with `polyval` to obtain error estimates or predictions. Structure `S` contains fields `R`, `df`, and `normr`, for the triangular factor from a QR decomposition of the Vandermonde matrix of `x`, the degrees of freedom, and the norm of the residuals, respectively. If the data `y` are random, an estimate of the covariance matrix of `p` is  $(R \backslash y - p) * (R \backslash y - p)' * \text{normr}^2 / \text{df}$ , where `R \backslash y` is the inverse of `R`. If the errors in the data `y` are independent normal with constant variance, `polyval` produces error bounds that contain at least 50% of the predictions.

`[p,S,mu] = polyfit(x,y,n)` finds the coefficients of a polynomial in

$$\hat{x} = \frac{x - \mu_1}{\mu_2}$$

where  $\mu_1 = \text{mean}(x)$  and  $\mu_2 = \text{std}(x)$ . `mu` is the two-element vector `[mu1,mu2]`. This centering and scaling transformation improves the numerical properties of both the polynomial and the fitting algorithm.

## Examples **Fit Polynomial to Error Function**

This example involves fitting the error function,  $\text{erf}(x)$ , by a polynomial in `x`. This is a risky project because  $\text{erf}(x)$  is a bounded function, while polynomials are unbounded, so the fit might not be very good.

First generate a vector of  $x$  points, equally spaced in the interval  $[0, 2.5]$ , then evaluate  $\text{erf}(x)$  at those points.

```
x = (0: 0.1: 2.5)';
y = erf(x);
```

The coefficients in the approximating polynomial of degree 6 are

```
p = polyfit(x,y,6)
```

```
p =
```

```
 0.0084 -0.0983 0.4217 -0.7435 0.1471 1.1064 0.0004
```

There are seven coefficients, and the polynomial is

$$0.0084x^6 - 0.0983x^5 + 0.4217x^4 - 0.7435x^3 + 0.1471x^2 + 1.1064x + 0.0004$$

To see how good the fit is, evaluate the polynomial at the data points.

```
f = polyval(p,x);
```

A table showing the data, fit, and error is

```
table = [x y f y-f]
```

```
table =
```

```
 0 0 0.0004 -0.0004
 0.1000 0.1125 0.1119 0.0006
 0.2000 0.2227 0.2223 0.0004
 0.3000 0.3286 0.3287 -0.0001
 0.4000 0.4284 0.4288 -0.0004
 0.5000 0.5205 0.5209 -0.0004
 0.6000 0.6039 0.6041 -0.0002
```



0.7000	0.6778	0.6778	0.0000
0.8000	0.7421	0.7418	0.0003
0.9000	0.7969	0.7965	0.0004
1.0000	0.8427	0.8424	0.0003
1.1000	0.8802	0.8800	0.0002
1.2000	0.9103	0.9104	-0.0000
1.3000	0.9340	0.9342	-0.0002
1.4000	0.9523	0.9526	-0.0003
1.5000	0.9661	0.9664	-0.0003
1.6000	0.9763	0.9765	-0.0002
1.7000	0.9838	0.9838	0.0000
1.8000	0.9891	0.9889	0.0002
1.9000	0.9928	0.9925	0.0003
2.0000	0.9953	0.9951	0.0002
2.1000	0.9970	0.9969	0.0001
2.2000	0.9981	0.9982	-0.0001
2.3000	0.9989	0.9991	-0.0003
2.4000	0.9993	0.9995	-0.0002
2.5000	0.9996	0.9994	0.0002

On this interval, the interpolated values and the actual values agree fairly closely. Outside this interval, the extrapolated values quickly diverge from the actual data values, as the following plot demonstrates.

```
x = (0: 0.1: 5)';
y = erf(x);
f = polyval(p,x);
plot(x,y,'o',x,f,'-')
axis([0 5 0 2])
```

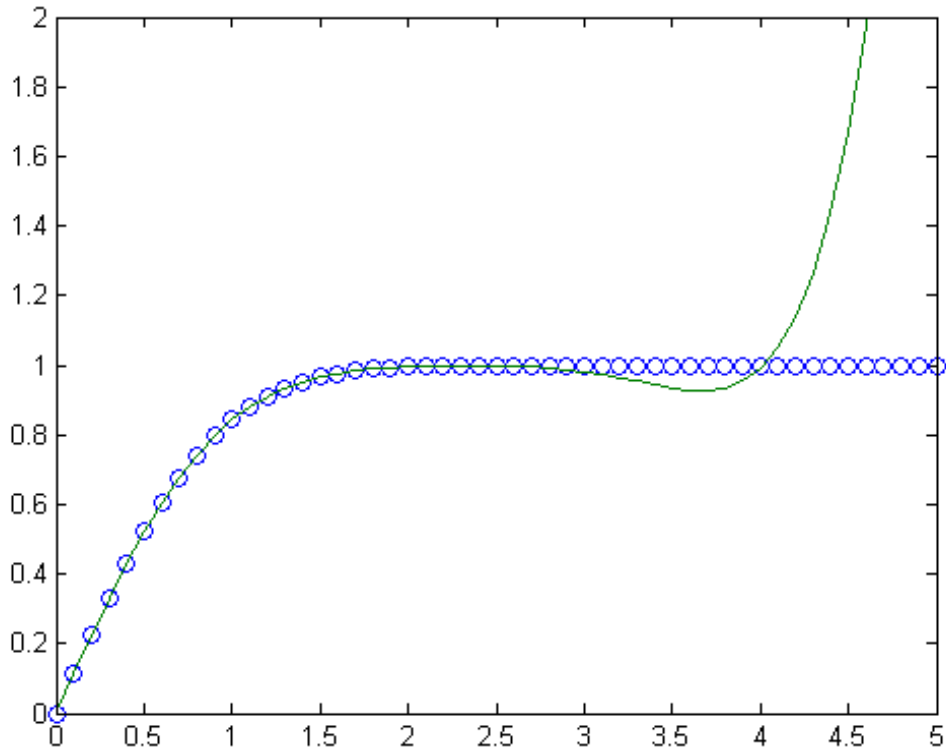

## Algorithms

The `polyfit` MATLAB file forms the Vandermonde matrix,  $V$ , whose elements are powers of  $x$ .  $v_{i,j} = x_i^{n-j}$

It then uses the backslash operator, `\`, to solve the least squares problem  $Vp \cong y$ .

See “Programmatic Fitting” for information about fitting different functions of  $x$ .

**See Also**

`poly` | `polyval` | `roots` | `lskov` | `cov`

# polyint

---

**Purpose** Integrate polynomial analytically

**Syntax** `polyint(p,k)`  
`polyint(p)`

**Description** `polyint(p,k)` returns a polynomial representing the integral of polynomial `p`, using a scalar constant of integration `k`. Specify `p` and `k` as type `double` or `single`.

`polyint(p)` assumes a constant of integration `k=0`.

**See Also** `polyder` | `polyval` | `polyvalm` | `polyfit`

**Purpose**

Polynomial evaluation

**Syntax**

```
y = polyval(p,x)
[y,delta] = polyval(p,x,S)
y = polyval(p,x,[],mu)
[y,delta] = polyval(p,x,S,mu)
```

**Description**

`y = polyval(p,x)` returns the value of a polynomial of degree  $n$  evaluated at  $x$ . The input argument  $p$  is a vector of length  $n+1$  whose elements are the coefficients in descending powers of the polynomial to be evaluated.

$$y = p_1x^n + p_2x^{n-1} + \dots + p_nx + p_{n+1}$$

$x$  can be a matrix or a vector. In either case, `polyval` evaluates  $p$  at each element of  $x$ .

`[y,delta] = polyval(p,x,S)` uses the optional output structure  $S$  generated by `polyfit` to generate error estimates `delta`. `delta` is an estimate of the standard deviation of the error in predicting a future observation at  $x$  by  $p(x)$ . If the coefficients in  $p$  are least squares estimates computed by `polyfit`, and the errors in the data input to `polyfit` are independent, normal, and have constant variance, then `y±delta` contains at least 50% of the predictions of future observations at  $x$ .

`y = polyval(p,x,[],mu)` or `[y,delta] = polyval(p,x,S,mu)` use  $\hat{x} = (x - \mu_1) / \mu_2$  in place of  $x$ . In this equation,  $\mu_1 = \text{mean}(x)$  and  $\mu_2 = \text{std}(x)$ . The centering and scaling parameters  $\text{mu} = [\mu_1, \mu_2]$  are optional output computed by `polyfit`.

**Tips**

The `polyvalm(p,x)` function, with  $x$  a matrix, evaluates the polynomial in a matrix sense. See `polyvalm` for more information.

# polyval

---

## Examples

The polynomial  $p(x) = 3x^2 + 2x + 1$  is evaluated at  $x = 5, 7,$  and  $9$  with

```
p = [3 2 1];
polyval(p,[5 7 9])
```

which results in

```
ans =
```

```
86 162 262
```

For another example, see [polyfit](#).

## See Also

[polyfit](#) | [polyvalm](#) | [polyder](#) | [polyint](#)

**Purpose** Matrix polynomial evaluation

**Syntax** `Y = polyvalm(p,X)`

**Description** `Y = polyvalm(p,X)` evaluates a polynomial in a matrix sense. This is the same as substituting matrix `X` in the polynomial `p`.

Polynomial `p` is a vector whose elements are the coefficients of a polynomial in descending powers, and `X` must be a square matrix.

**Examples** The Pascal matrices are formed from Pascal's triangle of binomial coefficients. Here is the Pascal matrix of order 4.

```
X = pascal(4)
X =
 1 1 1 1
 1 2 3 4
 1 3 6 10
 1 4 10 20
```

Its characteristic polynomial can be generated with the `poly` function.

```
p = poly(X)
p =
 1 -29 72 -29 1
```

This represents the polynomial  $x^4 - 29x^3 + 72x^2 - 29x + 1$ .

Pascal matrices have the curious property that the vector of coefficients of the characteristic polynomial is palindromic; it is the same forward and backward.

Evaluating this polynomial at each element is not very interesting.

```
polyval(p,X)
ans =
 16 16 16 16
 16 15 -140 -563
 16 -140 -2549 -12089
```

# polyvalm

---

```
16 -563 -12089 -43779
```

But evaluating it in a matrix sense is interesting.

```
polyvalm(p,X)
ans =
 0 0 0 0
 0 0 0 0
 0 0 0 0
 0 0 0 0
```

The result is the zero matrix. This is an instance of the Cayley-Hamilton theorem: a matrix satisfies its own characteristic equation.

## See Also

[polyfit](#) | [polyval](#)



**Purpose** Base 2 power and scale floating-point numbers

**Syntax**  
`X = pow2(Y)`  
`X = pow2(F,E)`

**Description** `X = pow2(Y)` returns an array `X` whose elements are 2 raised to the power `Y`.  
`X = pow2(F,E)` computes  $x = f * 2^e$  for corresponding elements of `F` and `E`. The result is computed quickly by simply adding `E` to the floating-point exponent of `F`. Arguments `F` and `E` are real and integer arrays, respectively.

**Tips** This function corresponds to the ANSI C function `ldexp()` and the IEEE floating-point standard function `scalbn()`.

**Examples** For IEEE arithmetic, the statement `X = pow2(F,E)` yields the values:

F	E	X
1/2	1	1
pi/4	2	pi
-3/4	2	-3
1/2	-51	eps
1-eps/2	1024	realmax
1/2	-1021	realmin

**See Also** `log2` | `exp` | `hex2num` | `realmax` | `realmin` | `power` | `mpower`

# power, .^

---

**Purpose** Element-wise power

**Syntax**  
`C = A.^B`  
`C = power(A,B)`

**Description** `C = A.^B` raises each element of `A` to the corresponding power in `B`.

`C = power(A,B)` is an alternate way to execute `A.^B`, but is rarely used. It enables operator overloading for classes.

## Input Arguments

### A - Base

scalar | vector | matrix | multidimensional array

Base, specified as a scalar, vector, matrix, or multidimensional array. Inputs `A` and `B` must be the same size unless one is a scalar. A scalar value expands into an array of the same size as the other input.

### Data Types

single | double | int8 | int16 | int32 | int64 | uint8 | uint16 | uint32 | uint64 | logical | char

**Complex Number Support:** Yes

### B - Exponent

scalar | vector | matrix | multidimensional array

Exponent, specified as a scalar, vector, matrix, or multidimensional array. Inputs `A` and `B` must be the same size unless one is a scalar. A scalar value expands into an array of the same size as the other input.

### Data Types

single | double | int8 | int16 | int32 | int64 | uint8 | uint16 | uint32 | uint64 | logical | char

**Complex Number Support:** Yes

## Examples

### Square Each Element of Vector

Create a vector, `A`, and square each element.

```
A = 1:5;
C = A.^2
```

```
C =
```

```
 1 4 9 16 25
```

### Find Inverse of Each Matrix Element

Create a matrix, A, and take the inverse of each element.

```
A = [1 2 3; 4 5 6; 7 8 9];
C = A.^-1
```

```
C =
```

```
 1.0000 0.5000 0.3333
 0.2500 0.2000 0.1667
 0.1429 0.1250 0.1111
```

An inversion of the elements is not equal to the inverse of the matrix, which is instead written  $A^{-1}$  or `inv(A)`.

### Find Roots of Number

Calculate the roots of -1 to the 1/3 power.

```
A = -1;
B = 1/3;
C = A.^B
```

```
C =
```

```
 0.5000 + 0.8660i
```

For negative base A and noninteger B, if `abs(B)` is less than 1, the power function returns the complex roots of A.

Use the `nthroot` function to obtain the real roots.

## power, .^

---

```
C = nthroot(A,3)
```

```
C =
```

```
-1
```

### See Also

realpow | mpower | nthroot

**Purpose** Evaluate piecewise polynomial

**Syntax** `v = ppval(pp,xx)`

**Description** `v = ppval(pp,xx)` returns the value of the piecewise polynomial  $f$ , contained in `pp`, at the entries of `xx`. You can construct `pp` using the functions `pchip`, `spline`, or the spline utility `mkpp`.

`v` is obtained by replacing each entry of `xx` by the value of  $f$  there. If  $f$  is scalar-valued, `v` is of the same size as `xx`. `xx` may be  $N$ -dimensional.

If `pp` was constructed by `pchip`, `spline`, or `mkpp` using the orientation of non-scalar function values specified for those functions, then:

If  $f$  is  $[D1, \dots, Dr]$ -valued, and `xx` is a vector of length  $N$ , then `V` has size  $[D1, \dots, Dr, N]$ , with `V(:,...,:,J)` the value of  $f$  at `xx(J)`.

If  $f$  is  $[D1, \dots, Dr]$ -valued, and `xx` has size  $[N1, \dots, Ns]$ , then `V` has size  $[D1, \dots, Dr, N1, \dots, Ns]$ , with `V(:,...,:, J1, ..., Js)` the value of  $f$  at `xx(J1, ..., Js)`.

## Examples

Compare the result of integrating  $\cos(x)$  between 0 and 10 to the result of integrating a piece-wise polynomial approximation of the same function.

```
a = 0; b = 10;
int1 = integral(@cos,a,b)
```

```
int1 =
 -0.5440
```

Create a piece-wise polynomial approximation of  $\cos(x)$  and integrate over the same interval.

```
x = a:b;
y = cos(x);
pp = spline(x,y);
int2 = integral(@(x)ppval(pp,x),a,b)
```

```
int2 =
```

# ppval

---

-0.5485

## **See Also**

mkpp | spline | unmkpp

**Purpose**

Folder containing preferences, history, and layout files

**Syntax**

```
prefdir
folder = prefdir
folder = prefdir(1)
```

**Description**

prefdir returns the folder that contains

- Preferences for MATLAB and related products (matlab.prf)
- Command history file (History.xml)
- MATLAB shortcuts (shortcuts\_2.xml)
- MATLAB desktop layout files (MATLABDesktop.xml and Your\_Saved\_LayoutMATLABLayout.xml)
- Other related files

folder = prefdir assigns to folder the name of the folder containing preferences and related files.

folder = prefdir(1) creates a folder for preferences and related files if one does not exist. If the folder does exist, the name is assigned to folder.

**Tips**

- You must have write access to the preferences folder. Otherwise, MATLAB generates an error in the Command Window when you try to change preferences. This can happen if the folder is hidden, for example: myname/.matlab/R2009a.

**Examples**

View the location of the preferences folder:

```
prefdir
```

---

Make the preferences folder become the current folder:

```
cd(prefdir)
```

# prefdir

---

```
% Then, view the files for customizing MathWorks products:
dir
```

On Windows platforms, go directly to the preferences folder in Microsoft Windows Explorer

```
winopen(prefdir)
```

## See Also

preferences | getpref | setpref

## How To

- “Preferences Folder and Files MATLAB Uses When Multiple MATLAB Releases Are Installed”



**Purpose** Open Preferences dialog box

**Syntax** preferences

**Description** preferences displays the Preferences dialog box, from which you can make changes to options for MATLAB and related products.

**See Also** prefdir

**How To** • “Preferences”

# primes

---

**Purpose** Prime numbers less than or equal to input value

**Syntax** `p = primes(n)`

**Description** `p = primes(n)` returns a row vector containing all the prime numbers less than or equal to `n`. The data type of `p` is the same as that of `n`.

**Input Arguments** **n - Input value**  
scalar, real integer value

Input value, specified as a scalar that is a real integer value.

**Example:** 10

**Example:** `int16(32)`

**Data Types**

`single` | `double` | `int8` | `int16` | `int32` | `int64` | `uint8` |  
`uint16` | `uint32` | `uint64`

**Examples** **Primes Less Than or Equal to 25**

```
p = primes(25)
```

```
p =
```

```
 2 3 5 7 11 13 17 19 23
```

**Primes Less Than or Equal to an Unsigned Integer**

```
n = uint16(12);
```

```
p = primes(n)
```

```
p =
```

```
 2 3 5 7 11
```

**See Also** `factor` | `isprime`

**Purpose** Print figure or save to file

### Contents

Syntax

“Description” on page 1-5177

“Printer Drivers” on page 1-5179

“Graphics Format Files” on page 1-5183

“Printing Options” on page 1-5187

“Paper Sizes” on page 1-5190

“Printing Tips” on page 1-5192

“Examples” on page 1-5195

“Alternatives” on page 1-5197

### Syntax

```
print
print('argument1', 'argument2', ...)
print(handle, 'filename')
print argument1 argument2 ... argumentn
```

### Description

`print` sends the contents of the current figure, including bitmap representations of any user interface controls, to the printer using the device and system printing command defined by `printopt`.

`print('argument1', 'argument2', ...)` is the function form of `print`. It enables you to pass variables for any input arguments. This form is useful for passing file names and handles (for example, `print(handle, 'filename')`). See “Batch Processing” on page 1-5196 for an example. Also see “Specifying the Figure to Print” on page 1-5195 for further examples.

---

**Note** Print input only takes string variables and handles as inputs. Strings passed in as cell array or struct inputs are not accepted.

---

# print

`print argument1 argument2 ... argumentn` prints the figure using the specified arguments.

The following arguments apply to both the function and the command form:

Argument	Description
<code>handle</code>	Print the specified object.
<code>filename</code>	Direct the output to the PostScript file designated by <code>filename</code> . If <code>filename</code> does not include an extension, <code>print</code> appends an appropriate extension.
<code>-ddriver</code>	Print the figure using the specified printer <code>driver</code> , (such as color PostScript). If you omit <code>-ddriver</code> , <code>print</code> uses the default value stored in <code>printopt.m</code> . The table in “Printer Drivers” on page 1-5179 lists all supported device types.
<code>-dformat</code>	Copy the figure to the system Clipboard (Microsoft Windows platforms only). To be valid, the <code>format</code> for this operation must be either <code>-dmeta</code> (Windows Enhanced Metafile) or <code>-dbitmap</code> (Windows Bitmap).
<code>-dformat filename</code>	Export the figure to the specified file using the specified graphics <code>format</code> (such as TIFF). The table of “Graphics Format Files” on page 1-5183 lists all supported graphics file formats.
<code>-smodelname</code>	Print the current Simulink model <code>modelName</code> .
<code>-options</code>	Specify print options that modify the action of the <code>print</code> command. (For example, the <code>-noui</code> option suppresses printing of user interface controls.) “Printing Options” on page 1-5187 lists available options.

## Printer Drivers

The following table shows the more widely used printer drivers supported by MATLAB software. If you do not specify a driver, the default setting shown in the previous table is used. For a list of all supported printer drivers, type `print -d` at the MATLAB prompt. Some things to remember:

- As indicated in “Description” on page 1-5177 the `-d` switch specifies a printer driver or a graphics file format:
  - Specifying a printer driver without a file name or printer name (the `-P` option) sends the output formatted by the specified driver to your default printer, which may not be what you want to do.

---

**Note** On Windows systems, when you use the `-P` option to identify a printer to use, if you specify any driver other than `-dwin` or `-dwinc`, MATLAB writes the output to a file with an appropriate extension but does not send it to the printer. You can then copy that file to a printer.

---

- Specifying a `-dmeta` or a `-dbitmap` graphics format without a file name places the graphic on the system Clipboard, if possible (Windows platforms only).
- Specifying any other graphics format without a file name creates a file in the current folder with a name such as `figureN.fmt`, where `N` is 1, 2, 3, ... and `fmt` indicates the format type, for example, `eps` or `png`.
- Several drivers come from a product called Ghostscript, which is shipped with MATLAB software. The last column indicates when Ghostscript is used.
- Not all drivers are supported on all platforms. Non support is noted in the first column of the table.
- If you specify a particular printer with the `-P` option and do not specify a driver, a default driver for that printer is selected, either by the operating system or by MATLAB, depending on the platform:

- On Windows, the driver associated with this particular printing device is used.
- On Macintosh and UNIX platforms, the driver specified in `printopt.m` is used

See *Selecting the Printer* in the Graphics documentation for more information.

---

**Note** Support for some print options will be removed in a future release. The affected formats have an asterisk (\*) next to the option string in the following table. The asterisks provide a link to the Web site which supplies a form for users to give feedback about these changes.

---

<b>Printer Driver</b>	<b>Print Command Option String</b>	<b>Ghostscript</b>
<b>Canon® BubbleJet BJ10e</b>	-dbj10e *	Yes
<b>Canon BubbleJet BJ200 color</b>	-dbj200 *	Yes
<b>Canon Color BubbleJet BJC-70/BJC-600/BJC-4000</b>	-dbjc600 *	Yes
<b>Canon Color BubbleJet BJC-800</b>	-dbjc800 *	Yes
<b>Epson®</b> and compatible 9- or 24-pin dot matrix print drivers	-depson *	Yes
<b>Epson</b> and compatible 9-pin with interleaved lines (triple resolution)	-deps9high *	Yes

<b>Printer Driver</b>	<b>Print Command Option String</b>	<b>Ghostscript</b>
<b>Epson LQ-2550</b> and compatible; color (not supported on HP-700)	-depsonc *	Yes
<b>Fujitsu® 3400/2400/1200</b>	-depsonc *	Yes
<b>HP® DesignJet 650C</b> color (not supported on Windows )	-ddnj650c *	Yes
<b>HP DeskJet 500</b>	-ddjet500 *	Yes
<b>HP DeskJet 500C</b> (creates black and white output)	-dcdjmono *	Yes
<b>HP DeskJet 500C</b> (with 24 bit/pixel color and high-quality Floyd-Steinberg color dithering) (not supported on Windows )	-dcdjcolor *	Yes
<b>HP DeskJet 500C/540C</b> color (not supported on Windows )	-dcdj500 *	Yes
<b>HP Deskjet 550C</b> color (not supported on Windows )	-dcdj550 *	Yes
<b>HP DeskJet and DeskJet Plus</b>	-ddeskjet *	Yes
<b>HP LaserJet</b>	-dlaserjet *	Yes
<b>HP LaserJet+</b>	-dljetplus *	Yes
<b>HP LaserJet IIP</b>	-dljet2p *	Yes

<b>Printer Driver</b>	<b>Print Command Option String</b>	<b>Ghostscript</b>
<b>HP LaserJet III</b>	-dljet3 *	Yes
<b>HP LaserJet 4, 5L and 5P</b>	-dljet4 *	Yes
<b>HP LaserJet 5 and 6</b>	-dpxlmono *	Yes
<b>HP PaintJet color</b>	-dpaintjet *	Yes
<b>HP PaintJet XL color</b>	-dpjxl *	Yes
<b>HP PaintJet XL color</b>	-dpjetxl *	Yes
<b>HP PaintJet XL300 color</b> (not supported on Windows )	-dpjxl300 *	Yes
<b>HPGL for HP 7475A and other compatible plotters.</b> (Renderer cannot be set to Z-buffer.)	-dhpgl *	No
<b>IBM 9-pin Proprinter</b>	-dibmpro *	Yes
<b>PostScript black and white</b>	-dps	No
<b>PostScript color</b>	-dpsc	No
<b>PostScript Level 2 black and white</b>	-dps2	No
<b>PostScript Level 2 color</b>	-dpsc2	No
<b>Windows color</b> (Windows only)	-dwinc	No
<b>Windows monochrome</b> (Windows only)	-dwin	No



---

**Tip** Generally, Level 2 PostScript files are smaller and are rendered more quickly when printing than Level 1 PostScript files. However, not all PostScript printers support Level 2, so determine the capabilities of your printer before using those drivers. Level 2 PostScript printing is the default for UNIX platforms. You can change this default by editing the `printopt.m` file. Likewise, if you want color PostScript printing to be the default instead of black-and-white PostScript printing, edit the line in the `printopt.m` file that reads `dev = '-dps2'`; to be `dev = '-dpsc2'`;

---

## Graphics Format Files

To save your figure as a graphics format file, specify a format switch and file name. To set the resolution of the output file for a built-in MATLAB format, use the `-r` switch. (For example, `-r300` sets the output resolution to 300 dots per inch.) The `-r` switch is also supported for Windows Enhanced Metafiles, JPEG, TIFF and PNG files, but is not supported for Ghostscript raster formats. For more information, see “Printing and Exporting without a Display” on page 1-5186 and “Resolution Considerations” on page 1-5189.

---

**Note** When you print to a file, the file name must have fewer than 128 characters, including path name. When you print to a file in your current folder, the filename must have fewer than 126 characters, because MATLAB places `./` or `.\` at the beginning of the filename when referring to it.

---

The following table shows the supported output formats for exporting from figures and the switch settings to use. In some cases, a format is available both as a MATLAB output filter and as a Ghostscript output filter. All formats except for EMF are supported on both Windows and UNIX platforms.

**Note** Support for some print options will be removed in a future release. The affected formats have an asterisk (\*) next to the option string in the following table. The asterisks provide a link to the Web site which supplies a form for users to give feedback about these changes.

<b>Graphics Format</b>	<b>Bitmap or Vector</b>	<b>Print Command Option String</b>	<b>MATLAB or Ghostscript</b>
<b>BMP</b> monochrome BMP	Bitmap	-dbmpmono	Ghostscript
<b>BMP</b> 24-bit BMP	Bitmap	-dbmp16m	Ghostscript
<b>BMP</b> 8-bit (256-color) BMP (this format uses a fixed colormap)	Bitmap	-dbmp256	Ghostscript
<b>BMP</b> 24-bit	Bitmap	-dbmp	MATLAB
<b>EMF</b>	Vector	-dmeta	MATLAB
<b>EPS</b> black and white	Vector	-deps	MATLAB
<b>EPS</b> color	Vector	-depsc	MATLAB
<b>EPS</b> Level 2 black and white	Vector	-deps2	MATLAB
<b>EPS</b> Level 2 color	Vector	-depsc2	MATLAB
<b>HDF</b> 24-bit	Bitmap	-dhdf	MATLAB
<b>ILL</b> (Adobe Illustrator)	Vector	-dill *	MATLAB
<b>JPEG</b> 24-bit	Bitmap	-djpeg	MATLAB
<b>PBM</b> (plain format) 1-bit	Bitmap	-dpbm	Ghostscript

<b>Graphics Format</b>	<b>Bitmap or Vector</b>	<b>Print Command Option String</b>	<b>MATLAB or Ghostscript</b>
<b>PBM</b> (raw format) 1-bit	Bitmap	-dpbmraw	Ghostscript
<b>PCX</b> 1-bit	Bitmap	-dpcxmono	Ghostscript
<b>PCX</b> 24-bit color PCX file format, three 8-bit planes	Bitmap	-dpcx24b	Ghostscript
<b>PCX</b> 8-bit newer color PCX file format (256-color)	Bitmap	-dpcx256	Ghostscript
<b>PCX</b> Older color PCX file format (EGA/VGA, 16-color)	Bitmap	-dpcx16	Ghostscript
<b>PDF</b> Color PDF file format	Vector	-dpdf	Ghostscript
<b>PGM</b> Portable Graymap (plain format)	Bitmap	-dpgm	Ghostscript
<b>PGM</b> Portable Graymap (raw format)	Bitmap	-dpgmraw	Ghostscript
<b>PNG</b> 24-bit	Bitmap	-dpng	MATLAB
<b>PPM</b> Portable Pixmap (plain format)	Bitmap	-dppm	Ghostscript
<b>PPM</b> Portable Pixmap (raw format)	Bitmap	-dppmraw	Ghostscript

<b>Graphics Format</b>	<b>Bitmap or Vector</b>	<b>Print Command Option String</b>	<b>MATLAB or Ghostscript</b>
SVG Scalable Vector Graphics (For Simulink Models Only)	Vector	-dsvg	MATLAB
TIFF 24-bit	Bitmap	-dtiff or -dtiffn	MATLAB
TIFF preview for EPS files	Bitmap	-tiff	

The TIFF image format is supported on all platforms by almost all word processors for importing images. The `-dtiffn` variant writes an uncompressed TIFF. JPEG is a lossy, highly compressed format that is supported on all platforms for image processing and for inclusion into HTML documents on the Web. To create these formats, MATLAB renders the figure using the Z-buffer rendering method and the resulting bitmap is then saved to the specified file.

## Printing and Exporting without a Display

On a UNIX platform (including Macintosh), where you can start in MATLAB `nodisplay` mode (`matlab -nodisplay`), you can print using most of the drivers you can use with a display and export to most of the same file formats. The PostScript and Ghostscript devices all function in `nodisplay` mode on UNIX platforms. The graphic devices `-djpeg`, `-dpng`, `-dtiff` (compressed TIFF bitmaps), and `-tiff` (EPS with TIFF preview) work as well, but under `nodisplay` they use Ghostscript to generate output instead of using the drivers built into MATLAB. However, Ghostscript ignores the `-r` option when generating `-djpeg`, `-dpng`, `-dtiff`, and `-tiff` image files. This means that you cannot vary the resolution of image files when running in `nodisplay` mode.

The same is true for the `-noFigureWindows` startup option which suppresses figures on all platforms. On Windows platforms the `-dwin`, `-dwinc`, and `-dsetup` options operate as usual under `-noFigureWindows`. However, the `printpreview` GUI does not function

in this mode. Naturally, the Windows only `-dwin` and `-dwinc` output formats cannot be used on UNIX or Mac platforms with or without a display.

The formats which you cannot generate in `nodisplay` mode on UNIX and Mac platforms are:

- `bitmap (-dbitmap)` — Windows bitmap file
- `bmp (-dbmp...)` — Monochrome and color bitmaps
- `hdf (-dhdf)` — Hierarchical Data Format
- `svg (-dsvg)` — Scalable Vector Graphics file
- `tifn (-dtifn)` — TIFF image file, no compression

In addition, `uicontrols` do not print or export in `nodisplay` mode.

## Printing Options

This table summarizes options that you can specify for `print`. The second column links to tutorials that provide operational details. Also see “Resolution Considerations” on page 1-5189 for information on controlling output resolution.

---

**Note** Support for some print options will be removed in a future release. The affected formats have an asterisk (\*) next to the option string in the following table. The asterisks provide a link to the Web site which supplies a form for users to give feedback about these changes.

---

Option	Description
<code>-adobecset *</code>	PostScript devices only. Use PostScript default character set encoding. See “Early PostScript 1 Printers”.
<code>-append</code>	PostScript devices only. Append figure to existing PostScript file. See “Settings That Are Driver Specific”.

Option	Description
-cmyk	PostScript devices only. Print with CMYK colors instead of RGB. See “Setting CMYK Color”.
-ddriver	Printing only. Printer driver to use. See “Printer Drivers” on page 1-5179 table.
-dformat	Exporting only. Graphics format to use. See “Graphics Format Files” table.
-dsetup *	Windows printing only. Display the (platform-specific) Print Setup dialog. Settings you make in it are saved, but nothing is printed.
-fhandle	Handle of figure to print. Note that you cannot specify both this option and the <i>-swindowtitle</i> option. See “Which Figure Is Printed”.
-loose	PostScript and Ghostscript printing only. Use loose bounding box for PostScript output. See “Producing Uncropped Figures”.
-noui	Suppress printing of user interface controls. See “Excluding User Interface Controls”.
-opengl	Render using the OpenGL algorithm. Note that you cannot specify this method in conjunction with <i>-zbuffer</i> or <i>-painters</i> . See “Selecting a Renderer”.
-painters	Render using the Painter’s algorithm. Note that you cannot specify this method in conjunction with <i>-zbuffer</i> or <i>-opengl</i> . See “Selecting a Renderer”.
-Pprinter	Specify name of printer to use. See “Selecting the Printer”.

Option	Description
<i>-rnumber</i>	PostScript and built-in raster formats, and Ghostscript vector format only. Specify resolution in dots per inch. Defaults to 90 for Simulink, 150 for figures in image formats and when printing in Z-buffer or OpenGL mode, screen resolution for metafiles, and 864 otherwise. Use <i>-r0</i> to specify screen resolution. For details, see “Resolution Considerations” on page 1-5189 and “Setting the Resolution”.
<i>-swindowtitle</i>	Specify name of Simulink system window to print. Note that you cannot specify both this option and the <i>-fhandle</i> option. See “Which Figure Is Printed”.
<i>-v</i>	Windows printing only. Display the Windows Print dialog box. The <i>v</i> stands for “verbose mode.”
<i>-zbuffer</i>	Render using the Z-buffer algorithm. Note that you cannot specify this method in conjunction with <i>-opengl</i> or <i>-painters</i> . See “Selecting a Renderer”.

### Resolution Considerations

Use *-rnumber* to specify the resolution of the generated output. In general, using a higher value will yield higher quality output but at the cost of larger output files. It affects the resolution and output size of all MATLAB built-in *raster* formats (which are identified in column four of the table in “Graphics Format Files” on page 1-5183).

---

**Note** Built-in graphics formats are generated directly from MATLAB without conversion through the Ghostscript library. Also, in headless (`nodisplay`) mode, writing to certain image formats is not done by built-in drivers, as it is when a display is being used. These formats are `-djpeg`, `-dtiff`, and `-dpng`. Furthermore, the `-dhdf` and `-dbmp` formats cannot be generated in headless mode (but you can substitute `-dbmp16m` for `-dbmp`). See “Printing and Exporting without a Display” on page 1-5186 for details on printing when not using a display.

---

Unlike the built-in MATLAB formats, graphic output generated via Ghostscript does not directly obey `-r` option settings. However, the intermediate PostScript file generated by MATLAB as input for the Ghostscript processor is affected by the `-r` setting and thus can indirectly influence the quality of the final Ghostscript generated output.

The effect of the `-r` option on output quality can be subtle at ordinary magnification when using the OpenGL or ZBuffer renderers and writing to one of the MATLAB built-in raster formats, or when generating vector output that contains an embedded raster image (for example, PostScript or PDF). The effect of specifying higher resolution is more apparent when viewing the output at higher magnification or when printed, since a larger `-r` setting provides more data to use when scaling the image.

When generating fully vectorized output (as when using the Painters renderer to output a vector format such as PostScript or PDF), the resolution setting affects the degree of detail of the output; setting resolution higher generates crisper output (but small changes in the resolution may have no observable effect). For example, the gap widths of lines that do not use a solid (‘-’) linestyle can be affected.

## Paper Sizes

MATLAB printing supports a number of standard paper sizes. You can select from the following list by setting the `PaperType` property of the figure or selecting a supported paper size from the Print dialog box.



<b>Property Value</b>	<b>Size (Width by Height)</b>
usletter	8.5 by 11 inches
uslegal	8.5 by 14 inches
tabloid	11 by 17 inches
A0	841 by 1189 mm
A1	594 by 841 mm
A2	420 by 594 mm
A3	297 by 420 mm
A4	210 by 297 mm
A5	148 by 210 mm
B0	1029 by 1456 mm
B1	728 by 1028 mm
B2	514 by 728 mm
B3	364 by 514 mm
B4	257 by 364 mm
B5	182 by 257 mm
arch-A	9 by 12 inches
arch-B	12 by 18 inches
arch-C	18 by 24 inches
arch-D	24 by 36 inches
arch-E	36 by 48 inches
A	8.5 by 11 inches
B	11 by 17 inches
C	17 by 22 inches

Property Value	Size (Width by Height)
D	22 by 34 inches
E	34 by 43 inches

## Printing Tips

### Setting Default Printer

You can edit the file `printopt.m` to set the default printer type and destination. If you want to set up a new printer, use the operating system printer management utilities. Restart MATLAB if you do not see a printer which is already setup.

### Figures with Resize Functions

The `print` command produces a warning when you print a figure having a callback routine defined for the figure `ResizeFcn`. To avoid the warning, set the figure `PaperPositionMode` property to `auto` or select **Auto (Actual Size, Centered)** in the **File > Print Preview** dialog box.

### Troubleshooting Microsoft Windows Printing

If you encounter problems such as segmentation violations, general protection faults, or application errors, or the output does not appear as you expect when using Microsoft printer drivers, try the following:

- If your printer is PostScript compatible, print with one of the MATLAB built-in PostScript drivers. There are various PostScript device options that you can use with `print`, which all start with `-dps`.
- The behavior you are experiencing might occur only with certain versions of the print driver. Contact the print driver vendor for information on how to obtain and install a different driver.
- Try printing with one of the MATLAB built-in Ghostscript devices. These devices use Ghostscript to convert PostScript files into other formats, such as HP LaserJet, PCX, Canon BubbleJet, and so on.

- Copy the figure as a Windows Enhanced Metafile using the **Edit > Copy Figure** menu item on the figure window menu or the `print -dmeta` option at the command line. You can then import the file into another application for printing.

You can set copy options in the figure's **File > Preferences > Copying Options** dialog box. The Windows Enhanced Metafile Clipboard format produces a better quality image than Windows Bitmap.

### Printing MATLAB GUIs

You can generally obtain better results when printing a figure window that contains MATLAB `uicontrols` by setting these key properties:

- Set the figure `PaperPositionMode` property to `auto`. This ensures that the printed version is the same size as the on-screen version. With `PaperPositionMode` set to `auto` MATLAB does not resize the figure to fit the current value of the `PaperPosition`. This is particularly important if you have specified a figure `ResizeFcn`, because if MATLAB resizes the figure during the print operation, `ResizeFcn` is automatically called.

To set `PaperPositionMode` on the current figure, use the command:

```
set(gcf, 'PaperPositionMode', 'auto')
```

- Set the figure `InvertHardcopy` property to `off`. By default, MATLAB changes the figure background color of printed output to white, but does not change the color of `uicontrols`. If you have set the background color, for example, to match the gray of the GUI devices, you must set `InvertHardcopy` to `off` to preserve the color scheme.

To set `InvertHardcopy` on the current figure, use the command:

```
set(gcf, 'InvertHardcopy', 'off')
```

- Use a color device if you want lines and text that are in color on the screen to be written to the output file as colored objects. Black and

white devices convert colored lines and text to black or white to provide the best contrast with the background and to avoid dithering.

- Use the `print` command's `-loose` option to keep a bounding box from being too tightly wrapped around objects contained in the figure. This is important if you have intentionally used space between `uicontrols` or axes and the edge of the figure and you want to maintain this appearance in the printed output.

If you print or export in `nodisplay` mode, none of the `uicontrols` the figure has will be visible. If you run code that adds `uicontrols` to a figure when the figure is invisible, the controls will not print until the figure is made visible.

## Printing Interpolated Shading with PostScript Drivers

You can print MATLAB surface objects (such as graphs created with `surf` or `mesh`) using interpolated colors. However, only patch objects that are composed of triangular faces can be printed using interpolated shading.

Printed output is always interpolated in RGB space, not in the colormap colors. This means that if you are using indexed color and interpolated face coloring, the printed output can look different from what is displayed on screen.

PostScript files generated for interpolated shading contain the color information of the graphics object's vertices and require the printer to perform the interpolation calculations. This can take an excessive amount of time and in some cases, printers might time out before finishing the print job. One solution to this problem is to interpolate the data and generate a greater number of faces, which can then be flat shaded.

To ensure that the printed output matches what you see on the screen, print using the `-zbuffer` option. To obtain higher resolution (for example, to make text look better), use the `-r` option to increase the resolution. There is, however, a tradeoff between the resolution and the size of the created PostScript file, which can be quite large at higher resolutions. The default resolution of 150 dpi generally produces good

results. You can reduce the size of the output file by making the figure smaller before printing it and setting the figure `PaperPositionMode` to `auto`, or by just setting the `PaperPosition` property to a smaller size.

## Examples

### Specifying the Figure to Print

Pass a figure handle as a variable to the function form of `print`. For example:

```
h = figure;
plot(1:4,5:8)
print(h)
```

Save the figure with the handle `h` to a PostScript file named `Figure2`, which can be printed later:

```
print(h, '-dps', 'Figure2.ps')
```

Pass in a file name as a variable:

```
filename = 'mydata';
print(h, '-dpSC', filename);
```

(Because a file name is specified, the figure will be printed to a file.)

### Specifying the Model to Print

Print a noncurrent Simulink model using the `-s` option with the title of the window (in this case, `f14`):

```
print('-sf14')
```

If the window title includes any spaces, you must call the function form rather than the command form of `print`. For example, this command saves the Simulink window title `Thruster Control`:

```
print('-sThruster Control')
```

To print the current system, use:

```
print('-s')
```

For information about issues specific to printing Simulink windows, see the Simulink documentation.

## Printing Figures at Screen Size

This example prints a surface plot with interpolated shading. Setting the current figure's (`gcf`) `PaperPositionMode` to `auto` enables you to resize the figure window and print it at the size you see on the screen. See “Printing Options” on page 1-5187 and “Printing Interpolated Shading with PostScript Drivers” on page 1-5194 for information on the `-zbuffer` and `-r200` options.

```
surf(peaks)
shading interp
set(gcf, 'PaperPositionMode', 'auto')
print('-dpsc2', '-zbuffer', '-r200')
```

For additional details, see “Printing Images” in the MATLAB Graphics documentation.

## Batch Processing

You can use the function form of `print` to pass variables containing file names. For example, this `for` loop uses file names stored in a cell array to create a series of graphs and prints each one with a different file name:

```
fnames = {'file1', 'file2', 'file3'};
for k=1:length(fnames)
 surf(peaks)
 print('-dtiff', '-r200', fnames{k})
end
```

`fnames` is a cell of string arrays so each element is a string.

## Tiff Preview

The command

```
print('-depsec', '-tiff', '-r300', 'picture1')
```

saves the current figure at 300 dpi, in a color Encapsulated PostScript file named `picture1.eps`. The `-tiff` option creates a 72 dpi TIFF preview, which many word processor applications can display on screen after you import the EPS file. This enables you to view the picture on screen within your word processor and print the document to a PostScript printer using a resolution of 300 dpi.

### Alternatives

Select **File > Print** from the figure window to open the Print dialog box and **File > Print Preview** to open the Print Preview GUI. For details, see “How to Print or Export”.

### See Also

`figure` | `hgsave` | `imwrite` | `orient` | `printdlg` | `printopt` | `saveas`

# printopt

---

**Purpose** Configure printer defaults

**Syntax** [pcmd,dev] = printopt

**Description** [pcmd,dev] = printopt returns strings containing the current system-dependent printing command and output device. printopt is a file used by print to produce the hard-copy output. You can edit the file printopt.m to set your default printer type and destination.

pcmd and dev are platform-dependent strings. pcmd contains the command that print uses to send a file to the printer. dev contains the printer driver or graphics format option for the print command. Their defaults are platform dependent.

Platform	Print Command	Driver or Format
Mac and UNIX	lpr -r	-dps2
Windows	COPY /B %s LPT1:	-dwin

**See Also** printdlg | print



**Purpose** Print dialog box

**Syntax**

```
printdlg
printdlg(fig)
printdlg('-crossplatform',fig)
printdlg('-setup',fig)
```

**Description** `printdlg` prints the current figure.

`printdlg(fig)` creates a modal dialog box from which you can print the figure window identified by the handle `fig`. Note that `uimenu`s do not print.

`printdlg('-crossplatform',fig)` displays the standard cross-platform MATLAB printing dialog rather than the built-in printing dialog box for Microsoft Windows computers. Insert this option before the `fig` argument.

`printdlg('-setup',fig)` forces the printing dialog to appear in a setup mode. This option is obsolete and will be removed in a future release.

---

**Note** If you want to set up a new printer, use the operating system printer management utilities. Restart MATLAB if you do not see the printer which is already setup.

---

---

**Note** A modal dialog box prevents the user from interacting with other windows before responding. For more information, see `WindowState` in the MATLAB Figure Properties.

---

**See Also** `print` | `printopt` | `printpreview`

# printpreview

---

**Purpose** Preview figure to print

## **Contents**

“Description” on page 1-5200

“Right Pane Controls” on page 1-5201

“The Layout Tab” on page 1-5202

“The Lines/Text Tab” on page 1-5203

“The Color Tab” on page 1-5205

“The Advanced Tab” on page 1-5207

“Alternatives” on page 1-5208

**Syntax** `printpreview`  
`printpreview(f)`

**Description** `printpreview` displays a dialog box showing the figure in the currently active figure window as it will print. A scaled version of the figure displays in the right-hand pane of the GUI.

`printpreview(f)` displays a dialog box showing the figure having the handle `f` as it will print.

Use the Print Preview dialog box, shown below, to control the layout and appearance of figures before sending them to a printer or print file. Controls are grouped into four tabbed panes: **Layout**, **Lines/Text**, **Color**, and **Advanced**.

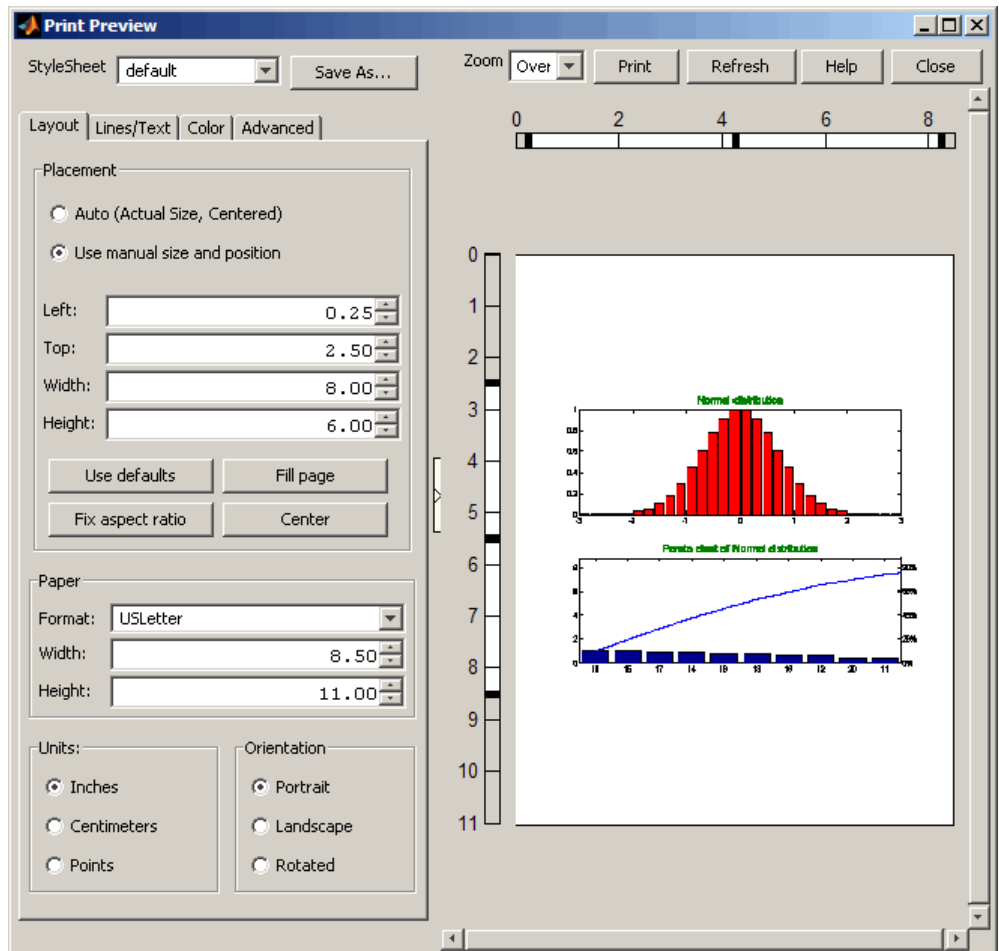

## Right Pane Controls

You can position and scale plots on the printed page using the rulers in the right-hand pane of the Print Preview dialog. Use the outer ruler handlebars to change margins. Moving them changes plot proportions. Use the center ruler handlebars to change the position of the plot on the page. Plot proportions do not change, but you can move portions of

the plot off the paper. The buttons on that pane let you refresh the plot, close the dialog (preserving all current settings), print the page immediately, or obtain context-sensitive help. Use the **Zoom** box and scroll bars to view and position page elements more precisely.

## The Layout Tab

Use the **Layout** tab, shown above, to control the paper format and placement of the plot on printed pages. The following table summarizes the **Layout** options:

<b>Group</b>	<b>Option</b>	<b>Description</b>
Placement	<b>Auto</b>	Let MATLAB decide placement of plot on page*
	<b>Use manual...</b>	Specify position parameters for plot on page*
	<b>Top, Left, Width, Height</b>	Standard position parameters in current units
	<b>Use defaults</b>	Revert to default position
	<b>Fill page</b>	Expand figure to fill printable area (see note below)
	<b>Fix aspect ratio</b>	Correct height/width ratio
	<b>Center</b>	Center plot on printed page
Paper	<b>Format</b>	U.S. and ISO® sheet size selector
	<b>Width, Height</b>	Sheet size in current units
Units	<b>Inches</b>	Use inches as units for dimensions and positions
	<b>Centimeters</b>	Use centimeters as units for dimensions and positions
	<b>Points</b>	Use points as units for dimensions and positions
Orientation	<b>Portrait</b>	Upright paper orientation

Group	Option	Description
	<b>Landscape</b>	Sideways paper orientation
	<b>Rotated</b>	Currently the same as <b>Landscape</b>

\* Selecting **Auto** in the Placement group sets the figure PaperPositionMode to 'auto' and disables the controls in that panel. Selecting **Use manual size and position** sets the figure PaperPositionMode to 'manual' and enables the controls. If you set PaperPositionMode programmatically, the print preview Placement controls respond accordingly.

---

**Note** Selecting the **Fill page** option changes the PaperPosition property to fill the page, allowing objects in normalized units to expand to fill the space. If an object within the figure has an absolute size, for example a table, it can overflow the page when objects with normalized units expand. To avoid having objects fall off the page, do not use **Fill page** under such circumstances.

---

### The Lines/Text Tab

Use the **Lines/Text** tab, shown below, to control the line weights, font characteristics, and headers for printed pages. The following table summarizes the **Lines/Text** options:

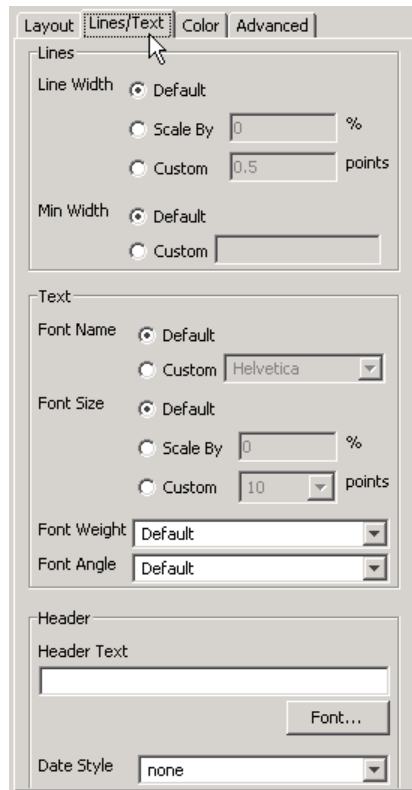

Group	Option	Description
Lines	<b>Line Width</b>	Scale all lines by a percentage from 0 upward (100 being no change), print lines at a specified point size, or default line widths used on the plot
	<b>Min Width</b>	Smallest line width (in points) to use when printing; defaults to 0.5 point
Text	<b>Font Name</b>	Select a system font for all text on plot, or default to fonts currently used on the plot

Group	Option	Description
	<b>Font Size</b>	Scale all text by a percentage from 0 upward (100 being no change), print text at a specified point size, or default to this
	<b>Font Weight</b>	Select Normal ... Bold font styling for all text from drop-down menu or default to the font weights used on the plot
	<b>Font Angle</b>	Select Normal, Italic or Oblique font styling for all text from drop-down menu or default to the font angles used on the plot
Header	<b>Header Text</b>	Type the text to appear on the header at the upper left of printed pages, or leave blank for no header
	<b>Date Style</b>	Select a date format to have today's date appear at the upper left of printed pages, or none for no date

### The Color Tab

Use the **Color** tab, shown below, to control how colors are printed for lines and backgrounds. The following table summarizes the **Color** options:

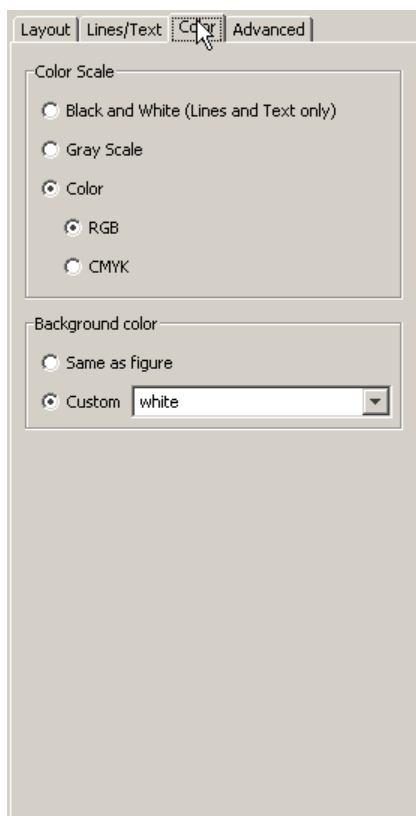

Group	Option	Description
Color Scale	<b>Black and White</b>	Select to print lines and text in black and white, but use color for patches and other objects
	<b>Gray Scale</b>	Convert colors to shades of gray on printed pages



Group	Option	Description
	<b>Color</b>	Print everything in color, matching colors on plot; select RGB (default) or CMYK color model for printing
Background Color	<b>Same as figure</b>	Print the figure's background color as it is
	<b>Custom</b>	Select a color name, or type a colorspec for the background; white (default) implies no background color, even on colored paper.

### The Advanced Tab

Use the **Advanced** tab, shown below, to control finer details of printing, such as limits and ticks, renderer, resolution, and the printing of UIControls. The following table summarizes the **Advanced** options:

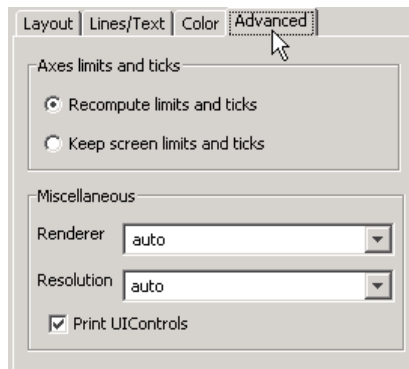

Group	Option	Description
Axes limits and ticks	<b>Recompute limits and ticks</b>	Redraw $x$ - and $y$ -axes ticks and limits based on printed plot size (default)
	<b>Keep limits and ticks</b>	Use the $x$ - and $y$ -axes ticks and limits shown on the plot when printing the previewed figure
Miscellaneous	<b>Renderer</b>	Select a rendering algorithm for printing: painters, zbuffer, opengl, or auto (default)
	<b>Resolution</b>	Select resolution to print at in dots per inch: 150, 300, 600, or auto (default), or type in any other positive value
	<b>Print UIControls</b>	Print all visible UIControls in the figure (default), or uncheck to exclude them from being printed

## Alternatives

Use **File > Print Preview** on the figure window menu to access the Print Preview dialog box, described below. For details, see “Using Print Preview”.

## See Also

printdlg | pagesetupdlg

## How To

- How to Print or Export

**Purpose**

Product of array elements

**Syntax**

```
B = prod(A)
B = prod(A,dim)
B = prod(__ ,type)
```

**Description**

`B = prod(A)` returns the product of the array elements of `A`.

- If `A` is a vector, then `prod(A)` returns the product of the elements.
- If `A` is a nonempty matrix, then `prod(A)` treats the columns of `A` as vectors and returns a row vector of the products of each column.
- If `A` is an empty 0-by-0 matrix, `prod(A)` returns 1.
- If `A` is a multidimensional array, then `prod(A)` acts along the first nonsingleton dimension and returns an array of products. The size of this dimension reduces to 1 while the sizes of all other dimensions remain the same.

`prod` computes and returns `B` as `single` if the input, `A`, is `single`. For all other numeric and logical data types, `prod` computes and returns `B` as `double`.

`B = prod(A,dim)` returns the products along dimension `dim`. For example, if `A` is a matrix, `prod(A,2)` is a column vector containing the products of each row.

`B = prod( __ ,type)` multiplies in and returns an array in the class specified by `type`, using any of the input arguments in the previous syntaxes. `type` can be `'double'` or `'native'`.

**Input Arguments****A - Input array**

vector | matrix | multidimensional array

Input array, specified as a vector, matrix, or multidimensional array.

## Data Types

double | single | int8 | int16 | int32 | int64 | uint8 |  
uint16 | uint32 | uint64 | logical

**Complex Number Support:** Yes

## dim - Dimension to operate along

positive integer scalar

Dimension to operate along, specified as a positive integer scalar. If no value is specified, the default is the first array dimension whose size does not equal 1.

Dimension  $dim$  indicates the dimension whose length reduces to 1. The  $size(B, dim)$  is 1, while the sizes of all other dimensions remain the same.

Consider a two-dimensional input array,  $A$ .

- If  $dim = 1$ , then  $prod(A, 1)$  returns a row vector containing the product of the elements in each column.
- If  $dim = 2$ , then  $prod(A, 2)$  returns a column vector containing the product of the elements in each row.

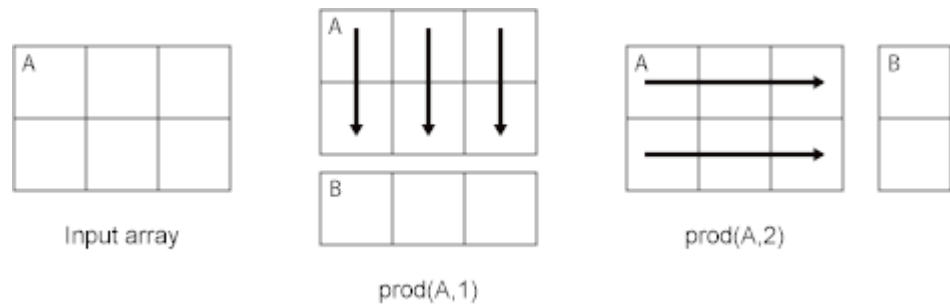

`prod` returns  $A$  if  $dim$  is greater than  $ndims(A)$ .

## Data Types

double | single | int8 | int16 | int32 | int64 | uint8 |  
uint16 | uint32 | uint64

**type - Output class**

'double' | 'native'

Output class, specified as 'double' or 'native', defines the data type that the operation is performed in and output in.

- If type is 'double', then prod computes and returns a double precision array, regardless of the input data type. For example, if A is single, then prod multiplies in and returns in double.
- If type is 'native', prod multiplies natively and returns an array with the same data type as the input array A. For example, if A is an 8-bit unsigned integer, prod multiplies natively and returns B with data type uint8.

**Data Types**

char

**Output Arguments****B - Product array**

scalar | vector | matrix | multidimensional array

Product array, returned as a scalar, vector, matrix, or multidimensional array.

The class of B is as follows:

- If the type argument is not used and the input is not single, then the output is double.
- If the type argument is not used and the input is single, then the output is single.
- If the type argument specifies 'double', then the output is double regardless of the input data type.
- If the type argument specifies 'native', then the output is the same data type as the input.

**Definitions****First Nonsingleton Dimension**

The first nonsingleton dimension is the first dimension of an array whose size is not equal to 1.

For example:

- If  $X$  is a 1-by- $n$  row vector, then the second dimension is the first nonsingleton dimension of  $X$ .
- If  $X$  is a 1-by-0-by- $n$  empty array, then the second dimension is the first nonsingleton dimension of  $X$ .
- If  $X$  is a 1-by-1-by-3 array, then the third dimension is the first nonsingleton dimension of  $X$ .

## Examples

### Product of Elements in Each Column

Create a 3-by-3 array whose elements correspond to their linear indices.

```
A=[1:3:7;2:3:8;3:3:9]
```

A =

```
 1 4 7
 2 5 8
 3 6 9
```

Find the product of the elements in each column.

```
B = prod(A)
```

B =

```
 6 120 504
```

The length of the first dimension is 1, and the length of the second dimension matches `size(A,2)`.

### Logical Input with Double Output

Create an array of logical values.

```
A = [true false; true true]
```

```
A =

 1 0
 1 1
```

Find the product of the elements in each column.

```
B = prod(A)
```

```
B =

 1 0
```

The output is double.

```
class(B)
```

```
ans =
```

```
double
```

### **Product of Elements in Each Row**

Create a 3-by-3 array whose elements correspond to their linear indices.

```
A=[1:3:7;2:3:8;3:3:9]
```

```
A =

 1 4 7
 2 5 8
 3 6 9
```

Find the product of the elements in each row and reduce the length of the second dimension to 1.

```
dim = 2;
B = prod(A,dim)
```

B =

```
28
80
162
```

The length of the first dimension matches `size(A,1)`, and the length of the second dimension is 1.

## Product of Elements in Each Plane

Create a 3-by-3-by-2 array whose elements correspond to their linear indices.

```
A=[1:3:7;2:3:8;3:3:9];
A(:,:,2)=[10:3:16;11:3:17;12:3:18]
```

A(:,:,1) =

```
1 4 7
2 5 8
3 6 9
```

A(:,:,2) =

```
10 13 16
11 14 17
12 15 18
```

Find the product of each element in the first plane with its corresponding element in the second plane.

```
dim = 3;
B = prod(A,dim)
```

B =



```
10 52 112
22 70 136
36 90 162
```

The length of the first dimension matches `size(A,1)`, the length of the second dimension matches `size(A,2)`, and the length of the third dimension is 1.

### Single-Precision Input treated as Double

Create a 3-by-3 array of single-precision values.

```
A = single([1200 1500 1800; 1300 1600 1900; 1400 1700 2000])
```

A =

```
1200 1500 1800
1300 1600 1900
1400 1700 2000
```

Find the product of the elements in each row by performing the multiplication in double precision.

```
B = prod(A,2, 'double')
```

B =

```
1.0e+09 *
3.2400
3.9520
4.7600
```

The output is double precision.

```
class(B)
```

```
ans =
```

```
double
```

## Integer Data Type for Input and Output

Create a 3-by-3 array of 8-bit unsigned integers.

```
A = uint8([1:3:7;2:3:8;3:3:9])
```

```
A =
```

```
 1 4 7
 2 5 8
 3 6 9
```

Find the product of the elements in each column natively in `uint8`.

```
B = prod(A, 'native')
```

```
B =
```

```
 6 120 255
```

The result is an array of 8-bit unsigned integers.

```
class(B)
```

```
ans =
```

```
uint8
```

## See Also

```
cumprod | diff | sum | ndims
```

**Purpose**

Profile execution time for function

**Syntax**

```
profile on
profile -history
profile -nohistory
profile -history -historysize integer
profile -timer clock
profile -history -historysize integer -timer clock
profile off
profile resume
profile clear
profile viewer
S = profile('status')
stats = profile('info')
```

**Description**

The `profile` function helps you debug and optimize MATLAB code files by tracking their execution time. For each MATLAB function, MATLAB local function, or MEX-function in the file, `profile` records information about execution time, number of calls, parent functions, child functions, code line hit count, and code line execution time. Some people use `profile` simply to see the child functions; see also `matlab.codetools.requiredFilesAndProducts` for that purpose. To open the Profiler graphical user interface, use the `profile viewer` syntax. By default, Profiler time is CPU time. The total time reported by the Profiler is not the same as the time reported using the `tic` and `toc` functions or the time you would observe using a stopwatch.

---

**Note** If your system uses Intel multi-core chips, you may want to restrict the active number of CPUs to 1 for the most accurate and efficient profiling. See “Multi-Core Processors — Setting for Most Accurate Profiling on Windows Systems” or “Multi-Core Processors — Setting for Most Accurate Profiling on Linux Systems” for details on how to do this.

---

`profile on` starts the Profiler, clearing previously recorded profile statistics. Note the following:

- You can specify all, none, or a subset, of the `history`, `historysize` and `timer` options with the `profile on` syntax.
- You can specify options in any order, including before or after `on`.
- If the Profiler is currently on and you specify `profile` with one of the options, MATLAB software returns an error message and the option has no effect. For example, if you specify `profile timer real`, MATLAB returns the following error: The profiler has already been started. `TIMER` cannot be changed.
- To change options, first specify `profile off`, and then specify `profile on` or `profile resume` with new options.

`profile -history` records the exact sequence of function calls. The `profile` function records, by default, up to 1,000,000 function entry and exit events. For more than 1,000,000 events, `profile` continues to record other profile statistics, but not the sequence of calls. To change the number of function entry and exit events that the `profile` function records, use the `historysize` option. By default, the `history` option is not enabled.

`profile -nohistory` disables further recording of the history (exact sequence of function calls). Use the `-nohistory` option after having previously set the `-history` option. All other profiling statistics continue to be collected.

`profile -history -historysize integer` specifies the number of function entry and exit events to record. By default, `historysize` is set to 1,000,000.

`profile -timer clock` specifies the type of time to use. Valid values for `clock` are:

- `'cpu'` — The Profiler uses computer time (the default).
- `'real'` — The Profiler uses wall-clock time.

For example, `cpu` time for the `pause` function is typically small, but `real` time accounts for the actual time paused, and therefore would be larger.

`profile -history -historysize integer -timer clock` specifies all of the options. Any order is acceptable, as is a subset.

`profile off` stops the Profiler.

`profile resume` restarts the Profiler without clearing previously recorded statistics.

`profile clear` clears the statistics recorded by `profile`.

`profile viewer` stops the Profiler and displays the results in the Profiler window. For more information, see [Profiling for Improving Performance in the Desktop Tools and Development Environment documentation](#).

`S = profile('status')` returns a structure containing information about the current status of the Profiler. The table lists the fields in the order that they appear in the structure.

Field	Values	Default Value
ProfilerStatus	'on' or 'off'	off
DetailLevel	'mmex'	'mmex'
Timer	'cpu' or 'real'	'cpu'
HistoryTracking	'on' or 'off'	'off'
HistorySize	integer	1000000

`stats = profile('info')` stops the Profiler and displays a structure containing the results. Use this function to access the data generated by `profile`. The table lists the fields in the order that they appear in the structure.

# profile

---

Field	Description
FunctionTable	Structure array containing statistics about each function called
FunctionHistory	Array containing function call history
ClockPrecision	Precision of the <code>profile</code> function's time measurement
ClockSpeed	Estimated clock speed of the CPU
Name	Name of the profiler

The `FunctionTable` field is an array of structures, where each structure contains information about one of the functions or local functions called during execution. The following table lists these fields in the order that they appear in the structure.

Field	Description
CompleteName	Full path to <code>FunctionName</code> , including local functions
FunctionName	Function name; includes local functions
FileName	Full path to <code>FunctionName</code> , with file extension, excluding local functions
Type	MATLAB functions, MEX-functions, and many other types of functions including MATLAB local functions, nested functions, and anonymous functions
NumCalls	Number of times the function was called
TotalTime	Total time spent in the function and its child functions
TotalRecursiveTime	No longer used.
Children	<code>FunctionTable</code> indices to child functions
Parents	<code>FunctionTable</code> indices to parent functions

Field	Description
ExecutedLines	<p>Array containing line-by-line details for the function being profiled.</p> <p>Column 1: Number of the line that executed. If a line was not executed, it does not appear in this matrix.</p> <p>Column 2: Number of times the line was executed</p> <p>Column 3: Total time spent on that line. Note: The sum of Column 3 entries does not necessarily add up to the function's TotalTime.</p>
IsRecursive	BOOLEAN value: Logical 1 (true) if recursive, otherwise logical 0 (false)
PartialData	BOOLEAN value: Logical 1 (true) if function was modified during profiling, for example by being edited or cleared. In that event, data was collected only up until the point when the function was modified.

## Examples

### Profile, View Results, and Save Profile Data as HTML

This example profiles the MATLAB `magic` command and then displays the results in the Profiler window. The example then retrieves the profile data on which the HTML display is based and uses the `profsave` command to save the profile data in HTML form.

```
profile on
plot(magic(35))
profile viewer
p = profile('info');
profsave(p,'profile_results')
```

## Profile, Save Profile Data to a MAT-File, and View Results

Another way to save profile data is to store it in a MAT-file. This example stores the profile data in a MAT-file, clears the profile data from memory, and then loads the profile data from the MAT-file. This example also shows a way to bring the reloaded profile data into the Profiler graphical interface as live profile data, not as a static HTML page.

```
p = profile('info');
save myprofiledata p
clear p
load myprofiledata
profview(0,p)
```

## Profile and Show Results Including History

This example illustrates an effective way to view the results of profiling when the history option is enabled. The history data describes the sequence of functions entered and exited during execution. The `profile` command returns history data in the `FunctionHistory` field of the structure it returns. The history data is a 2-by-n array. The first row contains Boolean values, where 0 means entrance into a function and 1 means exit from a function. The second row identifies the function being entered or exited by its index in the `FunctionTable` field. This example reads the history data and displays it in the MATLAB Command Window.

```
profile on -history
plot(magic(4));
p = profile('info');

for n = 1:size(p.FunctionHistory,2)
 if p.FunctionHistory(1,n)==0
 str = 'entering function: ';
 else
 str = 'exiting function: ';
 end
 disp([str p.FunctionTable(p.FunctionHistory(2,n)).FunctionName])
end
```



end

## See Also

[matlab.codetools.requiredFilesAndProducts](#) | [mlint](#) | [profsave](#)

## Related Examples

- [Profiling for Improving Performance](#)
- [“Profiling Parallel Code”](#)

# profsave

---

**Purpose** Save profile report in HTML format

**Syntax**

```
profsave
profsave(profinfo)
profsave(profinfo,dirname)
```

**Description** `profsave` executes the `profile('info')` function and saves the results in HTML format. `profsave` creates a separate HTML file for each function listed in the `FunctionTable` field of the structure returned by `profile`. By default, `profsave` stores the HTML files in a subfolder of the current folder named `profile_results`.

`profsave(profinfo)` saves the profiling results, `profinfo`, in HTML format. `profinfo` is a structure of profiling information returned by the `profile('info')` function.

`profsave(profinfo,dirname)` saves the profiling results, `profinfo`, in HTML format. `profsave` creates a separate HTML file for each function listed in the `FunctionTable` field of `profinfo` and stores them in the folder specified by `dirname`.

**Examples** Run profile and save the results.

```
profile on
plot(magic(5))
profile off
profsave(profile('info'),'myprofile_results')
```

**See Also** `profile`

**How To**

- [Profiling for Improving Performance](#)

**Purpose** Open Property Editor

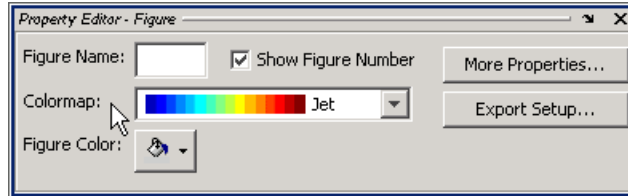

**Syntax**  
`propedit`  
`propedit(handle_list)`

**Description** `propedit` starts the Property Editor, a graphical user interface to the properties of graphics objects. If no current figure exists, `propedit` will create one.

`propedit(handle_list)` edits the properties for the object (or objects) in `handle_list`.

Starting the Property Editor enables plot editing mode for the figure.

**See Also** `inspect` | `plottedit` | `propertyeditor`

# propedit (COM)

---

<b>Purpose</b>	Open built-in property page for control
<b>Syntax</b>	<code>h.propedit</code> <code>propedit(h)</code>
<b>Description</b>	<p><code>h.propedit</code> requests the control to display its built-in property page. Note that some controls do not have a built-in property page. For those controls, this command fails.</p> <p><code>propedit(h)</code> is an alternate syntax for the same operation.</p>
<b>Tips</b>	COM functions are available on Microsoft Windows systems only.
<b>See Also</b>	<code>inspect</code>   <code>get (COM)</code>

<b>Purpose</b>	Class property names
<b>Syntax</b>	<pre>properties('classname') properties(obj) p = properties(...)</pre>
<b>Description</b>	<p><code>properties('classname')</code> displays the names of the public properties for the MATLAB class named by <code>classname</code>. The <code>properties</code> function also displays inherited properties.</p> <p><code>properties(obj)</code> <code>obj</code> can be either a scalar object or an array of objects. When <code>obj</code> is scalar, <code>properties</code> also returns dynamic properties. See “Dynamic Properties — Adding Properties to an Instance” for information on using dynamic properties.</p> <p><code>p = properties(...)</code> returns the property names in a cell array of strings.</p>
<b>Definitions</b>	<p>A property is public when its <code>GetAccess</code> attribute value is <code>public</code> and its <code>Hidden</code> attribute value is <code>false</code> (default values for these attributes). See “Property Attributes” for a complete list of attributes.</p> <p><code>properties</code> is also a MATLAB class-definition keyword. See <code>classdef</code> for more information on class definition keywords.</p>
<b>Examples</b>	<p>Retrieve the names of the public properties of class <code>memmapfile</code> and store the result in a cell array of strings:</p> <pre>p = properties('memmapfile'); p ans =      'writable'     'offset'     'format'     'repeat'     'filename'</pre>

# properties

---

Construct an instance of the MException class and get its properties names:

```
me = MException('Msg:ID', 'MsgText');
properties(me)
Properties for class MException:
```

```
 identifier
 message
 cause
 stack
```

## See Also

fieldnames | events | methods

## Tutorials

- “Properties”

**Purpose** Show or hide **Property Editor**

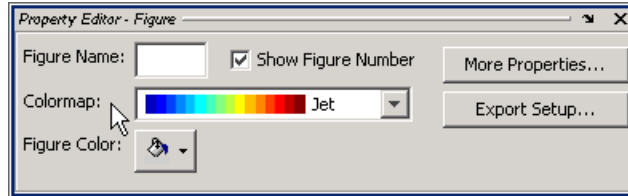

**Syntax**

```
propertyeditor('on')
propertyeditor('off')
propertyeditor
propertyeditor(figure_handle,...)
```



**Description** `propertyeditor('on')` displays the Property Editor tool on the current figure.

`propertyeditor('off')` hides the Property Editor on the current figure.

`propertyeditor` toggles the visibility of the Property Editor on the current figure. You can also use `propertyeditor('toggle')` instead for the same functionality.

`propertyeditor(figure_handle,...)` displays or hides the Property Editor on the figure specified by *figure\_handle*.

**Tips** If you call `propertyeditor` in a MATLAB program and subsequent lines depend on the Property Editor being fully initialized, follow it by `drawnow` to ensure complete initialization.

**Alternatives** To collectively enable **Plotting Tools**, use the large Plotting Tool icon  on the figure toolbar. To collectively disable the **Plotting Tools**, use the smaller icon . Open or close the **Property Editor** tool from the figure's **View** menu. For details, see “Customize Objects in Graph”.

# propertyeditor

---

## **See Also**

`plottools` | `plotbrowser` | `figurepalette` | `inspect`



**Purpose** Custom property list for object display

**Description** Use the PropertyGroup class to create custom property display lists for class derived from matlab.mixin.CustomDisplay.

**Construction** `P = matlab.mixin.util.PropertyGroup(propertyList)` constructs a property group with the supplied `propertyList`.

`P = matlab.mixin.util.PropertyGroup(propertyList,title)` displays `title` above the list of properties.

## Input Arguments

### **propertyList**

The `propertyList` is either a cell array of property names, or a scalar struct with property name-value pairs.

### **title**

Text to display above properties.

## Properties

### **NumProperties**

The number of properties in the `PropertyList`.

### **Attributes:**

Dependent	true
GetAccess	public
GetObservable	true
SetAccess	private
Transient	true

### **PropertyList**

The list of properties to display, stored as a scalar struct or a cell array of strings.

# matlab.mixin.util.PropertyGroup

---

## Attributes:

GetAccess	public
GetObservable	true
SetAccess	public
SetObservable	true

## Title

An optional Title for the PropertyGroup.

## Attributes:

GetAccess	public
GetObservable	true
SetAccess	public
SetObservable	true

## Copy Semantics

Value. To learn how value classes affect copy operations, see Copying Objects in the MATLAB documentation.

**See Also** `matlab.mixin.CustomDisplay`

## Related Examples

- “Custom Display Interface”
- “Customize Property Display”

## Concepts

- Property Attributes

**Purpose** Psi (polygamma) function

**Syntax**  
`Y = psi(X)`  
`Y = psi(k,X)`

**Description** `Y = psi(X)` evaluates the  $\psi$  function for each element of array `X`. `X` must be real and nonnegative. The  $\psi$  function, also known as the digamma function, is the logarithmic derivative of the gamma function

$$\begin{aligned}\psi(x) &= \text{digamma}(x) \\ &= \frac{d(\log(\Gamma(x)))}{dx} \\ &= \frac{d(\Gamma(x)) / dx}{\Gamma(x)}\end{aligned}$$

`Y = psi(k,X)` evaluates the  $k$ th derivative of  $\psi$  at the elements of `X`. `psi(0,X)` is the digamma function, `psi(1,X)` is the trigamma function, `psi(2,X)` is the tetragamma function, etc.

## Examples

### Example 1

Use the `psi` function to calculate Euler's constant,  $\gamma$ .

```
format long
-psi(1)
ans =
 0.57721566490153
```

```
-psi(0,1)
ans =
 0.57721566490153
```

### Example 2

The trigamma function of 2, `psi(1,2)`, is the same as  $(\pi^2/6) - 1$ .

```
format long
psi(1,2)
```

```
ans =
 0.64493406684823
```

```
pi^2/6 - 1
ans =
 0.64493406684823
```

## References

[1] Abramowitz, M. and I. A. Stegun, *Handbook of Mathematical Functions*, Dover Publications, 1965, Sections 6.3 and 6.4.

## See Also

gamma | gammainc | gammaln

## Purpose

Generate view of MATLAB file in specified format

## Syntax

```
publish(file)
publish(file,format)

publish(file,Name,Value)
publish(file,options)

my_doc = publish(file, ___)
```

## Description

`publish(file)` generates a view of a MATLAB file in HTML format for sharing your code. For example, `publish('myfile.m')` executes the code in `myfile.m` using the base workspace and saves the formatted code and results in `/html/myfile.html`. The `html` subfolder is relative to the `file` folder.

When MATLAB publishes a file, it can delete existing files from the output folder that start with the same name as `file`.

`publish(file,format)` generates a view of a MATLAB file in the specified file format. The resulting files save to the `html` subfolder for all file formats.

`publish(file,Name,Value)` generates a view of the MATLAB file, `file`, with options specified by one or more name-value pair arguments.

`publish(file,options)` uses the `options` structure to customize the output, which is useful when you want to preconfigure and save your options for repeated use. The `options` structure fields and values correspond to names and values of name-value pair arguments, respectively.

`my_doc = publish(file, ___ )` generates a view of the MATLAB file `file`, and returns a string indicating the path of the resulting output file. It can include any of the input arguments in previous syntaxes.

## Input Arguments

### **file - MATLAB file**

string

Full or partial path of the MATLAB file for which you want to generate a presentation view, specified as a string.

**Example:** 'myfile.m'

### **format - Output format of published file**

'html' (default) | 'doc' | 'latex' | 'ppt' | 'xml' | 'pdf'

Output format of published MATLAB file, specified as one of the following string values.

Output Format	String Value
Hypertext Markup Language	'html' (default)
Microsoft Word	'doc'
LaTeX	'latex'
Microsoft PowerPoint	'ppt'
Extensible Markup Language	'xml'
Portable Document Format	'pdf'

**Example:** `publish('myfile.m','ppt');`

### **options - Options for published output**

MATLAB structure

Options for published output, specified as a structure. Use the options structure instead of name-value pair arguments when you want to reuse the same configuration for publishing multiple MATLAB code files.

The `options` structure field and values correspond to names and values of the name-value pair arguments, respectively.

For example, to specify the PDF output format and the output folder `C:\myPublishedOutput`, use:

```
options = struct('format','pdf','outputDir','C:\myPublishedOutput')
```

### Name-Value Pair Arguments

Specify optional comma-separated pairs of `Name`, `Value` arguments. `Name` is the argument name and `Value` is the corresponding value. `Name` must appear inside single quotes ( ' '). You can specify several name and value pair arguments in any order as `Name1,Value1,...,NameN,ValueN`.

**Example:** `'format','latex','showCode',false` specifies LaTeX output file format and excludes the code from the output.

### Output Options

#### 'format' - Published output file format

`'html'` (default) | `'doc'` | `'latex'` | `'ppt'` | `'xml'` | `'pdf'`

Published output file format, specified as the comma-separated pair consisting of `'format'` and one of the following string values.

Output Format	String Value
Hypertext Markup Language	'html' (default)
Microsoft Word	'doc'
LaTeX	'latex'
Microsoft PowerPoint	'ppt'
Extensible Markup Language	'xml'
Portable Document Format	'pdf'

#### 'outputDir' - Output folder

`' '` (default) | full path

Output folder to which the published document is saved, specified as the comma-separated pair consisting of `'outputDir'` and the full path. You must specify the full path as a string, for example `'C:\myPublishedOutput'`.

The default value, `' '`, specifies the `html` subfolder of the current folder.

## **'stylesheet' - Extensible Stylesheet language (XSL) file**

`' '` (default) | full path to XSL file name

Extensible Stylesheet Language (XSL) file to use when publishing MATLAB code to HTML, XML, or LaTeX format, specified as the comma-separated pair consisting of `'stylesheet'` and the full path to the XSL file. The full path must be a string, for example, `'C:\myStylesheet\stylesheet.xml'`

The default value, `' '`, specifies the MATLAB default style sheet.

## **Figure Options**

### **'createThumbnail' - Thumbnail image creation**

`true` (default) | `false`

Thumbnail image creation for the published document, specified as the comma-separated pair consisting of `'createThumbnail'` and either `true` or `false`. You can use this thumbnail to represent your file in HTML pages.

### **'figureSnapMethod' - Published figure window appearance**

`'entireGUIWindow'` (default) | `'print'` | `'getframe'` | `'entireFigureWindow'`

Appearance of published figure windows, including window decorations and background color, specified as the comma-separated pair consisting of `'figureSnapMethod'` and one of the following string values.

String Value	Window Decorations		Background Color	
	GUIs	Figures	GUIs	Figures
<code>'entireGUIWindow'</code> (default)	Included	Excluded	Matches screen	White
<code>'print'</code>	Excluded	Excluded	White	White



**(Continued)**

'getframe'	Excluded	Excluded	Matches screen	Matches screen
'entireFigureWindow'	Included	Included	Matches screen	Matches screen

**'imageFormat' - Published image file format**

'png' | 'epsc2' | 'jpg' | ...

Published image file format, specified as the comma-separated pair consisting of 'imageFormat' and one of the following string values.

<b>'format' Value</b>	<b>Valid 'imageFormat' Value</b>	<b>Default 'imageFormat' Value</b>
'doc'	Any image format that your installed version of Microsoft Office can import, including 'png', 'jpg', 'bmp', and 'tiff'. If the 'figureSnapMethod' is 'print', then you can also specify 'eps', 'epsc', 'eps2', 'ill', 'meta', and 'pdf'.	'png'
'html'	Any format publishes successfully. Ensure that the tools you use to view and process the output files can display the output format you specify.	'png'

## (Continued)

'latex'	Any format publishes successfully. Ensure that the tools you use to view and process the output files can display the output format you specify.	'eps2', except when 'figureSnapMethod' is any one of the following: <ul style="list-style-type: none"><li>• 'getframe'</li><li>• 'entireFigureWindow'</li><li>• 'entireGUIWindow' and the snapped window is a GUI window</li></ul> In these cases the default is 'png'
'pdf'	'bmp' or 'jpg'.	'bmp'
'ppt'	Any format that your installed version of Microsoft Office can import, including 'png', 'jpg', 'bmp', and 'tiff'.	'png'
'xml'	Any format publishes successfully. Ensure that the tools you use to view and process the output files can display the output format you specify.	'png'

### 'maxHeight' - Maximum height of published images

[] (default) | positive integer value

Maximum height of published images that the code generates, specified as the comma-separated pair consisting of 'maxHeight' and one of the following values:

- [ ] (default)—Unrestricted height. This value is always used when the 'format' value is 'pdf'.
- Positive integer value that specifies the image height in pixels.

### **'maxWidth' - Maximum width of published images**

[ ] (default) | positive integer value

Maximum width of an image that the code generates, specified as the comma-separated pair consisting of 'maxWidth' and one of the following values:

- [ ] (default)—Unrestricted width. This value is always used when the 'format' value is 'pdf'.
- Positive integer value that specifies the image width in pixels.

### **'useNewFigure' - Create new figure**

true (default) | false

A logical value that determines if MATLAB creates a new Figure window for figures that the code generates, specified as the comma-separated pair consisting of 'useNewFigure' and one of the following:

- true (default)—If the code generates a figure, then MATLAB creates a Figure window with a white background, and at the default size before publishing.
- false—MATLAB does not create a figure window.

This value enables you to use a figure with different properties for publishing. For example, open a Figure window, change the size and background color, and then publish your code. Figures in your published document use the characteristics of the figure you opened before publishing.

## Code Options

### **'evalCode' - Option to run code**

true (default) | false

Option to evaluate code and include the MATLAB output in the published view, specified as a logical value.

### **'catchError' - Error handling during publishing**

true (default) | false

Error handling during publishing, specified as the comma-separated pair consisting of 'catchError' and one of the following logical values:

- true (default)—MATLAB continues publishing and includes the error in the published file.
- false—MATLAB displays the error at the command line and does not produce a published file.

### **'codeToEvaluate' - Additional code to evaluate during publishing**

string

Additional code to evaluate during publishing, specified as the comma-separated pair consisting of 'codeToEvaluate' and the string with the corresponding code. Use this option to specify code that does not appear in the MATLAB file, for example to set the value of an input argument for a function being published.

If this option is unspecified, MATLAB evaluates only the code in the MATLAB file you are publishing.

### **'maxOutputLines' - Maximum number of lines**

Inf (default) | nonnegative integer value

Maximum number of lines in MATLAB output per cell evaluated during publishing, specified as the comma-separated pair consisting of 'maxOutputLines' and one of the following values:

- Inf (default)—MATLAB includes all output lines in the published output.

- Nonnegative integer—MATLAB truncates the number of lines in the output at the number of lines you specify.

**'showCode' - Option to include code in published file**

true (default) | false

Option to include code in published file, specified as the comma-separated pair consisting of 'maxOutputLines' and a logical value.

**Tips**

- If 'format' is 'html', MATLAB includes the code being published at the end of the published HTML file as comments, even when you set the 'showCode' option to false. Because MATLAB includes the code as comments, this code does not display in a Web browser. This enables you to use the grabcode function to extract the MATLAB code from an HTML file, even when the file does not display the code.

**Definitions****Window Decorations**

Window decorations include window title bar, toolbar, menu bar, and window border.

**Syntax Highlighting**

Syntax highlighting colors various elements in code to help you identify these elements while reading or editing code. By default, keywords are blue, strings are purple, and unterminated strings are maroon.

MATLAB does not preserve syntax highlighting when you set 'format' to 'latex' or 'ppt'.

**Examples****Generate HTML View of MATLAB Script**

Generate an HTML view of the code, MATLAB results, and comments in a MATLAB script.

Copy the example file, fourier\_demo2.m, to your current folder.

```
copyfile(fullfile(matlabroot,'help','techdoc',...
'matlab_env','examples','fourier_demo2.m'),'.','f')
```

Generate an HTML view of the MATLAB file.

```
publish('fourier_demo2.m');
```

The `publish` command executes the code for each cell in `fourier_demo2.m`, and saves the file to `/html/fourier_demo2.html`.

View the HTML file.

```
web('html/fourier_demo2.html')
```

## **Generate View of MATLAB Script in Microsoft Word Format**

Generate a Microsoft Word view of the code, MATLAB results, and comments in a MATLAB script.

Copy the example file to your current folder.

```
copyfile(fullfile(matlabroot, 'help', 'techdoc', ...
'matlab_env', 'examples', 'fourier_demo2.m'), '.', 'f')
```

Publish the file in Microsoft Word format.

```
publish('fourier_demo2.m', 'doc');
```

View the published output.

```
winopen('html/fourier_demo2.doc')
```

## **Publish MATLAB Script Using Name-Value Pairs to Customize Output**

Generate an HTML view of the code, MATLAB results, and comments in a MATLAB script. Use name-value pair arguments to include window decorations in the published output.

Copy the example file to your current folder.

```
copyfile(fullfile(matlabroot, 'help', 'techdoc', ...
'matlab_env', 'examples', 'fourier_demo2.m'), '.', 'f')
```

Publish the example MATLAB file to HTML format.

```
publish('fourier_demo2.m', 'figureSnapMethod', 'entireFigureWindow')
```

The 'figureSnapMethod', 'entireFigureWindow' name-value pair argument specifies to include the window decorations in the figures, and to match the figure background color to the screen color.

View the published output.

```
web('html/fourier_demo2.html')
```

### **Customize publish Output Using Options Structure**

Generate a Microsoft Word view of the code, MATLAB results, and comments in a MATLAB script. Use a structure to customize the published output.

Specifying options as a structure is useful when you want to preconfigure and save your options for repeated use.

Copy the example file to your current folder.

```
copyfile(fullfile(matlabroot,'help','techdoc',...
'matlab_env','examples','fourier_demo2.m'),'.','f')
```

Define options to customize the published output as a structure, options\_doc\_nocode.

```
options_doc_nocode.format = 'doc';
options_doc_nocode.showCode = false;
```

Publish the file, specifying the options structure.

```
publish('fourier_demo2.m',options_doc_nocode);
```

### **Save File Path of Published Script to Variable**

Generate an HTML view of a MATLAB script, and save the path of the published HTML file to a variable.

This example assumes that the current folder is C:\my\_MATLAB\_files.

# publish

---

Copy the example file to your current folder.

```
copyfile(fullfile(matlabroot,'help','techdoc',...
'matlab_env','examples','fourier_demo2.m'),'.','f')
```

Publish the MATLAB file, and save the path of the resulting published HTML file to an output variable.

```
mydoc = publish('fourier_demo2.m')
```

```
mydoc =
```

```
C:\my_MATLAB_files\html\fourier_demo2.html
```

## See Also

[grabcode](#) | [notebook](#)

## Concepts

- “Publishing MATLAB Code”
- “Publishing Markup”



**Purpose** Store character array in Automation server

**Syntax** **IDL Method Signature**

```
PutCharArray([in] BSTR varname, [in] BSTR workspace,
 [in] BSTR string)
```

**Microsoft Visual Basic Client**

```
PutCharArray(varname As String, workspace As String,
 string As String)
```

**MATLAB Client**

```
h.PutCharArray('varname', 'workspace', 'string')
PutCharArray(h, 'varname', 'workspace', 'string')
```

**Description**

`h.PutCharArray('varname', 'workspace', 'string')` stores the character array in `string` in the specified workspace of the server attached to handle `h`, assigning to it the variable `varname`. The workspace argument can be either `base` or `global`. The function name is case sensitive.

`PutCharArray(h, 'varname', 'workspace', 'string')` is an alternate syntax.

**Tips**

The character array specified in the `string` argument can have any dimensions. However, `PutCharArray` changes the dimensions to a 1-by-`n` column-wise representation, where `n` is the number of characters in the array. Executing the following commands in MATLAB illustrates this behavior:

```
h = actxserver('matlab.application');
chArr = ['abc'; 'def'; 'ghk']
chArr =
abc
def
ghk
```

```
h.PutCharArray('Foo', 'base', chArr)
```

# PutCharArray

---

```
tstArr = h.GetCharArray('Foo', 'base')
tstArr =
adgbehcfk
```

## Examples

### Visual Basic .NET Client

This example uses the Visual Basic `MsgBox` command to control flow between MATLAB and the Visual Basic Client.

```
Dim Matlab As Object
Try
 Matlab = GetObject(, "matlab.application")
Catch e As Exception
 Matlab = CreateObject("matlab.application")
End Try
MsgBox("MATLAB window created; now open it...")
```

Open the MATLAB window, then click **Ok**.

```
Matlab.PutCharArray("str", "base", _
 "He jests at scars that never felt a wound.")
MsgBox("In MATLAB, type" & vbCrLf _
 & "str")
```

In the MATLAB window type `str`; MATLAB displays:

```
str =
He jests at scars that never felt a wound.
```

Click **Ok**.

```
MsgBox("closing MATLAB window...")
```

Click **Ok** to close and terminate MATLAB.

```
Matlab.Quit()
```

## See Also

[GetCharArray](#) | [PutWorkspaceData](#) | [GetWorkspaceData](#) | [Execute](#)

**Purpose** Matrix in Automation server workspace

**Syntax** **IDL Method Signature**

```
PutFullMatrix([in] BSTR varname, [in] BSTR workspace,
[in] SAFEARRAY(double) xreal, [in] SAFEARRAY(double) ximag)
```

**Microsoft Visual Basic Client**

```
PutFullMatrix([in] varname As String, [in] workspace As String,
[in] xreal As Double, [in] ximag As Double)
```

**MATLAB Client**

```
h.PutFullMatrix('varname', 'workspace', xreal, ximag)
PutFullMatrix(h, 'varname', 'workspace', xreal, ximag)
```

**Description**

`h.PutFullMatrix('varname', 'workspace', xreal, ximag)` stores a matrix in the specified workspace of the server attached to handle `h` and assigns it to variable `varname`. Use `xreal` and `ximag` for the real and imaginary parts of the matrix. The matrix cannot be a scalar, an empty array, or have more than two dimensions. The values for *workspace* are *base* or *global*.

`PutFullMatrix(h, 'varname', 'workspace', xreal, ximag)` is an alternate syntax.

For VBScript clients, use the `GetWorkspaceData` and `PutWorkspaceData` functions to pass numeric data to and from the MATLAB workspace. These functions use the variant data type instead of `safearray` which is not supported by VBScript.

**Examples**

This example uses a Visual Basic .NET client to write a matrix to the base workspace of the server:

```
Dim MatLab As Object
Dim XReal(4, 4) As Double
Dim XImag(4, 4) As Double
Dim ZReal(4, 4) As Double
Dim ZImag(4, 4) As Double
```

# PutFullMatrix

---

```
Dim i, j As Integer

For i = 0 To 4
 For j = 0 To 4
 XReal(i, j) = Rnd() * 6
 XImag(i, j) = 0
 Next j
Next i

Matlab = CreateObject("matlab.application")
MatLab.PutFullMatrix("M", "base", XReal, XImag)
MatLab.GetFullMatrix("M", "base", ZReal, ZImag)
```

---

Use a Visual Basic .NET client to write a matrix to the global workspace of the server:

```
Dim MatLab As Object
Dim XReal(1,2) As Double
Dim XImag(1,2) As Double
Dim result As String
Dim i,j As Integer

For i = 0 To 1
 For j = 0 To 2
 XReal(i,j) = (j * 2 + 1) + i
 XImag(i,j) = 1
 Next j
Next i

Matlab = CreateObject("matlab.application")
MatLab.PutFullMatrix("X", "global", XReal, XImag)
result = Matlab.Execute("whos global")
MsgBox(result)
```

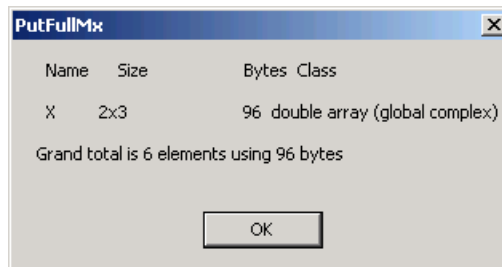

## See Also

[GetFullMatrix](#) | [PutWorkspaceData](#) | [Execute](#)

## How To

- “Exchanging Data with the Server”

# PutWorkspaceData

---

**Purpose** Data in Automation server workspace

**Syntax** **IDL Method Signature**

```
PutWorkspaceData([in] BSTR varname, [in] BSTR workspace,
[in] VARIANT data)
```

**Microsoft Visual Basic Client**

```
PutWorkspaceData(varname As String, workspace As String,
data As Object)
```

**MATLAB Client**

```
h.PutWorkspaceData('varname', 'workspace', data)
PutWorkspaceData(h, 'varname', 'workspace', data)
```

**Description**

h.PutWorkspaceData('varname', 'workspace', data) stores data in the workspace of the server attached to handle h and assigns it to varname. The values for *workspace* are base or global.

PutWorkspaceData(h, 'varname', 'workspace', data) is an alternate syntax.

Use PutWorkspaceData to pass numeric and character array data respectively to the server. Do *not* use PutWorkspaceData on sparse arrays, structures, or function handles. Use the Execute method for these data types.

The GetWorkspaceData and PutWorkspaceData functions pass numeric data as a variant data type. These functions are especially useful for VBScript clients as VBScript does not support the safearray data type used by GetFullMatrix and PutFullMatrix.

**Examples**

Create an array in a Visual Basic .NET client and put it in the base workspace of the MATLAB Automation server:

- 1 Create the Visual Basic application. Use the MsgBox command to control flow between MATLAB and the application:

```
Dim Matlab As Object
```

```
Dim data(6) As Double
Dim i As Integer
MatLab = CreateObject("matlab.application")
For i = 0 To 6
 data(i) = i * 15
Next i
MatLab.PutWorkspaceData("A","base",data)
MsgBox("In MATLAB, type" & vbCrLf & "A")
```

**2** Open the MATLAB window and type A. MATLAB displays:

```
A =
 0 15 30 45 60 75 90
```

**3** Click **Ok** to close and terminate MATLAB.

## See Also

[GetWorkspaceData](#) | [PutFullMatrix](#) | [PutCharArray](#) | [Execute](#)

## How To

- “Executing Commands in the MATLAB Server”
- “Exchanging Data with the Server”

# pwd

---

**Purpose** Identify current folder

**Syntax** `pwd`  
`currentFolder = pwd`

**Description** `pwd` displays the MATLAB current folder.  
`currentFolder = pwd` returns the current folder as a string to `currentFolder`.

**Alternatives**

- Use the Current Folder toolbar.

**See Also** `cd` | `dir`



**Purpose** Quasi-minimal residual method

**Syntax**

```
x = qmr(A,b)
qmr(A,b,tol)
qmr(A,b,tol,maxit)
qmr(A,b,tol,maxit,M)
qmr(A,b,tol,maxit,M1,M2)
qmr(A,b,tol,maxit,M1,M2,x0)
[x,flag] = qmr(A,b,...)
[x,flag,relres] = qmr(A,b,...)
[x,flag,relres,iter] = qmr(A,b,...)
[x,flag,relres,iter,resvec] = qmr(A,b,...)
```

**Description** `x = qmr(A,b)` attempts to solve the system of linear equations  $A*x=b$  for  $x$ . The  $n$ -by- $n$  coefficient matrix  $A$  must be square and should be large and sparse. The column vector  $b$  must have length  $n$ . You can specify  $A$  as a function handle, `afun`, such that `afun(x, 'notransp')` returns  $A*x$  and `afun(x, 'transp')` returns  $A'*x$ .

“Parameterizing Functions” explains how to provide additional parameters to the function `afun`, as well as the preconditioner function `mfun` described below, if necessary.

If `qmr` converges, a message to that effect is displayed. If `qmr` fails to converge after the maximum number of iterations or halts for any reason, a warning message is printed displaying the relative residual  $\text{norm}(b-A*x)/\text{norm}(b)$  and the iteration number at which the method stopped or failed.

`qmr(A,b,tol)` specifies the tolerance of the method. If `tol` is `[]`, then `qmr` uses the default,  $1e-6$ .

`qmr(A,b,tol,maxit)` specifies the maximum number of iterations. If `maxit` is `[]`, then `qmr` uses the default,  $\min(n,20)$ .

`qmr(A,b,tol,maxit,M)` and `qmr(A,b,tol,maxit,M1,M2)` use preconditioners  $M$  or  $M = M1*M2$  and effectively solve the system  $\text{inv}(M)*A*x = \text{inv}(M)*b$  for  $x$ . If  $M$  is `[]` then `qmr` applies no

preconditioner.  $M$  can be a function handle  $mfun$  such that  $mfun(x, 'notransp')$  returns  $M \setminus x$  and  $mfun(x, 'transp')$  returns  $M' \setminus x$ .

`qmr(A,b,tol,maxit,M1,M2,x0)` specifies the initial guess. If  $x0$  is `[]`, then `qmr` uses the default, an all zero vector.

`[x,flag] = qmr(A,b,...)` also returns a convergence flag.

Flag	Convergence
0	<code>qmr</code> converged to the desired tolerance <code>tol</code> within <code>maxit</code> iterations.
1	<code>qmr</code> iterated <code>maxit</code> times but did not converge.
2	Preconditioner $M$ was ill-conditioned.
3	The method stagnated. (Two consecutive iterates were the same.)
4	One of the scalar quantities calculated during <code>qmr</code> became too small or too large to continue computing.

Whenever `flag` is not 0, the solution  $x$  returned is that with minimal norm residual computed over all the iterations. No messages are displayed if the `flag` output is specified.

`[x,flag,relres] = qmr(A,b,...)` also returns the relative residual norm  $\|b - A \cdot x\| / \|b\|$ . If `flag` is 0, `relres`  $\leq$  `tol`.

`[x,flag,relres,iter] = qmr(A,b,...)` also returns the iteration number at which  $x$  was computed, where  $0 \leq \text{iter} \leq \text{maxit}$ .

`[x,flag,relres,iter,resvec] = qmr(A,b,...)` also returns a vector of the residual norms at each iteration, including  $\|b - A \cdot x_0\|$ .

## Examples

### Using `qmr` with a Matrix Input

This example shows how to use `qmr` with a matrix input. The code:

```
n = 100;
on = ones(n,1);
```

```

A = spdiags([-2*on 4*on -on],-1:1,n,n);
b = sum(A,2);
tol = 1e-8; maxit = 15;
M1 = spdiags([on/(-2) on],-1:0,n,n);
M2 = spdiags([4*on -on],0:1,n,n);
x = qmr(A,b,tol,maxit,M1,M2);

```

displays the message:

```

qmr converged at iteration 9 to a solution...
with relative residual
5.6e-009

```

### Using qmr with a Function Handle

This example replaces the matrix A in the previous example with a handle to a matrix-vector product function `afun`. The example is contained in a file `run_qmr` that

- Calls `qmr` with the function handle `@afun` as its first argument.
- Contains `afun` as a nested function, so that all variables in `run_qmr` are available to `afun`.

The following shows the code for `run_qmr`:

```

function x1 = run_qmr
n = 100;
on = ones(n,1);
A = spdiags([-2*on 4*on -on],-1:1,n,n);
b = sum(A,2);
tol = 1e-8;
maxit = 15;
M1 = spdiags([on/(-2) on],-1:0,n,n);
M2 = spdiags([4*on -on],0:1,n,n);
x1 = qmr(@afun,b,tol,maxit,M1,M2);

function y = afun(x,transp_flag)
 if strcmp(transp_flag,'transp')
 y = 4 * x;
 % y = A'*x

```

```
 y(1:n-1) = y(1:n-1) - 2 * x(2:n);
 y(2:n) = y(2:n) - x(1:n-1);
 elseif strcmp(transp_flag,'notransp') % y = A*x
 y = 4 * x;
 y(2:n) = y(2:n) - 2 * x(1:n-1);
 y(1:n-1) = y(1:n-1) - x(2:n);
 end
end
end
```

When you enter

```
x1=run_qmr;
```

MATLAB software displays the message

```
qmr converged at iteration 9 to a solution with relative residual
5.6e-009
```

### **Using qmr with a Preconditioner**

This example demonstrates the use of a preconditioner.

Load A = west0479, a real 479-by-479 nonsymmetric sparse matrix.

```
load west0479;
A = west0479;
```

Define b so that the true solution is a vector of all ones.

```
b = full(sum(A,2));
```

Set the tolerance and maximum number of iterations.

```
tol = 1e-12; maxit = 20;
```

Use qmr to find a solution at the requested tolerance and number of iterations.

```
[x0,f10,rr0,it0,rv0] = qmr(A,b,tol,maxit);
```

`f10` is 1 because `qmr` does not converge to the requested tolerance  $1e-12$  within the requested 20 iterations. The seventeenth iterate is the best approximate solution and is the one returned as indicated by `it0 = 17`. MATLAB stores the residual history in `rv0`.

Plot the behavior of `qmr`.

```
semilogy(0:maxit,rv0/norm(b),'-o');
xlabel('Iteration number');
ylabel('Relative residual');
```

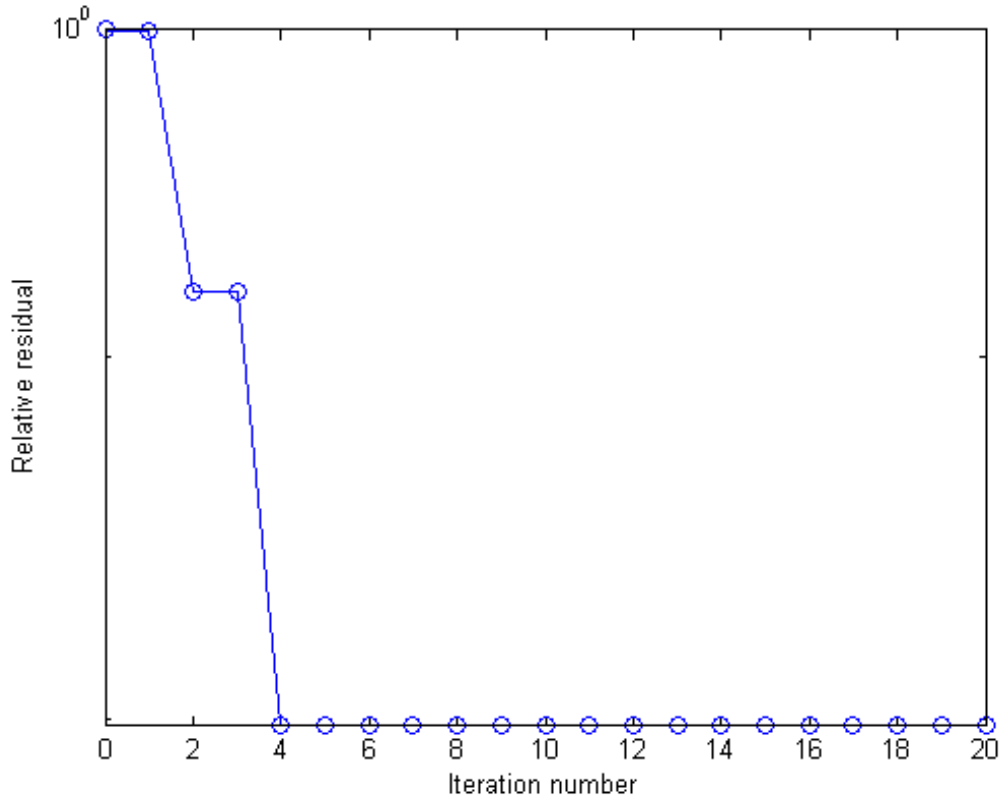

The plot shows that the solution does not converge. You can use a preconditioner to improve the outcome.

Create the preconditioner with `ilu`, since the matrix `A` is nonsymmetric.

```
[L,U] = ilu(A,struct('type','ilutp','droptol',1e-5));
```

Error using `ilu`

There is a pivot equal to zero. Consider decreasing the drop tolerance or consider using the `'udiag'` option.

MATLAB cannot construct the incomplete LU as it would result in a singular factor, which is useless as a preconditioner.

You can try again with a reduced drop tolerance, as indicated by the error message.

```
[L,U] = ilu(A,struct('type','ilutp','droptol',1e-6));
[x1,f11,rr1,it1,rv1] = qmr(A,b,tol,maxit,L,U);
```

f11 is 0 because qmr drives the relative residual to  $4.1410e-014$  (the value of rr1). The relative residual is less than the prescribed tolerance of  $1e-12$  at the sixth iteration (the value of it1) when preconditioned by the incomplete LU factorization with a drop tolerance of  $1e-6$ . The output rv1(1) is norm(b), and the output rv1(7) is norm(b-A\*x2).

You can follow the progress of qmr by plotting the relative residuals at each iteration starting from the initial estimate (iterate number 0).

```
semilogy(0:it1,rv1/norm(b),'-o');
xlabel('Iteration number');
ylabel('Relative residual');
```

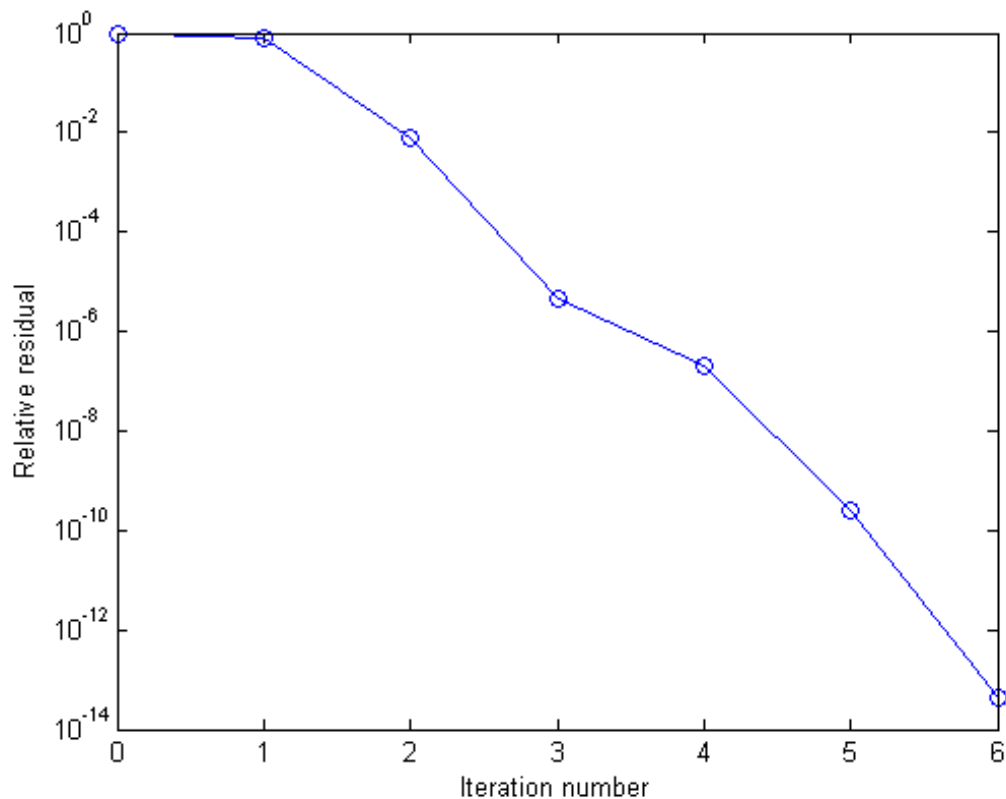

## References

[1] Barrett, R., M. Berry, T. F. Chan, et al., *Templates for the Solution of Linear Systems: Building Blocks for Iterative Methods*, SIAM, Philadelphia, 1994.

[2] Freund, Roland W. and Noël M. Nachtigal, "QMR: A quasi-minimal residual method for non-Hermitian linear systems," *SIAM Journal: Numer. Math.* 60, 1991, pp. 315–339.



**See Also**

`bicg` | `bicgstab` | `cgs` | `function_handle` | `gmres` | `lsqr` | `ilu` |  
`minres` | `pcg` | `symmlq` | `mldivide`

**Purpose** Orthogonal-triangular decomposition

**Syntax**

```
[Q,R] = qr(A)
[Q,R] = qr(A,0)
[Q,R,E] = qr(A)
[Q,R,E] = qr(A,'matrix')
[Q,R,e] = qr(A,'vector')
[Q,R,e] = qr(A,0)
X = qr(A)
X = qr(A,0)
R = qr(A)
R = qr(A,0)
[C,R] = qr(A,B)
[C,R,E] = qr(A,B)
[C,R,E] = qr(A,B,'matrix')
[C,R,e] = qr(A,B,'vector')
[C,R] = qr(A,B,0)
[C,R,e] = qr(A,B,0)
```

**Description**  $[Q,R] = \text{qr}(A)$ , where  $A$  is  $m$ -by- $n$ , produces an  $m$ -by- $n$  upper triangular matrix  $R$  and an  $m$ -by- $m$  unitary matrix  $Q$  so that  $A = Q \cdot R$ .

$[Q,R] = \text{qr}(A,0)$  produces the economy-size decomposition. If  $m > n$ , only the first  $n$  columns of  $Q$  and the first  $n$  rows of  $R$  are computed. If  $m \leq n$ , this is the same as  $[Q,R] = \text{qr}(A)$ .

If  $A$  is full:

$[Q,R,E] = \text{qr}(A)$  or  $[Q,R,E] = \text{qr}(A, 'matrix')$  produces unitary  $Q$ , upper triangular  $R$  and a permutation matrix  $E$  so that  $A \cdot E = Q \cdot R$ . The column permutation  $E$  is chosen so that  $\text{abs}(\text{diag}(R))$  is decreasing.

$[Q,R,e] = \text{qr}(A, 'vector')$  returns the permutation information as a vector instead of a matrix. That is,  $e$  is a row vector such that  $A(:, e) = Q \cdot R$ .

$[Q,R,e] = \text{qr}(A,0)$  produces an economy-size decomposition in which  $e$  is a permutation vector, so that  $A(:, e) = Q \cdot R$ .

$X = \text{qr}(A)$  and  $X = \text{qr}(A,0)$  return a matrix  $X$  such that  $\text{triu}(X)$  is the upper triangular factor  $R$ .

If  $A$  is sparse:

$R = \text{qr}(A)$  computes a Q-less QR decomposition and returns the upper triangular factor  $R$ . Note that  $R = \text{chol}(A' * A)$ . Since  $Q$  is often nearly full, this is preferred to  $[Q,R] = \text{QR}(A)$ .

$R = \text{qr}(A,0)$  produces economy-size  $R$ . If  $m > n$ ,  $R$  has only  $n$  rows. If  $m \leq n$ , this is the same as  $R = \text{qr}(A)$ .

$[Q,R,E] = \text{qr}(A)$  or  $[Q,R,E] = \text{qr}(A, 'matrix')$  produces unitary  $Q$ , upper triangular  $R$  and a permutation matrix  $E$  so that  $A * E = Q * R$ . The column permutation  $E$  is chosen to reduce fill-in in  $R$ .

$[Q,R,e] = \text{qr}(A, 'vector')$  returns the permutation information as a vector instead of a matrix. That is,  $e$  is a row vector such that  $A(:, e) = Q * R$ .

$[Q,R,e] = \text{qr}(A,0)$  produces an economy-size decomposition in which  $e$  is a permutation vector, so that  $A(:, e) = Q * R$ .

$[C,R] = \text{qr}(A,B)$ , where  $B$  has as many rows as  $A$ , returns  $C = Q' * B$ . The least-squares solution to  $A * X = B$  is  $X = R \setminus C$ .

$[C,R,E] = \text{qr}(A,B)$  or  $[C,R,E] = \text{qr}(A,B, 'matrix')$ , also returns a fill-reducing ordering. The least-squares solution to  $A * X = B$  is  $X = E * (R \setminus C)$ .

$[C,R,e] = \text{qr}(A,B, 'vector')$  returns the permutation information as a vector instead of a matrix. That is, the least-squares solution to  $A * X = B$  is  $X(e, :) = R \setminus C$ .

$[C,R] = \text{qr}(A,B,0)$  produces economy-size results. If  $m > n$ ,  $C$  and  $R$  have only  $n$  rows. If  $m \leq n$ , this is the same as  $[C,R] = \text{qr}(A,B)$ .

$[C,R,e] = \text{qr}(A,B,0)$  additionally produces a fill-reducing permutation vector  $e$ . In this case, the least-squares solution to  $A * X = B$  is  $X(e, :) = R \setminus C$ .

## Examples

Find the least squares approximate solution to  $A*x = b$  with the Q-less QR decomposition and one step of iterative refinement:

```
if issparse(A), R = qr(A);
else R = triu(qr(A)); end
x = R\(R\'\'(A'*b));
r = b - A*x;
err = R\'\'(A'*r);
x = x + err;
```

## See Also

[lu](#) | [chol](#) | [null](#) | [orth](#) | [qrdelete](#) | [qrinsert](#) | [qrupdate](#)

**Purpose** Remove column or row from QR factorization

**Syntax**

```
[Q1,R1] = qrdelete(Q,R,j)
[Q1,R1] = qrdelete(Q,R,j,'col')
[Q1,R1] = qrdelete(Q,R,j,'row')
```

**Description**

`[Q1,R1] = qrdelete(Q,R,j)` returns the QR factorization of the matrix `A1`, where `A1` is `A` with the column `A(:,j)` removed and `[Q,R] = qr(A)` is the QR factorization of `A`.

`[Q1,R1] = qrdelete(Q,R,j,'col')` is the same as `qrdelete(Q,R,j)`.

`[Q1,R1] = qrdelete(Q,R,j,'row')` returns the QR factorization of the matrix `A1`, where `A1` is `A` with the row `A(j,:)` removed and `[Q,R] = qr(A)` is the QR factorization of `A`.

**Examples**

```
A = magic(5);
[Q,R] = qr(A);
j = 3;
[Q1,R1] = qrdelete(Q,R,j,'row');
```

```
Q1 =
 0.5274 -0.5197 -0.6697 -0.0578
 0.7135 0.6911 0.0158 0.1142
 0.3102 -0.1982 0.4675 -0.8037
 0.3413 -0.4616 0.5768 0.5811
```

```
R1 =
 32.2335 26.0908 19.9482 21.4063 23.3297
 0 -19.7045 -10.9891 0.4318 -1.4873
 0 0 22.7444 5.8357 -3.1977
 0 0 0 -14.5784 3.7796
```

returns a valid QR factorization, although possibly different from

```
A2 = A;
A2(j,:) = [];
[Q2,R2] = qr(A2)
```

# qrdelete

---

```
Q2 =
 -0.5274 0.5197 0.6697 -0.0578
 -0.7135 -0.6911 -0.0158 0.1142
 -0.3102 0.1982 -0.4675 -0.8037
 -0.3413 0.4616 -0.5768 0.5811
```

```
R2 =
 -32.2335 -26.0908 -19.9482 -21.4063 -23.3297
 0 19.7045 10.9891 -0.4318 1.4873
 0 0 -22.7444 -5.8357 3.1977
 0 0 0 -14.5784 3.7796
```

## Algorithms

The `qrdelete` function uses a series of Givens rotations to zero out the appropriate elements of the factorization.

## See Also

`planerot` | `qr` | `qrinsert`

**Purpose** Insert column or row into QR factorization

**Syntax**

```
[Q1,R1] = qrinsert(Q,R,j,x)
[Q1,R1] = qrinsert(Q,R,j,x,'col')
[Q1,R1] = qrinsert(Q,R,j,x,'row')
```

**Description** [Q1,R1] = qrinsert(Q,R,j,x) returns the QR factorization of the matrix A1, where A1 is  $A = Q \cdot R$  with the column x inserted before  $A(:,j)$ . If A has n columns and  $j = n+1$ , then x is inserted after the last column of A.

[Q1,R1] = qrinsert(Q,R,j,x,'col') is the same as qrinsert(Q,R,j,x).

[Q1,R1] = qrinsert(Q,R,j,x,'row') returns the QR factorization of the matrix A1, where A1 is  $A = Q \cdot R$  with an extra row, x, inserted before  $A(j,:)$ .

## Examples

```
A = magic(5);
[Q,R] = qr(A);
j = 3;
x = 1:5;
[Q1,R1] = qrinsert(Q,R,j,x,'row')
```

```
Q1 =
 0.5231 0.5039 -0.6750 0.1205 0.0411 0.0225
 0.7078 -0.6966 0.0190 -0.0788 0.0833 -0.0150
 0.0308 0.0592 0.0656 0.1169 0.1527 -0.9769
 0.1231 0.1363 0.3542 0.6222 0.6398 0.2104
 0.3077 0.1902 0.4100 0.4161 -0.7264 -0.0150
 0.3385 0.4500 0.4961 -0.6366 0.1761 0.0225
```

```
R1 =
 32.4962 26.6801 21.4795 23.8182 26.0031
 0 19.9292 12.4403 2.1340 4.3271
 0 0 24.4514 11.8132 3.9931
 0 0 0 20.2382 10.3392
```

# qrinsert

---

```
0 0 0 0 16.1948
0 0 0 0 0
```

returns a valid QR factorization, although possibly different from

```
A2 = [A(1:j-1,:); x; A(j:end,:)];
[Q2,R2] = qr(A2)
```

```
Q2 =
-0.5231 0.5039 0.6750 -0.1205 0.0411 0.0225
-0.7078 -0.6966 -0.0190 0.0788 0.0833 -0.0150
-0.0308 0.0592 -0.0656 -0.1169 0.1527 -0.9769
-0.1231 0.1363 -0.3542 -0.6222 0.6398 0.2104
-0.3077 0.1902 -0.4100 -0.4161 -0.7264 -0.0150
-0.3385 0.4500 -0.4961 0.6366 0.1761 0.0225
```

```
R2 =
-32.4962 -26.6801 -21.4795 -23.8182 -26.0031
 0 19.9292 12.4403 2.1340 4.3271
 0 0 -24.4514 -11.8132 -3.9931
 0 0 0 -20.2382 -10.3392
 0 0 0 0 16.1948
 0 0 0 0 0
```

## Algorithms

The `qrinsert` function inserts the values of `x` into the `j`th column (row) of `R`. It then uses a series of Givens rotations to zero out the nonzero elements of `R` on and below the diagonal in the `j`th column (row).

## See Also

`planerot` | `qr` | `qrdelete`



**Purpose** Rank 1 update to QR factorization

**Syntax** `[Q1,R1] = qrupdate(Q,R,u,v)`

**Description** `[Q1,R1] = qrupdate(Q,R,u,v)` when `[Q,R] = qr(A)` is the original QR factorization of A, returns the QR factorization of  $A + u \cdot v'$ , where u and v are column vectors of appropriate lengths.

**Tips** qrupdate works only for full matrices.

**Examples** The matrix

```
mu = sqrt(eps)
```

```
mu =
```

```
1.4901e-08
```

```
A = [ones(1,4); mu*eye(4)];
```

is a well-known example in least squares that indicates the dangers of forming  $A' \cdot A$ . Instead, we work with the QR factorization – orthonormal Q and upper triangular R.

```
[Q,R] = qr(A);
```

As we expect, R is upper triangular.

```
R =
```

```
-1.0000 -1.0000 -1.0000 -1.0000
 0 0.0000 0.0000 0.0000
 0 0 0.0000 0.0000
 0 0 0 0.0000
 0 0 0 0
```

# qrupdate

---

In this case, the upper triangular entries of R, excluding the first row, are on the order of  $\sqrt{\text{eps}}$ .

Consider the update vectors

$$u = [-1 \ 0 \ 0 \ 0 \ 0]'; \quad v = \text{ones}(4,1);$$

Instead of computing the rather trivial QR factorization of this rank one update to A from scratch with

$$[QT,RT] = \text{qr}(A + u*v')$$

QT =

$$\begin{bmatrix} 0 & 0 & 0 & 0 & 1 \\ -1 & 0 & 0 & 0 & 0 \\ 0 & -1 & 0 & 0 & 0 \\ 0 & 0 & -1 & 0 & 0 \\ 0 & 0 & 0 & -1 & 0 \end{bmatrix}$$

RT =

$$1.0\text{e-}007 * \begin{bmatrix} -0.1490 & 0 & 0 & 0 \\ 0 & -0.1490 & 0 & 0 \\ 0 & 0 & -0.1490 & 0 \\ 0 & 0 & 0 & -0.1490 \\ 0 & 0 & 0 & 0 \end{bmatrix}$$

we may use `qrupdate`.

$$[Q1,R1] = \text{qrupdate}(Q,R,u,v)$$

Q1 =

$$\begin{bmatrix} -0.0000 & -0.0000 & -0.0000 & -0.0000 & 1.0000 \\ 1.0000 & -0.0000 & -0.0000 & -0.0000 & 0.0000 \end{bmatrix}$$

```

 0.0000 1.0000 -0.0000 -0.0000 0.0000
 0.0000 0.0000 1.0000 -0.0000 0.0000
 -0.0000 -0.0000 -0.0000 1.0000 0.0000

```

R1 =

```

1.0e-007 *
0.1490 0.0000 0.0000 0.0000
 0 0.1490 0.0000 0.0000
 0 0 0.1490 0.0000
 0 0 0 0.1490
 0 0 0 0

```

Note that both factorizations are correct, even though they are different.

## Algorithms

qrupdate uses the algorithm in section 12.5.1 of the third edition of *Matrix Computations* by Golub and van Loan. qrupdate is useful since, if we take  $N = \max(m, n)$ , then computing the new QR factorization from scratch is roughly an  $O(N^3)$  algorithm, while simply updating the existing factors in this way is an  $O(N^2)$  algorithm.

## References

[1] Golub, Gene H. and Charles Van Loan, *Matrix Computations*, Third Edition, Johns Hopkins University Press, Baltimore, 1996

## See Also

cholupdate | qr

# quad

---

**Purpose** Numerically evaluate integral, adaptive Simpson quadrature

**Compatibility** quad will be removed in a future release. Use `integral` instead.

**Syntax**

```
q = quad(fun,a,b)
q = quad(fun,a,b,tol)
q = quad(fun,a,b,tol,trace)
[q,fcnt] = quad(...)
```

**Description** *Quadrature* is a numerical method used to find the area under the graph of a function, that is, to compute a definite integral.

$$q = \int_a^b f(x) dx$$

`q = quad(fun,a,b)` tries to approximate the integral of function `fun` from `a` to `b` to within an error of `1e-6` using recursive adaptive Simpson quadrature. `fun` is a function handle. Limits `a` and `b` must be finite. The function `y = fun(x)` should accept a vector argument `x` and return a vector result `y`, the integrand evaluated at each element of `x`.

“Parameterizing Functions” explains how to provide additional parameters to the function `fun`, if necessary.

`q = quad(fun,a,b,tol)` uses an absolute error tolerance `tol` instead of the default which is `1.0e-6`. Larger values of `tol` result in fewer function evaluations and faster computation, but less accurate results. In MATLAB version 5.3 and earlier, the `quad` function used a less reliable algorithm and a default relative tolerance of `1.0e-3`.

`q = quad(fun,a,b,tol,trace)` with non-zero `trace` shows the values of `[fcnt a b-a Q]` during the recursion.

`[q,fcnt] = quad(...)` returns the number of function evaluations.

The function `quadl` may be more efficient with high accuracies and smooth integrands.

The list below contains information to help you determine which quadrature function in MATLAB to use:

- The `quad` function may be most efficient for low accuracies with nonsmooth integrands.
- The `quadl` function may be more efficient than `quad` at higher accuracies with smooth integrands.
- The `quadgk` function may be most efficient for high accuracies and oscillatory integrands. It supports infinite intervals and can handle moderate singularities at the endpoints. It also supports contour integration along piecewise linear paths.
- The `quadv` function vectorizes `quad` for an array-valued `fun`.
- If the interval is infinite,  $[a, \text{Inf})$ , then for the integral of `fun(x)` to exist, `fun(x)` must decay as `x` approaches infinity, and `quadgk` requires it to decay rapidly. Special methods should be used for oscillatory functions on infinite intervals, but `quadgk` can be used if `fun(x)` decays fast enough.
- The `quadgk` function will integrate functions that are singular at finite endpoints if the singularities are not too strong. For example, it will integrate functions that behave at an endpoint `c` like  $\log|x-c|$  or  $|x-c|^p$  for  $p \geq -1/2$ . If the function is singular at points inside  $(a,b)$ , write the integral as a sum of integrals over subintervals with the singular points as endpoints, compute them with `quadgk`, and add the results.

## Examples

To compute the integral

$$\int_0^2 \frac{1}{x^3 - 2x - 5} dx,$$

write a function `myfun` that computes the integrand:

```
function y = myfun(x)
y = 1./(x.^3-2*x-5);
```

# quad

---

Then pass `@myfun`, a function handle to `myfun`, to `quad`, along with the limits of integration, 0 to 2:

```
Q = quad(@myfun,0,2)
```

```
Q =
```

```
-0.4605
```

Alternatively, you can pass the integrand to `quad` as an anonymous function handle `F`:

```
F = @(x)1./(x.^3-2*x-5);
```

```
Q = quad(F,0,2);
```

## Algorithms

`quad` implements a low order method using an adaptive recursive Simpson's rule.

## Diagnostics

`quad` may issue one of the following warnings:

'Minimum step size reached' indicates that the recursive interval subdivision has produced a subinterval whose length is on the order of roundoff error in the length of the original interval. A nonintegrable singularity is possible.

'Maximum function count exceeded' indicates that the integrand has been evaluated more than 10,000 times. A nonintegrable singularity is likely.

'Infinite or Not-a-Number function value encountered' indicates a floating point overflow or division by zero during the evaluation of the integrand in the interior of the interval.

## References

[1] Gander, W. and W. Gautschi, "Adaptive Quadrature – Revisited," BIT, Vol. 40, 2000, pp. 84-101. This document is also available at <http://www.inf.ethz.ch/personal/gander>.

## See Also

`quad2d` | `dblquad` | `quadgk` | `quadl` | `quadv` | `trapz` | `triplequad` | `function_handle` | `integral` | `integral2` | `integral3`

**How To**

- “Anonymous Functions”

# quad2d

---

**Purpose** Numerically evaluate double integral, tiled method

**Syntax**  
`q = quad2d(fun,a,b,c,d)`  
`[q,errbnd] = quad2d(...)`  
`q = quad2d(fun,a,b,c,d,param1,val1,param2,val2,...)`

**Description** `q = quad2d(fun,a,b,c,d)` approximates the integral of `fun(x,y)` over the planar region  $a \leq x \leq b$  and  $c(x) \leq y \leq d(x)$ . `fun` is a function handle, `c` and `d` may each be a scalar or a function handle. All input functions must be vectorized. The function `Z=fun(X,Y)` must accept 2-D matrices `X` and `Y` of the same size and return a matrix `Z` of corresponding values. The functions `ymin=c(X)` and `ymax=d(X)` must accept matrices and return matrices of the same size with corresponding values.

`[q,errbnd] = quad2d(...)`. `errbnd` is an approximate upper bound on the absolute error,  $|Q - I|$ , where `I` denotes the exact value of the integral.

`q = quad2d(fun,a,b,c,d,param1,val1,param2,val2,...)` performs the integration as above with specified values of optional parameters:

<code>AbsTol</code>	absolute error tolerance
<code>RelTol</code>	relative error tolerance

`quad2d` attempts to satisfy  $ERRBND \leq \max(AbsTol, RelTol * |Q|)$ . This is absolute error control when  $|Q|$  is sufficiently small and relative error control when  $|Q|$  is larger. A default tolerance value is used when a tolerance is not specified. The default value of `AbsTol` is  $1e-5$ . The default value of `RelTol` is  $100 * \text{eps}(\text{class}(Q))$ . This is also the minimum value of `RelTol`. Smaller `RelTol` values are automatically increased to the default value.

<code>MaxFunEvals</code>	Maximum allowed number of evaluations of <code>fun</code> reached.
--------------------------	--------------------------------------------------------------------



The `MaxFunEvals` parameter limits the number of vectorized calls to `fun`. The default is 2000.

<code>FailurePlot</code>	Generate a plot if <code>MaxFunEvals</code> is reached.
--------------------------	---------------------------------------------------------

Setting `FailurePlot` to `true` generates a graphical representation of the regions needing further refinement when `MaxFunEvals` is reached. No plot is generated if the integration succeeds before reaching `MaxFunEvals`. These (generally) 4-sided regions are mapped to rectangles internally. Clusters of small regions indicate the areas of difficulty. The default is `false`.

<code>Singular</code>	Problem may have boundary singularities
-----------------------	-----------------------------------------

With `Singular` set to `true`, `quad2d` will employ transformations to weaken boundary singularities for better performance. The default is `true`. Setting `Singular` to `false` will turn these transformations off, which may provide a performance benefit on some smooth problems.

## Examples

### Example 1

Integrate  $y\sin(x) + x\cos(y)$  over  $\pi \leq x \leq 2\pi$ ,  $0 \leq y \leq \pi$ . The true value of the integral is  $-\pi^2$ .

```
Q = quad2d(@(x,y) y.*sin(x)+x.*cos(y),pi,2*pi,0,pi)
```

### Example 2

Integrate  $[(x+y)^{1/2}(1+x+y)^2]^{-1}$  over the triangle  $0 \leq x \leq 1$  and  $0 \leq y \leq 1-x$ . The integrand is infinite at  $(0,0)$ . The true value of the integral is  $\pi/4 - 1/2$ .

```
fun = @(x,y) 1./(sqrt(x + y) .* (1 + x + y).^2)
```

In Cartesian coordinates:

```
ymax = @(x) 1 - x;
```

# quad2d

---

```
Q = quad2d(fun,0,1,0,ymax)
```

In polar coordinates:

```
polarfun = @(theta,r) fun(r.*cos(theta),r.*sin(theta)).*r;
rmax = @(theta) 1./(sin(theta) + cos(theta));
Q = quad2d(polarfun,0,pi/2,0,rmax)
```

## Limitations

quad2d begins by mapping the region of integration to a rectangle. Consequently, it may have trouble integrating over a region that does not have four sides or has a side that cannot be mapped smoothly to a straight line. If the integration is unsuccessful, some helpful tactics are leaving `Singular` set to its default value of `true`, changing between Cartesian and polar coordinates, or breaking the region of integration into pieces and adding the results of integration over the pieces.

For instance:

```
fun = @(x,y)abs(x.^2 + y.^2 - 0.25);
c = @(x)-sqrt(1 - x.^2);
d = @(x)sqrt(1 - x.^2);
quad2d(fun,-1,1,c,d,'AbsTol',1e-8,...
 'FailurePlot',true,'Singular',false);
```

Warning: Reached the maximum number of function evaluations (2000). The r fails the global error test.

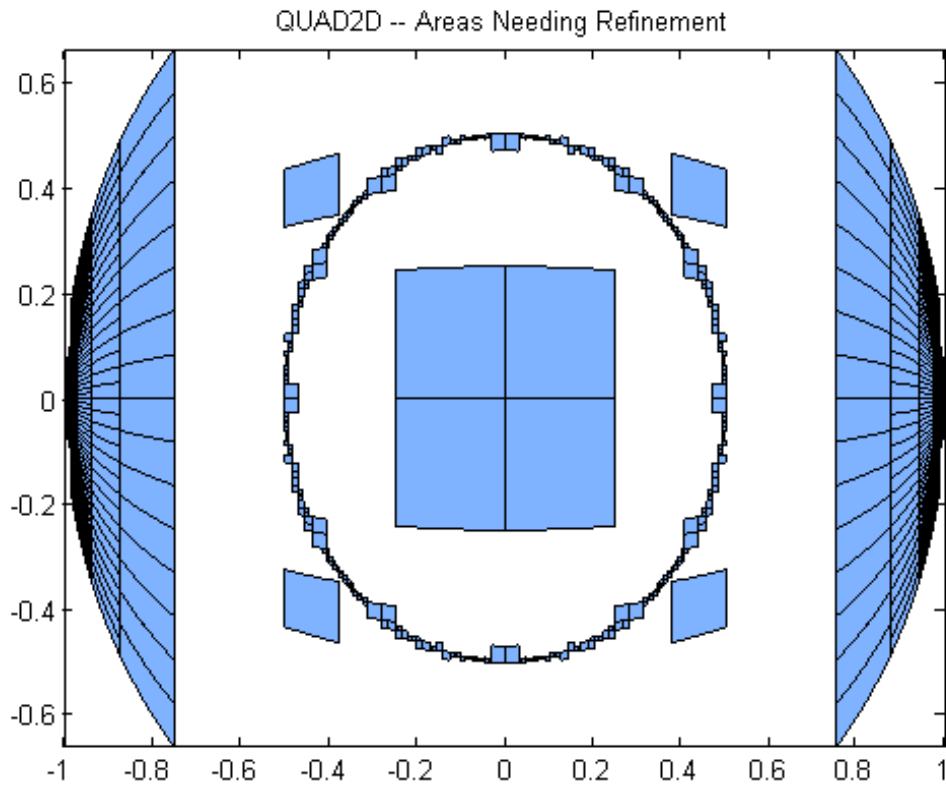

The failure plot shows two areas of difficulty, near the points  $(-1, 0)$  and  $(1, 0)$  and near the circle  $x^2 + y^2 = 0.25$ .

Changing the value of `Singular` to `true` will cope with the geometric singularities at  $(-1, 0)$  and  $(1, 0)$ . The larger shaded areas may need refinement but are probably not areas of difficulty.

```
Q = quad2d(fun, -1, 1, c, d, 'AbsTol', 1e-8, ...
 'FailurePlot', true, 'Singular', true);
```

# quad2d

Warning: Reached the maximum number of function evaluations (2000). The result passes the global error test.

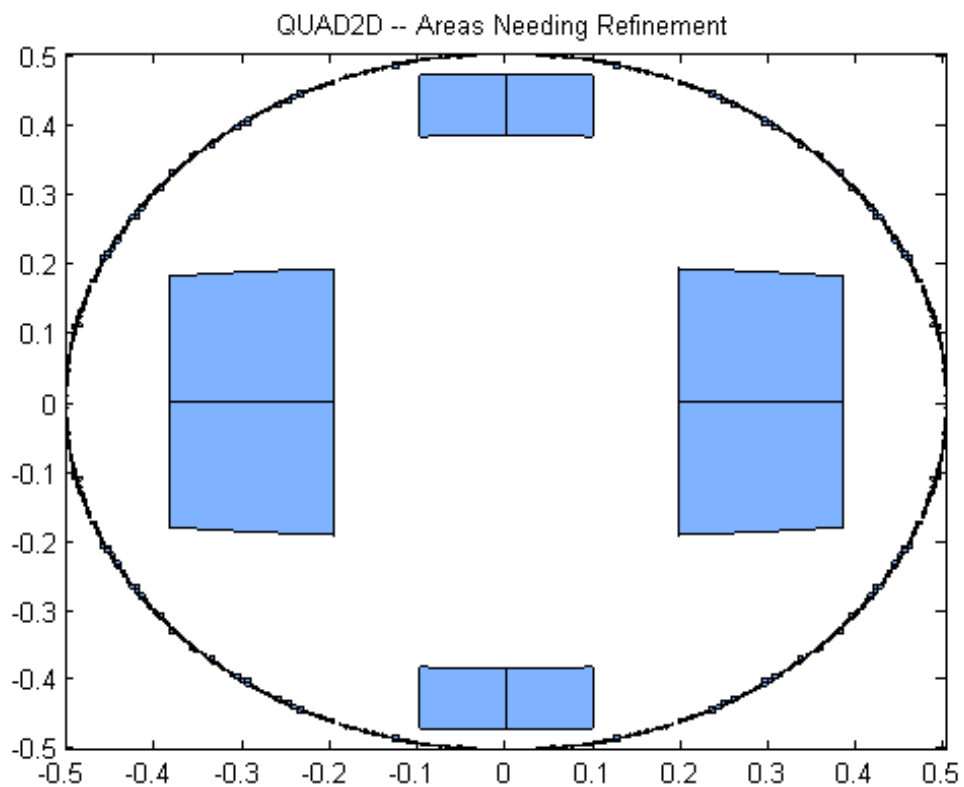

From here you can take advantage of symmetry:

```
Q = 4*quad2d(fun,0,1,0,d,'Abstol',1e-8,...
 'Singular',true,'FailurePlot',true)
```

Q =

0.9817

However, the code is still working very hard near the singularity. It may not be able to provide higher accuracy:

```
Q = 4*quad2d(fun,0,1,0,d,'Abstol',1e-10,...
 'Singular',true,'FailurePlot',true);
```

Warning: Reached the maximum number of function evaluations (2000). The result does not pass the global error test.

# quad2d

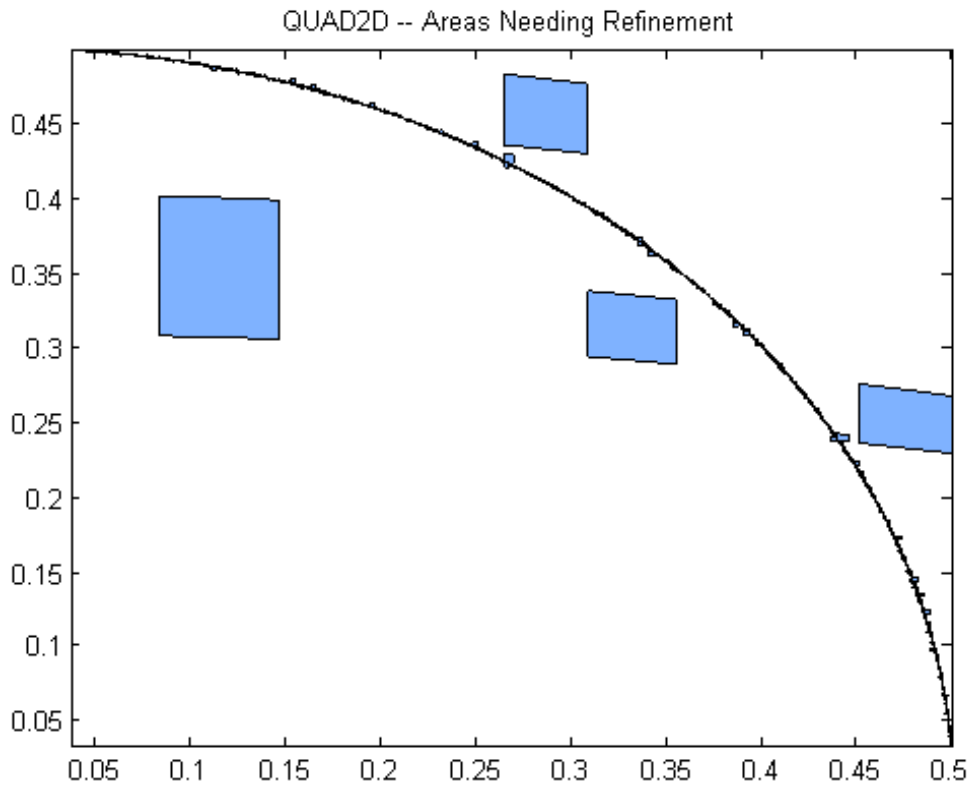

At higher accuracy, a change in coordinates may work better.

```
polarfun = @(theta,r) fun(r.*cos(theta),r.*sin(theta)).*r;
Q = 4*quad2d(polarfun,0,pi/2,0,1,'AbsTol',1e-10);
```

It is best to put the singularity on the boundary by splitting the region of integration into two parts:

```
Q1 = 4*quad2d(polarfun,0,pi/2,0,0.5,'AbsTol',5e-11);
Q2 = 4*quad2d(polarfun,0,pi/2,0.5,1,'AbsTol',5e-11);
```

$Q = Q1 + Q2;$

## References

[1] L.F. Shampine, "Matlab Program for Quadrature in 2D." *Applied Mathematics and Computation*. Vol. 202, Issue 1, 2008, pp. 266–274.

## See Also

[dblquad](#) | [quad](#) | [quad1](#) | [quadv](#) | [quadgk](#) | [triplequad](#) | [function\\_handle](#) | [integral](#) | [integral2](#) | [integral3](#)

## How To

- “Anonymous Functions”

# quadgk

**Purpose** Numerically evaluate integral, adaptive Gauss-Kronrod quadrature

**Syntax**  
`q = quadgk(fun,a,b)`  
`[q,errbnd] = quadgk(fun,a,b)`  
`[q,errbnd] = quadgk(fun,a,b,param1,val1,param2,val2,...)`

**Description** `q = quadgk(fun,a,b)` attempts to approximate the integral of a scalar-valued function `fun` from `a` to `b` using high-order global adaptive quadrature and default error tolerances. The function `y = fun(x)` should accept a vector argument `x` and return a vector result `y`, where `y` is the integrand evaluated at each element of `x`. `fun` must be a function handle. Limits `a` and `b` can be `-Inf` or `Inf`. If both are finite, they can be complex. If at least one is complex, the integral is approximated over a straight line path from `a` to `b` in the complex plane.

“Parameterizing Functions” explains how to provide additional parameters to the function `fun`, if necessary.

`[q,errbnd] = quadgk(fun,a,b)` returns an approximate upper bound on the absolute error,  $|Q - I|$ , where `I` denotes the exact value of the integral.

`[q,errbnd] = quadgk(fun,a,b,param1,val1,param2,val2,...)` performs the integration with specified values of optional parameters. The available parameters are

Parameter	Description	
'AbsTol'	Absolute error tolerance.  The default value of 'AbsTol' is 1.e-10 (double), 1.e-5 (single).	quadgk attempts to satisfy $errbnd \leq \max(AbsTol, RelTol *  Q )$ . This is absolute error control when $ Q $ is sufficiently small and relative error control



Parameter	Description	
'RelTol'	<p>Relative error tolerance.</p> <p>The default value of 'RelTol' is 1.e-6 (double), 1.e-4 (single).</p>	<p>when <math> Q </math> is larger. For pure absolute error control use 'AbsTol' &gt; 0 and 'RelTol' = 0. For pure relative error control use 'AbsTol' = 0. Except when using pure absolute error control, the minimum relative tolerance is 'RelTol' <math>\geq 100 \cdot \text{eps}(\text{class}(Q))</math>.</p>
'Waypoints'	<p>Vector of integration waypoints.</p>	<p>If <math>\text{fun}(x)</math> has discontinuities in the interval of integration, the locations should be supplied as a Waypoints vector. When a, b, and the waypoints are all real, only the waypoints between a and b are used, and they are used in sorted order. Note that waypoints are not intended for singularities in <math>\text{fun}(x)</math>. Singular points should be handled by making them endpoints of separate integrations and adding the results.</p> <p>If a, b, or any entry of the waypoints vector is complex, the integration is performed over a</p>

# quadgk

Parameter	Description	
		sequence of straight line paths in the complex plane, from a to the first waypoint, from the first waypoint to the second, and so forth, and finally from the last waypoint to b.
'MaxIntervalCount'	Maximum number of intervals allowed. The default value is 650.	The 'MaxIntervalCount' parameter limits the number of intervals that quadgk uses at any one time after the first iteration. A warning is issued if quadgk returns early because of this limit. Routinely increasing this value is not recommended, but it may be appropriate when errbnd is small enough that the desired accuracy has nearly been achieved.

The list below contains information to help you determine which quadrature function in MATLAB to use:

- The quad function may be most efficient for low accuracies with nonsmooth integrands.
- The quadl function may be more efficient than quad at higher accuracies with smooth integrands.

- The `quadgk` function may be most efficient for high accuracies and oscillatory integrands. It supports infinite intervals and can handle moderate singularities at the endpoints. It also supports contour integration along piecewise linear paths.
- The `quadv` function vectorizes `quad` for an array-valued `fun`.
- If the interval is infinite,  $[a, \text{Inf})$ , then for the integral of `fun(x)` to exist, `fun(x)` must decay as `x` approaches infinity, and `quadgk` requires it to decay rapidly. Special methods should be used for oscillatory functions on infinite intervals, but `quadgk` can be used if `fun(x)` decays fast enough.
- The `quadgk` function will integrate functions that are singular at finite endpoints if the singularities are not too strong. For example, it will integrate functions that behave at an endpoint `c` like  $\log|x-c|$  or  $|x-c|^p$  for  $p \geq -1/2$ . If the function is singular at points inside  $(a,b)$ , write the integral as a sum of integrals over subintervals with the singular points as endpoints, compute them with `quadgk`, and add the results.

## Examples

### Integrand with a singularity at an integration end point

Write a function `myfun` that computes the integrand:

```
function y = myfun(x)
y = exp(x).*log(x);
```

Then pass `@myfun`, a function handle to `myfun`, to `quadgk`, along with the limits of integration, 0 to 1:

```
q = quadgk(@myfun,0,1)
```

```
q =
```

```
-1.3179
```

Alternatively, you can pass the integrand to `quadgk` as an anonymous function handle `F`:

# quadgk

---

```
f = @(x)exp(x).*log(x);
q = quadgk(f,0,1);
```

## Oscillatory integrand on a semi-infinite interval

Integrate over a semi-infinite interval with specified tolerances, and return the approximate error bound:

```
f = @(x)x.^5.*exp(-x).*sin(x);
[q,errbnd] = quadgk(f,0,inf,'RelTol',1e-8,'AbsTol',1e-12)
```

```
q =
```

```
-15.0000
```

```
errbnd =
```

```
9.4386e-009
```

## Contour integration around a pole

Use Waypoints to integrate around a pole using a piecewise linear contour:

```
f = @(z)1./(2*z - 1);
q = quadgk(f,-1-i,-1-i,'Waypoints',[1-i,1+i,-1+i])
```

```
q =
```

```
0.0000 + 3.1416i
```

## Algorithms

quadgk implements adaptive quadrature based on a Gauss-Kronrod pair (15<sup>th</sup> and 7<sup>th</sup> order formulas).

## Diagnostics

quadgk may issue one of the following warnings:

'Minimum step size reached' indicates that interval subdivision has produced a subinterval whose length is on the order of roundoff

error in the length of the original interval. A nonintegrable singularity is possible.

'Reached the limit on the maximum number of intervals in use' indicates that the integration was terminated before meeting the tolerance requirements and that continuing the integration would require more than `MaxIntervalCount` subintervals. The integral may not exist, or it may be difficult to approximate numerically. Increasing `MaxIntervalCount` usually does not help unless the tolerance requirements were nearly met when the integration was previously terminated.

'Infinite or Not-a-Number function value encountered' indicates a floating point overflow or division by zero during the evaluation of the integrand in the interior of the interval.

## References

[1] L.F. Shampine “Vectorized Adaptive Quadrature in MATLAB,” *Journal of Computational and Applied Mathematics*, 211, 2008, pp.131–140.

## See Also

`quad2d` | `dblquad` | `quad` | `quad1` | `quadv` | `triplequad` | `function_handle` | `integral` | `integral2` | `integral3`

## How To

- “Anonymous Functions”

# quadl

---

## Purpose

Numerically evaluate integral, adaptive Lobatto quadrature  
quadl will be removed in a future release. Use `integral` instead.

## Syntax

```
q = quadl(fun,a,b)
q = quadl(fun,a,b,tol)
quadl(fun,a,b,tol,trace)
[q,fcnt] = quadl(...)
```

## Description

`q = quadl(fun,a,b)` approximates the integral of function `fun` from `a` to `b`, to within an error of  $10^{-6}$  using recursive adaptive Lobatto quadrature. `fun` is a function handle. It accepts a vector `x` and returns a vector `y`, the function `fun` evaluated at each element of `x`. Limits `a` and `b` must be finite.

“Parameterizing Functions” explains how to provide additional parameters to the function `fun`, if necessary.

`q = quadl(fun,a,b,tol)` uses an absolute error tolerance of `tol` instead of the default, which is  $1.0e-6$ . Larger values of `tol` result in fewer function evaluations and faster computation, but less accurate results.

`quadl(fun,a,b,tol,trace)` with non-zero `trace` shows the values of `[fcnt a b-a q]` during the recursion.

`[q,fcnt] = quadl(...)` returns the number of function evaluations.

Use array operators `.*`, `./` and `.^` in the definition of `fun` so that it can be evaluated with a vector argument.

The function `quad` might be more efficient with low accuracies or nonsmooth integrands.

The list below contains information to help you determine which quadrature function in MATLAB to use:

- The `quad` function might be most efficient for low accuracies with nonsmooth integrands.
- The `quadl` function might be more efficient than `quad` at higher accuracies with smooth integrands.

- The `quadgk` function might be most efficient for high accuracies and oscillatory integrands. It supports infinite intervals and can handle moderate singularities at the endpoints. It also supports contour integration along piecewise linear paths.
- The `quadv` function vectorizes `quad` for an array-valued `fun`.
- If the interval is infinite,  $[a, \text{Inf})$ , then for the integral of `fun(x)` to exist, `fun(x)` must decay as `x` approaches infinity, and `quadgk` requires it to decay rapidly. Special methods should be used for oscillatory functions on infinite intervals, but `quadgk` can be used if `fun(x)` decays fast enough.
- The `quadgk` function will integrate functions that are singular at finite endpoints if the singularities are not too strong. For example, it will integrate functions that behave at an endpoint `c` like  $\log|x-c|$  or  $|x-c|^p$  for  $p \geq -1/2$ . If the function is singular at points inside  $(a,b)$ , write the integral as a sum of integrals over subintervals with the singular points as endpoints, compute them with `quadgk`, and add the results.

## Examples

Pass the function handle, `@myfun`, to `quadl`:

```
Q = quadl(@myfun,0,2);
```

where the function `myfun.m` is:

```
function y = myfun(x)
y = 1./(x.^3-2*x-5);
```

Pass anonymous function handle `F` to `quadl`:

```
F = @(x) 1./(x.^3-2*x-5);
Q = quadl(F,0,2);
```

## Algorithms

`quadl` implements a high order method using an adaptive Gauss/Lobatto quadrature rule.

# quadl

---

## Diagnostics

quadl might issue one of the following warnings:

'Minimum step size reached' indicates that the recursive interval subdivision has produced a subinterval whose length is on the order of roundoff error in the length of the original interval. A nonintegrable singularity is possible.

'Maximum function count exceeded' indicates that the integrand has been evaluated more than 10,000 times. A nonintegrable singularity is likely.

'Infinite or Not-a-Number function value encountered' indicates a floating point overflow or division by zero during the evaluation of the integrand in the interior of the interval.

## References

[1] Gander, W. and W. Gautschi, "Adaptive Quadrature – Revisited," BIT, Vol. 40, 2000, pp. 84-101. This document is also available at <http://www.inf.ethz.ch/personal/gander>.

## See Also

quad2d | dblquad | quad | quadgk | triplequad | function\_handle | integral | integral2 | integral3

## How To

- "Anonymous Functions"



**Purpose**

Vectorized quadrature

quadv will be removed in a future release. Use `integral` with the 'ArrayValued' option instead.

**Syntax**

```
Q = quadv(fun,a,b)
Q = quadv(fun,a,b,tol)
Q = quadv(fun,a,b,tol,trace)
[Q,fcnt] = quadv(...)
```

**Description**

`Q = quadv(fun,a,b)` approximates the integral of the complex array-valued function `fun` from `a` to `b` to within an error of  $1.e-6$  using recursive adaptive Simpson quadrature. `fun` is a function handle. The function `Y = fun(x)` should accept a scalar argument `x` and return an array result `Y`, whose components are the integrands evaluated at `x`. Limits `a` and `b` must be finite.

“Parameterizing Functions” explains how to provide addition parameters to the function `fun`, if necessary.

`Q = quadv(fun,a,b,tol)` uses the absolute error tolerance `tol` for all the integrals instead of the default, which is  $1.e-6$ .

---

**Note** The same tolerance is used for all components, so the results obtained with `quadv` are usually not the same as those obtained with `quad` on the individual components.

---

`Q = quadv(fun,a,b,tol,trace)` with non-zero `trace` shows the values of `[fcnt a b-a Q(1)]` during the recursion.

`[Q,fcnt] = quadv(...)` returns the number of function evaluations.

The list below contains information to help you determine which quadrature function in MATLAB to use:

- The `quad` function might be most efficient for low accuracies with nonsmooth integrands.

- The `quadl` function might be more efficient than `quad` at higher accuracies with smooth integrands.
- The `quadgk` function might be most efficient for high accuracies and oscillatory integrands. It supports infinite intervals and can handle moderate singularities at the endpoints. It also supports contour integration along piecewise linear paths.
- The `quadv` function vectorizes `quad` for an array-valued fun.
- If the interval is infinite,  $[a, \text{Inf})$ , then for the integral of  $\text{fun}(x)$  to exist,  $\text{fun}(x)$  must decay as  $x$  approaches infinity, and `quadgk` requires it to decay rapidly. Special methods should be used for oscillatory functions on infinite intervals, but `quadgk` can be used if  $\text{fun}(x)$  decays fast enough.
- The `quadgk` function will integrate functions that are singular at finite endpoints if the singularities are not too strong. For example, it will integrate functions that behave at an endpoint  $c$  like  $\log|x-c|$  or  $|x-c|^p$  for  $p \geq -1/2$ . If the function is singular at points inside  $(a,b)$ , write the integral as a sum of integrals over subintervals with the singular points as endpoints, compute them with `quadgk`, and add the results.

## Examples

For the parameterized array-valued function `myarrayfun`, defined by

```
function Y = myarrayfun(x,n)
Y = 1./((1:n)+x);
```

the following command integrates `myarrayfun`, for the parameter value  $n = 10$  between  $a = 0$  and  $b = 1$ :

```
Qv = quadv(@(x)myarrayfun(x,10),0,1);
```

The resulting array `Qv` has 10 elements estimating  $Q(k) = \log((k+1)/(k))$ , for  $k = 1:10$ .

The entries in `Qv` are slightly different than if you compute the integrals using `quad` in a loop:

```
for k = 1:10
 Qs(k) = quadv(@(x)myscalarfun(x,k),0,1);
end
```

where `myscalarfun` is:

```
function y = myscalarfun(x,k)
y = 1./(k+x);
```

**See Also**

[quad](#) | [quad2d](#) | [quadgk](#) | [quadl](#) | [dblquad](#) | [triplequad](#) |  
[function\\_handle](#) | [integral](#) | [integral2](#) | [integral3](#)

# matlab.unittest.qualifications

---

## Purpose

Summary of classes in MATLAB Qualifications Interface

## Description

Qualifications are methods for testing values and responding to failures. Qualification failures might or might not correspond to a test failure, and they might or might not continue execution in the test when one is encountered. To determine which qualification to use, see “Types of Qualifications”.

matlab.unittest.qualifications.AssertionQualification  
Qualification to validate preconditions of a test

matlab.unittest.qualifications.AssumptionQualification  
Qualification to filter test content

matlab.unittest.qualifications.FatalAssertionQualification  
Qualification to abort test execution

matlab.unittest.qualifications.VerificationQualification  
Qualification to produce soft-failure conditions

The package contains the following event data classes:

matlab.unittest.qualifications.ExceptionEventData  
ExceptionThrown event listeners

matlab.unittest.qualifications.QualificationEventData  
Qualification event listeners

The package contains the following exception handling classes:

matlab.unittest.qualifications.AssertionFailedException  
Exception for assertion failures

matlab.unittest.qualifications.AssumptionFailedException  
Exception for assumption failures

matlab.unittest.qualifications.FatalAssertionFailedException  
Exception for fatal assertion failures

## Purpose

Qualification to validate preconditions of a test

## Description

The `Assertable` class provides a qualification to validate preconditions of a test. Apart from actions performed for failures, the `Assertable` class works the same as other `matlab.unittest` qualifications.

Upon an assertion failure, the `Assertable` class throws an `AssertionFailedException` to inform the testing framework of the failure. This is most useful when a failure at the assertion point renders the rest of the current test method invalid, yet does not prevent proper execution of other test methods. Often, you use assertions to ensure that preconditions of the current test are not violated or that fixtures are set up correctly. Make sure the test content is “Exception Safe” on page 1-5301. If you cannot make the fixture teardown exception safe or if you cannot recover it after failure, use fatal assertions instead.

Use assertions to allow remaining test methods to receive coverage when preconditions are violated in a test and all fixture states are restorable. Assertions also reduce the noise level of failures by not performing later verifications that fail due the precondition failures. In the event of a failure, however, the test framework marks the full content of the test method that failed as incomplete. Therefore, if the failure does not affect the preconditions of the test or cause problems with fixture setup or teardown, use verifications, which give the added information for added information that the full test content was run.

## Methods

<code>assertClass</code>	Assert exact class of specified value
<code>assertEmpty</code>	Assert value is empty
<code>assertEqual</code>	Assert value is equal to specified value
<code>assertError</code>	Assert function throws specified exception

# matlab.unittest.qualifications.Assertable

---

<code>assertFail</code>	Produce unconditional assertion failure
<code>assertFalse</code>	Assert value is false
<code>assertGreaterThan</code>	Assert value is greater than specified value
<code>assertGreaterThanOrEqual</code>	Assert value is greater than or equal to specified value
<code>assertInstanceOf</code>	Assert value is object of specified type
<code>assertLength</code>	Assert value has specified length
<code>assertLessThan</code>	Assert value is less than specified value
<code>assertLessThanOrEqual</code>	Assert value is less than or equal to specified value
<code>assertMatches</code>	Assert string matches specified regular expression
<code>assertNotEmpty</code>	Assert value is not empty
<code>assertNotEqual</code>	Assert value is not equal to specified value
<code>assertNotSameHandle</code>	Assert value is not handle to specified instance
<code>assertNumElements</code>	Assert value has specified element count
<code>assertReturnsTrue</code>	Assert function returns true when evaluated
<code>assertSameHandle</code>	Assert two values are handles to same instance
<code>assertSize</code>	Assert value has specified size

<code>assertSubstring</code>	Assert string contains specified string
<code>assertThat</code>	Assert that value meets specified constraint
<code>assertTrue</code>	Assert value is true
<code>assertWarning</code>	Assert function issues specified warning
<code>assertWarningFree</code>	Assert function issues no warnings

## Events

<code>AssertionFailed</code>	Triggered upon failing assertion. A <code>QualificationEventData</code> object is passed to listener callback functions.
<code>AssertionPassed</code>	Triggered upon passing assertion. A <code>QualificationEventData</code> object is passed to listener callback functions.

## Definitions

### Exception Safe

Test content is *exception safe* when all fixture teardown is performed with `addTeardown` or through the appropriate object destructors when a failure occurs. This ensures that the failure does not affect later testing due to stale fixtures.

This code is not exception safe. After an assertion failure, the test framework does not close the figure.

```
% Not exception safe
f = figure;
testCase.assertEqual(actual, expected);
close(f);
```

# matlab.unittest.qualifications.Assertable

---

This code is exception safe because the test framework closes the figure in all cases.

```
% Exception safe
f = figure;
testCase.addTeardown(@close, f);
testCase.assertEqual(actual, expected);
```

However, tearing down a fixture using `addTeardown` does not guarantee code is exception safe. This code shows a failure in `assertEqual`.

```
% Not exception safe
f = figure;
testCase.assertEqual(actual, expected);
testCase.addTeardown(@close, f);
```

## Copy Semantics

Handle. To learn how handle classes affect copy operations, see Copying Objects in the MATLAB documentation.

## Examples

### Test for Preconditions Using Assertions

Use assertable qualifications to test for preconditions. This example will create a test case to write a polynomial to a MAT-file.

Create `DocPolynomSaveLoadTest` Test Case. Refer to the following `DocPolynomSaveLoadTest` test case in the subsequent steps in this example. The steps highlight specific code in the `testSaveLoad` function; the code statements are not intended to be executed outside the context of the class definition file.

### DocPolynomSaveLoadTest Class Definition File

```
classdef DocPolynomSaveLoadTest < matlab.unittest.TestCase

 methods (TestClassSetup)
 function addDocPolynomClassToPath(testCase)
 origPath = path;
 testCase.addTeardown(@path, origPath);
 end
 end
end
```



# matlab.unittest.qualifications.Assertable

---

```
 addpath(fullfile(matlabroot, ...
 'help', 'techdoc', 'matlab_oop', 'examples'));
 end
end

methods (Test)
 function testSaveLoad(testCase)

 import matlab.unittest.diagnostics.Diagnostic;

 %% Phase 1: Setup
 % Create a temporary working folder
 tempFolder = tempname;
 [success, message] = mkdir(tempFolder);
 testCase.assertTrue(success, ...
 Diagnostic.join('Could not create temporary folder.',
 message));
 testCase.addTeardown(@() testCase.cleanUpTemporaryFolder(
 tempFolder));

 % Change to the temporay folder and register the
 % teardown, which restores the original folder
 origFolder = pwd;
 testCase.addTeardown(@cd, origFolder);
 cd(tempFolder);

 %% Phase 2: Exercise
 % Save the instance to a mat file.
 p = DocPolynom([1, 0, 1]);
 save('DocPolynomFile', 'p');

 % Validate Precondition. Save resulted in valid .mat file
 testCase.assertEqual(exist('DocPolynomFile.mat', 'file'),
 2, Diagnostic.join(...
 'mat file was not saved correctly.', @() dir(pwd)));

 loaded = load('DocPolynomFile');
```

# matlab.unittest.qualifications.Assertable

---

```
%% Phase 3: Verify
testCase.verifyEqual(loaded.p, p,...
 'Loaded polynomial did not equal original polynomial.');
```

```
%% Phase 4: Teardown
% Done inline via calls to addTeardown at the points
% at which the state was changed.
```

```
end
end

methods(Access=private)
function cleanUpTemporaryFolder(testCase,tempFolder)
 % Clean up the temporary folder and fatally assert
 % that it was correctly cleaned up.

 import matlab.unittest.diagnostics.Diagnostic;

 [success, message] = rmdir(tempFolder, 's');
 testCase.fatalAssertTrue(success, ...
 Diagnostic.join('Could not remove temporary folder.',...
 message));
end
end

end
```

To execute the MATLAB commands in “Run DocPolynomSaveLoadTest Test Case”, add the DocPolynomSaveLoadTest.m file to a folder on your MATLAB path.

The testSaveLoad function consists of the following phases:

- Phase 1: Setup — Create and verify precondition code.
- Phase 2: Exercise — Create a DocPolynom object and save it to a MAT-file.
- Phase 3: Verify — Test that object was successfully saved.
- Phase 4: Teardown — Execute teardown code.

Define phase 1 precondition. For this test, use a temporary folder for creating a DocPolynom object. The precondition for continuing with this test is that the following commands execute successfully.

```
tempFolder = tempname;
[success, message] = mkdir(tempFolder);
```

Test the results of the `mkdir` function. Use the `assertTrue` method to test the `mkdir` `success` argument for errors. If an assertion occurs, the remainder of the `testSaveLoad` test method is invalid, and the test is marked Incomplete.

```
testCase.assertTrue(success, ...
 Diagnostic.join('Could not create the temporary folder.', ...
 message));
```

If the `mkdir` function fails, MATLAB displays the diagnostic message, `Could not create the temporary folder`, as well as the contents of the `mkdir` `message` argument.

Add teardown fixture code. Creating a temporary folder is setup code, which requires a corresponding call to the `rmdir` function to restore MATLAB to the original state. Use the `addTeardown` method to ensure the teardown code executes even when an exception is thrown in the middle of the test method. This makes the test Exception Safe.

```
testCase.addTeardown(@() testCase.cleanupTemporaryFolder(tempFolder));
```

Place teardown code in the helper function. Although the `addTeardown` statement occurs in the same code block as the `mkdir` setup statement,

# matlab.unittest.qualifications.Assertable

---

the `cleanUpTemporaryFolder` code is executed in phase 4 of the test method.

In the `DocPolynomSaveLoadTest` test case, the helper function, `cleanUpTemporaryFolder`, executes the `rmdir` function.

Define the precondition for creating valid MAT-File. A precondition for verifying that the `DocPolynom` object was correctly saved and loaded is that the MAT-file, `DocPolynomFile.mat`, was successfully created. The following code in the `Phase 2: Exercise` block tests this condition. If an assertion occurs, the remainder of the `testSaveLoad` test method is invalid, and the test is marked `Failed` and `Incomplete`.

```
testCase.assertEqual(exist('DocPolynomFile.mat','file'), 2, ...
 Diagnostic.join('The mat file was not saved correctly.', ...
 @() dir(pwd)));
```

If the file was not created, MATLAB displays the diagnostic message, `The mat file was not saved correctly`, as well as the contents of the temporary folder.

Run `DocPolynomSaveLoadTest` Test Case.

```
tc = DocPolynomSaveLoadTest;
run(tc);
```

```
Running DocPolynomSaveLoadTest
.
Done DocPolynomSaveLoadTest
```

---

## See Also

[TestCase](#) | [Assumable](#) | [FatalAssertable](#) | [Verifiable](#) | [matlab.unittest.qualifications](#) | [QualificationEventData](#)

## Concepts

# matlab.unittest.qualifications.Assertable.assertClass

## Purpose

Assert exact class of specified value

## Syntax

```
assertClass(assertable,actual,className)
assertClass(assertable,actual,metaClass)
assertClass(___,diagnostic)
```

## Description

`assertClass(assertable,actual,className)` asserts that `actual` is a MATLAB value whose class is the class specified by `className`.

`assertClass(assertable,actual,metaClass)` asserts that `actual` is a MATLAB value whose class is the class specified by the `meta.class` instance `metaClass`. The instance must be an exact class match. See `assertInstanceOf` to assert inclusion in a class hierarchy.

`assertClass( ___,diagnostic)` also displays the diagnostic information in `diagnostic` upon a failure.

## Tips

- The method is functionally equivalent to:

```
import matlab.unittest.constraints.IsOfClass;
assertable.assertThat(actual, IsOfClass(className));
assertable.assertThat(actual, IsOfClass(metaClass));
```

There exists more functionality when using the `IsOfClass` constraint directly via `assertThat`.

## Input Arguments

### **assertable**

The `matlab.unittest.TestCase` instance which is used to pass or fail the assertion in conjunction with the test running framework.

### **actual**

The value to test.

### **className**

Name of class, specified as a string.

### **metaClass**

# matlab.unittest.qualifications.Assertable.assertClass

---

An instance of `meta.class`.

## **diagnostic**

Diagnostic information to display upon a failure, specified as one of the following:

- string
- function handle
- `matlab.unittest.diagnostics.Diagnostic` object

Diagnostic values can be nonscalar. For more information, see `matlab.unittest.diagnostics.Diagnostic`.

## **Examples**

See examples for `verifyClass`.

## **See Also**

`assertThat` | `assertInstanceOf`

# matlab.unittest.qualifications.Assertable.assertEmpty

<b>Purpose</b>	Assert value is empty
<b>Syntax</b>	<pre>assertEmpty(assertable,actual) assertEmpty(assertable,actual,diagnostic)</pre>
<b>Description</b>	<p><code>assertEmpty(assertable,actual)</code> asserts that <code>actual</code> is an empty MATLAB value.</p> <p><code>assertEmpty(assertable,actual,diagnostic)</code> also displays the diagnostic information in <code>diagnostic</code> upon a failure.</p>
<b>Tips</b>	<ul style="list-style-type: none"><li>This method is functionally equivalent to: <pre>import matlab.unittest.constraints.IsEmpty; assertable.assertThat(actual, IsEmpty());</pre><p>This method is a convenience method. There exists more functionality when using the <code>IsEmpty</code> constraint directly via <code>assertThat</code>.</p></li></ul>
<b>Input Arguments</b>	<p><b>assertable</b></p> <p>The <code>matlab.unittest.TestCase</code> instance which is used to pass or fail the assertion in conjunction with the test running framework.</p> <p><b>actual</b></p> <p>The value to test.</p> <p><b>diagnostic</b></p> <p>Diagnostic information to display upon a failure, specified as one of the following:</p> <ul style="list-style-type: none"><li>string</li><li>function handle</li><li><code>matlab.unittest.diagnostics.Diagnostic</code> object</li></ul> <p>Diagnostic values can be nonscalar. For more information, see <code>matlab.unittest.diagnostics.Diagnostic</code>.</p>

# matlab.unittest.qualifications.Assertable.assertEmpty

---

**Examples**      See examples for `verifyEmpty`.

**See Also**      `assertThat` | `assertNotEmpty` | `isempty`



# matlab.unittest.qualifications.Assertable.assertEqual

## Purpose

Assert value is equal to specified value

## Syntax

```
assertEqual(assertable,actual,expected)
assertEqual(____,Name,Value)
assertEqual(____,diagnostic)
```

## Description

`assertEqual(assertable,actual,expected)` asserts that `actual` is strictly equal to `expected`.

`assertEqual( ____,Name,Value)` asserts equality with additional options specified by one or more `Name,Value` pair arguments.

`assertEqual( ____,diagnostic)` also displays the diagnostic information in `diagnostic` upon a failure.

## Tips

- This method is functionally equivalent to any of the following:

```
import matlab.unittest.constraints.IsEqualTo;
assertable.assertThat(actual, IsEqualTo(expected));
```

```
import matlab.unittest.constraints.IsEqualTo;
import matlab.unittest.constraints.AbsoluteTolerance;
assertable.assertThat(actual, IsEqualTo(expected, ...
 'Within', AbsoluteTolerance(abstol)));
```

```
import matlab.unittest.constraints.IsEqualTo;
import matlab.unittest.constraints.RelativeTolerance;
assertable.assertThat(actual, IsEqualTo(expected, ...
 'Within', RelativeTolerance(reltol)));
```

```
import matlab.unittest.constraints.IsEqualTo;
import matlab.unittest.constraints.AbsoluteTolerance;
import matlab.unittest.constraints.RelativeTolerance;
assertable.assertThat(actual, IsEqualTo(expected, ...
 'Within', AbsoluteTolerance(abstol) | RelativeTolerance(reltol))
```

# matlab.unittest.qualifications.Assertable.assertEqual

---

There exists more functionality when using the `IsEqualTo`, `RelativeTolerance`, and `IsEqualTo` constraints directly via `assertThat`.

## Input Arguments

### **assertable**

The `matlab.unittest.TestCase` instance which is used to pass or fail the assertion in conjunction with the test running framework.

### **actual**

The value to test.

### **expected**

Expected value.

### **diagnostic**

Diagnostic information to display upon a failure, specified as one of the following:

- string
- function handle
- `matlab.unittest.diagnostics.Diagnostic` object

Diagnostic values can be nonscalar. For more information, see `matlab.unittest.diagnostics.Diagnostic`.

## **Name-Value Pair Arguments**

Specify optional comma-separated pairs of `Name`, `Value` arguments. `Name` is the argument name and `Value` is the corresponding value. `Name` must appear inside single quotes ( `' '` ). You can specify several name and value pair arguments in any order as `Name1, Value1, ..., NameN, ValueN`.

**'AbsTol'**

**'RelTol'**

# matlab.unittest.qualifications.Assertable.assertEqual

---

**Examples**      See examples for `verifyEqual`.

**See Also**      `assertThat` | `assertNotEqual`

# matlab.unittest.qualifications.Assertable.assertError

---

**Purpose** Assert function throws specified exception

**Syntax** `assertError(assertable,actual,identifier)`  
`assertError(assertable,actual,metaClass)`  
`assertError(___,diagnostic)`

**Description** `assertError(assertable,actual,identifier)` asserts that `actual` is a function handle that throws an exception with an error identifier that is equal to `identifier`.

`assertError(assertable,actual,metaClass)` asserts that `actual` is a function handle that throws an exception whose type is defined by the `meta.class` instance specified in `metaClass`. This method does not require the instance to be an exact class match, but rather it must be in the specified class hierarchy, and that hierarchy must include the `MException` class.

`assertError(___,diagnostic)` also displays the diagnostic information in `diagnostic` upon a failure.

**Tips** • This method is functionally equivalent to:

```
import matlab.unittest.constraints.Throws;
assertable.assertThat(actual, Throws(identifier));
assertable.assertThat(actual, Throws(metaClass));
```

There exists more functionality when using the `Throws` constraint directly via `assertThat`.

## Input Arguments

### **assertable**

The `matlab.unittest.TestCase` instance which is used to pass or fail the assertion in conjunction with the test running framework.

### **actual**

The value to test.

### **identifier**

# matlab.unittest.qualifications.Assertable.assertError

---

Error identifier, specified as a string.

## **metaClass**

An instance of meta.class.

## **diagnostic**

Diagnostic information to display upon a failure, specified as one of the following:

- string
- function handle
- matlab.unittest.diagnostics.Diagnostic object

Diagnostic values can be nonscalar. For more information, see `matlab.unittest.diagnostics.Diagnostic`.

## **Examples**

See examples for `verifyError`.

## **See Also**

`assertThat` | `assertWarning` | `MException` | `error`

# matlab.unittest.qualifications.Assertable.assertFail

---

**Purpose** Produce unconditional assertion failure

**Syntax** `assertFail(assertable)`  
`assertFail(assertable,diagnostic)`

**Description** `assertFail(assertable)` produces an unconditional assertion failure when encountered.

`assertFail(assertable,diagnostic)` also displays the diagnostic information in `diagnostic` upon a failure.

## Input Arguments

### **assertable**

The `matlab.unittest.TestCase` instance which is used to pass or fail the assertion in conjunction with the test running framework.

### **diagnostic**

Diagnostic information to display upon a failure, specified as one of the following:

- string
- function handle
- `matlab.unittest.diagnostics.Diagnostic` object

Diagnostic values can be nonscalar. For more information, see `matlab.unittest.diagnostics.Diagnostic`.

**Examples** See examples for `verifyFail`.

# matlab.unittest.qualifications.Assertable.assertFalse

## Purpose

Assert value is false

## Syntax

```
assertFalse(assertable,actual)
assertFalse(assertable,actual,diagnostic)
```

## Description

`assertFalse(assertable,actual)` asserts that `actual` is a scalar logical with the value of false.

`assertFalse(assertable,actual,diagnostic)` also displays the diagnostic information in `diagnostic` upon a failure.

## Tips

- This method passes if and only if the actual value is a scalar logical with a value of false. Therefore, entities such as empty arrays, false valued arrays, and zero doubles produce failures when used in this method, despite these entities exhibiting "false-like" behavior such as bypassing the execution of code inside of "if" statements.
- This method is functionally equivalent to:

```
import matlab.unittest.constraints.IsFalse;
assertable.assertThat(actual,.IsFalse());
```

There exists more functionality when using the `IsFalse` constraint directly via `assertThat`.

- Unlike `assertTrue`, this method may create a new constraint for each call. For performance critical uses, consider using `assertTrue`.

## Input Arguments

### **assertable**

The `matlab.unittest.TestCase` instance which is used to pass or fail the assertion in conjunction with the test running framework.

### **actual**

The value to test.

### **diagnostic**

Diagnostic information to display upon a failure, specified as one of the following:

# matlab.unittest.qualifications.Assertable.assertFalse

---

- string
- function handle
- matlab.unittest.diagnostics.Diagnostic object

Diagnostic values can be nonscalar. For more information, see `matlab.unittest.diagnostics.Diagnostic`.

**Examples** For examples, see `verifyFalse`.

**See Also** `assertThat` | `assertTrue`



# matlab.unittest.qualifications.Assertable.assertGreaterThan

## Purpose

Assert value is greater than specified value

## Syntax

```
assertGreaterThan(assertable,actual,floor)
assertGreaterThan(assertable,actual,floor,diagnostic)
```

## Description

`assertGreaterThan(assertable,actual,floor)` asserts that all elements of `actual` are greater than all the elements of `floor`.

`assertGreaterThan(assertable,actual,floor,diagnostic)` also displays the diagnostic information in `diagnostic` upon a failure.

## Tips

- This method is functionally equivalent to:

```
import matlab.unittest.constraints.IsGreaterThan;
assertable.assertThat(actual, IsGreaterThan(floor));
```

There exists more functionality when using the `IsGreaterThan` constraint directly via `assertThat`.

## Input Arguments

### **assertable**

The `matlab.unittest.TestCase` instance which is used to pass or fail the assertion in conjunction with the test running framework.

### **actual**

The value to test. `actual` must be the same size as `floor` unless either one is scalar, at which point scalar expansion occurs.

### **floor**

Minimum value, exclusive.

### **diagnostic**

Diagnostic information to display upon a failure, specified as one of the following:

- string
- function handle

# matlab.unittest.qualifications.Assertable.assertGreaterThan

---

- `matlab.unittest.diagnostics.Diagnostic` object

Diagnostic values can be nonscalar. For more information, see `matlab.unittest.diagnostics.Diagnostic`.

## Examples

See examples for `verifyGreaterThan`.

## See Also

`assertThat` | `assertGreaterThanOrEqual` |  
`assertLessThan` | `assertLessThanOrEqual` | `gt` |  
`matlab.unittest.constraints.IsGreaterThan` |  
`matlab.unittest.diagnostics.Diagnostic`

# matlab.unittest.qualifications.Assertable.assertGreaterThanOrEqualTo

## Purpose

Assert value is greater than or equal to specified value

## Syntax

```
assertGreaterThanOrEqualTo(assertable,actual,floor)
assertGreaterThanOrEqualTo(assertable,actual,floor,diagnostic)
```

## Description

`assertGreaterThanOrEqualTo(assertable,actual,floor)` asserts that all elements of `actual` are greater than or equal to all the elements of `floor`.

`assertGreaterThanOrEqualTo(assertable,actual,floor,diagnostic)` also displays the diagnostic information in `diagnostic` upon a failure.

## Tips

- This method is functionally equivalent to:

```
import matlab.unittest.constraints.IsGreaterThanOrEqualTo;
assertable.assertThat(actual, IsGreaterThanOrEqualTo(floor));
```

There exists more functionality when using the `IsGreaterThanOrEqualTo` constraint directly via `assertThat`.

## Input Arguments

### **assertable**

The `matlab.unittest.TestCase` instance which is used to pass or fail the assertion in conjunction with the test running framework.

### **actual**

The value to test. `actual` must be the same size as `floor` unless either one is scalar, at which point scalar expansion occurs.

### **floor**

Minimum value.

### **diagnostic**

Diagnostic information to display upon a failure, specified as one of the following:

- string

# matlab.unittest.qualifications.Assertable.assertGreaterThanOrEqualTo

---

- function handle
- matlab.unittest.diagnostics.Diagnostic object

Diagnostic values can be nonscalar. For more information, see `matlab.unittest.diagnostics.Diagnostic`.

## Examples

See examples for `verifyGreaterThanOrEqualTo`.

## See Also

`assertThat` | `assertGreaterThan` |  
`assertLessThanOrEqualTo` | `assertLessThan` | `ge` |  
`matlab.unittest.constraints.IsGreaterThanOrEqualTo` |  
`matlab.unittest.diagnostics.Diagnostic`

# matlab.unittest.qualifications.Assertable.assertInstanceOf

## Purpose

Assert value is object of specified type

## Syntax

```
assertInstanceOf(assertable,actual,className)
assertInstanceOf(assertable,actual,metaClass)
assertInstanceOf(___,diagnostic)
```

## Description

`assertInstanceOf(assertable,actual,className)` asserts that `actual` is a MATLAB value whose class is the class specified by `className`.

`assertInstanceOf(assertable,actual,metaClass)` `actual` is a MATLAB value whose class is the class specified by the `meta.class` instance `metaClass`.

`assertInstanceOf(___,diagnostic)` also displays the diagnostic information in `diagnostic` upon a failure.

## Tips

- This method is functionally equivalent to:

```
assertable.assertThat(actual, IsInstanceOf(className));
assertable.assertThat(actual, IsInstanceOf(metaClass));
```

There exists more functionality when using the `IsInstanceOf` constraint directly via `assertThat`.

## Input Arguments

### **assertable**

The `matlab.unittest.TestCase` instance which is used to pass or fail the assertion in conjunction with the test running framework.

### **actual**

The value to test.

### **className**

Name of class, specified as a string.

### **metaClass**

An instance of `meta.class`.

# matlab.unittest.qualifications.Assertable.assertInstanceOf

---

## **diagnostic**

Diagnostic information to display upon a failure, specified as one of the following:

- string
- function handle
- matlab.unittest.diagnostics.Diagnostic object

Diagnostic values can be nonscalar. For more information, see `matlab.unittest.diagnostics.Diagnostic`.

## **Examples**

See examples for `verifyInstanceOf`.

## **See Also**

`assertThat` | `assertClass` | `isa`

# matlab.unittest.qualifications.Assertable.assertLength

---

## Purpose

Assert value has specified length

## Syntax

```
assertLength(assertable,actual,expectedLength)
assertLength(assertable,actual,expectedLength,diagnostic)
```

## Description

`assertLength(assertable,actual,expectedLength)` that `actual` is a MATLAB array whose length is `expectedLength`.

`assertLength(assertable,actual,expectedLength,diagnostic)` also displays the diagnostic information in `diagnostic` upon a failure.

## Tips

- This method is functionally equivalent to:

```
import matlab.unittest.constraints.HasLength;
assertable.assertThat(actual, HasLength(expectedLength));
```

There exists more functionality when using the `HasLength` constraint directly via `assertThat`.

## Input Arguments

### **assertable**

The `matlab.unittest.TestCase` instance which is used to pass or fail the assertion in conjunction with the test running framework.

### **actual**

The value to test.

### **expectedLength**

The length of an array is defined as the largest dimension of that array.

### **diagnostic**

Diagnostic information to display upon a failure, specified as one of the following:

- string
- function handle

# matlab.unittest.qualifications.Assertable.assertLength

---

- `matlab.unittest.diagnostics.Diagnostic` object

Diagnostic values can be nonscalar. For more information, see `matlab.unittest.diagnostics.Diagnostic`.

## Examples

See examples for `verifyLength`.

## See Also

`assertThat` | `assertSize` | `assertNumElements` | `length`



# matlab.unittest.qualifications.Assertable.assertLessThan

---

## Purpose

Assert value is less than specified value

## Syntax

```
assertLessThan(assertable,actual,ceiling)
assertLessThan(assertable,actual,ceiling,diagnostic)
```

## Description

`assertLessThan(assertable,actual,ceiling)` asserts that all elements of `actual` are less than all the elements of `ceiling`.

`assertLessThan(assertable,actual,ceiling,diagnostic)` also displays the diagnostic information in `diagnostic` upon a failure.

## Tips

- This method is functionally equivalent to:

```
import matlab.unittest.constraints.IsLessThan;
assertable.assertThat(actual, IsLessThan(ceiling));
```

There exists more functionality when using the `IsLessThan` constraint directly via `assertThat`.

## Input Arguments

### **assertable**

The `matlab.unittest.TestCase` instance which is used to pass or fail the assertion in conjunction with the test running framework.

### **actual**

The value to test. `actual` must be the same size as `ceiling` unless either one is scalar, at which point scalar expansion occurs.

### **ceiling**

Maximum value, exclusive.

### **diagnostic**

Diagnostic information to display upon a failure, specified as one of the following:

- string
- function handle

# matlab.unittest.qualifications.Assertable.assertLessThan

---

- `matlab.unittest.diagnostics.Diagnostic` object

Diagnostic values can be nonscalar. For more information, see `matlab.unittest.diagnostics.Diagnostic`.

## Examples

See examples for `verifyLessThan`.

## See Also

`assertThat` | `assertLessThanOrEqual` |  
`assertGreaterThan` | `assertGreaterThanOrEqual` |  
`lt` | `matlab.unittest.constraints.IsLessThan` |  
`matlab.unittest.diagnostics.Diagnostic`

# matlab.unittest.qualifications.Assertable.assertLessThanOrEqual

## Purpose

Assert value is less than or equal to specified value

## Syntax

```
assertLessThanOrEqual(assertable,actual,ceiling)
assertLessThanOrEqual(assertable,actual,ceiling,diagnostic)
```

## Description

`assertLessThanOrEqual(assertable,actual,ceiling)` asserts that all elements of `actual` are less than or equal to all the elements of `ceiling`.

`assertLessThanOrEqual(assertable,actual,ceiling,diagnostic)` also displays the diagnostic information in `diagnostic` upon a failure.

## Tips

- This method is functionally equivalent to:

```
import matlab.unittest.constraints.IsLessThanOrEqualTo;
assertable.assertThat(actual, IsLessThanOrEqualTo(ceiling));
```

There exists more functionality when using the `IsLessThanOrEqualTo` constraint directly via `assertThat`.

## Input Arguments

### **assertable**

The `matlab.unittest.TestCase` instance which is used to pass or fail the assertion in conjunction with the test running framework.

### **actual**

The value to test. `actual` must be the same size as `ceiling` unless either one is scalar, at which point scalar expansion occurs.

### **ceiling**

Maximum value.

### **diagnostic**

Diagnostic information to display upon a failure, specified as one of the following:

- string

- function handle
- matlab.unittest.diagnostics.Diagnostic object

Diagnostic values can be nonscalar. For more information, see `matlab.unittest.diagnostics.Diagnostic`.

## Examples

See examples for `verifyLessThanOrEqualTo`.

## See Also

`assertThat` | `assertLessThan` | `assertGreaterThan`  
| `assertGreaterThanOrEqualTo` | `le` |  
`matlab.unittest.constraints.IsLessThanOrEqualTo` |  
`matlab.unittest.diagnostics.Diagnostic`

# matlab.unittest.qualifications.Assertable.assertMatches

## Purpose

Assert string matches specified regular expression

## Syntax

```
assertMatches(assertable,actual,expression)
assertMatches(assertable,actual,expression,diagnostic)
```

## Description

`assertMatches(assertable,actual,expression)` asserts that `actual` is a string that matches the regular expression defined by `expression`.

`assertMatches(assertable,actual,expression,diagnostic)` also displays the diagnostic information in `diagnostic` upon a failure.

## Tips

- This method is functionally equivalent to:

```
import matlab.unittest.constraints.Matches;
assertable.assertThat(actual, Matches(expression));
```

There exists more functionality when using the `Matches` constraint directly via `assertThat`.

## Input Arguments

### **assertable**

The `matlab.unittest.TestCase` instance which is used to pass or fail the assertion in conjunction with the test running framework.

### **actual**

The value to test.

### **expression**

The value to match, specified as a regular expression.

### **diagnostic**

Diagnostic information to display upon a failure, specified as one of the following:

- string
- function handle

# matlab.unittest.qualifications.Assertable.assertMatches

---

- `matlab.unittest.diagnostics.Diagnostic` object

Diagnostic values can be nonscalar. For more information, see `matlab.unittest.diagnostics.Diagnostic`.

**Examples** See examples for `verifyMatches`.

**See Also** `assertThat` | `assertSubstring` | `regexp`

# matlab.unittest.qualifications.Assertable.assertNotEmpty

---

## Purpose

Assert value is not empty

## Syntax

```
assertNotEmpty(assertable,actual)
assertNotEmpty(assertable,actual,diagnostic)
```

## Description

`assertNotEmpty(assertable,actual)` asserts that `actual` is a non-empty MATLAB value.

`assertNotEmpty(assertable,actual,diagnostic)` also displays the diagnostic information in `diagnostic` upon a failure.

## Tips

- This method is functionally equivalent to:

```
import matlab.unittest.constraints.IsEmpty;
assertable.assertThat(actual, ~IsEmpty());
```

There exists more functionality when using the `IsEmpty` constraint directly via `assertThat`.

## Input Arguments

### **assertable**

The `matlab.unittest.TestCase` instance which is used to pass or fail the assertion in conjunction with the test running framework.

### **actual**

The value to test.

### **diagnostic**

Diagnostic information to display upon a failure, specified as one of the following:

- string
- function handle
- `matlab.unittest.diagnostics.Diagnostic` object

Diagnostic values can be nonscalar. For more information, see `matlab.unittest.diagnostics.Diagnostic`.

# matlab.unittest.qualifications.Assertable.assertNotEmpty

---

**Examples**      See examples for `verifyNotEmpty`.

**See Also**      `assertThat` | `assertEmpty` | `isempty`



# matlab.unittest.qualifications.Assertable.assertNotEqual

---

## Purpose

Assert value is not equal to specified value

## Syntax

```
assertNotEqual(assertable, actual, notExpected)
assertNotEqual(assertable, actual, notExpected, diagnostic)
```

## Description

`assertNotEqual(assertable, actual, notExpected)` asserts that `actual` is not equal to `notExpected`.

`assertNotEqual(assertable, actual, notExpected, diagnostic)` also displays the diagnostic information in `diagnostic` upon a failure.

## Tips

- This method is functionally equivalent to:

```
import matlab.unittest.constraints.IsEqualTo;
assertable.assertThat(actual, ~IsEqualTo(notExpected));
```

There exists more functionality when using the `IsEqualTo` constraint directly via `assertThat`.

## Input Arguments

### **assertable**

The `matlab.unittest.TestCase` instance which is used to pass or fail the assertion in conjunction with the test running framework.

### **actual**

The value to test.

### **notExpected**

Value to compare.

### **diagnostic**

Diagnostic information to display upon a failure, specified as one of the following:

- string
- function handle
- `matlab.unittest.diagnostics.Diagnostic` object

# matlab.unittest.qualifications.Assertable.assertNotEqual

---

Diagnostic values can be nonscalar. For more information, see `matlab.unittest.diagnostics.Diagnostic`.

**Examples**      See examples for `verifyNotEqual`.

**See Also**      `assertThat` | `assertEqual`

# matlab.unittest.qualifications.Assertable.assertNotSameHandle

---

## Purpose

Assert value is not handle to specified instance

## Syntax

```
assertNotSameHandle(assertable,actual,notExpectedHandle)
assertNotSameHandle(assertable,actual,notExpectedHandle,diagnostic)
```

## Description

`assertNotSameHandle(assertable,actual,notExpectedHandle)` asserts that `actual` is a different size and/or does not contain the same instances as the `notExpectedHandle` handle array.

`assertNotSameHandle(assertable,actual,notExpectedHandle,diagnostic)` also displays the diagnostic information in `diagnostic` upon a failure.

## Tips

- This method is functionally equivalent to:

```
import matlab.unittest.constraints.IsSameHandleAs;
assertable.assertThat(actual, ~IsSameHandleAs(notExpectedHandle));
```

There exists more functionality when using the `IsSameHandleAs` constraint directly via `assertThat`.

## Input Arguments

### **assertable**

The `matlab.unittest.TestCase` instance which is used to pass or fail the assertion in conjunction with the test running framework.

### **actual**

The value to test.

### **notExpectedHandle**

The handle array to compare.

### **diagnostic**

Diagnostic information to display upon a failure, specified as one of the following:

- string
- function handle

- `matlab.unittest.diagnostics.Diagnostic` object

Diagnostic values can be nonscalar. For more information, see `matlab.unittest.diagnostics.Diagnostic`.

## Examples

See examples for `verifyNotSameHandle`.

## See Also

`assertThat` | `assertSameHandle`

# matlab.unittest.qualifications.Assertable.assertNumElements

## Purpose

Assert value has specified element count

## Syntax

```
assertNumElements(assertable,actual,expectedElementCount)
assertNumElements(assertable,actual,expectedElementCount,diagnostic)
```

## Description

`assertNumElements(assertable,actual,expectedElementCount)` asserts that `actual` is a MATLAB array with `expectedElementCount` number of elements.

`assertNumElements(assertable,actual,expectedElementCount,diagnostic)` also displays the diagnostic information in `diagnostic` upon a failure.

## Tips

- This method is functionally equivalent to:

```
import matlab.unittest.constraints.HasElementCount;
assertable.assertThat(actual, HasElementCount(expectedElementCount))
```

There exists more functionality when using the `HasElementCount` constraint directly via `assertThat`.

## Input Arguments

### **assertable**

The `matlab.unittest.TestCase` instance which is used to pass or fail the assertion in conjunction with the test running framework.

### **actual**

The value to test.

### **expectedElementCount**

The expected number of elements in the array.

### **diagnostic**

Diagnostic information to display upon a failure, specified as one of the following:

- string
- function handle

# matlab.unittest.qualifications.Assertable.assertNumElements

---

- `matlab.unittest.diagnostics.Diagnostic` object

Diagnostic values can be nonscalar. For more information, see `matlab.unittest.diagnostics.Diagnostic`.

## Examples

See examples for `verifyNumElements`.

## See Also

`assertThat` | `assertSize` | `assertLength` | `numel`

# matlab.unittest.qualifications.Assertable.assertReturnsTrue

**Purpose** Assert function returns true when evaluated

**Syntax** `assertReturnsTrue(assertable,actual)`  
`assertReturnsTrue(assertable,actual,diagnostic)`

**Description** `assertReturnsTrue(assertable,actual)` asserts that `actual` is a function handle that returns a scalar logical whose value is true.  
`assertReturnsTrue(assertable,actual,diagnostic)` also displays the diagnostic information in `diagnostic` upon a failure.

**Tips**

- It is a shortcut for quick custom comparison functionality that can be defined quickly, and possibly inline. It can be preferable over simply evaluating the function directly and using `assertTrue` because the function handle will be shown in the diagnostics, thus providing more insight into the failure condition which is lost when using `assertTrue`.
- This method is functionally equivalent to:

```
import matlab.unittest.constraints.ReturnsTrue;
assertable.assertThat(actual, ReturnsTrue());
```

There exists more functionality when using the `ReturnsTrue` constraint directly via `assertThat`.

## Input Arguments

### **assertable**

The `matlab.unittest.TestCase` instance which is used to pass or fail the assertion in conjunction with the test running framework.

### **actual**

The function handle to test.

### **diagnostic**

Diagnostic information to display upon a failure, specified as one of the following:

- string

# matlab.unittest.qualifications.Assertable.assertReturnsTrue

---

- function handle
- matlab.unittest.diagnostics.Diagnostic object

Diagnostic values can be nonscalar. For more information, see `matlab.unittest.diagnostics.Diagnostic`.

## Examples

See examples for `verifyReturnsTrue`.

## See Also

`assertThat` | `assertTrue`



# matlab.unittest.qualifications.Assertable.assertSameHandle

## Purpose

Assert two values are handles to same instance

## Syntax

```
assertSameHandle(assertable,actual,expectedHandle)
assertSameHandle(assertable,actual,expectedHandle,diagnostic)
```

## Description

`assertSameHandle(assertable,actual,expectedHandle)` asserts that `actual` is the same size and contains the same instances as the `expectedHandle` handle array.

`assertSameHandle(assertable,actual,expectedHandle,diagnostic)` also displays the diagnostic information in `diagnostic` upon a failure.

## Tips

- This method is functionally equivalent to:

```
import matlab.unittest.constraints.IsSameHandleAs;
assertable.assertThat(actual, IsSameHandleAs(expectedHandle));
```

There exists more functionality when using the `IsSameHandleAs` constraint directly via `assertThat`.

## Input Arguments

### **assertable**

The `matlab.unittest.TestCase` instance which is used to pass or fail the assertion in conjunction with the test running framework.

### **actual**

The value to test.

### **expectedHandle**

The expected handle array.

### **diagnostic**

Diagnostic information to display upon a failure, specified as one of the following:

- string
- function handle

# matlab.unittest.qualifications.Assertable.assertSameHandle

---

- `matlab.unittest.diagnostics.Diagnostic` object

Diagnostic values can be nonscalar. For more information, see `matlab.unittest.diagnostics.Diagnostic`.

## Examples

See examples for `verifySameHandle`.

## See Also

`assertThat` | `assertNotSameHandle` | `handle`

# matlab.unittest.qualifications.Assertable.assertSize

---

<b>Purpose</b>	Assert value has specified size
<b>Syntax</b>	<pre>assertSize(assertable,actual,expectedSize) assertSize(assertable,actual,expectedSize,diagnostic)</pre>
<b>Description</b>	<p><code>assertSize(assertable,actual,expectedSize)</code> asserts that <code>actual</code> is a MATLAB array whose size is <code>expectedSize</code>.</p> <p><code>assertSize(assertable,actual,expectedSize,diagnostic)</code> also displays the diagnostic information in <code>diagnostic</code> upon a failure.</p>
<b>Tips</b>	<ul style="list-style-type: none"><li>• This method is functionally equivalent to: <pre>import matlab.unittest.constraints.HasSize; assertable.assertThat(actual, HasSize(expectedSize));</pre><p>There exists more functionality when using the <code>HasSize</code> constraint directly via <code>assertThat</code>.</p></li></ul>
<b>Input Arguments</b>	<p><b>assertable</b> The <code>matlab.unittest.TestCase</code> instance which is used to pass or fail the assertion in conjunction with the test running framework.</p> <p><b>actual</b> The value to test.</p> <p><b>expectedSize</b> The expected sizes of each dimension the array.</p> <p><b>diagnostic</b> Diagnostic information to display upon a failure, specified as one of the following:</p> <ul style="list-style-type: none"><li>• string</li><li>• function handle</li><li>• <code>matlab.unittest.diagnostics.Diagnostic</code> object</li></ul>

# matlab.unittest.qualifications.Assertable.assertSize

---

Diagnostic values can be nonscalar. For more information, see `matlab.unittest.diagnostics.Diagnostic`.

**Examples** See examples for `verifySize`.

**See Also** `assertThat` | `assertLength` | `assertNumElements` | `size`

# matlab.unittest.qualifications.Assertable.assertSubstring

---

## Purpose

Assert string contains specified string

## Syntax

```
assertSubstring(assertable,actual,substring)
assertSubstring(assertable,actual,substring,diagnostic)
```

## Description

`assertSubstring(assertable,actual,substring)` asserts that `actual` is a string that contains `substring`.

`assertSubstring(assertable,actual,substring,diagnostic)` also displays the diagnostic information in `diagnostic` upon a failure.

## Tips

- This method is functionally equivalent to:

```
import matlab.unittest.constraints.ContainsSubstring;
assertable.assertThat(actual, ContainsSubstring(substring));
```

There exists more functionality when using the `ContainsSubstring` constraint directly via `assertThat`.

## Input Arguments

### **assertable**

The `matlab.unittest.TestCase` instance which is used to pass or fail the assertion in conjunction with the test running framework.

### **actual**

The value to test.

### **substring**

The value to match, specified as a string.

### **diagnostic**

Diagnostic information to display upon a failure, specified as one of the following:

- string
- function handle
- `matlab.unittest.diagnostics.Diagnostic` object

# matlab.unittest.qualifications.Assertable.assertSubstring

---

Diagnostic values can be nonscalar. For more information, see `matlab.unittest.diagnostics.Diagnostic`.

**Examples** See examples for `verifySubstring`.

**See Also** `assertThat` | `assertMatches` | `strfind`

# matlab.unittest.qualifications.Assertable.assertThat

---

## Purpose

Assert that value meets specified constraint

## Syntax

```
assertThat(assertable, actual, constraint)
assertThat(assertable, actual, constraint, diagnostic)
```

## Description

`assertThat(assertable, actual, constraint)` asserts that `actual` is a value that satisfies the `constraint` provided.

If the `constraint` is not satisfied, an assertion failure is produced utilizing only the framework diagnostic generated by the `constraint`.

`assertThat(assertable, actual, constraint, diagnostic)` also displays the diagnostic information in `diagnostic` upon a failure.

When using this signature, both the diagnostic information contained within `diagnostic` is used in addition to the diagnostic information provided by the `constraint`.

## Input Arguments

### **assertable**

The `matlab.unittest.TestCase` instance which is used to pass or fail the assertion in conjunction with the test running framework.

### **actual**

The value to test.

### **constraint**

### **diagnostic**

Diagnostic information to display upon a failure, specified as one of the following:

- string
- function handle
- `matlab.unittest.diagnostics.Diagnostic` object

Diagnostic values can be nonscalar. For more information, see `matlab.unittest.diagnostics.Diagnostic`.

# matlab.unittest.qualifications.Assertable.assertThat

---

## **Examples**

See examples for `verifyThat`.



# matlab.unittest.qualifications.Assertable.assertTrue

## Purpose

Assert value is true

## Syntax

```
assertTrue(assertable, actual)
assertTrue(assertable, actual, diagnostic)
```

## Description

`assertTrue(assertable, actual)` asserts that `actual` is a scalar logical with the value of true.

`assertTrue(assertable, actual, diagnostic)` also displays the diagnostic information in `diagnostic` upon a failure.

## Tips

- This method passes if and only if the actual value is a scalar logical with a value of true. Therefore, entities such as true valued arrays and non-zero doubles produce qualification failures when used in this method, despite these entities exhibiting "true-like" behavior such as triggering the execution of code inside of "if" statements.
- This method is functionally equivalent to:

```
import matlab.unittest.constraints.IsTrue;
assertable.assertThat(actual, IsTrue());
```

There exists more functionality when using the `IsTrue` constraint directly via `assertThat`.

Use of this method for performance benefits can come at the expense of less diagnostic information, and may not provide the same level of strictness adhered to by other constraints such as `IsEqualTo`. A similar approach that is generally less performant but can provide slightly better diagnostic information is the use of `assertReturnsTrue`, which at least shows the display of the function evaluated to generate the failing result.

## Input Arguments

### **assertable**

The `matlab.unittest.TestCase` instance which is used to pass or fail the assertion in conjunction with the test running framework.

### **actual**

# matlab.unittest.qualifications.Assertable.assertTrue

---

The value to test.

## **diagnostic**

Diagnostic information to display upon a failure, specified as one of the following:

- string
- function handle
- matlab.unittest.diagnostics.Diagnostic object

Diagnostic values can be nonscalar. For more information, see `matlab.unittest.diagnostics.Diagnostic`.

## **Examples**

See examples for `verifyTrue`.

## **See Also**

`assertThat` | `assertFalse` | `assertReturnsTrue`

# matlab.unittest.qualifications.Assertable.assertWarning

## Purpose

Assert function issues specified warning

## Syntax

```
assertWarning(assertable,actual,warningID)
assertWarning(assertable,actual,warningID,diagnostic)
[output1,...,outputN] = assertWarning(___)
```

## Description

`assertWarning(assertable,actual,warningID)` asserts that `actual` issues a warning with the identifier `warningID`.

`assertWarning(assertable,actual,warningID,diagnostic)` also displays the diagnostic information in `diagnostic` upon a failure.

`[output1,...,outputN] = assertWarning( ___ )` also returns the output arguments `output1,...,outputN` that are produced when invoking `actual`.

## Tips

- This method is functionally equivalent to:

```
import matlab.unittest.constraints.IssuesWarnings;
assertable.assertThat(actual, IssuesWarnings({warningID}));
```

There exists more functionality when using the `IssuesWarnings` constraint directly via `assertThat`.

## Input Arguments

### **assertable**

The `matlab.unittest.TestCase` instance which is used to pass or fail the assertion in conjunction with the test running framework.

### **actual**

The function handle to test.

### **warningID**

Warning ID, specified as a string.

### **diagnostic**

Diagnostic information to display upon a failure, specified as one of the following:

# matlab.unittest.qualifications.Assertable.assertWarning

---

- string
- function handle
- matlab.unittest.diagnostics.Diagnostic object

Diagnostic values can be nonscalar. For more information, see `matlab.unittest.diagnostics.Diagnostic`.

## Output Arguments

### **output1,...,outputN**

Output arguments, 1 through n (if any), from `actual`, returned as any type. The argument type is specified by the `actual` argument list.

## Examples

See examples for `verifyWarning`.

## See Also

`assertThat` | `assertError` | `assertWarningFree` | `warning`

# matlab.unittest.qualifications.Assertable.assertWarningFree

## Purpose

Assert function issues no warnings

## Syntax

```
assertWarningFree(assertable,actual)
assertWarningFree(assertable,actual,diagnostic)
[output1,...,outputN] = assertWarningFree(___)
```

## Description

`assertWarningFree(assertable,actual)` asserts that `actual` is a function handle that issues no warnings.

`assertWarningFree(assertable,actual,diagnostic)` also displays the diagnostic information in `diagnostic` upon a failure.

`[output1,...,outputN] = assertWarningFree( ___ )` also returns the output arguments `output1,...,outputN` that are produced when invoking `actual`.

## Tips

- This method is functionally equivalent to:

```
import matlab.unittest.constraints.IssuesNoWarnings;
assertable.assertThat(actual, IssuesNoWarnings());
```

There exists more functionality when using the `IssuesNoWarnings` constraint directly via `assertThat`.

## Input Arguments

### **assertable**

The `matlab.unittest.TestCase` instance which is used to pass or fail the assertion in conjunction with the test running framework.

### **actual**

The function handle to test.

### **diagnostic**

Diagnostic information to display upon a failure, specified as one of the following:

- string
- function handle

# matlab.unittest.qualifications.Assertable.assertWarningFree

---

- `matlab.unittest.diagnostics.Diagnostic` object

Diagnostic values can be nonscalar. For more information, see `matlab.unittest.diagnostics.Diagnostic`.

## Output Arguments

### `output1,...,outputN`

Output arguments, 1 through n (if any), from `actual`, returned as any type. The argument type is specified by the `actual` argument list.

## Examples

See examples for `verifyWarningFree`.

## See Also

`assertThat` | `assertWarning` | `warning`

# matlab.unittest.qualifications.AssertionFailedException

---

**Purpose** Exception used for assertion failures

**Description** The `AssertionFailedException` class provides an exception used for assertion failures. This class is used exclusively by the `Assertable` qualification type.

**See Also** `Assertable` | `MException`

# matlab.unittest.qualifications.Assumable

---

**Purpose** Qualification to filter test content

**Description** The `Assumable` class provides a qualification to filter test content. Apart from actions performed in the event of failures, the `Assumable` class works the same as other `matlab.unittest` qualifications.

Upon an assumption failure, the `Assumable` class informs the testing framework of the failure by throwing an `AssumptionFailedException`. The test framework then marks the test content as filtered and continues testing. Often, assumptions are used to ensure that the test is run only when certain preconditions are met. However, running the test without satisfying the preconditions does not produce a test failure. Ensure that the test content is “Exception Safe” on page 1-5361. If the failure condition is meant to produce a test failure, use assertions or verifications instead of assumptions.

The attributes specified in the `TestCase` method definition determine which tests are filtered. The following behavior occurs when the test framework encounters an assumption failure inside of a `TestCase` method:

- If you define the `TestCase` method using the `Test` attribute, the framework marks the entire method as filtered and runs subsequent test methods.
- If you define the `TestCase` method using the `TestMethodSetup` or `TestMethodTeardown` attributes, the test framework marks the method to run for that instance as filtered.
- If you define the `TestCase` method using the `TestClassSetup` or `TestClassTeardown` attributes, the test framework filters the entire `TestCase` class.

Filtering test content using assumptions does not produce test failures. Therefore, dead test code can result. Avoid this by monitoring filtered tests.



## Methods

<code>assumeClass</code>	Assume exact class of specified value
<code>assumeEmpty</code>	Assume value is empty
<code>assumeEqual</code>	Assume value is equal to specified value
<code>assumeError</code>	Assume function throws specified exception
<code>assumeFail</code>	Produce unconditional assumption failure
<code>assumeFalse</code>	Assume value is false
<code>assumeGreaterThan</code>	Assume value is greater than specified value
<code>assumeGreaterThanOrEqual</code>	Assume value is greater than or equal to specified value
<code>assumeInstanceOf</code>	Assume value is object of specified type
<code>assumeLength</code>	Assume value has specified length
<code>assumeLessThan</code>	Assume value is less than specified value
<code>assumeLessThanOrEqual</code>	Assume value is less than or equal to specified value
<code>assumeMatches</code>	Assume string matches specified regular expression
<code>assumeNotEmpty</code>	Assume value is not empty
<code>assumeNotEqual</code>	Assume value is not equal to specified value
<code>assumeNotSameHandle</code>	Assume value is not handle to specified instance

# matlab.unittest.qualifications.Assumable

---

<code>assumeNumElements</code>	Assume value has specified element count
<code>assumeReturnsTrue</code>	Assume function returns true when evaluated
<code>assumeSameHandle</code>	Assume two values are handles to same instance
<code>assumeSize</code>	Assume value has specified size
<code>assumeSubstring</code>	Assume string contains specified string
<code>assumeThat</code>	Assume value meets specified constraint
<code>assumeTrue</code>	Assume value is true
<code>assumeWarning</code>	Assume function issues specified warning
<code>assumeWarningFree</code>	Assume function issues no warnings

## Events

<code>AssumptionFailed</code>	Triggered upon failing assumption. A <code>QualificationEventData</code> object is passed to listener callback functions.
<code>AssumptionPassed</code>	Triggered upon passing assumption. A <code>QualificationEventData</code> object is passed to listener callback functions.

## Definitions

### Exception Safe

Test content is *exception safe* when all fixture teardown is performed with `addTeardown` or through the appropriate object destructors when a failure occurs. This ensures that the failure does not affect later testing due to stale fixtures.

This code is not exception safe. After an assertion failure, the test framework does not close the figure.

```
% Not exception safe
f = figure;
testCase.assertEqual(actual, expected);
close(f);
```

This code is exception safe because the test framework closes the figure in all cases.

```
% Exception safe
f = figure;
testCase.addTeardown(@close, f);
testCase.assertEqual(actual, expected);
```

However, tearing down a fixture using `addTeardown` does not guarantee code is exception safe. This code shows a failure in `assertEqual`.

```
% Not exception safe
f = figure;
testCase.assertEqual(actual, expected);
testCase.addTeardown(@close, f);
```

## Copy Semantics

Handle. To learn how handle classes affect copy operations, see [Copying Objects in the MATLAB documentation](#).

## Examples

### Write TestClassSetup Method Using Assumptions

Assumptions assure that a test runs only when certain preconditions are satisfied and when such an event should not produce a test failure. When an assumption failure occurs, the test is marked as filtered.

# matlab.unittest.qualifications.Assumable

---

Create `IsSupportedTest` test case. Refer to the following `IsSupportedTest` test case in the subsequent steps in this example, which highlight specific functions in the file.

## IsSupportedTest Class Definition File

```
classdef IsSupportedTest < matlab.unittest.TestCase
 methods(TestClassSetup)
 function TestPlatform(testcase)
 testcase.assumeFalse(ispc,...
 'Do not run any of these tests on Windows.');
```

end

```
 end
 end
 methods(Test)
 function test1(testcase)
 %write test code here
 end
 end
end
```

To execute the MATLAB commands in this example, add the `IsSupportedTest.m` file to a folder on your MATLAB path.

Write `Test to Verify Platform`. All tests in this test case must run on UNIX platforms only. The `TestPlatform` function uses the `assumeFalse` method to test if MATLAB is running on a Windows platform. If it is, the test fails.

```
function TestPlatform(testcase)
 testcase.assumeFalse(ispc,...
 'Do not run any of these tests on Windows.');
```

end

Make `TestPlatform` a `TestClassSetup` Test. To make the `TestPlatform` test a precondition, add it inside the `methods (TestClassSetup)` block.

Run the test case. Create a test case object and run the tests on a Windows platform.

```
tc = IsSupportedTest;
res = tc.run;
```

Running IsSupportedTest

```
=====
All tests in IsSupportedTest were filtered.
 Test Diagnostic: Do not run any of these tests on Windows.
 Details
=====
```

Done IsSupportedTest

Failure Summary:

Name	Failed	Incomplete	Reason(s)
IsSupportedTest/test1		X	Filtered by assumption

The test(s) were filtered, and did not run (marked Incomplete).

For more information, click the [Details link](#).

```
=====
The TestClassSetup or TestClassTeardown for IsSupportedTest was filtered.
All tests in this class were also filtered as a result.
```

```

Test Diagnostic:
```

```

Do not run any of these tests on Windows.
```

```

Framework Diagnostic:
```

# matlab.unittest.qualifications.Assumable

---

```

assumeFalse failed.
--> The value must evaluate to "false".

Actual Value:
 1

Stack Information:

In C:\Program Files\MATLAB\R2013a\toolbox\matlab\testframework\+matlab\unittest\qualifications\Assumable.m (Assumable.assumeFalse) at 4
In c:\work\IsSupportedTest.m (IsSupportedTest.TestPlatform) at 4
=====
```

The link to `IsSupportedTest.TestPlatform` under Stack Information takes you to the failed `assumeFalse` method.

## See Also

[TestCase](#) | [Verifiable](#) | [FatalAssertable](#) | [Assertable](#) | [matlab.unittest.qualifications](#) | [QualificationEventData](#)

## Concepts

- “Dynamically Filtered Tests”

# matlab.unittest.qualifications.Assumable.assumeClass

## Purpose

Assume exact class of specified value

## Syntax

```
assumeClass(assumable,actual,className)
assumeClass(assumable,actual,metaClass)
assumeClass(____,diagnostic)
```

## Description

`assumeClass(assumable,actual,className)` assumes that `actual` is a MATLAB value whose class is the class specified by `className`.

`assumeClass(assumable,actual,metaClass)` assumes that `actual` is a MATLAB value whose class is the class specified by the `meta.class` instance `metaClass`. The instance must be an exact class match. See `assumeInstanceOf` to assume inclusion in a class hierarchy.

`assumeClass( ____,diagnostic)` also displays the diagnostic information in `diagnostic` upon a failure.

## Tips

- The method is functionally equivalent to:

```
import matlab.unittest.constraints.IsOfClass;
assumable.assumeThat(actual, IsOfClass(className));
assumable.assumeThat(actual, IsOfClass(metaClass));
```

There exists more functionality when using the `IsOfClass` constraint directly via `assumeThat`.

## Input Arguments

### **assumable**

The `matlab.unittest.TestCase` instance which is used to pass or fail the assumption in conjunction with the test running framework.

### **actual**

The value to test.

### **className**

Name of class, specified as a string.

### **metaClass**

# matlab.unittest.qualifications.Assumable.assumeClass

---

An instance of `meta.class`.

## **diagnostic**

Diagnostic information to display upon a failure, specified as one of the following:

- string
- function handle
- `matlab.unittest.diagnostics.Diagnostic` object

Diagnostic values can be nonscalar. For more information, see `matlab.unittest.diagnostics.Diagnostic`.

## **Examples**

See examples for `verifyClass`.

## **See Also**

`assumeThat` | `assumeInstanceOf`



# matlab.unittest.qualifications.Assumable.assumeEmpty

---

## Purpose

Assume value is empty

## Syntax

```
assumeEmpty(assumable,actual)
assumeEmpty(assumable,actual,diagnostic)
```

## Description

`assumeEmpty(assumable,actual)` assumes that `actual` is an empty MATLAB value.

`assumeEmpty(assumable,actual,diagnostic)` also displays the diagnostic information in `diagnostic` upon a failure.

## Tips

- This method is functionally equivalent to:

```
import matlab.unittest.constraints.IsEmpty;
assumable.assumeThat(actual, IsEmpty());
```

There exists more functionality when using the `IsEmpty` constraint directly via `assumeThat`.

## Input Arguments

### **assumable**

The `matlab.unittest.TestCase` instance which is used to pass or fail the assumption in conjunction with the test running framework.

### **actual**

The value to test.

### **diagnostic**

Diagnostic information to display upon a failure, specified as one of the following:

- string
- function handle
- `matlab.unittest.diagnostics.Diagnostic` object

# matlab.unittest.qualifications.Assumable.assumeEmpty

---

Diagnostic values can be nonscalar. For more information, see `matlab.unittest.diagnostics.Diagnostic`.

**Examples** See examples for `verifyEmpty`.

**See Also** `assumeThat` | `assumeNotEmpty` | `isempty`

# matlab.unittest.qualifications.Assumable.assumeEqual

## Purpose

Assume value is equal to specified value

## Syntax

```
assumeEqual(assumable,actual,expected)
assumeEqual(____,Name,Value)
assumeEqual(____,diagnostic)
```

## Description

`assumeEqual(assumable,actual,expected)` assumes that `actual` is strictly equal to `expected`.

`assumeEqual( ____,Name,Value)` assumes equality with additional options specified by one or more `Name,Value` pair arguments.

`assumeEqual( ____,diagnostic)` also displays the diagnostic information in `diagnostic` upon a failure.

## Tips

- This method is functionally equivalent to any of the following:

```
import matlab.unittest.constraints.IsEqualTo;
assumable.assumeThat(actual, IsEqualTo(expected));
```

```
import matlab.unittest.constraints.IsEqualTo;
import matlab.unittest.constraints.AbsoluteTolerance;
assumable.assumeThat(actual, IsEqualTo(expected, ...
 'Within', AbsoluteTolerance(abstol)));
```

```
import matlab.unittest.constraints.IsEqualTo;
import matlab.unittest.constraints.RelativeTolerance;
assumable.assumeThat(actual, IsEqualTo(expected, ...
 'Within', RelativeTolerance(reltol)));
```

```
import matlab.unittest.constraints.IsEqualTo;
import matlab.unittest.constraints.AbsoluteTolerance;
import matlab.unittest.constraints.RelativeTolerance;
assumable.assumeThat(actual, IsEqualTo(expected, ...
 'Within', AbsoluteTolerance(abstol) | RelativeTolerance(reltol))
```

# matlab.unittest.qualifications.Assumable.assumeEqual

---

There exists more functionality when using the `IsEqualTo`, `RelativeTolerance`, and `IsEqualTo` constraints directly via `assumeThat`.

## Input Arguments

### **assumable**

The `matlab.unittest.TestCase` instance which is used to pass or fail the assumption in conjunction with the test running framework.

### **actual**

The value to test.

### **expected**

Expected value.

### **diagnostic**

Diagnostic information to display upon a failure, specified as one of the following:

- string
- function handle
- `matlab.unittest.diagnostics.Diagnostic` object

Diagnostic values can be nonscalar. For more information, see `matlab.unittest.diagnostics.Diagnostic`.

## **Name-Value Pair Arguments**

Specify optional comma-separated pairs of `Name`, `Value` arguments. `Name` is the argument name and `Value` is the corresponding value. `Name` must appear inside single quotes ( ' '). You can specify several name and value pair arguments in any order as `Name1,Value1,...,NameN,ValueN`.

**'AbsTol'**

**'RelTol'**

# matlab.unittest.qualifications.Assumable.assumeEqual

---

**Examples**      See examples for `verifyEqual`.

**See Also**      `assumeThat` | `assumeNotEqual`

# matlab.unittest.qualifications.Assumable.assumeError

---

**Purpose** Assume function throws specified exception

**Syntax**

```
assumeError(assumable,actual,identifier)
assumeError(assumable,actual,metaClass)
assumeError(____,diagnostic)
```

**Description** `assumeError(assumable,actual,identifier)` assumes that `actual` is a function handle that throws an exception with an error identifier that is equal to `identifier`.

`assumeError(assumable,actual,metaClass)` assumes that `actual` is a function handle that throws an exception whose type is defined by the `meta.class` instance specified in `metaClass`. This method does not require the instance to be an exact class match, but rather it must be in the specified class hierarchy, and that hierarchy must include the `MException` class.

`assumeError( ____,diagnostic)` also displays the diagnostic information in `diagnostic` upon a failure.

**Tips**

- This method is functionally equivalent to:

```
import matlab.unittest.constraints.Throws;
assumable.assumeThat(actual, Throws(identifier));
assumable.assumeThat(actual, Throws(metaClass));
```

There exists more functionality when using the `Throws` constraint directly via `assumeThat`.

## Input Arguments

### **assumable**

The `matlab.unittest.TestCase` instance which is used to pass or fail the assumption in conjunction with the test running framework.

### **actual**

The value to test.

### **identifier**

# matlab.unittest.qualifications.Assumable.assumeError

---

Error identifier, specified as a string.

## **metaClass**

An instance of meta.class.

## **diagnostic**

Diagnostic information to display upon a failure, specified as one of the following:

- string
- function handle
- matlab.unittest.diagnostics.Diagnostic object

Diagnostic values can be nonscalar. For more information, see `matlab.unittest.diagnostics.Diagnostic`.

## **Examples**

See examples for `verifyError`.

## **See Also**

`assumeThat` | `assumeWarning` | `MException` | `error`

# matlab.unittest.qualifications.Assumable.assumeFail

---

<b>Purpose</b>	Produce unconditional assumption failure
<b>Syntax</b>	<code>assumeFail(assumable)</code> <code>assumeFail(assumable,diagnostic)</code>
<b>Description</b>	<code>assumeFail(assumable)</code> produces an unconditional assumption failure when encountered.  <code>assumeFail(assumable,diagnostic)</code> also displays the diagnostic information in <code>diagnostic</code> upon a failure.
<b>Input Arguments</b>	<p><b>assumable</b></p> <p>The <code>matlab.unittest.TestCase</code> instance which is used to pass or fail the assumption in conjunction with the test running framework.</p> <p><b>diagnostic</b></p> <p>Diagnostic information to display upon a failure, specified as one of the following:</p> <ul style="list-style-type: none"><li>• string</li><li>• function handle</li><li>• <code>matlab.unittest.diagnostics.Diagnostic</code> object</li></ul> <p>Diagnostic values can be nonscalar. For more information, see <code>matlab.unittest.diagnostics.Diagnostic</code>.</p>
<b>Examples</b>	See examples for <code>verifyFail</code> .



# matlab.unittest.qualifications.Assumable.assumeFalse

## Purpose

Assume value is false

## Syntax

```
assumeFalse(assumable, actual)
assumeFalse(assumable, actual, diagnostic)
```

## Description

`assumeFalse(assumable, actual)` assumes that `actual` is a scalar logical with the value of false.

`assumeFalse(assumable, actual, diagnostic)` also displays the diagnostic information in `diagnostic` upon a failure.

## Tips

- This method passes if and only if the actual value is a scalar logical with a value of false. Therefore, entities such as empty arrays, false valued arrays, and zero doubles produce failures when used in this method, despite these entities exhibiting "false-like" behavior such as bypassing the execution of code inside of "if" statements.
- This method is functionally equivalent to:

```
import matlab.unittest.constraints.IsFalse;
assumable.assumeThat(actual,.IsFalse());
```

There exists more functionality when using the `IsFalse` constraint directly via `assumeThat`.

- Unlike `assumeTrue`, this method may create a new constraint for each call. For performance critical uses, consider using `assumeTrue`.

## Input Arguments

### **assumable**

The `matlab.unittest.TestCase` instance which is used to pass or fail the assumption in conjunction with the test running framework.

### **actual**

The value to test.

### **diagnostic**

# matlab.unittest.qualifications.Assumable.assumeFalse

---

Diagnostic information to display upon a failure, specified as one of the following:

- string
- function handle
- `matlab.unittest.diagnostics.Diagnostic` object

Diagnostic values can be nonscalar. For more information, see `matlab.unittest.diagnostics.Diagnostic`.

## Examples

For examples, see `verifyFalse`.

## See Also

`assumeThat` | `assumeTrue`

# matlab.unittest.qualifications.Assumable.assumeGreaterThan

---

## Purpose

Assume value is greater than specified value

## Syntax

```
assumeGreaterThan(assumable,actual,floor)
assumeGreaterThan(assumable,actual,floor,diagnostic)
```

## Description

`assumeGreaterThan(assumable,actual,floor)` assumes that all elements of `actual` are greater than all the elements of `floor`.

`assumeGreaterThan(assumable,actual,floor,diagnostic)` also displays the diagnostic information in `diagnostic` upon a failure

## Tips

- This method is functionally equivalent to:

```
import matlab.unittest.constraints.IsGreaterThan;
assumable.assumeThat(actual, IsGreaterThan(floor));
```

There exists more functionality when using the `IsGreaterThan` constraint directly via `assumeThat`.

## Input Arguments

### **assumable**

The `matlab.unittest.TestCase` instance which is used to pass or fail the assumption in conjunction with the test running framework.

### **actual**

The value to test. `actual` must be the same size as `floor` unless either one is scalar, at which point scalar expansion occurs.

### **floor**

Minimum value, exclusive.

### **diagnostic**

Diagnostic information to display upon a failure, specified as one of the following:

- string

# matlab.unittest.qualifications.Assumable.assumeGreaterThan

---

- function handle
- matlab.unittest.diagnostics.Diagnostic object

Diagnostic values can be nonscalar. For more information, see `matlab.unittest.diagnostics.Diagnostic`.

## Examples

See examples for `verifyGreaterThan`.

## See Also

`assumeThat` | `assumeGreaterThanOrEqual` |  
`assumeLessThanOrEqual` | `assumeLessThan` | `gt` |  
`matlab.unittest.constraints.IsGreaterThan` |  
`matlab.unittest.diagnostics.Diagnostic`

## Purpose

Assume value is greater than or equal to specified value

## Syntax

```
assumeGreaterThanOrEqual(assumable,actual,floor)
assumeGreaterThanOrEqual(assumable,actual,floor,diagnostic)
```

## Description

`assumeGreaterThanOrEqual(assumable,actual,floor)` assumes that all elements of `actual` are greater than or equal to all the elements of `floor`.

`assumeGreaterThanOrEqual(assumable,actual,floor,diagnostic)` also displays the diagnostic information in `diagnostic` upon a failure.

## Tips

- This method is functionally equivalent to:

```
import matlab.unittest.constraints.IsGreaterThanOrEqualTo;
assumable.assumeThat(actual, IsGreaterThanOrEqualTo(floor));
```

There exists more functionality when using the `IsGreaterThanOrEqualTo` constraint directly via `assumeThat`.

## Input Arguments

### **assumable**

The `matlab.unittest.TestCase` instance which is used to pass or fail the assumption in conjunction with the test running framework.

### **actual**

The value to test. `actual` must be the same size as `floor` unless either one is scalar, at which point scalar expansion occurs.

### **floor**

Minimum value.

### **diagnostic**

Diagnostic information to display upon a failure, specified as one of the following:

- string

- function handle
- matlab.unittest.diagnostics.Diagnostic object

Diagnostic values can be nonscalar. For more information, see `matlab.unittest.diagnostics.Diagnostic`.

## Examples

See examples for `verifyGreaterThanOrEqual`.

## See Also

`assumeThat` | `assumeGreaterThan` |  
`assumeLessThanOrEqual` | `assumeLessThan` | `ge` |  
`matlab.unittest.constraints.IsGreaterThanOrEqualTo` |  
`matlab.unittest.diagnostics.Diagnostic`

# matlab.unittest.qualifications.Assumable.assumeInstanceOf

**Purpose** Assume value is object of specified type

**Syntax**

```
assumeInstanceOf(assumable,actual,className)
assumeInstanceOf(assumable,actual,metaClass)
assumeInstanceOf(___,diagnostic)
```

**Description**

`assumeInstanceOf(assumable,actual,className)` assumes that `actual` is a MATLAB value whose class is the class specified by `className`.

`assumeInstanceOf(assumable,actual,metaClass)` `actual` is a MATLAB value whose class is the class specified by the `meta.class` instance `metaClass`.

`assumeInstanceOf(___,diagnostic)` also displays the diagnostic information in `diagnostic` upon a failure.

**Tips**

- This method is functionally equivalent to:

```
import matlab.unittest.constraints.IsInstanceOf;
assumable.assumeThat(actual, IsInstanceOf(className));
assumable.assumeThat(actual, IsInstanceOf(metaClass));
```

There exists more functionality when using the `IsInstanceOf` constraint directly via `assumeThat`.

## Input Arguments

### **assumable**

The `matlab.unittest.TestCase` instance which is used to pass or fail the assumption in conjunction with the test running framework.

### **actual**

The value to test.

### **className**

Name of class, specified as a string.

### **metaClass**

# matlab.unittest.qualifications.Assumable.assumeInstanceOf

---

An instance of `meta.class`.

## **diagnostic**

Diagnostic information to display upon a failure, specified as one of the following:

- string
- function handle
- `matlab.unittest.diagnostics.Diagnostic` object

Diagnostic values can be nonscalar. For more information, see `matlab.unittest.diagnostics.Diagnostic`.

## **Examples**

See examples for `verifyInstanceOf`.

## **See Also**

`assumeThat` | `assumeClass` | `isa`



# matlab.unittest.qualifications.Assumable.assumeLength

---

## Purpose

Assume value has specified length

## Syntax

```
assumeLength(assumable,actual,expectedLength)
assumeLength(assumable,actual,expectedLength,diagnostic)
```

## Description

`assumeLength(assumable,actual,expectedLength)` assumes that `actual` is a MATLAB array whose length is `expectedLength`.

`assumeLength(assumable,actual,expectedLength,diagnostic)` also displays the diagnostic information in `diagnostic` upon a failure.

## Tips

- This method is functionally equivalent to:

```
import matlab.unittest.constraints.HasLength;
assumable.assumeThat(actual, HasLength(expectedLength));
```

There exists more functionality when using the `HasLength` constraint directly via `assumeThat`.

## Input Arguments

### **assumable**

The `matlab.unittest.TestCase` instance which is used to pass or fail the assumption in conjunction with the test running framework.

### **actual**

The value to test.

### **expectedLength**

The length of an array is defined as the largest dimension of that array.

### **diagnostic**

Diagnostic information to display upon a failure, specified as one of the following:

- string

# matlab.unittest.qualifications.Assumable.assumeLength

---

- function handle
- matlab.unittest.diagnostics.Diagnostic object

Diagnostic values can be nonscalar. For more information, see `matlab.unittest.diagnostics.Diagnostic`.

## Examples

See examples for `verifyLength`.

## See Also

`assumeThat` | `assumeSize` | `assumeNumElements` | `length`

## Purpose

Assume value is less than specified value

## Syntax

```
assumeLessThan(assumable,actual,ceiling)
assumeLessThan(assumable,actual,ceiling,diagnostic)
```

## Description

`assumeLessThan(assumable,actual,ceiling)` assumes that all elements of `actual` are less than all the elements of `ceiling`.

`assumeLessThan(assumable,actual,ceiling,diagnostic)` also displays the diagnostic information in `diagnostic` upon a failure.

## Tips

- This method is functionally equivalent to:

```
import matlab.unittest.constraints.IsLessThan;
assumable.assumeThat(actual, IsLessThan(ceiling));
```

There exists more functionality when using the `IsLessThan` constraint directly via `assumeThat`.

## Input Arguments

### **assumable**

The `matlab.unittest.TestCase` instance which is used to pass or fail the assumption in conjunction with the test running framework.

### **actual**

The value to test. `actual` must be the same size as `ceiling` unless either one is scalar, at which point scalar expansion occurs.

### **ceiling**

Maximum value, exclusive.

### **diagnostic**

Diagnostic information to display upon a failure, specified as one of the following:

- string

# matlab.unittest.qualifications.Assumable.assumeLessThan

---

- function handle
- matlab.unittest.diagnostics.Diagnostic object

Diagnostic values can be nonscalar. For more information, see `matlab.unittest.diagnostics.Diagnostic`.

## Examples

See examples for `verifyLessThan`.

## See Also

`assumeThat` | `assumeLessThanOrEqual` |  
`assumeGreaterThan` | `assumeGreaterThanOrEqual` |  
`lt` | `matlab.unittest.constraints.IsLessThan` |  
`matlab.unittest.diagnostics.Diagnostic`

## Purpose

Assume value is less than or equal to specified value

## Syntax

```
assumeLessThanOrEqualTo(assumable,actual,ceiling)
assumeLessThanOrEqualTo(assumable,actual,ceiling,diagnostic)
```

## Description

`assumeLessThanOrEqualTo(assumable,actual,ceiling)` assumes that all elements of `actual` are less than or equal to all the elements of `ceiling`.

`assumeLessThanOrEqualTo(assumable,actual,ceiling,diagnostic)` also displays the diagnostic information in `diagnostic` upon a failure.

## Tips

- This method is functionally equivalent to:

```
import matlab.unittest.constraints.IsLessThanOrEqualTo;
assumable.assumeThat(actual, IsLessThanOrEqualTo(ceiling));
```

There exists more functionality when using the `IsLessThanOrEqualTo` constraint directly via `assumeThat`.

## Input Arguments

### **assumable**

The `matlab.unittest.TestCase` instance which is used to pass or fail the assumption in conjunction with the test running framework.

### **actual**

The value to test. `actual` must be the same size as `ceiling` unless either one is scalar, at which point scalar expansion occurs.

### **ceiling**

Maximum value.

### **diagnostic**

Diagnostic information to display upon a failure, specified as one of the following:

- string

- function handle
- matlab.unittest.diagnostics.Diagnostic object

Diagnostic values can be nonscalar. For more information, see `matlab.unittest.diagnostics.Diagnostic`.

## Examples

See examples for `verifyLessThanOrEqual`.

## See Also

`assumeThat` | `assumeLessThan` | `assumeGreaterThan`  
| `assumeGreaterThanOrEqual` | `le` |  
`matlab.unittest.constraints.IsLessThanOrEqualTo` |  
`matlab.unittest.diagnostics.Diagnostic`

# matlab.unittest.qualifications.Assumable.assumeMatches

---

## Purpose

Assume string matches specified regular expression

## Syntax

```
assumeMatches(assumable,actual,expression)
assumeMatches(assumable,actual,expression,diagnostic)
```

## Description

`assumeMatches(assumable,actual,expression)` assumes that `actual` is a string that matches the regular expression defined by `expression`.

`assumeMatches(assumable,actual,expression,diagnostic)` also displays the diagnostic information in `diagnostic` upon a failure.

## Tips

- This method is functionally equivalent to:

```
import matlab.unittest.constraints.Matches;
assumable.assumeThat(actual, Matches(expression));
```

There exists more functionality when using the `Matches` constraint directly via `assumeThat`.

## Input Arguments

### **assumable**

The `matlab.unittest.TestCase` instance which is used to pass or fail the assumption in conjunction with the test running framework.

### **actual**

The string to test.

### **expression**

The value to match, specified as a regular expression.

### **diagnostic**

Diagnostic information to display upon a failure, specified as one of the following:

- string

# matlab.unittest.qualifications.Assumable.assumeMatches

---

- function handle
- matlab.unittest.diagnostics.Diagnostic object

Diagnostic values can be nonscalar. For more information, see `matlab.unittest.diagnostics.Diagnostic`.

## Examples

See examples for `verifyMatches`.

## See Also

`assumeThat` | `assumeSubstring` | `regexp`



**Purpose** Assume value is not empty

**Syntax** `assumeNotEmpty(assumable,actual)`  
`assumeNotEmpty(assumable,actual,diagnostic)`

**Description** `assumeNotEmpty(assumable,actual)` assumes that `actual` is a non-empty MATLAB value.  
`assumeNotEmpty(assumable,actual,diagnostic)` also displays the diagnostic information in `diagnostic` upon a failure.

**Tips** • This method is functionally equivalent to:

```
import matlab.unittest.constraints.IsEmpty;
assumable.assumeThat(actual, ~IsEmpty());
```

There exists more functionality when using the `IsEmpty` constraint directly via `assumeThat`.

## Input Arguments

### **assumable**

The `matlab.unittest.TestCase` instance which is used to pass or fail the assumption in conjunction with the test running framework.

### **actual**

The value to test.

### **diagnostic**

Diagnostic information to display upon a failure, specified as one of the following:

- string
- function handle
- `matlab.unittest.diagnostics.Diagnostic` object

# matlab.unittest.qualifications.Assumable.assumeNotEmpty

---

Diagnostic values can be nonscalar. For more information, see `matlab.unittest.diagnostics.Diagnostic`.

**Examples** See examples for `verifyNotEmpty`.

**See Also** `assumeThat` | `assumeEmpty` | `isempty`

## Purpose

Assume value is not equal to specified value

## Syntax

```
assumeNotEqual(assumable,actual,notExpected)
assumeNotEqual(assumable,actual,notExpected,diagnostic)
```

## Description

`assumeNotEqual(assumable,actual,notExpected)` assumes that `actual` is not equal to `notExpected`.

`assumeNotEqual(assumable,actual,notExpected,diagnostic)` also displays the diagnostic information in `diagnostic` upon a failure.

## Tips

- This method is functionally equivalent to:

```
import matlab.unittest.constraints.IsEqualTo;
assumable.assumeThat(actual, ~IsEqualTo(notExpected));
```

There exists more functionality when using the `IsEqualTo` constraint directly via `assumeThat`.

## Input Arguments

### **assumable**

The `matlab.unittest.TestCase` instance which is used to pass or fail the assumption in conjunction with the test running framework.

### **actual**

The value to test.

### **notExpected**

Value to compare.

### **diagnostic**

Diagnostic information to display upon a failure, specified as one of the following:

- string
- function handle

# matlab.unittest.qualifications.Assumable.assumeNotEqual

---

- `matlab.unittest.diagnostics.Diagnostic` object

Diagnostic values can be nonscalar. For more information, see `matlab.unittest.diagnostics.Diagnostic`.

**Examples** See examples for `verifyNotEqual`.

**See Also** `assumeThat` | `assumeEqual`

# matlab.unittest.qualifications.Assumable.assumeNotSame

---

## Purpose

Assume value is not handle to specified instance

## Syntax

```
assumeNotSameHandle(actual,notExpectedHandle)
assumeNotSameHandle(actual,notExpectedHandle,diagnostic)
```

## Description

`assumeNotSameHandle(actual,notExpectedHandle)` assumes that `actual` is a different size and/or does not contain the same instances as the `notExpectedHandle` handle array.

`assumeNotSameHandle(actual,notExpectedHandle,diagnostic)` also displays the diagnostic information in `diagnostic` upon a failure.

## Tips

- This method is functionally equivalent to:

```
import matlab.unittest.constraints.IsSameHandleAs;
assumable.assumeThat(actual, ~IsSameHandleAs(notExpectedHandle));
```

There exists more functionality when using the `IsSameHandleAs` constraint directly via `assumeThat`.

## Input Arguments

### **assumable**

The `matlab.unittest.TestCase` instance which is used to pass or fail the assumption in conjunction with the test running framework.

### **actual**

The value to test.

### **notExpectedHandle**

The handle array to compare.

### **diagnostic**

Diagnostic information to display upon a failure, specified as one of the following:

- string

# matlab.unittest.qualifications.Assumable.assumeNotSameHandle

---

- function handle
- matlab.unittest.diagnostics.Diagnostic object

Diagnostic values can be nonscalar. For more information, see `matlab.unittest.diagnostics.Diagnostic`.

## Examples

See examples for `verifyNotSameHandle`.

## See Also

`assumeThat` | `assumeSameHandle`

# matlab.unittest.qualifications.Assumable.assumeNumElements

---

## Purpose

Assume value has specified element count

## Syntax

```
assumeNumElements(assumable,actual,expectedElementCount)
assumeNumElements(assumable,actual,expectedElementCount,diagnostic)
```

## Description

`assumeNumElements(assumable,actual,expectedElementCount)` assumes that `actual` is a MATLAB array with `expectedElementCount` number of elements.

`assumeNumElements(assumable,actual,expectedElementCount,diagnostic)` also displays the diagnostic information in `diagnostic` upon a failure.

## Tips

- This method is functionally equivalent to:

```
import matlab.unittest.constraints.HasElementCount;
assumable.assumeThat(actual, HasElementCount(expectedElementCount))
```

There exists more functionality when using the `HasElementCount` constraint directly via `assumeThat`.

## Input Arguments

### **assumable**

The `matlab.unittest.TestCase` instance which is used to pass or fail the assumption in conjunction with the test running framework.

### **actual**

The value to test.

### **expectedElementCount**

The expected number of elements in the array.

### **diagnostic**

Diagnostic information to display upon a failure, specified as one of the following:

- string

# matlab.unittest.qualifications.Assumable.assumeNumElements

---

- function handle
- matlab.unittest.diagnostics.Diagnostic object

Diagnostic values can be nonscalar. For more information, see `matlab.unittest.diagnostics.Diagnostic`.

## Examples

See examples for `verifyNumElements`.

## See Also

`assumeThat` | `assumeSize` | `assumeLength` | `numel`



# matlab.unittest.qualifications.Assumable.assumeReturnsTrue

## Purpose

Assume function returns true when evaluated

## Syntax

```
assumeReturnsTrue(assumable,actual)
assumeReturnsTrue(assumable,actual,diagnostic)
```

## Description

`assumeReturnsTrue(assumable,actual)` assumes that `actual` is a function handle that returns a scalar logical whose value is true.

`assumeReturnsTrue(assumable,actual,diagnostic)` also displays the diagnostic information in `diagnostic` upon a failure.

## Tips

- It is a shortcut for quick custom comparison functionality that can be defined quickly, and possibly inline. It can be preferable over simply evaluating the function directly and using `assumeTrue` because the function handle will be shown in the diagnostics, thus providing more insight into the failure condition which is lost when using `assumeTrue`.
- This method is functionally equivalent to:

```
import matlab.unittest.constraints.ReturnsTrue;
assumable.assumeThat(actual, ReturnsTrue());
```

There exists more functionality when using the `ReturnsTrue` constraint directly via `assumeThat`.

## Input Arguments

### **assumable**

The `matlab.unittest.TestCase` instance which is used to pass or fail the assumption in conjunction with the test running framework.

### **actual**

The function handle to test.

### **diagnostic**

Diagnostic information to display upon a failure, specified as one of the following:

# matlab.unittest.qualifications.Assumable.assumeReturnsTrue

---

- string
- function handle
- matlab.unittest.diagnostics.Diagnostic object

Diagnostic values can be nonscalar. For more information, see `matlab.unittest.diagnostics.Diagnostic`.

## Examples

See examples for `verifyReturnsTrue`.

## See Also

`assumeThat` | `assumeTrue`

# matlab.unittest.qualifications.Assumable.assumeSameHandle

## Purpose

Assume two values are handles to same instance

## Syntax

```
assumeSameHandle(assumable,actual,expectedHandle)
assumeSameHandle(assumable,actual,expectedHandle,diagnostic)
```

## Description

`assumeSameHandle(assumable,actual,expectedHandle)` assumes that `actual` is the same size and contains the same instances as the `expectedHandle` handle array.

`assumeSameHandle(assumable,actual,expectedHandle,diagnostic)` also displays the diagnostic information in `diagnostic` upon a failure.

## Tips

- This method is functionally equivalent to:

```
import matlab.unittest.constraints.IsSameHandleAs;
assumable.assumeThat(actual, IsSameHandleAs(expectedHandle));
```

There exists more functionality when using the `IsSameHandleAs` constraint directly via `assumeThat`.

## Input Arguments

### **assumable**

The `matlab.unittest.TestCase` instance which is used to pass or fail the assumption in conjunction with the test running framework.

### **actual**

The value to test.

### **expectedHandle**

The expected handle array.

### **diagnostic**

Diagnostic information to display upon a failure, specified as one of the following:

- string

# matlab.unittest.qualifications.Assumable.assumeSameHandle

---

- function handle
- matlab.unittest.diagnostics.Diagnostic object

Diagnostic values can be nonscalar. For more information, see `matlab.unittest.diagnostics.Diagnostic`.

## Examples

See examples for `verifySameHandle`.

## See Also

`assumeThat` | `assumeNotSameHandle` | `handle`

# matlab.unittest.qualifications.Assumable.assumeSize

## Purpose

Assume value has specified size

## Syntax

```
assumeSize(assumable,actual,expectedSize)
assumeSize(assumable,actual,expectedSize,diagnostic)
```

## Description

`assumeSize(assumable,actual,expectedSize)` assumes that `actual` is a MATLAB array whose size is `expectedSize`.

`assumeSize(assumable,actual,expectedSize,diagnostic)` also displays the diagnostic information in `diagnostic` upon a failure.

## Tips

- This method is functionally equivalent to:

```
import matlab.unittest.constraints.HasSize;
assumable.assumeThat(actual, HasSize(expectedSize));
```

There exists more functionality when using the `HasSize` constraint directly via `assumeThat`.

## Input Arguments

### **assumable**

The `matlab.unittest.TestCase` instance which is used to pass or fail the assumption in conjunction with the test running framework.

### **actual**

The value to test.

### **expectedSize**

The expected sizes of each dimension the array.

### **diagnostic**

Diagnostic information to display upon a failure, specified as one of the following:

- string
- function handle

# matlab.unittest.qualifications.Assumable.assumeSize

---

- `matlab.unittest.diagnostics.Diagnostic` object

Diagnostic values can be nonscalar. For more information, see `matlab.unittest.diagnostics.Diagnostic`.

## Examples

See examples for `verifySize`.

## See Also

`assumeThat` | `assumeLength` | `assumeNumElements` | `size`

**Purpose** Assume string contains specified string

**Syntax** `assumeSubstring(assumable,actual,substring)`  
`assumeSubstring(assumable,actual,substring,diagnostic)`

**Description** `assumeSubstring(assumable,actual,substring)` assumes that `actual` is a string that contains `substring`.  
`assumeSubstring(assumable,actual,substring,diagnostic)` also displays the diagnostic information in `diagnostic` upon a failure.

**Tips** • This method is functionally equivalent to:

```
import matlab.unittest.constraints.ContainsSubstring;
assumable.assumeThat(actual, ContainsSubstring(substring));
```

There exists more functionality when using the `ContainsSubstring` constraint directly via `assumeThat`.

## Input Arguments

### **assumable**

The `matlab.unittest.TestCase` instance which is used to pass or fail the assumption in conjunction with the test running framework.

### **actual**

The value to test.

### **substring**

The value to match, specified as a string.

### **diagnostic**

Diagnostic information to display upon a failure, specified as one of the following:

- string
- function handle

# matlab.unittest.qualifications.Assumable.assumeSubstring

---

- `matlab.unittest.diagnostics.Diagnostic` object

Diagnostic values can be nonscalar. For more information, see `matlab.unittest.diagnostics.Diagnostic`.

## Examples

See examples for `verifySubstring`.

## See Also

`assumeThat` | `assumeMatches` | `strfind`



# matlab.unittest.qualifications.Assumable.assumeThat

---

<b>Purpose</b>	Assume value meets specified constraint
<b>Syntax</b>	<code>assumeThat(assumable,actual,constraint)</code> <code>assumeThat(assumable,actual,constraint,diagnostic)</code>
<b>Description</b>	<p><code>assumeThat(assumable,actual,constraint)</code> assumes that <code>actual</code> is a value that satisfies the <code>constraint</code> provided.</p> <p>If the constraint is not satisfied, an assumption failure is produced utilizing only the framework diagnostic generated by the <code>constraint</code>.</p> <p><code>assumeThat(assumable,actual,constraint,diagnostic)</code> also displays the diagnostic information in <code>diagnostic</code> upon a failure.</p> <p>When using this signature, both the diagnostic information contained within <code>diagnostic</code> is used in addition to the diagnostic information provided by the <code>constraint</code>.</p>
<b>Input Arguments</b>	<p><b>assumable</b></p> <p>The <code>matlab.unittest.TestCase</code> instance which is used to pass or fail the assumption in conjunction with the test running framework.</p> <p><b>actual</b></p> <p>The value to test.</p> <p><b>constraint</b></p> <p><b>diagnostic</b></p> <p>Diagnostic information to display upon a failure, specified as one of the following:</p> <ul style="list-style-type: none"><li>• string</li><li>• function handle</li><li>• <code>matlab.unittest.diagnostics.Diagnostic</code> object</li></ul>

# matlab.unittest.qualifications.Assumable.assumeThat

---

Diagnostic values can be nonscalar. For more information, see `matlab.unittest.diagnostics.Diagnostic`.

## **Examples**

See examples for `verifyThat`.

# matlab.unittest.qualifications.Assumable.assumeTrue

## Purpose

Assume value is true

## Syntax

```
assumeTrue(assumable,actual)
assumeTrue(assumable,actual,diagnostic)
```

## Description

`assumeTrue(assumable,actual)` assumes that `actual` is a scalar logical with the value of true.

`assumeTrue(assumable,actual,diagnostic)` also displays the diagnostic information in `diagnostic` upon a failure.

## Tips

- This method passes if and only if the actual value is a scalar logical with a value of true. Therefore, entities such as true valued arrays and nonzero doubles produce qualification failures when used in this method, despite these entities exhibiting "true-like" behavior such as triggering the execution of code inside of "if" statements.
- This method is functionally equivalent to:

```
import matlab.unittest.constraints.IsTrue;
assumable.assumeThat(actual, IsTrue());
```

There exists more functionality when using the `IsTrue` constraint directly via `assumeThat`.

Use of this method for performance benefits can come at the expense of less diagnostic information, and may not provide the same level of strictness adhered to by other constraints such as `IsEqualTo`. A similar approach that is generally less performant but can provide slightly better diagnostic information is the use of `assumeReturnsTrue`, which at least shows the display of the function evaluated to generate the failing result.

## Input Arguments

### **assumable**

The `matlab.unittest.TestCase` instance which is used to pass or fail the assumption in conjunction with the test running framework.

# matlab.unittest.qualifications.Assumable.assumeTrue

---

## **actual**

The value to test.

## **diagnostic**

Diagnostic information to display upon a failure, specified as one of the following:

- string
- function handle
- matlab.unittest.diagnostics.Diagnostic object

Diagnostic values can be nonscalar. For more information, see `matlab.unittest.diagnostics.Diagnostic`.

## **Examples**

See examples for `verifyTrue`.

## **See Also**

`assumeThat` | `assumeFalse` | `assumeReturnsTrue`

# matlab.unittest.qualifications.Assumable.assumeWarning

## Purpose

Assume function issues specified warning

## Syntax

```
assumeWarning(assumable,actual,warningID)
assumeWarning(assumable,actual,warningID,diagnostic)
[output1,...,outputN] = assumeWarning(___)
```

## Description

`assumeWarning(assumable,actual,warningID)` assumes that `actual` issues a warning with the identifier `warningID`.

`assumeWarning(assumable,actual,warningID,diagnostic)` also displays the diagnostic information in `diagnostic` upon a failure.

`[output1,...,outputN] = assumeWarning( ___ )` also return the output arguments `output1,...,outputN` that are produced when invoking `actual`.

## Tips

- This method is functionally equivalent to:

```
import matlab.unittest.constraints.IssuesWarnings;
assumable.assumeThat(actual, IssuesWarnings({warningID}));
```

There exists more functionality when using the `IssuesWarnings` constraint directly via `assumeThat`.

## Input Arguments

### **assumable**

The `matlab.unittest.TestCase` instance which is used to pass or fail the assumption in conjunction with the test running framework.

### **actual**

The function handle to test.

### **warningID**

Warning ID, specified as a string.

### **diagnostic**

# matlab.unittest.qualifications.Assumable.assumeWarning

---

Diagnostic information to display upon a failure, specified as one of the following:

- string
- function handle
- matlab.unittest.diagnostics.Diagnostic object

Diagnostic values can be nonscalar. For more information, see `matlab.unittest.diagnostics.Diagnostic`.

## Output Arguments

**output1,...,outputN**

Output arguments, 1 through n (if any), from `actual`, returned as any type. The argument type is specified by the `actual` argument list.

## Examples

See examples for `verifyWarning`.

## See Also

`assumeThat` | `assumeError` | `assumeWarningFree` | `warning`

# matlab.unittest.qualifications.Assumable.assumeWarning

## Purpose

Assume function issues no warnings

## Syntax

```
assumeWarningFree(assumable,actual)
assumeWarningFree(assumable,actual,diagnostic)
[output1,...,outputN] = assumeWarningFree(___)
```

## Description

`assumeWarningFree(assumable,actual)` assumes that `actual` is a function handle that issues no warnings.

`assumeWarningFree(assumable,actual,diagnostic)` also displays the diagnostic information in `diagnostic` upon a failure.

`[output1,...,outputN] = assumeWarningFree( ___ )` also returns the output arguments `output1,...,outputN` that are produced when invoking `actual`.

## Tips

- This method is functionally equivalent to:

```
import matlab.unittest.constraints.IssuesNoWarnings;
assumable.assumeThat(actual, IssuesNoWarnings());
```

There exists more functionality when using the `IssuesNoWarnings` constraint directly via `assumeThat`.

## Input Arguments

### **assumable**

The `matlab.unittest.TestCase` instance which is used to pass or fail the assumption in conjunction with the test running framework.

### **actual**

The function handle to test.

### **diagnostic**

Diagnostic information to display upon a failure, specified as one of the following:

- string

# matlab.unittest.qualifications.Assumable.assumeWarningFree

---

- function handle
- matlab.unittest.diagnostics.Diagnostic object

Diagnostic values can be nonscalar. For more information, see `matlab.unittest.diagnostics.Diagnostic`.

## Output Arguments

### **output1,...,outputN**

Output arguments, 1 through n (if any), from `actual`, returned as any type. The argument type is specified by the `actual` argument list.

## Examples

See examples for `verifyWarningFree`.

## See Also

`assumeThat` | `assumeWarning` | `warning`



# matlab.unittest.qualifications.AssumptionFailedException

---

**Purpose** Exception used for assumption failures

**Description** The AssumptionFailedException class provides an exception used for assumption failures. This class is used exclusively by the Assumable qualification type.

**See Also** Assumable | MException

# matlab.unittest.qualifications.ExceptionEventData

---

**Purpose** Event data for ExceptionThrown event listeners

**Description** The ExceptionEventData class holds event data for ExceptionThrown event listeners. ExceptionThrown event listeners are callback functions that you register with the testing framework to listen for the TestRunner to encounter an error during execution of test content. Typically, authors of custom plugins use this class. Only the test framework constructs this class directly.

**Properties** **Exception**  
Unexpected exception caught by TestRunner during its execution of test content

**See Also** [matlab.unittest.TestRunner](#) | [matlab.unittest.plugins.TestRunnerPlugin](#) | [MException](#)

**Concepts**

## Purpose

Qualification to abort test execution

## Description

The `FatalAssertable` class provides a qualification to abort test execution. Apart from actions performed for failures, the `FatalAssertable` class works the same as `matlab.unittest` qualifications.

Upon a fatal assertion failure, the `FatalAssertable` class informs the testing framework of the failure by throwing a `FatalAssertionFailedException`. The test running framework then displays diagnostic information for the failure and aborts the entire test session. This is useful when the software under test contains so many errors that it does not make sense to continue the test session. Also, you can use fatal assertions in fixture teardown to guarantee the fixture state is restored correctly. If it is not restored, the full testing session will aborts and indicates to restart MATLAB before you resume testing. This allows later tests to run in a consistent MATLAB state. If you can recover the fixture teardown and make it “Exception Safe” on page 1-5419 for failures, use assertions instead.

Fatal assertions prevent false test failures due to the failure of a fundamental test. They also prevent false test failures when a prior test failed to restore test fixtures. If the test framework cannot properly tear down fixtures, restart MATLAB to ensure testing can resume in a clean state.

## Methods

<code>fatalAssertClass</code>	Fatally assert exact class of specified value
<code>fatalAssertEmpty</code>	Fatally assert value is empty
<code>fatalAssertEqual</code>	Fatally assert value is equal to specified value
<code>fatalAssertError</code>	Fatally assert function throws specified exception

# matlab.unittest.qualifications.FatalAssertable

---

<code>fatalAssertFail</code>	Produce unconditional fatal assertion failure
<code>fatalAssertFalse</code>	Fatally assert value is false
<code>fatalAssertGreaterThanOrEqual</code>	Fatally assert value is greater than or equal to specified value
<code>fatalAssertInstanceOf</code>	Fatally assert value is object of specified type
<code>fatalAssertLength</code>	Fatally assert value has specified length
<code>fatalAssertLessThan</code>	Fatally assert value is less than specified value
<code>fatalAssertLessThanOrEqual</code>	Fatally assert value is less than or equal to specified value
<code>fatalAssertMatches</code>	Fatally assert string matches specified regular expression
<code>fatalAssertNotEmpty</code>	Fatally assert value is not empty
<code>fatalAssertNotEqual</code>	Fatally assert value is not equal to specified value
<code>fatalAssertNotSameHandle</code>	Fatally assert value is not handle to specified instance
<code>fatalAssertNumElements</code>	Fatally assert value has specified element count
<code>fatalAssertReturnsTrue</code>	Fatally assert function returns true when evaluated
<code>fatalAssertSameHandle</code>	Fatally assert two values are handles to same instance
<code>fatalAssertSize</code>	Fatally assert value has specified size
<code>fatalAssertSubstring</code>	Fatally assert string contains specified string

<code>fatalAssertThat</code>	Fatally assert value meets specified constraint
<code>fatalAssertTrue</code>	Fatally assert value is true
<code>fatalAssertWarning</code>	Fatally assert function issues specified warning
<code>fatalAssertWarningFree</code>	Fatally assert function issues no warnings

## Events

<code>FatalAssertionFailed</code>	Triggered upon failing fatal assertion. A <code>QualificationEventData</code> object is passed to listener callback functions.
<code>FatalAssertionPassed</code>	Triggered upon passing fatal assertion. A <code>QualificationEventData</code> object is passed to listener callback functions.

## Definitions

### Exception Safe

Test content is *exception safe* when all fixture teardown is performed with `addTeardown` or through the appropriate object destructors when a failure occurs. This ensures that the failure does not affect later testing due to stale fixtures.

This code is not exception safe. After an assertion failure, the test framework does not close the figure.

```
% Not exception safe
f = figure;
testCase.fatalAssertEqual(actual, expected);
close(f);
```

# matlab.unittest.qualifications.FatalAssertable

---

This code is exception safe because the test framework closes the figure in all cases.

```
% Exception safe
f = figure;
testCase.addTeardown(@close, f);
testCase.fatalAssertEqual(actual, expected);
```

However, tearing down a fixture using `addTeardown` does not guarantee code is exception safe. This code shows a failure in `fatalAssertEqual`.

```
% Not exception safe
f = figure;
testCase.fatalAssertEqual(actual, expected);
testCase.addTeardown(@close, f);
```

## Copy Semantics

Handle. To learn how handle classes affect copy operations, see Copying Objects in the MATLAB documentation.

## Examples

### Write Helper Function Using Fatal Assertions

A fatal assertion renders the remainder of the current test method invalid because the state is unrecoverable. A *helper function* is a function in the `TestCase` class but not located within any of the methods block statement. Execution of these functions is not controlled by the `matlab.unittest` framework.

Add the `DocPolynomSaveLoadTest.m` file to a folder on your MATLAB path. Refer to the helper function, `cleanupTemporaryFolder`, in the `DocPolynomSaveLoadTest` test case.

### DocPolynomSaveLoadTest Class Definition File

```
classdef DocPolynomSaveLoadTest < matlab.unittest.TestCase

 methods (TestClassSetup)
 function addDocPolynomClassToPath(testCase)
 origPath = path;
```

# matlab.unittest.qualifications.FatalAssertable

---

```
 testCase.addTeardown(@path, origPath);
 addpath(fullfile(matlabroot, ...
 'help', 'techdoc', 'matlab_oop', 'examples'));
 end
end

methods (Test)
 function testSaveLoad(testCase)

 import matlab.unittest.diagnostics.Diagnostic;

 %% Phase 1: Setup
 % Create a temporary working folder
 tempFolder = tempname;
 [success, message] = mkdir(tempFolder);
 testCase.assertTrue(success, ...
 Diagnostic.join('Could not create temporary folder.',
 message));
 testCase.addTeardown(@() testCase.cleanupTemporaryFolder(
 tempFolder));

 % Change to the temporary folder and register the
 % teardown, which restores the original folder
 origFolder = pwd;
 testCase.addTeardown(@cd, origFolder);
 cd(tempFolder);

 %% Phase 2: Exercise
 % Save the instance to a mat file.
 p = DocPolynom([1, 0, 1]);
 save('DocPolynomFile', 'p');

 % Validate Precondition. Save resulted in valid .mat file
 testCase.assertEqual(exist('DocPolynomFile.mat', 'file'),
 2, Diagnostic.join(...
 'mat file was not saved correctly.', @() dir(pwd)));
 end
end
```

# matlab.unittest.qualifications.FatalAssertable

---

```
loaded = load('DocPolynomFile');

%% Phase 3: Verify
testCase.verifyEqual(loaded.p, p,...
 'Loaded polynom did not equal original polynom.');
```

%% Phase 4: Teardown  
% Done inline via calls to addTeardown at the points  
% at which the state was changed.

```
end
end

methods(Access=private)
function cleanUpTemporaryFolder(testCase,tempFolder)
 % Clean up the temporary folder and fatally assert
 % that it was correctly cleaned up.

 import matlab.unittest.diagnostics.Diagnostic;

 [success, message] = rmdir(tempFolder, 's');
 testCase.fatalAssertTrue(success, ...
 Diagnostic.join('Could not remove temporary folder.',...
 message));
end
end
```

end

Make the `cleanUpTemporaryFolder` function a helper function by placing it inside a separate `methods` block.

```
methods(Access=private)
function cleanUpTemporaryFolder(testCase, tempFolder)
```



```
 % code
 end
end
```

Use the `fatalAssertTrue` method to test the `rmdir` `SUCCESS` argument for errors. If a fatal assertion occurs, the test run is aborted.

```
function cleanUpTemporaryFolder(testCase, tempFolder)

 import matlab.unittest.diagnostics.Diagnostic;

 [success, message] = rmdir(tempFolder, 's');
 testCase.fatalAssertTrue(success, ...
 Diagnostic.join('Could not remove the temporary folder.',...
 message));
end
```

If the `rmdir` function fails, then this test has failed to restore the state of MATLAB and the machine at initial startup. Aborting prevents subsequent tests to fail because MATLAB is left in an unexpected state by this test.

## See Also

[TestCase](#) | [Verifiable](#) | [Assumable](#) | [Assertable](#) |  
[matlab.unittest.qualifications](#) | [QualificationEventData](#)

## Concepts

# matlab.unittest.qualifications.FatalAssertable.fatalAssertClass

**Purpose**                      Fataally assert exact class of specified value

**Syntax**

```
fatalAssertClass(fatalAssertable,actual,className)
fatalAssertClass(fatalAssertable,actual,metaClass)
fatalAssertClass(___,diagnostic)
```

**Description**                `fatalAssertClass(fatalAssertable,actual,className)` fataally asserts that `actual` is a MATLAB value whose class is the class specified by `className`.

`fatalAssertClass(fatalAssertable,actual,metaClass)` fataally asserts that `actual` is a MATLAB value whose class is the class specified by the `meta.class` instance `metaClass`.

`fatalAssertClass(___,diagnostic)` also displays the diagnostic information in `diagnostic` upon a failure.

**Tips**

- The method is functionally equivalent to:

```
import matlab.unittest.constraints.IsOfClass;
fatalAssertable.fatalAssertThat(actual, IsOfClass(className));
fatalAssertable.fatalAssertThat(actual, IsOfClass(metaClass));
```

There exists more functionality when using the `IsOfClass` constraint directly via `fatalAssertThat`.

## Input Arguments

### **fatalAssertable**

The `matlab.unittest.TestCase` instance which is used to pass or fail the fatal assertion in conjunction with the test running framework.

### **actual**

The value to test.

### **className**

Name of class, specified as a string.

### **metaClass**

An instance of `meta.class`.

## **diagnostic**

Diagnostic information to display upon a failure, specified as one of the following:

- string
- function handle
- `matlab.unittest.diagnostics.Diagnostic` object

Diagnostic values can be nonscalar. For more information, see `matlab.unittest.diagnostics.Diagnostic`.

## **Examples**

See examples for `verifyClass`.

## **See Also**

`fatalAssertThat` | `fatalAssertInstanceOf`

# matlab.unittest.qualifications.FatalAssertable.fatalAssertEmpty

## Purpose

Fatally assert value is empty

## Syntax

```
fatalAssertEmpty(fatalAssertable,actual)
fatalAssertEmpty(fatalAssertable,actual,diagnostic)
```

## Description

`fatalAssertEmpty(fatalAssertable,actual)` fatally asserts that `actual` is an empty MATLAB value.

`fatalAssertEmpty(fatalAssertable,actual,diagnostic)` also displays the diagnostic information in `diagnostic` upon a failure.

## Tips

- This method is functionally equivalent to:

```
import matlab.unittest.constraints.IsEmpty;
fatalAssertable.fatalAssertThat(actual, IsEmpty());
```

There exists more functionality when using the `IsEmpty` constraint directly via `fatalAssertThat`.

## Input Arguments

### **fatalAssertable**

The `matlab.unittest.TestCase` instance which is used to pass or fail the fatal assertion in conjunction with the test running framework.

### **actual**

The value to test.

### **diagnostic**

Diagnostic information to display upon a failure, specified as one of the following:

- string
- function handle
- `matlab.unittest.diagnostics.Diagnostic` object

Diagnostic values can be nonscalar. For more information, see `matlab.unittest.diagnostics.Diagnostic`.

**Examples** See examples for `verifyEmpty`.

**See Also** `fatalAssertThat` | `fatalAssertNotEmpty` | `isempty`

# matlab.unittest.qualifications.FatalAssertable.fatalAssertEqual

## Purpose

Fatally assert value is equal to specified value

## Syntax

```
fatalAssertEqual(fatalAssertable,actual,expected)
fatalAssertEqual(__,Name,Value)
fatalAssertEqual(__,diagnostic)
```

## Description

`fatalAssertEqual(fatalAssertable,actual,expected)` fatally asserts that `actual` is strictly equal to `expected`.

`fatalAssertEqual(__,Name,Value)` fatally asserts equality with additional options specified by one or more `Name,Value` pair arguments.

`fatalAssertEqual(__,diagnostic)` also displays the diagnostic information in `diagnostic` upon a failure.

## Tips

- This method is functionally equivalent to any of the following:

```
import matlab.unittest.constraints.IsEqualTo;
fatalAssertable.fatalAssertThat(actual, IsEqualTo(expected));
```

```
import matlab.unittest.constraints.IsEqualTo;
import matlab.unittest.constraints.AbsoluteTolerance;
fatalAssertable.fatalAssertThat(actual, IsEqualTo(expected, ...
 'Within', AbsoluteTolerance(abstol)));
```

```
import matlab.unittest.constraints.IsEqualTo;
import matlab.unittest.constraints.RelativeTolerance;
fatalAssertable.fatalAssertThat(actual, IsEqualTo(expected, ...
 'Within', RelativeTolerance(reltol)));
```

```
import matlab.unittest.constraints.IsEqualTo;
import matlab.unittest.constraints.AbsoluteTolerance;
import matlab.unittest.constraints.RelativeTolerance;
fatalAssertable.fatalAssertThat(actual, IsEqualTo(expected, ...
 'Within', AbsoluteTolerance(abstol) | RelativeTolerance(reltol)));
```

There exists more functionality when using the `IsEqualTo`, `RelativeTolerance`, and `IsEqualTo` constraints directly via `fatalAssertThat`.

## Input Arguments

### **fatalAssertable**

The `matlab.unittest.TestCase` instance which is used to pass or fail the fatal assertion in conjunction with the test running framework.

### **actual**

The value to test.

### **expected**

Expected value.

### **diagnostic**

Diagnostic information to display upon a failure, specified as one of the following:

- string
- function handle
- `matlab.unittest.diagnostics.Diagnostic` object

Diagnostic values can be nonscalar. For more information, see `matlab.unittest.diagnostics.Diagnostic`.

## **Name-Value Pair Arguments**

Specify optional comma-separated pairs of `Name,Value` arguments. `Name` is the argument name and `Value` is the corresponding value. `Name` must appear inside single quotes ( ' '). You can specify several name and value pair arguments in any order as `Name1,Value1,...,NameN,ValueN`.

**'AbsTol'**

**'RelTol'**

# matlab.unittest.qualifications.FatalAssertable.fatalAssertEqual

---

**Examples**      See examples for `verifyEqual`.

**See Also**      `fatalAssertThat` | `fatalAssertNotEqual`



# matlab.unittest.qualifications.FatalAssertable.fatalAssertE

## Purpose

Fatally assert function throws specified exception

## Syntax

```
fatalAssertError(fatalAssertable,actual,identifier)
fatalAssertError(fatalAssertable,actual,metaClass)
fatalAssertError(___,diagnostic)
```

## Description

`fatalAssertError(fatalAssertable,actual,identifier)` fatally asserts that `actual` is a function handle that throws an exception with an error identifier that is equal to `identifier`.

`fatalAssertError(fatalAssertable,actual,metaClass)` fatally asserts that `actual` is a function handle that throws an exception whose type is defined by the `metaClass` instance specified in `metaClass`. This method does not require the instance to be an exact class match, but rather it must be in the specified class hierarchy, and that hierarchy must include the `MException` class..

`fatalAssertError(___,diagnostic)` also displays the diagnostic information in `diagnostic` upon a failure.

## Tips

- This method is functionally equivalent to:

```
import matlab.unittest.constraints.Throws;
fatalAssertable.fatalAssertThat(actual, Throws(identifier));
fatalAssertable.fatalAssertThat(actual, Throws(metaClass));
```

There exists more functionality when using the `Throws` constraint directly via `fatalAssertThat`.

## Input Arguments

### **fatalAssertable**

The `matlab.unittest.TestCase` instance which is used to pass or fail the fatal assertion in conjunction with the test running framework.

### **identifier**

Error identifier, specified as a string.

### **metaClass**

# matlab.unittest.qualifications.FatalAssertable.fatalAssertError

---

An instance of `meta.class`.

## **diagnostic**

Diagnostic information to display upon a failure, specified as one of the following:

- string
- function handle
- `matlab.unittest.diagnostics.Diagnostic` object

Diagnostic values can be nonscalar. For more information, see `matlab.unittest.diagnostics.Diagnostic`.

## **Examples**

See examples for `verifyError`.

## **See Also**

`fatalAssertThat` | `fatalAssertWarning` | `MException` | `error`

# matlab.unittest.qualifications.FatalAssertable.fatalAssertFail

---

## Purpose

Produce unconditional fatal assertion failure

## Syntax

```
fatalAssertFail(fatalAssertable)
fatalAssertFail(fatalAssertable,diagnostic)
```

## Description

`fatalAssertFail(fatalAssertable)` produces an unconditional fatal assertion failure when encountered.

`fatalAssertFail(fatalAssertable,diagnostic)` also displays the diagnostic information in `diagnostic` upon a failure.

## Input Arguments

### **fatalAssertable**

The `matlab.unittest.TestCase` instance which is used to pass or fail the fatal assertion in conjunction with the test running framework.

### **actual**

The value to test.

### **diagnostic**

Diagnostic information to display upon a failure, specified as one of the following:

- string
- function handle
- `matlab.unittest.diagnostics.Diagnostic` object

Diagnostic values can be nonscalar. For more information, see `matlab.unittest.diagnostics.Diagnostic`.

## Examples

See examples for `verifyFail`.

# matlab.unittest.qualifications.FatalAssertable.fatalAssertFalse

## Purpose

Fatally assert value is false

## Syntax

```
fatalAssertFalse(fatalAssertable,actual)
fatalAssertFalse(fatalAssertable,actual,diagnostic)
```

## Description

`fatalAssertFalse(fatalAssertable,actual)` fatally asserts that `actual` is a scalar logical with the value of false.

`fatalAssertFalse(fatalAssertable,actual,diagnostic)` also displays the diagnostic information in `diagnostic` upon a failure.

## Tips

- This method passes if and only if the actual value is a scalar logical with a value of false. Therefore, entities such as empty arrays, false valued arrays, and zero doubles produce failures when used in this method, despite these entities exhibiting "false-like" behavior such as bypassing the execution of code inside of "if" statements.
- This method is functionally equivalent to:

```
import matlab.unittest.constraints.IsFalse;
fatalAssertable.fatalAssertThat(actual, IsFalse());
```

There exists more functionality when using the `IsFalse` constraint directly via `fatalAssertThat`.

- Unlike `fatalAssertTrue`, this method may create a new constraint for each call. For performance critical uses, consider using `fatalAssertTrue`.

## Input Arguments

### **fatalAssertable**

The `matlab.unittest.TestCase` instance which is used to pass or fail the fatal assertion in conjunction with the test running framework.

### **actual**

The value to test.

### **diagnostic**

Diagnostic information to display upon a failure, specified as one of the following:

- string
- function handle
- `matlab.unittest.diagnostics.Diagnostic` object

Diagnostic values can be nonscalar. For more information, see `matlab.unittest.diagnostics.Diagnostic`.

## Examples

See examples for `verifyFalse`.

## See Also

`fatalAssertThat` | `fatalAssertTrue`

# matlab.unittest.qualifications.FatalAssertable.fatalAssertGreater

<b>Purpose</b>	Fatally assert value is greater than specified value
<b>Syntax</b>	<pre>fatalAssertGreaterThan(fatalAssertable,actual,floor) fatalAssertGreaterThan(fatalAssertable,actual,floor,diagnostic)</pre>
<b>Description</b>	<p><code>fatalAssertGreaterThan(fatalAssertable,actual,floor)</code> fatally asserts that all elements of <code>actual</code> are greater than all the elements of <code>floor</code>.</p> <p><code>fatalAssertGreaterThan(fatalAssertable,actual,floor,diagnostic)</code> also displays the diagnostic information in <code>diagnostic</code> upon a failure.</p>
<b>Tips</b>	<ul style="list-style-type: none"><li>This method is functionally equivalent to: <pre>matlab.unittest.constraints.IsGreaterThan; fatalAssertable.fatalAssertThat(actual, IsGreaterThan(floor));</pre><p>There exists more functionality when using the <code>IsGreaterThan</code> constraint directly via <code>fatalAssertThat</code>.</p></li></ul>
<b>Input Arguments</b>	<p><b>fatalAssertable</b></p> <p>The <code>matlab.unittest.TestCase</code> instance which is used to pass or fail the fatal assertion in conjunction with the test running framework.</p> <p><b>actual</b></p> <p>The value to test. <code>actual</code> must be the same size as <code>floor</code> unless either one is scalar, at which point scalar expansion occurs.</p> <p><b>floor</b></p> <p>Minimum value, exclusive.</p> <p><b>diagnostic</b></p> <p>Diagnostic information to display upon a failure, specified as one of the following:</p> <ul style="list-style-type: none"><li>string</li></ul>

- function handle
- matlab.unittest.diagnostics.Diagnostic object

Diagnostic values can be nonscalar. For more information, see `matlab.unittest.diagnostics.Diagnostic`.

## Examples

See examples for `verifyGreaterThan`.

## See Also

`fatalAssertThat` | `fatalAssertGreaterThanOrEqual` |  
`fatalAssertLessThan` | `fatalAssertLessThanOrEqual`  
| `gt` | `matlab.unittest.constraints.IsGreaterThan` |  
`matlab.unittest.diagnostics.Diagnostic`

# matlab.unittest.qualifications.FatalAssertable.fatalAssertGreater

## Purpose

Fatally assert value is greater than or equal to specified value

## Syntax

```
fatalAssertGreaterThanOrEqualTo(fatalAssertable,actual,floor)
fatalAssertGreaterThanOrEqualTo(fatalAssertable,actual,floor,
 diagnostic)
```

## Description

`fatalAssertGreaterThanOrEqualTo(fatalAssertable,actual,floor)` fatally asserts that all elements of `actual` are greater than or equal to all the elements of `floor`.

`fatalAssertGreaterThanOrEqualTo(fatalAssertable,actual,floor,diagnostic)` also displays the diagnostic information in `diagnostic` upon a failure.

## Tips

- This method is functionally equivalent to:

```
import matlab.unittest.constraints.IsGreaterThanOrEqualTo;
fatalAssertable.fatalAssertThat(actual, IsGreaterThanOrEqualTo(floor));
```

There exists more functionality when using the `IsGreaterThanOrEqualTo` constraint directly via `fatalAssertThat`.

## Input Arguments

### **fatalAssertable**

The `matlab.unittest.TestCase` instance which is used to pass or fail the fatal assertion in conjunction with the test running framework.

### **actual**

The value to test. `actual` must be the same size as `floor` unless either one is scalar, at which point scalar expansion occurs.

### **floor**

Minimum value.

### **diagnostic**

Diagnostic information to display upon a failure, specified as one of the following:



- string
- function handle
- matlab.unittest.diagnostics.Diagnostic object

Diagnostic values can be nonscalar. For more information, see `matlab.unittest.diagnostics.Diagnostic`.

## Examples

See examples for `verifyGreaterThanOrEqualTo`.

## See Also

`fatalAssertThat` | `fatalAssertGreaterThan` |  
`fatalAssertLessThanOrEqualTo` | `fatalAssertLessThan` | `ge` |  
`matlab.unittest.constraints.IsGreaterThanOrEqualTo` |  
`matlab.unittest.diagnostics.Diagnostic`

# matlab.unittest.qualifications.FatalAssertable.fatalAssertInstance

## Purpose

Fatally assert value is object of specified type

## Syntax

```
fatalAssertInstanceOf(fatalAssertable,actual,className)
fatalAssertInstanceOf(fatalAssertable,actual,metaClass)
fatalAssertInstanceOf(___,diagnostic)
```

## Description

`fatalAssertInstanceOf(fatalAssertable,actual,className)` fatally asserts that `actual` is a MATLAB value whose class is the class specified by `className`.

`fatalAssertInstanceOf(fatalAssertable,actual,metaClass)` `actual` is a MATLAB value whose class is the class specified by the `meta.class` instance `metaClass`.

`fatalAssertInstanceOf(___,diagnostic)` also displays the diagnostic information in `diagnostic` upon a failure.

## Tips

- This method is functionally equivalent to:

```
import matlab.unittest.constraints.IsInstanceOf;
fatalAssertable.fatalAssertThat(actual, IsInstanceOf(className));
fatalAssertable.fatalAssertThat(actual, IsInstanceOf(metaClass));
```

There exists more functionality when using the `IsInstanceOf` constraint directly via `fatalAssertThat`.

## Input Arguments

### **fatalAssertable**

The `matlab.unittest.TestCase` instance which is used to pass or fail the fatal assertion in conjunction with the test running framework.

### **actual**

The value to test.

### **className**

Name of class, specified as a string.

### **metaClass**

An instance of `meta.class`.

## **diagnostic**

Diagnostic information to display upon a failure, specified as one of the following:

- string
- function handle
- `matlab.unittest.diagnostics.Diagnostic` object

Diagnostic values can be nonscalar. For more information, see `matlab.unittest.diagnostics.Diagnostic`.

## **Examples**

See examples for `verifyInstanceOf`.

## **See Also**

`fatalAssertThat` | `fatalAssertClass` | `isa`

# matlab.unittest.qualifications.FatalAssertable.fatalAssertLength

<b>Purpose</b>	Fatally assert value has specified length
<b>Syntax</b>	<pre>fatalAssertLength(fatalAssertable,actual,expectedLength) fatalAssertLength(fatalAssertable,actual,expectedLength,diagnostic)</pre>
<b>Description</b>	<p><code>fatalAssertLength(fatalAssertable,actual,expectedLength)</code> fatally asserts that <code>actual</code> is a MATLAB array whose length is <code>expectedLength</code>.</p> <p><code>fatalAssertLength(fatalAssertable,actual,expectedLength,diagnostic)</code> also displays the diagnostic information in <code>diagnostic</code> upon a failure.</p>
<b>Tips</b>	<ul style="list-style-type: none"><li>This method is functionally equivalent to: <pre>import matlab.unittest.constraints.HasLength; fatalAssertable.fatalAssertThat(actual, HasLength(expectedLength));</pre><p>There exists more functionality when using the <code>HasLength</code> constraint directly via <code>fatalAssertThat</code>.</p></li></ul>
<b>Input Arguments</b>	<p><b>fatalAssertable</b></p> <p>The <code>matlab.unittest.TestCase</code> instance which is used to pass or fail the fatal assertion in conjunction with the test running framework.</p> <p><b>actual</b></p> <p>The value to test.</p> <p><b>expectedLength</b></p> <p>The length of an array is defined as the largest dimension of that array.</p> <p><b>diagnostic</b></p> <p>Diagnostic information to display upon a failure, specified as one of the following:</p> <ul style="list-style-type: none"><li>string</li></ul>

- function handle
- matlab.unittest.diagnostics.Diagnostic object

Diagnostic values can be nonscalar. For more information, see `matlab.unittest.diagnostics.Diagnostic`.

## Examples

See examples for `verifyLength`.

## See Also

`fatalAssertThat` | `fatalAssertSize` | `fatalAssertNumElements` | `length`

# matlab.unittest.qualifications.FatalAssertable.fatalAssertLessThan

## Purpose

Fatally assert value is less than specified value

## Syntax

```
fatalAssertLessThan(fatalAssertable,actual,ceiling)
fatalAssertLessThan(fatalAssertable,actual,ceiling,diagnostic)
```

## Description

`fatalAssertLessThan(fatalAssertable,actual,ceiling)` fatally asserts that all elements of `actual` are less than all the elements of `ceiling`.

`fatalAssertLessThan(fatalAssertable,actual,ceiling,diagnostic)` also displays the diagnostic information in `diagnostic` upon a failure.

## Tips

- This method is functionally equivalent to:

```
import matlab.unittest.constraints.IsLessThan;
assertable.assertThat(actual, IsLessThan(ceiling));
```

There exists more functionality when using the `IsLessThan` constraint directly via `assertThat`.

## Input Arguments

### **fatalAssertable**

The `matlab.unittest.TestCase` instance which is used to pass or fail the fatal assertion in conjunction with the test running framework.

### **actual**

The value to test. `actual` must be the same size as `ceiling` unless either one is scalar, at which point scalar expansion occurs.

### **ceiling**

Maximum value, exclusive.

### **diagnostic**

Diagnostic information to display upon a failure, specified as one of the following:

- string

- function handle
- matlab.unittest.diagnostics.Diagnostic object

Diagnostic values can be nonscalar. For more information, see `matlab.unittest.diagnostics.Diagnostic`.

## Examples

See examples for `verifyLessThan`.

## See Also

`fatalAssertThat` | `fatalAssertLessThanOrEqual` |  
`fatalAssertGreaterThan` | `fatalAssertGreaterThanOrEqual`  
| `lt` | `matlab.unittest.constraints.IsLessThan` |  
`matlab.unittest.diagnostics.Diagnostic`

# matlab.unittest.qualifications.FatalAssertable.fatalAssertLessThanOrEqual

## Purpose

Fatally assert value is less than or equal to specified value

## Syntax

```
fatalAssertLessThanOrEqual(fatalAssertable,actual,ceiling)
fatalAssertLessThanOrEqual(fatalAssertable,actual,ceiling,diagnostic)
```

## Description

`fatalAssertLessThanOrEqual(fatalAssertable,actual,ceiling)` fatally asserts that all elements of `actual` are less than or equal to all the elements of `ceiling`.

`fatalAssertLessThanOrEqual(fatalAssertable,actual,ceiling,diagnostic)` also displays the diagnostic information in `diagnostic` upon a failure.

## Tips

- This method is functionally equivalent to:

```
import matlab.unittest.constraints.IsLessThanOrEqualTo;
fatalAssertable.fatalAssertThat(actual, IsLessThanOrEqualTo(ceiling));
```

There exists more functionality when using the `IsLessThanOrEqualTo` constraint directly via `fatalAssertThat`.

## Input Arguments

### **fatalAssertable**

The `matlab.unittest.TestCase` instance which is used to pass or fail the fatal assertion in conjunction with the test running framework.

### **actual**

The value to test. `actual` must be the same size as `ceiling` unless either one is scalar, at which point scalar expansion occurs.

### **actual**

The value to test.

### **ceiling**

Maximum value.

### **diagnostic**



Diagnostic information to display upon a failure, specified as one of the following:

- string
- function handle
- matlab.unittest.diagnostics.Diagnostic object

Diagnostic values can be nonscalar. For more information, see `matlab.unittest.diagnostics.Diagnostic`.

## Examples

See examples for `verifyLessThanOrEqual`.

## See Also

`fatalAssertThat` | `fatalAssertLessThan` |  
`fatalAssertGreaterThan` | `fatalAssertGreaterThanOrEqual`  
`| le` | `matlab.unittest.constraints.IsLessThanOrEqualTo` |  
`matlab.unittest.diagnostics.Diagnostic`

# matlab.unittest.qualifications.FatalAssertable.fatalAssertMatches

<b>Purpose</b>	Fatally assert string matches specified regular expression
<b>Syntax</b>	<code>fatalAssertMatches(fatalAssertable,actual,expression)</code> <code>fatalAssertMatches(fatalAssertable,actual,expression,diagnostic)</code>
<b>Description</b>	<code>fatalAssertMatches(fatalAssertable,actual,expression)</code> fatally asserts that <code>actual</code> is a string that matches the regular expression defined by <code>expression</code> . <code>fatalAssertMatches(fatalAssertable,actual,expression,diagnostic)</code> also displays the diagnostic information in <code>diagnostic</code> upon a failure.
<b>Tips</b>	<ul style="list-style-type: none"><li>This method is functionally equivalent to: <pre>import matlab.unittest.constraints.Matches; fatalAssertable.fatalAssertThat(actual, Matches(expression));</pre> There exists more functionality when using the <code>Matches</code> constraint directly via <code>fatalAssertThat</code>.</li></ul>
<b>Input Arguments</b>	<p><b>fatalAssertable</b></p> <p>The <code>matlab.unittest.TestCase</code> instance which is used to pass or fail the fatal assertion in conjunction with the test running framework.</p> <p><b>actual</b></p> <p>The value to test.</p> <p><b>expression</b></p> <p>The value to match, specified as a regular expression.</p> <p><b>diagnostic</b></p> <p>Diagnostic information to display upon a failure, specified as one of the following:</p> <ul style="list-style-type: none"><li>string</li></ul>

- function handle
- matlab.unittest.diagnostics.Diagnostic object

Diagnostic values can be nonscalar. For more information, see `matlab.unittest.diagnostics.Diagnostic`.

## Examples

See examples for `verifyMatches`.

## See Also

`fatalAssertThat` | `fatalAssertSubstring` | `regexp`

<b>Purpose</b>	Fatally assert value is not empty
<b>Syntax</b>	<pre>fatalAssertNotEmpty(fatalAssertable,actual) fatalAssertNotEmpty(fatalAssertable,actual,diagnostic)</pre>
<b>Description</b>	<p><code>fatalAssertNotEmpty(fatalAssertable,actual)</code> fatally asserts that <code>actual</code> is a non-empty MATLAB value.</p> <p><code>fatalAssertNotEmpty(fatalAssertable,actual,diagnostic)</code> also displays the diagnostic information in <code>diagnostic</code> upon a failure.</p>
<b>Tips</b>	<ul style="list-style-type: none"><li>• This method is functionally equivalent to: <pre>import matlab.unittest.constraints.IsEmpty; fatalAssertable.fatalAssertThat(actual, ~IsEmpty());</pre><p>There exists more functionality when using the <code>IsEmpty</code> constraint directly via <code>fatalAssertThat</code>.</p></li></ul>
<b>Input Arguments</b>	<p><b>fatalAssertable</b></p> <p>The <code>matlab.unittest.TestCase</code> instance which is used to pass or fail the fatal assertion in conjunction with the test running framework.</p> <p><b>actual</b></p> <p>The value to test.</p> <p><b>diagnostic</b></p> <p>Diagnostic information to display upon a failure, specified as one of the following:</p> <ul style="list-style-type: none"><li>• string</li><li>• function handle</li><li>• <code>matlab.unittest.diagnostics.Diagnostic</code> object</li></ul>

Diagnostic values can be nonscalar. For more information, see `matlab.unittest.diagnostics.Diagnostic`.

**Examples** See examples for `verifyNotEmpty`.

**See Also** `fatalAssertThat` | `fatalAssertEmpty` | `isempty`

# matlab.unittest.qualifications.FatalAssertable.fatalAssertNotEqual

## Purpose

Fatally assert value is not equal to specified value

## Syntax

```
fatalAssertNotEqual(fatalAssertable, actual, notExpected)
fatalAssertNotEqual(fatalAssertable, actual, notExpected, diagnostic)
```

## Description

`fatalAssertNotEqual(fatalAssertable, actual, notExpected)` fatally asserts that `actual` is not equal to `notExpected`.

`fatalAssertNotEqual(fatalAssertable, actual, notExpected, diagnostic)` also displays the diagnostic information in `diagnostic` upon a failure.

## Tips

- This method is functionally equivalent to:

```
import matlab.unittest.constraints.IsEqualTo;
fatalAssertable.fatalAssertThat(actual, ~IsEqualTo(notExpected));
```

There exists more functionality when using the `IsEqualTo` constraint directly via `fatalAssertThat`.

## Input Arguments

### **fatalAssertable**

The `matlab.unittest.TestCase` instance which is used to pass or fail the fatal assertion in conjunction with the test running framework.

### **actual**

The value to test.

### **notExpected**

Value to compare.

## Examples

See examples for `verifyNotEqual`.

## See Also

`fatalAssertThat` | `fatalAssertEqual`

# matlab.unittest.qualifications.FatalAssertable.fatalAssertNotSameHandle

## Purpose

Fatally assert value is not handle to specified instance

## Syntax

```
fatalAssertNotSameHandle(fatalAssertable,actual,notExpectedHandle)
fatalAssertNotSameHandle(fatalAssertable,actual,notExpectedHandle,
 diagnostic)
```

## Description

`fatalAssertNotSameHandle(fatalAssertable,actual,notExpectedHandle)` fatally asserts that `actual` is a different size and/or does not contain the same instances as the `notExpectedHandle` handle array.

`fatalAssertNotSameHandle(fatalAssertable,actual,notExpectedHandle,diagnostic)` also displays the diagnostic information in `diagnostic` upon a failure.

## Tips

- This method is functionally equivalent to:

```
import matlab.unittest.constraints.IsSameHandleAs;
fatalAssertable.fatalAssertThat(actual, ~IsSameHandleAs(notExpectedHandleArray));
```

There exists more functionality when using the `IsSameHandleAs` constraint directly via `fatalAssertThat`.

## Input Arguments

### **fatalAssertable**

The `matlab.unittest.TestCase` instance which is used to pass or fail the fatal assertion in conjunction with the test running framework.

### **actual**

The value to test.

### **notExpectedHandle**

The handle array to compare.

### **diagnostic**

Diagnostic information to display upon a failure, specified as one of the following:

- string
- function handle
- matlab.unittest.diagnostics.Diagnostic object

Diagnostic values can be nonscalar. For more information, see `matlab.unittest.diagnostics.Diagnostic`.

## Examples

See examples for `verifyNotSameHandle`.

## See Also

`fatalAssertThat` | `fatalAssertSameHandle`



# matlab.unittest.qualifications.FatalAssertable.fatalAssertNumElements

## Purpose

Fatally assert value has specified element count

## Syntax

```
fatalAssertNumElements(fatalAssertable,actual,expectedElementCount)
fatalAssertNumElements(fatalAssertable,actual,expectedElementCount,
 diagnostic)
```

## Description

`fatalAssertNumElements(fatalAssertable,actual,expectedElementCount)` fatally asserts that `actual` is a MATLAB array with `expectedElementCount` number of elements.

`fatalAssertNumElements(fatalAssertable,actual,expectedElementCount,diagnostic)` also displays the diagnostic information in `diagnostic` upon a failure.

## Tips

- This method is functionally equivalent to:

```
import matlab.unittest.constraints.HasElementCount;
fatalAssertable.fatalAssertThat(actual, HasElementCount(expectedElementCount))
```

There exists more functionality when using the `HasElementCount` constraint directly via `fatalAssertThat`.

## Input Arguments

### **fatalAssertable**

The `matlab.unittest.TestCase` instance which is used to pass or fail the fatal assertion in conjunction with the test running framework.

### **actual**

The value to test.

### **expectedElementCount**

The expected number of elements in the array.

### **diagnostic**

Diagnostic information to display upon a failure, specified as one of the following:

- string
- function handle
- matlab.unittest.diagnostics.Diagnostic object

Diagnostic values can be nonscalar. For more information, see `matlab.unittest.diagnostics.Diagnostic`.

## Examples

See examples for `verifyNumElements`.

## See Also

`fatalAssertThat` | `fatalAssertSize` | `fatalAssertLength` | `numel`

## Purpose

Fatally assert function returns true when evaluated

## Syntax

```
fatalAssertReturnsTrue(fatalAssertable, actual)
fatalAssertReturnsTrue(fatalAssertable, actual, diagnostic)
```

## Description

`fatalAssertReturnsTrue(fatalAssertable, actual)` fatally asserts that `actual` is a function handle that returns a scalar logical whose value is true.

`fatalAssertReturnsTrue(fatalAssertable, actual, diagnostic)` also displays the diagnostic information in `diagnostic` upon a failure.

## Tips

- It is a shortcut for quick custom comparison functionality that can be defined quickly, and possibly inline. It can be preferable over simply evaluating the function directly and using `fatalAssertTrue` because the function handle will be shown in the diagnostics, thus providing more insight into the failure condition which is lost when using `fatalAssertTrue`.
- This method is functionally equivalent to:

```
import matlab.unittest.constraints.ReturnsTrue;
fatalAssertable.fatalAssertThat(actual, ReturnsTrue());
```

There exists more functionality when using the `ReturnsTrue` constraint directly via `fatalAssertThat`.

## Input Arguments

### **fatalAssertable**

The `matlab.unittest.TestCase` instance which is used to pass or fail the fatal assertion in conjunction with the test running framework.

### **actual**

The function handle to test.

### **diagnostic**

Diagnostic information to display upon a failure, specified as one of the following:

- string
- function handle
- `matlab.unittest.diagnostics.Diagnostic` object

Diagnostic values can be nonscalar. For more information, see `matlab.unittest.diagnostics.Diagnostic`.

## Examples

See examples for `verifyReturnsTrue`.

## See Also

`fatalAssertThat` | `fatalAssertTrue`

# matlab.unittest.qualifications.FatalAssertable.fatalAssertS

## Purpose

Fatally assert two values are handles to same instance

## Syntax

```
fatalAssertSameHandle(fatalAssertable,actual,expectedHandle)
fatalAssertSameHandle(fatalAssertable,actual,expectedHandle,
 diagnostic)
```

## Description

`fatalAssertSameHandle(fatalAssertable,actual,expectedHandle)` fatally asserts that `actual` is the same size and contains the same instances as the `expectedHandle` handle array.

`fatalAssertSameHandle(fatalAssertable,actual,expectedHandle,diagnostic)` also displays the diagnostic information in `diagnostic` upon a failure.

## Tips

- This method is functionally equivalent to:

```
import matlab.unittest.constraints.IsSameHandleAs;
fatalAssertable.fatalAssertThat(actual, IsSameHandleAs(expectedHandl
```

There exists more functionality when using the `IsSameHandleAs` constraint directly via `fatalAssertThat`.

## Input Arguments

### **fatalAssertable**

The `matlab.unittest.TestCase` instance which is used to pass or fail the fatal assertion in conjunction with the test running framework.

### **actual**

The value to test.

### **expectedHandle**

The expected handle array.

### **diagnostic**

Diagnostic information to display upon a failure, specified as one of the following:

# matlab.unittest.qualifications.FatalAssertable.fatalAssertSame

---

- string
- function handle
- matlab.unittest.diagnostics.Diagnostic object

Diagnostic values can be nonscalar. For more information, see `matlab.unittest.diagnostics.Diagnostic`.

## Examples

See examples for `verifySameHandle`.

## See Also

`fatalAssertThat` | `fatalAssertNotSameHandle` | `handle`

# matlab.unittest.qualifications.FatalAssertable.fatalAssertSize

## Purpose

Fatally assert value has specified size

## Syntax

```
fatalAssertSize(fatalAssertable,actual,expectedSize)
fatalAssertSize(fatalAssertable,actual,expectedSize,diagnostic)
```

## Description

`fatalAssertSize(fatalAssertable,actual,expectedSize)` fatally asserts that `actual` is a MATLAB array whose size is `expectedSize`.  
`fatalAssertSize(fatalAssertable,actual,expectedSize,diagnostic)` also displays the diagnostic information in `diagnostic` upon a failure.

## Tips

- This method is functionally equivalent to:

```
import matlab.unittest.constraints.HasSize;
fatalAssertable.fatalAssertThat(actual, HasSize(expectedSize));
```

There exists more functionality when using the `HasSize` constraint directly via `fatalAssertThat`.

## Input Arguments

### **fatalAssertable**

The `matlab.unittest.TestCase` instance which is used to pass or fail the fatal assertion in conjunction with the test running framework.

### **actual**

The value to test.

### **expectedSize**

The expected sizes of each dimension the array.

### **diagnostic**

Diagnostic information to display upon a failure, specified as one of the following:

- string
- function handle

# matlab.unittest.qualifications.FatalAssertable.fatalAssertSize

---

- `matlab.unittest.diagnostics.Diagnostic` object

Diagnostic values can be nonscalar. For more information, see `matlab.unittest.diagnostics.Diagnostic`.

## Examples

See examples for `verifySize`.

## See Also

`fatalAssertThat` | `fatalAssertLength` | `fatalAssertNumElements`  
| `size`



## Purpose

Fatally assert string contains specified string

## Syntax

```
fatalAssertSubstring(fatalAssertable,actual,substring)
fatalAssertSubstring(fatalAssertable,actual,substring,diagnostic)
```

## Description

`fatalAssertSubstring(fatalAssertable,actual,substring)` fatally asserts that `actual` is a string that contains `substring`.

`fatalAssertSubstring(fatalAssertable,actual,substring,diagnostic)` also displays the diagnostic information in `diagnostic` upon a failure.

## Tips

- This method is functionally equivalent to:

```
import matlab.unittest.constraints.ContainsSubstring;
fatalAssertable.fatalAssertThat(actual,...
 ContainsSubstring(substring));
```

There exists more functionality when using the `ContainsSubstring` constraint directly via `fatalAssertThat`.

## Input Arguments

### **fatalAssertable**

The `matlab.unittest.TestCase` instance which is used to pass or fail the fatal assertion in conjunction with the test running framework.

### **actual**

The value to test.

### **substring**

The value to match, specified as a string.

### **diagnostic**

Diagnostic information to display upon a failure, specified as one of the following:

- string

# matlab.unittest.qualifications.FatalAssertable.fatalAssertSubstr

---

- function handle
- matlab.unittest.diagnostics.Diagnostic object

Diagnostic values can be nonscalar. For more information, see `matlab.unittest.diagnostics.Diagnostic`.

## Examples

See examples for `verifySubstring`.

## See Also

`fatalAssertThat` | `fatalAssertMatches` | `strfind`

# matlab.unittest.qualifications.FatalAssertable.fatalAssertThat

---

## Purpose

Fatally assert value meets specified constraint

## Syntax

```
fatalAssertThat(fatalAssertable, actual, constraint)
fatalAssertThat(fatalAssertable, actual, constraint, diagnostic)
```

## Description

`fatalAssertThat(fatalAssertable, actual, constraint)` fatally asserts that `actual` is a value that satisfies the `constraint` provided.

If the constraint is not satisfied, a fatal assertion failure is produced utilizing only the framework diagnostic generated by the `constraint`.

`fatalAssertThat(fatalAssertable, actual, constraint, diagnostic)` also displays the diagnostic information in `diagnostic` upon a failure.

When using this signature, both the diagnostic information contained within `diagnostic` is used in addition to the diagnostic information provided by the `constraint`.

## Input Arguments

### **fatalAssertable**

The `matlab.unittest.TestCase` instance which is used to pass or fail the fatal assertion in conjunction with the test running framework.

### **actual**

The value to test.

### **constraint**

### **diagnostic**

Diagnostic information to display upon a failure, specified as one of the following:

- string
- function handle
- `matlab.unittest.diagnostics.Diagnostic` object

# matlab.unittest.qualifications.FatalAssertable.fatalAssertThat

---

Diagnostic values can be nonscalar. For more information, see `matlab.unittest.diagnostics.Diagnostic`.

## Examples

See examples for `verifyThat`.

# matlab.unittest.qualifications.FatalAssertable.fatalAssertT

---

## Purpose

Fatally assert value is true

## Syntax

```
fatalAssertTrue(fatalAssertable, actual)
fatalAssertTrue(fatalAssertable, actual, diagnostic)
```

## Description

`fatalAssertTrue(fatalAssertable, actual)` fatally asserts that `actual` is a scalar logical with the value of true.

`fatalAssertTrue(fatalAssertable, actual, diagnostic)` also displays the diagnostic information in `diagnostic` upon a failure.

## Tips

- This method passes if and only if the actual value is a scalar logical with a value of true. Therefore, entities such as true valued arrays and nonzero doubles produce qualification failures when used in this method, despite these entities exhibiting "true-like" behavior such as triggering the execution of code inside of "if" statements.
- This method is functionally equivalent to:

```
import matlab.unittest.constraints.IsTrue;
fatalAssertable.fatalAssertThat(actual, IsTrue());
```

There exists more functionality when using the `IsTrue` constraint directly via `fatalAssertThat`.

However, this method is optimized for performance and does not construct a new `IsTrue` constraint for each call. Sometimes such use can come at the expense of less diagnostic information. Use the `fatalAssertReturnsTrue` method for a similar approach which may provide better diagnostic information.

## Input Arguments

### **fatalAssertable**

The `matlab.unittest.TestCase` instance which is used to pass or fail the fatal assertion in conjunction with the test running framework.

### **actual**

# matlab.unittest.qualifications.FatalAssertable.fatalAssertTrue

---

The value to test.

## **diagnostic**

Diagnostic information to display upon a failure, specified as one of the following:

- string
- function handle
- matlab.unittest.diagnostics.Diagnostic object

Diagnostic values can be nonscalar. For more information, see `matlab.unittest.diagnostics.Diagnostic`.

## **Examples**

See examples for `verifyTrue`.

## **See Also**

`fatalAssertThat` | `fatalAssertFalse` | `fatalAssertReturnsTrue`

# matlab.unittest.qualifications.FatalAssertable.fatalAssertWarning

## Purpose

Fatally assert function issues specified warning

## Syntax

```
fatalAssertWarning(fatalAssertable,actual,warningID)
fatalAssertWarning(fatalAssertable,actual,warningID,diagnostic)
[output1,...,outputN] = fatalAssertWarning(___)
```

## Description

`fatalAssertWarning(fatalAssertable,actual,warningID)` fatally asserts that `actual` issues a warning with the identifier `warningID`.

`fatalAssertWarning(fatalAssertable,actual,warningID,diagnostic)` also displays the diagnostic information in `diagnostic` upon a failure.

`[output1,...,outputN] = fatalAssertWarning( ___ )` also returns the output arguments `output1,...,outputN` that are produced when invoking `actual`.

## Tips

- This method is functionally equivalent to:

```
import matlab.unittest.constraints.IssuesWarnings;
fatalAssertable.fatalAssertThat(actual, IssuesWarnings({warningID}))
```

There exists more functionality when using the `IssuesWarnings` constraint directly via `fatalAssertThat`.

## Input Arguments

### **fatalAssertable**

The `matlab.unittest.TestCase` instance which is used to pass or fail the fatal assertion in conjunction with the test running framework.

### **actual**

The function handle to test.

### **warningID**

Warning ID, specified as a string.

### **diagnostic**

Diagnostic information to display upon a failure, specified as one of the following:

- string
- function handle
- matlab.unittest.diagnostics.Diagnostic object

Diagnostic values can be nonscalar. For more information, see `matlab.unittest.diagnostics.Diagnostic`.

## Output Arguments

**output1,...,outputN**

Output arguments, 1 through n (if any), from `actual`, returned as any type. The argument type is specified by the `actual` argument list.

## Examples

See examples for `verifyWarning`.

## See Also

`fatalAssertThat` | `fatalAssertError` | `fatalAssertWarningFree` | `warning`



# matlab.unittest.qualifications.FatalAssertable.fatalAssertV

---

## Purpose

Fatally assert function issues no warnings

## Syntax

```
fatalAssertWarningFree(fatalAssertable,actual)
fatalAssertWarningFree(fatalAssertable,actual,diagnostic)
[output1,...,outputN] = fatalAssertWarningFree(___)
```

## Description

`fatalAssertWarningFree(fatalAssertable,actual)` fatally asserts that `actual` is a function handle that issues no warnings.

`fatalAssertWarningFree(fatalAssertable,actual,diagnostic)` also displays the diagnostic information in `diagnostic` upon a failure.

`[output1,...,outputN] = fatalAssertWarningFree( ___ )` also returns the output arguments `output1,...,outputN` that are produced when invoking `actual`.

## Tips

- This method is functionally equivalent to:

```
import matlab.unittest.constraints.IssuesNoWarnings;
fatalAssertable.fatalAssertThat(actual, IssuesNoWarnings());
```

There exists more functionality when using the `IssuesNoWarnings` constraint directly via `fatalAssertThat`.

## Input Arguments

### **fatalAssertable**

The `matlab.unittest.TestCase` instance which is used to pass or fail the fatal assertion in conjunction with the test running framework.

### **actual**

The function handle to test.

### **diagnostic**

Diagnostic information to display upon a failure, specified as one of the following:

- string

- function handle
- matlab.unittest.diagnostics.Diagnostic object

Diagnostic values can be nonscalar. For more information, see `matlab.unittest.diagnostics.Diagnostic`.

## Output Arguments

### **output1,...,outputN**

Output arguments, 1 through n (if any), from `actual`, returned as any type. The argument type is specified by the `actual` argument list.

## Examples

See examples for `verifyWarningFree`.

## See Also

`fatalAssertThat` | `fatalAssertWarning` | `warning`

# matlab.unittest.qualifications.FatalAssertionFailedException

---

**Purpose** Exception used for fatal assertion failures

**Description** The FatalAssertionFailedException class provides an exception used for fatal assertion failures. This class is used exclusively by the FatalAssertable qualification type.

**See Also** FatalAssertable | MException

# matlab.unittest.qualifications.QualificationEventData

---

## Purpose

Event data for qualification event listeners

## Description

The `QualificationEventData` class holds event data for qualification event listeners. Qualification event listeners are callback functions that you register with the testing framework to listen for passing and/or failing qualifications. Qualifications can be assertions, fatal assertions, assumptions or verifications performed on test content. The corresponding qualification classes define these events. Typically, authors of custom plugins use this class. Only the test framework constructs this class directly.

## Properties

### ActualValue

Value tested to satisfy the qualification logic of the Constraint

### Constraint

Instance of `matlab.unittest.constraints.Constraint` used for the qualification

When you use a qualification method on a `TestCase` or `Fixture` object, the `Constraint` property contains the underlying constraint used for the qualification. For example, if you use the `verifyEqual` method, the underlying constraint is the `IsEqualTo` constraint. Therefore, if you invoke the constraint's `getDiagnosticFor` method, the diagnostic result can appear different than what the test framework displays.

### TestDiagnostic

Diagnostic specified in the qualification, represented as a string, function handle, or instance of the `Diagnostic` class

### TestDiagnosticResult

Result of diagnostic specified in the qualification, represented as a character array

### FrameworkDiagnosticResult

Result of diagnostic from constraint used for the qualification, represented as a character array

## **Stack**

Function call stack leading up to the qualification event, represented as a structure array

## **See Also**

matlab.unittest.qualifications.Assertable |  
matlab.unittest.qualifications.Assumable |  
matlab.unittest.qualifications.FatalAssertable  
| matlab.unittest.qualifications.Verifiable |  
matlab.unittest.fixtures.Fixture

## **Concepts**

# matlab.unittest.qualifications.Verifiable

---

**Purpose** Qualification to produce soft-failure conditions

**Description** The `Verifiable` class provides a qualification to produce soft-failure conditions. Apart from actions performed for failures, the `Verifiable` class works the same as other `matlab.unittest` qualifications.

Upon a verification failure, the `Verifiable` class informs the testing framework of the failure, including all diagnostic information associated with the failure, but continues to execute the currently running test without throwing an `MException`. This is most useful when a failure at the verification point is not fatal to the remaining test content. Often, you use verifications as the primary verification of a Four-Phase Test. Use other qualification types, such as assertions, fatal assertions, and assumptions, to test for violation of preconditions or incorrect test setup.

Since verifications do not throw `MExceptions`, all test content runs to completion even when verification failures occur. This helps you understand how close a piece of software is to meeting the test suite requirements. Qualification types that throw exceptions do not provide this insight, since once an exception is thrown an arbitrary amount of code remains that is not reached or exercised. Verifications also provide more testing coverage in failure conditions. However, when you overuse verifications, they can produce excess noise for a single failure condition. If a failure condition will cause later qualification points to also fail, use assertions or fatal assertions instead.

## Methods

<code>verifyClass</code>	Verify exact class of specified value
<code>verifyEmpty</code>	Verify value is empty
<code>verifyEqual</code>	Verify value is equal to specified value
<code>verifyError</code>	Verify function throws specified exception

<code>verifyFail</code>	Produce unconditional verification failure
<code>verifyFalse</code>	Verify value is false
<code>verifyGreaterThan</code>	Verify value is greater than specified value
<code>verifyGreaterThanOrEqual</code>	Verify value is greater than or equal to specified value
<code>verifyInstanceOf</code>	Verify value is object of specified type
<code>verifyLength</code>	Verify value has specified length
<code>verifyLessThan</code>	Verify value is less than specified value
<code>verifyLessThanOrEqual</code>	Verify value is less than or equal to specified value
<code>verifyMatches</code>	Verify string matches specified regular expression
<code>verifyNotEmpty</code>	Verify value is not empty
<code>verifyNotEqual</code>	Verify value is not equal to specified value
<code>verifyNotSameHandle</code>	Verify value is not handle to specified instance
<code>verifyNumElements</code>	Verify value has specified element count
<code>verifyReturnsTrue</code>	Verify function returns true when evaluated
<code>verifySameHandle</code>	Verify two values are handles to same instance
<code>verifySize</code>	Verify value has specified size

# matlab.unittest.qualifications.Verifiable

---

<code>verifySubstring</code>	Verify string contains specified string
<code>verifyThat</code>	Verify value meets given constraint
<code>verifyTrue</code>	Verify value is true
<code>verifyWarning</code>	Verify function issues specified warning
<code>verifyWarningFree</code>	Verify function issues no warnings

## Events

<code>VerificationFailed</code>	Triggered upon failing verification. A <code>QualificationEventData</code> object is passed to listener callback functions.
<code>VerificationPassed</code>	Triggered upon passing verification. A <code>QualificationEventData</code> object is passed to listener callback functions.

## Copy Semantics

Handle. To learn how handle classes affect copy operations, see Copying Objects in the MATLAB documentation.

## Examples

### Write Test Methods Using Verifications

Verifications produce and record failures without throwing an exception, meaning the currently running test runs to completion. This example creates a test case to verify arithmetic operations on objects of the `DocPolynom` example class.



Create the DocPolynomTest Test Case. Refer to the following DocPolynomTest test case in the subsequent steps in this example, which highlight specific functions in the file.

## DocPolynomTest Class Definition File

```
classdef DocPolynomTest < matlab.unittest.TestCase
 % Tests the DocPolynom class.

 properties
 msgEqn = 'Equation under test: ';
 end

 methods (TestClassSetup)
 function addDocPolynomClassToPath(testCase)
 testCase.addTeardown(@path,addpath(fullfile(matlabroot,...
 'help', 'techdoc', 'matlab_oop', 'examples')));
 end
 end

 methods (Test)
 function testConstructor(testCase)
 p = DocPolynom([1, 0, 1]);
 testCase.verifyClass(p, ?DocPolynom);
 end

 function testAddition(testCase)
 p1 = DocPolynom([1, 0, 1]);
 p2 = DocPolynom([5, 2]);

 actual = p1 + p2;
 expected = DocPolynom([1, 5, 3]);

 msg = [testCase.msgEqn,...
 '(x^2 + 1) + (5*x + 2) = x^2 + 5*x + 3'];
 testCase.verifyEqual(actual, expected, msg);
 end
 end
end
```

# matlab.unittest.qualifications.Verifiable

---

```
function testMultiplication(testCase)
 p1 = DocPolynom([1, 0, 3]);
 p2 = DocPolynom([5, 2]);

 actual = p1 * p2;
 expected = DocPolynom([5, 2, 15, 6]);

 msg = [testCase.msgEqn,...
 '(x^2 + 3) * (5*x + 2) = 5*x^3 + 2*x^2 + 15*x + 6'];
 testCase.verifyEqual(actual, expected, msg);
end

end
end
```

To execute the MATLAB commands in this example, add the `DocPolynomTest.m` file to a folder on your MATLAB path.

Write Test to Verify Constructor. Create a function, `testConstructor`, using the `verifyClass` method to test the `DocPolynom` class constructor.

```
function testConstructor(testCase)
 p = DocPolynom([1, 0, 1]);
 testCase.verifyClass(p, ?DocPolynom);
end
```

Write Tests to Verify Operations. In the `testAddition` function, use the `verifyEqual` method to test the equation  $(x^2 + 1) + (5x + 2) = x^2 + 5x + 3$ . The `verifyEqual` method includes this equation in the diagnostic argument.

```
function testAddition(testCase)
 p1 = DocPolynom([1, 0, 1]);
 p2 = DocPolynom([5, 2]);

 actual = p1 + p2;
```

```
expected = DocPolynom([1, 5, 3]);

msg = [testCase.msgEqn,...
 '(x^2 + 1) + (5*x + 2) = x^2 + 5*x + 3'];
testCase.verifyEqual(actual, expected, msg);
end
```

The function, `testMultiplication`, tests multiplication operations.

Run the tests in the `DocPolynomTest` test case.

```
tc = DocPolynomTest;
ts = matlab.unittest.TestSuite.fromClass(?DocPolynomTest);
res = run(ts);
```

```
Running DocPolynomTest
...
Done DocPolynomTest
```

---

All tests passed.

## See Also

[TestCase](#) | [Assumable](#) | [FatalAssertable](#) | [Assertable](#) |  
[matlab.unittest.qualifications](#) | [QualificationEventData](#)

## Concepts

## External Web Sites

- [Four-Phase Test](#)

# matlab.unittest.qualifications.Verifiable.verifyClass

---

**Purpose** Verify exact class of specified value

**Syntax**

```
verifyClass(verifiable,actual,className)
verifyClass(verifiable,actual,metaClass)
verifyClass(__,diagnostic)
```

**Description**

`verifyClass(verifiable,actual,className)` verifies that `actual` is a MATLAB value whose class is the class specified by `className`.

`verifyClass(verifiable,actual,metaClass)` verifies that `actual` is a MATLAB value whose class is the class specified by the `meta.class` instance `metaClass`. The instance must be an exact class match. Use `verifyInstanceOf` to verify inclusion in a class hierarchy.

`verifyClass(__,diagnostic)` also displays the diagnostic information in `diagnostic` upon a failure.

**Tips**

- The method is functionally equivalent to the following methods:

```
import matlab.unittest.constraints.IsOfClass;
verifiable.verifyThat(actual, IsOfClass(className));
verifiable.verifyThat(actual, IsOfClass(metaClass));
```

There exists more functionality when using the `IsOfClass` constraint directly via `verifyThat`.

## Input Arguments

### **verifiable**

The `matlab.unittest.TestCase` instance which is used to pass or fail the verification in conjunction with the test running framework.

### **actual**

The value to test.

### **className**

Name of class, specified as a string.

### **metaClass**

An instance of meta.class.

## **diagnostic**

Diagnostic information to display upon a failure, specified as one of the following:

- string
- function handle
- matlab.unittest.diagnostics.Diagnostic object

Diagnostic values can be nonscalar. For more information, see `matlab.unittest.diagnostics.Diagnostic`.

## **Examples**

### **Test a Class**

These interactive tests verify the class of the number, 5.

Create a TestCase object and the value to test.

```
testCase = matlab.unittest.TestCase.forInteractiveUse;
actvalue = 5;
```

Verify class of actvalue is double.

```
verifyClass(testCase, actvalue, 'double');
```

```
Interactive verification passed.
```

Verify class of actvalue is char.

```
verifyClass(testCase, actvalue, 'char');
```

```
Interactive verification failed.
```

```

Framework Diagnostic:

```

# matlab.unittest.qualifications.Verifiable.verifyClass

---

```
verifyClass failed.
--> The value's class is incorrect.
```

```
Actual Class:
 double
Expected Class:
 char
```

```
Actual Value:
 5
```

Test fails.

## Test a Function Handle

These interactive tests verify function handles, specified as a meta.class instance, ?function\_handle.

Create a TestCase object.

```
testCase = matlab.unittest.TestCase.forInteractiveUse;
```

Create a function handle.

```
fh = @sin;
verifyClass(testCase, fh, ?function_handle);
```

```
Interactive verification passed.
```

Test the function name.

```
fh = 'sin';
verifyClass(testCase, fh, ?function_handle);
```

```
Interactive verification failed.
```

```

Framework Diagnostic:

```

```
verifyClass failed.
--> The value's class is incorrect.
```

```
Actual Class:
 char
Expected Class:
 function_handle
```

```
Actual Value:
 sin
```

Test fails.

## **Test a Derived Class**

Verify that a derived class is not the same class as its base class.

Create a class, BaseExample.

```
classdef BaseExample
end
```

Create a derived class, DerivedExample.

```
classdef DerivedExample < BaseExample
end
```

Verify the classes are not equal.

```
testCase = matlab.unittest.TestCase.forInteractiveUse;
verifyClass(testCase, DerivedExample(), ?BaseExample);
```

```
Interactive verification failed.
```

```

Framework Diagnostic:

verifyClass failed.
--> The value's class is incorrect.
```

# matlab.unittest.qualifications.Verifiable.verifyClass

---

```
Actual Class:
 DerivedExample
Expected Class:
 BaseExample
```

```
Actual Value:
 DerivedExample with no properties.
```

Test fails.

## Test Class of Output Value

Use `verifyClass` to test the `add5` function returns a double value.

Function for unit testing:

```
function res = add5(x)
%ADD5 Increment input by 5.
if ~isa(x,'numeric')
 error('add5:InputMustBeNumeric','Input must be numeric.');
```

TestCase class containing test methods:

```
classdef Add5Test < matlab.unittest.TestCase
 methods (Test)
 function testDoubleOut(testCase)
 actOutput = add5(1);
 testCase.verifyClass(actOutput,'double');
```



Create a test suite from the Add5Test class file.

```
suite = matlab.unittest.TestSuite.fromFile('Add5Test.m');

result = run(suite);
```

```
Running Add5Test
```

```
..
```

```
Done Add5Test
```

---

## See Also

```
matlab.unittest.constraints | matlab.unittest.qualifications
| verifyThat | verifyInstanceOf |
matlab.unittest.constraints.IsOfClass |
matlab.unittest.diagnostics.Diagnostic
```

# matlab.unittest.qualifications.Verifiable.verifyEmpty

---

<b>Purpose</b>	Verify value is empty
<b>Syntax</b>	<pre>verifyEmpty(verifiable,actual) verifyEmpty( __,diagnostic)</pre>
<b>Description</b>	<p><code>verifyEmpty(verifiable,actual)</code> verifies that <code>actual</code> is an empty MATLAB value.</p> <p><code>verifyEmpty( __,diagnostic)</code> also displays the diagnostic information in <code>diagnostic</code> upon a failure.</p>
<b>Tips</b>	<ul style="list-style-type: none"><li>• This method is functionally equivalent to: <pre>import matlab.unittest.constraints.IsEmpty; verifiable.verifyThat(actual, IsEmpty());</pre><p>There exists more functionality when using the <code>IsEmpty</code> constraint directly via <code>verifyThat</code>.</p></li></ul>
<b>Input Arguments</b>	<p><b>verifiable</b></p> <p>The <code>matlab.unittest.TestCase</code> instance which is used to pass or fail the verification in conjunction with the test running framework.</p> <p><b>actual</b></p> <p>The value to test.</p> <p><b>diagnostic</b></p> <p>Diagnostic information to display upon a failure, specified as one of the following:</p> <ul style="list-style-type: none"><li>• string</li><li>• function handle</li><li>• <code>matlab.unittest.diagnostics.Diagnostic</code> object</li></ul>

Diagnostic values can be nonscalar. For more information, see `matlab.unittest.diagnostics.Diagnostic`.

## Examples **Test for Empty Strings**

Create a `TestCase` object.

```
testCase = matlab.unittest.TestCase.forInteractiveUse;
verifyEmpty(testCase, '');
```

```
Interactive verification passed.
```

## **Test for Empty Arrays**

An array with any zero dimension is empty.

```
testCase = matlab.unittest.TestCase.forInteractiveUse;
verifyEmpty(testCase, ones(2, 5, 0, 3));
```

```
Interactive verification passed.
```

```
verifyEmpty(testCase, [2 3], 'Array is not empty.');
```

```
Interactive verification failed.
```

```

Test Diagnostic:
```

```

Array is not empty.
```

```

Framework Diagnostic:
```

```

verifyEmpty failed.
--> The value must be empty.
--> The value has a size of [1 2].
```

```
Actual Value:
```

# matlab.unittest.qualifications.Verifiable.verifyEmpty

---

2 3

Test failed.

## Test for Empty Cell Arrays

Test empty cell array, {}.

```
matlab.unittest.TestCase.forInteractiveUse;
verifyEmpty(testCase, {}, 'Cell array is not empty.');
```

Interactive verification passed.

A cell array of empty arrays is not empty.

```
verifyEmpty(testCase, {[], [], []}, 'Cell array is not empty.');
```

Interactive verification failed.

```

Test Diagnostic:

Cell array is not empty.
```

```

Framework Diagnostic:

verifyEmpty failed.
--> The value must be empty.
--> The value has a size of [1 3].
```

```
Actual Value:
 [] [] []
```

Test failed.

## Test for Empty Test Suite

Test for empty object, emptyTestSuite.

# matlab.unittest.qualifications.Verifiable.verifyEmpty

---

```
testCase = matlab.unittest.TestCase.forInteractiveUse;
emptyTestSuite = matlab.unittest.TestSuite.empty;
verifyEmpty(testCase, emptyTestSuite);
```

Interactive verification passed.

## See Also

```
matlab.unittest.constraints | matlab.unittest.qualifications
| verifyThat | verifyNotEmpty | isempty
| matlab.unittest.constraints.IsEmpty |
matlab.unittest.diagnostics.Diagnostic
```

# matlab.unittest.qualifications.Verifiable.verifyEqual

---

**Purpose** Verify value is equal to specified value

**Syntax** `verifyEqual(verifyable,actual,expected)`  
`verifyEqual( ___,Name,Value)`  
`verifyEqual( ___,diagnostic)`

**Description** `verifyEqual(verifyable,actual,expected)` verifies that `actual` is strictly equal to `expected`.

`verifyEqual( ___,Name,Value)` verifies equality with additional options specified by one or more `Name,Value` pair arguments.

`verifyEqual( ___,diagnostic)` also displays the diagnostic information in `diagnostic` upon a failure

**Tips** • This method is functionally equivalent to any of the following:

```
import matlab.unittest.constraints.IsEqualTo;
verifyable.verifyThat(actual, IsEqualTo(expected));
```

```
import matlab.unittest.constraints.IsEqualTo;
import matlab.unittest.constraints.AbsoluteTolerance;
verifyable.verifyThat(actual, IsEqualTo(expected, ...
 'Within', AbsoluteTolerance(abstol)));
```

```
import matlab.unittest.constraints.IsEqualTo;
import matlab.unittest.constraints.RelativeTolerance;
verifyable.verifyThat(actual, IsEqualTo(expected, ...
 'Within', RelativeTolerance(reltol)));
```

```
import matlab.unittest.constraints.IsEqualTo;
import matlab.unittest.constraints.AbsoluteTolerance;
import matlab.unittest.constraints.RelativeTolerance;
verifyable.verifyThat(actual, IsEqualTo(expected, ...
 'Within', AbsoluteTolerance(abstol) | RelativeTolerance(reltol)));
```

There exists more functionality when using the `IsEqualTo`, `RelativeTolerance`, and `IsEqualTo` constraints directly via `verifyThat`.

## Input Arguments

### **verifiable**

The `matlab.unittest.TestCase` instance which is used to pass or fail the verification in conjunction with the test running framework.

### **actual**

The value to test.

### **expected**

Expected value.

### **diagnostic**

Diagnostic information to display upon a failure, specified as one of the following:

- string
- function handle
- `matlab.unittest.diagnostics.Diagnostic` object

Diagnostic values can be nonscalar. For more information, see `matlab.unittest.diagnostics.Diagnostic`.

## **Name-Value Pair Arguments**

Specify optional comma-separated pairs of `Name, Value` arguments. `Name` is the argument name and `Value` is the corresponding value. `Name` must appear inside single quotes ( ' '). You can specify several name and value pair arguments in any order as `Name1, Value1, ..., NameN, ValueN`.

**'AbsTol'**

**'RelTol'**

## Examples

### Comparing Numeric Values

Numeric values are equivalent if they are of the same class with equivalent size, complexity, and sparsity.

Create a TestCase object for interactive testing.

```
testCase = matlab.unittest.TestCase.forInteractiveUse;
```

A value is equal to itself.

```
verifyEqual(testCase, 5, 5);
```

Interactive verification passed.

Values must have equal sizes.

```
verifyEqual(testCase, [5 5], 5);
```

Interactive verification failed.

```

Framework Diagnostic:

verifyEqual failed.
--> NumericComparator failed.
 --> Sizes do not match.
```

```
Actual double size:
 1 2
Expected double size:
 1 1
```

```
Actual Value:
 5 5
Expected Value:
 5
```

Test failed.



## Test Classes

```
testCase = matlab.unittest.TestCase.forInteractiveUse;
verifyEqual(testCase, int8(5), int16(5));
```

Interactive verification failed.

```

Framework Diagnostic:

verifyEqual failed.
--> NumericComparator failed.
 --> Classes do not match.
```

```
Actual Class:
 int8
Expected Class:
 int16
```

```
Actual Value:
 5
Expected Value:
 5
```

Test failed.

## Test Cell Arrays

Each element of a cell array must be equal in value, class, and size.

```
testCase = matlab.unittest.TestCase.forInteractiveUse;
verifyEqual(testCase, {'cell', struct, 5}, {'cell', struct, 5});
```

Interactive verification passed.

## Test Numeric Tolerances

```
testCase = matlab.unittest.TestCase.forInteractiveUse;
verifyEqual(testCase, 4.95, 5);
```

# matlab.unittest.qualifications.Verifiable.verifyEqual

---

```
Interactive verification failed.
```

```

Test Diagnostic:

```

```
4.95 is not equal to 5
```

```

Framework Diagnostic:

```

```
verifyEqual failed.
```

```
--> NumericComparator failed.
```

```
 --> The values are not equal using "isequaln".
```

```
Actual Value:
```

```
 4.9500000000000000
```

```
Expected Value:
```

```
 5
```

```
Test failed.
```

```
verifyEqual(testCase, 1.5, 2, 'AbsTol', 1)
```

```
Interactive verification passed.
```

```
verifyEqual(testCase, 1.5, 2, 'RelTol', 0.1, ...
```

```
 'Difference between actual and expected exceeds relative tolerance')
```

```
Interactive verification failed.
```

```

Test Diagnostic:

```

```
Difference between actual and expected exceeds relative tolerance
```

```

```

```
Framework Diagnostic:

verifyEqual failed.
--> NumericComparator failed.
 --> The values are not equal using "isequaln".
 --> RelativeTolerance failed.
 --> The value was not within relative tolerance.

 Tolerance Definition:
 abs(expected - actual) <= tolerance .* abs(expected)
 Tolerance Value:
 0.10000000000000000

Actual Value:
 1.5000000000000000
Expected Value:
 2
```

Test failed.

## See Also

```
verifyThat | verifyNotEqual |
matlab.unittest.constraints.IsEqualTo |
matlab.unittest.constraints.AbsoluteTolerance
| matlab.unittest.constraints.RelativeTolerance
| matlab.unittest.diagnostics.Diagnostic |
matlab.unittest.constraints | matlab.unittest.qualifications
```

# matlab.unittest.qualifications.Verifiable.verifyError

---

**Purpose** Verify function throws specified exception

**Syntax**

```
verifyError(verifiable,actual,identifier)
verifyError(verifiable,actual,metaClass)
verifyError(__,diagnostic)
```

**Description** `verifyError(verifiable,actual,identifier)` verifies that `actual` is a function handle that throws an exception with an error identifier that is equal to `identifier`.

`verifyError(verifiable,actual,metaClass)` verifies that `actual` is a function handle that throws an exception whose type is defined by the `meta.class` instance specified in `metaClass`. This method does not require the instance to be an exact class match, but rather it must be in the specified class hierarchy, and that hierarchy must include the `MException` class.

`verifyError(__,diagnostic)` also displays the diagnostic information in `diagnostic` upon a failure.

**Tips**

- This method is functionally equivalent to:

```
import matlab.unittest.constraints.Throws;
verifiable.verifyThat(actual, Throws(identifier));
verifiable.verifyThat(actual, Throws(metaClass));
```

There exists more functionality when using the `Throws` constraint directly via `verifyThat`.

## Input Arguments

### **verifiable**

The `matlab.unittest.TestCase` instance which is used to pass or fail the verification in conjunction with the test running framework.

### **actual**

The value to test.

### **identifier**

Error identifier, specified as a string.

## metaClass

An instance of meta.class.

## diagnostic

Diagnostic information to display upon a failure, specified as one of the following:

- string
- function handle
- matlab.unittest.diagnostics.Diagnostic object

Diagnostic values can be nonscalar. For more information, see `matlab.unittest.diagnostics.Diagnostic`.

## Examples

### Test for Error IDs

```
testCase = matlab.unittest.TestCase.forInteractiveUse;

% Passing scenarios
%%
verifyError(testCase, @() error('SOME:error:id','Error!'), 'SOME:error:
verifyError(testCase, @testCase.assertFail, ...
 ?matlab.unittest.qualifications.AssertionFailedException);

% Failing scenarios
%%
verifyError(testCase, 5, 'some:id', '5 is not a function handle');
verifyError(testCase, @testCase.verifyFail, ...
 ?matlab.unittest.qualifications.AssertionFailedException, ...
 'Verifications dont throw exceptions. ');
verifyError(testCase, @() error('SOME:id'), 'OTHER:id', 'Wrong id');
verifyError(testCase, @() error('whoops'), ...
 ?matlab.unittest.qualifications.AssertionFailedException, ...
 'Wrong type of exception thrown');
```

# matlab.unittest.qualifications.Verifiable.verifyError

---

## Test Error Condition

Create `testNonNumericInput` to test if function throws expected error message, `add5:InputMustBeNumeric`, for unexpected condition, input is char.

Function for unit testing:

```
function res = add5(x)
%ADD5 Increment input by 5.
if ~isa(x,'numeric')
 error('add5:InputMustBeNumeric','Input must be numeric.');
```

TestCase class containing test methods:

```
classdef Add5Test < matlab.unittest.TestCase
 methods (Test)
 function testDoubleOut(testCase)
 actOutput = add5(1);
 testCase.verifyClass(actOutput,'double');
 end
 function testNonNumericInput(testCase)
 testCase.verifyError(@()add5('0'),'add5:InputMustBeNumeric');
```

Create a test suite from the `Add5Test` class file.

```
suite = matlab.unittest.TestSuite.fromFile('Add5Test.m');
```

```
result = run(suite);
```

```
Running Add5Test
```

```
..
Done Add5Test
```

---

## See Also

[verifyThat](#) | [verifyWarning](#) | [MException](#) | [error](#) | [matlab.unittest.constraints.Throws](#) | [matlab.unittest.diagnostics.Diagnostic](#) | [matlab.unittest.constraints](#) | [matlab.unittest.qualifications](#)

# matlab.unittest.qualifications.Verifiable.verifyFail

---

**Purpose** Produce unconditional verification failure

**Syntax** `verifyFail(verifiable)`  
`verifyFail(verifiable,diagnostic)`

**Description** `verifyFail(verifiable)` produces an unconditional verification failure when encountered.

`verifyFail(verifiable,diagnostic)` also displays the diagnostic information in `diagnostic` upon a failure.

## Input Arguments

### **verifiable**

The `matlab.unittest.TestCase` instance which is used to pass or fail the verification in conjunction with the test running framework.

### **diagnostic**

Diagnostic information to display upon a failure, specified as one of the following:

- string
- function handle
- `matlab.unittest.diagnostics.Diagnostic` object

Diagnostic values can be nonscalar. For more information, see `matlab.unittest.diagnostics.Diagnostic`.

## Examples

### **Test for Failure Condition**

An example of where this method may be used is in a callback function that should not be executed in a given scenario. A test can confirm this does not occur by unconditionally performing a failure if the code path is reached.

Create a handle class, `MyHandle`, with a `SomethingHappened` event.



```
classdef MyHandle < handle
 events
 SomethingHappened
 end
end
```

Create a file, `ListenerTest`, on your MATLAB path that contains the following `TestCase` class.

```
classdef ListenerTest < matlab.unittest.TestCase
 methods(Test)
 function testDisabledListeners(testCase)
 h = MyHandle;

 % Add a listener to a test helper method
 listener = h.addlistener('SomethingHappened', ...
 @testCase.shouldNotGetCalled);

 % Passing scenario (code path is not reached)
 %%%%%%%%%%%
 % Disabled listener should not invoke callbacks
 listener.Enabled = false;
 h.notify('SomethingHappened');

 % Failing scenario (code path is reached)
 %%%%%%%%%%%
 % Enabled listener invoke callback and fail
 listener.Enabled = true;
 h.notify('SomethingHappened');
 end
 end

 methods
 function shouldNotGetCalled(testCase, ~, ~)
 % A test helper callback method that should not execute
 testCase.verifyFail('This listener callback should not have
 end
```

# matlab.unittest.qualifications.Verifiable.verifyFail

---

```
end
```

```
end
```

From the command prompt, run the test.

```
run(ListenerTest);
```

```
Running ListenerTest
```

```
=====
Verification failed in ListenerTest/testDisabledListeners.
```

```

Test Diagnostic:
```

```

This listener callback should not have executed
```

```

Stack Information:
```

```

In C:\Desktop\ListenerTest.m (ListenerTest.shouldNotGetCalled) at 27
In C:\Desktop\ListenerTest.m (@(varargin)testCase.shouldNotGetCalled
In C:\Desktop\ListenerTest.m (ListenerTest.testDisabledListeners) at
=====
```

```
.
Done ListenerTest
```

```

Failure Summary:
```

Name	Failed	Incomplete	Reason(s)
ListenerTest/testDisabledListeners	X		Failed by ve

## See Also

[matlab.unittest.diagnostics.Diagnostic](#) |  
[matlab.unittest.constraints](#) | [matlab.unittest.qualifications](#)

# matlab.unittest.qualifications.Verifiable.verifyFalse

---

## Purpose

Verify value is false

## Syntax

```
verifyFalse(verifiable,actual)
verifyFalse(__ ,diagnostic)
```

## Description

`verifyFalse(verifiable,actual)` verifies that `actual` is a scalar logical with the value of false.

`verifyFalse( __ ,diagnostic)` also displays the diagnostic information in `diagnostic` upon a failure.

## Tips

- This method passes if and only if the actual value is a scalar logical with a value of false. Therefore, entities such as empty arrays, false valued arrays, and zero doubles produce failures when used in this method, despite these entities exhibiting "false-like" behavior such as bypassing the execution of code inside of "if" statements.
- This method is functionally equivalent to:

```
import matlab.unittest.constraints.IsFalse;
verifiable.verifyThat(actual,.IsFalse());
```

There exists more functionality when using the `IsFalse` constraint directly via `verifyThat`.

- Unlike `verifyTrue`, this method may create a new constraint for each call. For performance critical uses, consider using `verifyTrue`.

## Input Arguments

### **verifiable**

The `matlab.unittest.TestCase` instance which is used to pass or fail the verification in conjunction with the test running framework.

### **actual**

The value to test.

### **diagnostic**

# matlab.unittest.qualifications.Verifiable.verifyFalse

---

Diagnostic information to display upon a failure, specified as one of the following:

- string
- function handle
- matlab.unittest.diagnostics.Diagnostic object

Diagnostic values can be nonscalar. For more information, see `matlab.unittest.diagnostics.Diagnostic`.

## Examples

### Test MATLAB Logical Functions

Create a TestCase object for interactive testing.

```
testCase = matlab.unittest.TestCase.forInteractiveUse;
```

Test true.

```
verifyFalse(testCase, true);
```

```
Interactive verification failed.
```

```

Framework Diagnostic:

```

```
verifyFalse failed.
```

```
--> The value must evaluate to "false".
```

```
Actual Value:
```

```
 1
```

Test failed.

Test false.

```
verifyFalse(testCase, false);
```

Interactive verification passed.

## Test the Value 0

The number 0 is a double value, not a logical value.

```
testCase = matlab.unittest.TestCase.forInteractiveUse;
verifyFalse(testCase, 0);
```

Interactive verification failed.

```

Framework Diagnostic:

verifyFalse failed.
--> The value must be logical. It is of type "double".
```

```
Actual Value:
 0
```

Test failed.

## Test Array of Logical Values

To be false, the value must be scalar.

```
testCase = matlab.unittest.TestCase.forInteractiveUse;
verifyFalse(testCase, [false false false]);
```

Interactive verification failed.

```

Framework Diagnostic:

verifyFalse failed.
--> The value must be scalar. It has a size of [1 3].
```

```
Actual Value:
 0 0 0
```

# matlab.unittest.qualifications.Verifiable.verifyFalse

---

Test failed.

Test an array of mixed logical values.

```
verifyFalse(testCase, [false true false], ...
 'A mixed array of logicals is not the one false value');
```

Interactive verification failed.

-----

Test Diagnostic:

-----

A mixed array of logicals is not the one false value

-----

Framework Diagnostic:

-----

verifyFalse failed.

--> The value must be scalar. It has a size of [1 3].

Actual Value:

0 1 0

Test failed.

## See Also

```
verifyThat | verifyTrue |
matlab.unittest.diagnostics.Diagnostic
| matlab.unittest.constraints.IsFalse |
matlab.unittest.constraints | matlab.unittest.qualifications
```

**Purpose** Verify value is greater than specified value

**Syntax** `verifyGreaterThan(verifiable,actual,floor)`  
`verifyGreaterThan(__,diagnostic)`

**Description** `verifyGreaterThan(verifiable,actual,floor)` verifies that all elements of `actual` are greater than all the elements of `floor`.  
`verifyGreaterThan(__,diagnostic)` also displays the diagnostic information in `diagnostic` upon a failure.

**Tips**

- This method is functionally equivalent to:

```
matlab.unittest.constraints.IsGreaterThan;
verifiable.verifyThat(actual, IsGreaterThan(floor));
```

There exists more functionality when using the `IsGreaterThan` constraint directly via `verifyThat`.

## Input Arguments

### **verifiable**

The `matlab.unittest.TestCase` instance which is used to pass or fail the verification in conjunction with the test running framework.

### **actual**

The value to test. `actual` must be the same size as `floor` unless either one is scalar, at which point scalar expansion occurs.

### **floor**

Minimum value, exclusive.

### **diagnostic**

Diagnostic information to display upon a failure, specified as one of the following:

- string

# matlab.unittest.qualifications.Verifiable.verifyGreaterThan

---

- function handle
- matlab.unittest.diagnostics.Diagnostic object

Diagnostic values can be nonscalar. For more information, see `matlab.unittest.diagnostics.Diagnostic`.

## Examples

### Compare Two Numbers

Create a `TestCase` object for interactive testing.

```
testCase = matlab.unittest.TestCase.forInteractiveUse;
```

Verify 3 is greater than 2.

```
verifyGreaterThan(testCase, 3, 2);
```

```
Interactive verification passed.
```

Test if 5 is greater than 9.

```
verifyGreaterThan(testCase, 5, 9);
```

```
Interactive verification failed.
```

```

Framework Diagnostic:

```

```
verifyGreaterThan failed.
```

```
--> The value must be greater than the minimum value.
```

```
Actual Value:
```

```
5
```

```
Minimum Value (Exclusive):
```

```
9
```

```
Test failed.
```



## Compare an Array to a Scalar

Test if each element is greater than the FLOOR value, 2.

```
testCase = matlab.unittest.TestCase.forInteractiveUse;
verifyGreaterThan(testCase, [5 6 7], 2);
```

```
Interactive verification passed.
```

Test if value 5 is greater than each element in the FLOOR array, [1 2 3].

```
verifyGreaterThan(testCase, 5, [1 2 3]);
```

```
Interactive verification passed.
```

Test if each element in the matrix is greater than the FLOOR value, 4.

```
verifyGreaterThan(testCase, [1 2 3; 4 5 6], 4);
```

```
Interactive verification failed.
```

```

Framework Diagnostic:

```

```
verifyGreaterThan failed.
```

```
--> Each element must be greater than the minimum value.
```

```
Failing Indices:
```

```
 1 2 3 5
```

```
Actual Value:
```

```
 1 2 3
 4 5 6
```

```
Minimum Value (Exclusive):
```

```
 4
```

```
Test failed.
```

## Compare Arrays

Test if each element is greater than each corresponding element of the FLOOR array, [4 -9 0].

```
testCase = matlab.unittest.TestCase.forInteractiveUse;
verifyGreaterThan(testCase, [5 -3 2], [4 -9 0]);
```

Interactive verification passed.

Compare an array to itself.

```
verifyGreaterThan(testCase, eye(2), eye(2));
```

Interactive verification failed.

```

Framework Diagnostic:

```

verifyGreaterThan failed.

--> Each element must be greater than each corresponding element of the m

Failing Indices:

1	2	3	4
---	---	---	---

Actual Value:

1	0
0	1

Minimum Value (Exclusive):

1	0
0	1

Test failed.

## See Also

[verifyThat](#) | [verifyGreaterThanOrEqual](#) |  
[verifyLessThanOrEqual](#) | [verifyLessThan](#) | [gt](#)  
| [matlab.unittest.constraints.IsGreaterThan](#)

| matlab.unittest.diagnostics.Diagnostic |  
matlab.unittest.constraints | matlab.unittest.qualifications

## Purpose

Verify value is greater than or equal to specified value

## Syntax

```
verifyGreaterThanOrEqualTo(verifiable,actual,floor)
verifyGreaterThanOrEqualTo(___,diagnostic)
```

## Description

`verifyGreaterThanOrEqualTo(verifiable,actual,floor)` that all elements of `actual` are greater than or equal to all the elements of `floor`.

`verifyGreaterThanOrEqualTo( ___,diagnostic)` also displays the diagnostic information in `diagnostic` upon a failure.

## Tips

- This method is functionally equivalent to:

```
import matlab.unittest.constraints.IsGreaterThanOrEqualTo;
verifiable.verifyThat(actual, IsGreaterThanOrEqualTo(floor));
```

There exists more functionality when using the `IsGreaterThanOrEqualTo` constraint directly via `verifyThat`.

## Input Arguments

### **verifiable**

The `matlab.unittest.TestCase` instance which is used to pass or fail the verification in conjunction with the test running framework.

### **actual**

The value to test. `actual` must be the same size as `floor` unless either one is scalar, at which point scalar expansion occurs.

### **floor**

Minimum value.

### **diagnostic**

Diagnostic information to display upon a failure, specified as one of the following:

- string

- function handle
- matlab.unittest.diagnostics.Diagnostic object

Diagnostic values can be nonscalar. For more information, see `matlab.unittest.diagnostics.Diagnostic`.

## Examples

### Compare Two Numbers

Create a `TestCase` object for interactive testing.

```
testCase = matlab.unittest.TestCase.forInteractiveUse;
```

Verify 3 is greater than 2.

```
verifyGreaterThanOrEqualTo(testCase, 3, 2);
```

```
Interactive verification passed.
```

Verify 3 is greater than or equal to 3.

```
verifyGreaterThanOrEqualTo(testCase, 3, 3);
```

```
Interactive verification passed.
```

Test if 5 is greater than 9.

```
verifyGreaterThanOrEqualTo(testCase, 5, 9);
```

```
Interactive verification failed.
```

```

Framework Diagnostic:

```

```
verifyGreaterThanOrEqualTo failed.
```

```
--> The value must be greater than or equal to the minimum value.
```

```
Actual Value:
```

```
5
```

```
Minimum Value (Inclusive):
 9
```

Test failed.

## Compare an Array to a Scalar

Test if each element is greater than or equal to the FLOOR value, 2.

```
testCase = matlab.unittest.TestCase.forInteractiveUse;
verifyGreaterThanOrEqualTo(testCase, [5 2 7], 2);
```

Interactive verification passed.

Test if each element in the matrix is greater than or equal to the FLOOR value, 4.

```
verifyGreaterThanOrEqualTo(testCase, [1 2 3; 4 5 6], 4);
```

Interactive verification failed.

```

Framework Diagnostic:

```

```
verifyGreaterThanOrEqualTo failed.
```

```
--> Each element must be greater than or equal to the minimum value.
```

```
Failing Indices:
```

```
 1 3 5
```

```
Actual Value:
```

```
 1 2 3
 4 5 6
```

```
Minimum Value (Inclusive):
```

```
 4
```

## Compare Arrays

Test if each element is greater than or equal to each corresponding element of the FLOOR array, [4 -3 0].

```
testCase = matlab.unittest.TestCase.forInteractiveUse;
verifyGreaterThanOrEqualTo(testCase, [5 -3 2], [4 -3 0]);
```

Interactive verification passed.

Compare an array to itself.

```
verifyGreaterThanOrEqualTo(testCase, eye(2), eye(2));
```

Interactive verification passed.

## See Also

[verifyThat](#) | [verifyGreaterThan](#) |  
[verifyLessThan](#) | [verifyLessThanOrEqualTo](#) | [ge](#) |  
[matlab.unittest.constraints.IsGreaterThanOrEqualTo](#)  
| [matlab.unittest.diagnostics.Diagnostic](#) |  
[matlab.unittest.constraints](#) | [matlab.unittest.qualifications](#)

# matlab.unittest.qualifications.Verifiable.verifyInstanceOf

## Purpose

Verify value is object of specified type

## Syntax

```
verifyInstanceOf(verifiable,actual,className)
verifyInstanceOf(verifiable,actual,metaClass)
verifyInstanceOf(___,diagnostic)
```

## Description

`verifyInstanceOf(verifiable,actual,className)` verifies that `actual` is a MATLAB value whose class is the class specified by `className`.

`verifyInstanceOf(verifiable,actual,metaClass)` `actual` is a MATLAB value whose class is the class specified by the `meta.class` instance `metaClass`.

`verifyInstanceOf(___,diagnostic)` also displays the diagnostic information in `diagnostic` upon a failure.

## Tips

- This method is functionally equivalent to:

```
import matlab.unittest.constraints.IsInstanceOf;
verifiable.verifyThat(actual, IsInstanceOf(className));
verifiable.verifyThat(actual, IsInstanceOf(metaClass));
```

There exists more functionality when using the `IsInstanceOf` constraint directly via `verifyThat`.

## Input Arguments

### **verifiable**

The `matlab.unittest.TestCase` instance which is used to pass or fail the verification in conjunction with the test running framework.

### **actual**

The value to test.

### **className**

Name of class, specified as a string.

### **metaClass**



An instance of meta.class.

## **diagnostic**

Diagnostic information to display upon a failure, specified as one of the following:

- string
- function handle
- matlab.unittest.diagnostics.Diagnostic object

Diagnostic values can be nonscalar. For more information, see `matlab.unittest.diagnostics.Diagnostic`.

## **Examples**

### **Test a Class**

These interactive tests verify the class of the number, 5.

Create a TestCase object and the value to test.

```
testCase = matlab.unittest.TestCase.forInteractiveUse;
actvalue = 5;
```

Verify actvalue is an instance of class double.

```
verifyInstanceOf(testCase, actvalue, 'double');
```

```
Interactive verification passed.
```

Verify if actvalue is an instance of char.

```
verifyInstanceOf(testCase, 5, 'char');
```

```
Interactive verification failed.
```

```

Framework Diagnostic:

```

```
verifyInstanceOf failed.
```

# matlab.unittest.qualifications.Verifiable.verifyInstanceOf

```
--> The value must be an instance of the expected type.
```

```
Actual Class:
 double
Expected Type:
 char
```

```
Actual Value:
 5
```

Test failed.

## Test a Function Handle

These tests verify function handles, specified as a meta.class instance, ?function\_handle.

Create a function handle.

```
fh = @sin;
testCase = matlab.unittest.TestCase.forInteractiveUse;
verifyInstanceOf(testCase, fh, ?function_handle);
```

```
Interactive verification passed.
```

Test the function name.

```
fh = 'sin';
verifyInstanceOf(testCase, fh, ?function_handle);
```

```
Interactive verification failed.
```

```

Framework Diagnostic:

```

```
verifyInstanceOf failed.
```

```
--> The value must be an instance of the expected type.
```

```
Actual Class:
```

```
char
Expected Type:
function_handle
```

```
Actual Value:
sin
```

Test failed.

## Test a Derived Class

Verify that a derived class is not the same class as its base class.

Create a class, BaseExample.

```
classdef BaseExample
end
```

Create a derived class, DerivedExample.

```
classdef DerivedExample < BaseExample
end
```

Verify DerivedExample is an instance of BaseExample.

```
testCase = matlab.unittest.TestCase.forInteractiveUse;
testCase.verifyInstanceOf(DerivedExample(), ?BaseExample);
```

```
Interactive verification passed.
```

Verify BaseExample is not an instance of DerivedExample.

```
testCase.verifyInstanceOf(BaseExample(), ?DerivedExample);
```

```
Interactive verification failed.
```

```

Framework Diagnostic:

```

# matlab.unittest.qualifications.Verifiable.verifyInstanceOf

---

```
verifyInstanceOf failed.
--> The value must be an instance of the expected type.
```

```
Actual Class:
 BaseExample
Expected Type:
 DerivedExample
```

```
Actual Value:
 BaseExample with no properties.
```

Test failed.

## See Also

```
verifyThat | verifyClass | isa |
matlab.unittest.diagnostics.Diagnostic |
matlab.unittest.constraints.IsInstanceOf |
matlab.unittest.constraints | matlab.unittest.qualifications
```

# matlab.unittest.qualifications.Verifiable.verifyLength

---

## Purpose

Verify value has specified length

## Syntax

```
verifyLength(verifiable,actual,expectedLength)
verifyLength(___,diagnostic)
```

## Description

`verifyLength(verifiable,actual,expectedLength)` verifies that `actual` is a MATLAB array whose length is `expectedLength`.

`verifyLength( ___,diagnostic)` also displays the diagnostic information in `diagnostic` upon a failure.

## Tips

- This method is functionally equivalent to:

```
import matlab.unittest.constraints.HasLength;
verifiable.verifyThat(actual, HasLength(expectedLength));
```

There exists more functionality when using the `HasLength` constraint directly via `verifyThat`.

## Input Arguments

### **verifiable**

The `matlab.unittest.TestCase` instance which is used to pass or fail the verification in conjunction with the test running framework.

### **actual**

The value to test.

### **expectedLength**

The length of an array is defined as the largest dimension of that array.

### **diagnostic**

Diagnostic information to display upon a failure, specified as one of the following:

- string

# matlab.unittest.qualifications.Verifiable.verifyLength

---

- function handle
- matlab.unittest.diagnostics.Diagnostic object

Diagnostic values can be nonscalar. For more information, see `matlab.unittest.diagnostics.Diagnostic`.

## Examples

### Test Array Lengths

Create a `TestCase` object for interactive testing.

```
testCase = matlab.unittest.TestCase.forInteractiveUse;
```

Verify length of array is the expected value, 5.

```
verifyLength(testCase, ones(2, 5, 3), 5, 'User diagnostic');
```

```
Interactive verification passed.
```

Length of array is not the expected value, 3.

```
verifyLength(testCase, [2 3], 3);
```

```
Interactive verification failed.
```

```

Framework Diagnostic:

```

```
verifyLength failed.
```

```
--> The array has an incorrect length.
```

```
Actual Length:
```

```
2
```

```
Expected Length:
```

```
3
```

```
Actual Array:
```

```
2 3
```

Test failed.

The length of a 2x3 array is 3.

```
verifyLength(testCase, [1 2 3; 4 5 6], 3);
```

Interactive verification passed.

Verify the length of a 2x3 array is not the number of elements, 6.

```
verifyLength(testCase, [1 2 3; 4 5 6], 6);
```

Interactive verification failed.

```

Framework Diagnostic:

```

```
verifyLength failed.
```

```
--> The array has an incorrect length.
```

```
Actual Length:
```

```
3
```

```
Expected Length:
```

```
6
```

```
Actual Array:
```

```
1 2 3
4 5 6
```

Test failed.

```
verifyLength(testCase, eye(2), 4);
```

Interactive verification failed.

```

Framework Diagnostic:

```

# matlab.unittest.qualifications.Verifiable.verifyLength

---

```
verifyLength failed.
--> The array has an incorrect length.
```

```
Actual Length:
 2
Expected Length:
 4
```

```
Actual Array:
 1 0
 0 1
```

## Test Cell Array Lengths

```
testCase = matlab.unittest.TestCase.forInteractiveUse;
verifyLength(testCase, {'somestring', 'someotherstring'}, 2);
```

```
Interactive verification passed.
```

## See Also

```
verifyThat | verifySize | verifyNumElements |
length | matlab.unittest.diagnostics.Diagnostic
| matlab.unittest.constraints.HasLength |
matlab.unittest.constraints | matlab.unittest.qualifications
```



# matlab.unittest.qualifications.Verifiable.verifyLessThan

## Purpose

Verify value is less than specified value

## Syntax

```
verifyLessThan(verifiable,actual,ceiling)
verifyLessThan(___,diagnostic)
```

## Description

`verifyLessThan(verifiable,actual,ceiling)` verifies that all elements of `actual` are less than all the elements of `ceiling`.

`verifyLessThan(___,diagnostic)` also displays the diagnostic information in `diagnostic` upon a failure.

## Tips

- This method is functionally equivalent to:

```
import matlab.unittest.constraints.IsLessThan;
verifiable.verifyThat(actual, IsLessThan(ceiling));
```

There exists more functionality when using the `IsLessThan` constraint directly via `verifyThat`.

## Input Arguments

### **verifiable**

The `matlab.unittest.TestCase` instance which is used to pass or fail the verification in conjunction with the test running framework.

### **actual**

The value to test. `actual` must be the same size as `ceiling` unless either one is scalar, at which point scalar expansion occurs.

### **ceiling**

Maximum value, exclusive.

### **diagnostic**

Diagnostic information to display upon a failure, specified as one of the following:

- string

# matlab.unittest.qualifications.Verifiable.verifyLessThan

---

- function handle
- matlab.unittest.diagnostics.Diagnostic object

Diagnostic values can be nonscalar. For more information, see `matlab.unittest.diagnostics.Diagnostic`.

## Examples

### Compare Two Numbers

Create a `TestCase` object for interactive testing.

```
testCase = matlab.unittest.TestCase.forInteractiveUse;
```

Verify 2 is less than 3.

```
verifyLessThan(testCase, 2, 3);
```

```
Interactive verification passed.
```

Test if 9 is less than 5.

```
verifyLessThan(testCase, 9, 5);
```

```
Interactive verification failed.
```

```

Framework Diagnostic:

```

```
verifyLessThan failed.
```

```
--> The value must be less than the maximum value.
```

```
Actual Value:
```

```
 9
```

```
Maximum Value (Exclusive):
```

```
 5
```

```
Test failed.
```

## Compare an Array to a Scalar

Test if each element is less than the CEILING value, 9.

```
testCase = matlab.unittest.TestCase.forInteractiveUse;
verifyLessThan(testCase, [5 6 7], 9);
```

```
Interactive verification passed.
```

Test if each element in the matrix is less than the CEILING value, 4.

```
verifyLessThan(testCase, [1 2 3; 4 5 6], 4);
```

```
Interactive verification failed.
```

```

Framework Diagnostic:

```

```
verifyLessThan failed.
```

```
--> Each element must be less than the maximum value.
```

```
Failing Indices:
```

```
 2 4 6
```

```
Actual Value:
```

```
 1 2 3
 4 5 6
```

```
Maximum Value (Exclusive):
```

```
 4
```

```
Test failed.
```

## Compare Arrays

Test if each element is less than each corresponding element of the CEILING array, [7 -1 8].

```
testCase = matlab.unittest.TestCase.forInteractiveUse;
verifyLessThan(testCase, [5 -3 2], [7 -1 8]);
```

# matlab.unittest.qualifications.Verifiable.verifyLessThan

---

Interactive verification passed.

Compare an array to itself.

```
verifyLessThan(testCase, eye(2), eye(2));
```

Interactive verification failed.

```

Framework Diagnostic:

```

verifyLessThan failed.

--> Each element must be less than each corresponding element of the maximum value.

Failing Indices:

```
 1 2 3 4
```

Actual Value:

```
 1 0
 0 1
```

Maximum Value (Exclusive):

```
 1 0
 0 1
```

Test failed.

## See Also

```
verifyThat | verifyLessThanOrEqual |
verifyGreaterThan | verifyGreaterThanOrEqual
| lt | matlab.unittest.constraints.IsLessThan
| matlab.unittest.diagnostics.Diagnostic |
matlab.unittest.constraints | matlab.unittest.qualifications
```

## Purpose

Verify value is less than or equal to specified value

## Syntax

```
verifyLessThanOrEqualTo(verifiable,actual,ceiling)
verifyLessThanOrEqualTo(___,diagnostic)
```

## Description

`verifyLessThanOrEqualTo(verifiable,actual,ceiling)` verifies that all elements of `actual` are less than or equal to all the elements of `ceiling`.

`verifyLessThanOrEqualTo(___,diagnostic)` also displays the diagnostic information in `diagnostic` upon a failure.

## Tips

- This method is functionally equivalent to:

```
import matlab.unittest.constraints.IsLessThanOrEqualTo;
verifiable.verifyThat(actual, IsLessThanOrEqualTo(ceiling));
```

There exists more functionality when using the `IsLessThanOrEqualTo` constraint directly via `verifyThat`.

## Input Arguments

### **verifiable**

The `matlab.unittest.TestCase` instance which is used to pass or fail the verification in conjunction with the test running framework.

### **actual**

The value to test.

### **ceiling**

Maximum value.

### **diagnostic**

Diagnostic information to display upon a failure, specified as one of the following:

- string

- function handle
- matlab.unittest.diagnostics.Diagnostic object

Diagnostic values can be nonscalar. For more information, see `matlab.unittest.diagnostics.Diagnostic`.

## Examples

### Compare Two Numbers

Create a `TestCase` object for interactive testing.

```
testCase = matlab.unittest.TestCase.forInteractiveUse;
```

Verify 2 is less than 3.

```
verifyLessThanOrEqual(testCase, 2, 3);
```

```
Interactive verification passed.
```

Verify 3 is less than or equal to 3.

```
verifyLessThanOrEqual(testCase, 3, 3);
```

```
Interactive verification passed.
```

Test if 9 is less than 5.

```
verifyLessThanOrEqual(testCase, 9, 5);
```

```
Interactive verification failed.
```

```

Framework Diagnostic:

```

```
verifyLessThanOrEqual failed.
```

```
--> The value must be less than or equal to the maximum value.
```

```
Actual Value:
```

```
 9
```

```
Maximum Value (Inclusive):
 5
```

Test failed.

## Compare an Array to a Scalar

Test if each element is less than or equal to the ceiling value, 7.

```
testCase = matlab.unittest.TestCase.forInteractiveUse;
verifyLessThanOrEqual(testCase, [5 2 7], 7);
```

```
Interactive verification passed.
```

Test if each element in the matrix is less than or equal to the ceiling value, 4.

```
verifyLessThanOrEqual(testCase, [1 2 3; 4 5 6], 4);
```

```
Interactive verification failed.
```

```

Framework Diagnostic:

```

```
verifyLessThanOrEqual failed.
--> Each element must be less than or equal to the maximum value.
```

```
Failing Indices:
 4 6
```

```
Actual Value:
```

```
 1 2 3
 4 5 6
```

```
Maximum Value (Inclusive):
 4
```

Test failed.

## Compare Arrays

Test if each element is less than or equal to each corresponding element of the ceiling array, [5 -3 8].

```
testCase = matlab.unittest.TestCase.forInteractiveUse;
verifyLessThanOrEqualTo(testCase, [5 -3 2], [5 -3 8]);
```

Interactive verification passed.

Compare an array to itself.

```
verifyLessThanOrEqualTo(testCase, eye(2), eye(2));
```

Interactive verification passed.

## See Also

```
verifyThat | verifyLessThan | verifyGreaterThan
| verifyGreaterThanOrEqual | le |
matlab.unittest.constraints.IsLessThanOrEqualTo
| matlab.unittest.diagnostics.Diagnostic |
matlab.unittest.constraints | matlab.unittest.qualifications
```



# matlab.unittest.qualifications.Verifiable.verifyMatches

## Purpose

Verify string matches specified regular expression

## Syntax

```
verifyMatches(verifiable,actual,expression)
verifyMatches(___,diagnostic)
```

## Description

`verifyMatches(verifiable,actual,expression)` that `actual` is a string that matches the regular expression defined by `expression`.

`verifyMatches(___,diagnostic)` also displays the diagnostic information in `diagnostic` upon a failure.

## Tips

- This method is functionally equivalent to:

```
import matlab.unittest.constraints.Matches;
verifiable.verifyThat(actual, Matches(expression));
```

There exists more functionality when using the `Matches` constraint directly via `verifyThat`.

## Input Arguments

### **verifiable**

The `matlab.unittest.TestCase` instance which is used to pass or fail the verification in conjunction with the test running framework.

### **actual**

The string to test.

### **expression**

The value to match, specified as a regular expression.

### **diagnostic**

Diagnostic information to display upon a failure, specified as one of the following:

- string
- function handle

# matlab.unittest.qualifications.Verifiable.verifyMatches

---

- matlab.unittest.diagnostics.Diagnostic object

Diagnostic values can be nonscalar. For more information, see `matlab.unittest.diagnostics.Diagnostic`.

## Examples

### Test for String Matches

Create a `TestCase` object for interactive testing.

```
testCase = matlab.unittest.TestCase.forInteractiveUse;
```

Verify that strings matches a regular expression.

```
verifyMatches(testCase, 'Some String', 'Some [Ss]tring', ...
 'My result should have matched the expression');
```

```
Interactive verification passed.
```

```
verifyMatches(testCase, 'Another string', '(Some |An)other');
```

```
Interactive verification passed.
```

```
verifyMatches(testCase, 'Another 3 strings', '^Another \d+ strings?$');
```

```
Interactive verification passed.
```

```
verifyMatches(testCase, '3 more strings', '\d+ strings?');
```

```
Interactive verification failed.
```

```

Framework Diagnostic:

```

```
verifyMatches failed.
```

```
--> The string did not match the regular expression.
```

```
Actual String:
```

```
 3 more strings
```

Regular Expression:  
`\d+ strings?`

Test failed.

## See Also

`verifyThat` | `verifySubstring` | `regexp` |  
`matlab.unittest.diagnostics.Diagnostic`  
| `matlab.unittest.constraints.Matches` |  
`matlab.unittest.constraints` | `matlab.unittest.qualifications`

# matlab.unittest.qualifications.Verifiable.verifyNotEmpty

<b>Purpose</b>	Verify value is not empty
<b>Syntax</b>	<pre>verifyNotEmpty(verifiable,actual) verifyNotEmpty( ____,diagnostic)</pre>
<b>Description</b>	<p><code>verifyNotEmpty(verifiable,actual)</code> verifies that <code>actual</code> is a non-empty MATLAB value.</p> <p><code>verifyNotEmpty( ____,diagnostic)</code> also displays the diagnostic information in <code>diagnostic</code> upon a failure.</p>
<b>Tips</b>	<ul style="list-style-type: none"><li>This method is functionally equivalent to: <pre>import matlab.unittest.constraints.IsEmpty; verifiable.verifyThat(actual, ~IsEmpty());</pre></li></ul> <p>There exists more functionality when using the <code>IsEmpty</code> constraint directly via <code>verifyThat</code>.</p>
<b>Input Arguments</b>	<p><b>verifiable</b></p> <p>The <code>matlab.unittest.TestCase</code> instance which is used to pass or fail the verification in conjunction with the test running framework.</p> <p><b>actual</b></p> <p>The value to test.</p> <p><b>diagnostic</b></p> <p>Diagnostic information to display upon a failure, specified as one of the following:</p> <ul style="list-style-type: none"><li>string</li><li>function handle</li><li><code>matlab.unittest.diagnostics.Diagnostic</code> object</li></ul>

Diagnostic values can be nonscalar. For more information, see `matlab.unittest.diagnostics.Diagnostic`.

## Examples

### Test for Non-Empty Strings

Create a `TestCase` object.

```
testCase = matlab.unittest.TestCase.forInteractiveUse;

verifyNotEmpty(testCase, '');
```

```
Interactive verification failed.
```

```

Framework Diagnostic:

verifyNotEmpty failed.
--> The value must not be empty.
--> The value has a size of [0 0].
```

```
Actual Value:
 ''
```

Test failed.

### Test for Non-Empty Arrays

An array with any zero dimension is empty.

Test array [2 3].

```
testCase = matlab.unittest.TestCase.forInteractiveUse;
verifyNotEmpty(testCase, [2 3]);
```

```
Interactive verification passed.
```

Test array with a zero dimension.

```
verifyNotEmpty(testCase, ones(2, 5, 0, 3));
```

# matlab.unittest.qualifications.Verifiable.verifyNotEmpty

---

```
Interactive verification failed.

Framework Diagnostic:

verifyNotEmpty failed.
--> The value must not be empty.
--> The value has a size of [2 5 0 3].

Actual Value:
 Empty array: 2-by-5-by-0-by-3
```

Test failed.

## Test for Non-Empty Cell Arrays

A cell array of empty arrays is not empty.

```
testCase = matlab.unittest.TestCase.forInteractiveUse;
verifyNotEmpty(testCase, {[], [], []}, '');
```

```
Interactive verification passed.
```

## Test for Non-Empty Test Suite

Test an empty object, emptyTestSuite.

```
emptyTestSuite = matlab.unittest.TestSuite.empty;
testCase = matlab.unittest.TestCase.forInteractiveUse;
verifyNotEmpty(testCase, emptyTestSuite);
```

```
Interactive verification failed.
```

```

Framework Diagnostic:

verifyNotEmpty failed.
--> The value must not be empty.
```

# matlab.unittest.qualifications.Verifiable.verifyNotEmpty

---

--> The value has a size of [0 0].

Actual Value:

0x0 TestCase array with no properties.

Test failed.

## See Also

[verifyThat](#) | [verifyEmpty](#) | [isempty](#) |  
[matlab.unittest.diagnostics.Diagnostic](#)  
| [matlab.unittest.constraints.IsEmpty](#) |  
[matlab.unittest.constraints.BooleanConstraint.not](#) |  
[matlab.unittest.constraints](#) | [matlab.unittest.qualifications](#)

# matlab.unittest.qualifications.Verifiable.verifyNotEqual

<b>Purpose</b>	Verify value is not equal to specified value
<b>Syntax</b>	<pre>verifyNotEqual(verifiable,actual,notExpected) verifyNotEqual( ____,diagnostic)</pre>
<b>Description</b>	<p><code>verifyNotEqual(verifiable,actual,notExpected)</code> verifies that <code>actual</code> is not equal to <code>notExpected</code>.</p> <p><code>verifyNotEqual( ____,diagnostic)</code> also displays the diagnostic information in <code>diagnostic</code> upon a failure.</p>
<b>Tips</b>	<ul style="list-style-type: none"><li>• This method is functionally equivalent to: <pre>import matlab.unittest.constraints.IsEqualTo; verifiable.verifyThat(actual, ~IsEqualTo(notExpected));</pre><p>There exists more functionality when using the <code>IsEqualTo</code> constraint directly via <code>verifyThat</code>.</p></li></ul>
<b>Input Arguments</b>	<p><b>verifiable</b> The <code>matlab.unittest.TestCase</code> instance which is used to pass or fail the verification in conjunction with the test running framework.</p> <p><b>actual</b> The value to test.</p> <p><b>notExpected</b> Value to compare.</p> <p><b>diagnostic</b> Diagnostic information to display upon a failure, specified as one of the following:</p> <ul style="list-style-type: none"><li>• string</li><li>• function handle</li></ul>



- matlab.unittest.diagnostics.Diagnostic object

Diagnostic values can be nonscalar. For more information, see `matlab.unittest.diagnostics.Diagnostic`.

## Examples

### Compare Numeric Values

Create a `TestCase` object for interactive testing.

```
testCase = matlab.unittest.TestCase.forInteractiveUse;
```

Compare a value to itself.

```
verifyNotEqual(testCase, 5, 5);
```

```
Interactive verification failed.
```

```

Framework Diagnostic:

verifyNotEqual failed.
--> NumericComparator passed.
```

```
Actual Value:
 5
Prohibited Value:
 5
```

Test failed.

Compare different number values.

```
verifyNotEqual(testCase, 4.95, 5, '4.95 should be different from 5');
```

```
Interactive verification passed.
```

Values 4.95 and 5 are not equal.

# matlab.unittest.qualifications.Verifiable.verifyNotEqual

---

Compare values of different sizes.

```
verifyNotEqual(testCase, [5 5], 5, '[5 5] is not equal to 5');
```

```
Interactive verification passed.
```

Values are not equal.

## Compare Classes

```
testCase = matlab.unittest.TestCase.forInteractiveUse;
verifyNotEqual(testCase, int8(5), int16(5), 'Classes dont match');
```

```
Interactive verification passed.
```

## Compare Cell Arrays

Test a cell array by comparing each element.

```
testCase = matlab.unittest.TestCase.forInteractiveUse;
verifyNotEqual(testCase, {'cell', struct, 5}, {'cell', struct, 5});
```

```
Interactive verification failed.
```

```

Framework Diagnostic:

verifyNotEqual failed.
--> CellComparator passed.
```

```
Actual Value:
 'cell' [1x1 struct] [5]
Prohibited Value:
 'cell' [1x1 struct] [5]
```

Test failed.

## See Also

[verifyThat](#) | [verifyEqual](#) |  
[matlab.unittest.diagnostics.Diagnostic](#) |

# matlab.unittest.qualifications.Verifiable.verifyNotEqual

---

```
matlab.unittest.constraints.IsEqualTo |
matlab.unittest.constraints.BooleanConstraint.not |
matlab.unittest.constraints | matlab.unittest.qualifications
```

# matlab.unittest.qualifications.Verifiable.verifyNotSameHandle

**Purpose** Verify value is not handle to specified instance

**Syntax** `verifyNotSameHandle(verifyable,actual,notExpectedHandle)`  
`verifyNotSameHandle( __ ,diagnostic)`

**Description** `verifyNotSameHandle(verifyable,actual,notExpectedHandle)` verifies that `actual` is a different size and/or does not contain the same instances as the `notExpectedHandle` handle array.

`verifyNotSameHandle( __ ,diagnostic)` also displays the diagnostic information in `diagnostic` upon a failure.

**Tips**

- This method is functionally equivalent to:

```
import matlab.unittest.constraints.IsSameHandleAs;
verifyable.verifyThat(actual, ~IsSameHandleAs(notExpectedHandle));
```

There exists more functionality when using the `IsSameHandleAs` constraint directly via `verifyThat`.

## Input Arguments

### **verifyable**

The `matlab.unittest.TestCase` instance which is used to pass or fail the verification in conjunction with the test running framework.

### **actual**

The value to test.

### **notExpectedHandle**

The handle array to compare.

### **diagnostic**

Diagnostic information to display upon a failure, specified as one of the following:

- string

- function handle
- matlab.unittest.diagnostics.Diagnostic object

Diagnostic values can be nonscalar. For more information, see `matlab.unittest.diagnostics.Diagnostic`.

## Examples

### Test Handles from Same Class

Create a `TestCase` object for interactive testing.

```
testCase = matlab.unittest.TestCase.forInteractiveUse;
```

Create a handle class, `ExampleHandle`.

```
classdef ExampleHandle < handle
end
```

Create two handle variables.

```
h1 = ExampleHandle;
h2 = ExampleHandle;
```

Handles point to different objects.

```
verifyNotSameHandle(testCase, h1, h2);
```

```
Interactive verification passed.
```

Show matching handle combinations.

```
verifyNotSameHandle(testCase, [h1 h2 h1], [h1 h2 h1]);
```

```
Interactive verification failed.
```

```

Framework Diagnostic:
```

```

verifyNotSameHandle failed.
```

# matlab.unittest.qualifications.Verifiable.verifyNotSameHandle

---

--> The two handles must not refer to the same handle, or should have different sizes.

Actual Value:

1x3 ExampleHandle array with no properties.

Handle Object:

1x3 ExampleHandle array with no properties.

Test failed.

The order of the handle arguments matters.

```
verifyNotSameHandle(testCase, [h1 h2], [h2 h1]);
```

Interactive verification passed.

Test a handle with itself.

```
verifyNotSameHandle(testCase, h1, h1);
```

Interactive verification failed.

-----  
Framework Diagnostic:  
-----

verifyNotSameHandle failed.

--> The two handles must not refer to the same handle, or should have different sizes.

Actual Value:

ExampleHandle with no properties.

Handle Object:

ExampleHandle with no properties.

Test failed.

Variables are not same size.

```
verifyNotSameHandle(testCase, h2, [h2 h2]);
```

```
Interactive verification passed.
```

```
Variables are the same size.
```

```
verifyNotSameHandle(testCase, [h1 h1], [h1 h1]);
```

```
Interactive verification failed.
```

```

Framework Diagnostic:

```

```
verifyNotSameHandle failed.
```

```
--> The two handles must not refer to the same handle, or should have
different sizes.
```

```
Actual Value:
```

```
 1x2 ExampleHandle array with no properties.
```

```
Handle Object:
```

```
 1x2 ExampleHandle array with no properties.
```

```
Test failed.
```

## See Also

```
verifySameHandle | verifyThat |
matlab.unittest.diagnostics.Diagnostic |
matlab.unittest.constraints.IsSameHandleAs |
matlab.unittest.constraints.BooleanConstraint.not |
matlab.unittest.constraints | matlab.unittest.qualifications
```

# matlab.unittest.qualifications.Verifiable.verifyNumElements

<b>Purpose</b>	Verify value has specified element count
<b>Syntax</b>	<pre>verifyNumElements(verifiable,actual,expectedElementCount) verifyNumElements(___,diagnostic)</pre>
<b>Description</b>	<p><code>verifyNumElements(verifiable,actual,expectedElementCount)</code> verifies that <code>actual</code> is a MATLAB array with <code>expectedElementCount</code> number of elements.</p> <p><code>verifyNumElements(___,diagnostic)</code> also displays the diagnostic information in <code>diagnostic</code> upon a failure.</p>

- Tips**
- This method is functionally equivalent to:  

```
import matlab.unittest.constraints.HasElementCount;
verifiable.verifyThat(actual, HasElementCount(expectedElementCount));
```

There exists more functionality when using the `HasElementCount` constraint directly via `verifyThat`.

<b>Input Arguments</b>	<p><b>verifiable</b></p> <p>The <code>matlab.unittest.TestCase</code> instance which is used to pass or fail the verification in conjunction with the test running framework.</p> <p><b>actual</b></p> <p>The value to test.</p> <p><b>expectedElementCount</b></p> <p>The expected number of elements in the array.</p> <p><b>diagnostic</b></p> <p>Diagnostic information to display upon a failure, specified as one of the following:</p> <ul style="list-style-type: none"><li>• string</li></ul>
------------------------	--------------------------------------------------------------------------------------------------------------------------------------------------------------------------------------------------------------------------------------------------------------------------------------------------------------------------------------------------------------------------------------------------------------------------------------------------------------------------------------------------------



- function handle
- matlab.unittest.diagnostics.Diagnostic object

Diagnostic values can be nonscalar. For more information, see `matlab.unittest.diagnostics.Diagnostic`.

## Examples

### Test Matrices

Create a `TestCase` object for interactive testing.

```
testCase = matlab.unittest.TestCase.forInteractiveUse;
```

```
n = 7;
verifyNumElements(testCase, eye(n), n^2);
```

```
Interactive verification passed.
```

```
verifyNumElements(testCase, 3, 1);
```

```
Interactive verification passed.
```

```
verifyNumElements(testCase, [1 2 3; 4 5 6], 5);
```

```
Interactive verification failed.
```

```

Framework Diagnostic:

```

```
verifyNumElements failed.
```

```
--> The value did not have the correct number of elements.
```

```
Actual Number of Elements:
```

```
6
```

```
Expected Number of Elements:
```

```
5
```

```
Actual Value:
```

# matlab.unittest.qualifications.Verifiable.verifyNumElements

---

```
1 2 3
4 5 6
```

Test failed.

## Test Cell Array

```
testCase = matlab.unittest.TestCase.forInteractiveUse;
verifyNumElements(testCase, {'SomeString', 'SomeOtherString'}, 2);
```

Interactive verification passed.

## Test Structure

```
s.Field1 = 1;
s.Field2 = 2;
testCase = matlab.unittest.TestCase.forInteractiveUse;
verifyNumElements(testCase, s, 2);
```

Interactive verification failed.

```

Framework Diagnostic:

```

```
verifyNumElements failed.
```

```
--> The value did not have the correct number of elements.
```

```
Actual Number of Elements:
```

```
1
```

```
Expected Number of Elements:
```

```
2
```

```
Actual Value:
```

```
Field1: 1
```

```
Field2: 2
```

Test failed.

## See Also

[verifyThat](#) | [verifySize](#) | [verifyLength](#) | [numel](#)  
| [matlab.unittest.diagnostics.Diagnostic](#) |  
[matlab.unittest.constraints.HasElementCount](#) |  
[matlab.unittest.constraints](#) | [matlab.unittest.qualifications](#)

# matlab.unittest.qualifications.Verifiable.verifyReturnsTrue

**Purpose** Verify function returns true when evaluated

**Syntax** `verifyReturnsTrue(verifiable,actual)`  
`verifyReturnsTrue(___,diagnostic)`

**Description** `verifyReturnsTrue(verifiable,actual)` verifies that `actual` is a function handle that returns a scalar logical whose value is true.  
`verifyReturnsTrue(___,diagnostic)` also displays the diagnostic information in `diagnostic` upon a failure.

**Tips**

- It is a shortcut for quick custom comparison functionality that can be defined quickly, and possibly inline. It can be preferable over simply evaluating the function directly and using `verifyTrue` because the function handle will be shown in the diagnostics, thus providing more insight into the failure condition which is lost when using `verifyTrue`.
- This method is functionally equivalent to:

```
import matlab.unittest.constraints.ReturnsTrue;
verifiable.verifyThat(actual, ReturnsTrue());
```

There exists more functionality when using the `ReturnsTrue` constraint directly via `verifyThat`.

## Input Arguments

### **verifiable**

The `matlab.unittest.TestCase` instance which is used to pass or fail the verification in conjunction with the test running framework.

### **actual**

The function handle to test.

### **diagnostic**

Diagnostic information to display upon a failure, specified as one of the following:

- string
- function handle
- matlab.unittest.diagnostics.Diagnostic object

Diagnostic values can be nonscalar. For more information, see `matlab.unittest.diagnostics.Diagnostic`.

## Examples

### Test if Condition is True

Create a `TestCase` object for interactive testing.

```
testCase = matlab.unittest.TestCase.forInteractiveUse;
verifyReturnsTrue(testCase, @true);
```

```
Interactive verification passed.
```

Verify that it is true that two numbers are equal.

```
verifyReturnsTrue(testCase, @() isequal(1,1));
```

```
Interactive verification passed.
```

Verify that it is true that two letters are not the same.

```
verifyReturnsTrue(testCase, @() ~strcmp('a','b'));
```

```
Interactive verification passed.
```

Cause verification to fail by trying to verify that “false” evaluates to “true”.

```
verifyReturnsTrue(testCase, @false);
```

```
Interactive verification failed.
```

```

Framework Diagnostic:
```

# matlab.unittest.qualifications.Verifiable.verifyReturnsTrue

---

```

verifyReturnsTrue failed.
--> The function handle should have evaluated to "true".
--> Returned value:
 0
```

```
Actual Function Handle:
 @false
```

Test failed.

Cause verification to fail by having the test specified in the function handle return a vector of logical values not a scalar logical value.

```
verifyReturnsTrue(testCase, @() strcmp('a',{ 'a','a'}));
```

Interactive verification failed.

```

Framework Diagnostic:

verifyReturnsTrue failed.
--> The function handle should have returned a scalar. The return value h
--> Returned value:
 1 1
```

```
Actual Function Handle:
 @()strcmp('a',{ 'a','a'})
```

Test failed.

Cause verification to fail by having the test specified in the function handle return a double not a logical.

```
verifyReturnsTrue(testCase, @() exist('exist'));
```

Interactive verification failed.

```

Framework Diagnostic:

verifyReturnsTrue failed.
--> The function handle should have returned a logical value. It was c
--> Returned value:
 5
```

```
Actual Function Handle:
 @()exist('exist')
```

Test failed.

## See Also

```
verifyThat | verifyTrue |
matlab.unittest.diagnostics.Diagnostic |
matlab.unittest.constraints.ReturnsTrue |
matlab.unittest.constraints | matlab.unittest.qualifications
```

# matlab.unittest.qualifications.Verifiable.verifySameHandle

**Purpose** Verify two values are handles to same instance

**Syntax** `verifySameHandle(verifiable,actual,expectedHandle)`  
`verifySameHandle(___,diagnostic)`

**Description** `verifySameHandle(verifiable,actual,expectedHandle)` verifies that `actual` is the same size and contains the same instances as the `expectedHandle` handle array.

`verifySameHandle(___,diagnostic)` also displays the diagnostic information in `diagnostic` upon a failure.

**Tips**

- This method is functionally equivalent to:

```
import matlab.unittest.constraints.IsSameHandleAs;
verifiable.verifyThat(actual, IsSameHandleAs(expectedHandle));
```

There exists more functionality when using the `IsSameHandleAs` constraint directly via `verifyThat`.

## Input Arguments

### **verifiable**

The `matlab.unittest.TestCase` instance which is used to pass or fail the verification in conjunction with the test running framework.

### **actual**

The value to test.

### **expectedHandle**

The expected handle array.

### **diagnostic**

Diagnostic information to display upon a failure, specified as one of the following:

- string



- function handle
- matlab.unittest.diagnostics.Diagnostic object

Diagnostic values can be nonscalar. For more information, see `matlab.unittest.diagnostics.Diagnostic`.

## Examples

### Test Handles from Same Class

Create a `TestCase` object for interactive testing.

```
testCase = matlab.unittest.TestCase.forInteractiveUse;
```

Create a handle class, `ExampleHandle`.

```
classdef ExampleHandle < handle
end
```

Create two handle variables.

```
h1 = ExampleHandle;
h2 = ExampleHandle;
```

Show matching handle combinations.

```
verifySameHandle(testCase, h1, h1);
```

```
Interactive verification passed.
```

```
verifySameHandle(testCase, [h1 h1], [h1 h1]);
```

```
Interactive verification passed.
```

```
verifySameHandle(testCase, [h1 h2 h1], [h1 h2 h1]);
```

```
Interactive verification passed.
```

Handles must point to same object.

# matlab.unittest.qualifications.Verifiable.verifySameHandle

---

```
verifySameHandle(testCase, h1, h2);
```

```
Interactive verification failed.
```

```

Framework Diagnostic:

```

```
verifySameHandle failed.
--> Values do not refer to the same handle.
```

```
Actual Value:
 ExampleHandle with no properties.
Expected Handle Object:
 ExampleHandle with no properties.
```

Test failed.

Size of handle objects must match.

```
verifySameHandle(testCase, [h1 h1], h1);
```

```
Interactive verification failed.
```

```

Framework Diagnostic:

```

```
verifySameHandle failed.
--> Sizes do not match.
 Actual Value Size : [1 2]
 Expected Handle Object Size : [1 1]
```

```
Actual Value:
 1x2 ExampleHandle array with no properties.
Expected Handle Object:
 ExampleHandle with no properties.
```

Test failed.

Order of arguments is important.

```
verifySameHandle(testCase, [h1 h2], [h2 h1]);
```

Interactive verification failed.

```

Framework Diagnostic:

```

```
verifySameHandle failed.
```

```
--> Some elements in the handle array refer to the wrong handle.
```

Actual Value:

```
 1x2 ExampleHandle array with no properties.
```

Expected Handle Object:

```
 1x2 ExampleHandle array with no properties.
```

Test failed.

## See Also

[verifyThat](#) | [verifyNotSameHandle](#) | [handle](#)  
| [matlab.unittest.diagnostics.Diagnostic](#) |  
[matlab.unittest.constraints.IsSameHandleAs](#) |  
[matlab.unittest.constraints](#) | [matlab.unittest.qualifications](#)

# matlab.unittest.qualifications.Verifiable.verifySize

---

<b>Purpose</b>	Verify value has specified size
<b>Syntax</b>	<code>verifySize(verifiable,actual,expectedSize)</code> <code>verifySize( __ ,diagnostic)</code>
<b>Description</b>	<code>verifySize(verifiable,actual,expectedSize)</code> verifies that <code>actual</code> is a MATLAB array whose size is <code>expectedSize</code> . <code>verifySize( __ ,diagnostic)</code> also displays the diagnostic information in <code>diagnostic</code> upon a failure.
<b>Tips</b>	<ul style="list-style-type: none"><li>This method is functionally equivalent to: <pre>import matlab.unittest.constraints.HasSize; verifiable.verifyThat(actual, HasSize(expectedSize));</pre> There exists more functionality when using the <code>HasSize</code> constraint directly via <code>verifyThat</code>.</li></ul>
<b>Input Arguments</b>	<p><b>verifiable</b> The <code>matlab.unittest.TestCase</code> instance which is used to pass or fail the verification in conjunction with the test running framework.</p> <p><b>actual</b> The value to test.</p> <p><b>expectedSize</b> The expected sizes of each dimension the array.</p> <p><b>diagnostic</b> Diagnostic information to display upon a failure, specified as one of the following:</p> <ul style="list-style-type: none"><li>string</li><li>function handle</li></ul>

- matlab.unittest.diagnostics.Diagnostic object

Diagnostic values can be nonscalar. For more information, see `matlab.unittest.diagnostics.Diagnostic`.

## Examples

### Test Arrays

Create a `TestCase` object for interactive testing.

```
testCase = matlab.unittest.TestCase.forInteractiveUse;
```

```
verifySize(testCase, ones(2, 5, 3), [2 5 3]);
```

```
Interactive verification passed.
```

```
verifySize(testCase, [1 2 3; 4 5 6], [2 3]);
```

```
Interactive verification passed.
```

```
verifySize(testCase, [2 3], [3 2]);
```

```
Interactive verification failed.
```

```

Framework Diagnostic:

```

```
verifySize failed.
```

```
--> The value had an incorrect size.
```

```
Actual Size:
```

```
1 2
```

```
Expected Size:
```

```
3 2
```

```
Actual Value:
```

```
2 3
```

```
Test failed.
```

# matlab.unittest.qualifications.Verifiable.verifySize

---

Number of elements is not the same as size.

```
verifySize(testCase, [1 2 3; 4 5 6], [6 1]);
```

Interactive verification failed.

```

Framework Diagnostic:

```

```
verifySize failed.
```

```
--> The value had an incorrect size.
```

```
Actual Size:
```

```
 2 3
```

```
Expected Size:
```

```
 6 1
```

```
Actual Value:
```

```
 1 2 3
```

```
 4 5 6
```

Test failed.

```
verifySize(testCase, eye(2), [4 1]);
```

Interactive verification failed.

```

Framework Diagnostic:

```

```
verifySize failed.
```

```
--> The value had an incorrect size.
```

```
Actual Size:
```

```
 2 2
```

```
Expected Size:
```

```
 4 1
```

Actual Value:

```
 1 0
 0 1
```

Test failed.

## Test Cell Array

```
testCase = matlab.unittest.TestCase.forInteractiveUse;
verifySize(testCase, {'SomeString', 'SomeOtherString'}, [1 2]);
```

Interactive verification passed.

## See Also

[verifyThat](#) | [verifyLength](#) | [verifyNumElements](#) | [size](#) | [matlab.unittest.diagnostics.Diagnostic](#) | [matlab.unittest.constraints.HasSize](#) | [matlab.unittest.constraints](#) | [matlab.unittest.qualifications](#)

# matlab.unittest.qualifications.Verifiable.verifySubstring

<b>Purpose</b>	Verify string contains specified string
<b>Syntax</b>	<pre>verifySubstring(verifiable,actual,substring) verifySubstring(___,diagnostic)</pre>
<b>Description</b>	<p><code>verifySubstring(verifiable,actual,substring)</code> verifies that <code>actual</code> is a string that contains <code>substring</code>.</p> <p><code>verifySubstring(___,diagnostic)</code> also displays the diagnostic information in <code>diagnostic</code> upon a failure.</p>
<b>Tips</b>	<ul style="list-style-type: none"><li>This method is functionally equivalent to: <pre>import matlab.unittest.constraints.ContainsSubstring; verifiable.verifyThat(actual, ContainsSubstring(substring));</pre><p>There exists more functionality when using the <code>ContainsSubstring</code> constraint directly via <code>verifyThat</code>.</p></li></ul>
<b>Input Arguments</b>	<p><b>verifiable</b></p> <p>The <code>matlab.unittest.TestCase</code> instance which is used to pass or fail the verification in conjunction with the test running framework.</p> <p><b>actual</b></p> <p>The string to test.</p> <p><b>substring</b></p> <p>The value to match, specified as a string.</p> <p><b>diagnostic</b></p> <p>Diagnostic information to display upon a failure, specified as one of the following:</p> <ul style="list-style-type: none"><li>string</li><li>function handle</li></ul>



# matlab.unittest.qualifications.Verifiable.verifySubstring

---

- matlab.unittest.diagnostics.Diagnostic object

Diagnostic values can be nonscalar. For more information, see `matlab.unittest.diagnostics.Diagnostic`.

## Examples

### Test for Substrings

Create a `TestCase` object for interactive testing.

```
testCase = matlab.unittest.TestCase.forInteractiveUse;
```

Test that a substring is contained in a string.

```
verifySubstring(testCase, 'SomeLongString', 'Long');
```

```
Interactive verification passed.
```

Show that case matters.

```
verifySubstring(testCase, 'SomeLongString', 'lonG');
```

```
Interactive verification failed.
```

```

Framework Diagnostic:

verifySubstring failed.
--> The string must contain the substring.
```

```
Actual String:
 SomeLongString
Expected Substring:
 lonG
```

Test failed.

Cause the verification to fail by testing a substring that isn't contained in the actual string.

# matlab.unittest.qualifications.Verifiable.verifySubstring

---

```
verifySubstring(testCase, 'SomeLongString', 'OtherString');
```

```
Interactive verification failed.
```

```

Framework Diagnostic:
```

```

```

```
verifySubstring failed.
```

```
--> The string must contain the substring.
```

```
Actual String:
```

```
 SomeLongString
```

```
Expected Substring:
```

```
 OtherString
```

```
Test failed.
```

Show that the verification will fail if the substring is longer than the actual string.

```
verifySubstring(testCase, 'SomeLongString', 'SomeLongStringThatIsLonger')
```

```
Interactive verification failed.
```

```

Framework Diagnostic:
```

```

```

```
verifySubstring failed.
```

```
--> The string must contain the substring.
```

```
Actual String:
```

```
 SomeLongString
```

```
Expected Substring:
```

```
 SomeLongStringThatIsLonger
```

```
Test failed.
```

# matlab.unittest.qualifications.Verifiable.verifySubstring

---

## See Also

`verifyThat` | `verifyMatches` | `strfind` |  
`matlab.unittest.diagnostics.Diagnostic` |  
`matlab.unittest.constraints.ContainsSubstring` |  
`matlab.unittest.constraints` | `matlab.unittest.qualifications`

# matlab.unittest.qualifications.Verifiable.verifyThat

---

**Purpose** Verify value meets given constraint

**Syntax** `verifyThat(verifiable,actual,constraint)`  
`verifyThat( __ ,diagnostic)`

**Description** `verifyThat(verifiable,actual,constraint)` verifies that `actual` is a value that satisfies the `constraint` provided.

If the constraint is not satisfied, a verification failure is produced utilizing only the framework diagnostic generated by the `constraint`.

`verifyThat( __ ,diagnostic)` also displays the diagnostic information in `diagnostic` upon a failure.

When using this signature, both the diagnostic information contained within `diagnostic` is used in addition to the diagnostic information provided by the `constraint`.

## Input Arguments

### **verifiable**

The `matlab.unittest.TestCase` instance which is used to pass or fail the verification in conjunction with the test running framework.

### **actual**

The value to test.

### **constraint**

### **diagnostic**

Diagnostic information to display upon a failure, specified as one of the following:

- string
- function handle
- `matlab.unittest.diagnostics.Diagnostic` object

Diagnostic values can be nonscalar. For more information, see `matlab.unittest.diagnostics.Diagnostic`.

## Examples **Test Conditions Using Constraints**

```
testCase = matlab.unittest.TestCase.forInteractiveUse;

% Passing scenarios
%%
import matlab.unittest.constraints.IsTrue;
verifyThat(testCase, true, IsTrue);

import matlab.unittest.constraints.IsEqualTo;
verifyThat(testCase, 5, IsEqualTo(5), '5 should be equal to 5');

import matlab.unittest.constraints.IsGreaterThan;
import matlab.unittest.constraints.HasNaN;
verifyThat(testCase, [5 NaN], IsGreaterThan(10) | HasNaN, ...
 'The value was not greater than 10 or NaN');

% Failing scenarios
%%
import matlab.unittest.constraints.AnyCellof;
import matlab.unittest.constraints.ContainsSubstring;
verifyThat(testCase, AnyCellof({'cell', 'of', 'strings'}), ...
 ContainsSubstring('char'), 'Test description');

import matlab.unittest.constraints.HasSize;
verifyThat(testCase, zeros(10,4,2), HasSize([10,5,2]), ...
 @() disp('A function handle diagnostic.'));

import matlab.unittest.constraints.IsEmpty;
verifyThat(testCase, 5, IsEmpty);
```

# matlab.unittest.qualifications.Verifiable.verifyThat

---

## See Also

[matlab.unittest.diagnostics.Diagnostic](#) |  
[matlab.unittest.constraints.Constraint](#) |  
[matlab.unittest.constraints](#) | [matlab.unittest.qualifications](#)

# matlab.unittest.qualifications.Verifiable.verifyTrue

---

## Purpose

Verify value is true

## Syntax

```
verifyTrue(verifiable,actual)
verifyTrue(__,diagnostic)
```

## Description

`verifyTrue(verifiable,actual)` verifies that `actual` is a scalar logical with the value of true.

`verifyTrue(__,diagnostic)` also displays the diagnostic information in `diagnostic` upon a failure.

## Tips

- This method passes if and only if the actual value is a scalar logical with a value of true. Therefore, entities such as true valued arrays and nonzero doubles produce qualification failures when used in this method, despite these entities exhibiting "true-like" behavior such as triggering the execution of code inside of "if" statements.
- This method is functionally equivalent to:

```
import matlab.unittest.constraints.IsTrue;
verifiable.verifyThat(actual, IsTrue());
```

There exists more functionality when using the `IsTrue` constraint directly via `verifyThat`.

Use of this method for performance benefits can come at the expense of less diagnostic information, and may not provide the same level of strictness adhered to by other constraints such as `IsEqualTo`. A similar approach that is generally less performant but can provide slightly better diagnostic information is the use of `verifyReturnsTrue`, which at least shows the display of the function evaluated to generate the failing result.

## Input Arguments

### **verifiable**

The `matlab.unittest.TestCase` instance which is used to pass or fail the verification in conjunction with the test running framework.

# matlab.unittest.qualifications.Verifiable.verifyTrue

---

## **actual**

The value to test.

## **diagnostic**

Diagnostic information to display upon a failure, specified as one of the following:

- string
- function handle
- matlab.unittest.diagnostics.Diagnostic object

Diagnostic values can be nonscalar. For more information, see `matlab.unittest.diagnostics.Diagnostic`.

## **Examples**

### **Test MATLAB Logical Functions**

Create a `TestCase` object for interactive testing.

```
testCase = matlab.unittest.TestCase.forInteractiveUse;
```

Test true.

```
verifyTrue(testCase, true);
```

```
Interactive verification passed.
```

Test false.

```
verifyTrue(testCase, false);
```

```
Interactive verification failed.
```

```

Framework Diagnostic:

verifyTrue failed.
```



```
--> The value must evaluate to "true".
```

```
Actual Value:
```

```
 0
```

```
Test failed.
```

## Test the Value 1

```
The number 1 is a double value, not a logical value.
```

```
A double value of 1 is not true.
```

```
testCase = matlab.unittest.TestCase.forInteractiveUse;
verifyTrue(testCase, 1);
```

```
Interactive verification failed.
```

```

Framework Diagnostic:
```

```

verifyTrue failed.
```

```
--> The value must be logical. It is of type "double".
```

```
Actual Value:
```

```
 1
```

```
Test failed.
```

## Test Array of Logical Values

```
To be true, the value must be scalar.
```

```
testCase = matlab.unittest.TestCase.forInteractiveUse;
verifyTrue(testCase, [true true true]);
```

```
Interactive verification failed.
```

```

Framework Diagnostic:
```

# matlab.unittest.qualifications.Verifiable.verifyTrue

---

```

verifyTrue failed.
--> The value must be scalar. It has a size of [1 3].
```

```
Actual Value:
 1 1 1
```

Test failed.

Optimized comparison that trades speed for less diagnostics.

```
verifyTrue(testCase, ~isempty(strfind('string', 'ring')), ...
 'Could not find expected string');
```

## See Also

```
verifyThat | verifyFalse | verifyReturnsTrue
| matlab.unittest.diagnostics.Diagnostic
| matlab.unittest.constraints.IsTrue |
matlab.unittest.constraints | matlab.unittest.qualifications
```

# matlab.unittest.qualifications.Verifiable.verifyWarning

<b>Purpose</b>	Verify function issues specified warning
<b>Syntax</b>	<pre>verifyWarning(verifiable,actual,warningID) verifyWarning( ____,diagnostic) [output1,...,outputN] = verifyWarning( ____ )</pre>
<b>Description</b>	<p><code>verifyWarning(verifiable,actual,warningID)</code> verifies that <code>actual</code> issues a warning with the identifier <code>warningID</code>.</p> <p><code>verifyWarning( ____,diagnostic)</code> also displays the diagnostic information in <code>diagnostic</code> upon a failure.</p> <p><code>[output1,...,outputN] = verifyWarning( ____ )</code> also returns the output arguments <code>output1,...,outputN</code> that are produced when invoking <code>actual</code>.</p>
<b>Tips</b>	<ul style="list-style-type: none"><li>This method is functionally equivalent to:<pre>import matlab.unittest.constraints.IssuesWarnings; verifiable.verifyThat(actual, IssuesWarnings({warningID}));</pre>There exists more functionality when using the <code>IssuesWarnings</code> constraint directly via <code>verifyThat</code>.</li></ul>
<b>Input Arguments</b>	<p><b>verifiable</b></p> <p>The <code>matlab.unittest.TestCase</code> instance which is used to pass or fail the verification in conjunction with the test running framework.</p> <p><b>actual</b></p> <p>The function handle to test.</p> <p><b>warningID</b></p> <p>Warning ID, specified as a string.</p> <p><b>diagnostic</b></p>

# matlab.unittest.qualifications.Verifiable.verifyWarning

Diagnostic information to display upon a failure, specified as one of the following:

- string
- function handle
- matlab.unittest.diagnostics.Diagnostic object

Diagnostic values can be nonscalar. For more information, see `matlab.unittest.diagnostics.Diagnostic`.

## Output Arguments

### `output1,...,outputN`

Output arguments, 1 through n (if any), from `actual`, returned as any type. The argument type is specified by the `actual` argument list.

## Examples

### Test warning Function

Create a `TestCase` object for interactive testing.

```
testCase = matlab.unittest.TestCase.forInteractiveUse;
```

Verify `actual` warning ID is the same as input warning ID.

```
verifyWarning(testCase, @() warning('SOME:warning:id','Warning!'), ...
 'SOME:warning:id');
```

```
Interactive verification passed.
```

```
verifyWarning(testCase, @() warning('SOME:other:id', 'Warning message'), ...
 'SOME:warning:id', 'Did not issue specified warning');
```

```
Warning: Warning message
```

```
> In @()warning('SOME:other:id','Warning message')
 In FunctionHandleConstraint>FunctionHandleConstraint.invoke at 43
 In WarningQualificationConstraint>WarningQualificationConstraint.invoke
 In IssuesWarnings>IssuesWarnings.invoke at 364
```

# matlab.unittest.qualifications.Verifiable.verifyWarning

---

```
In IssuesWarnings>IssuesWarnings.issuesExpectedWarnings at 411
In IssuesWarnings>IssuesWarnings.satisfiedBy at 240
In QualificationDelegate>QualificationDelegate.qualifyThat at 90
In QualificationDelegate>QualificationDelegate.qualifyWarning at 190
In Verifiable>Verifiable.verifyWarning at 701
Interactive verification failed.
```

```

Test Diagnostic:

Did not issue specified warning
```

```

Framework Diagnostic:

verifyWarning failed.
--> The function handle did not issue a correct warning profile.
 The expected warning profile ignores:
 Set
 Count
 Order
--> The function handle did not issue the correct warnings.
```

```
Missing Warnings:
 SOME:warning:id
```

```
Actual Warning Profile:
 SOME:other:id
Expected Warning Profile:
 SOME:warning:id
```

```
Evaluated Function:
 @()warning('SOME:other:id','Warning message')
```

## Test a Function Without Warnings

Test the true function, which does not issue warnings.

# matlab.unittest.qualifications.Verifiable.verifyWarning

---

```
testCase = matlab.unittest.TestCase.forInteractiveUse;
verifyWarning(testCase, @true, 'SOME:warning:id', ...
 '@true did not issue any warning');

Interactive verification failed.

Test Diagnostic:

@true did not issue any warning

Framework Diagnostic:

verifyWarning failed.
--> The function handle did not issue a correct warning profile.
 The expected warning profile ignores:
 Set
 Count
 Order
--> The function handle did not issue any warnings.

Expected Warning Profile:
 SOME:warning:id

Evaluated Function:
 @true

Test failed.
```

## Test Function With Output Arguments

Create a helper function that generates a warning and returns output.

```
function varargout = helper()
 warning('SOME:warning:id', 'Warning!');
 varargout = {123, 'abc'};
end
```

# matlab.unittest.qualifications.Verifiable.verifyWarning

---

Call helper.

```
testCase = matlab.unittest.TestCase.forInteractiveUse;
[actualOut1, actualOut2] = verifyWarning(testCase, @helper, ...
 'SOME:warning:id');
```

Interactive verification passed.

## See Also

[verifyThat](#) | [verifyError](#) | [verifyWarningFree](#) |  
[warning](#) | [matlab.unittest.diagnostics.Diagnostic](#)  
| [matlab.unittest.constraints.IssuesWarnings](#) |  
[matlab.unittest.constraints](#) | [matlab.unittest.qualifications](#)

# matlab.unittest.qualifications.Verifiable.verifyWarningFree

<b>Purpose</b>	Verify function issues no warnings
<b>Syntax</b>	<pre>verifyWarningFree(verifiable,actual) verifyWarningFree(___,diagnostic) output1,...,outputN = verifyWarningFree(___)</pre>
<b>Description</b>	<p><code>verifyWarningFree(verifiable,actual)</code> verifies that <code>actual</code> is a function handle that issues no warnings.</p> <p><code>verifyWarningFree(___,diagnostic)</code> also displays the diagnostic information in <code>diagnostic</code> upon a failure.</p> <p><code>output1,...,outputN = verifyWarningFree(___)</code> also returns the output arguments <code>output1,...,outputN</code> that are produced when invoking <code>actual</code>.</p>
<b>Tips</b>	<ul style="list-style-type: none"><li>• This method is functionally equivalent to: <pre>import matlab.unittest.constraints.IssuesNoWarnings; verifiable.verifyThat(actual, IssuesNoWarnings());</pre><p>There exists more functionality when using the <code>IssuesNoWarnings</code> constraint directly via <code>verifyThat</code>.</p></li></ul>
<b>Input Arguments</b>	<p><b>verifiable</b></p> <p>The <code>matlab.unittest.TestCase</code> instance which is used to pass or fail the verification in conjunction with the test running framework.</p> <p><b>actual</b></p> <p>The function handle to test.</p> <p><b>diagnostic</b></p> <p>Diagnostic information to display upon a failure, specified as one of the following:</p> <ul style="list-style-type: none"><li>• string</li></ul>



- function handle
- matlab.unittest.diagnostics.Diagnostic object

Diagnostic values can be nonscalar. For more information, see `matlab.unittest.diagnostics.Diagnostic`.

## Output Arguments

### **output1,...,outputN**

Output arguments, 1 through n (if any), from `actual`, returned as any type. The argument type is specified by the `actual` argument list.

## Examples

### **Test for Warnings from MATLAB Functions**

Create a `TestCase` object for interactive testing.

```
testCase = matlab.unittest.TestCase.forInteractiveUse;
```

Test the `why` function.

```
verifyWarningFree(testCase, @why);
```

```
The bald and not excessively bald and not excessively smart hamster of
Interactive verification passed.
```

This is a randomly-generated message.

Test the `true` function.

```
verifyWarningFree(testCase, @true);
```

```
Interactive verification passed.
```

Test the `false` function.

```
actualOutputFromFalse = verifyWarningFree(testCase, @false);
```

```
Interactive verification passed.
```

# matlab.unittest.qualifications.Verifiable.verifyWarningFree

Test a value that is not a function handle.

```
verifyWarningFree(testCase, 5, 'diagnostic');
```

Interactive verification failed.

```

Test Diagnostic:

```

```
diagnostic
```

```

Framework Diagnostic:

```

```
verifyWarningFree failed.
```

```
--> The value must be an instance of the expected type.
```

```
 Actual Class:
```

```
 double
```

```
 Expected Type:
```

```
 function_handle
```

```
Actual Value:
```

```
 5
```

Test failed.

Test a function that generates warning.

```
verifyWarningFree(testCase, @() warning('some:id', 'Message'));
```

```
Warning: Message
```

```
> In @()warning('some:id','Message')
```

```
 In FunctionHandleConstraint>FunctionHandleConstraint.invoke at 43
```

```
 In WarningQualificationConstraint>WarningQualificationConstraint.invoke
```

```
 In IssuesNoWarnings>IssuesNoWarnings.issuesNoWarnings at 131
```

```
 In IssuesNoWarnings>IssuesNoWarnings.satisfiedBy at 82
```

```
 In QualificationDelegate>QualificationDelegate.qualifyThat at 90
```

# matlab.unittest.qualifications.Verifiable.verifyWarningFree

---

```
In QualificationDelegate>QualificationDelegate.qualifyWarningFree at
In Verifiable>Verifiable.verifyWarningFree at 757
Interactive verification failed.
```

```

Framework Diagnostic:

verifyWarningFree failed.
--> The function issued warnings.
```

```
Warnings Issued:
 some:id
```

```
Evaluated Function:
 @()warning('some:id', 'Message')
```

Test failed.

## See Also

[verifyThat](#) | [verifyWarning](#) | [warning](#) |  
[matlab.unittest.diagnostics.Diagnostic](#) |  
[matlab.unittest.constraints.IssuesNoWarnings](#) |  
[matlab.unittest.constraints](#) | [matlab.unittest.qualifications](#)

# questdlg

---

**Purpose** Create and open question dialog box

**Syntax**

```
button = questdlg('qstring')
button = questdlg('qstring','title')
button = questdlg('qstring','title',default)
button = questdlg('qstring','title','str1','str2',default)
button =
questdlg('qstring','title','str1','str2','str3',default)
button = questdlg('qstring','title', ..., options)
```

**Description** `button = questdlg('qstring')` displays a modal dialog box presenting the question 'qstring'. The dialog has three default buttons, **Yes**, **No**, and **Cancel**. If the user presses one of these three buttons, `button` is set to the name of the button pressed. If the user presses the close button on the dialog without making a choice, `button` is set to the empty string. If the user presses the **Return** key, `button` is set to 'Yes'. 'qstring' is a cell array or a string that automatically wraps to fit within the dialog box.

---

**Note** A modal dialog box prevents the user from interacting with other windows before responding. For more information, see `WindowState` in the MATLAB Figure Properties.

---

`button = questdlg('qstring','title')` displays a question dialog with 'title' displayed in the dialog's title bar.

`button = questdlg('qstring','title',default)` specifies which push button is the default in the event that the **Return** key is pressed. '*default*' must be 'Yes', 'No', or 'Cancel'.

`button = questdlg('qstring','title','str1','str2',default)` creates a question dialog box with two push buttons labeled 'str1' and 'str2'. *default* specifies the default button selection and must be 'str1' or 'str2'.

```
button =
questdlg('qstring','title','str1','str2','str3',default)
creates a question dialog box with three push buttons labeled 'str1',
'str2', and 'str3'. default specifies the default button selection and
must be 'str1', 'str2', or 'str3'.
```

When *default* is specified, but is not set to one of the button names, pressing the **Enter** key displays a warning and the dialog remains open.

```
button = questdlg('qstring','title', ..., options) replaces
the string default with a structure, options. The structure specifies
which button string is the default answer, and whether to use TeX to
interpret the question string, qstring. Button strings and dialog titles
cannot use TeX interpretation. The options structure must include the
fields Default and Interpreter, both strings. It can include other
fields, but questdlg does not use them. You can set Interpreter to
'none' or 'tex'. If the Default field does not contain a valid button
name, a command window warning is issued and the dialog box does
not respond to pressing the Enter key.
```

## Examples

### Example 1

Create a dialog that requests a dessert preference and encode the resulting choice as an integer.

```
% Construct a questdlg with three options
choice = questdlg('Would you like a dessert?', ...
'Dessert Menu', ...
'Ice cream','Cake','No thank you','No thank you');
% Handle response
switch choice
case 'Ice cream'
 disp([choice ' coming right up.'])
 dessert = 1;
case 'Cake'
 disp([choice ' coming right up.'])
 dessert = 2;
case 'No thank you'
 disp('I'll bring you your check.')
```

```
 dessert = 0;
end
```

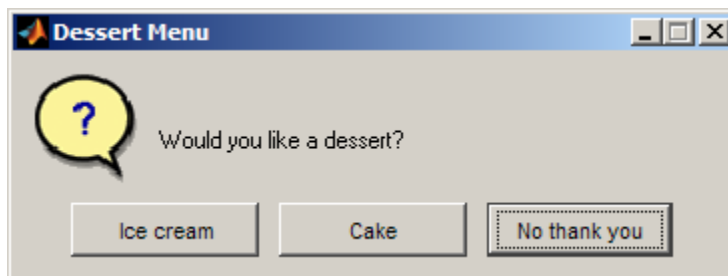

To access the return value assigned to `dessert`, save the example as a function, for example `choosedessert`, by inserting this line on top:

```
function dessert = choosedessert
```

You can generalize the function by providing the cases as string or cell array calling arguments.

As the example shows, case statements can contain white space (but are case-sensitive).

## Example 2

Specify an options structure to use the TeX interpreter to format a question.

```
options.Interpreter = 'tex';
% Include the desired Default answer
options.Default = 'Don''t know';
% Create a TeX string for the question
qstring = 'Is $\Sigma(\alpha - \beta) < 0$?';
choice = questdlg(qstring,'Boundary Condition',...
 'Yes','No','Don''t know',options)
```

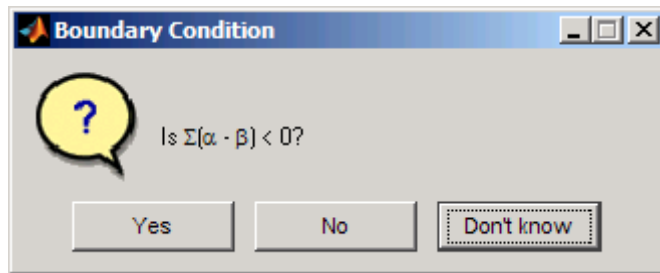
**See Also**

dialog | errordlg | helpdlg | inputdlg | listdlg | msgbox |  
warndlg | figure | textwrap | uiwait | uiresume

# quit

---

**Purpose** Terminate MATLAB program

**Alternatives** As an alternative to the quit function, use the Close box in the MATLAB desktop.

**Syntax**

```
quit
quit cancel
quit force
```

**Description** quit displays a confirmation dialog box if the confirm upon quitting preference is selected, and if confirmed or if the confirmation preference is not selected, terminates MATLAB after running `finish.m`, if `finish.m` exists. The workspace is not automatically saved by quit. To save the workspace or perform other actions when quitting, create a `finish.m` file to perform those actions. For example, you can display a custom dialog box to confirm quitting using a `finish.m` file—see the following examples for details. If an error occurs while `finish.m` is running, quit is canceled so that you can correct your `finish.m` file without losing your workspace.

quit **cancel** is for use in `finish.m` and cancels quitting. It has no effect anywhere else.

quit **force** bypasses `finish.m` and terminates MATLAB. Use this to override `finish.m`, for example, if an errant `finish.m` will not let you quit.

**Tips** When using Handle Graphics objects in `finish.m`, use `uiwait`, `waitfor`, or `drawnow` so that figures are visible. See the reference pages for these functions for more information.

If you want MATLAB to display the following confirmation dialog box after running quit, select **Preferences** in the **Environment** section on the **Home** tab. Then select the check box for Confirm before exiting MATLAB, and click **OK**.



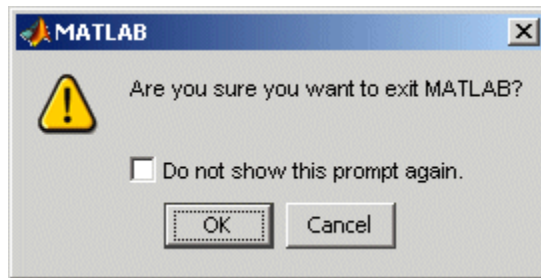

## Examples

Two sample `finish.m` files are included with MATLAB. Use them to help you create your own `finish.m`, or rename one of the files to `finish.m` to use it.

- `finishesav.m`—Saves the workspace to a MAT-file when MATLAB quits.
- `finishdlg.m`—Displays a dialog allowing you to cancel quitting; it uses `quit cancel` and contains the following code:

```
button = questdlg('Ready to quit?', ...
 'Exit Dialog', 'Yes', 'No', 'No');
switch button
 case 'Yes',
 disp('Exiting MATLAB');
 %Save variables to matlab.mat
 save
 case 'No',
 quit cancel;
end
```

## See Also

`exit` | `save` | `finish` | `startup`

## How To

- “Stop Execution”

# Quit (COM)

---

**Purpose** Terminate MATLAB Automation server

**Syntax** **IDL Method Signature**

`void Quit(void)`

**Microsoft Visual Basic Client**

`Quit`

**MATLAB Client**

`h.Quit`

`Quit(h)`

**Description** `h.Quit` terminates the MATLAB server session attached to handle `h`. The MATLAB object is active until all references have been released, such as when the variable in a function call goes out of scope.

The function name is case-sensitive.

`Quit(h)` is an alternate syntax.

**Purpose**

Quiver or velocity plot

**Syntax**

```
quiver(x,y,u,v)
quiver(u,v)
quiver(...,scale)
quiver(...,LineStyle)
quiver(...,LineStyle,'filled')
quiver(...,'PropertyName',PropertyValue,...)
quiver(axes_handle,...)
h = quiver(...)
```

**Description**

A quiver plot displays velocity vectors as arrows with components  $(u, v)$  at the points  $(x, y)$ .

For example, the first vector is defined by components  $u(1), v(1)$  and is displayed at the point  $x(1), y(1)$ .

`quiver(x,y,u,v)` plots vectors as arrows at the coordinates specified in each corresponding pair of elements in  $x$  and  $y$ . The matrices  $x$ ,  $y$ ,  $u$ , and  $v$  must all be the same size and contain corresponding position and velocity components. However,  $x$  and  $y$  can also be vectors, as explained in the next section. By default, the arrows are scaled to just not overlap, but you can scale them to be longer or shorter if you want.

`quiver(u,v)` draws vectors specified by  $u$  and  $v$  at equally spaced points in the  $x$ - $y$  plane.

`quiver(...,scale)` automatically scales the arrows to fit within the grid and then stretches them by the factor `scale`. `scale = 2` doubles their relative length, and `scale = 0.5` halves the length. Use `scale = 0` to plot the velocity vectors without automatic scaling. You can also tune the length of arrows after they have been drawn by choosing the **Plot**

**Edit**  tool, selecting the quivergroup object, opening the Property Editor, and adjusting the **Length** slider.

`quiver(...,LineStyle)` specifies line style, marker symbol, and color using any valid `LineStyle`. `quiver` draws the markers at the origin of the vectors.

`quiver(...,LineStyle,'filled')` fills markers specified by `LineStyle`.

`quiver(...,'PropertyName',PropertyValue,...)` specifies property name and property value pairs for the quivergroup objects the function creates.

`quiver(axes_handle,...)` plots into the axes with the handle `axes_handle` instead of into the current axes (`gca`).

`h = quiver(...)` returns the handle to the quivergroup object.

## Expanding x- and y-Coordinates

MATLAB expands `x` and `y` if they are not matrices. This expansion is equivalent to calling `meshgrid` to generate matrices from vectors:

```
[x,y] = meshgrid(x,y);
quiver(x,y,u,v)
```

In this case, the following must be true:

`length(x) = n` and `length(y) = m`, where `[m,n] = size(u) = size(v)`.

The vector `x` corresponds to the columns of `u` and `v`, and vector `y` corresponds to the rows of `u` and `v`.

## Examples

### Plot Vector Velocities

Use `quiver` to display an arrow at each data point in `x` and `y` such that the arrow direction and length represent the corresponding values in `u` and `v`.

```
[x,y] = meshgrid(0:0.2:2,0:0.2:2);
u = cos(x).*y;
v = sin(x).*y;
```

figure

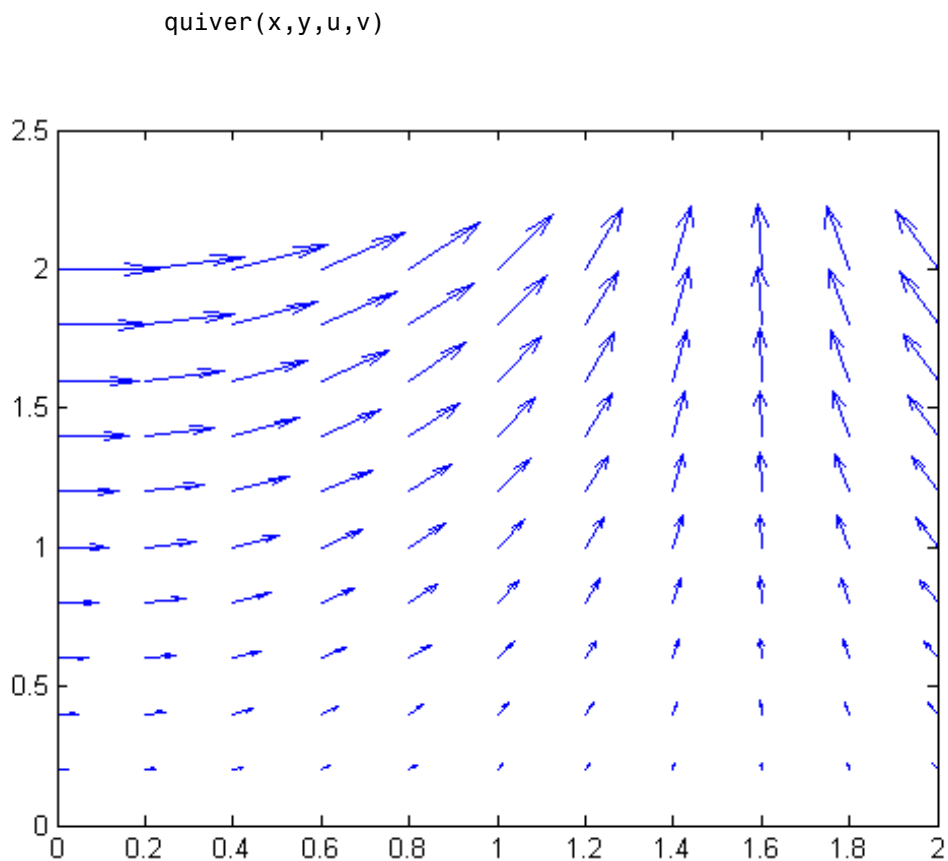

### Show Gradient with Quiver Plot

Plot the gradient of the function  $z = xe^{-x^2-y^2}$ .

```
[X,Y] = meshgrid(-2:.2:2);
Z = X.*exp(-X.^2 - Y.^2);
[DX,DY] = gradient(Z,.2,.2);
```

# quiver

```
figure
contour(X,Y,Z)
hold on
quiver(X,Y,DX,DY)
hold off
```

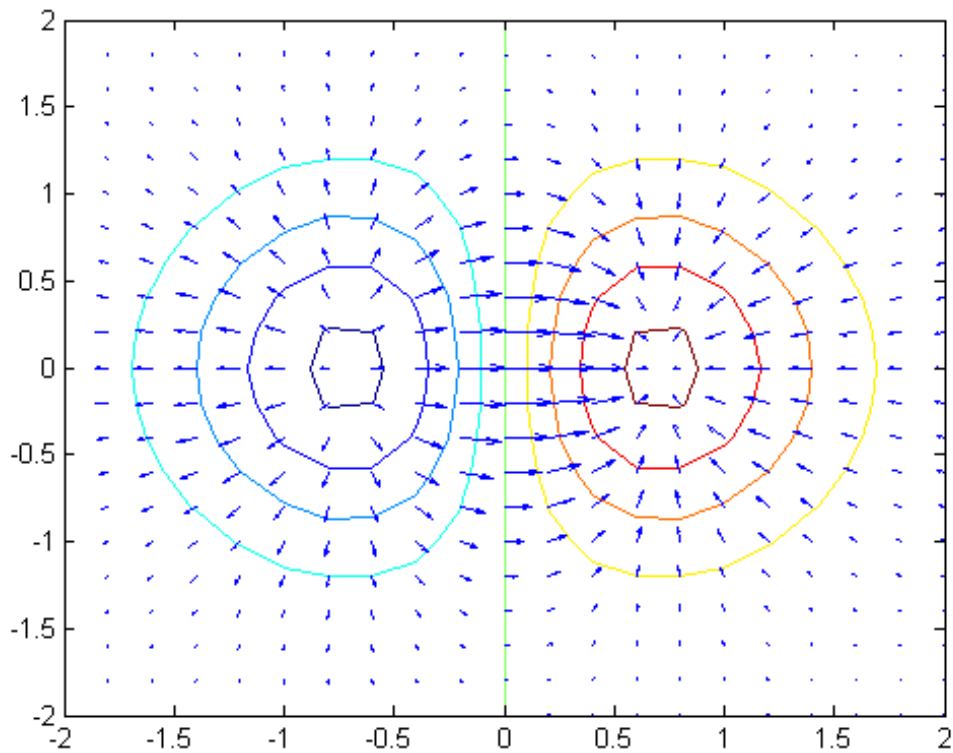

## See Also

[contour](#) | [LineSpec](#) | [plot](#) | [quiver3](#)

## How To

- “Display Quiver Plot Over Contour Plot”

**Purpose** 3-D quiver or velocity plot

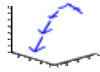

**Syntax**

```
quiver3(x,y,z,u,v,w)
quiver3(z,u,v,w)
quiver3(...,scale)
quiver3(...,LineStyle)
quiver3(...,LineStyle,'filled')
quiver3(...,'PropertyName',PropertyValue,...)
quiver3(axes_handle,...)
h = quiver3(...)
```

**Description** A three-dimensional quiver plot displays vectors with components  $(u,v,w)$  at the points  $(x,y,z)$ , where  $u,v,w,x,y$ , and  $z$  all have real (non-complex) values.

`quiver3(x,y,z,u,v,w)` plots vectors with directions determined by components  $(u,v,w)$  at points determined by  $(x,y,z)$ . The matrices  $x,y,z,u,v,w$  must all be the same size and contain the corresponding position and vector components.

`quiver3(z,u,v,w)` plots vectors with directions determined by components  $(u,v,w)$  at equally spaced points along the surface  $z$ . For each vector  $(u(i,j),v(i,j),w(i,j))$ , the column index  $j$  determines the  $x$ -value of the point on the surface, the row index  $i$  determines the  $y$ -value, and  $z(i,j)$  determines the  $z$ -value. That is, `quiver3` locates the vector at the point on the surface  $(j,i,z(i,j))$ . The `quiver3` function automatically scales the vectors to prevent overlapping based on the distance between them.

`quiver3(...,scale)` automatically scales the vectors to prevent them from overlapping, and then multiplies them by `scale`. `scale = 2` doubles their relative length, and `scale = 0.5` halves them. Use `scale = 0` to plot the vectors without the automatic scaling.

# quiver3

---

`quiver3(...,LineStyle)` specifies line style, marker symbol, and color using any valid `LineStyle`. `quiver3` draws the markers at the origin of the vectors.

`quiver3(...,LineStyle,'filled')` fills markers specified by `LineStyle`.

`quiver3(...,'PropertyName',PropertyValue,...)` specifies property name and property value pairs for the `quivergroup` object the function creates.

`quiver3(axes_handle,...)` plots into the axes with the handle `axes_handle` instead of into the current axes (`gca`).

`h = quiver3(...)` returns a handle to the `quivergroup` object.

## Examples

### Create 3-D Quiver Plot

Define the data.

```
x = -3:0.5:3;
y = -3:0.5:3;
[X,Y] = meshgrid(x, y);
Z = Y.^2 - X.^2;
[U,V,W] = surfnorm(Z);
```

Plot vectors with components  $(U,V,W)$  at points that are equally spaced in the  $x$ -direction and  $y$ -direction with heights determined by  $Z$ .

```
figure
quiver3(Z,U,V,W)
view(-35,45)
```



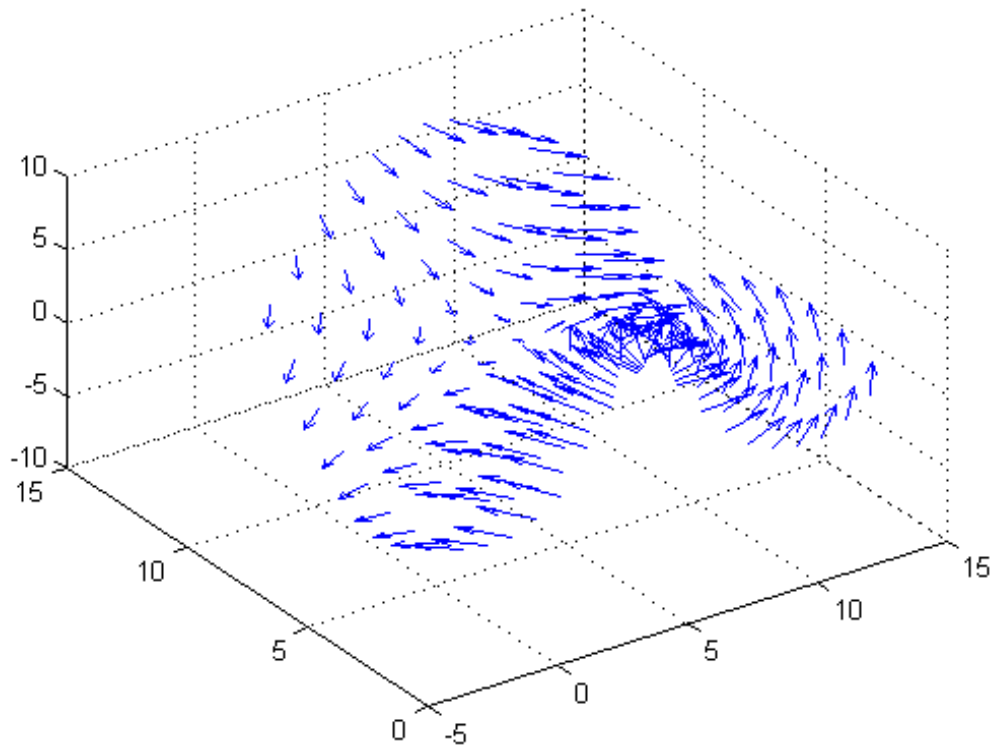

### Plot Surface Normals

Plot the surface normals of the function  $z = xe^{-x^2-y^2}$ .

```
[X,Y] = meshgrid(-2:0.25:2,-1:0.2:1);
Z = X.* exp(-X.^2 - Y.^2);
[U,V,W] = surfnorm(X,Y,Z);
```

```
figure
quiver3(X,Y,Z,U,V,W,0.5);
```

# quiver3

```
hold on
surf(X,Y,Z);
view(-35,45)
axis ([-2 2 -1 1 -.6 .6])
hold off
```

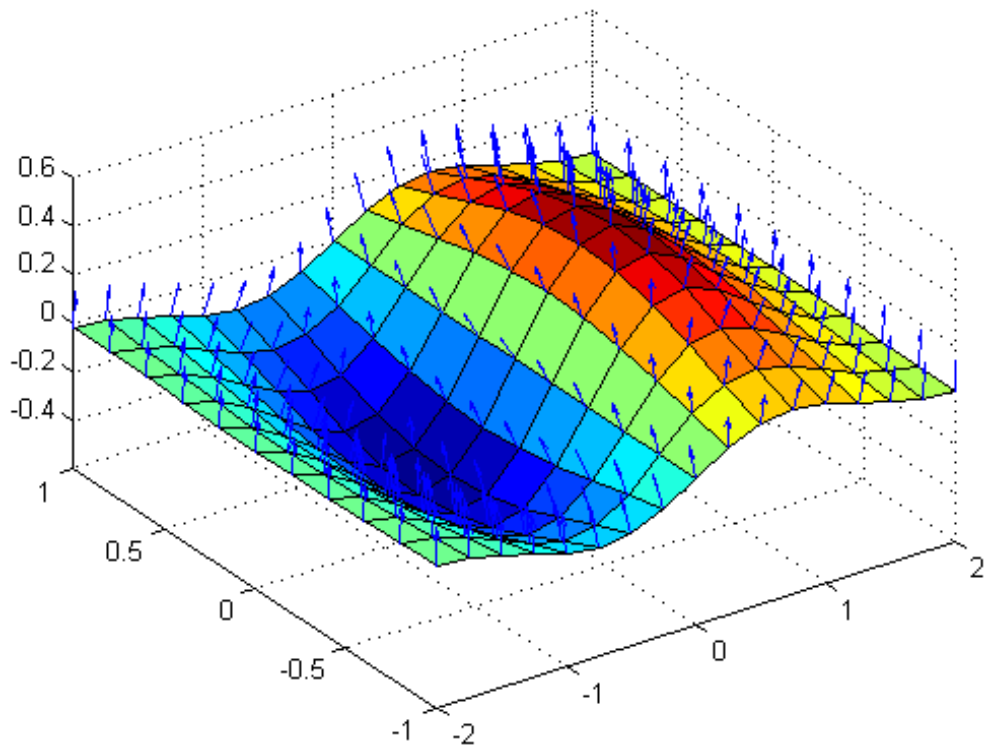

## See Also

[axis](#) | [contour](#) | [LineSpec](#) | [plot](#) | [plot3](#) | [quiver](#) | [surfnorm](#) | [view](#)

**How To**

- “Projectile Path Over Time”

# Quivergroup Properties

---

**Purpose** Define quivergroup properties

**Modifying Properties** You can set and query graphics object properties using the set and get commands or the Property Editor (propertyeditor).

Note that you cannot define default properties for quivergroup objects. See Plot Objects for more information on quivergroup objects.

**Quivergroup Property Descriptions** This section provides a description of properties. Curly braces { } enclose default values.

Annotation

hg.Annotation object (read-only)

*Control the display of quivergroup objects in legends.* Specifies whether this quivergroup object is represented in a figure legend.

Querying the Annotation property returns the handle of an hg.Annotation object. The hg.Annotation object has a property called LegendInformation, which contains an hg.LegendEntry object.

Once you have obtained the hg.LegendEntry object, you can set its IconDisplayStyle property to control whether the quivergroup object is displayed in a figure legend.

IconDisplayStyle Value	Purpose
on	Include the quivergroup object in a legend as one entry, but not its children objects
off	Do not include the quivergroup or its children in a legend (default)
children	Include only the children of the quivergroup as separate entries in the legend

## Setting the IconDisplayStyle Property

These commands set the `IconDisplayStyle` of a graphics object with handle `hobj` to `children`, which causes each child object to have an entry in the legend:

```
hAnnotation = get(hobj, 'Annotation');
hLegendEntry = get(hAnnotation, 'LegendInformation');
set(hLegendEntry, 'IconDisplayStyle', 'children')
```

## Using the IconDisplayStyle Property

See “Control Legend Content” for more information and examples.

### AutoScale

{on} | off

*Autoscale arrow length.* Based on average spacing in the  $x$  and  $y$  directions, `AutoScale` scales the arrow length to fit within the grid-defined coordinate data and keeps the arrows from overlapping. After autoscaling, `quiver` applies the `AutoScaleFactor` to the arrow length.

### AutoScaleFactor

scalar (default = 0.9)

*User-specified scale factor.* When `AutoScale` is on, the `quiver` function applies this user-specified autoscale factor to the arrow length. A value of 2 doubles the length of the arrows; 0.5 halves the length.

### BeingDeleted

on | {off} (read-only)

*This object is being deleted.* Mechanism to determine if objects are in the process of being deleted. MATLAB sets the `BeingDeleted` property to `on` when the object’s delete function callback is called (see the `DeleteFcn` property). It remains set to `on` while the delete function executes, after which the object no longer exists.

# Quivergroup Properties

---

For example, an object's delete function calls other functions that act on a number of different objects. If a function does not need to perform an action on an about-be-deleted object, it can check the object's `BeingDeleted` property before acting.

## BusyAction

cancel | {queue}

### *Callback queuing*

Determines how MATLAB handles the execution of interrupting callbacks.

A *running* callback is the currently executing callback. The *interrupting* callback is the callback that tries to interrupt the *running* callback. The `BusyAction` property of the *interrupting* callback determines how MATLAB handles its execution. When the `BusyAction` property is set to:

- 'queue' — Puts the *interrupting* callback in a queue to be processed after the *running* callback finishes execution.
- 'cancel' — Discards the *interrupting* callback as MATLAB finishes execution.

For information about how the `Interruptible` property of the callback controls whether other callbacks can interrupt the *running* callback, see the `Interruptible` property description.

## ButtonDownFcn

string | function handle

*Button press callback function.* Executes whenever you press a mouse button while the pointer is over this object, but not over another graphics object. See the `HitTestArea` property for information about selecting objects of this type.

See the figure's `SelectionType` property to determine if modifier keys were also pressed.

This property can be:

- A string that is a valid MATLAB expression
- The name of a MATLAB file
- A function handle

Set this property to a function handle that references the callback. The expressions execute in the MATLAB workspace.

For information on the syntax of callback functions, see [Function Handle Callbacks](#).

## Children

array of graphics object handles

*Children of the quivergroup object.* An array containing the handles of all line objects parented to this object (whether visible or not).

If a child object's `HandleVisibility` property is `callback` or `off`, its handle does not show up in this object's `Children` property. If you want the handle in the `Children` property, set the root `ShowHiddenHandles` property to `on`. For example:

```
set(0, 'ShowHiddenHandles', 'on')
```

## Clipping

{on} | off

*Clipping mode.* MATLAB clips graphs to the axes plot box by default. If you set `Clipping` to `off`, portions of graphs appear outside the axes plot box. This occurs if you create a plot object, set `hold` to `on`, freeze axis scaling (`axis manual`), and then create a larger plot object.

## Color

ColorSpec

# Quivergroup Properties

---

*Color of the object.* A three-element RGB vector or one of the MATLAB predefined names, specifying the object's color. The default value is [0 0 0] (black).

See the `ColorSpec` reference page for more information on specifying color. See “Adding Arrows and Lines to Graphs”.

## `CreateFcn`

function handle | cell array containing function handle and additional arguments | string (not recommended)

*Callback function executed during object creation.* Defines a callback that executes when MATLAB creates an object. The default is an empty array.

You must specify the callback during the creation of the object. For example:

```
graphicfcn(y, 'CreateFcn', @CallbackFcn)
```

where `@CallbackFcn` is a function handle that references the callback function and `graphicfcn` is the plotting function which creates this object.

MATLAB executes this routine after setting all other object properties. Setting this property on an existing object has no effect.

The handle of the object whose `CreateFcn` is being executed is accessible only through the root `CallbackObject` property, which you can query using `gcbo`.

For information on the syntax of callback functions, see `Function Handle Callbacks`.

## `DeleteFcn`

function handle | cell array containing function handle and additional arguments | string (not recommended)



*Callback executed during object deletion.* Executes when this object is deleted (for example, this might happen when you issue a `delete` command on the object, its parent axes, or the figure containing it). MATLAB executes the callback before destroying the object's properties so the callback routine can query these values. The default is an empty array.

The handle of the object whose `DeleteFcn` is being executed is accessible only through the root `CallbackObject` property, which can be queried using `gcb0`.

For information on the syntax of callback functions, see [Function Handle Callbacks](#).

See the `BeingDeleted` property for related information.

`DisplayName`  
string

*String used by legend.* The `legend` function uses the `DisplayName` property to label the quivergroup object in the legend. The default is an empty string.

- If you specify string arguments with the `legend` function, MATLAB set `DisplayName` to the corresponding string and uses that string for the legend.
- If `DisplayName` is empty, `legend` creates a string of the form, `['data' n]`, where `n` is the number assigned to the object based on its location in the list of legend entries. However, `legend` does not set `DisplayName` to this string.
- If you edit the string directly in an existing legend, MATLAB set `DisplayName` to the edited string.
- If you specify a string for the `DisplayName` property and create the legend using the figure toolbar, then MATLAB uses the string defined by `DisplayName`.

# Quivergroup Properties

---

- To add a legend programmatically that uses the `DisplayName` string, call `legend` with the `toggle` or `show` option.

See “Control Legend Content” for more information and examples.

## EraseMode

{normal} | none | xor | background

*Erase mode.* Controls the technique MATLAB uses to draw and erase objects. Use alternative erase modes for creating animated sequences, where control of the way individual objects are redrawn is necessary to improve performance and obtain the desired effect.

- `normal` — Redraw the affected region of the display, performing the three-dimensional analysis necessary to correctly render all objects. This mode produces the most accurate picture, but is the slowest. The other modes are faster, but do not perform a complete redraw and are therefore less accurate.
- `none` — Do not erase the object when it is moved or destroyed. While the object is still visible on the screen after erasing with `EraseMode none`, you cannot print it because MATLAB stores no information about its former location.
- `xor` — Draw and erase the object by performing an exclusive OR (XOR) with the color of the screen beneath it. This mode does not damage the color of the objects beneath it. However, the object’s color depends on the color of whatever is beneath it on the display.
- `background` — Erase the object by redrawing it in the axes background `Color`, or the figure background `Color` if the axes `Color` property is `none`. This damages objects that are behind the erased object, but properly colors the erased object.

Set the axes background color with the axes `Color` property. Set the figure background color with the figure `Color` property.

## Printing with Nonnormal Erase Modes

MATLAB always prints figures as if the `EraseMode` of all objects is `normal`. This means graphics objects created with `EraseMode` set to `none`, `xor`, or `background` can look different on screen than on paper. On screen, MATLAB mathematically combines layers of colors (for example, performing an XOR on a pixel color with that of the pixel behind it) and ignore three-dimensional sorting to obtain greater rendering speed. However, these techniques are not applied to the printed output.

You can use the `getframe` command or other screen capture applications to create an image of a figure containing nonnormal mode objects.

## HandleVisibility

`{on} | callback | off`

*Control access to object's handle.* Determines when an object's handle is visible in its parent's list of children. `HandleVisibility` is useful for preventing command-line users from accidentally accessing objects that you need to protect for some reason.

- `on` — Handles are always visible.
- `callback` — Handles are visible from within callback routines or functions invoked by callback routines, but not from within functions invoked from the command line. This provides a means to protect GUIs from command-line users, while allowing callback routines to have access to object handles.
- `off` — Handles are invisible at all times. Use this option when a callback invokes a function that could damage the GUI (such as evaluating a user-typed string). This option temporarily hides its own handles during the execution of that function.

## Functions Affected by Handle Visibility

When a handle is not visible in its parent's list of children, it cannot be returned by functions that obtain handles by searching

# Quivergroup Properties

---

the object hierarchy or querying handle properties. This includes `get`, `findobj`, `gca`, `gcf`, `gco`, `newplot`, `cla`, `clf`, and `close`.

## Properties Affected by Handle Visibility

When a handle's visibility is restricted using `callback` or `off`, the object's handle does not appear in its parent's `Children` property, figures do not appear in the root's `CurrentFigure` property, objects do not appear in the root's `CallbackObject` property or in the figure's `CurrentObject` property, and axes do not appear in their parent's `CurrentAxes` property.

## Overriding Handle Visibility

You can set the root `ShowHiddenHandles` property to `on` to make all handles visible regardless of their `HandleVisibility` settings. This does not affect the values of the `HandleVisibility` properties. See also `findall`.

## Handle Validity

Hidden handles are still valid. If you know an object's handle, you can `set` and `get` its properties and pass it to any function that operates on handles.

---

**Note** If you change one data source property to a variable that contains data of a different dimension, you might cause the function to generate a warning and not render the graph until you have changed all data source properties to appropriate values.

---

`HitTest`  
{on} | off

*Selectable by mouse click.* Determines whether this object can become the current object (as returned by the `gco` command and

the figure `CurrentObject` property) as a result of a mouse click on the line objects that compose the quiver plot. If `HitTest` is `off`, clicking this object selects the object below it (which is usually the axes containing it).

`HitTestArea`  
`on` | `{off}`

*Select the object by clicking lines or area of extent.* Select plot objects by:

- Clicking quiver arrows (default).
- Clicking anywhere in the extent of the plot.

When `HitTestArea` is `off`, you must click the quiver lines (excluding the baseline) to select the object. When `HitTestArea` is `on`, you can select this object by clicking anywhere within the extent of the plot (that is, anywhere within a rectangle that encloses all the arrows).

`Interruptible`  
`off` | `{on}`

*Callback routine interruption*

Controls whether MATLAB can interrupt an object's callback function when subsequent callbacks attempt to interrupt it.

For Graphics objects, the `Interruptible` property affects only the callbacks for the `ButtonDownFcn` property. A *running* callback is the currently executing callback. The *interrupting* callback is the callback that tries to interrupt the *running* callback. MATLAB handles both the callbacks based on the `Interruptible` property of the object of the *running* callback.

When the `Interruptible` property is set to:

# Quivergroup Properties

---

- 'off', MATLAB finishes execution of the *running* callback without any interruptions
- 'on', these conditions apply:
  - If there is a *drawnow*, *figure*, *getframe*, *waitfor*, or *pause* command in the *running* callback, then MATLAB executes the *interrupting* callbacks which are already in the queue and returns to finish execution of the current callback.
  - If one of the above functions is not in the *running* callback, then MATLAB finishes execution of the current callback without any interruption.

BusyAction property of the object of interrupting callback determines whether the callback should be ignored or should be put in the queue.

Setting Interruptible property to on (default), allows a callback from other graphics objects to interrupt callback functions originating from this object.

---

**Note** MATLAB does not save the state of properties or the display when an interruption occurs. For example, the handle returned by the *gca* or *gcf* command may be changed as another callback is executed.

---

After the function that interrupts a callback completes, the callback resumes execution where it halted when interrupted. For more information, see “Control Callback Execution and Interruption”.

LineStyle

{-} | -- | : | -. | none

*Line style of quivergroup object.*

## Line Style Specifiers Table

Specifier	Line Style
'-'	Solid line (default)
'--'	Dashed line
':'	Dotted line
'-.'	Dash-dot line
'none'	No line

Use `LineStyle none` when you want to place a marker at each point but do not want the points connected with a line (see the `Marker` property).

### LineWidth

size in points

*Width of linear objects and edges of filled areas. Specify in points. 1 point =  $1/72$  inch. The default is 0.5 points.*

### Marker

character (see table)

*Marker symbol.* Specifies marks that display at data points. You can set values for the `Marker` property independently from the `LineStyle` property. For a list of supported marker symbols, see the following table.

## Marker Specifiers Table

Specifier	Marker Type
'+'	Plus sign
'o'	Circle
'*'	Asterisk

# Quivergroup Properties

---

Specifier	Marker Type
'.'	Point
'x'	Cross
'square' or 's'	Square
'diamond' or 'd'	Diamond
'^'	Upward-pointing triangle
'v'	Downward-pointing triangle
'>'	Right-pointing triangle
'<'	Left-pointing triangle
'pentagram' or 'p'	Five-pointed star (pentagram)
'hexagram' or 'h' ' '	Six-pointed star (hexagram)
'none'	No marker (default)

## MarkerEdgeColor

ColorSpec | none | {auto}

*Marker edge color.* The color of the marker or the edge color for filled markers (circle, square, diamond, pentagram, hexagram, and the four triangles).

- ColorSpec — User-defined color.
- none — Specifies no color, which makes nonfilled markers invisible.
- auto — Uses same color as the Color property.

## MarkerFaceColor

ColorSpec | {none} | auto

*Fill color for closed-shape markers.* The fill color for markers that are closed shapes (circle, square, diamond, pentagram, hexagram, and the four triangles).



- `ColorSpec` — User-defined color.
- `none` — Makes the interior of the marker transparent, allowing the background to show through.
- `auto` — Sets the fill color to the axes `Color` property. If the axes `Color` property is `none`, sets the fill color to the figure `Color`.

`MarkerSize`  
scalar

*Marker size.* Size of the marker in points. The default value is 6.

---

**Note** MATLAB draws the point marker (specified by the `'.'` symbol) at one-third the specified size.

---

`MaxHeadSize`  
scalar (default = 0.2)

*Maximum size of arrowhead.* A value determining the maximum size of the arrowhead relative to the length of the arrow.

`Parent`  
handle of parent axes, `hggroup`, or `hgtransform`

*Parent of object.* Handle of the object's parent. The parent is normally the axes, `hggroup`, or `hgtransform` object that contains the object.

`Selected`  
`on` | `{off}`

*Object selection state.* When you set this property to `on`, MATLAB displays selection handles at the corners and midpoints if the `SelectionHighlight` property is also `on` (the default). You can, for example, define the `ButtonDownFcn` callback to set this property to `on`, thereby indicating that this particular object

# Quivergroup Properties

---

is selected. This property is also set to on when an object is manually selected in plot edit mode.

SelectionHighlight  
{on} | off

*Object highlighted when selected.*

- on — MATLAB indicates the selected state by drawing four edge handles and four corner handles.
- off — MATLAB does not draw the handles except when in plot edit mode and objects are selected manually.

ShowArrowHead  
{on} | off

*Display arrowheads on vectors.* When this property is on, MATLAB draws arrowheads on the vectors displayed by quiver. When you set this property to off, quiver draws the vectors as lines without arrowheads.

Tag  
string

*User-specified object label.* Provides a means to identify graphics objects with a user-specified label. The default is an empty string.

Use the Tag property and the findobj function to manipulate specific objects within a plotting hierarchy.

For example, create an areaseries object and set the Tag property.

```
t = area(Y, 'Tag', 'area1')
```

When you want to access objects of a given type, use findobj to find the object's handle. The following statement changes the FaceColor property of the object whose Tag is area1.

```
set(findobj('Tag', 'area1'), 'FaceColor', 'red')
```

## Type

string (read-only)

*Type of graphics object.* String that identifies the class of the graphics object. Use this property to find all objects of a given type within a plotting hierarchy. For stem objects, `Type` is `'hggroup'`. This statement finds all the `hggroup` objects in the current axes.

```
t = findobj(gca, 'Type', 'hggroup');
```

## UIContextMenu

handle of `uicontextmenu` object

*Associate context menu with object.* Handle of a `uicontextmenu` object created in the object's parent figure. Use the `uicontextmenu` function to create the context menu. MATLAB displays the context menu whenever you right-click over the object. The default value is an empty array.

## UserData

array

*User-specified data.* Data you want to associate with this object (including cell arrays and structures). The default value is an empty array. MATLAB does not use this data, but you can access it using the `set` and `get` commands.

## Visible

{on} | off

*Visibility of object and its children.*

- `on` — Object and all children of the object are visible unless the child object's `Visible` property is `off`.
- `off` — Object not displayed. However, the object still exists and you can set and query its properties.

## UData

matrix

# Quivergroup Properties

---

*One dimension of 2-D or 3-D vector components.* UData, VData and WData (for 3-D) together specify the components of the vectors displayed as arrows in the quiver graph. For example, the first vector is defined by components UData(1),VData(1),WData(1).

UDataSource  
string (MATLAB variable)

*Link UData to MATLAB variable.* Set this property to a MATLAB variable that, by default, is evaluated in the base workspace to generate the UData. The default value is an empty array.

```
set(h, 'UDataSource', 'Udatavariablename')
```

MATLAB requires a call to refreshdata when you set this property. Changing workspace variables used as an object's UDataSource does not change the object's UData values, but you can use refreshdata to force an update of the object's data. refreshdata also lets you specify that the data source variable be evaluated in the workspace of a function from which you call refreshdata.

---

**Note** If you change one data source property to a variable that contains data of a different dimension, you might cause the function to generate a warning and not render the graph until you have changed all data source properties to appropriate values.

---

VData  
matrix

*One dimension of 2-D or 3-D vector components.* UData, VData and WData (for 3-D) together specify the components of the vectors displayed as arrows in the quiver graph. For example, the first vector is defined by components UData(1),VData(1),WData(1).

## VDataSource

MATLAB variable, as a string

*Link VData to MATLAB variable.* Set this property to a MATLAB variable that, by default, is evaluated in the base workspace to generate the VData. The default value is an empty array.

```
set(h,'VDataSource','Vdatavariablename')
```

MATLAB requires a call to `refreshdata` when you set this property. Changing workspace variables used as an object's VDataSource does not change the object's VData values, but you can use `refreshdata` to force an update of the object's data. `refreshdata` also lets you specify that the data source variable be evaluated in the workspace of a function from which you call `refreshdata`.

---

**Note** If you change one data source property to a variable that contains data of a different dimension, you might cause the function to generate a warning and not render the graph until you have changed all data source properties to appropriate values.

---

## WData

matrix

*One dimension of 2-D or 3-D vector components.* UData, VData and WData (for 3-D) together specify the components of the vectors displayed as arrows in the quiver graph. For example, the first vector is defined by components `UData(1),VData(1),WData(1)`.

## WDataSource

MATLAB variable, as a string

*Link WData to MATLAB variable.* Set this property to a MATLAB variable that, by default, is evaluated in the base workspace to generate the WData. The default value is an empty array.

# Quivergroup Properties

---

```
set(h, 'WDataSource', 'WDatavariablename')
```

MATLAB requires a call to `refreshdata` when you set this property. Changing workspace variables used as an object's `WDataSource` does not change the object's `WData` values, but you can use `refreshdata` to force an update of the object's data. `refreshdata` also lets you specify that the data source variable be evaluated in the workspace of a function from which you call `refreshdata`.

---

**Note** If you change one data source property to a variable that contains data of a different dimension, you might cause the function to generate a warning and not render the graph until you have changed all data source properties to appropriate values.

---

## XData

vector | matrix

*X-axis coordinates of arrows.* The `quiver` function draws an individual arrow at each *x*-axis location in the `XData` array. `XData` can be either a matrix equal in size to all other data properties or for 2-D, a vector equal in length to the number of columns in `UData` or `VData`. That is, `length(XData) == size(UData,2)`.

If you do not specify `XData` (which is the input argument `X`), the `quiver` function uses the indices of `UData` to create the quiver graph. See the `XDataMode` property for related information.

## XDataMode

{auto} | manual

*Use automatic or user-specified x-axis values.* If you specify `XData` (by setting the `XData` property or specifying the input argument `X`), the `quiver` function sets this property to `manual`.

If you set `XDataMode` to `auto` after having specified `XData`, the `quiver` function resets the  $x$  tick-mark labels to the indices of the `U`, `V`, and `W` data, overwriting any previous values.

## `XDataSource`

MATLAB variable, as a string

*Link `XData` to MATLAB variable.* Set this property to a MATLAB variable that is evaluated in the base workspace to generate the `XData`. The default value is an empty array.

```
set(h, 'XDataSource', 'xdatabasename')
```

MATLAB requires a call to `refreshdata` when you set this property. Changing workspace variables used as an object's `XDataSource` does not change the object's `XData` values, but you can use `refreshdata` to force an update of the object's data. `refreshdata` also lets you specify that the data source variable be evaluated in the workspace of a function from which you call `refreshdata`.

---

**Note** If you change one data source property to a variable that contains data of a different dimension, you might cause the function to generate a warning and not render the graph until you have changed all data source properties to appropriate values.

---

## `YData`

vector | matrix

*Y-axis coordinates of arrows.* The `quiver` function draws an individual arrow at each  $y$ -axis location in the `YData` array. `YData` can be either a matrix equal in size to all other data properties or for 2-D, a vector equal in length to the number of rows in `UData` or `VData`. That is, `length(YData) == size(UData,1)`.

# Quivergroup Properties

---

If you do not specify `YData` (which is the input argument `Y`), the `quiver` function uses the indices of `VData` to create the quiver graph. See the `YDataMode` property for related information.

The input argument `Y` in the `quiver` function calling syntax assigns values to `YData`.

`YDataMode`  
{auto} | manual

*Use automatic or user-specified y-axis values.* If you specify `YData` (by setting the `YData` property or specifying the input argument `Y`), MATLAB sets this property to `manual`.

If you set `YDataMode` to `auto` after having specified `YData`, MATLAB resets the `y` tick-mark labels to the indices of the `U`, `V`, and `W` data, overwriting any previous values.

`YDataSource`  
MATLAB variable, as a string

*Link YData to MATLAB variable.* Set this property to a MATLAB variable that is evaluated in the base workspace to generate the `YData`. The default value is an empty array.

```
set(h, 'YDataSource', 'Ydatavariablename')
```

MATLAB requires a call to `refreshdata` when you set this property. Changing workspace variables used as an object's `YDataSource` does not change the object's `YData` values, but you can use `refreshdata` to force an update of the object's data. `refreshdata` also lets you specify that the data source variable be evaluated in the workspace of a function from which you call `refreshdata`.



---

**Note** If you change one data source property to a variable that contains data of a different dimension, you might cause the function to generate a warning and not render the graph until you have changed all data source properties to appropriate values.

---

## ZData

vector | matrix

*Z-axis coordinates of arrows.* The `quiver` function draws an individual arrow at each *z*-axis location in the `ZData` array. `ZData` must be a matrix equal in size to `XData` and `YData`.

The input argument `Z` in the `quiver3` function calling syntax assigns values to `ZData`.

**Purpose** QZ factorization for generalized eigenvalues

**Syntax**  
 $[AA, BB, Q, Z] = \text{qz}(A, B)$   
 $[AA, BB, Q, Z, V, W] = \text{qz}(A, B)$   
 $\text{qz}(A, B, \text{flag})$

**Description** The `qz` function gives access to intermediate results in the computation of generalized eigenvalues.

$[AA, BB, Q, Z] = \text{qz}(A, B)$  for square matrices  $A$  and  $B$ , produces upper quasitriangular matrices  $AA$  and  $BB$ , and unitary matrices  $Q$  and  $Z$  such that  $Q^*A^*Z = AA$ , and  $Q^*B^*Z = BB$ . For complex matrices,  $AA$  and  $BB$  are triangular.

$[AA, BB, Q, Z, V, W] = \text{qz}(A, B)$  also produces matrices  $V$  and  $W$  whose columns are generalized eigenvectors.

$\text{qz}(A, B, \text{flag})$  for real matrices  $A$  and  $B$ , produces one of two decompositions depending on the value of `flag`:

'complex' Produces a possibly complex decomposition with a triangular  $AA$ . For compatibility with earlier versions, 'complex' is the default.

'real' Produces a real decomposition with a quasitriangular  $AA$ , containing 1-by-1 and 2-by-2 blocks on its diagonal.

If  $AA$  is triangular, the diagonal elements of  $AA$  and  $BB$ ,  $\alpha = \text{diag}(AA)$  and  $\beta = \text{diag}(BB)$ , are the generalized eigenvalues that satisfy

$$A * V * \beta = B * V * \alpha$$
$$\beta' * W' * A = \alpha' * W' * B$$

The eigenvalues produced by

$$\lambda = \text{eig}(A, B)$$

---

are the ratios of the  $\alpha$ s and  $\beta$ s.

$$\lambda = \alpha / \beta$$

If  $AA$  is not triangular, it is necessary to further reduce the 2-by-2 blocks to obtain the eigenvalues of the full system.

**See Also**

eig

# rand

---

**Purpose** Uniformly distributed pseudorandom numbers

**Syntax**

```
r = rand
r = rand(n)
r = rand(sz1, ..., szN)
r = rand(sz)

r = rand(classname)
r = rand(n,classname)
r = rand(sz1, ..., szN,classname)
r = rand(sz,classname)

r = rand('like',p)
r = rand(n,'like',p)
r = rand(sz1, ..., szN,'like',p)
r = rand(sz,'like',p)
```

**Description** `r = rand` returns a pseudorandom scalar drawn from the standard uniform distribution on the open interval (0,1).

`r = rand(n)` returns an n-by-n matrix of pseudorandom uniform values.

`r = rand(sz1, ..., szN)` returns a sz1-by-...-by-szN array of pseudorandom uniform values where `sz1, ..., szN` indicates the size of each dimension. For example, `rand(3,4)` returns a 3-by-4 array of pseudorandom values.

`r = rand(sz)` is an array of pseudorandom uniform values where the size vector, `sz`, defines `size(r)`. For example, `rand([3,4])` returns a 3-by-4 array of pseudorandom values.

---

**Note** The size inputs `sz1, ..., szN`, as well as the elements of the size vector `sz`, should be nonnegative integers. Negative integers are treated as 0.

---

`r = rand(classname)` returns a pseudorandom uniform value where the string, `classname`, specifies the data type. `classname` can be either 'single' or 'double'.

`r = rand(n,classname)` returns an `n`-by-`n` array of pseudorandom uniform values of data type `classname`.

`r = rand(sz1, ..., szN,classname)` returns a `sz1`-by-...-by-`szN` array of pseudorandom uniform values of data type `classname`.

`r = rand(sz,classname)` returns an array of pseudorandom uniform values where the size vector, `sz`, defines `size(r)` and `classname` defines `class(r)`.

`r = rand('like',p)` returns a pseudorandom uniform value of the same data type as the numeric variable, `p`.

`r = rand(n, 'like', p)` returns an `n`-by-`n` array of pseudorandom uniform values like `p`.

`r = rand(sz1, ..., szN, 'like', p)` returns a `sz1`-by-...-by-`szN` array of pseudorandom uniform values like `p`

`r = rand(sz, 'like', p)` returns an array of pseudorandom uniform values like `p` where the size vector, `sz`, defines `size(r)`.

# rand

---

The sequence of numbers produced by `rand` is determined by the internal settings of the uniform random number generator that underlies `rand`, `randi`, and `randn`. You can control that shared random number generator using `rng`.

---

**Note** Use the `rng` function instead of `rand` or `randn` with the `'seed'`, `'state'`, or `'twister'` inputs. For more information, see “Replace Discouraged Syntaxes of `rand` and `randn`”

---

## Examples

### Example 1

Generate values from the uniform distribution on the interval `[a, b]`:

```
r = a + (b-a).*rand(100,1);
```

### Example 2

Use the `randi` function, instead of `rand`, to generate integer values from the uniform distribution on the set `1:100`:

```
r = randi(100,1,5);
```

### Example 3

Reset the random number generator used by `rand`, `randi`, and `randn` to its default startup settings, so that `rand` produces the same random numbers as if you restarted MATLAB:

```
rng('default')
rand(1,5)
ans =
 0.8147 0.9058 0.1270 0.9134 0.6324
```

### Example 4

Save the settings for the random number generator used by `rand`, `randi`, and `randn`, generate 5 values from `rand`, restore the settings, and repeat those values:

```
s = rng;
u1 = rand(1,5)
u1 =
 0.0975 0.2785 0.5469 0.9575 0.9649

rng(s);
u2 = rand(1,5)
u2 =
 0.0975 0.2785 0.5469 0.9575 0.9649
```

u2 contains exactly the same values as u1.

### Example 5

Reinitialize the random number generator used by `rand`, `randi`, and `randn` with a seed based on the current time. `rand` returns different values each time you do this. Note that it is usually not necessary to do this more than once per MATLAB session as it may affect the statistical properties of the random numbers MATLAB produces:

```
rng('shuffle');
rand(1,5);
```

### See Also

`randi` | `randn` | `rng` | `@RandStream` | `rand (RandStream)` | `sprand` | `sprandn` | `randperm`

### Related Examples

- “Random Numbers within a Specific Range”

### Concepts

- “Class Support for Array-Creation Functions”

# rand (RandStream)

---

**Purpose** Uniformly distributed random numbers

**Class** RandStream

**Syntax**

```
r = rand(s,n)
r = rand(s,m,n)
r = rand(s,[m,n])
r = rand(s,m,n,p,...)
r = rand(s,[m,n,p,...])
r = rand(s)
r = rand(s,size(A))
r = rand(..., 'double')
r = rand(..., 'single')
```

**Description**

`r = rand(s,n)` returns an  $n$ -by- $n$  matrix containing pseudorandom values drawn from the standard uniform distribution on the open interval  $(0,1)$ . The values are drawn from the random stream `s`.

`r = rand(s,m,n)` or `r = rand(s,[m,n])` returns an  $m$ -by- $n$  matrix.

`r = rand(s,m,n,p,...)` or `r = rand(s,[m,n,p,...])` returns an  $m$ -by- $n$ -by- $p$ -by-... array.

`r = rand(s)` returns a scalar.

`r = rand(s,size(A))` returns an array the same size as `A`.

`r = rand(..., 'double')` or `r = rand(..., 'single')` returns an array of uniform values of the specified class.

---

**Note** The size inputs `m`, `n`, `p`, ... should be nonnegative integers. Negative integers are treated as 0.

---

The sequence of numbers produced by `rand` is determined by the internal state of the random number stream `s`. Resetting that stream to the same fixed state allows computations to be repeated. Setting



the stream to different states leads to unique computations, however, it does not improve any statistical properties.

### See Also

rand | @RandStream | randi (RandStream) | randn (RandStream) |  
randperm (RandStream)

# randi

---

**Purpose** Uniformly distributed pseudorandom integers

**Syntax**

```
r = randi(imax)
r = randi(imax,n)
r = randi(imax,sz1,...,szN)
r = randi(imax,sz)

r = randi(imax,classname)
r = randi(imax,n,classname)
r = randi(imax,sz1,...,szN,classname)
r = randi(imax,sz,classname)

r = randi(imax,'like',p)
r = randi(imax,n,'like',p)
r = randi(imax,sz1,...,szN,'like',p)
r = randi(imax,sz,'like',p)

r = randi([imin,imax], ___)
```

**Description** `r = randi(imax)` returns a pseudorandom scalar between 1 and `imax`. This is the same as `r = randi(imax,1)`.

`r = randi(imax,n)` returns an `n`-by-`n` matrix containing pseudorandom integers drawn from the discrete uniform distribution on the interval `[1,imax]`.

`r = randi(imax,sz1,...,szN)` returns a `sz1`-by-...-by-`szN` array of pseudorandom integers where `sz1,...,szN` indicates the size of each dimension. For example, `randi(10,3,4)` returns a 3-by-4 array of pseudorandom integers between 1 and 10.

`r = randi(imax,sz)` returns an array of pseudorandom integers where the size vector, `sz`, defines `size(r)`. For example, `randi(10,[3,4])` returns a 3-by-4 array of pseudorandom integers between 1 and 10.

---

**Note** The size inputs  $sz_1, \dots, sz_N$ , as well as the elements of the size vector  $sz$ , should be nonnegative integers. Negative integers are treated as 0.

---

$r = \text{randi}(\text{imax}, \text{classname})$  returns a pseudorandom integer where the string, `classname` specifies the data type. `classname` can be 'single', 'double', 'int8', 'uint8', 'int16', 'uint16', 'int32', or 'uint32'.

$r = \text{randi}(\text{imax}, n, \text{classname})$  returns an  $n$ -by- $n$  array of pseudorandom integers of data type `classname`.

$r = \text{randi}(\text{imax}, sz_1, \dots, sz_N, \text{classname})$  returns a  $sz_1$ -by- $\dots$ -by- $sz_N$  array of pseudorandom integers of data type `classname`.

$r = \text{randi}(\text{imax}, sz, \text{classname})$  returns an array of pseudorandom integers where the size vector, `sz`, defines `size(r)` and `classname` defines `class(r)`.

$r = \text{randi}(\text{imax}, \text{'like'}, p)$  returns a pseudorandom integer of the same data type as the numeric variable, `p`.

$r = \text{randi}(\text{imax}, n, \text{'like'}, p)$  returns an  $n$ -by- $n$  array of pseudorandom integers like `p`.

$r = \text{randi}(\text{imax}, sz_1, \dots, sz_N, \text{'like'}, p)$  returns a  $sz_1$ -by- $\dots$ -by- $sz_N$  array of pseudorandom integers like `p`.

$r = \text{randi}(\text{imax}, sz, \text{'like'}, p)$  returns an array of pseudorandom integers like `p` where the size vector, `sz`, defines `size(r)`.

`r = randi([imin,imax], ___)` returns an array containing integers drawn from the discrete uniform distribution on the interval `[imin,imax]` using any of the above syntaxes.

If you specify a distribution range using two numbers, `[imin,imax]`, both numbers must be integers that satisfy  $imin \leq imax$ . If you specify the range using only the upper bound, `imax`, it must be a positive integer (greater than zero).

The sequence of numbers produced by `randi` is determined by the settings of the uniform random number generator that underlies `rand`, `randn`, and `randi`. `randi` uses one uniform random value to create each integer random value. You can control that shared random number generator using `rng`.

## Examples

### Example 1

Generate a 100-by-1 array of integer values from the uniform distribution on the set 1:10:

```
r = randi(10,100,1);
```

### Example 2

Generate a 100-by-1 array of integers drawn uniformly from 1:10:

```
r = randi(10,100,1,'uint32');
```

### Example 3

Generate a 100-by-1 array of integer values drawn uniformly from -10:10:

```
r = randi([-10 10],100,1);
```

### Example 4

Reset the random number generator used by `rand`, `randi`, and `randn` to its default startup settings, so that `randi` produces the same random numbers as if you restarted MATLAB:

```
rng('default');
```

```
randi(10,1,5)

ans =
 9 10 2 10 7
```

### Example 5

Save the settings for the random number generator used by `rand`, `randi`, and `randn`, generate 5 values from `randi`, restore the settings, and repeat those values:

```
s = rng;
i1 = randi(10,1,5)
i1 =
 1 3 6 10 10
rng(s);
i2 = randi(10,1,5)
i2 =
 1 3 6 10 10
```

`i2` contains exactly the same values as `i1`.

### Example 6

Reinitialize the random number generator used by `rand`, `randi`, and `randn` with a seed based on the current time. `randi` returns different values each time you do this. Note that it is usually not necessary to do this more than once per MATLAB session:

```
rng('shuffle');
randi(10,1,5);
```

### Tips

- The arrays returned by `randi` might contain repeated integer values. This behavior is sometimes referred to as sampling with replacement. Use `randperm` if you require all unique values.

### See Also

`rand` | `randn` | `rng` | `@RandStream` | `randi` (`RandStream`) | `randperm`

# randi

---

## **Related Examples**

- “Random Integers”

## **Concepts**

- “Class Support for Array-Creation Functions”

**Purpose** Uniformly distributed pseudorandom integers

**Class** RandStream

**Syntax**

```
r = randi(s,imax,n)
r = randi(s,imax,m,n)
r = randi(s,imax,[m,n])
r = randi(s,imax,m,n,p,...)
r = randi(s,imax,[m,n,p,...])
r = randi(s,imax)
r = randi(s,imax,size(A))
r = randi(s,[imin,imax],...)
r = randi(...,classname)
```

**Description** `r = randi(s,imax,n)` returns an n-by-n matrix containing pseudorandom integer values drawn from the discrete uniform distribution on `1:imax`. `randi` draws those values from the random stream `s`.

`r = randi(s,imax,m,n)` or `r = randi(s,imax,[m,n])` returns an m-by-n matrix.

`r = randi(s,imax,m,n,p,...)` or `r = randi(s,imax,[m,n,p,...])` returns an m-by-n-by-p-by-... array.

`r = randi(s,imax)` returns a scalar.

`r = randi(s,imax,size(A))` returns an array the same size as `A`.

`r = randi(s,[imin,imax],...)` returns an array containing integer values drawn from the discrete uniform distribution on `imin:imax`.

`r = randi(...,classname)` returns an array of integer values of class `classname`. `classname` does not support 64-bit integers.

---

**Note** The size inputs `m`, `n`, `p`, ... should be nonnegative integers. Negative integers are treated as 0.

---

## randi (RandStream)

---

The arrays returned by `randi` might contain repeated integer values. This is sometimes referred to as sampling with replacement. To get unique integer values, sometimes referred to as sampling without replacement, use `randperm (RandStream)`.

The sequence of numbers produced by `randi` is determined by the internal state of the random stream `s`. `randi` uses one uniform value from `s` to generate each integer value. Resetting `s` to the same fixed state allows computations to be repeated. Setting the stream to different states leads to unique computations, however, it does not improve any statistical properties.

### See Also

`randi` | `RandStream` | `rand (RandStream)` | `randn (RandStream)` | `randperm (RandStream)`



**Purpose**

Normally distributed pseudorandom numbers

**Syntax**

```
r = randn
r = randn(n)
r = randn(sz1,...,szN)
r = randn(sz)

r = randn(classname)
r = randn(n,classname)
r = randn(sz1,...,szN,classname)
r = randn(sz,classname)

r = randn('like',p)
r = randn(n,'like',p)
r = randn(sz1,...,szN,'like',p)
r = randn(sz,'like',p)
```

**Description**

`r = randn` returns a pseudorandom scalar drawn from the standard normal distribution.

`r = randn(n)` returns an  $n$ -by- $n$  matrix containing pseudorandom normal values.

`r = randn(sz1,...,szN)` returns a  $sz1$ -by-...-by- $szN$  array of pseudorandom normal values where  $sz1, \dots, szN$  indicates the size of each dimension. For example, `randn(3,4)` returns a 3-by-4 array of pseudorandom values.

`r = randn(sz)` returns an array of pseudorandom normal values where the size vector, `sz`, defines `size(r)`. For example, `randn([3,4])` returns a 3-by-4 array of pseudorandom values.

---

**Note** The size inputs `sz1, ..., szN`, as well as the elements of the size vector `sz`, should be nonnegative integers. Negative integers are treated as 0.

---

`r = randn(classname)` returns a pseudorandom normal value where the string, `classname`, specifies the data type. `classname` can be either 'single' or 'double'.

`r = randn(n,classname)` returns an `n`-by-`n` array of pseudorandom normal values of data type `classname`.

`r = randn(sz1, ..., szN,classname)` returns a `sz1`-by-...-by-`szN` array of pseudorandom normal values of data type `classname`.

`r = randn(sz,classname)` returns an array of pseudorandom normal values where the size vector, `sz`, defines `size(r)` and `classname` defines `class(r)`.

`r = randn('like',p)` returns a pseudorandom normal value of the same data type as the numeric variable, `p`.

`r = randn(n, 'like', p)` returns an `n`-by-`n` array of pseudorandom normal values like `p`.

`r = randn(sz1, ..., szN, 'like', p)` returns a `sz1`-by-...-by-`szN` array of pseudorandom normal values like `p`

`r = randn(sz, 'like', p)` returns an array of pseudorandom normal values like `p` where the size vector, `sz`, defines `size(r)`.

The sequence of numbers produced by `randn` is determined by the settings of the uniform random number generator that underlies `rand`, `randn`, and `randi`. `randn` uses one or more uniform random values to create each normal random value. You can control that shared random number generator using `rng`.

---

**Note** Use the `rng` function instead of `rand` or `randn` with the 'seed', 'state', or 'twister' inputs. For more information, see “Replace Discouraged Syntaxes of `rand` and `randn`”

---

## Examples

### Example 1

Generate values from a normal distribution with mean 1 and standard deviation 2:

```
r = 1 + 2.*randn(100,1);
```

### Example 2

Generate values from a bivariate normal distribution with specified mean vector and covariance matrix:

```
mu = [1 2];
Sigma = [1 .5; .5 2]; R = chol(Sigma);
z = repmat(mu,100,1) + randn(100,2)*R;
```

### Example 3

Reset the random number generator used by `rand`, `randi`, and `randn` to its default startup settings, so that `randn` produces the same random numbers as if you restarted MATLAB:

```
rng('default');
randn(1,5)
ans =
 0.5377 1.8339 -2.2588 0.8622 0.3188
```

## Example 4

Save the settings for the random number generator used by `rand`, `randi`, and `randn`, generate 5 values from `randn`, restore the settings, and repeat those values:

```
s = rng;
z1 = randn(1,5)
z1 =
 -1.3077 -0.4336 0.3426 3.5784 2.7694
rng(s);
z2 = randn(1,5)
z2 =
 -1.3077 -0.4336 0.3426 3.5784 2.7694
```

`z2` contains exactly the same values as `z1`.

## Example 5

Reinitialize the random number generator used by `rand`, `randi`, and `randn` with a seed based on the current time. `randn` returns different values each time you do this. Note that it is usually not necessary to do this more than once per MATLAB session:

```
rng('shuffle');
randn(1,5)
```

## See Also

`rand` | `randi` | `rng` | `@RandStream` | `randn` (`RandStream`)

## Related Examples

- “Random Numbers from Normal Distribution with Specific Mean and Variance”

## Concepts

- “Class Support for Array-Creation Functions”

**Purpose** Normally distributed pseudorandom numbers

**Class** RandStream

**Syntax**

```
r = randn(s,m,n)
r = randn(s,[m,n])
r = randn(s,m,n,p,...)
r = randn(s,[m,n,p,...])
r = randn(s)
r = randn(s,size(A))
r = randn(...,'double')
r = randn(...,'single')
```

**Description**

`r = randn(s,n)` returns an n-by-n matrix containing pseudorandom values drawn from the standard normal distribution. `randn` draws those values from the random stream `s`.

`r = randn(s,m,n)` or `r = randn(s,[m,n])` returns an m-by-n matrix.

`r = randn(s,m,n,p,...)` or `r = randn(s,[m,n,p,...])` returns an m-by-n-by-p-by-... array.

`r = randn(s)` returns a scalar.

`r = randn(s,size(A))` returns an array the same size as `A`.

`r = randn(...,'double')` or `r = randn(...,'single')` returns an array of uniform values of the specified class.

---

**Note** The size inputs `m`, `n`, `p`, ... should be nonnegative integers. Negative integers are treated as 0.

---

The sequence of numbers produced by `randn` is determined by the internal state of the random stream `s`. `randn` uses one or more uniform values from `s` to generate each normal value. Resetting that stream to the same fixed state allows computations to be repeated. Setting the

## randn (RandStream)

---

stream to different states leads to unique computations, however, it does not improve any statistical properties.

### **See Also**

`randn` | `RandStream` | `rand (RandStream)` | `randi (RandStream)`

**Purpose** Random permutation

**Syntax**  
`p = randperm(n)`  
`p = randperm(n,k)`

**Description**  
`p = randperm(n)` returns a row vector containing a random permutation of the integers from 1 to *n* inclusive.  
`p = randperm(n,k)` returns a row vector containing *k* unique integers selected randomly from 1 to *n* inclusive.

**Tips**  
For `p = randperm(n,k)`, `p` contains *k* *unique* values. `randperm` performs *k*-permutations (sampling without replacement). To allow repeated values in the output (sampling with replacement), use `randi(n,1,k)`.  
`randperm` uses the same random number generator as `rand`, `randi`, and `randn`. You control this generator with `rng`.

**Examples**  
`randperm(6)`  
might be the vector  
`[3 2 6 4 1 5]`

or it might be some other permutation of the integers from 1 to 6, depending on the state of the random number generator. Two successive calls to `randperm` would in most cases return two different vectors:

```
randperm(6)
ans =
 5 2 6 4 1 3
```

```
randperm(6)
ans =
 4 1 6 2 3 5
```

---

# randperm

---

`randperm(6,3)`

might be the vector

`[4 2 5]`

or it might be some other permutation of any three integers from 1 to 6 inclusive, depending on the state of the random number generator.

## **See Also**

`permute` | `nchoosek` | `randi` | `randperm(RandStream)` | `perms` | `rng`



**Purpose** Random permutation

**Class** RandStream

**Syntax**  
`p = randperm(s,n)`  
`p = randperm(s,n,k)`

**Description** `p = randperm(s,n)` returns a row vector containing a random permutation of integers from 1 to *n* inclusive. `randperm(s,n)` uses random values drawn from the random stream *s*.

`p = randperm(s,n,k)` returns a row vector containing *k* unique integers selected randomly from 1 to *n* inclusive.

**Tips** For `p = randperm(s,n,k)`, *p* contains *k* *unique* values. `randperm` performs *k*-permutations (sampling without replacement). To allow repeated values in the output (sampling with replacement), use `randi(s,n,1,k)`.

**Examples** Create a random stream *s* and generate a random permutation of the integers from 1 to 6 based on *s*:

```
s = RandStream('mt19937ar','Seed',0);
randperm(s,6)
```

MATLAB returns the vector

```
[6 3 5 1 2 4]
```

Use the random stream *s* to generate three integers between 1 and 10:

```
randperm(s,10,3)
ans =
 1 8 9
```

**See Also** `permute` | `randperm` | `nchoosek` | `perms` | `rand` | `randi` (RandStream)

# RandStream

---

**Purpose** Random number stream

**Constructor** RandStream

**Description** Pseudorandom numbers in MATLAB come from one or more random number streams. The simplest way to generate arrays of random numbers is to use `rand`, `randn`, or `randi`. These functions all rely on the same stream of uniform random numbers, known as the *global stream*. You can create other streams that act separately from the global stream, and you can use their `rand`, `randi`, or `randn` methods to generate arrays of random numbers. You can also create a random number stream and make it the global stream.

To create a single random number stream, use the `RandStream` constructor. To create multiple independent random number streams, use `RandStream.create`. The `rng` function provides a simple interface to create a new global stream.

`stream = RandStream.getGlobalStream` returns the global random number stream, that is, the one currently used by the `rand`, `randi`, and `randn` functions.

`prevstream = RandStream.setGlobalStream(stream)` designates the random number stream `stream` as the new global stream to be used by the `rand`, `randi`, and `randn` functions, and returns the previous global stream.

A random number stream `s` has properties that control its behavior. Access or assign to a property using `p = s.Property` or `s.Property = p`. The following table lists defined properties:

## Properties

Property	Description
Type	(Read-only) Generator algorithm used by the stream. The list of possible generators is given by <code>RandStream.list</code> .
Seed	(Read-only) Seed value used to create the stream.
NumStreams	(Read-only) Number of streams in the group in which the current stream was created.
StreamIndex	(Read-only) Index of the current stream from among the group of streams with which it was created.
State	<p>Internal state of the generator. You should not depend on the format of this property. The value you assign to <code>S.State</code> must be a value read from <code>S.State</code> previously. Use <code>reset</code> to return a stream to a predictable state without having previously read from the <code>State</code> property.</p> <p>The sequence of random numbers produced by a random number stream <code>s</code> is determined by the internal state of its random number generator. Saving and restoring the generator's internal state with the <code>State</code> property allows you to reproduce a sequence of random numbers.</p>

# RandStream

---

Property	Description
Substream	Index of the substream to which the stream is currently set. The default is 1. Multiple substreams are not supported by all generator types; the multiplicative lagged Fibonacci generator ( <code>m1fg6331_64</code> ) and combined multiple recursive generator ( <code>mrg32k3a</code> ) support substreams.
NormalTransform	Transformation algorithm used by <code>randn(s, ...)</code> to generate normal pseudorandom values. Possible values are 'Ziggurat', 'Polar', or 'Inversion'.
Antithetic	Logical value indicating whether <code>S</code> generates antithetic pseudorandom values, that is, the usual values subtracted from 1. The default is false.
FullPrecision	Logical value indicating whether <code>S</code> generates values using its full precision. Some generators can create pseudorandom values faster, but with fewer random bits, if <code>FullPrecision</code> is false. The default is true.

## Methods

Method	Description
<code>RandStream</code>	Create a random number stream.
<code>RandStream.create</code>	Create multiple independent random number streams.
<code>get</code>	Get the properties of a random stream object.

Method	Description
list	List available random number generator algorithms.
set	Set random stream property.
RandStream.getGlobalStream	Get the global random number stream.
RandStream.setGlobalStream	Set global random number stream.
reset	Reset a stream to its initial internal state
rand	Pseudorandom numbers from a uniform distribution
randn	Pseudorandom numbers from a standard normal distribution
randi	Pseudorandom integers from a uniform discrete distribution
randperm	Random permutation of a set of values

## Examples

### Example 1

Create a single stream and designate it as the current global stream:

```
s = RandStream('mt19937ar','Seed',1);
RandStream.setGlobalStream(s);
```

### Example 2

Create three independent streams:

```
[s1,s2,s3] = RandStream.create('mrg32k3a','NumStreams',3);
r1 = rand(s1,100000,1);
r2 = rand(s2,100000,1);
r3 = rand(s3,100000,1);
corrcoef([r1,r2,r3])
```

## Example 3

Create only one stream from a set of three independent streams, and designate it as the current global stream:

```
s2 = RandStream.create('mrg32k3a','NumStreams',3,...
 'StreamIndices',2);
RandStream.setGlobalStream(s2);
```

## Example 4

Reset the global random number stream that underlies `rand`, `randi`, and `randn` back to its beginning, to reproduce previous results:

```
stream = RandStream.getGlobalStream;
reset(stream);
```

## Example 5

Save and restore the current global stream's state to reproduce the output of `rand`:

```
stream = RandStream.getGlobalStream;
savedState = stream.State;
u1 = rand(1,5)
u1 =
 0.8147 0.9058 0.1270 0.9134 0.6324

stream.State = savedState;
u2 = rand(1,5)
u2 =
 0.8147 0.9058 0.1270 0.9134 0.6324
```

`u2` contains exactly the same values as `u1`.

## Example 6

Reset the global random number stream to its initial settings. This causes `rand`, `randi`, and `randn` to start over, as if in a new MATLAB session:

```
s = RandStream('mt19937ar','Seed',0);
```

```
RandStream.setGlobalStream(s);
```

## Example 7

Reinitialize the global random number stream using a seed based on the current time. This causes `rand`, `randi`, and `randn` to return different values in different MATLAB sessions. It is usually not desirable to do this more than once per MATLAB session as it may affect the statistical properties of the random numbers MATLAB produces:

```
s = RandStream('mt19937ar','Seed','shuffle');
RandStream.setGlobalStream(s);
```

## Example 8

Change the transformation algorithm that `randn` uses to create normal pseudorandom values from uniform values. This does not replace or reset the global stream.

```
stream = RandStream.getGlobalStream;
stream.NormalTransform = 'inversion'
```

## See Also

[rand](#) | [rng](#) | [randn](#) | [randi](#)

# RandStream constructor

---

**Purpose** Random number stream

**Class** RandStream

**Syntax**  
`s = RandStream('gentype')`  
`s = RandStream('gentype',Name,Value)`

**Description** `s = RandStream('gentype')` creates a random number stream that uses the uniform pseudorandom number generator algorithm specified by `gentype`. `RandStream.list` returns all possible values for `gentype`, or see “Choosing a Random Number Generator” for details on generator algorithms.

`s = RandStream('gentype',Name,Value)` allows you to specify one or more optional `Name,Value` pairs to control creation of the stream.

Once you have created a random, you can use `RandStream.setGlobalStream` to make it the global stream, so that the functions `rand`, `randi`, and `randn` draw values from it.

Parameters for `RandStream` are:

Parameter	Description
Seed	Nonnegative scalar integer with which to initialize all streams. Seeds must be an integer between 0 and $2^{32} - 1$ or 'shuffle' to create a seed based on the current time. Default is 0.
NormalTransform	Transformation algorithm used by <code>randn(s, ...)</code> to generate normal pseudorandom values. Possible values are 'Ziggurat', 'Polar', or 'Inversion'.



## Examples

### Example 1

Create a random number stream, make it the global stream, and save and restore its state to reproduce the output of `randn`:

```
s = RandStream('mrg32k3a');
RandStream.setGlobalStream(s);
savedState = s.State;
z1 = randn(1,5)
z1 =
 -0.1894 -1.4426 -0.3592 0.8883 -0.4337
s.State = savedState;
z2 = randn(1,5)
z2 =
 -0.1894 -1.4426 -0.3592 0.8883 -0.4337
```

`z2` contains exactly the same values as `z1`.

### Example 2

Return `rand`, `randi`, and `randn` to their default startup settings:

```
s = RandStream('mt19937ar','Seed',0)
RandStream.setGlobalStream(s);
```

### Example 3

Replace the current global random number stream with a stream whose seed is based on the current time, so `rand`, `randi`, and `randn` will return different values in different MATLAB sessions. It is usually not desirable to do this more than once per MATLAB session as it may affect the statistical properties of the random numbers MATLAB produces:

```
s = RandStream('mt19937ar','Seed','shuffle');
RandStream.setGlobalStream(s);
```

## Tips

- Streams created using `RandStream` might not be independent from each other. Use `RandStream.create` to create multiple streams that are independent.

# RandStream constructor

---

## See Also

`RandStream` | `RandStream.rand` | `RandStream.randn` |  
`RandStream.randi` | `RandStream.getGlobalStream` |  
`RandStream.setGlobalStream` | `RandStream.list` | `rng` |  
`RandStream.create`

**Purpose** Current global random number stream

**Class** @RandStream

**Syntax** `stream = RandStream.getGlobalStream`

**Description** `stream = RandStream.getGlobalStream` returns the current global random number stream.

`rand`, `randi`, and `randn` all rely on the same stream of uniform pseudorandom numbers, known as the *global stream*. `rand` draws one value from that stream to generate each uniform value it returns. `randi` draws one uniform value from that stream to generate each integer value it returns. And `randn` draws one or more uniform values to generate each normal value it returns. Note that there are also `rand`, `randi`, and `randn` methods for which you specify a specific random stream from which to draw values.

---

**Note** The `rng` function is a shorter alternative for many common uses of `RandStream.getGlobalStream`.

---

**See Also** `RandStream` | `rng` | `RandStream.setGlobalStream` | `rand` | `randi` | `randn`

**Concepts**

- “Creating and Controlling a Random Number Stream”
- “Managing the Global Stream”

# RandStream.setGlobalStream

---

**Purpose** Set global random number stream

**Syntax** `prevstream = RandStream.setGlobalStream(stream)`

**Description** `prevstream = RandStream.setGlobalStream(stream)` designates the random number stream, specified as `stream`, to be the global stream that the `rand`, `randi`, and `randn` functions draw values from. It returns the previous global random number stream as `prevstream`.

`rand`, `randi`, and `randn` all rely on the same stream of uniform pseudorandom numbers, known as the *global stream*. `rand` draws one value from that stream to generate each uniform value it returns. `randi` draws one uniform value from that stream to generate each integer value it returns. And `randn` draws one or more uniform values to generate each normal value it returns. Note that there are also `rand`, `randi`, and `randn` methods for which you specify a specific random stream from which to draw values.

---

**Note** The `rng` function is a shorter alternative for many common uses of `RandStream.setGlobalStream`.

---

**See Also** `RandStream` | `RandStream.getGlobalStream` | `rng` | `rand` | `randi` | `randn`

**Concepts**

- “Creating and Controlling a Random Number Stream”
- “Managing the Global Stream”

---

<b>Purpose</b>	Rank of matrix
<b>Syntax</b>	<code>k = rank(A)</code> <code>k = rank(A,tol)</code>
<b>Description</b>	<p>The rank function provides an estimate of the number of linearly independent rows or columns of a full matrix.</p> <p><code>k = rank(A)</code> returns the number of singular values of A that are larger than the default tolerance, <code>max(size(A))*eps(norm(A))</code>.</p> <p><code>k = rank(A,tol)</code> returns the number of singular values of A that are larger than <code>tol</code>.</p>
<b>Tips</b>	Use <code>sprank</code> to determine the structural rank of a sparse matrix.
<b>Algorithms</b>	<p>There are a number of ways to compute the rank of a matrix. MATLAB software uses the method based on the singular value decomposition, or SVD. The SVD algorithm is the most time consuming, but also the most reliable.</p> <p>The rank algorithm is</p> <pre>s = svd(A); tol = max(size(A))*eps(max(s)); r = sum(s &gt; tol);</pre>
<b>See Also</b>	<code>sprank</code>

# rat

---

**Purpose** Rational fraction approximation

**Syntax**  
`R = rat(X)`  
`R = rat(X,tol)`

`[N,D] = rat( ___ )`

**Description** `R = rat(X)` returns the rational fraction approximation of `X` to within the default tolerance,  $1e-6 \cdot \text{norm}(X(:), 1)$ . The approximation is a string containing the truncated continued fractional expansion.

`R = rat(X,tol)` approximates `X` to within the tolerance, `tol`.

`[N,D] = rat( ___ )` returns two arrays, `N` and `D`, such that `N./D` approximates `X`, using any of the above syntaxes.

## Input Arguments

### **X - Input array**

numeric array

Input array, specified as a numeric array of class `single` or `double`.

### **Data Types**

`single` | `double`

**Complex Number Support:** Yes

### **tol - Tolerance**

scalar

Tolerance, specified as a scalar. `N` and `D` approximate `X`, such that  $N./D - X < \text{tol}$ . The default tolerance is  $1e-6 \cdot \text{norm}(X(:), 1)$ .

## Output Arguments

### **R - Continued fraction**

string

Continued fraction, returned as a string. The accuracy of the rational approximation via continued fractions increases with the number of terms.

**N - Numerator**

numeric array

Numerator, returned as a numeric array. N./D approximates X.

**D - Denominator**

numeric array

Denominator, returned as a numeric array. N./D approximates X.

**Examples****Approximate Value of**

Approximate the value of  $\pi$  using a rational representation of the quantity pi.

The mathematical quantity  $\pi$  is not a rational number, but the quantity pi that approximates it is a rational number since all floating-point numbers are rational.

Find the rational representation of pi.

```
format rat
pi
```

```
ans =
```

```
355/113
```

The resulting expression is a string. You also can use `rats(pi)` to get the same answer.

Use `rat` to see the continued fractional expansion of pi.

```
R = rat(pi)
```

```
R =
```

```
3 + 1/(7 + 1/(16))
```

The resulting string is an approximation by continued fractional expansion. If you consider the first two terms of the expansion, you get

the approximation  $3 + \frac{1}{7} = \frac{22}{7}$ , which only agrees with pi to 2 decimals.

However, if you consider all three terms printed by rat, you can recover the value 355/113, which agrees with pi to 6 decimals.

$$3 + \frac{1}{7 + \frac{1}{16}} = \frac{355}{113}.$$

Specify a tolerance for additional accuracy in the approximation.

```
R = rat(pi,1e-7)
```

```
R =
```

```
3 + 1/(7 + 1/(16 + 1/(-294)))
```

The resulting approximation, 104348/33215, agrees with pi to 9 decimals.

### **Express Array Elements as Ratios**

Create a 4-by-4 matrix.

```
format short;
X = hilb(4)
```

```
X =
```

```
 1.0000 0.5000 0.3333 0.2500
 0.5000 0.3333 0.2500 0.2000
 0.3333 0.2500 0.2000 0.1667
 0.2500 0.2000 0.1667 0.1429
```

Express the elements of X as ratios of small integers using rat.



```
[N,D] = rat(X)
```

```
N =
```

```

1 1 1 1
1 1 1 1
1 1 1 1
1 1 1 1
```

```
D =
```

```

1 2 3 4
2 3 4 5
3 4 5 6
4 5 6 7
```

The two matrices, N and D, approximate X with  $N./D$ .

View the elements of X as ratios using `format rat`.

```
format rat
```

```
X
```

```
X =
```

```

1 1/2 1/3 1/4
1/2 1/3 1/4 1/5
1/3 1/4 1/5 1/6
1/4 1/5 1/6 1/7
```

In this form, it is clear that N contains the numerators of each fraction and D contains the denominators.

## Algorithms

Even though all floating-point numbers are rational numbers, it is sometimes desirable to approximate them by simple rational numbers, which are fractions whose numerator and denominator are

small integers. Rational approximations are generated by truncating continued fraction expansions.

The `rat` function approximates each element of `X` by a continued fraction of the form

$$\frac{N}{D} = D_1 + \frac{1}{D_2 + \frac{1}{\left( D_3 + \dots + \frac{1}{D_k} \right)}}$$

The  $D_s$  are obtained by repeatedly picking off the integer part and then taking the reciprocal of the fractional part. The accuracy of the approximation increases exponentially with the number of terms and is worst when  $X = \text{sqrt}(2)$ . For  $X = \text{sqrt}(2)$ , the error with  $k$  terms is about  $2.68 * (.173)^k$ , so each additional term increases the accuracy by less than one decimal digit. It takes 21 terms to get full floating-point accuracy.

## See Also

`rats` | `format`

**Purpose**

Rational output

**Syntax**

```
S = rats(X)
S = rats(X, strlen)
```

**Description**

`S = rats(X)` returns a string containing the rational approximations to the elements of `X` using the default string length of 13. The rational output is the same as that produced by `format rat`.

`rats` returns asterisks for elements that cannot be printed in the allotted space, but which are not negligible compared to the other elements in `X`.

`S = rats(X, strlen)` returns a string of length `strlen`. The rational approximation uses a tolerance that is inversely proportional to string length.

**Input Arguments****X - Input array**

numeric array

Input array, specified as a numeric array of class `single` or `double`.

**Data Types**

`single` | `double`

**strlen - String length**

positive integer

String length, specified as a positive integer. The default string length is 13, which allows for 6 elements in 78 spaces.

**Output Arguments****S - Rational output**

string

Rational output, returned as a string.

## Examples

### Rational Representation of Matrix

Create a 4-by-4 matrix.

```
format short
X = hilb(4)
```

X =

1.0000	0.5000	0.3333	0.2500
0.5000	0.3333	0.2500	0.2000
0.3333	0.2500	0.2000	0.1667
0.2500	0.2000	0.1667	0.1429

View the rational representation of the matrix using rats.

```
R = rats(X)
```

R =

1	1/2	1/3	1/4
1/2	1/3	1/4	1/5
1/3	1/4	1/5	1/6
1/4	1/5	1/6	1/7

The result is the same as using `format rat`.

### Adjust Output String Length

Find the rational representation of pi with the default string length and approximation tolerance.

```
rats(pi)
```

ans =

```
355/113
```

The result is the same as using `format rat`.

---

Adjust the string length of the output, which also adjusts the approximation tolerance.

```
rats(pi,20)

ans =

 104348/33215
```

The resulting rational approximation has greater accuracy. As the string length increases, the tolerance decreases.

Adjust the string length again to achieve greater accuracy.

```
rats(pi,25)

ans =

 1146408/364913
```

The resulting approximation agrees with pi to 10 decimal places.

## Algorithms

The format `rat` command uses the same internal algorithm, with the default `strlen`, as `rats`.

`rats` obtains rational approximations with  $[N,D] = \text{rat}(X, \text{tol})$ , where  $\text{tol}$  is  $\min(10^{-(\text{strlen}-1)/2} * \text{norm}(X(\text{isfinite}(X)), 1), .1)$ . Thus, the tolerance is inversely proportional to the string length, `strlen`.

## See Also

`rat` | `format`

# rbbox

---

**Purpose** Create rubberband box for area selection

**Syntax**

```
rbbox
rbbox(initialRect)
rbbox(initialRect, fixedPoint)
rbbox(initialRect, fixedPoint, stepSize)
finalRect = rbbox(...)
```

**Description** `rbbox` initializes and tracks a rubberband box in the current figure. It sets the initial rectangular size of the box to 0, anchors the box at the figure's `CurrentPoint`, and begins tracking from this point.

`rbbox(initialRect)` specifies the initial location and size of the rubberband box as `[x y width height]`, where `x` and `y` define the lower left corner, and `width` and `height` define the size. `initialRect` is in the units specified by the current figure's `Units` property, and measured from the lower left corner of the figure window. The corner of the box closest to the pointer position follows the pointer until `rbbox` receives a button-up event.

`rbbox(initialRect, fixedPoint)` specifies the corner of the box that remains fixed. All arguments are in the units specified by the current figure's `Units` property, and measured from the lower left corner of the figure window. `fixedPoint` is a two-element vector, `[x y]`. The tracking point is the corner diametrically opposite the anchored corner defined by `fixedPoint`.

`rbbox(initialRect, fixedPoint, stepSize)` specifies how frequently the rubberband box is updated. When the tracking point exceeds `stepSize` figure units, `rbbox` redraws the rubberband box. The default stepsize is 1.

`finalRect = rbbox(...)` returns a four-element vector, `[x y width height]`, where `x` and `y` are the `x` and `y` components of the lower left corner of the box, and `width` and `height` are the dimensions of the box.

**Tips**

rbbox is useful for defining and resizing a rectangular region:

- For box definition, `initialRect` is `[x y 0 0]`, where `(x,y)` is the figure's `CurrentPoint`.
- For box resizing, `initialRect` defines the rectangular region that you resize (e.g., a legend). `fixedPoint` is the corner diametrically opposite the tracking point.

rbbox returns immediately if a button is not currently pressed. Therefore, you use rbbox with `waitforbuttonpress` so that the mouse button is down when rbbox is called. rbbox returns when you release the mouse button.

**Examples**

Assuming the current view is `view(2)`, use the current axes' `CurrentPoint` property to determine the extent of the rectangle in dataspace units:

```
f = figure;
a = axes('Parent',f);
k = waitforbuttonpress;
point1 = get(a,'CurrentPoint'); % button down detected
finalRect = rbbox; % return figure units
point2 = get(a,'CurrentPoint'); % button up detected
point1 = point1(1,1:2); % extract x and y
point2 = point2(1,1:2);
p1 = min(point1,point2); % calculate locations
offset = abs(point1-point2); % and dimensions
x = [p1(1) p1(1)+offset(1) p1(1)+offset(1) p1(1) p1(1)];
y = [p1(2) p1(2) p1(2)+offset(2) p1(2)+offset(2) p1(2)];
hold on
axis manual
plot(x,y) % redraw in dataspace units
```

**See Also**

`axis` | `dragrect` | `waitforbuttonpress`

# rcond

---

<b>Purpose</b>	Reciprocal condition number
<b>Syntax</b>	<code>C = rcond(A)</code>
<b>Description</b>	<code>C = rcond(A)</code> returns an estimate for the reciprocal condition of A in 1-norm. If A is well conditioned, <code>rcond(A)</code> is near 1.0. If A is badly conditioned, <code>rcond(A)</code> is near 0.
<b>Input Arguments</b>	<b>A - Input matrix</b> square numeric matrix  Input matrix, specified as a square numeric matrix.  <b>Data Types</b> single   double
<b>Output Arguments</b>	<b>C - Reciprocal condition number</b> scalar  Reciprocal condition number, returned as a scalar. The data type of C is the same as A.  The reciprocal condition number is a scale-invariant measure of how close a given matrix is to the set of singular matrices. <ul style="list-style-type: none"><li>• If C is near 0, the matrix is nearly singular and badly conditioned.</li><li>• If C is near 1.0, the matrix is well conditioned.</li></ul>
<b>Examples</b>	<b>Sensitivity of Badly Conditioned Matrix</b>  Examine the sensitivity of a badly conditioned matrix.  A notable matrix that is symmetric and positive definite, but badly conditioned, is the Hilbert matrix. The elements of the Hilbert matrix are $H(i,j) = 1/(i + j - 1)$ .  Create a 10-by-10 Hilbert matrix.  <code>A = hilb(10);</code>



Find the reciprocal condition number of the matrix.

```
C = rcond(A)
```

```
C =
```

```
2.8286e-14
```

The reciprocal condition number is small, so  $A$  is badly conditioned.

The condition of  $A$  has an effect on the solutions of similar linear systems of equations. To see this, compare the solution of  $Ax = b$  to that of the perturbed system,  $Ax = b + 0.01$ .

Create a column vector of ones and solve  $Ax = b$ .

```
b = ones(10,1);
```

```
x = A\b;
```

Now change  $b$  by 0.01 and solve the perturbed system.

```
b1 = b + 0.01;
```

```
x1 = A\b1;
```

Compare the solutions,  $x$  and  $x1$ .

```
norm(x-x1)
```

```
ans =
```

```
1.1250e+05
```

Since  $A$  is badly conditioned, a small change in  $b$  produces a very large change (on the order of  $1e5$ ) in the solution to  $x = A \setminus b$ . The system is sensitive to perturbations.

### Find Condition of Identity Matrix

Examine why the reciprocal condition number is a more accurate measure of singularity than the determinant.

Create a 5-by-5 multiple of the identity matrix.

```
A = eye(5)*0.01;
```

This matrix is full rank and has five equal singular values, which you can confirm by calculating `svd(A)`.

Calculate the determinant of A.

```
det(A)
```

```
ans =
```

```
1.0000e-10
```

Although the determinant of the matrix is close to zero, A is actually very well conditioned and *not* close to being singular.

Calculate the reciprocal condition number of A.

```
rcond(A)
```

```
ans =
```

```
1
```

The matrix has a reciprocal condition number of 1 and is, therefore, very well conditioned. Use `rcond(A)` or `cond(A)` rather than `det(A)` to confirm singularity of a matrix.

## Tips

- `rcond` is a more efficient but less reliable method of estimating the condition of a matrix compared to the condition number, `cond`.

## See Also

`cond` | `condest` | `norm` | `normest` | `rank` | `svd`

<b>Purpose</b>	Right array division
<b>Syntax</b>	$x = A ./ B$ <code>x = rdivide(A,B)</code>
<b>Description</b>	<p><math>x = A ./ B</math> divides each element of <i>A</i> by the corresponding element of <i>B</i>. Inputs <i>A</i> and <i>B</i> must have the same size unless one is a scalar value. A scalar value is expanded into an array of the same size as the other input.</p> <p><code>x = rdivide(A,B)</code> is an alternative way to divide <i>A</i> by <i>B</i>, but is rarely used. It enables operator overloading for classes.</p>
<b>Input Arguments</b>	<p><b>A - Numerator</b> numeric array   sparse numeric array</p> <p>Numerator, specified as a full or sparse numeric array. If <i>B</i> is an integer data type, <i>A</i> must be the same integer type or a scalar double.</p> <p><b>Data Types</b> single   double   int8   int16   int32   int64   uint8   uint16   uint32   uint64</p> <p><b>Complex Number Support:</b> Yes</p> <p><b>B - Denominator</b> numeric array   sparse numeric array</p> <p>Denominator, specified as a full or sparse numeric array. If <i>A</i> is an integer data type, <i>B</i> must be the same integer type or a scalar double.</p> <p><b>Data Types</b> single   double   int8   int16   int32   int64   uint8   uint16   uint32   uint64</p> <p><b>Complex Number Support:</b> Yes</p>

# rdivide, ./

---

## Output Arguments

### x - Solution

numeric array | sparse numeric array

Solution, returned as a full or sparse numeric array. If either A or B is an integer data type, then x is that same integer data type.

## Examples

### Divide Two Numeric Arrays

Create two numeric arrays, A and B, and divide the second array, B, into the first, A.

```
A = [2 4 6 8; 3 5 7 9];
B = 10*ones(2,4);
x = A./B
```

x =

```
 0.2000 0.4000 0.6000 0.8000
 0.3000 0.5000 0.7000 0.9000
```

### Integer Division

Divide an int16 scalar value by each element of an int16 vector.

```
a = int16(10);
b = int16([3 4 6]);
x = a./b
```

x =

```
 3 3 2
```

MATLAB rounds the results when dividing integer data types.

### Divide Scalar by Array

Create an array and divide it into a scalar.

```
C = 5;
D = magic(3);
```

```
x = C./D
```

```
x =
```

```
 0.6250 5.0000 0.8333
 1.6667 1.0000 0.7143
 1.2500 0.5556 2.5000
```

When you specify a scalar value to be divided by an array, the scalar value expands into an array of the same size, then element-by-element division is performed.

## Tips

- When dividing integers, use `idivide` for more rounding options.
- MATLAB does not support complex integer division.

## See Also

`ldivide` | `mldivide` | `mrdivide` | `idivide`

# VideoReader.read

---

**Purpose** Read video frame data from file

**Syntax**

```
video = read(obj)
video = read(obj,index)
video = read(__,'native')
```

**Description**

`video = read(obj)` reads in all video frames from the file associated with `obj`. The `read` method returns a H-by-W-by-B-by-F matrix, `video`, where H is the image frame height, W is the image frame width, B is the number of bands in the image (for example, 3 for RGB), and F is the number of frames read.

`video = read(obj,index)` reads only the specified frames. `index` can be a single number or a two-element array representing an index range of the video stream.

`video = read(__,'native')` returns data in the format specified by the `VideoFormat` property, and can include any of the input arguments in the previous syntaxes.

## Input Arguments

### **obj**

Name of multimedia object created with `VideoReader`.

### **index**

Frames to read, where the first frame number is 1. Use `Inf` to represent the last frame of the file.

For example:

```
video = read(obj, 1); % first frame only
video = read(obj, [1 10]); % first 10 frames
video = read(obj, Inf); % last frame only
video = read(obj, [50 Inf]); % frame 50 thru end
```

MATLAB cannot determine the number of frames in a variable frame rate file until you read the last frame. If the requested *index* extends beyond the end of the file, `read` returns either a

warning or an error. For more information, see “Read Variable Frame Rate Video”.

**Default:** [1 Inf]

## Output Arguments

### video

Array of data representing video frames, returned in a format dependent on the VideoFormat property of obj. For most files, the data type and dimensions of video are as follows. Note that when the VideoFormat property of obj is 'Indexed', the data type and dimensions of video depend on whether you call read with the 'native' argument.

Value of obj.VideoFormat	Data Type of video	Dimensions of video	Description
'RGB24'	uint8	H-by-W-by-3-by-F	RGB24 image
'Grayscale', without specifying 'native'	uint8	H-by-W-by-1-by-F	Grayscale image
'Indexed', without specifying 'native'	uint8	H-by-W-by-3-by-F	RGB24 image
'Grayscale' or 'Indexed', specifying 'native'	struct	1-by-F	MATLAB movie, which is an array of frame structure arrays, each containing the fields cdata and colormap.

# VideoReader.read

---

H is the image frame height, W is the image frame width, and F is the number of frames read.

For Motion JPEG 2000 files, the data type and dimensions of video are as follows.

Value of obj.VideoFormat	Data Type of video	Dimensions of video	Description
'Mono8'	uint8	H-by-W-by-1-by-F	Mono image
'Mono8 Signed'	int8	H-by-W-by-1-by-F	Mono signed image
'Mono16'	uint16	H-by-W-by-1-by-F	Mono image
'Mono16 Signed'	int16	H-by-W-by-1-by-F	Mono signed image
'RGB24'	uint8	H-by-W-by-3-by-F	RGB24 image
'RGB24 Signed'	uint8	H-by-W-by-3-by-F	RGB24 signed image
'RGB48'	uint16	H-by-W-by-3-by-F	RGB48 image
'RGB48 Signed'	int16	H-by-W-by-3-by-F	RGB48 signed image

## Examples

### Read and Play Back Movie File

Read and play back the movie file xylophone.mp4.

```
xyloObj = VideoReader('xylophone.mp4');
```

```
nFrames = xyloObj.NumberOfFrames;
vidHeight = xyloObj.Height;
vidWidth = xyloObj.Width;
```

Preallocate the movie structure.

```
mov(1:nFrames) = ...
```



```
struct('cdata',zeros(vidHeight,vidWidth, 3,'uint8'),...
 'colormap',[]);
```

Read one frame at a time.

```
for k = 1 : nFrames
 mov(k).cdata = read(xyloObj,k);
end
```

Size a figure based on the video's width and height.

```
hf = figure;
set(hf, 'position', [150 150 vidWidth vidHeight])
```

Play back the movie once at the video's frame rate.

```
movie(hf, mov, 1, xyloObj.FrameRate);
```

## See Also

[movie](#) | [VideoReader](#)

## How To

- [“Read Video Files”](#)

# Tiff.read

---

**Purpose** Read entire image

**Syntax**  
`imageData = tiffobj.read()`  
`[Y,Cb,Cr] = tiffobj.read()`

**Description** `imageData = tiffobj.read()` reads the image data from the current image file directory (IFD) in the TIFF file associated with the `Tiff` object, `tiffobj`.

`[Y,Cb,Cr] = tiffobj.read()` reads the YCbCr component data from the current directory in the TIFF file. Depending upon the values of the `YCbCrSubSampling` tag, the size of the Cb and Cr channels might differ from the Y channel.

**Examples** Open a `Tiff` object and read data from the TIFF file:

```
t = Tiff('example.tif','r');
imageData = t.read();
t.close();
```

**See Also** `Tiff.write` | `imread`

**Tutorials**

- “Exporting Image Data and Metadata to TIFF Files”
- “Reading Image Data and Metadata from TIFF Files”

<b>Purpose</b>	Read data asynchronously from device
<b>Syntax</b>	<code>readasync(obj)</code> <code>readasync(obj, size)</code>
<b>Description</b>	<p><code>readasync(obj)</code> initiates an asynchronous read operation on the serial port object, <code>obj</code>.</p> <p><code>readasync(obj, size)</code> asynchronously reads, at most, the number of bytes given by <code>size</code>. If <code>size</code> is greater than the difference between the <code>InputBufferSize</code> property value and the <code>BytesAvailable</code> property value, an error is returned.</p>
<b>Tips</b>	<p>Before you can read data, you must connect <code>obj</code> to the device with the <code>open</code> function. A connected serial port object has a <code>Status</code> property value of <code>open</code>. An error is returned if you attempt to perform a read operation while <code>obj</code> is not connected to the device.</p> <p>Only use <code>readasync</code> to configure the <code>ReadAsyncMode</code> property to <code>manual</code>. <code>readasync</code> is ignored if used when <code>ReadAsyncMode</code> is <code>continuous</code>.</p> <p>The <code>TransferStatus</code> property indicates if an asynchronous read or write operation is in progress. You can write data while an asynchronous read is in progress because serial ports have separate read and write pins. You can stop asynchronous read and write operations with the <code>stopasync</code> function.</p> <p>You can monitor the amount of data stored in the input buffer with the <code>BytesAvailable</code> property. Additionally, you can use the <code>BytesAvailableFcn</code> property to execute a callback function when the terminator or the specified amount of data is read.</p> <p><b>Rules for Completing an Asynchronous Read Operation</b></p> <p>An asynchronous read operation with <code>readasync</code> completes when one of these conditions is met:</p> <ul style="list-style-type: none"><li>• The terminator specified by the <code>Terminator</code> property is read.</li><li>• The time specified by the <code>Timeout</code> property passes.</li></ul>

# readasync

---

- The specified number of bytes is read.
- The input buffer is filled (if size is not specified).

Because `readasync` checks for the terminator, this function can be slow. To increase speed, you might want to configure `ReadAsyncMode` to `continuous` and continuously return data to the input buffer as soon as it is available from the device.

## Examples

This example creates the serial port object `s` on a Windows platform. It connects `s` to a Tektronix TDS 210 oscilloscope, configures `s` to read data asynchronously only if `readasync` is issued, and configures the instrument to return the peak-to-peak value of the signal on channel 1.

```
s = serial('COM1');
fopen(s)
s.ReadAsyncMode = 'manual';
fprintf(s, 'Measurement:Meas1:Source CH1')
fprintf(s, 'Measurement:Meas1:Type Pk2Pk')
fprintf(s, 'Measurement:Meas1:Value?')
```

Begin reading data asynchronously from the instrument using `readasync`. When the read operation is complete, return the data to the MATLAB workspace using `fscanf`.

```
readasync(s)
s.BytesAvailable

ans =
 15

out = fscanf(s)

out =
2.03999999619E0

fclose(s)
```

## See Also

[fopen](#) | [stopasync](#) | [BytesAvailable](#) | [BytesAvailableFcn](#) | [ReadAsyncMode](#) | [Status](#) | [TransferStatus](#)

# Tiff.readEncodedStrip

---

**Purpose** Read data from specified strip

**Syntax**  
`stripData = tiffobj.readEncodedStrip(stripNumber)`  
`[Y,Cb,Cr] = tiffobj.readEncodedStrip(stripNumber)`

**Description** `stripData = tiffobj.readEncodedStrip(stripNumber)` reads data from the strip specified by `stripNumber`. Strip numbers are one-based numbers.

`[Y,Cb,Cr] = tiffobj.readEncodedStrip(stripNumber)` reads YCbCr component data from the specified strip. The size of the chrominance components Cb and Cr might differ from the size of the luminance component Y depending on the value of the YCbCrSubSampling tag.

`readEncodeStrip` clips the last strip, if the strip extends past the `ImageLength` boundary.

## Examples **Read a Strip**

Read the first strip in the second image of a TIFF file.

Create a Tiff object associated with the example file, `example.tif`, and make the second image the current directory.

```
t = Tiff('example.tif','r');
t.setDirectory(2);
```

Read the data in the first strip. Then, close the Tiff object.

```
data = t.readEncodedStrip(1);
t.close();
```

**References** This method corresponds to the `TIFFReadEncodedStrip` function in the LibTIFF C API. To use this method, you must be familiar with the TIFF specification and technical notes. View this documentation at [LibTIFF - TIFF Library and Utilities](#).

**See Also** `Tiff.readEncodedTile` | `Tiff.isTiled`

## **Tutorials**

- “Exporting Image Data and Metadata to TIFF Files”
- “Reading Image Data and Metadata from TIFF Files”

# Tiff.readEncodedTile

---

**Purpose** Read data from specified tile

**Syntax**  
`tileData = tiffobj.readEncodedTile(tileNumber)`  
`[Y,Cb,Cr] = tiffobj.readEncodedTile(tileNumber)`

**Description**  
`tileData = tiffobj.readEncodedTile(tileNumber)` reads data from the tile specified by `tileNumber`. Tile numbers are one-based numbers.  
`[Y,Cb,Cr] = tiffobj.readEncodedTile(tileNumber)` reads YCbCr component data from the specified tile. The size of the chrominance components Cb and Cr might differ from the size of the luminance component Y, depending on the value of the YCbCrSubSampling tag.  
`readEncodedTile` clips tiles on the last row or right-most column of an image if the tile extends past the `ImageLength` and `ImageLength` boundaries.

## Examples **Read a Tile**

Create a Tiff object associated with the example file, `example.tif`. Then, read the first tile of data.

```
t = Tiff('example.tif','r');
data = t.readEncodedTile(1);
t.close();
```

## References

This method corresponds to the `TIFFReadEncodedTile` function in the LibTIFF C API. To use this method, you must be familiar with the TIFF specification and technical notes. View this documentation at [LibTIFF - TIFF Library and Utilities](#).

**See Also** `Tiff.readEncodedStrip` | `Tiff.isTiled`

**Tutorials**

- “Exporting Image Data and Metadata to TIFF Files”
- “Reading Image Data and Metadata from TIFF Files”



<b>Purpose</b>	Read image using RGBA interface
<b>Syntax</b>	<code>[RGB,alpha] = readRGBAImage()</code>
<b>Description</b>	<p><code>[RGB,alpha] = readRGBAImage()</code> reads an entire image using the RGBA interface. <code>RGB</code> consists of an <code>m</code>-by-<code>n</code>-by-3 colormetric image, where <code>m</code> and <code>n</code> are the height and width of the tile, respectively. <code>alpha</code> is the associated alpha matting. If the image does not have associated alpha matting, then <code>alpha</code> is a matrix with all values set to 255 (transparent).</p> <p>The pixel values may be transformed depending upon the values of the following tags:</p> <ul style="list-style-type: none"><li><code>PhotometricInterpretation</code></li><li><code>BitsPerSample</code></li><li><code>SamplesPerPixel</code></li><li><code>Orientation</code></li><li><code>ExtraSamples</code></li><li><code>ColorMap</code></li></ul>
<b>Examples</b>	<p>Return all image data as RGB, with associated alpha matting.</p> <pre>t = Tiff('example.tif','r'); t.setDirectory(2); [RGB,A] = t.readRGBAImage(); t.close();</pre>
<b>References</b>	<p>This method corresponds to the <code>TIFFReadRGBAImage</code> function in the LibTIFF C API.</p> <p>To use this method, you must be familiar with LibTIFF version 4.0.0, as well as the TIFF specification and technical notes. View this documentation at <a href="#">LibTiff - TIFF Library and Utilities</a>.</p>
<b>See Also</b>	<code>Tiff.readRGBAStrip</code>   <code>Tiff.readRGBATile</code>   <code>Tiff.read</code>

# Tiff.readRGBAImage

---

## **Tutorials**

- “Exporting Image Data and Metadata to TIFF Files”
- “Reading Image Data and Metadata from TIFF Files”

<b>Purpose</b>	Read strip data using RGBA interface
<b>Syntax</b>	<code>[RGB,alpha] = readRGBAStrip(row)</code>
<b>Description</b>	<p><code>[RGB,alpha] = readRGBAStrip(row)</code> reads a strip using the RGBA interface. <code>row</code> is a one-based number of any row contained by the strip. RGB consists of an <code>m</code>-by-<code>n</code>-by-3 colormetric image, where <code>m</code> and <code>n</code> are the height and width of the strip, respectively. <code>alpha</code> is the associated alpha matting. If the image does not have associated alpha matting, then <code>alpha</code> is a matrix with all values set to 255 (transparent).</p> <p>The strip is clipped if the strip boundary extends past the end of the image.</p> <p>The pixel values may be transformed depending upon the values of the following tags:</p> <ul style="list-style-type: none"><li>PhotometricInterpretation</li><li>BitsPerSample</li><li>SamplesPerPixel</li><li>Orientation</li><li>ExtraSamples</li><li>ColorMap</li></ul>
<b>Examples</b>	<p>Open a Tiff object and read the strip of data that contains the first row, using the RGBA interface, from the example file, <code>example.tif</code></p> <pre>t = Tiff('example.tif', 'r'); t.setDirectory(2); [RGB,A] = t.readRGBAStrip(1); t.close();</pre>
<b>References</b>	This method corresponds to the <code>TIFFReadRGBAStrip</code> function in the LibTIFF C API.

# Tiff.readRGBAStrip

---

To use this method, you must be familiar with LibTIFF version 4.0.0, as well as the TIFF specification and technical notes. View this documentation at [LibTiff - TIFF Library and Utilities](#).

## See Also

`Tiff.readRGBATile` | `Tiff.readRGBAImage`

## Tutorials

- “Exporting Image Data and Metadata to TIFF Files”
- “Reading Image Data and Metadata from TIFF Files”

**Purpose** Read tile data using RGBA interface

**Syntax** `[RGB,alpha] = readRGBATile(row,col)`

**Description** `[RGB,alpha] = readRGBATile(row,col)` reads a tile using the RGBA interface. `row` and `col` are the one-based row and column numbers of any pixel in the requested tile. `RGB` consists of an `m`-by-`n`-by-3 colormetric image, where `m` and `n` are the height and width of the tile, respectively. `alpha` is the associated alpha matting. If the image does not have associated alpha matting, then `alpha` is a matrix with all values set to 255 (transparent).

The tile is clipped if the tile boundaries extend past the edges of the image.

The pixel values may be transformed depending upon the values of the following tags:

PhotometricInterpretation

BitsPerSample

SamplesPerPixel

Orientation

ExtraSamples

ColorMap

**Examples** Open a Tiff object and read the first tile using the RGBA interface.

```
t = Tiff('example.tif','r');
t.setDirectory(1);
[RGB,A] = t.readRGBATile(1,1);
t.close();
```

**References** This method corresponds to the `TIFFReadRGBATile` function in the LibTIFF C API.

# Tiff.readRGBATile

---

To use this method, you must be familiar with LibTIFF version 4.0.0, as well as the TIFF specification and technical notes. View this documentation at [LibTiff - TIFF Library and Utilities](#).

## See Also

`Tiff.readRGBAStrip` | `Tiff.readRGBAImage`

## Tutorials

- “Exporting Image Data and Metadata to TIFF Files”
- “Reading Image Data and Metadata from TIFF Files”

**Purpose** Convenience function for static .NET System.Delegate Remove method

**Syntax** `result = Remove(combinedDelegate, removedDelegate)`

**Description** `result = Remove(combinedDelegate, removedDelegate)` removes last instance of the removedDelegate delegate from the combinedDelegate delegate.

**Input Arguments**

**combinedDelegate**  
.NET System.Delegate object. The combined delegate from which to remove the removedDelegate delegate.

**removedDelegate**  
.NET System.Delegate object. The delegate to remove from the combinedDelegate delegate.

**Output Arguments**

**result**  
.NET System.Delegate object. A new delegate which is the same as the combinedDelegate delegate except without the last instance of the removedDelegate delegate.

**Alternatives** Use the static Remove method of the System.Delegate class.

**See Also** RemoveAll | Combine

**How To**

- “Combine and Remove .NET Delegates”

**Related Links**

- MSDN System.Delegate.Remove Method reference page

# RemoveAll

---

<b>Purpose</b>	Convenience function for static .NET System.Delegate RemoveAll method
<b>Syntax</b>	<code>result = RemoveAll(combinedDelegate, removedDelegate)</code>
<b>Description</b>	<code>result = RemoveAll(combinedDelegate, removedDelegate)</code> removes all instances of removedDelegate from combinedDelegate.
<b>Input Arguments</b>	<p><b>combinedDelegate</b> .NET System.Delegate object. The combined delegate from which to remove all instances of the removedDelegate delegate.</p> <p><b>removedDelegate</b> .NET System.Delegate object. The delegate to remove from the combinedDelegate delegate.</p>
<b>Output Arguments</b>	<p><b>result</b> .NET System.Delegate object. A new delegate which is the same as the combinedDelegate delegate except without all instances of the removedDelegate delegate.</p>
<b>Alternatives</b>	Use the static RemoveAll method of the System.Delegate class.
<b>See Also</b>	Remove   Combine
<b>How To</b>	<ul style="list-style-type: none"><li>• “Combine and Remove .NET Delegates”</li></ul>
<b>Related Links</b>	<ul style="list-style-type: none"><li>• MSDN System.Delegate.RemoveAll Method reference page</li></ul>



## Purpose

Create timeseries object

## Description

Time series are data vectors sampled over time, in order, often at regular intervals. They are distinguished from randomly sampled data that form the basis of many other data analyses. Time series represent the time-evolution of a dynamic population or process. The linear ordering of time series gives them a distinctive place in data analysis, with a specialized set of techniques. Time series analysis is concerned with:

- Identifying patterns
- Modeling patterns
- Forecasting values

## Construction

`ts = timeseries` creates an empty time-series object.

`ts = timeseries(tsname)` creates an empty time-series object using the name, `tsname`, for the time-series object. This name can differ from the time-series variable name.

`ts = timeseries(data)` creates the time-series object using the specified data.

`ts = timeseries(data,time)` creates the time-series object using the specified data and time.

`ts = timeseries(data,time,quality)` specifies quality in terms of codes defined by `QualityInfo.Code`.

`ts = timeseries(data,'Name',tsname)` creates the time-series object using the specified data and the name, `tsname`.

`ts = timeseries(data,time,'Name',tsname)` creates the time-series object using the specified data, time, and the name, `tsname`.

`ts = timeseries(data,time,quality,'Name',tsname)` uses the specified quality and the name, `tsname`.

## Input Arguments

### data

The time-series data, which can be an array of samples

### tsname

Time-series name specified as a string

**Default:** ''

### time

The time vector.

When time values are date strings, you must specify `Time` as a cell array of date strings. When the time vector contains duplicate values:

- Duplicated values must occupy contiguous elements.
- Time values must not be decreasing.

Interpolating time-series data using methods like `resample` and `synchronize` can produce different results depending on whether the input `timeseries` contains duplicate times.

**Default:** A time vector that ranges from 0 to N-1 with a 1-second interval, where N is the number of samples.

### quality

An integer vector with values -128 to 127 that specifies the quality in terms of codes defined by `QualityInfo.Code`

When `Quality` is a vector:

- `Quality` must have the same length as the time vector.
- Each `Quality` value applies to the corresponding data sample.

When `Quality` is an array:

- `Quality` must have the same size as the data array.
- Each `Quality` value applies to the corresponding data value of the `ts.data` array.

## Properties

### Data

Time-series data, where each data sample corresponds to a specific time

The data can be a scalar, a vector, or a multidimensional array. Either the first or last dimension of the data must align with `Time`.

By default, NaNs represent missing or unspecified data. Set the `TreatNaNasMissing` property to determine how missing data is treated in calculations.

#### Attributes:

Dependent	true
-----------	------

### DataInfo

Contains fields for storing contextual information about `Data`:

- `Unit` — String that specifies data units
- `Interpolation` — A `tsdata.interpolation` object that specifies the interpolation method for this `timeseries` object.

Fields of the `tsdata.interpolation` object include:

- `Fhandle` — Function handle to a user-defined interpolation function
- `Name` — String that specifies the name of the interpolation method. Predefined methods include `'linear'` and `'zoh'` (zero-order hold). `'linear'` is the default.
- `UserData` — Any user-defined information entered as a string

## Events

An array of `tsdata.event` objects that stores event information for this `timeseries` object.

You add events by using the `addevent` method. Fields of the `tsdata.event` object include the following:

- `EventData` — Any user-defined information about the event
- `Name` — String that specifies the name of the event
- `Time` — Time value when this event occurs, specified as a real number or a date string
- `Units` — Time units
- `StartDate` — A reference date specified in MATLAB date-string format. `StartDate` is empty when you have a numerical (non-date-string) time vector.

## IsTimeFirst

Logical value (`true` or `false`) specifies whether the time vector is aligned with the first or last dimension of the `Data` array. The value is `false` for 3-D and higher dimensional data and `true` otherwise.

- `true` — The first dimension of the data array is aligned with the time vector. For example, `ts = timeseries(rand(3,3),1:3);`
- `false` — The last dimension of the data array is aligned with the time vector. For example: `ts = timeseries(rand(3,4,5),1:5);`

## Attributes:

<code>Dependent</code>	<code>true</code>
<code>SetAccess</code>	<code>'protected'</code>

## Length

Length of the time vector in the `timeseries` object

**Attributes:**

Dependent	true
SetAccess	'protected'

**Name**

The `timeseries` object name entered as a string, `tsname`.

This name can differ from the name of the `timeseries` variable in the MATLAB workspace.

**Quality**

An integer vector or array containing values -128 to 127 that specify the quality in terms of codes defined by `QualityInfo.Code`.

When `Quality` is a vector, it must have the same length as the time vector. In this case, each `Quality` value applies to a corresponding data sample.

When `Quality` is an array, it must have the same size as the data array. In this case, each `Quality` value applies to the corresponding value of the data array.

**Attributes:**

Dependent	true
-----------	------

**QualityInfo**

Provides a lookup table that converts numerical `Quality` codes to readable descriptions.

`QualityInfo` fields include the following:

- **Code** — Integer vector containing values -128 to 127 that define the “dictionary” of quality codes. You can assign one of these integer values to each `Data` value by using the `Quality` property.

- **Description** — Cell vector of strings, where each element provides a readable description of the associated quality Code.
- **UserData** — Stores any additional user-defined information.

Lengths of Code and Description must match.

## **Time**

Array of time values.

When `TimeInfo.StartDate` is empty, the numerical `Time` values are measured relative to 0 in specified units. When `TimeInfo.StartDate` is defined, the time values are date strings measured relative to the `StartDate` in specified units.

The length of `Time` must be the same as either the first or the last dimension of `Data`. When the data contains three or more dimensions, the length of `Time` matches the size of the last data dimension. Otherwise, the length of `Time` matches the size of the first data dimension.

### **Attributes:**

Dependent	true
-----------	------

## **TimeInfo**

Uses the following fields for storing contextual information about `Time`:

- **Units** — Time units having any of following values: 'weeks', 'days', 'hours', 'minutes', 'seconds', 'milliseconds', 'microseconds', or 'nanoseconds'
- **Start** — Start time
- **End** — End time (read only)
- **Increment** — Interval between two subsequent time values
- **Length** — Length of the time vector (read only)

- **Format** — String defining the date string display format. See the MATLAB `datestr` function reference page for more information.
- **StartDate** — Date string defining the reference date. See the MATLAB `setabstime` function reference page for more information.
- **UserData** — Stores any additional user-defined information

### **TreatNaNasMissing**

Logical value that specifies how to treat NaN values in `Data`:

- **true** — (Default) Treats all NaN values as missing data except during statistical calculations.
- **false** — Includes NaN values in statistical calculations, in which case NaN values are propagated to the result.

### **UserData**

Generic field for data of any class that you want to add to the object.

**Default:** []

## **Methods**

### **Time-Series Methods**

- [Methods to Query and Set Object Properties and Plot the Data on page 5702](#)
- [Methods to Manipulate Data and Time on page 5702](#)
- [Event Methods on page 5703](#)
- [Methods to Arithmetically Combine `timeseries` Objects on page 5704](#)
- [Methods to Calculate Descriptive Statistics for a `timeseries` Object on page 5705](#)

## Methods to Query and Set Object Properties and Plot the Data

<code>get</code>	Query <code>timeseries</code> object property values.
<code>getdatasamplesize</code>	Return the size of each data sample in a <code>timeseries</code> object.
<code>getqualitydesc</code>	Return data quality descriptions based on the <code>Quality</code> property values assigned to a <code>timeseries</code> object.
<code>plot</code>	Plot the <code>timeseries</code> object.
<code>set</code>	Set <code>timeseries</code> property values.

## Methods to Manipulate Data and Time

<code>addsample</code>	Add a data sample to a <code>timeseries</code> object.
<code>append</code>	Concatenate <code>timeseries</code> objects in the time dimension.
<code>ctranspose</code>	Transpose a <code>timeseries</code> object.
<code>delsample</code>	Delete a sample from a <code>timeseries</code> object.
<code>detrend</code>	Subtract the mean or best-fit line and remove all NaNs from time-series data.
<code>filter</code>	Shape frequency content of time-series data using a 1-D digital filter.
<code>getabstime</code>	Extract a date-string time vector from a <code>timeseries</code> object into a cell array.
<code>getdatasamples</code>	Extract a subset of data samples from an existing <code>timeseries</code> object into an array using a subscripted indexed array.
<code>getsamples</code>	Extract a subset of data samples from an existing <code>timeseries</code> object into a new <code>timeseries</code> object using a subscript indexed array.



**(Continued)**

<code>getinterpmethod</code>	Get the interpolation method for a <code>timeseries</code> object.
<code>getsamplingsingtime</code>	Extract data samples from an existing <code>timeseries</code> object into a new <code>timeseries</code> object based on specified start and end time values.
<code>idealfilter</code>	Apply an ideal pass or notch (noncausal) filter to a <code>timeseries</code> object.
<code>resample</code>	Select or interpolate data in a <code>timeseries</code> object using a new time vector.
<code>setabstime</code>	Set the time values in the time vector as date strings.
<code>setinterpmethod</code>	Set interpolation method for a <code>timeseries</code> object.
<code>setuniformtime</code>	Assign uniform time vector to <code>timeseries</code> object.
<code>synchronize</code>	Synchronize and resample two <code>timeseries</code> objects using a common time vector.
<code>transpose</code>	Transpose a <code>timeseries</code> object.

**Event Methods**

To construct an event object, use the constructor `tsdata.event`. For an example of defining events for a time-series object, see “Defining Events”.

<code>addevent</code>	Add one or more events to a <code>timeseries</code> object.
<code>delevent</code>	Delete one or more events from a <code>timeseries</code> object.

## (Continued)

<code>gettsafteratevent</code>	Create a new <code>timeseries</code> object by extracting the samples from an existing time series that occur after or at a specified event.
<code>gettsafterevent</code>	Create a new <code>timeseries</code> object by extracting the samples that occur after a specified event from an existing time series.
<code>gettsatevent</code>	Create a new <code>timeseries</code> object by extracting the samples that occur at the same time as a specified event from an existing time series.
<code>gettsbeforeatevent</code>	Create a new <code>timeseries</code> object by extracting the samples that occur before or at a specified event from an existing time series.
<code>gettsbeforeevent</code>	Create a new <code>timeseries</code> object by extracting the samples that occur before a specified event from an existing time series.
<code>gettsbetweenevents</code>	Create a new <code>timeseries</code> object by extracting the samples that occur between two specified events from an existing time series.

## **Methods to Arithmetically Combine timeseries Objects**

<code>+</code>	Addition of the corresponding data values of <code>timeseries</code> objects.
<code>-</code>	Subtraction of the corresponding data values of <code>timeseries</code> objects.
<code>.*</code>	Element-by-element multiplication of <code>timeseries</code> data.

## (Continued)

<code>*</code>	Matrix-multiply <code>timeseries</code> data.
<code>./</code>	Right element-by-element division of <code>timeseries</code> data.
<code>/</code>	Right matrix division of <code>timeseries</code> data.
<code>.\</code>	Element-by-element left-array divide of <code>timeseries</code> data.
<code>\</code>	Left matrix division of <code>timeseries</code> data.

## Methods to Calculate Descriptive Statistics for a `timeseries` Object

<code>iqr</code>	Return the interquartile range of <code>timeseries</code> data.
<code>max</code>	Return the maximum value of <code>timeseries</code> data.
<code>mean</code>	Return the mean of <code>timeseries</code> data.
<code>median</code>	Return the median of <code>timeseries</code> data.
<code>min</code>	Return the minimum of <code>timeseries</code> data.
<code>std</code>	Return the standard deviation of <code>timeseries</code> data.
<code>sum</code>	Return the sum of <code>timeseries</code> data.
<code>var</code>	Return the variance of <code>timeseries</code> data.

## Definitions

### `timeseries`

The time-series object, called `timeseries`, is a MATLAB variable that contains time-indexed data and properties in a single, coherent structure. For example, in addition to data and time values, you can also use the time-series object to store events, descriptive information about data and time, data quality, and the interpolation method.

## Data Sample

A time-series *data sample* consists of one or more values recorded at a specific time. The number of data samples in a time series is the same as the length of the time vector.

For example, suppose that `ts.data` has the size 3-by-4-by-5 and the time vector has the length 5. Then, the number of samples is 5 and the total number of data values is  $3 \times 4 \times 5 = 60$ .

## Time Vector

A time vector of a `timeseries` object can be either numerical (double) values or valid MATLAB date strings.

When the `timeseries` `TimeInfo.StartDate` property is empty, the numerical time values are measured relative to 0 (or another numerical value) in specified units. In this case, the time vector is described as *relative* (that is, it contains time values that are not associated with a specific start date).

When `TimeInfo.StartDate` is nonempty, the time values are date strings measured relative to `StartDate` in specified units. In this case, the time vector is described as *absolute* (that is, it contains time values that are associated with a specific calendar date).

MATLAB supports the following date-string formats for time-series applications.

Date-String Format	Usage Example
dd-mmm-yyyy HH:MM:SS	01-Mar-2000 15:45:17
dd-mmm-yyyy	01-Mar-2000
mm/dd/yy	03/01/00
mm/dd	03/01
HH:MM:SS	15:45:17
HH:MM:SS PM	3:45:17 PM
HH:MM	15:45

Date-String Format	Usage Example
HH:MM PM	3:45 PM
mmm.dd,yyyy HH:MM:SS	Mar.01,2000 15:45:17
mmm.dd,yyyy	Mar.01,2000
mm/dd/yyyy	03/01/2000

## Copy Semantics

Value. To learn how value classes affect copy operations, see [Copying Objects in the MATLAB documentation](#).

## Examples

Create a `timeseries` object called 'LaunchData' that contains four data sets, each stored as a column of length 5 and using the default time vector:

```
b = timeseries(rand(5, 4), 'Name', 'LaunchData')
```

Create a `timeseries` object containing a single data set of length 5 and a time vector starting at 1 and ending at 5:

```
b = timeseries(rand(5,1), [1 2 3 4 5])
```

Create a `timeseries` object called 'FinancialData' containing five data points at a single time point:

```
b = timeseries(rand(1,5), 1, 'Name', 'FinancialData')
```

## See Also

[tscollection](#) | [tsdata.event](#)

## How To

- “MATLAB Objects”

# timeseries.addsample

---

**Purpose** Add data sample to timeseries object

**Syntax**

```
ts1 = addsample(ts, s)
ts1 = addsample(ts, 'Data', data-value,
 'Time', time-value, ..., Name,
 Value)
```

**Description** `ts1 = addsample(ts, s)` adds one or more new data samples stored in a structure `s` to the timeseries object `ts`.

`ts1 = addsample(ts, 'Data', data-value, 'Time', time-value, ..., Name, Value)` adds one or more data samples to the timeseries object `ts` along with additional options specified by one or more `Name, Value` pair arguments.

**Tips**

- If `N` is the number of data samples, you can get the sample size of each time with `SampleSize = getsamplesize(ts)`.

When `ts.IsTimeFirst` is true, the size of the data is `N-by-SampleSize`. When `ts.IsTimeFirst` is false, the size of the data is `SampleSize-by-N`.

## Input Arguments

**s**

A structure that you must define before passing as an argument to `addsample`. It consists of the following optional fields:

- `s.data`
- `s.time`
- `s.quality`
- `s.overwriteflag`

### **data-value**

A numeric data value.

### **time-value**

A valid time vector.

## **Name-Value Pair Arguments**

Specify optional comma-separated pairs of `Name`, `Value` arguments. `Name` is the argument name and `Value` is the corresponding value. `Name` must appear inside single quotes (' '). You can specify several name and value pair arguments in any order as `Name1,Value1,...,NameN,ValueN`.

### **'Quality'**

Array of data quality codes.

**Default:** []

### **'OverwriteFlag'**

Logical value that controls whether to overwrite a data sample at the same time with the new sample you are adding to your `timeseries` object. When set to `true`, the new sample overwrites the old sample at the same time.

**Default:** `false`

## **Output Arguments**

**ts1**

The `timeseries` object that results when you add the specified samples to the original `timeseries` object.

## **Definitions**

### **data sample**

One or more values recorded at a specific time. The number of data samples in a time series is the same as the length of the time vector.

## **Examples**

Add a data value of 420 at time 3:

```
ts = ts.addsample('Time',3,'Data',420);
```

---

# timeseries.addsample

---

Add a data value of 420 at time 3 and specify quality code 1 for this data value. Set the `OverwriteFlag` to overwrite an existing value at time 3.

```
ts = ts.addsample('Data',3.2,'Quality',1,'OverwriteFlag',...
 true,'Time',3);
```

## See Also

[timeseries](#) | [delsample](#) | [getdatasamples](#)



<b>Purpose</b>	Concatenate time series objects in time dimension
<b>Syntax</b>	<code>ts = append(ts1,ts2, ... tsn)</code>
<b>Description</b>	<code>ts = append(ts1,ts2, ... tsn)</code> creates a new <code>timeseries</code> object by concatenating <code>timeseries</code> <code>ts1</code> , <code>ts2</code> , and so on, along the time dimension.
<b>Tips</b>	<ul style="list-style-type: none"><li>• A single overlapping time between each input time series is valid, as long as the overlapping samples are identical.</li><li>• The time vectors must not overlap by a nonzero amount. That is, the last time in <code>ts1</code> must be earlier than or equal to the first time in <code>ts2</code>.</li><li>• The sample size of the time series must be the same.</li></ul>
<b>Input Arguments</b>	<p><b>ts1</b> The first <code>timeseries</code> object that you want to append.</p> <p><b>ts2</b> The second <code>timeseries</code> object that you want to append.</p> <p><b>tsn</b> The <code>n</code>th <code>timeseries</code> object that you want to append.</p>
<b>Output Arguments</b>	<p><b>ts</b> The <code>timeseries</code> object that results from appending the input <code>timeseries</code> objects.</p>
<b>Examples</b>	<p>After creating <code>timeseries</code> objects, <code>ts1</code> and <code>ts2</code>, append them:</p> <pre>ts1 = timeseries(rand(5,1),[1 2 3 4 5]); ts2 = timeseries(rand(5,1),[6 7 8 9 10]); ts3 = append(ts1, ts2)</pre>
<b>See Also</b>	<code>timeseries</code>

# timeseries.ctranspose

---

**Purpose** Transpose timeseries object

**Syntax** `ts1 = ctranspose(ts)`

**Description** `ts1 = ctranspose(ts)` returns a new timeseries object `ts1` with the `IsTimeFirst` value set to opposite of what it is for `ts`. For example, if `ts` has the first data dimension aligned with the time vector, `ts1` has the last data dimension aligned with the time vector as a result of this operation.

- Tips**
- The overloaded `ctranspose` method for timeseries objects does not transpose the data. Instead, this method changes whether the first or the last dimension of the data aligns with the time vector. To transpose the data, you must transpose the `Data` property of the timeseries object. For example, you can use the syntax `ctranspose(ts.Data)` or `(ts.Data)'`. The `Data` property value must be a 2-D array.
  - Consider a timeseries object with 10 samples with the property `IsTimeFirst = True`. When you transpose this object, the data size changes from 10-by-1 to 1-by-1-by-10. Note that the first dimension of the `Data` property is shown explicitly.

The following table summarizes the size for `Data` property of the timeseries object (up to three dimensions) before and after transposing.

## Data Size Before and After Transposing

Size of Original Data	Size of Transposed Data
N-by-1	1-by-1-by-N
N-by-M	M-by-1-by-N
N-by-M-by-L	M-by-L-by-N

## Input Arguments

**ts**

The timeseries object you want to transpose.

## Output Arguments

**ts1**

The transposed timeseries object.

## Examples

Suppose that a timeseries object `ts` has `ts.data` size 10-by-3-by-2 and its time vector has a length of 10. The `IsTimeFirst` property of `ts` is set to `true`, which means that the first dimension of the data is aligned with the time vector. `ctranspose(ts)` modifies `ts`, such that the last dimension of the data is now aligned with the time vector. This permutes the data, such that the size of `ts.Data` becomes 3-by-2-by-10.

## See Also

`timeseries` | `transpose`

# timeseries.delsample

---

**Purpose** Remove sample from timeseries object

**Syntax** `ts1 = delsample(ts,Name,Value)`

**Description** `ts1 = delsample(ts,Name,Value)` deletes samples from the timeseries object `ts` based on the specified `Name,Value` pair arguments.

**Input Arguments**

**ts**  
A timeseries object.

**Name-Value Pair Arguments** Specify optional comma-separated pairs of `Name,Value` arguments. `Name` is the argument name and `Value` is the corresponding value. `Name` must appear inside single quotes ( ' '). You can specify several name and value pair arguments in any order as `Name1,Value1,...,NameN,ValueN`.

**Index**

The indices of the time vector that correspond to the samples you want to delete.

**Value**

The time values that correspond to the samples you want to delete.

**Output Arguments**

**ts1**  
The timeseries object that results from removing the specified samples.

**Examples** Create a timeseries object, and then remove samples:

```
ts = timeseries(rand(5,1),[10 20 30 40 50]);

% Remove data sample at time index 1

ts1 = delsample(ts,'Index', 1)
```

```
% Remove data sample at time value 20:
ts2 = delsample(ts, 'Value', [20])
```

## See Also

set | timeseries

# timeseries.detrend

---

**Purpose** Subtract mean or best-fit line and all NaNs from `timeseries` object

**Syntax**

```
ts1 = detrend(ts, method)
ts1 = detrend(ts, method, index)
```

**Description** `ts1 = detrend(ts, method)` subtracts either a mean or a best-fit line from time-series data, using the specified `method`. Usually for FFT processing.

`ts1 = detrend(ts, method, index)` uses the optional `index` to specify the columns or rows to detrend.

**Tips**

- You cannot apply `detrend` to `timeseries` data with more than two dimensions.

**Input Arguments**

**ts**

The `timeseries` object from which you want to subtract the mean or best-fit line and all NaNs.

**method**

A string that specifies one of the following `detrend` methods:

- 'constant' — Subtracts the mean.
- 'linear' — Subtracts the best-fit line.

**index**

An integer array that specifies the columns or rows to detrend when `ts.IsTimeFirst` is true.

**Output Arguments**

**ts1**

The `timeseries` object resulting from detrending the input `timeseries` object.

**See Also** `timeseries`

**Purpose**

Shape frequency content of time-series

**Syntax**

```
ts1 = filter(ts, numerator, denominator)
ts1=filter(ts, numerator, denominator, index)
```

**Description**

`ts1 = filter(ts, numerator, denominator)` applies the transfer function filter  $b(z^{-1})/a(z^{-1})$  to the data in the timeseries object `ts`. `b` and `a` are the coefficient arrays of the transfer function numerator and denominator, respectively.

`ts1=filter(ts, numerator, denominator, index)` uses the optional `index` integer array to specify either the columns or rows to filter, depending on the value of `ts.IsTimeFirst`.

**Tips**

- The time-series data must be uniformly sampled to use this filter.
- The following function

```
y = filter(b,a,x)
```

creates filtered data `y` by processing the data in vector `x` with the filter described by vectors `a` and `b`.

- The `filter` function is a general tapped delay-line filter, described by the difference equation:

$$a(1)y(n) = b(1)x(n) + b(2)x(n - 1) + \dots + b(nb)x(n - nb + 1) - a(2)y(n - 1) - \dots - a(N_a)y(n - N_b + 1).$$

Here,  $n$  is the index of the current sample,  $N_a$  is the order of the polynomial described by vector `a`, and  $N_b$  is the order of the polynomial described by vector `b`. The output  $y(n)$  is a linear combination of current and previous inputs,  $x(n) x(n - 1)\dots$ , and previous outputs,  $y(n - 1) y(n - 2)\dots$ .

- You use the discrete filter to shape the data by applying a transfer function to the input signal.

# timeseries.filter

---

Depending on your objectives, the transfer function you choose might alter both the amplitude and the phase of the variations in the data at different frequencies to produce either a smoother or a rougher output.

- In digital signal processing (DSP), it is customary to write transfer functions as rational expressions in  $z^{-1}$  and to order the numerator and denominator terms in ascending powers of  $z^{-1}$ .

Taking the z-transform of the difference equation

$$a(1)y(n) = b(1)x(n) + b(2)x(n-1) + \dots + b(nb)x(n-nb+1) - a(2)y(n-1) - \dots - a(na)y(na+1),$$

results in the transfer function

$$Y(z) = H(z^{-1})X(z) = \frac{b(1) + b(2)z^{-1} + \dots + b(nb)z^{-nb+1}}{a(1) + a(2)z^{-1} + \dots + a(na)z^{-na+1}} X(z),$$

where  $Y(z)$  is the z-transform of the filtered output  $y(n)$ . The coefficients  $b$  and  $a$  are unchanged by the z-transform.

## Input Arguments

### **ts**

The first `timeseries` object for which you want to shape the frequency content.

### **numerator**

The coefficient array of the transfer function numerator.

### **denominator**

The coefficient array of the transfer function denominator.

### **index**

An integer array that specifies the columns or rows to filter when `ts.IsTimeFirst` is true.



**Output Arguments****ts1**

The timeseries object that results from filtering the input timeseries object.

**Examples****Apply Transfer Function to Time Series Data**

This example applies the following transfer function to the data in count.dat:

$$H(z^{-1}) = \frac{b(z^{-1})}{a(z^{-1})} = \frac{2 + 3z^{-1}}{1 + 0.2z^{-1}}$$

Load the matrix count into the workspace:

```
load count.dat;
```

Create a time-series object based on this matrix:

```
count1=timeseries(count(:,1),[1:24]);
```

Enter the coefficients of the denominator ordered in ascending powers of  $z^{-1}$  to represent  $1 + 0.2z^{-1}$ :

```
a = [1 0.2];
```

Enter the coefficients of the numerator to represent  $2 - 3z^{-1}$ :

```
b = [2 3];
```

Call the filter method:

```
filter_count = filter(count1, b, a);
```

Compare the original data and the shaped data with an overlaid plot of the two curves:

```
plot(count1,'-.'), grid on, hold on
plot(filter_count,'-')
```

# timeseries.filter

---

```
legend('Original Data','Shaped Data',2)
```

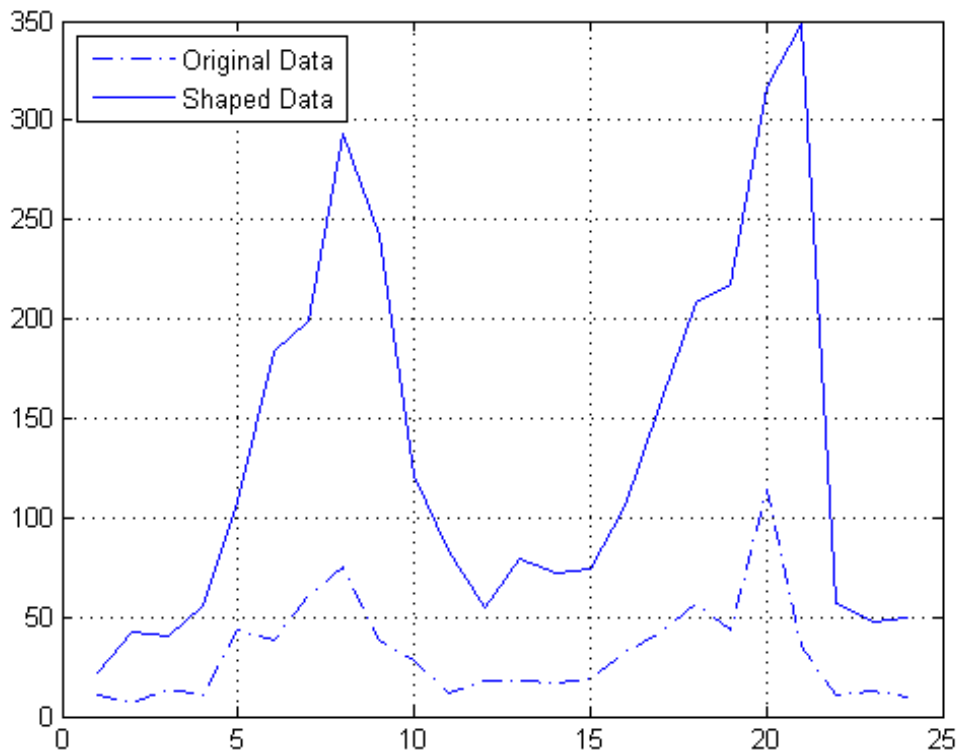

**See Also** [timeseries | idealfilter](#)

<b>Purpose</b>	Query <code>timeseries</code> object property values
<b>Syntax</b>	<pre>get(ts) value = get(ts, PropertyName)</pre>
<b>Description</b>	<p><code>get(ts)</code> displays all properties and values of the <code>timeseries</code> object, <code>ts</code>.</p> <p><code>value = get(ts, PropertyName)</code> returns the property value for the specified <code>timeseries</code> object. The following syntax is equivalent:</p> <pre>value = ts.PropertyName</pre>
<b>Input Arguments</b>	<p><b>ts</b> A <code>timeseries</code> object.</p> <p><b>PropertyName</b> String specifying the name of a <code>timeseries</code> property. For a list of <code>timeseries</code> properties, see <code>timeseries</code>.</p>
<b>Output Arguments</b>	<p><b>value</b> String containing the value associated with the specified property.</p>
<b>Examples</b>	<p>Create a <code>timeseries</code> object, and then get the name. This example gets the name three different ways:</p> <pre>ts1 = timeseries(rand(5,1),[1 2 3 4 5], 'Name', 'MyTimeseries'); get(ts1) get(ts1, 'Name') value = ts1.Name</pre>
<b>See Also</b>	<code>timeseries</code>   <code>set</code>

# timeseries.getabstime

---

**Purpose** Extract date-string time vector into cell array

**Syntax** `getabstime(ts)`

**Description** `getabstime(ts)` extracts the time vector from the `timeseries` object `ts` as a cell array of date strings.

**Tips**

- To define the time vector relative to a calendar date, set the `TimeInfo.StartDate` property of the `timeseries` object. When the `TimeInfo.StartDate` format is a valid `datestr` format, the output strings from `getabstime` have the same format.

**Input Arguments**

**ts**

The `timeseries` object from which you want to extract the time vector.

**Examples**

The following example extracts a time vector as a cell array of date strings from a `timeseries` object.

First, create a `timeseries` object.

```
ts = timeseries([3 6 8 0 10]);
```

The default time vector for `ts` is `[0 1 2 3 4]`, which starts at 0 and increases in 1-second increments. The length of the time vector is equal to the length of the data.

Next, set the `StartDate` property.

```
ts.TimeInfo.StartDate = '10/27/2005 07:05:36';
```

Extract the time vector.

```
getabstime(ts)
```

MATLAB returns:

```
'27-Oct-2005 07:05:36'
```

```
'27-Oct-2005 07:05:37'
'27-Oct-2005 07:05:38'
'27-Oct-2005 07:05:39'
'27-Oct-2005 07:05:40'
```

Change the date-string format of the time vector, and then extract the time vector with the new date-string format:

```
ts.TimeInfo.Format = 'mm/dd/yy';
getabstime(ts)
```

MATLAB returns:

```
'10/27/05'
'10/27/05'
'10/27/05'
'10/27/05'
'10/27/05'
```

## See Also

[timeseries](#) | [setabstime](#) | [datestr](#)

# timeseries.getdatasamples

---

**Purpose** Returns subset of time series samples using subscripted index array

**Syntax** `datasamples = getdatasamples(ts, i)`

**Description** `datasamples = getdatasamples(ts, i)` returns an array corresponding to the samples indicated by the array, `i`.

**Input Arguments**

**ts**  
The timeseries object from which you want to extract samples.

**i**  
An array of linear indices or logical values that specifies the time value or values for which you want to extract the corresponding samples.

**Output Arguments**

**datasamples**  
The array that results from extracting the samples corresponding to the time value or values, `ts.time(i)`.

**Examples**

After creating a timeseries object, `ts`, extract the second and third data samples into an array:

```
ts = timeseries(rand(5,1),[1 2 3 4 5]);
samples = getdatasamples(ts, [2 3])
```

**See Also**

`timeseries` | `getsamples` | `resample`

<b>Purpose</b>	Size of data sample in <code>timeseries</code> object
<b>Syntax</b>	<code>getdatasamplesize(ts)</code>
<b>Description</b>	<code>getdatasamplesize(ts)</code> returns the size of each data sample in a <code>timeseries</code> object.
<b>Input Arguments</b>	<b>ts</b> String specifying the name of a <code>timeseries</code> object.
<b>Definitions</b>	<b>data sample</b> One or more scalar values recorded at a specific time. The number of data samples is the same as the length of the time vector.
<b>Examples</b>	<p>After loading data and creating a <code>timeseries</code> object, get the size of a data sample:</p> <pre>% Load a 24-by-3 data array: load count.dat  % Create a timeseries object with 24 time values: count_ts = timeseries(count,[1:24], 'Name', 'VehicleCount')  % Get the size of the data sample for this timeseries object: getdatasamplesize(count_ts)</pre> <p>MATLAB returns the following, which indicates that the size of each data sample in <code>count_ts</code> is 1-by-3. In other words, MATLAB stores each data sample as a row with three values.</p> <pre>ans =       1     3</pre>
<b>See Also</b>	<code>timeseries</code>   <code>set</code>

# timeseries.getinterpmethod

---

**Purpose** Interpolation method for `timeseries` object

**Syntax** `getinterpmethod(ts)`

**Description** `getinterpmethod(ts)` returns the interpolation method that the `timeseries` object `ts`, uses as a string.

**Input Arguments** **ts**  
The `timeseries` object from which you want to extract the interpolation method.

**Definitions** **interpolation method**  
Predefined interpolation methods are zero-order hold, `zoh`, and linear interpolation, `linear`. Linear interpolation is the default.

**Examples** Create a `timeseries` object, and then get its interpolation method:

```
ts = timeseries(rand(5));
getinterpmethod(ts)
```

MATLAB returns:

```
linear
```

**See Also** `timeseries` | `setinterpmethod`



<b>Purpose</b>	Data quality descriptions
<b>Syntax</b>	<code>getqualitydesc(ts)</code>
<b>Description</b>	<code>getqualitydesc(ts)</code> returns a cell array of data quality descriptions based on the <code>Quality</code> values you assigned to a <code>timeseries</code> object, <code>ts</code> .
<b>Input Arguments</b>	<b>ts</b> A <code>timeseries</code> object.
<b>Examples</b>	<p>Create a <code>timeseries</code> object, and then get the data quality description strings for <code>ts</code>:</p> <pre>% Create a timeseries object, ts, with Data, Time, and Quality % values, respectively:  ts = timeseries([3; 4.2; 5; 6.1; 8], 1:5, [1; 0; 1; 0; 1]);  % Set the QualityInfo property, including Code and Description:  ts.QualityInfo.Code = [0 1]; ts.QualityInfo.Description = {'good' 'bad'};  % Get the data quality description strings for ts: getqualitydesc(ts)</pre> <p>MATLAB returns:</p> <pre>ans =      'bad'     'good'     'bad'     'good'     'bad'</pre>

# timeseries.getqualitydesc

---

## See Also

[timeseries](#)

<b>Purpose</b>	Subset of time series samples using subscripted index array
<b>Syntax</b>	<code>ts1 = getsamples(ts, i)</code>
<b>Description</b>	<code>ts1 = getsamples(ts, i)</code> returns a new <code>timeseries</code> object by extracting samples from <code>timeseries</code> <code>ts</code> corresponding to the time or times indicated by the subscripted index array, <code>i</code> .
<b>Input Arguments</b>	<p><b>ts</b></p> <p>The <code>timeseries</code> object from which you want to exact samples.</p> <p><b>i</b></p> <p>A subscripted index array that specifies the time value or values for which you want to extract the corresponding samples.</p>
<b>Output Arguments</b>	<p><b>ts1</b></p> <p>The <code>timeseries</code> object that results from extracting the samples corresponding to the time value or values <code>ts.time(i)</code> .</p>
<b>Examples</b>	<p>After creating a <code>timeseries</code> object, <code>ts</code>, extract the data samples at times 2 and 3 into a new <code>timeseries</code> object, <code>ts1</code>:</p> <pre>ts = timeseries(rand(5,1),[1 2 3 4 5]); ts1 = getdatasamples(ts, ts.time([2 3]))</pre>
<b>See Also</b>	<code>timeseries</code>   <code>getdatasamples</code>   <code>resample</code>

# timeseries.getsampleusingtime

---

**Purpose** Extract data samples into new timeseries object

**Syntax**  
`ts1 = getsampleusingtime(ts, time)`  
`ts1 = getsampleusingtime(ts, starttime, endtime)`

**Description**  
`ts1 = getsampleusingtime(ts, time)` returns a new timeseries object, `ts1`, with a single sample corresponding to specified `time` in `ts`.  
`ts1 = getsampleusingtime(ts, starttime, endtime)` returns a new timeseries object, `ts1`, with samples between the times `starttime` and `endtime` in `ts`.

**Tips**

- If the time vector in `ts` is not relative to a calendar date, then `starttime` and `endtime` must be numeric.
- If the time vector in `ts` is relative to a calendar date, then `starttime` and `endtime` values must be dates—either strings or `datetime` values.

**Input Arguments**

**ts**  
The timeseries object from which you want to extract data samples.

**time**  
The time corresponding to data sample you want to extract.

**starttime**  
The time corresponding to the first data sample you want to extract.

**endtime**  
The time corresponding to the last data sample you want to extract.

**Output Arguments**

**ts1**  
A timeseries object that contains the subset of data samples from the original timeseries object.

**See Also** [timeseries](#)

# timeseries.idealfilter

---

**Purpose** Apply ideal (noncausal) filter to timeseries object

**Syntax**  
`ts1 = idealfilter(ts, interval, filtertype)`  
`ts1 = idealfilter(ts, interval, filtertype, index)`

**Description** `ts1 = idealfilter(ts, interval, filtertype)` applies an ideal filter of `filtertype` to one or more frequency intervals that `interval` specifies for the timeseries object, `ts`.

`ts1 = idealfilter(ts, interval, filtertype, index)` applies an ideal filter and uses the optional `index` integer array to specify the columns or rows to filter.

- Tips**
- Ideal filters require data to have a mean of zero and prepare the data by subtracting its mean. You can restore the filtered signal amplitude by adding the mean of the input data to the filter output values.
  - Use the ideal *notch* filter when you want to remove variations in a specific frequency range. Alternatively, use the ideal *pass* filter to allow only the variations in a specific frequency range.
  - If the time-series data is sampled nonuniformly, filtering resamples this data on a uniform time vector.
  - All NaNs in the time series are interpolated before filtering, using the interpolation method you assigned to the timeseries object.

## Input Arguments

**ts**  
The timeseries object to which you want to apply an ideal filter.

**interval**  
The frequency interval (specified in cycles per time unit) at which you want the ideal filter applied. To specify several frequency intervals, use an n-by-2 array of start and end frequencies, where n represents the number of intervals.

**filtertype**

A string specifying the type of filter you want to apply, either pass or notch.

## index

An integer array that specifies the columns or rows to filter when `ts.IsTimeFirst` is true.

## Output Arguments

### ts1

The `timeseries` object that results when you apply an ideal filter to the original `timeseries` object.

## Definitions

### ideal filter

Filters are *ideal* in the sense that they are *not realizable*. An ideal filter is noncausal and the ends of the filter amplitude are perfectly flat in the frequency domain.

## Examples

### Apply Ideal Notch and Pass Filters

This example first applies an ideal notch filter to the data in `count.dat`. Then, it applies a pass filter to the data.

Load the count matrix into the workspace:

```
load count.dat;
```

Create a `timeseries` object from column one of this matrix. Specify a time vector that ranges from 1 to 24 s in 1-s intervals.

```
count1=timeseries(count(:,1),1:24);
```

Obtain the mean of the data:

```
countmean = mean(count1);
```

Enter the frequency interval, in hertz, for filtering the data:

```
interval=[0.08 0.2];
```

## timeseries.idealfilter

---

Invoke an ideal notch filter:

```
idealfilter_countn = idealfilter(count1, interval, 'notch');
```

Compare the original data and the shaped data on a line plot:

```
plot(count1, '-. '), grid on, hold on
plot(idealfilter_countn, '-')
```

Restore the mean to the filtered data and show it on the line plot, adding a legend and a title:

```
countn_restored = idealfilter_countn + countmean;
plot(countn_restored, ':');
title('Notch Filter')
legend('Original Data', 'Shaped Data', 'Mean Restored', ...
 'Location', 'NorthWest')
```



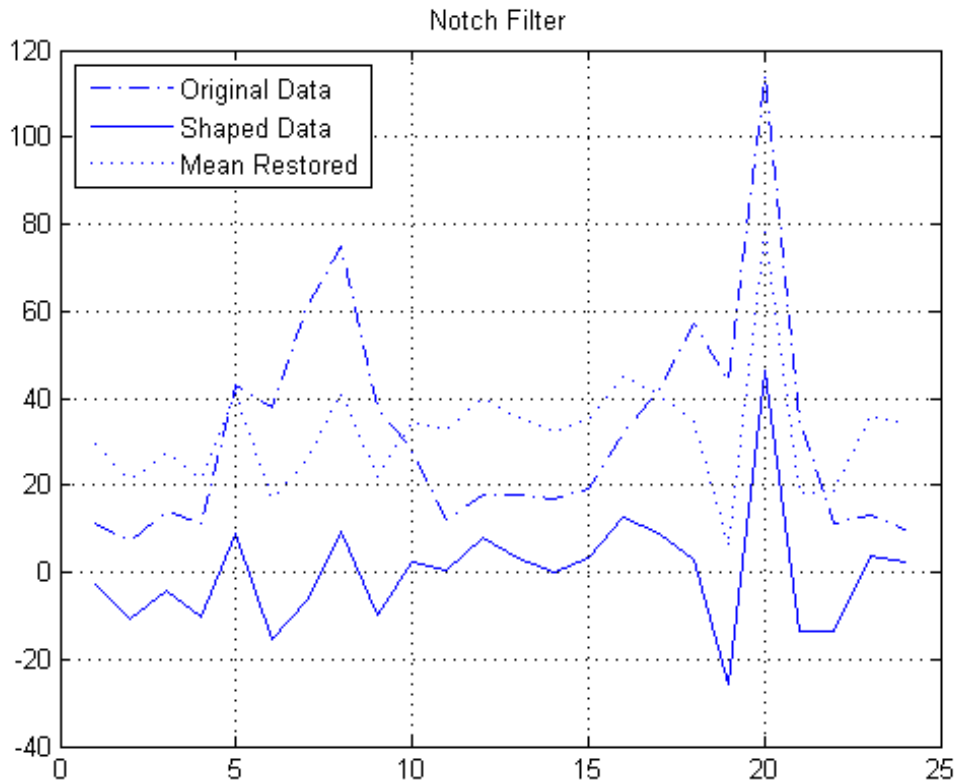

Close the Figure window:

```
close
```

Then, repeat the process using a pass rather than a notch filter:

```
figure
plot(count1,'-.'), grid on, hold on
idealfilter_countp = idealfilter(count1, interval, 'pass');
plot(idealfilter_countp, '-')
```

# timeseries.idealfilter

```
countp_restored = idealfilter_countp + countmean;
plot(countp_restored, ':');
title('Pass Filter')
legend('Original Data', 'Shaped Data', 'Mean Restored', ...
 'Location', 'NorthWest')
```

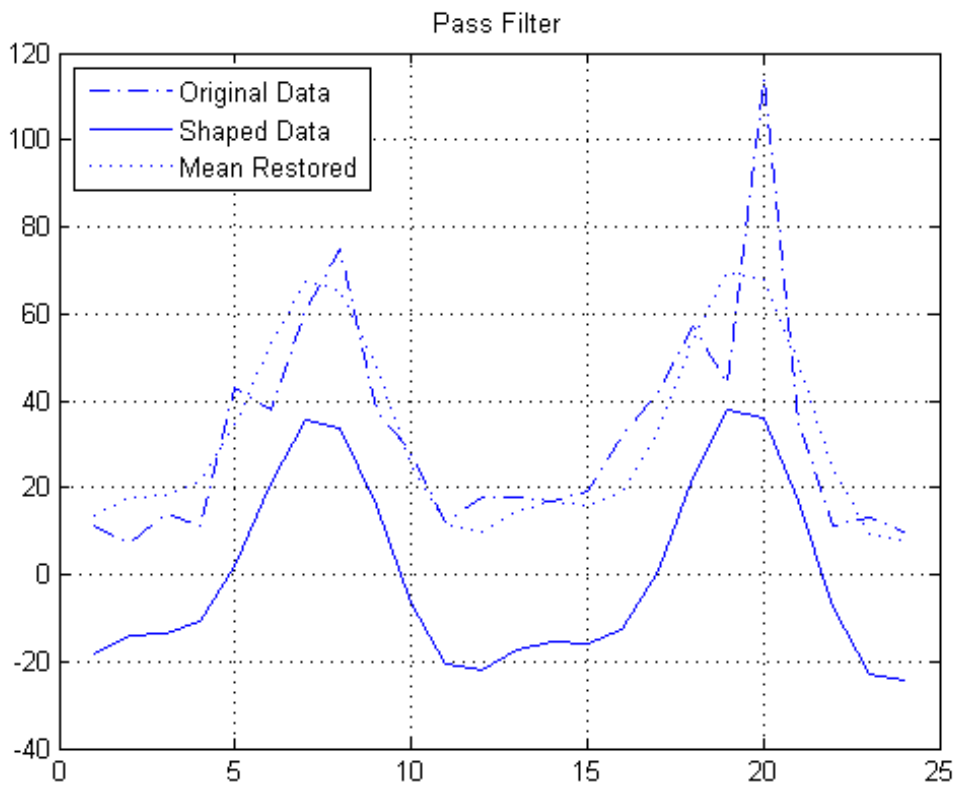

**See Also** [timeseries | filter](#)

<b>Purpose</b>	Interquartile range of <code>timeseries</code> data
<b>Syntax</b>	<pre>ts_iqr = iqr(ts) iqr(ts, Name, Value)</pre>
<b>Description</b>	<p><code>ts_iqr = iqr(ts)</code> returns the interquartile range of <code>ts.Data</code>.</p> <p><code>iqr(ts, Name, Value)</code> reruns the interquartile range of <code>ts.Data</code> with the specified <code>Name, Value</code> pairs.</p>
<b>Input Arguments</b>	<p><b>ts</b></p> <p>The <code>timeseries</code> object for which you want the interquartile range of <code>timeseries</code> data.</p> <p><b>Name-Value Pair Arguments</b></p> <p>Specify optional comma-separated pairs of <code>Name, Value</code> arguments. <code>Name</code> is the argument name and <code>Value</code> is the corresponding value. <code>Name</code> must appear inside single quotes ( ' '). You can specify several name and value pair arguments in any order as <code>Name1, Value1, ..., NameN, ValueN</code>.</p> <p><b>'MissingData'</b></p> <p>A string specifying one of two possible values, <code>remove</code> or <code>interpolate</code>, indicating how to treat missing data during the calculation.</p> <p><b>Default:</b> <code>remove</code></p> <p><b>'Quality'</b></p> <p>A vector of integers, indicating which quality codes represent missing samples (for vector data) or missing observations (for data arrays with two or more dimensions).</p>
<b>Output Arguments</b>	<p><b>ts_iqr</b></p> <p>The interquartile range of <code>ts.Data</code>, as follows:</p>

# timeseries.iqr

---

- When `ts.Data` is a vector, `ts_iqr` is the difference between the 75th and the 25th percentiles of the `ts.Data` values.
- When `ts.Data` is a matrix, and `IsTimeFirst` is `true`, and the first dimension of `ts` is aligned with time, then `ts_iqr` is a row vector containing the interquartile range of each column of `ts.Data`.

When `ts.Data` is an N-dimensional array, `iqr` always operates along the first nonsingleton dimension of `ts.Data`.

## Examples

Create a time series with a missing value, represented by `NaN`, and then calculate the interquartile range of `ts.Data` after removing the missing value from the calculation:

```
ts = timeseries([3.0 NaN 5 6.1 8], 1:5);
iqr(ts, 'MissingData', 'remove')
```

MATLAB returns:

```
3.0500
```

## See Also

`max` | `mean` | `median` | `min` | `std` | `sum` | `timeseries` | `var`

**Purpose** Maximum value of timeseries data

**Syntax**  
`ts_max = max(ts)`  
`ts_max = max(ts,Name,Value)`

**Description** `ts_max = max(ts)` returns the maximum value in the timeseries data.

`ts_max = max(ts,Name,Value)` returns the maximum value in the timeseries data with additional options specified by one or more `Name,Value` pair arguments.

**Input Arguments**

**ts**  
The timeseries object for which you want to determine the maximum data value.

**Name-Value Pair Arguments**

Specify optional comma-separated pairs of `Name,Value` arguments. `Name` is the argument name and `Value` is the corresponding value. `Name` must appear inside single quotes (' '). You can specify several name and value pair arguments in any order as `Name1,Value1,...,NameN,ValueN`.

**'MissingData'**

A string specifying one of two possible values, `remove` or `interpolate`, indicating how to treat missing data during the calculation.

**Default:** `remove`

**'Quality'**

A vector of integers, indicating which quality codes represent missing samples (for vector data) or missing observations (for data arrays with two or more dimensions).

# timeseries.max

---

## Output Arguments

### **ts\_max**

The maximum data value in the specified timeseries object, as follows:

- When `ts.Data` is a vector, `ts_max` is the maximum value of `ts.Data` values.
- When `ts.Data` is a matrix, `IsTimeFirst` is true, and the first dimension of `ts` is aligned with time, then `ts_max` is a row vector containing the maximum value of each column of `ts.Data`.

When `ts.Data` is an N-dimensional array, `max` always operates along the first nonsingleton dimension of `ts.Data`.

## Examples

The following example illustrates how to find the maximum values in multivariate time-series data:

```
% Load a 24-by-3 data array:
load count.dat

% Create a timeseries object with 24 time values:
count_ts = timeseries(count,[1:24], 'Name', 'CountPerSecond')

% Find the maximum in each data column for this timeseries object:

max(count_ts)
```

MATLAB returns:

```
114 145 257
```

## See Also

`iqr` | `mean` | `median` | `min` | `std` | `sum` | `timeseries` | `var`

**Purpose** Mean value of timeseries data

**Syntax**  
`ts_mn = mean(ts)`  
`ts_mn = mean(ts,Name,Value)`

**Description**  
`ts_mn = mean(ts)` returns the mean value of `ts.Data`.  
`ts_mn = mean(ts,Name,Value)` returns the mean value of `ts.Data` with additional options specified by one or more `Name,Value` pair arguments.

**Input Arguments**  
**ts**  
The timeseries object for which you want the mean value of data.

### **Name-Value Pair Arguments**

Specify optional comma-separated pairs of `Name,Value` arguments. `Name` is the argument name and `Value` is the corresponding value. `Name` must appear inside single quotes ( ' '). You can specify several name and value pair arguments in any order as `Name1,Value1,...,NameN,ValueN`.

#### **'MissingData'**

A string specifying one of two possible values, `remove` or `interpolate`, indicating how to treat missing data during the calculation.

**Default:** `remove`

#### **'Quality'**

A vector of integers, indicating which quality codes represent missing samples (for vector data) or missing observations (for data arrays with two or more dimensions).

#### **'Weighting'**

# timeseries.mean

---

A string specifying one of two possible values, `none` or `time`.  
When you specify `time`, larger time values correspond to larger weights.

## Output Arguments

**ts\_mn**

The mean value of `ts.Data`, as follows:

- When `ts.Data` is a vector, `ts_mn` is the mean value of `ts.Data` values.
- When `ts.Data` is a matrix, and `IsTimeFirst` is true and the first dimension of `ts` is aligned with time, then `ts_mn` is a row vector containing the mean value of each column of `ts.Data`.

When `ts.Data` is an N-dimensional array, `mean` always operates along the first nonsingleton dimension of `ts.Data`.

## Examples

Find the mean values in multivariate time-series data:

```
% Load a 24-by-3 data array:
```

```
load count.dat
```

```
% Create a timeseries object with 24 time values:
```

```
count_ts = timeseries(count,[1:24],'Name','CountPerSecond')
```

```
% Find the mean of each data column for this timeseries object:
```

```
mean(count_ts)
```

MATLAB returns:

```
32.0000 46.5417 65.5833
```



## Algorithms

MATLAB determines weighting by:

- 1 Attaching a weighting to each time value, depending on its order, as follows:
  - First time point — The duration of the first time interval ( $t(2) - t(1)$ ).
  - Time point that is neither the first nor last time point — The duration between the midpoint of the previous time interval to the midpoint of the subsequent time interval ( $(t(k + 1) - t(k))/2 + (t(k) - t(k - 1))/2$ ).
  - Last time point — The duration of the last time interval ( $(t(\text{end}) - t(\text{end} - 1))$ ).
- 2 Normalizing the weighting for each time by dividing each weighting by the mean of all weightings.

---

**Note** If the `timeseries` object is uniformly sampled, then the normalized weighting for each time is 1.0. Therefore, time weighting has no effect.

---

- 3 Multiplying the data for each time by its normalized weighting.

## See Also

`timeseries` | `timeseries.iqr` | `timeseries.max` |  
`timeseries.median` | `timeseries.min` | `timeseries.std` |  
`timeseries.sum` | `timeseries.var`

# timeseries.median

---

**Purpose** Median value of timeseries data

**Syntax**  
`ts_med = median(ts)`  
`ts_med = method(ts,Name,Value)`

**Description** `ts_med = median(ts)` returns the median value of `ts.Data`.  
`ts_med = method(ts,Name,Value)` returns the median value of `ts.Data` with additional options specified by one or more `Name,Value` pair arguments.

**Input Arguments** **ts**  
The timeseries object for which you want the median data value.

## **Name-Value Pair Arguments**

Specify optional comma-separated pairs of `Name,Value` arguments. `Name` is the argument name and `Value` is the corresponding value. `Name` must appear inside single quotes ( ' '). You can specify several name and value pair arguments in any order as `Name1,Value1,...,NameN,ValueN`.

### **'MissingData'**

A string specifying one of two possible values, `remove` or `interpolate`, indicating how to treat missing data during the calculation.

**Default:** `remove`

### **'Quality'**

A vector of integers, indicating which quality codes represent missing samples (for vector data) or missing observations (for data arrays with two or more dimensions).

### **'Weighting'**

A string specifying one of two possible values, `none` or `time`.  
When you specify `time`, larger time values correspond to larger weights.

## Output Arguments

### `ts_med`

The median value of `ts.Data`, as follows:

- When `ts.Data` is a vector, `ts_med` is the mean value of `ts.Data` values.
- When `ts.Data` is a matrix, and `IsTimeFirst` is `true`, and the first dimension of `ts` is aligned with time, then `ts_med` is a row vector containing the median value of each column of `ts.Data`.

When `ts.Data` is an N-dimensional array, `median` always operates along the first nonsingleton dimension of `ts.Data`.

## Examples

The following example finds the median values in multivariate time-series data. MATLAB finds the median independently for each data column in the `timeseries` object:

```
% Load a 24-by-3 data array:

load count.dat

% Create a timeseries object with 24 time values:

count_ts = timeseries(count,[1:24], 'Name', 'CountPerSecond');

% Find the median of each data column for this timeseries object:

median(count_ts)

MATLAB returns:

23.5000 36.0000 39.0000
```

## Algorithms

MATLAB determines weighting by:

- 1 Attaching a weighting to each time value, depending on its order, as follows:
  - First time point — The duration of the first time interval ( $t(2) - t(1)$ ).
  - Time point that is neither the first nor last time point — The duration between the midpoint of the previous time interval to the midpoint of the subsequent time interval ( $(t(k + 1) - t(k))/2 + (t(k) - t(k - 1))/2$ ).
  - Last time point — The duration of the last time interval ( $(t(\text{end}) - t(\text{end} - 1))$ ).
- 2 Normalizing the weighting for each time by dividing each weighting by the mean of all weightings.

---

**Note** If the `timeseries` object is uniformly sampled, then the normalized weighting for each time is 1.0. Therefore, time weighting has no effect.

---

- 3 Multiplying the data for each time by its normalized weighting.

## See Also

`iqr` | `max` | `mean` | `min` | `std` | `sum` | `timeseries` | `var`

<b>Purpose</b>	Minimum value of timeseries data
<b>Syntax</b>	<pre>ts_min = min(ts) ts_min = method(ts,Name,Value)</pre>
<b>Description</b>	<p><code>ts_min = min(ts)</code> returns the minimum value in the timeseries data.</p> <p><code>ts_min = method(ts,Name,Value)</code> uses additional options specified by one or more <code>Name,Value</code> pair arguments.</p>
<b>Input Arguments</b>	<p><b>ts</b></p> <p>The timeseries object for which you want the minimum data value.</p> <p><b>Name-Value Pair Arguments</b></p> <p>Specify optional comma-separated pairs of <code>Name,Value</code> arguments. <code>Name</code> is the argument name and <code>Value</code> is the corresponding value. <code>Name</code> must appear inside single quotes ( ' '). You can specify several name and value pair arguments in any order as <code>Name1,Value1,...,NameN,ValueN</code>.</p> <p><b>'MissingData'</b></p> <p>A string specifying one of two possible values, <code>remove</code> or <code>interpolate</code>, indicating how to treat missing data during the calculation.</p> <p><b>Default:</b> <code>remove</code></p> <p><b>'Quality'</b></p> <p>A vector of integers, indicating which quality codes represent missing samples (for vector data) or missing observations (for data arrays with two or more dimensions).</p>

# timeseries.min

---

## Output Arguments

### `ts_min`

The minimum value of `ts.Data`, as follows:

- When `ts.Data` is a vector, `ts_min` is the minimum value of `ts.Data` values.
- When `ts.Data` is a matrix, and `IsTimeFirst` is `true`, and the first dimension of `ts` is aligned with time, then `ts_min` is a row vector containing the minimum value of each column of `ts.Data`.

When `ts.Data` is an N-dimensional array, `min` always operates along the first nonsingleton dimension of `ts.Data`.

## Examples

The following example finds the minimum values in multivariate time-series data. MATLAB finds the minimum independently for each data column in the `timeseries` object.

```
% Load a 24-by-3 data array:
```

```
load count.dat
```

```
% Create a timeseries object with 24 time values:
```

```
count_ts = timeseries(count,[1:24],'Name','CountPerSecond');
```

```
% Find the minimum in each data column for this timeseries object:
```

```
min(count_ts)
```

```
MATLAB returns:
```

```
7 9 7
```

## See Also

`iqr` | `max` | `mean` | `median` | `std` | `sum` | `timeseries` | `var`

**Purpose**

Plot time series

**Syntax**

```
plot(ts)
plot(tsc.tsname)
plot(ts,linespec)
plot(tsc.tsname,linespec)
plot(ts,Name, Value)
plot(tsc.tsname,Name, Value)
```

**Description**

`plot(ts)` plots the timeseries data `ts` against time and interpolates values between samples by using either zero-order-hold ('zoh') or linear interpolation (the default). The plot displays in the current axes. MATLAB creates a title and axes, if none exists.

`plot(tsc.tsname)` plots the timeseries object, `tsname` that is part of the `tscollection`, `tsc`.

`plot(ts,linespec)` plots the timeseries data using a line graph and applies the specified `linespec` to lines, markers, or both.

`plot(tsc.tsname,linespec)` plots the timeseries object that is part of a timeseries collection as a line graph and applies the specified `linespec` to lines, markers, or both.

`plot(ts,Name, Value)` plots a line graph of the time series data using the values specified for `lineseries` properties.

`plot(tsc.tsname,Name, Value)` plots a line graph of the timeseries object that is part of the specified timeseries collection using the values specified for `lineseries` properties.

**Tips**

- The `timeseries/plot` method generates titles and axis labels automatically. These labels are:
  - Plot Title — 'Time Series Plot: <name>'  
where <name> is the string assigned to `ts.Name`, or by default, 'unnamed'
  - X-Axis Label — 'Time (<units>)'

# timeseries.plot

---

where `<units>` is the value of the `ts.TimeInfo.Units` field, which defaults to `'seconds'`

▪ Y-Axis Label — `'<name>'`

where `<name>` is the string assigned to `ts.Name`, or by default, `'unnamed'`

- You can place new time series data on a time series plot (by setting `hold on`, for example, and issuing another `timeseries/plot` command). When you add data to a plot, the title and axis labels become blank strings to avoid labeling confusion. You can add your own labels after plotting using the `title`, `xlabel`, and `ylabel` commands.
- Time series events, when defined, are marked in the plot with a circular marker with red fill. You can also specify markers for all data points using a `linespec` or `name/value` syntax in addition to any event markers your data defines. The event markers plot on top of the markers you define.
- The value assigned to `ts.DataInfo.Interpolation.Name` controls the type of interpolation the plot method uses when plotting and resampling time series data. Invoke the `timeseries` method `setinterpmethod` to change default linear interpolation to zero-order hold interpolation (staircase). This method creates a new `timeseries` object, with which you can overwrite the original one if you want. For example, to cause time series `ts` to use zero-order hold interpolation, type the following:

```
ts = ts.setinterpmethod('zoh');
```

## Input Arguments

**ts**  
A `timeseries` object.

**tsc**  
A `tscollection`.

**tsname**



The name of a timeseries object within the tscollection .

## Examples

### Plot Time Series Object with Specified Start Date

Create a time series object, set the start date, and then plot the time vector relative to the start date.

```
x = [2 5 8 2 11 3 6];
ts1 = timeseries(x,1:7);
ts1.Name = 'Daily Count';
ts1.TimeInfo.Units = 'days';
ts1.TimeInfo.StartDate='01-Jan-2011'; % Set start date.
ts1.TimeInfo.Format = 'mmm dd, yy'; % Set format for display on x-axis
ts1.Time=ts1.Time-ts1.Time(1); % Express time relative to the start date
plot(ts1)
```

# timeseries.plot

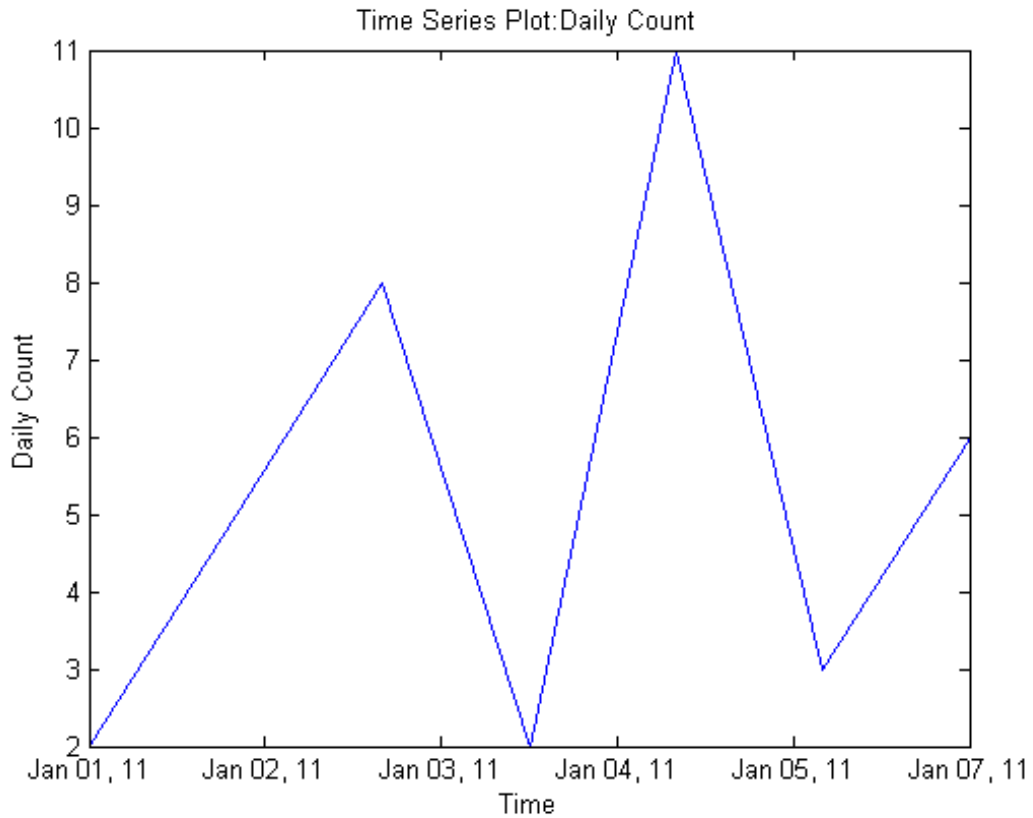

## Plot Two Time Series Objects on the Same Axes

Create two time series objects from traffic count data, and then plot them in sequence on the same axes. Add an event to one series, which is automatically displayed with a red marker.

```
load count.dat;
count1=timeseries(count(:,1),1:24);
count1.Name = 'Oak St. Traffic Count';
count1.TimeInfo.Units = 'hours';
```

```
plot(count1,':b'), grid on
```

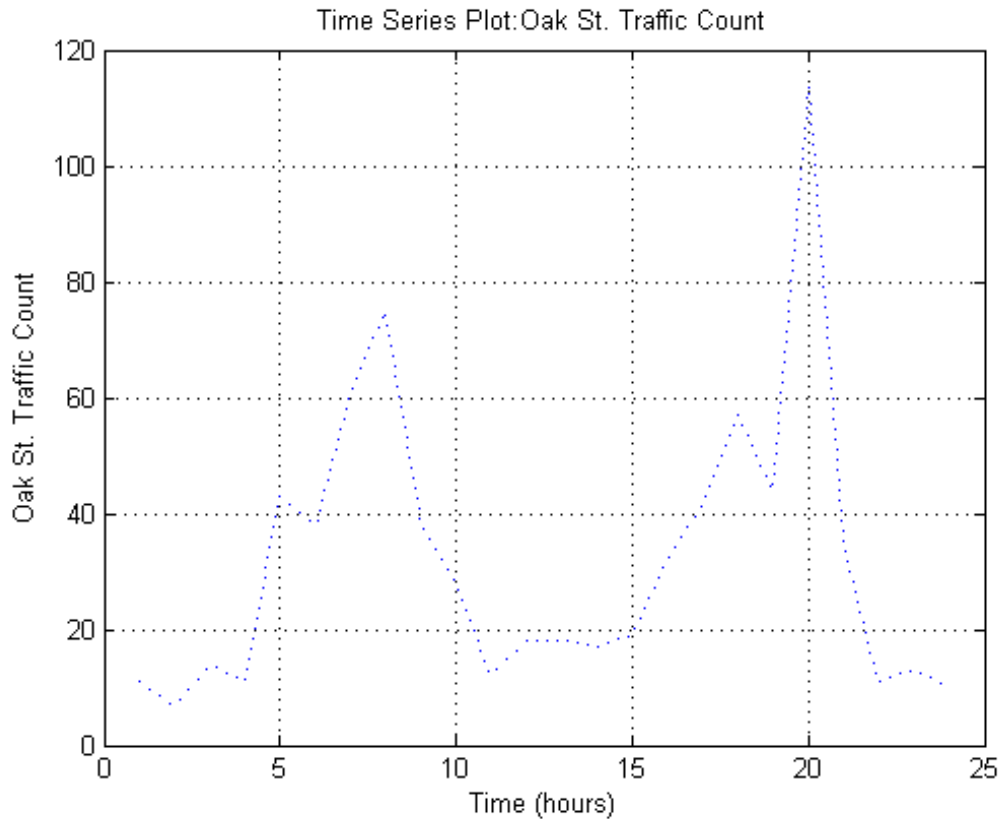

Obtain time of maximum value and add it as an event:

```
[~,index] = max(count1.Data);
max_event = tsdata.event('peak',count1.Time(index));
max_event.Units = 'hours';
```

Add the event to the time series:

# timeseries.plot

```
count1 = addevent(count1,max_event);
```

Replace plot with new one showing the event:

```
plot(count1,'.-b'), grid on
```

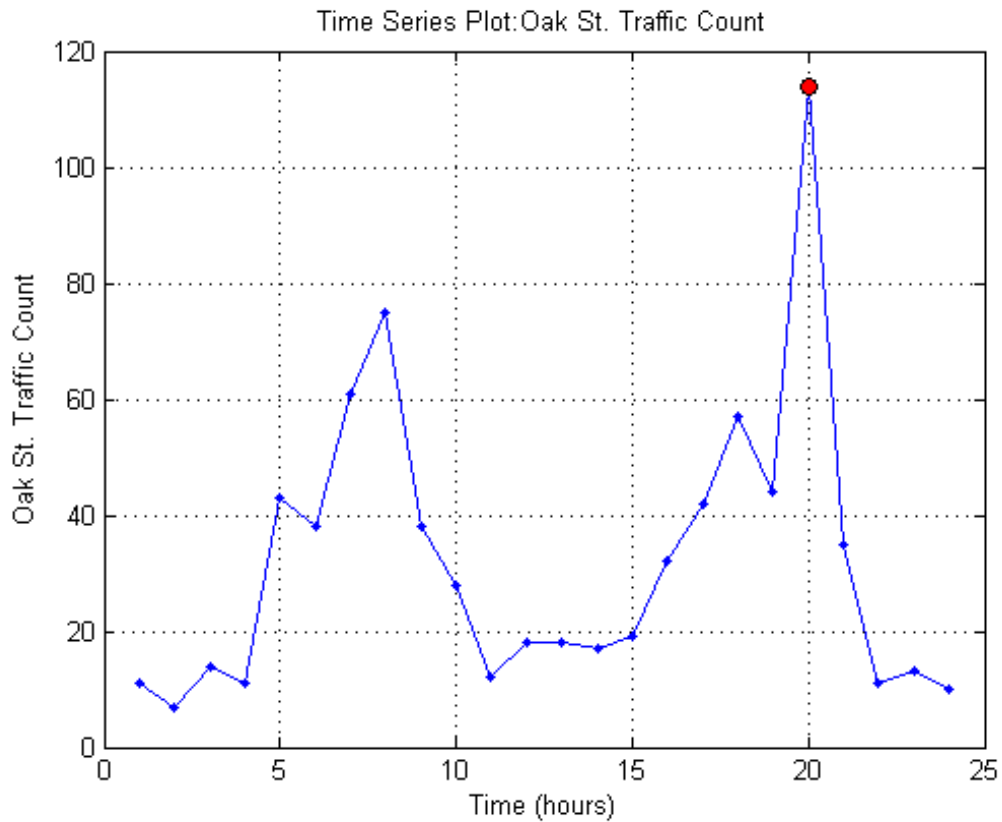

Make a new time series object from column 2 of the same data source:

```
count2=timeseries(count(:,2),1:24);
count2.Name = 'Maple St. Traffic Count';
```

```
count2.TimeInfo.Units = 'Hours';
```

Turn hold on to add the new data to the plot:

```
hold on
```

The plot method does not add labels to a held plot. Use property/value pairs to customize markers:

```
plot(count2, 's-m', 'MarkerSize', 6),
```

# timeseries.plot

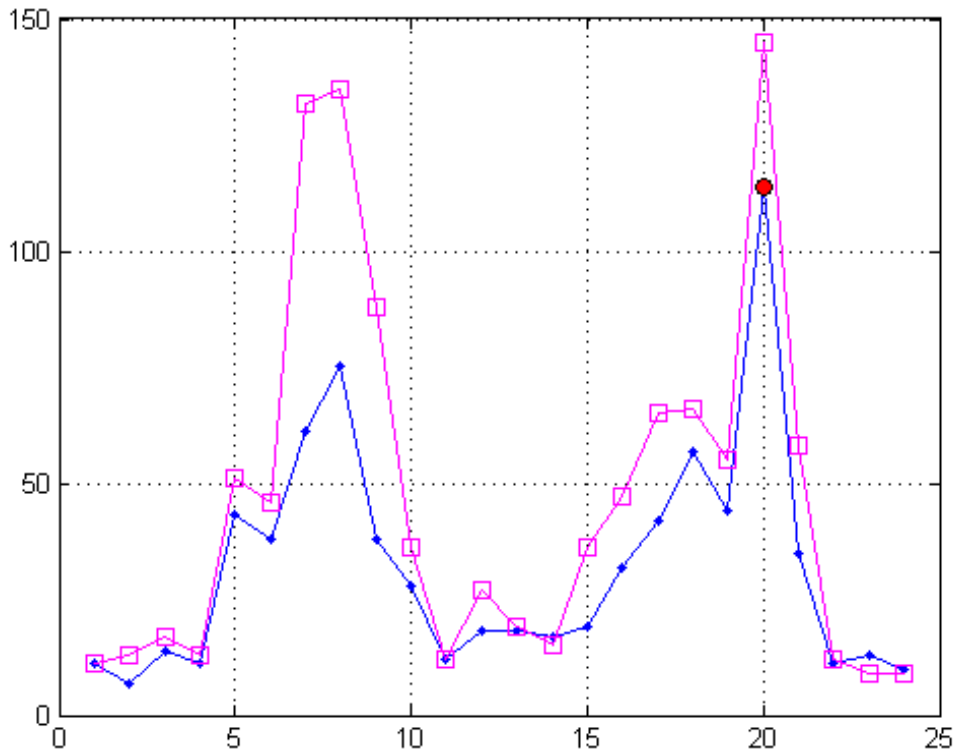

Labels are erased, so generate them manually:

```
title('Time Series: Oak Street and Maple Street')
xlabel('Hour of day')
ylabel('Vehicle count')
```

Add a legend in the upper left:

```
legend('Oak St.', 'Maple St.', 'Location', 'northwest')
```

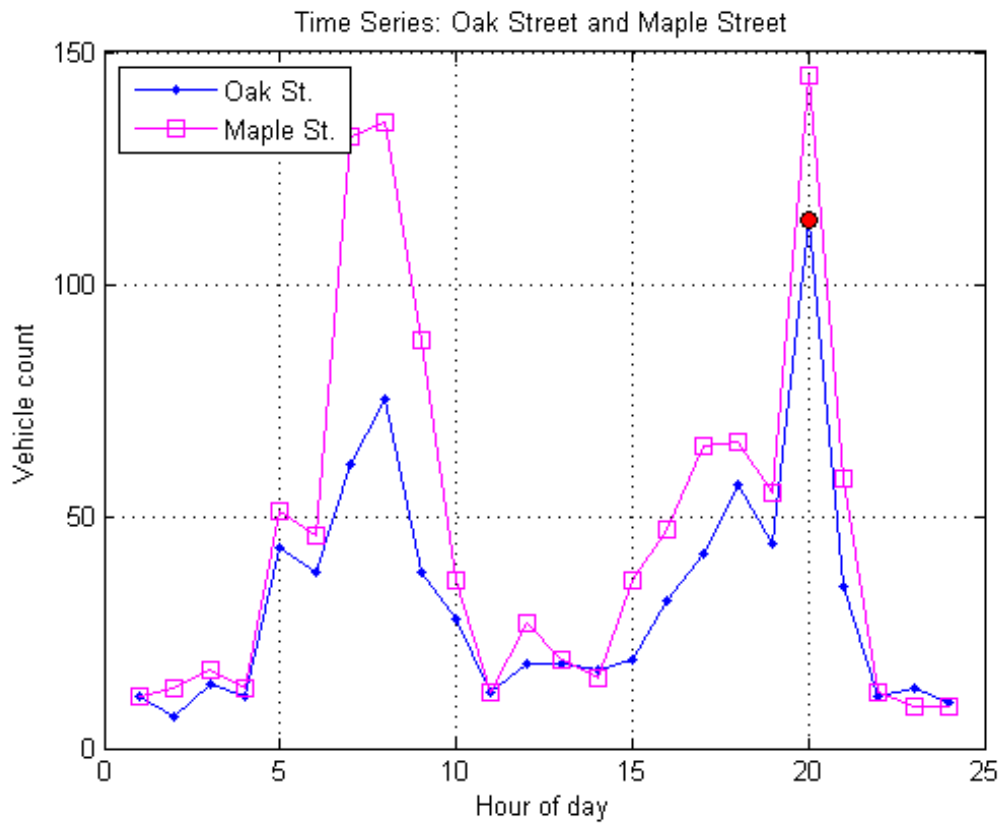
**See Also**

`timeseries` | `setinterpmethod` | `tscollection` | `tsdata.event`  
| `plot`

# timeseries.resample

---

**Purpose** Select or interpolate timeseries data using new time vector

**Syntax**

```
ts1 = resample(ts, time)
ts1 = resample(ts, time, interp_method)
ts1 = resample(ts, time, interp_method, code)
```

**Description** `ts1 = resample(ts, time)` resamples the timeseries object, `ts`, using the new `time` vector. The `resample` method uses the default interpolation method, which you can view by using the `getinterpmethod(ts)` syntax.

`ts1 = resample(ts, time, interp_method)` resamples the timeseries object `ts` using the specified interpolation method, `interp_method`.

`ts1 = resample(ts, time, interp_method, code)` resamples the timeseries object `ts` using the interpolation method given by the string `interp_method`. MATLAB applies the `code` to all samples.

## Input Arguments

**ts**  
The timeseries object that you want to resample.

**time**  
The time vector you want to use to resample the timeseries object.  
When `ts` uses date strings and `time` is numeric, then `time` is treated as specified relative to the `ts.TimeInfo.StartDate` property and in the same units that `ts` uses.

**interp\_method**  
A string specifying the interpolation method. Valid interpolation methods are `linear` and `zero-order hold, zoh`.

**Default:** `linear`

**code**



An integer value that specifies the user-defined Quality code for resampling. MATLAB applies this Quality code to all samples.

## Output Arguments

**ts1**

The `timeseries` object that results when you interpolate the original `timeseries` object with a new time vector.

## Examples

This example shows how to resample a `timeseries` object.

Create a `timeseries` object.

```
ts1 = timeseries([1.1; 2.9; 3.7; 4.0; 3.0],1:5,'Name','speed');
```

View the time, data, and interpolation method.

```
ts1.time
ts1.data
ts1.getinterpmethod
```

Resample `ts1` using its default interpolation method.

```
res_ts=resample(ts1,[1 1.5 3.5 4.5 4.9]);
```

View the time, data, and interpolation method for the resampled object.

```
res_ts.time
res_ts.data
res_ts.getinterpmethod
```

## See Also

`timeseries` | `getinterpmethod` | `setinterpmethod` | `synchronize`

# timeseries.set

---

**Purpose** Set properties of `timeseries` object

**Syntax**

```
set(ts, PropertyName, Value)
set(ts, PropertyName)
set(ts)
```

**Description** `set(ts, PropertyName, Value)` sets the named property, `Name`, of the `timeseries` object, `ts`, to the value, `Value`. The following syntax is equivalent:

```
ts.Property = Value
```

`set(ts, PropertyName)` displays the value of the named property for the `timeseries` object, `ts`.

`set(ts)` displays all properties and values of the `timeseries` object `ts`.

## Input Arguments

**ts**  
A `timeseries` object.

### PropertyName

A string specifying the name of a `timeseries` property. For a list of `timeseries` properties, see `timeseries`.

### Value

The value to which you want to set the named property.

## Examples

Create a `timeseries`, set its name to `mytimeseries`, and then view the `timeseries` properties:

```
ts1 = timeseries(rand(5,1),[1 2 3 4 5]);
set(ts1, 'Name', 'mytimeseries')
set(ts1)
```

## See Also

`timeseries` | `get`

<b>Purpose</b>	Set times of timeseries object as date strings
<b>Syntax</b>	<pre>ts1=setabstime(ts, times) ts1=setabstime(ts, times, format)</pre>
<b>Description</b>	<p><code>ts1=setabstime(ts, times)</code> sets the times in <code>ts</code> to the date strings specified in <code>times</code>.</p> <p><code>ts1=setabstime(ts, times, format)</code> explicitly specifies the date-string format, <code>format</code>, used in <code>times</code>.</p>
<b>Input Arguments</b>	<p><b>ts</b></p> <p>The timeseries object for which you want to set times as date strings.</p> <p><b>times</b></p> <p>A cell array of strings or a char array containing valid date or time values in the same date format.</p> <p><b>format</b></p> <p>The date-string format used for the time values.</p>
<b>Output Arguments</b>	<p><b>ts1</b></p> <p>The timeseries object that results from setting times as date strings on the original timeseries object.</p>
<b>Examples</b>	<p>Create a timeseries object, and then set the absolute time vector:</p> <pre>ts = timeseries(rand(3,1)) ts1 = setabstime(ts,{'12-DEC-2005 12:34:56',...     '12-DEC-2005 13:34:56','12-DEC-2005 14:34:56'})</pre> <p>% View each timeseries object in the Variable Editor to see the % differences in the time vectors for each.</p>
<b>See Also</b>	<code>datestr</code>   <code>getabstime</code>   <code>timeseries</code>

# timeseries.setinterpmethod

---

**Purpose** Set default interpolation method for timeseries object

**Syntax**

```
ts = setinterpmethod(ts, method)
ts = setinterpmethod(ts, fhandle)
ts = setinterpmethod(ts, interpobj)
```

**Description**

`ts = setinterpmethod(ts, method)` sets the default interpolation method, `method`, for timeseries object, `ts`, and outputs it to `ts1`.

`ts = setinterpmethod(ts, fhandle)` sets the default interpolation method for timeseries object `ts`, where `fhandle` is a function handle to the interpolation method.

`ts = setinterpmethod(ts, interpobj)` sets the default interpolation method for timeseries object `ts`, where `interpobj` is a `tsdata.interpolation` object that directly replaces the interpolation object stored in `ts`.

**Tips**

- This method is case sensitive.

## Input Arguments

**ts**

The timeseries object for which you want to set the default interpolation method.

### method

A string specifying the interpolation method. Valid values are `linear` and `zero-order hold, zoh`.

**Default:** `linear`

### fhandle

A function handle to the interpolation method. The order of input arguments defining the function handle must be `new_time`, `time`, and `data`. The single output argument must be the interpolated data only.

### interpobj

A `tsdata.interpolation` object a `tsdata.interpolation` object that directly replaces the interpolation object stored in `ts`.

## Output Arguments

**ts1**

The `timeseries` object that results when you set the interpolation method for the original `timeseries` object.

## Examples

Set the default interpolation method for `timeseries` object `ts` to zero order hold:

```
ts = timeseries(rand(100,1),1:100);
ts = setinterpmethod(ts,'zoh');
plot(ts);
```

Set the default interpolation method for `timeseries` object `ts`, where `fhandle` is a function handle to the interpolation method defined by function handle `myFuncHandle`:

```
ts = timeseries(rand(100,1),1:100);
myFuncHandle = @(new_time, time, data)...
 interp1(time, data, new_time,...
 'linear','extrap');
ts = setinterpmethod(ts, myFuncHandle);
ts = resample(ts, [-5:0.1:10]);
plot(ts);
```

Set the default interpolation method for `timeseries` object `ts` to a `tsdata.interpolation` object:

```
ts = timeseries(rand(100,1),1:100);
myFuncHandle = @(new_time, time, data)...
 interp1(time, data, new_time,...
 'linear','extrap');
myInterpObj = tsdata.interpolation(myFuncHandle);
ts = setinterpmethod(ts,myInterpObj);
plot(ts);
```

# timeseries.setinterpmethod

---

## See Also

`timeseries | getinterpmethod`

## Purpose

Modify uniform time vector of timeseries object

## Syntax

```
ts2 = setuniformtime(ts1,'StartTime',StartTime)
ts2 = setuniformtime(ts1,'Interval',Interval)
ts2 = setuniformtime(ts1,'EndTime',EndTime)
ts2 =
setuniformtime(ts1,'StartTime',StartTime,'Interval',Interval)
ts2 =
setuniformtime(ts1,'StartTime',StartTime,'EndTime',EndTime)
ts2 =
setuniformtime(ts1,'Interval',Interval,'EndTime',EndTime)
```

## Description

`ts2 = setuniformtime(ts1,'StartTime',StartTime)` returns the time series with a modified uniform time vector, determined from the `StartTime` and `Interval`. `EndTime = StartTime + (length(ts1) - 1)`. The unit of time is unchanged.

`ts2 = setuniformtime(ts1,'Interval',Interval)` sets the `StartTime` to 0, and uses `EndTime = (length(ts1) - 1)*Interval`.

`ts2 = setuniformtime(ts1,'EndTime',EndTime)` sets the `StartTime` to 0, and uses `Interval = EndTime/(length(ts1) - 1)`.

`ts2 = setuniformtime(ts1,'StartTime',StartTime,'Interval',Interval)` uses `EndTime = StartTime + (length(ts1) - 1) * Interval`.

`ts2 = setuniformtime(ts1,'StartTime',StartTime,'EndTime',EndTime)` uses `Interval = (EndTime - StartTime)/(length(ts1) - 1)`.

`ts2 = setuniformtime(ts1,'Interval',Interval,'EndTime',EndTime)` uses `StartTime = EndTime - (length(ts1) - 1) * Interval`.

## Input Arguments

### ts1

timeseries object to which you want to assign a uniform time vector.

# timeseries.setuniformtime

---

## StartTime

Start time of uniform time vector, specified as a numeric value.

## Interval

Time interval of uniform time vector, specified as a numeric scalar value.

## EndTime

End time of uniform time vector specified as a numeric scalar value.

## Output Arguments

### ts2

Time series with uniform time vector, returned as a `timeseries` object.

## Examples

### Specify New Start Time

Modify the uniform time vector of time series data by specifying a new start time.

- 1 Load the sample data.

```
load count.dat;
```

- 2 Create a `timeseries` object.

```
count_ts = timeseries(count,1:length(count),'Name','CountPerSecond');
```

- 3 Modify uniform time vector of `count_ts`.

```
count_ts = setuniformtime(count_ts,'StartTime',10);
```

The start time of the time vector is 10 seconds. `setuniformtime` uses a default time interval of 1 and computes the end time using:  $EndTime = StartTime + (length(count\_ts) - 1) * Interval$ .



## Specify New Start and End Times

Modify the uniform time vector of time series data by specifying a new start time and end time.

- 1 Load sample data.

```
load count.dat;
```

- 2 Create timeseries object.

```
count_ts = timeseries(count,1:length(count),'Name','CountPerSecond');
```

- 3 Assign a uniform time vector to count\_ts.

```
count_ts2 = setuniformtime(count_ts,'StartTime',10,'EndTime',20);
```

The start time of the time vector is now 10 seconds, and the end time is now 20 seconds. MATLAB computes the time interval using:  
$$\text{Interval} = (\text{EndTime} - \text{StartTime}) / (\text{length}(\text{count\_ts}) - 1)$$

## See Also

timeseries

# timeseries.synchronize

---

**Purpose** Synchronize and resample two `timeseries` objects using common time vector

**Syntax** `[ts1 ts2] = synchronize(ts1,ts2, synchronizemethod)`  
`[ts1 ts2] = synchronize(ts1,ts2, Name,Value)`

**Description** `[ts1 ts2] = synchronize(ts1,ts2, synchronizemethod)` creates two new `timeseries` objects by synchronizing `ts1` and `ts2` using a common time vector and the specified method.

`[ts1 ts2] = synchronize(ts1,ts2, Name,Value)` creates the two new `timeseries` objects with additional options specified by one or more `Name,Value` pair arguments.

## Input Arguments

### **ts1**

One of the `timeseries` objects that you want to synchronize and resample.

### **ts2**

The other `timeseries` object that you want to synchronize and resample.

### **synchronizemethod**

A string that defines the method for synchronizing the `timeseries` object. It can be any one of the following:

- **Union** — Resample `timeseries` objects using a time vector that is a union of the time vectors of `ts1` and `ts2` on the time range where the two time vectors overlap.
- **Intersection** — Resample `timeseries` objects on a time vector that is the intersection of the time vectors of `ts1` and `ts2`.
- **Uniform** — Requires an additional argument as follows:

```
[ts1 ts2] = synchronize(ts1,ts2,'Uniform','Interval',value)
```

This method resamples time series on a uniform time vector, where `value` specifies the time interval between two consecutive samples. The uniform time vector is the overlap of the time vectors of `ts1` and `ts2`. The interval units are the smaller units of `ts1` and `ts2`.

## **Name-Value Pair Arguments**

Specify optional comma-separated pairs of `Name`, `Value` arguments. `Name` is the argument name and `Value` is the corresponding value. `Name` must appear inside single quotes ( `' '` ). You can specify several name and value pair arguments in any order as `Name1, Value1, ..., NameN, ValueN`.

### **'InterpMethod'**

Forces the specified interpolation method (over the default method) for this synchronize operation. Can be either a string, `linear` or `zoh`, or a `tsdata.interpolation` object that contains a user-defined interpolation method.

**Default:** `linear`

### **'QualityCode'**

Integer (between -128 and 127) used as the quality code for both time series after the synchronization.

### **'KeepOriginalTimes'**

Logical value (`true` or `false`) indicating whether the new time series should keep the original time values.

### **'tolerance'**

Real number used as the tolerance for differentiating two time values when comparing the `ts1` and `ts2` time vectors. The default tolerance is `1e-10`. For example, when the sixth time value in `ts1` is `5+(1e-12)` and the sixth time value in `ts2` is `5-(1e-13)`, both values are treated as `5` by default. To differentiate those

# timeseries.synchronize

---

two times, you can set 'tolerance' to a smaller value such as 1e-15, for example.

## Output Arguments

**ts1**

One of the `timeseries` objects that you synchronized and resampled.

**ts2**

The other `timeseries` object that you synchronized and resampled.

## Examples

This example illustrates how the `KeepOriginalTime` property affects synchronization.

```
% Create two timeseries, such that ts1.timeinfo.StartDate
% is one day after ts2.timeinfo.StartDate:
```

```
ts1 = timeseries([1 2],[datestr(now); datestr(now+1)]);
ts2 = timeseries([1 2],[datestr(now-1); datestr(now)]);
```

```
% If you use this code, then ts1.timeinfo.StartDate
% is changed to match ts2.TimeInfo.StartDate
% and ts1.Time changes to 1:
```

```
[ts1 ts2] = synchronize(ts1,ts2,'union');
```

```
% But if you use this code, then ts1.timeinfo.StartDate
% is unchanged and ts1.Time is still 0:
```

```
[ts1 ts2] = synchronize(ts1,ts2,'union','KeepOriginalTimes',true);
```

## See Also

[set](#) | [timeseries](#)

**Purpose** Transpose timeseries object

**Syntax** `ts1 = transpose(ts)`

**Description** `ts1 = transpose(ts)` returns a new `timeseries` object, `ts1`, with `IsTimeFirst` value set to the opposite of what it is for `ts`. For example, if `ts` has the first data dimension aligned with the time vector, `ts1` has the last data dimension aligned with the time vector.

- Tips**
- The `transpose` function that is overloaded for `timeseries` objects does not transpose the data. Instead, this function changes whether the first or the last dimension of the data aligns with the time vector. To transpose the data, transpose the `Data` property of the time series. For example, you can use the syntax `transpose(ts.Data)` or `(ts.Data).'`. The value of the `Data` property must be a 2-D array.
  - Consider a time series with 10 samples with the property `IsTimeFirst = True`. When you transpose this time series, the data size changes from 10-by-1 to 1-by-1-by-10. Note that the first dimension of the `Data` property is shown explicitly.

The following table summarizes how the size for `timeseries` data (up to three dimensions) display before and after transposing.

### Data Size Before and After Transposing

Size of Original Data	Size of Transposed Data
N-by-1	1-by-1-by-N
N-by-M	M-by-1-by-N
N-by-M-by-L	M-by-L-by-N

### Input Arguments

**ts** The `timeseries` object that you want to transpose.

# timeseries.transpose

---

## Output Arguments

**ts1**

The `timeseries` object that is the result of transposing the original `timeseries` object.

## Examples

Suppose that a `timeseries` object, `ts`, has `ts.Data` size 10-by-3-by-2 and its time vector has a length of 10. The `IsTimeFirst` property of `ts` is `true`, which means that the first dimension of the data aligns with the time vector. `transpose(ts)` modifies the `timeseries` object, such that the last dimension of the data now aligns with the time vector. This permutes the data, such that the size of `ts.Data` becomes 3-by-2-by-10.

## See Also

`timeseries` | `transpose`

---

<b>Purpose</b>	Standard deviation of timeseries data
<b>Syntax</b>	<pre>ts_std = std(ts) ts_std = std(ts,Name,Value)</pre>
<b>Description</b>	<p><code>ts_std = std(ts)</code> returns the standard deviation of the timeseries data.</p> <p><code>ts_std = std(ts,Name,Value)</code> specifies additional options specified with one or more <code>Name,Value</code> pair arguments.</p>
<b>Input Arguments</b>	<p><b>ts</b></p> <p>The timeseries object for which you want the standard deviation of the data.</p> <p><b>Name-Value Pair Arguments</b></p> <p>Specify optional comma-separated pairs of <code>Name,Value</code> arguments. <code>Name</code> is the argument name and <code>Value</code> is the corresponding value. <code>Name</code> must appear inside single quotes ( ' '). You can specify several name and value pair arguments in any order as <code>Name1,Value1,...,NameN,ValueN</code>.</p> <p><b>'MissingData'</b></p> <p>A string specifying one of two possible values, <code>remove</code> or <code>interpolate</code>, indicating how to treat missing data during the calculation.</p> <p><b>Default:</b> <code>remove</code></p> <p><b>'Quality'</b></p> <p>A vector of integers, indicating which quality codes represent missing samples (for vector data) or missing observations (for data arrays with two or more dimensions).</p> <p><b>'Weighting'</b></p>

# timeseries.std

---

A string specifying one of two possible values, `none` or `time`.  
When you specify `time`, larger time values correspond to larger weights.

## Output Arguments

### `ts_std`

The standard deviation of `ts.Data` values as follows:

- When `ts.Data` is a vector, `ts_std` is the standard deviation of `ts.Data` values.
- When `ts.Data` is a matrix, and `IsTimeFirst` is `true`, and the first dimension of `ts` is aligned with time, then `ts_std` is the standard deviation of each column of `ts.Data`.

When `ts.Data` is an N-dimensional array, `std` always operates along the first nonsingleton dimension of `ts.Data`.

## Examples

The following example finds the standard deviation for a `timeseries` object. MATLAB calculates the standard deviation for each data column in the `timeseries` object.

```
% Load a 24-by-3 data array:
```

```
load count.dat
```

```
% Create a timeseries object with 24 time values:
```

```
count_ts = timeseries(count,1:24,'Name','CountPerSecond');
```

```
% Calculate the standard deviation of each data column for this
% timeseries object:
```

```
std(count_ts)
```

```
MATLAB returns:
```

```
25.3703 41.4057 68.0281
```



## Algorithms

MATLAB determines weighting by:

- 1 Attaching a weighting to each time value, depending on its order, as follows:
  - First time point — The duration of the first time interval ( $t(2) - t(1)$ ).
  - Time point that is neither the first nor last time point — The duration between the midpoint of the previous time interval to the midpoint of the subsequent time interval ( $(t(k + 1) - t(k))/2 + (t(k) - t(k - 1))/2$ ).
  - Last time point — The duration of the last time interval ( $(t(\text{end}) - t(\text{end} - 1))$ ).
- 2 Normalizing the weighting for each time by dividing each weighting by the mean of all weightings.

---

**Note** If the `timeseries` object is uniformly sampled, then the normalized weighting for each time is 1.0. Therefore, time weighting has no effect.

---

- 3 Multiplying the data for each time by its normalized weighting.

## See Also

`iqr` | `max` | `mean` | `median` | `min` | `sum` | `timeseries` | `var`

# timeseries.sum

---

**Purpose** Sum of timeseries data

**Syntax**  
`ts_sm = sum(ts)`  
`ts_sm = sum(ts,Name,Value)`

**Description** `ts_sm = sum(ts)` returns the sum of the timeseries data.  
`ts_sm = sum(ts,Name,Value)` specifies additional options with one or more `Name,Value` pair arguments.

**Input Arguments**

**ts**  
The timeseries object for which you want the sum of the data.

**Name-Value Pair Arguments**

Specify optional comma-separated pairs of `Name,Value` arguments. `Name` is the argument name and `Value` is the corresponding value. `Name` must appear inside single quotes ( ' '). You can specify several name and value pair arguments in any order as `Name1,Value1,...,NameN,ValueN`.

**'MissingData'**

A string specifying one of two possible values, `remove` or `interpolate`, indicating how to treat missing data during the calculation.

**Default:** `remove`

**'Quality'**

A vector of integers, indicating which quality codes represent missing samples (for vector data) or missing observations (for data arrays with two or more dimensions).

**'Weighting'**

A string specifying one of two possible values, `none` or `time`.  
When you specify `time`, larger time values correspond to larger weights.

## Output Arguments

### `ts_sm`

The sum of the `timeseries` data, as follows:

- When `ts.Data` is a vector, `ts_sm` is the sum of `ts.Data` values.
- When `ts.Data` is a matrix, and `IsTimeFirst` is `true`, and the first dimension of `ts` is aligned with time, then `ts_sm` is a row vector containing the sum of each column of `ts.Data`.

When `ts.Data` is a N-dimensional array, `sum` always operates along the first nonsingleton dimension of `ts.Data`.

## Examples

Calculate the sum of each data column for a `timeseries` object:

```
% Load a 24-by-3 data array:
```

```
load count.dat
```

```
% Create a timeseries object with 24 time values:
```

```
count_ts = timeseries(count,1:24,'Name','CountPerSecond');
```

```
% Calculate the sum of each data column for this timeseries object:
```

```
sum(count_ts)
```

```
MATLAB returns:
```

```
768 1117 1574
```

## Algorithms

MATLAB determines weighting by:

- 1 Attaching a weighting to each time value, depending on its order, as follows:
  - First time point — The duration of the first time interval ( $t(2) - t(1)$ ).
  - Time point that is neither the first nor last time point — The duration between the midpoint of the previous time interval to the midpoint of the subsequent time interval ( $(t(k + 1) - t(k))/2 + (t(k) - t(k - 1))/2$ ).
  - Last time point — The duration of the last time interval ( $(t(\text{end}) - t(\text{end} - 1))$ ).
- 2 Normalizing the weighting for each time by dividing each weighting by the mean of all weightings.

---

**Note** If the `timeseries` object is uniformly sampled, then the normalized weighting for each time is 1.0. Therefore, time weighting has no effect.

---

- 3 Multiplying the data for each time by its normalized weighting.

## See Also

`iqr` | `max` | `mean` | `median` | `min` | `std` | `timeseries` | `var`

---

<b>Purpose</b>	Variance of timeseries data
<b>Syntax</b>	<pre>ts_var = var(ts) ts_var = var(ts,Name,Value)</pre>
<b>Description</b>	<p><code>ts_var = var(ts)</code> returns the variance of <code>ts.data</code>.</p> <p><code>ts_var = var(ts,Name,Value)</code> uses additional options specified by one or more <code>Name,Value</code> pair arguments.</p>
<b>Input Arguments</b>	<p><b>ts</b></p> <p>The timeseries object for which you want the variance of the data.</p> <p><b>Name-Value Pair Arguments</b></p> <p>Specify optional comma-separated pairs of <code>Name,Value</code> arguments. <code>Name</code> is the argument name and <code>Value</code> is the corresponding value. <code>Name</code> must appear inside single quotes ( ' '). You can specify several name and value pair arguments in any order as <code>Name1,Value1,...,NameN,ValueN</code>.</p> <p><b>'MissingData'</b></p> <p>A string specifying one of two possible values, <code>remove</code> or <code>interpolate</code>, indicating how to treat missing data during the calculation.</p> <p><b>Default:</b> <code>remove</code></p> <p><b>'Quality'</b></p> <p>A vector of integers, indicating which quality codes represent missing samples (for vector data) or missing observations (for data arrays with two or more dimensions).</p> <p><b>'Weighting'</b></p>

# timeseries.var

---

A string specifying one of two possible values, `none` or `time`.  
When you specify `time`, larger time values correspond to larger weights.

## Output Arguments

### `ts_var`

The variance of `ts.data`, as follows:

- When `ts.Data` is a vector, then `ts_var` is the variance of `ts.Data` values.
- When `ts.Data` is a matrix, and `IsTimeFirst` is `true`, and the first dimension of `ts` is aligned with time, then `ts_var` is a row vector containing the variance of each column of `ts.Data`.

When `ts.Data` is an N-dimensional array, `var` always operates along the first nonsingleton dimension of `ts.Data`.

## Examples

The following example calculates the variance values of a multivariate `timeseries` object. MATLAB calculates the variance independently for each data column in the `timeseries` object.

Load a 24-by-3 data array. Then create a `timeseries` object with 24 time values.

```
load count.dat
count_ts = timeseries(count,[1:24], 'Name', 'CountPerSecond');
```

Calculate the variance of each data column.

```
var(count_ts)
```

MATLAB returns:

```
1.0e+03 *
 0.6437 1.7144 4.6278
```

## Algorithms

MATLAB determines weighting by:

- 1 Attaching a weighting to each time value, depending on its order, as follows:
  - First time point — The duration of the first time interval ( $t(2) - t(1)$ ).
  - Time point that is neither the first nor last time point — The duration between the midpoint of the previous time interval to the midpoint of the subsequent time interval ( $(t(k + 1) - t(k))/2 + (t(k) - t(k - 1))/2$ ).
  - Last time point — The duration of the last time interval ( $(t(\text{end}) - t(\text{end} - 1))$ ).
- 2 Normalizing the weighting for each time by dividing each weighting by the mean of all weightings.

---

**Note** If the `timeseries` object is uniformly sampled, then the normalized weighting for each time is 1.0. Therefore, time weighting has no effect.

---

- 3 Multiplying the data for each time by its normalized weighting.

## See Also

`iqr` | `max` | `mean` | `median` | `min` | `std` | `timeseries` | `sum`

# triangulation

---

**Purpose** Triangulation in 2-D or 3-D

**Description** Use `triangulation` to create an in-memory representation of any 2-D or 3-D triangulation data that is in matrix format, such as the matrix output from the `delaunay` function or other software tools. When your data is represented using `triangulation`, you can perform topological and geometric queries, which you can use to develop geometric algorithms. For example, you can find the triangles or tetrahedra attached to a vertex, those that share an edge, their circumcenters, and other features.

**Construction** `TR = triangulation(T,P)` creates a 2-D or 3-D triangulation representation using the triangulation connectivity list, `T`, and the points in matrix `P`.

`TR = triangulation(T,x,y)` creates a 2-D triangulation representation with the point coordinates specified as column vectors, `x` and `y`.

`TR = triangulation(T,x,y,z)` creates a 3-D triangulation representation with the point coordinates specified as column vectors, `x`, `y`, and `z`.

## Input Arguments

**T**

Triangulation connectivity list, specified as an  $m$ -by- $n$  matrix, where  $m$  is the number of triangles or tetrahedra, and  $n$  is the number of vertices per triangle or tetrahedron. Each element in `T` is a “Vertex ID” on page 1-5784. Each row of `T` contains the vertex IDs that define a triangle or tetrahedron.

**P**

Points, specified as a matrix whose columns are the `x`, `y`, (and possibly `z`) coordinates of the triangulation points. The row numbers of `P` are the vertex IDs in the triangulation.

**x**



*x*-coordinates vector, specified as a column vector containing the *x*-coordinates of the triangulation points.

## **y**

*y*-coordinates vector, specified as a column vector containing the *y*-coordinates of the triangulation points.

## **z**

*z*-coordinates vector, specified as a column vector containing the *z*-coordinates of the triangulation points.

## **Properties**

### **Points**

Points in the triangulation, represented as a matrix containing the following information:

- Each row in `TR.Points` contains the coordinates of a vertex.
- Each row number of `TR.Points` is a vertex ID.

### **ConnectivityList**

Triangulation connectivity list, represented as a matrix. This matrix contains the following information:

- Each element in `TR.ConnectivityList` is a vertex ID.
- Each row represents a triangle or tetrahedron in the triangulation.
- Each row number of `TR.ConnectivityList` is a “Triangle or Tetrahedron ID” on page 1-5784.

## **Methods**

<code>barycentricToCartesian</code>	Converts point coordinates from barycentric to Cartesian
<code>cartesianToBarycentric</code>	Converts point coordinates from Cartesian to barycentric

# triangulation

---

circumcenter	Circumcenter of triangle or tetrahedron
edgeAttachments	Triangles or tetrahedra attached to specified edge
edges	Triangulation edges
faceNormal	Triangulation face normal
featureEdges	Triangulation sharp edges
freeBoundary	Triangulation facets referenced by only one triangle or tetrahedron
incenter	Incenter of triangle or tetrahedron
isConnected	Test if two vertices are connected by edge
neighbors	Neighbors to specified triangle or tetrahedron
size	Size of triangulation connectivity list
vertexAttachments	Triangles or tetrahedra attached to specified vertex
vertexNormal	Triangulation vertex normal

## Definitions

### Vertex ID

A row number of the matrix, `TR.Points`. Use this ID to refer a specific vertex in the triangulation.

### Triangle or Tetrahedron ID

A row number of the matrix, `TR.ConnectivityList`. Use this ID to refer a specific triangle or tetrahedron.

## Copy Semantics

Value. To learn how value classes affect copy operations, see Copying Objects in the MATLAB documentation.

## Examples

### 2-D Triangulation

Define the points in the triangulation.

```
P = [2.5 8.0
 6.5 8.0
 2.5 5.0
 6.5 5.0
 1.0 6.5
 8.0 6.5];
```

Define the triangles. This is the triangulation connectivity list.

```
T = [5 3 1;
 3 2 1;
 3 4 2;
 4 6 2];
```

Create the triangulation representation.

```
TR = triangulation(T,P)
```

```
TR =
```

```
triangulation with properties:
```

```
 Points: [6x2 double]
ConnectivityList: [4x3 double]
```

Examine the coordinates of the vertices of the first triangle.

```
TR.Points(TR.ConnectivityList(1,:),:)
```

```
ans =
```

```
 1.0000 6.5000
```

# triangulation

---

2.5000	5.0000
2.5000	8.0000

**See Also** [delaunayTriangulation](#)

<b>Purpose</b>	Converts point coordinates from barycentric to Cartesian
<b>Syntax</b>	<code>PC = barycentricToCartesian(TR,ti,B)</code>
<b>Description</b>	<code>PC = barycentricToCartesian(TR,ti,B)</code> returns the Cartesian coordinates of the points in <code>B</code> . Each row, <code>B(j,:)</code> , contains the barycentric coordinates of a point with respect to the triangle or tetrahedron, <code>ti(j)</code> . The point, <code>PC(j,:)</code> , is the <code>j</code> th point represented in Cartesian coordinates.
<b>Input Arguments</b>	<b>TR</b> Triangulation representation, see <code>triangulation</code> or <code>delaunayTriangulation</code> . <b>ti</b> Triangle or tetrahedron IDs, specified as a column vector. <b>B</b> Barycentric coordinates, specified as a matrix. Each row, <code>B(j,:)</code> , contains the barycentric coordinates of a point with respect to the triangle or tetrahedron, <code>ti(j)</code> .
<b>Output Arguments</b>	<b>PC</b> Cartesian coordinates, returned as a matrix. The point, <code>PC(j,:)</code> , is the <code>j</code> th point represented in Cartesian coordinates.
<b>Definitions</b>	<b>Triangle or Tetrahedron ID</b> A row number of the matrix, <code>TR.ConnectivityList</code> . Use this ID to refer a specific triangle or tetrahedron.
<b>Examples</b>	<b>Barycentric Coordinates Converted to Cartesian Coordinates</b> Create a triangulation from a set of points, <code>P</code> , and triangulation connectivity list, <code>T</code> .

# triangulation.barycentricToCartesian

---

```
P = [2.5 8.0
 6.5 8.0
 2.5 5.0
 6.5 5.0
 1.0 6.5
 8.0 6.5];
```

```
T = [5 3 1;
 3 2 1;
 3 4 2;
 4 6 2];
```

```
TR = triangulation(T,P);
```

Specify the first triangle.

```
ti = 1;
```

Specify the barycentric coordinates of the second point in the triangle.

```
B = [0 1 0];
```

Convert the point to Cartesian coordinates.

```
PC = barycentricToCartesian(TR,ti,B)
```

```
PC =
```

```
2.5000 5.0000
```

## Mapped Incenters of Deformed Triangulation

Create a Delaunay triangulation from a set of points.

```
x = [0 4 8 12 0 4 8 12]';
```

```
y = [0 0 0 0 8 8 8 8]';
DT = delaunayTriangulation(x,y);
```

Calculate the Cartesian coordinates of the incenters.

```
cc = incenter(DT);
```

Plot the original triangulation and reference points.

```
figure
subplot(1,2,1);
triplot(DT);
hold on;
plot(cc(:,1),cc(:,2), '*r');
hold off;
axis equal;
```

# triangulation.barycentricToCartesian

---

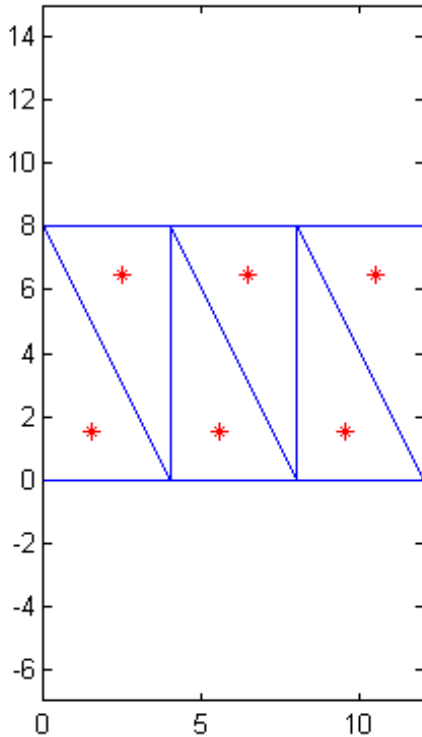

Create a new triangulation which is a deformed version of DT .

```
ti = DT.ConnectivityList;
y = [0 0 0 0 16 16 16 16]';
TR = triangulation(ti,x,y);
```

Compute the barycentric coordinates for the incenters of DT, and use them to compute the Cartesian coordinates of the analogous points in TR.

```
b = cartesianToBarycentric(DT,[1:length(ti)]',cc);
```



```
xc = barycentricToCartesian(TR,[1:length(ti)]',b);
```

Plot the deformed triangulation and mapped locations of the reference points.

```
subplot(1,2,2);
triplot(TR);
hold on;
plot(xc(:,1),xc(:,2),'*r');
hold off;
axis equal;
```

# triangulation.barycentricToCartesian

---

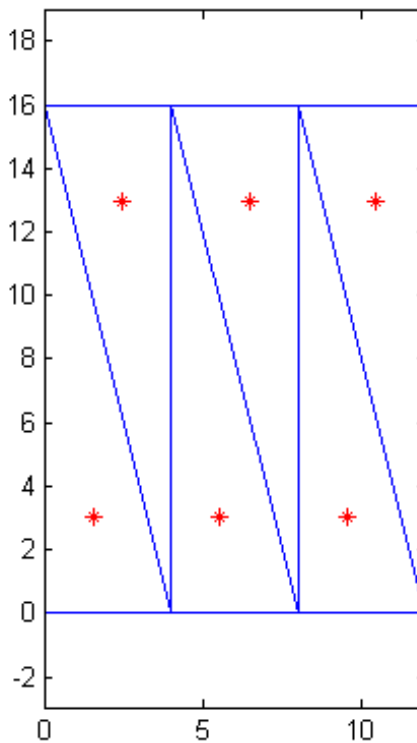
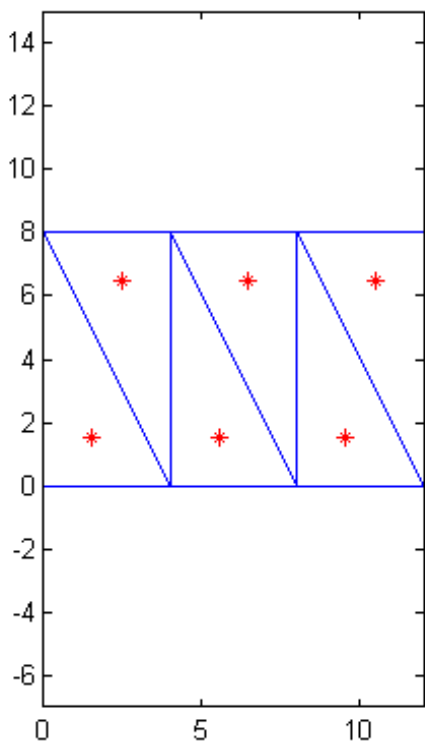

**See Also**

`cartesianToBarycentric` | `delaunayTriangulation`

<b>Purpose</b>	Converts point coordinates from Cartesian to barycentric
<b>Syntax</b>	<code>B = cartesianToBarycentric(TR,ti,PC)</code>
<b>Description</b>	<code>B = cartesianToBarycentric(TR,ti,PC)</code> returns the barycentric coordinates of the points in <code>PC</code> . Each row, <code>PC(j,:)</code> , contains the Cartesian coordinates of a point you want to convert. <code>B(j,:)</code> are the barycentric coordinates of the point, <code>PC(j,:)</code> , with respect to triangle or tetrahedron, <code>ti(j)</code> .
<b>Input Arguments</b>	<b>TR</b> Triangulation representation, see <code>triangulation</code> or <code>delaunayTriangulation</code> . <b>ti</b> Triangle or tetrahedron IDs, specified as a column vector. <b>PC</b> Cartesian coordinates, specified as a matrix. Each row, <code>PC(j,:)</code> , contains the Cartesian coordinates of a point with respect to triangle or tetrahedron, <code>ti(j)</code> .
<b>Output Arguments</b>	<b>B</b> Barycentric coordinates, returned as a matrix. <code>B(j,:)</code> are the barycentric coordinates of <code>PC(j,:)</code> with respect to <code>ti(j)</code> .
<b>Definitions</b>	<b>Triangle or Tetrahedron ID</b> A row number of the matrix, <code>TR.ConnectivityList</code> . Use this ID to refer a specific triangle or tetrahedron.
<b>Examples</b>	<b>Cartesian Coordinates Coverted to Barycentric Coordinates</b> Create a triangulation from a set of points, <code>P</code> , and triangulation connectivity list, <code>T</code> .

# triangulation.cartesianToBarycentric

---

```
P = [2.5 8.0
 6.5 8.0
 2.5 5.0
 6.5 5.0
 1.0 6.5
 8.0 6.5];
```

```
T = [5 3 1;
 3 2 1;
 3 4 2;
 4 6 2];
```

```
TR = triangulation(T,P);
```

Specify the first triangle.

```
ti = 1;
```

Get the coordinates of the third vertex in the first triangle.

```
PC = TR.Points(TR.ConnectivityList(1,3),:)
```

```
PC =
```

```
2.5000 8.0000
```

Convert the point to barycentric coordinates.

```
B = cartesianToBarycentric(TR,ti,PC)
```

```
B =
```

```
0 0 1
```

## Mapped Incenters of Deformed Triangulation

Create a Delaunay triangulation from a set of points.

```
x = [0 4 8 12 0 4 8 12]';
y = [0 0 0 0 8 8 8 8]';
DT = delaunayTriangulation(x,y);
```

Calculate the Cartesian coordinates of the incenters.

```
cc = incenter(DT);
```

Plot the original triangulation and reference points.

```
figure
subplot(1,2,1);
triplot(DT);
hold on;
plot(cc(:,1),cc(:,2),'*r');
hold off;
axis equal;
```

# triangulation.cartesianToBarycentric

---

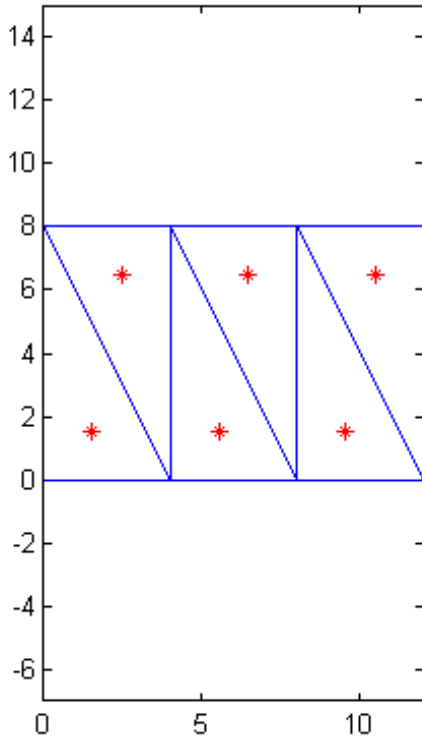

Create a new triangulation which is a deformed version of DT .

```
ti = DT.ConnectivityList;
y = [0 0 0 0 16 16 16 16]';
TR = triangulation(ti,x,y);
```

Compute the barycentric coordinates for the incenters of DT, and use them to compute the Cartesian coordinates of the analogous points in TR.

```
b = cartesianToBarycentric(DT,[1:length(ti)]',cc);
```

```
xc = barycentricToCartesian(TR,[1:length(ti)]',b);
```

Plot the deformed triangulation and mapped locations of the reference points.

```
subplot(1,2,2);
triplot(TR);
hold on;
plot(xc(:,1),xc(:,2),'*r');
hold off;
axis equal;
```

# triangulation.cartesianToBarycentric

---

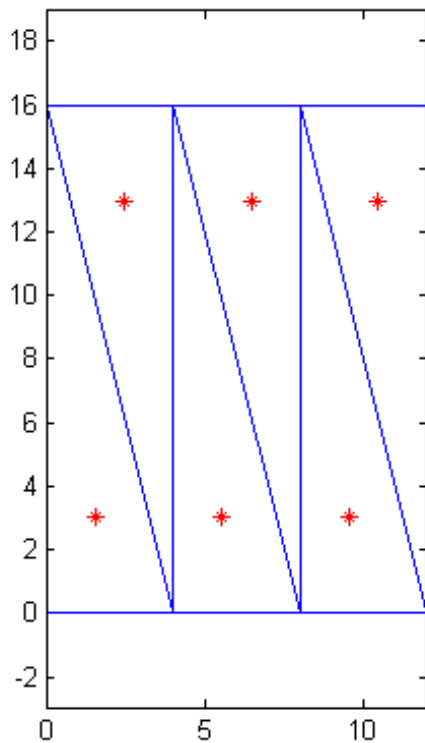
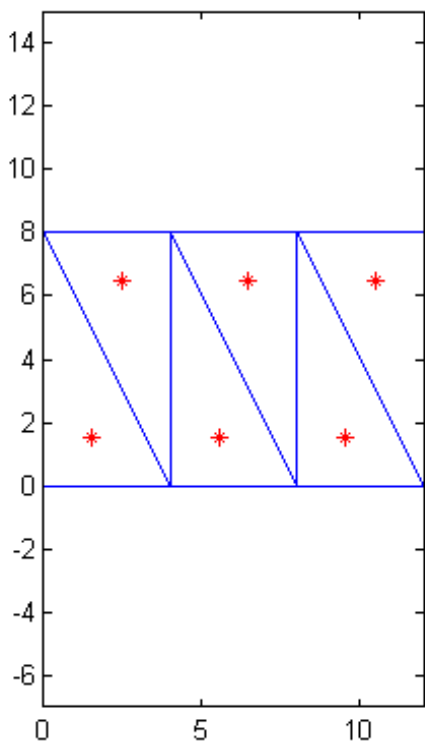

**See Also**

[barycentricToCartesian](#) | [delaunayTriangulation](#)



**Purpose** Circumcenter of triangle or tetrahedron

**Syntax**

```
CC = circumcenter(TR,ti)
[CC,r] = circumcenter(TR,ti)
CC = circumcenter(TR)
[CC,r] = circumcenter(TR)
```

**Description**

`CC = circumcenter(TR,ti)` returns the coordinates of the circumcenter of each triangle or tetrahedron specified in `ti`.

`[CC,r] = circumcenter(TR,ti)` also returns the corresponding radii of the circumscribed circles or spheres.

`CC = circumcenter(TR)` returns the circumcenters of all triangles or tetrahedra in the triangulation.

`[CC,r] = circumcenter(TR)` also returns the corresponding radii of the circumscribed circles or spheres for the entire triangulation.

**Input Arguments**

**TR**

Triangulation representation, see `triangulation` or `delaunayTriangulation`.

**ti**

Triangle or tetrahedron IDs, specified as a column vector.

**Output Arguments**

**CC**

Circumcenters, returned as a matrix. Each row, `CC(j,:)`, contains the coordinates of the circumcenter of `ti(j)`.

**r**

Radii of the circumscribed circles or spheres, returned as a vector. The radius at `r(j)` corresponds to the circle or sphere circumscribing `ti(j)`.

# triangulation.circumcenter

---

## Definitions

### Triangle or Tetrahedron ID

A row number of the matrix, `TR.ConnectivityList`. Use this ID to refer a specific triangle or tetrahedron.

## Examples

### Circumcenters in 2-D Triangulation

Load 2-D triangulation data and create a triangulation representation.

```
load trimesh2d
TR = triangulation(tri,x,y);
```

Compute the circumcenters.

```
CC = circumcenter(TR);
triplot(TR)
axis([-50 350 -50 350]);
axis equal;
hold on;
plot(CC(:,1),CC(:,2),'*r');
hold off;
```

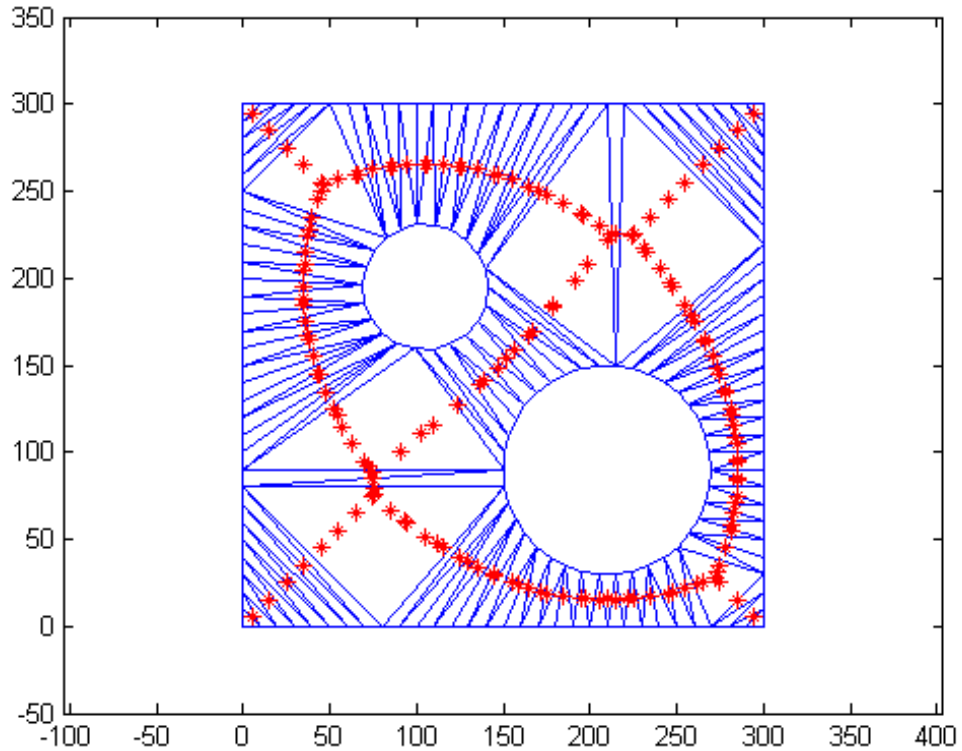

The circumcenters represent points on the medial axis of the polygon.

## **Circumcenters in 3-D Delaunay Triangulation**

Create the Delaunay triangulation using a random set of points, P.

```
P = gallery('uniformdata',10,3,0);
DT = delaunayTriangulation(P);
```

Calculate the circumcenters of the first five tetrahedra in DT.

# triangulation.circumcenter

---

```
CC = circumcenter(DT,[1:5]')
```

```
CC =
```

```
 0.9626 0.3892 0.0928
 6.3458 0.2377 3.1814
 0.4820 0.9064 0.5176
 -1.2993 1.8384 -1.2185
 -0.1595 1.0852 -0.2536
```

**See Also**      [incenter](#) | [delaunayTriangulation](#)

**Purpose**

Triangles or tetrahedra attached to specified edge

**Syntax**

```
ti = edgeAttachments(TR,vstart,vend)
ti = edgeAttachments(TR,E)
```

**Description**

`ti = edgeAttachments(TR,vstart,vend)` returns the triangles or tetrahedra attached to the specified edges. To specify the edges, use the vectors, `vstart` and `vend`. These vectors contain the “Vertex ID” on page 1-5804 at the start and end of each edge.

`ti = edgeAttachments(TR,E)` specifies the starting and ending vertices of each edge in a 2-column matrix, `E`.

**Input Arguments****TR**

Triangulation representation, see `triangulation` or `delaunayTriangulation`.

**vstart**

IDs of starting vertices, specified as a column vector of vertex IDs. Each ID refers to a vertex at the start of an edge.

**vend**

IDs of ending vertices, specified as a column vector of vertex IDs. Each ID refers to a vertex at the end of an edge.

**E**

IDs of the edge vertices, specified as a 2-column matrix of vertex IDs. Each row of `E` corresponds to an edge and contains two IDs:

- $E(j,1)$  is the ID of the vertex at the start of an edge.
- $E(j,2)$  is the ID of the vertex at end of the edge.

**Output Arguments****ti**

IDs of the triangles or tetrahedra attached to the edges, returned as an  $m$ -by-1 cell array. Each cell in `ti` contains the IDs of the

# triangulation.edgeAttachments

---

attached triangles or tetrahedra. The attachments to the edge located between the vertices, `vstart(j)` and `vend(j)`, or `E(j, :)`, are returned in `ti{j}`. The attachments are returned in a cell array because the number of triangles or tetrahedra associated with each edge can vary.

## Definitions

### Vertex ID

A row number of the matrix, `TR.Points`. Use this ID to refer a specific vertex in the triangulation.

### Triangle or Tetrahedron ID

A row number of the matrix, `TR.ConnectivityList`. Use this ID to refer a specific triangle or tetrahedron.

## Examples

### Edge Attachments in 3-D Triangulation

Load 2-D triangulation data and create a triangulation representation.

```
load tetmesh
TR = triangulation(tet,X);
```

Define the starting and ending vertices of the edges.

```
vstart = [15; 21];
vend = [936; 716];
```

Find the edge attachments.

```
ti = edgeAttachments(TR,vstart,vend);
```

Examine the attachments to the first edge.

```
ti{1}
```

```
ans =
```

```
 927 2060 3438 3423 2583 4690
```

## Edge Attachments in 2-D Delaunay Triangulation

Create a Delaunay triangulation.

```
x = [0 1 1 0 0.5]';
y = [0 0 1 1 0.5]';
DT = delaunayTriangulation(x,y);
```

Find the triangles attached to edge (1,5).

```
ti = edgeAttachments(DT,1,5);
ti{:}
```

```
ans =
```

```
 4 1
```

## See Also

[edges](#) | [vertexAttachments](#) | [delaunayTriangulation](#)

# triangulation.edges

---

<b>Purpose</b>	Triangulation edges
<b>Syntax</b>	<code>E = edges(TR)</code>
<b>Description</b>	<code>E = edges(TR)</code> returns the triangulation edges as a matrix of vertex IDs. The vertices referenced in <code>E</code> indicate the beginning and end of each edge.
<b>Input Arguments</b>	<b>TR</b> Triangulation representation, see <code>triangulation</code> or <code>delaunayTriangulation</code> .
<b>Output Arguments</b>	<b>E</b> Edge vertex IDs, returned as a 2-column matrix. Each row of <code>E</code> corresponds to an edge and contains two IDs: <ul style="list-style-type: none"><li>• <code>E(j,1)</code> is the ID of the vertex at the start of the edge.</li><li>• <code>E(j,2)</code> is the ID of the vertex at end of the edge.</li></ul>
<b>Definitions</b>	<b>Vertex ID</b> A row number of the matrix, <code>TR.Points</code> . Use this ID to refer a specific vertex in the triangulation.
<b>Examples</b>	<b>Edges in a 2-D Triangulation</b> Load 2-D triangulation data and create a triangulation representation. <pre>load trimesh2d TR = triangulation(tri,x,y);</pre> Find the edges in the triangulation. <pre>E = edges(TR);</pre> List the first five edges.



```
E(1:5,:)
```

```
ans =
```

```
 1 2
 1 118
 1 119
 1 120
 2 3
```

## Edges in a 2-D Delaunay Triangulation

Create 2-D Delaunay triangulation from a set of 10 random points.

```
X = gallery('uniformdata',[10, 2],0);
DT = delaunayTriangulation(X);
```

Find the edges in the triangulation.

```
E = edges(DT)
```

```
E =
```

```
 1 3
 1 4
 1 5
 1 6
 1 9
 2 4
 2 5
 2 6
 2 7
 2 8
 2 10
 3 4
 3 7
 3 10
 4 6
 4 10
```

# triangulation.edges

---

```
5 6
5 8
5 9
6 9
7 8
7 10
```

## See Also

[edgeAttachments](#) | [delaunayTriangulation](#)

<b>Purpose</b>	Triangulation face normal
<b>Syntax</b>	<pre>FN = faceNormal(TR,ti) FN = faceNormal(TR)</pre>
<b>Description</b>	<p>FN = faceNormal(TR,ti) returns the unit normal vector to each triangle specified by ti. The faceNormal function supports only 2-D triangulations.</p> <p>FN = faceNormal(TR) returns the unit normal vectors to all triangles.</p>
<b>Input Arguments</b>	<p><b>TR</b></p> <p>Triangulation representation, see triangulation or delaunayTriangulation.</p> <p><b>ti</b></p> <p>Triangle IDs, specified as a column vector.</p>
<b>Output Arguments</b>	<p><b>FN</b></p> <p>Face normals, returned as a matrix. Each row, FN(j,:), is the unit normal vector to triangle ti(j).</p> <p>If you do not specify ti, then faceNormal returns the unit normal information for the entire triangulation. In this case, the normal associated with TR.ConnectivityList(j,:) is FN(j,:).</p>
<b>Definitions</b>	<p><b>Triangle ID</b></p> <p>A row number of the matrix, TR.ConnectivityList. You use this ID to refer a specific triangle.</p>
<b>Examples</b>	<p><b>Plot Unit Normals to Facets on a Spherical Surface</b></p> <p>Create a set of random points on a spherical surface.</p> <pre>theta = gallery('uniformdata',[100,1],0)*2*pi; phi = gallery('uniformdata',[100,1],1)*pi;</pre>

# triangulation.faceNormal

---

```
x = cos(theta).*sin(phi);
y = sin(theta).*sin(phi);
z = cos(phi);
```

Triangulate the points with delaunayTriangulation.

```
DT = delaunayTriangulation(x,y,z);
```

Find the free boundary facets and use them to create a triangulation representation for plotting.

```
[T,Xb] = freeBoundary(DT);
TR = triangulation(T,Xb);
```

Plot the triangulation.

```
figure
trisurf(T,Xb(:,1),Xb(:,2),Xb(:,3), ...
 'FaceColor', 'cyan', 'faceAlpha', 0.8);
axis equal;
hold on;

% Calculate the incenters and face normals.
P = incenter(TR);
fn = faceNormal(TR);

% Display the normal vectors on the surface.
quiver3(P(:,1),P(:,2),P(:,3), ...
 fn(:,1),fn(:,2),fn(:,3),0.5, 'color','r');
hold off;
```

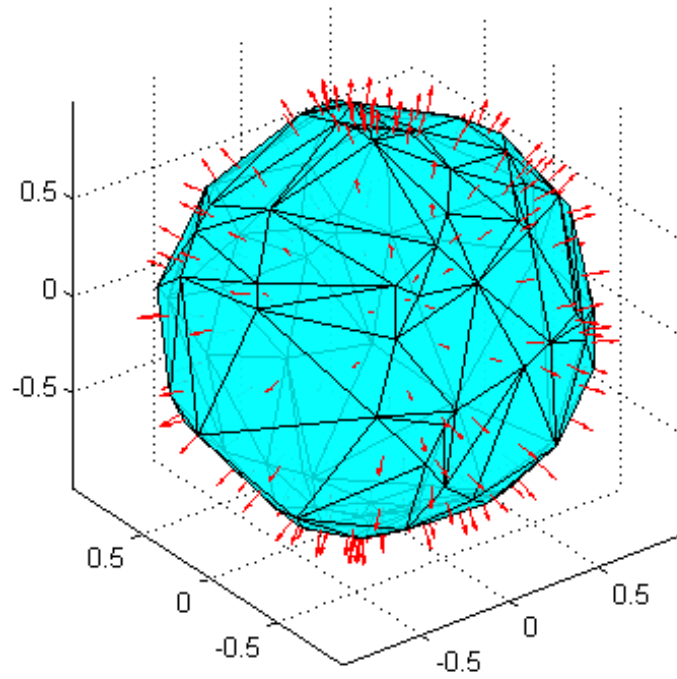

## See Also

[freeBoundary](#) | [delaunayTriangulation](#)

# triangulation.featureEdges

---

<b>Purpose</b>	Triangulation sharp edges
<b>Syntax</b>	<code>FE = featureEdges(TR,filterangle)</code>
<b>Description</b>	<p><code>FE = featureEdges(TR,filterangle)</code> returns the feature edges in a 2-D triangulation.</p> <p>Use this method to extract the sharp edges in the surface mesh for display purposes. A feature edge is an edge that has any of the following attributes:</p> <ul style="list-style-type: none"><li>• The edge is shared by only one triangle.</li><li>• The edge is shared by more than two triangles.</li><li>• The edge is shared by a pair of triangles with angular deviation greater than the <code>filterangle</code>.</li></ul>
<b>Input Arguments</b>	<p><b>TR</b></p> <p>Triangulation representation, see <code>triangulation</code> or <code>delaunayTriangulation</code>.</p> <p><b>filterangle</b></p> <p>Filter angle, specified as a scalar value in the range <math>[0,\pi]</math>. <code>featureEdges</code> returns adjacent triangles that have a dihedral angle that deviates from <math>\pi</math> by an angle greater than <code>filterangle</code>.</p>
<b>Output Arguments</b>	<p><b>FE</b></p> <p>Feature edge vertex IDs, returned as a two-column matrix. Each row of <code>FE</code> corresponds to a feature edge and contains two IDs:</p> <ul style="list-style-type: none"><li>• <code>FE(j,1)</code> is the ID of the vertex at the start of the edge.</li><li>• <code>FE(j,2)</code> is the ID of the vertex at end of the edge.</li></ul>

## Definitions

### Vertex ID

A row number of the matrix, `TR.Points`. Use this ID to refer a specific vertex in the triangulation.

## Examples

### Feature Edges Shown on a Surface

Use `featureEdges` to find the feature edges of a surface and display them on a plot.

Create a surface triangulation.

```
x = [0 0 0 0 0 3 3 3 3 3 3 6 6 6 6 6 9 9 9 9 9 9]';
y = [0 2 4 6 8 0 1 3 5 7 8 0 2 4 6 8 0 1 3 5 7 8]';
DT = delaunayTriangulation(x,y);
T = DT(:,:);
```

Elevate the 2-D mesh to create a surface.

```
z = [0 0 0 0 0 2 2 2 2 2 2 0 0 0 0 0 0 0 0 0 0 0]';
subplot(1,2,1);
trisurf(T,x,y,z,'FaceColor','cyan');
axis equal;
```

# triangulation.featureEdges

---

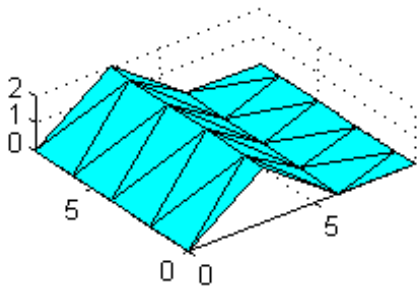

Compute the feature edges using a filter angle of  $\pi/6$ .

```
TR = triangulation(T,x,y,z);
fe = featureEdges(TR,pi/6)';
subplot(1,2,2);
trisurf(TR,'FaceColor','cyan','EdgeColor',...
'none','FaceAlpha',0.8);
axis equal;
```

```
% Add the feature edges to the plot.
```



```
hold on;
plot3(x(fe), y(fe), z(fe), 'k', 'LineWidth',1.5);
hold off;
```

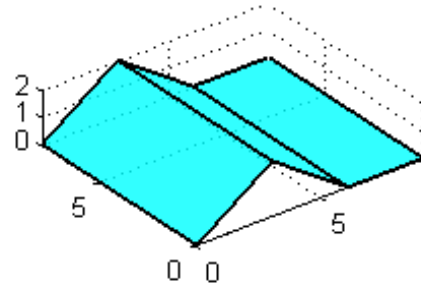
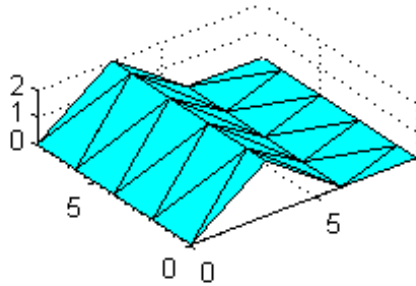

**See Also** [edges](#) | [delaunayTriangulation](#)

# triangulation.freeBoundary

---

**Purpose** Triangulation facets referenced by only one triangle or tetrahedron

**Syntax** `FBtri = freeBoundary(TR)`  
`[FBtri,FBpoints] = freeBoundary(TR)`

**Description** `FBtri = freeBoundary(TR)` returns the free boundary facets of `TR.ConnectivityList`. A facet in `TR` is on the free boundary if it is referenced by only one triangle or tetrahedron.

`[FBtri,FBpoints] = freeBoundary(TR)` also returns a matrix containing the vertices of the free boundary facets.

## Input Arguments

**TR**  
Triangulation representation, see `triangulation` or `delaunayTriangulation`.

## Output Arguments

**FBtri**  
Triangulation connectivity list, returned as a matrix that contains the following information:

- Each row in `FBtri` represents a facet on the free boundary.
- Each element is a “Vertex ID” on page 1-5817.

The vertex IDs in `FBtri` reference a specific matrix, depending on the syntax you choose:

- If you call `freeBoundary` with one output argument, then the elements of `FBtri` are row numbers of `TR.Points`.
- If you call `freeBoundary` with two output arguments, then the elements of `FBtri` are row numbers of `FBpoints`.

**FBpoints**

Free boundary points, returned as a matrix containing the coordinates of the vertices of the free boundary facets. Each row of `FBpoints` contains coordinates of a vertex.

## Definitions

### Vertex ID

A row number of the matrix, `TR.Points` or `FBpoints`. Use this ID to refer a specific vertex in the triangulation.

## Examples

### Surface of 3-D Triangulation

Use `freeBoundary` to extract the facets of a 3-D triangulation that cover the surface of an object.

Load a 3-D triangulation.

```
load tetmesh;
TR = triangulation(tet,X);
```

Compute the boundary triangulation.

```
[FBtri,FBpoints] = freeBoundary(TR);
```

Plot the boundary triangulation.

```
trisurf(FBtri,FBpoints(:,1),FBpoints(:,2),FBpoints(:,3), ...
 'FaceColor','cyan','FaceAlpha', 0.8);
```

# triangulation.freeBoundary

---

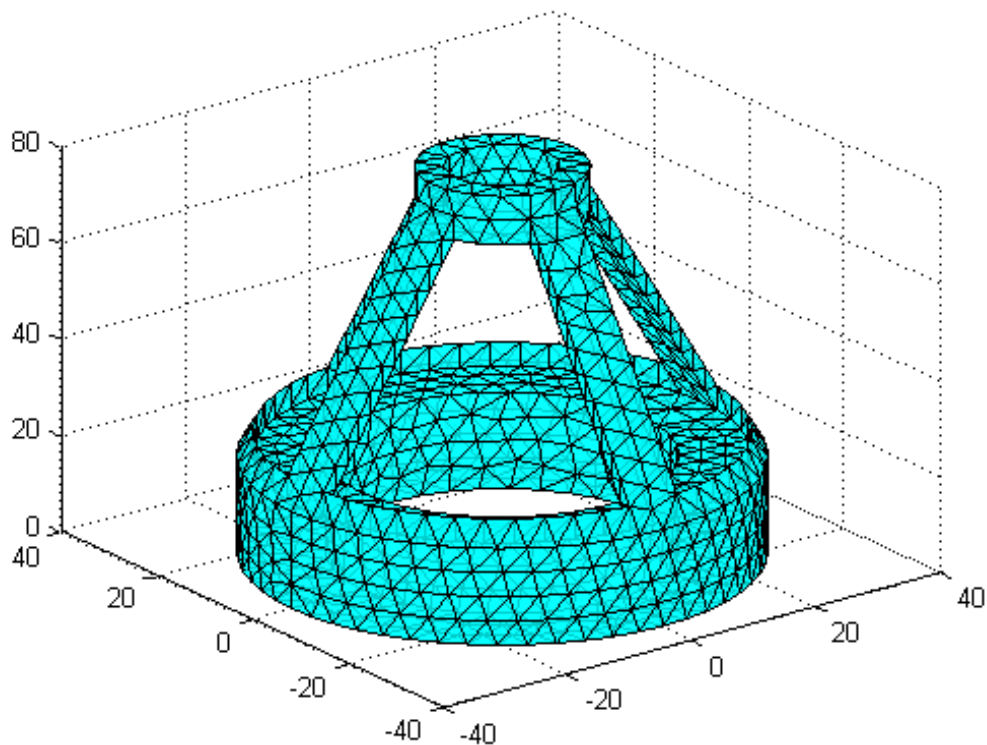

## Free Boundary of 2-D Delaunay Triangulation

Use `freeBoundary` when you want to highlight the outer edges of a 2-D Delaunay triangulation.

Create a triangulation from a random set of points.

```
x = gallery('uniformdata',[20,1],0);
y = gallery('uniformdata',[20,1],1);
DT = delaunayTriangulation(x,y);
```

Find the free boundary edges.

```
fe = freeBoundary(DT)';
```

Plot the mesh and highlight the free boundary edges in red.

```
triplot(DT);
hold on;
plot(x(fe),y(fe),'-r','LineWidth',2) ;
hold off;
```

# triangulation.freeBoundary

---

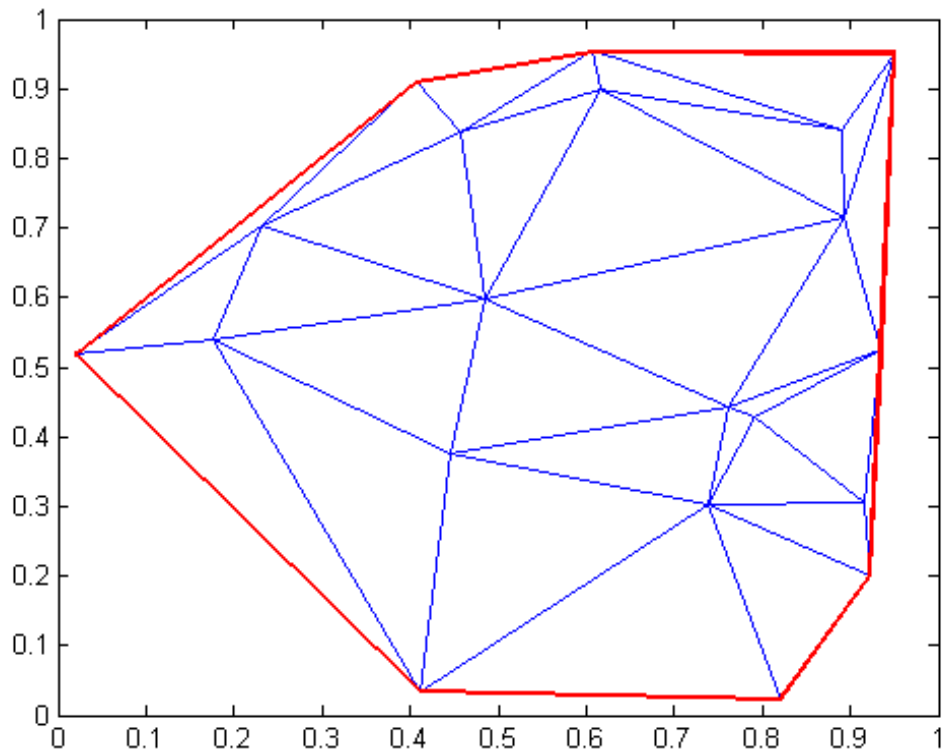

## See Also

[featureEdges](#) | [faceNormal](#) | [delaunayTriangulation](#)

<b>Purpose</b>	Incenter of triangle or tetrahedron
<b>Syntax</b>	<code>IC = incenter(TR,ti)</code> <code>[IC,r] = incenter(TR,ti)</code>
<b>Description</b>	<code>IC = incenter(TR,ti)</code> returns the coordinates of the incenter of each triangle or tetrahedron specified by <code>ti</code> . <code>[IC,r] = incenter(TR,ti)</code> also returns the radii of the inscribed circles or spheres.
<b>Input Arguments</b>	<b>TR</b> Triangulation representation, see <code>triangulation</code> or <code>delaunayTriangulation</code> . <b>ti</b> Triangle or tetrahedron IDs, specified as a column vector.
<b>Output Arguments</b>	<b>IC</b> Incenters, returned as a matrix. Each row of <code>IC</code> contains the coordinates of an incenter. For example, <code>IC(j,:)</code> is the incenter of <code>ti(j)</code> . <b>r</b> Radii of the inscribed circles or spheres, returned as a vector. <code>r(j)</code> is the radius of the inscribed circle or sphere whose center is <code>IC(j,:)</code> .
<b>Definitions</b>	<b>Triangle or Tetrahedron ID</b> A row number of the matrix, <code>TR.ConnectivityList</code> . Use this ID to refer a specific triangle or tetrahedron.
<b>Examples</b>	<b>Find Incenters in 3-D Triangulation</b> Load a 3-D triangulation.

# triangulation.incenter

---

```
load tetmesh
```

Calculate the incenters of the first five tetrahedra.

```
TR = triangulation(tet,X);
IC = incenter(TR,[1:5]')
```

```
IC =
```

```
-6.1083 -31.0234 8.1439
-2.1439 -31.0283 5.8742
-1.9555 -31.9463 7.4112
-4.3019 -30.8460 10.5169
-3.1596 -29.3642 6.1851
```

## Find Incenters in 2-D Delaunay Triangulation

Create the Delaunay triangulation.

```
x = [0 1 1 0 0.5]';
y = [0 0 1 1 0.5]';
DT = delaunayTriangulation(x,y);
```

Calculate incenters of the triangles

```
IC = incenter(DT)
```

```
IC =
```

```
0.2071 0.5000
0.5000 0.7929
0.7929 0.5000
0.5000 0.2071
```



Plot the triangles and incenters.

```
triplot(DT);
axis equal;
axis([-0.2 1.2 -0.2 1.2]);
hold on;
plot(IC(:,1),IC(:,2),'*r');
hold off;
```

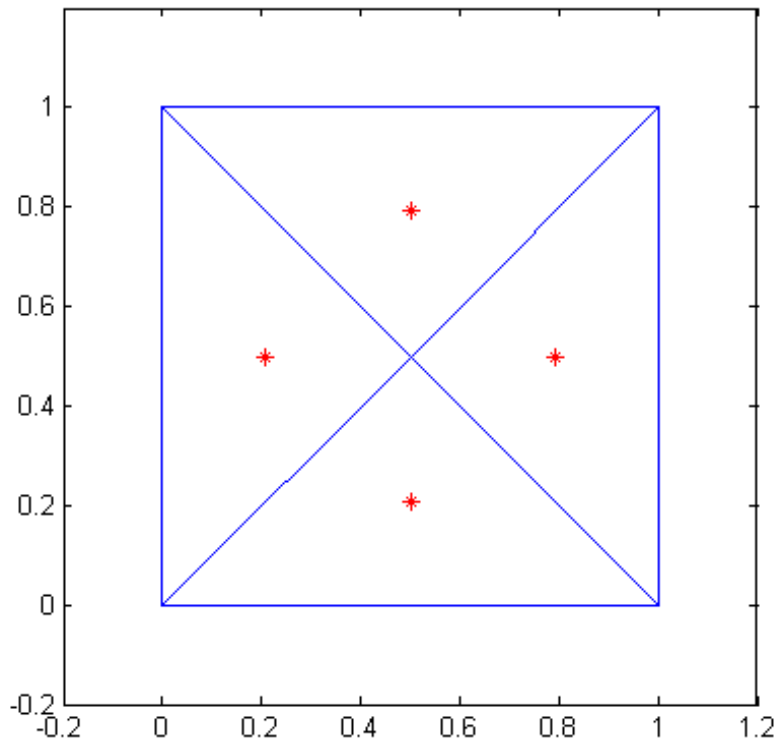

# triangulation.incenter

---

## See Also

`circumcenter` | `deLaunayTriangulation`

**Purpose**

Test if two vertices are connected by edge

**Syntax**

```
tf = isConnected(TR,vstart,vend)
tf = isConnected(TR,E)
```

**Description**

`tf = isConnected(TR,vstart,vend)` returns a logical array of true or false values that indicate whether the specified pairs of vertices are connected by an edge. Element `tf(j)` is true when the vertices, `vstart(j)` and `vend(j)`, are connected by an edge.

`tf = isConnected(TR,E)` specifies the edge start and end indices in matrix `E`. Element `tf(j)` is true when the vertices, `E(j,1)` and `E(j,2)`, are connected by an edge.

**Input Arguments****TR**

Triangulation representation, see `triangulation` or `delaunayTriangulation`.

**vstart**

IDs of start vertices, specified as a column vector. Each vertex ID refers to a vertex at the start of an edge.

**vend**

IDs of end vertices, specified as a column vector. Each vertex ID refers to a vertex at the end of an edge.

**E**

IDs of the edge vertices, specified as a two-column matrix. Each row of `E` corresponds to a candidate edge and contains two IDs:

- `E(j,1)` is the ID of the vertex at the start of a candidate edge.
- `E(j,2)` is the ID of the vertex at end of the edge.

# triangulation.isConnected

---

## Output Arguments

**tf**

Logical values, returned as a column vector. Element `tf(j)` is true when either of the following are true:

- The vertices, `vstart(j)` and `vend(j)`, are connected by an edge.
- The vertices, `E(j,1)` and `E(j,2)`, are connected by an edge.

Otherwise, `tf(j)` is false.

## Definitions

### Vertex ID

A row number of the matrix, `TR.Points`. Use this ID to refer a specific vertex in the triangulation.

## Examples

### Determine Whether Vertices are connected by an Edge in 2-D

Load a 2-D triangulation.

```
load trimesh2d
TR = triangulation(tri,x,y);
```

Determine whether vertices 3 and 117 are connected by an edge.

```
isConnected(TR,3,117)
```

```
ans =
```

```
1
```

The vertices are connected by an edge.

Determine whether vertices 3 and 164 are connected by an edge.

```
isConnected(TR,3,164)
```

```
ans =
```

0

The vertices are not connected by an edge.

## Determine Whether Vertices are connected by an Edge in 3-D

```
X = gallery('uniformdata',[10,3],0);
DT = delaunayTriangulation(X);
```

Determine whether vertices 2 and 7 are connected by an edge.

```
E = [2 7];
isConnected(DT,E)
```

```
ans =
```

1

The vertices are connected by an edge.

## See Also

[edges](#) | [edgeAttachments](#) | [delaunayTriangulation](#)

# triangulation.neighbors

---

**Purpose** Neighbors to specified triangle or tetrahedron

**Syntax** `N = neighbors(TR,ti)`  
`N = neighbors(TR)`

**Description** `N = neighbors(TR,ti)` returns the neighbors of the triangles or tetrahedra specified in `ti`.  
`N = neighbors(TR)` returns the neighbors of all the triangles or tetrahedra.

**Input Arguments** **TR**  
Triangulation representation, see `triangulation` or `delaunayTriangulation`.

**ti**  
Triangle or tetrahedron IDs, specified as a column vector.

**Output Arguments** **TN**  
IDs of the neighboring triangles or tetrahedra, returned as a matrix. The elements in `TN(i,:)` are the neighbors associated with `ti(i)`.  
By convention, `TN(i,j)` is the neighbor opposite the `j`th vertex of `ti(i)`. If a triangle or tetrahedron has one or more boundary facets, the nonexistent neighbors are represented as NaN values in `TN`.

**Definitions** **Triangle or Tetrahedron ID**

A row number of the matrix, `TR.ConnectivityList`. Use this ID to refer a specific triangle or tetrahedron.

**Vertex ID**

A row number of the matrix, `TR.Points`. Use this ID to refer a specific vertex in the triangulation.

## Examples

### Query Neighbors in 2-D Delaunay Triangulation

Create a Delaunay triangulation from a set of random points.

```
x = gallery('uniformdata',[10,1],0);
y = gallery('uniformdata',[10,1],1);
DT = delaunayTriangulation(x,y);
```

Find the neighbors of the first triangle.

```
TN = neighbors(DT,1)
```

```
TN =
```

```
NaN 4 5
```

The first triangle has a boundary edge and two neighbors.

Examine the vertex IDs of the first neighbor, TN(2).

```
DT.ConnectivityList(TN(2),:)
```

```
ans =
```

```
2 4 7
```

### Query Neighbors in 3-D Triangulation

Create the Delaunay triangulation.

```
load tetmesh
TR = triangulation(tet,X);
```

Find the neighbors to each triangle in the triangulation.

```
TN = neighbors(TR);
```

Find the neighbors of the fifth tetrahedron.

```
TN(5,:)
```

# triangulation.neighbors

---

```
ans =
 2360 1539 2 1851
```

Examine the vertex IDs of the first neighbor, `TN(1)`.

```
TR.ConnectivityList(TN(1),:)
```

```
ans =
 1093 891 893 858
```

## See Also

[edgeAttachments](#) | [delaunayTriangulation](#)



<b>Purpose</b>	Size of triangulation connectivity list
<b>Syntax</b>	<code>sz = size(TR)</code>
<b>Description</b>	<code>sz = size(TR)</code> returns the size the triangulation connectivity list.
<b>Input Arguments</b>	<b>TR</b> Triangulation representation, see <code>triangulation</code> or <code>delaunayTriangulation</code> .
<b>Output Arguments</b>	<b>sz</b> Size of connectivity list, returned as a two-element row vector. The first element, <code>sz(1)</code> is the number of triangles or tetrahedra in the triangulation, and <code>sz(2)</code> is the number of vertices per triangle or tetrahedron.

## Examples **Size of 2-D Triangulation**

Create a triangulation.

```
P = [2.5 8.0
 6.5 8.0
 2.5 5.0
 6.5 5.0
 1.0 6.5
 8.0 6.5];
```

```
T = [5 3 1;
 3 2 1;
 3 4 2;
 4 6 2];
```

```
TR = triangulation(T,P);
```

Get the size of the connectivity list.

# triangulation.size

---

```
size(TR)
```

```
ans =
```

```
 4 3
```

The triangulation has 4 triangles, and each triangle has 3 vertices.

## See Also

[size](#) | [delaunayTriangulation](#)

<b>Purpose</b>	Triangles or tetrahedra attached to specified vertex
<b>Syntax</b>	<pre>ti = vertexAttachments(TR,vi) ti = vertexAttachments(TR)</pre>
<b>Description</b>	<p><code>ti = vertexAttachments(TR,vi)</code> returns the triangles or tetrahedra attached to the specified vertices, <code>vi</code>.</p> <p><code>ti = vertexAttachments(TR)</code> returns the triangles or tetrahedra attached to every vertex in the triangulation.</p>
<b>Input Arguments</b>	<p><b>TR</b></p> <p>Triangulation representation, see <code>triangulation</code> or <code>delaunayTriangulation</code>.</p> <p><b>vi</b></p> <p>Query vertices, specified as a column vector of vertex IDs.</p>
<b>Output Arguments</b>	<p><b>ti</b></p> <p>IDs of the triangles or tetrahedra attached to the vertices, returned as an <code>m</code>-by-1 cell array. Each cell in <code>ti</code> contains the IDs of the attached triangles or tetrahedra. <code>ti{j}</code> contains the attachments to the vertex, <code>vi(j)</code>. The attachments are returned in a cell array because the number of triangles or tetrahedra associated with each vertex can vary.</p>
<b>Definitions</b>	<p><b>Triangle or Tetrahedron ID</b></p> <p>A row number of the matrix, <code>TR.ConnectivityList</code>. Use this ID to refer a specific triangle or tetrahedron.</p> <p><b>Vertex ID</b></p> <p>A row number of the matrix, <code>TR.Points</code>. Use this ID to refer a specific vertex in the triangulation.</p>

# triangulation.vertexAttachments

---

## Examples

### Attachments to Specific Vertex in 2-D Delaunay Triangulation

Locate and plot the attachments to a specific vertex.

Create a Delaunay triangulation from a set of random points.

```
x = gallery('uniformdata',[20,1],0);
y = gallery('uniformdata',[20,1],1);
DT = delaunayTriangulation(x,y);
```

Find the triangles attached to the fifth vertex.

```
ti = vertexAttachments(DT,5);
ti{:}
```

```
ans =
```

```
 18 23 21 22
```

Plot the triangulation.

```
triplot(DT);
hold on;

% Plot the triangles attached to vertex 5 (in red).
triplot(DT(ti{:},:),x,y,'Color','r');
hold off;
```

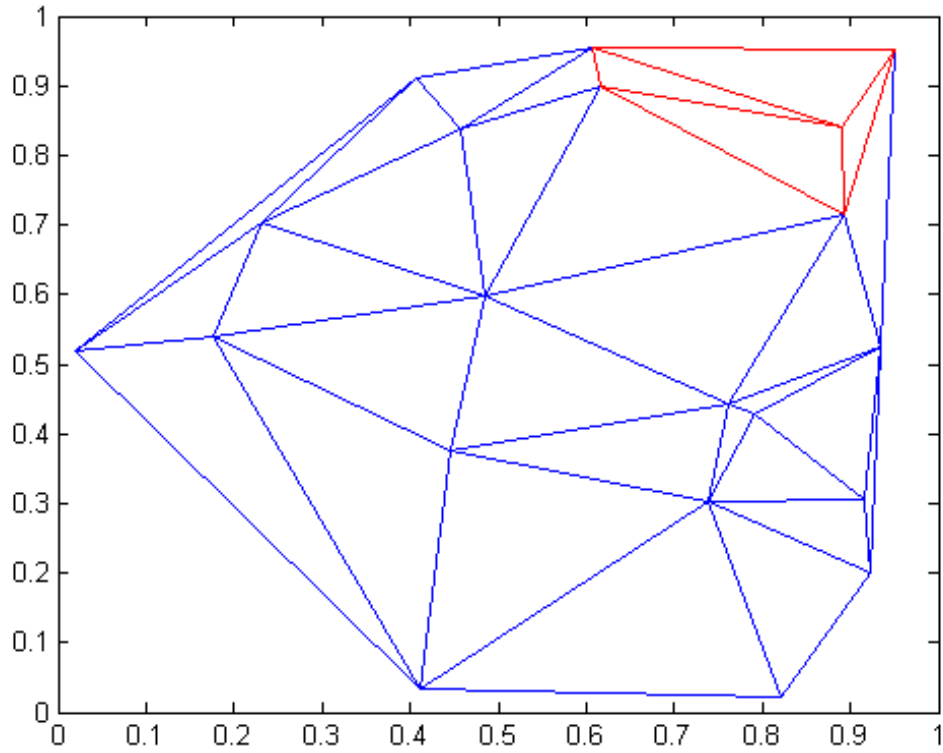

**See Also** [edgeAttachments](#) | [delaunayTriangulation](#)

# triangulation.vertexNormal

---

**Purpose** Triangulation vertex normal

**Syntax** VN = vertexNormal(TR,vi)  
VN = vertexNormal(TR)

**Description** VN = vertexNormal(TR,vi) returns the unit normal vector to each of the specified vertices in vi.  
VN = vertexNormal(TR) returns the normal information for all vertices in the triangulation.

**Input Arguments** **TR**  
Triangulation representation, see triangulation or delaunayTriangulation.

**vi**  
IDs of vertices to query, specified as a column vector. Each element in vi is a “Vertex ID” on page 1-5836.

**Output Arguments** **VN**  
Vertex normals, returned a matrix. Each row, VN(j,:), is the unit normal vector at the vertex vi(j). The vector at VN(j,:) is the average unit normal of the faces attached to vertex vi(j).  
If you do not specify vi, then vertexNormal returns the unit normal information for all vertices in the triangulation. In this case, the normal associated with TR.Points(j,:) is VN(j,:).

**Definitions** **Vertex ID**  
A row number of the matrix, TR.Points. Use this ID to refer a specific vertex in the triangulation.

**Examples** **Unit Normal Vectors to the Surface of a Cube**

Create a 3-D triangulation representing the volume of a cube.

```
[X,Y,Z] = meshgrid(1:4);
X = X(:);
Y = Y(:);
Z = Z(:);
dt = delaunayTriangulation(X,Y,Z);
```

Find the surfaces of the cube and isolate them in a 2-D triangulation.

```
[Tfb,Xfb] = freeBoundary(dt);
TR = triangulation(Tfb,Xfb);
```

Find the unit normal vectors to the triangles on the surface of the cube.

```
vn = vertexNormal(TR);
```

Plot the results.

```
trisurf(TR,'FaceColor',[0.8 0.8 1.0]);
axis equal
hold on
quiver3(Xfb(:,1),Xfb(:,2),Xfb(:,3),...
 vn(:,1),vn(:,2),vn(:,3),0.5,'color','b');
hold off
```

# triangulation.vertexNormal

---

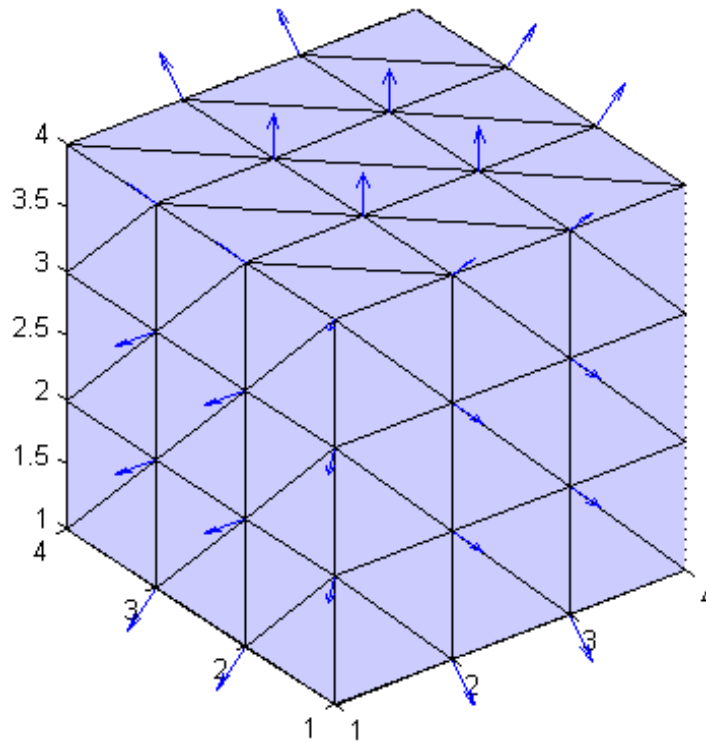

## See Also

`freeBoundary` | `deLaunayTriangulation`



**Purpose**

Create table from file

**Syntax**

```
T = readtable(filename)
T = readtable(filename,Name,Value)
```

**Description**

`T = readtable(filename)` creates a table by reading column oriented data from a file.

`readtable` determines the file format from the file name's extension:

- `.txt`, `.dat`, or `.csv` for delimited text files
- `.xls`, `.xlsb`, `.xlsm`, `.xlsx`, `.xltm`, `.xltx`, or `.ods` for spreadsheet files

`readtable` creates one variable in `T` for each column in the file and reads variable names from the first row of the file. By default, the variables created are `double` if the entire column is numeric, or cell arrays of strings if any element in a column is not numeric.

`T = readtable(filename,Name,Value)` creates a table from a file with additional options specified by one or more `Name,Value` pair arguments.

For example, you can specify not to read the first row of the file as variable names.

**Input Arguments****filename - Name of file to read**

string

Name of the file to read, specified as a string. If `filename` includes the file extension, then `readtable` determines the file format from the extension. Otherwise, you must specify the 'FileType' name-value pair arguments to indicate the type of file.

On Windows systems with Microsoft Excel software, `readtable` reads any Excel spreadsheet file format recognized by your version of Excel. If your system does not have Excel for Windows, `readtable` operates

# readtable

---

in `basic` import mode, and reads only XLS, XLSX, XLSM, XLTX, and XLTM files.

For a delimited text file, `readtable` converts empty fields in the file to either NaN (for a numeric variable) or the empty string (for a string-valued variable). All lines in the text file must have the same number of delimiters. `readtable` ignores insignificant white space in the file.

**Example:** `'myFile.xlsx'`

## **Name-Value Pair Arguments**

Specify optional comma-separated pairs of `Name`, `Value` arguments. `Name` is the argument name and `Value` is the corresponding value. `Name` must appear inside single quotes (`' '`). You can specify several name and value pair arguments in any order as `Name1, Value1, ..., NameN, ValueN`.

**Example:** `'ReadVariableNames'`, `false` indicates that the first row of the file does not correspond to variable names.

## **'FileType' - Type of file**

`'text' | 'spreadsheet'`

Type of file, specified as the comma-separated pair consisting of `'FileType'` and the string `'text'` or `'spreadsheet'`.

You must specify the `'FileType'` name-value pair argument if the filename input argument does not include the file extension or if the extension is other than one of the following.

- `.txt`, `.dat`, or `.csv` for delimited text files
- `.xls`, `.xlsb`, `.xism`, `.xlsx`, `.xlsm`, `.xltx`, or `.ods` for spreadsheet files

**Example:** `'FileType', 'text'`

## **'ReadVariableNames' - Indicator for reading first row as variable names**

`true (default) | false | 1 | 0`

Indicator for reading the first row as variable names, specified as the comma-separated pair consisting of 'ReadVariableNames' and either true, false, 1, or 0.

**true**            The first row of the region to read contains the variable names for the table. This is the default behavior.

If both the 'ReadVariableNames' and 'ReadRowNames' logical indicators are true, then readtable saves the name in the first column of the first row of the region to read as the first dimension name in the property, T.Properties.DimensionNames.

**false**            The first row of the region to read contains the first row of data in the table.

readtable creates default variable names of the form 'Var1', ..., 'VarN', where N is the number of variables.

## **'ReadRowNames' - Indicator for reading the first column as row names**

false (default) | true | 0 | 1

Indicator for reading first column as row names, specified as the comma-separated pair consisting of 'ReadRowNames' and either false, true, 0, or 1.

# readtable

---

false	The first column of the region to read contains the first variable in the table. It does not contain the row names for the table. This is the default behavior.
true	The first column of the region to read contains the row names for the table.  If both the 'ReadVariableNames' and 'ReadRowNames' logical indicators are true, then readtable saves the name in the first column of the first row of the region to read as the first dimension name in the property, T.Properties.DimensionNames.

## 'TreatAsEmpty' - Strings to treat as empty value

string | cell array of strings

Strings to treat as empty value, specified as the comma-separated pair consisting of 'TreatAsEmpty' and a string or a cell array of strings. Table elements corresponding to these are set to NaN.

'TreatAsEmpty' only applies to numeric columns in the file, and readtable does not accept numeric literals, such as '-99'.

**Example:** 'TreatAsEmpty', 'N/A' sets N/A within numeric columns to NaN.

**Example:** 'TreatAsEmpty', {'.', 'NA', 'N/A'} sets ., NA and N/A within numeric columns to NaN.

## 'Delimiter' - Field delimiter character

string

Field delimiter character, specified as the comma-separated pair consisting of 'Delimiter' and one of the following strings:

<code>' , '</code>	Comma. This is the default behavior.
<code>' comma '</code>	
<code>' ' '</code>	Space
<code>' space '</code>	
<code>' \t '</code>	Tab
<code>' tab '</code>	
<code>' ; '</code>	Semicolon
<code>' semi '</code>	
<code>'   '</code>	Vertical bar
<code>' bar '</code>	

You can use the `'Delimiter'` name-value pair only with delimited text files.

**Example:** `'Delimiter','space'`

### **'HeaderLines' - Number of lines to skip at beginning of file**

0 (default) | positive integer

Number of lines to skip at beginning of file, specified as the comma-separated pair consisting of `'HeaderLines'` and a positive integer.

You can use the `'HeaderLines'` name-value pair only with delimited text files.

### **Data Types**

single | double

### **'Format' - Format of columns in file**

string of one or more conversion specifiers

Format of the columns in the file, specified as the comma-separated pair consisting of `'Format'` and a string of one or more conversion specifiers.

By default, the variables created are either `double`, if the entire column is numeric, or cell arrays of strings, if any element in a column is not numeric.

The conversion specifiers are the same as those accepted by the `textscan` function. If you specify the 'Format' name-value pair argument, you can specify any of the name-value pair arguments accepted by the `textscan` function.

Specifying the format can significantly improve speed for some large files.

You can use the 'Format' name-value pair only with delimited text files.

## 'Sheet' - Worksheet to read

1 (default) | positive integer indicating worksheet index | string containing worksheet name

Worksheet to read, specified as the comma-separated pair consisting of 'Sheet' and a positive integer indicating the worksheet index or a string containing the worksheet name. The worksheet name string cannot contain a colon (:). To determine the names of sheets in a spreadsheet file, use `[status,sheets] = xlsfinfo(filename)`.

You can use the 'Sheet' name-value pair only with spreadsheet files.

**Example:** 'Sheet',2

## 'Range' - Rectangular portion of worksheet to read

string

Rectangular portion of the worksheet to read, specified as the comma-separated pair consisting of 'Range' and a string.

Specify the range using the syntax '*Corner1:Corner2*', where *Corner1* and *Corner2* are two opposing corners that define the region to read. For example, 'D2:H4' represents the 3-by-5 rectangular region between the two corners D2 and H4 on the worksheet. The 'Range' name-value pair argument is not case sensitive, and uses Excel A1 reference style (see Excel help).

If the spreadsheet contains figures or other nontabular information, use the 'Range' name-value pair argument to read only the tabular data. By default, `readtable` reads data from a spreadsheet contiguously out to the right-most column that contains data, including any empty columns that precede it.

You can use the 'Range' name-value pair only with spreadsheet files.

**Example:** 'Range', 'D2:H4'

### 'Basic' - Indicator for reading in basic mode

true | false | 1 | 0

Indicator for reading in basic mode, specified as the comma-separated pair consisting of 'Basic' and either true, false, 1, or 0.

basic mode is the default for systems without Excel for Windows. In basic mode, `readtable`:

- Reads XLS, XLSX, XLSM, XLTX, and XLTM files only.
- Does not support the 'Range' name-value pair argument when reading XLS files.
- Imports all dates as Excel serial date numbers. Excel serial date numbers use a different reference date than MATLAB date numbers.

You can use the 'Basic' name-value pair only with spreadsheet files.

## Output Arguments

### T - Output table

table

Output table, returned as a table. The table can store metadata such as descriptions, variable units, variable names, and row names. For more information, see [Table Properties](#).

## Examples

### Create Table from Text File

Create a file, `myCsvTable.dat`, that contains the following comma-separated column oriented data.

# readtable

---

```
LastName,Gender,Age,Height,Weight,Smoker
Smith,M,38,71,176,1
Johnson,M,43,69,163,0
Williams,F,38,64,131,0
Jones,F,40,67,133,0
Brown,F,49,64,119,0
```

Create a table from the comma-separated text file.

```
T = readtable('myCsvTable.dat')
```

```
T =
```

LastName	Gender	Age	Height	Weight	Smoker
'Smith'	'M'	38	71	176	1
'Johnson'	'M'	43	69	163	0
'Williams'	'F'	38	64	131	0
'Jones'	'F'	40	67	133	0
'Brown'	'F'	49	64	119	0

T contains one variable for each column in the file and `readtable` the entries in first line of the file as variable names.

## Create Table from Text File without Column Headings

Create a file, `mySpaceDelimTable.txt`, that contains the following space delimited, column oriented data.

```
M 45 45 NY true
F 41 32 CA false
M 40 34 MA false
```

Create a table from the space delimited text file that does not contain variable names as column headings.

```
T = readtable('mySpaceDelimTable.txt',...
 'Delimiter',' ','ReadVariableNames',false)
```



```
T =
```

Var1	Var2	Var3	Var4	Var5
'M'	45	45	'NY'	'true'
'F'	41	32	'CA'	'false'
'M'	40	34	'MA'	'false'

T contains default variable names.

### Create and Format Table from Text File

Create a file, `myCsvTable.dat`, that contains the following comma-separated column oriented data.

```
LastName,Gender,Age,Height,Weight,Smoker
Smith,M,38,71,176,1
Johnson,M,43,69,163,0
Williams,F,38,64,131,0
Jones,F,40,67,133,0
Brown,F,49,64,119,0
```

Create a table from the comma-separated text file. Format the first two variables as strings, the third variable as `uint32`, and the next two variables as double-precision, floating-point numbers. Format the last variable as a string.

```
T = readtable('myCsvTable.dat','Format','%s%s%u%f%f%s')
```

```
T =
```

LastName	Gender	Age	Height	Weight	Smoker
'Smith'	'M'	38	71	176	'1'
'Johnson'	'M'	43	69	163	'0'
'Williams'	'F'	38	64	131	'0'
'Jones'	'F'	40	67	133	'0'

# readtable

---

```
'Brown' 'F' 49 64 119 '0'
```

The conversion specifiers are %s for a cell array of strings, %f for double, and %u for uint32.

## Create Table from Spreadsheet Including Row Names

Create a table from a spreadsheet that contains variable names in the first row and row names in the first column.

```
T = readtable('patients.xls','ReadRowNames',true);
```

Display the first five rows and first four variables of the table.

```
T(1:5,1:4)
```

```
ans =
```

	Gender	Age	Location	Height
Smith	'Male'	38	'County General Hospital'	71
Johnson	'Male'	43	'VA Hospital'	69
Williams	'Female'	38	'St. Mary's Medical Center'	64
Jones	'Female'	40	'VA Hospital'	67
Brown	'Female'	49	'County General Hospital'	64

View the DimensionNames property of the table.

```
T.Properties.DimensionNames
```

```
ans =
```

```
'LastName' 'Variable'
```

'LastName' is the name in the first column of the first row of the spreadsheet.

## Read Specific Range of Data from Spreadsheet

Create a table from the 5-by-3 rectangular region between the two corners C2 and E6 on the spreadsheet `patients.xls`. Do not use the first row of this region as variable names.

```
T = readtable('patients.xls',...
 'Range','C2:E6',...
 'ReadVariableNames',false)
```

T =

Var1	Var2	Var3
38	'County General Hospital'	71
43	'VA Hospital'	69
38	'St. Mary's Medical Center'	64
40	'VA Hospital'	67
49	'County General Hospital'	64

T contains default variable names.

### See Also

`writetable` | `table` | `textscan`

### Related Examples

- “Access Data in a Table”

# real

---

**Purpose** Real part of complex number

**Syntax** `X = real(Z)`

**Description** `X = real(Z)` returns the real part of the elements of the complex array `Z`.

**Examples** `real(2+3*i)` is 2.

**See Also** `abs` | `angle` | `conj` | `i` | `j` | `imag`

**Purpose** Natural logarithm for nonnegative real arrays

**Syntax** `Y = reallog(X)`

**Description** `Y = reallog(X)` returns the natural logarithm of each element in array `X`. Array `X` must contain only nonnegative real numbers. The size of `Y` is the same as the size of `X`.

**Examples**

```
M = magic(4)

M =
 16 2 3 13
 5 11 10 8
 9 7 6 12
 4 14 15 1
```

```
reallog(M)
```

```
ans =
 2.7726 0.6931 1.0986 2.5649
 1.6094 2.3979 2.3026 2.0794
 2.1972 1.9459 1.7918 2.4849
 1.3863 2.6391 2.7081 0
```

**See Also** `log` | `realpow` | `realsqrt`

# realmax

---

**Purpose** Largest positive floating-point number

**Syntax** `n = realmax`

**Description** `n = realmax` returns the largest finite floating-point number in IEEE double precision.

`realmax('double')` is the same as `realmax` with no arguments.

`realmax('single')` returns the largest finite floating-point number in IEEE single precision.

**Examples** Find the value of the constant `realmax`:

```
ndouble = realmax
nsingle = realmax('single')
```

```
ndouble =
 1.7977e+308
```

```
nsingle =
 3.4028e+38
```

**See Also** `eps` | `realmin` | `intmax`

**Tutorials** • “Floating-Point Numbers”

**Purpose**            Smallest positive normalized floating-point number

**Syntax**            `n = realmin`  
                      `realmin('double')`  
                      `realmin('single')`

**Description**        `n = realmin` returns the smallest positive normalized floating-point number in IEEE double precision.  
  
`realmin('double')` is the same as `realmin` with no arguments.  
  
`realmin('single')` returns the smallest positive normalized floating-point number in IEEE single precision.

**Examples**            Find the value of the constant `realmin`:

```
ndouble = realmin
nsingle = realmin('single')
```

```
ndouble =
 2.2251e-308
```

```
nsingle =
 1.1755e-38
```

**See Also**            `eps` | `realmax` | `intmin`

**Tutorials**            • “Floating-Point Numbers”

# realpow

---

**Purpose** Array power for real-only output

**Syntax** `Z = realpow(X,Y)`

**Description** `Z = realpow(X,Y)` raises each element of array `X` to the power of its corresponding element in array `Y`. Arrays `X` and `Y` must be the same size. The range of `realpow` is the set of all real numbers, i.e., all elements of the output array `Z` must be real.

**Examples** `X = -2*ones(3,3)`

```
X =
 -2 -2 -2
 -2 -2 -2
 -2 -2 -2
```

```
Y = pascal(3)
```

```
ans =
 1 1 1
 1 2 3
 1 3 6
```

```
realpow(X,Y)
```

```
ans =
 -2 -2 -2
 -2 4 -8
 -2 -8 64
```

**See Also** `reallog` | `realsqrt` | `power` | `mpower`



**Purpose** Square root for nonnegative real arrays

**Syntax** `Y = realsqrt(X)`

**Description** `Y = realsqrt(X)` returns the square root of each element of array `X`. Array `X` must contain only nonnegative real numbers. The size of `Y` is the same as the size of `X`.

**Examples** `M = magic(4)`

```
M =
 16 2 3 13
 5 11 10 8
 9 7 6 12
 4 14 15 1
```

```
realsqrt(M)
```

```
ans =
 4.0000 1.4142 1.7321 3.6056
 2.2361 3.3166 3.1623 2.8284
 3.0000 2.6458 2.4495 3.4641
 2.0000 3.7417 3.8730 1.0000
```

**See Also** `reallog` | `realpow` | `sqrt` | `sqrtm`

# record

---

**Purpose** Record data and event information to file

**Syntax** `record(obj)`  
`record(obj, 'switch')`

**Description** `record(obj)` toggles the recording state for the serial port object, `obj`. `record(obj, 'switch')` initiates or terminates recording for `obj`. `switch` can be `on` or `off`. If `switch` is `on`, recording is initiated. If `switch` is `off`, recording is terminated.

**Tips** Before you can record information to disk, `obj` must be connected to the device with the `fopen` function. A connected serial port object has a `Status` property value of `open`. An error is returned if you attempt to record information while `obj` is not connected to the device. Each serial port object must record information to a separate file. Recording is automatically terminated when `obj` is disconnected from the device with `fclose`.

The `RecordName` and `RecordMode` properties are read-only while `obj` is recording, and must be configured before using `record`.

For a detailed description of the record file format and the properties associated with recording data and event information to a file, refer to [Debugging: Recording Information to Disk](#).

**Examples** This example creates the serial port object `s` on a Windows platform. It connects `s` to the device, configures `s` to record information to a file, writes and reads text data, and then disconnects `s` from the device.

```
s = serial('COM1');
fopen(s)
s.RecordDetail = 'verbose';
s.RecordName = 'MySerialFile.txt';
record(s, 'on')
fprintf(s, '*IDN?')
out = fscanf(s);
record(s, 'off')
```

`fclose(s)`

## **See Also**

`fclose` | `fopen` | `RecordDetail` | `RecordMode` | `RecordName` | `RecordStatus` | `Status`

# audiorecorder.record

---

**Purpose** Record audio to audiorecorder object

**Syntax** `record(recorderObj)`  
`record(recorderObj, length)`

**Description** `record(recorderObj)` records audio from an input device, such as a microphone connected to your system. `recorderObj` is an audiorecorder object that defines the sample rate, bit depth, and other properties of the recording.

`record(recorderObj, length)` records for the number of seconds specified by `length`.

**Examples** Record 5 seconds of your speech with a microphone:

```
myVoice = audiorecorder;

% Define callbacks to show when
% recording starts and completes.
myVoice.StartFcn = 'disp(''Start speaking.'')';
myVoice.StopFcn = 'disp(''End of recording.'')';

record(myVoice, 5);
```

To listen to the recording, call the `play` method:

```
play(myVoice);
```

**See Also** [audiorecorder](#) | [getaudiodata](#) | [recordblocking](#)

**How To**

- “Record Audio”
- “Record or Play Audio within a Function”

<b>Purpose</b>	Record audio to audiorecorder object, holding control until recording completes
<b>Syntax</b>	<code>recordblocking(recorderObj, length)</code>
<b>Description</b>	<code>recordblocking(recorderObj, length)</code> records audio from an input device, such as a microphone connected to your system, for the number of seconds specified by <i>length</i> . The <code>recordblocking</code> method does not return control until recording completes. <i>recorderObj</i> is an audiorecorder object that defines the sample rate, bit depth, and other properties of the recording.
<b>Examples</b>	Record 5 seconds of your speech with a microphone, and play it back:  <pre>myVoice = audiorecorder;  disp('Start speaking.');</pre> <code>recordblocking(myVoice, 5);</code> <pre>disp('End of recording. Playing back ...');</pre> <pre>play(myVoice);</pre>
<b>See Also</b>	<code>audiorecorder</code>   <code>getaudiodata</code>   <code>record</code>
<b>How To</b>	<ul style="list-style-type: none"><li>• “Record Audio”</li></ul>

# rectangle

---

**Purpose** Create 2-D rectangle object

**Syntax**

```
rectangle
rectangle('Position',[x,y,w,h])
rectangle('Curvature',[x,y])
rectangle('PropertyName',propertyvalue,...)
h = rectangle(...)
```

**Properties** For a list of properties, see Rectangle Properties.

**Description** `rectangle` draws a rectangle with Position `[0,0,1,1]` and Curvature `[0,0]` (i.e., no curvature).

`rectangle('Position',[x,y,w,h])` draws the rectangle from the point `x,y` and having a width of `w` and a height of `h`. Specify values in axes data units.

Note that, to display a rectangle in the specified proportions, you need to set the axes data aspect ratio so that one unit is of equal length along both the `x` and `y` axes. You can do this with the command `axis equal` or `daspect([1,1,1])`.

`rectangle('Curvature',[x,y])` specifies the curvature of the rectangle sides, enabling it to vary from a rectangle to an ellipse. The horizontal curvature `x` is the fraction of width of the rectangle that is curved along the top and bottom edges. The vertical curvature `y` is the fraction of the height of the rectangle that is curved along the left and right edges.

The values of `x` and `y` can range from 0 (no curvature) to 1 (maximum curvature). A value of `[0,0]` creates a rectangle with square sides. A value of `[1,1]` creates an ellipse. If you specify only one value for Curvature, then the same length (in axes data units) is curved along both horizontal and vertical sides. The amount of curvature is determined by the shorter dimension.

`rectangle('PropertyName',propertyvalue,...)` draws the rectangle using the values for the property name/property value pairs specified and default values for all other properties. For a description of the properties, see Rectangle Properties.

`h = rectangle(...)` returns the handle of the rectangle object created.

## Tips

Rectangle objects are 2-D and can be drawn in an axes only if the view is `[0 90]` (i.e., `view(2)`). Rectangles are children of axes and are defined in coordinates of the axes data.

## Examples

This example sets the data aspect ratio to `[1,1,1]` so that the rectangle is displayed in the specified proportions (`daspect`). Note that the horizontal and vertical curvature can be different. Also, note the effects of using a single value for `Curvature`.

```
rectangle('Position',[0.59,0.35,3.75,1.37],...
 'Curvature',[0.8,0.4],...
 'LineWidth',2,'LineStyle','--')
daspect([1,1,1])
```

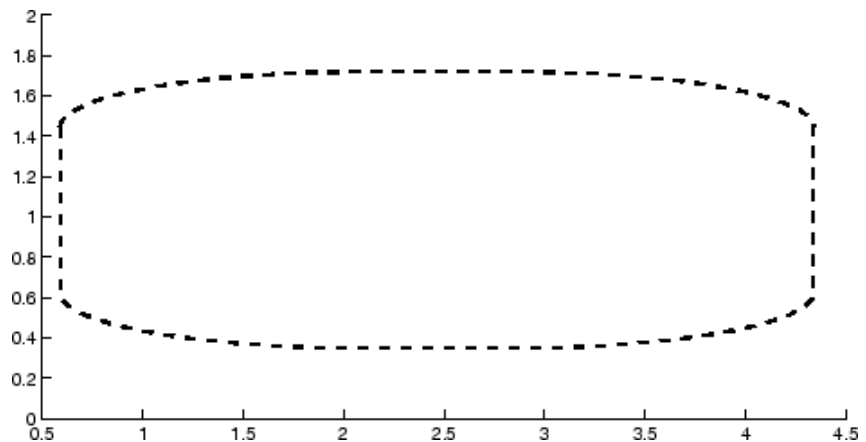

Specifying a single value of `[0.4]` for `Curvature` produces

# rectangle

---

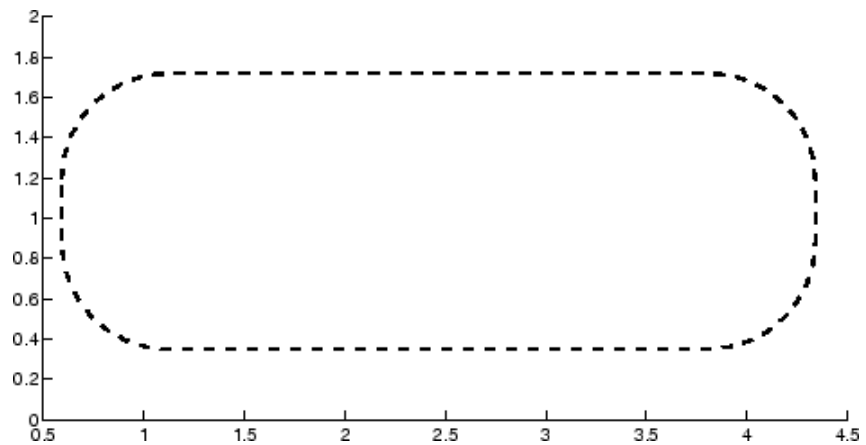

A Curvature of [1] produces a rectangle with the shortest side completely round:

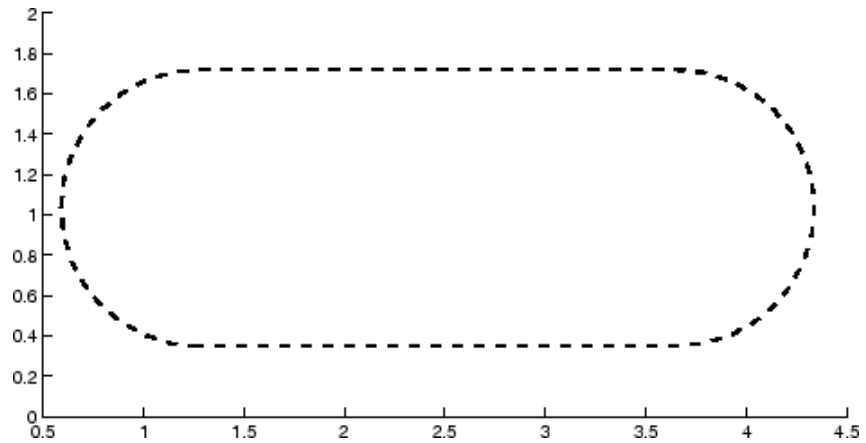

This example creates an ellipse and colors the face red.

```
rectangle('Position',[1,2,5,10],'Curvature',[1,1],...
 'FaceColor','r')
daspect([1,1,1])
xlim([0,7])
```



```
ylim([1,13])
```

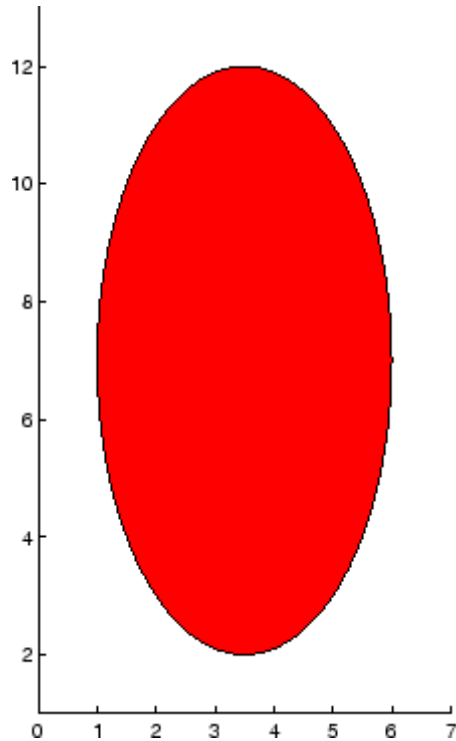

## Setting Default Properties

You can set default rectangle properties on the axes, figure, and root object levels:

```
set(0, 'DefaultRectangleProperty', PropertyValue...)
set(gcf, 'DefaultRectangleProperty', PropertyValue...)
set(gca, 'DefaultRectangleProperty', PropertyValue...)
```

where *Property* is the name of the rectangle property whose default value you want to set and *PropertyValue* is the value you are specifying. Use `set` and `get` to access the surface properties.

# rectangle

---

## **See Also**

[line](#) | [patch](#) | [annotation](#) | [Rectangle Properties](#)

## Purpose

Define rectangle properties

## Creating Rectangle Objects

Use `rectangle` to create rectangle objects.

## Modifying Properties

You can set and query graphics object properties in two ways:

- “Customize Objects in Graph” is an interactive tool that enables you to see and change object property values.
- The `set` and `get` commands enable you to set and query the values of properties.

To change the default values of properties, see “Setting Default Property Values”.

See “Core Graphics Objects” for general information about this type of object.

## Rectangle Property Descriptions

This section provides a description of properties. Curly braces { } enclose default values.

### Annotation

`hg.Annotation` object (read-only)

*Handle of Annotation object.* The `Annotation` property enables you to specify whether this rectangle object is represented in a figure legend.

Querying the `Annotation` property returns the handle of an `hg.Annotation` object. The `hg.Annotation` object has a property called `LegendInformation`, which contains an `hg.LegendEntry` object.

Once you have obtained the `hg.LegendEntry` object, you can set its `IconDisplayStyle` property to control whether the rectangle object is displayed in a figure legend:

# Rectangle Properties

---

<b>IconDisplayStyle Value</b>	<b>Purpose</b>
on	Represent this rectangle object in a legend (default)
off	Do not include this rectangle object in a legend
children	Same as on because rectangle objects do not have children

## Setting the IconDisplayStyle property

Set the `IconDisplayStyle` of a graphics object with handle `hobj` to `off`:

```
hAnnotation = get(hobj, 'Annotation');
hLegendEntry = get(hAnnotation, 'LegendInformation');
set(hLegendEntry, 'IconDisplayStyle', 'off')
```

## Using the IconDisplayStyle property

See “Control Legend Content” for more information and examples.

`BeingDeleted`  
on | {off} (read-only)

*This object is being deleted.* Mechanism to determine if objects are in the process of being deleted. MATLAB sets the `BeingDeleted` property to `on` when the object’s delete function callback is called (see the `DeleteFcn` property). It remains set to `on` while the delete function executes, after which the object no longer exists.

For example, an object’s delete function calls other functions that act on a number of different objects. If a function does not need to perform an action on an about-to-be-deleted object, it can check the object’s `BeingDeleted` property before acting.

**BusyAction**  
cancel | {queue}

### *Callback queuing*

Determines how MATLAB handles the execution of interrupting callbacks.

A *running* callback is the currently executing callback. The *interrupting* callback is the callback that tries to interrupt the *running* callback. The **BusyAction** property of the *interrupting* callback determines how MATLAB handles its execution. When the **BusyAction** property is set to:

- 'queue' — Puts the *interrupting* callback in a queue to be processed after the *running* callback finishes execution.
- 'cancel' — Discards the *interrupting* callback as MATLAB finishes execution.

For information about how the **Interruptible** property of the callback controls whether other callbacks can interrupt the *running* callback, see the **Interruptible** property description.

**ButtonDownFcn**  
function handle | cell array containing function handle and additional arguments | string (not recommended)

*Button press callback function.* Executes whenever you press a mouse button while the pointer is over the rectangle object.

See the figure's **SelectionType** property to determine if modifier keys were also pressed.

Set this property to a function handle that references the callback. The function must define at least two input arguments (handle of object associated with the button down event and an event structure, which is empty for this property).

# Rectangle Properties

---

The following example shows how to access the callback object's handle as well as the handle of the figure that contains the object from the callback function.

```
function button_down(src, evnt)
% src - the object that is the source of the event
% evnt - empty for this property
 sel_typ = get(gcf, 'SelectionType')
 switch sel_typ
 case 'normal'
 disp('User clicked left-mouse button')
 set(src, 'Selected', 'on')
 case 'extend'
 disp('User did a shift-click')
 set(src, 'Selected', 'on')
 case 'alt'
 disp('User did a control-click')
 set(src, 'Selected', 'on')
 set(src, 'SelectionHighlight', 'off')
 end
end
```

Suppose `h` is the handle of a rectangle object and the `button_down` function is on your MATLAB path. The following statement assigns the `button_down` function to the `ButtonDownFcn` property:

```
set(h, 'ButtonDownFcn', @button_down)
```

For information on the syntax of callback functions, see [Function Handle Callbacks](#).

**Children**  
vector of handles

The empty matrix; rectangle objects have no children.

**Clipping**  
{on} | off

*Clipping mode.* MATLAB clips rectangles to the axes plot box by default. If you set `Clipping` to `off`, rectangles are displayed outside the axes plot box. This can occur if you create a rectangle, set `hold` to `on`, freeze axis scaling (`axis` set to `manual`), and then create a larger rectangle.

## CreateFcn

function handle | cell array containing function handle and additional arguments | string (not recommended)

*Callback function executed during object creation.* Executes when MATLAB creates a rectangle object. You must define this property as a default value for rectangles or in a call to the `rectangle` function to create a new rectangle object. For example, the statement:

```
set(0,'DefaultRectangleCreateFcn',@rect_create)
```

defines a default value for the rectangle `CreateFcn` property on the root level that sets the axes `DataAspectRatio` whenever you create a rectangle object. The callback function must be on your MATLAB path when you execute the above statement.

```
function rect_create(src,evnt)
% src - the object that is the source of the event
% evnt - empty for this property
 axh = get(src,'Parent');
 set(axh,'DataAspectRatio',[1,1,1])
end
```

MATLAB executes this function after setting all rectangle properties. Setting this property on an existing rectangle object has no effect. The function must define at least two input arguments (handle of object created and an event structure, which is empty for this property).

The handle of the object whose `CreateFcn` is being executed is passed by MATLAB as the first argument to the callback function

# Rectangle Properties

---

and is also accessible through the root `CallbackObject` property, which you can query using `gcbo`.

For information on the syntax of callback functions, see [Function Handle Callbacks](#).

## Curvature

one- or two-element vector [x,y]

*Amount of horizontal and vertical curvature.* Specifies the curvature of the rectangle sides, which enables the shape of the rectangle to vary from rectangular to ellipsoidal. The horizontal curvature `x` is the fraction of width of the rectangle that is curved along the top and bottom edges. The vertical curvature `y` is the fraction of the height of the rectangle that is curved along the left and right edges.

The values of `x` and `y` can range from 0 (no curvature) to 1 (maximum curvature). A value of [0,0] creates a rectangle with square sides. A value of [1,1] creates an ellipse. If you specify only one value for `Curvature`, then the same length (in axes data units) is curved along both horizontal and vertical sides. The amount of curvature is determined by the shorter dimension.

## DeleteFcn

function handle | cell array containing function handle and additional arguments | string (not recommended)

*Delete rectangle callback function.* Executes when you delete the rectangle object (for example, when you issue a `delete` command or clear the axes `cla` or figure `clf`).

For example, the following function displays object property data before the object is deleted.

```
function delete_fcn(src,evnt)
% src - the object that is the source of the event
% evnt - empty for this property
```



```
obj_tp = get(src,'Type');
disp([obj_tp, ' object deleted'])
disp('Its user data is:')
disp(get(src,'UserData'))
end
```

MATLAB executes the function before deleting the object's properties so these values are available to the callback function. The function must define at least two input arguments (handle of object being deleted and an event structure, which is empty for this property).

The handle of the object whose `DeleteFcn` is being executed is passed by MATLAB as the first argument to the callback function and is also accessible through the root `CallbackObject` property, which you can query using `gcbo`.

For information on the syntax of callback functions, see [Function Handle Callbacks](#).

**DisplayName**  
string

*String used by legend.* The `legend` function uses the `DisplayName` property to label the rectangle object in the legend. The default is an empty string.

- If you specify string arguments with the `legend` function, MATLAB set `DisplayName` to the corresponding string and uses that string for the legend.
- If `DisplayName` is empty, `legend` creates a string of the form, `['data' n]`, where `n` is the number assigned to the object based on its location in the list of legend entries. However, `legend` does not set `DisplayName` to this string.
- If you edit the string directly in an existing legend, MATLAB set `DisplayName` to the edited string.

# Rectangle Properties

---

- If you specify a string for the `DisplayName` property and create the legend using the figure toolbar, then MATLAB uses the string defined by `DisplayName`.
- To add a legend programmatically that uses the `DisplayName` string, call `legend` with the `toggle` or `show` option.

See “Control Legend Content” for more information and examples.

## EdgeColor

`{ColorSpec} | none`

*Color of the rectangle edges.* Specifies the color of the rectangle edges as a color or specifies that no edges be drawn.

## EraseMode

`{normal} | none | xor | background`

*Erase mode.* Controls the technique MATLAB uses to draw and erase rectangle objects. Use alternative erase modes for creating animated sequences, where control of the way individual objects are redrawn is necessary to improve performance and obtain the desired effect.

- `normal` — Redraw the affected region of the display, performing the three-dimensional analysis necessary to ensure that all objects are rendered correctly. This mode produces the most accurate picture, but is the slowest. The other modes are faster, but do not perform a complete redraw and are therefore less accurate.
- `none` — Do not erase the rectangle when it is moved or destroyed. While the object is still visible on the screen after erasing with `EraseMode none`, you cannot print it because MATLAB stores no information about its former location.
- `xor` — Draw and erase the rectangle by performing an exclusive OR (XOR) with the color of the screen beneath it. This mode does not damage the color of the objects beneath the rectangle.

However, the rectangle's color depends on the color of whatever is beneath it on the display.

- **background** — Erase the rectangle by drawing it in the axes background `Color`, or the figure background `Color` if the axes `Color` is none. This damages objects that are behind the erased rectangle, but rectangles are always properly colored.

## Printing with Nonnormal Erase Modes

MATLAB always prints figures as if the `EraseMode` of all objects is `normal`. This means graphics objects created with `EraseMode` set to `none`, `xor`, or `background` can look different on screen than on paper. On screen, MATLAB mathematically combines layers of colors (for example, performing an XOR on a pixel color with that of the pixel behind it) and ignore three-dimensional sorting to obtain greater rendering speed. However, these techniques are not applied to the printed output.

You can use the `getframe` command or other screen capture applications to create an image of a figure containing nonnormal mode objects.

`FaceColor`  
`ColorSpec` | `{none}`

*Color of rectangle face.* Specifies the color of the rectangle face, which is not colored by default.

`HandleVisibility`  
`{on}` | `callback` | `off`

*Control access to object's handle.* Determines when an object's handle is visible in its parent's list of children. `HandleVisibility` is useful for preventing command-line users from accidentally drawing into or deleting a figure that contains only user interface devices (such as a dialog box).

- `on` — Handles are always visible.

# Rectangle Properties

---

- `callback` — Handles are visible from within callback routines or functions invoked by callback routines, but not from within functions invoked from the command line. This provides a means to protect GUIs from command-line users, while allowing callback routines to have access to object handles.
- `off` — Handles are invisible at all times. Use this option when a callback invokes a function that could damage the GUI (such as evaluating a user-typed string). This option temporarily hides its own handles during the execution of that function.

When a handle is not visible in its parent's list of children, it cannot be returned by functions that obtain handles by searching the object hierarchy or querying handle properties. This includes `get`, `findobj`, `gca`, `gcf`, `gco`, `newplot`, `cla`, `clf`, and `close`.

When a handle's visibility is restricted using `callback` or `off`, the object's handle does not appear in its parent's `Children` property, figures do not appear in the root's `CurrentFigure` property, objects do not appear in the root's `CallbackObject` property or in the figure's `CurrentObject` property, and axes do not appear in their parent's `CurrentAxes` property.

You can set the `Root ShowHiddenHandles` property to `on` to make all handles visible regardless of their `HandleVisibility` settings (this does not affect the values of the `HandleVisibility` properties).

Handles that are hidden are still valid. If you know an object's handle, you can `set` and `get` its properties and pass it to any function that operates on handles.

`HitTest`  
{on} | off

*Selectable by mouse click.* Determines if the rectangle can become the current object (as returned by the `gco` command and the figure `CurrentObject` property) as a result of a mouse click on the

rectangle. If `HitTest` is off, clicking the rectangle selects the object below it (which might be the axes containing it).

## Interruptible

off | {on}

### *Callback routine interruption*

Controls whether MATLAB can interrupt an object's callback function when subsequent callbacks attempt to interrupt it.

For Graphics objects, the `Interruptible` property affects only the callbacks for the `ButtonDownFcn` property. A *running* callback is the currently executing callback. The *interrupting* callback is the callback that tries to interrupt the *running* callback. MATLAB handles both the callbacks based on the `Interruptible` property of the object of the *running* callback.

When the `Interruptible` property is set to:

- 'off', MATLAB finishes execution of the *running* callback without any interruptions
- 'on', these conditions apply:
  - If there is a `drawnow`, `figure`, `getframe`, `waitfor`, or `pause` command in the *running* callback, then MATLAB executes the *interrupting* callbacks which are already in the queue and returns to finish execution of the current callback.
  - If one of the above functions is not in the *running* callback, then MATLAB finishes execution of the current callback without any interruption.

`BusyAction` property of the object of interrupting callback determines whether the callback should be ignored or should be put in the queue.

# Rectangle Properties

---

Setting `Interruptible` property to on (default), allows a callback from other graphics objects to interrupt callback functions originating from this object.

---

**Note** MATLAB does not save the state of properties or the display when an interruption occurs. For example, the handle returned by the `gca` or `gcf` command may be changed as another callback is executed.

---

After the function that interrupts a callback completes, the callback resumes execution where it halted when interrupted. For more information, see “Control Callback Execution and Interruption”.

## LineStyle

{-} | -- | : | -. | none

*Line style of rectangle edge.*

## Line Style Specifiers Table

Specifier	Line Style
'-'	Solid line (default)
'--'	Dashed line
':'	Dotted line
'-.'	Dash-dot line
'none'	No line

## LineWidth

size in points

*Width of the rectangle edge line.* Specify this value in points. 1 point =  $\frac{1}{72}$  inch. The default value is 0.5 points.

## Parent

handle of axes, hgroup, or hgtransform

*Parent of rectangle object.* Contains the handle of the rectangle object's parent. The parent of a rectangle object is the axes, hgroup, or hgtransform object that contains it.

## Position

four-element vector [x,y,width,height]

*Location and size of rectangle.* Specifies the location and size of the rectangle in the data units of the axes. The point defined by x, y specifies one corner of the rectangle, and width and height define the size in units along the x- and y-axes respectively.

## Selected

on | off

*Is object selected?* When this property is on MATLAB displays selection handles if the SelectionHighlight property is also on. You can, for example, define the ButtonDownFcn to set this property, allowing users to select the object with the mouse.

## SelectionHighlight

{on} | off

*Objects are highlighted when selected.* When the Selected property is on, MATLAB indicates the selected state by drawing handles at each vertex. When SelectionHighlight is off, MATLAB does not draw the handles.

## Tag

string

*User-specified object label.* Provides a means to identify graphics objects with a user-specified label. The default is an empty string.

Use the Tag property and the findobj function to manipulate specific objects within a plotting hierarchy.

# Rectangle Properties

---

## Type

string (read-only)

*Class of graphics object.* String that identifies the class of the graphics object. Use this property to find all objects of a given type within a plotting hierarchy. For rectangle objects, Type is always 'rectangle'.

## UIContextMenu

handle of uicontextmenu object

*Associate a context menu with the rectangle.* Assign this property the handle of a uicontextmenu object created in the same figure as the rectangle. Use the uicontextmenu function to create the context menu. MATLAB displays the context menu whenever you right-click over the rectangle.

## UserData

matrix

*User-specified data.* Data you want to associate with the rectangle object. The default value is an empty array. MATLAB does not use this data, but you can access it using the set and get commands.

## Visible

{on} | off

*Rectangle visibility.* By default, all rectangles are visible. When set to off, the rectangle is not visible, but still exists, and you can get and set its properties.

## See Also

rectangle



**Purpose** Rectangle intersection area

**Syntax** `area = rectint(A,B)`

**Description** `area = rectint(A,B)` returns the area of intersection of the rectangles specified by position vectors `A` and `B`.

If `A` and `B` each specify one rectangle, the output `area` is a scalar.

`A` and `B` can also be matrices, where each row is a position vector. `area` is then a matrix giving the intersection of all rectangles specified by `A` with all the rectangles specified by `B`. That is, if `A` is `n`-by-4 and `B` is `m`-by-4, then `area` is an `n`-by-`m` matrix where `area(i,j)` is the intersection area of the rectangles specified by the `i`th row of `A` and the `j`th row of `B`.

---

**Note** A position vector is a four-element vector `[x,y,width,height]`, where the point defined by `x` and `y` specifies one corner of the rectangle, and `width` and `height` define the size in units along the `x` and `y` axes respectively.

---

**See Also** `polyarea`

# recycle

---

**Purpose** Set option to move deleted files to recycle folder

**Syntax** `status = recycle`  
`oldState = recycle(state)`

**Description** `status = recycle` returns the current state for recycling files you remove using the `delete` function. When `status` is `off`, the `delete` function permanently removes the files. When `status` is `on`, deleted files move to a different location. For details, see the Tips section.

`oldState = recycle(state)` sets the recycle option for MATLAB to the specified state, either `on` or `off`. The `previousStat` value is the recycle state before running the statement.

## Input Arguments

### **state - State of recycle option**

`'on' | 'off'`

State of the recycle option, specified as `'on'` or `'off'`.

## Examples

### **View Current Recycling State**

Start from a state where file recycling is `off`. Verify the current recycle state.

```
state = recycle
```

```
state =
```

```
off
```

### **Turn File Recycling On**

Turn file recycling `on`. Then, delete an existing file and move it to the recycle bin or temporary folder.

```
recycle('on');
delete('myfile.txt')
```

## Tips

- The location for storing recycled files varies by platform, as follows:
  - Microsoft Windows systems — Recycle bin.
  - Apple Macintosh systems — Trash.
  - Linux systems — Subfolder with the prefix `MATLAB_Files_` in the system temporary folder, as returned by the `tempdir` function.
- The general preference for **Deleting files** sets the state of the `recycle` function at startup. When you change the preference, it changes the state of `recycle`. However, when you change the state of `recycle`, it does not change the preference.

## See Also

`delete` | `dir` | `ls` | `rmdir`

## Concepts

- “General Preferences”

# reducepatch

---

**Purpose** Reduce number of patch faces

**Syntax**

```
reducepatch(p,r)
nfv = reducepatch(p,r)
nfv = reducepatch(fv,r)
nfv = reducepatch(p)
nfv = reducepatch(fv)
reducepatch(...,'fast')
reducepatch(...,'verbose')
nfv = reducepatch(f,v,r)
[nf,nv] = reducepatch(...)
```

**Description** `reducepatch(p,r)` reduces the number of faces of the patch identified by handle `p`, while attempting to preserve the overall shape of the original object. The MATLAB software interprets the reduction factor `r` in one of two ways depending on its value:

- If `r` is less than 1, `r` is interpreted as a fraction of the original number of faces. For example, if you specify `r` as 0.2, then the number of faces is reduced to 20% of the number in the original patch.
- If `r` is greater than or equal to 1, then `r` is the target number of faces. For example, if you specify `r` as 400, then the number of faces is reduced until there are 400 faces remaining.

`nfv = reducepatch(p,r)` returns the reduced set of faces and vertices but does not set the `Faces` and `Vertices` properties of patch `p`. The struct `nfv` contains the faces and vertices after reduction.

`nfv = reducepatch(fv,r)` performs the reduction on the faces and vertices in the struct `fv`.

`nfv = reducepatch(p)` and `nfv = reducepatch(fv)` uses a reduction value of 0.5.

`reducepatch(...,'fast')` assumes the vertices are unique and does not compute shared vertices.

`reducepatch(...,'verbose')` prints progress messages to the command window as the computation progresses.

`nfv = reducepatch(f,v,r)` performs the reduction on the faces in `f` and the vertices in `v`.

`[nf,nv] = reducepatch(...)` returns the faces and vertices in the arrays `nf` and `nv`.

## Tips

If the patch contains nonshared vertices, MATLAB computes shared vertices before reducing the number of faces. If the faces of the patch are not triangles, MATLAB triangulates the faces before reduction. The faces returned are always defined as triangles.

The number of output triangles may not be exactly the number specified with the reduction factor argument (`r`), particularly if the faces of the original patch are not triangles.

## Examples

This example illustrates the effect of reducing the number of faces to only 15% of the original value.

```
[x,y,z,v] = flow;
p = patch(isosurface(x,y,z,v,-3));
set(p,'facecolor','w','EdgeColor','b');
daspect([1,1,1])
view(3)
figure;
h = axes;
p2 = copyobj(p,h);
reducepatch(p2,0.15)
daspect([1,1,1])
view(3)
```

# reducepatch

---

Before Reduction

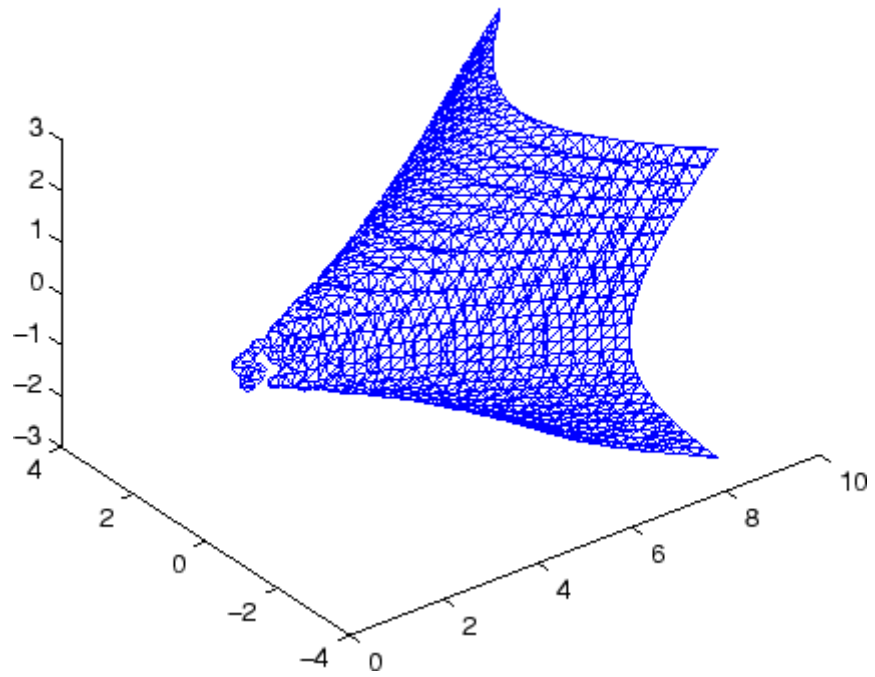

After Reduction to 15% of Original Number of Faces

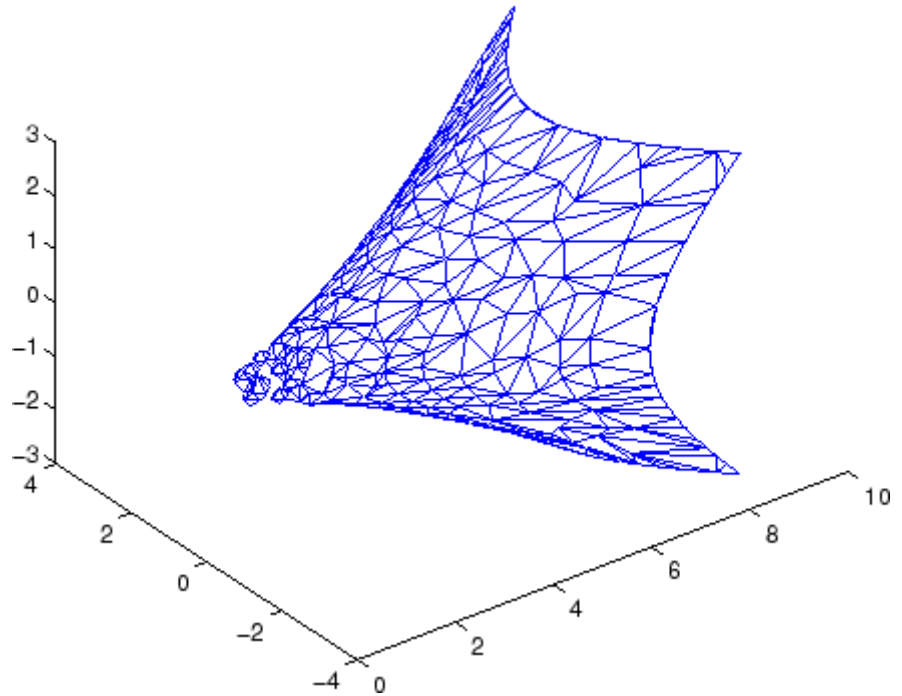

## See Also

[isosurface](#) | [isocaps](#) | [isonormals](#) | [smooth3](#) | [subvolume](#) | [reducevolume](#)

## How To

- [Vector Field Displayed with Cone Plots](#)

# reducevolume

---

**Purpose** Reduce number of elements in volume data set

**Syntax**  
`[nx,ny,nz,nv] = reducevolume(X,Y,Z,V,[Rx,Ry,Rz])`  
`[nx,ny,nz,nv] = reducevolume(V,[Rx,Ry,Rz])`  
`nv = reducevolume(...)`

**Description** `[nx,ny,nz,nv] = reducevolume(X,Y,Z,V,[Rx,Ry,Rz])` reduces the number of elements in the volume by retaining every  $R_x^{\text{th}}$  element in the  $x$  direction, every  $R_y^{\text{th}}$  element in the  $y$  direction, and every  $R_z^{\text{th}}$  element in the  $z$  direction. If a scalar  $R$  is used to indicate the amount or reduction instead of a three-element vector, the MATLAB software assumes the reduction to be `[R R R]`.

The arrays  $X$ ,  $Y$ , and  $Z$  define the coordinates for the volume  $V$ . The reduced volume is returned in  $nv$ , and the coordinates of the reduced volume are returned in  $nx$ ,  $ny$ , and  $nz$ .

`[nx,ny,nz,nv] = reducevolume(V,[Rx,Ry,Rz])` assumes the arrays  $X$ ,  $Y$ , and  $Z$  are defined as `[X,Y,Z] = meshgrid(1:n,1:m,1:p)`, where `[m,n,p] = size(V)`.

`nv = reducevolume(...)` returns only the reduced volume.

## Examples

This example uses a data set that is a collection of MRI slices of a human skull. This data is processed in a variety of ways:

- The 4-D array is squeezed (`squeeze`) into three dimensions and then reduced (`reducevolume`) so that what remains is every fourth element in the  $x$  and  $y$  directions and every element in the  $z$  direction.
- The reduced data is smoothed (`smooth3`).
- The outline of the skull is an isosurface generated as a patch (`p1`) whose vertex normals are recalculated to improve the appearance when lighting is applied (`patch`, `isosurface`, `isonormals`).
- A second patch (`p2`) with an interpolated face color draws the end caps (`FaceColor`) `isocaps`).
- The view of the object is set (`view`, `axis`, `daspect`).



- A 100-element grayscale colormap provides coloring for the end caps (colormap).
- Adding a light to the right of the camera illuminates the object (camlight, lighting).

```
load mri
D = squeeze(D);
[x,y,z,D] = reducevolume(D,[4,4,1]);
D = smooth3(D);
p1 = patch(isosurface(x,y,z,D, 5,'verbose'),...
 'FaceColor','red','EdgeColor','none');
isonormals(x,y,z,D,p1);
p2 = patch(isocaps(x,y,z,D, 5),...
 'FaceColor','interp','EdgeColor','none');
view(3); axis tight; daspect([1,1,.4])
colormap(gray(100))
camlight; lighting gouraud
```

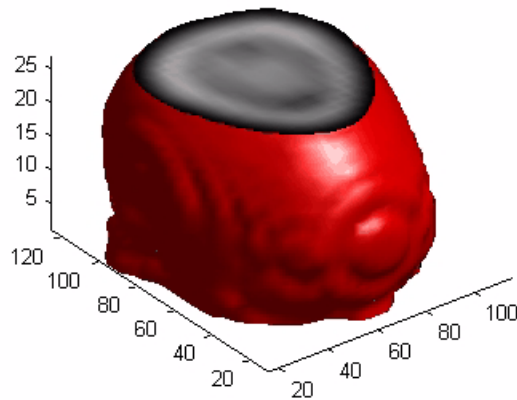

## See Also

[isosurface](#) | [isocaps](#) | [isonormals](#) | [smooth3](#) | [subvolume](#) | [reducepatch](#)

# refresh

---

**Purpose** Redraw current figure

**Syntax** refresh  
refresh(h)

**Description** refresh erases and redraws the current figure.  
refresh(h) redraws the figure identified by h.

**Purpose**

Refresh data in graph when data source is specified

**Syntax**

```
refreshdata
refreshdata(figure_handle)
refreshdata(object_handles)
refreshdata(object_handles, 'workspace')
```

**Description**

`refreshdata` evaluates any data source properties (XDataSource, YDataSource, or ZDataSource) on all objects in graphs in the current figure. If the specified data source has changed, the MATLAB software updates the graph to reflect this change.

---

**Note** The variable assigned to the data source property must be in the base workspace or you must specify the *workspace* option as '*caller*'.

---

`refreshdata(figure_handle)` refreshes the data of the objects in the specified figure.

`refreshdata(object_handles)` refreshes the data of the objects specified in *object\_handles* or the children of those objects. Therefore, *object\_handles* can contain figure, axes, or plot object handles.

`refreshdata(object_handles, 'workspace')` enables you to specify whether the data source properties are evaluated in the base workspace or the workspace of the function in which `refreshdata` was called. *workspace* is a string that can be

- `base` — Evaluate the data source properties in the base workspace.
- `caller` — Evaluate the data source properties in the workspace of the function that called `refreshdata`.

**Tips**

The Linked Plots feature (see documentation for `linkdata`) sets up data sources for graphs and synchronizes them with the workspace variables they display. When you use this feature, you do not also need to call

# refreshdata

---

refreshdata, as it is essentially automatically triggered every time a data source changes.

If you are not using the Linked Plots feature, you need to set the XDataSource, YDataSource, and/or ZDataSource properties of a graph in order to use refreshdata. You can do that programmatically, as shown in the examples below, or use the Property Editor, one of the plotting tools. In the Property Editor, select the graph (e.g., a lineseries object) and type in (or select from the drop-down choices) the name(s) of the workspace variable(s) from which you want the plot to refresh, in the fields labelled **X Data Source**, **Y Data Source**, and/or **Z Data Source**. The call to refreshdata causes the graph to update.

## Examples

### Refresh Graph with Updated Data

Plot a sine wave and return the line handle, h.

```
x = linspace(0,8);
y = sin(x);
figure
h = plot(x,y);
```

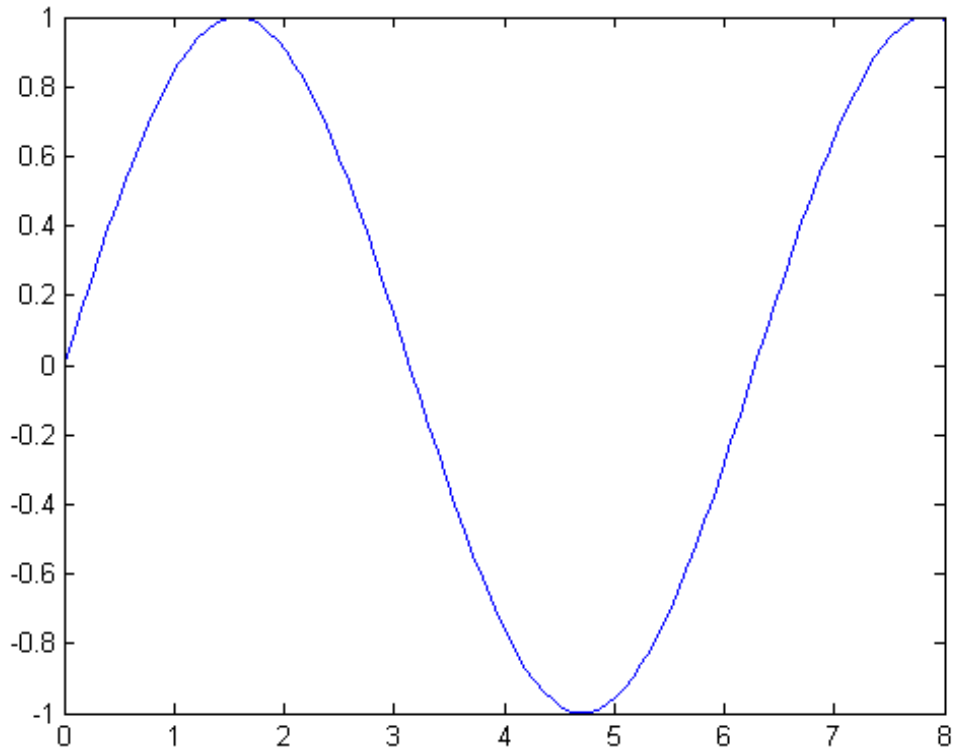

Identify the data sources for the plot by setting the `XDataSource` and `YDataSource` properties of the line to `x` and `y`, respectively. Then, modify `y`. Call `refreshdata` so that the graph updates with the changes to `y`.

```
set(h,'XDataSource','x');
set(h,'YDataSource','y');
```

```
y = sin(x.^3);
refreshdata
```

# refreshdata

---

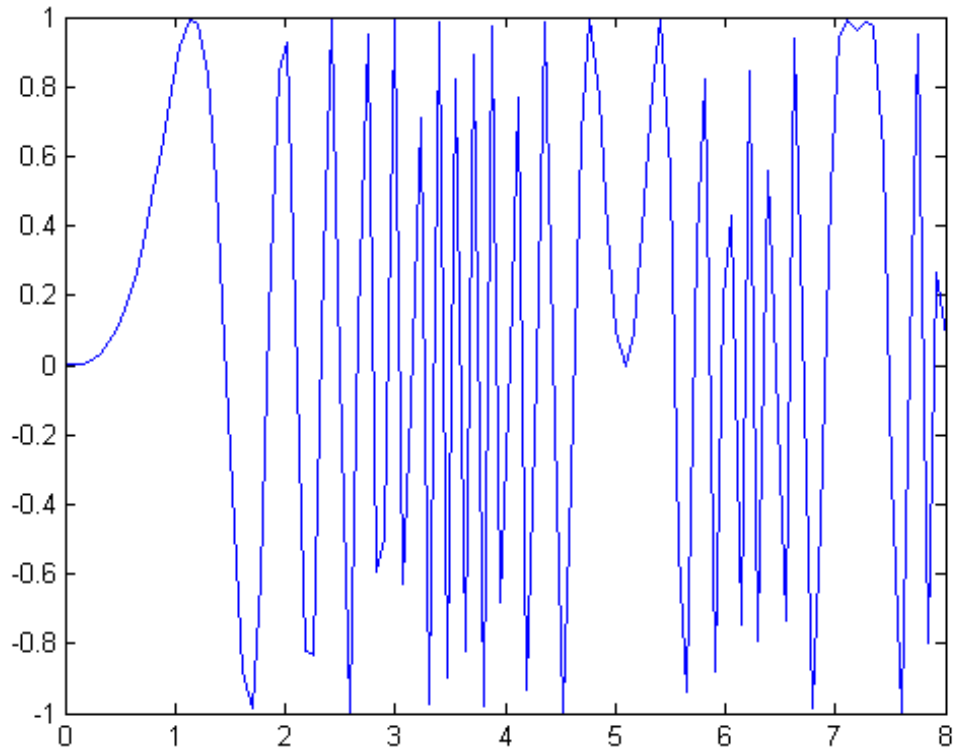

## How To

- plot objects
- “Updating Plot Object Axis and Color Data”

**Purpose**

Match regular expression (case sensitive)

**Syntax**

```
startIndex = regexp(str,expression)
[startIndex,endIndex] = regexp(str,expression)
```

```
out = regexp(str,expression,outkey)
[out1,...,outN] =
regexp(str,expression,outkey1,...,outkeyN)
```

```
___ = regexp(___,option1,...,optionM)
```

**Description**

`startIndex = regexp(str,expression)` returns the starting index of each substring of `str` that matches the character patterns specified by the regular expression. If there are no matches, `startIndex` is an empty array.

`[startIndex,endIndex] = regexp(str,expression)` returns the starting and ending indices of all matches.

`out = regexp(str,expression,outkey)` returns the output specified by `outkey`. For example, if `outkey` is 'match', then `regexp` returns the substrings that match the expression rather than their starting indices.

`[out1,...,outN] = regexp(str,expression,outkey1,...,outkeyN)` returns the outputs specified by multiple output keywords, in the specified order. For example, if you specify 'match','tokens', then `regexp` returns substrings that match the entire expression and tokens that match parts of the expression.

`___ = regexp( ___,option1,...,optionM)` modifies the search using the specified option flags. For example, specify 'ignorecase' to perform a case-insensitive match. You can include any of the inputs and request any of the outputs from previous syntaxes.

## Input Arguments

### **str - Input text**

string | cell array of strings

Input text, specified as a string or a cell array of strings. Each string can be of any length and contain any characters.

If **str** and **expression** are both cell arrays, they must have the same dimensions.

### **Data Types**

char | cell

### **expression - Regular expression**

string | cell array of strings

Regular expression, specified as a string or a cell array of strings. Each expression can contain characters, metacharacters, operators, tokens, and flags that specify patterns to match in **str**.

The following tables describe the elements of regular expressions.

### **Metacharacters**

Metacharacters represent letters, letter ranges, digits, and space characters. Use them to construct a generalized pattern of characters.

Metacharacter	Description	Example
.	Any single character, including white space	'..ain' matches sequences of five consecutive characters that end with 'ain'.
[c <sub>1</sub> c <sub>2</sub> c <sub>3</sub> ]	Any character contained within the brackets. The following characters are treated literally: \$   . * + ? and - when not used to indicate a range.	'[rp.]ain' matches 'rain' or 'pain' or '.ain'.



Metacharacter	Description	Example
<code>[^c<sub>1</sub>c<sub>2</sub>c<sub>3</sub>]</code>	Any character not contained within the brackets. The following characters are treated literally: \$   . * + ? and - when not used to indicate a range.	' <code>[^*rp]ain</code> ' matches all four-letter sequences that end in 'ain', except 'rain' and 'pain' and '*ain'. For example, it matches 'gain', 'lain', or 'vain'.
<code>[c<sub>1</sub>-c<sub>2</sub>]</code>	Any character in the range of c <sub>1</sub> through c <sub>2</sub>	' <code>[A-G]</code> ' matches a single character in the range of A through G.
<code>\w</code>	Any alphabetic, numeric, or underscore character. For English character sets, <code>\w</code> is equivalent to <code>[a-zA-Z_0-9]</code>	' <code>\w*</code> ' identifies a word.
<code>\W</code>	Any character that is not alphabetic, numeric, or underscore. For English character sets, <code>\W</code> is equivalent to <code>[^a-zA-Z_0-9]</code>	' <code>\W*</code> ' identifies a substring that is not a word.
<code>\s</code>	Any white-space character; equivalent to <code>[\f\n\r\t\v]</code>	' <code>\w*n\s</code> ' matches words that end with the letter n, followed by a white-space character.
<code>\S</code>	Any non-white-space character; equivalent to <code>[^\f\n\r\t\v]</code>	' <code>\d\S</code> ' matches a numeric digit followed by any non-white-space character.
<code>\d</code>	Any numeric digit; equivalent to <code>[0-9]</code>	' <code>\d*</code> ' matches any number of consecutive digits.
<code>\D</code>	Any nondigit character; equivalent to <code>[^0-9]</code>	' <code>\w*\D\&gt;</code> ' matches words that do not end with a numeric digit.

# regexp

Metacharacter	Description	Example
<code>\oN</code> or <code>\o{N}</code>	Character of octal value N	' <code>\o{40}</code> ' matches the space character, defined by octal 40.
<code>\xN</code> or <code>\x{N}</code>	Character of hexadecimal value N	' <code>\x2C</code> ' matches the comma character, defined by hex 2C.

## Character Representation

Operator	Description
<code>\a</code>	Alarm (beep)
<code>\b</code>	Backspace
<code>\f</code>	Form feed
<code>\n</code>	New line
<code>\r</code>	Carriage return
<code>\t</code>	Horizontal tab
<code>\v</code>	Vertical tab
<code>\char</code>	Any character with special meaning in regular expressions that you want to match literally (for example, use <code>\\</code> to match a single backslash)

## Quantifiers

Quantifiers specify the number of times a string pattern must occur in the matching string.

Quantifier	Matches the expression when it occurs...	Example
<code>expr*</code>	0 or more times consecutively.	' <code>\w*</code> ' matches a word of any length.
<code>expr?</code>	0 times or 1 time.	' <code>\w*(\.\m)?</code> ' matches words that optionally end with the extension <code>.m</code> .

Quantifier	Matches the expression when it occurs...	Example
<code>expr+</code>	1 or more times consecutively.	' <code>&lt;img src="\w+\.gif"&gt;</code> ' matches an <code>&lt;img&gt;</code> HTML tag when the file name contains one or more characters.
<code>expr{m,n}</code>	At least <code>m</code> times, but no more than <code>n</code> times consecutively. <code>{0,1}</code> is equivalent to <code>?</code> .	' <code>\S{4,8}</code> ' matches between four and eight non-white-space characters.
<code>expr{m,}</code>	At least <code>m</code> times consecutively. <code>{0,}</code> and <code>{1,}</code> are equivalent to <code>*</code> and <code>+</code> , respectively.	' <code>&lt;a href="\w{1,}\.html"&gt;</code> ' matches an <code>&lt;a&gt;</code> HTML tag when the file name contains one or more characters.
<code>expr{n}</code>	Exactly <code>n</code> times consecutively. Equivalent to <code>{n,n}</code> .	' <code>\d{4}</code> ' matches four consecutive digits.

Quantifiers can appear in three modes, described in the following table. `q` represents any of the quantifiers in the previous table.

Mode	Description	Example
<code>exprq</code>	Greedy expression: match as many characters as possible.	Given the string ' <code>&lt;tr&gt;&lt;td&gt;&lt;p&gt;text&lt;/p&gt;&lt;/td&gt;</code> ', the expression ' <code>&lt;/?t.*&gt;</code> ' matches all characters between <code>&lt;tr</code> and <code>/td&gt;</code> :  ' <code>&lt;tr&gt;&lt;td&gt;&lt;p&gt;text&lt;/p&gt;&lt;/td&gt;</code> '
<code>exprq?</code>	Lazy expression: match as few characters as necessary.	Given the string ' <code>&lt;tr&gt;&lt;td&gt;&lt;p&gt;text&lt;/p&gt;&lt;/td&gt;</code> ', the expression ' <code>&lt;/?t.*?&gt;</code> ' ends each match at the first occurrence of the closing bracket ( <code>&gt;</code> ):

# regexp

Mode	Description	Example
		'<tr>' ' <td>' '</td>'
exprq+	Possessive expression: match as much as possible, but do not rescan any portions of the string.	Given the string '<tr><td><p>text</p></td>', the expression '</?t.*+>' does not return any matches, because the closing bracket is captured using .*, and is not rescanned.

## Grouping Operators

Grouping operators allow you to capture tokens, apply one operator to multiple elements, or disable backtracking in a specific group.

Grouping Operator	Description	Example
(expr)	Group elements of the expression and capture tokens.	'Joh?n\s(\w*)' captures a token that contains the last name of any person with the first name John or Jon.
(?:expr)	Group, but do not capture tokens.	'(?:[aeiou][^aeiou]){2}' matches two consecutive patterns of a vowel followed by a nonvowel, such as 'anon'.  Without grouping, '[aeiou][^aeiou]{2}' matches a vowel followed by two nonvowels.

Grouping Operator	Description	Example
(?>expr)	Group atomically. Do not backtrack within the group to complete the match, and do not capture tokens.	'A(?>.* )Z' does not match 'AtoZ', although 'A(?:.*)Z' does. Using the atomic group, Z is captured using .* and is not rescanned.
(expr1 expr2)	Match expression expr1 or expression expr2.  If there is a match with expr1, then expr2 is ignored.  You can include ?: or ?> after the opening parenthesis to suppress tokens or group atomically.	'(let tel)\w+' matches words in a string that start with let or tel.

### Anchors

Anchors in the expression match the beginning or end of the string or word.

Anchor	Matches the...	Example
^expr	Beginning of the input string.	'^M\w*' matches a word starting with M at the beginning of the string.
expr\$	End of the input string.	'\w*m\$' matches words ending with m at the end of the string.
\<expr	Beginning of a word.	'\<n\w*' matches any words starting with n.
expr\>	End of a word.	'\w*e\>' matches any words ending with e.

### Lookaround Assertions

Lookaround assertions look for string patterns that immediately precede or follow the intended match, but are not part of the match.

# regexp

The pointer remains at the current location, and characters that correspond to the `test` expression are not captured or discarded. Therefore, lookahead assertions can match overlapping character groups.

Lookaround Assertion	Description	Example
<code>expr(?=test)</code>	Look ahead for characters that match <code>test</code> .	<code>'\w*(?=ing)'</code> matches strings that are followed by <code>ing</code> , such as <code>'Fly'</code> and <code>'fall'</code> in the input string <code>'Flying, not falling.'</code>
<code>expr(?!test)</code>	Look ahead for characters that do not match <code>test</code> .	<code>'i(?!ng)'</code> matches instances of the letter <code>i</code> that are not followed by <code>ng</code> .
<code>(?&lt;=test)expr</code>	Look behind for characters that match <code>test</code> .	<code>'(?&lt;=re)\w*'</code> matches strings that follow <code>'re'</code> , such as <code>'new'</code> , <code>'use'</code> , and <code>'cycle'</code> in the input string <code>'renew, reuse, recycle'</code>
<code>(?&lt;!test)expr</code>	Look behind for characters that do not match <code>test</code> .	<code>'(?&lt;!\d)(\d)(?!\d)'</code> matches single-digit numbers (digits that do not precede or follow other digits).

If you specify a lookahead assertion *before* an expression, the operation is equivalent to a logical AND.

Operation	Description	Example
<code>(?=test)expr</code>	Match both <code>test</code> and <code>expr</code> .	<code>'(?=[a-z])[^aeiou]'</code> matches consonants.
<code>(?!test)expr</code>	Match <code>expr</code> and do not match <code>test</code> .	<code>'(?![aeiou])[a-z]'</code> matches consonants.

## Logical and Conditional Operators

Logical and conditional operators allow you to test the state of a given condition, and then use the outcome to determine which string, if any,

to match next. These operators support logical OR, and if or if/else conditions.

Conditions can be tokens, lookahead operators, or dynamic expressions of the form (?@cmd). Dynamic expressions must return a logical or numeric value.

Conditional Operator	Description	Example
expr1 expr2	Match expression expr1 or expression expr2. If there is a match with expr1, then expr2 is ignored.	'(let tel)\w+' matches words in a string that start with let or tel.
(?(cond)expr)	If condition cond is true, then match expr.	'(?:(?@ispc)[A-Z]:\\)' matches a drive name, such as C:\, when run on a Windows system.
(?(cond)expr1 expr2)	If condition cond is true, then match expr1. Otherwise, match expr2.	'Mr(s?)\..*?(?(1)her his)\w*' matches strings that include her when the string begins with Mrs, or that include his when the string begins with Mr.

### Token Operators

Tokens are portions of the matched text that you define by enclosing part of the regular expression in parentheses. You can refer to a token by its sequence in the string (an ordinal token), or assign names to tokens for easier code maintenance and readable output.

# regexp

Ordinal Token Operator	Description	Example
(expr)	Capture in a token the characters that match the enclosed expression.	'Joh?n\s(\w*)' captures a token that contains the last name of any person with the first name John or Jon.
\N	Match the Nth token.	'<(\w+).*>.*</\1>' captures tokens for HTML tags, such as 'title' from the string '<title>Some text</title>'.
(?(N)expr1 expr2)	If the Nth token is found, then match expr1. Otherwise, match expr2.	'Mr(s?)\..*?(?(1)her his)\w*' matches strings that include her when the string begins with Mrs, or that include his when the string begins with Mr.

Named Token Operator	Description	Example
(?<name>expr)	Capture in a named token the characters that match the enclosed expression.	'(?<month>\d+)-(?<day>\d+)-(?<yr>\d+)' creates named tokens for the month, day, and year in an input date string of the form mm-dd-yy.
\k<name>	Match the token referred to by name.	'<(?(tag)\w+).*>.*</\ktag>' captures tokens for HTML tags, such as 'title' from the string '<title>Some text</title>'.
(?(name)expr1 expr2)	If the named token is found, then match expr1. Otherwise, match expr2.	'Mr(?(sex)s?)\..*?(?(sex)her his)\w*' matches strings that include her when the string begins with Mrs, or that include his when the string begins with Mr.



**Note** If an expression has nested parentheses, MATLAB captures tokens that correspond to the outermost set of parentheses. For example, given the search pattern '(and(y|rew))', MATLAB creates a token for 'andrew' but not for 'y' or 'rew'.

### Dynamic Regular Expressions

Dynamic expressions allow you to execute a MATLAB command or a regular expression to determine the text to match.

The parentheses that enclose dynamic expressions do *not* create a capturing group.

Operator	Description	Example
(??expr)	Parse expr and include the resulting string in the match expression.  When parsed, expr must correspond to a complete, valid regular expression. Dynamic expressions that use the backslash escape character (\) require two backslashes: one for the initial parsing of expr, and one for the complete match.	'^(\d+)(??\w{\$1})' determines how many characters to match by reading a digit at the beginning of the string. The dynamic expression is enclosed in a second set of parentheses so that the resulting match is captured in a token. For instance, matching '5XXXXX' captures tokens for '5' and 'XXXXX'.
(??@cmd)	Execute the MATLAB command represented by cmd, and include the string returned by the command in the match expression.	'(.{2,}).?(??@fliplr(\$1))' finds palindromes that are at least four characters long, such as 'abba'.
(?@cmd)	Execute the MATLAB command represented by cmd, but discard any output the command returns. (Helpful for diagnosing regular expressions.)	'\w*?(\\w)(?@disp(\$1))\1\w*' matches words that include double letters (such as pp), and displays intermediate results.

# regexp

---

Within dynamic expressions, use the following operators to define replacement strings.

Replacement String Operator	Description
<code>&amp;</code> or <code>\$0</code>	Portion of the input string that is currently a match
<code>\$`</code>	Portion of the input string that precedes the current match
<code>\$'</code>	Portion of the input string that follows the current match (use <code>\$'</code> to represent the string <code>\$'</code> )
<code>\$N</code>	Nth token
<code>\$&lt;name&gt;</code>	Named token
<code>\${cmd}</code>	String returned when MATLAB executes the command, <code>cmd</code>

## Comments

Characters	Description	Example
<code>(?#comment)</code>	Insert a comment in the regular expression. The comment text is ignored when matching the input string.	<code>'(?# Initial digit)\&lt;\d\w+'</code> includes a comment, and matches words that begin with a number.

## Search Flags

Search flags modify the behavior for matching expressions. An alternative to using a search flag within an expression is to pass an option input argument.

Flag	Description
<code>(?-i)</code>	Match letter case (default for <code>regexp</code> and <code>regexprep</code> ).
<code>(?i)</code>	Do not match letter case (default for <code>regexpi</code> ).

Flag	Description
(?s)	Match dot (.) in the pattern string with any character (default).
(?-s)	Match dot in the pattern with any character that is not a newline character.
(?-m)	Match the ^ and \$ metacharacters at the beginning and end of a string (default).
(?m)	Match the ^ and \$ metacharacters at the beginning and end of a line.
(?-x)	Include space characters and comments when matching (default).
(?x)	Ignore space characters and comments when matching. Use '\ ' and '\#' to match space and # characters.

The expression that the flag modifies can appear either after the parentheses, such as

`(?i)\w*`

or inside the parentheses and separated from the flag with a colon (:), such as

`(?i:\w*)`

The latter syntax allows you to change the behavior for part of a larger expression.

**Data Types**

char | cell

**outkey - Keyword that indicates which outputs to return**

'start' | 'end' | 'tokenExtents' | 'match' | 'tokens' | 'names' | 'split'

Keyword that indicates which outputs to return, specified as one of the following strings.

# regexp

---

Output Keyword	Returns
'start'	Starting indices of all matches, <code>startIndex</code>
'end'	Ending indices of all matches, <code>endIndex</code>
'tokenExtents'	Starting and ending indices of all tokens
'match'	Text of each substring that matches the pattern in <code>expression</code>
'tokens'	Text of each captured token in <code>str</code>
'names'	Name and text of each named token
'split'	Text of nonmatching substrings of <code>str</code>

## Data Types

char

## option - Search option

'once' | 'warnings' | 'ignorecase' | 'emptymatch' |  
'dotexceptnewline' | 'lineanchors' | ...

Search option, specified as a string. Options come in pairs: one option that corresponds to the default behavior, and one option that allows you to override the default. Specify only one option from a pair. Options can appear in any order.

Default	Override	Description
'all'	'once'	Match the expression as many times as possible (default), or only once.
'nowarnings'	'warnings'	Suppress warnings (default), or display them.
'matchcase'	'ignorecase'	Match letter case (default), or ignore case.
'noemptymatch'	'emptymatch'	Ignore zero length matches (default), or include them.

Default	Override	Description
'dotall'	'dotexceptnewline'	Match dot with any character (default), or all except newline (\n).
'stringanchors'	'lineanchors'	Apply ^ and \$ metacharacters to the beginning and end of a string (default), or to the beginning and end of a line.
'literalspacing'	'freespacing'	Include space characters and comments when matching (default), or ignore them. With freespacing, use '\ ' and '\#' to match space and # characters.

**Data Types**

char

**Output Arguments**

**startIndex - Starting index of each match**

row vector | cell array of row vectors

Starting indices of each match, returned as a row vector or cell array, as follows:

- If `str` and `expression` are both strings, the output is a row vector (or, if there are no matches, an empty array).
- If `str` or `expression` is a cell array of strings, the output is a cell array of row vectors. The output cell array has the same dimensions as the input cell array.
- If `str` and `expression` are both cell arrays, they must have the same dimensions. The output is a cell array with the same dimensions.

**endindex - Ending index of each match**

row vector | cell array of row vectors

Ending index of each match, returned as a row vector or cell array, as follows:

- If `str` and `expression` are both strings, the output is a row vector (or, if there are no matches, an empty array).

- If `str` or `expression` is a cell array of strings, the output is a cell array of row vectors. The output cell array has the same dimensions as the input cell array.
- If `str` and `expression` are both cell arrays, they must have the same dimensions. The output is a cell array with the same dimensions.

## **out** - Information about matches

numeric array | cell array | structure array

Information about matches, returned as a numeric, cell, or structure array. The information in the output depends upon the value you specify for `outkey`, as follows.

<b>Output Keyword</b>	<b>Output Description</b>	<b>Output Type and Dimensions</b>
'start'	Starting indices of matches	For both 'start' and 'end': <ul style="list-style-type: none"><li>• If <code>str</code> and <code>expression</code> are both strings, the output is a row vector (or, if there are no matches, an empty array).</li><li>• If <code>str</code> or <code>expression</code> is a cell array of strings, the output is a cell array of row vectors. The output cell array has the same dimensions as the input cell array.</li><li>• If <code>str</code> and <code>expression</code> are both cell arrays, they must have the same dimensions. The output is a cell array with the same dimensions.</li></ul>
'end'	Ending indices of matches	

Output Keyword	Output Description	Output Type and Dimensions
'tokenExtents'	Starting and ending indices of all tokens	<p>By default, when returning all matches:</p> <ul style="list-style-type: none"> <li>• If <code>str</code> and <code>expression</code> are both strings, the output is a 1-by-n-cell array, where n is the number of matches. Each cell contains an m-by-2 numeric array of indices, where m is the number of tokens in the match.</li> <li>• If <code>str</code> or <code>expression</code> is a cell array of strings, the output is a cell array with the same dimensions as the input cell array. Each cell contains a 1-by-n cell array, where each inner cell contains an m-by-2 numeric array.</li> <li>• If <code>str</code> and <code>expression</code> are both cell arrays, they must have the same dimensions. The output is a cell array with the same dimensions.</li> </ul> <p>When you specify the 'once' option to return only one match, the output is either an m-by-2 numeric array or a cell array with the same dimensions as <code>str</code> and/or <code>expression</code>.</p> <p>If a token is expected at a particular index N, but is not found, then MATLAB returns extents for that token of [N,N-1].</p>

# regex

Output Keyword	Output Description	Output Type and Dimensions
'match'	Text of each substring that matches the pattern in <code>expression</code>	<p>By default, when returning all matches:</p> <ul style="list-style-type: none"><li>• If <code>str</code> and <code>expression</code> are both strings, the output is a 1-by-<code>n</code>-cell array of strings, where <code>n</code> is the number of matches.</li><li>• If <code>str</code> or <code>expression</code> is a cell array of strings, the output is a cell array with the same dimensions as the input cell array. Each cell contains a 1-by-<code>n</code> cell array of strings.</li><li>• If <code>str</code> and <code>expression</code> are both cell arrays, they must have the same dimensions. The output is a cell array with the same dimensions.</li></ul> <p>When you specify the 'once' option to return only one match, the output is either a string or a cell array of strings with the same dimensions as <code>str</code> and <code>expression</code>.</p>
'tokens'	Text of each captured token in <code>str</code>	<p>By default, when returning all matches:</p> <ul style="list-style-type: none"><li>• If <code>str</code> and <code>expression</code> are both strings, the output is a 1-by-<code>n</code>-cell array, where <code>n</code> is the number of matches. Each cell contains a 1-by-<code>m</code> cell array of strings, where <code>m</code> is the number of tokens in the match.</li><li>• If <code>str</code> or <code>expression</code> is a cell array of strings, the output is a cell array with the same dimensions as the input cell array. Each cell contains a 1-by-<code>n</code> cell array, where each inner cell contains a 1-by-<code>m</code> cell array of strings.</li></ul>



Output Keyword	Output Description	Output Type and Dimensions
		<ul style="list-style-type: none"> <li>If <code>str</code> and <code>expression</code> are both cell arrays, they must have the same dimensions. The output is a cell array with the same dimensions.</li> </ul> <p>When you specify the 'once' option to return only one match, the output is a 1-by-m cell array of strings or a cell array that has the same dimensions as <code>str</code> and/or <code>expression</code>.</p> <p>If a token is expected at a particular index, but is not found, then MATLAB returns an empty string for the token, ''.</p>
'names'	Name and text of each named token	<p>For all matches:</p> <ul style="list-style-type: none"> <li>If <code>str</code> and <code>expression</code> are both strings, the output is a 1-by-n structure array, where n is the number of matches. The structure field names correspond to the token names.</li> <li>If <code>str</code> or <code>expression</code> is a cell array of strings, the output is a cell array with the same dimensions as the input cell array. Each cell contains a 1-by-n structure array.</li> <li>If <code>str</code> and <code>expression</code> are both cell arrays, they must have the same dimensions. The output is a cell array with the same dimensions.</li> </ul>
'split'	Text of nonmatching substrings of <code>str</code>	<p>For all matches:</p> <ul style="list-style-type: none"> <li>If <code>str</code> and <code>expression</code> are both strings, the output is a 1-by-n-cell array of strings, where n is the number of nonmatching strings.</li> </ul>

Output Keyword	Output Description	Output Type and Dimensions
		<ul style="list-style-type: none"><li>• If <code>str</code> or <code>expression</code> is a cell array of strings, the output is a cell array with the same dimensions as the input cell array. Each cell contains a 1-by-n cell array of strings.</li><li>• If <code>str</code> and <code>expression</code> are both cell arrays, they must have the same dimensions. The output is a cell array with the same dimensions.</li></ul>

## Examples

### Find Patterns in Single Strings

Find words that start with `c`, end with `t`, and contain one or more vowels between them.

```
str = 'bat cat can car coat court CUT ct CAT-scan';
expression = 'c[aeiou]+t';
startIndex = regexp(str,expression)
```

```
startIndex =
```

```
5 17
```

The regular expression `'c[aeiou]+t'` specifies this pattern:

- `c` must be the first character.
- `c` must be followed by one of the characters inside the brackets, `[aeiou]`.
- The bracketed pattern must occur one or more times, as indicated by the `+` operator.

- `t` must be the last character, with no characters between the bracketed pattern and the `t`.

Values in `startIndex` indicate the index of the first character of each word that matches the regular expression. The matching word `cat` starts at index 5, and `coat` starts at index 17. The words `CUT` and `CAT` do not match because they are uppercase.

### Find Patterns in Multiple Strings

Find the location of capital letters and spaces within strings in a cell array.

```
str = {'Madrid, Spain', 'Romeo and Juliet', 'MATLAB is great'};
capExpr = '[A-Z]';
spaceExpr = '\s';
```

```
capStartIndex = regexp(str, capExpr);
spaceStartIndex = regexp(str, spaceExpr);
```

`capStartIndex` and `spaceStartIndex` are cell arrays because the input `str` is a cell array.

View the indices for the capital letters.

```
celldisp(capStartIndex)
```

```
capStartIndex{1} =
```

```
1 9
```

```
capStartIndex{2} =
```

```
1 11
```

```
capStartIndex{3} =
 1 2 3 4 5 6
```

View the indices for the spaces.

```
celldisp(spaceStartIndex)
```

```
spaceStartIndex{1} =
 8
```

```
spaceStartIndex{2} =
 6 10
```

```
spaceStartIndex{3} =
 7 10
```

## **Return Substrings Using match Keyword**

Capture words within a string that contain the letter x.

```
str = 'EXTRA! The regexp function helps you relax.';
expression = '\w*x\w*';
matchStr = regexp(str,expression,'match')
```

```
matchStr =
 'regexp' 'relax'
```

The regular expression '`\w*x\w*`' specifies that the string:

- Begins with any number of alphanumeric or underscore characters, `\w*`.
- Contains the lowercase letter `x`.
- Ends with any number of alphanumeric or underscore characters after the `x`, including none, as indicated by `\w*`.

### Split String at Delimiter Using `split` Keyword

Split a string into several substrings, where each substring is delimited by a `^` character.

```
str = ['Split ^this string into ^several pieces'];
expression = '\^';
splitStr = regexp(str,expression,'split')
```

```
splitStr =
 'Split ' 'this string into ' 'several pieces'
```

Because the carat symbol has special meaning in regular expressions, precede it with the escape character, a backslash (`\`). To split a string at other delimiters, such as a semicolon, you do not need to include the backslash.

## Return Both Matching and Nonmatching Substrings

Capture parts of a string that match a regular expression using the 'match' keyword, and the remaining parts that do not match using the 'split' keyword.

```
str = 'She sells sea shells by the seashore.';
expression = '[Ss]h.';
[match,noMatch] = regexp(str,expression,'match','split')
```

```
match =
```

```
 'She' 'she' 'sho'
```

```
noMatch =
```

```
 '' ' sells sea ' 'lls by the sea' 're.'
```

The regular expression '[Ss]h.' specifies that:

- S or s is the first character.
- h is the second character.
- The third character can be anything, including a space, as indicated by the dot (.).

When the first (or last) character in a string matches a regular expression, the first (or last) return value from the 'split' keyword is an empty string.

Optionally, reassemble the original string from the substrings.

```
combinedStr = strjoin(noMatch,match)
```

```
combinedStr =
```

She sells sea shells by the seashore.

### Capture Substrings of Matches Using Ordinal Tokens

Find the names of HTML tags by defining a token within a regular expression. Tokens are indicated with parentheses, ().

```
str = '<title>My Title</title><p>Here is some text.</p>';
expression = '<(\w+).*>.*</\1>';
[tokens,matches] = regexp(str,expression,'tokens','match');
```

The regular expression `<(\w+).*>.*</\1>` specifies this pattern:

- `<(\w+)` finds an opening angle bracket followed by one or more alphanumeric or underscore characters. Enclosing `\w+` in parentheses captures the name of the HTML tag in a token.
- `.*>` finds any number of additional characters, such as HTML attributes, and a closing angle bracket.
- `</\1>` finds the end tag corresponding to the first token (indicated by `\1`). The end tag has the form `<tagname>`.

View the tokens and matching substrings.

```
celldisp(tokens)
```

```
tokens{1}{1} =
 title
```

```
tokens{2}{1} =
 p
```

```
celldisp(matches)
```

```
matches{1} =
 <title>My Title</title>
```

```
matches{2} =
 <p>Here is some text.</p>
```

## Capture Substrings of Matches Using Named Tokens

Parse dates that can appear with either the day or the month first, in these forms: mm/dd/yyyy or dd-mm-yyyy. Use named tokens to identify each part of the date.

```
str = '01/11/2000 20-02-2020 03/30/2000 16-04-2020';
expression = ['(?<month>\d+)/(?<day>\d+)/(?<year>\d+)' | ...
 '(?<day>\d+) - (?<month>\d+) - (?<year>\d+)'];
tokenNames = regexp(str,expression,'names');
```

The regular expression specifies this pattern:

- `(?<name>\d+)` finds one or more numeric digits and assigns the result to the token indicated by name.
- `|` is the logical or operator, which indicates that there are two possible patterns for dates. In the first pattern, slashes (/) separate the tokens. In the second pattern, hyphens (-) separate the tokens.

View the named tokens.

```
for k = 1:length(tokenNames)
 disp(tokenNames(k))
end
```

```
month: '01'
day: '11'
year: '2000'
```

```
month: '02'
day: '20'
year: '2020'
```

```
month: '03'
day: '30'
year: '2000'
```



```
month: '04'
 day: '16'
 year: '2020'
```

### Perform Case-Insensitive Matches

Find both uppercase and lowercase instances of a word.

By default, `regexp` performs case-sensitive matching.

```
str = 'A string with UPPERCASE and lowercase text.';
expression = '\w*case';
matchStr = regexp(str,expression,'match')
```

```
matchStr =

 'lowercase'
```

The regular expression specifies that the string:

- Begins with any number of alphanumeric or underscore characters, `\w*`.
- Ends with the literal text `case`.

The `regexpi` function uses the same syntax as `regexp`, but performs case-insensitive matching.

```
matchWithRegexpi = regexpi(str,expression,'match')
```

```
matchWithRegexpi =

 'UPPERCASE' 'lowercase'
```

# regexp

---

Alternatively, disable case-sensitive matching for regexp using the 'ignorecase' option.

```
matchWithIgnorecase = regexp(str,expression,'match','ignorecase')
```

```
matchWithIgnorecase =
 'UPPERCASE' 'lowercase'
```

For multiple expressions, disable case-sensitive matching for selected expressions using the (?i) search flag.

```
expression = {'(?-i)\w*case';...
 '(?i)\w*case'};
matchStr = regexp(str,expression,'match');
celldisp(matchStr)
```

```
matchStr{1}{1} =
```

```
lowercase
```

```
matchStr{2}{1} =
```

```
UPPERCASE
```

```
matchStr{2}{2} =
```

```
lowercase
```

## Parse Strings with Newline Characters

Create a string that contains a newline, \n, and parse the string using a regular expression.

```
str = sprintf('abc\n de');
expression = '.*';
matchStr = regexp(str,expression,'match')
```

```
matchStr =
 [1x7 char]
```

By default, the dot (.) matches every character, including the newline, and returns a single match that is equivalent to the original string.

Exclude newline characters from the match using the 'dotexceptnewline' option. This returns separate matches for each line of text.

```
matchStrNoNewline = regexp(str,expression,'match','dotexceptnewline')
```

```
matchStrNoNewline =
 'abc' ' de'
```

Find the first or last character of each line using the ^ or \$ metacharacters and the 'lineanchors' option.

```
expression = '.$';
lastInLine = regexp(str,expression,'match','lineanchors')
```

```
lastInLine =
```

```
'c' 'e'
```

## Definitions

### Tokens

Tokens are portions of the matched text that correspond to portions of the regular expression. To create tokens, enclose part of the regular expression in parentheses.

For example, this expression finds a date of the form dd-mmm-yyyy, including tokens for the day, month, and year.

```
str = 'Here is a date: 01-Apr-2020';
expression = '(\d+)-(\w+)-(\d+)';

mydate = regexp(str,expression,'tokens');
mydate{:}

ans =
 '01' 'April' '2020'
```

You can associate names with tokens so that they are more easily identifiable:

```
str = 'Here is a date: 01-Apr-2020';
expression = '(?<day>\d+)-(?<month>\w+)-(?<year>\d+)';

mydate = regexp(str,expression,'names')

mydate =
 day: '01'
 month: 'Apr'
 year: '2020'
```

For more information, see “Tokens in Regular Expressions”.

## Algorithms

MATLAB parses each input string from left to right, attempting to match the text in the string with the first element of the regular

expression. During this process, MATLAB skips over any text that does not match.

When MATLAB finds the first match, it continues parsing the string to match the second piece of the expression, and so on.

**Tips**

- Use `strfind` to find an exact character match within a string. Use `regex` to look for a pattern of characters.

**See Also**

`regexp` | `regprep` | `regxprtranslate` | `strfind` | `strjoin` | `strsplit` | `strep`

**Concepts**

- “Regular Expressions”
- “Lookahead Assertions in Regular Expressions”
- “Dynamic Regular Expressions”

# regexpi

---

**Purpose** Match regular expression (case insensitive)

**Syntax** `startIndex = regexpi(str,expression)`  
`[startIndex,endIndex] = regexpi(str,expression)`

`out = regexpi(str,expression,outkey)`  
`[out1,...,outN] =`  
`regexpi(str,expression,outkey1,...,outkeyN)`

`___ = regexpi( ___,option1,...,optionM)`

**Description** `startIndex = regexpi(str,expression)` returns the starting index of each substring of `str` that matches the character patterns specified by the regular expression, without regard to letter case. If there are no matches, `startIndex` is an empty array.

`[startIndex,endIndex] = regexpi(str,expression)` returns the starting and ending indices of all matches.

`out = regexpi(str,expression,outkey)` returns the output specified by `outkey`. For example, if `outkey` is 'match', then `regexpi` returns the substrings that match the expression rather than their starting indices.

`[out1,...,outN] =`  
`regexpi(str,expression,outkey1,...,outkeyN)` returns the outputs specified by multiple output keywords, in the specified order. For example, if you specify 'match','tokens', then `regexpi` returns substrings that match the entire expression and tokens that match parts of the expression.

`___ = regexpi( ___,option1,...,optionM)` modifies the search using the specified option flags. For example, specify 'matchcase' to perform a case-sensitive match. You can include any of the inputs and request any of the outputs from previous syntaxes.

## Input Arguments

### str - Input text

string | cell array of strings

Input text, specified as a string or a cell array of strings. Each string can be of any length and contain any characters.

If `str` and `expression` are both cell arrays, they must have the same dimensions.

### Data Types

char | cell

### expression - Regular expression

string | cell array of strings

Regular expression, specified as a string or a cell array of strings. Each expression can contain characters, metacharacters, operators, tokens, and flags that specify patterns to match in `str`.

The following tables describe the elements of regular expressions.

### Metacharacters

Metacharacters represent letters, letter ranges, digits, and space characters. Use them to construct a generalized pattern of characters.

Metacharacter	Description	Example
.	Any single character, including white space	'..ain' matches sequences of five consecutive characters that end with 'ain'.
[c <sub>1</sub> c <sub>2</sub> c <sub>3</sub> ]	Any character contained within the brackets. The following characters are treated literally: \$   . * + ? and - when not used to indicate a range.	'[rp.]ain' matches 'rain' or 'pain' or '.ain'.

# regexpi

Metacharacter	Description	Example
<code>[^c<sub>1</sub>c<sub>2</sub>c<sub>3</sub>]</code>	Any character not contained within the brackets. The following characters are treated literally: <code>\$   . * + ?</code> and <code>-</code> when not used to indicate a range.	' <code>[^*rp]ain</code> ' matches all four-letter sequences that end in 'ain', except 'rain' and 'pain' and <code>`*ain</code> '. For example, it matches 'gain', 'lain', or 'vain'.
<code>[c<sub>1</sub>-c<sub>2</sub>]</code>	Any character in the range of c <sub>1</sub> through c <sub>2</sub>	' <code>[A-G]</code> ' matches a single character in the range of A through G.
<code>\w</code>	Any alphabetic, numeric, or underscore character. For English character sets, <code>\w</code> is equivalent to <code>[a-zA-Z_0-9]</code>	' <code>\w*</code> ' identifies a word.
<code>\W</code>	Any character that is not alphabetic, numeric, or underscore. For English character sets, <code>\W</code> is equivalent to <code>[^a-zA-Z_0-9]</code>	' <code>\W*</code> ' identifies a substring that is not a word.
<code>\s</code>	Any white-space character; equivalent to <code>[\f\n\r\t\v]</code>	' <code>\w*n\s</code> ' matches words that end with the letter n, followed by a white-space character.
<code>\S</code>	Any non-white-space character; equivalent to <code>[^\f\n\r\t\v]</code>	' <code>\d\S</code> ' matches a numeric digit followed by any non-white-space character.
<code>\d</code>	Any numeric digit; equivalent to <code>[0-9]</code>	' <code>\d*</code> ' matches any number of consecutive digits.
<code>\D</code>	Any nondigit character; equivalent to <code>[^0-9]</code>	' <code>\w*\D&gt;</code> ' matches words that do not end with a numeric digit.



Metacharacter	Description	Example
\oN or \o{N}	Character of octal value N	'\o{40}' matches the space character, defined by octal 40.
\xN or \x{N}	Character of hexadecimal value N	'\x2C' matches the comma character, defined by hex 2C.

### Character Representation

Operator	Description
\a	Alarm (beep)
\b	Backspace
\f	Form feed
\n	New line
\r	Carriage return
\t	Horizontal tab
\v	Vertical tab
\char	Any character with special meaning in regular expressions that you want to match literally (for example, use \\ to match a single backslash)

### Quantifiers

Quantifiers specify the number of times a string pattern must occur in the matching string.

Quantifier	Matches the expression when it occurs...	Example
expr*	0 or more times consecutively.	'\w*' matches a word of any length.
expr?	0 times or 1 time.	'\w*(\.\m)?' matches words that optionally end with the extension .m.

# regexpi

Quantifier	Matches the expression when it occurs...	Example
<code>expr+</code>	1 or more times consecutively.	'' matches an <img> HTML tag when the file name contains one or more characters.
<code>expr{m,n}</code>	At least m times, but no more than n times consecutively. {0,1} is equivalent to ?.	'\S{4,8}' matches between four and eight non-white-space characters.
<code>expr{m,}</code>	At least m times consecutively. {0,} and {1,} are equivalent to * and +, respectively.	'<a href="\w{1,}\.html">' matches an <a> HTML tag when the file name contains one or more characters.
<code>expr{n}</code>	Exactly n times consecutively. Equivalent to {n,n}.	'\d{4}' matches four consecutive digits.

Quantifiers can appear in three modes, described in the following table. *q* represents any of the quantifiers in the previous table.

Mode	Description	Example
<code>exprq</code>	Greedy expression: match as many characters as possible.	Given the string '<tr><td><p>text</p></td>', the expression '</?t.*>' matches all characters between <tr and /td>:  '<tr><td><p>text</p></td>'
<code>exprq?</code>	Lazy expression: match as few characters as necessary.	Given the string '<tr><td><p>text</p></td>', the expression '</?t.*?>' ends each match at the first occurrence of the closing bracket (>):

Mode	Description	Example
		'<tr>'   '<td>'   '</td>'
exprq+	Possessive expression: match as much as possible, but do not rescan any portions of the string.	Given the string '<tr><td><p>text</p></td>', the expression '</?t.*+>' does not return any matches, because the closing bracket is captured using .*, and is not rescanned.

### Grouping Operators

Grouping operators allow you to capture tokens, apply one operator to multiple elements, or disable backtracking in a specific group.

Grouping Operator	Description	Example
(expr)	Group elements of the expression and capture tokens.	'Joh?n\s(\w*)' captures a token that contains the last name of any person with the first name John or Jon.
(?:expr)	Group, but do not capture tokens.	'(?:[aeiou][^aeiou]){2}' matches two consecutive patterns of a vowel followed by a nonvowel, such as 'anon'.  Without grouping, '[aeiou][^aeiou]{2}' matches a vowel followed by two nonvowels.

# regexpi

Grouping Operator	Description	Example
(?>expr)	Group atomically. Do not backtrack within the group to complete the match, and do not capture tokens.	'A(?>.* )Z' does not match 'AtoZ', although 'A(?:.* )Z' does. Using the atomic group, Z is captured using .* and is not rescanned.
(expr1 expr2)	Match expression expr1 or expression expr2.  If there is a match with expr1, then expr2 is ignored.  You can include ?: or ?> after the opening parenthesis to suppress tokens or group atomically.	'(let tel)\w+' matches words in a string that start with let or tel.

## Anchors

Anchors in the expression match the beginning or end of the string or word.

Anchor	Matches the...	Example
^expr	Beginning of the input string.	'^M\w*' matches a word starting with M at the beginning of the string.
expr\$	End of the input string.	'\w*m\$' matches words ending with m at the end of the string.
\<expr	Beginning of a word.	'\<n\w*' matches any words starting with n.
expr\>	End of a word.	'\w*e\>' matches any words ending with e.

## Lookaround Assertions

Lookaround assertions look for string patterns that immediately precede or follow the intended match, but are not part of the match.

The pointer remains at the current location, and characters that correspond to the `test` expression are not captured or discarded. Therefore, lookahead assertions can match overlapping character groups.

Lookaround Assertion	Description	Example
<code>expr(?=test)</code>	Look ahead for characters that match <code>test</code> .	<code>'\w*(?=ing)'</code> matches strings that are followed by <code>ing</code> , such as <code>'Fly'</code> and <code>'fall'</code> in the input string <code>'Flying, not falling.'</code>
<code>expr(?!test)</code>	Look ahead for characters that do not match <code>test</code> .	<code>'i(?!ng)'</code> matches instances of the letter <code>i</code> that are not followed by <code>ng</code> .
<code>(?&lt;=test)expr</code>	Look behind for characters that match <code>test</code> .	<code>'(?&lt;=re)\w*'</code> matches strings that follow <code>'re'</code> , such as <code>'new'</code> , <code>'use'</code> , and <code>'cycle'</code> in the input string <code>'renew, reuse, recycle'</code>
<code>(?&lt;!test)expr</code>	Look behind for characters that do not match <code>test</code> .	<code>'(?&lt;!\d)(\d)(?!\d)'</code> matches single-digit numbers (digits that do not precede or follow other digits).

If you specify a lookahead assertion *before* an expression, the operation is equivalent to a logical AND.

Operation	Description	Example
<code>(?=test)expr</code>	Match both <code>test</code> and <code>expr</code> .	<code>'(?=[a-z])[^aeiou]'</code> matches consonants.
<code>(?!test)expr</code>	Match <code>expr</code> and do not match <code>test</code> .	<code>'(?![aeiou])[a-z]'</code> matches consonants.

### Logical and Conditional Operators

Logical and conditional operators allow you to test the state of a given condition, and then use the outcome to determine which string, if any,

# regexp

to match next. These operators support logical OR, and if or if/else conditions.

Conditions can be tokens, lookaround operators, or dynamic expressions of the form `(?@cmd)`. Dynamic expressions must return a logical or numeric value.

Conditional Operator	Description	Example
<code>expr1 expr2</code>	Match expression <code>expr1</code> or expression <code>expr2</code> . If there is a match with <code>expr1</code> , then <code>expr2</code> is ignored.	<code>'(let tel)\w+'</code> matches words in a string that start with <code>let</code> or <code>tel</code> .
<code>(?(cond)expr)</code>	If condition <code>cond</code> is true, then match <code>expr</code> .	<code>'(?:[A-Z]:\\)'</code> matches a drive name, such as <code>C:\</code> , when run on a Windows system.
<code>(?(cond)expr1 expr2)</code>	If condition <code>cond</code> is true, then match <code>expr1</code> . Otherwise, match <code>expr2</code> .	<code>'Mr(s?)\.*(?:her his)\w*'</code> matches strings that include <code>her</code> when the string begins with <code>Mrs</code> , or that include <code>his</code> when the string begins with <code>Mr</code> .

## Token Operators

Tokens are portions of the matched text that you define by enclosing part of the regular expression in parentheses. You can refer to a token by its sequence in the string (an ordinal token), or assign names to tokens for easier code maintenance and readable output.

Ordinal Token Operator	Description	Example
(expr)	Capture in a token the characters that match the enclosed expression.	'Joh?n\s(\w*)' captures a token that contains the last name of any person with the first name John or Jon.
\N	Match the Nth token.	'<(\w+).*>.*</\1>' captures tokens for HTML tags, such as 'title' from the string '<title>Some text</title>'.
(?(N)expr1 expr2)	If the Nth token is found, then match expr1. Otherwise, match expr2.	'Mr(s?)\..*?(?(1)her his)\w*' matches strings that include her when the string begins with Mrs, or that include his when the string begins with Mr.

Named Token Operator	Description	Example
(?<name>expr)	Capture in a named token the characters that match the enclosed expression.	'(?<month>\d+)-(?<day>\d+)-(?<yr>\d+)' creates named tokens for the month, day, and year in an input date string of the form mm-dd-yy.
\k<name>	Match the token referred to by name.	'<(?(tag)\w+).*>.*</\k<tag>>'' captures tokens for HTML tags, such as 'title' from the string '<title>Some text</title>'.
(?(name)expr1 expr2)	If the named token is found, then match expr1. Otherwise, match expr2.	'Mr(?(sex>s?)\..*?(?(sex)her his)\w*' matches strings that include her when the string begins with Mrs, or that include his when the string begins with Mr.

---

**Note** If an expression has nested parentheses, MATLAB captures tokens that correspond to the outermost set of parentheses. For example, given the search pattern '(and(y|rew))', MATLAB creates a token for 'andrew' but not for 'y' or 'rew'.

---

## Dynamic Regular Expressions

Dynamic expressions allow you to execute a MATLAB command or a regular expression to determine the text to match.

The parentheses that enclose dynamic expressions do *not* create a capturing group.

Operator	Description	Example
(??expr)	Parse expr and include the resulting string in the match expression.  When parsed, expr must correspond to a complete, valid regular expression. Dynamic expressions that use the backslash escape character (\) require two backslashes: one for the initial parsing of expr, and one for the complete match.	'^(\d+)((?!\w{\$1}))' determines how many characters to match by reading a digit at the beginning of the string. The dynamic expression is enclosed in a second set of parentheses so that the resulting match is captured in a token. For instance, matching '5XXXXX' captures tokens for '5' and 'XXXXX'.
(??@cmd)	Execute the MATLAB command represented by cmd, and include the string returned by the command in the match expression.	'(.{2,}).?(?@flip1r(\$1))' finds palindromes that are at least four characters long, such as 'abba'.
(?@cmd)	Execute the MATLAB command represented by cmd, but discard any output the command returns. (Helpful for diagnosing regular expressions.)	'\w*?(?@disp(\$1))\1\w*' matches words that include double letters (such as pp), and displays intermediate results.



Within dynamic expressions, use the following operators to define replacement strings.

Replacement String Operator	Description
\$& or \$0	Portion of the input string that is currently a match
\$`	Portion of the input string that precedes the current match
\$'	Portion of the input string that follows the current match (use \$' ' to represent the string \$')
\$N	Nth token
\$<name>	Named token
\${cmd}	String returned when MATLAB executes the command, cmd

### Comments

Characters	Description	Example
(?#comment)	Insert a comment in the regular expression. The comment text is ignored when matching the input string.	'(?# Initial digit)\<d\w+' includes a comment, and matches words that begin with a number.

### Search Flags

Search flags modify the behavior for matching expressions. An alternative to using a search flag within an expression is to pass an option input argument.

Flag	Description
(?-i)	Match letter case (default for regexp and regexprep).
(?i)	Do not match letter case (default for regexpi).

# regexpi

---

Flag	Description
(?s)	Match dot (.) in the pattern string with any character (default).
(?-s)	Match dot in the pattern with any character that is not a newline character.
(?-m)	Match the ^ and \$ metacharacters at the beginning and end of a string (default).
(?m)	Match the ^ and \$ metacharacters at the beginning and end of a line.
(?-x)	Include space characters and comments when matching (default).
(?x)	Ignore space characters and comments when matching. Use '\ ' and '\#' to match space and # characters.

The expression that the flag modifies can appear either after the parentheses, such as

```
(?i)\w*
```

or inside the parentheses and separated from the flag with a colon (:), such as

```
(?i:\w*)
```

The latter syntax allows you to change the behavior for part of a larger expression.

## Data Types

char | cell

## outkey - Keyword that indicates which outputs to return

```
'start' | 'end' | 'tokenExtents' | 'match' | 'tokens' | 'names'
| 'split'
```

Keyword that indicates which outputs to return, specified as one of the following strings.

Output Keyword	Returns
'start'	Starting indices of all matches, <code>startIndex</code>
'end'	Ending indices of all matches, <code>endIndex</code>
'tokenExtents'	Starting and ending indices of all tokens
'match'	Text of each substring that matches the pattern in <code>expression</code>
'tokens'	Text of each captured token in <code>str</code>
'names'	Name and text of each named token
'split'	Text of nonmatching substrings of <code>str</code>

**Data Types**

char

**option - Search option**

'once' | 'warnings' | 'matchcase' | 'emptymatch' | 'dotexceptnewline' | 'lineanchors' | ...

Search option, specified as a string. Options come in pairs: one option that corresponds to the default behavior, and one option that allows you to override the default. Specify only one option from a pair. Options can appear in any order.

Default	Override	Description
'all'	'once'	Match the expression as many times as possible (default), or only once.
'nowarnings'	'warnings'	Suppress warnings (default), or display them.
'ignorecase'	'matchcase'	Ignore letter case (default), or match case.
'noemptymatch'	'emptymatch'	Ignore zero length matches (default), or include them.

# regexpi

Default	Override	Description
'dotall'	'dotexceptnewline'	Match dot with any character (default), or all except newline (\n).
'stringanchors'	'lineanchors'	Apply ^ and \$ metacharacters to the beginning and end of a string (default), or to the beginning and end of a line.
'literalspacing'	'freespacing'	Include space characters and comments when matching (default), or ignore them. With freespacing, use '\ ' and '\#' to match space and # characters.

## Data Types

char

## Output Arguments

### **startIndex** - Starting index of each match

row vector | cell array of row vectors

Starting indices of each match, returned as a row vector or cell array, as follows:

- If `str` and `expression` are both strings, the output is a row vector (or, if there are no matches, an empty array).
- If `str` or `expression` is a cell array of strings, the output is a cell array of row vectors. The output cell array has the same dimensions as the input cell array.
- If `str` and `expression` are both cell arrays, they must have the same dimensions. The output is a cell array with the same dimensions.

### **endIndex** - Ending index of each match

row vector | cell array of row vectors

Ending index of each match, returned as a row vector or cell array, as follows:

- If `str` and `expression` are both strings, the output is a row vector (or, if there are no matches, an empty array).

- If `str` or `expression` is a cell array of strings, the output is a cell array of row vectors. The output cell array has the same dimensions as the input cell array.
- If `str` and `expression` are both cell arrays, they must have the same dimensions. The output is a cell array with the same dimensions.

**out - Information about matches**

numeric array | cell array | structure array

Information about matches, returned as a numeric, cell, or structure array. The information in the output depends upon the value you specify for `outkey`, as follows.

Output Keyword	Output Description	Output Type and Dimensions
'start'	Starting indices of matches	For both 'start' and 'end': <ul style="list-style-type: none"> <li>• If <code>str</code> and <code>expression</code> are both strings, the output is a row vector (or, if there are no matches, an empty array).</li> <li>• If <code>str</code> or <code>expression</code> is a cell array of strings, the output is a cell array of row vectors. The output cell array has the same dimensions as the input cell array.</li> <li>• If <code>str</code> and <code>expression</code> are both cell arrays, they must have the same dimensions. The output is a cell array with the same dimensions.</li> </ul>
'end'	Ending indices of matches	

# regexpi

Output Keyword	Output Description	Output Type and Dimensions
'tokenExtents'	Starting and ending indices of all tokens	<p>By default, when returning all matches:</p> <ul style="list-style-type: none"><li>• If <code>str</code> and <code>expression</code> are both strings, the output is a 1-by-n-cell array, where <code>n</code> is the number of matches. Each cell contains an m-by-2 numeric array of indices, where <code>m</code> is the number of tokens in the match.</li><li>• If <code>str</code> or <code>expression</code> is a cell array of strings, the output is a cell array with the same dimensions as the input cell array. Each cell contains a 1-by-n cell array, where each inner cell contains an m-by-2 numeric array.</li><li>• If <code>str</code> and <code>expression</code> are both cell arrays, they must have the same dimensions. The output is a cell array with the same dimensions.</li></ul> <p>When you specify the 'once' option to return only one match, the output is either an m-by-2 numeric array or a cell array with the same dimensions as <code>str</code> and/or <code>expression</code>.</p> <p>If a token is expected at a particular index <code>N</code>, but is not found, then MATLAB returns extents for that token of <code>[N,N-1]</code>.</p>

Output Keyword	Output Description	Output Type and Dimensions
'match'	Text of each substring that matches the pattern in <code>expression</code>	<p>By default, when returning all matches:</p> <ul style="list-style-type: none"> <li>• If <code>str</code> and <code>expression</code> are both strings, the output is a 1-by-<code>n</code>-cell array of strings, where <code>n</code> is the number of matches.</li> <li>• If <code>str</code> or <code>expression</code> is a cell array of strings, the output is a cell array with the same dimensions as the input cell array. Each cell contains a 1-by-<code>n</code> cell array of strings.</li> <li>• If <code>str</code> and <code>expression</code> are both cell arrays, they must have the same dimensions. The output is a cell array with the same dimensions.</li> </ul> <p>When you specify the 'once' option to return only one match, the output is either a string or a cell array of strings with the same dimensions as <code>str</code> and <code>expression</code>.</p>
'tokens'	Text of each captured token in <code>str</code>	<p>By default, when returning all matches:</p> <ul style="list-style-type: none"> <li>• If <code>str</code> and <code>expression</code> are both strings, the output is a 1-by-<code>n</code>-cell array, where <code>n</code> is the number of matches. Each cell contains a 1-by-<code>m</code> cell array of strings, where <code>m</code> is the number of tokens in the match.</li> <li>• If <code>str</code> or <code>expression</code> is a cell array of strings, the output is a cell array with the same dimensions as the input cell array. Each cell contains a 1-by-<code>n</code> cell array, where each inner cell contains a 1-by-<code>m</code> cell array of strings.</li> </ul>

# regexpi

Output Keyword	Output Description	Output Type and Dimensions
		<ul style="list-style-type: none"><li>• If <code>str</code> and <code>expression</code> are both cell arrays, they must have the same dimensions. The output is a cell array with the same dimensions.</li></ul> <p>When you specify the 'once' option to return only one match, the output is a 1-by-m cell array of strings or a cell array that has the same dimensions as <code>str</code> and/or <code>expression</code>.</p> <p>If a token is expected at a particular index, but is not found, then MATLAB returns an empty string for the token, ''.</p>
'names'	Name and text of each named token	<p>For all matches:</p> <ul style="list-style-type: none"><li>• If <code>str</code> and <code>expression</code> are both strings, the output is a 1-by-n structure array, where n is the number of matches. The structure field names correspond to the token names.</li><li>• If <code>str</code> or <code>expression</code> is a cell array of strings, the output is a cell array with the same dimensions as the input cell array. Each cell contains a 1-by-n structure array.</li><li>• If <code>str</code> and <code>expression</code> are both cell arrays, they must have the same dimensions. The output is a cell array with the same dimensions.</li></ul>
'split'	Text of nonmatching substrings of <code>str</code>	<p>For all matches:</p> <ul style="list-style-type: none"><li>• If <code>str</code> and <code>expression</code> are both strings, the output is a 1-by-n-cell array of strings, where n is the number of nonmatching strings.</li></ul>



Output Keyword	Output Description	Output Type and Dimensions
		<ul style="list-style-type: none"> <li>• If <code>str</code> or <code>expression</code> is a cell array of strings, the output is a cell array with the same dimensions as the input cell array. Each cell contains a 1-by-n cell array of strings.</li> <li>• If <code>str</code> and <code>expression</code> are both cell arrays, they must have the same dimensions. The output is a cell array with the same dimensions.</li> </ul>

## Examples

### Pattern Matching

Find words that start with `c`, end with `t`, and contain one or more vowels between them.

```
str = 'bat cat can car COAT court cut ct CAT-scan';
expression = 'c[aeiou]+t';
startIndex = regexpi(str,expression)
```

```
startIndex =
 5 17 28 35
```

Values in `startIndex` indicate the index of the first character of each word that matches the regular expression.

The regular expression `'c[aeiou]+t'` specifies this pattern:

- `c` must be the first character.
- `c` must be followed by one of the characters inside the brackets, `[aeiou]`.
- The bracketed pattern must occur one or more times, as indicated by the `+` operator.

- `t` must be the last character, with no characters between the bracketed pattern and the `t`.

## Case-Sensitive Match

Match letter case in all or part of an expression.

By default, `regexpi` performs case-insensitive matching.

```
str = 'A string with UPPERCASE and lowercase text.';
expression = '\w*case';
matchStr = regexpi(str,expression,'match')
```

```
matchStr =
 'UPPERCASE' 'lowercase'
```

Use the `regexp` function with the same syntax as `regexpi` to perform case-sensitive matching.

```
matchWithRegexp = regexp(str,expression,'match')
```

```
matchWithRegexp =
 'lowercase'
```

To disable case-sensitive matching for `regexp`, use the `'ignorecase'` option.

```
matchWithIgnorecase = regexp(str,expression,'match','ignorecase')
```

```
matchWithIgnorecase =
 'UPPERCASE' 'lowercase'
```

For multiple expressions, enable and disable case-insensitive matching for selected expressions using the `(?i)` and `(?-i)` search flags.

```
expression = {'(?-i)\w*case';...
 '(?i)\w*case'};
matchStr = regexp(str,expression,'match');
celldisp(matchStr)
```

```
matchStr{1}{1} =
 lowercase
```

```
matchStr{2}{1} =
 UPPERCASE
```

```
matchStr{2}{2} =
 lowercase
```

## Definitions

### Tokens

Tokens are portions of the matched text that correspond to portions of the regular expression. To create tokens, enclose part of the regular expression in parentheses.

For example, this expression finds a date of the form dd-mmm-yyyy, including tokens for the day, month, and year.

```
str = 'Here is a date: 01-Apr-2020';
expression = '(\d+)-(\w+)-(\d+)';
```

```
mydate = regexp(str,expression,'tokens');
mydate{:}
```

```
ans =
 '01' 'April' '2020'
```

You can associate names with tokens so that they are more easily identifiable:

```
str = 'Here is a date: 01-Apr-2020';
expression = '(?<day>\d+)-(?<month>\w+)-(?<year>\d+)';
```

```
mydate = regexp(str,expression,'names')
```

```
mydate =
 day: '01'
 month: 'Apr'
 year: '2020'
```

# regexpi

---

For more information, see “Tokens in Regular Expressions”.

## **See Also**

`regex` | `regexprep` | `regextranslate` | `strfind` | `strjoin` | `strsplit` | `strep`

## **Concepts**

- “Lookahead Assertions in Regular Expressions”
- “Dynamic Regular Expressions”

## Purpose

Replace string using regular expression

## Syntax

```
newStr = regexprep(str,expression,replace)
newStr =
regexprep(str,expression,replace,option1,...optionM)
```

## Description

`newStr = regexprep(str,expression,replace)` replaces the text in `str` that matches `expression` with the text described by `replace`. The `regexprep` function returns the updated text in `newStr`.

- If `str` is a string, then `newStr` is also a string, even when `expression` or `replace` is a cell array of strings. When `expression` is a cell array, `regexprep` applies the first expression to the string, and then applies each subsequent expression to the preceding result.
- If `str` is a cell array, then `newStr` is a cell array with the same dimensions as `str`. For each element of `str`, the `regexprep` function applies each expression in sequence.
- If there are no matches to `expression`, then `newStr` is equivalent to `str`.

`newStr = regexprep(str,expression,replace,option1,...optionM)` modifies the search using the specified options. For example, specify `'ignorecase'` to perform a case-insensitive match.

## Input Arguments

### **str - Text to update**

string | cell array of strings

Text to update, specified as a string or a cell array of strings.

### **Data Types**

char | cell

### **expression - Regular expression**

string | cell array of strings

Regular expression, specified as a string or a cell array of strings. Each expression can contain characters, metacharacters, operators, tokens, and flags that specify patterns to match in `str`.

The following tables describe the elements of regular expressions.

## Metacharacters

Metacharacters represent letters, letter ranges, digits, and space characters. Use them to construct a generalized pattern of characters.

Metacharacter	Description	Example
<code>.</code>	Any single character, including white space	' <code>..ain</code> ' matches sequences of five consecutive characters that end with ' <code>ain</code> '.
<code>[c<sub>1</sub>c<sub>2</sub>c<sub>3</sub>]</code>	Any character contained within the brackets. The following characters are treated literally: <code>\$   . * + ?</code> and <code>-</code> when not used to indicate a range.	' <code>[rp.]ain</code> ' matches ' <code>rain</code> ' or ' <code>pain</code> ' or ' <code>.ain</code> '.
<code>[^c<sub>1</sub>c<sub>2</sub>c<sub>3</sub>]</code>	Any character not contained within the brackets. The following characters are treated literally: <code>\$   . * + ?</code> and <code>-</code> when not used to indicate a range.	' <code>[^*rp]ain</code> ' matches all four-letter sequences that end in ' <code>ain</code> ', except ' <code>rain</code> ' and ' <code>pain</code> ' and ' <code>*ain</code> '. For example, it matches ' <code>gain</code> ', ' <code>lain</code> ', or ' <code>vain</code> '.
<code>[c<sub>1</sub>-c<sub>2</sub>]</code>	Any character in the range of <code>c<sub>1</sub></code> through <code>c<sub>2</sub></code>	' <code>[A-G]</code> ' matches a single character in the range of A through G.
<code>\w</code>	Any alphabetic, numeric, or underscore character. For English character sets, <code>\w</code> is equivalent to <code>[a-zA-Z_0-9]</code>	' <code>\w*</code> ' identifies a word.

Metacharacter	Description	Example
\W	Any character that is not alphabetic, numeric, or underscore. For English character sets, \W is equivalent to [^a-zA-Z_0-9]	'\W*' identifies a substring that is not a word.
\s	Any white-space character; equivalent to [ \f\n\r\t\v]	'\w*n\s' matches words that end with the letter n, followed by a white-space character.
\S	Any non-white-space character; equivalent to [^\f\n\r\t\v]	'\d\S' matches a numeric digit followed by any non-white-space character.
\d	Any numeric digit; equivalent to [0-9]	'\d*' matches any number of consecutive digits.
\D	Any nondigit character; equivalent to [^0-9]	'\w*\D\>' matches words that do not end with a numeric digit.
\oN or \o{N}	Character of octal value N	'\o{40}' matches the space character, defined by octal 40.
\xN or \x{N}	Character of hexadecimal value N	'\x2C' matches the comma character, defined by hex 2C.

### Character Representation

Operator	Description
\a	Alarm (beep)
\b	Backspace
\f	Form feed
\n	New line
\r	Carriage return
\t	Horizontal tab

Operator	Description
<code>\v</code>	Vertical tab
<code>\char</code>	Any character with special meaning in regular expressions that you want to match literally (for example, use <code>\\</code> to match a single backslash)

## Quantifiers

Quantifiers specify the number of times a string pattern must occur in the matching string.

Quantifier	Matches the expression when it occurs...	Example
<code>expr*</code>	0 or more times consecutively.	' <code>\w*</code> ' matches a word of any length.
<code>expr?</code>	0 times or 1 time.	' <code>\w*(\.\m)?</code> ' matches words that optionally end with the extension <code>.m</code> .
<code>expr+</code>	1 or more times consecutively.	' <code>&lt;img src="\w+\.\gif"&gt;</code> ' matches an <code>&lt;img&gt;</code> HTML tag when the file name contains one or more characters.
<code>expr{m,n}</code>	At least <code>m</code> times, but no more than <code>n</code> times consecutively. <code>{0,1}</code> is equivalent to <code>?</code> .	' <code>\S{4,8}</code> ' matches between four and eight non-white-space characters.
<code>expr{m,}</code>	At least <code>m</code> times consecutively. <code>{0,}</code> and <code>{1,}</code> are equivalent to <code>*</code> and <code>+</code> , respectively.	' <code>&lt;a href="\w{1,}\.html"&gt;</code> ' matches an <code>&lt;a&gt;</code> HTML tag when the file name contains one or more characters.
<code>expr{n}</code>	Exactly <code>n</code> times consecutively. Equivalent to <code>{n,n}</code> .	' <code>\d{4}</code> ' matches four consecutive digits.

Quantifiers can appear in three modes, described in the following table. `q` represents any of the quantifiers in the previous table.



Mode	Description	Example
<code>exprq</code>	Greedy expression: match as many characters as possible.	Given the string ' <code>&lt;tr&gt;&lt;td&gt;&lt;p&gt;text&lt;/p&gt;&lt;/td&gt;</code> ', the expression ' <code>&lt;/?t.*&gt;</code> ' matches all characters between <code>&lt;tr</code> and <code>/td&gt;</code> :  ' <code>&lt;tr&gt;&lt;td&gt;&lt;p&gt;text&lt;/p&gt;&lt;/td&gt;</code> '
<code>exprq?</code>	Lazy expression: match as few characters as necessary.	Given the string ' <code>&lt;tr&gt;&lt;td&gt;&lt;p&gt;text&lt;/p&gt;&lt;/td&gt;</code> ', the expression ' <code>&lt;/?t.*?&gt;</code> ' ends each match at the first occurrence of the closing bracket ( <code>&gt;</code> ):  ' <code>&lt;tr&gt;</code> '    ' <code>&lt;td&gt;</code> '    ' <code>&lt;/td&gt;</code> '
<code>exprq+</code>	Possessive expression: match as much as possible, but do not rescan any portions of the string.	Given the string ' <code>&lt;tr&gt;&lt;td&gt;&lt;p&gt;text&lt;/p&gt;&lt;/td&gt;</code> ', the expression ' <code>&lt;/?t.*+&gt;</code> ' does not return any matches, because the closing bracket is captured using <code>.*</code> , and is not rescanned.

### Grouping Operators

Grouping operators allow you to capture tokens, apply one operator to multiple elements, or disable backtracking in a specific group.

# regexprep

Grouping Operator	Description	Example
(expr)	Group elements of the expression and capture tokens.	'Joh?n\s(\w*)' captures a token that contains the last name of any person with the first name John or Jon.
(?:expr)	Group, but do not capture tokens.	'(?:[aeiou][^aeiou]){2}' matches two consecutive patterns of a vowel followed by a nonvowel, such as 'anon'.  Without grouping, '[aeiou][^aeiou]{2}' matches a vowel followed by two nonvowels.
(?>expr)	Group atomically. Do not backtrack within the group to complete the match, and do not capture tokens.	'A(?>.* )Z' does not match 'AtoZ', although 'A(?:.* )Z' does. Using the atomic group, Z is captured using .* and is not rescanned.
(expr1 expr2)	Match expression expr1 or expression expr2.  If there is a match with expr1, then expr2 is ignored.  You can include ?: or ?> after the opening parenthesis to suppress tokens or group atomically.	'(let tel)\w+' matches words in a string that start with let or tel.

## Anchors

Anchors in the expression match the beginning or end of the string or word.

Anchor	Matches the...	Example
<code>^expr</code>	Beginning of the input string.	' <code>^M\w*</code> ' matches a word starting with <code>M</code> at the beginning of the string.
<code>expr\$</code>	End of the input string.	' <code>\w*m\$</code> ' matches words ending with <code>m</code> at the end of the string.
<code>\&lt;expr</code>	Beginning of a word.	' <code>\&lt;n\w*</code> ' matches any words starting with <code>n</code> .
<code>expr\&gt;</code>	End of a word.	' <code>\w*e\&gt;</code> ' matches any words ending with <code>e</code> .

### Lookaround Assertions

Lookaround assertions look for string patterns that immediately precede or follow the intended match, but are not part of the match.

The pointer remains at the current location, and characters that correspond to the `test` expression are not captured or discarded. Therefore, lookahead assertions can match overlapping character groups.

Lookaround Assertion	Description	Example
<code>expr(=?test)</code>	Look ahead for characters that match <code>test</code> .	' <code>\w*(?=ing)</code> ' matches strings that are followed by <code>ing</code> , such as 'Fly' and 'fall' in the input string 'Flying, not falling.'
<code>expr(?!test)</code>	Look ahead for characters that do not match <code>test</code> .	' <code>i(?!ng)</code> ' matches instances of the letter <code>i</code> that are not followed by <code>ng</code> .

Lookaround Assertion	Description	Example
<code>(?&lt;=test)expr</code>	Look behind for characters that match test..	'(?<=re)\w*' matches strings that follow 're', such as 'new', 'use', and 'cycle' in the input string 'renew, reuse, recycle'
<code>(?&lt;!test)expr</code>	Look behind for characters that do not match test.	'(?<!\d)(\d)(?!\d)' matches single-digit numbers (digits that do not precede or follow other digits).

If you specify a lookahead assertion *before* an expression, the operation is equivalent to a logical AND.

Operation	Description	Example
<code>(?=test)expr</code>	Match both test and expr.	'(?=[a-z])[^aeiou]' matches consonants.
<code>(?!test)expr</code>	Match expr and do not match test.	'(?![aeiou])[a-z]' matches consonants.

## Logical and Conditional Operators

Logical and conditional operators allow you to test the state of a given condition, and then use the outcome to determine which string, if any, to match next. These operators support logical OR, and if or if/else conditions.

Conditions can be tokens, lookaround operators, or dynamic expressions of the form `(?@cmd)`. Dynamic expressions must return a logical or numeric value.

Conditional Operator	Description	Example
<code>expr1 expr2</code>	Match expression <code>expr1</code> or expression <code>expr2</code> . If there is a match with <code>expr1</code> , then <code>expr2</code> is ignored.	' <code>(let tel)\w+</code> ' matches words in a string that start with <code>let</code> or <code>tel</code> .
<code>(?(cond)expr)</code>	If condition <code>cond</code> is true, then match <code>expr</code> .	' <code>(?(?@ispc)[A-Z]:\\)</code> ' matches a drive name, such as <code>C:\</code> , when run on a Windows system.
<code>(?(cond)expr1 expr2)</code>	If condition <code>cond</code> is true, then match <code>expr1</code> . Otherwise, match <code>expr2</code> .	' <code>Mr(s?)\..*?(?(1)her his)\w*</code> ' matches strings that include <code>her</code> when the string begins with <code>Mrs</code> , or that include <code>his</code> when the string begins with <code>Mr</code> .

### Token Operators

Tokens are portions of the matched text that you define by enclosing part of the regular expression in parentheses. You can refer to a token by its sequence in the string (an ordinal token), or assign names to tokens for easier code maintenance and readable output.

Ordinal Token Operator	Description	Example
<code>(expr)</code>	Capture in a token the characters that match the enclosed expression.	' <code>Joh?n\s(\w*)</code> ' captures a token that contains the last name of any person with the first name <code>John</code> or <code>Jon</code> .
<code>\N</code>	Match the Nth token.	' <code>&lt;(\w+).*&gt;.*&lt;/\1&gt;</code> ' captures tokens for HTML tags, such

# regexprep

Ordinal Token Operator	Description	Example
		as 'title' from the string '<title>Some text</title>'.
(?(N)expr1 expr2)	If the Nth token is found, then match expr1. Otherwise, match expr2.	'Mr(s?)\..*?(?(1)her his)\w*' matches strings that include her when the string begins with Mrs, or that include his when the string begins with Mr.

Named Token Operator	Description	Example
(?<name>expr)	Capture in a named token the characters that match the enclosed expression.	'(?<month>\d+)-(?<day>\d+)-(?<yr>\d+)' creates named tokens for the month, day, and year in an input date string of the form mm-dd-yy.
\k<name>	Match the token referred to by name.	'<(?(tag>\w+).*>.*</\k<tag>>'' captures tokens for HTML tags, such as 'title' from the string '<title>Some text</title>'.
(?(name)expr1 expr2)	If the named token is found, then match expr1. Otherwise, match expr2.	'Mr(?(sex>s?)\..*?(?(sex)her his)\w*' matches strings that include her when the string begins with Mrs, or that include his when the string begins with Mr.

**Note** If an expression has nested parentheses, MATLAB captures tokens that correspond to the outermost set of parentheses. For example, given the search pattern '(and(y|rew))', MATLAB creates a token for 'andrew' but not for 'y' or 'rew'.

### Dynamic Regular Expressions

Dynamic expressions allow you to execute a MATLAB command or a regular expression to determine the text to match.

The parentheses that enclose dynamic expressions do *not* create a capturing group.

Operator	Description	Example
(??expr)	Parse expr and include the resulting string in the match expression.  When parsed, expr must correspond to a complete, valid regular expression. Dynamic expressions that use the backslash escape character (\) require two backslashes: one for the initial parsing of expr, and one for the complete match.	'^(\d+)(??\w{\$1})' determines how many characters to match by reading a digit at the beginning of the string. The dynamic expression is enclosed in a second set of parentheses so that the resulting match is captured in a token. For instance, matching '5XXXXX' captures tokens for '5' and 'XXXXX'.
(??@cmd)	Execute the MATLAB command represented by cmd, and include the string returned by the command in the match expression.	'(.{2,}).?(??@fliplr(\$1))' finds palindromes that are at least four characters long, such as 'abba'.
(?@cmd)	Execute the MATLAB command represented by cmd, but discard any output the command returns. (Helpful for diagnosing regular expressions.)	'\w*?(\w)(?@disp(\$1))\1\w*' matches words that include double letters (such as pp), and displays intermediate results.

# regexprep

---

Within dynamic expressions, use the following operators to define replacement strings.

Replacement String Operator	Description
<code>&amp;</code> or <code>\$0</code>	Portion of the input string that is currently a match
<code>\$`</code>	Portion of the input string that precedes the current match
<code>\$'</code>	Portion of the input string that follows the current match (use <code>\$''</code> to represent the string <code>\$'</code> )
<code>\$N</code>	Nth token
<code>\$&lt;name&gt;</code>	Named token
<code>\${cmd}</code>	String returned when MATLAB executes the command, <code>cmd</code>

## Comments

Characters	Description	Example
<code>(?#comment)</code>	Insert a comment in the regular expression. The comment text is ignored when matching the input string.	<code>'(?# Initial digit)\&lt;\d\w+'</code> includes a comment, and matches words that begin with a number.

## Search Flags

Search flags modify the behavior for matching expressions. An alternative to using a search flag within an expression is to pass an option input argument.

Flag	Description
<code>(?-i)</code>	Match letter case (default for <code>regexp</code> and <code>regexprep</code> ).
<code>(?i)</code>	Do not match letter case (default for <code>regexp</code> ).



Flag	Description
(?s)	Match dot (.) in the pattern string with any character (default).
(?-s)	Match dot in the pattern with any character that is not a newline character.
(?-m)	Match the ^ and \$ metacharacters at the beginning and end of a string (default).
(?m)	Match the ^ and \$ metacharacters at the beginning and end of a line.
(?-x)	Include space characters and comments when matching (default).
(?x)	Ignore space characters and comments when matching. Use '\ ' and '\#' to match space and # characters.

The expression that the flag modifies can appear either after the parentheses, such as

```
(?i)\w*
```

or inside the parentheses and separated from the flag with a colon (:), such as

```
(?i:\w*)
```

The latter syntax allows you to change the behavior for part of a larger expression.

### Data Types

char | cell

### replace - Replacement text

string | cell array of strings

Replacement text, specified as a string or a cell array of strings, as follows:

- If `replace` is a single string and `expression` is a cell array of strings, then `regexprep` uses the same replacement text for each expression.

# regexprep

- If `replace` is a cell array of  $N$  strings and `expression` is a single string, then `regexprep` attempts  $N$  matches and replacements.
- If both `replace` and `expression` are cell arrays of strings, then they must contain the same number of elements. `regexprep` pairs each `replace` element with its matching element in `expression`.

The replacement text can include regular characters, special characters (such as tabs or new lines), or string operators, as shown in the following tables.

Replacement String Operator	Description
<code>\$&amp;</code> or <code>\$0</code>	Portion of the input string that is currently a match
<code>\$`</code>	Portion of the input string that precedes the current match
<code>\$'</code>	Portion of the input string that follows the current match (use <code>\$''</code> to represent the string <code>\$'</code> )
<code>\$N</code>	$N$ th token
<code>\$(name)</code>	Named token
<code>\$(cmd)</code>	String returned when MATLAB executes the command, <code>cmd</code>

Operator	Description
<code>\a</code>	Alarm (beep)
<code>\b</code>	Backspace
<code>\f</code>	Form feed
<code>\n</code>	New line
<code>\r</code>	Carriage return
<code>\t</code>	Horizontal tab

Operator	Description
<code>\v</code>	Vertical tab
<code>\char</code>	Any character with special meaning in regular expressions that you want to match literally (for example, use <code>\\</code> to match a single backslash)

**Data Types**

char | cell

**option - Search or replacement option**

'once' | N | 'warnings' | 'ignorecase' | 'preservecase' | 'emptymatch' | 'dotexceptnewline' | 'lineanchors' | ...

Search or replacement option, specified as a string or an integer value, as shown in the following table.

Options come in sets: one option that corresponds to the default behavior, and one or two options that allow you to override the default. Specify only one option from a set. Options can appear in any order.

Default	Override	Description
'all'	'once'	Match and replace the expression as many times as possible (default), or only once.
	N	Replace only the Nth occurrence of the match, where N is an integer value.
'nowarnings'	'warnings'	Suppress warnings (default), or display them.
'matchcase'	'ignorecase'	Match letter case (default), or ignore case while matching and replacing.
	'preservecase'	Ignore case while matching, but preserve the case of corresponding characters in the original string while replacing.
'noemptymatch'	'emptymatch'	Ignore zero length matches (default), or include them.

# regexprep

---

Default	Override	Description
'dotall'	'dotexceptnewline'	Match dot with any character (default), or all except newline (\n).
'stringanchors'	'lineanchors'	Apply ^ and \$ metacharacters to the beginning and end of a string (default), or to the beginning and end of a line.
'literalspacing'	'freespacing'	Include space characters and comments when matching (default), or ignore them. With freespacing, use '\ ' and '\#' to match space and # characters.

## Data Types

char

## Output Arguments

### newStr - Updated text

string | cell array of strings

Updated text, returned as a string or a cell array of strings. The data type of newStr is the same as the data type of str.

## Examples

### Update a Single String

Replace words that begin with M, end with y, and have at least one character between them.

```
str = 'My flowers may bloom in May';
expression = 'M(\w+)y';
replace = 'April';
```

```
newStr = regexprep(str,expression,replace)
```

```
newStr =
```

```
My flowers may bloom in April
```

### Include Tokens in Replacement Text

Replace variations of the phrase 'walk up' by capturing the letters that follow 'walk' in a token.

```
str = 'I walk up, they walked up, we are walking up.';
expression = 'walk(\w*) up';
replace = 'ascend$1';
```

```
newStr = regexprep(str,expression,replace)
```

```
newStr =
```

```
I ascend, they ascended, we are ascending.
```

### Include Dynamic Expression in Replacement Text

Replace lowercase letters at the beginning of sentences with their uppercase equivalents using the upper function.

```
str = 'here are two sentences. neither is capitalized.';
expression = '^(|\.)\s*.';
replace = '${upper($0)}';
```

```
newStr = regexprep(str,expression,replace)
```

```
newStr =
```

```
Here are two sentences. Neither is capitalized.
```

The regular expression matches single characters (.) that follow the beginning of the string (^) or a period (\.) and any whitespace (\s\*). The replace expression calls the upper function for the currently matching character (\$0).

### Update Multiple Strings

Replace each occurrence of a double letter in a set of strings with the symbols '--'.

```
str = {
 'Whose woods these are I think I know.' ; ...
 'His house is in the village though;' ; ...
 'He will not see me stopping here' ; ...
 'To watch his woods fill up with snow.'};

expression = '(.)\1';
replace = '--';
newStr = regexprep(str,expression,replace)

newStr =

 'Whose w--ds these are I think I know.'
 'His house is in the vi--age though;'
 'He wi-- not s-- me sto--ing here'
 'To watch his w--ds fi-- up with snow.'
```

## Preserve Case in Original String

Ignore letter case in the regular expression when finding matches, but mimic the letter case of the original string when updating.

```
str = 'My flowers may bloom in May';
expression = 'M(\w+)y';
replace = 'April';

newStr = regexprep(str,expression,replace,'preserveCase')

newStr =

My flowers april bloom in April
```

## Replace Zero-Length Matches

Insert text at the beginning of a string using the '^' operator, which returns a zero-length match, and the 'emptyMatch' keyword.

```
str = 'abc';
expression = '^';
```

```
replace = '__';
newStr = regexprep(str,expression,replace,'emptymatch')

newStr =

__abc
```

## See Also

[regexp](#) | [strcmp](#) | [strfind](#) | [strrep](#)

## Concepts

- “Lookahead Assertions in Regular Expressions”
- “Tokens in Regular Expressions”
- “Dynamic Regular Expressions”

# regexptranslate

---

**Purpose** Translate string into regular expression

**Syntax** `s2 = regexptranslate(type, s1)`

**Description** `s2 = regexptranslate(type, s1)` translates string `s1` into a regular expression string `s2` that you can then use as input into one of the MATLAB regular expression functions such as `regexp`. The `type` input can be either one of the following strings that define the type of translation to be performed. See “Regular Expressions” in the MATLAB Programming Fundamentals documentation for more information.

Type	Description
'escape'	Translate all special characters (e.g., '\$', '.', '?', '[') in string <code>s1</code> so that they are treated as literal characters when used in the <code>regexp</code> and <code>regexprep</code> functions. The translation inserts an escape character ('\') before each special character in <code>s1</code> . Return the new string in <code>s2</code> .
'wildcard'	Translate all wildcard and '.' characters in string <code>s1</code> so that they are treated as literal wildcards and periods when used in the <code>regexp</code> and <code>regexprep</code> functions. The translation replaces all instances of '*' with '.', all instances of '?' with '.', and all instances of '.' with '\.'. Return the new string in <code>s2</code> .

## Examples

### Example 1 – Using the 'escape' Option

Because `regexp` interprets the sequence `\n` as a newline character, it cannot locate the two consecutive characters `\` and `n` in this string:

```
str = 'The sequence \n generates a new line';
pat = '\n';

regexp(str, pat)
ans =
 []
```



To have `regexp` interpret the expression `expr` as the characters ``\`` and ``n``, first translate the expression using `regexptranslate`:

```
pat2 = regexptranslate('escape', pat)
pat2 =
 \\n

regexp(str, pat2)
ans =
 14
```

## Example 2 – Using 'escape' In a Replacement String

Replace the word 'walk' with 'ascend' in this string, treating the characters '\$1' as a token designator:

```
str = 'I walk up, they walked up, we are walking up.';
pat = 'walk(\w*) up';

regexprprep(str, pat, 'ascend$1')
ans =
 I ascend, they ascended, we are ascending.
```

Make another replacement on the same string, this time treating the '\$1' as literal characters:

```
regexprprep(str, pat, regexptranslate('escape', 'ascend$1'))
ans =
 I ascend$1, they ascend$1, we are ascend$1.
```

## Example 3 – Using the 'wildcard' Option

Given the following string of filenames, pick out just the MAT-files. Use `regexptranslate` to interpret the '\*' wildcard as '\w+' instead of as a regular expression quantifier:

```
files = ['test1.mat, myfile.mat, newfile.txt, ' ...
 'jan30.mat, table3.xls'];
regexp(files, regexptranslate('wildcard', '*.mat'), 'match')
```

# regextranslate

---

```
ans =
 'test1.mat, myfile.mat, newfile.txt, jan30.mat'
```

To see the translation, you can type

```
regextranslate('wildcard', '*.mat')
ans =
 \w+\.mat
```

## See Also

[regexp](#) | [regexpi](#) | [regexprep](#)

## How To

- “Regular Expressions”

**Purpose** Associate event handler for COM object event at run time

**Syntax** `h.registerevent(eventhandler)`  
`registerevent(h, eventhandler)`

**Description** `h.registerevent(eventhandler)` registers event handler routines with their corresponding events. The `eventhandler` argument can be either a string that specifies the name of the event handler function, or a function handle that maps to that function. Strings used in the `eventhandler` argument are not case sensitive.

`registerevent(h, eventhandler)` is an alternate syntax.

COM functions are available on Microsoft Windows systems only.

**Examples** Show events in the MATLAB sample control:

```
f = figure ('position', [100 200 200 200]);
h = actxcontrol ('mwsamp.mwsampctrl.2', [0 0 200 200], f);
h.events
```

```
Click = void Click()
DbClick = void DbClick()
MouseDown = void MouseDown(int16 Button, int16 Shift,
 Variant x, Variant y)
Event_Args = void Event_Args(int16 typeshort,
 int32 typelong, double typedouble, string typestring,
 bool typebool)
```

MATLAB displays all events associated with the instance of the control.

Register all events with the same event handler routine, `sampev`:

```
h.registerevent('sampev');
h.eventlisteners
```

```
ans =
 'Click' 'sampev'
```

# registerevent

---

```
'Db1Click' 'sampev'
'MouseDown' 'sampev'
'Event_Args' 'sampev'
```

---

Register individual events:

```
%Unregister existing events
h.unregisterallevents;
%Register specific events
h.registerevent({'click' 'myclick'; ...
 'dblclick' 'my2click'});
h.eventlisteners
```

```
ans =
 'click' 'myclick'
 'dblclick' 'my2click'
```

---

Register events using a function handle (@sampev) instead of the function name:

```
h = actxcontrol('mwsamp.mwsampctrl.2', [0 0 200 200]);
registerevent(h, @sampev);
```

## See Also

events (COM) | eventlisteners | unregisterevent |  
unregisterallevents | isevent

## How To

- “Writing Event Handlers”

**Purpose** Refresh function and file system path caches

**Syntax**

```
rehash
rehash path
rehash toolbox
rehash pathreset
rehash toolboxreset
rehash toolboxcache
```

**Description** rehash with no arguments updates the MATLAB list of known files and classes for directories on the search path that are not in *matlabroot*/toolbox. It compares the timestamps for loaded functions against their timestamps on disk. It clears loaded functions if the files on disk are newer. All of this normally happens each time MATLAB displays the Command Window prompt. Use rehash with no arguments only when you run a program file that updates another program file, and the calling file needs to reuse the updated version of the second file before the calling file has finished running.

rehash **path** performs the same updates as rehash, but uses a different technique for detecting the files and directories that require updates. Run rehash path only if you receive a warning during MATLAB startup notifying you that MATLAB could not tell if a directory has changed, and you encounter problems with MATLAB not using the most current versions of your program files.

rehash **toolbox** performs the same updates as rehash path, except it updates the list of known files and classes for *all* directories on the search path, including those in *matlabroot*/toolbox. Run rehash toolbox when you change, add, or remove files in *matlabroot*/toolbox during a session. Typically, you should not make changes to files and directories in *matlabroot*/toolbox.

rehash **pathreset** performs the same updates as rehash **path**, and also ensures the known files and classes list follows precedence rules for shadowed functions.

# rehash

---

`rehash toolboxreset` performs the same updates as `rehash toolbox`, and also ensures the known files and classes list follows precedence rules for shadowed functions.

`rehash toolboxcache` performs the same updates as `rehash toolbox`, and also updates the cache file. This is the equivalent of clicking the **Update Toolbox Path Cache** button in the General Preferences dialog box.

## See Also

`addpath` | `clear` | `matlabroot` | `path` | `rmpath`

## How To

- “Toolbox Path Caching in MATLAB”
- “What Is the MATLAB Search Path?”

**Purpose** Release COM interface

**Syntax** `h.release`  
`release(h)`

**Description** `h.release` releases the interface and all resources used by the interface. You must release the handle when you are done with the interface. A released interface is no longer valid. MATLAB generates an error if you try to use an object that represents that interface.

`release(h)` is an alternate syntax.

Releasing the interface does not delete the control itself (see the `delete` function), since other interfaces on that object might still be active.

COM functions are available on Microsoft Windows systems only.

**See Also** `delete (COM)` | `actxcontrol` | `actxserver`

**How To**

- Releasing Interfaces

# Relational Operators (handle)

---

**Purpose** Equality and sorting of handle objects

**Syntax**

```
TF = eq(H1,H2)
TF = ne(H1,H2)
TF = lt(H1,H2)
TF = le(H1,H2)
TF = gt(H1,H2)
TF = ge(H1,H2)
```

**Description**

```
TF = eq(H1,H2)
TF = ne(H1,H2)
TF = lt(H1,H2)
TF = le(H1,H2)
TF = gt(H1,H2)
TF = ge(H1,H2)
```

For each pair of input arrays (H1 and H2), a logical array of the same size is returned in which each element is an element-wise equality or comparison test result. These methods perform scalar expansion in the same way as the MATLAB built-in functions. See [relationaloperators](#) for more information.

You can make the following assumptions about the result of a handle comparison:

- The same two handles always compare as equal and the repeated comparison of any two handles always yields the same result in the same MATLAB session.
- Different handles are always not-equal.
- The order of handle values is purely arbitrary and has no connection to the state of the handle objects being compared.
- If the input arrays belong to different classes (including the case where one input array belongs to a non-handle class such as `double`) then the comparison is always false.



- If a comparison is made between a handle object and an object of a dominant class, the method of the dominant class is invoked. You should generally test only like objects because a dominant class might not define one of these methods.
- An error occurs if the input arrays are not the same size and neither is scalar.

Use `isequal` when you want to determine if handle objects with different handles have the same data in all object properties.

## See Also

`handle` | `meta.class`

# rem

---

**Purpose**            Remainder after division

**Syntax**            `R = rem(X,Y)`

**Description**        `R = rem(X,Y)` returns the remainder after division of `X` by `Y`. In general, if `Y` does not equal 0, `R = rem(X,Y)` returns `X - n.*Y`, where `n = fix(X./Y)`. If `Y` is not an integer and the quotient `X./Y` is within roundoff error of an integer, then `n` is that integer. Inputs `X` and `Y` must have the same dimensions unless one of them is a scalar double. If one of the inputs has an integer data type, then the other input must be of the same integer data type or be a scalar double.

The following are true by convention:

- `rem(X,0)` is NaN.
- `rem(X,X)` for `X~=0` is 0.
- `rem(X,Y)` for `X~=Y` and `Y~=0` has the same sign as `X`.

## **Input Arguments**

### **X - Dividend**

scalar | vector | matrix | multidimensional array

Dividend, specified as a scalar, vector, matrix, or multidimensional array. Must be a real-valued number of any numerical type.

### **Data Types**

single | double | int8 | int16 | int32 | int64 | uint8 | uint16 | uint32 | uint64 | char

### **Y - Divisor**

scalar | vector | matrix | multidimensional array

Divisor, specified as a scalar, vector, matrix, or multidimensional array. Must be a real-valued number of any numerical type.

### **Data Types**

single | double | int8 | int16 | int32 | int64 | uint8 | uint16 | uint32 | uint64 | char

**Examples****Remainder of Two Scalars**

Compute the remainder after dividing 5 into 23.

```
X = 23;
Y = 5;
R = rem(X,Y)
```

R =

3

**Remainder of a Vector**

Create a vector, then use `rem` to find the remainder after dividing a scalar into each element of the vector.

```
X = 1:5;
Y = 3;
R = rem(X,Y)
```

R =

1 2 0 1 2

When you specify one or more of the inputs as an array, the `rem` function acts on each array element independently.

**Remainder of Two Arrays**

Create two 3-by-3 matrices, then use `rem` to find the remainder after dividing Y into X.

```
X = [1 2 3;4 5 6;7 8 9];
Y = [9 8 7;6 5 4;3 2 1];
R = rem(X,Y)
```

R =

1 2 3

```
4 0 2
1 0 0
```

Inputs  $X$  and  $Y$  must have the same dimensions unless one is a scalar double.

## Forced Rounding in rem

If  $Y$  is not an integer and  $X./Y$  is within roundoff error of an integer, then `rem` rounds to that integer for its calculation. The size of the roundoff error is very small.

```
X = 2;
Y = 2 - eps(2)
```

```
Y =
```

```
2.0000
```

It looks like  $Y$  is trivially equal to 2, but in fact there is an infinitesimal difference.

```
2 - Y
```

```
ans =
```

```
4.4409e-16
```

This difference is forced to zero by `rem` if it is small enough.

```
R = rem(X,Y)
```

```
R =
```

```
0
```

Make the difference a little larger and the forced rounding disappears.

```
Y = 2 - eps(4);
```

```
R = rem(X,Y)
```

```
R =
```

```
8.8818e-16
```

### **Difference Between rem and mod**

Define X and Y with different signs.

```
X = 5;
```

```
Y = -2;
```

Compute the remainder after division with `rem`, then compute the modulus after division with `mod`.

```
R = rem(X,Y)
```

```
R =
```

```
1
```

```
M = mod(X,Y)
```

```
M =
```

```
-1
```

`rem(X,Y)` and `mod(X,Y)` are equal if X and Y have the same sign, but differ by Y if X and Y have different signs. Notice that `rem` retains the sign of X, while `mod` retains the sign of Y.

### **See Also**

`mod`

# containers.Map.remove

---

**Purpose** Remove key-value pairs from containers.Map object

**Syntax** remove(mapObj, keySet)

**Description** remove(mapObj, keySet) erases all specified keys, and the values associated with them, from mapObj. Input keySet can be a scalar key or a cell array of keys.

**Input Arguments**

**mapObj**  
Object of class containers.Map.

**keySet**  
Scalar value, string, or cell array that specifies keys in mapObj to delete.

## Examples Remove Key-Value Pairs from a Map

Create a map and view the keys and the Count property:

```
myKeys = {'a', 'b', 'c', 'd'};
myValues = [1,2,3,4];
mapObj = containers.Map(myKeys, myValues);
```

```
mapKeys = keys(mapObj)
mapCount = mapObj.Count
```

The initial map contains four key-value pairs:

```
mapKeys =
 'a' 'b' 'c' 'd'
```

```
mapCount =
 4
```

Remove the pairs corresponding to keys b and d:

```
keySet = {'b', 'd'};
```

```
remove(mapObj, keySet)

mapKeys = keys(mapObj)
mapCount = mapObj.Count
```

The modified map contains two key-value pairs:

```
mapKeys =
 'a' 'c'

mapCount =
 2
```

### See Also

[containers.Map](#) | [keys](#) | [values](#) | [isKey](#)

# removecats

---

**Purpose** Remove categories from categorical array

**Syntax**  
B = removecats(A)  
B = removecats(A,oldcats)

**Description** B = removecats(A) removes unused categories from the categorical array, A. The output categorical array, B, has the same size and values as A. However, B possibly has fewer categories.

B = removecats(A,oldcats) removes the categories specified by oldcats. The function removecats removes categories, but does not remove any elements of the array. Therefore, elements of B, whose values correspond to oldcats, are undefined.

## Input Arguments

**A - Categorical array**  
vector | matrix | multidimensional array

Categorical array, specified as a vector, matrix, or multidimensional array.

### **oldcats - Categories to remove**

string | cell array of strings

Categories to remove, specified as a string or cell array of strings. The default is all the unused categories from A.

## Examples

### **Remove All Unused Categories**

Create a categorical array representing political parties of four people.

```
A = categorical({'republican' 'democrat' 'democrat' 'republican'},...
 {'democrat' 'republican' 'independent'})
```

```
A =
```

```
 republican democrat democrat republican
```

A is a 1-by-4 categorical array.



Summarize the categorical array, A.

```
summary(A)
```

```

 democrat republican independent
 2 2 0

```

A has three categories. `democrat` appears twice in the array, `republican` appears twice in the array, and `independent` is unused.

Remove the unused category, `independent`.

```
B = removecats(A)
```

```
B =
```

```

 republican democrat democrat republican

```

B has the same values as A.

Display the categories of B.

```
categories(B)
```

```
ans =
```

```

 'democrat'
 'republican'

```

B has fewer categories than A.

### **Remove Categories with Corresponding Values Used in A**

Create a categorical array, A, containing modes of transportation.

```
A = categorical({'plane' 'car'; 'train' 'car'; 'plane' 'car'})
```

```
A =
```

```

 plane car

```

## removecats

---

```
 train car
 plane car
```

A is a 3-by-2 categorical array.

Display the categories of A.

```
categories(A)
```

```
ans =
```

```
 'car'
 'plane'
 'train'
```

A has three categories, car, plane, and train.

Remove the category, train.

```
B = removecats(A, 'train')
```

```
B =
```

```
 plane car
 <undefined> car
 plane car
```

The element that was from the category train is now undefined.

Display the categories of B.

```
categories(B)
```

```
ans =
```

```
 'car'
 'plane'
```

B has one fewer category than A.

## Tips

- `~ismember(categories(A),unique(A))` returns logical true (1) for any unused category of A.

## See Also

`categories` | `summary` | `addcats` | `iscategory` | `mergecats` |  
`renamecats` | `reordercats`

# removets

---

**Purpose** Remove timeseries objects from tscollection object

**Syntax** `tsc = removets(tsc,Name)`

**Description** `tsc = removets(tsc,Name)` removes one or more timeseries objects with the name specified in Name from the tscollection object tsc. Name can either be a string or a cell array of strings.

**Examples** The following example shows how to remove a time series from a tscollection.

**1** Create two timeseries objects, ts1 and ts2.

```
ts1=timeseries([1.1 2.9 3.7 4.0 3.0],1:5,'name','acceleration');
ts2=timeseries([3.2 4.2 6.2 8.5 1.1],1:5,'name','speed');
```

**2** Create a tscollection object tsc, which includes ts1 and ts2.

```
tsc=tscollection({ts1 ts2});
```

**3** To view the members of tsc, type the following at the MATLAB prompt:

```
tsc
```

The response is

```
Time Series Collection Object: unnamed
```

```
Time vector characteristics
```

```
Start time 1 seconds
End time 5 seconds
```

```
Member Time Series Objects:
```

```
acceleration
speed
```

The members of `tsc` are listed by name at the bottom: `acceleration` and `speed`. These are the `Name` properties of `ts1` and `ts2`, respectively.

- 4 Remove `ts2` from `tsc`.

```
tsc=removets(tsc,'speed');
```

- 5 To view the current members of `tsc`, type the following at the MATLAB prompt:

```
tsc
```

The response is

```
Time Series Collection Object: unnamed
```

```
Time vector characteristics
```

```
Start time 1 seconds
End time 5 seconds
```

```
Member Time Series Objects:
acceleration
```

The remaining member of `tsc` is `acceleration`. The timeseries `speed` has been removed.

## See Also

`addts` | `tscollection`

# renamecats

---

## Purpose

Rename categories in categorical array

## Syntax

```
B = renamecats(A,newnames)
B = renamecats(A,oldnames,newnames)
```

## Description

`B = renamecats(A,newnames)` renames all the categories in the categorical array, `A`. Elements of `B` use the new category names.

`B = renamecats(A,oldnames,newnames)` renames only the categories specified by `oldnames`.

## Input Arguments

### **A - Categorical array**

vector | matrix | multidimensional array

Categorical array, specified as a vector, matrix, or multidimensional array.

### **newnames - New category names for B**

string | cell array of strings

New category names for `B`, specified as a string or a cell array of strings. The new category names must be unique, and must not duplicate any existing names.

### **oldnames - Old category names from A**

string | cell array of strings

Old category names from `A`, specified as a string or a cell array of strings.

## Examples

### **Rename All Categories**

Create a categorical array containing states from New England.

```
A = categorical({'MA'; 'ME'; 'CT'; 'VT'; 'ME'; 'NH'; 'VT'; 'MA'; 'NH'; 'CT'; 'RI'})
```

```
A =
```

```
 MA
```

```
ME
CT
VT
ME
NH
VT
MA
NH
CT
RI
```

A is an 11-by-1 categorical array.

Display the categories of A.

```
categories(A)
```

```
ans =
```

```
'CT'
'MA'
'ME'
'NH'
'RI'
'VT'
```

A has six categories.

Rename the categories to use the full state name instead of the abbreviation.

```
B = renamecats(A,{'Connecticut','Massachusetts',...
 'Maine','New Hampshire','Rhode Island','Vermont'})
```

```
B =
```

```
Massachusetts
Maine
```

# renamecats

---

```
Connecticut
Vermont
Maine
New Hampshire
Vermont
Massachusetts
New Hampshire
Connecticut
Rhode Island
```

Elements of **B** use the new category names.

Display the categories of **B**.

```
categories(B)
```

```
ans =
```

```
'Connecticut'
'Massachusetts'
'Maine'
'New Hampshire'
'Rhode Island'
'Vermont'
```

## **Rename One Category**

Create a categorical array containing colors.

```
A = categorical({'red' 'blue'; 'purple' 'white'; 'green' 'red'})
```

```
A =
```

```
red blue
purple white
green red
```

A is a 3-by-2 categorical array.



Display the categories of A.

```
categories(A)
```

```
ans =
```

```
'blue'
'green'
'purple'
'red'
'white'
```

A has five categories that are listed in alphabetical order.

Change the category name from purple to violet.

```
B = renamecats(A, 'purple', 'violet')
```

```
B =
```

```
 red blue
violet white
green red
```

The element B(2,1) is violet instead of purple.

Display the categories of B.

```
categories(B)
```

```
ans =
```

```
'blue'
'green'
'violet'
'red'
'white'
```

## renamecats

---

violet replaces purple and the categories are no longer in alphabetical order. Note that the category has not changed its position.

### Tips

- Renaming categories does not change their position in `categories(B)`. Use `reordercats` to change the category ordering. For example, you can use `B = reordercats(B, sort(categories(B)))` to put the categories in alphabetical order.

### See Also

`categories` | `addcats` | `removecats` | `iscategory` | `mergecats` | `reordercats`

<b>Purpose</b>	Reorder categories in categorical array
<b>Syntax</b>	<pre>B = reordercats(A) B = reordercats(A,neworder)</pre>
<b>Description</b>	<p><code>B = reordercats(A)</code> reorders the categories in the categorical array, <code>A</code>, to be in alphanumeric order.</p> <p>The order of the categories is used by functions such as <code>summary</code> and <code>hist</code>. Furthermore, if the categorical array is ordinal, the order of the categories defines their mathematical ordering. The first category specified is the smallest and the last category is the largest.</p> <p><code>B = reordercats(A,neworder)</code> puts the categories in the order specified by <code>neworder</code>.</p>
<b>Input Arguments</b>	<p><b>A - Categorical array</b> vector   matrix   multidimensional array</p> <p>Categorical array, specified as a vector, matrix, or multidimensional array. If <code>A</code> is an ordinal categorical array, a reordering of the categories changes the mathematical meaning. Consequently, the relational operators, such as greater than and less than, might return different results.</p> <p><b>neworder - New category order for B</b> cell array of strings</p> <p>New category order for <code>B</code>, specified as a cell array of strings. <code>neworder</code> must be a permutation of <code>categories(A)</code>.</p>
<b>Examples</b>	<p><b>Alphabetize Categories of Nonordinal Categorical Array</b></p> <p>Create two categorical arrays, <code>X</code> and <code>Y</code>.</p> <pre>X = categorical({'frog';'cat';'cat';'ant';'frog'}) Y = categorical({'deer';'bear';'eagle';'deer'})</pre>

# reordercats

---

X =

```
frog
cat
cat
ant
frog
```

Y =

```
deer
bear
eagle
deer
```

X is a 5-by-1 categorical array. The categories of X are the sorted unique values from the array: {'ant'; 'cat'; 'frog'}.

Y is a 4-by-1 categorical array. The categories of Y are the sorted unique values from the array: {'bear'; 'deer'; 'eagle'}.

Concatenate X and Y into a single categorical array, A.

A = [X;Y]

A =

```
frog
cat
cat
ant
frog
deer
bear
eagle
deer
```

`vertcat` appends the values from `Y` to the values from `X`.

List the categories of the categorical array, `A`.

```
acats = categories(A)
```

```
acats =

 'ant'
 'cat'
 'frog'
 'bear'
 'deer'
 'eagle'
```

`vertcat` appends the categories of `Y` to the categories from `X`. The categories of `A` are *not* in alphabetical order.

Reorder the categories of `A` into alphabetical order.

```
B = reordercats(A)
```

```
B =

 frog
 cat
 cat
 ant
 frog
 deer
 bear
 eagle
 deer
```

The output categorical array, `B`, has the same contents as the input categorical array, `A`.

List the categories of the categorical array, `B`.

# reordercats

---

```
bcats = categories(B)

bcats =

 'ant'
 'bear'
 'cat'
 'deer'
 'eagle'
 'frog'
```

The categories of B are in alphabetical order.

## Reorder Categories in Nonordinal Categorical Array

Create a categorical array containing the color of various items.

```
A = categorical({'red'; 'green'; 'blue'; 'red'; 'green'; 'red'; 'blue'; 'blue'})
```

```
A =

 red
 green
 blue
 red
 green
 red
 blue
 blue
```

A is an 8-by-1 categorical array.

Display the categories of A.

```
categories(A)
```

```
ans =

 'blue'
```

```
'green'
'red'
```

The categories of A are in alphabetical order and have no mathematical meaning.

Reorder the categories to match the order commonly used for colors.

```
B = reordercats(A,{'red','green','blue'})
```

```
B =
```

```
red
green
blue
red
green
red
blue
blue
```

B contains the same values as A.

Display the categories of B.

```
categories(B)
```

```
ans =
```

```
'red'
'green'
'blue'
```

B is not ordinal and the order of the categories has no mathematical meaning. Although the categories appear in the order of the color spectrum, relational operations, such as greater than and less than, have no meaning.

## Reorder Categories in Ordinal Categorical Array

Create an ordinal categorical array, `A`, containing modes of transportation. Order the categories based on the average price of travel.

```
A = categorical({'plane'; 'car'; 'train'; 'car'; 'plane'; 'car'}, ...
 {'car', 'train', 'plane'}, 'Ordinal', true)
```

```
A =
```

```
 plane
 car
 train
 car
 plane
 car
```

`A` is a 6-by-1 ordinal categorical array.

Display the categories of `A`.

```
categories(A)
```

```
ans =
```

```
 'car'
 'train'
 'plane'
```

Since `A` is ordinal, `car < train < plane`.

Reorder the categories to reflect a decrease in the cost of train travel.

```
B = reordercats(A, {'train', 'car', 'plane'})
```

```
B =
```

```
 plane
```



```
car
train
car
plane
car
```

B contains the same values as A.

Display the categories of B.

```
categories(B)
```

```
ans =
 'train'
 'car'
 'plane'
```

The mathematical ordering of the categories is now `train < car < plane`. The results from relational operations, `min`, and `max` reflect the new category ordering.

## Tips

- To convert the categorical array, B, to an ordinal categorical array, use `B = categorical(B, 'Ordinal', true)`. Furthermore, you can specify the order of the categories with `B = categorical(B, valueset, 'Ordinal', true)` where the order of the values in `valueset` defines the category order.

## See Also

`categories` | `addcats` | `removecats` | `iscategory` | `mergocats` | `renamecats`

# FTP.rename

---

<b>Purpose</b>	Rename file on FTP server
<b>Syntax</b>	<code>rename(ftpobj,oldname,newname)</code>
<b>Description</b>	<code>rename(ftpobj,oldname,newname)</code> changes the name of the file <code>oldname</code> to <code>newname</code> in the current folder on an FTP server.
<b>Input Arguments</b>	<p><b>ftpobj</b> FTP object created by <code>ftp</code>.</p> <p><b>oldname</b> String enclosed in single quotation marks that specifies the original name of the file.</p> <p><b>newname</b> String enclosed in single quotation marks that specifies a new name for the file.</p>
<b>Examples</b>	<p>Suppose that hypothetical FTP server <code>ftp.testsite.com</code> contains a file named <code>testfile.m</code>. Rename the file to <code>final.m</code>:</p> <pre>test = ftp('ftp.testsite.com'); rename(test, 'testfile.m', 'final.m'); close(test);</pre>
<b>See Also</b>	<code>delete</code>   <code>dir</code>   <code>ftp</code>   <code>mget</code>   <code>mput</code>

<b>Purpose</b>	Replicate and tile array
<b>Syntax</b>	<pre>B = repmat(A,n) B = repmat(A,sz1,sz2,...,szN) B = repmat(A,sz)</pre>
<b>Description</b>	<p><code>B = repmat(A,n)</code> returns an n-by-n tiling of A. The size of B is <code>size(A) * n</code></p> <p><code>B = repmat(A,sz1,sz2,...,szN)</code> specifies a list of scalars, <code>sz1,sz2,...,szN</code>, to describe an N-D tiling of A. The size of B is <code>[size(A,1)*sz1, size(A,2)*sz2,...,size(A,n)*szN]</code>. For example, <code>repmat([1 2; 3 4],2,3)</code> returns a 4-by-6 matrix.</p> <p><code>B = repmat(A,sz)</code> specifies a row vector, <code>sz</code>, instead of a list of scalars, to describe the tiling of A. This syntax returns the same output as the previous syntax. For example, <code>repmat([1 2; 3 4],[2 3])</code> returns the same result as <code>repmat([1 2; 3 4],2,3)</code>.</p>
<b>Input Arguments</b>	<p><b>A - Input array</b> scalar   vector   array   cell array   table   structure   object</p> <p>Input array, specified as a scalar, vector, array, cell array, table, structure, or object.</p> <p><b>Example: 1</b></p> <p><b>Example:</b> <code>[1 2 3]</code></p> <p><b>Example:</b> <code>[1 2; 3 4]</code></p> <p><b>Example:</b> <code>{'foo',[20 30 40]}</code></p> <p><b>Example:</b> <code>table(rand(5,1),rand(5,1))</code></p> <p><b>Example:</b> <code>struct('Age',25,'Weight',110)</code></p> <p><b>n - Uniform tiling factor</b> scalar</p>

# repmat

Uniform tiling factor, specified as a scalar value. The `n` argument creates an `n`-by-`n` tiling of `A`. If `n` is 0 or negative, the result is an empty array.

**Example:** 3

## **sz1, sz2, ..., szN - Tiling factors for each dimension of A**

two or more scalars

Tiling factors for each dimension of `A`, specified as two or more scalar values. If any tiling factor is 0 or negative, the result is an empty array.

**Example:** 2, 3

**Example:** 2, 3, 4, 2

## **sz - Tiling vector**

row vector

Tiling vector, specified as a row vector. If any value in `sz` is 0 or negative, the result is an empty array.

**Example:** [2 3]

**Example:** [2 3 4 2]

## Tips

- You can use `bsxfun` to tile arrays and perform a binary operation in a single pass. In some cases, `bsxfun` provides a simpler and more memory efficient solution. For example, to add the vectors, `x=1:5` and `y=(1:10)'` to produce a 10-by-5 array, use `bsxfun(@plus,x,y)` instead of `repmat(x,10,1) + repmat(y,1,5)`.
- You can use other functions to get the same result as `repmat` when `A` is a scalar of a certain type.

repmat Syntax	Equivalent Alternative
<code>repmat(NaN,m,n)</code>	<code>NaN(m,n)</code>
<code>repmat(single(inf),m,n)</code>	<code>inf(m,n,'single')</code>
<code>repmat(int8(0),m,n)</code>	<code>zeros(m,n,'int8')</code>

repmat Syntax	Equivalent Alternative
<code>repmat(uint32(1),m,n)</code>	<code>ones(m,n,'uint32')</code>
<code>repmat(eps,m,n)</code>	<code>eps(ones(m,n))</code>

## Examples

### Replicate and Tile a Matrix

Create a diagonal matrix.

```
A = diag([100 200 300])
```

A =

```

100 0 0
 0 200 0
 0 0 300
```

Create a 2-by-2 tiling of A.

```
B = repmat(A,2)
```

B =

```

100 0 0 100 0 0
 0 200 0 0 200 0
 0 0 300 0 0 300
100 0 0 100 0 0
 0 200 0 0 200 0
 0 0 300 0 0 300
```

### Replicate and Tile an N-D Array

Create a 2-by-2-by-2 array.

```
A = zeros(2,2,2);
A(:,:,1) = diag([10 20]);
A(:,:,2) = diag([55 99]);
A
```

# repmat

---

$A(:,:,1) =$

10	0
0	20

$A(:,:,2) =$

55	0
0	99

Create a 3-by-3 tiling of A.

$B = \text{repmat}(A,3)$

$B(:,:,1) =$

10	0	10	0	10	0
0	20	0	20	0	20
10	0	10	0	10	0
0	20	0	20	0	20
10	0	10	0	10	0
0	20	0	20	0	20

$B(:,:,2) =$

55	0	55	0	55	0
0	99	0	99	0	99
55	0	55	0	55	0
0	99	0	99	0	99
55	0	55	0	55	0
0	99	0	99	0	99

## Vertical Stack of Row Vectors

Create a row vector.

```
A = 1:4
```

```
A =
```

```
 1 2 3 4
```

Create a vertical stack of four copies of A.

```
B = repmat(A,4,1)
```

```
B =
```

```
 1 2 3 4
 1 2 3 4
 1 2 3 4
 1 2 3 4
```

B contains 4 copies of A in the first dimension and 1 copy in the second dimension. This result is equivalent to `B = repmat(A,[4 1])`.

### Horizontal Stack of Column Vectors

Create a column vector.

```
A = (1:3)'
```

```
A =
```

```
 1
 2
 3
```

Create a horizontal stack of four copies of A.

```
B = repmat(A,1,4)
```

```
B =
```

```
 1 1 1 1
```

# repmat

---

```
 2 2 2 2
 3 3 3 3
```

B contains 1 copy of A in the first dimension and 4 copies in the second dimension. This result is equivalent to `B = repmat(A,[1 4])`.

## Replicate and Tile a Complex Scalar Value

Define a complex scalar value.

```
A = 5+1i;
```

Create a 3-by-2 tiling of A.

```
B = repmat(A,[3 2])
```

```
B =
```

```
 5.0000 + 1.0000i 5.0000 + 1.0000i
 5.0000 + 1.0000i 5.0000 + 1.0000i
 5.0000 + 1.0000i 5.0000 + 1.0000i
```

B contains 3 copies of A in the first dimension and 2 copies in the second dimension. This result is equivalent to `B = repmat(A,3,2)`.

## Replicate and Tile a Cell Array

Create a cell array containing a string and numeric values.

```
A = {'Values'; 10; 105}
```

```
A =
```

```
 'Values'
 [10]
 [105]
```

Create a 3-by-2 tiling of A.

```
B = repmat(A,[3 2])
```



B =

```
'Values' 'Values'
[10] [10]
[105] [105]
'Values' 'Values'
[10] [10]
[105] [105]
'Values' 'Values'
[10] [10]
[105] [105]
```

B contains 3 copies of A in the first dimension and 2 copies in the second dimension. This result is equivalent to `B = repmat(A,3,2)`.

## See Also

[bsxfun](#) | [Inf](#) | [NaN](#) | [ones](#) | [zeros](#) | [reshape](#) | [meshgrid](#) | [ndgrid](#)

# resample (tscollection)

---

**Purpose** Select or interpolate data in `tscollection` using new time vector

**Syntax**

```
tsc = resample(tsc,Time)
tsc = resample(tsc,Time,interp_method)
tsc = resample(tsc,Time,interp_method,code)
```

**Description** `tsc = resample(tsc,Time)` resamples the `tscollection` object `tsc` on the new `Time` vector. When `tsc` uses date strings and `Time` is numeric, `Time` is treated as numerical specified relative to the `tsc.TimeInfo.StartDate` property and in the same units that `tsc` uses. The `resample` method uses the default interpolation method for each time series member.

`tsc = resample(tsc,Time,interp_method)` resamples the `tscollection` object `tsc` using the interpolation method given by the string `interp_method`. Valid interpolation methods include 'linear' and 'zoh' (zero-order hold).

`tsc = resample(tsc,Time,interp_method,code)` resamples the `tscollection` object `tsc` using the interpolation method given by the string `interp_method`. The integer `code` is a user-defined quality code for resampling, applied to all samples.

**Examples** The following example shows how to resample a `tscollection` that consists of two `timeseries` members.

**1** Create two `timeseries` objects.

```
ts1=timeseries([1.1 2.9 3.7 4.0 3.0],1:5,'name','acceleration');
ts2=timeseries([3.2 4.2 6.2 8.5 1.1],1:5,'name','speed');
```

**2** Create a `tscollection` `tsc`.

```
tsc=tscollection({ts1 ts2});
```

The time vector of the collection `tsc` is `[1:5]`, which is the same as for `ts1` and `ts2` (individually).

- 3** Get the interpolation method for acceleration by typing

```
tsc.acceleration
```

MATLAB responds with

```
Time Series Object: acceleration
```

```
Time vector characteristics
```

```
Length 5
Start time 1 seconds
End time 5 seconds
```

```
Data characteristics
```

```
Interpolation method linear
Size [1 1 5]
Data type double
```

- 4** Set the interpolation method for speed to zero-order hold by typing

```
setinterpmethod(tsc.speed, 'zoh')
```

MATLAB responds with

```
Time Series Object: acceleration
```

```
Time vector characteristics
```

```
Length 5
Start time 1 seconds
End time 5 seconds
```

# resample (tscollection)

---

Data characteristics

Interpolation method	zoh
Size	[1 1 5]
Data type	double

- 5 Resample the time-series collection `tsc` by individually resampling each time-series member of the collection and using its interpolation method.

```
res_tsc=resample(tsc,[1 1.5 3.5 4.5 4.9])
```

## See Also

`getinterpmethod` | `setinterpmethod` | `tscollection`

**Purpose** Reset graphics object properties to their defaults

**Syntax** `reset(h)`

**Description** `reset(h)` resets all properties on the object identified by `h` to their default values. Properties that do not have default values are not affected.

To obtain the default value of a property defined on the root level, use this statement.

```
get(0, 'DefaultFigureColor')
```

If `h` is a figure, the MATLAB software does not reset `Position`, `Units`, `WindowStyle`, or `PaperUnits`. If `h` is an axes, MATLAB does not reset `Position` and `Units`.

**Examples** `reset(gca)` resets the properties of the current axes.

`reset(gcf)` resets the properties of the current figure.

**See Also** `cla` | `clf` | `gca` | `gcf` | `hold`

# reset (RandStream)

---

**Purpose** Reset random number stream

**Class** RandStream

**Syntax**  
`reset(s)`  
`reset(s,seed)`

**Description** `reset(s)` resets the generator for the random stream, `s`, to the internal state corresponding to its seed. This is similar to clearing `s` and recreating it using `RandStream(Type,...)`, except that `reset` does not set the stream's `NormalTransform`, `Antithetic`, and `FullPrecision` properties to their original values.

`reset(s,seed)` resets the generator for the random stream, `s`, to the internal state corresponding to `seed` (the seed value), and it updates the `seed` property of `s`. The value of `seed` must be an integer between 0 and  $2^{32} - 1$ . Resetting a stream's seed can invalidate independence with other streams.

---

**Note** Resetting a stream should be used primarily for reproducing results.

---

## Examples

### Example 1

Reset a random number stream to its initial state. This does not create a random number stream, it simply resets the stream:

```
stream = RandStream('twister','Seed',0)
```

```
stream =
```

```
mt19937ar random stream
 Seed: 0
 NormalTransform: Ziggurat
```

```
reset(stream);
stream.Seed
```

```
ans =
```

```
0
```

## Example 2

Reset a random number stream using a specific seed:

```
stream = RandStream('twister','Seed',0)
```

```
stream =
```

```
mt19937ar random stream
 Seed: 0
 NormalTransform: Ziggurat
```

```
reset(stream,1);
stream.Seed
```

```
ans =
```

```
1
```

## See Also

[RandStream](#) | [RandStream.getGlobalStream](#)

# reshape

---

**Purpose** Reshape array

**Syntax**

```
B = reshape(A,m,n)
B = reshape(A,[m n])
B = reshape(A,m,n,p,...)
B = reshape(A,[m n p ...])
B = reshape(A,...,[],...)
```

**Description** `B = reshape(A,m,n)` or `B = reshape(A,[m n])` returns the m-by-n matrix B whose elements are taken column-wise from A. An error results if A does not have m\*n elements.

`B = reshape(A,m,n,p,...)` or `B = reshape(A,[m n p ...])` returns an n-dimensional array with the same elements as A but reshaped to have the size m-by-n-by-p-by-.... The product of the specified dimensions, m\*n\*p\*..., must be the same as `numel(A)`.

`B = reshape(A,...,[],...)` calculates the length of the dimension represented by the placeholder [], such that the product of the dimensions equals `numel(A)`. The value of `numel(A)` must be evenly divisible by the product of the specified dimensions. You can use only one occurrence of [].

**Examples** Reshape a 3-by-4 matrix into a 2-by-6 matrix.

```
A =
 1 4 7 10
 2 5 8 11
 3 6 9 12

B = reshape(A,2,6)

B =
 1 3 5 7 9 11
 2 4 6 8 10 12

B = reshape(A,2,[])

B =
```



```
1 3 5 7 9 11
2 4 6 8 10 12
```

## See Also

`shiftdim` | `squeeze` | `circshift` | `permute` | `repmat` | `colon` (:)

# residue

---

**Purpose** Convert between partial fraction expansion and polynomial coefficients

**Syntax**  
[r,p,k] = residue(b,a)  
[b,a] = residue(r,p,k)

**Description** The residue function converts a quotient of polynomials to pole-residue representation, and back again.

[r,p,k] = residue(b,a) finds the residues, poles, and direct term of a partial fraction expansion of the ratio of two polynomials,  $b(s)$  and  $a(s)$ , of the form

$$\frac{b(s)}{a(s)} = \frac{b_1s^m + b_2s^{m-1} + b_3s^{m-2} + \dots + b_{m+1}}{a_1s^n + a_2s^{n-1} + a_3s^{n-2} + \dots + a_{n+1}}$$

where  $b_j$  and  $a_j$  are the  $j$ th elements of the input vectors  $b$  and  $a$ .

[b,a] = residue(r,p,k) converts the partial fraction expansion back to the polynomials with coefficients in  $b$  and  $a$ .

**Definitions** If there are no multiple roots, then

$$\frac{b(s)}{a(s)} = \frac{r_1}{s-p_1} + \frac{r_2}{s-p_2} + \dots + \frac{r_n}{s-p_n} + k(s)$$

The number of poles  $n$  is

$$n = \text{length}(a) - 1 = \text{length}(r) = \text{length}(p)$$

The direct term coefficient vector is empty if  $\text{length}(b) < \text{length}(a)$ ; otherwise

$$\text{length}(k) = \text{length}(b) - \text{length}(a) + 1$$

If  $p(j) = \dots = p(j+m-1)$  is a pole of multiplicity  $m$ , then the expansion includes terms of the form

$$\frac{r_j}{s-p_j} + \frac{r_{j+1}}{(s-p_j)^2} + \dots + \frac{r_{j+m-1}}{(s-p_j)^m}$$

## Arguments

b, a	Vectors that specify the coefficients of the polynomials in descending powers of $s$
r	Column vector of residues
p	Column vector of poles
k	Row vector of direct terms

## Algorithms

It first obtains the poles with `roots`. Next, if the fraction is nonproper, the direct term `k` is found using `deconv`, which performs polynomial long division. Finally, the residues are determined by evaluating the polynomial with individual roots removed. For repeated roots, `resid2` computes the residues at the repeated root locations.

## Limitations

Numerically, the partial fraction expansion of a ratio of polynomials represents an ill-posed problem. If the denominator polynomial,  $a(s)$ , is near a polynomial with multiple roots, then small changes in the data, including roundoff errors, can make arbitrarily large changes in the resulting poles and residues. Problem formulations making use of state-space or zero-pole representations are preferable.

## Examples

If the ratio of two polynomials is expressed as

$$\frac{b(s)}{a(s)} = \frac{5s^3 + 3s^2 - 2s + 7}{-4s^3 + 8s + 3}$$

then

$$\begin{aligned} \mathbf{b} &= [ 5 \ 3 \ -2 \ 7 ] \\ \mathbf{a} &= [ -4 \ 0 \ 8 \ 3 ] \end{aligned}$$

and you can calculate the partial fraction expansion as

# residue

---

```
[r, p, k] = residue(b,a)
```

```
r =
 -1.4167
 -0.6653
 1.3320
```

```
p =
 1.5737
 -1.1644
 -0.4093
```

```
k =
 -1.2500
```

Now, convert the partial fraction expansion back to polynomial coefficients.

```
[b,a] = residue(r,p,k)
```

```
b =
 -1.2500 -0.7500 0.5000 -1.7500
```

```
a =
 1.0000 -0.0000 -2.0000 -0.7500
```

The result can be expressed as

$$\frac{b(s)}{a(s)} = \frac{-1.25s^3 - 0.75s^2 + 0.50s - 1.75}{s^3 - 2.00s - 0.75}.$$

Note that the result is normalized for the leading coefficient in the denominator.

## References

[1] Oppenheim, A.V. and R.W. Schaffer, *Digital Signal Processing*, Prentice-Hall, 1975, p. 56.

**See Also**      `deconv` | `poly` | `roots`

# restoredefaultpath

---

<b>Purpose</b>	Restore default search path
<b>Alternatives</b>	As an alternative to the <code>restoredefaultpath</code> function, use the Set Path dialog box.
<b>Syntax</b>	<code>restoredefaultpath</code> <code>restoredefaultpath; matlabrc</code>
<b>Description</b>	<p><code>restoredefaultpath</code> sets the search path to include only folders for MathWorks installed products. Use <code>restoredefaultpath</code> when you are having problems with the search path.</p> <p><code>restoredefaultpath; matlabrc</code> sets the search path to include only folders for MathWorks installed products and corrects search path problems encountered during startup.</p> <p>MATLAB does not support issuing <code>restoredefaultpath</code> from a UNC path name. Doing so might result in MATLAB being unable to find files on the search path. If you do issue <code>restoredefaultpath</code> from a UNC path name, restore the expected behavior by changing the current folder to an absolute path, and then reissuing <code>restoredefaultpath</code>.</p>
<b>See Also</b>	<code>addpath</code>   <code>genpath</code>   <code>matlabrc</code>   <code>rmpath</code>   <code>savepath</code>
<b>How To</b>	<ul style="list-style-type: none"><li>• “Path Unsuccessfully Set at Startup”</li><li>• “What Is the MATLAB Search Path?”</li></ul>

**Purpose** Reissue error

---

**Note** As of version 7.5, MATLAB supports error handling that is based on the `MException` class. Calling `rethrow` with a structure argument, as described on this page, is now replaced by calling `rethrow` with an `MException` object, as described on the reference page for `rethrow(MException)`. `rethrow` called with a structure input will be removed in a future version.

---

**Syntax** `rethrow(errorStruct)`

**Description** `rethrow(errorStruct)` reissues the error specified by `errorStruct`. The currently running function terminates and control returns to the keyboard (or to any enclosing catch block). The `errorStruct` argument must be a MATLAB structure containing at least the message and identifier fields:

Fieldname	Description
<code>message</code>	Text of the error message
<code>identifier</code>	Message identifier of the error message
<code>stack</code>	Information about the error from the program stack

See "Message Identifiers" in the MATLAB documentation for more information on the syntax and usage of message identifiers.

**Tips** The `errorStruct` input can contain the field `stack`, identical in format to the output of the `dbstack` command. If the `stack` field is present, the stack of the rethrown error will be set to that value. Otherwise, the stack will be set to the line at which the `rethrow` occurs.

# rethrow

---

## Examples

rethrow is usually used in conjunction with `try`, `catch` statements to reissue an error from a `catch` block after performing catch-related operations. For example,

```
try
 do_something
catch
 do_cleanup
 rethrow(previous_error)
end
```

## See Also

```
rethrow(MException) | throw(MException) |
throwAsCaller(MException) | assert | error | MException |
try, catch
```



**Purpose** Reissue existing exception

**Syntax** `rethrow(exception)`

**Description** `rethrow(exception)` forces an exception (i.e., error report) to be reissued by MATLAB after the error reporting process has been temporarily suspended to diagnose or remedy the problem. MATLAB typically responds to errors by terminating the currently running program. Errors occurring within a try block, however, bypass this mechanism and transfer control of the program to error handling code in the catch block instead. This enables you to write your own error handling procedures for parts of your program that require them.

The *exception* input is a scalar object of the MException class that contains information about the cause and location of the error.

The code segment below shows the format of a typical try/catch statement.

try	try block
program-code	
program-code	
:	V
catch exception	catch block
error-handling code	
:	
rethrow(exception)	V
end	

An error detected within the try block causes MATLAB to enter the corresponding catch block. The error record constructed by MATLAB in the process of reporting this error passes to the try, catch command in the statement

```
catch exception
```

Error handling code within the catch block uses the information in the error record to address the problem in some predefined manner. The

## rethrow (MException)

---

catch block shown here ends with a `rethrow` statement which throws the exception returned in the catch statement, and then terminates the function:

```
rethrow(exception)
```

The most significant difference between `rethrow` and other MATLAB functions that throw exceptions is in how `rethrow` handles a piece of the exception record called the *stack*. The stack keeps a record of where the error occurred and what functions were called in the process. It is a struct array composed of the following fields, where each element of the array represents an exception:

Fields of the Exception Stack	Description
<code>line</code>	Line number from which the exception was thrown.
<code>name</code>	Name of the function being executed at the time.
<code>file</code>	Name of the file containing that function.

Functions such as `error`, `assert`, or `throw`, create the stack with the location from which they were executed. Calling `rethrow`, however, preserves information from the original exception. In doing so, `rethrow` enables you to retrace the path taken to the source of the error.

### Tips

There are four ways to throw an exception in MATLAB (see the list below). Use the first of these when testing the outcome of some action for failure and reporting the failure to MATLAB. Use one of the remaining techniques to throw an existing exception.

- Test the result of some action taken by your program. If the result is found to be incorrect or unexpected, compose an appropriate message and message identifier, and pass these to MATLAB using the `error` function.

- Reissue the original exception by throwing the initial error record unmodified. Use the `MException rethrow` method to do this.
- Collect additional information on the cause of the error, store it in a new or modified error record, and issue a new exception based on that record. Use the `MException addCause` and `throw` methods to do this.
- Make it appear that the error originated in the caller of the currently running function. Use the `MException throwAsCaller` method to do this.

`rethrow` can only issue a previously caught exception. Calling `rethrow` on an exception that was not previously thrown is an error.

## Examples

This example shows the difference between using `throw` and `rethrow` at the end of a catch block. The `combineArrays` function vertically concatenates arrays A and B. When the two arrays have rows of unequal length, the function throws an error.

The first time you run the function, comment out the `rethrow` command at the end of the catch block so that the function calls `throw` instead:

```
function C = combineArrays(A, B)
try
 catAlongDim1(A, B); % Line 3
catch exception
 throw(exception) % Line 5
 % rethrow(exception) % Line 6
end

function catAlongDim1(V1, V2)
 C = cat(1, V1, V2); % Line 10
```

When MATLAB throws the exception, it reports an error on line 5 which is the line that calls `throw`. In some cases, that might be what you want but, in this case, it does not show the true source of the error.

```
A = 4:3:19; B = 3:4:19;
combineArrays(A, B)
```

## rethrow (MException)

---

```
Error using combineArrays (line 5)
CAT arguments dimensions are not consistent.
```

Make the following changes to `combineArrays.m` so that you use `rethrow` instead:

```
% throw(exception) % Line 5
rethrow(exception) % Line 6
```

Run the function again. This time, line 10 is the first line reported which is where the MATLAB concatenation function `cat` was called and the exception originated. The next error reported is on line 3 which is where the call to `catAlongDim1` was called:

```
combineArrays(A, B)
```

```
Error using cat
CAT arguments dimensions are not consistent.
```

```
Error in combineArrays>catAlongDim1 (line 10)
 C = cat(1, V1, V2); % Line 10
```

```
Error in combineArrays (line 3)
 catAlongDim1(A, B); % Line 3
```

### See Also

```
throw(MException) | throwAsCaller(MException)
| last(MException) | getReport(MException) |
addCause(MException) | assert | error | MException |
try, catch
```

**Purpose** Return to invoking function

**Syntax** return

**Description** return causes a normal return to the invoking function or to the keyboard. It also terminates keyboard mode.

**Examples** This determinant function uses return to handle the special case of an empty matrix:

```
function d = det(A)
%DET det(A) is the determinant of A.
if isempty(A)
 d = 1;
 return
else
 ...
end
```

**See Also** while | keyboard | for | error | end | disp | continue | break  
| if | switch

# Tiff.rewriteDirectory

---

**Purpose** Write modified metadata to existing IFD

**Syntax** `tiffobj.rewriteDirectory()`

**Description** `tiffobj.rewriteDirectory()` writes modified metadata (tag) data to an existing directory. Use this tag when you want to change the value of a tag in an existing image file directory.

## **Examples** **Modify Value of Tag**

Write a sample TIFF file, `mytif.tif`. Create a TIFF object associated with this file.

```
imdata = peaks(256);
imwrite(imdata, 'mytif.tif');
t = Tiff('mytif.tif', 'r+');
```

Modify the value of a tag.

```
t.setTag('Software', 'MATLAB');
t.rewriteDirectory();
t.close();
```

## **References**

This method corresponds to the `TIFFRewriteDirectory` function in the LibTIFF C API. To use this method, you must be familiar with the TIFF specification and technical notes. View this documentation at [LibTIFF - TIFF Library and Utilities](#).

**See Also** `Tiff.writeDirectory`

**Tutorials**

- “Exporting Image Data and Metadata to TIFF Files”
- “Reading Image Data and Metadata from TIFF Files”

**Purpose** Convert RGB colormap to HSV colormap

**Syntax**

```
cmap = rgb2hsv(M)
hsv_image = rgb2hsv(rgb_image)
```

**Description** `cmap = rgb2hsv(M)` converts an RGB colormap `M` to an HSV colormap `cmap`. Both colormaps are  $m$ -by-3 matrices. The elements of both colormaps are in the range 0 to 1.

The columns of the input matrix `M` represent intensities of red, green, and blue, respectively. The columns of the output matrix `cmap` represent hue, saturation, and value, respectively.

`hsv_image = rgb2hsv(rgb_image)` converts the RGB image to the equivalent HSV image. RGB is an  $m$ -by- $n$ -by-3 image array whose three planes contain the red, green, and blue components for the image. HSV is returned as an  $m$ -by- $n$ -by-3 image array whose three planes contain the hue, saturation, and value components for the image.

**See Also** [brighten](#) | [colormap](#) | [hsv2rgb](#) | [rgbplot](#)

# rgb2ind

---

**Purpose** Convert RGB image to indexed image

**Syntax**

```
[X,map] = rgb2ind(RGB,n)
X = rgb2ind(RGB, map)
[X,map] = rgb2ind(RGB, tol)
[___] = rgb2ind(___,dither_option)
```

**Description**

`[X,map] = rgb2ind(RGB,n)` converts the RGB image to an indexed image `X` using minimum variance quantization and dithering. `map` contains at most `n` colors. `n` must be less than or equal to 65,536.

`X = rgb2ind(RGB, map)` converts the RGB image to an indexed image `X` with colormap `map` using the inverse colormap algorithm and dithering. `size(map,1)` must be less than or equal to 65,536.

`[X,map] = rgb2ind(RGB, tol)` converts the RGB image to an indexed image `X` using uniform quantization and dithering. `map` contains at most  $(\text{floor}(1/\text{tol})+1)^3$  colors. `tol` must be between 0.0 and 1.0.

`[ ___ ] = rgb2ind( ___,dither_option)` enables or disables dithering. `dither_option` is a string that can have one of these values.

'dither' (default)	Dithers, if necessary, to achieve better color resolution at the expense of spatial resolution
'nodither'	Maps each color in the original image to the closest color in the new map. No dithering is performed.

---

**Note** The values in the resultant image `X` are indexes into the colormap `map` and should not be used in mathematical processing, such as filtering operations.

---

**Class Support**

The input image can be of class `uint8`, `uint16`, `single`, or `double`. If the length of `map` is less than or equal to 256, the output image is of class `uint8`. Otherwise, the output image is of class `uint16`.



The value 0 in the output array  $X$  corresponds to the first color in the colormap.

## Tips

- If you specify `tol`, `rgb2ind` uses uniform quantization to convert the image. This method involves cutting the RGB color cube into smaller cubes of length `tol`.
- If you specify `n`, `rgb2ind` uses minimum variance quantization. This method involves cutting the RGB color cube into smaller boxes (not necessarily cubes) of different sizes, depending on how the colors are distributed in the image. If the input image actually uses fewer colors than the number you specify, the output colormap is also smaller.
- If you specify `map`, `rgb2ind` uses colormap mapping, which involves finding the colors in `map` that best match the colors in the RGB image.

## Algorithms

- **Uniform Quantization** — Uniform quantization cuts the RGB color cube into smaller cubes of length `tol`. For example, if you specify a `tol` of 0.1, the edges of the cubes are one-tenth the length of the RGB cube. The total number of small cubes is:

$$n = (\text{floor}(1/\text{tol})+1)^3$$

Each cube represents a single color in the output image. Therefore, the maximum length of the colormap is `n`. `rgb2ind` removes any colors that don't appear in the input image, so the actual colormap can be much smaller than `n`.

- **Minimum Variance Quantization** — Minimum variance quantization cuts the RGB color cube into smaller boxes (not necessarily cubes) of different sizes, depending on how the colors are distributed in the image. If the input image actually uses fewer colors than the number specified, the output colormap is also smaller.
- **Inverse Colormap** — The inverse colormap algorithm quantizes the specified colormap into 32 distinct levels per color component. Then, for each pixel in the input image, the closest color in the quantized colormap is found.

# rgb2ind

---

## Examples

Read and display a truecolor uint8 JPEG image of a nebula.

```
RGB = imread('ngc6543a.jpg');
figure('Name','RGB Image')
imagesc(RGB)
axis image
zoom(4)
```

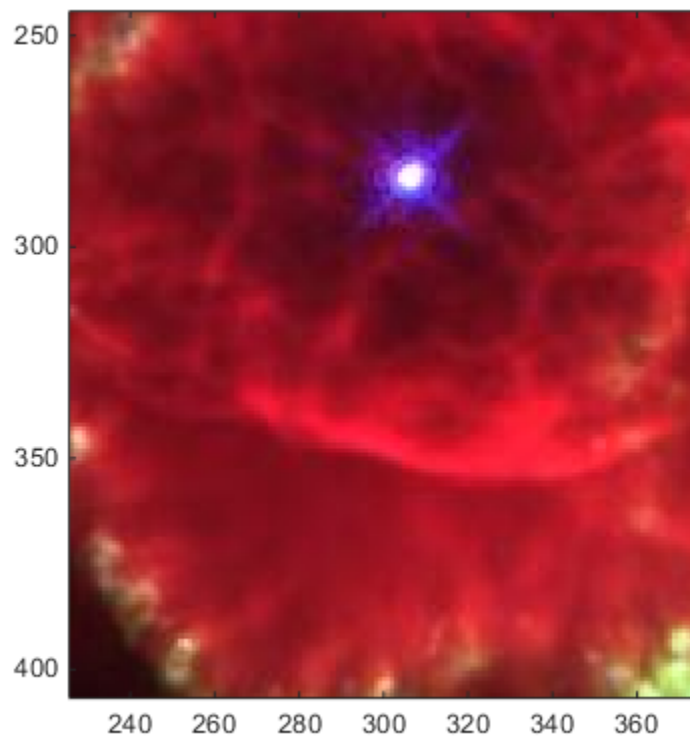

Convert RGB to an indexed image with 32 colors

```
[IND,map] = rgb2ind(IMG,32);
figure('Name','Indexed image with 32 Colors')
imagesc(IND)
colormap(map)
axis image
zoom(4)
```

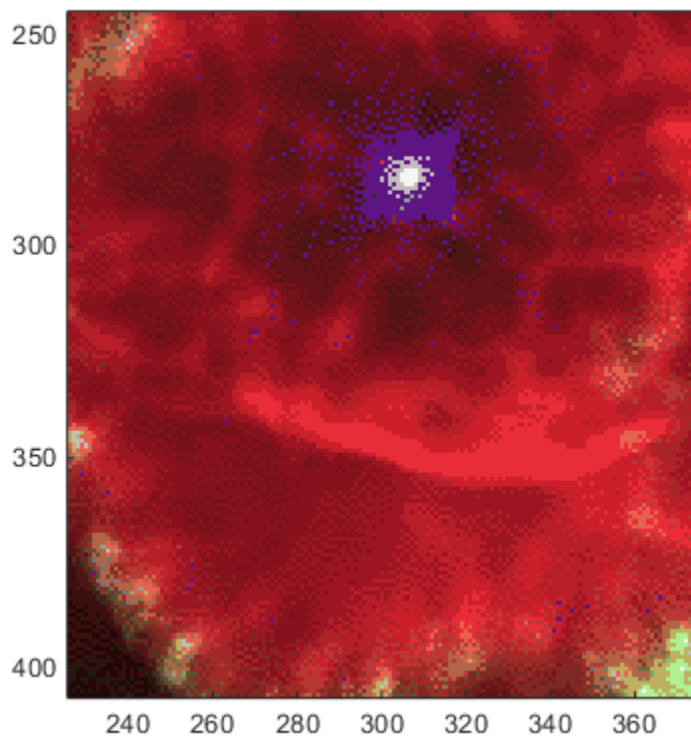

## References

[1] Spencer W. Thomas, "Efficient Inverse Color Map Computation", *Graphics Gems II*, (ed. James Arvo), Academic Press: Boston. 1991. (includes source code)

## See Also

`cmunique` | `dither` | `imapprox` | `ind2rgb`

## Purpose

Plot colormap

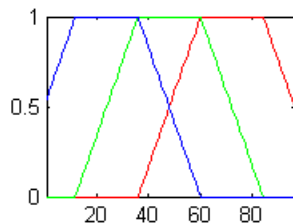

## Syntax

`rgbplot(cmap)`

## Description

`rgbplot(cmap)` plots the three columns of `cmap`, where `cmap` is an  $m$ -by-3 colormap matrix. `rgbplot` draws the first column in red, the second in green, and the third in blue.

## Examples

### Copper Colormap

Plot the RGB values of the copper colormap.

```
rgbplot(copper)
```

# rgbplot

---

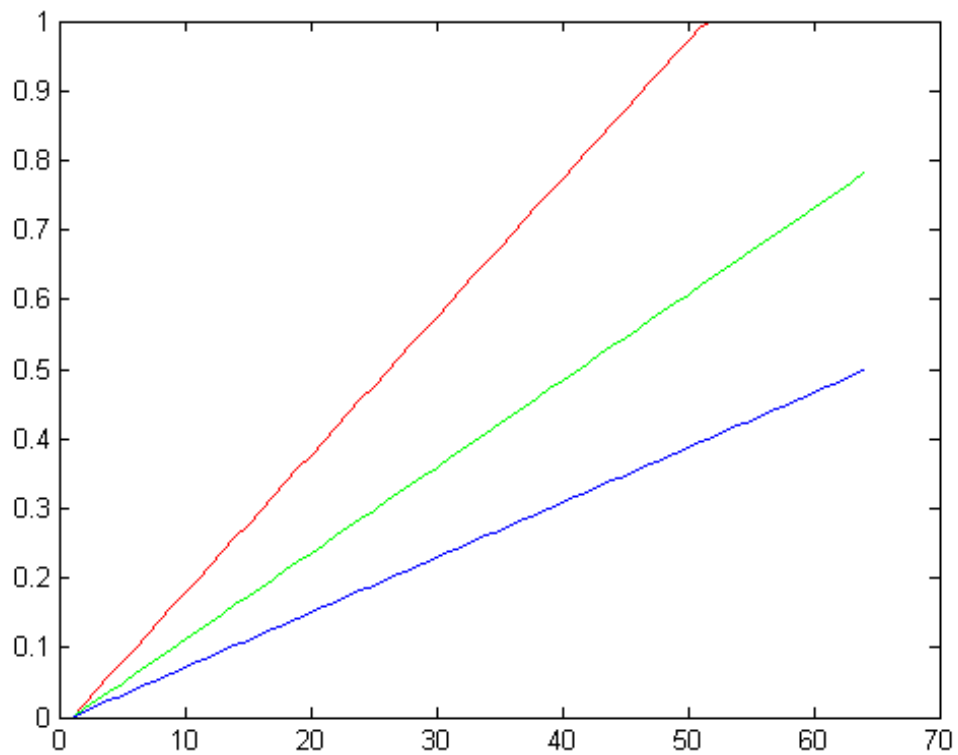

## Summer Colormap

Plot the RGB values of the summer colormap.

```
rgbplot(summer)
```

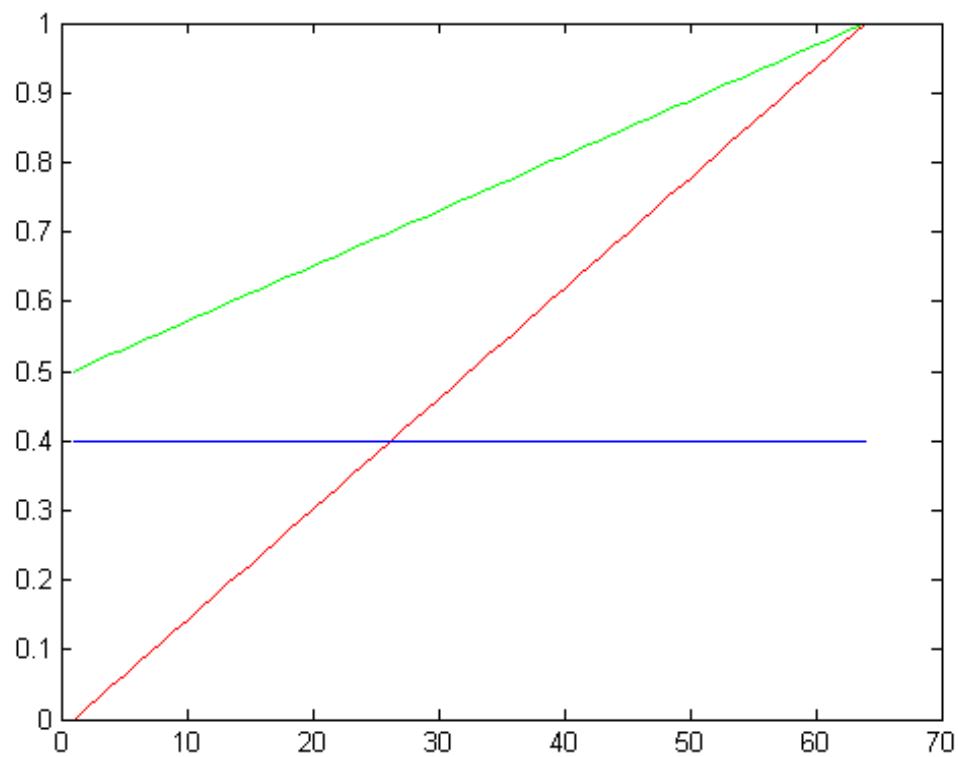

**See Also** `colormap`

# ribbon

---

## Purpose

Ribbon plot



## Syntax

```
ribbon(Y)
ribbon(X,Y)
ribbon(X,Y,width)
ribbon(axes_handle,...)
h = ribbon(...)
```

## Description

`ribbon(Y)` plots the columns of `Y` as three-dimensional ribbons of uniform width using `X = 1:size(Y,1)`. Ribbons advance along the  $x$ -axis centered on tick marks at unit intervals, three-quarters of a unit in width. Ribbon maps values in `X` to colors in `colormap` linearly. To change ribbon colors in the graph, change the `colormap`.

`ribbon(X,Y)` plots three dimensional ribbons for data in `Y`, centered at locations specified in `X`. `X` and `Y` are vectors or matrices of the same size. Additionally, `X` can be a row or a column vector, and `Y` a matrix with `length(X)` rows. When `Y` is a matrix, `ribbon` plots each column in `Y` as a ribbon at the corresponding `X` location.

`ribbon(X,Y,width)` specifies the width of the ribbons. The default is 0.75. If `width = 1`, the ribbons touch, leaving no space between them when viewed down the  $z$ -axis. If `width > 1`, ribbons overlap and can intersect.

`ribbon(axes_handle,...)` plots into the axes with handle `axes_handle` instead of the current axes (`gca`).

`h = ribbon(...)` returns a vector of handles to surface graphics objects. `ribbon` returns one handle per strip.

## Examples

Create a ribbon plot of the peaks function.

```
[x,y] = meshgrid(-3:.5:3,-3:.1:3);
z = peaks(x,y);
```

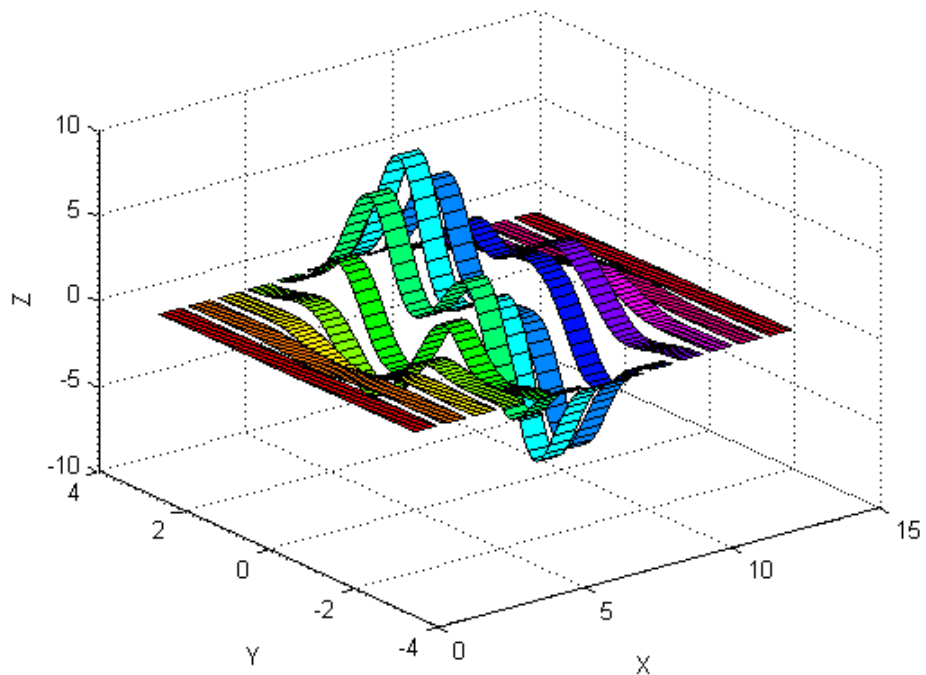

```
ribbon(y,z)
xlabel('X')
ylabel('Y')
zlabel('Z')
colormap hsv
```

**See Also**

[plot](#) | [plot3](#) | [surface](#) | [waterfall](#)

# rmappdata

---

**Purpose** Remove application-defined data

**Syntax** `rmappdata(h,name)`

**Description** `rmappdata(h,name)` removes the application-defined data name from the object specified by handle `h`.

**Tips** Application data is data that is meaningful to or defined by your application which you attach to a figure or any GUI component (other than ActiveX controls) through its `AppData` property. Only Handle Graphics MATLAB objects use this property.

**See Also** `getappdata` | `isappdata` | `setappdata`

**Purpose**

Remove folder

**Syntax**

```
rmdir(folderName)
rmdir(folderName,'s')
[status, message, messageid] = rmdir(folderName,'s')
```

**Description**

`rmdir(folderName)` removes the folder `folderName` from the current folder if `folderName` is empty. If `folderName` is not in the current folder, then specify the relative path or the full path for `folderName`.

`rmdir(folderName,'s')` removes the folder `folderName` and its contents from the current folder. With the 's' option, `rmdir` attempts to remove all subfolders and files in `folderName` regardless of their write permissions.

`[status, message, messageid] = rmdir(folderName,'s')` removes the folder `folderName` and its contents from the current folder, returning the status, a message, and the MATLAB message ID.

**Tips**

- If you specify the 's' flag or include a wildcard in the folder name, MATLAB produces an error if it is unable to remove all folders. The error message lists the folder and files that MATLAB could not remove.

**Input Arguments****folderName**

String specifying the absolute or relative path name of the folder you want to remove.

**Default:** None

**'s'**

Literal string that directs `rmdir` to remove all subfolders and files in the specified folder, regardless of their write permissions. The result for read-only files follows the practices of the operating system.

# rmdir

---

**Default:** `rmdir` does not remove subfolders and files in the specified folder.

## Output Arguments

### **status**

Logical scalar indicating the outcome of the `rmdir` operation. The status value is 1 if the operation was successful and 0 if it returned an error.

### **message**

String containing the warning or error message text if the operation is unsuccessful. An empty string, if the operation is successful.

### **messageid**

String containing the warning or error message ID, if the operation is unsuccessful. MATLAB returns an empty string if the operation is successful.

## Examples

These examples remove an empty folder, `myfiles`, assuming it is in the current folder:

```
% Remove myfiles from the current folder:
```

```
rmdir('myfiles')
```

```
% Use the relative path to remove myfiles. Assuming
% the current folder is matlab/work and myfiles is in
% d:/matlab/work/project, type this:
```

```
rmdir('project/myfiles')
```

```
% Use the full path to remove myfiles, assuming
% the current folder is matlab/work and myfiles is in
% d:/matlab/work/project:
```

```
rmdir('d:/matlab/work/project/myfiles')
```

---

This example removes the `myfiles` folder and its contents, assuming `myfiles` is in the current folder:

```
rmdir('myfiles','s')
```

---

This example unsuccessfully attempts to remove the `myfiles` folder and its contents. It directs MATLAB to display the results.

```
[stat, mess, id]=rmdir('myfiles')
```

MATLAB returns:

```
stat =
 0
```

```
mess =
```

```
No directories were removed.
```

```
id =
```

```
MATLAB:RMDIR:NoDirectoriesRemoved
```

---

This example successfully removes the `myfiles` folder and its contents. It directs MATLAB to display the results.

```
[stat, mess]=rmdir('myfiles','s')
```

MATLAB returns:

```
stat =
 1
```

```
mess =
```

# rmdir

---

..

## **Alternatives**

Open the Current Folder browser by running `filebrowser`. Then, in the Current Folder browser, right-click the folder name and select **Delete** from the context menu.

## **See Also**

| `cd` | `copyfile` | `delete` | `dir` | `fileattrib` | `filebrowser` | `mkdir`  
| `movefile`

<b>Purpose</b>	Remove folder on FTP server
<b>Syntax</b>	<code>rmdir(ftpobj, folder)</code>
<b>Description</b>	<code>rmdir(ftpobj, folder)</code> removes the specified folder from the current folder on an FTP server.
<b>Input Arguments</b>	<p><b>ftpobj</b> FTP object created by <code>ftp</code>.</p> <p><b>folder</b> String enclosed in single quotation marks that specifies the name of the folder to delete.</p>
<b>Examples</b>	<p>Remove the folder <code>temp</code> from the hypothetical FTP server <code>ftp.testsite.com</code>:</p> <pre>test = ftp('ftp.testsite.com'); rmdir(test, 'temp');</pre>
<b>See Also</b>	<code>cd</code>   <code>delete</code>   <code>dir</code>   <code>ftp</code>   <code>mkdir</code>

# rmfield

---

**Purpose** Remove fields from structure

**Syntax** `s = rmfield(s,field)`

**Description** `s = rmfield(s,field)` removes the specified field or fields from structure array `s`. Specify multiple fields using a cell array of strings. The dimensions of `s` remain the same.

## Input Arguments

### **s** - Input structure

structure array

Input structure, specified as a structure array.

### **Data Types**

struct

### **field** - Field name or names

character array | cell array of strings

Field name or names, specified as a character array or a cell array of strings.

**Example:** `'f1'`

**Example:** `{'f1';'f2'}`

### **Data Types**

char | cell

## Examples

### **Remove Single Field**

Define a scalar structure with fields named `a`, `b`, and `c`.

```
s.a = 1;
s.b = 2;
s.c = 3;
```

Remove field `b`.

```
field = 'b';
```



```
s = rmfield(s,field)
```

```
s =
 a: 1
 c: 3
```

### Remove Multiple Fields

Define a scalar structure with fields `first`, `second`, `third`, and `fourth`.

```
S.first = 1;
S.second = 2;
S.third = 3;
S.fourth = 4;
```

Remove fields `first` and `fourth`.

```
fields = {'first','fourth'};
S = rmfield(S,fields)
```

```
S =
 second: 2
 third: 3
```

### See Also

[fieldnames](#) | [isfield](#) | [orderfields](#)

### Concepts

- “Generate Field Names from Variables”

# rmpath

---

<b>Purpose</b>	Remove folders from search path
<b>Syntax</b>	<code>rmpath(folderName)</code>
<b>Description</b>	<code>rmpath(folderName)</code> removes the specified folder from the search path.
<b>Input Arguments</b>	<p><b>folderName - Name of folder</b> string</p> <p>Name of folder to remove from the search path, specified as a string. Use the full path name for <code>folderName</code>.</p> <p><b>Example:</b> <code>'c:\matlab\work'</code></p> <p><b>Example:</b> <code>'/home/user/matlab'</code></p>
<b>Examples</b>	<p><b>Remove Folder from Search Path</b></p> <p>Remove <code>/usr/local/matlab/mytools</code> from the search path.</p> <pre>rmpath('/usr/local/matlab/mytools')</pre>
<b>See Also</b>	<code>addpath</code>   <code>savepath</code>   <code>path</code>
<b>Concepts</b>	<ul style="list-style-type: none"><li>• “What Is the MATLAB Search Path?”</li></ul>

**Purpose**

Remove preference

**Syntax**

```
rmpref('group','pref')
rmpref('group',{'pref1','pref2',... 'prefn'})
rmpref('group')
```

**Description**

`rmpref('group','pref')` removes the preference specified by `group` and `pref`. It is an error to remove a preference that does not exist.

`rmpref('group',{'pref1','pref2',... 'prefn'})` removes each preference specified in the cell array of preference names. It is an error if any of the preferences do not exist.

`rmpref('group')` removes all the preferences for the specified group. It is an error to remove a group that does not exist.

**Examples**

```
addpref('mytoolbox','version','1.0')
rmpref('mytoolbox')
```

**See Also**

`addpref` | `getpref` | `ispref` | `setpref` | `uigetpref` | `uisetpref`

# rng

---

**Purpose** Control random number generation

**Syntax**

```
rng(sd)
rng('shuffle')
rng(sd, generator)
rng('shuffle', generator)
rng('default')
scurr = rng
rng(s)
sprex = rng(...)
```

## Description

---

**Note** To use the `rng` function instead of `rand` or `randn` with the 'seed', 'state', or 'twister' inputs, see the documentation on “Replace Discouraged Syntaxes of `rand` and `randn`”

---

`rng(sd)` seeds the random number generator using the nonnegative integer `sd` so that `rand`, `randi`, and `randn` produce a predictable sequence of numbers.

`rng('shuffle')` seeds the random number generator based on the current time so that `rand`, `randi`, and `randn` produce a different sequence of numbers after each time you call `rng`.

`rng(sd, generator)` and `rng('shuffle', generator)` additionally specify the type of the random number generator used by `rand`, `randi`, and `randn`. The generator input is one of:

Generator	Description
'twister'	Mersenne Twister
'combRecursive'	Combined Multiple Recursive
'multFibonacci'	Multiplicative Lagged Fibonacci
'v5uniform'	Legacy MATLAB 5.0 uniform generator

Generator	Description
'v5normal'	Legacy MATLAB 5.0 normal generator
'v4'	Legacy MATLAB 4.0 generator

`rng('default')` puts the settings of the random number generator used by `rand`, `randi`, and `randn` to their default values so that they produce the same random numbers as if you restarted MATLAB. In this release, the default settings are the Mersenne Twister with seed 0.

`scurr = rng` returns the current settings of the random number generator used by `rand`, `randi`, and `randn`. The settings are returned in a structure `scurr` with fields `'Type'`, `'Seed'`, and `'State'`.

`rng(s)` restores the settings of the random number generator used by `rand`, `randi`, and `randn` back to the values captured previously with a command such as `s = rng`.

`sprev = rng(...)` returns the previous settings of the random number generator used by `rand`, `randi`, and `randn` before changing the settings.

## Examples

### Example 1 – Retrieve and Restore Generator Settings

Save the current generator settings in `s`:

```
s = rng;
```

Call `rand` to generate a vector of random values:

```
x = rand(1,5)
```

```
x =
```

```
 0.8147 0.9058 0.1270 0.9134 0.6324
```

Restore the original generator settings by calling `rng`. Generate a new set of random values and verify that `x` and `y` are equal:

```
rng(s);
y = rand(1,5)
```

```
y =
 0.8147 0.9058 0.1270 0.9134 0.6324
```

## Example 2 – Restore Settings for Legacy Generator

Use the legacy generator.

```
sprev = rng(0, 'v5uniform')
```

```
sprev =
 Type: 'twister'
 Seed: 0
 State: [625x1 uint32]
```

```
x = rand
```

```
x =
 0.9501
```

Restore the previous settings by calling `rng`:

```
rng(sprev)
```

### See Also

```
rand | randi | randn | RandStream | now
```

### Related Examples

- “Generate Random Numbers That Are Repeatable”
- “Generate Random Numbers That Are Different”

### Concepts

- “Why Do Random Numbers Repeat After Startup?”

**Purpose** Root

**Description** The root is a graphics object that corresponds to the computer screen. There is only one root object and it has no parent. The children of the root object are figures.

The root object exists when you start MATLAB; you never have to create it and you cannot destroy it. Use `set` and `get` to access the root properties.

**Object Hierarchy**

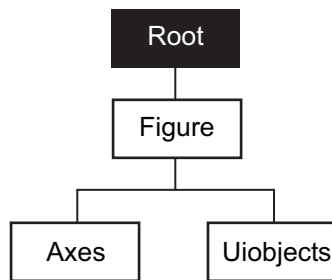

**See Also** [diary](#) | [echo](#) | [figure](#) | [format](#) | [gcf](#) | [get](#) | [set](#) | [Root Properties](#)

# Root Properties

---

**Purpose** Root properties

## Modifying Properties

You can set and query graphics object properties in two ways:

- Property Editor is an interactive tool that enables you to see and change object property values.
- The set and get commands enable you to set and query the values of properties.

To change the default values of properties, see “Setting Default Property Values”.

## Root Properties

This section provides a description of properties. Curly braces { } enclose default values.

BusyAction

cancel | {queue}

Not used by the root object.

ButtonDownFcn

string

Not used by the root object.

CallbackObject

handle (read-only)

*Handle of current callback's object.* Contains the handle of the object whose callback routine is currently executing. If no callback routines are executing, this property contains an empty double array [ ]. See also the `gco` command.

Children

vector of handles

*Handles of child objects.* A vector containing the handles of all nonhidden figure objects (see `HandleVisibility` for more



information). You can change the order of the handles and thereby change the sorting order of the figures on the display.

## Clipping

{on} | off

*Clipping mode.* This property has no effect on the root object.

## CommandWindowSize

[columns rows]

---

**Note** The `CommandWindowSize` root property will be removed in a future release. To determine the number of columns and rows that display in the Command Window, given its current size, call `matlab.desktop.commandwindow.size`.

---

*Current size of command window.* Size of the MATLAB command window, in a two-element vector. The first element is the number of columns wide and the second element is the number of rows tall.

For example, a value of `[50,25]` means that 50 characters can display across the Command Window, and 25 lines can display without scrolling.

Enabling the Command Window Display preference **Set matrix display width to eighty columns** forces the returned value for number of columns wide to be 80 regardless of the window width.

## CreateFcn

The root object does not use this property.

## CurrentFigure

figure handle

*Handle of the current figure,* which is the one most recently created, clicked in, or made current with the statement:

# Root Properties

---

```
figure(h) % h is a figure handle
```

which re-sorts the figure to the top of the figures displayed on the screen, or:

```
set(0, 'CurrentFigure', h)
```

which does not re-sort the figures. In these statements, `h` is the handle of an existing figure. If there are no figure objects:

```
get(0, 'CurrentFigure')
```

returns an empty double array. Note, however, that `gcf` always returns a figure handle. Calling `gcf` creates a new figure if there are no existing figure objects that can become the current figure (for example, figures with hidden handles cannot become the current figure).

DeleteFcn  
string

This property is not used because you cannot delete the root object.

Diary  
on | {off}

*Diary file mode.* When this property is on, MATLAB maintains a file (whose name is specified by the `DiaryFile` property) that saves a copy of all keyboard input and most of the resulting output. See also the `diary` command.

DiaryFile  
string

*Diary file name.* The default name is `diary`. Set this property to the name of the file MATLAB uses write the command-line diary when the `Diary` property is set to on.

Echo  
on | {off}

*Script echoing mode.* When Echo is on, MATLAB displays each line of a script file as it executes. See also the `echo` command.

ErrorMessage  
string

*Text of last error message.* Contains the last error message issued by MATLAB.

FixedWidthFontName  
font name

*Fixed-width font to use for axes, text, and uicontrols whose FontName is set to FixedWidth.* MATLAB uses the font name specified for this property as the value for axes, text, and uicontrol FontName properties when their FontName property is FixedWidth.

Specifying the font name with this property eliminates the need to hardcode font names in MATLAB applications and thereby enables these applications to run without modification in locales where non-ASCII character sets are required. In these cases, MATLAB attempts to set the value of FixedWidthFontName to the correct value for a given locale.

MATLAB application developers should not change this property, but should create axes, text, and uicontrols with FontName properties set to FixedWidth when they want to use a fixed-width font for these objects.

MATLAB end users can set this property if they do not want to use the preselected value. Courier is the default in locales that use Latin-based characters.

Format  
short | {shortE} | long | longE | bank |  
hex | + | rat

# Root Properties

---

*Output format mode.* Format used to display numbers. See also the `format` command.

- `short` — Fixed-point format with 5 digits
- `shortE` — Floating-point format with 5 digits
- `shortG` — Fixed- or floating-point format displaying as many significant figures as possible with 5 digits
- `long` — Scaled fixed-point format with 15 digits
- `longE` — Floating-point format with 15 digits
- `longG` — Fixed- or floating-point format displaying as many significant figures as possible with 15 digits
- `bank` — Fixed-format of dollars and cents
- `hex` — Hexadecimal format
- `+` — Displays + and - symbols
- `rat` — Approximation by ratio of small integers

`FormatSpacing`  
`compact` | `{loose}`

*Output format spacing* (see also `format` command).

- `compact` — Suppress extra line feeds for more compact display.
- `loose` — Display extra line feeds for a more readable display.

`HandleVisibility`  
`{on}` | `callback` | `off`

This property is not useful on the root object because the handle is always 0.

`HitTest`  
`{on}` | `off`

This property is not useful on the root object.

Interruptible  
{on} | off

This property is not useful on the root object.

Language  
string

System environment setting.

MonitorPositions

*Width and height of monitors, in pixels.* Contains information about the size and relative location of monitors connected to your computer. The information returned by the `MonitorPosition` property depends on which computer system you are using.

## Windows Systems

Windows systems define one monitor as device 1, which becomes the reference by which MATLAB determines other monitor positions. The position data is of the form:

```
[xmin2,ymin2,xmax2,ymax2;
 xmin1,ymin1,xmax1,ymax1]
```

The values for minimum and maximum are relative to the origin.

The following picture show the values returned when querying the `MonitorPositions` property on a Windows system having two monitors arranged as shown.

# Root Properties

Windows System with Two Monitors

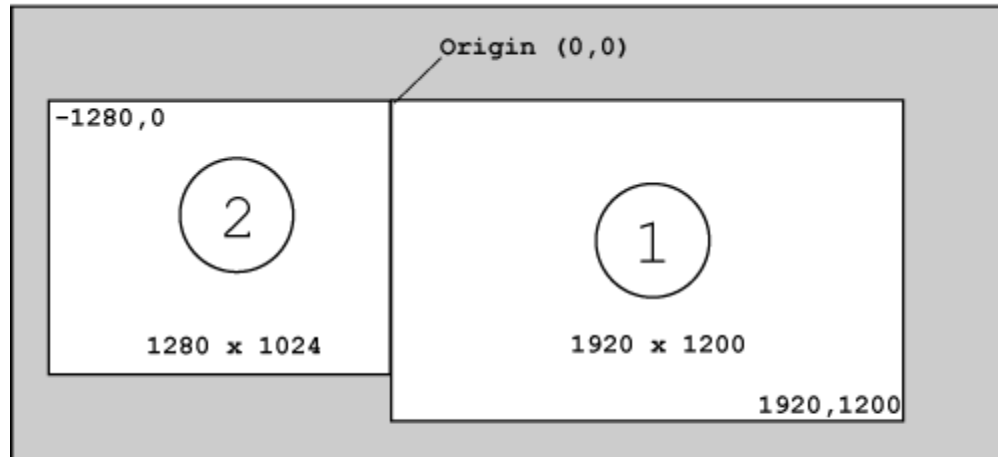

```
get(0, 'MonitorPosition')
```

```
-1279 1 0 1024
 1 1 1920 1200
```

The `MonitorPositions` property contains an n-by-4 array, with each row representing a monitor position. The first row is the n<sup>th</sup> monitor and the last row corresponds to device 1.

The monitor labeled as device 1 in the Windows control panel remains the reference monitor that defines the position of the origin however you reposition the monitors.

## Linux Systems

On Linux systems, the upper-left corner of a rectangle enclosing the system monitors forms the origin. The position data is of the form:

```
[xp yp widthp heightp;
 xs ys widths heights]
```

Where the values represent the offset from the left (x), the offset from the top (y), and the width and height of the monitor. The `MonitorPositions` property contains an n-by-4 array, with each row representing a monitor position. The first row is the position of the primary monitor.

The following picture show the values returned when querying the `MonitorPositions` property on a Linux system that has two monitors arranged as shown.

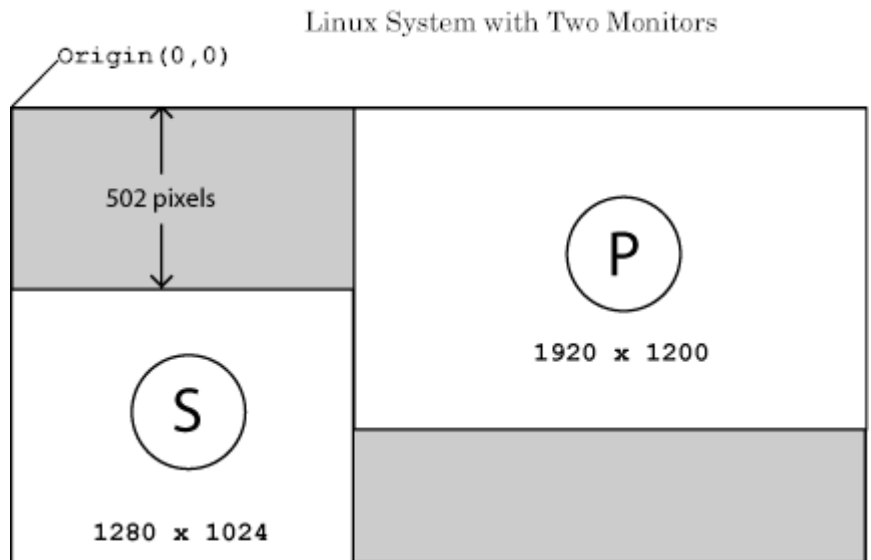

```
get(0, 'MonitorPosition')
```

```
1281 0 1920 1200
 1 503 1280 1024
```

# Root Properties

---

MATLAB on Linux reads control panel settings only at startup. MATLAB does not recognize changes made to the arrangement of monitors during a MATLAB session.

## Macintosh Systems

MATLAB on Macintosh systems recognize only the main monitor. The position data is of the form:

[x,y,width,height-menuHeight]

Where the values are  $x = 0$ ,  $y = 0$ , monitor width, and monitor height minus the height of the menubar.

The main monitor is determined by which display has the menu bar. The **System Preferences Displays** control panel provides a way to arrange representations of multiple displays, and set one as the main monitor. To make another display the main monitor, drag the representation of the menu bar in the panel from the default display to the other display.

Parent  
handle

*Handle of parent object.* This property always contains an empty double array, because the root object has no parent.

PointerLocation  
[x,y]

*Current location of pointer.* A vector containing the  $x$ - and  $y$ -coordinates of the pointer position, measured from the lower left corner of the screen. Move the pointer by changing the values of this property. The Units property determines the units of this measurement.

PointerLocation always contains the current pointer location, even if the pointer is not in a MATLAB window. A callback



routine querying the `PointerLocation` property can get a value that is different from the location of the pointer when the callback was triggered. This difference results from delays in callback execution caused by competition for system resources.

On Apple Macintosh platforms, you cannot change the pointer location using the `set` command.

## `PointerWindow`

handle (read-only)

*Handle of window containing the pointer.* MATLAB sets this property to the handle of the figure containing the pointer. If the pointer is not in a MATLAB window, the value of this property is 0. A callback routine querying the `PointerWindow` can get the wrong window handle if you move the pointer to another window before the callback executes. This error results from delays in callback execution caused by competition for system resources.

## `RecursionLimit`

integer

*Number of nested MATLAB file calls.* The limit of the number of nested calls to MATLAB files that MATLAB makes before stopping (or potentially running out of memory). By default the value is set to a large value. Setting this property to a smaller value (something like 150, for example) should prevent MATLAB from running out of memory and instead causes MATLAB to issue an error when it reaches the limit.

## `ScreenDepth`

bits per pixel

*Screen depth.* The depth of the display bitmap (the number of bits per pixel). The maximum number of simultaneously displayed colors on the current graphics device is 2 raised to this power.

# Root Properties

---

`ScreenDepth` supersedes the `BlackAndWhite` property. To override automatic hardware checking, set this property to 1. Then MATLAB assumes the display is monochrome. Setting `ScreenDepth` to 1 is useful if MATLAB is running on color hardware but is being displayed on a monochrome terminal. Such a situation can cause MATLAB to determine erroneously that the display is color.

`ScreenPixelsPerInch`  
Display resolution

*DPI setting for your display.* Contains the setting of your display resolution specified in your system preferences.

`ScreenSize`  
four-element rectangle vector (read-only)

*Screen size.* A four-element vector:

[left,bottom,width,height]

that defines the display size. `left` and `bottom` are 0 for all Units except pixels, in which case `left` and `bottom` are both 1. `width` and `height` are the screen dimensions in units specified by the `Units` property.

## Determining Screen Size

Note that the screen size in absolute units (for example, inches) is determined by dividing the number of pixels in width and height by the screen DPI (see the `ScreenPixelPerInch` property). This value is approximate and might not represent the actual size of the screen.

Note that the `ScreenSize` property is static. Its values are read-only at MATLAB startup and not updated if system display settings change. Also, the values returned might not represent

the usable screen size for application developers due to the presence of other GUIs, such as the Microsoft Windows task bar.

**Selected**  
on | off

This property has no effect on the root object.

**SelectionHighlight**  
{on} | off

This property has no effect on the root object.

**ShowHiddenHandles**  
on | {off}

*Show or hide handles marked as hidden.* When set to on, this property disables handle hiding and exposes all object handles regardless of the setting of an object's `HandleVisibility` property. When set to off, all objects so marked remain hidden within the graphics hierarchy.

**Tag**  
string

*User-specified object label.* Provides a means to identify graphics objects with a user-specified label. While it is not necessary to identify the root object with a tag (since its handle is always 0), you can use this property to store any string value, which you can later retrieve using `get`.

**Type**  
string (read-only)

*Class of graphics object.* For the root object, `Type` is always the string `root`.

**UIContextMenu**  
handle

# Root Properties

---

This property is not used by the root object.

## Units

{pixels} | normalized | inches | centimeters | points  
| characters

*Unit of measurement.* Specifies the units MATLAB uses to interpret size and location data contained in the `PointerLocation` and `ScreenSize` properties. All units are measured from the lower left corner of the screen.

- `normalized` — Map the lower left corner of the screen to (0,0) and the upper right corner to (1.0,1.0).
- `inches`, `centimeters`, and `points` — Absolute units. 1 point =  $1/72$  inch.
- `characters` — Based on the size of characters in the default system font. The width of one `characters` unit is the width of the letter x, and the height of one `characters` unit is the distance between the baselines of two lines of text.

If you change the value of `Units`, it is good practice to return it to its default value after completing your operation, so as not to affect other functions that assume `Units` is set to the default value.

## UserData

matrix

*User-specified data.* Data you want to associate with the root object. The default value is an empty array. MATLAB does not use this data, but you can access it using the `set` and `get` commands.

## Visible

{on} | off

*Object visibility.* This property has no effect on the root object.

## See Also

root object

**Purpose**

Polynomial roots

**Syntax**

`r = roots(c)`

**Description**

`r = roots(c)` returns a column vector whose elements are the roots of the polynomial `c`.

Row vector `c` contains the coefficients of a polynomial, ordered in descending powers. If `c` has  $n+1$  components, the polynomial it represents is  $c_1s^n + \dots + c_n s + c_{n+1}$ .

**Tips**

Note the relationship of this function to `p = poly(r)`, which returns a row vector whose elements are the coefficients of the polynomial. For vectors, `roots` and `poly` are inverse functions of each other, up to ordering, scaling, and roundoff error.

**Examples**

The polynomial  $s^3 - 6s^2 - 72s - 27$  is represented in MATLAB software as

```
p = [1 -6 -72 -27]
```

The roots of this polynomial are returned in a column vector by

```
r = roots(p)
```

```
r =
 12.1229
 -5.7345
 -0.3884
```

**Algorithms**

The algorithm simply involves computing the eigenvalues of the companion matrix:

```
A = diag(ones(n-1,1),-1);
A(1,:) = -c(2:n+1)./c(1);
eig(A)
```

# roots

---

It is possible to prove that the results produced are the exact eigenvalues of a matrix within roundoff error of the companion matrix  $A$ , but this does not mean that they are the exact roots of a polynomial with coefficients within roundoff error of those in  $c$ .

## See Also

`fzero` | `poly` | `residue`

**Purpose**

Angle histogram plot

**Syntax**

```
rose(theta)
rose(theta,x)
rose(theta,nbins)
rose(axes_handle,...)
h = rose(...)
[tout,rout] = rose(...)
```

**Description**

`rose(theta)` creates an angle histogram, which is a polar plot showing the distribution of values grouped according to their numeric range, showing the distribution of `theta` in 20 angle bins or less. The vector `theta`, expressed in radians, determines the angle of each bin from the origin. The length of each bin reflects the number of elements in `theta` that fall within a group, which ranges from 0 to the greatest number of elements deposited in any one bin.

`rose(theta,x)` uses the vector `x` to specify the number and the locations of bins. `length(x)` is the number of bins and the values of `x` specify the center angle of each bin. For example, if `x` is a five-element vector, `rose` distributes the elements of `theta` in five bins centered at the specified `x` values.

`rose(theta,nbins)` plots `nbins` equally spaced bins in the range `[0, 2*pi]`. The default is 20.

`rose(axes_handle,...)` plots into the axes with handle `axes_handle` instead of the current axes (`gca`).

`h = rose(...)` returns the handle of the line object used to create the graph.

`[tout,rout] = rose(...)` returns the vectors `tout` and `rout` so `polar(tout,rout)` generates the histogram for the data. This syntax does not generate a plot.

## Examples

### Create Rose Histogram

Load the `sunspot.dat` data set which contains the 2-column matrix `sunspot`. Store the second column of the data set as `theta`.

```
load sunspot.dat
theta = sunspot(:,2);
```

Create a rose histogram of `theta` using 12 bins.

```
figure
rose(theta,12)
```

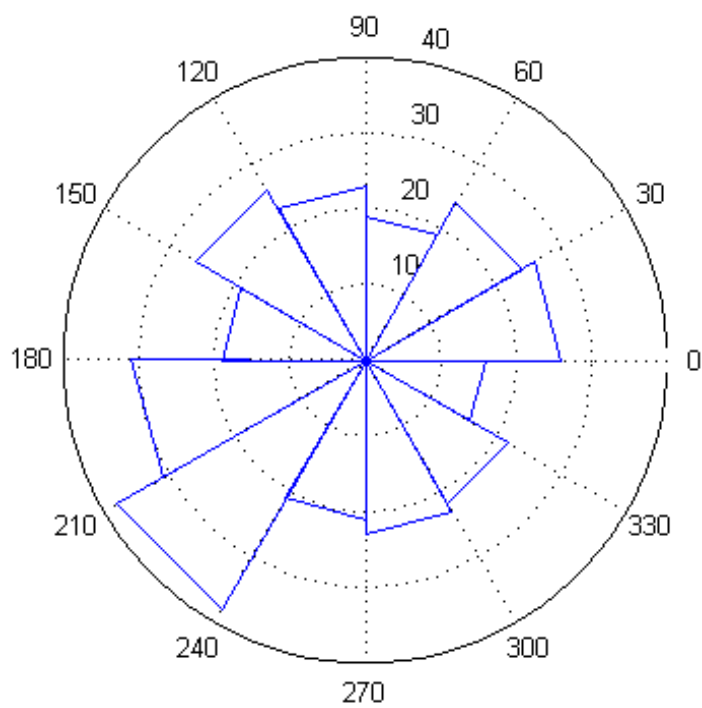

**See Also**

[compass](#) | [feather](#) | [hist](#) | [line](#) | [polar](#)

# rosser

---

**Purpose** Classic symmetric eigenvalue test problem

**Syntax** A = rosser  
A = rosser(classname)

**Description** A = rosser returns the Rosser matrix in double precision.

A = rosser(classname) returns the Rosser matrix with a class specified by `classname`. Specify `classname` as 'single' to return the Rosser matrix in single precision.

**Input Arguments** **classname - Input class**  
'double' (default) | 'single'

Input class, specified as 'double' (default) or 'single'. `rosser(C)` produces a matrix of the specified class.

**Examples** **Generate the Rosser matrix**

`rosser` returns the Rosser matrix.

```
rosser
```

```
ans =
 611 196 -192 407 -8 -52 -49 29
 196 899 113 -192 -71 -43 -8 -44
 -192 113 899 196 61 49 8 52
 407 -192 196 611 8 44 59 -23
 -8 -71 61 8 411 -599 208 208
 -52 -43 49 44 -599 411 208 208
 -49 -8 8 59 208 208 99 -911
 29 -44 52 -23 208 208 -911 99
```

**Generate matrix of class 'single'**

Specify `classname` as `single` to return a Rosser matrix of that class.

```
Y = rosser('single')
```

```
whos('Y')
```

```
Y =
```

```

 611 196 -192 407 -8 -52 -49 29
 196 899 113 -192 -71 -43 -8 -44
 -192 113 899 196 61 49 8 52
 407 -192 196 611 8 44 59 -23
 -8 -71 61 8 411 -599 208 208
 -52 -43 49 44 -599 411 208 208
 -49 -8 8 59 208 208 99 -911
 29 -44 52 -23 208 208 -911 99

```

```

Name Size Bytes Class Attributes
Y 8x8 256 single

```

## Definitions

### Rosser Matrix

The Rosser matrix is a well known matrix used, for example, to evaluate eigenvalue algorithms. The matrix is 8-by-8 with integer elements. It has:

- A double eigenvalue
- Three nearly equal eigenvalues
- Dominant eigenvalues of the opposite sign
- A zero eigenvalue
- A small, nonzero eigenvalue

## See Also

eig

# rot90

---

**Purpose** Rotate array 90 degrees

**Syntax**  
 $B = \text{rot90}(A)$   
 $B = \text{rot90}(A, k)$

**Description**  $B = \text{rot90}(A)$  rotates array  $A$  counterclockwise by 90 degrees. For multidimensional arrays,  $\text{rot90}$  rotates in the plane formed by the first and second dimensions.

$B = \text{rot90}(A, k)$  rotates array  $A$  counterclockwise by  $k \cdot 90$  degrees, where  $k$  is an integer.

**Input Arguments**

**A - Input array**

vector | matrix | array | cell array | categorical array | table

Input array, specified as a vector, matrix, array, cell array, categorical array, or table of data type.

**Complex Number Support:** Yes

**k - Rotation constant**

integer

Rotation constant, specified as an integer. Specify  $k$  to rotate by  $k \cdot 90$  degrees rather than nesting calls to  $\text{rot90}$ .

**Example:**  $\text{rot90}(A, -2)$  rotates  $A$  by -180 degrees and is equivalent to  $\text{rot90}(A, 2)$ , which rotates by 180 degrees.

**Examples**

**Rotate Column Vector**

Create a column vector of sequential elements.

$A = (1:5)'$

$A =$

1  
2

```

3
4
5

```

Rotate A counterclockwise by 90 degrees using rot90.

```
B = rot90(A)
```

```
B =
```

```

1 2 3 4 5

```

The result, B, has the same elements as A but a different orientation.

### Rotate Multidimensional Array

Create a 3-by-3-by-2 cell array of strings.

```
A = cat(3,{'a' 'b' 'c';'d' 'e' 'f';'g' 'h' 'i'},{'j' 'k' 'l';'m' 'n'
```

```
A(:,:,1) =
```

```

'a' 'b' 'c'
'd' 'e' 'f'
'g' 'h' 'i'

```

```
A(:,:,2) =
```

```

'j' 'k' 'l'
'm' 'n' 'o'
'p' 'q' 'r'

```

Rotate the cell array by 270 degrees.

```
B = rot90(A,3)
```

```
B(:,:,1) =
```

# rot90

---

```
'g' 'd' 'a'
'h' 'e' 'b'
'i' 'f' 'c'
```

```
B(:,:,2) =
```

```
'p' 'm' 'j'
'q' 'n' 'k'
'r' 'o' 'l'
```

The function rotates each page of the array independently. Since a full 360 degree rotation ( $k = 4$ ) leaves the array unchanged, `rot90(A,3)` is equivalent to `rot90(A,-1)`.

## Tips

- Use the `flip` function to flip arrays in any dimension.

## See Also

`flip` | `flipud` | `fliplr`

---

<b>Purpose</b>	Rotate object about specified origin and direction
<b>Syntax</b>	<code>rotate(h,direction,alpha)</code> <code>rotate(...,origin)</code>
<b>Description</b>	<p>The <code>rotate</code> function rotates a graphics object in three-dimensional space.</p> <p><code>rotate(h,direction,alpha)</code> rotates the graphics object <code>h</code> by <code>alpha</code> degrees. <code>direction</code> is a two- or three-element vector that describes the axis of rotation in conjunction with the origin of the axis of rotation. The default origin of the axis of rotation is the center of the plot box. This point is not necessarily the origin of the axes.</p> <p>Positive <code>alpha</code> is defined as the righthand-rule angle about the direction vector as it extends from the origin of rotation.</p> <p>If <code>h</code> is an array of handles, all objects must be children of the same axes.</p> <p><code>rotate(...,origin)</code> specifies the origin of the axis of rotation as a three-element vector <code>[x<sub>0</sub>,y<sub>0</sub>,z<sub>0</sub>]</code>.</p>
<b>Tips</b>	<p>The rotation transformation modifies the object's data. This technique is different from that used by <code>view</code> and <code>rotate3d</code>, which modify only the viewpoint.</p> <p>The axis of rotation is defined by an origin of rotation and a point <code>P</code>. Specify <code>P</code> as the spherical coordinates <code>[theta phi]</code> or as the Cartesian coordinates <code>[x<sub>p</sub>,y<sub>p</sub>,z<sub>p</sub>]</code>.</p>

# rotate

---

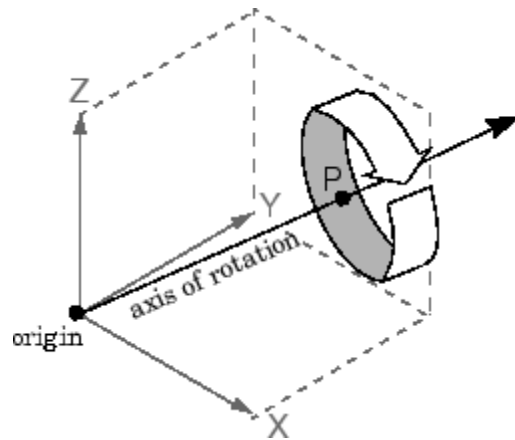

In the two-element form for direction,  $\theta$  is the angle in the  $x$ - $y$  plane counterclockwise from the positive  $x$ -axis.  $\phi$  is the elevation of the direction vector from the  $x$ - $y$  plane.

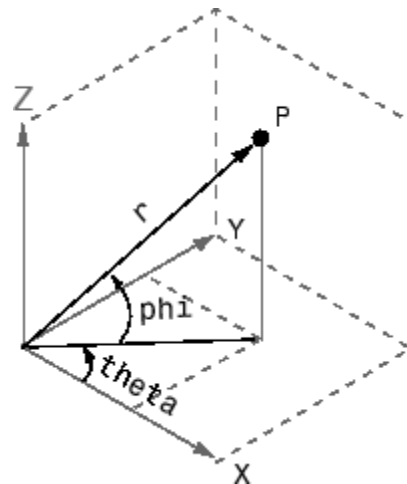

The three-element form for direction specifies the axis direction using Cartesian coordinates. The direction vector is the vector from the origin of rotation to P.



## Examples **Rotate Plot Around x-Axis**

Create a surface plot of the peaks function and return the surface handle.

```
hSurface = surf(peaks(20));
```

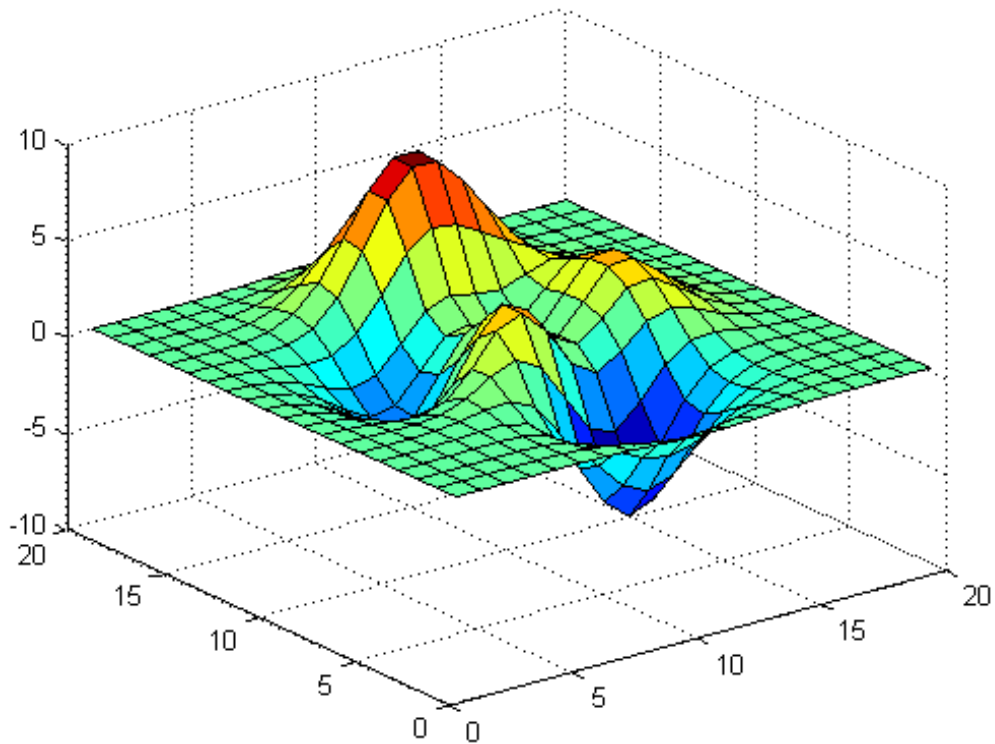

Rotate the surface plot 25 degrees around its x-axis.

```
direction = [1 0 0];
```

# rotate

---

```
rotate(hSurface,direction,25)
```

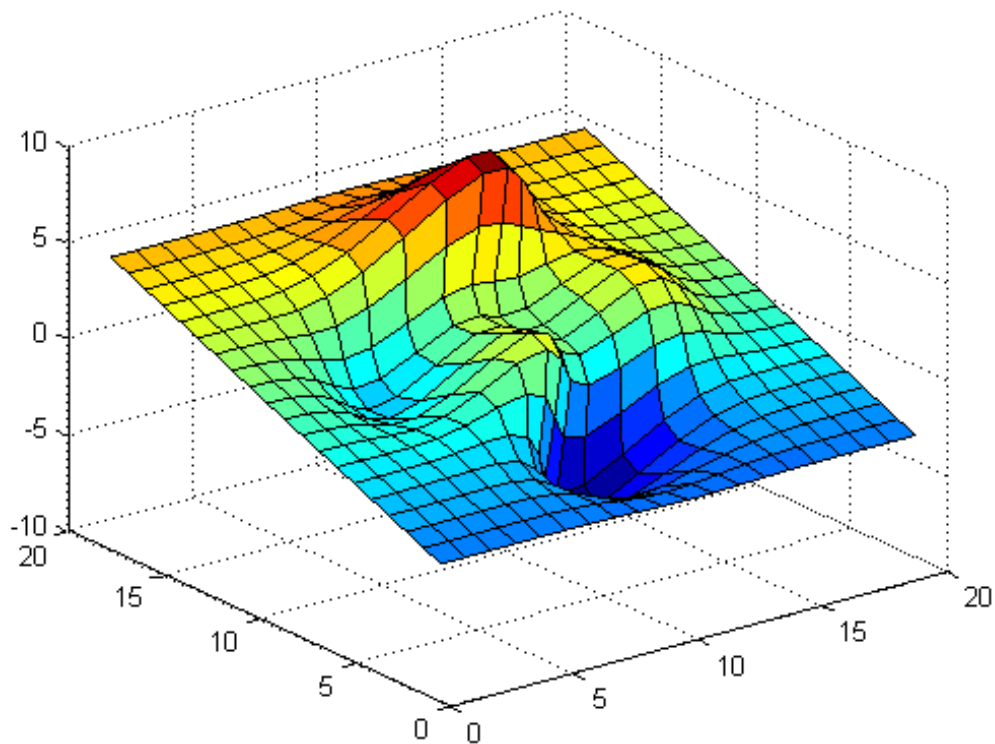

## Rotate Plot Around y-Axis

Create a surface plot of the peaks function and return the surface handle.

```
hSurface = surf(peaks(20));
```

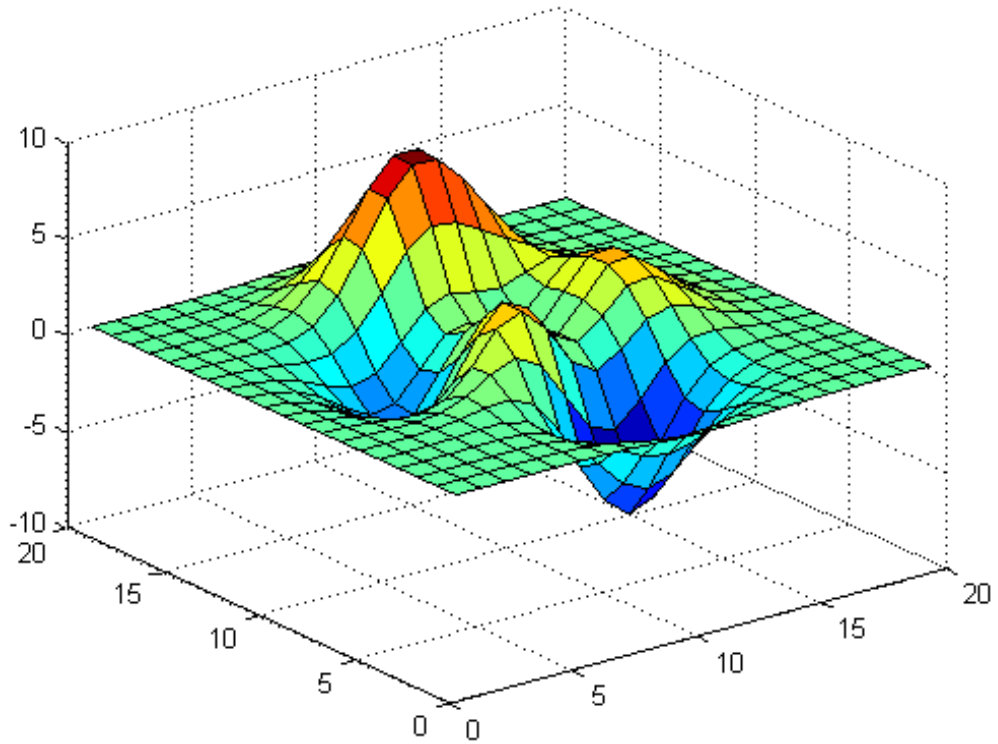

Rotate the surface plot 25 degrees around its y-axis.

```
direction = [0 1 0];
rotate(hSurface,direction,25)
```

# rotate

---

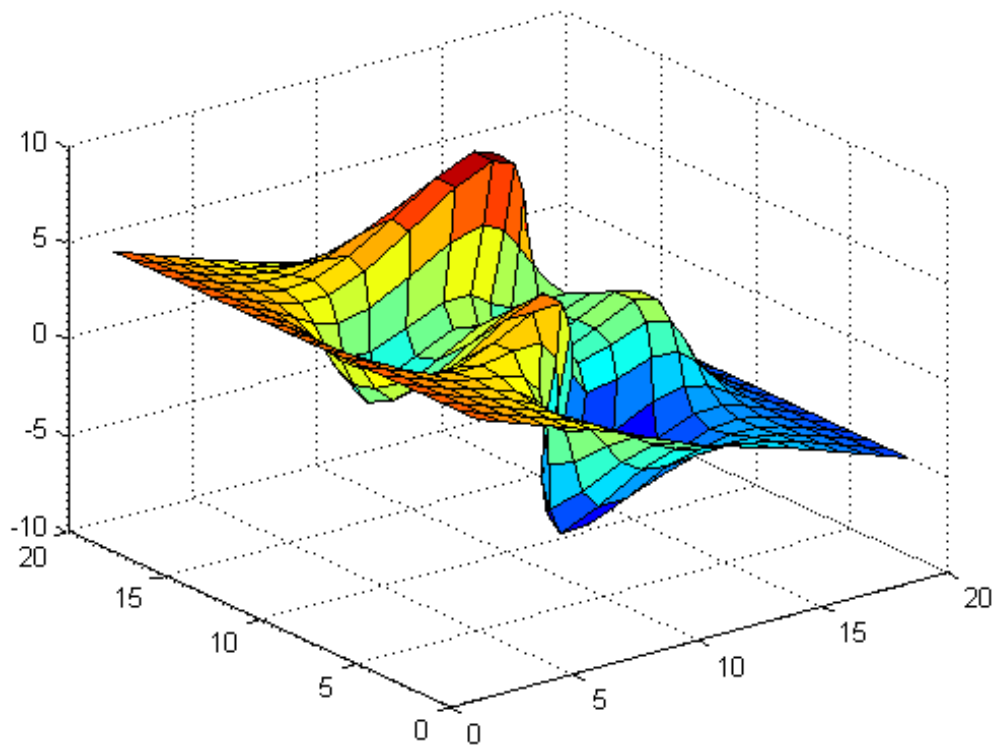

## Rotate Plot Around x-Axis and y-Axis

Create a surface plot of the peaks function and return the surface handle.

```
hSurface = surf(peaks(20));
```

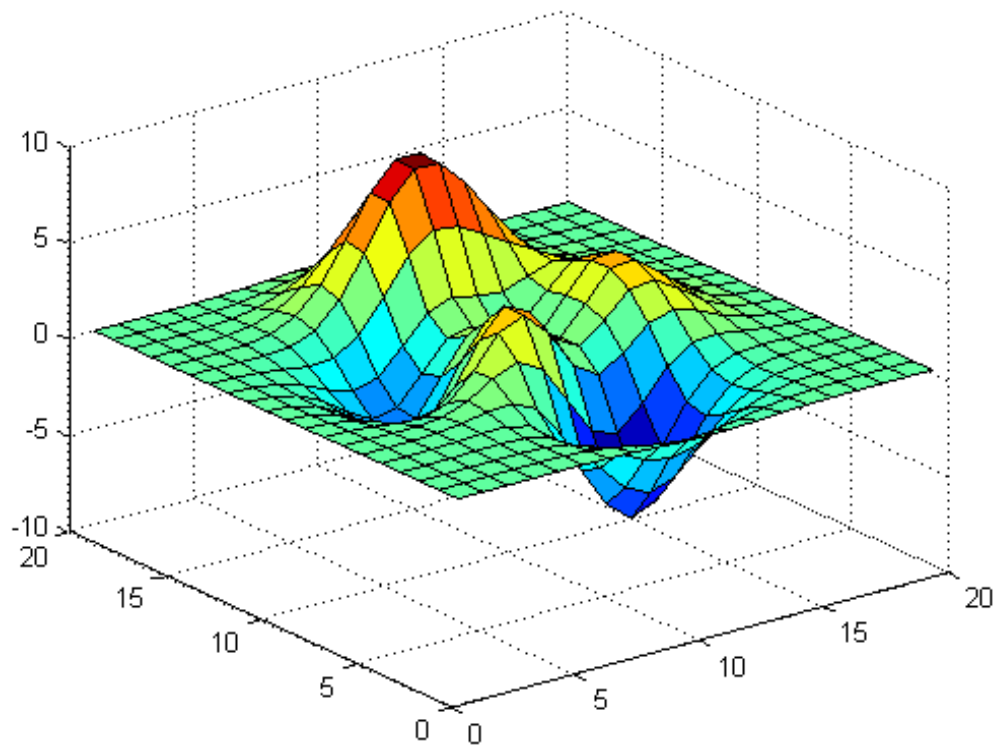

Rotate the surface plot 25 degrees around its  $x$ -axis and  $y$ -axis.

```
direction = [1 1 0];
rotate(hSurface,direction,25)
```

# rotate

---

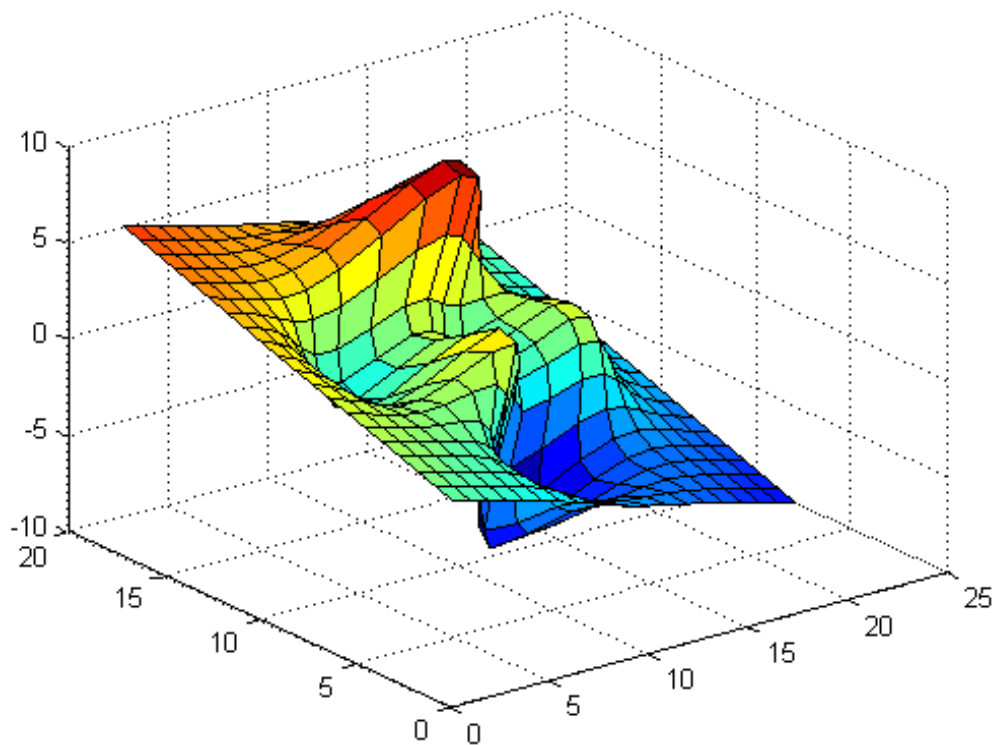

## Tips

rotate changes the values of the Xdata, Ydata, and Zdata properties to rotate graphics objects.

## See Also

rotate3d | sph2cart | view | CameraPosition | CameraTarget | CameraUpVector | CameraViewAngle

**Purpose** Rotate 3-D view using mouse

**Syntax**

```
rotate3d on
rotate3d off
rotate3d
rotate3d(figure_handle,...)
rotate3d(axes_handle,...)
h = rotate3d(figure_handle)
```

**Description**

`rotate3d on` enables mouse-base rotation on all axes within the current figure.

`rotate3d off` disables interactive axes rotation in the current figure.

`rotate3d` toggles interactive axes rotation in the current figure.

`rotate3d(figure_handle,...)` enables rotation within the specified figure instead of the current figure.

`rotate3d(axes_handle,...)` enables rotation only in the specified axes.

`h = rotate3d(figure_handle)` returns a `rotate3d mode object` for figure `figure_handle` for you to customize the mode's behavior.

### Using Rotate Mode Objects

You access the following properties of rotate mode objects via `get` and modify some of them using `set`.

- `FigureHandle <handle>` — The associated figure handle, a read-only property that cannot be set
- `Enable 'on' | 'off'` — Specifies whether this figure mode is currently enabled on the figure
- `RotateStyle 'orbit' | 'box'` — Sets the method of rotation
  - 'orbit' rotates the entire axes; 'box' rotates a plot-box outline of the axes.

## Rotate3D Mode Callbacks

You can program the following callbacks for rotate3d mode operations.

- **ButtonDownFilter** <function\_handle> — Function to intercept ButtonDown events

The application can inhibit the rotate operation under circumstances the programmer defines, depending on what the callback returns. The input function handle should reference a function with two implicit arguments (similar to handle callbacks):

```
function [res] = myfunction(obj,event_obj)
% obj handle to the object that has been clicked on
% event_obj handle to event data object (empty in this release)
% res [output] logical flag to determine whether the rotate
 operation should take place or the 'ButtonDownFcn'
 property of the object should take precedence
```

- **ActionPreCallback** <function\_handle> — Function to execute before rotating

Set this callback to listen to when a rotate operation will start. The input function handle should reference a function with two implicit arguments (similar to Handle Graphics object callbacks):

```
function myfunction(obj,event_obj)
% obj handle to the figure that has been clicked on
% event_obj object containing struct of event data
```

The event data has the following field:

Axes	The handle of the axes that is being panned
------	---------------------------------------------

- **ActionPostCallback** <function\_handle> — Function to execute after rotating



Set this callback to listen to when a rotate operation has finished. The input function handle should reference a function with two implicit arguments (similar to Handle Graphics object callbacks):

```
function myfunction(obj,event_obj)
% obj handle to the figure that has been clicked on
% event_obj object containing struct of event data (same as the
% event data of the 'ActionPreCallback' callback)
```

### Rotate3D Mode Utility Functions

The following functions in pan mode query and set certain of its properties.

- `flags = isAllowAxesRotate(h,axes)` — Function querying permission to rotate axes

Calling the function `isAllowAxesRotate` on the `rotate3d` object, `h`, with a vector of axes handles, `axes`, as input will return a logical array of the same dimension as the axes handle vector which indicate whether a rotate operation is permitted on the axes objects.

- `setAllowAxesRotate(h,axes,flag)` — Function to set permission to pan axes

Calling the function `setAllowAxesRotate` on the `rotate3d` object, `h`, with a vector of axes handles, `axes`, and a logical scalar, `flag`, will either allow or disallow a rotate operation on the axes objects.

## Examples

### Example 1

Rotate the plot using the mouse:

```
surf(peaks);
rotate3d on;
```

### Example 2

Rotate the plot using the "Plot Box" rotate style:

```
surf(peaks);
h = rotate3d;
set(h,'RotateStyle','box','Enable','on');
```

### Example 3

Create two axes as subplots and then prevent one from rotating:

```
ax1 = subplot(1,2,1);
surf(peaks);
h = rotate3d;
set(h,'Enable','on')
ax2 = subplot(1,2,2);
surf(membrane);
setAllowAxesRotate(h,ax2,false); % disable rotating for second plot
```

### Example 4

Create a `ButtonDown` callback for rotate mode objects to trigger. Copy the following code to a new file, execute it, and observe rotation behavior:

```
function demo_mbd
% Allow a line to have its own 'ButtonDownFcn' callback
hLine = plot(rand(1,10));
set(hLine,'ButtonDownFcn','disp(''This executes'')');
set(hLine,'Tag','DoNotIgnore');
h = rotate3d;
set(h,'ButtonDownFilter',@mycallback);
set(h,'Enable','on');
% mouse-click on the line
function [flag] = mycallback(obj,event_obj)
% If the tag of the object is 'DoNotIgnore', then return true
objTag = get(obj,'Tag');
if strcmpi(objTag,'DoNotIgnore')
 flag = true;
else
 flag = false;
end
```

## Example 5

Create callbacks for pre- and post-buttonDown events for rotate3D mode objects to trigger. Copy the following code to a new file, execute it, and observe rotation behavior:

```
function demo_mbd2
% Listen to rotate events
surf(peaks);
h = rotate3d;
set(h,'ActionPreCallback',@myprecallback);
set(h,'ActionPostCallback',@mypostcallback);
set(h,'Enable','on');

function myprecallback(obj,evd)
disp('A rotation is about to occur.');
```

```
function mypostcallback(obj,evd)
newView = round(get(evd.Axes,'View'));
msgbox(sprintf('The new view is [%d %d].',newView));
```

## Tips

When enabled, rotate3d provides continuous rotation of axes and the objects it contains through mouse movement. A numeric readout appears in the lower left corner of the figure during rotation, showing the current azimuth and elevation of the axes. Releasing the mouse button removes the animated box and the readout. This differs from the camorbit function in that while the rotate3d tool modifies the View property of the axes, the camorbit function fixes the aspect ratio and modifies the CameraTarget, CameraPosition and CameraUpVector properties of the axes. See [Axes Properties](#) for more information.

You can also enable 3-D rotation from the figure **Tools** menu or the figure toolbar.

You can create a rotate3d mode object once and use it to customize the behavior of different axes, as example 3 illustrates. You can also change its callback functions on the fly.

---

**Note** Do not change figure callbacks within an interactive mode. While a mode is active (when panning, zooming, etc.), you will receive a warning if you attempt to change any of the figure's callbacks and the operation will not succeed. The one exception to this rule is the figure `WindowButtonMotionFcn` callback, which can be changed from within a mode. Therefore, if you are creating a GUI that updates a figure's callbacks, the GUI should some keep track of which interactive mode is active, if any, before attempting to do this.

---

When you assign different 3-D rotation behaviors to different subplot axes via a mode object and then link them using the `linkaxes` function, the behavior of the axes you manipulate with the mouse will carry over to the linked axes, regardless of the behavior you previously set for the other axes.

## Alternatives

Use the Rotate3D tool  on the figure toolbar to enable and disable `rotate3D` mode on a plot, or select **Rotate 3D** from the figure's **Tools** menu. For details, see “Rotate in 3-D”.

## See Also

`camorbit` | `pan` | `rotate` | `view` | `zoom` | `Axes Properties`

**Purpose** Round to nearest integer

**Syntax**  $Y = \text{round}(X)$

**Description**  $Y = \text{round}(X)$  rounds the elements of  $X$  to the nearest integers. Positive elements with a fractional part of 0.5 round up to the nearest positive integer. Negative elements with a fractional part of -0.5 round down to the nearest negative integer. For complex  $X$ , the imaginary and real parts are rounded independently.

**Examples**  $a = [-1.9, -0.2, 3.4, 5.6, 7.0, 2.4+3.6i]$

```
a =
Columns 1 through 4
-1.9000 -0.2000 3.4000 5.6000
Columns 5 through 6
7.0000 2.4000 + 3.6000i
```

```
round(a)
```

```
ans =
Columns 1 through 4
-2.0000 0 3.0000 6.0000
Columns 5 through 6
7.0000 2.0000 + 4.0000i
```

**See Also** `ceil` | `fix` | `floor`

# rowfun

---

## Purpose

Apply function to table rows

## Syntax

```
B = rowfun(func,A)
B = rowfun(func,A,Name,Value)
```

## Description

`B = rowfun(func,A)` applies the function `func` to each row of the table `A` and returns the results in the table `B`.

`func` accepts `size(A,2)` inputs.

`B = rowfun(func,A,Name,Value)` applies the function `func` to each row of the table `A` with additional options specified by one or more `Name,Value` pair arguments.

For example, you can specify which variables to pass to the function `func` and how to call `func`.

## Input Arguments

### **func** - Function

function handle

Function, specified as a function handle. You can define the function in a file or as an anonymous function. If `func` corresponds to more than one function file (that is, if `func` represents a set of overloaded functions), MATLAB determines which function to call based on the class of the input arguments.

`func` can accept no more than `size(A,2)` inputs. By default, `rowfun` returns the first output of `func`. To return more than one output from `func`, use the `'NumOutputs'` or `'OutputVariableNames'` name-value pair arguments.

**Example:** `func = @(x,y) x.^2+y.^2;` takes two inputs and finds the sum of the squares.

### **A** - Input table

table

Input table, specified as a table.

## Name-Value Pair Arguments

Specify optional comma-separated pairs of `Name`, `Value` arguments. `Name` is the argument name and `Value` is the corresponding value. `Name` must appear inside single quotes ( `' '`). You can specify several name and value pair arguments in any order as `Name1, Value1, ..., NameN, ValueN`.

**Example:** `'InputVariables', 2` uses only the second variable in `A` as an input to `func`.

### 'InputVariables' - Variables of A to pass to func

positive integer | vector of positive integers | variable name | cell array of variable names | logical vector | ...

Variables of `A` to pass to `func`, specified as the comma-separated pair consisting of `'InputVariables'` and a positive integer, vector of positive integers, variable name, cell array of variable names, logical vector, or an anonymous function that returns a logical scalar. If you specify `'InputVariables'` as an anonymous function that returns a logical scalar, `rowfun` only passes the variables in `A` where the specified function returns 1 (`true`).

### 'GroupingVariables' - One or more variables in A that define groups of rows

positive integer | vector of positive integers | variable name | cell array of variable names | logical vector

One or more variables in `A` that define groups of rows, specified as the comma-separated pair consisting of `'GroupingVariables'` and a positive integer, vector of positive integers, variable name, cell array of variable names, or logical vector.

A grouping variable can be a numeric vector, logical vector, string (or character array), cell array of strings, or a categorical vector. Rows in `A` that have the same grouping variable values belong to the same group. `rowfun` applies `func` to each group of rows, rather than separately to each row of `A`. The output, `B`, contains one row for each group.

## **'SeparateInputs' - Indicator for calling func with separate inputs**

true (default) | false | 1 | 0

Indicator for calling func with separate inputs, specified as the comma-separated pair consisting of 'SeparateInputs' and either true, false, 1, or 0.

true                    func expects separate inputs. rowfun calls func with size(A,2) inputs, one argument for each data variable.

This is the default behavior.

false                    func expects one vector containing all inputs. rowfun creates the input vector to func by concatenating the values in each row of A.

## **'ExtractCellContents' - Indicator to pass values from cell variables to func**

false (default) | true | 0 | 1

Indicator to pass values from cell variables to func, specified as the comma-separated pair consisting of 'ExtractCellContents' and either false, true, 0, or 1.

true                    rowfun extracts the contents of a variable in A whose data type is cell and passes the values, rather than the cells, to func

For grouped computation, the values within each group in a cell variable must allow vertical concatenation.

false                    rowfun passes the cells of a variable in A whose data type is cell to func.

This is the default behavior.

## **'OutputVariableNames' - Variable names for outputs of func**

string | cell array of nonempty, distinct strings



Variable names for outputs of `func`, specified as the comma-separated pair consisting of `'OutputVariableNames'` and a string or a cell array of nonempty, distinct strings. The number of strings must equal the number of outputs desired from `func`.

Furthermore, the strings must be valid MATLAB identifiers. If valid MATLAB identifiers are not available for use as variable names, MATLAB uses a cell array of  $N$  strings of the form `{'Var1' ... 'VarN'}` where  $N$  is the number of variables. You can determine valid MATLAB variable names using the function `isvarname`.

### **'NumOutputs' - Number of outputs from func**

0 | positive integer

Number of outputs from `func`, specified as the comma-separated pair consisting of `'NumOutputs'` and 0 or a positive integer. The integer must be less than or equal to the possible number of outputs from `func`.

**Example:** `'NumOutputs',2` causes `rowfun` to call `func` with two outputs.

### **'OutputFormat' - Format of B**

`'table'` (default) | `'uniform'` | `'cell'`

Format of `B`, specified as the comma-separated pair consisting of `'OutputFormat'` and either the string `'table'`, `'uniform'`, or `'cell'`.

`'table'` `rowfun` returns a table with one variable for each output of `func`. For grouped computation, `B`, also contains the grouping variables.

`'table'` allows you to use a function that returns values of different sizes or data types. However, for ungrouped computation, all of the outputs from `func` must have one row each time it is called. For grouped computation, all of the outputs from `func` must have the same number of rows.

This is the default output format.

- 'uniform' rowfun concatenates the values returned by func into a vector. All of the outputs from func must be scalars with the same data type.
- 'cell' rowfun returns B as a cell array. 'cell' allows you to use a function that returns values of different sizes or data types.

### **'ErrorHandler' - Function to call if func fails**

function handle

Function to call if func fails, specified as the comma-separated pair consisting of 'ErrorHandler' and a function handle. Define this function so that it rethrows the error or returns valid outputs for function func.

MATLAB calls the specified error-handling function with two input arguments:

- A structure with these fields:

identifier	Error identifier.
message	Error message text.
index	Row or group index at which the error occurred.
- The set of input arguments to function func at the time of the error.

For example,

```
function [A, B] = errorFunc(S, varargin)
warning(S.identifier, S.message);
A = NaN; B = NaN;
```

## Output Arguments

### B - Output table

table

Output table, returned as a table. The table can store metadata such as descriptions, variable units, variable names, and row names. For more information, see [Table Properties](#).

## Examples

### Apply Function with Single Output to Rows

Apply the function `hypot` to each row of the 5-by-2 table `A` to find the shortest distance between the variables `x` and `y`.

Create a table, `A`, with two variables of numeric data.

```
x = gallery('integerdata',10,[5,1],2);
y = gallery('integerdata',10,[5,1],8);
```

```
A = table(x,y)
```

```
A =
```

```
 x y
 — —
 9 1
 4 5
 3 2
 7 3
 1 10
```

Apply the function, `hypot` to each row of `A`. The function `hypot` takes two inputs and returns one output.

```
B = rowfun(@hypot,A,'OutputVariableNames','z')
```

```
B =
```

```
 z
 —
```

```
9.0554
6.4031
3.6056
7.6158
10.05
```

B is a table.

Append the function output, B, to the input table, A.

```
[A B]
```

```
ans =
```

```
 x y z
 -- -- --
 9 1 9.0554
 4 5 6.4031
 3 2 3.6056
 7 3 7.6158
 1 10 10.05
```

## Apply Function with Multiple Outputs to Rows

Define and apply a geometric Brownian motion model to a range of parameters.

Create a function in a file named `gbmSim.m` that contains the following code.

```
function [m,mtrue,s,strue] = gbmSim(mu,sigma)
% Discrete approximation to geometric Brownian motion
%
% [m,mtrue,s,strue] = gbmSim(mu,sigma) computes the
% simulated mean, true mean, simulated standard deviation,
% and true standard deviation based on the parameters mu and sigma.
```

```

numReplicates = 1000; numSteps = 100;
y0 = 1;
t1 = 1;
dt = t1 / numSteps;
y1 = y0*prod(1 + mu*dt + sigma*sqrt(dt)*randn(numSteps,numReplicates));
m = mean(y1); s = std(y1);
% Theoretical values
mtrue = y0 * exp(mu*t1); strue = mtrue * sqrt(exp(sigma^2*t1) - 1);

```

gbmSim accepts two inputs, mu and sigma, and returns four outputs, m, mtrue, s, and strue.

Define the table, params, containing the parameters to input to the Brownian Motion Model.

```

mu = [-.5; -.25; 0; .25; .5];
sigma = [.1; .2; .3; .2; .1];

```

```

params = table(mu,sigma)

```

```

params =

```

mu	sigma
-0.5	0.1
-0.25	0.2
0	0.3
0.25	0.2
0.5	0.1

Apply the function, gbmSim to the rows of the table, params.

```

stats = rowfun(@gbmSim,params,...
 'OutputVariableNames',...
 {'simulatedMean' 'trueMean' 'simulatedStd' 'trueStd'})

```

```

stats =

```

simulatedMean	trueMean	simulatedStd	trueStd
0.60501	0.60653	0.05808	0.060805
0.77916	0.7788	0.161	0.15733
1.0024	1	0.3048	0.30688
1.2795	1.284	0.25851	0.25939
1.6498	1.6487	0.16285	0.16529

The 4 strings specified by the 'OutputVariableNames' name-value pair argument indicate that rowfun should obtain 4 outputs from gbmSim. You can specify fewer output variable names to return fewer outputs from gbmSim.

Append the function output, stats, to the input, params.

```
[params stats]
```

```
ans =
```

mu	sigma	simulatedMean	trueMean	simulatedStd	trueStd
-0.5	0.1	0.60501	0.60653	0.05808	0.060805
-0.25	0.2	0.77916	0.7788	0.161	0.15733
0	0.3	1.0024	1	0.3048	0.30688
0.25	0.2	1.2795	1.284	0.25851	0.25939
0.5	0.1	1.6498	1.6487	0.16285	0.16529

## Apply Function to Groups of Rows

Create a table, A, where g is a grouping variable.

```
g = gallery('integerdata',3,[15,1],1);
x = gallery('uniformdata',[15,1],9);
y = gallery('uniformdata',[15,1],2);
```

```
A = table(g,x,y)
```

A =

g	x	y
3	0.24756	0.87516
3	0.4358	0.3179
3	0.97755	0.27323
2	0.85995	0.6765
3	0.30063	0.071171
2	0.26589	0.19659
3	0.13338	0.52908
2	0.7425	0.17176
1	0.85692	0.86996
2	0.24286	0.24369
3	0.19492	0.84291
2	0.39076	0.55766
1	0.29683	0.35681
1	0.39031	0.2324
2	0.18726	0.6476

Define the anonymous function, `func`, to compute the average difference between `x` and `y`.

```
func = @(x,y) mean(x-y);
```

Find the average difference between variables in groups 1, 2, and 3 defined by the grouping variable, `g`.

```
B = rowfun(func,A,...
 'GroupingVariable','g',...
 'OutputVariableName','MeanDiff')
```

B =

g	GroupCount	MeanDiff
—	—————	—————

# rowfun

---

1	1	3	0.028298
2	2	6	0.032569
3	3	6	-0.10327

The variable `GroupCount` indicates the number of rows in `A` for each group.

## See Also

`varfun` | `cellfun` | `structfun` | `arrayfun` | `isvarname`

## Concepts

- “Anonymous Functions”



**Purpose** Reduced row echelon form

**Syntax**

```
R = rref(A)
[R, jb] = rref(A)
[R, jb] = rref(A, tol)
```

**Description** `R = rref(A)` produces the reduced row echelon form of `A` using Gauss Jordan elimination with partial pivoting. A default tolerance of  $(\max(\text{size}(A)) * \text{eps} * \text{norm}(A, \text{inf}))$  tests for negligible column elements.

`[R, jb] = rref(A)` also returns a vector `jb` such that:

- `r = length(jb)` is this algorithm's idea of the rank of `A`.
- `x(jb)` are the pivot variables in a linear system  $Ax = b$ .
- `A(:, jb)` is a basis for the range of `A`.
- `R(1:r, jb)` is the `r`-by-`r` identity matrix.

`[R, jb] = rref(A, tol)` uses the given tolerance in the rank tests.

Roundoff errors may cause this algorithm to compute a different value for the rank than `rank`, `orth` and `null`. Additionally, use `mldivide` to solve linear systems when high precision is required.

**Examples** Use `rref` on a rank-deficient magic square:

```
A = magic(4), R = rref(A)
```

```
A =
 16 2 3 13
 5 11 10 8
 9 7 6 12
 4 14 15 1
```

```
R =
 1 0 0 1
 0 1 0 3
```

# rref

---

$$\begin{array}{cccc} 0 & 0 & 1 & -3 \\ 0 & 0 & 0 & 0 \end{array}$$

## See Also

[inv](#) | [lu](#) | [rank](#)

**Purpose** Convert real Schur form to complex Schur form

**Syntax** `[U,T] = rsf2csf(U,T)`

**Description** The *complex Schur form* of a matrix is upper triangular with the eigenvalues of the matrix on the diagonal. The *real Schur form* has the real eigenvalues on the diagonal and the complex eigenvalues in 2-by-2 blocks on the diagonal.

`[U,T] = rsf2csf(U,T)` converts the real Schur form to the complex form.

Arguments `U` and `T` represent the unitary and Schur forms of a matrix `A`, respectively, that satisfy the relationships:  $A = U^*T^*U'$  and  $U' * U = \text{eye}(\text{size}(A))$ . See `schur` for details.

## Examples

Given matrix `A`,

```

1 1 1 3
1 2 1 1
1 1 3 1
-2 1 1 4

```

with the eigenvalues

```

4.8121 1.9202 + 1.4742i 1.9202 + 1.4742i 1.3474

```

Generating the Schur form of `A` and converting to the complex Schur form

```

[u,t] = schur(A);
[U,T] = rsf2csf(u,t)

```

yields a triangular matrix `T` whose diagonal (underlined here for readability) consists of the eigenvalues of `A`.

`U =`

-0.4916	-0.2756 - 0.4411i	0.2133 + 0.5699i	-0.3428
-0.4980	-0.1012 + 0.2163i	-0.1046 + 0.2093i	0.8001
-0.6751	0.1842 + 0.3860i	-0.1867 - 0.3808i	-0.4260
-0.2337	0.2635 - 0.6481i	0.3134 - 0.5448i	0.2466

T =

4.8121	-0.9697 + 1.0778i	-0.5212 + 2.0051i	-1.0067
0	1.9202 + 1.4742i	2.3355	0.1117 + 1.6547i
0	0	1.9202 - 1.4742i	0.8002 + 0.2310i
0	0	0	1.3474

## See Also

schur

---

<b>Purpose</b>	Run MATLAB script
<b>Syntax</b>	<code>run(scriptname)</code>
<b>Description</b>	<code>run(scriptname)</code> runs the MATLAB script specified by <code>scriptname</code> .
<b>Input Arguments</b>	<b>scriptname - Full or relative script path</b> <i>string</i> Full or relative script path to a MATLAB script, specified as a string. <code>scriptname</code> can specify any file type that MATLAB can execute, such as MATLAB script files, Simulink models, or MEX-files.
<b>Tips</b>	<ul style="list-style-type: none"><li>• <code>run</code> executes scripts not currently on the MATLAB path. However, you should use <code>cd</code> or <code>addpath</code> to navigate to or to add the appropriate folder, making a script executable by entering its name alone.</li><li>• <code>scriptname</code> can access any variables in the current workspace.</li><li>• <code>run</code> changes to the folder that contains the script, executes it, and resets back to the original folder. If the script itself changes folders, then <code>run</code> does not revert to the original folder, unless <code>scriptname</code> changes to the folder in which this script resides.</li><li>• If <code>scriptname</code> corresponds to both a <code>.m</code> file and a P-file residing in the same folder, then <code>run</code> executes the P-file. This occurs even if you specify <code>scriptname</code> with a <code>.m</code> extension.</li><li>• If a script is not on the MATLAB path, executing the <code>run</code> command caches the script. In the same session and after calling <code>run</code>, you can edit the script using an external editor. Call <code>clear scriptname</code> before calling <code>run</code> again to use the changed version of the script rather than the cached version. If you edit the script with the MATLAB editor, <code>run</code> executes the changed version and there is no need to call <code>clear scriptname</code>.</li></ul>
<b>Examples</b>	<b>Run Script Not on Current Path</b> Create a temporary folder and copy an example MATLAB script to it.

# run

---

```
tmp = tempname;
mkdir(tmp);
runtmp = fullfile(tmp,'buckyball.m');
demodir = fullfile(matlabroot,'toolbox','matlab',...
 'demos','buckydem.m');
copyfile(demodir,runtmp);
```

Run the new script.

```
run(runtmp)
```

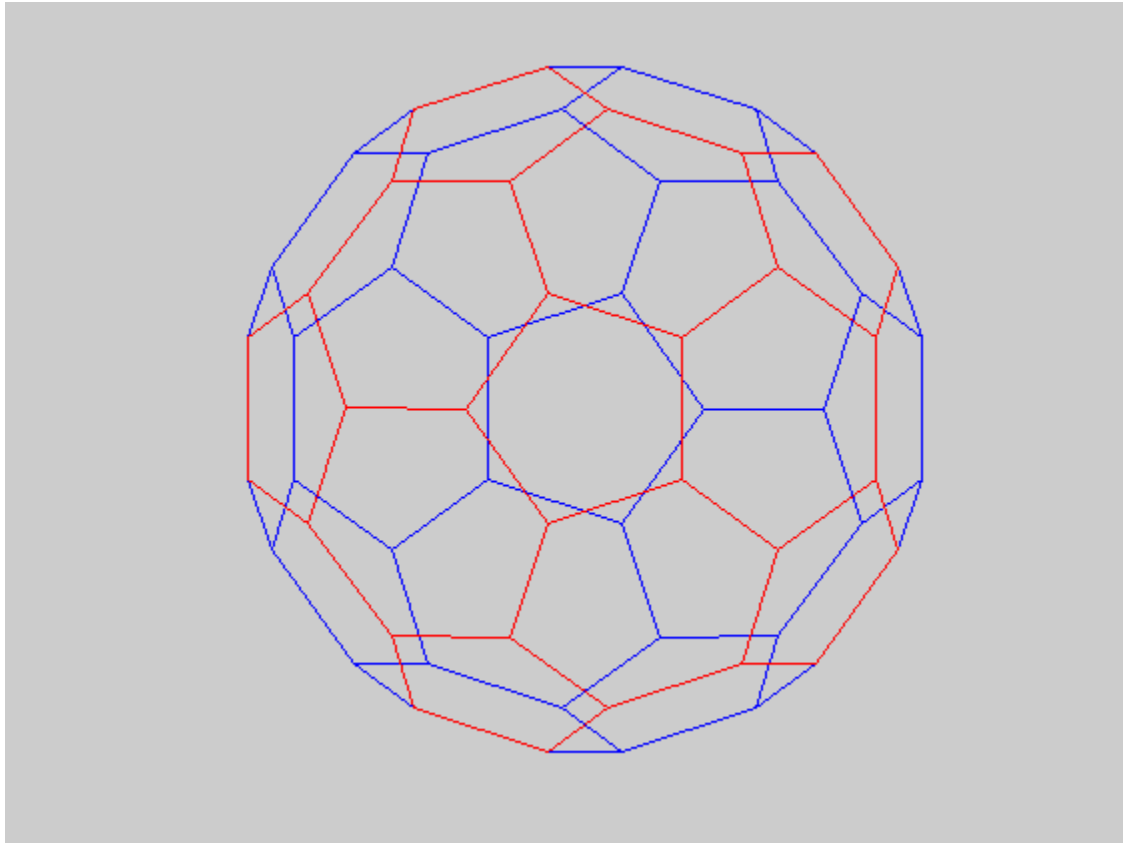

**See Also**

`cd` | `path` | `addpath` | `pwd`

**Concepts**

- “Files and Folders that MATLAB Accesses”

# runtests

---

## Purpose

Run set of tests

## Syntax

```
results = runtests(tests)
results = runtests(tests,Name,Value)
```

## Description

`results = runtests(tests)` runs a set of tests, and returns the results as a `TestResult` object.

`results = runtests(tests,Name,Value)` runs a set of tests with additional options specified by one or more `Name,Value` pair arguments.

## Input Arguments

### tests - Array of tests

string | cell array of strings

Suite of tests specified as a string or cell array of strings. Each string in the cell array can contain the name of a test class, a test file, a package that containing your test classes, or a folder containing your test files.

**Example:** `'mypackage.MyTestClass'`

**Example:** `'ATestFile.m'`

**Example:** `pwd`

**Example:**

```
{'mypackage.MyTestClass','ATestFile.m',pwd,'mypackage.subpackage'}
```

### Name-Value Pair Arguments

Specify optional comma-separated pairs of `Name,Value` arguments. `Name` is the argument name and `Value` is the corresponding value. `Name` must appear inside single quotes (`' '`). You can specify several name and value pair arguments in any order as `Name1,Value1,...,NameN,ValueN`.

**Example:**

**'Recursively' - Indicator to run tests in subfolders and subpackages**



false (default) | true | 0 | 1

Indicator to run tests in subfolders and subpackages, specified as `false` or `true` (0 or 1). By default `runtests` runs tests in the specified folder or package and not in their subfolders or subpackages.

### **Data Types**

logical

### **'Name' - Name of suite element**

string

String indicating the name of the suite element. For the testing framework to run a test, the `Name` property of the test element must match the specified name. Use the wildcard character, `*`, to match any number of characters. Use the question mark character, `?`, to match to exactly one character.

### **'ParameterProperty' - Name of parameterization property**

string

String indicating the name of a property that defines a parameter used by the test suite element. Use the wildcard character, `*`, to match any number of characters. Use the question mark character, `?`, to match to exactly one character.

### **'ParameterName' - Name of parameter**

string

String indicating the name of a parameter used by the test suite element. Use the wildcard character, `*`, to match any number of characters. Use the question mark character, `?`, to match to exactly one character.

### **'BaseFolder' - Name of base folder**

string

String indicating the name of the folder that contains the file defining the test class or function. For the testing framework to run a test, the test element must be contained in the specified base folder. Use the

wildcard character, \*, to match any number of characters. Use the question mark character, ?, to match to exactly one character. For test classes defined in packages, the base folder is the parent of the top-level package folder.

## Examples

### Run Tests Using File Name

Create the test file shown below, and save it as `runtestsExampleTest.m` on your MATLAB path.

```
function tests = runtestsExampleTest
tests = functiontests(localfunctions);
```

```
function testFunctionOne(testCase)
```

Run the tests.

```
results = runtests('runtestsExampleTest.m');
```

```
Running runtestsExampleTest
.
Done runtestsExampleTest
```

---

### Run Tests in Subdirectory

If it doesn't already exist, create the test file, `runtestsExampleTest.m`, in the example above.

Create a subdirectory, `tmpTest`, and, in that directory, create the following `runtestsExampleSubFolderTest.m` file.

```
function tests = runtestsExampleSubFolderTest
tests = functiontests(localfunctions);
```

```
function testFunctionTwo(testCase)
```

Run the tests from the directory above `tmpTest` by setting 'Recursively' to true.

```
results = runtests(pwd, 'Recursively', true);
```

```
Running runtestsExampleTest
```

```
.
Done runtestsExampleTest
```

```
Running runtestsExampleSubFolderTest
```

```
.
Done runtestsExampleSubFolderTest
```

`runtests` ran the tests in both the current directory and the subdirectory.

If you do not specify the `'Recursively'` property for the `runtests` function, it does not run the test in the subdirectory.

```
results = runtests(pwd);
```

```
Running runtestsExampleTest
```

```
.
Done runtestsExampleTest
```

## Run Select Parameterized Tests

In your working folder, create `testZeros.m`. This class contains four test methods.

```
classdef testZeros < matlab.unittest.TestCase
 properties (TestParameter)
 type = {'single', 'double', 'uint16'};
 outSize = struct('s2d', [3 3], 's3d', [2 5 4]);
 end

 methods (Test)
```

## runtests

---

```
function testClass(testCase, type, outSize)
 testCase.verifyClass(zeros(outSize,type), type);
end

function testSize(testCase, outSize)
 testCase.verifySize(zeros(outSize), outSize);
end

function testDefaultClass(testCase)
 testCase.verifyClass(zeros, 'double');
end
function testDefaultSize(testCase)
 testCase.verifySize(zeros, [1 1]);
end

function testDefaultValue(testCase)
 testCase.verifyEqual(zeros,0);
end
end
end
```

The full test suite has 11 test elements: 6 from the `testClass` method, 2 from the `testSize` method, and 1 each from the `testDefaultClass`, `testDefaultSize`, and `testDefaultValue` methods.

At the command prompt, run the test elements that use the `outSize` parameter property.

```
runtests('testZeros','ParameterProperty','outSize')
```

```
Running testZeros
.....
Done testZeros
```

```

ans =
```

1x8 TestResult array with properties:

Name  
Passed  
Failed  
Incomplete  
Duration

Totals:

8 Passed, 0 Failed, 0 Incomplete.  
0.013499 seconds testing time.

**runtests** executed eight tests that use the **outSize** parameter property:  
six from the **testClass** method and two from the **testSize** method.

At the command prompt, run the test elements that use the **singe**  
parameter name.

```
runtests('testZeros', 'ParameterName', 'single')
```

```
Running testZeros
```

```
..
```

```
Done testZeros
```

---

```
c =
```

1x2 TestResult array with properties:

Name  
Passed  
Failed  
Incomplete  
Duration

Totals:

2 Passed, 0 Failed, 0 Incomplete.

# runtests

---

```
0.0034442 seconds testing time.
```

`runtests` executed the two tests from the `testClass` method that use the `outSize` parameter name.

## See Also

[matlab.unittest.TestResult](#) | [matlab.unittest.TestRunner](#) | [matlab.unittest.TestSuite](#) | [functiontests](#)

## Related Examples

- “Write Function-Based Unit Tests”
- “Write Simple Test Case Using Functions”
- “Write Test Using Setup and Teardown Functions”

**Purpose**

Save workspace variables to file

**Syntax**

```
save(filename)
save(filename,variables)
save(filename,variables,fmt)
save(filename,variables,version)
save(filename,variables,'-append')
```

```
save filename
```

**Description**

`save(filename)` saves all variables from the current workspace in a MATLAB formatted binary file (MAT-file) called `filename`. If `filename` already exists, `save` overwrites the file.

`save(filename,variables)` saves only the variables or fields of a structure array specified by `variables`.

`save(filename,variables,fmt)` saves in the file format specified by `fmt`. The `variables` argument is optional. If you do not specify `variables`, the `save` function saves all variables in the workspace.

`save(filename,variables,version)` saves to the MAT-file version specified by `version`. The `variables` argument is optional, as described above.

`save(filename,variables,'-append')` adds new variables to an existing file, and does not overwrite it. The `variables` argument is optional, as described above.

To append to a Version 6 MAT-file, you must also include `'-v6'` as an input argument.

`save filename` is the command form of the syntax. Command form requires fewer special characters. You do not need to type parentheses

or enclose input strings in single quotes. Separate inputs with spaces instead of commas.

For example, to save a file named `test.mat`, these statements are equivalent:

```
save test.mat % command form
save('test.mat') % function form
```

You can include any of the inputs described in previous syntaxes. For example, to save the variable named `X`:

```
save test.mat X % command form
save('test.mat','X') % function form
```

Do not use command form when any of the inputs, such as `filename`, are variables.

## Input Arguments

### **filename** - Name of file

`'matlab.mat'` (default) | string

Name of file, specified as a string. If you do not specify `filename`, the `save` function saves to a file named `matlab.mat`.

If `filename` has no extension (that is, no text after a period), and the value of `format` is `-mat` (the default), then MATLAB appends `.mat`. If `filename` does not include a full path, MATLAB saves to the current folder. You must have permission to write to the file.

When using the command form of `save`, it is unnecessary to enclose input strings in single quotes. However, if `filename` contains a space, you must enclose the argument in single quotes. For example, save `'filename withspace.mat'`.

**Example:** `'myFile.mat'`

### **Data Types**

char

### **variables** - Names of variables to save



string

Names of variables to save, specified as one or more strings. When using the command form of `save`, you do not need to enclose input strings in single quotes. `variables` can be in one of the following forms.

Form of variables Input	Variables to Save
<code>var1, ..., varN</code>	Save the listed variables, specified as individual strings. Use the '*' wildcard to match patterns. For example, <code>save('filename.mat', 'A*')</code> saves all variables in the file that start with A.
<code>'-regex', expr1, ..., exprN</code>	Save only the variables whose names match the regular expressions, specified as strings. For example, <code>save('filename.mat', '-regex', '^Mon', '^Tue')</code> saves only the variables in the file whose names begin with Mon or Tues.
<code>'-struct', structName</code>	Store the fields of the scalar structure specified by <code>structName</code> as individual variables in the file. For example, <code>save('filename.mat', '-struct', 'S')</code> saves the scalar structure, S.
<code>'-struct', structName, field1, field2, ...</code>	Store the specified fields of the specified scalar structure as individual variables in the file. For example, <code>save('filename.mat', '-struct', 'S', 'a', 'b')</code> saves the fields S.a and S.b.
<code>'-struct', structName, '-regex', regex</code>	Store only the fields whose names match the regular expressions, specified as strings.

## Data Types

char

### fmt - File format

```
'-mat' (default) | '-ascii' | '-ascii','-tabs' |
'-ascii','-double' | '-ascii','-double','-tabs'
```

File format, specified as one of the following strings. When using the command form of `save`, you do not need to enclose input strings in single quotes, for example, `save myFile.txt -ascii -tabs`.

Value of <code>fmt</code>	File Format
'-mat'	Binary MAT-file format.
'-ascii'	Text format with 8 digits of precision.
'-ascii','-tabs'	Tab-delimited text format with 8 digits of precision.
'-ascii','-double'	Text format with 16 digits of precision.
'-ascii','-double','-tabs'	Tab-delimited text format with 16 digits of precision.

For MAT-files, data saved on one machine and loaded on another machine retains as much accuracy and range as the different machine floating-point formats allow.

Use one of the text formats to save MATLAB numeric values to text files. In this case:

- Each variable must be a two-dimensional double array.
- The output includes only the real component of complex numbers.
- MATLAB writes data from each variable sequentially to the file. If you plan to use the `load` function to read the file, all variables must have the same number of columns. The `load` function creates a single variable from the file.

If you specify a text format and any variable is a two-dimensional character array, then MATLAB translates characters to their corresponding internal ASCII codes. For example, 'abc' appears in a text file as:

```
9.7000000e+001 9.8000000e+001 9.9000000e+001
```

### version - MAT-file version

```
'-v7.3' | '-v7' | '-v6' | '-v4'
```

MAT-file version, specified as one of the following strings. When using the command form of save, you do not need to enclose input strings in single quotes.

Value of version	Can Load in MATLAB Versions	Supported Features
'-v7.3'	7.3 (R2006b) or later	Version 7.0 features, plus support for data items greater than or equal to 2 GB on 64-bit systems.
'-v7'	7.0 (R14) or later	Version 6 features, plus data compression and Unicode character encoding. Unicode encoding enables file sharing between systems that use different default character encoding schemes.
'-v6'	5 (R8) or later	Version 4 features, plus <i>N</i> -dimensional arrays, cell arrays and structures, and variable names greater than 19 characters.
'-v4'	all	Two-dimensional double, character, and sparse arrays.

If any data items require features that the specified version does not support, MATLAB does not save those items and issues a warning. You

cannot specify a version later than your current version of MATLAB software.

To view or set the default version for MAT-files, select a **MAT-file save format** option in the General Preferences.

## Examples

### Save All Workspace Variables to MAT-File

Save all variables from the workspace in a binary MAT-file, `test.mat`. If `filename` is a variable, you must use function syntax.

```
filename = 'test.mat';
save(filename)
```

Otherwise, you also can use command syntax.

```
save test.mat
```

Remove the variables from the workspace, and then retrieve the data with the `load` function.

```
clear
load('test.mat')
```

### Save Specific Variables to MAT-File

Create and save two variables, `p` and `q`, to a file called `pqfile.mat`.

```
p = rand(1,10);
q = ones(10);
save('pqfile.mat','p','q')
```

MATLAB saves the variables to the file, `pqfile.mat`, in the current folder.

You also can use command syntax to save the variables, `p` and `q`.

```
save pqfile.mat p q
```

## Save Data to ASCII File

Create two variables, save them to an ASCII file, and then view the contents of the file.

```
p = rand(1,10);
q = ones(10);
save('pqfile.txt','p','q','-ascii')
type('pqfile.txt')
```

The type function displays the contents of the file.

Alternatively, use command syntax for the save operation.

```
save pqfile.txt p q -ascii
```

## Save Structure Fields as Individual Variables

Create a structure, `s1`, that contains three fields, `a`, `b`, and `c`.

```
s1.a = 12.7;
s1.b = {'abc',[4 5; 6 7]};
s1.c = 'Hello!';
```

Save the fields of structure `s1` as individual variables in a file called `newstruct.mat`.

```
save('newstruct.mat','-struct','s1');
```

Check the contents of the file using the `whos` function.

```
disp('Contents of newstruct.mat:')
whos('-file','newstruct.mat')
```

```
Contents of newstruct.mat:
 Name Size Bytes Class Attributes
 a 1x1 8 double
 b 1x2 262 cell
```

```
c 1x6 12 char
```

## Save Variables to Version 7.3 MAT-File

Create two variables and save them to a version 7.3 MAT-file called `example.mat`.

```
A = rand(5);
B = magic(10);
save('example.mat', 'A', 'B', '-v7.3')
```

You also can use command syntax for the save operation.

```
save example.mat A B -v7.3
```

## Append Variable to MAT-File

Save two variables to a MAT-file. Then, append a third variable to the same file.

```
p = rand(1,10);
q = ones(10);
save('test.mat', 'p', 'q')
```

View the contents of the MAT-file.

```
whos('-file', 'test.mat')
```

Name	Size	Bytes	Class	Attributes
p	1x10	80	double	
q	10x10	800	double	

Create a new variable, `a`, and append it to the MAT-file.

```
a = 50;
save('test.mat', 'a', '-append')
```

View the contents of the MAT-file.

```
whos('-file', 'test.mat')
```

---

Name	Size	Bytes	Class	Attributes
a	1x1	8	double	
p	1x10	80	double	
q	10x10	800	double	

The variable, `a`, is appended to `test.mat`, without overwriting the previous variables, `p` and `q`.

---

**Note** To append to a Version 6 MAT-file, specify both `'-v6'` and `'-append'`. For example, to save variable `a` to the file, `test.mat`, call:

```
save('test.mat','a','-v6','-append')
```

---

## Tips

- For more flexibility in creating ASCII files, use `dlmwrite` or `fprintf`.

## See Also

`clear` | `hgsave` | `load` | `matfile` | `regexp` | `savesas` | `whos`

## Concepts

- “What Is the MATLAB Workspace?”
- “Save, Load, and Delete Workspace Variables”
- “Write to Delimited Data Files”
- “Regular Expressions”

# save (COM)

---

**Purpose** Serialize control object to file

**Syntax** `h.save('filename')`  
`save(h, 'filename')`

**Description** `h.save('filename')` saves the COM control object, `h`, to the file specified in the string, `filename`.  
`save(h, 'filename')` is an alternate syntax for the same operation.

---

**Note** The COM save function is only supported for controls at this time.

---

**Tips** COM functions are available on Microsoft Windows systems only.

**Examples** Create an `mwsamp` control and save its original state to the file `mwsample`:

```
f = figure('position', [100 200 200 200]);
h = actxcontrol('mwsamp.mwsampctrl.2', [0 0 200 200], f);
h.save('mwsample')
```

Now, alter the figure by changing its label and the radius of the circle:

```
h.Label = 'Circle';
h.Radius = 50;
h.Redraw;
```

Using the `load` function, you can restore the control to its original state:

```
h.load('mwsample');
h.get
```

MATLAB displays the original values:

```
ans =
 Label: 'Label'
 Radius: 20
```



**See Also**

load (COM) | actxcontrol | actxserver | release | delete (COM)

# save (serial)

---

**Purpose** Save serial port objects and variables to file

**Syntax** `save filename`  
`save filename obj1 obj2...`

**Description** `save filename` saves all MATLAB variables to the file `filename`. If an extension is not specified for `filename`, then the `.mat` extension is used.

`save filename obj1 obj2...` saves the serial port objects `obj1 obj2...` to the file `filename`.

**Tips** You can use `save` in the functional form as well as the command form shown above. When using the functional form, you must specify the filename and serial port objects as strings. For example, to save the serial port object `s` to the file `MySerial.mat` on a Windows platform

```
s = serial('COM1');
save('MySerial','s')
```

Any data that is associated with the serial port object is not automatically stored in the file. For example, suppose there is data in the input buffer for `obj`. To save that data to a file, you must bring it into the MATLAB workspace using one of the synchronous read functions, and then save to the file using a separate variable name. You can also save data to a text file with the `record` function.

You return objects and variables to the MATLAB workspace with the `load` command. Values for read-only properties are restored to their default values upon loading. For example, the `Status` property is restored to `closed`. To determine if a property is read-only, examine its reference pages.

**Examples** This example illustrates how to use the command and functional form of `save` on a Windows platform.

```
s = serial('COM1');
set(s,'BaudRate',2400,'StopBits',1)
save MySerial1 s
```

```
set(s, 'BytesAvailableFcn', @mycallback)
save('MySerial2', 's')
```

### See Also

[load](#) | [record](#) | [Status](#)

**Purpose** Save figure or Simulink block diagram using specified format

**Alternatives** Use **File > Save As** on the figure window menu to access the Save As dialog, in which you can select a graphics format. For details, see “Exporting in a Specific Graphics Format” in the MATLAB Graphics documentation. Sizes of files written to image formats by this GUI and by `saveas` can differ due to disparate resolution settings.

**Syntax**

```
saveas(h, 'filename.ext')
saveas(h, 'filename', 'format')
```

**Description** `saveas(h, 'filename.ext')` saves the figure or Simulink block diagram with the handle `h` to the file `filename.ext`. The format of the file is determined by the extension, `ext`. Allowable values for `ext` are listed in this table.

You can pass the handle of any Handle Graphics object to `saveas`, which then saves the parent figure to the object you specified should `h` not be a figure handle. This means that `saveas` cannot save a subplot without also saving all subplots in its parent figure.

Text Value	Format
ai	Adobe Illustrator '88 Support for this format will be removed in a future release.
bmp	Windows bitmap
emf	Enhanced metafile
eps	EPS Level 1
fig	MATLAB figure (invalid for Simulink block diagrams)
jpg	JPEG image (invalid for Simulink block diagrams)
m	MATLAB file (invalid for Simulink block diagrams)

Text Value	Format
pbm	Portable bitmap
pcx	Paintbrush 24-bit
pdf	Portable Document Format
pgm	Portable Graymap
png	Portable Network Graphics
ppm	Portable Pixmap
tif	TIFF image, compressed

`saveas(h, 'filename', 'format')` saves the figure or Simulink block diagram with the handle `h` to the file called `filename` using the specified `format`. The filename can have an extension, but the extension is not used to define the file format. If no extension is specified, the standard extension corresponding to the specified format is automatically appended to the filename.

Allowable values for `format` are the extensions in the table above and the device drivers and graphic formats supported by `print`. The drivers and graphic formats supported by `print` include additional file formats not listed in the table above. When using a `print` device type to specify format for `saveas`, do not prefix it with `-d`.

## Tips

You can use `open` to open files saved using `saveas` with an `m` or `fig` extension. Other `saveas` and `print` formats are not supported by `open`. Both the **Save As** and **Export Setup** dialog boxes that you access from a figure's **File** menu use `saveas` with the `format` argument, and support all device and file types listed above.

---

**Note** Whenever you specify a format for saving a figure with the **Save As** menu item, that file format is used again the next time you save that figure or a new one. If you do not want to save in the previously-used format, use **Save As** and be sure to set the **Save as type** drop-down menu to the kind of file you want to write. However, saving a figure with the `saveas` function and a format does not change the **Save as type** setting in the GUI.

---

If you want to control the size or resolution of figures saved in image (bit-mapped) formats, such as BMP or JPG, use the `print` command and specify dots-per-inch resolution with the `r` switch.

### Examples

#### Example 1: Specify File Extension

Save the current figure that you annotated using the Plot Editor to a file named `pred_pre` using the MATLAB `fig` format. This allows you to open the file `pred_pre.fig` at a later time and continue editing it with the Plot Editor.

```
saveas(gcf, 'pred_pre.fig')
```

#### Example 2: Specify File Format but No Extension

Save the current figure, using a Portable Document format, to the file `logo`. Use the `pdf` extension from the above table to specify the format. The file created is `logo.pdf`.

```
saveas(gcf, 'logo', 'pdf')
```

The file created is `logo.pdf`. MATLAB automatically appends the `pdf` extension because no extension was specified.

#### Example 3: Specify File Format and Extension

Save the current figure to the file `star.eps` using the Level 2 Color PostScript format. If you use `doc print` or `help print`, you can see from

the table for print device types that the device type for this format is `-dpsc2`. The file created is `star.eps`.

```
saveas(gcf, 'star.eps', 'psc2')
```

In another example, save the current Simulink block diagram to the file `trans.tiff` using the TIFF format with no compression. From the table for print device types, you can see that the device type for this format is `-dtiffn`. The file created is `trans.tiff`.

```
saveas(gcf, 'trans.tiff', 'tiffn')
```

#### **Example 4: Saving a Simulink Diagram**

Save a Simulink diagram from command line. The file is saved as `counters.bmp`

```
sldemo_tank
saveas(get_param('sldemo_tank', 'Handle'), 'topmodel.bmp');
```

Using `get_param`, get the handle of the model and save using the `saveas` command. The file can be saved in any desired standard image formats.

#### **See Also**

`hgsave` | `open` | `print` | `save_system`

# savefig

---

**Purpose** Save figure to FIG-file

**Syntax** `savefig(filename)`  
`savefig(h,filename)`

**Description** `savefig(filename)` saves the current figure to a FIG-file named `filename`.

`savefig(h,filename)` saves one or more figures referred to by `h`, where `h` can be a single figure handle or an array of figure handles.

## Input Arguments

**h - Handle to one or more figures**  
single figure handle | array of figure handles

Handle to one or more figures, specified as a single figure handle or an array of figure handles.

**filename - file name**  
'Untitled.fig' (default) | string

File name, specified as a string. If you do not specify a file name, then MATLAB saves the file as `Untitled.fig`, which is the default.

If the specified string does not include a `.fig` file extension, then MATLAB appends the extension. `savefig` does not accept other file extensions.

**Example:** 'ExampleFile.fig'

## Examples Save Current Figure to FIG-File

Create a surface plot of the peaks function. Save the figure to the file `PeaksFile.fig`. Close the figure after saving it.

```
figure;
surf(peaks);
savefig('PeaksFile.fig');
close(gcf)
```



To open the figure, use the command `openfig('PeaksFile.fig')`.

### Save Multiple Figures to FIG-File

Create two plots and store the figure handles in array `h`. Save the figures to the file `TwoFiguresFile.fig`. Close the figures after saving them.

```
h(1) = figure;
z = peaks;
surf(z)

h(2) = figure;
plot(z)

savefig(h, 'TwoFiguresFile.fig');
close(h)
```

To open the two figures, use the command `openfig('TwoFiguresFile.fig')`.

### Tips

- You must use MATLAB to open files saved using `savefig`. To open the file, pass the file name to the function `openfig`, `hgload`, or `open`. For example,

```
openfig('ExampleFile.fig')
```

opens the file, `ExampleFile.fig`, in MATLAB.

- `savefig` saves the full MATLAB figure. To save only part of a figure, such as an axes, or to save handles in addition to the data, use the `save` function to create a MAT-file.

### See Also

`openfig` | `save` | `open` | `load`

# saveobj

---

**Purpose** Modify save process for object

**Syntax** `b = saveobj(a)`

**Description** `b = saveobj(a)` is called by the `save` function if the class of `a` defines a `saveobj` method. `save` writes the returned value, `b`, to the MAT-file.

Define a `loadobj` method to take the appropriate action when loading the object.

If `A` is an array of objects, MATLAB invokes `saveobj` separately for each object saved.

**Examples** Call the superclass `saveobj` method from the subclass implementation of `saveobj` with the following syntax:

```
classdef mySub < super
 methods
 function subj = saveobj(obj)
 % Call superclass saveobj method
 subj = saveobj@super(obj);
 % Perform subclass save operations
 ...
 end
 ...
 end
 ...
end
```

See “Saving and Loading Objects from Class Hierarchies”.

---

Update object when saved:

```
function b = saveobj(a)
 % If the object does not have an account number,
 % Add account number to AccountNumber property
 if isempty(a.AccountNumber)
 a.AccountNumber = getAccountNumber(a);
 end
end
```

```
 end
 b = a;
end
```

See “Maintaining Class Compatibility”.

**See Also**

save | load | loadobj

**Tutorials**

- “Control Save and Load”

# savepath

---

<b>Purpose</b>	Save current search path
<b>Alternatives</b>	As an alternative to the <code>savepath</code> function, use the Set Path dialog box.
<b>Syntax</b>	<pre>savepath savepath folderName/pathdef.m status = savepath...</pre>
<b>Description</b>	<p><code>savepath</code> updates the MATLAB search path for all users on the system so that the path can be reused in a future session. <code>savepath</code> saves the search path to the <code>pathdef.m</code> file that MATLAB located at startup, or to the current folder if a <code>pathdef.m</code> file exists there. To save the search path programmatically each time you exit MATLAB, use <code>savepath</code> in a <code>finish.m</code> file.. On a Windows system with User Account Control (UAC) enabled, UAC might prompt you to allow the update operation because it requires administrator-level permission.</p> <p><code>savepath folderName/pathdef.m</code> saves the current search path to <code>pathdef.m</code> located in <code>folderName</code>. Use this form of the syntax if you do not have write access to the current <code>pathdef.m</code>. If you do not specify <code>folderName</code>, MATLAB saves <code>pathdef.m</code> in the current folder. <code>folderName</code> can be a relative or absolute path. To use the saved search path automatically in a future session, make <code>folderName</code> be the startup folder for MATLAB.</p> <p><code>status = savepath...</code> returns 0 when <code>savepath</code> was successful and 1 when <code>savepath</code> failed.</p>
<b>Examples</b>	<p>Save the current search path to <code>pathdef.m</code>, located in <code>I:/my_matlab_files</code>:</p> <pre>savepath I:/my_matlab_files/pathdef.m</pre>
<b>See Also</b>	<pre>addpath   cd   dir   finish   genpath   matlabroot   pathsep   pathtool   rehash   restoredefaultpath   rmpath   startup   userpath   what</pre>

**How To**

- “Running a Script When Exiting”
- “What Is the MATLAB Search Path?”

# scatter

---

**Purpose** Scatter plot

**Syntax**

```
scatter(X,Y)
scatter(X,Y,S)
scatter(X,Y,S,C)
scatter(__ , 'fill')
scatter(__ , markertype)
scatter(__ , Name, Value)

scatter(axes_handle, __)

h = scatter(__)
```

**Description** `scatter(X,Y)` displays circles at the locations specified by the vectors `X` and `Y`. This type of graph is also known as a bubble plot.

`scatter(X,Y,S)` draws each circle with the size specified by `S`. To plot each circle with equal size, specify `S` as a scalar. To plot each circle with a specific size, specify `S` as a vector with length equal to the length of `X` and `Y`.

`scatter(X,Y,S,C)` draws each circle with the color specified by `C`.

- If `C` is a color string or an RGB row vector, then all circles are plotted with the specified color.
- If `C` is a three column matrix with the number of rows in `C` equal to the length of `X` and `Y`, then each row of `C` specifies an RGB color value for the corresponding circle.
- If `C` is a vector with length equal to the length of `X` and `Y`, then the values in `C` are linearly mapped to the colors in the current colormap.

`scatter( __ , 'fill' )` fills in the circles, using any of the input argument combinations in the previous syntaxes.

`scatter( ___, markertype )` specifies the marker type.

`scatter( ___, Name, Value )` specifies scattergroup property settings using one or more Name, Value pair arguments.

`scatter( axes_handle, ___ )` plots into the axes specified by `axes_handle` instead of into the current axes (`gca`). The `axes_handle` option can precede any of the input argument combinations in the previous syntaxes.

`h = scatter( ___ )` returns the scattergroup object handle, `h`.

## Input Arguments

### **X - Value of data to display on x-axis**

vector

Value of data to display on the *x*-axis, specified as a vector. *X* and *Y* must be vectors of equal length.

#### **Data Types**

single | double | int8 | int16 | int32 | int64 | uint8 | uint16 | uint32 | uint64 | logical

### **Y - Value of data to display on y-axis**

vector

Value of data to display on the *y*-axis, specified as a vector. *X* and *Y* must be vectors of equal length.

#### **Data Types**

single | double | int8 | int16 | int32 | int64 | uint8 | uint16 | uint32 | uint64 | logical

### **S - Marker area**

36 (default) | scalar | row or column vector | []

Marker area, specified as a scalar, a row or column vector, or []. The values in *S* must be positive. The units for area are points squared.

# scatter

---

- If **S** is a scalar, then `scatter` plots all markers with the specified area.
- If **S** is a row or column vector, then each entry in **S** specifies the area for the corresponding marker. The length of **S** must equal the length of **X** and **Y**, and corresponding entries in **X**, **Y**, and **S** determine the location and area of each marker.
- If **S** is empty, then the default size of 36 points squared is used.

**Example:** 50

**Example:** [36,25,25,17,46]

## Data Types

single | double | int8 | int16 | int32 | int64 | uint8 |  
uint16 | uint32 | uint64 | logical

## C - Marker color

[0 0 1] (blue) (default) | color string | RGB row vector | three-column matrix of RGB values | vector

Marker color, specified as a color string, an RGB row vector, a three-column matrix of RGB values, or a vector. For an RGB row vector, use a three-element row vector whose elements specify the intensities of the red, green, and blue components of the color. The intensities must be in the range [0 1]. If you have three points in the scatter plot and want the colors to be indices into the colormap, specify **C** as a three-element column vector.

This table lists the predefined colors and their RGB equivalents.

RGB Vector	Short Name	Long Name
[1 1 0]	'y'	'yellow'
[1 0 1]	'm'	'magenta'
[0 1 1]	'c'	'cyan'
[1 0 0]	'r'	'red'
[0 1 0]	'g'	'green'



RGB Vector	Short Name	Long Name
[0 0 1]	'b'	'blue'
[1 1 1]	'w'	'white'
[0 0 0]	'k'	'black'

**Example:** 'k'

**Example:** [1,2,3,4]

**Example:** reshape([0,1,0,0,0,1,0.5,1,0.2],3,3)

### Data Types

single | double | int8 | int16 | int32 | int64 | uint8 |  
uint16 | uint32 | uint64 | logical | char

### markertype - Marker type

'o' (default) | string

Marker type, specified as a string. This table lists the supported marker types.

Specifier	Marker Type
'o'	Circle
'+'	Plus sign
'*'	Asterisk
'.'	Point
'x'	Cross
'square' or 's'	Square
'diamond' or 'd'	Diamond
'^'	Upward-pointing triangle
'v'	Downward-pointing triangle

Specifier	Marker Type
'>'	Right-pointing triangle
'<'	Left-pointing triangle
'pentagram' or 'p'	Five-pointed star (pentagram)
'hexagram' or 'h'	Six-pointed star (hexagram)
'none'	No marker

**Example:** 'p'

## Data Types

char

## axes\_handle - Axes handle

handle

Axes handle, which is the reference to an axes object. Use the `gca` function to get the handle to the current axes, for example, `axes_handle = gca;`

## Name-Value Pair Arguments

Specify optional comma-separated pairs of `Name`, `Value` arguments. `Name` is the argument name and `Value` is the corresponding value. `Name` must appear inside single quotes (' '). You can specify several name and value pair arguments in any order as `Name1,Value1,...,NameN,ValueN`.

**Example:** `'MarkerFaceColor','red'` sets the marker face color to red.

For more information on these settings see `scattergroup`.

## 'LineWidth' - Line width

0.5 (default) | scalar

Line width, specified as the comma-separated pair consisting of `'LineWidth'` and a scalar in points. The scalar sets the width size of the marker edge.

Example: 'LineWidth',0.75

### 'MarkerEdgeColor' - Marker edge color

'none' | 'auto' | 'flat' (default) | three-element RGB vector | string

Marker edge color, specified as the comma-separated pair consisting of 'MarkerEdgeColor' and a color value. The color value can be one of the supported strings or an RGB vector, listed in the following tables.

Specifier	Result
'flat'	Sets the color using the CData property.
'auto'	Sets the color to the axes Color property. If the axes Color property is none, then sets the color to the figure Color property.
'none'	Specifies no color, which makes nonfilled markers invisible.

For an RGB vector, use a three-element row vector whose elements specify the intensities of the red, green, and blue components of the color. The intensities must be in the range [0 1]. This table lists the predefined string colors and their RGB equivalents.

RGB Vector	Short Name	Long Name
[1 1 0]	'y'	'yellow'
[1 0 1]	'm'	'magenta'
[0 1 1]	'c'	'cyan'
[1 0 0]	'r'	'red'
[0 1 0]	'g'	'green'
[0 0 1]	'b'	'blue'

RGB Vector	Short Name	Long Name
[1 1 1]	'w'	'white'
[0 0 0]	'k'	'black'

**Example:** `'MarkerEdgeColor',[1 .8 .1]`

### 'MarkerFaceColor' - Marker face color

'none' (default) | 'auto' | 'flat' | three-element RGB vector | string

Marker face color, specified as the comma-separated pair consisting of 'MarkerFaceColor' and a color value. MarkerFaceColor sets the fill color for markers that are closed shapes (circle, square, diamond, pentagram, hexagram, and the four triangles). The color value can be one of the supported strings or an RGB vector, listed in the following tables.

Specifier	Result
'flat'	Sets the fill color using the CData property.
'auto'	Sets the fill color to the axes Color property. If the axes Color property is none, then sets the fill color to the figure Color property.
'none'	Makes the interior of the marker transparent, allowing the background to show through.

For an RGB vector, use a three-element row vector whose elements specify the intensities of the red, green, and blue components of the color. The intensities must be in the range [0 1]. This table lists the predefined string colors and their RGB equivalents.

RGB Vector	Short Name	Long Name
[1 1 0]	'y'	'yellow'
[1 0 1]	'm'	'magenta'
[0 1 1]	'c'	'cyan'
[1 0 0]	'r'	'red'
[0 1 0]	'g'	'green'
[0 0 1]	'b'	'blue'
[1 1 1]	'w'	'white'
[0 0 0]	'k'	'black'

**Example:** 'MarkerFaceColor',[0 .8 1]

## Output Arguments

### **h - Scattergroup object handle**

scalar

Scattergroup object handle, returned as a scalar. This is a unique identifier, which you can use to query and modify the properties of the scattergroup object.

## Examples

### **Create Scatter Plot**

Define  $x$  to contain 200 equally spaced values between 0 and  $3\pi$ . Initialize the random-number generator to make the output of `rand` repeatable, and define  $y$  to contain cosine values with random noise.

```
x = linspace(0,3*pi,200);
rng(0,'twister');
y = cos(x)+ rand(1,200);
```

Create a scatter plot using the two vector inputs.

```
figure
scatter(x,y)
```

## scatter

---

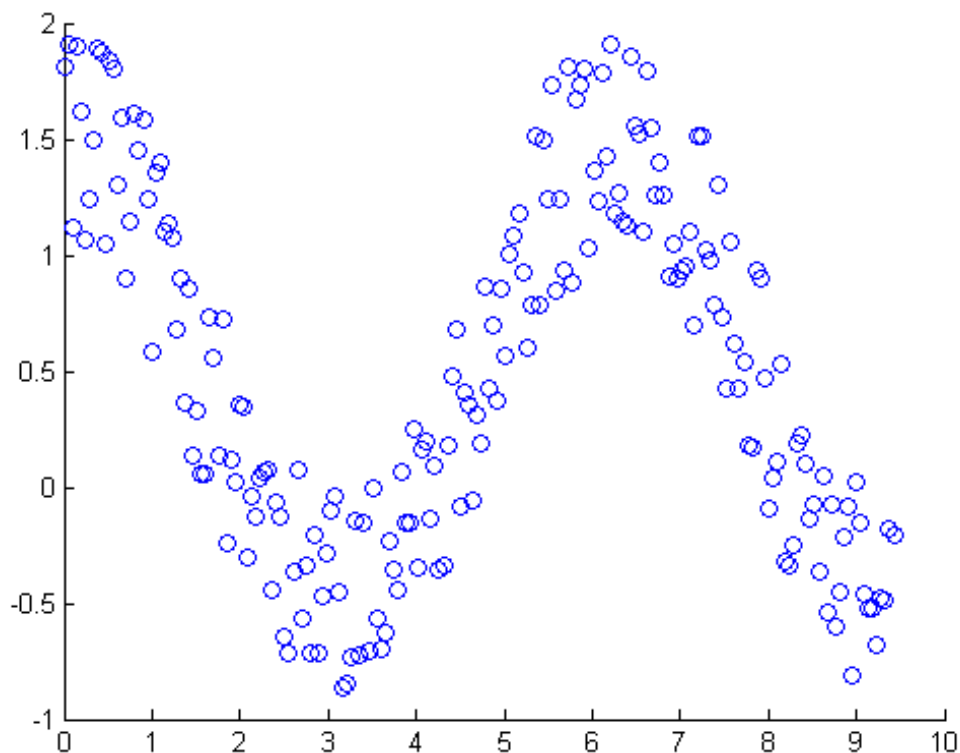

scatter plots entries in  $x$  against corresponding entries in  $y$ .

### **Vary Circle Size**

Load the sample data from `seamount` to get vectors  $x$  and  $y$ . Define  $s$  as a vector of linearly spaced values between 1 and 50 that is the same length as  $x$ . Create a scatter plot and vary the circle size. Use `zoom` to zoom in on the scatter plot.

figure

```
load seamount
s = linspace(1,50,length(x));
scatter(x,y,s)
zoom(2)
```

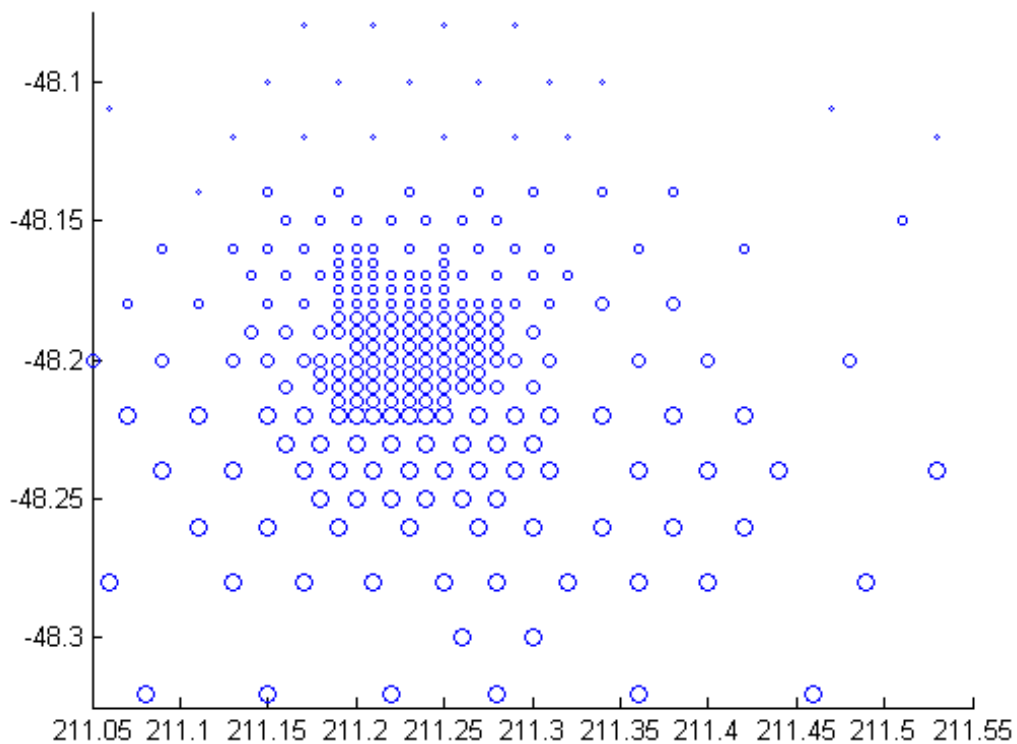

Corresponding entries in  $x$ ,  $y$ , and  $s$  determine the location and size of each marker.

## Vary Circle Color

Load the sample data from `seamount` to get vectors `x` and `y`. Define `c` as a vector of linearly spaced values between 1 and 10 that is the same length as `x`. Create a scatter plot and vary the circle color. Use `zoom` to zoom in on the scatter plot.

```
figure
load seamount
s = 10;
c = linspace(1,10,length(x));
scatter(x,y,s,c)
zoom(2)
```



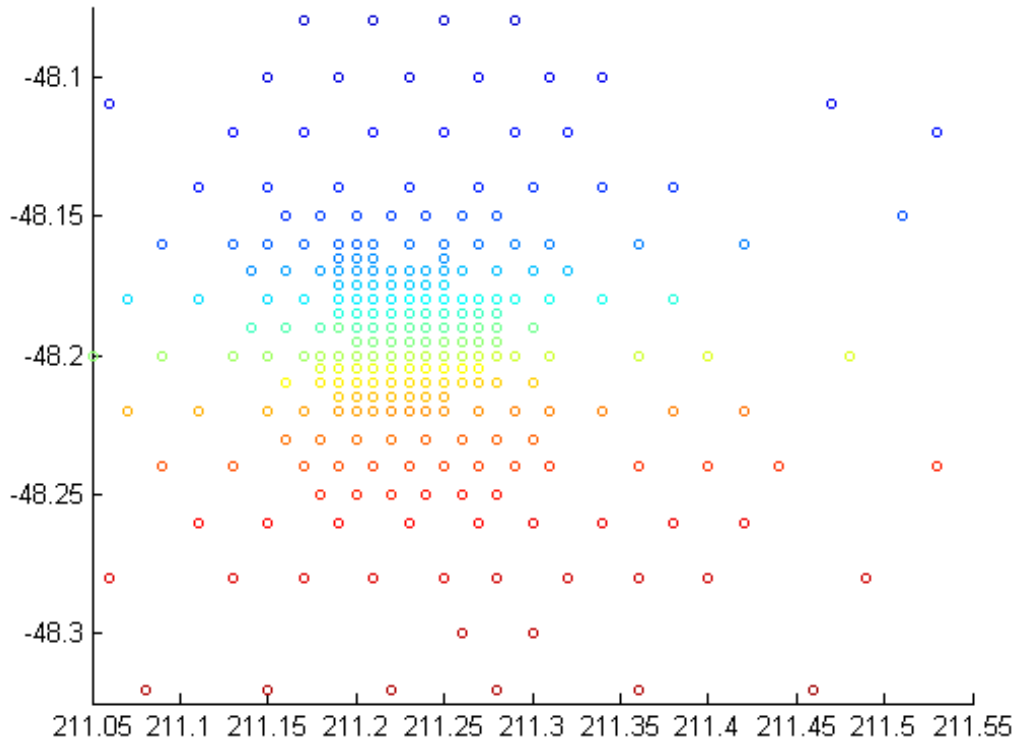

Corresponding entries in `x`, `y`, and `c` determine the location and color of each marker. Since `s` is a scalar value, all markers are the same size.

### Vary Circle Size and Color

Load sample data from `seamount` to get vectors `x`, `y`, and `z`. Create a scatter plot and vary the circle size and color. Fill in the circles and use `zoom` to zoom in on the scatter plot.

`figure`

# scatter

```
load seamount
s = sqrt(-z/2);
c = z;
scatter(x,y,s,c,'fill')
zoom(2)
```

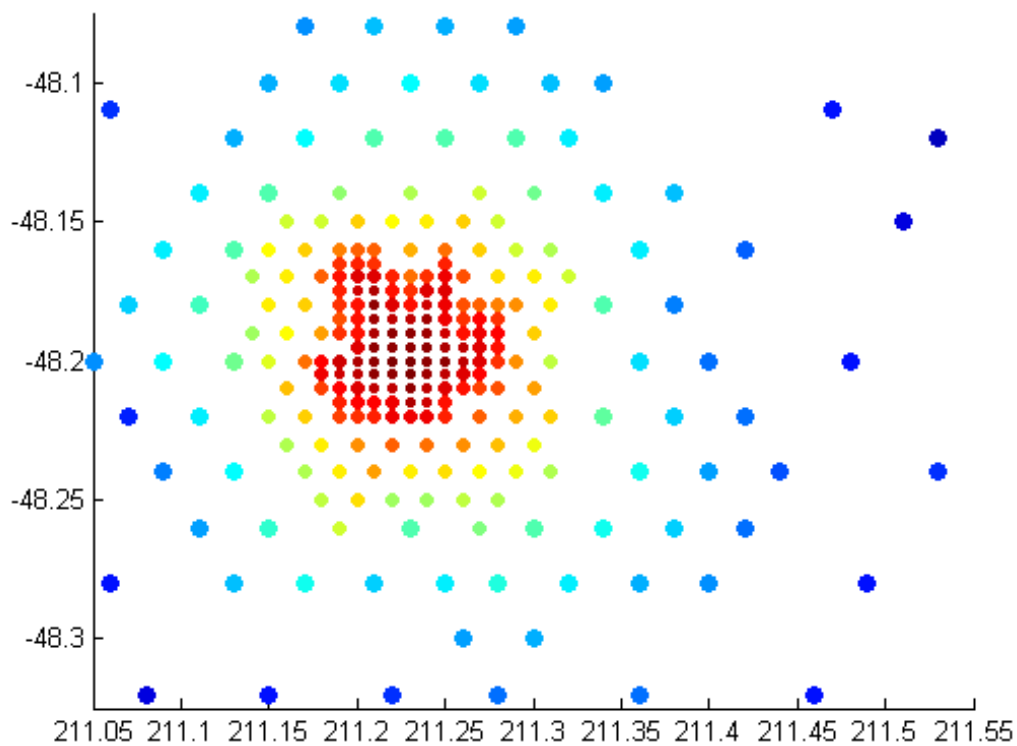

scatter plots each circle with a specific size and color determined by the vectors  $s$  and  $c$ , respectively.

### **Specify Marker Symbol**

Initialize the random-number generator to make the output of rand repeatable. Set up vectors x and y as sine and cosine values with random noise.

```
rng(0, 'twister');
theta = linspace(0, 2*pi, 150);
x = sin(theta) + 0.75*rand(1, 150);
y = cos(theta) + 0.75*rand(1, 150);
```

Create a scatter plot and set the marker type to diamonds with an area of 140 points squared.

```
figure
s = 140;
scatter(x, y, s, 'd')
```

## scatter

---

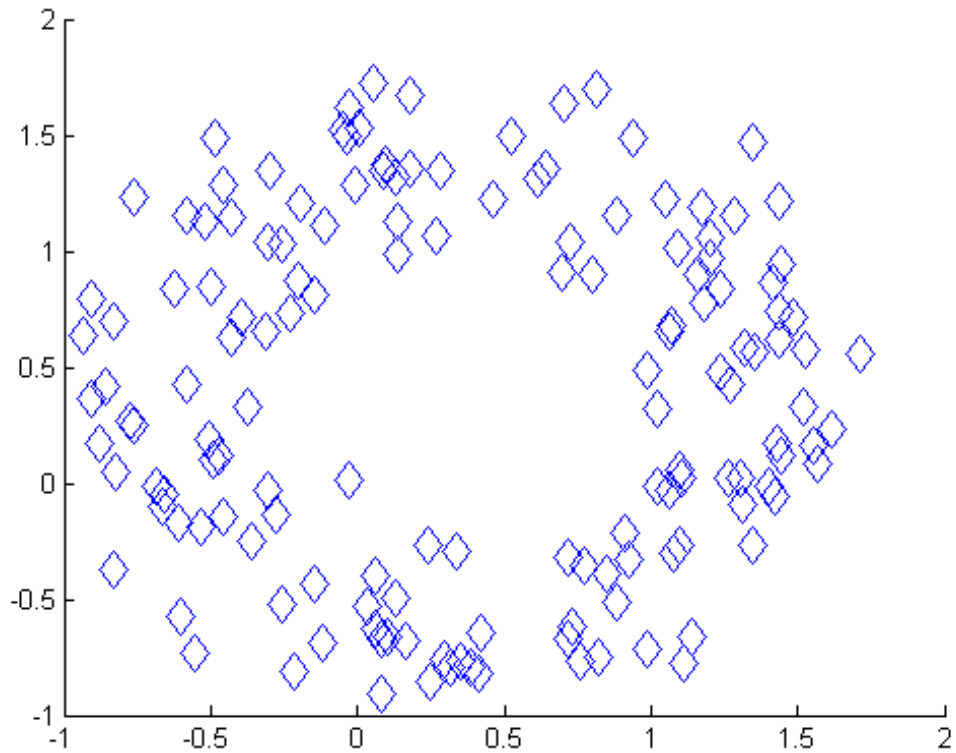

To fill in the diamonds, use the 'fill' option.

### **Specify Marker Properties**

Initialize the random-number generator to make the output of rand repeatable. Define vectors x and y as sine and cosine values with random noise.

```
rng(0,'twister');
theta = linspace(0,2*pi,300);
```

```
x = sin(theta) + 0.75*rand(1,300);
y = cos(theta) + 0.75*rand(1,300);
```

Create a scatter plot and set the marker size, edge color, face color, and line width using Name,Value pair arguments.

```
figure
s = 40;
scatter(x,y,s,'MarkerEdgeColor','b',...
 'MarkerFaceColor','c',...
 'LineWidth',1.5)
```

## scatter

---

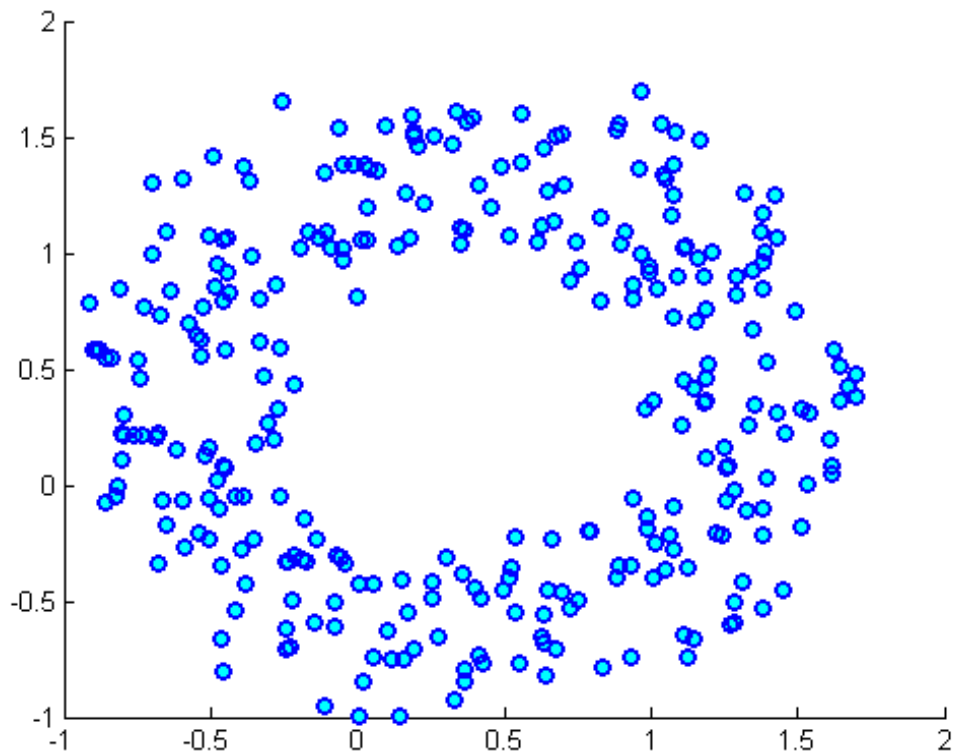

### Specify Scatter Plot Axes

Load the sample data from `seamount` to get vectors `x`, `y`, and `z`.

```
load seamount
```

Create a figure with two subplots and return the handles to the two subplot axes in array `hs`. Create a scatter plot in the upper subplot using the axes handle, `hs(1)`. In the lower subplot, create another scatter plot from the same data sample and use filled, diamond markers.

```
figure
hs(1) = subplot(1,2,1);
hs(2) = subplot(1,2,2);
s = 30;
c = z;
scatter(hs(1),x,y,s,c)
scatter(hs(2),x,y,s,c,'fill','d')
```

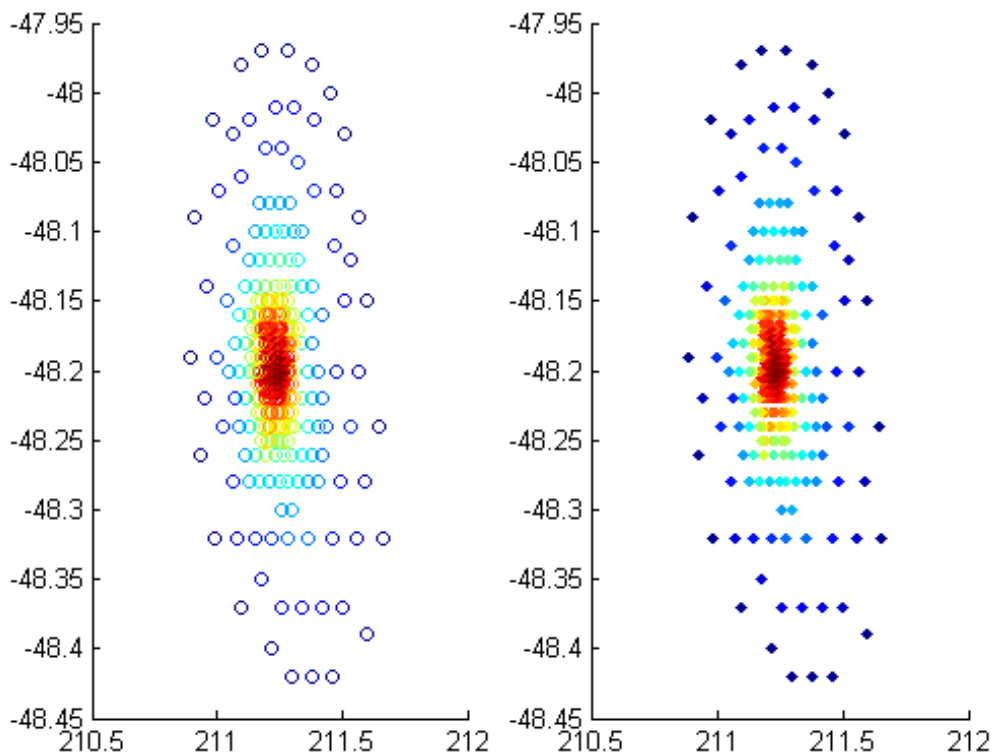

## Set Marker Properties Using the Handle

Use `|sphere|` to define vectors `|x|`, `|y|`, and `|z|`.

```
[X,Y,Z] = sphere(16);
x = [0.5*X(:); 0.75*X(:); X(:)];
y = [0.5*Y(:); 0.75*Y(:); Y(:)];
z = [0.5*Z(:); 0.75*Z(:); Z(:)];
```

Define vectors `s` and `c` to specify the size and color for each marker.

```
S = repmat([70,50,20],numel(X),1);
C = repmat([1,2,3],numel(X),1);
s = S(:);
c = C(:);
```

Create a 3-D scatter plot and return the scattergroup handle, `h`.

```
figure
h = scatter3(x,y,z,s,c);
```



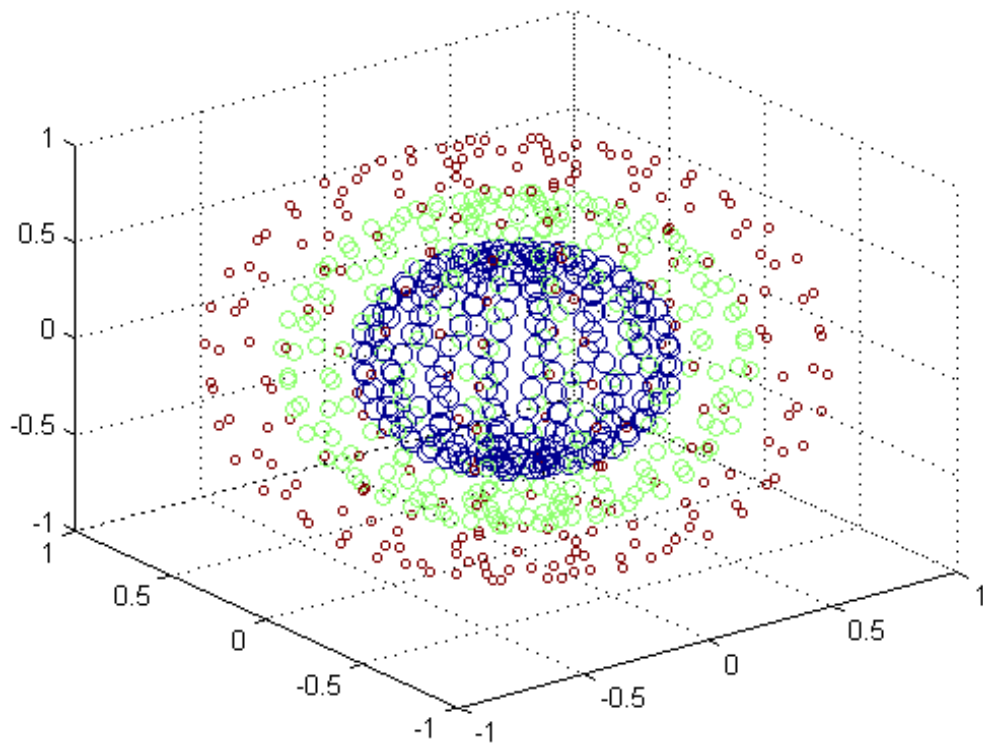

Use the handle to set the marker face color for the scatter plot.

```
set(h, 'MarkerFaceColor', [0 .5 .5])
```

## scatter

---

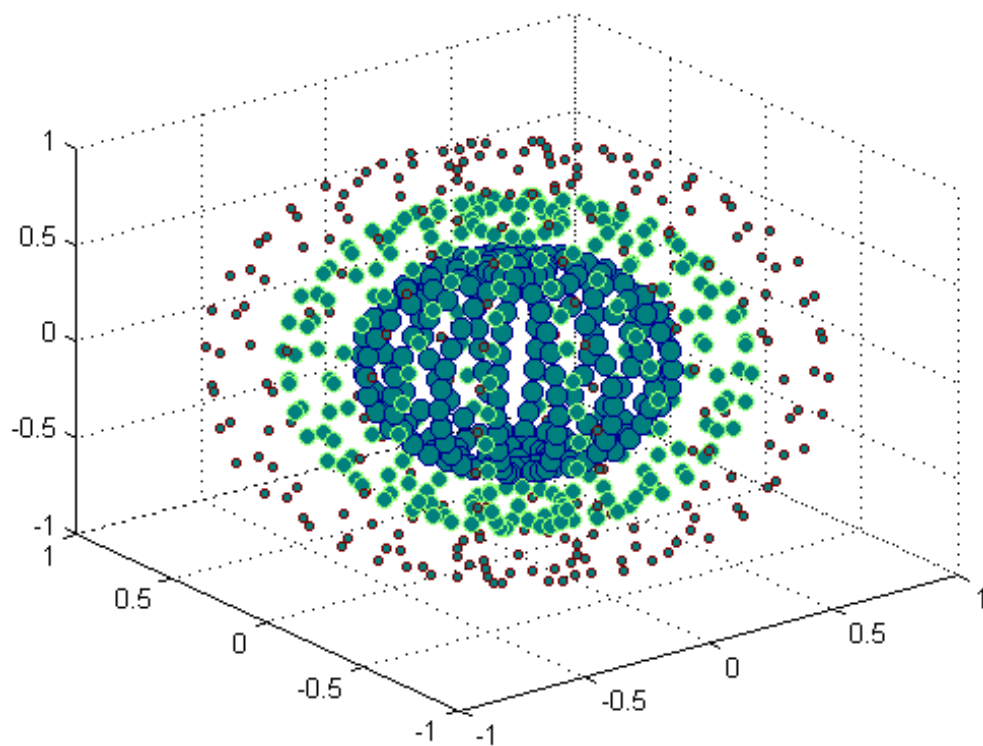

### See Also

[scatter3](#) | [plot3](#) | [scattergroup](#) | [ColorSpec](#) | [LineStyle](#)

**Purpose**

3-D scatter plot

**Syntax**

```
scatter3(X,Y,Z)
scatter3(X,Y,Z,S)
scatter3(X,Y,Z,S,C)
scatter3(__ , 'fill')
scatter3(__ , markertype)
scatter3(__ , Name, Value)

scatter3(axes_handle, __)

h = scatter3(__)
```

**Description**

`scatter3(X,Y,Z)` displays circles at the locations specified by the vectors *X*, *Y*, and *Z*.

`scatter3(X,Y,Z,S)` draws each circle with the size specified by *S*. To plot each circle with equal size, specify *S* as a scalar. To plot each circle with a specific size, specify *S* as a vector.

`scatter3(X,Y,Z,S,C)` draws each circle with the color specified by *C*.

- If *C* is a color string or an RGB row vector, then all circles are plotted with the specified color.
- If *C* is a three column matrix with the number of rows in *C* equal to the length of *X*, *Y*, and *Z*, then each row of *C* specifies an RGB color value for the corresponding circle.
- If *C* is a vector with length equal to the length of *X*, *Y*, and *Z*, then the values in *C* are linearly mapped to the colors in the current colormap.

`scatter3( __ , 'fill' )` fills in the circles, using any of the input argument combinations in the previous syntaxes.

`scatter3( __ , markertype)` specifies the marker type.

# scatter3

---

`scatter3( ___, Name, Value)` specifies scattergroup property settings using one or more `Name, Value` pair arguments.

`scatter3(axes_handle, ___)` plots into the axes specified by `axes_handle` instead of into the current axes (`gca`). The `axes_handle` option can precede any of the input argument combinations in the previous syntaxes.

`h = scatter3( ___)` returns the scattergroup object handle, `h`.

## Input Arguments

### **X - Value of data to display on x-axis**

vector

Value of data to display on the *x*-axis, specified as a vector. *X*, *Y*, and *Z* must be vectors of equal length.

#### **Data Types**

single | double | int8 | int16 | int32 | int64 | uint8 | uint16 | uint32 | uint64 | logical

### **Y - Value of data to display on y-axis**

(default) | vector

Value of data to display on the *y*-axis, specified as a vector. *X*, *Y*, and *Z* must be vectors of equal length.

#### **Data Types**

single | double | int8 | int16 | int32 | int64 | uint8 | uint16 | uint32 | uint64 | logical

### **Z - Value of data to display on z-axis**

(default) | vector

Value of data to display on the *z*-axis, specified as a vector. *X*, *Y*, and *Z* must be vectors of equal length.

#### **Data Types**

single | double | int8 | int16 | int32 | int64 | uint8 | uint16 | uint32 | uint64 | logical

**S - Marker area**

36 (default) | scalar | vector | []

Marker area, specified as a scalar, a vector, or []. The values in S must be positive. The units for area are points squared.

- If S is a scalar, then scatter3 plots all markers with the specified area.
- If S is a row or column vector, then each entry in S specifies the area for the corresponding marker. The length of S must equal the length of X, Y and Z. Corresponding entries in X, Y, Z and S determine the location and area of each marker.
- If S is empty, then the default size of 36 points squared is used.

**Example:** 50

**Example:** [36,25,25,17,46]

**Data Types**

single | double | int8 | int16 | int32 | int64 | uint8 |  
uint16 | uint32 | uint64 | logical

**C - Marker color**

[0 0 1] (blue) (default) | color string | RGB row vector | three-column  
matrix of RGB values | vector

Marker color, specified as a color string, an RGB row vector, a three-column matrix of RGB values, or a vector. For an RGB row vector, use a three-element row vector whose elements specify the intensities of the red, green, and blue components of the color. The intensities must be in the range [0 1]. If you have three points in the scatter plot and want the colors to be indices into the colormap, specify C as a three-element column vector.

This table lists the predefined colors and their RGB equivalents.

# scatter3

RGB Vector	Short Name	Long Name
[1 1 0]	'y'	'yellow'
[1 0 1]	'm'	'magenta'
[0 1 1]	'c'	'cyan'
[1 0 0]	'r'	'red'
[0 1 0]	'g'	'green'
[0 0 1]	'b'	'blue'
[1 1 1]	'w'	'white'
[0 0 0]	'k'	'black'

**Example:** 'y'

**Example:** [1,2,3,4]

**Example:** reshape([0,1,0,0,0,1,0.5,1,0.2],3,3)

## Data Types

single | double | int8 | int16 | int32 | int64 | uint8 |  
uint16 | uint32 | uint64 | logical

## markertype - Marker type

'o' (default) | string

Marker type, specified as a string. The table below lists the supported marker types.

Specifier	Marker Type
'o'	Circle
'+'	Plus sign
'*'	Asterisk
'.'	Point
'x'	Cross

Specifier	Marker Type
'square' or 's'	Square
'diamond' or 'd'	Diamond
'^'	Upward-pointing triangle
'v'	Downward-pointing triangle
'>'	Right-pointing triangle
'<'	Left-pointing triangle
'pentagram' or 'p'	Five-pointed star (pentagram)
'hexagram' or 'h'	Six-pointed star (hexagram)
'none'	No marker

### **axes\_handle - Axes handle**

handle

Axes handle, which is the reference to an axes object. Use the `gca` function to get the handle to the current axes, for example, `axes_handle = gca;`

### **Name-Value Pair Arguments**

Specify optional comma-separated pairs of `Name`, `Value` arguments. `Name` is the argument name and `Value` is the corresponding value. `Name` must appear inside single quotes (' '). You can specify several name and value pair arguments in any order as `Name1, Value1, ..., NameN, ValueN`.

**Example:** `'MarkerFaceColor', 'red'` sets the marker face color to red.

For more information on these properties see `scattergroup`.

### **'LineWidth' - Line width**

0.5 (default) | scalar

Line width, specified as the comma-separated pair consisting of 'LineWidth' and a scalar. The scalar sets the width size in points of the marker edge.

**Example:** 'LineWidth',0.75

### 'MarkerEdgeColor' - Marker edge color

'none' | 'auto' | 'flat' (default) | three-element RGB vector | string

Marker edge color, specified as the comma-separated pair consisting of 'MarkerEdgeColor' and a color value. The color value can be one of the supported strings or an RGB vector, listed in the following tables.

Specifier	Result
'flat'	Sets the color using the CData property.
'auto'	Sets the color to the axes Color property. If the axes Color property is none, then sets the color to the figure Color property.
'none'	Specifies no color, which makes nonfilled markers invisible.

For an RGB vector, use a three-element row vector whose elements specify the intensities of the red, green, and blue components of the color. The intensities must be in the range [0 1]. This table lists the predefined string colors and their RGB equivalents.

RGB Vector	Short Name	Long Name
[1 1 0]	'y'	'yellow'
[1 0 1]	'm'	'magenta'
[0 1 1]	'c'	'cyan'
[1 0 0]	'r'	'red'



RGB Vector	Short Name	Long Name
[0 1 0]	'g'	'green'
[0 0 1]	'b'	'blue'
[1 1 1]	'w'	'white'
[0 0 0]	'k'	'black'

**Example:** 'MarkerEdgeColor',[1 .8 .1]

### 'MarkerFaceColor' - Marker face color

'none' (default) | 'auto' | 'flat' | three-element RGB vector | string

Marker face color, specified as the comma-separated pair consisting of 'MarkerFaceColor' and a color value. MarkerFaceColor sets the fill color for markers that are closed shapes (circle, square, diamond, pentagram, hexagram, and the four triangles). The color value can be one of the supported strings or an RGB vector, listed in the following tables.

Specifier	Result
'flat'	Sets the fill color using the CData property.
'auto'	Sets the fill color to the axes Color property. If the axes Color property is none, then sets the fill color to the figure Color property.
'none'	Makes the interior of the marker transparent, allowing the background to show through.

For an RGB vector, use a three-element row vector whose elements specify the intensities of the red, green, and blue components of the color. The intensities must be in the range [0 1]. This table lists the predefined string colors and their RGB equivalents.

# scatter3

RGB Vector	Short Name	Long Name
[1 1 0]	'y'	'yellow'
[1 0 1]	'm'	'magenta'
[0 1 1]	'c'	'cyan'
[1 0 0]	'r'	'red'
[0 1 0]	'g'	'green'
[0 0 1]	'b'	'blue'
[1 1 1]	'w'	'white'
[0 0 0]	'k'	'black'

**Example:** 'MarkerFaceColor',[0 .8 1]

## Output Arguments

### **h** - Scattergroup object handle

scalar

Scattergroup object handle, returned as a scalar. This is a unique identifier, which you can use to query and modify the properties of the scattergroup.

## Examples

### **Create 3-D Scatter Plot**

Create a 3-D scatter plot. Use sphere to define vectors x, y, and z.

```
figure
[X,Y,Z] = sphere(16);
x = [0.5*X(:); 0.75*X(:); X(:)];
y = [0.5*Y(:); 0.75*Y(:); Y(:)];
z = [0.5*Z(:); 0.75*Z(:); Z(:)];
scatter3(x,y,z)
```

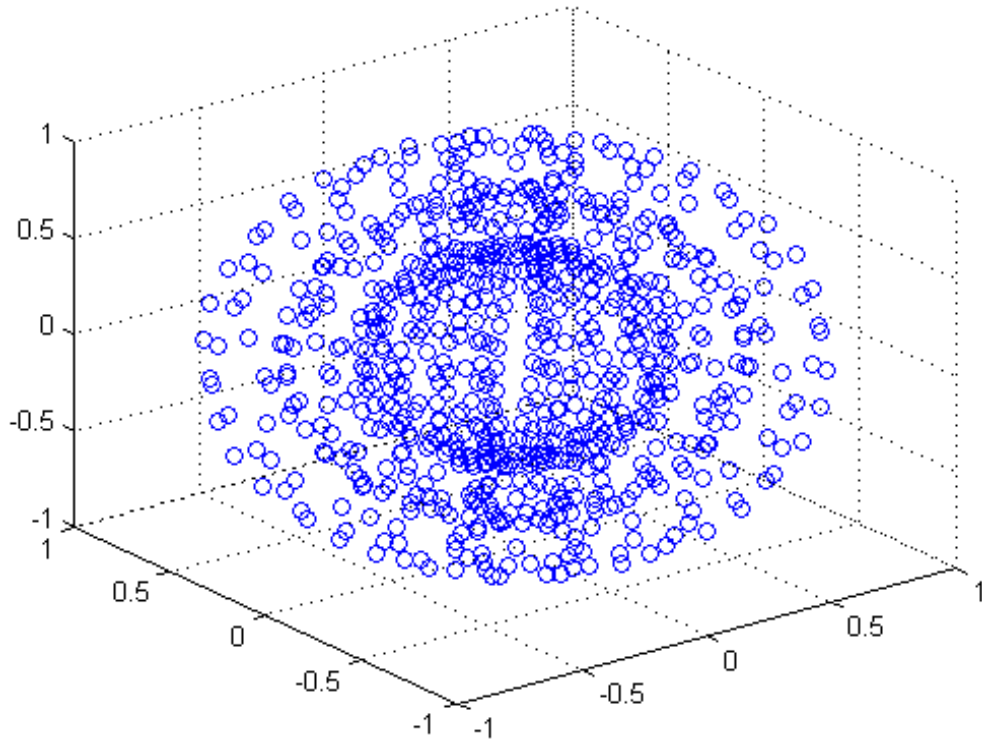

### Vary Marker Size

Use `sphere` to define vectors `x`, `y`, and `z`.

```
[X,Y,Z] = sphere(16);
x = [0.5*X(:); 0.75*X(:); X(:)];
y = [0.5*Y(:); 0.75*Y(:); Y(:)];
z = [0.5*Z(:); 0.75*Z(:); Z(:)];
```

Define vector `s` to specify the marker sizes.

## scatter3

---

```
S = repmat([100,50,5],numel(X),1);
s = S(:);
```

Create a 3-D scatter plot and use `view` to change the angle of the axes in the figure.

```
figure
scatter3(x,y,z,s)
view(40,35)
```

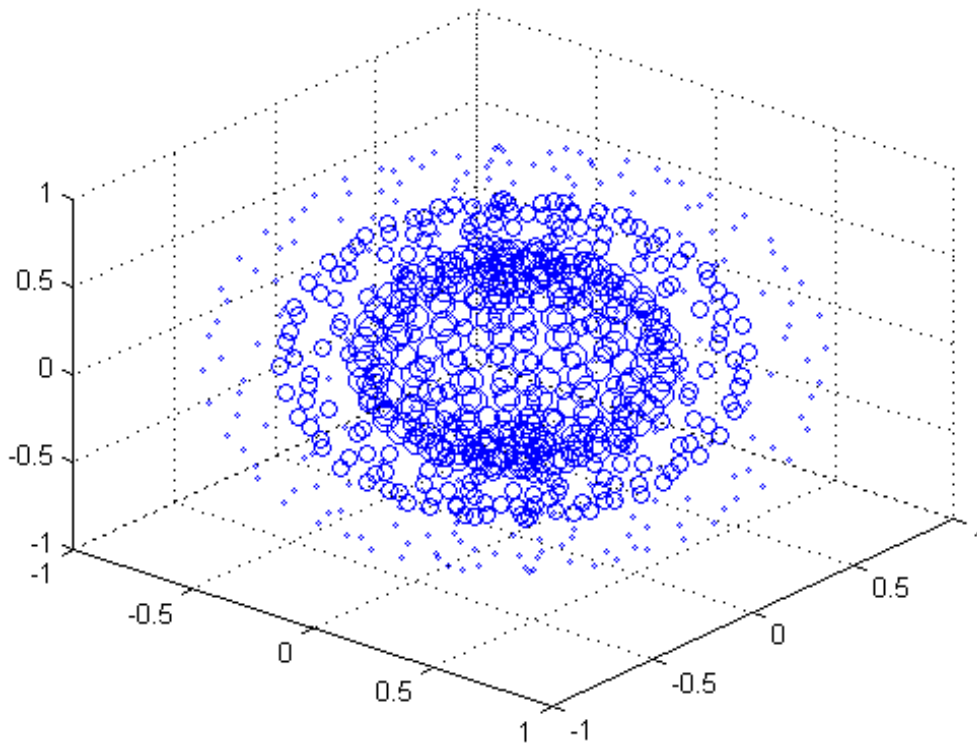

Corresponding entries in `x`, `y`, `z`, and `s` determine the location and size of each marker.

### Vary Marker Color

Use `sphere` to define vectors `x`, `y`, and `z`.

```
[X,Y,Z] = sphere(16);
x = [0.5*X(:); 0.75*X(:); X(:)];
y = [0.5*Y(:); 0.75*Y(:); Y(:)];
z = [0.5*Z(:); 0.75*Z(:); Z(:)];
```

Define vectors `s` and `c` to specify the size and color of each marker.

```
S = repmat([50,25,10], numel(X), 1);
C = repmat([1,2,3], numel(X), 1);
s = S(:);
c = C(:);
```

Create a 3-D scatter plot and use `view` to change the angle of the axes in the figure.

```
figure
scatter3(x,y,z,s,c)
view(40,35)
```

## scatter3

---

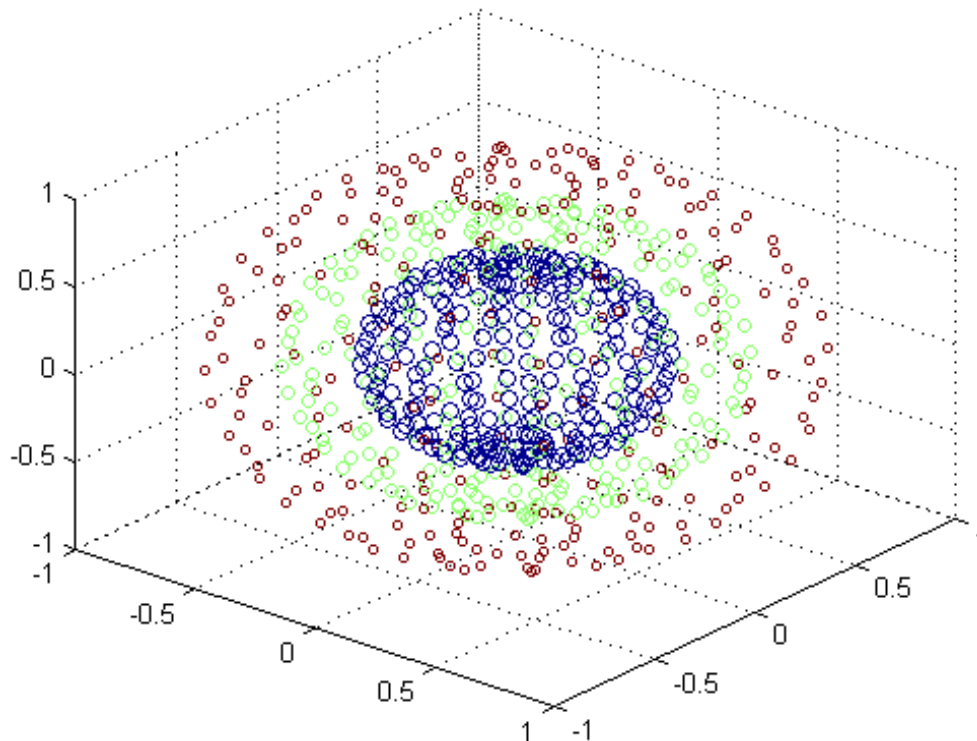

Corresponding entries in  $x$ ,  $y$ ,  $z$ , and  $c$  determine the location and color of each marker.

### Fill in Markers

Initialize the random-number generator to make the output of `rand` repeatable. Define vectors  $x$  and  $y$  as cosine and sine values with random noise.

```
rng(0, 'twister');
```

```
z = linspace(0,4*pi,250);
x = 2*cos(z) + rand(1,250);
y = 2*sin(z) + rand(1,250);
```

Create a 3-D scatter plot and fill in the markers. Use `view` to change the angle of the axes in the figure.

```
figure
scatter3(x,y,z,'fill')
view(-30,10)
```

## scatter3

---

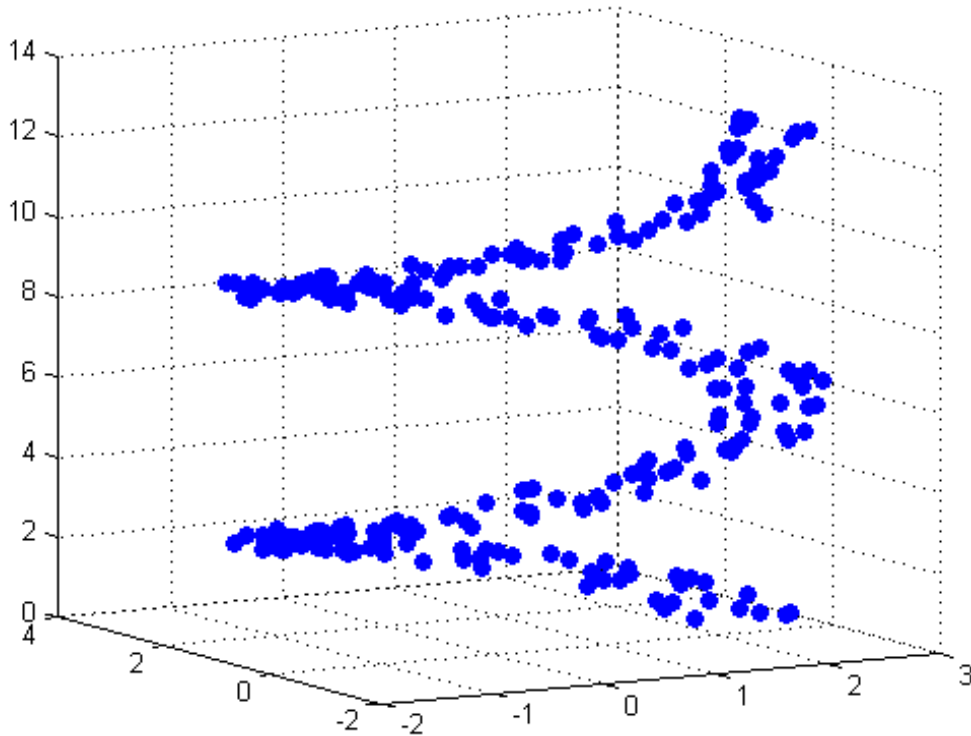

### Set Marker Type

Initialize the random-number generator to make the output of `rand` repeatable. Define vectors `x` and `y` as cosine and sine values with random noise.

```
rng(0,'twister');
z = linspace(0,4*pi,250);
x = 2*cos(z) + rand(1,250);
y = 2*sin(z) + rand(1,250);
```



Create a 3-D scatter plot and set the marker type. Use `view` to change the angle of the axes in the figure.

```
figure
scatter3(x,y,z, '*')
view(-30,10)
```

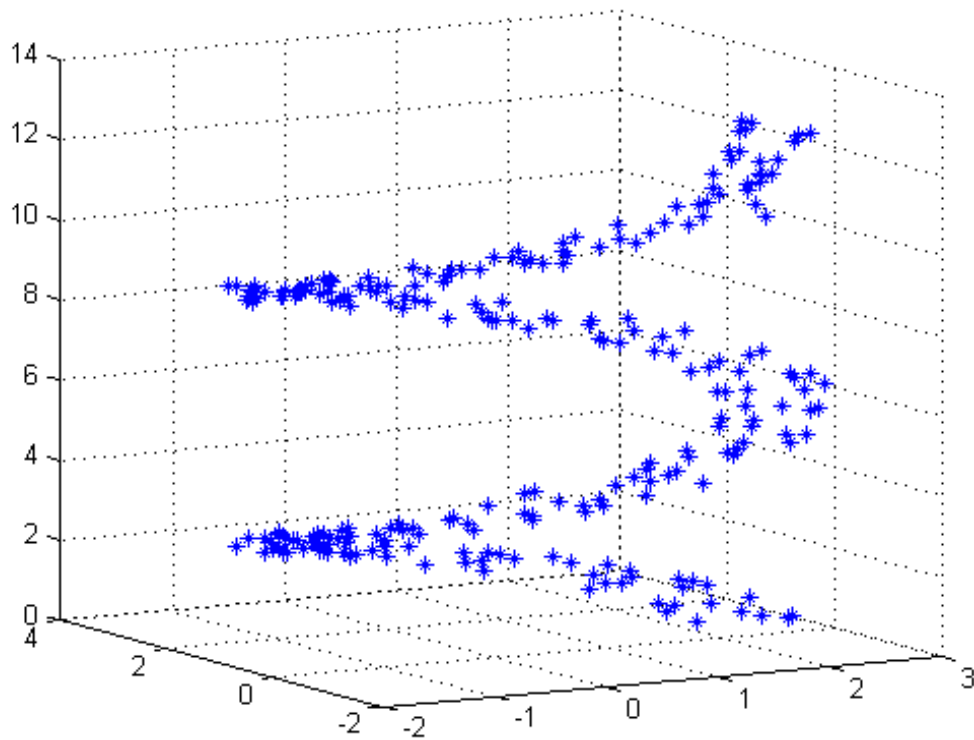

## Set Marker Properties

Initialize the random-number generator to make the output of `rand` repeatable. Define vectors `x` and `y` as cosine and sine values with random noise.

```
rng(0, 'twister');
z = linspace(0,4*pi,250);
x = 2*cos(z) + rand(1,250);
y = 2*sin(z) + rand(1,250);
```

Create a 3-D scatter plot and set the marker edge color and the marker face color. Use `view` to change the angle of the axes in the figure.

```
figure
scatter3(x,y,z,...
 'MarkerEdgeColor','k',...
 'MarkerFaceColor',[0 .75 .75])
view(-30,10)
```

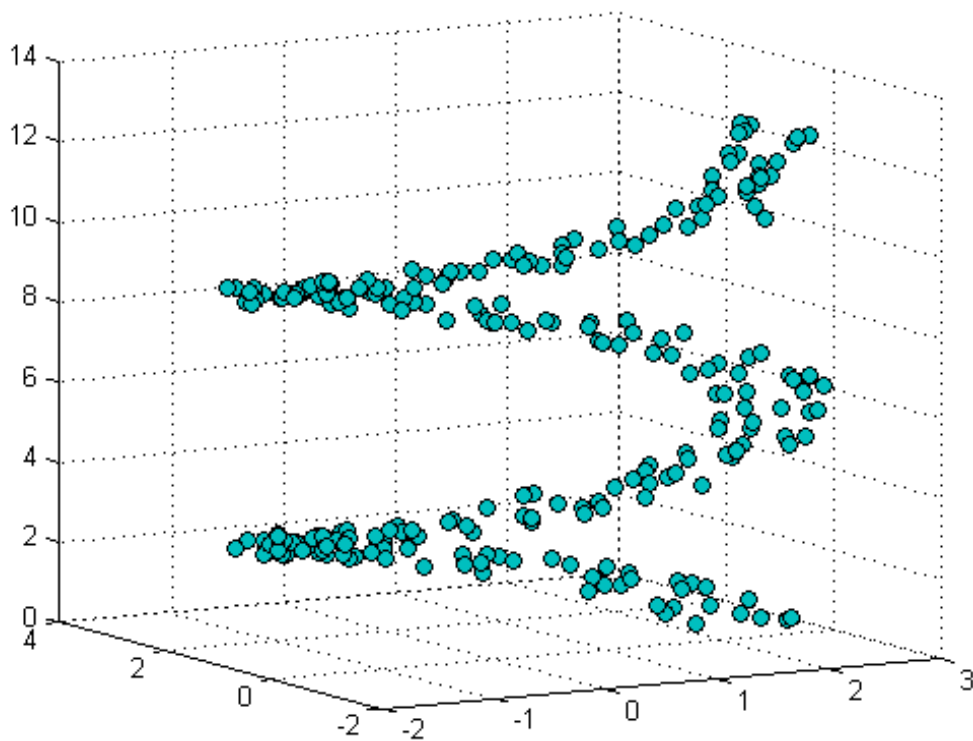

### Specify Axes for 3-D Scatter Plot

Load the seamount data set to get vectors  $x$ ,  $y$ , and  $z$ .

```
load seamount
```

Create a figure with two subplots and return the handles to the two axes in array  $hs$ . In each subplot, create a 3-D scatter plot. Specify the marker properties for each scatter plot.

# scatter3

```
figure
hs(1) = subplot(2,1,1);
hs(2) = subplot(2,1,2);
scatter3(hs(1),x,y,z,'MarkerFaceColor',[0 .75 .75])
scatter3(hs(2),x,y,z,'*')
```

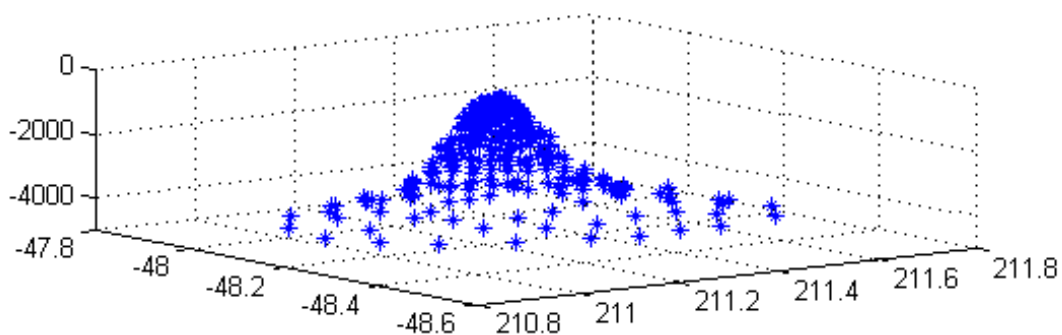
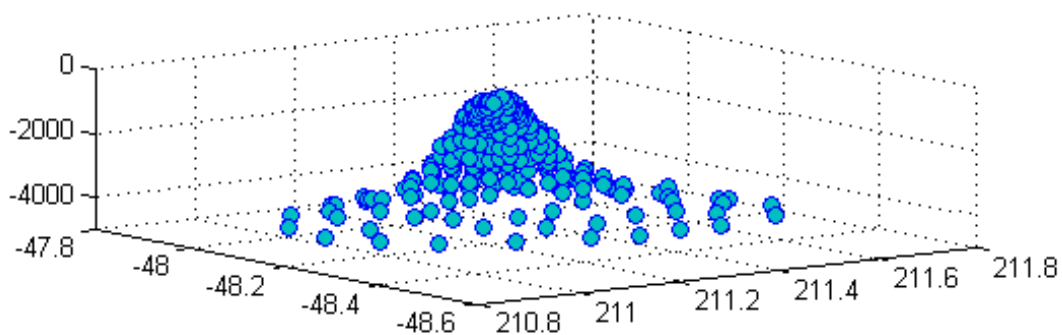

## Set Marker Properties Using the Handle

Use `|sphere|` to define vectors `|x|`, `|y|`, and `|z|`.

```
[X,Y,Z] = sphere(16);
x = [0.5*X(:); 0.75*X(:); X(:)];
y = [0.5*Y(:); 0.75*Y(:); Y(:)];
z = [0.5*Z(:); 0.75*Z(:); Z(:)];
```

Define vectors **s** and **c** to specify the size and color for each marker.

```
S = repmat([70,50,20], numel(X), 1);
C = repmat([1,2,3], numel(X), 1);
s = S(:);
c = C(:);
```

Create a 3-D scatter plot and return the scattergroup handle, **h**.

```
figure
h = scatter3(x,y,z,s,c);
```

## scatter3

---

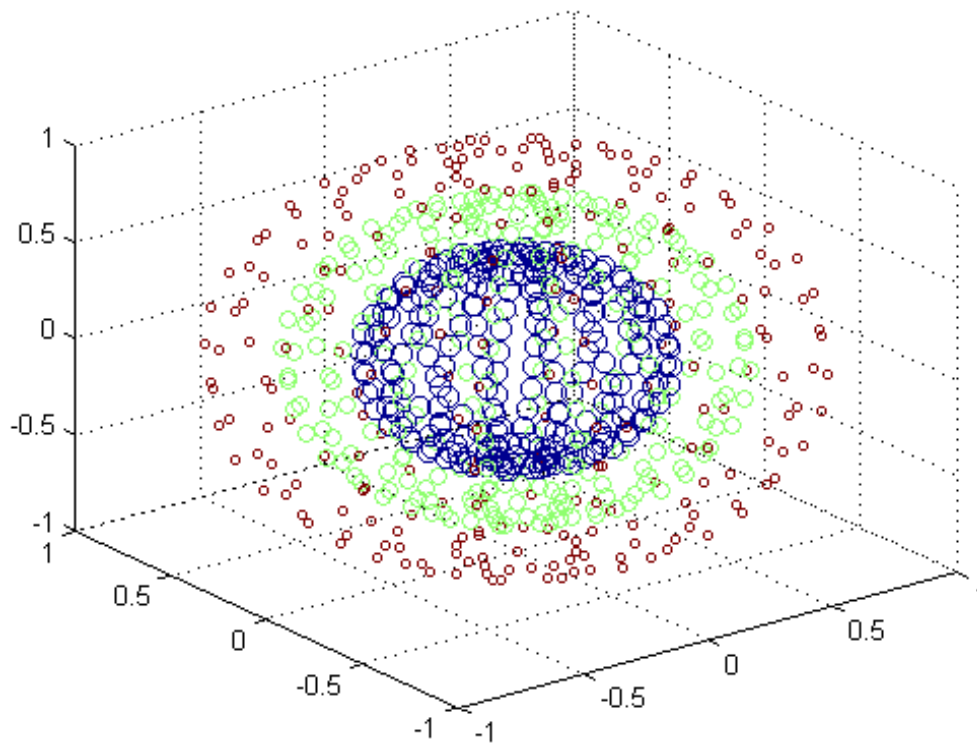

Use the handle to set the marker face color for the scatter plot.

```
set(h,'MarkerFaceColor',[0 .5 .5])
```

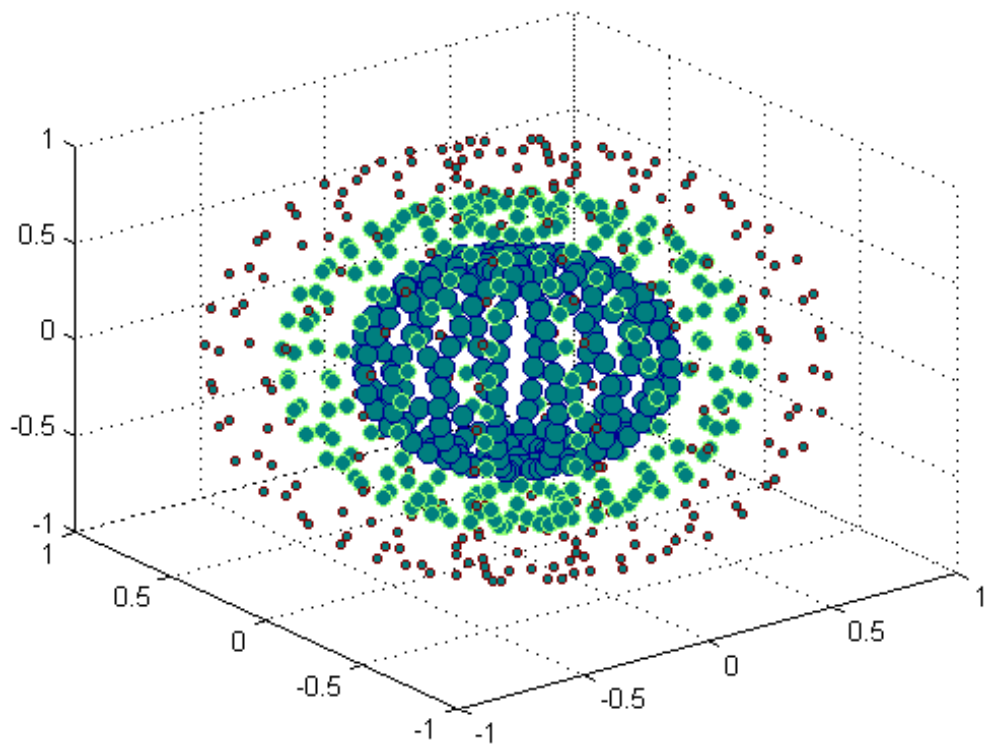
**See Also**[scatter](#) | [plot3](#) | [scattergroup](#) | [ColorSpec](#) | [LineStyle](#)

# Scattergroup Properties

---

**Purpose** Define scattergroup properties

**Modifying Properties** You can set and query graphics object properties using the `set` and `get` commands or the Property Editor (`propertyeditor`).

Note that you cannot define default property values for scattergroup objects.

See Plot Objects for information on scattergroup objects.

**Scattergroup Property Descriptions** This section provides a description of properties. Curly braces { } enclose default values.

Annotation

`hg.Annotation` object (read-only)

*Control the display of scattergroup objects in legends.* Specifies whether this scattergroup object is represented in a figure legend.

Querying the `Annotation` property returns the handle of an `hg.Annotation` object. The `hg.Annotation` object has a property called `LegendInformation`, which contains an `hg.LegendEntry` object.

Once you have obtained the `hg.LegendEntry` object, you can set its `IconDisplayStyle` property to control whether the scattergroup object is displayed in a figure legend.

<b>IconDisplayStyle Value</b>	<b>Purpose</b>
<code>on</code>	Include the scattergroup object in a legend as one entry, but not its children objects
<code>off</code>	Do not include the scattergroup or its children in a legend (default)
<code>children</code>	Include only the children of the scattergroup as separate entries in the legend



## Setting the IconDisplayStyle Property

These commands set the `IconDisplayStyle` of a graphics object with handle `hobj` to `children`, which causes each child object to have an entry in the legend:

```
hAnnotation = get(hobj, 'Annotation');
hLegendEntry = get(hAnnotation, 'LegendInformation');
set(hLegendEntry, 'IconDisplayStyle', 'children')
```

## Using the IconDisplayStyle Property

See “Control Legend Content” for more information and examples.

### BeingDeleted

`on` | `{off}` (read-only)

*This object is being deleted.* Mechanism to determine if objects are in the process of being deleted. MATLAB sets the `BeingDeleted` property to `on` when the object’s delete function callback is called (see the `DeleteFcn` property). It remains set to `on` while the delete function executes, after which the object no longer exists.

For example, an object’s delete function calls other functions that act on a number of different objects. If a function does not need to perform an action on an about-be-deleted object, it can check the object’s `BeingDeleted` property before acting.

### BusyAction

`cancel` | `{queue}`

*Callback queuing*

Determines how MATLAB handles the execution of interrupting callbacks.

A *running* callback is the currently executing callback. The *interrupting* callback is the callback that tries to interrupt the

# Scattergroup Properties

---

*running* callback. The `BusyAction` property of the *interrupting* callback determines how MATLAB handles its execution. When the `BusyAction` property is set to:

- 'queue' — Puts the *interrupting* callback in a queue to be processed after the *running* callback finishes execution.
- 'cancel' — Discards the *interrupting* callback as MATLAB finishes execution.

For information about how the `Interruptible` property of the callback controls whether other callbacks can interrupt the *running* callback, see the `Interruptible` property description.

## `ButtonDownFcn`

string | function handle

*Button press callback function.* Executes whenever you press a mouse button while the pointer is over this object, but not over another graphics object. See the `HitTestArea` property for information about selecting objects of this type.

See the figure's `SelectionType` property to determine if modifier keys were also pressed.

This property can be:

- A string that is a valid MATLAB expression
- The name of a MATLAB file
- A function handle

Set this property to a function handle that references the callback. The expressions execute in the MATLAB workspace.

For information on the syntax of callback functions, see [Function Handle Callbacks](#).

## CData

vector | m-by-3 matrix | ColorSpec

*Color of markers.* When CData is a vector the same length as XData and YData, the values in CData are linearly mapped to the colors in the current colormap. When CData is a length(XData)-by-3 matrix, it specifies the colors of the markers as RGB values.

## CDataSource

string (MATLAB variable)

*Link CData to MATLAB variable.* Set this property to a MATLAB variable that, by default, is evaluated in the base workspace to generate the CData.

MATLAB reevaluates this property only when you set it. Therefore, a change to workspace variables appearing in an expression does not change CData.

You can use the `refreshdata` function to force an update of the object's data. `refreshdata` also enables you to specify that the data source variable be evaluated in the workspace of a function from which you call `refreshdata`. See the `refreshdata` reference page for more information.

---

**Note** If you change one data source property to a variable that contains data of a different dimension, you might cause the function to generate a warning and not render the graph until you have changed all data source properties to appropriate values.

---

## Children

array of graphics object handles

# Scattergroup Properties

---

*Children of the scattergroup object.* An array containing the handle of a patch object parented to the scattergroup object (whether visible or not).

If a child object's `HandleVisibility` property is `callback` or `off`, its handle does not show up in this object's `Children` property. If you want the handle in the `Children` property, set the root `ShowHiddenHandles` property to `on`. For example:

```
set(0, 'ShowHiddenHandles', 'on')
```

## Clipping

{on} | off

*Clipping mode.* MATLAB clips graphs to the axes plot box by default. If you set `Clipping` to `off`, portions of graphs appear outside the axes plot box. This occurs if you create a plot object, set `hold` to `on`, freeze axis scaling (`axis manual`), and then create a larger plot object.

## CreateFcn

function handle | cell array containing function handle and additional arguments | string (not recommended)

*Callback function executed during object creation.* Defines a callback that executes when MATLAB creates an object. The default is an empty array.

You must specify the callback during the creation of the object. For example:

```
graphicfcn(y, 'CreateFcn', @CallbackFcn)
```

where `@CallbackFcn` is a function handle that references the callback function and `graphicfcn` is the plotting function which creates this object.

MATLAB executes this routine after setting all other object properties. Setting this property on an existing object has no effect.

The handle of the object whose `CreateFcn` is being executed is accessible only through the root `CallbackObject` property, which you can query using `gcbo`.

For information on the syntax of callback functions, see [Function Handle Callbacks](#).

## DeleteFcn

function handle | cell array containing function handle and additional arguments | string (not recommended)

*Callback executed during object deletion.* Executes when this object is deleted (for example, this might happen when you issue a `delete` command on the object, its parent axes, or the figure containing it). MATLAB executes the callback before destroying the object's properties so the callback routine can query these values. The default is an empty array.

The handle of the object whose `DeleteFcn` is being executed is accessible only through the root `CallbackObject` property, which can be queried using `gcbo`.

For information on the syntax of callback functions, see [Function Handle Callbacks](#).

See the `BeingDeleted` property for related information.

## DisplayName

string

*String used by legend.* The `legend` function uses the `DisplayName` property to label the scattergroup object in the legend. The default is an empty string.

# Scattergroup Properties

---

- If you specify string arguments with the `legend` function, MATLAB set `DisplayName` to the corresponding string and uses that string for the legend.
- If `DisplayName` is empty, `legend` creates a string of the form, `['data' n]`, where `n` is the number assigned to the object based on its location in the list of legend entries. However, `legend` does not set `DisplayName` to this string.
- If you edit the string directly in an existing legend, MATLAB set `DisplayName` to the edited string.
- If you specify a string for the `DisplayName` property and create the legend using the figure toolbar, then MATLAB uses the string defined by `DisplayName`.
- To add a legend programmatically that uses the `DisplayName` string, call `legend` with the `toggle` or `show` option.

See “Control Legend Content” for more information and examples.

## EraseMode

{normal} | none | xor | background

*Erase mode.* Controls the technique MATLAB uses to draw and erase objects. Use alternative erase modes for creating animated sequences, where control of the way individual objects are redrawn is necessary to improve performance and obtain the desired effect.

- `normal` — Redraw the affected region of the display, performing the three-dimensional analysis necessary to correctly render all objects. This mode produces the most accurate picture, but is the slowest. The other modes are faster, but do not perform a complete redraw and are therefore less accurate.
- `none` — Do not erase the object when it is moved or destroyed. While the object is still visible on the screen after erasing with `EraseMode none`, you cannot print it because MATLAB stores no information about its former location.

- `xor` — Draw and erase the object by performing an exclusive OR (XOR) with the color of the screen beneath it. This mode does not damage the color of the objects beneath it. However, the object's color depends on the color of whatever is beneath it on the display.
- `background` — Erase the object by redrawing it in the axes background Color, or the figure background Color if the axes Color property is none. This damages objects that are behind the erased object, but properly colors the erased object.

Set the axes background color with the axes Color property. Set the figure background color with the figure Color property.

## Printing with Nonnormal Erase Modes

MATLAB always prints figures as if the `EraseMode` of all objects is `normal`. This means graphics objects created with `EraseMode` set to `none`, `xor`, or `background` can look different on screen than on paper. On screen, MATLAB mathematically combines layers of colors (for example, performing an XOR on a pixel color with that of the pixel behind it) and ignore three-dimensional sorting to obtain greater rendering speed. However, these techniques are not applied to the printed output.

You can use the `getframe` command or other screen capture applications to create an image of a figure containing nonnormal mode objects.

## HandleVisibility

{on} | callback | off

*Control access to object's handle.* Determines when an object's handle is visible in its parent's list of children. `HandleVisibility` is useful for preventing command-line users from accidentally accessing objects that you need to protect for some reason.

- `on` — Handles are always visible.

# Scattergroup Properties

---

- **callback** — Handles are visible from within callback routines or functions invoked by callback routines, but not from within functions invoked from the command line. This provides a means to protect GUIs from command-line users, while allowing callback routines to have access to object handles.
- **off** — Handles are invisible at all times. Use this option when a callback invokes a function that could damage the GUI (such as evaluating a user-typed string). This option temporarily hides its own handles during the execution of that function.

## Functions Affected by Handle Visibility

When a handle is not visible in its parent's list of children, it cannot be returned by functions that obtain handles by searching the object hierarchy or querying handle properties. This includes `get`, `findobj`, `gca`, `gcf`, `gco`, `newplot`, `cla`, `clf`, and `close`.

## Properties Affected by Handle Visibility

When a handle's visibility is restricted using `callback` or `off`, the object's handle does not appear in its parent's `Children` property, figures do not appear in the root's `CurrentFigure` property, objects do not appear in the root's `CallbackObject` property or in the figure's `CurrentObject` property, and axes do not appear in their parent's `CurrentAxes` property.

## Overriding Handle Visibility

You can set the root `ShowHiddenHandles` property to `on` to make all handles visible regardless of their `HandleVisibility` settings. This does not affect the values of the `HandleVisibility` properties. See also `findall`.

## Handle Validity



Hidden handles are still valid. If you know an object's handle, you can `set` and `get` its properties and pass it to any function that operates on handles.

---

**Note** If you change one data source property to a variable that contains data of a different dimension, you might cause the function to generate a warning and not render the graph until you have changed all data source properties to appropriate values.

---

## HitTest

{on} | off

*Selectable by mouse click.* Determines whether this object can become the current object (as returned by the `gco` command and the figure `CurrentObject` property) as a result of a mouse click on the markers that compose the scatter plot. If `HitTest` is `off`, clicking this object selects the object below it (which is usually the axes containing it).

## HitTestArea

on | {off}

*Select the object by clicking markers or area of extent.* Select plot objects by:

- Clicking scatter markers (default).
- Clicking anywhere in the extent of the plot.

When `HitTestArea` is `off`, you must click the scatter markers to select the object. When `HitTestArea` is `on`, you can select this object by clicking anywhere within the extent of the plot (that is, anywhere within a rectangle that encloses all the scatter markers).

# Scattergroup Properties

---

Interruptible  
off | {on}

## *Callback routine interruption*

Controls whether MATLAB can interrupt an object's callback function when subsequent callbacks attempt to interrupt it.

For Graphics objects, the `Interruptible` property affects only the callbacks for the `ButtonDownFcn` property. A *running* callback is the currently executing callback. The *interrupting* callback is the callback that tries to interrupt the *running* callback. MATLAB handles both the callbacks based on the `Interruptible` property of the object of the *running* callback.

When the `Interruptible` property is set to:

- 'off', MATLAB finishes execution of the *running* callback without any interruptions
- 'on', these conditions apply:
  - If there is a `drawnow`, `figure`, `getframe`, `waitfor`, or `pause` command in the *running* callback, then MATLAB executes the *interrupting* callbacks which are already in the queue and returns to finish execution of the current callback.
  - If one of the above functions is not in the *running* callback, then MATLAB finishes execution of the current callback without any interruption.

`BusyAction` property of the object of interrupting callback determines whether the callback should be ignored or should be put in the queue.

Setting `Interruptible` property to on (default), allows a callback from other graphics objects to interrupt callback functions originating from this object.

---

**Note** MATLAB does not save the state of properties or the display when an interruption occurs. For example, the handle returned by the `gca` or `gcf` command may be changed as another callback is executed.

---

After the function that interrupts a callback completes, the callback resumes execution where it halted when interrupted. For more information, see “Control Callback Execution and Interruption”.

## LineWidth

size in points

*Width of linear objects and edges of filled areas.* Specify in points. 1 point =  $1/72$  inch. The default is 0.5 points.

## Marker

character (see table)

*Marker symbol.* Specifies marks that display at data points. You can set values for the `Marker` property independently from the `LineStyle` property. For a list of supported marker symbols, see the following table.

### Marker Specifiers Table

Specifier	Marker Type
'+'	Plus sign
'o'	Circle
'*'	Asterisk
'.'	Point
'x'	Cross
'square' or 's'	Square

# Scattergroup Properties

---

Specifier	Marker Type
'diamond' or 'd'	Diamond
'^'	Upward-pointing triangle
'v'	Downward-pointing triangle
'>'	Right-pointing triangle
'<'	Left-pointing triangle
'pentagram' or 'p'	Five-pointed star (pentagram)
'hexagram' or 'h' 'H'	Six-pointed star (hexagram)
'none'	No marker (default)

## MarkerEdgeColor

ColorSpec | none | auto | {flat}

*Marker edge color.* The color of the marker or the edge color for filled markers (circle, square, diamond, pentagram, hexagram, and the four triangles).

- ColorSpec — User-defined color.
- none — Specifies no color, which makes nonfilled markers invisible.
- auto — Uses same color as the axes Color property. If the axes Color property is none, then sets the color to the figure Color property.
- flat — Uses the CData property to set the color.

## MarkerFaceColor

ColorSpec | {none} | auto | flat

*Marker face color.* The fill color for markers that are closed shapes (circle, square, diamond, pentagram, hexagram, and the four triangles).

- ColorSpec — User-defined color.

- `none` — Specifies no color, which makes the interior of the marker transparent and allows the background to show through..
- `auto` — Uses same color as the axes `Color` property. If the axes `Color` property is `none`, then sets the color to the figure `Color` property.
- `flat` — Uses the `CData` property to set the color.

## Parent

handle of parent axes, `hgggroup`, or `hgtransform`

*Parent of object.* Handle of the object's parent. The parent is normally the axes, `hgggroup`, or `hgtransform` object that contains the object.

## Selected

`on` | `{off}`

*Object selection state.* When you set this property to `on`, MATLAB displays selection handles at the corners and midpoints if the `SelectionHighlight` property is also `on` (the default). You can, for example, define the `ButtonDownFcn` callback to set this property to `on`, thereby indicating that this particular object is selected. This property is also set to `on` when an object is manually selected in plot edit mode.

## SelectionHighlight

`{on}` | `off`

*Object highlighted when selected.*

- `on` — MATLAB indicates the selected state by drawing four edge handles and four corner handles.
- `off` — MATLAB does not draw the handles except when in plot edit mode and objects are selected manually.

## SizeData

square points

# Scattergroup Properties

---

*Size of markers in square points.* Area of the marker in the scatter graph in units of points. Since there are 72 points to one inch, to specify a marker that has an area of one square inch you would use a value of  $72^2$ .

**SizeDataSource**  
string (MATLAB variable)

*Link SizeData to MATLAB variable.* Set this property to a MATLAB variable that, by default, is evaluated in the base workspace to generate the **SizeData**.

MATLAB reevaluates this property only when you set it. Therefore, a change to workspace variables appearing in an expression does not change **SizeData**.

You can use the `refreshdata` function to force an update of the object's data. `refreshdata` also enables you to specify that the data source variable be evaluated in the workspace of a function from which you call `refreshdata`. See the `refreshdata` reference page for more information.

---

**Note** If you change one data source property to a variable that contains data of a different dimension, you might cause the function to generate a warning and not render the graph until you have changed all data source properties to appropriate values.

---

**Tag**  
string

*User-specified object label.* Provides a means to identify graphics objects with a user-specified label. The default is an empty string.

Use the **Tag** property and the `findobj` function to manipulate specific objects within a plotting hierarchy.

For example, create an areaseries object and set the Tag property.

```
t = area(Y, 'Tag', 'area1')
```

When you want to access objects of a given type, use `findobj` to find the object's handle. The following statement changes the `FaceColor` property of the object whose `Tag` is `area1`.

```
set(findobj('Tag', 'area1'), 'FaceColor', 'red')
```

## Type

string (read-only)

*Type of graphics object.* String that identifies the class of the graphics object. Use this property to find all objects of a given type within a plotting hierarchy. For `stemseries` objects, `Type` is `'hggroup'`. The following statement finds all the `hggroup` objects in the current axes.

```
t = findobj(gca, 'Type', 'hggroup');
```

## UIContextMenu

handle of `uicontextmenu` object

*Associate context menu with object.* Handle of a `uicontextmenu` object created in the object's parent figure. Use the `uicontextmenu` function to create the context menu. MATLAB displays the context menu whenever you right-click over the object. The default value is an empty array.

## UserData

array

*User-specified data.* Data you want to associate with this object (including cell arrays and structures). The default value is an empty array. MATLAB does not use this data, but you can access it using the `set` and `get` commands.

# Scattergroup Properties

---

## Visible

{on} | off

*Visibility of object and its children.*

- on — Object and all children of the object are visible unless the child object's `Visible` property is `off`.
- off — Object not displayed. However, the object still exists and you can set and query its properties.

## XData

array

*X-coordinates of scatter markers.* The `scatter` function draws individual markers at each *x*-axis location in the `XData` array. The input argument `X` in the `scatter` function calling syntax assigns values to `XData`.

## XDataSource

MATLAB variable, as a string

*Link XData to MATLAB variable.* Set this property to a MATLAB variable that is evaluated in the base workspace to generate the `XData`. The default value is an empty array.

```
set(h, 'XDataSource', 'xdatavariablename')
```

MATLAB requires a call to `refreshdata` when you set this property. Changing workspace variables used as an object's `XDataSource` does not change the object's `XData` values, but you can use `refreshdata` to force an update of the object's data. `refreshdata` also lets you specify that the data source variable be evaluated in the workspace of a function from which you call `refreshdata`.



---

**Note** If you change one data source property to a variable that contains data of a different dimension, you might cause the function to generate a warning and not render the graph until you have changed all data source properties to appropriate values.

---

## YData

scalar | vector | matrix

*Y-coordinates of scatter markers.* The `scatter` function draws individual markers at each *y*-axis location in the YData array.

The input argument *Y* in the `scatter` function calling syntax assigns values to YData.

## YDataSource

MATLAB variable, as a string

*Link YData to MATLAB variable.* Set this property to a MATLAB variable that is evaluated in the base workspace to generate the YData. The default value is an empty array.

```
set(h, 'YDataSource', 'Ydatavariablename')
```

MATLAB requires a call to `refreshdata` when you set this property. Changing workspace variables used as an object's YDataSource does not change the object's YData values, but you can use `refreshdata` to force an update of the object's data. `refreshdata` also lets you specify that the data source variable be evaluated in the workspace of a function from which you call `refreshdata`.

# Scattergroup Properties

---

---

**Note** If you change one data source property to a variable that contains data of a different dimension, you might cause the function to generate a warning and not render the graph until you have changed all data source properties to appropriate values.

---

## ZData

vector

*Z-coordinates.* A vector defining the *z*-coordinates for the graph. XData and YData must be the same length and have the same number of rows.

## ZDataSource

MATLAB variable, as a string

*Link ZData to MATLAB variable.* Set this property to a MATLAB variable that is evaluated in the base workspace to generate the ZData. The default value is an empty array.

```
set(h, 'ZDataSource', 'zdatavariablename')
```

MATLAB requires a call to `refreshdata` when you set this property. Changing workspace variables used as an object's ZDataSource does not change the object's ZData values, but you can use `refreshdata` to force an update of the object's data. `refreshdata` also lets you specify that the data source variable be evaluated in the workspace of a function from which you call `refreshdata`.

---

**Note** If you change one data source property to a variable that contains data of a different dimension, you might cause the function to generate a warning and not render the graph until you have changed all data source properties to appropriate values.

---

**Purpose**

Schur decomposition

**Syntax**

```
T = schur(A)
T = schur(A, flag)
[U, T] = schur(A, ...)
```

**Description**

The `schur` command computes the Schur form of a matrix.

`T = schur(A)` returns the Schur matrix `T`.

`T = schur(A, flag)` for real matrix `A`, returns a Schur matrix `T` in one of two forms depending on the value of `flag`:

'complex'	<code>T</code> is triangular and is complex if <code>A</code> is real and has complex eigenvalues.
'real'	<code>T</code> has the real eigenvalues on the diagonal and the complex eigenvalues in 2-by-2 blocks on the diagonal. 'real' is the default when <code>A</code> is real.

If `A` is complex, `schur` returns the complex Schur form in matrix `T` and `flag` is ignored. The complex Schur form is upper triangular with the eigenvalues of `A` on the diagonal.

The function `rsf2csf` converts the real Schur form to the complex Schur form.

`[U, T] = schur(A, ...)` also returns a unitary matrix `U` so that  $A = U^*T^*U'$  and  $U' * U = \text{eye}(\text{size}(A))$ .

**Examples**

`H` is a 3-by-3 eigenvalue test matrix:

```
H = [-149 -50 -154
 537 180 546
 -27 -9 -25]
```

Its Schur form is

```
schur(H)
```

```
ans =
 1.0000 -7.1119 -815.8706
 0 2.0000 -55.0236
 0 0 3.0000
```

The eigenvalues, which in this case are 1, 2, and 3, are on the diagonal. The fact that the off-diagonal elements are so large indicates that this matrix has poorly conditioned eigenvalues; small changes in the matrix elements produce relatively large changes in its eigenvalues.

## See Also

[eig](#) | [hess](#) | [qz](#) | [rsf2csf](#)

**Purpose** Sequence of MATLAB statements in file

**Description** A script file is an external file that contains a sequence of MATLAB statements. By typing the filename, you can obtain subsequent MATLAB input from the file. Script files have a filename extension of `.m`.

Scripts are the simplest kind of MATLAB program. They are useful for automating blocks of MATLAB commands, such as computations you have to perform repeatedly from the command line. Scripts can operate on existing data in the workspace, or they can create new data on which to operate. Although scripts do not return output arguments, any variables that they create remain in the workspace, so you can use them in further computations. In addition, scripts can produce graphical output using commands like `plot`.

Scripts can contain any series of MATLAB statements. They require no declarations or begin/end delimiters.

Like any MATLAB program, scripts can contain comments. Any text following a percent sign (`%`) on a given line is comment text. Comments can appear on lines by themselves, or you can append them to the end of any executable line.

**See Also** `echo` | `function` | `type`

# scatteredInterpolant

---

**Purpose** Scattered data interpolation

**Description** Use `scatteredInterpolant` to perform interpolation on a 2-D or 3-D “Scattered Data” on page 1-6207 set. For example, you can pass a set of  $(x, y)$  points and values,  $v$ , to `scatteredInterpolant`, and it returns a surface of the form  $v = F(x, y)$ . This surface always passes through the sample values at the point locations. You can evaluate this surface at any query point,  $(xq, yq)$ , to produce an interpolated value,  $vq$ .

Use `scatteredInterpolant` to create the “Interpolant” on page 1-6207,  $F$ . Then, you can evaluate  $F$  at specific points using any of the following syntaxes:

- $Vq = F(Pq)$  specifies the query points in the matrix  $Pq$ . Each row in  $Pq$  contains the coordinates of a query point.
- $Vq = F(Xq, Yq)$  and  $Vq = F(Xq, Yq, Zq)$  specify the query points as two or three matrices of equal size.
- $Vq = F(\{xq, yq\})$  and  $Vq = F(\{xq, yq, zq\})$  specify the query points as “Grid Vectors” on page 1-6207. The interpolated values are returned in  $Vq$ . Use this syntax to conserve memory when you want to query a large grid of points.

**Construction**  $F = \text{scatteredInterpolant}(x, y, v)$  creates an interpolant that fits a surface of the form  $v = F(x, y)$ . Vectors  $x$  and  $y$  specify the  $(x, y)$  coordinates of the sample points.  $v$  is a vector that contains the sample values associated with the points,  $(x, y)$ .

$F = \text{scatteredInterpolant}(x, y, z, v)$  creates a 3-D interpolant of the form  $v = F(x, y, z)$ .

$F = \text{scatteredInterpolant}(P, v)$  specifies the coordinates of the sample points as an array. The rows of  $P$  contain the  $(x, y)$  or  $(x, y, z)$  coordinates for the values in  $v$ .

$F = \text{scatteredInterpolant}(\_, \text{Method})$  specifies a string that describes an interpolation method: 'nearest', 'linear', or 'natural'. Specify `Method` as the last input argument in any of the first three syntaxes.

`F = scatteredInterpolant( ___, Method, ExtrapolationMethod)` specifies both the interpolation and extrapolation methods as strings. `Method` can be one of three strings: 'nearest', 'linear', or 'natural'. Specify `ExtrapolationMethod` as one of the following strings: 'nearest', 'linear', or 'none'. Pass `Method` and `ExtrapolationMethod` together as the last two input arguments in any of the first three syntaxes.

`F = scatteredInterpolant()` creates an empty scattered data interpolant. Use `F.Points = P` to initialize `F` with the points in matrix `P`. Use `F.Values = v` to initialize `F` with the values in `v`.

## Input Arguments

### **x**

Sample points *x*-coordinates, specified as a vector of the same size as `v`.

### **y**

Sample points *y*-coordinates, specified as a vector of the same size as `v`.

### **z**

Sample points *z*-coordinates, specified as a vector of the same size as `v`.

### **P**

Sample points array, specified as an *m*-by-*n* matrix, where *m* is the number of points and *n* is the dimension of the space where the points reside. Each row of `P` contains the (*x*, *y*) or (*x*, *y*, *z*) coordinates of a sample point.

### **v**

Sample values vector, specified as a vector of that defines the values at the sample points.

## Method

# scatteredInterpolant

---

Interpolation method, specified as one of these strings.

Method String	Description
'linear' (default)	Linear interpolation.
'nearest'	Nearest neighbor interpolation.
'natural'	Natural neighbor interpolation.

## ExtrapolationMethod

Extrapolation method, specified as one of these strings.

ExtrapolationMethod String	Description
'linear'	Linear extrapolation based on boundary gradients. Default when Method is
'nearest'	Nearest neighbor extrapolation. This method evaluates to the value of the nearest neighbor on the boundary. Default when Method = 'nearest'.
'none'	No extrapolation. Any queries outside the convex hull of F.Points return NaN.

## Properties

### Points

Array of sample points (locations) for the values in F.Values. Each row of F.Points contains the (x, y) or (x, y, z) coordinates of a sample point.

### Values

Vector of values associated with each point in F.Points.

### Method

A string specifying the method used to interpolate the data: 'nearest', 'linear', or 'natural'.



## ExtrapolationMethod

A string specifying the method used to extrapolate the data: 'nearest', 'linear', or 'none'. A value of 'none' indicates that extrapolation is disabled.

## Definitions

### Interpolant

Interpolating function that you can evaluate at query locations.

### Scattered Data

A set of points that have no structure among their relative locations.

### Full Grid

A grid represented as a set of arrays. For example, you can create a full grid using `ndgrid`.

### Grid Vectors

A set of vectors that serve as a compact representation of a grid in `ndgrid` format. For example, `[X,Y] = ndgrid(xg,yg)` returns a full grid in the matrices X and Y. You can represent the same grid using the grid vectors, `xg` and `yg`.

## Copy Semantics

Value. To learn how value classes affect copy operations, see [Copying Objects](#) in the MATLAB documentation.

## Indexing

`scatteredInterpolant` supports index-based editing of the properties of `F`. You can add or remove points in `F.Points` and update the corresponding values in `F.Values`. For example, `F.Points(5,:) = []` removes the fifth point, and `F.Values(5) = []` removes the corresponding value.

## Examples

### 2-D Interpolation

Define 200 random points.

```
xy = -2.5 + 5*gallery('uniformdata',[200 2],0);
x = xy(:,1);
```

# scatteredInterpolant

---

```
y = xy(:,2);
```

Sample an exponential function. These are the sample values for the interpolant.

```
v = x.*exp(-x.^2-y.^2);
```

Create the interpolant.

```
F = scatteredInterpolant(x,y,v);
```

Evaluate the interpolant at query locations ( $xq$ ,  $yq$ ).

```
ti = -2:.25:2;
[xq,yq] = meshgrid(ti,ti);
vq = F(xq,yq);
```

Plot the result.

```
figure
mesh(xq,yq,vq);
hold on;
plot3(x,y,v,'o');
hold off;
```

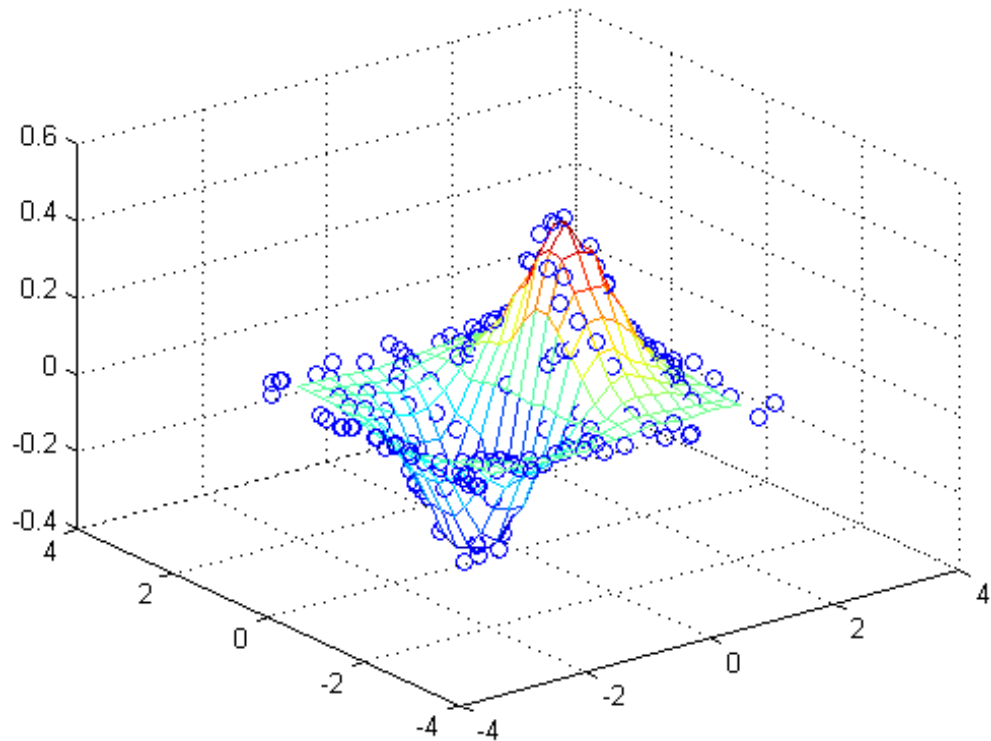

## 2-D Extrapolation

Query the interpolant at a single point outside the convex hull using nearest neighbor extrapolation.

Define a matrix of 200 random points.

```
P = -2.5 + 5*gallery('uniformdata',[200 2],0);
```

# scatteredInterpolant

---

Sample an exponential function. These are the sample values for the interpolant.

```
x = P(:,1);
y = P(:,2);
v = x.*exp(-x.^2-y.^2);
```

Create the interpolant, specifying linear interpolation and nearest neighbor extrapolation.

```
F = scatteredInterpolant(P,v,'linear','nearest')
```

```
F =
```

```
scatteredInterpolant with properties:
```

```
Points: [200x2 double]
```

```
Values: [200x1 double]
```

```
Method: 'linear'
```

```
ExtrapolationMethod: 'nearest'
```

Evaluate the interpolant outside the convex hull.

```
vq = F(3.0,-1.5)
```

```
vq =
```

```
0.0031
```

Disable extrapolation and evaluate F at the same point.

```
F.ExtrapolationMethod = 'none';
```

```
vq = F(3.0,-1.5)
```

```
vq =

 NaN
```

## Replacement of Sample Values

Replace the elements in the `Values` property when you want to change the values at the sample points. You get immediate results when you evaluate the new interpolant because the original triangulation has not changed.

Create 50 random points.

```
x = -2.5 + 5*gallery('uniformdata',[50 1],0);
y = -2.5 + 5*gallery('uniformdata',[50 1],1);
```

Sample an exponential function. These are the sample values for the interpolant.

```
v = x.*exp(-x.^2-y.^2);
```

Create the interpolant.

```
F = scatteredInterpolant(x,y,v)
```

```
F =
```

```
scatteredInterpolant with properties:
```

```
 Points: [50x2 double]
 Values: [50x1 double]
 Method: 'linear'
 ExtrapolationMethod: 'linear'
```

# scatteredInterpolant

---

Evaluate the interpolant at (1.40,1.90).

```
F(1.40,1.90)
```

```
ans =
```

```
0.0029
```

Change the interpolant sample values.

```
vnew = x.^2 + y.^2;
```

```
F.Values = vnew;
```

Evaluate the interpolant at (1.40,1.90).

```
F(1.40,1.90)
```

```
ans =
```

```
6.1109
```

## See Also

[griddedInterpolant](#) | [interp1](#) | [interp2](#) | [interp3](#) | [meshgrid](#) | [ndgrid](#)

## How To

- Class Attributes
- Property Attributes
- “Interpolating Gridded Data”

<b>Purpose</b>	Secant of angle in radians
<b>Syntax</b>	$Y = \sec(X)$
<b>Description</b>	$Y = \sec(X)$ returns the secant of the elements of $X$ . The <code>sec</code> function operates element-wise on arrays. The function accepts both real and complex inputs. For real values of $X$ in the interval $[-\text{Inf}, \text{Inf}]$ , <code>sec</code> returns real values in the interval $[-\text{Inf}, -1]$ and $[1, \text{Inf}]$ . For complex values of $X$ , <code>sec</code> returns complex values. All angles are in radians.
<b>Input Arguments</b>	<b>X - Input angle in radians</b> scalar value   vector   matrix   N-D array  Input angle in radians, specified as a real-valued or complex-valued scalar value, vector, matrix or N-D array. The <code>sec</code> operation is element-wise when $X$ is non-scalar.  <b>Data Types</b> single   double <b>Complex Number Support:</b> Yes
<b>Output Arguments</b>	<b>Y - Secant of input angle</b> scalar value   vector   matrix   N-D array  Secant of input angle, returned as real-valued or complex-valued scalar value, vector, matrix or N-D array.
<b>Examples</b>	<b>Plot Secant Function</b>  Plot the secant over the domain $-\pi/2 < x < \pi/2$ and $\pi/2 < x < 3\pi/2$ .  <pre>x1 = -pi/2+0.01:0.01:pi/2-0.01; x2 = pi/2+0.01:0.01:(3*pi/2)-0.01; plot(x1,sec(x1),x2,sec(x2)), grid on</pre>

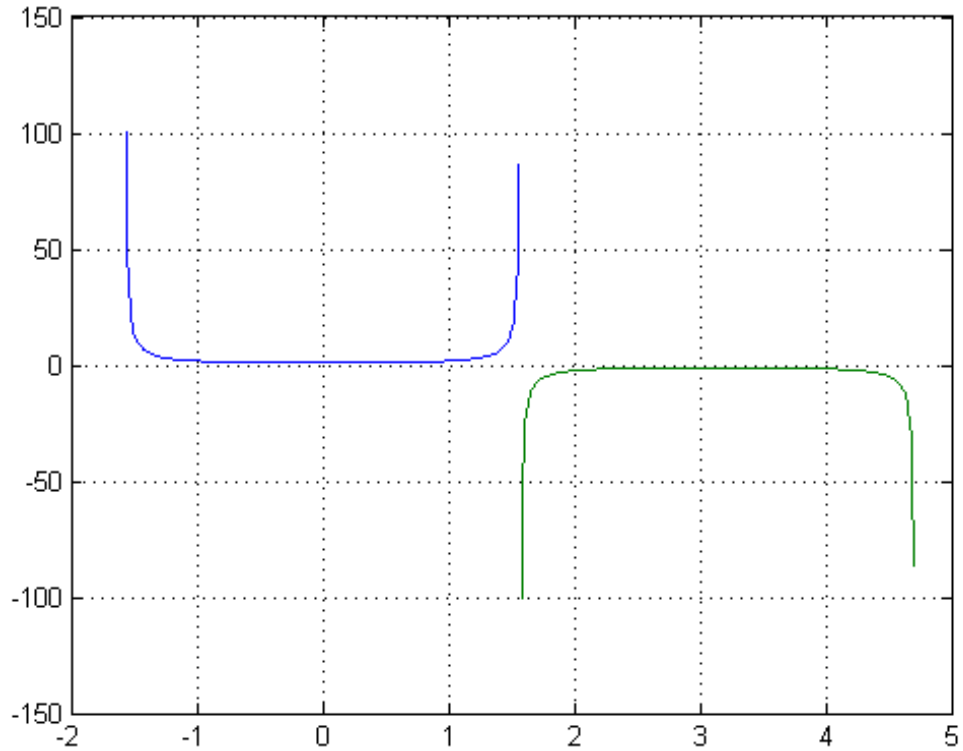

### **Secant of Vector of Complex Angles**

Calculate the secant of the complex angles in vector x.

```
x = [-i pi+i*pi/2 -1+i*4];
y = sec(x)
```

y =



$$0.6481 + 0.0000i \quad -0.3985 + 0.0000i \quad 0.0198 - 0.0308i$$

## Definitions

### Secant Function

The secant of an angle,  $\alpha$ , defined with reference to a right angled triangle is

$$\secant(\alpha) = \frac{1}{\cosine(\alpha)} = \frac{\text{hypotenuse}}{\text{adjacent side}} = \frac{h}{b}.$$

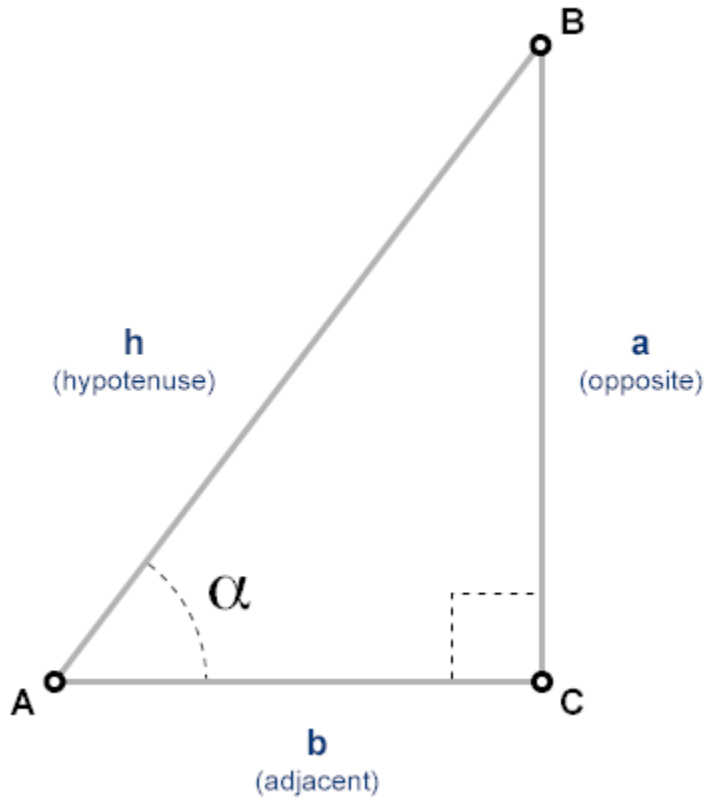

The secant of a complex angle,  $\alpha$ , is

$$\secant(\alpha) = \frac{2}{e^{i\alpha} + e^{-i\alpha}}.$$

**See Also**

secd | sech | asec | asecd | asech

<b>Purpose</b>	Secant of argument in degrees
<b>Syntax</b>	$Y = \text{secd}(X)$
<b>Description</b>	$Y = \text{secd}(X)$ returns the secant of the elements of $X$ , which are expressed in degrees.
<b>Input Arguments</b>	<p><b>X - Angle in degrees</b> scalar value   vector   matrix   N-D array</p> <p>Angle in degrees, specified as a real-valued or complex-valued scalar, vector, matrix, or N-D array. The <code>secd</code> operation is element-wise when <math>X</math> is nonscalar.</p> <p><b>Example:</b></p> <p><b>Data Types</b> single   double</p> <p><b>Complex Number Support:</b> Yes</p>
<b>Output Arguments</b>	<p><b>Y - Secant of angle</b> scalar value   vector   matrix   N-D array</p> <p>Secant of angle, returned as a real-valued or complex-valued scalar, vector, matrix, or N-D array of the same size as <math>X</math>.</p>
<b>Examples</b>	<p><b>Secant of 90 degrees compared to secant of <math>\pi/2</math> radians</b></p> <pre>secd(90)  ans =       Inf  sec(pi/2)  ans =   1.6331e+16</pre>

# secd

---

$\text{secd}(90)$  is infinite, whereas  $\text{sec}(\pi/2)$  is large but finite.

## **Secant of vector of complex angles, specified in degrees**

```
z = [35+i 15+2i 10+3i];
y = secd(z)
```

```
y =
```

```
1.2204 + 0.0149i 1.0346 + 0.0097i 1.0140 + 0.0094i
```

## **See Also**

[sec](#) | [asec](#) | [asecd](#)

**Purpose** Hyperbolic secant

**Syntax**  $Y = \operatorname{sech}(X)$

**Description** The sech function operates element-wise on arrays. The function's domains and ranges include complex values. All angles are in radians.  $Y = \operatorname{sech}(X)$  returns an array the same size as  $X$  containing the hyperbolic secant of the elements of  $X$ .

**Examples** **Graph of Hyperbolic Secant Function**

Graph the hyperbolic secant over the domain  $-2\pi \leq x \leq 2\pi$ .

```
x = -2*pi:0.01:2*pi;
plot(x,sech(x)), grid on
```

# sech

---

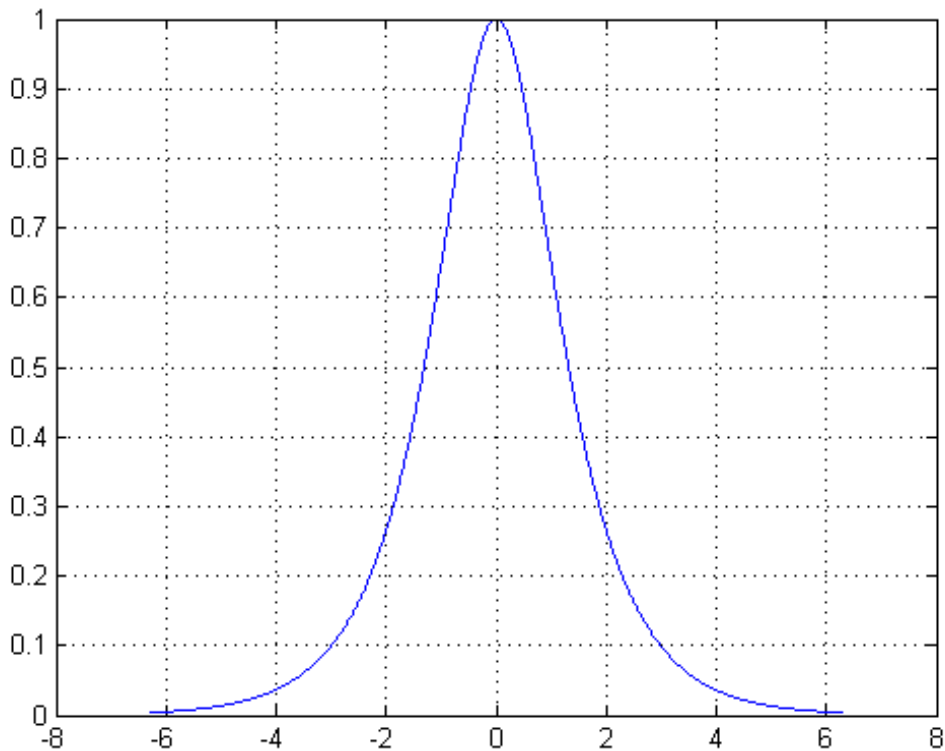

## Definitions **Hyperbolic Secant**

The hyperbolic secant of  $z$  is

$$\text{sech}(z) = \frac{1}{\cosh(z)}.$$

**See Also**    [asech](#) | [sec](#) | [sinh](#) | [cosh](#)

**Purpose** Select, move, resize, or copy axes and uicontrol graphics objects

**Syntax** `A = selectmoveresize`  
`set(gca, 'ButtonDownFcn', 'selectmoveresize')`

**Description** `selectmoveresize` is useful as the callback routine for axes and uicontrol button down functions. When executed, it selects the object and allows you to move, resize, and copy it.

`A = selectmoveresize` returns a structure array containing

- `A.Type`: a string containing the action type, which can be `Select`, `Move`, `Resize`, or `Copy`
- `A.Handles`: a list of the selected handles, or, for a `Copy`, an `m-by-2` matrix containing the original handles in the first column and the new handles in the second column

`set(gca, 'ButtonDownFcn', 'selectmoveresize')` sets the `ButtonDownFcn` property of the current axes to `selectmoveresize`:

**See Also** `axes` | `uicontrol`

# matlab.unittest.selectors

---

**Purpose** Summary of classes in MATLAB Selectors Interface

**Description** Use selectors to filter or select elements of a test suite based on their attributes. The matlab.unittest.selectors package consists of the following selectors.

matlab.unittest.selectors.HasBaseFolder Selector for TestSuite elements determined by folder

matlab.unittest.selectors.HasName Selector for TestSuite elements determined by name

matlab.unittest.selectors.HasParameters Selector for TestSuite elements determined by parameterization

matlab.unittest.selectors.HasSharedTestFixture Selector for TestSuite elements that use shared test fixture

**See Also** matlab.unittest.TestSuite.selectIf



- Purpose** Selector for TestSuite elements determined by parameterization
- Description** The HasParameter selector filters TestSuite array elements determined by parameterization.
- Construction** matlab.unittest.selectors.HasParameter constructs a selector for TestSuite elements determined by their parameterization. When you instantiate HasParameter without input arguments, the resulting TestSuite array only contains elements that have parameterized test methods.

matlab.unittest.selectors.HasParameter(Name, Value) constructs a selector with additional options specified by one or more Name, Value pair arguments. The selector filters based on the name of the property that defines a parameter, the name of the parameter, and the value of the parameter. For an element to be selected for the TestSuite array, it must have at least one parameter that satisfies all the conditions.

## Input Arguments

### Name-Value Pair Arguments

Specify optional comma-separated pairs of Name, Value arguments. Name is the argument name and Value is the corresponding value. Name must appear inside single quotes ( ' '). You can specify several name and value pair arguments in any order as Name1, Value1, ..., NameN, ValueN.

### Property

Name of the property that defines the parameter specified as a string or as an instance of the matlab.unittest.constraints.Constraint class. If the specified property name is a string, the testing framework creates an IsEqualTo constraint with the input string, Property, as the expected value.

### Name

Name of the parameter specified as a string or as an instance of the matlab.unittest.constraints.Constraint class. If the specified

# matlab.unittest.selectors.HasParameter

---

name is a string, the testing framework creates an `IsEqualTo` constraint with the input string, `Name`, as the expected value.

## Value

Value of the parameter specified as any MATLAB data type or as an instance of the `matlab.unittest.constraints.Constraint` class. If the specified property name is not a constraint, the testing framework creates an `IsEqualTo` constraint with the input data, `Value`, as the expected value.

## Properties

### PropertyConstraint

Condition that the test element's parameter property name must satisfy to be included in the test suite, specified as an instance of the `Constraint` in the `Property` input argument.

### NameConstraint

Condition that the test element's parameter name must satisfy to be included in the test suite, specified as an instance of the `Constraint` in the `Name` input argument.

### ValueConstraint

Condition that the test element's parameter property value must satisfy to be included in the test suite, specified as an instance of the `Constraint` in the `Value` input argument.

## Copy Semantics

Value. To learn how value classes affect copy operations, see [Copying Objects](#) in the MATLAB documentation.

## Examples

### Filter Test Suite by Parameterization

In your working folder, create `testZeros.m`. This class contains four test methods.

```
classdef testZeros < matlab.unittest.TestCase
 properties (TestParameter)
 type = {'single', 'double', 'uint16'};
```

# matlab.unittest.selectors.HasParameter

---

```
 outSize = struct('s2d',3, 's3d',[2 5 4]);
 end

 methods (Test)
 function testClass(testCase, type, outSize)
 testCase.verifyClass(zeros(outSize,type), type);
 end

 function testSize(testCase, outSize)
 testCase.verifySize(zeros(outSize), outSize);
 end

 function testDefaultClass(testCase)
 testCase.verifyClass(zeros, 'double');
 end

 function testDefaultSize(testCase)
 testCase.verifySize(zeros, [1 1]);
 end

 function testDefaultValue(testCase)
 testCase.verifyEqual(zeros,0);
 end
 end
end
```

The test class contains two parameterized test methods, `testClass` and `testSize`.

At the command prompt, create a test suite from the file.

```
s = matlab.unittest.TestSuite.fromFile('testZeros.m');
{s.Name}'
```

```
ans =
```

```
'testZeros/testClass(type=single,outSize=s2d)'
'testZeros/testClass(type=single,outSize=s3d)'
'testZeros/testClass(type=double,outSize=s2d)'
```

# matlab.unittest.selectors.HasParameter

---

```
'testZeros/testClass(type=double,outSize=s3d) '
'testZeros/testClass(type=uint16,outSize=s2d) '
'testZeros/testClass(type=uint16,outSize=s3d) '
'testZeros/testSize(outSize=s2d) '
'testZeros/testSize(outSize=s3d) '
'testZeros/testDefaultClass '
'testZeros/testDefaultSize '
'testZeros/testDefaultValue '
```

The suite contains 11 test elements: 6 from the parameterized `testClass` method, 2 from the parameterized `testSize` method, and 1 from each of the `testDefaultClass`, `testDefaultSize`, and `testDefaultValue` methods.

Select all of the test elements from parameterized test methods.

```
import matlab.unittest.selectors.HasParameter;
```

```
s1 = s.selectIf(HasParameter);
{s1.Name}'
```

```
ans =
```

```
'testZeros/testClass(type=single,outSize=s2d) '
'testZeros/testClass(type=single,outSize=s3d) '
'testZeros/testClass(type=double,outSize=s2d) '
'testZeros/testClass(type=double,outSize=s3d) '
'testZeros/testClass(type=uint16,outSize=s2d) '
'testZeros/testClass(type=uint16,outSize=s3d) '
'testZeros/testSize(outSize=s2d) '
'testZeros/testSize(outSize=s3d) '
```

The suite contains the eight test elements from the two parameterized test methods.

Select all of the test elements from nonparameterized test methods.

```
s2 = s.selectIf(~HasParameter);
```

```
{s2.Name}'

ans =

 'testZeros/testDefaultClass'
 'testZeros/testDefaultSize'
 'testZeros/testDefaultValue'
```

Select all test elements that are parameterized and have a property named 'type' with a parameter name 'double'.

```
s3 = s.selectIf(HasParameter('Property','type','Name','double'));
{s3.Name}'

ans =

 'testZeros/testClass(type=double,outSize=s2d)'
 'testZeros/testClass(type=double,outSize=s3d)'
```

The resulting suite contains two elements. The `testClass` method is the only method in `testZeros` that uses the 'type' property. Selecting only 'double' from the parameters results in two test elements — one for each value of 'outSize'.

Select all test elements that have a parameter defined by a property starting with 't'.

```
import matlab.unittest.constraints.StartsWithSubstring;

s4 = s.selectIf(HasParameter('Property',StartsWithSubstring('t')));
{s4.Name}'

ans =

 'testZeros/testClass(type=single,outSize=s2d)'
 'testZeros/testClass(type=single,outSize=s3d)'
 'testZeros/testClass(type=double,outSize=s2d)'
 'testZeros/testClass(type=double,outSize=s3d)'
```

# matlab.unittest.selectors.HasParameter

---

```
'testZeros/testClass(type=uint16,outSize=s2d)'
'testZeros/testClass(type=uint16,outSize=s3d)'
```

The resulting suite contains the six parameterized test elements from the `testClass` method. The `testSize` method is parameterized, but the elements from the method are not included in the suite because the method does not use a property that starts with 't'.

Select all test elements that are parameterized and test the zeros function with a 2-D array. A parameter value representing a 2-D array has a length of 1 (for example `zeros(3)`) or 2 (for example `zeros(2,3)`).

```
import matlab.unittest.constraints.HasLength;

s5 = s.selectIf(HasParameter('Property','outSize',...
 'Value', HasLength(1)|HasLength(2)));
{s5.Name}'
```

```
ans =

 'testZeros/testClass(type=single,outSize=s2d)'
 'testZeros/testClass(type=double,outSize=s2d)'
 'testZeros/testClass(type=uint16,outSize=s2d)'
 'testZeros/testSize(outSize=s2d)'
```

Select only the test element that tests that the output is a double data type and that it has the correct size for a 2-D array.

```
s6 = s.selectIf(HasParameter('Property','type','Name','double')...
 & HasParameter('Property','outSize','Name','s2d'))
```

```
s6 =
```

Test with properties:

```
 Name: 'testZeros/testClass(type=double,outSize=s2d)'
Parameterization: [1x2 matlab.unittest.parameters.TestParameter]
SharedTestFixtures: []
```

## See Also

[selectIf](#) | [fromClass](#) | [fromFile](#) | [fromFolder](#) |  
[fromMethod](#) | [fromPackage](#) | [matlab.unittest.selectors](#)  
| [matlab.unittest.parameters](#)

## Related Examples

- “Create Basic Parameterized Test”
- “Create Advanced Parameterized Test”

## Concepts

# matlab.unittest.selectors.HasSharedTestFixture

---

**Purpose** Selector for TestSuite elements that use shared test fixture

**Description** The HasSharedTestFixture selector filters TestSuite array elements based on shared test fixtures.

**Construction** `matlab.unittest.selectors.HasSharedTestFixture(f)` constructs a selector for TestSuite elements based on their required shared test fixtures. For an element to be selected for the TestSuite array, it must use a fixture that is compatible with the specified fixture, `f`.

## Input Arguments

### **f** - Shared test fixture

Fixture

Shared test fixture specified as a `matlab.unittest.fixtures.Fixture` instance. The TestSuite array element must use the shared test fixture, `f`, to be selected for the TestSuite.

**Properties** **ExpectedFixture**

The shared test fixture that a TestSuite array element must use to be selected for the TestSuite. The `ExpectedFixture` property is specified as a `matlab.unittest.fixtures.Fixture` in the input argument, `f`.

**Copy Semantics** Value. To learn how value classes affect copy operations, see Copying Objects in the MATLAB documentation.

**Examples** **Filter Test Suite by Shared Test Fixtures**

Create a package folder, `+mytestpackage`, in your current working folder. This package contains two test classes.

In the `+mytestpackage` folder, create `AExampleTest.m`. This class contains two tests that use a suppressed warnings fixture.

```
classdef (SharedTestFixtures={matlab.unittest.fixtures.SuppresseWarnings
```



# matlab.unittest.selectors.HasSharedTestFixture

---

```
 'MATLAB:rmpath:DirNotFound'}})...
 AExampleTest < matlab.unittest.TestCase
 methods (Test)
 function testOne(testCase)
 % test code
 end
 function testTwo(testCase)
 % test code
 end
 end
end
```

In the `+mytestpackage` folder, create `BExampleTest.m`. This class contains one test that uses a shared path fixture and a suppressed warnings fixture.

```
classdef (SharedTestFixtures={...
 matlab.unittest.fixtures.PathFixture(...
 fullfile(matlabroot,'help','techdoc','matlab_oo','examples')
 matlab.unittest.fixtures.SuppressedWarningsFixture(...
 'MATLAB:rmpath:DirNotFound'}}) ...
 BExampleTest < matlab.unittest.TestCase
 methods(Test)
 function testPathAdd(testCase)
 % test code
 end
 end
end
```

At the command prompt, define the following fixtures.

```
pf = matlab.unittest.fixtures.PathFixture(...
 fullfile(matlabroot,'help','techdoc','matlab_oo','examples'));
swf = matlab.unittest.fixtures.SuppressedWarningsFixture(...
 'MATLAB:rmpath:DirNotFound');
```

Create a test suite from the package.

# matlab.unittest.selectors.HasSharedTestFixture

---

```
import matlab.unittest.TestSuite;
import matlab.unittest.selectors.HasSharedTestFixture;
```

```
suite = TestSuite.fromPackage('mytestpackage')
```

```
suite =
```

```
1x3 Test array with properties:
```

```
 Name
Parameterization
SharedTestFixtures
```

The test suite has three test elements.

Create a filtered suite that only contains tests that use the path fixture, `pf`.

```
s1 = suite.selectIf(HasSharedTestFixture(pf));
```

The resulting suite, `s1`, contains the test element from `BExampleTest.m`, since the test in that class uses the shared test fixture, `pf`.

Alternatively, pass the selector to the `TestSuite.fromPackage` method instead of generating a full test suite, and then using the `TestSuite.selectIf` method to filter the suite.

```
s1 = TestSuite.fromPackage('mytestpackage', HasSharedTestFixture(pf));
```

Create a filtered test suite that contains tests that use the suppressed warnings fixture, `swf`, but not the path fixture, `pf`.

```
s2 = suite.selectIf(~HasSharedTestFixture(pf) & HasSharedTestFixture(swf))
```

The test suite, `s2`, only contains the two test elements from `AExampleTest.m`. Tests in `BExampleTest.m` are excluded because, in addition to the suppressed warnings fixture, they use the path fixture.

# matlab.unittest.selectors.HasSharedTestFixture

---

Create a filtered suite that only contains tests that use the path fixture to a different location.

```
pf2 = matlab.unittest.fixtures.PathFixture(fullfile(matlabroot));
s3 = TestSuite.fromPackage('mytestpackage', HasSharedTestFixture(pf2,

s3 =
```

1x0 Test array with properties:

```
Name
Parameterization
SharedTestFixtures
```

The test suite does not contain any test elements. The tests in `BExampleTest.m` use a shared path fixture, but the selected path fixture, `pf2`, adds a different folder to the path so its tests are not included in the suite.

## See Also

[selectIf](#) | [fromClass](#) | [fromFile](#) | [fromFolder](#) | [fromMethod](#) | [fromPackage](#) | [matlab.unittest.selectors](#)

## Concepts

# matlab.unittest.selectors.HasBaseFolder

---

**Purpose** Selector for TestSuite elements determined by folder

**Description** The HasBaseFolder selector filters TestSuite array elements determined by the name of the folder that contains the file that defines the test class or function.

**Construction** `matlab.unittest.selectors.HasBaseFolder(f)` constructs a selector for TestSuite elements determined by the folder, `f`, which contains the file that defines the test class or function. You can specify the base folder as a string or as an instance of the `matlab.unittest.constraints.Constraint` class. If the specified base folder, `f`, is a string instead of a Constraint, the testing framework creates an `IsEqualTo` constraint with the input string, `f`, as the expected value.

For a test element to be included in the suite, the file that defines it must be contained in the specified base folder. For test classes defined in packages, the base folder is the parent of the top-level package folder. The base folder never contains any folders that start with '+' or '@'.

## Input Arguments

### **f** - Base folder

string | Constraint

Base folder specified as a string or a `matlab.unittest.constraints.Constraint` instance. The following conditions must be satisfied for the test element to be selected for the TestSuite:

- If `f` is a string, the test element's base folder must exactly match the specified folder.
- If `f` is a constraint, the test element's base folder must satisfy the specified constraint.

## Properties

### Constraint

Condition the base folder must satisfy to be included in the test suite, specified as an instance of the `matlab.unittest.constraints.Constraints` class.

## Copy Semantics

Value. To learn how value classes affect copy operations, see [Copying Objects in the MATLAB documentation](#).

## Examples

### Filter Test Suite by Base Folder

Create a folder, `MyTests`, in your current working folder. In this folder, create two subfolders, `Feature1` and `Feature2`.

In a new file, `Feature1_Test.m`, in the `Feature1` subfolder, create the following test class.

```
classdef Feature1_Test < matlab.unittest.TestCase
 methods (Test)
 function testA1(testCase)
 % test code
 end
 function testB1(testCase)
 % test code
 end
 end
end
```

In a new file, `Feature2_Test.m`, in the `Feature2` subfolder, create the following test class.

```
classdef Feature2_Test < matlab.unittest.TestCase
 methods (Test)
 function testA2(testCase)
 % test code
 end
 function testB2(testCase)
 % test code
 end
 end
end
```

# matlab.unittest.selectors.HasBaseFolder

---

```
 end
 end
end
```

If necessary, set your current working folder to the folder above `MyTests`. At the command prompt, create a test suite from the `MyTests` folder and examine the contents.

```
import matlab.unittest.TestSuite
import matlab.unittest.selectors.HasBaseFolder;
import matlab.unittest.constraints.ContainsSubstring;

suite = TestSuite.fromFolder('MyTests', 'IncludingSubfolders', true);
{suite.Name}

ans =

 'Feature1_Test/testA1' 'Feature1_Test/testB1' 'Feature2_Test/te
```

The suite contains the four tests from the two test files.

Select all test suite elements for classes that are defined in the `'Feature1'` folder.

```
s1 = suite.selectIf(HasBaseFolder(fullfile(pwd, 'MyTests', 'Feature1')));
{s1.Name}

ans =

 'Feature1_Test/testA1' 'Feature1_Test/testB1'
```

The filtered test suite contains only test elements from the `Feature1` folder.

Select all the test suite elements for classes that are defined in folders that do not contain the string `'Feature1'`, and then examine the contents.

```
s1 = suite.selectIf(HasBaseFolder(...
```

```
 fullfile(pwd, 'MyTests', 'Feature1')));
{s1.Name}

ans =

 'Feature2_Test/testA2' 'Feature2_Test/testB2'
```

The filtered test suite only contains test elements from the Feature2 folder.

Alternatively, to generate a filtered suite directly, pass the selector to the `TestSuite.fromFolder` method.

```
s1 = TestSuite.fromFolder('MyTests',...
 ~HasBaseFolder(ContainsSubstring('Feature1')),...
 'IncludingSubfolders',true);
```

## See Also

[selectIf](#) | [fromClass](#) | [fromFile](#) | [fromFolder](#) | [fromMethod](#) | [fromPackage](#) | [matlab.unittest.selectors](#)

## Concepts

# matlab.unittest.selectors.HasName

---

<b>Purpose</b>	Selector for TestSuite elements determined by name
<b>Description</b>	The HasName selector filters TestSuite array elements determined by the test element name.
<b>Construction</b>	<p><code>matlab.unittest.selectors.HasName(n)</code> constructs a selector for TestSuite elements determined by the test element name, <code>n</code>. You can specify the name as a string or as an instance of the <code>matlab.unittest.constraints.Constraint</code> class. If the specified name, <code>n</code>, is a string, the testing framework creates an <code>IsEqualTo</code> constraint with the input string, <code>n</code>, as the expected value.</p> <p>For a test element to be included in the suite, the test element must have the same name as the specified name.</p> <p><b>Input Arguments</b></p> <p><b>n - Test element name</b> <code>string</code>   <code>Constraint</code></p> <p>Test element name specified as a string or <code>matlab.unittest.constraints.Constraint</code> instance. The following conditions must be satisfied for the test element to be selected for the TestSuite:</p> <ul style="list-style-type: none"><li>• If <code>n</code> is a string, the test element's name must exactly match the specified name.</li><li>• If <code>n</code> is a constraint, the test element's name must satisfy the specified constraint.</li></ul>
<b>Properties</b>	<p><b>Constraint</b></p> <p>Condition the test element name must satisfy to be included in the test suite, specified as an instance of the <code>matlab.unittest.constraints.Constraints</code> class.</p>
<b>Copy Semantics</b>	Value. To learn how value classes affect copy operations, see Copying Objects in the MATLAB documentation.



## Examples

### Filter Test Suite by Name

Create the following test class in a file, `ExampleTest.m`, in your current working folder.

```
classdef ExampleTest < matlab.unittest.TestCase
 methods(Test)
 function testPathAdd(testCase)
 % test code
 end
 function testOne(testCase)
 % test code
 end
 function testTwo(testCase)
 % test code
 end
 end
end
```

At the command prompt, create a test suite from the `ExampleTest.m` file and examine the contents.

```
import matlab.unittest.TestSuite;
import matlab.unittest.selectors.HasName;
import matlab.unittest.constraints.EndsWithSubstring;

suite = TestSuite.fromFile('ExampleTest.m');
{suite.Name}

ans =

 'ExampleTest/testPathAdd' 'ExampleTest/testOne' 'ExampleTest/testTwo'
```

The suite contains three tests.

Select all the test suite elements that have the name `'ExampleTest/testPathAdd'`, and examine the contents.

```
s1 = suite.selectIf(HasName('ExampleTest/testPathAdd'));
```

# matlab.unittest.selectors.HasName

---

```
{s1.Name}
```

```
ans =
```

```
 'ExampleTest/testPathAdd'
```

The filtered test suite only contains one test element.

Select all the test suite elements that end in either 'One' or 'Two', and examine the contents.

```
s1 = suite.selectIf(HasName(EndsWithSubstring('One')) | ...
 HasName(EndsWithSubstring('Two')));
{s1.Name}
```

```
ans =
```

```
 'ExampleTest/testOne' 'ExampleTest/testTwo'
```

At the time of the test suite construction, create a test suite that only contains tests with the substring 'One'.

```
import matlab.unittest.constraints.ContainsSubstring;
s2 = TestSuite.fromFile('ExampleTest.m',...
 HasName(ContainsSubstring('One')))
```

```
s2 =
```

```
Test with properties:
```

```
 Name: 'ExampleTest/testOne'
 Parameterization: []
 SharedTestFixtures: []
```

## See Also

[selectIf](#) | [fromClass](#) | [fromFile](#) | [fromFolder](#) | [fromMethod](#) | [fromPackage](#) | [matlab.unittest.selectors](#)

## Concepts

**Purpose**

Semilogarithmic plot

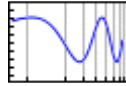
**Syntax**

```
semilogx(Y)
semilogx(X1,Y1,...)
semilogx(X1,Y1,LineStyle,...)
semilogx(...,'PropertyName',PropertyValue,...)
h = semilogx(...)
```

**Description**

semilogx plot data as logarithmic scales for the  $x$ -axis.

semilogx(Y) creates a plot using a base 10 logarithmic scale for the  $x$ -axis and a linear scale for the  $y$ -axis. It plots the columns of Y versus their index if Y contains real numbers. semilogx(Y) is equivalent to semilogx(real(Y), imag(Y)) if Y contains complex numbers. semilogx ignores the imaginary component in all other uses of this function.

semilogx(X1,Y1,...) plots all Yn versus Xn pairs. If only one of Xn or Yn is a matrix, semilogx plots the vector argument versus the rows or columns of the matrix, along the dimension of the matrix whose length matches the length of the vector. If the matrix is square, its columns plot against the vector if their lengths match.

semilogx(X1,Y1,LineStyle,...) plots all lines defined by the Xn,Yn,LineStyle triples. LineSpec determines line style, marker symbol, and color of the plotted lines.

semilogx(...,'PropertyName',PropertyValue,...) sets property values for all lineseries graphics objects created by semilogx.

h = semilogx(...) return a vector of handles to lineseries graphics objects, one handle per line.

## Tips

If you do not specify a color when plotting more than one line, `semilogx` automatically cycle through the colors and line styles in the order specified by the current axes `ColorOrder` and `LineStyleOrder` properties.

You can mix  $X_n, Y_n$  pairs with  $X_n, Y_n, \textit{LineStyle}$  triples; for example,

```
semilogx(X1, Y1, X2, Y2, LineSpec, X3, Y3)
```

If you attempt to add a `loglog`, `semilogx`, or `semilogy` plot to a linear axis mode graph with `hold on`, the axis mode remains as it is and the new data plots as linear.

## Renderer Support

The OpenGL renderer does not support logarithmic-scale axes. MATLAB automatically selects a different renderer when using logarithmic scaling. If you set the figure `Renderer` property to `opengl`, axis scales become linear. See the figure `Renderer` property for more information on renderers.

## Examples

### Logarithmic Scale for x-Axis

Create a plot with a logarithmic scale for the x-axis and a linear scale for the y-axis.

```
x = 0:1000;
y = log(x);

figure
semilogx(x,y)
```

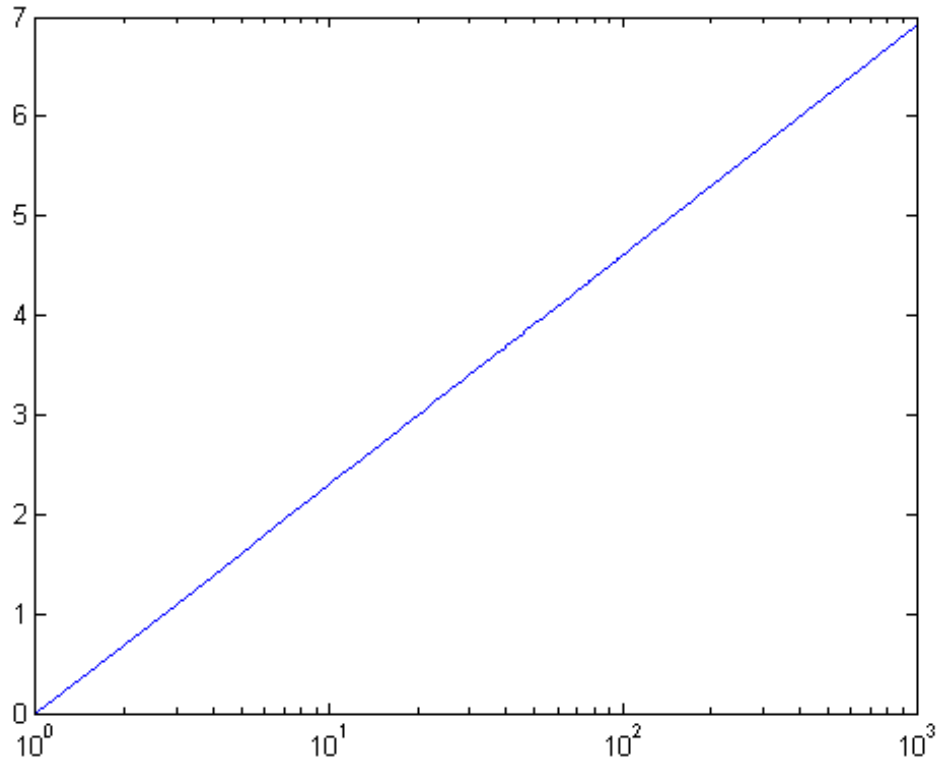
**See Also**

`line` | `LineSpec` | `loglog` | `plot` | `semilogy`

# semilogy

---

## Purpose

Semilogarithmic plot

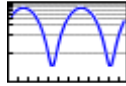

## Syntax

```
semilogy(Y)
semilogy(X1,Y1,...)
semilogy(X1,Y1,LineStyle,...)
semilogy(...,'PropertyName',PropertyValue,...)
h = semilogy(...)
```

## Description

semilogy plots data with logarithmic scale for the y-axis.

semilogy(Y) creates a plot using a base 10 logarithmic scale for the y-axis and a linear scale for the x-axis. It plots the columns of Y versus their index if Y contains real numbers. semilogy(Y) is equivalent to semilogy(real(Y), imag(Y)) if Y contains complex numbers. semilogy ignores the imaginary component in all other uses of this function.

semilogy(X1,Y1,...) plots all Yn versus Xn pairs. If only one of Xn or Yn is a matrix, semilogy plots the vector argument versus the rows or columns of the matrix, along the dimension of the matrix whose length matches the length of the vector. If the matrix is square, its columns plot against the vector if their lengths match.

semilogy(X1,Y1,LineStyle,...) plots all lines defined by the Xn,Yn,LineStyle triples. LineSpec determines line style, marker symbol, and color of the plotted lines.

semilogy(...,'PropertyName',PropertyValue,...) sets property values for all lineseries graphics objects created by semilogy.

h = semilogy(...) returns a vector of handles to lineseries graphics objects, one handle per line.

## Tips

If you do not specify a color when plotting more than one line, `semilogy` automatically cycle through the colors and line styles in the order specified by the current axes `ColorOrder` and `LineStyleOrder` properties.

You can mix  $X_n, Y_n$  pairs with  $X_n, Y_n, LineSpec$  triples; for example,

```
semilogy(X1, Y1, X2, Y2, LineSpec, X3, Y3)
```

If you attempt to add a `loglog`, `semilogx`, or `semilogy` plot to a linear axis mode graph with `hold on`, the axis mode remains as it is and the new data plots as linear.

## Renderer Support

The OpenGL renderer does not support logarithmic-scale axes. MATLAB automatically selects a different renderer when using logarithmic scaling. If you set the figure `Renderer` property to `opengl`, axis scales become linear. See the figure `Renderer` property for more information on renderers.

## Examples

### Logarithmic Scale for y-Axis

Create a plot with a logarithmic scale for the y-axis and a linear scale for the x-axis.

```
x = 0:0.1:10;
y = exp(x);
```

```
figure
semilogy(x,y);
```

# semilogy

---

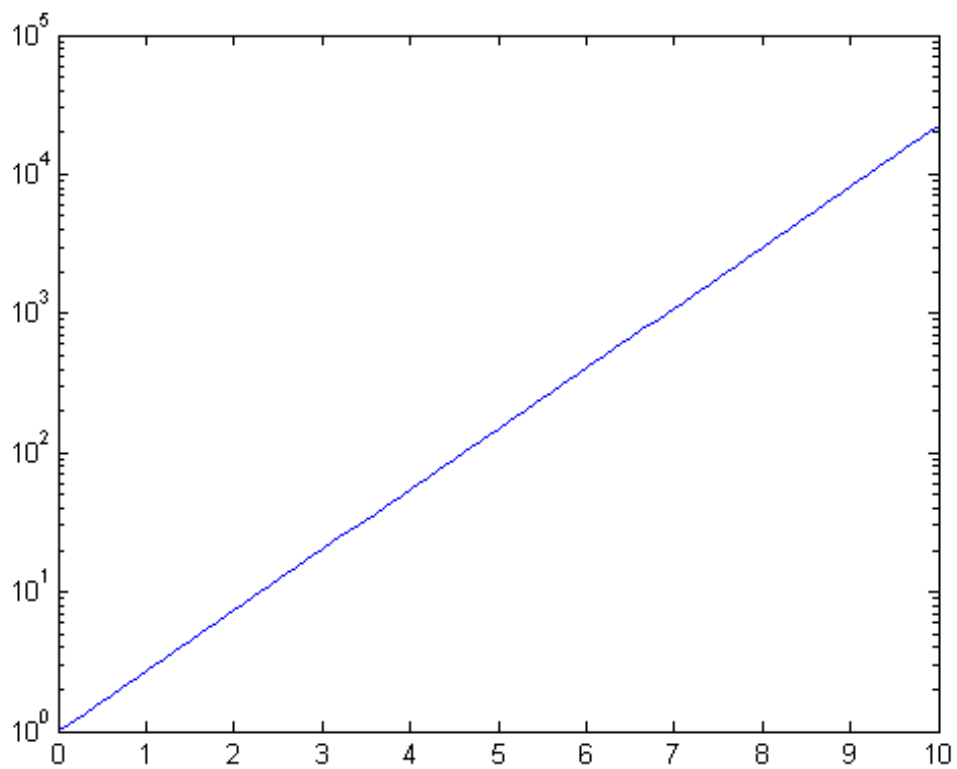

**See Also**      `line` | `LineSpec` | `loglog` | `plot` | `semilogx`



**Purpose** Send email message to address list

**Syntax**

```
sendmail(recipients,subject)
sendmail(recipients,subject,message)
sendmail(recipients,subject,message,attachments)
```

**Description** `sendmail(recipients,subject)` sends email to recipients with the specified subject. The recipients input is a string for a single address, or a cell array of strings for multiple addresses.

`sendmail(recipients,subject,message)` includes the specified message. If message is a string, `sendmail` automatically wraps text at 75 characters. To force a line break in the message text, use 10, as shown in the Examples. If message is a cell array of strings, each cell represents a new line of text.

`sendmail(recipients,subject,message,attachments)` attaches the files listed in the string or cell array attachments.

## Tips

- The `sendmail` function does not support HTML-formatted messages. However, you can send HTML files as attachments.
- If `sendmail` cannot determine your email address or outgoing SMTP mail server from your system registry, specify those settings using the `setpref` function. For example:

```
setpref('Internet','SMTP_Server','my_server.example.com');
setpref('Internet','E_mail','my_email@example.com');
```

To identify the SMTP server for the call to `setpref`, check the preferences for your electronic mail application, or consult your email system administrator. If you cannot easily determine the server name, try 'mail', which is a common default, such as:

```
setpref('Internet','SMTP_Server','mail');
```

- By default, the `sendmail` function does not support email servers that require authentication. To support these servers, change your

# sendmail

---

system settings and set preferences for the SMTP user name and password, with commands in the following form:

```
props = java.lang.System.getProperties();
props.setProperty('mail.smtp.auth', 'true');

setpref('Internet', 'SMTP_Username', 'myaddress@example.com');
setpref('Internet', 'SMTP_Password', 'mypassword');
```

- To override the default character encoding, set the preference for email character encoding as follows:

```
setpref('Internet', 'E_mail_Charset', encoding);
```

where *encoding* is a string specifying the character encoding, such as 'SJIS'.

## Examples

Send a message with two attachments to a hypothetical email address:

```
sendmail('user@otherdomain.com', ...
 'Test subject', 'Test message', ...
 {'folder/attach1.html', 'attach2.doc'});
```

---

Send a message with forced line breaks (using 10) to a hypothetical email address:

```
sendmail('user@otherdomain.com', 'New subject', ...
 ['Line1 of message' 10 'Line2 of message' 10 ...
 'Line3 of message' 10 'Line4 of message']);
```

The resulting message is:

```
Line1 of message
Line2 of message
Line3 of message
Line4 of message
```

Gmail™ servers require authentication and an encrypted connection (SSL) on port 465. Change your system settings to use your Gmail server and send a test message to your Gmail account:

```
% Modify these two lines to reflect
% your account and password.
myaddress = 'myaddress@gmail.com';
mypassword = 'mypassword';

setpref('Internet', 'E_mail', myaddress);
setpref('Internet', 'SMTP_Server', 'smtp.gmail.com');
setpref('Internet', 'SMTP_Username', myaddress);
setpref('Internet', 'SMTP_Password', mypassword);

props = java.lang.System.getProperties;
props.setProperty('mail.smtp.auth', 'true');
props.setProperty('mail.smtp.socketFactory.class', ...
 'javax.net.ssl.SSLSocketFactory');
props.setProperty('mail.smtp.socketFactory.port', '465');

sendmail(myaddress, 'Gmail Test', 'This is a test message.');
```

## Alternatives

On Windows systems with Microsoft Outlook®, you can send email directly through Outlook by accessing the COM server with actxserver. For an example, see Solution 1-RTY6J.

## See Also

getpref | setpref

## How To

- “Specify Proxy Server Settings for Connecting to the Internet”

# serial

---

**Purpose** Create serial port object

**Syntax**  
`obj = serial('port')`  
`obj = serial('port', 'PropertyName', PropertyValue, ...)`

**Description** `obj = serial('port')` creates a serial port object associated with the serial port specified by *port*. If *port* does not exist, or if it is in use, you will not be able to connect the serial port object to the device.

*Port* object name will depend upon the platform that the serial port is on. `instrhwinfo('serial')` provides a list of available serial ports. This list is an example of serial constructors on different platforms:

Platform	Serial Port Constructor
Linux and Linux 64	<code>serial('/dev/ttyS0');</code>
Mac OS X 64	<code>serial('/dev/tty.KeySerial1');</code>
Windows 32 and Windows 64	<code>serial('com1');</code>

`obj = serial('port', 'PropertyName', PropertyValue, ...)` creates a serial port object with the specified property names and property values. If an invalid property name or property value is specified, an error is returned and the serial port object is not created.

**Tips** When you create a serial port object, these property values are automatically configured:

- The **Type** property is given by `serial`.
- The **Name** property is given by concatenating `Serial` with the port specified in the `serial` function.
- The **Port** property is given by the port specified in the `serial` function.

You can specify the property names and property values using any format supported by the `set` function. For example, you can use property name/property value cell array pairs. Additionally, you can

specify property names without regard to case, and you can make use of property name completion. For example, the following commands are all valid on a Windows platform.

```
s = serial('COM1','BaudRate',4800);
s = serial('COM1','baudrate',4800);
s = serial('COM1','BAUD',4800);
```

Refer to [Configuring Property Values](#) for a list of serial port object properties that you can use with `serial`.

Before you can communicate with the device, it must be connected to `obj` with the `fopen` function. A connected serial port object has a `Status` property value of `open`. An error is returned if you attempt a read or write operation while the object is not connected to the device. You can connect only one serial port object to a given serial port.

## Examples

This example creates the serial port object `s1` associated with the serial port COM1 on a Windows platform.

```
s1 = serial('COM1');
```

The `Type`, `Name`, and `Port` properties are automatically configured.

```
get(s1,{'Type','Name','Port'})
ans =
 'serial' 'Serial-COM1' 'COM1'
```

To specify properties during object creation

```
s2 = serial('COM2','BaudRate',1200,'DataBits',7);
```

## See Also

[fclose](#) | [fopen](#) | [Name](#) | [Port](#) | [Status](#) | [Type](#)

# serialbreak

---

**Purpose** Send break to device connected to serial port

**Syntax** `serialbreak(obj)`  
`serialbreak(obj,time)`

**Description** `serialbreak(obj)` sends a break of 10 milliseconds to the device connected to the serial port object, `obj`.  
`serialbreak(obj,time)` sends a break to the device with a duration, in milliseconds, specified by `time`. Note that the duration of the break might be inaccurate under some operating systems.

**Tips** For some devices, the break signal provides a way to clear the hardware buffer.

Before you can send a break to the device, it must be connected to `obj` with the `fopen` function. A connected serial port object has a `Status` property value of `open`. An error is returned if you attempt to send a break while `obj` is not connected to the device.

`serialbreak` is a synchronous function, and blocks the command line until execution is complete.

If you issue `serialbreak` while data is being asynchronously written, an error is returned. In this case, you must call the `stopasync` function or wait for the write operation to complete.

**See Also** `fopen` | `stopasync` | `Status`

**Purpose** Set Handle Graphics object properties

**Syntax**

```
set(H, 'PropertyName', PropertyValue, ...)
set(H, a)
set(H, pn, pv, ...)
set(H, pn, MxN_pv)
a = set(h)
pv = set(h, 'PropertyName')
```

## Description

---

**Note** Do not use the `set` function on Java objects as it will cause a memory leak. For more information, see “Accessing Private and Public Data”

---

`set(H, 'PropertyName', PropertyValue, ...)` sets the named properties to the specified values on the object(s) identified by H. H can be a vector of handles, in which case `set` sets the properties' values for all the objects. If H is empty (that is, `[]`), `set` does nothing, but does not return an error or warning.

`set(H, a)` sets the named properties to the specified values on the object(s) identified by H. `a` is a structure array whose field names are the object property names and whose field values are the values of the corresponding properties.

`set(H, pn, pv, ...)` sets the named properties specified in the cell array `pn` to the corresponding value in the cell array `pv` for all objects identified in H.

`set(H, pn, MxN_pv)` sets `n` property values on each of `m` graphics objects, where `m = length(H)` and `n` is equal to the number of property names contained in the cell array `pn`. This allows you to set a given group of properties to different values on each object.

`a = set(h)` returns the user-settable properties and possible values for the object identified by `h`. `a` is a structure array whose field names are the object's property names and whose field values are the possible values of the corresponding properties. If you do not specify an output

argument, the MATLAB software displays the information on the screen. `h` must be scalar.

`pv = set(h, 'PropertyName')` returns the possible values for the named property. If the possible values are strings, `set` returns each in a cell of the cell array `pv`. For other properties, `set` returns a statement indicating that `PropertyName` does not have a fixed set of property values. If you do not specify an output argument, MATLAB displays the information on the screen. `h` must be scalar.

---

**Note** Consult the specific object page (figure, axes, and so on) to determine what properties you can set.

---

## Tips

You can use any combination of property name/property value pairs, structure arrays, and cell arrays in one call to `set`.

### Setting Property Units

Note that if you are setting both the `FontSize` and the `FontUnits` properties in one function call, you must set the `FontUnits` property first so that the MATLAB software can correctly interpret the specified `FontSize`. The same applies to figure and axes units — always set the `Units` property before setting properties whose values you want to be interpreted in those units. For example,

```
f = figure('Units','characters',...
 'Position',[30 30 120 35]);
```

## Examples

Set the `Color` property of the current axes to blue.

```
axes;
set(gca,'Color','b')
```

Change all the lines in a plot to black.

```
plot(peaks)
set(findobj('Type','line'),'Color','k')
```



You can define a group of properties in a structure to better organize your code. For example, these statements define a structure called `active`, which contains a set of property definitions used for the `uicontrol` objects in a particular figure. When this figure becomes the current figure, MATLAB changes the colors and enables the controls.

```
active.BackgroundColor = [.7 .7 .7];
active.Enable = 'on';
active.ForegroundColor = [0 0 0];

if gcf == control_fig_handle
 set(findobj(control_fig_handle,'Type','uicontrol'),active)
end
```

You can use cell arrays to set properties to different values on each object. For example, these statements define a cell array to set three properties,

```
PropName(1) = {'BackgroundColor'};
PropName(2) = {'Enable'};
PropName(3) = {'ForegroundColor'};
```

These statements define a cell array containing three values for each of three objects (i.e., a 3-by-3 cell array).

```
PropVal(1,1) = {[.5 .5 .5]};
PropVal(1,2) = {'off'};
PropVal(1,3) = {[.9 .9 .9]};
PropVal(2,1) = {[1 0 0]};
PropVal(2,2) = {'on'};
PropVal(2,3) = {[1 1 1]};
PropVal(3,1) = {[.7 .7 .7]};
PropVal(3,2) = {'on'};
PropVal(3,3) = {[0 0 0]};
```

Now pass the arguments to `set`,

```
set(H,PropName,PropVal)
```

where `length(H) = 3` and each element is the handle to a uicontrol.

## Setting Different Values for the Same Property on Multiple Objects

Suppose you want to set the value of the `Tag` property on five line objects, each to a different value. Note how the value cell array needs to be transposed to have the proper shape.

```
h = plot(rand(5));
set(h,{'Tag'},{'line1','line2','line3','line4','line5'})
```

## Setting Different Values for Multiple Properties on Multiple Objects

Suppose you want to set the values of the `Marker` and `Tag` properties on three different `stemseries` objects to different values. Each row of the value cell array corresponds to an object in `h` and contains two values, one for the `Marker` property and one for the `Tag` property.

```
x = 0:30;
y = [1.5*cos(x);4*exp(-.1*x).*cos(x);exp(.05*x).*cos(x)]';
h = stem(x,y);
set(h,{'Marker','Tag'},...
 {'o','Decaying Exponential';...
 'square','Growing Exponential';...
 '*','Steady State'})
```

## See Also

`findobj` | `gca` | `gcf` | `gco` | `gcbo` | `get`

**Purpose** Set property values for audioplayer object

**Syntax**

```
set(obj,Name,Value)
set(obj,cellOfNames,cellOfValues)
set(obj,structOfProperties)
settableProperties = set(obj)
```

**Description** `set(obj,Name,Value)` sets the named property to the specified value for the object `obj`.

`set(obj,cellOfNames,cellOfValues)` sets the properties listed in the cell array `cellOfNames` to the corresponding values in the cell array `cellOfValues`. Each cell array must contain the same number of elements.

`set(obj,structOfProperties)` sets the properties identified by each field of the structure array `structOfProperties` to the values of the associated fields.

`settableProperties = set(obj)` returns the names of the properties that you can set in a structure array. The field names of `settableProperties` are the property names.

**Tips** The `set` function allows combinations of property name/value pairs, cell array pairs, and structure arrays in the same function call.

**Examples** View the list of properties that you can set for an audioplayer object:

```
load handel.mat;
handelObj = audioplayer(y, Fs);
set(handelObj)
```

---

Set the `Tag` and `UserData` properties of an audioplayer object using a structure array:

```
newValues.Tag = 'My Tag';
newValues.UserData = {'My User Data', pi, [1 2 3 4]};
```

# audioplayer.set

---

```
load handel.mat;
handelObj = audioplayer(y, Fs);
set(handelObj, newValues)

% View the values all properties.
get(handelObj)
```

## Alternatives

To set the value of a single property, you can use dot notation. Reference each property as though it is a field of a structure array. For example, set the Tag property for an object called handelObj (as created in the Examples):

```
handelObj.Tag = 'This is my tag.';
```

This command is exactly equivalent to:

```
set(handelObj, 'Tag', 'This is my tag.');
```

## See Also

[audioplayer](#) | [get](#)

<b>Purpose</b>	Set property values for audiorecorder object
<b>Syntax</b>	<pre>set(obj,Name,Value) set(obj,cellOfNames,cellOfValues) set(obj,structOfProperties) settableProperties = set(obj)</pre>
<b>Description</b>	<p><code>set(obj,Name,Value)</code> sets the named property to the specified value for the object <code>obj</code>.</p> <p><code>set(obj,cellOfNames,cellOfValues)</code> sets the properties listed in the cell array <code>cellOfNames</code> to the corresponding values in the cell array <code>cellOfValues</code>. Each cell array must contain the same number of elements.</p> <p><code>set(obj,structOfProperties)</code> sets the properties identified by each field of the structure array <code>structOfProperties</code> to the values of the associated fields.</p> <p><code>settableProperties = set(obj)</code> returns the names of the properties that you can set in a structure array. The field names of <code>settableProperties</code> are the property names.</p>
<b>Tips</b>	The <code>set</code> function allows combinations of property name/value pairs, cell array pairs, and structure arrays in the same function call.
<b>Examples</b>	<p>View the list of properties that you can set for an audiorecorder object:</p> <pre>recorderObj = audiorecorder; set(recorderObj)</pre> <hr/> <p>Set the <code>Tag</code> and <code>UserData</code> properties of an audiorecorder object using a structure array:</p> <pre>newValues.Tag = 'My Tag'; newValues.UserData = {'My User Data', pi, [1 2 3 4]};</pre>

# audiorecorder.set

---

```
recorderObj = audiorecorder;
set(recorderObj, newValues)

% View the values all properties.
get(recorderObj)
```

## Alternatives

To set the value of a single property, you can use dot notation. Reference each property as though it is a field of a structure array. For example, set the Tag property for an object called recorderObj (as created in the Examples):

```
recorderObj.Tag = 'This is my tag.';
```

This command is exactly equivalent to:

```
set(recorderObj, 'Tag', 'This is my tag.');
```

## See Also

[audiorecorder](#) | [get](#)

<b>Purpose</b>	Set object or interface property to specified value
<b>Syntax</b>	<pre>h.set('pname',value) h.set('pname1',value1,'pname2',value2,...) set(h,...)</pre>
<b>Description</b>	<p><code>h.set('pname',value)</code> sets the property specified in the string <code>pname</code> to the given value.</p> <p><code>h.set('pname1',value1,'pname2',value2,...)</code> sets each property specified in the <code>pname</code> strings to the given value.</p> <p><code>set(h,...)</code> is an alternate syntax for the same operation.</p> <p>For information on how MATLAB converts workspace matrices to COM data types, see “Handling COM Data in MATLAB Software”.</p>
<b>Tips</b>	COM functions are available on Microsoft Windows systems only.
<b>Examples</b>	<p>Create an <code>mwsamp</code> control and use <code>set</code> to change the <code>Label</code> and <code>Radius</code> properties:</p> <pre>f = figure ('position', [100 200 200 200]); h = actxcontrol ('mwsamp.mwsampctrl.1', [0 0 200 200], f);  h.set('Label', 'Click to fire event', 'Radius', 40); h.invoke('Redraw');</pre> <p>Here is another way to do the same thing, only without <code>set</code> and <code>invoke</code>:</p> <pre>h.Label = 'Click to fire event'; h.Radius = 40; h.Redraw;</pre>
<b>See Also</b>	<code>get (COM)</code>   <code>inspect</code>   <code>isprop</code>   <code>addproperty</code>   <code>deleteproperty</code>

# set (hgsetget)

---

**Purpose** Assign property values to handle objects derived from hgsetget class

**Syntax**

```
set(H, 'PropertyName', value, ...)
set(H, pn, pv)
set(H, S)
S = set(h)
```

**Description**

`set(H, 'PropertyName', value, ...)` sets the named property to the specified value for the objects in the handle array `H`.

`set(H, pn, pv)` sets the named properties specified in the cell array of strings `pn` to the corresponding values in the cell array `pv` for all objects specified in `H`. The cell array `pn` must be 1-by-`n` (where `n` is the number of property names), but the cell array `pv` can be `m`-by-`n` where `m` is equal to `length(H)`. `set` updates each object with the associated set of values for the list of property names contained in.

`set(H, S)` sets the properties identified by each field name of struct `S` with the values contained in `S`. `S` is a struct whose field names are object property names.

`S = set(h)` returns the user-settable properties of scalar `h`. `S` is a struct whose field names are the object's property names and whose values are empty cell arrays.

Override the hgsetget class `setdisp` method to change how MATLAB displays this information.

**See Also** [handle](#) | [hgsetget](#) | [set](#) | [get \(hgsetget\)](#)

**How To**

- “Implementing a Set/Get Interface for Properties”



**Purpose** Set property values for video reader object

**Syntax**

```
set(obj,Name,Value)
set(obj,cellOfNames,cellOfValues)
set(obj,structOfProperties)
settableProperties = set(obj)
```

**Description** `set(obj,Name,Value)` sets the named property to the specified value for the object `obj`.

`set(obj,cellOfNames,cellOfValues)` sets the properties listed in the cell array `cellOfNames` to the corresponding values in the cell array `cellOfValues`. Each cell array must contain the same number of elements.

`set(obj,structOfProperties)` sets the properties identified by each field of the structure array `structOfProperties` to the values of the associated fields.

`settableProperties = set(obj)` returns the names of the properties that you can set in a structure array. The field names of `settableProperties` are the property names.

**Tips** The `set` function allows combinations of property name/value pairs, cell array pairs, and structure arrays in the same function call.

## **Examples** **View Settable Properties**

View the list of properties that you can set for a video reader object.

```
xyloObj = VideoReader('xylophone.mp4');
set(xyloObj)
```

```
General Settings:
 Tag
 UserData
```

## Set Object Properties

Set the `Tag` and `UserData` properties of a video reader object using a structure array.

```
newValues.Tag = 'My Tag';
newValues.UserData = {'My User Data', pi, [1 2 3 4]};
```

```
xyloObj = VideoReader('xylophone.mp4');
set(xyloObj, newValues)
```

View the values all properties.

```
get(xyloObj)
```

```
General Settings:
```

```
Duration = 4.7000
Name = xylophone.mp4
Path = matlabroot\toolbox\matlab\audiovideo
Tag = My Tag
Type = VideoReader
UserData = {'My User Data' [3.1416] [1 2 3 4]}
```

```
Video Settings:
```

```
BitsPerPixel = 24
FrameRate = 30
Height = 240
NumberOfFrames = 141
VideoFormat = RGB24
Width = 320
```

## Alternatives

To set the value of a single property, you can use dot notation. Reference each property as though it is a field of a structure array. For example, set the `Tag` property for a reader object called `xyloObj` (as created in the Examples):

```
xyloObj.Tag = 'This is my tag.';
```

This command is exactly equivalent to:

```
set(xyloObj, 'Tag', 'This is my tag.');
```

## See Also

VideoReader | get

# set (RandStream)

---

**Purpose** Set random number stream property

**Class** RandStream

**Syntax**

```
set(stream, 'PropertyName', Value)
set(stream, 'Property1', Value1, 'Property2', Value2, ...)
set(stream, A)
A = set(stream, 'Property')
set(stream, 'Property')
A = set(stream)
set(stream)
```

**Description**

`set(stream, 'PropertyName', Value)` sets the property 'PropertyName' of the random stream `stream` to the value `Value`.

`set(stream, 'Property1', Value1, 'Property2', Value2, ...)` sets multiple random stream property values with a single statement.

`set(stream, A)` where `A` is a structure whose field names are property names of the random stream `stream` sets the properties of `stream` named by each field with the values contained in those fields.

`A = set(stream, 'Property')` or `set(stream, 'Property')` displays possible values for the specified property of `stream`.

`A = set(stream)` or `set(stream)` displays or returns all writable properties of `stream` and their possible values.

**See Also** RandStream | get (RandStream) | rand | randn | randi

**Purpose** Configure or display serial port object properties

**Syntax**

```
set(obj)
props = set(obj)
set(obj, 'PropertyName')
props = set(obj, 'PropertyName')
set(obj, 'PropertyName', PropertyValue, ...)
set(obj, PN, PV)
set(obj, S)
```

**Description** `set(obj)` displays all configurable properties values for the serial port object, `obj`. If a property has a finite list of possible string values, then these values are also displayed.

`props = set(obj)` returns all configurable properties and their possible values for `obj` to `props`. `props` is a structure whose field names are the property names of `obj`, and whose values are cell arrays of possible property values. If the property does not have a finite set of possible values, then the cell array is empty.

`set(obj, 'PropertyName')` displays the valid values for *PropertyName* if it possesses a finite list of string values.

`props = set(obj, 'PropertyName')` returns the valid values for *PropertyName* to `props`. `props` is a cell array of possible string values or an empty cell array if *PropertyName* does not have a finite list of possible values.

`set(obj, 'PropertyName', PropertyValue, ...)` configures multiple property values with a single command.

`set(obj, PN, PV)` configures the properties specified in the cell array of strings `PN` to the corresponding values in the cell array `PV`. `PN` must be a vector. `PV` can be `m-by-n` where `m` is equal to the number of serial port objects in `obj` and `n` is equal to the length of `PN`.

`set(obj, S)` configures the named properties to the specified values for `obj`. `S` is a structure whose field names are serial port object properties, and whose field values are the values of the corresponding properties.

# set (serial)

---

## Tips

Refer to [Configuring Property Values](#) for a list of serial port object properties that you can configure with `set`.

You can use any combination of property name/property value pairs, structures, and cell arrays in one call to `set`. Additionally, you can specify a property name without regard to case, and you can make use of property name completion. For example, if `s` is a serial port object, then the following commands are all valid.

```
set(s, 'BaudRate')
set(s, 'baudrate')
set(s, 'BAUD')
```

## Examples

This example illustrates some of the ways you can use `set` to configure or return property values for the serial port object `s`, on a Windows platform.

```
s = serial('COM1');
set(s, 'BaudRate', 9600, 'Parity', 'even')
set(s, {'StopBits', 'RecordName'}, {2, 'sydney.txt'})
set(s, 'Parity')
[{none} | odd | even | mark | space]
```

## See Also

`get`

**Purpose**

Set properties of tscollection object

**Syntax**

```
set(tsc, 'Property', Value)
set(tsc, 'Property1', Value1, 'Property2', Value2, ...)
set(tsc, 'Property')
```

**Description**

set(tsc, 'Property', Value) sets the property 'Property' of the tscollection tsc to the value Value. The following syntax is equivalent:

```
tsc.Property = Value
```

set(tsc, 'Property1', Value1, 'Property2', Value2, ...) sets multiple property values for tsc with a single statement.

set(tsc, 'Property') displays values for the specified property in the time-series collection tsc.

set(tsc) displays all properties and values of the tscollection object tsc.

**See Also**

get (tscollection)

# setabstime (tscollection)

---

**Purpose** Set times of tscollection object as date strings

**Syntax**

```
tsc = setabstime(tsc,Times)
tsc = setabstime(tsc,Times,format)
```

**Description** `tsc = setabstime(tsc,Times)` sets the times in `tsc` using the date strings `Times`. `Times` must be either a cell array of strings, or a char array containing valid date or time values in the same date format.

`tsc = setabstime(tsc,Times,format)` specifies the date-string format used in `Times` explicitly.

**Examples** **1** Create a `tscollection` object.

```
tsc = tscollection(timeseries(rand(3,1)))
```

**2** Set the absolute time vector.

```
tsc = setabstime(tsc,{'12-DEC-2005 12:34:56',...
 '12-DEC-2005 13:34:56','12-DEC-2005 14:34:56'})
```

**See Also** `datestr` | `tscollection` | `getabstime (tscollection)`



**Purpose** Specify application-defined data

**Syntax** `setappdata(h,name,val)`

**Description** `setappdata(h,name,val)` stores values of `val` in a GUI. The first argument, `h`, is a handle to a component in the GUI. The second argument, `name`, is a string that serves as a name for the data. The values of `h` and `name` uniquely identify the location of the data so that you can retrieve the values of `val` elsewhere in your code using the `getappdata` function.

---

**Note** `h` can be a handle to any GUI component except an ActiveX component.

---

**See Also** `getappdata` | `isappdata` | `rmappdata`

**Concepts**

- “Share Data Among Callbacks”

# setdiff

---

**Purpose** Set difference of two arrays

**Syntax**

```
C = setdiff(A,B)
C = setdiff(A,B,'rows')
[C,ia] = setdiff(A,B)
[C,ia] = setdiff(A,B,'rows')

[C,ia] = setdiff(__,setOrder)
[C,ia] = setdiff(A,B,'legacy')
[C,ia] = setdiff(A,B,'rows','legacy')
```

**Description** `C = setdiff(A,B)` returns the data in A that is not in B.

- If A and B are numeric arrays, logical arrays, character arrays, categorical arrays, or cell arrays of strings, then `setdiff` returns the values in A that are not in B. The values of C are in sorted order.
- If A and B are tables, then `setdiff` returns the rows from A that are not in B, with repetitions removed. The rows of table C are in sorted order.

`C = setdiff(A,B,'rows')` treats each row of A and each row of B as single entities and returns the rows from A that are not in B. The rows of C are in sorted order.

The 'rows' option does not support cell arrays.

`[C,ia] = setdiff(A,B)` also returns the index vector `ia`.

- If A and B are numeric arrays, logical arrays, character arrays, categorical arrays, or cell arrays of strings, then `C = A(ia)`.
- If A and B are tables, then `C = A(ia,:)`.

`[C,ia] = setdiff(A,B,'rows')` also returns the index vector `ia`, such that `C = A(ia,:)`.

`[C,ia] = setdiff(___,setOrder)` returns `C` in a specific order using any of the input arguments in the previous syntaxes. `setOrder='sorted'` returns the values (or rows) of `C` in sorted order. `setOrder='stable'` returns the values (or rows) of `C` in the same order as `A`. If no value is specified, the default is `'sorted'`.

`[C,ia] = setdiff(A,B,'legacy')` and `[C,ia] = setdiff(A,B,'rows','legacy')` preserve the behavior of the `setdiff` function from R2012b and prior releases.

The `'legacy'` option does not support categorical arrays or tables.

## Input Arguments

### A,B - Input arrays

numeric arrays | logical arrays | character arrays | categorical arrays  
| cell arrays of strings | tables

Input arrays, specified as numeric arrays, logical arrays, character arrays, categorical arrays, cell arrays of strings, or tables.

`A` and `B` must belong to the same class with the following exceptions:

- `logical`, `char`, and all numeric classes can combine with `double` arrays.
- Cell arrays of strings can combine with `char` arrays.
- Categorical arrays can combine with cell arrays of strings or single strings.

If `A` and `B` are both ordinal categorical arrays, they must have the same sets of categories, including their order. If neither `A` nor `B` are ordinal, they need not have the same sets of categories, and the comparison is performed using the category names. In this case, the categories of `C` are the sorted union of the categories from `A` and `B`.

If you specify the `'rows'` option, `A` and `B` must have the same number of columns.

If `A` and `B` are tables, they must have the same variable names. Conversely, the row names do not matter. Two rows that have the same values, but different names, are considered equal.

# setdiff

Furthermore, A and B can be objects with the following class methods:

- sort (or sortrows for the 'rows' option)
- eq
- ne

The object class methods must be consistent with each other. These objects include heterogeneous arrays derived from the same root class.

## setOrder - Order flag

'sorted' (default) | 'stable'

Order flag, specified as 'sorted' or 'stable', indicates the order of the values (or rows) in C.

Order Flag	Meaning
'sorted'	The values (or rows) in C return in sorted order. For example: <code>C = setdiff([4 1 3 2],[2 1],'sorted')</code> returns <code>C = [3 4]</code> .
'stable'	The values (or rows) in C return in the same order as in A. For example: <code>C = setdiff([4 1 3 2],[2 1],'stable')</code> returns <code>C = [4 3]</code> .

## Output Arguments

### C - Difference of A and B

vector | matrix | table

Difference of A and B, returned as a vector, matrix, or table. If the inputs A and B are tables, the order of the variables in the resulting table, C, is the same as the order of the variables in A.

The following describes the shape of C when the inputs are vectors or matrices and when the 'legacy' flag is not specified:

- If the 'rows' flag is not specified and A is a row vector, then C is a row vector.

- If the 'rows' flag is not specified and A is not a row vector, then C is a column vector.
- If the 'rows' flag is specified, then C is a matrix containing the rows of A that are not in B.
- If all the values (or rows) of A are also in B, then C is an empty matrix.

The class of C is the same as the class of A, unless:

- A is a character array and B is a cell array of strings, in which case C is a cell array of strings.
- A is a cell array of strings or single string and B is a categorical array, in which case C is a categorical array.

### **ia - Index to A**

column vector

Index to A, returned as a column vector when the 'legacy' flag is not specified. `ia` identifies the values (or rows) in A that are not in B. If there is a repeated value (or row) appearing exclusively in A, then `ia` contains the index to the first occurrence of the value (or row).

## **Examples**

### **Difference of Two Vectors**

Define two vectors with values in common.

```
A = [3 6 2 1 5 1 1]; B = [2 4 6];
```

Find the values in A that are not in B.

```
C = setdiff(A,B)
```

```
C =
```

```
 1 3 5
```

### **Difference of Two Tables**

Define two tables with rows in common.

# setdiff

---

```
A = table([1:5]', ['A'; 'B'; 'C'; 'D'; 'E'], logical([0;1;0;1;0]))
B = table([1:2:10]', ['A'; 'C'; 'E'; 'G'; 'I'], logical(zeros(5,1)))
```

A =

Var1	Var2	Var3
1	A	false
2	B	true
3	C	false
4	D	true
5	E	false

B =

Var1	Var2	Var3
1	A	false
3	C	false
5	E	false
7	G	false
9	I	false

Find the rows in A that are not in B.

```
C = setdiff(A,B)
```

C =

Var1	Var2	Var3
2	B	true
4	D	true

## **Difference of Two Vectors and Indices to Different Values**

Define two vectors with values in common.

```
A = [3 6 2 1 5 1 1]; B = [2 4 6];
```

Find the values in A that are not in B as well as the index vector `ia`, such that `C = A(ia)`.

```
[C,ia] = setdiff(A,B)
```

```
C =
```

```
 1 3 5
```

```
ia =
```

```
 4
 1
 5
```

### Difference of Two Tables and Indices to Different Rows

Define a table, A, of gender, age, and height for five people.

```
A = table(['M';'M';'F';'M';'F'],[27;52;31;46;35],[74;68;64;61;64],...
'VariableNames',{'Gender' 'Age' 'Height'},...
'RowNames',{'Ted' 'Fred' 'Betty' 'Bob' 'Judy'})
```

```
A =
```

	Gender	Age	Height
	-----	---	-----
Ted	M	27	74
Fred	M	52	68
Betty	F	31	64
Bob	M	46	61
Judy	F	35	64

Define a table, B, with the same variables as A.

```
B = table(['F';'M';'F';'F'],[64;68;62;58],[31;47;35;23],...
'VariableNames',{'Gender' 'Height' 'Age'},...)
```

# setdiff

---

```
'RowNames',{ 'Meg' 'Joe' 'Beth' 'Amy' })
```

```
B =
```

	Gender	Height	Age
	-----	-----	---
Meg	F	64	31
Joe	M	68	47
Beth	F	62	35
Amy	F	58	23

Find the rows in A that are not in B, as well as the index vector ia, such that  $C = A(ia, :)$ .

```
[C,ia] = setdiff(A,B)
```

```
C =
```

	Gender	Age	Height
	-----	---	-----
Judy	F	35	64
Ted	M	27	74
Bob	M	46	61
Fred	M	52	68

```
ia =
```

```
5
1
4
2
```

The rows of C are in sorted order first by Gender and next by Age.

## **Difference of Rows in Two Matrices**

Define two matrices with rows in common.



```
A = [7 9 7; 0 0 0; 7 9 7; 5 5 5; 1 4 5];
B = [0 0 0; 5 5 5];
```

Find the rows from A that are not in B as well as the index vector `ia`, such that `C = A(ia,:)`.

```
[C,ia] = setdiff(A,B,'rows')
```

```
C =
```

```
 1 4 5
 7 9 7
```

```
ia =
```

```
 5
 1
```

### Difference of Two Vectors with Specified Output Order

Use the `setOrder` argument to specify the ordering of the values in C.

Specify `'stable'` or `'sorted'` when the order of the values in C are important.

```
A = [3 6 2 1 5 1 1]; B = [2 4 6];
[C,ia] = setdiff(A,B,'stable')
```

```
C =
```

```
 3 1 5
```

```
ia =
```

```
 1
 4
 5
```

Alternatively, you can specify `'sorted'` order.

# setdiff

---

```
[C,ia] = setdiff(A,B,'sorted')

C =

 1 3 5

ia =

 4
 1
 5
```

## Difference of Vectors Containing NaNs

Define two vectors containing NaN.

```
A = [5 NaN NaN]; B = [5 NaN];
```

Find the set difference of A and B.

```
C = setdiff(A,B)
```

```
C =

 NaN NaN
```

setdiff treats NaN values as distinct.

## Cell Array of Strings with Trailing White Space

Create a cell array of strings, A.

```
A = {'dog','cat','fish','horse'};
```

Create a cell array of strings, B, where some of the strings have trailing white space.

```
B = {'dog ','cat','fish ','horse'};
```

Find the strings in A that are not in B.

```
[C,ia] = setdiff(A,B)
```

```
C =
```

```
 'dog' 'fish'
```

```
ia =
```

```
 1
 3
```

setdiff treats trailing white space in cell arrays of strings as distinct characters.

### **Difference of Char and Cell Array of Strings**

Create a character array, A.

```
A = ['cat'; 'dog'; 'fox'; 'pig'];
class(A)
```

```
ans =
```

```
char
```

Create a cell array of strings, B.

```
B={'dog', 'cat', 'fish', 'horse'};
class(B)
```

```
ans =
```

```
cell
```

Find the strings in A that are not in B.

```
C = setdiff(A,B)
```

# setdiff

---

```
C =

 'fox'
 'pig'
```

The result, `C`, is a cell array of strings.

```
class(C)
```

```
ans =
```

```
cell
```

## Preserve Legacy Behavior of setdiff

Use the `'legacy'` flag to preserve the behavior of `setdiff` from R2012b and prior releases in your code.

Find the difference of `A` and `B` with the current behavior.

```
A = [3 6 2 1 5 1 1]; B = [2 4 6];
[C1,ia1] = setdiff(A,B)
```

```
C1 =

 1 3 5
```

```
ia1 =
```

```
 4
 1
 5
```

Find the difference of `A` and `B`, and preserve the legacy behavior.

```
[C2,ia2] = setdiff(A,B,'legacy')
```

```
C2 =
```

```
 1 3 5
ia2 =
 7 1 5
```

**Tips**

- To find the set difference with respect to a subset of variables from a table, you can use column subscripting. For example, you can use `setdiff(A(:,vars),B(:,vars))`, where *vars* is a positive integer, a vector of positive integers, a variable name, a cell array of variable names, or a logical vector.

**See Also**

`unique` | `intersect` | `ismember` | `issorted` | `union` | `setxor` | `sort`

**Concepts**

- “Combine Categorical Arrays”

# Tiff.setDirectory

---

**Purpose** Make specified IFD current IFD

**Syntax** `tiffobj.setDirectory(dirNum)`

**Description** `tiffobj.setDirectory(dirNum)` sets the image file directory (IFD) specified by `dirNum` as the current IFD. Tiff object methods operate on the current IFD. The directory index number is one-based.

**Examples** Open a TIFF file and move to an IFD in the file by specifying its index number. The TIFF file should contain multiple images.

```
t = Tiff('example.tif', 'r');
t.setDirectory(2);
t.close();
```

**References** This method corresponds to the `TIFFSetDirectory` function in the LibTIFF C API. To use this method, you must be familiar with the TIFF specification and technical notes. View this documentation at [LibTIFF - TIFF Library and Utilities](#).

**See Also** `Tiff.currentDirectory` | `Tiff.nextDirectory`

**Tutorials**

- “Exporting Image Data and Metadata to TIFF Files”
- “Reading Image Data and Metadata from TIFF Files”

<b>Purpose</b>	Override to change command window display
<b>Syntax</b>	setdisp(H)
<b>Description</b>	setdisp(H) called by set when set is called with no output arguments and a single input argument that is a handle array. Override this hgsetget class method in a subclass to change how property information is displayed in the command window.
<b>See Also</b>	hgsetget   set (hgsetget)
<b>How To</b>	<ul style="list-style-type: none"><li>• “Implementing a Set/Get Interface for Properties”</li></ul>

# setenv

---

**Purpose** Set environment variable

**Syntax** `setenv(name,value)`  
`setenv(name)`

**Description** `setenv(name,value)` sets the value of an environment variable belonging to the underlying operating system. Inputs `name` and `value` are both strings. If `name` already exists as an environment variable, then `setenv` replaces its current value with the string given in `value`. If `name` does not exist, `setenv` creates a new environment variable called `name` and assigns `value` to it.

`setenv(name)` is equivalent to `setenv(name, '')` and assigns a null value to the variable `name`. On the Microsoft Windows platform, this is equivalent to undefining the variable. On most UNIX platforms, it is possible to have an environment variable defined as empty.

The maximum number of characters in `name` is  $2^{15} - 2$  (or 32766). If `name` contains the character `=`, `setenv` throws an error. The behavior of environment variables with `=` in the name is not well-defined.

On all platforms, `setenv` passes the `name` and `value` strings to the operating system unchanged. Special characters such as `;`, `/`, `:`, `$`, `%`, etc. are left unexpanded and intact in the variable value.

Values assigned to variables using `setenv` are picked up by any process that is spawned using the MATLAB `system`, `unix`, `dos` or `!` functions. You can retrieve any value set with `setenv` by using `getenv(name)`.

**Examples** `% Set and retrieve a new value for the environment variable TEMP:`

```
setenv('TEMP', 'C:\TEMP');
getenv('TEMP')
```

`% Append the Perl\bin folder to your system PATH variable:`

```
setenv('PATH', [getenv('PATH') 'D:\Perl\bin']);
```

**See Also** `getenv` | `system` | `unix` | `dos` | `!`



**Purpose**

Assign values to structure array field

**Syntax**

```
s = setfield(s, 'field', value)
s =
setfield(s, {sIndx1, ..., sIndxM}, 'field', {fIndx1, ..., fIndxN}, value)
```

**Description**

`s = setfield(s, 'field', value)`, where `s` is a 1-by-1 structure, sets the contents of the specified field, equivalent to `s.field = value`. If `s` does not contain the specified `field`, the `setfield` function creates the field and assigns the specified value. Pass field references as strings.

```
s =
setfield(s, {sIndx1, ..., sIndxM}, 'field', {fIndx1, ..., fIndxN}, value)
```

sets the contents of the specified field, equivalent to `s(sIndx1, ..., sIndxM).field(fIndx1, ..., fIndxN) = value`. The `setfield` function supports multiple sets of `field` and `fIndx` inputs. If structure `s` or any of the fields is a nonscalar structure, the `Indx` inputs associated with that input are required. Otherwise, the `Indx` inputs are optional. If you specify a single colon operator for an index input, enclose it in single quotation marks: `' : '`.

**Tips**

- For most cases, add data to a structure array by indexing rather than using the `setfield` function. For more information, see “Access Data in a Structure Array” and “Generate Field Names from Variables”.
- Call `setfield` to simplify references to structure arrays with nested fields, as shown in the Examples section.

**Examples**

Add values to a structure that contains nested fields:

```
grades = [];
level = 5;
semester = 'Fall';
subject = 'Math';
student = 'John_Doe';
fieldnames = {semester subject student};
newGrades_Doe = [85, 89, 76, 93, 85, 91, 68, 84, 95, 73];
```

# setfield

---

```
grades = setfield(grades, {level}, ...
 fieldnames{:}, {10, 21:30}, ...
 newGrades_Doe);

% View the new contents.
grades(level).(semester).(subject).(student)(10, 21:30)
```

---

Using the structure defined in the previous example, remove the tenth row of the specified field:

```
grades = setfield(grades, {level}, fieldnames{:}, {10,':'}, []);
```

## See Also

[getfield](#) | [fieldnames](#) | [isfield](#) | [orderfields](#) | [rmfield](#)

## How To

- “Generate Field Names from Variables”
- “Access Data in a Structure Array”

**Purpose** Set component position in pixels

**Syntax** `setpixelposition(handle,position)`  
`setpixelposition(handle,position,recursive)`

**Description** `setpixelposition(handle,position)` sets the position of the component specified by `handle`, to the specified position relative to its parent. `position` is a four-element vector that specifies the location and size of the component: [pixels from left, pixels from bottom, pixels across, pixels high].

`setpixelposition(handle,position,recursive)` sets the position as above. If Boolean `recursive` is true, the position is set relative to the parent figure of `handle`.

**Examples** This example first creates a push button within a panel.

```
f = figure('Position',[300 300 300 200]);
p = uipanel('Position',[.2 .2 .6 .6]);
h1 = uicontrol(p,'Style','PushButton',...
 'Units','normalized',...
 'String','Push Button',...
 'Position',[.1 .1 .5 .2]);
```

# setpixelposition

---

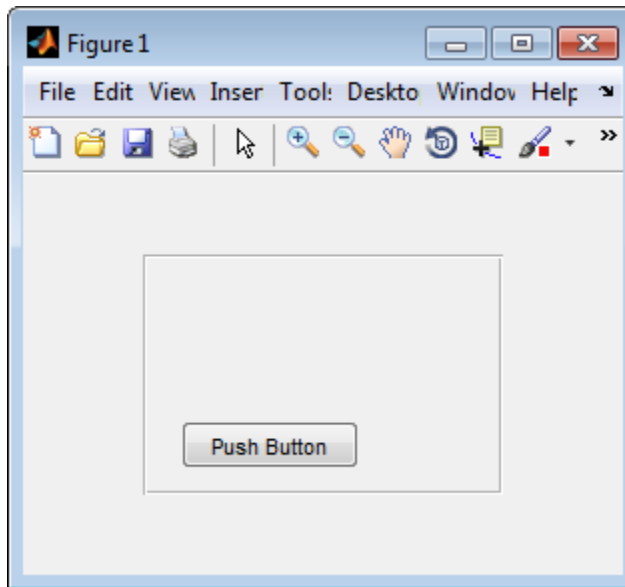

The example then retrieves the position of the push button and changes its position with respect to the panel.

```
pos1 = getpixelposition(h1);
setpixelposition(h1,pos1 + [10 10 25 25]);
```

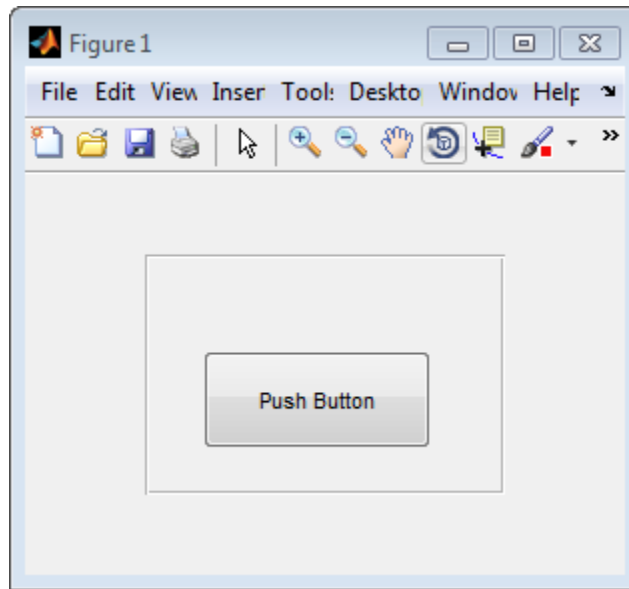

**See Also** [getpixelposition](#) | [uicontrol](#) | [uipanel](#)

# setpref

---

## Purpose

Set preference

## Syntax

```
setpref('group','pref',val)
setpref('group',{'pref1','pref2',...,'prefn'},{val1,val2,...,valn})
```

## Description

`setpref('group','pref',val)` sets the preference specified by `group` and `pref` to the value `val`. Individual preference values can be any MATLAB data type, including numeric types, strings, cell arrays, structures, and objects. Setting a preference that does not yet exist causes it to be created.

`group` labels a related collection of preferences. You can choose any name that is a legal variable name, and is descriptive enough to be unique, e.g., `'MathWorks_GUIDE_ApplicationPrefs'`. The input argument `pref` identifies an individual preference in that group, and must be a legal variable name.

`setpref('group',{'pref1','pref2',...,'prefn'},{val1,val2,...,valn})` sets each preference specified in the cell array of names to the corresponding value.

---

**Note** Preference values are persistent and maintain their values between MATLAB sessions. Where they are stored is system dependent.

---

## Examples

Use `addpref` to create a preference group called `mytoolbox` and a preference within it called `version`, and then modify the contents of `version` using `setpref`:

```
addpref('mytoolbox','version','1.0')
getpref('mytoolbox','version')
```

```
ans =
1.0
```

```
setpref('mytoolbox','version',{'1.0','beta'})
getpref('mytoolbox','version')
```

```
ans =
 '1.0' 'beta'
```

## See Also

addpref | getpref | ispref | rmpref | uigetpref | uisetpref

# setstr

---

**Purpose** Set string flag

---

**Note** setstr is not recommended. Use char instead.

---

**Description** This MATLAB 4 function has been renamed char in MATLAB 5.



<b>Purpose</b>	Make subIFD specified by byte offset current IFD
<b>Syntax</b>	<code>tiffobj.setSubDirectory(offset)</code>
<b>Description</b>	<code>tiffobj.setSubDirectory(offset)</code> sets the subimage file directory (subIFD) specified by <code>offset</code> the current IFD. The <code>offset</code> value is given in bytes. Use this method when you want to access subIFDs linked through the SubIFD tag.
<b>Examples</b>	<p><b>Set Subimage File Directory</b></p> <p>Open a TIFF file and read the value of the SubIFD tag in the current IFD. The SubIFD tag contains byte offsets that specify the location of subIFDs in the IFD. The TIFF file should contain subIFDs.</p> <pre>t = Tiff('example.tif', 'r');</pre> <p>Read the value of the SubIFD tag to get subdirectory offsets.</p> <pre>offsets = t.getTag('SubIFD');</pre> <p>Set one of the subdirectories (if more than one) as the current directory.</p> <pre>t.setSubDirectory(offsets(1)); t.close();</pre>
<b>References</b>	This method corresponds to the <code>TIFFSetSubDirectory</code> function in the LibTIFF C API. To use this method, you must be familiar with the TIFF specification and technical notes. View this documentation at <a href="#">LibTIFF - TIFF Library and Utilities</a> .
<b>See Also</b>	<code>Tiff.setDirectory</code>
<b>Tutorials</b>	<ul style="list-style-type: none"><li>• “Exporting Image Data and Metadata to TIFF Files”</li><li>• “Reading Image Data and Metadata from TIFF Files”</li></ul>

# Tiff.setTag

---

**Purpose** Set value of tag

**Syntax** `tiffobj.setTag(tagId,tagValue)`  
`tiffobj.setTag(tagStruct)`

**Description** `tiffobj.setTag(tagId,tagValue)` sets the value of the TIFF tag specified by `tagId` to the value specified by `tagValue`. You can specify `tagId` as a character string ('ImageWidth') or using the numeric tag identifier defined by the TIFF specification (256). To see a list of all the tags with their numeric identifiers, view the value of the Tiff object `TagID` property. Use the `TagID` property to specify the value of a tag. For example, `Tiff.TagID.ImageWidth` is equivalent to the tag's numeric identifier.

`tiffobj.setTag(tagStruct)` sets the values of all of the tags with `name/value` fields in `tagStruct`. The names of fields in `tagstruct` must be the name of TIFF tags.

---

**Note** If you are modifying a tag rather than creating it, you must use the `Tiff.rewriteDirectory` method after using the `Tiff.setTag` method.

---

## Examples **Set Tag Values**

Write TIFF tags and image data to a new TIFF file.

Read sample data into an array, `imdata`. Create a `Tiff` object associated with a new file, `myfile.tif`, and open the file for writing.

```
imdata = imread('example.tif');
t = Tiff('myfile.tif','w');
```

Set tag values by specifying the numeric tag identifier. Use the `TagID` property to obtain the tag identifier.

```
t.setTag(Tiff.TagID.ImageLength,size(imdata,1));
```

```
t.setTag(Tiff.TagID.ImageWidth, size(imdata,2));
```

Set tag values by specifying the tag name.

```
t.setTag('Photometric', Tiff.Photometric.RGB);
t.setTag('PlanarConfiguration', Tiff.PlanarConfiguration.Chunky);
```

Create a structure with fields named after TIFF tags and assign values to the fields. Pass this structure to the `setTag` method to set the values of these tags.

```
tagStruct.BitsPerSample = 8;
tagStruct.SamplesPerPixel = 3;
tagStruct.TileWidth = 128;
tagStruct.TileLength = 128;
tagStruct.Compression = Tiff.Compression.JPEG;
tagStruct.Software = 'MATLAB';
t.setTag(tagStruct);
```

Write the image data to the TIFF file.

```
t.write(imdata);
t.close();
```

## References

This method corresponds to the `TIFFSetField` function in the LibTIFF C API. To use this method, you must be familiar with the TIFF specification and technical notes. View this documentation at [LibTIFF - TIFF Library and Utilities](#).

## See Also

`Tiff.getTag`

## Tutorials

- “Exporting Image Data and Metadata to TIFF Files”
- “Reading Image Data and Metadata from TIFF Files”

# settimeseriesnames

---

**Purpose** Change name of `timeseries` object in `tscollection`

**Syntax** `tsc = settimeseriesnames(tsc,old,new)`

**Description** `tsc = settimeseriesnames(tsc,old,new)` replaces the old name of `timeseries` object with the new name in `tsc`.

**See Also** `tscollection`

**Purpose**

Set exclusive OR of two arrays

**Syntax**

```
C = setxor(A,B)
C = setxor(A,B,'rows')
[C,ia,ib] = setxor(A,B)
[C,ia,ib] = setxor(A,B,'rows')

[C,ia,ib] = setxor(__,setOrder)

[C,ia,ib] = setxor(A,B,'legacy')

[C,ia,ib] = setxor(A,B,'rows','legacy')
```

**Description**

`C = setxor(A,B)` returns the data of `A` and `B` that are not in their intersection (the symmetric difference).

- If `A` and `B` are numeric arrays, logical arrays, character arrays, categorical arrays, or cell arrays of strings, then `setxor` returns the values that occur in `A` or `B`, but not both. The values of `C` are in sorted order.
- If `A` and `B` are tables, then `setxor` returns the rows that occur in one or the other of the two tables, but not both. The rows of table `C` are in sorted order.

`C = setxor(A,B,'rows')` treats each row of `A` and each row of `B` as single entities and returns the rows of matrices `A` and `B` that are not in their intersection. The rows of `C` are in sorted order.

The `'rows'` option does not support cell arrays.

`[C,ia,ib] = setxor(A,B)` also returns index vectors `ia` and `ib`.

- If `A` and `B` are numeric arrays, logical arrays, character arrays, categorical arrays, or cell arrays of strings, then `C` is a sorted combination of the elements `A(ia)` and `B(ib)`.

- If A and B are tables, then C is a sorted combination of the rows of A(ia,:) and B(ib,:).

`[C,ia,ib] = setxor(A,B,'rows')` also returns index vectors `ia` and `ib`, such that C is a sorted combination of the rows of A(ia,:) and B(ib,:).

`[C,ia,ib] = setxor(___,setOrder)` returns C in a specific order using any of the input arguments in the previous syntaxes. `setOrder='sorted'` returns the values (or rows) of C in sorted order. `setOrder='stable'` returns the values (or rows) of C in the same order as A and B. If no value is specified, the default is 'sorted'.

`[C,ia,ib] = setxor(A,B,'legacy')` and `[C,ia,ib] = setxor(A,B,'rows','legacy')` preserve the behavior of the `setxor` function from R2012b and prior releases.

The 'legacy' option does not support categorical arrays or tables.

## Input Arguments

### A,B - Input arrays

numeric arrays | logical arrays | character arrays | categorical arrays  
| cell arrays of strings | tables

Input arrays, specified as numeric arrays, logical arrays, character arrays, categorical arrays, cell arrays of strings, or tables.

A and B must belong to the same class with the following exceptions:

- `logical`, `char`, and all numeric classes can combine with double arrays.
- Cell arrays of strings can combine with `char` arrays.
- Categorical arrays can combine with cell arrays of strings or single strings.

If A and B are both ordinal categorical arrays, they must have the same sets of categories, including their order. If neither A nor B are ordinal, they need not have the same sets of categories, and the comparison is

performed using the category names. In this case, the categories of C are the sorted union of the categories from A and B.

If you specify the 'rows' option, A and B must have the same number of columns.

If A and B are tables, they must have the same variable names. Conversely, the row names do not matter. Two rows that have the same values, but different names, are considered equal.

Furthermore, A and B can be objects with the following class methods:

- sort (or sortrows for the 'rows' option)
- eq
- ne

The object class methods must be consistent with each other. These objects include heterogeneous arrays derived from the same root class.

### setOrder - Order flag

'sorted' (default) | 'stable'

Order flag, specified as 'sorted' or 'stable', indicates the order of the values (or rows) in C.

Order Flag	Meaning
'sorted'	The values (or rows) in C return in sorted order. For example: C = setxor([5 1 3],[4 1 2],'sorted') returns C = [2 3 4 5].
'stable'	The values (or rows) in C return in the same order as in A and B. For example: C = setxor([5 1 3],[4 1 2],'stable') returns C = [5 3 4 2].

## Output Arguments

### **C** - Symmetric difference array

vector | matrix | table

Symmetric difference array, returned as a vector, matrix, or table. If the inputs **A** and **B** are tables, the order of the variables in the resulting table, **C**, is the same as the order of the variables in **A**.

The following describes the shape of **C** when the inputs are vector or matrices and when the 'legacy' flag is not specified:

- If the 'rows' flag is not specified, then **C** is a column vector unless both **A** and **B** are row vectors.
- If the 'rows' flag is not specified and both **A** and **B** are row vectors, then **C** is a row vector.
- If the 'rows' flag is specified, then **C** is a matrix containing the rows of **A** and **B** that are not in the intersection.
- If all the values (or rows) of **A** are also in **B**, then **C** is an empty matrix.

The class of the inputs **A** and **B** determines the class of **C**:

- If the class of **A** and **B** are the same, then **C** is the same class.
- If you combine a `char` or nondouble numeric class with `double`, then **C** is the same class as the nondouble input.
- If you combine a `logical` class with `double`, then **C** is `double`.
- If you combine a cell array of strings with `char`, then **C** is a cell array of strings.
- If you combine a categorical array with a cell array of strings or single string, then **C** is a categorical array.

### **ia** - Index to A

column vector

Index to **A**, returned as a column vector when the 'legacy' flag is not specified. **ia** identifies the values (or rows) in **A** that contribute to the symmetric difference. If there is a repeated value (or row) appearing



exclusively in A, then `ia` contains the index to the first occurrence of the value (or row).

### **ib - Index to B**

column vector

Index to B, returned as a column vector when the 'legacy' flag is not specified. `ib` identifies the values (or rows) in B that contribute to the symmetric difference. If there is a repeated value (or row) appearing exclusively in B, then `ib` contains the index to the first occurrence of the value (or row).

## **Examples**

### **Symmetric Difference of Two Vectors**

Define two vectors with a value in common.

```
A = [5 1 3 3 3]; B = [4 1 2];
```

Find the values of A and B that are not in their intersection.

```
C = setxor(A,B)
```

```
C =
```

```
 2 3 4 5
```

### **Symmetric Difference of Two Tables**

Define two tables with rows in common.

```
A = table([1:5]', ['A'; 'B'; 'C'; 'D'; 'E'], logical([0;1;0;1;0]))
B = table([1:2:10]', ['A'; 'C'; 'E'; 'G'; 'I'], logical(zeros(5,1)))
```

```
A =
```

Var1	Var2	Var3
1	A	false
2	B	true
3	C	false

# setxor

---

```
4 D true
5 E false
```

B =

```
Var1 Var2 Var3
---- ---- -----
1 A false
3 C false
5 E false
7 G false
9 I false
```

Find the rows of A and B that are not in their intersection.

```
C = setxor(A,B)
```

C =

```
Var1 Var2 Var3
---- ---- -----
2 B true
4 D true
7 G false
9 I false
```

## Symmetric Difference of Two Vectors and Indices to Different Values

Define two vectors with a value in common.

```
A = [5 1 3 3 3]; B = [4 1 2];
```

Find the values of A and B that are not in their intersection as well as the index vectors ia and ib.

```
[C,ia,ib] = setxor(A,B)
```

```
C =
 2 3 4 5
```

```
ia =
 3
 1
```

```
ib =
 3
 1
```

C is a sorted combination of the elements A(ia) and B(ib).

### Symmetric Difference of Two Tables and Indices to Different Rows

Define a table, A, of gender, age, and height for five people.

```
A = table(['M';'M';'F'],[27;52;31],[74;68;64],...
'VariableNames',{'Gender' 'Age' 'Height'},...
'RowNames',{'Ted' 'Fred' 'Betty'})
```

```
A =
```

	Gender	Age	Height
	-----	---	-----
Ted	M	27	74
Fred	M	52	68
Betty	F	31	64

Define a table, B, with the same variables as A.

```
B = table(['F';'M'],[64;68],[31;47],...
```

# setxor

---

```
'VariableNames',{ 'Gender' 'Height' 'Age'},...
'RowNames',{ 'Meg' 'Joe'})
```

B =

	Gender	Height	Age
	-----	-----	---
Meg	F	64	31
Joe	M	68	47

Find the rows of A and B that are not in their intersection, as well as the index vectors `ia` and `ib`.

```
[C,ia,ib] = setxor(A,B)
```

C =

	Gender	Age	Height
	-----	---	-----
Ted	M	27	74
Joe	M	47	68
Fred	M	52	68

ia =

```
1
2
```

ib =

```
2
```

C is a sorted combination of the elements `A(ia,:)` and `B(ib,:)`.

## Symmetric Difference of Rows in Two Matrices

Define two matrices with rows in common.

```
A = [7 8 9; 7 7 1; 7 7 1; 1 2 3; 4 5 6];
B = [1 2 3; 4 5 6; 7 7 2];
```

Find the rows of A and B that are not in their intersection as well as the index vectors `ia` and `ib`.

```
[C,ia,ib] = setxor(A,B,'rows')
```

C =

```

 7 7 1
 7 7 2
 7 8 9
```

ia =

```

 2
 1
```

ib =

```

 3
```

C is a sorted combination of the rows of `A(ia,:)` and `B(ib,:)`.

## Symmetric Difference of Two Vectors in Specified Order

Use the `setOrder` argument to specify the ordering of the values in C.

Specify `'stable'` if you want the values in C to have the same order as A and B.

```
A = [5 1 3 3 3]; B = [4 1 2];
```

# setxor

---

```
[C,ia,ib] = setxor(A,B,'stable')
```

```
C =
```

```
 5 3 4 2
```

```
ia =
```

```
 1
 3
```

```
ib =
```

```
 1
 3
```

Alternatively, you can specify 'sorted' order.

```
[C,ia,ib] = setxor(A,B,'sorted')
```

```
C =
```

```
 2 3 4 5
```

```
ia =
```

```
 3
 1
```

```
ib =
```

```
 3
 1
```

### Symmetric Difference of Vectors Containing NaNs

Define two vectors containing NaN.

```
A = [5 NaN NaN]; B = [5 NaN NaN];
```

Find the symmetric difference of vectors A and B.

```
C = setxor(A,B)
```

```
C =
```

```
NaN NaN NaN NaN
```

The `setxor` function treats NaN values as distinct.

### Cell Array of Strings with Trailing White Space

Create a cell array of strings, A.

```
A = {'dog', 'cat', 'fish', 'horse'};
```

Create a cell array of strings, B, where some of the strings have trailing white space.

```
B = {'dog ', 'cat', 'fish ', 'horse'};
```

Find the strings that are not in the intersection of A and B.

```
[C,ia,ib] = setxor(A,B)
```

```
C =
```

```
'dog' 'dog ' 'fish' 'fish '
```

```
ia =
```

```
1
3
```

```
ib =
```

```
 1
 3
```

setxor treats trailing white space in cell arrays of strings as distinct characters.

## **Symmetric Difference of Vectors of Different Classes and Shapes**

Create a column vector character array.

```
A = ['A';'B';'C'], class(A)
```

```
A =
```

```
A
B
C
```

```
ans =
```

```
char
```

Create a row vector containing elements of numeric type double.

```
B = [66 67 68], class(B)
```

```
B =
```

```
 66 67 68
```

```
ans =
```



```
double
```

Find the symmetric difference of A and B.

```
C = setxor(A,B)
```

```
C =
```

```
A
```

```
D
```

The result is a column vector character array.

```
class(C)
```

```
ans =
```

```
char
```

### **Symmetric Difference of Char and Cell Array of Strings**

Create a character array, A.

```
A = ['cat'; 'dog'; 'fox'; 'pig'];
```

```
class(A)
```

```
ans =
```

```
char
```

Create a cell array of strings, B.

```
B={'dog', 'cat', 'fish', 'horse'};
```

```
class(B)
```

```
ans =
```

```
cell
```

Find the strings that are not in the intersection of A and B.

```
C = setxor(A,B)
```

```
C =
```

```
 'fish'
 'fox'
 'horse'
 'pig'
```

The result, C, is a cell array of strings.

```
class(C)
```

```
ans =
```

```
cell
```

## **Preserve Legacy Behavior of setxor**

Use the 'legacy' flag to preserve the behavior of setxor from R2012b and prior releases in your code.

Find the symmetric difference of A and B with the current behavior.

```
A = [5 1 3 3 3]; B = [4 1 2 2];
```

```
[C1,ia1,ib1] = setxor(A,B)
```

```
C1 =
```

```
 2 3 4 5
```

```
ia1 =
```

```
 3
 1
```

```
ib1 =
```

```
 3
 1
```

Find the symmetric difference and preserve the legacy behavior.

```
[C2,ia2,ib2] = setxor(A,B,'legacy')
```

```
C2 =
```

```
 2 3 4 5
```

```
ia2 =
```

```
 5 1
```

```
ib2 =
```

```
 4 1
```

## Tips

- To find the symmetric difference with respect to a subset of variables from a table, you can use column subscripting. For example, you can use `setxor(A(:,vars),B(:,vars))`, where `vars` is a positive integer, a vector of positive integers, a variable name, a cell array of variable names, or a logical vector.

## See Also

`unique` | `intersect` | `ismember` | `issorted` | `setdiff` | `union` | `sort`

## Concepts

- “Combine Categorical Arrays”

# shading

---

**Purpose** Set color shading properties

**Syntax**

```
shading flat
shading faceted
shading interp
shading(axes_handle,...)
```

**Description** The shading function controls the color shading of surface and patch graphics objects.

`shading flat` each mesh line segment and face has a constant color determined by the color value at the endpoint of the segment or the corner of the face that has the smallest index or indices.

`shading faceted` flat shading with superimposed black mesh lines. This is the default shading mode.

`shading interp` varies the color in each line segment and face by interpolating the colormap index or true color value across the line or face.

`shading(axes_handle,...)` applies the shading type to the objects in the axes specified by `axes_handle`, instead of the current axes. Use quoted strings when using a function form. For example:

```
shading(gca, 'interp')
```

## **Examples**      **Display Sphere with Different Types of Shading**

Plot the sphere function and use different types of shading.

```
figure
subplot(2,2,1)
sphere(16)
title('Faceted Shading (Default)')

subplot(2,2,2)
sphere(16)
shading flat
```

```
title('Flat Shading')

subplot(2,2,3)
sphere(16)
shading interp
title('Interpolated Shading')
```

Faceted Shading (Default)

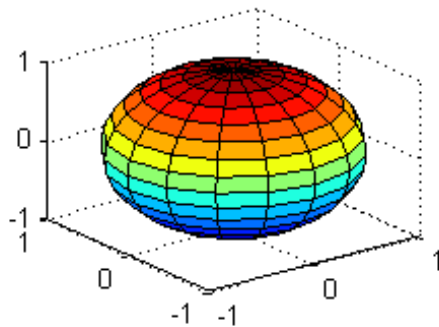

Flat Shading

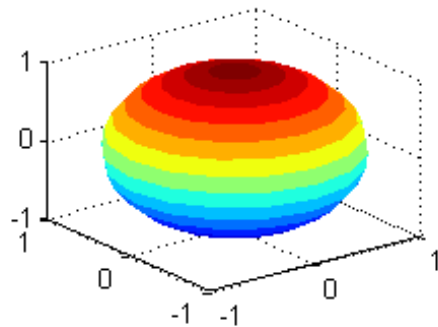

Interpolated Shading

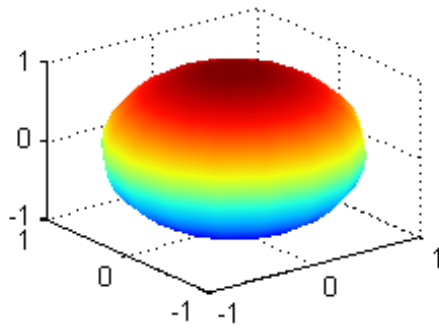

## Algorithms

`shading` sets the `EdgeColor` and `FaceColor` properties of all surface and patch graphics objects in the current axes. `shading interp` sets the

# shading

---

appropriate values, depending on whether the surface or patch objects represent meshes or solid surfaces.

## **See Also**

`fill` | `fill3` | `hidden` | `light` | `lighting` | `mesh` | `patch` | `pcolor`  
| `surf` | `patch` | `surface`

**Purpose** Show most recent graph window

**Syntax** shg

**Description** shg makes the current figure visible and raises it above all other figures on the screen. This is identical to using the command `figure(gcf)`.

**See Also** figure | gca | gcf

# shiftdim

---

**Purpose** Shift dimensions

**Syntax** `B = shiftdim(X,n)`  
`[B,nshifts] = shiftdim(X)`

**Description** `B = shiftdim(X,n)` shifts the dimensions of `X` by `n`. When `n` is positive, `shiftdim` shifts the dimensions to the left and wraps the `n` leading dimensions to the end. When `n` is negative, `shiftdim` shifts the dimensions to the right and pads with singletons.

`[B,nshifts] = shiftdim(X)` returns the array `B` with the same number of elements as `X` but with any leading singleton dimensions removed. A singleton dimension is any dimension for which `size(A,dim) = 1`. `nshifts` is the number of dimensions that are removed.

If `X` is a scalar, `shiftdim` has no effect.

**Examples** The `shiftdim` command is handy for creating functions that, like `sum` or `diff`, work along the first nonsingleton dimension.

```
a = rand(1,1,3,1,2);
[b,n] = shiftdim(a); % b is 3-by-1-by-2 and n is 2.
c = shiftdim(b,-n); % c == a.
d = shiftdim(a,3); % d is 1-by-2-by-1-by-1-by-3.
```

**See Also** `circshift` | `reshape` | `squeeze` | `permute` | `ipermute`



**Purpose** Show or hide figure plot tool

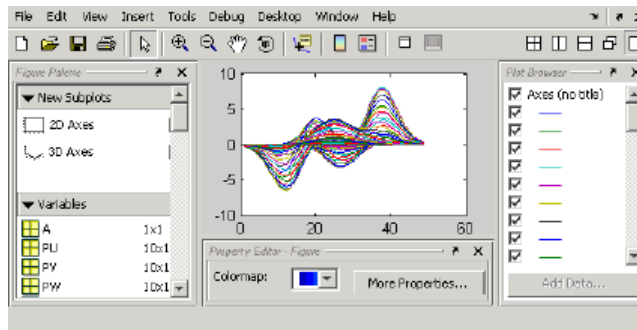

**Syntax**

```
showplottool('tool')
showplottool('on','tool')
showplottool('off','tool')
showplottool('toggle','tool')
showplottool(figure_handle,...)
```

**Description** `showplottool('tool')` shows the specified plot tool on the current figure. `tool` can be one of the following strings:

- `figurepalette`
- `plotbrowser`
- `propertyeditor`

`showplottool('on','tool')` shows the specified plot tool on the current figure.

`showplottool('off','tool')` hides the specified plot tool on the current figure.

`showplottool('toggle','tool')` toggles the visibility of the specified plot tool on the current figure.

`showplottool(figure_handle,...)` operates on the specified figure instead of the current figure.

# showplottool



---

---

**Note** When you dock, undock, resize, or reposition a plotting tool and then close it, it will still be configured as you left it the next time you open it. There is no command to reset plotting tools to their original, default locations.

---

## Alternatives

Click the larger Plotting Tools icon  on the figure toolbar to collectively enable plotting tools, and the smaller icon  to collectively disable them. Individually select the **Figure Palette**, **Plot Browser**, and **Property Editor** tools from the figure's **View** menu. For details, see “Customize Graph Using Plot Tools”.

## See Also

`figurepalette` | `plotbrowser` | `plottools` | `propertyeditor`

## Purpose

Reduce size of patch faces

## Syntax

```
shrinkfaces(p,sf)
nfv = shrinkfaces(p,sf)
nfv = shrinkfaces(fv,sf)
shrinkfaces(p)
nfv = shrinkfaces(f,v,sf)
[nf,nv] = shrinkfaces(...)
```

## Description

`shrinkfaces(p,sf)` shrinks the area of the faces in patch `p` to shrink factor `sf`. A shrink factor of 0.6 shrinks each face to 60% of its original area. If the patch contains shared vertices, the MATLAB software creates nonshared vertices before performing the face-area reduction.

`nfv = shrinkfaces(p,sf)` returns the face and vertex data in the struct `nfv`, but does not set the `Faces` and `Vertices` properties of patch `p`.

`nfv = shrinkfaces(fv,sf)` uses the face and vertex data from the struct `fv`.

`shrinkfaces(p)` and `shrinkfaces(fv)` (without specifying a shrink factor) assume a shrink factor of 0.3.

`nfv = shrinkfaces(f,v,sf)` uses the face and vertex data from the arrays `f` and `v`.

`[nf,nv] = shrinkfaces(...)` returns the face and vertex data in two separate arrays instead of a struct.

## Examples

This example uses the flow data set, which represents the speed profile of a submerged jet within an infinite tank (type `help flow` for more information). Two isosurfaces provide a before and after view of the effects of shrinking the face size.

- First `reducevolume` samples the flow data at every other point and then `isosurface` generates the faces and vertices data.
- The `patch` command accepts the face/vertex struct and draws the first (`p1`) isosurface.

# shrinkfaces

---

- Use the `daspect`, `view`, and `axis` commands to set up the view and then add a title.
- The `shrinkfaces` command modifies the face/vertex data and passes it directly to `patch`.

```
[x,y,z,v] = flow;
[x,y,z,v] = reducevolume(x,y,z,v,2);
fv = isosurface(x,y,z,v,-3);
p1 = patch(fv);
set(p1,'FaceColor','red','EdgeColor',[.5,.5,.5]);
daspect([1 1 1]); view(3); axis tight
title('Original')
```

```
figure
p2 = patch(shrinkfaces(fv,.3));
set(p2,'FaceColor','red','EdgeColor',[.5,.5,.5]);
daspect([1 1 1]); view(3); axis tight
title('After Shrinking')
```

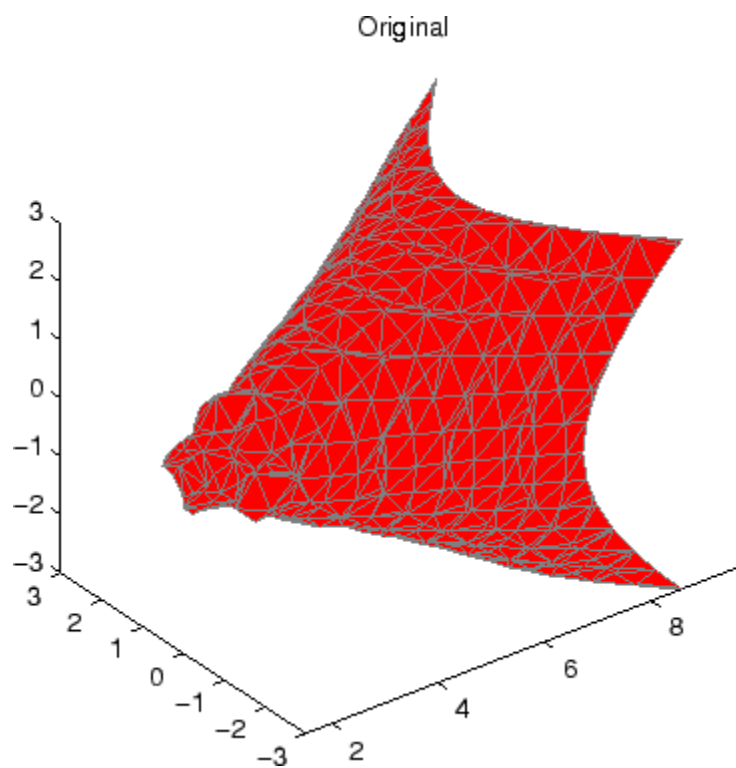

# shrinkfaces

---

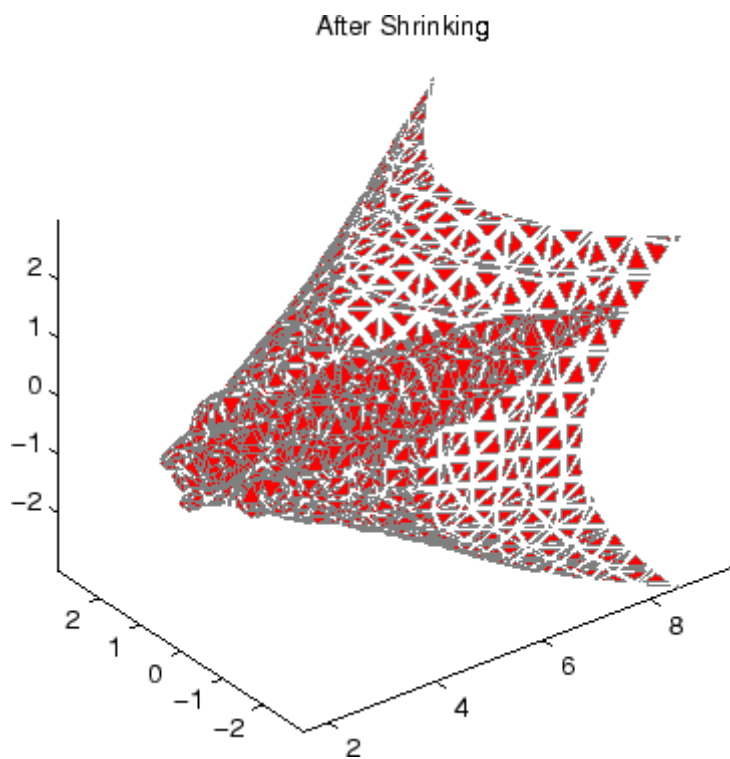

## See Also

[isosurface](#) | [patch](#) | [reducevolume](#) | [daspect](#) | [view](#) | [axis](#)

**Purpose** Signum function

**Syntax** `Y = sign(X)`

**Description** `Y = sign(X)` returns an array `Y` the same size as `X`, where each element of `Y` is:

- 1 if the corresponding element of `X` is greater than zero
- 0 if the corresponding element of `X` equals zero
- -1 if the corresponding element of `X` is less than zero

For nonzero complex `X`, `sign(X) = X./abs(X)`.

**See Also** `abs` | `conj` | `imag` | `real`

# sin

---

**Purpose** Sine of argument in radians

**Syntax** `Y = sin(X)`

**Description** `Y = sin(X)` returns the sine of the elements of `X`. The `sin` function operates element-wise on arrays. The function accepts both real and complex inputs. For real values of `X` in the interval `[-Inf, Inf]`, `sin` returns real values in the interval `[-1, 1]`. For complex values of `X`, `sin` returns complex values. All angles are in radians.

**Input Arguments** **X - Input angle in radians**  
scalar value | vector | matrix | N-D array

Input angle in radians, specified as a real-valued or complex-valued scalar, vector, matrix or N-D array. The `sin` operation is element-wise when `X` is non-scalar.

**Data Types**

single | double

**Complex Number Support:** Yes

**Output Arguments** **Y - Sine of input angle**  
scalar value | vector | matrix | N-D array

Sine of input angle, returned as a real-valued or complex-valued scalar, vector, matrix or N-D array.

**Examples** **Plot Sine Function**

Plot the sine function over the domain  $-\pi \leq x \leq \pi$ .

```
x = -pi:0.01:pi;
plot(x,sin(x)), grid on
```



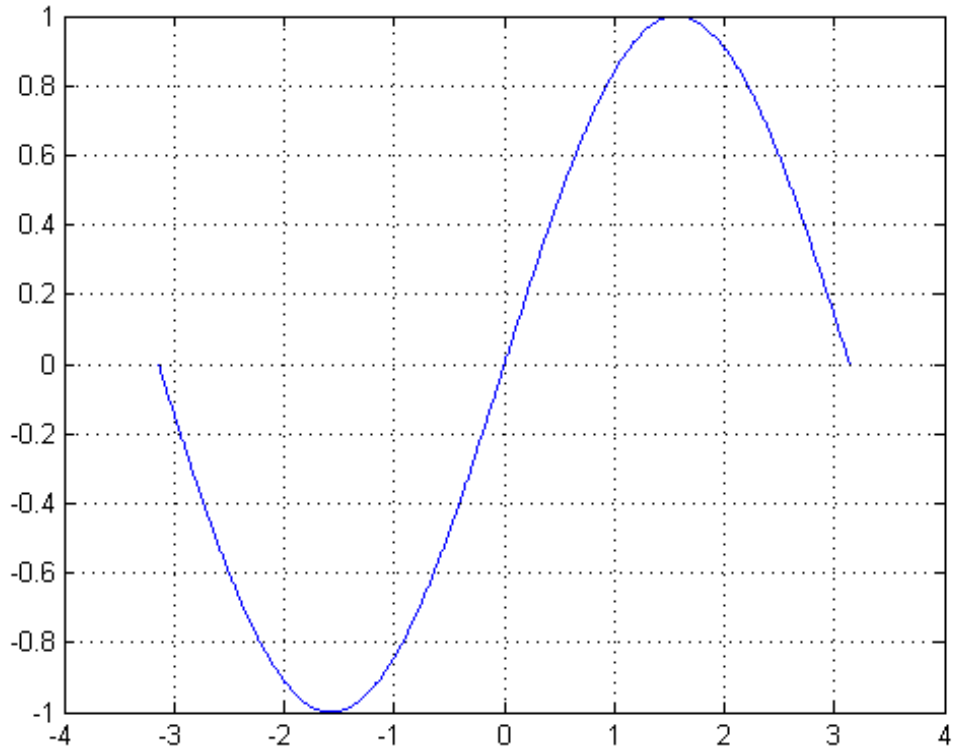

### Sine of Vector of Complex Angles

Calculate the sine of the complex angles in vector x.

```
x = [-i pi+i*pi/2 -1+i*4];
y = sin(x)
```

y =

# sin

---

0.0000 - 1.1752i    0.0000 - 2.3013i    -22.9791 +14.7448i

## Definitions

### Sine Function

The sine of an angle,  $\alpha$ , defined with reference to a right angled triangle is

$$\text{sine}(\alpha) = \frac{\text{opposite side}}{\text{hypotenuse}} = \frac{a}{h}.$$

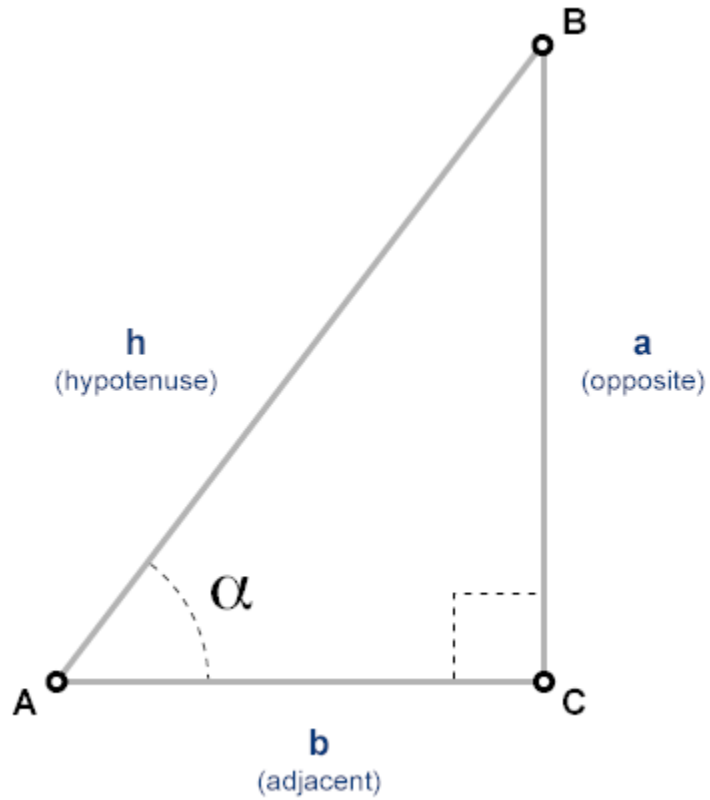

The sine of a complex angle,  $\alpha$ , is

$$\text{sine}(\alpha) = \frac{e^{i\alpha} - e^{-i\alpha}}{2i}.$$

**See Also**

sind | asin | asind | sinh

# sind

---

<b>Purpose</b>	Sine of argument in degrees
<b>Syntax</b>	$Y = \text{sind}(X)$
<b>Description</b>	$Y = \text{sind}(X)$ returns the sine of the elements in $X$ , which are expressed in degrees.
<b>Input Arguments</b>	<b>X - Angle in degrees</b> scalar value   vector   matrix   N-D array  Angle in degrees, specified as a real-valued or complex-valued scalar, vector, matrix, or N-D array. The <code>sind</code> operation is element-wise when $X$ is nonscalar.  <b>Data Types</b> single   double <b>Complex Number Support:</b> Yes
<b>Output Arguments</b>	<b>Y - Sine of angle</b> scalar value   vector   matrix   N-D array  Sine of angle, returned as a real-valued or complex-valued scalar, vector, matrix, or N-D array of the same size as $X$ .
<b>Examples</b>	<b>Sine of 180 degrees compared to sine of radians</b>  <code>sind(180)</code>  <code>ans =</code>  0  <code>sin(pi)</code>  <code>ans =</code>  1.2246e-16

**Sine of vector of complex angles, specified in degrees**

```
z = [90+i 15+2i 10+3i];
y = sind(z)
```

```
y =
```

```
1.0002 0.2590 + 0.0337i 0.1739 + 0.0516i
```

**See Also**

[sin](#) | [asind](#) | [asin](#)

# single

---

**Purpose** Convert to single precision

**Syntax** `B = single(A)`

**Description** `B = single(A)` converts the matrix `A` to single precision, returning that value in `B`. `A` can be any numeric object (such as a `double`). If `A` is already single precision, `single` has no effect. Single-precision quantities require less storage than double-precision quantities, but have less precision and a smaller range.

The `single` class is primarily meant to be used to store single-precision values. Hence most operations that manipulate arrays without changing their elements are defined. Examples are `reshape`, `size`, the relational operators, subscripted assignment, and subscripted reference.

You can define your own methods for the `single` class by placing the appropriately named method in an `@single` folder within a folder on your path.

## Examples

```
a = magic(4);
b = single(a);
```

```
whos
```

Name	Size	Bytes	Class
a	4x4	128	double array
b	4x4	64	single array

**See Also** `double`

**Purpose** Hyperbolic sine of argument in radians

**Syntax**  $Y = \sinh(X)$

**Description** The `sinh` function operates element-wise on arrays. The function's domains and ranges include complex values. All angles are in radians.  $Y = \sinh(X)$  returns the hyperbolic sine of the elements of  $X$ .

**Examples** **Graph of Hyperbolic Sine Function**

Graph the hyperbolic sine over the domain  $-5 \leq x \leq 5$ .

```
x = -5:0.01:5;
plot(x,sinh(x)), grid on
```

# sinh

---

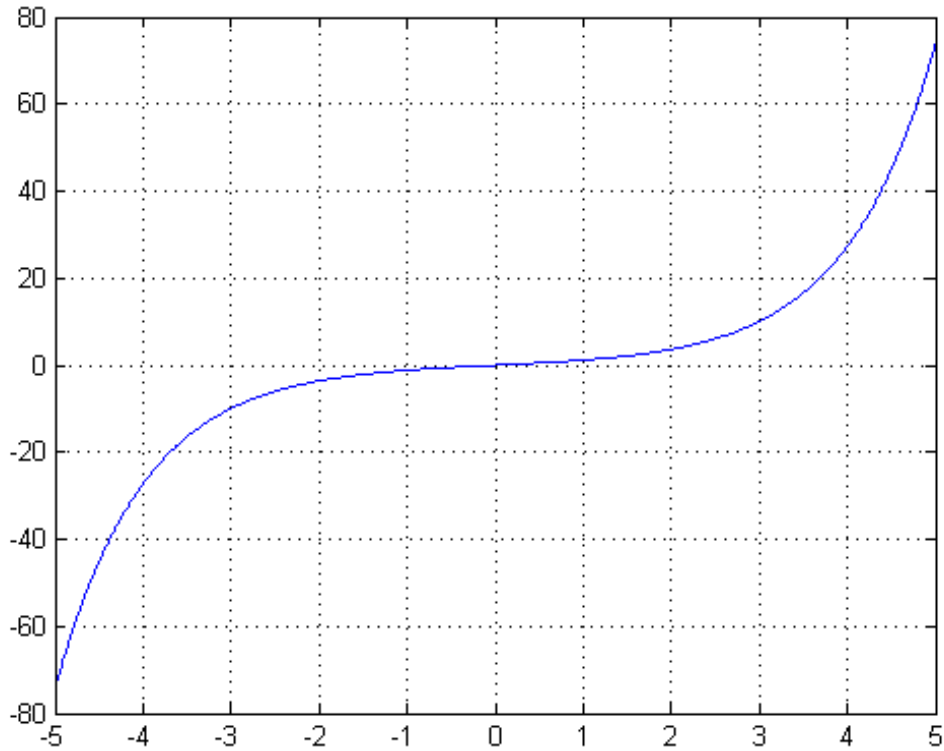

## Definitions      Hyperbolic Sine

The hyperbolic sine of  $z$  is

$$\sinh(z) = \frac{e^z - e^{-z}}{2}.$$

## See Also      [sin](#) | [asinh](#) | [cosh](#)



**Purpose**

Array dimensions

**Syntax**

```
d = size(X)
[m,n] = size(X)
m = size(X,dim)
[d1,d2,d3,...,dn] = size(X),
```

**Description**

`d = size(X)` returns the sizes of each dimension of array `X` in a vector, `d`, with `ndims(X)` elements.

- If `X` is a scalar, then `size(X)` returns the vector `[1 1]`. Scalars are regarded as a 1-by-1 arrays in MATLAB.
- If `X` is a table, `size(X)` returns a two-element row vector consisting of the number of rows and the number of variables in the table. Variables in the table can have multiple columns, but `size` only counts the variables and rows.

`[m,n] = size(X)` returns the size of matrix `X` in separate variables `m` and `n`.

`m = size(X,dim)` returns the size of the dimension of `X` specified by scalar `dim`.

`[d1,d2,d3,...,dn] = size(X)`, for `n > 1`, returns the sizes of the dimensions of the array `X` in the variables `d1,d2,d3,...,dn`, provided the number of output arguments `n` equals `ndims(X)`. If `n` does not equal `ndims(X)`, the following exceptions hold:

- |                              |                                                                                                                                                                                                                                                                               |
|------------------------------|-------------------------------------------------------------------------------------------------------------------------------------------------------------------------------------------------------------------------------------------------------------------------------|
| <code>n &lt; ndims(X)</code> | <code>di</code> equals the size of the <code>i</code> th dimension of <code>X</code> for $0 < i < n$ , but <code>dn</code> equals the product of the sizes of the remaining dimensions of <code>X</code> , that is, dimensions <code>n</code> through <code>ndims(X)</code> . |
| <code>n &gt; ndims(X)</code> | <code>size</code> returns ones in the “extra” variables, that is, those corresponding to <code>ndims(X)+1</code> through <code>n</code> .                                                                                                                                     |

# size

---

---

**Note** For a Java array, `size` returns the length of the Java array as the number of rows. The number of columns is always 1. For a Java array of arrays, the result describes only the top level array.

---

## Examples

### Size of Dimensions in 3-D Array

Find the size of `rand(2,3,4)`.

```
d = size(rand(2,3,4))
```

```
d =
```

```
 2 3 4
```

The size is output as a single vector.

Find the size of the second dimension of `rand(2,3,4)`.

```
m = size(rand(2,3,4),2)
```

```
m =
```

```
 3
```

The size is output as a scalar.

Assign the size of each dimension to a separate variable.

```
[m,n,p] = size(rand(2,3,4))
```

```
m =
```

```
 2
```

```
n =
```

3

p =

4

**Size of Table**

Create a table with four variables listing patient information for five people.

```
LastName = {'Smith';'Johnson';'Williams';'Jones';'Brown'};
Age = [38;43;38;40;49];
Height = [71;69;64;67;64];
Weight = [176;163;131;133;119];
BloodPressure = [124 93; 109 77; 125 83; 117 75; 122 80];
```

```
X = table(Age,Height,Weight,BloodPressure,'RowNames',LastName)
```

X =

	Age	Height	Weight	BloodPressure	
	---	-----	-----	-----	-----
Smith	38	71	176	124	93
Johnson	43	69	163	109	77
Williams	38	64	131	125	83
Jones	40	67	133	117	75
Brown	49	64	119	122	80

Find the size of the table.

```
d = size(X)
```

d =

5 4

# size

---

`size` counts four variables, even though the variable `BloodPressure` contains two columns.

## **Specify Different Number of Outputs than `ndims(X)`**

Assign the size of each dimension to a separate variable where the number of outputs matches the number of dimensions.

```
X = ones(3,4,5);
[d1,d2,d3] = size(X)
```

```
d1 =
```

```
3
```

```
d2 =
```

```
4
```

```
d3 =
```

```
5
```

There is one output for each dimension of `X`.

Specify fewer output variables than `ndims(X)`.

```
[d1,d2] = size(X)
```

```
d1 =
```

```
3
```

```
d2 =
```

```
20
```

The “extra” dimensions are collapsed into a single product.

Specify more output variables than `ndims(X)`.

```
[d1,d2,d3,d4,d5,d6] = size(X)
```

```
d1 =
```

```
 3
```

```
d2 =
```

```
 4
```

```
d3 =
```

```
 5
```

```
d4 =
```

```
 1
```

```
d5 =
```

```
 1
```

```
d6 =
```

```
 1
```

The “extra” variables all represent singleton dimensions.

# size

---

## See Also

`exist` | `length` | `ndims` | `numel` | `whos`

## Purpose

Size of containers.Map object

## Syntax

```
dim = size(mapObj,1)
dimVector = size(mapObj)
[dim1,dim2,...,dimN] = size(mapObj)
```

## Description

`dim = size(mapObj,1)` returns a scalar numeric value that indicates the number of key-value pairs in `mapObj`. If you call `size` with a numeric second input argument other than 1, the `size` method returns the scalar numeric value 1.

`dimVector = size(mapObj)` returns a two-element vector `[k,1]`, where `k` is the number of key-value pairs in `mapObj`.

`[dim1,dim2,...,dimN] = size(mapObj)` returns `[k,1,...,1]`.

## Input Arguments

### mapObj

Object of class `containers.Map`.

## Output Arguments

### dim

Scalar numeric value that indicates the number of key-value pairs in `mapObj`.

### dimVector

Two-element numeric vector `[k,1]`, where `k` is the number of key-value pairs in `mapObj`.

### [dim1,dim2,...,dimN]

Numeric scalar values. Variable `dim1` equals `k`, where `k` is the number of key-value pairs in `mapObj`. All other outputs equal 1.

## Examples

### Determine the Size of a Map

Construct a map and find the number of key-value pairs:

```
myKeys = {'a','b','c'};
myValues = [1,2,3];
```

## containers.Map.size

---

```
mapObj = containers.Map(myKeys,myValues);
dim = size(mapObj,1)
```

This code returns a scalar numeric value:

```
dim =
 3
```

If you do not specify a second input argument,

```
dimVector = size(mapObj)
```

then the `size` method returns a vector:

```
dimVector =
 3 1
```

### See Also

[containers.Map](#) | [isKey](#) | [keys](#) | [length](#) | [values](#)



<b>Purpose</b>	Array dimensions
<b>Syntax</b>	<pre>allDims = size(matObj,variable) [dim1,...,dimN] = size(matObj,variable) selectedDim = size(matObj,variable,dim)</pre>
<b>Description</b>	<p><code>allDims = size(matObj,variable)</code> returns the size of each dimension of the specified variable in the file corresponding to <code>matObj</code>. Output <code>allDims</code> is a 1-by-<code>m</code> vector, where <code>m = ndims(variable)</code>.</p> <p><code>[dim1,...,dimN] = size(matObj,variable)</code> returns the sizes of each dimension in separate output variables <code>dim1,...,dimN</code>.</p> <p><code>selectedDim = size(matObj,variable,dim)</code> returns the size of the specified dimension.</p>
<b>Tips</b>	<ul style="list-style-type: none"><li>• Do not call <code>size</code> with the syntax <code>size(matObj.variable)</code>. This syntax loads the entire contents of the variable into memory. For very large variables, this load operation results in Out of Memory errors.</li></ul>
<b>Input Arguments</b>	<p><b>matObj</b> Object created by the <code>matfile</code> function.</p> <p><b>variable</b> String enclosed in single quotation marks that specifies the name of a variable in the MAT-file corresponding to <code>matObj</code>.</p> <p><b>dim</b> Nonzero positive scalar integer that specifies a dimension of the variable.</p>
<b>Output Arguments</b>	<p><b>allDims</b> 1-by-<code>m</code> vector of sizes of the dimensions of the specified variable, where <code>m = ndims(variable)</code>.</p> <p><b>dim1,...,dimN</b></p>

Scalar numeric values, where `dimK` contains the size of the `K`th dimension of variable:

- If `N < ndims(variable)`, then `dimN`, equals the product of the sizes of dimensions `N` through `ndims(variable)`.
- If `N > ndims(variable)`, the `size` method returns ones in the output variables corresponding to dimensions `ndims(variable)+1` through `N`.

## **selectedDim**

Scalar numeric value that contains the size of the selected dimension for the specified variable.

## **Examples**

Find the size of the matrix `topo` in `topography.mat` without loading any data:

```
matObj = matfile('topography.mat');
[nrows,ncols] = size(matObj,'topo');
```

---

Determine the dimensions of a variable, and process one part of the variable at a time. In this case, calculate and store the average of each column of variable `stocks` in the example file `stocks.mat`:

```
filename = 'stocks.mat';
matObj = matfile(filename);
[nrows,ncols] = size(matObj,'stocks');

avgs = zeros(1,ncols);
for idx = 1:ncols
 avgs(idx) = mean(matObj.stocks(:,idx));
end
```

---

Create a three-dimensional array, and call the `size` method with different numbers of output arguments:

```
matObj = matfile('temp.mat','Writable',true);
matObj.X = rand(2,3,4);

d = size(matObj,'X')
d2 = size(matObj,'X',2)
[m,n] = size(matObj,'X')
[m1,m2,m3,m4] = size(matObj,'X')
```

This code returns

```
d =
 2 3 4

d2 =
 3

m =
 2
n =
 12

m1 =
 2
m2 =
 3
m3 =
 4
m4 =
 1
```

## See Also

[matfile](#) | [whos](#)

# size (serial)

---

**Purpose** Size of serial port object array

**Syntax**

```
d = size(obj)
[m,n] = size(obj)
[m1,m2,m3,...,mn] = size(obj)
m = size(obj,dim)
```

**Description**

`d = size(obj)` returns the two-element row vector `d` containing the number of rows and columns in the serial port object, `obj`.

`[m,n] = size(obj)` returns the number of rows, `m` and columns, `n` in separate output variables.

`[m1,m2,m3,...,mn] = size(obj)` returns the length of the first `n` dimensions of `obj`.

`m = size(obj,dim)` returns the length of the dimension specified by the scalar `dim`. For example, `size(obj,1)` returns the number of rows.

**See Also** `length`

**Purpose** (Will be removed) Size of triangulation matrix

---

**Note** `size(TriRep)` will be removed in a future release. Use `size(triangulation)` instead.

---

`TriRep` will be removed in a future release. Use `triangulation` instead.

---

**Syntax** `size(TR)`

**Description** `size(TR)` provides size information for a triangulation matrix. The matrix is of size `mtri-by-nv`, where `mtri` is the number of simplices and `nv` is the number of vertices per simplex (triangle/tetrahedron, etc).

**Input Arguments**

<code>TR</code>	Triangulation matrix
-----------------	----------------------

**Definitions** A simplex is a triangle/tetrahedron or higher-dimensional equivalent.

**See Also** `size` | `deLaunayTriangulation` | `triangulation`

## size (tscollection)

---

<b>Purpose</b>	Size of tscollection object
<b>Syntax</b>	<code>size(tsc)</code>
<b>Description</b>	<code>size(tsc)</code> returns <code>[n m]</code> , where <code>n</code> is the length of the time vector and <code>m</code> is the number of tscollection members.
<b>See Also</b>	<code>length (tscollection)</code>   <code>isempty (tscollection)</code>   <code>tscollection</code>

**Purpose**

Volumetric slice plot

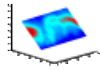
**Syntax**

```
slice(V, sx, sy, sz)
slice(X, Y, Z, V, sx, sy, sz)
slice(V, XI, YI, ZI)
slice(X, Y, Z, V, XI, YI, ZI)
slice(..., 'method')
slice(axes_handle, ...)
h = slice(...)
```

**Description**

`slice` displays orthogonal slice planes through volumetric data.

`slice(V, sx, sy, sz)` draws slices along the  $x$ ,  $y$ ,  $z$  directions in the volume  $V$  at the points in the vectors `sx`, `sy`, and `sz`.  $V$  is an  $m$ -by- $n$ -by- $p$  volume array containing data values at the default location  $X = 1:n$ ,  $Y = 1:m$ ,  $Z = 1:p$ . Each element in the vectors `sx`, `sy`, and `sz` defines a slice plane in the  $x$ -,  $y$ -, or  $z$ -axis direction.

`slice(X, Y, Z, V, sx, sy, sz)` draws slices of the volume  $V$ .  $X$ ,  $Y$ , and  $Z$  are three-dimensional arrays specifying the coordinates for  $V$ .  $X$ ,  $Y$ , and  $Z$  must be monotonic and orthogonally spaced (as if produced by the function `meshgrid`). The color at each point is determined by 3-D interpolation into the volume  $V$ .

`slice(V, XI, YI, ZI)` draws data in the volume  $V$  for the slices defined by  $XI$ ,  $YI$ , and  $ZI$ .  $XI$ ,  $YI$ , and  $ZI$  are matrices that define a surface, and the volume is evaluated at the surface points.  $XI$ ,  $YI$ , and  $ZI$  must all be the same size.

`slice(X, Y, Z, V, XI, YI, ZI)` draws slices through the volume  $V$  along the surface defined by the arrays  $XI$ ,  $YI$ ,  $ZI$ .

`slice(..., 'method')` specifies the interpolation method. `'method'` is `'linear'`, `'cubic'`, or `'nearest'`.

- `linear` specifies trilinear interpolation (the default).

# slice

---

- `cubic` specifies tricubic interpolation.
- `nearest` specifies nearest-neighbor interpolation.

`slice(axes_handle,...)` plots into the axes with the handle `axes_handle` instead of into the current axes object (`gca`). The axes `clim` property is set to span the finite values of `V`.

`h = slice(...)` returns a vector of handles to surface graphics objects.

## Tips

The color drawn at each point is determined by interpolation into the volume `V`.

## Examples

Visualize the function

$$v = xe^{(-x^2-y^2-z^2)}$$

over the range  $-2 \leq x \leq 2$ ,  $-2 \leq y \leq 2$ ,  $-2 \leq z \leq 2$ :

```
[x,y,z] = meshgrid(-2:.2:2,-2:.25:2,-2:.16:2);
v = x.*exp(-x.^2-y.^2-z.^2);
xslice = [-1.2,.8,2]; yslice = 2; zslice = [-2,0];
slice(x,y,z,v,xslice,yslice,zslice)
colormap hsv
```



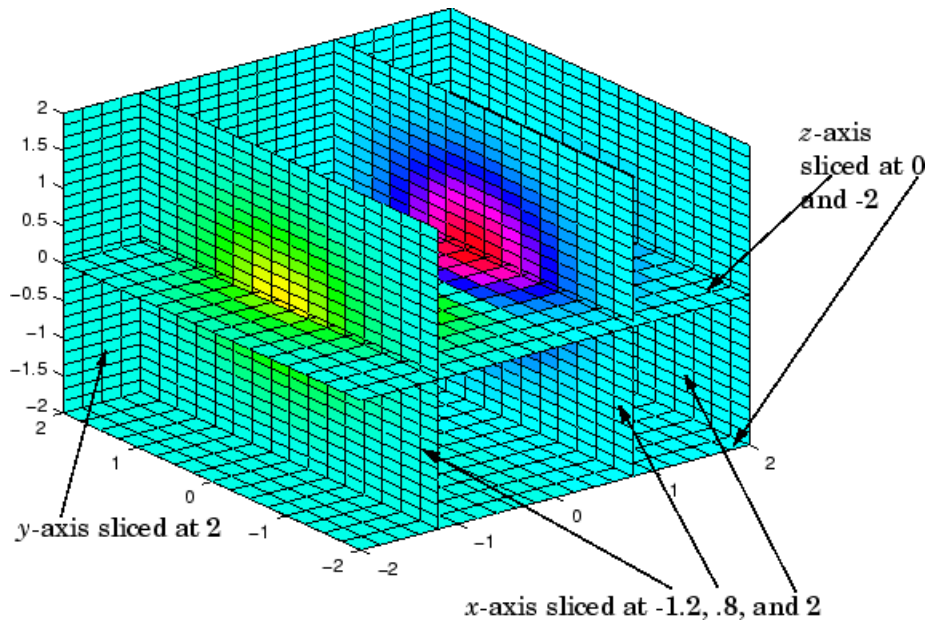

### Slicing At Arbitrary Angles

You can also create slices that are oriented in arbitrary planes. To do this,

- Create a slice surface in the domain of the volume (`surf`, `linspace`).
- Orient this surface with respect to the axes (`rotate`).
- Get the `XData`, `YData`, and `ZData` of the surface (`get`).
- Use this data to draw the slice plane within the volume.

For example, these statements slice the volume in the first example with a rotated plane. Placing these commands within a `for` loop “passes” the plane through the volume along the  $z$ -axis.

```
for i = -2:.5:2
 hsp = surf(linspace(-2,2,20),linspace(-2,2,20),...
 zeros(20)+i);
```

# slice

---

```
rotate(hsp,[1,-1,1],30)
xd = get(hsp,'XData');
yd = get(hsp,'YData');
zd = get(hsp,'ZData');
delete(hsp)
slice(x,y,z,v,[-2,2],2,-2) % Draw some volume boundaries
hold on
slice(x,y,z,v,xd,yd,zd)
hold off
axis tight
view(-5,10)
drawnow
end
```

The following picture illustrates three positions of the same slice surface as it passes through the volume.

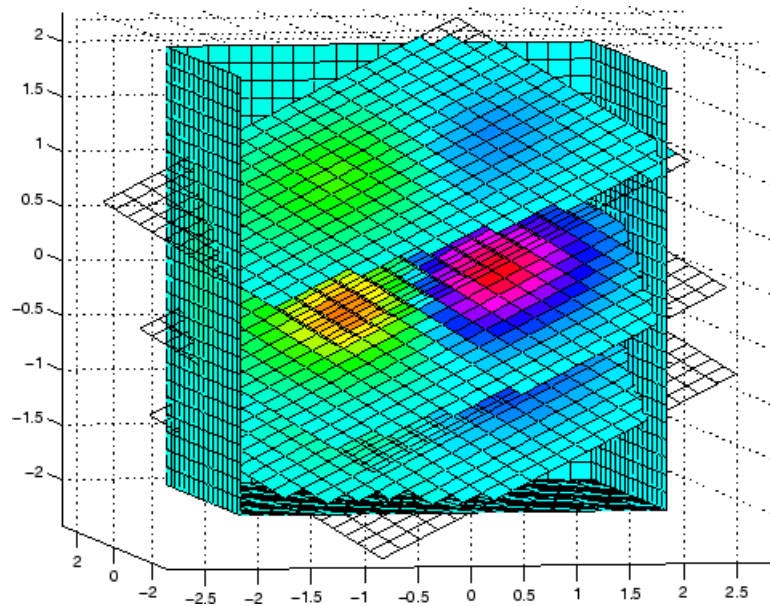

## Slicing with a Nonplanar Surface

You can slice the volume with any surface. This example probes the volume created in the previous example by passing a spherical slice surface through the volume.

```
[xsp,ysp,zsp] = sphere;
% Draw some volume boundaries
% Draw some volume boundaries
slice(x,y,z,v,[-2,2],2,-2)
for i = -3:.2:3
 hsp = surface(xsp+i,ysp,zsp);
 rotate(hsp,[1 0 0],90)
 xd = get(hsp,'XData');
 yd = get(hsp,'YData');
 zd = get(hsp,'ZData');
 delete(hsp)
 hold on
 hslicer = slice(x,y,z,v,xd,yd,zd);
 axis tight
 xlim([-3,3])
 view(-10,35)
 drawnow
 delete(hslicer)
 hold off
end
```

The following picture illustrates three positions of the spherical slice surface as it passes through the volume.

# slice

---

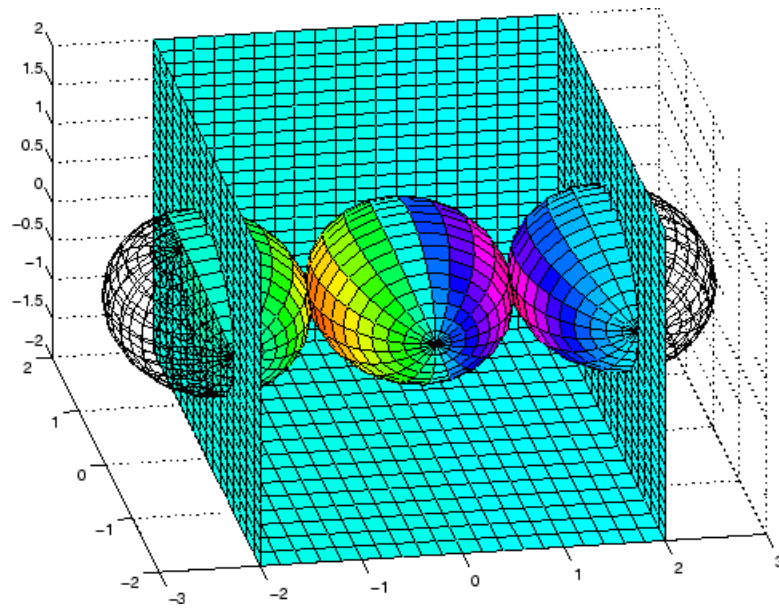

## See Also

`interp3` | `meshgrid`

## How To

- Exploring Volumes with Slice Planes

**Purpose**

Smooth 3-D data

**Syntax****Description**

`W = smooth3(V)` smooths the input data `V` and returns the smoothed data in `W`.

`W = smooth3(V, 'filter')` *filter* determines the convolution kernel and can be the strings

- 'gaussian'
- 'box' (default)

`W = smooth3(V, 'filter', size)` sets the size of the convolution kernel (default is [3 3 3]). If `size` is scalar, then `size` is interpreted as [size, size, size].

`W = smooth3(V, 'filter', size, sd)` sets an attribute of the convolution kernel. When *filter* is gaussian, `sd` is the standard deviation (default is .65).

**Examples**

This example smooths some random 3-D data and then creates an isosurface with end caps.

```
rng(9, 'twister')
data = rand(10,10,10);
data = smooth3(data, 'box', 5);
patch(isocaps(data, .5), ...
 'FaceColor', 'interp', 'EdgeColor', 'none');
p1 = patch(isosurface(data, .5), ...
 'FaceColor', 'blue', 'EdgeColor', 'none');
isonormals(data, p1)
view(3);
axis vis3d tight
camlight left;
lighting phong
```

# smooth3

---

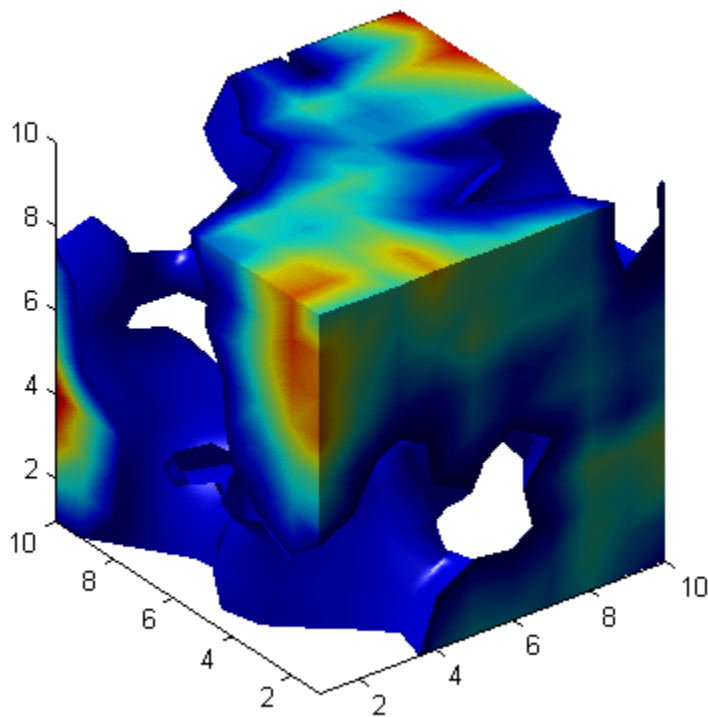

## See Also

[isocaps](#) | [isonormals](#) | [isosurface](#) | [patch](#)

## How To

- [Displaying an Isosurface](#)

<b>Purpose</b>	Force snapshot of image for inclusion in published document
<b>Syntax</b>	snapnow
<b>Description</b>	The snapnow command forces a snapshot of the image or plot that the code has most recently generated for presentation in a published document. The output appears in the published document at the end of the cell that contains the snapnow command. When used outside the context of publishing a file, snapnow has the same behavior as drawnow. That is, if you run a file that contains the snapnow command, the MATLAB software interprets it as though it were a drawnow command.
<b>Examples</b>	<p>This example demonstrates the difference between publishing code that contains the snapnow command and running that code. The first image shows the results of publishing the code and the second image shows the results of running the code.</p> <p>Suppose you have a file that contains the following code:</p> <pre>%% Scale magic Data and %% Display as Image:  for i=1:3     imagesc(magic(i))     snapnow end</pre> <p>When you publish the code to HTML, the published document contains a title, a table of contents, the commented text, the code, and each of the three images produced by the for loop. (In the published document shown, the size of the images have been reduced.)</p>

## Scale magic Data and

### Contents

- [Display as Image:](#)

### Display as Image:

```
for i=1:3
 imagesc(magic(i))
 snapnow
end
```



When you run the code, a single Figure window opens and MATLAB updates the image within this window as it evaluates each iteration of the for loop. Each successive image replaces the one that preceded it, so that the Figure window appears as follows when the code evaluation completes.



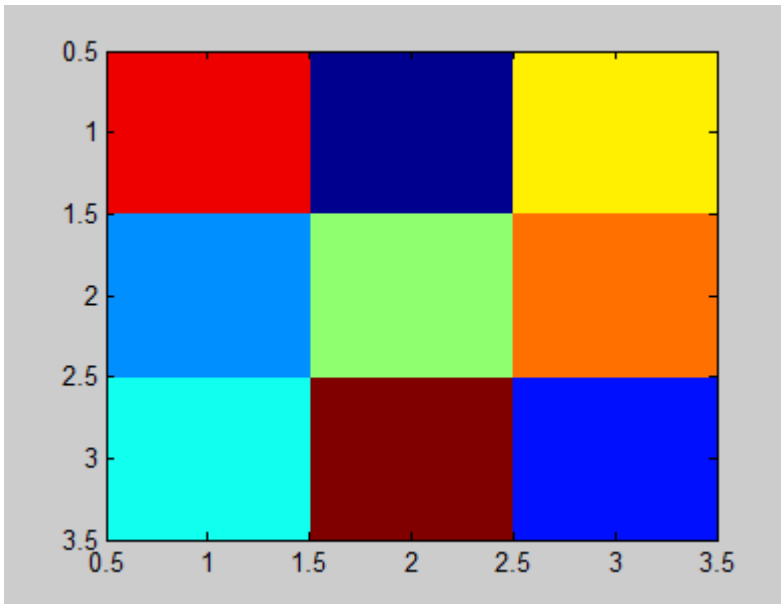

**See Also**

`drawnow`

**Concepts**

- “Image Snapshot”

# sort

---

**Purpose** Sort array elements

**Syntax**

```
B = sort(A)
B = sort(A,dim)
B = sort(__ ,mode)
[B,I] = sort(__)
```

**Description** `B = sort(A)` sorts the elements of `A` in ascending order along the first array dimension whose size does not equal 1. For strings, this is a sort in ASCII dictionary order. The sort is case-sensitive; uppercase letters appear in the output before lowercase.

- If `A` is a vector, then `sort(A)` sorts the vector elements.
- If `A` is a nonempty, nonvector matrix, then `sort(A)` treats the columns of `A` as vectors and sorts each column.
- If `A` is an empty 0-by-0 matrix, then `sort(A)` returns an empty 0-by-0 matrix.
- If `A` is a multidimensional array, then `sort(A)` treats as vectors all values along the first array dimension whose size does not equal 1, and then sorts each vector.

`B = sort(A,dim)` sorts the elements of `A` along dimension `dim`. For example, if `A` is a matrix, then `sort(A,2)` sorts the elements in each row.

`B = sort( __ ,mode)` sorts in the order specified by `mode` using any of the above syntaxes. The single string, 'ascend', indicates ascending order (default) and 'descend' indicates descending order.

`[B,I] = sort( __ )` also returns a collection of index vectors in an array, `I`, using any of the above syntaxes. `I` is the same size as `A` and describes the rearrangement of the elements along the sorted dimension. In general, if `B` is an array with  $N$  dimensions whose sizes do not equal 1, then  $N-1$  loops are required to use the indexing array, `I`.

This requirement is because `I` contains only location information for the single dimension being sorted. For example,

- If you sort a numeric vector or cell array of strings, then  $B = A(I)$ .
- If you sort the columns of a matrix, then the above relation holds for each column independently. That is, each column of `I` is a permutation vector of the corresponding column of `A` such that

```
for j = 1:size(A,2)
 B(:,j) = A(I(:,j),j);
end
```

## Input Arguments

### A - Input array

vector | matrix | multidimensional array

Input array, specified as a vector, matrix, or multidimensional array. The data type of `A` can be numeric, `logical`, `char`, `cell`, or categorical. If `A` contains NaN values or undefined categorical elements, `sort(A)` places them on the high end of the sort (as if they are large numbers).

If `A` is complex, the `sort` function sorts the elements by magnitude. If magnitudes are equal, the `sort` function also sorts by phase angle on the interval  $[-\pi, \pi]$ .

**Complex Number Support:** Yes

### dim - Dimension to operate along

positive integer scalar

Dimension to operate along, specified as a positive integer scalar. If no value is specified, the default is the first array dimension whose size does not equal 1. You cannot use the `dim` or `mode` inputs with a cell array.

Consider a two-dimensional input array, `A`:

- `sort(A,1)` sorts the elements in the columns of `A`.
- `sort(A,2)` sorts the elements in the rows of `A`.

# sort

---

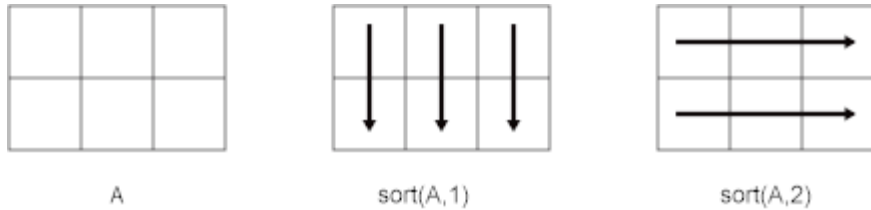

`sort` returns `A` if `dim` is greater than `ndims(A)`.

## mode - Sorting mode

'ascend' (default) | 'descend'

Sorting mode, specified as 'ascend' (default) or 'descend'. You cannot use the `dim` or `mode` options with a cell array.

**Example:** `sort(A,2,'descend')` sorts the rows of `A` in descending order.

## Data Types

char

## Output Arguments

### B - Sorted array

array

Sorted array, returned as an array of the same size and class as `A`. The ordering of the elements in `B` preserves the order of any equal elements in `A`.

### I - Sort index

collection of index vectors

Sort index, returned as a collection of index vectors. The index vectors are oriented along the same dimension that `sort` operates on. For example, if `A` is a 2-by-3 matrix, `[B,I] = sort(A,2)` sorts the elements in each row of `A` and `I` is a collection of 1-by-3 row index vectors describing the rearrangement. If you don't specify `dim`, then `[B,I] = sort(A)` sorts the columns of `A` and `I` is a collection of 2-by-1 column index vectors.

If A has repeated elements of equal value, the indices in I preserve the original ordering.

## Examples

### Sort Vector Elements

Create a row vector of random integers.

```
rng(0)
A = randi(10,1,10)
```

A =

```
 9 10 2 10 7 1 3 6 10 10
```

Sort the vector elements in ascending order.

```
B = sort(A)
```

B =

```
 1 2 3 6 7 9 10 10 10 10
```

The result, B, lists the integers from smallest to largest.

Alternatively, use the `mode` input to sort the vector in descending order.

```
C = sort(A, 'descend')
```

C =

```
 10 10 10 10 9 7 6 3 2 1
```

The result, C, lists the integers from largest to smallest.

### Sort Matrix Columns and Rows

Create a 5-by-5 matrix of random integers.

```
rng(1);
```

# sort

---

```
A = randi(100,5,5)
```

```
A =
```

```
 42 10 42 68 81
 73 19 69 42 97
 1 35 21 56 32
 31 40 88 15 70
 15 54 3 20 88
```

Sort the columns of A.

```
B = sort(A)
```

```
B =
```

```
 1 10 3 15 32
 15 19 21 20 70
 31 35 42 42 81
 42 40 69 56 88
 73 54 88 68 97
```

The result independently orders each column in ascending (smallest to largest) order.

Sort the rows of A in descending order using the `dim` and `mode` inputs.

```
B1 = sort(A,2, 'descend')
```

```
B1 =
```

```
 81 68 42 42 10
 97 73 69 42 19
 56 35 32 21 1
 88 70 40 31 15
 88 54 20 15 3
```

The result independently orders each row in descending (largest to smallest) order.

### Sort Complex Matrix Elements

Create a 4-by-2 matrix of complex numbers.

```
A = [1+1i 2-3i; -1-1i 4+3i; -1+1i 3+2i; 1-1i -2+3i]
```

A =

```

 1.0000 + 1.0000i 2.0000 - 3.0000i
 -1.0000 - 1.0000i 4.0000 + 3.0000i
 -1.0000 + 1.0000i 3.0000 + 2.0000i
 1.0000 - 1.0000i -2.0000 + 3.0000i
```

Sort the columns of A in ascending order.

```
B = sort(A)
```

B =

```

 -1.0000 - 1.0000i 2.0000 - 3.0000i
 1.0000 - 1.0000i 3.0000 + 2.0000i
 1.0000 + 1.0000i -2.0000 + 3.0000i
 -1.0000 + 1.0000i 4.0000 + 3.0000i
```

The `sort` function sorts complex elements first by absolute value (magnitude), then by phase angle.

Find the absolute values of the complex elements in A.

```
C = abs(A)
```

C =

```

 1.4142 3.6056
 1.4142 5.0000
 1.4142 3.6056
```

# sort

---

```
1.4142 3.6056
```

In this case, many of the elements in each column of A have equal magnitudes, so the value of `angle` largely determines the sorting order.

Evaluate the phase angles of each element in A.

```
P = angle(A)
```

```
P =
```

```
0.7854 -0.9828
-2.3562 0.6435
2.3562 0.5880
-0.7854 2.1588
```

The values in P determine the sort order for the column elements in A with equal magnitude in C.

## Sort Cell Array of Strings

Create a 3-by-3 cell array of strings.

```
A = {'Mud' 'Advent' 'Chair'; 'Truth' 'Jester' 'Fall'; 'Create' 'Double' 'Hyper'}
```

```
A =
```

```
'Mud' 'Advent' 'Chair'
'Truth' 'Jester' 'Fall'
'Create' 'Double' 'Hyper'
```

Sort the strings in the cell array in alphabetical order using `sort`.

```
[B,I] = sort(A)
```

```
B =
```

```
'Advent'
'Chair'
```



```
'Create'
'Double'
'Fall'
'Hyper'
'Jester'
'Mud'
'Truth'
```

```
I =
```

```
4
7
3
6
8
9
5
1
2
```

The result, **B**, is a 9-by-1 cell array with the strings in alphabetical order.

Use the index vector, **I**, to obtain **B** directly from **A**.

```
A(I)
```

```
ans =
```

```
'Advent'
'Chair'
'Create'
'Double'
'Fall'
'Hyper'
'Jester'
'Mud'
'Truth'
```

The result is the same as B because I describes the rearrangement of strings such that  $A(I) = B$ .

## Sort Multidimensional Array

Create a 2-by-2-by-3 multidimensional array of random integers.

```
rng(2);
A = randi(100,2,2,3)
```

```
A(:,:,1) =
```

```
 44 55
 3 44
```

```
A(:,:,2) =
```

```
 43 21
 34 62
```

```
A(:,:,3) =
```

```
 30 63
 27 53
```

Sort the columns on each page of the array.

```
B = sort(A)
```

```
B(:,:,1) =
```

```
 3 44
 44 55
```

```
B(:,:,2) =
```

```
34 21
43 62
```

```
B(:,:,3) =
```

```
27 53
30 63
```

The result orders the values in each column from smallest to largest.

Sort the array in the third (`dim = 3`) dimension.

```
[C,I] = sort(A,3)
```

```
C(:,:,1) =
```

```
30 21
3 44
```

```
C(:,:,2) =
```

```
43 55
27 53
```

```
C(:,:,3) =
```

```
44 63
34 62
```

```
I(:,:,1) =
```

```
3 2
1 1
```

## sort

---

```
I(:,:,2) =
```

```
 2 1
 3 3
```

```
I(:,:,3) =
```

```
 1 3
 2 2
```

The result, `C`, orders the corresponding elements on each page of `A` from smallest to largest. For example, `C(1,1,1) < C(1,1,2) < C(1,1,3)`. The corresponding elements on each page of `I` form 1-by-1-by-3 permutation vectors describing the rearrangement of the elements in `A` along the third dimension.

Verify the use of the index array with the original array, `A`.

```
for i = 1:size(A,1)
 for j = 1:size(A,2)
 D(i,j,:) = A(i,j,I(i,j,:));
 end
end
isequal(D,C)
```

```
ans =
```

```
 1
```

The result of logical `1` (`true`) confirms the validity of the index array, `I`. Since the permutation vectors are 3-D, two loops are required to use the indexing array.

**Tips**

- The `sortrows` function provides additional flexibility for subsorting over multiple columns of nonvector input arrays.
- The `sort` function and the relational operators use different orderings for complex numbers. For more information, see “Relational Operations”.

**See Also**

`issorted` | `max` | `mean` | `median` | `min` | `sortrows` | `unique`

**Concepts**

- “Shifting and Sorting Matrices”

# sortrows

---

**Purpose** Sort array rows

**Syntax**

```
B = sortrows(A)
B = sortrows(A,column)
[B,index] = sortrows(___)

tblB = sortrows(tblA)
tblB = sortrows(tblA,'RowNames')
tblB = sortrows(tblA,vars)

tblB = sortrows(tblA,mode)

tblB = sortrows(tblA,'RowNames',mode)
tblB = sortrows(tblA,vars,mode)

[tblB,index] = sortrows(tblA, ___)
```

**Description** `B = sortrows(A)` sorts the rows of `A` in ascending order. For strings, this is the familiar dictionary sort.

`B = sortrows(A, column)` sorts matrix `A` based on the columns specified in the vector, `column`. This input is used to perform multiple column sorts in succession.

`[B,index] = sortrows( ___ )` also returns an index vector using any of the previous syntaxes. The index vector satisfies `B = A(index,:)`.

`tblB = sortrows(tblA)` sorts the rows of table `tblA` in ascending order by the first variable, then by the second variable, and so on.

`tblB = sortrows(tblA,'RowNames')` sorts by the row names.

`tblB = sortrows(tblA,vars)` sorts by the variables specified by `vars`.

`tblB = sortrows(tblA,mode)` and `tblB = sortrows(tblA, 'RowNames',mode)` sorts `tblA` in the order specified by `mode`. The single string, 'ascend', indicates ascending order (default) and 'descend' indicates descending order.

`tblB = sortrows(tblA,vars,mode)` uses `mode` to specify the sort order. `mode` can be a single string or a cell array of strings containing 'ascend' for ascending order (default) or 'descend' for descending order.

- When `mode` is a single string, `sortrows` sorts in the specified direction for all variables in `vars`.
- When `mode` is a cell array of strings, `sortrows` sorts in the specified direction for each variable in `vars`.

`[tblB,index] = sortrows(tblA, ___)` also returns an index vector, `index`, such that `tblB = tblA(index,:)`.

## Input Arguments

### A - Input array

column vector | matrix

Input array, specified as a column vector or matrix of a numeric, logical, char, cell, or categorical class.

When `A` is complex, `sortrows` sorts the elements by magnitude, and, where magnitudes are equal, further sorts by phase angle on the interval  $[-\pi, \pi]$ .

**Complex Number Support:** Yes

### column - Column sorting vector

vector of integers

Column sorting vector, specified as a vector of integers. Each integer value indicates a column to sort by. The sign of the integer indicates ascending (positive) or descending (negative) sort order.

**Example:** `sortrows(A,[2 -3])` sorts the rows of `A` first in ascending order for the second column, and then it sorts by descending order for the third column.

## **tblA - Input table**

table

Input table, specified as a table. Each variable in `tblA` must be a valid input to `sort` or `sortrows`.

## **Data Types**

table

## **'RowNames' - Row sort input**

string

Row sort input, specified as the string `'RowNames'`. Specify the `'RowNames'` option to sort a table by row names rather than by variables. If `tblA.Properties.RowNames` is empty, `sortrows(tblA, 'RowNames')` returns `tblA`.

## **vars - Sorting variables**

integer | vector of integers | variable name | cell array of variable names | logical vector

Sorting variables, specified as an integer, a vector of integers, a variable name, a cell array of variable names, or a logical vector. `vars` indicates the table variables to sort by. You also can use the `mode` input to indicate ascending or descending order for each sorting variable.

If an element of `vars` is a positive integer, `sortrows` sorts the corresponding variable in `tblA` in ascending order. If an element of `vars` is a negative integer, `sortrows` sorts the corresponding variable in `tblA` in descending order. If you provide the `mode` input argument, MATLAB ignores the sign of the integers.

**Example:** `sortrows(tblA, {'Height', 'Weight'})` sorts the rows of `tblA` in ascending order, first by the variable `Height`, and then it sorts by the variable `Weight`.

**Example:** `sortrows(tblA, [1 4], {'descend' 'ascend'})` sorts the first variable of `tblA` in descending order, then it sorts the fourth variable in ascending order.



**mode - Sorting mode**

single string | cell array of strings

Sorting mode, specified as a single string or cell array of strings composed of the options 'ascend' (default), or 'descend'. If mode is a cell array of strings, the number of required entries depends on whether you are sorting by variables or by row names.

- If tblA is being sorted by variables, the cell array must have an entry for each variable.
- If tblA is being sorted by row names, the cell array must have one entry.

**Data Types**

char | cell

**Output Arguments****B - Sorted array**

array

Sorted array, returned as an array of the same size and class as A.

**tblB - Sorted table**

table

Sorted table, returned as a table with the same variables as tblA.

**index - Sort index**

index vector

Sort index, returned as an index vector. The sort index describes the rearrangement of elements or rows in the input.

**Examples****Sort Rows of Matrix**

Start with an arbitrary matrix, A.

```
A = floor(gallery('uniformdata',[6 7],0)*100);
A(1:4,1) = 95; A(5:6,1) = 76; A(2:4,2) = 7; A(3,3) = 73
```

# sortrows

---

```
A =
 95 45 92 41 13 1 84
 95 7 73 89 20 74 52
 95 7 73 5 19 44 20
 95 7 40 35 60 93 67
 76 61 93 81 27 46 83
 76 79 91 0 19 41 1
```

Sort the rows of A.

```
B = sortrows(A)
```

```
B =
 76 61 93 81 27 46 83
 76 79 91 0 19 41 1
 95 7 40 35 60 93 67
 95 7 73 5 19 44 20
 95 7 73 89 20 74 52
 95 45 92 41 13 1 84
```

When called with only a single input argument, `sortrows` bases the sort on the first column of the matrix. For any rows that have equal elements in a particular column, (e.g., `A(1:4,1)` for this matrix), sorting is based on the column immediately to the right, (`A(1:4,2)` in this case).

When called with two input arguments, `sortrows` bases the sort entirely on the column specified in the second argument.

Sort the rows of A based on the values in the second column.

```
C = sortrows(A,2)
```

```
C =
 95 7 73 89 20 74 52
 95 7 73 5 19 44 20
 95 7 40 35 60 93 67
 95 45 92 41 13 1 84
 76 61 93 81 27 46 83
 76 79 91 0 19 41 1
```

Rows that have equal elements in the specified column, (e.g., `A(2:4, :)`, if sorting matrix `A` by column 2) remain in their original order.

Specify two columns to sort by: columns 1 and 7.

```
D = sortrows(A, [1 7])
```

```
D =
 76 79 91 0 19 41 1
 76 61 93 81 27 46 83
 95 7 73 5 19 44 20
 95 7 73 89 20 74 52
 95 7 40 35 60 93 67
 95 45 92 41 13 1 84
```

`sortrows` sorts by column 1 first, and then for any rows with equal values in column 1, sorts by column 7.

Sort the rows in descending order using the values in column 4.

```
[E, index] = sortrows(A, -4)
```

```
E =
 95 7 73 89 20 74 52
 76 61 93 81 27 46 83
 95 45 92 41 13 1 84
 95 7 40 35 60 93 67
 95 7 73 5 19 44 20
 76 79 91 0 19 41 1
```

```
index =
```

```
 2
 5
 1
```

```
4
3
6
```

The index vector, `index`, describes the rearrangement of the rows, such that `E = A(index,:)`.

## Sort Rows of Cell Array

Create a 6-by-2 cell array of strings.

```
A = {'Germany' 'Lukas'; 'USA' 'William'; 'USA' 'Andrew'; ...
 'Germany' 'Andreas'; 'USA' 'Olivia'; 'Germany' 'Julia'}
```

```
A =
```

```
 'Germany' 'Lukas'
 'USA' 'William'
 'USA' 'Andrew'
 'Germany' 'Andreas'
 'USA' 'Olivia'
 'Germany' 'Julia'
```

The result is a list of countries and names.

Sort the rows of A.

```
B = sortrows(A)
```

```
B =
```

```
 'Germany' 'Andreas'
 'Germany' 'Julia'
 'Germany' 'Lukas'
 'USA' 'Andrew'
 'USA' 'Olivia'
 'USA' 'William'
```

The result is an alphabetized list sorted by both country and name.

Sort the names in the second column in descending order.

```
[C,index] = sortrows(A,[1 -2])
```

```
C =
```

```

'Germany' 'Lukas'
'Germany' 'Julia'
'Germany' 'Andreas'
'USA' 'William'
'USA' 'Olivia'
'USA' 'Andrew'

```

```
index =
```

```

1
6
4
2
5
3

```

The index vector, `index`, describes the rearrangement of the rows, such that `C = A(index,:)`.

### Sort Rows of Table

Sort the rows of a table by the variable values in ascending order.

Create a table with four variables listing patient information for five people.

```

LastName = {'Smith';'Johnson';'Williams';'Jones';'Brown'};
Age = [38;43;38;40;49];
Height = [71;69;64;67;64];
Weight = [176;163;131;133;119];
BloodPressure = [124 93; 109 77; 125 83; 117 75; 122 80];

```

## sortrows

---

```
tblA = table(Age,Height,Weight,BloodPressure,'RowNames',LastName)
```

```
tblA =
```

	Age	Height	Weight	BloodPressure	
	---	-----	-----	-----	-----
Smith	38	71	176	124	93
Johnson	43	69	163	109	77
Williams	38	64	131	125	83
Jones	40	67	133	117	75
Brown	49	64	119	122	80

Sort the rows of the table.

```
tblB = sortrows(tblA)
```

```
tblB =
```

	Age	Height	Weight	BloodPressure	
	---	-----	-----	-----	-----
Williams	38	64	131	125	83
Smith	38	71	176	124	93
Jones	40	67	133	117	75
Johnson	43	69	163	109	77
Brown	49	64	119	122	80

The `sortrows` function sorts the rows in ascending order first by the variable `Age`, and then it sorts by the variable `Height`.

### Sort Rows of Table by Row Names

Create a table with four variables listing patient information for five people.

```
LastName = {'Smith';'Johnson';'Williams';'Jones';'Brown'};
Age = [38;43;38;40;49];
Height = [71;69;64;67;64];
Weight = [176;163;131;133;119];
```

```
BloodPressure = [124 93; 109 77; 125 83; 117 75; 122 80];
```

```
tblA = table(Age,Height,Weight,BloodPressure,'RowNames',LastName)
```

```
tblA =
```

	Age	Height	Weight	BloodPressure	
	---	-----	-----	-----	-----
Smith	38	71	176	124	93
Johnson	43	69	163	109	77
Williams	38	64	131	125	83
Jones	40	67	133	117	75
Brown	49	64	119	122	80

Sort the rows of the table by the row names and return an index vector, such that `tblB = tblA(index,:)`.

```
[tblB,index] = sortrows(tblA,'RowNames')
```

```
tblB =
```

	Age	Height	Weight	BloodPressure	
	---	-----	-----	-----	-----
Brown	49	64	119	122	80
Johnson	43	69	163	109	77
Jones	40	67	133	117	75
Smith	38	71	176	124	93
Williams	38	64	131	125	83

```
index =
```

```
5
2
4
1
3
```

The `sortrows` function sorts the rows in ascending order by the row names.

## Sort Rows of Table by Variables

Create a table with four variables listing patient information for five people.

```
LastName = {'Smith';'Johnson';'Williams';'Jones';'Brown'};
Age = [38;43;38;40;49];
Height = [71;69;64;67;64];
Weight = [176;163;131;133;119];
BloodPressure = [124 93; 109 77; 125 83; 117 75; 122 80];
```

```
tblA = table(Age,Height,Weight,BloodPressure,'RowNames',LastName)
```

```
tblA =
```

	Age	Height	Weight	BloodPressure	
	---	-----	-----	-----	-----
Smith	38	71	176	124	93
Johnson	43	69	163	109	77
Williams	38	64	131	125	83
Jones	40	67	133	117	75
Brown	49	64	119	122	80

Sort the rows of the table in ascending order by `Height`, and then sort in descending order by `Weight`. Also, return an index vector, such that `tblB = tblA(index,:)`.

```
[tblB,index] = sortrows(tblA,{'Height','Weight'},{'ascend','descend'})
```

```
tblB =
```

	Age	Height	Weight	BloodPressure	
	---	-----	-----	-----	-----
Williams	38	64	131	125	83
Brown	49	64	119	122	80
Jones	40	67	133	117	75



Johnson	43	69	163	109	77
Smith	38	71	176	124	93

index =

3  
5  
4  
2  
1

**See Also**

issorted | sort

# sound

---

## Purpose

Convert matrix of signal data to sound

## Syntax

```
sound(y)
sound(y,Fs)
sound(y,Fs,nBits)
```

## Description

`sound(y)` sends audio signal `y` to the speaker at the default sample rate of 8192 hertz.

`sound(y,Fs)` sends audio signal `y` to the speaker at sample rate `Fs`.

`sound(y,Fs,nBits)` uses `nBits` bits per sample for audio signal `y`.

## Input Arguments

### **y** - Audio data

column vector |  $m$ -by-2 matrix

Audio data, specified as an  $m$ -by-1 column vector for single-channel (mono) audio, or an  $m$ -by-2 matrix for stereo playback, where  $m$  is the number of audio samples. If `y` is an  $m$ -by-2 matrix, then the first column corresponds to the left channel, and the second column corresponds to the right channel. Stereo playback is available only if your system supports it.

### Data Types

double

### **Fs** - Sample rate

8192 (default) | positive number

Sample rate, in hertz, of audio data `y`, specified as a positive number between 80 and 1000000.

### Data Types

single | double

### **nBits** - Bit depth of sample values

8 (default) | 16 | 24

Bit depth of the sample values, specified as an integer. Valid values depend on the audio hardware installed. Most platforms support bit depths of 8 bits or 16 bits.

## Examples

### Play Sample Data at Default Sample Rate

Load the example file `gong.mat`, which contains sample data `y` and rate `Fs`, and listen to the audio.

```
load gong.mat;
sound(y);
```

### Play Sample Data at Specific Sample Rate

Play an excerpt from Handel's "Hallelujah Chorus" at twice the recorded sample rate.

```
load handel.mat;
sound(y, 2*Fs);
```

### Play Sample Data with Specific Bit Depth

```
load handel.mat;
nBits = 16;
sound(y, Fs, nBits);
```

MATLAB plays the audio with a bit depth of 16 bits per sample, if this is supported on your system.

## Tips

- The `sound` function supports sound devices on all Windows and most UNIX platforms.
- Most sound cards support sample rates between 5 and 48 kilohertz. Specifying a sample rate outside this range might produce unexpected results.

## See Also

`audioplayer` | `soundsc` | `audioread` | `audiowrite`

# sound

---

## **Concepts**

- “Characteristics of Audio Files”
- “Play Audio”

**Purpose**

Scale data and play as sound

**Syntax**

```
soundsc(y)
soundsc(y,Fs)
soundsc(y,Fs,nBits)

soundsc(__ ,yRange)
```

**Description**

`soundsc(y)` scales the values of audio signal `y` to fit in the range from  $-1.0$  to  $1.0$ , and then sends the data to the speaker at the default sample rate of 8192 hertz. By first scaling the data, `soundsc` plays the audio as loudly as possible without clipping. The mean of the dynamic range of the data is set to zero.

`soundsc(y,Fs)` sends audio signal `y` to the speaker at sample rate `Fs`.

`soundsc(y,Fs,nBits)` uses `nBits` bits per sample for audio signal `y`.

`soundsc( __ ,yRange)`, where `yRange` is a vector of the form `[low,high]`, linearly scales the values in `y` between `low` and `high` to the full sound range `[-1.0,1.0]`. Values outside `[low,high]` are not clipped. You can use `yRange` with any of the input arguments in the above syntaxes.

**Input Arguments****y - Audio data**

column vector | m-by-2 matrix

Audio data, specified as an `m`-by-1 column vector for single-channel (mono) audio, or an `m`-by-2 matrix for stereo playback, where `m` is the number of audio samples. If `y` is an `m`-by-2 matrix, then the first column corresponds to the left channel, and the second column corresponds to the right channel. Stereo playback is available only if your system supports it.

**Data Types**

double

## **Fs - Sample rate**

8192 (default) | positive number

Sample rate, in hertz, of audio data  $y$ , specified as a positive number between 80 and 1000000.

## **Data Types**

single | double

## **nBits - Bit depth of sample values**

8 (default) | 16 | 24

Bit depth of the sample values, specified as an integer. Valid values depend on the audio hardware installed. Most platforms support bit depths of 8 bits or 16 bits.

## **yRange - Range of audio data to scale**

$[\min(y), \max(y)]$  (default) | two-element vector

Range of audio data to scale, specified as a two-element vector of the form  $[low, high]$ , where  $low$  and  $high$  are the lower and upper limits of the range.

**Example:**  $[-0.8, 0.8]$

## **Data Types**

double

## **Examples**

### **Play Sample Data at Default Sample Rate**

Load the example file `gong.mat`, which contains sample data  $y$  and rate  $F_s$ , and listen to the audio.

```
load gong.mat;
soundsc(y);
```

### **Play Sample Data at Specific Sample Rate**

Play an excerpt from Handel's "Hallelujah Chorus" at twice the recorded sample rate.

```
load handel.mat;
```

```
soundsc(y, 2*Fs);
```

### Play Sample Data with Specific Bit Depth

```
load handel.mat;
nBits = 16;
soundsc(y,Fs,nBits);
```

MATLAB plays the scaled audio with a bit depth of 16 bits per sample.

### Scale Selected Audio Data

```
load handel.mat;
yRange = [-0.7,0.7];
soundsc(y,yRange);
```

### Tips

- The sound function supports sound devices on all Windows and most UNIX platforms.
- Most sound cards support sample rates between 5 and 48 kilohertz. Specifying a sample rate outside this range might produce unexpected results.

### See Also

[audioplayer](#) | [sound](#) | [audioread](#) | [audiowrite](#)

# spalloc

---

**Purpose** Allocate space for sparse matrix

**Syntax** `S = spalloc(m,n,nzmax)`

**Description** `S = spalloc(m,n,nzmax)` creates an all zero sparse matrix `S` of size `m`-by-`n` with room to hold `nzmax` nonzeros. The matrix can then be generated column by column without requiring repeated storage allocation as the number of nonzeros grows.

`spalloc(m,n,nzmax)` is shorthand for

```
sparse([],[],[],m,n,nzmax)
```

**Examples** To generate efficiently a sparse matrix that has an average of at most three nonzero elements per column

```
S = spalloc(n,n,3*n);
for j = 1:n
 S(:,j) = [zeros(n-3,1)' round(rand(3,1))']';end
```



---

<b>Purpose</b>	Create sparse matrix
<b>Syntax</b>	<pre>S = sparse(A) S = sparse(i,j,s,m,n,nzmax) S = sparse(i,j,s,m,n) S = sparse(i,j,s) S = sparse(m,n)</pre>
<b>Description</b>	<p>The <code>sparse</code> function generates matrices in the MATLAB sparse storage organization.</p> <p><code>S = sparse(A)</code> converts a full matrix to sparse form by squeezing out any zero elements. If <code>S</code> is already sparse, <code>sparse(S)</code> returns <code>S</code>.</p> <p><code>S = sparse(i,j,s,m,n,nzmax)</code> uses vectors <code>i</code>, <code>j</code>, and <code>s</code> to generate an <code>m</code>-by-<code>n</code> sparse matrix such that <math>S(i(k),j(k)) = s(k)</math>, with space allocated for <code>nzmax</code> nonzeros. Vectors <code>i</code>, <code>j</code>, and <code>s</code> are all the same length. Any elements of <code>s</code> that are zero are ignored, along with the corresponding values of <code>i</code> and <code>j</code>. Any elements of <code>s</code> that have duplicate values of <code>i</code> and <code>j</code> are added together.</p> <hr/> <p><b>Note</b> If any value in <code>i</code> or <code>j</code> is larger than <math>2^{31}-1</math> for 32-bit platforms, or <math>2^{48}-1</math> on 64-bit platforms, then the sparse matrix cannot be constructed.</p> <hr/> <p>To simplify this six-argument call, you can pass scalars for the argument <code>s</code> and one of the arguments <code>i</code> or <code>j</code>—in which case they are expanded so that <code>i</code>, <code>j</code>, and <code>s</code> all have the same length.</p> <p><code>S = sparse(i,j,s,m,n)</code> uses <code>nzmax = length(s)</code>.</p> <p><code>S = sparse(i,j,s)</code> uses <code>m = max(i)</code> and <code>n = max(j)</code>. The maxima are computed before any zeros in <code>s</code> are removed, so one of the rows of <code>[i j s]</code> might be <code>[m n 0]</code>.</p> <p><code>S = sparse(m,n)</code> abbreviates <code>sparse([],[],[],m,n,0)</code>. This generates the ultimate sparse matrix, an <code>m</code>-by-<code>n</code> all zero matrix.</p>

## Tips

All of the MATLAB built-in arithmetic, logical, and indexing operations can be applied to sparse matrices, or to mixtures of sparse and full matrices. Operations on sparse matrices return sparse matrices and operations on full matrices return full matrices.

In most cases, operations on mixtures of sparse and full matrices return full matrices. The exceptions include situations where the result of a mixed operation is structurally sparse, for example,  $A * S$  is at least as sparse as  $S$ .

## Examples

`S = sparse(1:n,1:n,1)` generates a sparse representation of the  $n$ -by- $n$  identity matrix. The same  $S$  results from `S = sparse(eye(n,n))`, but this would also temporarily generate a full  $n$ -by- $n$  matrix with most of its elements equal to zero.

`B = sparse(10000,10000,pi)` is probably not very useful, but is legal and works; it sets up a 10000-by-10000 matrix with only one nonzero element. Don't try `full(B)`; it requires 800 megabytes of storage.

This dissects and then reassembles a sparse matrix:

```
[i,j,s] = find(S);
[m,n] = size(S);
S = sparse(i,j,s,m,n);
```

So does this, if the last row and column have nonzero entries:

```
[i,j,s] = find(S);
S = sparse(i,j,s);
```

## See Also

`diag` | `find` | `full` | `issparse` | `nnz` | `nonzeros` | `nzmax` | `spones` | `sprandn` | `sprandsym` | `spy`

**Purpose** Form least squares augmented system

**Syntax**  
 $S = \text{spaugment}(A, c)$   
 $S = \text{spaugment}(A)$

**Description**  $S = \text{spaugment}(A, c)$  creates the sparse, square, symmetric indefinite matrix  $S = [c \cdot I \ A; \ A' \ 0]$ . The matrix  $S$  is related to the least squares problem

$$\min \text{norm}(b - A \cdot x)$$

by

$$r = b - A \cdot x$$

$$S * [r/c; x] = [b; 0]$$

The optimum value of the residual scaling factor  $c$ , involves  $\min(\text{svd}(A))$  and  $\text{norm}(r)$ , which are usually too expensive to compute.

$S = \text{spaugment}(A)$  without a specified value of  $c$ , uses  $\max(\max(\text{abs}(A))) / 1000$ .

---

**Note** In previous versions of MATLAB product, the augmented matrix was used by sparse linear equation solvers, `\` and `/`, for nonsquare problems. Now, MATLAB software performs a least squares solve using the `qr` factorization of  $A$  instead.

---

**See Also** `spparms`

# spconvert

---

**Purpose** Import matrix from sparse matrix external format

**Syntax** `S = spconvert(D)`

**Description** `spconvert` is used to create sparse matrices from a simple sparse format easily produced by non-MATLAB sparse programs. `spconvert` is the second step in the process:

- 1 Load an ASCII data file containing `[i, j, v]` or `[i, j, re, im]` as rows into a MATLAB variable.
- 2 Convert that variable into a MATLAB sparse matrix.

`S = spconvert(D)` converts a matrix `D` with rows containing `[i, j, s]` or `[i, j, r, s]` to the corresponding sparse matrix. `D` must have an `nnz` or `nnz+1` row and three or four columns. Three elements per row generate a real matrix and four elements per row generate a complex matrix. A row of the form `[m n 0]` or `[m n 0 0]` anywhere in `D` can be used to specify `size(S)`. If `D` is already sparse, no conversion is done, so `spconvert` can be used after `D` is loaded from either a MAT-file or an ASCII file.

**Examples** Suppose the ASCII file `uphill.dat` contains

```
1 1 1.0000000000000000
1 2 0.5000000000000000
2 2 0.3333333333333333
1 3 0.3333333333333333
2 3 0.2500000000000000
3 3 0.2000000000000000
1 4 0.2500000000000000
2 4 0.2000000000000000
3 4 0.1666666666666667
4 4 0.142857142857143
4 4 0.0000000000000000
```

Then the statements

```
load uphill.dat
H = spconvert(uphill)
```

```
H =
(1,1) 1.0000
(1,2) 0.5000
(2,2) 0.3333
(1,3) 0.3333
(2,3) 0.2500
(3,3) 0.2000
(1,4) 0.2500
(2,4) 0.2000
(3,4) 0.1667
(4,4) 0.1429
```

recreate `sparse(triu(hilb(4)))`, possibly with roundoff errors. In this case, the last line of the input file is not necessary because the earlier lines already specify that the matrix is at least 4-by-4.

# spdiags

---

**Purpose** Extract and create sparse band and diagonal matrices

**Syntax**

```
B = spdiags(A)
[B,d] = spdiags(A)
B = spdiags(A,d)
A = spdiags(B,d,A)
A = spdiags(B,d,m,n)
```

**Description** The `spdiags` function generalizes the function `diag`. Four different operations, distinguished by the number of input arguments, are possible.

`B = spdiags(A)` extracts all nonzero diagonals from the  $m$ -by- $n$  matrix  $A$ .  $B$  is a  $\min(m,n)$ -by- $p$  matrix whose columns are the  $p$  nonzero diagonals of  $A$ .

`[B,d] = spdiags(A)` returns a vector  $d$  of length  $p$ , whose integer components specify the diagonals in  $A$ .

`B = spdiags(A,d)` extracts the diagonals specified by  $d$ .

`A = spdiags(B,d,A)` replaces the diagonals specified by  $d$  with the columns of  $B$ . The output is sparse.

`A = spdiags(B,d,m,n)` creates an  $m$ -by- $n$  sparse matrix by taking the columns of  $B$  and placing them along the diagonals specified by  $d$ .

---

**Note** In this syntax, if a column of  $B$  is longer than the diagonal it is replacing, and  $m \geq n$ , `spdiags` takes elements of super-diagonals from the lower part of the column of  $B$ , and elements of sub-diagonals from the upper part of the column of  $B$ . However, if  $m < n$ , then super-diagonals are from the upper part of the column of  $B$ , and sub-diagonals from the lower part. (See “Example 5A” on page 1-6402 and “Example 5B” on page 1-6404, below).

---

**Arguments** The `spdiags` function deals with three matrices, in various combinations, as both input and output.

- A An  $m$ -by- $n$  matrix, usually (but not necessarily) sparse, with its nonzero or specified elements located on  $p$  diagonals.
- B A  $\min(m, n)$ -by- $p$  matrix, usually (but not necessarily) full, whose columns are the diagonals of  $A$ .
- d A vector of length  $p$  whose integer components specify the diagonals in  $A$ .

Roughly,  $A$ ,  $B$ , and  $d$  are related by

```
for k = 1:p
 B(:,k) = diag(A,d(k))
end
```

Some elements of  $B$ , corresponding to positions outside of  $A$ , are not defined by these loops. They are not referenced when  $B$  is input and are set to zero when  $B$  is output.

### How the Diagonals of $A$ are Listed in the Vector $d$

An  $m$ -by- $n$  matrix  $A$  has  $m+n-1$  diagonals. These are specified in the vector  $d$  using indices from  $-m+1$  to  $n-1$ . For example, if  $A$  is 5-by-6, it has 10 diagonals, which are specified in the vector  $d$  using the indices -4, -3, ... 4, 5. The following diagram illustrates this for a vector of all ones.

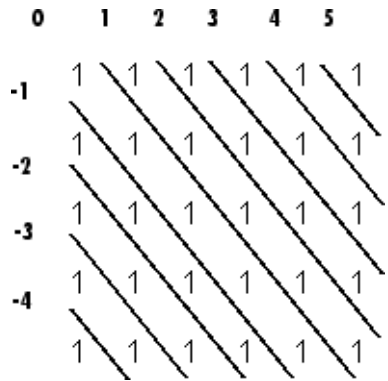

# spdiags

---

## Examples

### Example 1

For the following matrix,

```
A=[0 5 0 10 0 0;...
0 0 6 0 11 0;...
3 0 0 7 0 12;...
1 4 0 0 8 0;...
0 2 5 0 0 9]
```

A =

0	5	0	10	0	0
0	0	6	0	11	0
3	0	0	7	0	12
1	4	0	0	8	0
0	2	5	0	0	9

the command

```
[B, d] =spdiags(A)
```

returns

B =

0	0	5	10
0	0	6	11
0	3	7	12
1	4	8	0
2	5	9	0

d =

```
-3
-2
1
```



3

The columns of the first output **B** contain the nonzero diagonals of **A**. The second output **d** lists the indices of the nonzero diagonals of **A**, as shown in the following diagram. See “How the Diagonals of **A** are Listed in the Vector **d**” on page 1-6397.

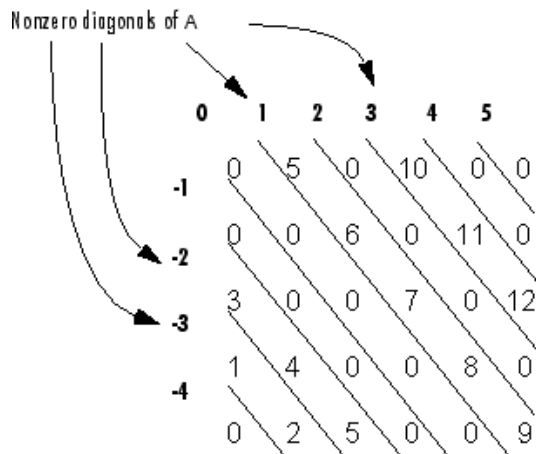

Note that the longest nonzero diagonal in **A** is contained in column 3 of **B**. The other nonzero diagonals of **A** have extra zeros added to their corresponding columns in **B**, to give all columns of **B** the same length. For the nonzero diagonals below the main diagonal of **A**, extra zeros are added at the tops of columns. For the nonzero diagonals above the main diagonal of **A**, extra zeros are added at the bottoms of columns. This is illustrated by the following diagram.

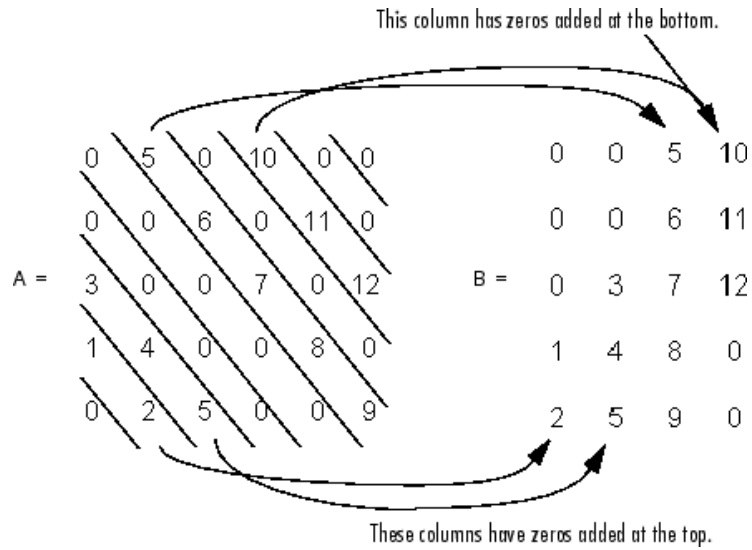

## Example 2

This example generates a sparse tridiagonal representation of the classic second difference operator on  $n$  points.

```
e = ones(n,1);
A = spdiags([e -2*e e], -1:1, n, n)
```

Turn it into Wilkinson's test matrix (see gallery):

```
A = spdiags(abs(-(n-1)/2:(n-1)/2)', 0, A)
```

Finally, recover the three diagonals:

```
B = spdiags(A)
```

## Example 3

The second example is not square.

```
A = [11 0 13 0
 0 22 0 24]
```

```

 0 0 33 0
 41 0 0 44
 0 52 0 0
 0 0 63 0
 0 0 0 74]

```

Here  $m = 7$ ,  $n = 4$ , and  $p = 3$ .

The statement `[B,d] = spdiags(A)` produces `d = [-3 0 2]'` and

```

B = [41 11 0
 52 22 0
 63 33 13
 74 44 24]

```

Conversely, with the above `B` and `d`, the expression `spdiags(B,d,7,4)` reproduces the original `A`.

#### Example 4

This example shows how `spdiags` creates the diagonals when the columns of `B` are longer than the diagonals they are replacing.

```
B = repmat((1:6)', [1 7])
```

```
B =
```

```

 1 1 1 1 1 1 1
 2 2 2 2 2 2 2
 3 3 3 3 3 3 3
 4 4 4 4 4 4 4
 5 5 5 5 5 5 5
 6 6 6 6 6 6 6

```

```
d = [-4 -2 -1 0 3 4 5];
```

```
A = spdiags(B,d,6,6);
```

```
full(A)
```

```
ans =
```

```
1 0 0 4 5 6
1 2 0 0 5 6
1 2 3 0 0 6
0 2 3 4 0 0
1 0 3 4 5 0
0 2 0 4 5 6
```

## Example 5A

This example illustrates the use of the syntax `A = spdiags(B,d,m,n)`, under three conditions:

- `m` is equal to `n`
- `m` is greater than `n`
- `m` is less than `n`

The command used in this example is

```
A = full(spdiags(B, [-2 0 2], m, n))
```

where `B` is the 5-by-3 matrix shown below. The resulting matrix `A` has dimensions `m`-by-`n`, and has nonzero diagonals at `[-2 0 2]` (a sub-diagonal at -2, the main diagonal, and a super-diagonal at 2).

```
B =
 1 6 11
 2 7 12
 3 8 13
 4 9 14
 5 10 15
```

The first and third columns of matrix `B` are used to create the sub- and super-diagonals of `A` respectively. In all three cases though, these two outer columns of `B` are longer than the resulting diagonals of `A`. Because of this, only a part of the columns is used in `A`.

When `m == n` or `m > n`, `spdiags` takes elements of the super-diagonal in `A` from the lower part of the corresponding column of `B`, and elements

of the sub-diagonal in A from the upper part of the corresponding column of B.

When  $m < n$ , spdiags does the opposite, taking elements of the super-diagonal in A from the upper part of the corresponding column of B, and elements of the sub-diagonal in A from the lower part of the corresponding column of B.

**Part 1 – m is equal to n.**

A = full(spdiags(B, [-2 0 2], 5, 5))

Matrix B		== spdiags ==>		Matrix A
1    6    11				6    0    13    0    0
2    7    12				0    7    0    14    0
3    8    13				1    0    8    0    15
4    9    14				0    2    0    9    0
5    10   15				0    0    3    0    10

A(3,1), A(4,2), and A(5,3) are taken from the upper part of B(:,1).

A(1,3), A(2,4), and A(3,5) are taken from the lower part of B(:,3).

**Part 2 – m is greater than n.**

A = full(spdiags(B, [-2 0 2], 5, 4))

Matrix B		== spdiags ==>		Matrix A
1    6    11				6    0    13    0
2    7    12				0    7    0    14
3    8    13				1    0    8    0
4    9    14				0    2    0    9
5    10   15				0    0    3    0

Same as in Part A.

**Part 3 – m is less than n.**

A = full(spdiags(B, [-2 0 2], 4, 5))

Matrix B				Matrix A				
1	6	11		6	0	11	0	0
2	7	12		0	7	0	12	0
3	8	13	== spdiags ==>	3	0	8	0	13
4	9	14		0	4	0	9	0
5	10	15						

A(3,1) and A(4,2) are taken from the lower part of B(:,1).

A(1,3), A(2,4), and A(3,5) are taken from the upper part of B(:,3).

## Example 5B

Extract the diagonals from the first part of this example back into a column format using the command

```
B = spdiags(A)
```

You can see that in each case the original columns are restored (minus those elements that had overflowed the super- and sub-diagonals of matrix A).

## Part 1.

Matrix A						Matrix B		
6	0	13	0	0		1	6	0
0	7	0	14	0		2	7	0
1	0	8	0	15	== spdiags ==>	3	8	13
0	2	0	9	0		0	9	14
0	0	3	0	10		0	10	15

## Part 2.

Matrix A					Matrix B		
6	0	13	0		1	6	0
0	7	0	14		2	7	0
1	0	8	0	== spdiags ==>	3	8	13

```
0 2 0 9 0 9 14
0 0 3 0
```

### Part 3.

```
 Matrix A Matrix B
6 0 11 0 0 0 6 11
0 7 0 12 0 0 7 12
3 0 8 0 13 == spdiags => 3 8 13
0 4 0 9 0 4 9 0
```

### See Also

[diag](#) | [speye](#)

# specular

---

**Purpose** Calculate specular reflectance

**Syntax** `R = specular(Nx,Ny,Nz,S,V)`

**Description** `R = specular(Nx,Ny,Nz,S,V)` returns the reflectance of a surface with normal vector components `[Nx,Ny,Nz]`. `S` and `V` specify the direction to the light source and to the viewer, respectively. You can specify these directions as three vectors `[x,y,z]` or two vectors `[Theta Phi]` (in spherical coordinates).

The specular highlight is strongest when the normal vector is in the direction of  $(S+V)/2$  where `S` is the source direction, and `V` is the view direction.

The surface spread exponent can be specified by including a sixth argument as in `specular(Nx,Ny,Nz,S,V,spread)`.



<b>Purpose</b>	Sparse identity matrix
<b>Syntax</b>	<code>S = speye(m,n)</code> <code>S = speye([m n])</code> <code>S = speye(n)</code> <code>S = speye</code>
<b>Description</b>	<code>S = speye(m,n)</code> and <code>S = speye([m n])</code> form an m-by-n sparse matrix with 1s on the main diagonal. <code>S = speye(n)</code> abbreviates <code>speye(n,n)</code> . <code>S = speye</code> returns the sparse form of the 1-by-1 identity matrix.
<b>Examples</b>	<code>I = speye(1000)</code> forms the sparse representation of the 1000-by-1000 identity matrix, which requires only about 16 kilobytes of storage. This is the same final result as <code>I = sparse(eye(1000,1000))</code> , but the latter requires eight megabytes for temporary storage for the full representation.
<b>See Also</b>	<code>spalloc</code>   <code>spones</code>   <code>spdiags</code>   <code>sprand</code>   <code>sprandn</code>

# spfun

---

**Purpose** Apply function to nonzero sparse matrix elements

**Syntax** `f = spfun(fun,S)`

**Description** The `spfun` function selectively applies a function to only the *nonzero* elements of a sparse matrix `S`, preserving the sparsity pattern of the original matrix (except for underflow or if `fun` returns zero for some nonzero elements of `S`).

`f = spfun(fun,S)` evaluates `fun(S)` on the elements of `S` that are nonzero. `fun` is a function handle.

“Parameterizing Functions” explains how to provide additional parameters to the function `fun`, if necessary.

**Tips** Functions that operate element-by-element, like those in the `elfun` directory, are the most appropriate functions to use with `spfun`.

**Examples** Given the 4-by-4 sparse diagonal matrix

```
S = spdiags([1:4]',0,4,4)
```

```
S =
 (1,1) 1
 (2,2) 2
 (3,3) 3
 (4,4) 4
```

Because `fun` returns nonzero values for all nonzero element of `S`, `f = spfun(@exp,S)` has the same sparsity pattern as `S`.

```
f =
 (1,1) 2.7183
 (2,2) 7.3891
 (3,3) 20.0855
 (4,4) 54.5982
```

whereas `exp(S)` has 1s where `S` has 0s.

```
full(exp(S))
```

```
ans =
```

```
 2.7183 1.0000 1.0000 1.0000
 1.0000 7.3891 1.0000 1.0000
 1.0000 1.0000 20.0855 1.0000
 1.0000 1.0000 1.0000 54.5982
```

**See Also**

```
function_handle
```

# sph2cart

---

**Purpose** Transform spherical coordinates to Cartesian

**Syntax** `[x,y,z] = sph2cart(azimuth,elevation,r)`

**Description** `[x,y,z] = sph2cart(azimuth,elevation,r)` transforms the corresponding elements of spherical coordinate arrays to Cartesian, or *xyz*, coordinates. *azimuth*, *elevation*, and *r* must all be the same size (or any of them can be scalar). *azimuth* and *elevation* are angular displacements in radians. *azimuth* is the counterclockwise angle in the *x-y* plane measured from the positive *x*-axis. *elevation* is the elevation angle from the *x-y* plane.

**Algorithms** The mapping from spherical coordinates to three-dimensional Cartesian coordinates is

```
x = r .* cos(elevation) .* cos(azimuth)
y = r .* cos(elevation) .* sin(azimuth)
z = r .* sin(elevation)
```

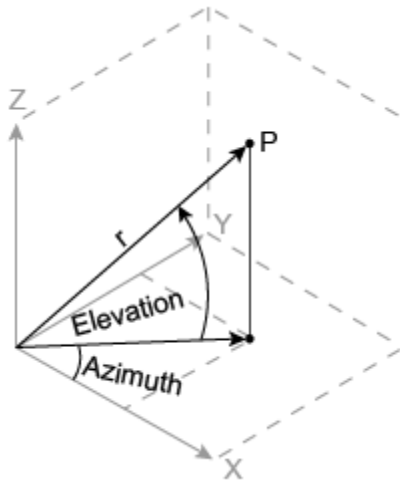

**See Also** `cart2pol` | `cart2sph` | `pol2cart`

## Purpose

Generate sphere



## Syntax

```
sphere
sphere(n)
[X,Y,Z] = sphere(n)
```

## Description

The `sphere` function generates the  $x$ -,  $y$ -, and  $z$ -coordinates of a unit sphere for use with `surf` and `mesh`.

`sphere` generates a sphere consisting of 20-by-20 faces.

`sphere(n)` draws a `surf` plot of an  $n$ -by- $n$  sphere in the current figure.

`[X,Y,Z] = sphere(n)` returns the coordinates of a sphere in three matrices that are  $(n+1)$ -by- $(n+1)$  in size. You draw the sphere with `surf(X,Y,Z)` or `mesh(X,Y,Z)`.

## Examples

### Plot Sphere

Generate and plot a sphere.

```
figure
sphere
```

# sphere

---

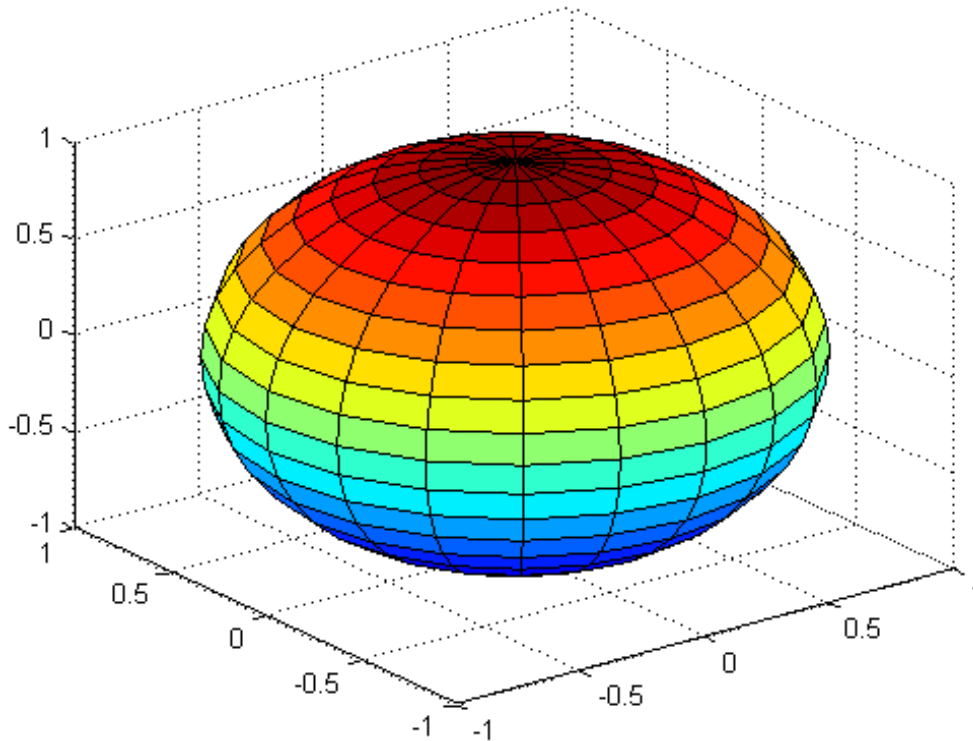

## Plot Multiple Spheres

Define  $x$ ,  $y$ , and  $z$  as coordinates of a sphere.

```
[x,y,z] = sphere;
```

Plot a sphere centered at the origin. Plot two more spheres centered at  $(3, -2, 0)$  and  $(0, 1, -3)$ .

```
figure
```

```
surf(x,y,z)

hold on
surf(x+3,y-2,z); % centered at (3,-2,0)
surf(x,y+1,z-3); % centered at (0,1,-3)
```

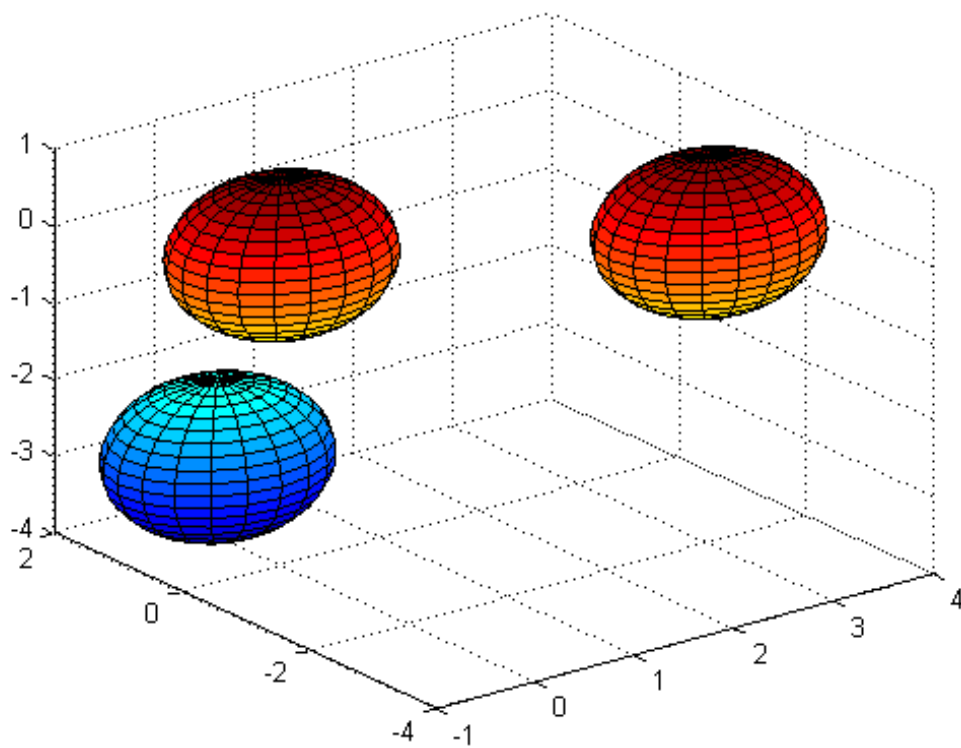

**See Also** [cylinder](#) | [axis](#)

# spinmap

---

**Purpose** Spin colormap

**Syntax** spinmap  
spinmap(t)  
spinmap(t,inc)  
spinmap('inf')

**Description** The spinmap function shifts the colormap RGB values by some incremental value. For example, if the increment equals 1, color 1 becomes color 2, color 2 becomes color 3, etc.

spinmap cyclically rotates the colormap for approximately five seconds using an incremental value of 2.

spinmap(t) rotates the colormap for approximately 10\*t seconds. The amount of time specified by t depends on your hardware configuration (e.g., if you are running MATLAB software over a network).

spinmap(t,inc) rotates the colormap for approximately 10\*t seconds and specifies an increment inc by which the colormap shifts. When inc is 1, the rotation appears smoother than the default (i.e., 2). Increments greater than 2 are less smooth than the default. A negative increment (e.g., -2) rotates the colormap in a negative direction.

spinmap('inf') rotates the colormap for an infinite amount of time. To break the loop, press **Ctrl+C**.

**See Also** colormap | colormapeditor



**Purpose** Cubic spline data interpolation

**Syntax**  
`yy = spline(x,Y,xx)`  
`pp = spline(x,Y)`

**Description** `yy = spline(x,Y,xx)` uses a cubic spline interpolation to find `yy`, the values of the underlying function `Y` at the values of the interpolant `xx`. For the interpolation, the independent variable is assumed to be the final dimension of `Y` with the breakpoints defined by `x`.

The sizes of `xx` and `yy` are related as follows:

- If `Y` is a scalar or vector, `yy` has the same size as `xx`.
- If `Y` is an array that is not a vector,
  - If `xx` is a scalar or vector, `size(yy)` equals `[d1, d2, ..., dk, length(xx)]`.
  - If `xx` is an array of size `[m1,m2,...,mj]`, `size(yy)` equals `[d1,d2,...,dk,m1,m2,...,mj]`.

`pp = spline(x,Y)` returns the piecewise polynomial form of the cubic spline interpolant for later use with `ppval` and the spline utility `unmkpp`. `x` must be a vector. `Y` can be a scalar, a vector, or an array of any dimension, subject to the following conditions:

- If `x` and `Y` are vectors of the same size, the not-a-knot end conditions are used.
- If `x` or `Y` is a scalar, it is expanded to have the same length as the other and the not-a-knot end conditions are used. (See Exceptions (1) below).
- If `Y` is a vector that contains two more values than `x` has entries, the first and last value in `Y` are used as the endslopes for the cubic spline. (See Exceptions (2) below.)

## Exceptions

- 1 If  $Y$  is a vector that contains two more values than  $x$  has entries, the first and last value in  $Y$  are used as the endslopes for the cubic spline. If  $Y$  is a vector, this means
  - $f(x) = Y(2:\text{end}-1)$
  - $df(\min(x)) = Y(1)$
  - $df(\max(x)) = Y(\text{end})$
- 2 If  $Y$  is a matrix or an  $N$ -dimensional array with  $\text{size}(Y,N)$  equal to  $\text{length}(x)+2$ , the following hold:
  - $f(x(j))$  matches the value  $Y(:, \dots, :, j+1)$  for  $j=1:\text{length}(x)$
  - $Df(\min(x))$  matches  $Y(:, :, \dots, 1)$
  - $Df(\max(x))$  matches  $Y(:, :, \dots, \text{end})$

---

**Note** You can also perform spline interpolation using the `interp1` function with the command `interp1(x,y,xx,'spline')`. Note that while `spline` performs interpolation on rows of an input matrix, `interp1` performs interpolation on columns of an input matrix.

---

## Examples

### Spline Interpolation of Sine Data

This generates a sine curve, then samples the spline over a finer mesh.

```
x = 0:10;
y = sin(x);
xx = 0:.25:10;
yy = spline(x,y,xx);
plot(x,y,'o',xx,yy)
```

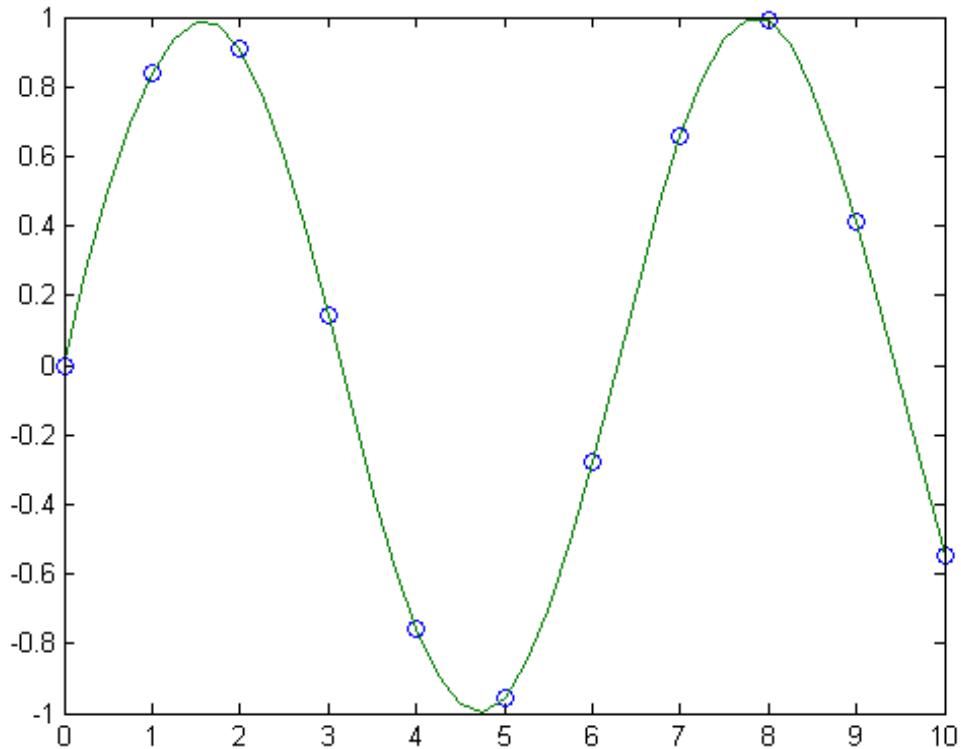

### Spline Interpolation of Distribution and Specify Endpoint Slopes

This illustrates the use of clamped or complete spline interpolation where end slopes are prescribed. Zero slopes at the ends of an interpolant to the values of a certain distribution are enforced.

```
x = -4:4;
y = [0 .15 1.12 2.36 2.36 1.46 .49 .06 0];
cs = spline(x,[0 y 0]);
```

# spline

---

```
xx = linspace(-4,4,101);
plot(x,y,'o',xx,ppval(cs,xx),'-');
```

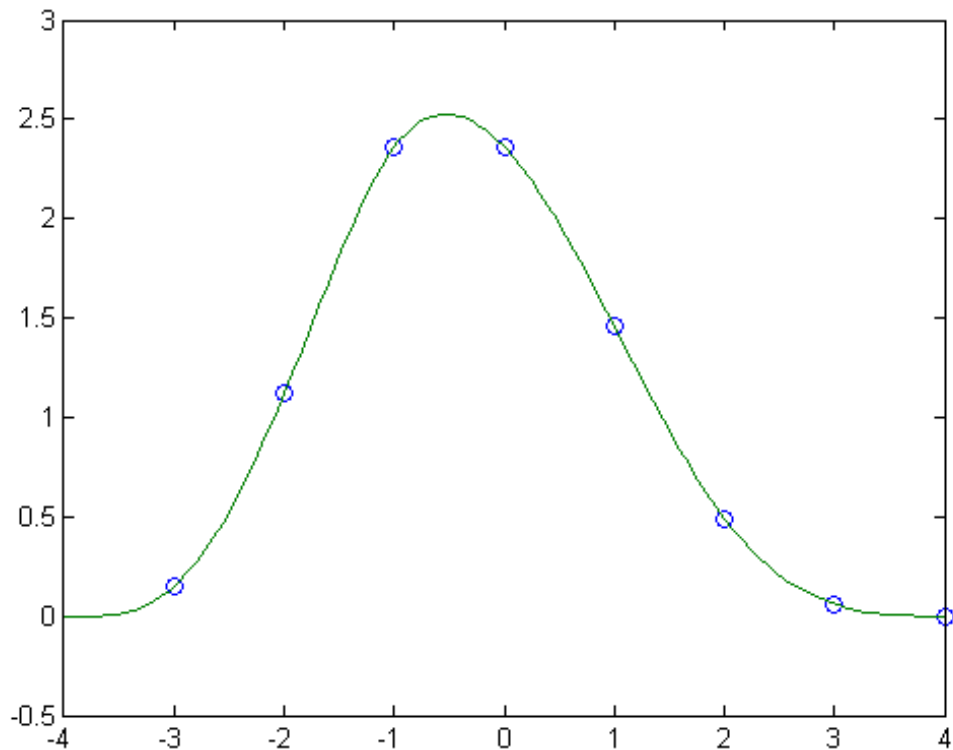

## Extrapolation Using Cubic Spline

The two vectors

```
t = 1900:10:1990;
p = [75.995 91.972 105.711 123.203 131.669 ...
 150.697 179.323 203.212 226.505 249.633];
```

represent the census years from 1900 to 1990 and the corresponding United States population in millions of people. The expression

```
spline(t,p,2000)
```

uses the cubic spline to extrapolate and predict the population in the year 2000. The result is

```
ans =
```

```
270.6060
```

### Spline Interpolation of Angular Data

The statements

```
x = pi*[0:.5:2];
y = [0 1 0 -1 0 1 0;
 1 0 1 0 -1 0 1];
pp = spline(x,y);
yy = ppval(pp, linspace(0,2*pi,101));
plot(yy(1,:),yy(2:,:), '-b',y(1,2:5),y(2,2:5),'or'), axis equal
```

generate the plot of a circle, with the five data points  $y(:,2), \dots, y(:,6)$  marked with o's. Note that this  $y$  contains two more values (i.e., two more columns) than does  $x$ , hence  $y(:,1)$  and  $y(:,end)$  are used as endslopes.

# spline

---

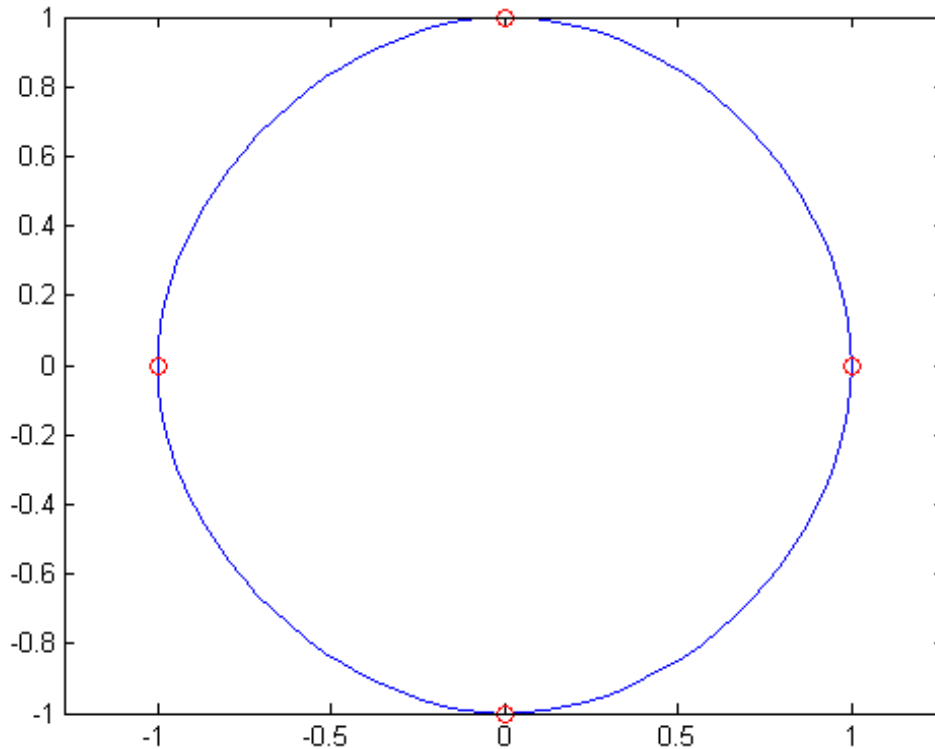

## Spline Interpolation of Sine and Cosine Data

The following code generates sine and cosine curves, then samples the splines over a finer mesh.

```
x = 0:.25:1;
Y = [sin(x); cos(x)];
xx = 0:.1:1;
YY = spline(x,Y,xx);
plot(x,Y(1,:), 'o',xx,YY(1,:), '-'); hold on;
```

```
plot(x,Y(2,:), 'o',xx,YY(2,:), ':'); hold off;
```

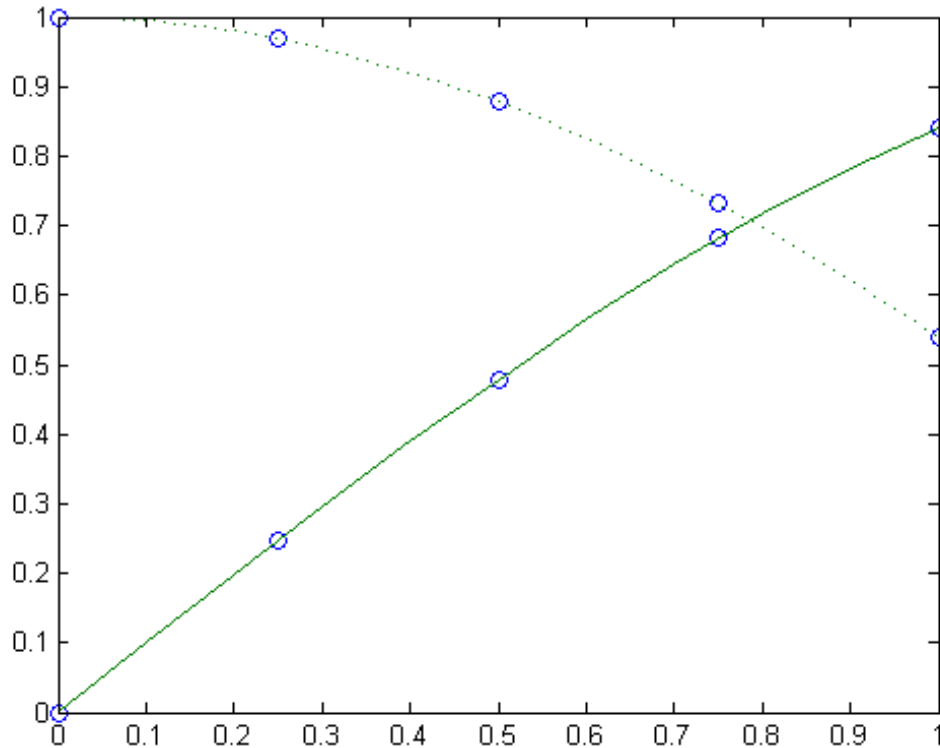

## Algorithms

A tridiagonal linear system (with, possibly, several right sides) is being solved for the information needed to describe the coefficients of the various cubic polynomials which make up the interpolating spline. `spline` uses the functions `ppval`, `mkpp`, and `unmkpp`. These routines form a small suite of functions for working with piecewise polynomials. For access to more advanced features, see the `interp1` reference page,

# spline

---

the command-line help for these functions, and the Curve Fitting Toolbox™ spline functions.

## References

[1] de Boor, C., *A Practical Guide to Splines*, Springer-Verlag, 1978.

## See Also

`interp1` | `ppval` | `mkpp` | `pchip` | `unmkpp`



<b>Purpose</b>	Replace nonzero sparse matrix elements with ones
<b>Syntax</b>	$R = \text{spones}(S)$
<b>Description</b>	$R = \text{spones}(S)$ generates a matrix $R$ with the same sparsity structure as $S$ , but with 1's in the nonzero positions.
<b>Examples</b>	$c = \text{sum}(\text{spones}(S))$ is the number of nonzeros in each column. $r = \text{sum}(\text{spones}(S'))'$ is the number of nonzeros in each row. $\text{sum}(c)$ and $\text{sum}(r)$ are equal, and are equal to $\text{nnz}(S)$ .
<b>See Also</b>	<code>nnz</code>   <code>spalloc</code>   <code>spfun</code>

# spparms

---

**Purpose** Set parameters for sparse matrix routines

**Syntax**

```
spparms('key',value)
spparms
values = spparms
[keys,values] = spparms
spparms(values)
value = spparms('key')
spparms('default')
spparms('tight')
```

**Description** spparms('key',value) sets one or more of the *tunable* parameters used in the sparse routines. In ordinary use, you should never need to deal with this function.

The meanings of the key parameters are

'spumoni'	Sparse Monitor flag:
0	Produces no diagnostic output, the default
1	Produces information about choice of algorithm based on matrix structure, and about storage allocation
2	Also produces very detailed information about the sparse matrix algorithms
'thr_rel', 'thr_abs'	Minimum degree threshold is thr_rel*mindegree + thr_abs.
'exact_d'	Nonzero to use exact degrees in minimum degree. Zero to use approximate degrees.
'supernd'	If positive, minimum degree amalgamates the supernodes every supernd stages.
'rreduce'	If positive, minimum degree does row reduction every rreduce stages.

'wh_frac'	Rows with <code>density &gt; wh_frac</code> are ignored in <code>colmmd</code> .
'autommd'	Nonzero to use minimum degree (MMD) orderings with QR-based \ and /.
'autoamd'	Nonzero to use <code>colamd</code> ordering with the LU-based \ and /, and to use <code>amd</code> with Cholesky-based \ and /.
'piv_tol'	Pivot tolerance used by the LU-based \ and /.
'bandden'	Band density used by \ and / for banded matrices. Band density is defined as $(\# \text{ nonzeros in the band})/(\# \text{ nonzeros in a full band})$ . If <code>bandden = 1.0</code> , never use band solver. If <code>bandden = 0.0</code> , always use band solver. Default is <code>0.5</code> .
'umfpack'	Nonzero to use UMFPACK instead of the v4 LU-based solver in \ and /.
'sym_tol'	Symmetric pivot tolerance. See <code>lu</code> for more information about the role of the symmetric pivot tolerance.

`spparms`, by itself, prints a description of the current settings.

`values = spparms` returns a vector whose components give the current settings.

`[keys, values] = spparms` returns that vector, and also returns a character matrix whose rows are the keywords for the parameters.

`spparms(values)`, with no output argument, sets all the parameters to the values specified by the argument vector.

`value = spparms('key')` returns the current setting of one parameter.

`spparms('default')` sets all the parameters to their default settings.

`spparms('tight')` sets the minimum degree ordering parameters to their *tight* settings, which can lead to orderings with less fill-in, but which make the ordering functions themselves use more execution time.

The key parameters for `default` and `tight` settings are

# spparms

---

	<b>Keyword</b>	<b>Default</b>	<b>Tight</b>
values(1)	'spumoni'	0.0	
values(2)	'thr_rel'	1.1	1.0
values(3)	'thr_abs'	1.0	0.0
values(4)	'exact_d'	0.0	1.0
values(5)	'supernd'	3.0	1.0
values(6)	'rreduce'	3.0	1.0
values(7)	'wh_frac'	0.5	0.5
values(8)	'autommd'	1.0	
values(9)	'autoamd'	1.0	
values(10)	'piv_tol'	0.1	
values(11)	'bandden'	0.5	
values(12)	'umfpack'	1.0	
values(13)	'sym_tol'	0.001	

## See Also

chol | lu | qr | colamd | symamd

---

<b>Purpose</b>	Sparse uniformly distributed random matrix
<b>Syntax</b>	<pre>R = sprand(S) R = sprand(m,n,density) R = sprand(m,n,density,rc)</pre>
<b>Description</b>	<p><code>R = sprand(S)</code> has the same sparsity structure as <code>S</code>, but uniformly distributed random entries.</p> <p><code>R = sprand(m,n,density)</code> is a random, <code>m</code>-by-<code>n</code>, sparse matrix with approximately <code>density*m*n</code> uniformly distributed nonzero entries (<code>0 &lt;= density &lt;= 1</code>).</p> <p><code>R = sprand(m,n,density,rc)</code> also has reciprocal condition number approximately equal to <code>rc</code>. <code>R</code> is constructed from a sum of matrices of rank one.</p> <p>If <code>rc</code> is a vector of length <code>lr</code>, where <code>lr &lt;= min(m,n)</code>, then <code>R</code> has <code>rc</code> as its first <code>lr</code> singular values, all others are zero. In this case, <code>R</code> is generated by random plane rotations applied to a diagonal matrix with the given singular values. It has a great deal of topological and algebraic structure.</p>
<b>Tips</b>	<ul style="list-style-type: none"><li>• <code>sprand</code> uses the same random number generator as <code>rand</code>, <code>randi</code>, and <code>randn</code>. You control this generator with <code>rng</code>.</li></ul>
<b>See Also</b>	<code>sprandn</code>   <code>sprandsym</code>

# sprandn

---

**Purpose** Sparse normally distributed random matrix

**Syntax**  
R = sprandn(S)  
R = sprandn(m,n,density)  
R = sprandn(m,n,density,rc)

**Description** R = sprandn(S) has the same sparsity structure as S, but normally distributed random entries with mean 0 and variance 1.

R = sprandn(m,n,density) is a random, m-by-n, sparse matrix with approximately  $\text{density} * m * n$  normally distributed nonzero entries ( $0 \leq \text{density} \leq 1$ ).

R = sprandn(m,n,density,rc) also has reciprocal condition number approximately equal to rc. R is constructed from a sum of matrices of rank one.

If rc is a vector of length lr, where  $lr \leq \min(m,n)$ , then R has rc as its first lr singular values, all others are zero. In this case, R is generated by random plane rotations applied to a diagonal matrix with the given singular values. It has a great deal of topological and algebraic structure.

**Tips**

- sprandn uses the same random number generator as rand, randi, and randn. You control this generator with rng.

**See Also** sprand | sprandsym

<b>Purpose</b>	Sparse symmetric random matrix
<b>Syntax</b>	<pre>R = sprandsym(S) R = sprandsym(n,density) R = sprandsym(n,density,rc) R = sprandsym(n,density,rc,kind) R = sprandsym(S,[],rc,3)</pre>
<b>Description</b>	<p><code>R = sprandsym(S)</code> returns a symmetric random matrix whose lower triangle and diagonal have the same structure as <code>S</code>. Its elements are normally distributed, with mean 0 and variance 1.</p> <p><code>R = sprandsym(n,density)</code> returns a symmetric random, <code>n</code>-by-<code>n</code>, sparse matrix with approximately <code>density*n*n</code> nonzeros; each entry is the sum of one or more normally distributed random samples, and (<code>0 &lt;= density &lt;= 1</code>).</p> <p><code>R = sprandsym(n,density,rc)</code> returns a matrix with a reciprocal condition number equal to <code>rc</code>. The distribution of entries is nonuniform; it is roughly symmetric about 0; all are in <code>[-1,1]</code>.</p> <p>If <code>rc</code> is a vector of length <code>n</code>, then <code>R</code> has eigenvalues <code>rc</code>. Thus, if <code>rc</code> is a positive (nonnegative) vector then <code>R</code> is a positive (nonnegative) definite matrix. In either case, <code>R</code> is generated by random Jacobi rotations applied to a diagonal matrix with the given eigenvalues or condition number. It has a great deal of topological and algebraic structure.</p> <p><code>R = sprandsym(n,density,rc,kind)</code> is positive definite.</p> <ul style="list-style-type: none"><li>• If <code>kind = 1</code>, <code>R</code> is generated by random Jacobi rotation of a positive definite diagonal matrix. <code>R</code> has the desired condition number exactly.</li><li>• If <code>kind = 2</code>, <code>R</code> is a shifted sum of outer products. <code>R</code> has the desired condition number only approximately, but has less structure.</li></ul> <p><code>R = sprandsym(S,[],rc,3)</code> has the same structure as the matrix <code>S</code> and approximate condition number <code>1/rc</code>.</p>
<b>Tips</b>	<code>sprandsym</code> uses the same random number generator as <code>rand</code> , <code>randi</code> , and <code>randn</code> . You control this generator with <code>rng</code> .

# sprandsym

---

## See Also

sprand | sprandn



<b>Purpose</b>	Structural rank
<b>Syntax</b>	<code>r = sprank(A)</code>
<b>Description</b>	<p><code>r = sprank(A)</code> is the structural rank of the sparse matrix <code>A</code>. For all values of <code>A</code>,</p> $\text{sprank}(A) \geq \text{rank}(\text{full}(A))$ <p>In exact arithmetic, <math>\text{sprank}(A) == \text{rank}(\text{full}(\text{sprandn}(A)))</math> with a probability of one.</p>
<b>Examples</b>	<pre>A = [1    0    2    0       2    0    4    0 ];  A = sparse(A);  sprank(A)  ans =      2  rank(full(A))  ans =      1</pre>
<b>See Also</b>	<code>dmperm</code>

# sprintf

---

**Purpose** Format data into string

**Syntax**  
`str = sprintf(formatSpec,A1,...,An)`  
`[str,errmsg] = sprintf(formatSpec,A1,...,An)`

**Description** `str = sprintf(formatSpec,A1,...,An)` formats the data in arrays `A1,...,An` according to `formatSpec` in column order, and returns the results to string `str`.

`[str,errmsg] = sprintf(formatSpec,A1,...,An)` returns an error message string when the operation is unsuccessful. Otherwise, `errmsg` is empty.

## Input Arguments

### **formatSpec - Format of the output fields**

string

Format of the output fields, specified as a string.

The string can include a percent sign followed by a conversion character. The following table lists the available conversion characters and subtypes.

Value Type	Conversion	Details
Integer, signed	%d or %i	Base 10
Integer, unsigned	%u	Base 10
	%o	Base 8 (octal)
	%x	Base 16 (hexadecimal), lowercase letters a–f
	%X	Same as %x, uppercase letters A–F

Value Type	Conversion	Details
Floating-point number	%f	Fixed-point notation
	%e	Exponential notation, such as 3.141593e+00
	%E	Same as %e, but uppercase, such as 3.141593E+00
	%g	The more compact of %e or %f, with no trailing zeros
	%G	The more compact of %E or %f, with no trailing zeros
	%bx or %bX %bo %bu	Double-precision hexadecimal, octal, or decimal value Example: %bx prints pi as 400921fb54442d18
	%tx or %tX %to %tu	Single-precision hexadecimal, octal, or decimal value Example: %tx prints pi as 40490fdb
Characters	%c	Single character
	%s	String of characters

The string can include optional operators, which appear in the following order (includes spaces for clarity):

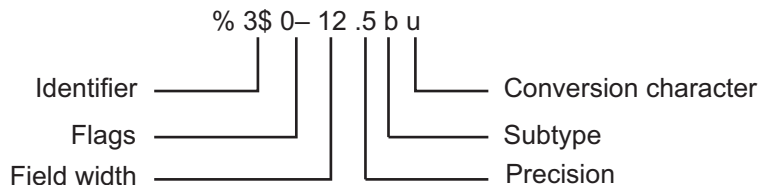

Optional operators include:

# sprintf

---

- Identifier

Order for processing inputs. Use the syntax *n*\$, where *n* represents the position of the value in the input list.

For example, '%3\$s %2\$s %1\$s %2\$s' prints inputs 'A', 'B', 'C' as follows: C B A B.

- Flags

' ' Left-justify. Example: %-5.2f

'+' Print sign character (+) for positive values. Example: %+5.2f

' ' Pad to field width with spaces before the value. Example: % 5.2f

'0' Pad to field width with zeros. Example: %05.2f

'#' Modify selected numeric conversions:

- For %o, %x, or %X, print 0, 0x, or 0X prefix.
- For %f, %e, or %E, print decimal point even when precision is 0.
- For %g or %G, do not remove trailing zeros or decimal point.

Example: %#5.0f

- Field width

Minimum number of characters to print. Can be a number, or an asterisk (\*) to refer to an argument in the input list. For example, the input list ('%12d', intmax) is equivalent to ('%\*d', 12, intmax).

- Precision

For %f, %e, or %E:      Number of digits to the right of the decimal point.  
 Example: '%6.4f' prints pi as '3.1416'

For %g or %G            Number of significant digits.  
 Example: '%6.4g' prints pi as ' 3.142'

Can be a number, or an asterisk (\*) to refer to an argument in the input list. For example, the input list ('%6.4f', pi) is equivalent to ('%\*.\*f', 6, 4, pi).

The string can also include combinations of the following:

- Literal text to print. To print a single quotation mark, include '' in formatSpec.
- Control characters, including:

%%	Percent character
\\	Backslash
\a	Alarm
\b	Backspace
\f	Form feed
\n	New line
\r	Carriage return
\t	Horizontal tab
\v	Vertical tab
\xN	Character whose ASCII code is the hexadecimal number, N
\N	Character whose ASCII code is the octal number, N

The following limitations apply to conversions:

# sprintf

---

- Numeric conversions print only the real component of complex numbers.
- If you specify a conversion that does not fit the data, such as a string conversion for a numeric value, MATLAB overrides the specified conversion, and uses %e.
- If you apply a string conversion (%s) to integer values, MATLAB converts values that correspond to valid character codes to characters. For example, '%s' converts [65 66 67] to ABC.

## **A1,...,An - Numeric or character arrays**

scalar | vector | matrix | multidimensional array

Numeric or character arrays, specified as a scalar, vector, matrix, or multidimensional array.

## **Data Types**

single | double | int8 | int16 | int32 | int64 | uint8 |  
uint16 | uint32 | uint64 | logical | char

## **Output Arguments**

### **str - Formatted text**

string

Formatted text, returned as a string.

### **errmsg - Error message**

string

Error message, returned as a string, when the operation is unsuccessful. Otherwise, errmsg is empty.

## **Tips**

- The sprintf function is similar to fprintf, but fprintf prints to a file or to the Command Window.
- Format specifiers for the reading functions sscanf and fscanf differ from the formats for the writing functions sprintf and fprintf. The reading functions do not support a precision field. The width field specifies a minimum for writing but a maximum for reading.

## Examples

### Floating-Point Formats

Format a floating-point number using %e, %f, and %g specifiers.

```
A = 1/eps;
str_e = sprintf('%0.5e',A)
str_f = sprintf('%0.5f',A)
str_g = sprintf('%0.5g',A)
```

```
str_e =
4.50360e+15
```

```
str_f =
4503599627370496.00000
```

```
str_g =
4.5036e+15
```

### Literal Text and Array Inputs

Combine literal text with array values to create a string.

```
formatSpec = 'The array is %dx%d.';
A1 = 2;
A2 = 3;
str = sprintf(formatSpec,A1,A2)
```

```
str =
The array is 2x3.
```

### Integer Format with Floating-Point Inputs

Explicitly convert double-precision values to integers.

```
str = sprintf('%d',round(pi))
```

```
str =
3
```

# sprintf

---

## Field Width

Specify the minimum width of the printed value.

```
str = sprintf('%025d',[123456])

str =
00000000000000000000000123456
```

The 0 flag in the %025d format specifier requests leading zeros in the output.

## Position Identifier (n\$)

Reorder the input values using the n\$ position identifier.

```
A1 = 'X';
A2 = 'Y';
A3 = 'Z';
formatSpec = ' %3$s %2$s %1$s';
str = sprintf(formatSpec,A1,A2,A3)

str =
 Z Y X
```

## Cell Array Inputs

Create a string from values in a cell array.

```
C = { 1, 2, 3 ;
 'AA', 'BB', 'CC' };

str = sprintf(' %d %s',C{:})

str =
 1 AA 2 BB 3 CC
```

The syntax C{:} creates a comma-separated list of arrays that contain the contents of each cell from C in column order. For example, C{1}==1 and C{2}=='AA'.



## References

[1] Kernighan, B. W., and D. M. Ritchie, *The C Programming Language*, Second Edition, Prentice-Hall, Inc., 1988.

[2] ANSI specification X3.159-1989: “Programming Language C,” ANSI, 1430 Broadway, New York, NY 10018.

## See Also

`char` | `fprintf` | `int2str` | `num2str` | `sscanf` | `fscanf`

## Concepts

- “Formatting Strings”

**Purpose** Visualize sparsity pattern

**Syntax**

```
spy(S)
spy(S,markersize)
spy(S,'LineStyle')
spy(S,'LineStyle',markersize)
```

**Description** `spy(S)` plots the sparsity pattern of any matrix `S`.

`spy(S,markersize)`, where `markersize` is an integer, plots the sparsity pattern using markers of the specified point size.

`spy(S,'LineStyle')`, where `LineStyle` is a string, uses the specified plot marker type and color.

`spy(S,'LineStyle',markersize)` uses the specified type, color, and size for the plot markers.

`S` is usually a sparse matrix, but full matrices are acceptable, in which case the locations of the nonzero elements are plotted.

---

**Note** `spy` replaces `format +`, which takes much more space to display essentially the same information.

---

## Examples

### Plot Sparsity Pattern

This example plots the 60-by-60 sparse adjacency matrix of the connectivity graph of the Buckminster Fuller geodesic dome. This matrix also represents the soccer ball and the carbon-60 molecule.

```
B = bucky;
spy(B)
```

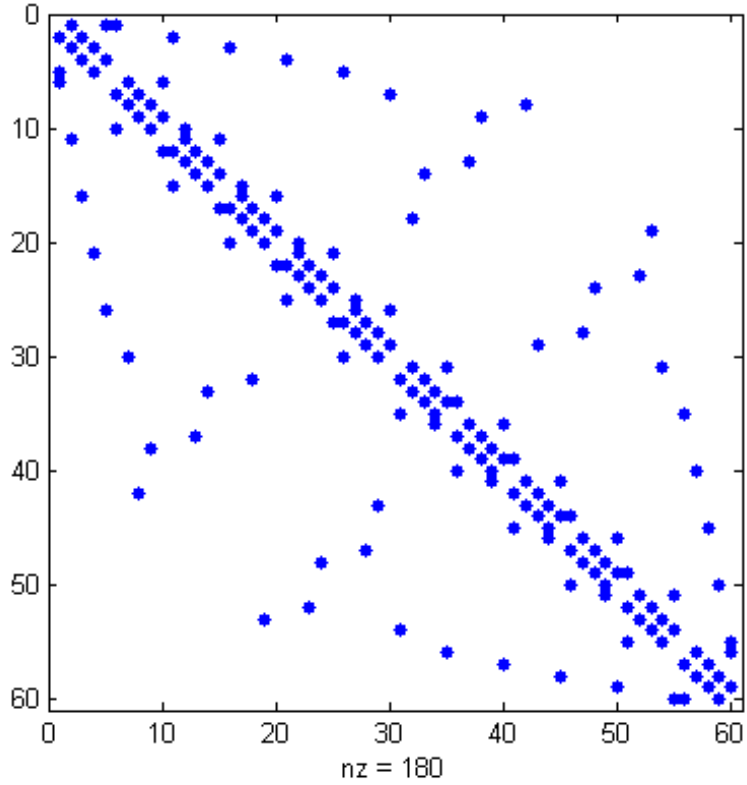

**See Also** [find](#) | [gplot](#) | [LineSpec](#) | [symamd](#) | [symrcm](#)

# sqrt

---

**Purpose** Square root

**Syntax** `B = sqrt(X)`

**Description** `B = sqrt(X)` returns the square root of each element of the array `X`. For the elements of `X` that are negative or complex, `sqrt(X)` produces complex results.

**Tips** See `sqrtm` for the matrix square root.

**Examples**

```
sqrt((-2:2)')
ans =
 0 + 1.4142i
 0 + 1.0000i
 0
 1.0000
 1.4142
```

**See Also** `nthroot` | `sqrtm` | `realsqrt`

<b>Purpose</b>	Matrix square root
<b>Syntax</b>	<pre>X = sqrtm(A) [X, resnorm] = sqrtm(A) [X, alpha, condest] = sqrtm(A)</pre>
<b>Description</b>	<p><math>X = \text{sqrtm}(A)</math> is the principal square root of the matrix <math>A</math>, i.e. <math>X^2 = A</math>. <math>X</math> is the unique square root for which every eigenvalue has nonnegative real part. If <math>A</math> has any eigenvalues with negative real parts then a complex result is produced. If <math>A</math> is singular then <math>A</math> may not have a square root. A warning is printed if exact singularity is detected.</p> <p><math>[X, \text{resnorm}] = \text{sqrtm}(A)</math> does not print any warning, and returns the residual, <math>\text{norm}(A - X^2, 'fro') / \text{norm}(A, 'fro')</math>.</p> <p><math>[X, \text{alpha}, \text{condest}] = \text{sqrtm}(A)</math> returns a stability factor <math>\text{alpha}</math> and an estimate <math>\text{condest}</math> of the matrix square root condition number of <math>X</math>. The residual <math>\text{norm}(A - X^2, 'fro') / \text{norm}(A, 'fro')</math> is bounded approximately by <math>n * \text{alpha} * \text{eps}</math> and the Frobenius norm relative error in <math>X</math> is bounded approximately by <math>n * \text{alpha} * \text{condest} * \text{eps}</math>, where <math>n = \max(\text{size}(A))</math>.</p>
<b>Tips</b>	<p>If <math>A</math> is real, symmetric and positive definite, or complex, Hermitian and positive definite, then so is the computed matrix square root.</p> <p>Some matrices, like <math>A = \begin{bmatrix} 0 &amp; 1 \\ 0 &amp; 0 \end{bmatrix}</math>, do not have any square roots, real or complex, and <code>sqrtm</code> cannot be expected to produce one.</p>
<b>Examples</b>	<p><b>Example 1</b></p> <p>A matrix representation of the fourth difference operator is</p> <pre>A =      5    -4     1     0     0     -4     6    -4     1     0      1    -4     6    -4     1      0     1    -4     6    -4      0     0     1    -4     5</pre>

This matrix is symmetric and positive definite. Its unique positive definite square root,  $Y = \text{sqrtm}(A)$ , is a representation of the second difference operator.

$$Y = \begin{bmatrix} 2 & -1 & -0 & -0 & -0 \\ -1 & 2 & -1 & 0 & -0 \\ 0 & -1 & 2 & -1 & 0 \\ -0 & 0 & -1 & 2 & -1 \\ -0 & -0 & -0 & -1 & 2 \end{bmatrix}$$

## Example 2

The matrix

$$A = \begin{bmatrix} 7 & 10 \\ 15 & 22 \end{bmatrix}$$

has four square roots. Two of them are

$$Y1 = \begin{bmatrix} 1.5667 & 1.7408 \\ 2.6112 & 4.1779 \end{bmatrix}$$

and

$$Y2 = \begin{bmatrix} 1 & 2 \\ 3 & 4 \end{bmatrix}$$

The other two are  $-Y1$  and  $-Y2$ . All four can be obtained from the eigenvalues and vectors of  $A$ .

$$[V,D] = \text{eig}(A);$$
$$D = \begin{bmatrix} 0.1386 & 0 \\ 0 & 28.8614 \end{bmatrix}$$

The four square roots of the diagonal matrix D result from the four choices of sign in

$$S = \begin{pmatrix} -0.3723 & 0 \\ 0 & -5.3723 \end{pmatrix}$$

All four Ys are of the form

$$Y = V*S/V$$

The sqrtm function chooses the two plus signs and produces Y1, even though Y2 is more natural because its entries are integers.

### See Also

expm | funm | logm

# squeeze

---

**Purpose** Remove singleton dimensions

**Syntax** `B = squeeze(A)`

**Description** `B = squeeze(A)` returns an array `B` with the same elements as `A`, but with all singleton dimensions removed. A singleton dimension is any dimension for which `size(A,dim) = 1`. Two-dimensional arrays are unaffected by `squeeze`; if `A` is a row or column vector or a scalar (1-by-1) value, then `B = A`.

**Examples** Consider the 2-by-1-by-3 array `Y = rand(2,1,3)`. This array has a singleton column dimension — that is, there's only one column per page.

`Y =`

```
Y(:,:,1) = Y(:,:,2) =
 0.5194 0.0346
 0.8310 0.0535
```

```
Y(:,:,3) =
 0.5297
 0.6711
```

The command `Z = squeeze(Y)` yields a 2-by-3 matrix:

```
Z =
 0.5194 0.0346 0.5297
 0.8310 0.0535 0.6711
```

Consider the 1-by-1-by-5 array `mat= repmat(1,[1,1,5])`. This array has only one scalar value per page.

`mat =`

```
mat(:,:,1) = mat(:,:,2) =
 1 1
```



```
mat(:,:,3) = mat(:,:,4) =
 1 1
```

```
mat(:,:,5) =
 1
```

The command `squeeze(mat)` yields a 5-by-1 matrix:

```
squeeze(mat)
```

```
ans =
```

```
 1
 1
 1
 1
 1
```

```
size(squeeze(mat))
```

```
ans =
```

```
 5 1
```

## See Also

[reshape](#) | [shiftdim](#)

**Purpose** Convert state-space filter parameters to transfer function form

**Syntax** `[b,a] = ss2tf(A,B,C,D,iu)`

**Description** `ss2tf` converts a state-space representation of a given system to an equivalent transfer function representation.

`[b,a] = ss2tf(A,B,C,D,iu)` returns the transfer function

$$H(s) = \frac{B(s)}{A(s)} = C(sI - A)^{-1}B + D$$

of the system

$$\dot{x} = Ax + Bu$$

$$y = Cx + Du$$

from the `iu`-th input. Vector `a` contains the coefficients of the denominator in descending powers of  $s$ . The numerator coefficients are returned in array `b` with as many rows as there are outputs  $y$ . `ss2tf` also works with systems in discrete time, in which case it returns the  $z$ -transform representation.

The `ss2tf` function is part of the standard MATLAB language.

## Purpose

Read formatted data from string

## Syntax

```
A = sscanf(str, format)
A = sscanf(str, format, sizeA)
[A, count] = sscanf(...)
[A, count, errmsg] = sscanf(...)
[A, count, errmsg, nextindex] = sscanf(...)
```

## Description

`A = sscanf(str, format)` reads data from string `str`, converts it according to the `format`, and returns the results in array `A`. The `sscanf` function reapplies the `format` until either reaching the end of `str` or failing to match the `format`. If `sscanf` cannot match the `format` to the data, it reads only the portion that matches into `A` and stops processing. If `str` is a character array with more than one row, `sscanf` reads the characters in column order.

`A = sscanf(str, format, sizeA)` reads `sizeA` elements into `A`, where `sizeA` can be an integer or can have the form `[m,n]`.

`[A, count] = sscanf(...)` returns the number of elements that `sscanf` successfully reads.

`[A, count, errmsg] = sscanf(...)` returns an error message string when the operation is unsuccessful. Otherwise, `errmsg` is an empty string.

`[A, count, errmsg, nextindex] = sscanf(...)` returns one more than the number of characters scanned in `str`.

## Tips

- Format specifiers for the reading functions `sscanf` and `fscanf` differ from the formats for the writing functions `sprintf` and `fprintf`. The reading functions do not support a precision field. The width field specifies a minimum for writing but a maximum for reading.

## Input Arguments

### format

String enclosed in single quotation marks that describes each type of element (field). Includes one or more of the following specifiers.

Field Type	Specifier	Details
Integer, signed	%d	Base 10
	%i	Base determined from the values. Defaults to base 10. If initial digits are 0x or 0X, it is base 16. If initial digit is 0, it is base 8.
	%ld or %li	64-bit values, base 10, 8, or 16
Integer, unsigned	%u	Base 10
	%o	Base 8 (octal)
	%x	Base 16 (hexadecimal)
	%lu, %lo, %lx	64-bit values, base 10, 8, or 16
Floating-point number	%f	Floating-point fields can contain any of the following (not case sensitive): Inf, -Inf, NaN, or -NaN.
	%e	
	%g	
Character string	%s	Read series of characters, until find white space.
	%c	Read any single character, including white space. (To read multiple characters, specify field length.)
	%[...]	Read only characters in the brackets, until the first nonmatching character or white space.

Optionally:

- To skip fields, insert an asterisk (\*) after the percent sign (%). For example, to skip integers, specify %\*d.

- To specify the maximum width of a field, insert a number. For example, %10c reads exactly 10 characters at a time, including white space.
- To skip a specific set of characters, insert the literal characters in the *format*. For example, to read only the floating-point number from 'pi=3.14159', specify a *format* of 'pi=%f'.

**sizeA**

Dimensions of the output array *A*. Specify in one of the following forms:

- inf            Read to the end of the input string. (default)
- n*             Read at most *n* elements.
- [*m*,*n*]        Read at most *m*\**n* elements in column order. *n* can be inf, but *m* cannot.

When the *format* includes %s, *A* can contain more than *n* columns. *n* refers to elements, not characters.

**str**

Character string.

**Output Arguments**

**A**

An array. If the *format* includes:

- Only numeric specifiers, *A* is numeric. If *format* includes only 64-bit signed integer specifiers, *A* is of class int64. Similarly, if *format* includes only 64-bit unsigned integer specifiers, *A* is of class uint64. Otherwise, *A* is of class double. If *sizeA* is inf or *n*, then *A* is a column vector. If the input contains fewer than *sizeA* elements, MATLAB pads *A* with zeros.
- Only character or string specifiers (%c or %s), *A* is a character array. If *sizeA* is inf or *n*, *A* is a row vector. If the input contains fewer than *sizeA* characters, MATLAB pads *A* with char(0).

- A combination of numeric and character specifiers, *A* is numeric, of class `double`. MATLAB converts each character to its numeric equivalent. This conversion occurs even when the *format* explicitly skips all numeric values (for example, a *format* of `'%*d %s'`).

If MATLAB cannot match the input to the *format*, and the *format* contains both numeric and character specifiers, *A* can be numeric or character. The class of *A* depends on the values MATLAB reads before processing stops.

## **count**

Number of elements `sscanf` reads into *A*.

## **errmsg**

An error message string when `sscanf` cannot open the specified file. Otherwise, an empty string.

## **nextindex**

`sscanf` counts the number of characters `sscanf` reads from *str*, and then adds one.

## **Examples**

### **Example 1**

Read multiple floating-point values from a string:

```
s = '2.7183 3.1416';
A = sscanf(s, '%f ');
A =
 2.7183
 3.1416
```

### **Example 2**

Read an octal integer from a string, identified by the `'0'` prefix, using `%i` to preserve the sign:

```
sscanf('-010', '%i')
ans =
```

-8

### Example 3

Read numeric values from a two-dimensional character array. By default, `sscanf` reads characters in column order. To preserve the original order of the values, read one row at a time.

```
mixed = ['abc 45 6 ghi'; 'def 7 89 jkl'];

[nrows, ncols] = size(mixed);
for k = 1:nrows
 nums(k,:) = sscanf(mixed(k,:), '%*s %d %d %*s', [1, inf]);
end;

% type the variable name to see the result
nums =
 45 6
 7 89
```

### Example 4

`sscanf` finds one match for `%s`

```
[str count] = sscanf('ThisIsOneString', '%s')
str =
 ThisIsOneString
count =
 1
```

`sscanf` finds four matches for `%s`. Because it does not match space characters, there are no spaces in the output string:

```
[str count] = sscanf('These Are Four Strings', '%s')
str =
 TheseAreFourStrings
count =
 4
```

sscanf finds five word matches for %s and four space character matches for %c. Because the %c specifier does match a space character, the output string does include spaces:

```
[str count] = sscanf('Five strings and four spaces', '%s%c')
str =
 Five strings and four spaces
count =
 9
```

sscanf finds three word matches for %s and two numeric matches for %d. Because the format specifier has a mixed %d and %s format, sscanf converts all nonnumeric characters to numeric:

```
[str count] = sscanf('5 strings and 4 spaces', '%d%s%s%d%s');
str'
Columns 1 through 9
 5 115 116 114 105 110 103 115 97
Columns 10 through 18
 110 100 4 115 112 97 99 101 115
count
count =
 5
```

## Example 5

```
[str, count] = sscanf('one two three', '%c')
str =
 one two three
count =
 13
```

```
[str, count] = sscanf('one two three', '%13c')
str =
 one two three
count =
 1
```



```
[str, count] = sscanf('one two three', '%s')
str =
 onetwothree
count =
 3
```

```
[str, count] = sscanf('one two three', '%1s')
str =
 onetwothree
count =
 11
```

### Example 6

```
tempString = '78 F 72 F 64 F 66 F 49 F';

degrees = char(176);
tempNumeric = sscanf(tempString, ['%d' degrees 'F'])'
tempNumeric =
 78 72 64 66 49
```

### See Also

fscanf | sprintf | textscan

# stack

---

**Purpose** Stack data from multiple variables into single variable

**Syntax**

```
T = stack(W,vars)
T = stack(W,vars,Name,Value)
[T,iw] = stack(___)
```

**Description** `T = stack(W,vars)` converts the wide table, `W`, into an equivalent table, `T`, that is in tall format. `stack` stacks up multiple variables from `W`, specified by `vars`, into a single variable in `T`. In general, `T` contains fewer variables, but more rows, than `W`.

The output table, `T`, contains a new categorical variable to indicate which variable in `W` the stacked data in each row came from. `stack` replicates data from the variables in `W` that are not stacked.

`T = stack(W,vars,Name,Value)` converts the table, `W`, to tall format with additional options specified by one or more `NAME,Value` pair arguments.

For example, you can specify variable names for the new and stacked variables in `W`.

`[T,iw] = stack( ___ )` also returns an index vector, `iw`, indicating the correspondence between rows in `T` and rows in `W`. You can use any of the previous input arguments.

## Input Arguments

### **W - Wide table**

table

Wide table, specified as a table.

### **vars - Variables in W to stack**

positive integer | vector of positive integers | variable name | cell array of variable names | logical vector

Variables in `W` to stack, specified as a positive integer, vector of positive integers, variable name, cell array of variable names, or logical vector.

## **Name-Value Pair Arguments**

Specify optional comma-separated pairs of `Name`, `Value` arguments. `Name` is the argument name and `Value` is the corresponding value. `Name` must appear inside single quotes ( ' '). You can specify several name and value pair arguments in any order as `Name1, Value1, ..., NameN, ValueN`.

**Example:** `'NewDataVariableName', 'StackedData'` names the new data variable `StackedData`.

## **'ConstantVariables' - Variables other than vars to include in the output**

positive integer | vector of positive integers | variable name | cell array of variable names | logical vector

Variables other than `vars` to include in the output, specified as the comma-separated pair consisting of `'ConstantVariables'` and a positive integer, vector of positive integers, variable name, cell array of variable names, or logical vector. `stack` replicates the data from the constant variables for each stacked entry from a row.

The default is all the variables in `W` not specified by `vars`. You can specify the `'ConstantVariables'` name-value pair argument to exclude variables not specified by `vars` or `'ConstantVariables'` from the output table, `T`.

## **'NewDataVariableName' - Name for the new data variable in T** string

Name for the new data variable in `T`, specified as the comma-separated pair consisting of `'NewDataVariableName'` and a string. The default is a concatenation of the names of the variables from `W` that are stacked up.

## **'IndexVariableName' - Name for the new indicator variable in T** string

Name for the new indicator variable in `T`, specified as the comma-separated pair consisting of `'IndexVariableName'` and a string. The default is a name based on `NewDataVariableName`.

## Output Arguments

### T - Tall table

table

Tall table, returned as a table. T contains a stacked data variable, a categorical indicator variable, and any constant variables.

You can store additional metadata such as descriptions, variable units, variable names, and row names in the table. For more information, see [Table Properties](#).

`stack` assigns the variable units and variable description property values from the first variable listed in `vars` to the corresponding `T.Properties.VariableUnits` and `T.Properties.VariableDescriptions` values for the new data variable.

### iw - Index to W

column vector

Index to W, returned as a column vector. The index vector, `iw`, identifies the row in the input table, W, containing the corresponding data. `stack` creates the `j`th row in the output table, T, using `W(iw(j), vars)`.

## Examples

### Stack Three Variables into One

Create a table containing test scores from three separate tests.

```
Test1 = [93;57;87;89];
```

```
Test2 = [89;77;92;86];
```

```
Test3 = [95;62;89;91];
```

```
W = table(Test1,Test2,Test3)
```

```
W =
```

Test1	Test2	Test3
93	89	95

```

57 77 62
87 92 89
89 86 91

```

The table contains four rows and three variables.

Stack the test scores into a single variable.

```
T = stack(W,1:3)
```

```
T =
```

Test1_Test2_Test3_Indicator	Test1_Test2_Test3
Test1	93
Test2	89
Test3	95
Test1	57
Test2	77
Test3	62
Test1	87
Test2	92
Test3	89
Test1	89
Test2	86
Test3	91

T contains twelve rows and two variables.

The categorical variable, Test1\_Test2\_Test3\_Indicator, identifies which test corresponds to the score in the stacked data variable, Test1\_Test2\_Test3.

### Stack Variables and Specify Variable Names

Create a table indicating the amount of snowfall at three locations from five separate storms.

```
Storm = [1;2;3;4;5];
Date = {'12/25/11';'1/2/12';'1/23/12';'2/7/12';'2/15/12'};
Natick = [20;5;13;0;17];
Boston = [18;9;21;5;12];
Worcester = [26;10;16;3;15];
```

```
W = table(Storm,Date,Natick,Boston,Worcester)
```

```
W =
```

Storm	Date	Natick	Boston	Worcester
1	'12/25/11'	20	18	26
2	'1/2/12'	5	9	10
3	'1/23/12'	13	21	16
4	'2/7/12'	0	5	3
5	'2/15/12'	17	12	15

The variables `Storm` and `Date` contain data that is constant at each location.

Stack the variables `Natick`, `Boston`, and `Worcester` into a single variable. Name the variable containing the stacked data, `Snowfall`, and name the new indicator variable, `Town`.

```
T = stack(W,{'Natick','Boston','Worcester'},...
 'NewDataVariableName','Snowfall',...
 'IndexVariableName','Town')
```

```
T =
```

Storm	Date	Town	Snowfall
1	'12/25/11'	Natick	20
1	'12/25/11'	Boston	18
1	'12/25/11'	Worcester	26

```

2 '1/2/12' Natick 5
2 '1/2/12' Boston 9
2 '1/2/12' Worcester 10
3 '1/23/12' Natick 13
3 '1/23/12' Boston 21
3 '1/23/12' Worcester 16
4 '2/7/12' Natick 0
4 '2/7/12' Boston 5
4 '2/7/12' Worcester 3
5 '2/15/12' Natick 17
5 '2/15/12' Boston 12
5 '2/15/12' Worcester 15

```

T contains three rows for each storm, and `stack` repeats the data in the constant variables, `Storm` and `Date`, accordingly.

The categorical variable, `Town`, identifies which variable in `W` contains the corresponding `Snowfall` data.

### Stack Variables and Output an Index Vector

Create a table containing estimated influenza rates along the east coast of the United States. Create a different variable for the Northeast, Mid Atlantic, and South Atlantic. Data Source: Google Flu Trends (<http://www.google.org/flutrends>).

```

Month = {'October'; 'November'; 'December'; ...
 'January'; 'February'; 'March'};
Year = [2005*ones(3,1); 2006*ones(3,1)];
NE = [1.1902; 1.3610; 1.5003; 1.7772; 2.1350; 2.2345];
MidAtl = [1.1865; 1.4120; 1.6043; 1.8830; 2.1227; 1.9920];
SAtl = [1.2730; 1.5820; 1.8625; 1.9540; 2.4803; 2.0203];

```

```
fluW = table(Month,Year,NE,MidAtl,SAtl)
```

```
fluW =
```

```

 Month Year NE MidAtl SAtl

```

'October'	2005	1.1902	1.1865	1.273
'November'	2005	1.361	1.412	1.582
'December'	2005	1.5003	1.6043	1.8625
'January'	2006	1.7772	1.883	1.954
'February'	2006	2.135	2.1227	2.4803
'March'	2006	2.2345	1.992	2.0203

The variables `Month` and `Year` contain data that is constant across the row.

Stack the variables `NE`, `MidAtl`, and `SAtl` into a single variable called `FluRate`. Name the new indicator variable `Region` and output an index vector, `ifluW`, to indicate the correspondence between rows in the input wide table, `fluW`, and the output tall table, `fluT`.

```
[fluT,ifluW] = stack(fluW,3:5,...
 'NewDataVariableName','FluRate',...
 'IndexVariableName','Region')
```

`fluT =`

Month	Year	Region	FluRate
'October'	2005	NE	1.1902
'October'	2005	MidAtl	1.1865
'October'	2005	SAtl	1.273
'November'	2005	NE	1.361
'November'	2005	MidAtl	1.412
'November'	2005	SAtl	1.582
'December'	2005	NE	1.5003
'December'	2005	MidAtl	1.6043
'December'	2005	SAtl	1.8625
'January'	2006	NE	1.7772
'January'	2006	MidAtl	1.883
'January'	2006	SAtl	1.954



'February'	2006	NE	2.135
'February'	2006	MidAtl	2.1227
'February'	2006	SAtl	2.4803
'March'	2006	NE	2.2345
'March'	2006	MidAtl	1.992
'March'	2006	SAtl	2.0203

```
ifluW =
```

```

1
1
1
2
2
2
3
3
3
4
4
4
5
5
5
6
6
6
```

`ifluW(5)` is 2. The fifth row in the output table, `fluT`, contains data from the second row in the input table `fluW`.

## Tips

- You can specify more than one group of data variables in `W`, and each group becomes a stacked data variable in `T`. Use a cell array to contain multiple values for `vars`, and a cell array of strings to contain multiple values for the `'NewDataVariableName'` name-value pair argument. All groups must contain the same number of variables.

# stack

---

## See Also

[unstack](#) | [join](#)

**Purpose**

Stairstep graph

**Syntax**

```
stairs(Y)
stairs(X,Y)
stairs(____,LineStyleSpec)
stairs(____,Name,Value)

stairs(axes_handle, ____)

h = stairs(____)

[xb,yb] = stairs(____)
```

**Description**

`stairs(Y)` draws a stairstep graph of the elements in `Y`.

- If `Y` is a vector, then the `x`-axis scale ranges from 1 to `length(Y)`.
- If `Y` is a matrix, then `stairs` draws one line per matrix column and the `x`-axis scale ranges from 1 to the number of rows in `Y`.

`stairs(X,Y)` plots the elements in `Y` at the locations specified in `X`. The inputs `X` and `Y` must be vectors or matrices of the same size. Additionally, `X` can be a row or column vector and `Y` must be a matrix with `length(X)` rows.

`stairs( ____,LineStyleSpec)` specifies a line style, marker symbol, and color. Use this option with any of the input argument combinations in the previous syntaxes.

`stairs( ____,Name,Value)` specifies stairseries properties using one or more `Name,Value` pair arguments.

`stairs(axes_handle, ____)` plots into the axes specified by `axes_handle` instead of into the current axes (`gca`). The option, `axes_handle`, can precede any of the input argument combinations in the previous syntaxes.

# stairs

---

`h = stairs( ___ )` returns a vector of stairseries object handles in `h`. When multiple stairseries are present, you can make changes to properties of a specific stairseries by specifying a particular handle.

`[xb,yb] = stairs( ___ )` does not create a plot, but returns matrices `xb` and `yb` of the same size, such that `plot(xb,yb)` plots the staircase graph.

## Input Arguments

### Y - Elements to plot

vector or matrix

Elements to plot, specified as a vector or matrix. When `Y` is a vector, `stairs` creates one stairseries. When `Y` is a matrix, `stairs` draws one line per matrix column and creates a separate stairseries for each column.

### Data Types

single | double | int8 | int16 | int32 | int64 | uint8 |  
uint16 | uint32 | uint64 | logical

### X - Locations to plot elements in Y

vector or matrix

Locations to plot elements in `Y`, specified as a vector or matrix. When `Y` is a vector, `X` must be a vector of the same size. When `Y` is a matrix, `X` must be a matrix of the same size, or a vector whose length equals the number of rows in `Y`.

### Data Types

single | double | int8 | int16 | int32 | int64 | uint8 |  
uint16 | uint32 | uint64 | logical

### LineStyle - Line style, marker symbol, and color

string

Line style, marker symbol, and color, specified as a string. For more information on line style, marker symbol, and color options see `LineStyle`.

**Example:** `':*r'`

### Data Types

char

### axes\_handle - Axes handle

handle

Axes handle, which is the reference to an axes object. Use the `gca` function to get the handle to the current axes, for example, `axes_handle = gca;`

### Name-Value Pair Arguments

Specify optional comma-separated pairs of `Name`, `Value` arguments. `Name` is the argument name and `Value` is the corresponding value. `Name` must appear inside single quotes ( `' '` ). You can specify several name and value pair arguments in any order as `Name1,Value1,...,NameN,ValueN`.

**Example:** `'Marker','s','MarkerFaceColor','red'` plots the stairstep graph with red square markers.

For more information on `stairs` properties see `stairs`.

### 'LineStyle' - Line style

`'-'` (default) | `'--'` | `':'` | `'-.'` | `'none'`

Line style, specified as the comma-separated pair consisting of `'LineStyle'` and a line style specifier. This table lists supported line styles.

Specifier	Line Style
<code>'-'</code>	Solid line (default)
<code>'--'</code>	Dashed line
<code>':'</code>	Dotted line

Specifier	Line Style
'- . '	Dash-dot line
'none'	No line

**Example:** 'LineStyle', '- . '

### 'LineWidth' - Line width

0.5 (default) | scalar

Line width, specified as the comma-separated pair consisting of 'LineWidth' and a scalar in points.

**Example:** 'LineWidth',0.75

### 'Color' - Color

[0 0 1] (blue) (default) | three-element RGB vector | string

Color, specified as the comma-separated pair consisting of 'Color' and a three-element RGB vector or a string containing the short or long name of the color. The RGB vector is a three-element row vector whose elements specify the intensities of the red, green, and blue components of the color. The intensities must be in the range [0 1].

This table lists the predefined colors and their RGB equivalents.

RGB Vector	Short Name	Long Name
[1 1 0]	'y'	'yellow'
[1 0 1]	'm'	'magenta'
[0 1 1]	'c'	'cyan'
[1 0 0]	'r'	'red'
[0 1 0]	'g'	'green'
[0 0 1]	'b'	'blue'
[1 1 1]	'w'	'white'
[0 0 0]	'k'	'black'

**Example:** 'Color', [0 1 0]

**Example:** 'Color', 'green'

**Example:** 'Color', 'g'

### 'Marker' - Marker symbol

'none' (default) | string

Marker symbol, specified as the comma-separated pair consisting of 'Marker' and a marker specifier. This table lists supported marker symbols.

Specifier	Marker Symbol
'o'	Circle
'+'	Plus sign
'*'	Asterisk
'.'	Point
'x'	Cross
'square' or 's'	Square
'diamond' or 'd'	Diamond
'^'	Upward-pointing triangle
'v'	Downward-pointing triangle
'>'	Right-pointing triangle
'<'	Left-pointing triangle
'pentagram' or 'p'	Five-pointed star (pentagram)
'hexagram' or 'h'	Six-pointed star (hexagram)
'none'	No marker

**Example:** 'Marker', '+'

**Example:** 'Marker', 'diamond'

## 'MarkerEdgeColor' - Marker edge color

'auto' (default) | 'none' | three-element RGB vector | string

Marker edge color, specified as the comma-separated pair consisting of 'MarkerEdgeColor' and a color value. The color value can be one of the supported strings or an RGB vector, listed in the following tables.

Specifier	Result
'auto'	Uses same color as line color
'none'	Specifies no color, which makes unfilled markers invisible

For an RGB vector, use a three-element row vector whose elements specify the intensities of the red, green, and blue components of the color. The intensities must be in the range [0 1]. This table lists the predefined string colors and their RGB equivalents.

RGB Vector	Short Name	Long Name
[1 1 0]	'y'	'yellow'
[1 0 1]	'm'	'magenta'
[0 1 1]	'c'	'cyan'
[1 0 0]	'r'	'red'
[0 1 0]	'g'	'green'
[0 0 1]	'b'	'blue'
[1 1 1]	'w'	'white'
[0 0 0]	'k'	'black'

**Example:** 'MarkerEdgeColor',[1 .8 .1]

## 'MarkerFaceColor' - Marker face color

'none' (default) | 'auto' | three-element RGB vector | string



Marker face color, specified as the comma-separated pair consisting of 'MarkerFaceColor' and a color value. MarkerFaceColor sets the fill color for markers that are closed shapes (circle, square, diamond, pentagram, hexagram, and the four triangles). The color value can be one of the supported strings or an RGB vector, listed in the following tables.

Specifier	Result
'auto'	Uses same color as marker edge color
'none'	Makes the interior of the marker transparent, allowing the background to show through (default)

For an RGB vector, use a three-element row vector whose elements specify the intensities of the red, green, and blue components of the color. The intensities must be in the range [0 1]. This table lists the predefined string colors and their RGB equivalents.

RGB Vector	Short Name	Long Name
[1 1 0]	'y'	'yellow'
[1 0 1]	'm'	'magenta'
[0 1 1]	'c'	'cyan'
[1 0 0]	'r'	'red'
[0 1 0]	'g'	'green'
[0 0 1]	'b'	'blue'
[1 1 1]	'w'	'white'
[0 0 0]	'k'	'black'

Example: 'MarkerFaceColor',[0 .8 1]

### 'MarkerSize' - Marker size

# stairs

---

6 (default) | scalar

Marker size, specified as the comma-separated pair consisting of 'MarkerSize' and a scalar in points.

**Example:** 'MarkerSize',7

## Output Arguments

### **h - Stairseries object handle**

scalar or column vector

Stairseries object handle, specified as a scalar or column vector. This is a unique identifier, which you can use to query and modify the properties of a specific `stairs`.

### **xb - x values for use with plot**

vector or matrix

`x` values for use with `plot`, specified as a vector or matrix. `xb` contains the appropriate values such that `plot(xb,yb)` creates the staircase graph.

### **yb - y values for use with plot**

vector or matrix

`y` values for use with `plot`, specified as a vector or matrix. `yb` contains the appropriate values such that `plot(xb,yb)` creates the staircase graph.

## Examples

### **Plot Single Data Series**

Create a staircase plot of sine evaluated at 40 equally spaced values between 0 and  $4\pi$ .

```
X = linspace(0,4*pi,40);
Y = sin(X);
```

```
figure
stairs(Y)
```

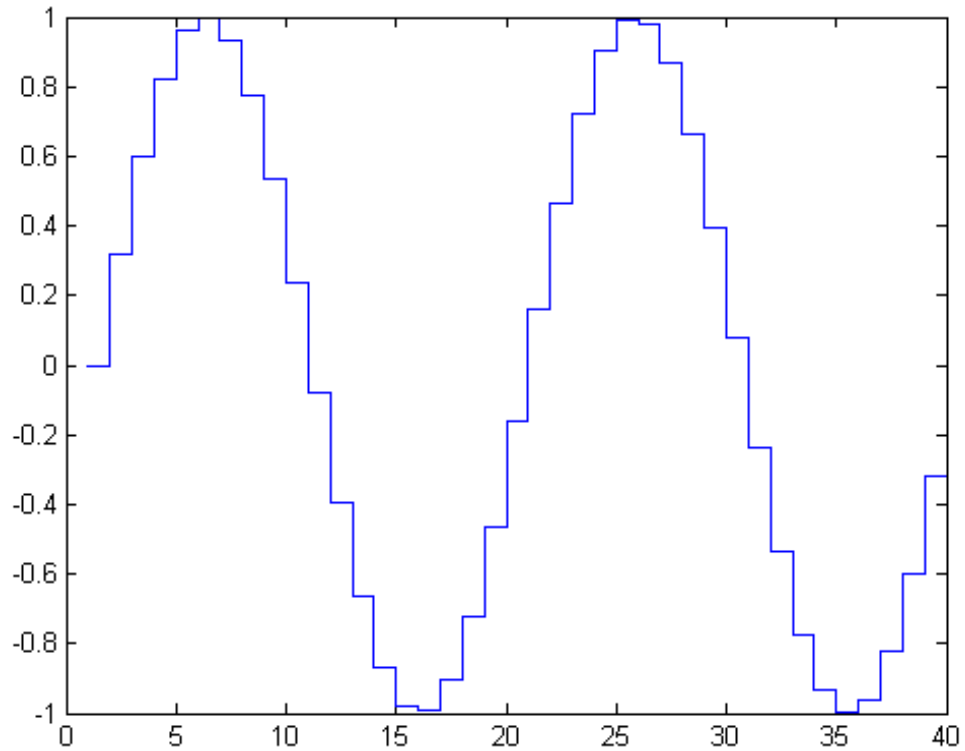

The length of  $Y$  automatically determines and generates the  $x$ -axis scale.

### Plot Multiple Data Series

Create a staircase plot of two cosine functions evaluated at 50 equally spaced values between 0 and  $4\pi$ .

```
X = linspace(0,4*pi,50)';
Y = [0.5*cos(X), 2*cos(X)];
```

```
figure
```

# stairs

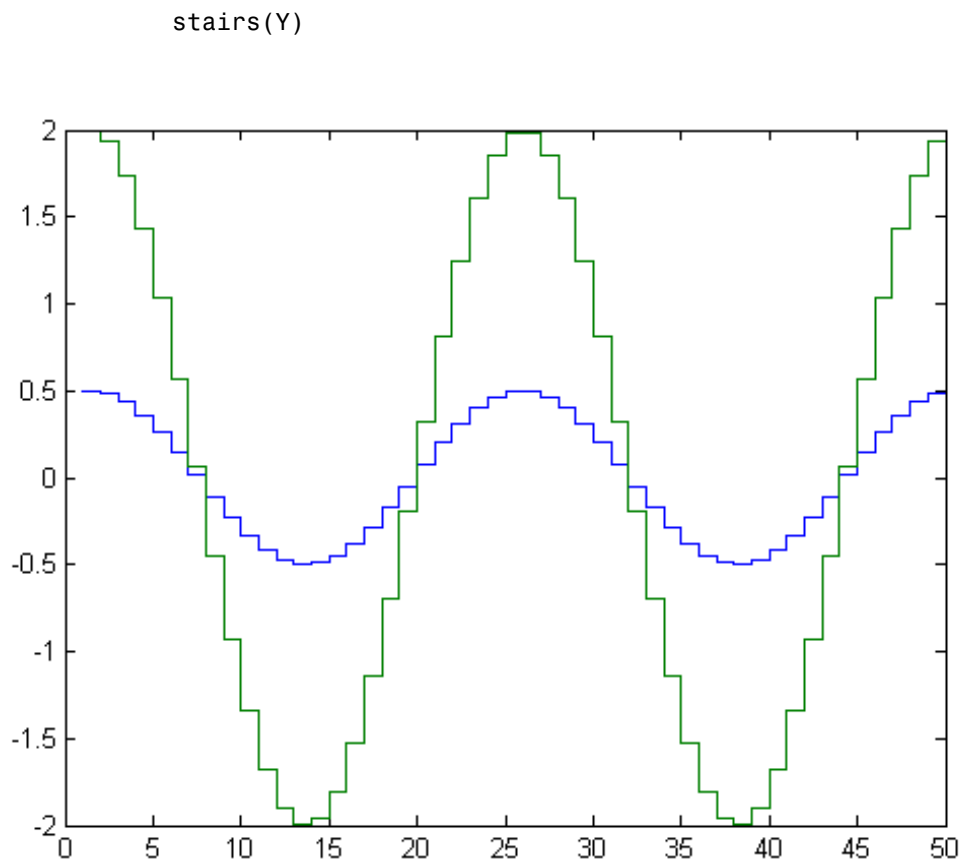

The number of rows in  $Y$  automatically determines and generates the  $x$ -axis scale.

## Plot Single Data Series at Specified $x$ -Values

Create a staircase plot of a sine wave evaluated at equally spaced values between 0 and  $4\pi$ . Specify the set of  $x$ -values for the plot.

```
X = linspace(0,4*pi,40);
```

```
Y = sin(X);

figure
stairs(X,Y)
```

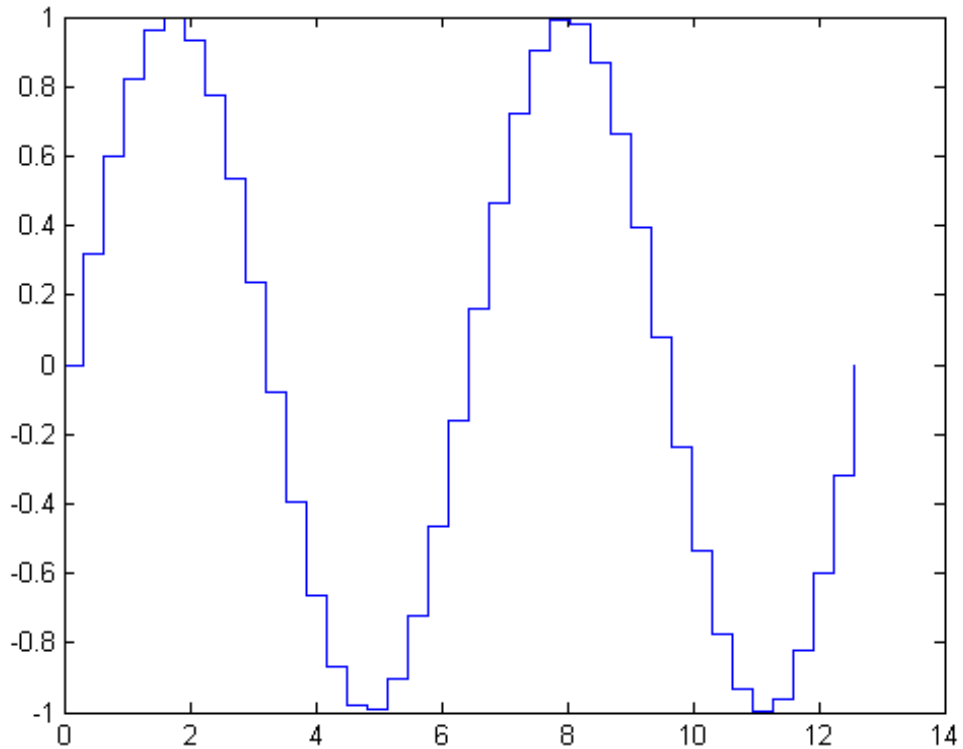

The entries in  $Y$  are plotted against the corresponding entries in  $X$ .

### Plot Multiple Data Series at Specified x-Values

Create a staircase plot of two cosine waves evaluated at equally spaced values between 0 and  $4\pi$ . Specify the set of  $x$ -values for the plot.

# stairs

---

```
X = linspace(0,4*pi,50)';
Y = [0.5*cos(X), 2*cos(X)];
```

```
figure
stairs(X,Y)
```

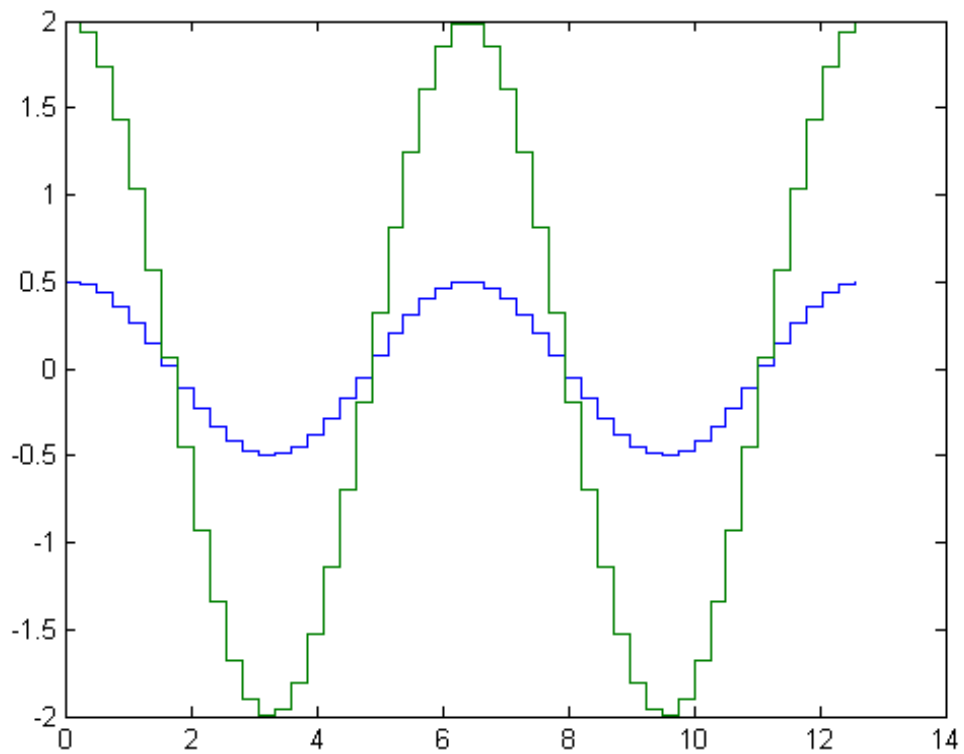

The first vector input,  $X$ , determines the  $x$ -axis positions for both data series.

### Plot Multiple Data Series at Unique Sets of x-Values

Create a staircase plot of two sine waves evaluated at different values. Specify a unique set of  $x$ -values for plotting each data series.

```
x1 = linspace(0,2*pi)';
x2 = linspace(0,pi)';
X = [x1,x2];
Y = [sin(5*x1),exp(x2).*sin(5*x2)];
```

```
figure
stairs(X,Y)
```

# stairs

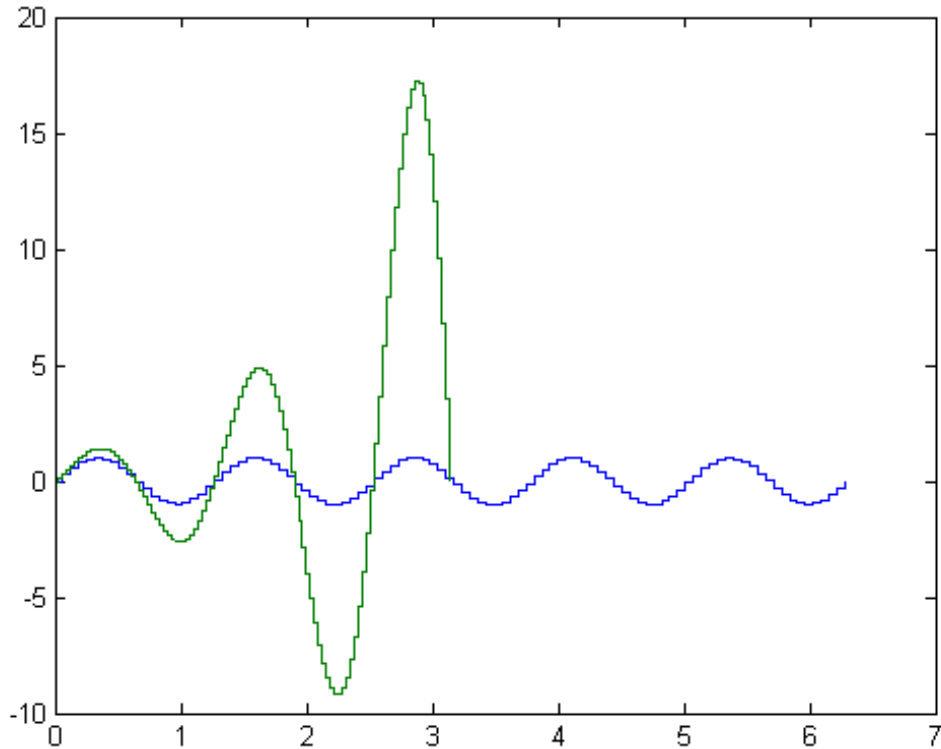

Each column of X is plotted against the corresponding column of Y.

## **Specify Line Style, Marker Symbol and Color**

Create a staircase plot and set the line style to a dot-dashed line, the marker symbol to circles, and the color to red.

```
X = linspace(0,4*pi,20);
Y = sin(X);
```

```
figure
```



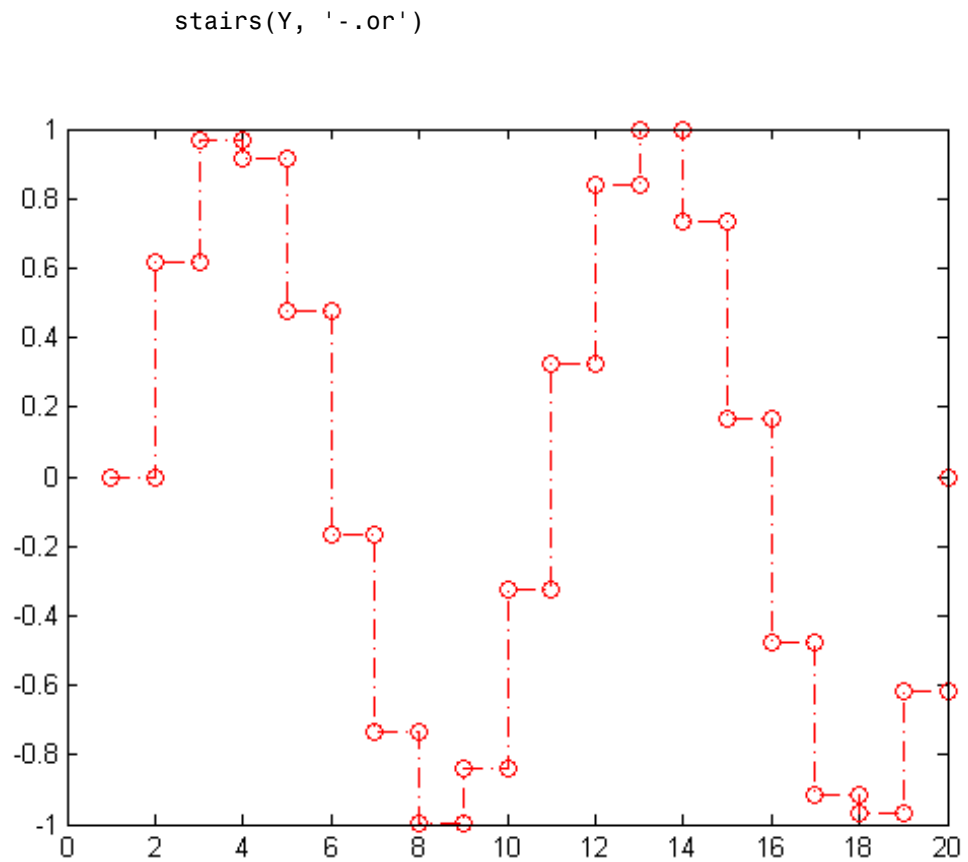

**Specify Additional Style Options**

Create a staircase plot and set the line width to 2, the marker symbols to diamonds, and the marker face color to cyan using Name, Value pair arguments.

```
X = linspace(0,4*pi,20);
Y = sin(X);
```

# stairs

```
figure
stairs(Y,'LineWidth',2,'Marker','d','MarkerFaceColor','c')
```

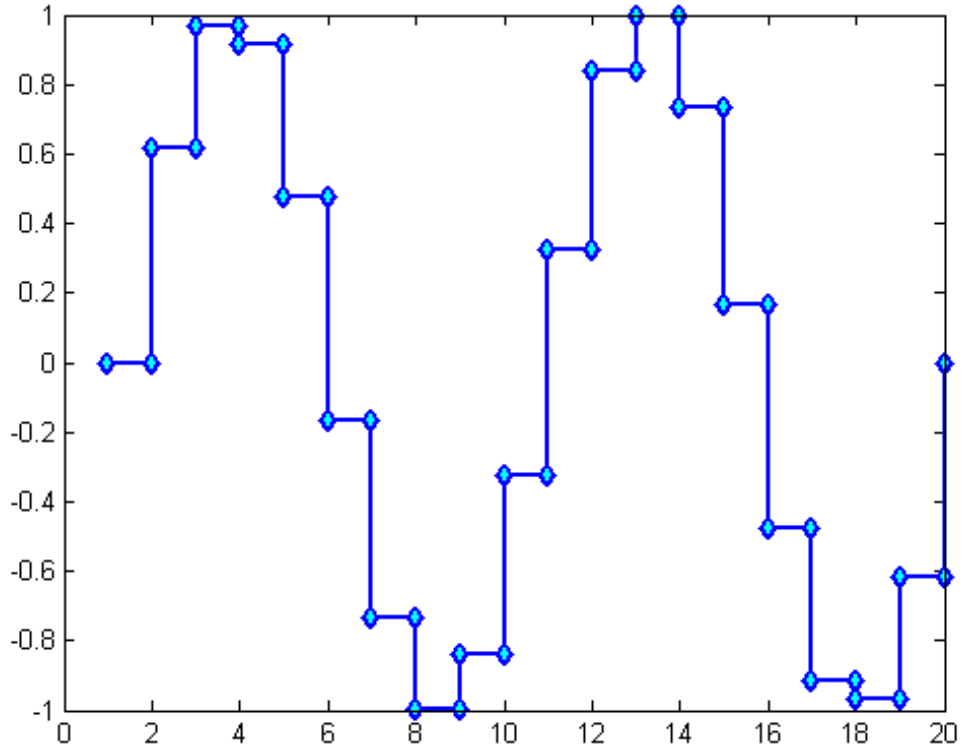

## Specify Axes for Stairstep Plots

Create a figure with two subplots and return the two axes handles, `s(1)` and `s(2)`. Create a stairstep plot in each subplot by referring to the axes handles.

```
figure
s(1) = subplot(2,1,1);
s(2) = subplot(2,1,2);

X = linspace(0,2*pi);
Y1 = 5*sin(X);
Y2 = sin(5*X);
stairs(s(1),X,Y1)
stairs(s(2),X,Y2)
```

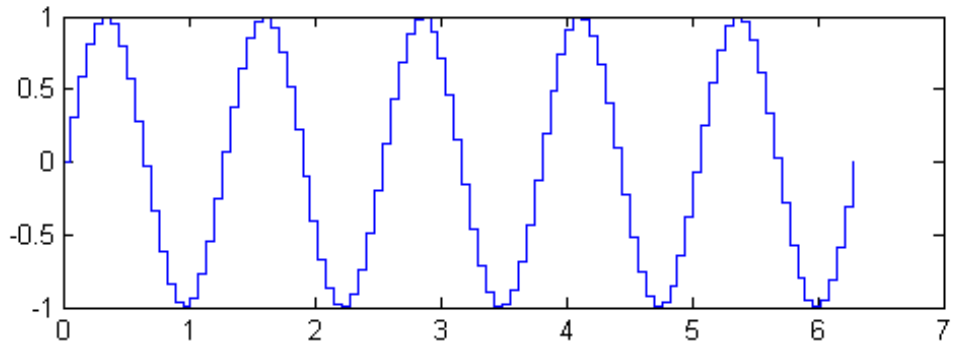
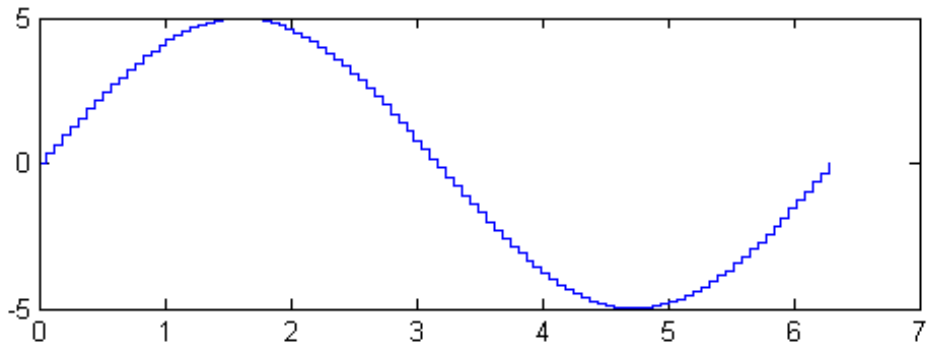

## Set Marker Properties Using Stairseries Handle

Create a staircase plot of two data series and return the two stairseries handles in array h.

```
X = linspace(0,1,30)';
Y = [cos(10*X), exp(X).*sin(10*X)];
```

```
figure
h = stairs(X,Y);
```

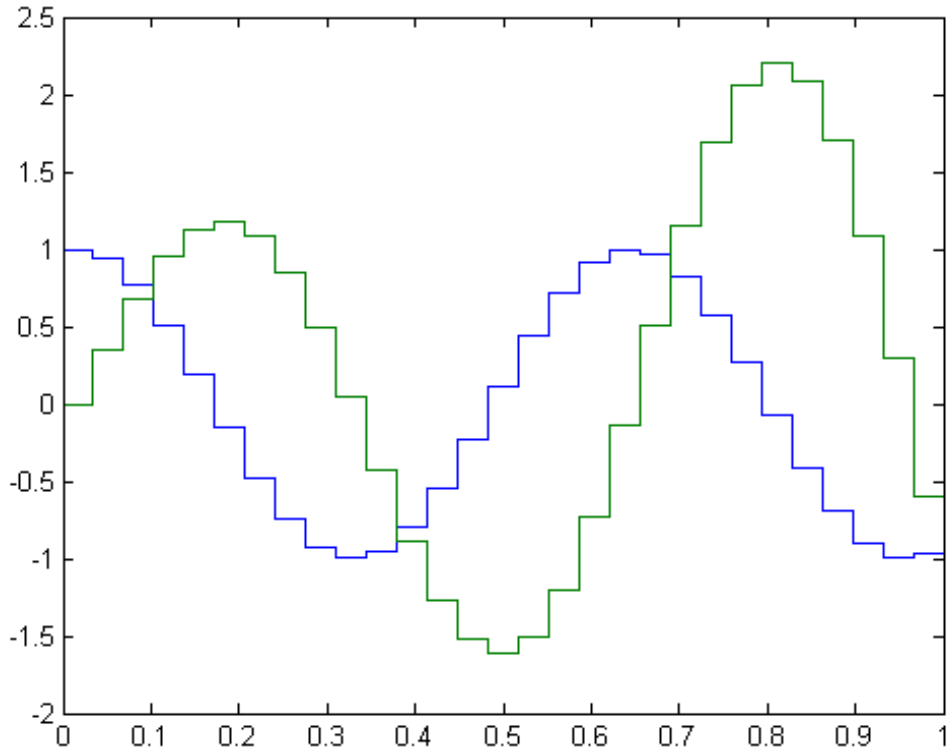

Set the markers of the first series to small circles and the second series to magenta filled circles by referring to the handles.

```
set(h(1), 'Marker', 'o', 'MarkerSize', 4)
set(h(2), 'Marker', 'o', 'MarkerFaceColor', 'm')
```

# stairs

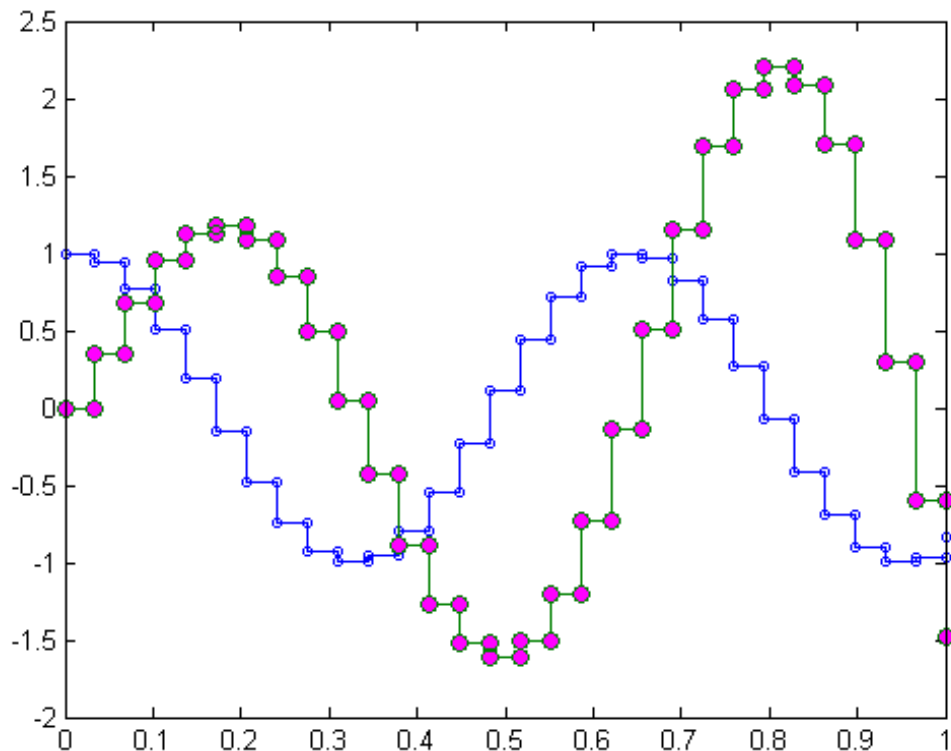

## Create a Stairstep Plot using plot Function

Evaluate two cosine functions at 50 equally spaced values between 0 and  $4\pi$  and create a stairstep plot using plot.

```
X = linspace(0,4*pi,50)';
Y = [0.5*cos(X), 2*cos(X)];
[xb,yb] = stairs(X,Y);
```

`stairs` returns two matrices of the same size, `xb` and `yb`, but no plot.

Use plot to create the staircase plot with xb and yb.

```
figure
plot(xb,yb)
```

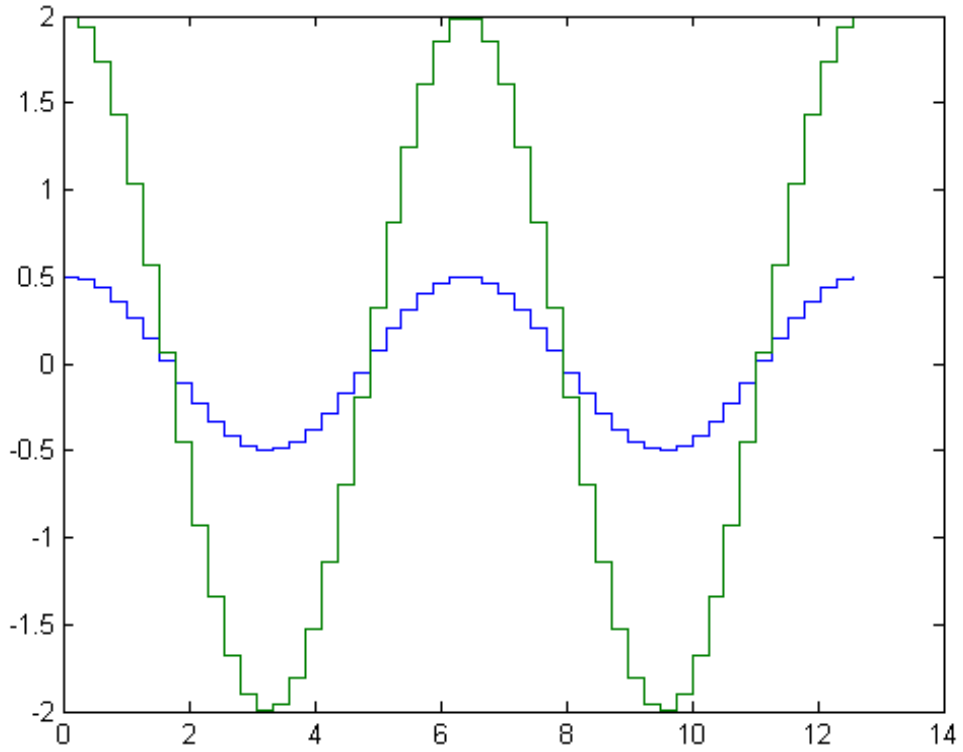

**See Also**

[bar](#) | [hist](#) | [stem](#) | [LineSpec](#) | [Stairseries](#) |

# Stairseries Properties

---

**Purpose** Define stairseries properties

**Modifying Properties** You can set and query graphics object properties using the `set` and `get` commands or the Property Editor (`propertyeditor`).

Note that you cannot define default property values for stairseries objects.

See Plot Objects for information on stairseries objects.

## Stairseries Property Descriptions

This section provides a description of properties. Curly braces { } enclose default values.

Annotation

`hg.Annotation` object (read-only)

*Control the display of stairseries objects in legends.* Specifies whether this stairseries object is represented in a figure legend.

Querying the `Annotation` property returns the handle of an `hg.Annotation` object. The `hg.Annotation` object has a property called `LegendInformation`, which contains an `hg.LegendEntry` object.

Once you have obtained the `hg.LegendEntry` object, you can set its `IconDisplayStyle` property to control whether the stairseries object is displayed in a figure legend.

IconDisplayStyle Value	Purpose
on	Include the stairseries object in a legend as one entry, but not its children objects
off	Do not include the stairseries or its children in a legend (default)
children	Include only the children of the stairseries as separate entries in the legend



## Setting the IconDisplayStyle Property

These commands set the `IconDisplayStyle` of a graphics object with handle `hobj` to `children`, which causes each child object to have an entry in the legend:

```
hAnnotation = get(hobj, 'Annotation');
hLegendEntry = get(hAnnotation, 'LegendInformation');
set(hLegendEntry, 'IconDisplayStyle', 'children')
```

## Using the IconDisplayStyle Property

See “Control Legend Content” for more information and examples.

### BeingDeleted

`on` | `{off}` (read-only)

*This object is being deleted.* Mechanism to determine if objects are in the process of being deleted. MATLAB sets the `BeingDeleted` property to `on` when the object’s delete function callback is called (see the `DeleteFcn` property). It remains set to `on` while the delete function executes, after which the object no longer exists.

For example, an object’s delete function calls other functions that act on a number of different objects. If a function does not need to perform an action on an about-be-deleted object, it can check the object’s `BeingDeleted` property before acting.

### BusyAction

`cancel` | `{queue}`

*Callback queuing*

Determines how MATLAB handles the execution of interrupting callbacks.

A *running* callback is the currently executing callback. The *interrupting* callback is the callback that tries to interrupt the

# Stairseries Properties

---

*running* callback. The `BusyAction` property of the *interrupting* callback determines how MATLAB handles its execution. When the `BusyAction` property is set to:

- 'queue' — Puts the *interrupting* callback in a queue to be processed after the *running* callback finishes execution.
- 'cancel' — Discards the *interrupting* callback as MATLAB finishes execution.

For information about how the `Interruptible` property of the callback controls whether other callbacks can interrupt the *running* callback, see the `Interruptible` property description.

## `ButtonDownFcn`

string | function handle

*Button press callback function.* Executes whenever you press a mouse button while the pointer is over this object, but not over another graphics object. See the `HitTestArea` property for information about selecting objects of this type.

See the figure's `SelectionType` property to determine if modifier keys were also pressed.

This property can be:

- A string that is a valid MATLAB expression
- The name of a MATLAB file
- A function handle

Set this property to a function handle that references the callback. The expressions execute in the MATLAB workspace.

For information on the syntax of callback functions, see [Function Handle Callbacks](#).

The expression executes in the MATLAB workspace.

For information on the syntax of callback functions, see [Function Handle Callbacks](#).

## Children

array of graphics object handles

*Children of the stairseries object.* An array containing the handles of all line objects parented to the stairseries object (whether visible or not).

If a child object's `HandleVisibility` property is `callback` or `off`, its handle does not show up in this object's `Children` property. If you want the handle in the `Children` property, set the root `ShowHiddenHandles` property to `on`. For example:

```
set(0, 'ShowHiddenHandles', 'on')
```

## Clipping

{on} | off

*Clipping mode.* MATLAB clips graphs to the axes plot box by default. If you set `Clipping` to `off`, portions of graphs appear outside the axes plot box. This occurs if you create a plot object, set `hold` to `on`, freeze axis scaling (`axis manual`), and then create a larger plot object.

## Color

ColorSpec

*Color of the object.* A three-element RGB vector or one of the MATLAB predefined names, specifying the object's color. The default value is `[0 0 0]` (black).

See the `ColorSpec` reference page for more information on specifying color. See “Adding Arrows and Lines to Graphs”.

# Stairseries Properties

---

## CreateFcn

function handle | cell array containing function handle and additional arguments | string (not recommended)

*Callback function executed during object creation.* Defines a callback that executes when MATLAB creates an object. The default is an empty array.

You must specify the callback during the creation of the object. For example:

```
graphicfcn(y, 'CreateFcn', @CallbackFcn)
```

where `@CallbackFcn` is a function handle that references the callback function and `graphicfcn` is the plotting function which creates this object.

MATLAB executes this routine after setting all other object properties. Setting this property on an existing object has no effect.

The handle of the object whose `CreateFcn` is being executed is accessible only through the root `CallbackObject` property, which you can query using `gcbo`.

For information on the syntax of callback functions, see [Function Handle Callbacks](#).

## DeleteFcn

function handle | cell array containing function handle and additional arguments | string (not recommended)

*Callback executed during object deletion.* Executes when this object is deleted (for example, this might happen when you issue a `delete` command on the object, its parent axes, or the figure containing it). MATLAB executes the callback before destroying the object's properties so the callback routine can query these values. The default is an empty array.

The handle of the object whose `DeleteFcn` is being executed is accessible only through the root `CallbackObject` property, which can be queried using `gcb0`.

For information on the syntax of callback functions, see [Function Handle Callbacks](#).

See the `BeingDeleted` property for related information.

**DisplayName**  
string

*String used by legend.* The `legend` function uses the `DisplayName` property to label the stairseries object in the legend. The default is an empty string.

- If you specify string arguments with the `legend` function, MATLAB set `DisplayName` to the corresponding string and uses that string for the legend.
- If `DisplayName` is empty, `legend` creates a string of the form, `['data' n]`, where `n` is the number assigned to the object based on its location in the list of legend entries. However, `legend` does not set `DisplayName` to this string.
- If you edit the string directly in an existing legend, MATLAB set `DisplayName` to the edited string.
- If you specify a string for the `DisplayName` property and create the legend using the figure toolbar, then MATLAB uses the string defined by `DisplayName`.
- To add a legend programmatically that uses the `DisplayName` string, call `legend` with the `toggle` or `show` option.

See “Control Legend Content” for more information and examples.

**EraseMode**  
{normal} | none | xor | background

# Stairseries Properties

---

*Erase mode.* Controls the technique MATLAB uses to draw and erase objects. Use alternative erase modes for creating animated sequences, where control of the way individual objects are redrawn is necessary to improve performance and obtain the desired effect.

- **normal** — Redraw the affected region of the display, performing the three-dimensional analysis necessary to correctly render all objects. This mode produces the most accurate picture, but is the slowest. The other modes are faster, but do not perform a complete redraw and are therefore less accurate.
- **none** — Do not erase the object when it is moved or destroyed. While the object is still visible on the screen after erasing with `EraseMode none`, you cannot print it because MATLAB stores no information about its former location.
- **xor** — Draw and erase the object by performing an exclusive OR (XOR) with the color of the screen beneath it. This mode does not damage the color of the objects beneath it. However, the object's color depends on the color of whatever is beneath it on the display.
- **background** — Erase the object by redrawing it in the axes background `Color`, or the figure background `Color` if the axes `Color` property is `none`. This damages objects that are behind the erased object, but properly colors the erased object.

Set the axes background color with the axes `Color` property. Set the figure background color with the figure `Color` property.

## Printing with Nonnormal Erase Modes

MATLAB always prints figures as if the `EraseMode` of all objects is `normal`. This means graphics objects created with `EraseMode` set to `none`, `xor`, or `background` can look different on screen than on paper. On screen, MATLAB mathematically combines layers of colors (for example, performing an XOR on a pixel color with that of the pixel behind it) and ignore three-dimensional sorting

to obtain greater rendering speed. However, these techniques are not applied to the printed output.

You can use the `getframe` command or other screen capture applications to create an image of a figure containing nonnormal mode objects.

## HandleVisibility

`{on} | callback | off`

*Control access to object's handle.* Determines when an object's handle is visible in its parent's list of children. `HandleVisibility` is useful for preventing command-line users from accidentally accessing objects that you need to protect for some reason.

- `on` — Handles are always visible.
- `callback` — Handles are visible from within callback routines or functions invoked by callback routines, but not from within functions invoked from the command line. This provides a means to protect GUIs from command-line users, while allowing callback routines to have access to object handles.
- `off` — Handles are invisible at all times. Use this option when a callback invokes a function that could damage the GUI (such as evaluating a user-typed string). This option temporarily hides its own handles during the execution of that function.

## Functions Affected by Handle Visibility

When a handle is not visible in its parent's list of children, it cannot be returned by functions that obtain handles by searching the object hierarchy or querying handle properties. This includes `get`, `findobj`, `gca`, `gcf`, `gco`, `newplot`, `cla`, `clf`, and `close`.

## Properties Affected by Handle Visibility

When a handle's visibility is restricted using `callback` or `off`, the object's handle does not appear in its parent's `Children` property,

# Stairseries Properties

---

figures do not appear in the root's `CurrentFigure` property, objects do not appear in the root's `CallbackObject` property or in the figure's `CurrentObject` property, and axes do not appear in their parent's `CurrentAxes` property.

## Overriding Handle Visibility

You can set the root `ShowHiddenHandles` property to on to make all handles visible regardless of their `HandleVisibility` settings. This does not affect the values of the `HandleVisibility` properties. See also `findall`.

## Handle Validity

Hidden handles are still valid. If you know an object's handle, you can `set` and `get` its properties and pass it to any function that operates on handles.

---

**Note** If you change one data source property to a variable that contains data of a different dimension, you might cause the function to generate a warning and not render the graph until you have changed all data source properties to appropriate values.

---

`HitTest`  
`{on} | off`

*Selectable by mouse click.* Determines whether this object can become the current object (as returned by the `gco` command and the figure `CurrentObject` property) as a result of a mouse click on the line objects that compose the stairstep graph. If `HitTest` is off, clicking this object selects the object below it (which is usually the axes containing it).

`HitTestArea`  
`on | {off}`



Select the object by clicking lines or area of extent. Select plot objects by:

- Clicking lines (default).
- Clicking anywhere in the extent of the plot.

When `HitTestArea` is off, you must click the lines to select the object. When `HitTestArea` is on, you can select this object by clicking anywhere within the extent of the plot (that is, anywhere within a rectangle that encloses the stairstep graph).

`Interruptible`  
off | {on}

*Callback routine interruption*

Controls whether MATLAB can interrupt an object's callback function when subsequent callbacks attempt to interrupt it.

For Graphics objects, the `Interruptible` property affects only the callbacks for the `ButtonDownFcn` property. A *running* callback is the currently executing callback. The *interrupting* callback is the callback that tries to interrupt the *running* callback. MATLAB handles both the callbacks based on the `Interruptible` property of the object of the *running* callback.

When the `Interruptible` property is set to:

- 'off', MATLAB finishes execution of the *running* callback without any interruptions
- 'on', these conditions apply:
  - If there is a `drawnow`, `figure`, `getframe`, `waitfor`, or `pause` command in the *running* callback, then MATLAB executes the *interrupting* callbacks which are already in the queue and returns to finish execution of the current callback.

# Stairseries Properties

---

- If one of the above functions is not in the *running* callback, then MATLAB finishes execution of the current callback without any interruption.

BusyAction property of the object of interrupting callback determines whether the callback should be ignored or should be put in the queue.

Setting Interruptible property to on (default), allows a callback from other graphics objects to interrupt callback functions originating from this object.

---

**Note** MATLAB does not save the state of properties or the display when an interruption occurs. For example, the handle returned by the `gca` or `gcf` command may be changed as another callback is executed.

---

After the function that interrupts a callback completes, the callback resumes execution where it halted when interrupted. For more information, see “Control Callback Execution and Interruption”.

LineStyle

{-} | -- | : | -. | none

*Line style of stairseries object.*

## Line Style Specifiers Table

Specifier	Line Style
'-'	Solid line (default)
'--'	Dashed line
':'	Dotted line

Specifier	Line Style
'-.'	Dash-dot line
'none'	No line

Use `LineStyle none` when you want to place a marker at each point but do not want the points connected with a line (see the `Marker` property).

#### `LineWidth`

size in points

*Width of linear objects and edges of filled areas.* Specify in points. 1 point =  $\frac{1}{72}$  inch. The default is 0.5 points.

#### `Marker`

character (see table)

*Marker symbol.* Specifies marks that display at data points. You can set values for the `Marker` property independently from the `LineStyle` property. For a list of supported marker symbols, see the following table.

#### Marker Specifiers Table

Specifier	Marker Type
'+'	Plus sign
'o'	Circle
'*'	Asterisk
'.'	Point
'x'	Cross
'square' or 's'	Square
'diamond' or 'd'	Diamond

# Stairseries Properties

---

Specifier	Marker Type
'^'	Upward-pointing triangle
'v'	Downward-pointing triangle
'>'	Right-pointing triangle
'<'	Left-pointing triangle
'pentagram' or 'p'	Five-pointed star (pentagram)
'hexagram' or 'h' 'H'	Six-pointed star (hexagram)
'none'	No marker (default)

## MarkerEdgeColor

ColorSpec | none | {auto}

*Marker edge color.* The color of the marker or the edge color for filled markers (circle, square, diamond, pentagram, hexagram, and the four triangles).

- ColorSpec — User-defined color.
- none — Specifies no color, which makes nonfilled markers invisible.
- auto — Uses same color as the Color property.

## MarkerFaceColor

ColorSpec | {none} | auto

*Fill color for closed-shape markers.* The fill color for markers that are closed shapes (circle, square, diamond, pentagram, hexagram, and the four triangles).

- ColorSpec — User-defined color.
- none — Makes the interior of the marker transparent, allowing the background to show through.
- auto — Sets the fill color to the axes Color property. If the axes Color property is none, sets the fill color to the figure Color.

MarkerSize  
scalar

*Marker size.* Size of the marker in points. The default value is 6.

---

**Note** MATLAB draws the point marker (specified by the ' .' symbol) at one-third the specified size.

---

Parent  
handle of parent axes, hggroup, or hgtransform

*Parent of object.* Handle of the object's parent. The parent is normally the axes, hggroup, or hgtransform object that contains the object.

Selected  
on | {off}

*Object selection state.* When you set this property to on, MATLAB displays selection handles at the corners and midpoints if the SelectionHighlight property is also on (the default). You can, for example, define the ButtonDownFcn callback to set this property to on, thereby indicating that this particular object is selected. This property is also set to on when an object is manually selected in plot edit mode.

SelectionHighlight  
{on} | off

*Object highlighted when selected.*

- on — MATLAB indicates the selected state by drawing four edge handles and four corner handles.
- off — MATLAB does not draw the handles except when in plot edit mode and objects are selected manually.

# Stairseries Properties

---

## Tag

string

*User-specified object label.* Provides a means to identify graphics objects with a user-specified label. The default is an empty string.

Use the `Tag` property and the `findobj` function to manipulate specific objects within a plotting hierarchy.

For example, create an `areaseries` object and set the `Tag` property.

```
t = area(Y, 'Tag', 'area1')
```

When you want to access objects of a given type, use `findobj` to find the object's handle. The following statement changes the `FaceColor` property of the object whose `Tag` is `area1`.

```
set(findobj('Tag', 'area1'), 'FaceColor', 'red')
```

## Type

string (read-only)

*Type of graphics object.* String that identifies the class of the graphics object. Use this property to find all objects of a given type within a plotting hierarchy. For stairseries objects, `Type` is `'hggroup'`. The following statement finds all the `hggroup` objects in the current axes object.

```
t = findobj(gca, 'Type', 'hggroup');
```

## UIContextMenu

handle of `uicontextmenu` object

*Associate context menu with object.* Handle of a `uicontextmenu` object created in the object's parent figure. Use the `uicontextmenu` function to create the context menu. MATLAB displays the context menu whenever you right-click over the object. The default value is an empty array.

## UserData

array

*User-specified data.* Data you want to associate with this object (including cell arrays and structures). The default value is an empty array. MATLAB does not use this data, but you can access it using the `set` and `get` commands.

## Visible

{on} | off

*Visibility of object and its children.*

- `on` — Object and all children of the object are visible unless the child object's `Visible` property is `off`.
- `off` — Object not displayed. However, the object still exists and you can set and query its properties.

## XData

array

*X-axis location of stairs.* The `stairs` function uses `XData` to label the *x*-axis. `XData` can be either a matrix equal in size to `YData` or a vector equal in length to the number of rows in `YData`. That is, `length(XData) == size(YData,1)`.

If you do not specify `XData` (which the input argument `X`), the `stairs` function uses the indices of `YData` to create the staircase graph. See the `XDataMode` property for related information.

## XDataMode

{auto} | manual

*Use automatic or user-specified x-axis values.* If you specify `XData` (by setting the `XData` property or specifying the `X` input argument), MATLAB sets this property to `manual` and uses the specified values to label the *x*-axis.

# Stairseries Properties

---

If you set `XDataMode` to `auto` after specifying `XData`, MATLAB resets the *x*-axis ticks to `1:size(YData,1)` or to the column indices of the `ZData`, overwriting any previous values for `XData`.

## `XDataSource`

MATLAB variable, as a string

*Link XData to MATLAB variable.* Set this property to a MATLAB variable that is evaluated in the base workspace to generate the `XData`. The default value is an empty array.

```
set(h, 'XDataSource', 'xdatavariablename')
```

MATLAB requires a call to `refreshdata` when you set this property. Changing workspace variables used as an object's `XDataSource` does not change the object's `XData` values, but you can use `refreshdata` to force an update of the object's data. `refreshdata` also lets you specify that the data source variable be evaluated in the workspace of a function from which you call `refreshdata`.

---

**Note** If you change one data source property to a variable that contains data of a different dimension, you might cause the function to generate a warning and not render the graph until you have changed all data source properties to appropriate values.

---

## `YData`

scalar | vector | matrix

*Stairs plot data.* `YData` contains the data plotted in the stairstep graph. Each value in `YData` is represented by a marker in the stairstep graph. If `YData` is a matrix, the `stairs` function creates a line for each column in the matrix.

The input argument `Y` in the `stairs` function calling syntax assigns values to `YData`.



## YDataSource

MATLAB variable, as a string

*Link YData to MATLAB variable.* Set this property to a MATLAB variable that is evaluated in the base workspace to generate the YData. The default value is an empty array.

```
set(h, 'YDataSource', 'Ydatavariablename')
```

MATLAB requires a call to `refreshdata` when you set this property. Changing workspace variables used as an object's YDataSource does not change the object's YData values, but you can use `refreshdata` to force an update of the object's data. `refreshdata` also lets you specify that the data source variable be evaluated in the workspace of a function from which you call `refreshdata`.

---

**Note** If you change one data source property to a variable that contains data of a different dimension, you might cause the function to generate a warning and not render the graph until you have changed all data source properties to appropriate values.

---

# standardizeMissing

---

**Purpose** Insert missing value indicators into table

**Syntax**  
B = standardizeMissing(A,id)  
B = standardizeMissing(A,id,'DataVariables',vars)

**Description** B = standardizeMissing(A,id) replaces all instances of the values specified in id occurring within table A with the standard missing value indicators. B is a table.

The standard missing value indicators depend on the data type:

- NaN for double and single floating-point arrays
- <undefined> for categorical arrays
- empty string, { ' ' }, for cell arrays of strings
- blank string, [ ' ' ], for character arrays

standardizeMissing checks double and single variables in A against numeric values from id and checks string and categorical variables in A against strings from id. The function standardizeMissing ignores integer data types because they cannot contain NaN.

B = standardizeMissing(A,id,'DataVariables',vars) replaces values only in variables specified by vars.

## Input Arguments

### A - Input table

table

Input table, specified as a table.

### id - Nonstandard missing value indicators

numeric vector | string | cell array containing numeric values and strings

Nonstandard missing value indicators, specified as a numeric vector, string, or cell array containing numeric values and strings.

### vars - Subset of variables to consider

positive integer | vector of positive integers | variable name | cell array of variable names | logical vector

Subset of variables to consider, specified as a positive integer, vector of positive integers, variable name, cell array of variable names, or logical vector.

## Output Arguments

### B - Output table

table

Output table, returned as a table. The table can store metadata such as descriptions, variable units, variable names, and row names. For more information, see [Table Properties](#).

## Examples

### Replace All Instances of Specified Values

Create a table containing Inf and 'N/A' to represent missing values.

```
dblVar = [NaN;3;Inf;7;9];
cellstrVar = {'one';'three';'';'NA';'nine'};
charVar = ['A';'C';'E';' ';'I'];
categoryVar = categorical({'red';'yellow';'blue';'violet';''});
```

```
A = table(dblVar,cellstrVar,charVar,categoryVar)
```

A =

dblVar	cellstrVar	charVar	categoryVar
NaN	'one'	A	red
3	'three'	C	yellow
Inf	''	E	blue
7	'NA'		violet
9	'nine'	I	<undefined>

Replace all instances of Inf with NaN and replace all instances of 'NA' with the empty string, ''.

# standardizeMissing

---

```
B = standardizeMissing(A,{Inf,'NA'})
```

```
B =
```

dblVar	cellstrVar	charVar	categoryVar
NaN	'one'	A	red
3	'three'	C	yellow
NaN	''	E	blue
7	''		violet
9	'nine'	I	<undefined>

## Replace Only Values in Specified Variables

Replace instances of `Inf`, and `'N/A'`, occurring in specified variables of a table, with the standard missing value indicators.

Create a table containing `Inf` and `'N/A'` to represent missing values.

```
a = {'alpha';'bravo';'charlie';'';'N/A'};
x = [1;NaN;3;Inf;5];
y = [57;732;93;1398;Inf];
```

```
A = table(a,x,y)
```

```
A =
```

a	x	y
'alpha'	1	57
'bravo'	NaN	732
'charlie'	3	93
''	Inf	1398
'N/A'	5	Inf

For the variables `a` and `x`, replace instances of `Inf` with `NaN` and `'N/A'` with the empty string, `''`.

```
B = standardizeMissing(A,{Inf,'N/A'},'DataVariables',{ 'a', 'x' })
```

```
B =
```

a	x	y
'alpha'	1	57
'bravo'	NaN	732
'charlie'	3	93
''	NaN	1398
''	5	Inf

Inf in the variable y remains unchanged because y is not included in the 'DataVariables' name-value pair argument.

## Algorithms

`standardizeMissing` treats leading and trailing white space differently for cell arrays of strings, character arrays, and categorical arrays.

- For cell arrays of strings, `standardizeMissing` does not ignore white space. All strings must match exactly a string specified in `id`.
- For character arrays, `standardizeMissing` ignores trailing white space.
- For categorical arrays, `standardizeMissing` ignores leading and trailing white space.

## See Also

`ismissing` | `table`

# startup

---

**Purpose** Startup file for user-defined options

**Syntax** startup

**Description** startup executes commands of your choosing when the MATLAB program starts.

Create a `startup.m` file in your MATLAB “Startup Folder” on page 1-6508 and put in the file any commands you want executed at MATLAB startup. For example, your `startup.m` file might include physical constants, defaults for Handle Graphics properties, engineering conversion factors, or anything else you want predefined in your workspace.

**Algorithms** The MATLAB program executes the `matlabrc.m` file when it starts. `matlabrc.m` invokes `startup.m`, if it exists on the MATLAB search path.

You can extend this process to create additional startup files, if needed.

MathWorks does not recommend modifying the `matlabrc.m` file, except perhaps by system administrators in network configurations.

**Definitions** **Startup Folder**

The current folder in the MATLAB application when it starts. See “MATLAB Startup Folder”.

**See Also** finish | matlabrc | matlabroot | path | quit | userpath

**Concepts**

- “Specifying Startup Options in MATLAB Startup File”
- Preferences

**Purpose** Standard deviation

**Syntax**  
`s = std(X)`  
`s = std(X, flag)`  
`s = std(X, flag, dim)`

**Definitions** There are two common textbook definitions for the standard deviation `s` of a data vector `X`.

$$(1) s = \left( \frac{1}{n-1} \sum_{i=1}^n (x_i - \bar{x})^2 \right)^{\frac{1}{2}}$$

$$(2) s = \left( \frac{1}{n} \sum_{i=1}^n (x_i - \bar{x})^2 \right)^{\frac{1}{2}},$$

where

$$\bar{x} = \frac{1}{n} \sum_{i=1}^n x_i$$

and  $n$  is the number of elements in the sample. The two forms of the equation differ only in  $n - 1$  versus  $n$  in the divisor.

**Description** `s = std(X)`, where `X` is a vector, returns the standard deviation using (1) above. The result `s` is the square root of an unbiased estimator of the variance of the population from which `X` is drawn, as long as `X` consists of independent, identically distributed samples.

If `X` is a matrix, `std(X)` returns a row vector containing the standard deviation of the elements of each column of `X`. If `X` is a multidimensional array, `std(X)` is the standard deviation of the elements along the first nonsingleton dimension of `X`.

`s = std(X,flag)` for `flag = 0`, is the same as `std(X)`. For `flag = 1`, `std(X,1)` returns the standard deviation using (2) above, producing the second moment of the set of values about their mean.

`s = std(X,flag,dim)` computes the standard deviations along the dimension of `X` specified by scalar `dim`. Set `flag` to 0 to normalize `Y` by  $n-1$ ; set `flag` to 1 to normalize by  $n$ .

The input array, `X`, must be of type `double` or `single` for all syntaxes.

## Examples

For matrix `X`

```
X =
 1 5 9
 7 15 22
s = std(X,0,1)
s =
 4.2426 7.0711 9.1924
s = std(X,0,2)
s =
 4.000
 7.5056
```

## See Also

`corrcoef` | `cov` | `mean` | `median` | `var`



**Purpose** Plot discrete sequence data

**Syntax**

```
stem(Y)
stem(X,Y)
stem(__, 'fill')
stem(__, LineSpec)
stem(__, Name, Value)

stem(axes_handle, __)

h = stem(__)
```

**Description** `stem(Y)` plots the data sequence, `Y`, as stems that extend from a baseline along the  $x$ -axis. The data values are indicated by circles terminating each stem.

- If `Y` is a vector, then the  $x$ -axis scale ranges from 1 to `length(Y)`.
- If `Y` is a matrix, then `stem` plots all elements in a row against the same  $x$  value, and the  $x$ -axis scale ranges from 1 to the number of rows in `Y`.

`stem(X,Y)` plots the data sequence, `Y`, at values specified by `X`. The `X` and `Y` inputs must be vectors or matrices of the same size. Additionally, `X` can be a row or column vector and `Y` must be a matrix with `length(X)` rows.

- If `X` and `Y` are both vectors, then `stem` plots entries in `Y` against corresponding entries in `X`.
- If `X` is a vector and `Y` is a matrix, then `stem` plots each column of `Y` against the set of values specified by `X`, such that all elements in a row of `Y` are plotted against the same value.
- If `X` and `Y` are both matrices, then `stem` plots columns of `Y` against corresponding columns of `X`.

`stem(__, 'fill')` fills the circles. Use this option with any of the input argument combinations in the previous syntaxes.

# stem

---

`stem(___,LineStyleSpec)` specifies the line style, marker symbol, and color.

`stem(___,Name,Value)` specifies stemseries properties using one or more `Name,Value` pair arguments.

`stem(axes_handle,___)` plots into the axes specified by `axes_handle` instead of into the current axes (`gca`). The option, `axes_handle`, can precede any of the input argument combinations in the previous syntaxes.

`h = stem(___)` returns a vector of stemseries object handles in `h`. When multiple stemseries objects are present, you can make changes to properties of a specific stemseries by specifying a particular handle.

## Input Arguments

### **Y - Data sequence to display**

*vector or matrix*

Data sequence to display, specified as a vector or matrix. When `Y` is a vector, `stem` creates one stemseries. When `Y` is a matrix, `stem` creates a separate stemseries for each column.

#### **Data Types**

single | double | int8 | int16 | int32 | int64 | uint8 |  
uint16 | uint32 | uint64 | logical

### **X - Locations to plot data values in Y**

*vector or matrix*

Locations to plot data values in `Y`, specified as a vector or matrix. When `Y` is a vector, `X` must be a vector of the same size. When `Y` is a matrix, `X` must be a matrix of the same size, or a vector whose length equals the number of rows in `Y`.

#### **Data Types**

single | double | int8 | int16 | int32 | int64 | uint8 |  
uint16 | uint32 | uint64 | logical

**LineStyle - Line style, marker symbol, and color**

string

Line style, marker symbol, and color, specified as a string. For more information on line style, marker symbol, and color options see `LineStyle`.

**Example:** `':*r'`

**Data Types**

char

**axes\_handle - Axes handle**

handle

Axes handle, which is the reference to an axes object. Use the `gca` function to get the handle to the current axes, for example, `axes_handle = gca;`

**Name-Value Pair Arguments**

Specify optional comma-separated pairs of `Name`, `Value` arguments. `Name` is the argument name and `Value` is the corresponding value. `Name` must appear inside single quotes ( `' '` ). You can specify several name and value pair arguments in any order as `Name1,Value1,...,NameN,ValueN`.

**Example:** `'LineStyle',':', 'MarkerFaceColor','red'` plots the stem as a dotted line and colors the marker face red.

For more information on these properties see `stemseries`.

**'LineStyle' - Line style**

`'-'` (default) | `'--'` | `':'` | `'-.'` | `'none'`

Line style, specified as the comma-separated pair consisting of `'LineStyle'` and a line style specifier. This table lists supported line styles.

Specifier	Line Style
'-'	Solid line (default)
'--'	Dashed line
':'	Dotted line
'-.'	Dash-dot line
'none'	No line

**Example:** 'LineStyle','-.'

### 'LineWidth' - Line width

0.5 (default) | scalar

Line width, specified as the comma-separated pair consisting of 'LineWidth' and a scalar. The scalar sets the width size in points of the stem and marker edge.

**Example:** 'LineWidth',0.75

### 'Color' - Color

[0 0 1] (blue) (default) | three-element RGB vector | string

Color, specified as the comma-separated pair consisting of 'Color' and a three-element RGB vector or a string containing the short or long name of the color. The RGB vector is a three-element row vector whose elements specify the intensities of the red, green, and blue components of the color. The intensities must be in the range [0 1].

This table lists the predefined colors and their RGB equivalents.

RGB Vector	Short Name	Long Name
[1 1 0]	'y'	'yellow'
[1 0 1]	'm'	'magenta'

RGB Vector	Short Name	Long Name
[0 1 1]	'c'	'cyan'
[1 0 0]	'r'	'red'
[0 1 0]	'g'	'green'
[0 0 1]	'b'	'blue'
[1 1 1]	'w'	'white'
[0 0 0]	'k'	'black'

**Example:** 'Color', [0 1 0]

**Example:** 'Color', 'green'

**Example:** 'Color', 'g'

### 'Marker' - Marker symbol

'o' (default) | string

Marker symbol, specified as the comma-separated pair consisting of 'Marker' and a marker specifier. This table lists supported marker symbols.

Specifier	Marker Symbol
'o'	Circle
'+'	Plus sign
'*'	Asterisk
'.'	Point
'x'	Cross
'square' or 's'	Square
'diamond' or 'd'	Diamond
'^'	Upward-pointing triangle

Specifier	Marker Symbol
'v'	Downward-pointing triangle
'>'	Right-pointing triangle
'<'	Left-pointing triangle
'pentagram' or 'p'	Five-pointed star (pentagram)
'hexagram' or 'h'	Six-pointed star (hexagram)
'none'	No marker

**Example:** 'Marker', '+'

**Example:** 'Marker', 'diamond'

### 'MarkerEdgeColor' - Marker edge color

'auto' (default) | 'none' | three-element RGB vector | string

Marker edge color, specified as the comma-separated pair consisting of 'MarkerEdgeColor' and a color value. The color value can be one of the supported strings or an RGB vector, listed in the following tables.

Specifier	Result
'auto'	Uses same color as line color
'none'	Specifies no color, which makes unfilled markers invisible

For an RGB vector, use a three-element row vector whose elements specify the intensities of the red, green, and blue components of the color. The intensities must be in the range [0 1]. This table lists the predefined string colors and their RGB equivalents.

RGB Vector	Short Name	Long Name
[1 1 0]	'y'	'yellow'
[1 0 1]	'm'	'magenta'

RGB Vector	Short Name	Long Name
[0 1 1]	'c'	'cyan'
[1 0 0]	'r'	'red'
[0 1 0]	'g'	'green'
[0 0 1]	'b'	'blue'
[1 1 1]	'w'	'white'
[0 0 0]	'k'	'black'

**Example:** 'MarkerEdgeColor',[1 .8 .1]

### 'MarkerFaceColor' - Marker face color

'none' (default) | 'auto' | three-element RGB vector | string

Marker face color, specified as the comma-separated pair consisting of 'MarkerFaceColor' and a color value. MarkerFaceColor sets the fill color for markers that are closed shapes (circle, square, diamond, pentagram, hexagram, and the four triangles). The color value can be one of the supported strings or an RGB vector, listed in the following tables.

Specifier	Result
'auto'	Uses same color as marker edge color
'none'	Makes the interior of the marker transparent, allowing the background to show through (default)

For an RGB vector, use a three-element row vector whose elements specify the intensities of the red, green, and blue components of the color. The intensities must be in the range [0 1]. This table lists the predefined string colors and their RGB equivalents.

RGB Vector	Short Name	Long Name
[1 1 0]	'y'	'yellow'
[1 0 1]	'm'	'magenta'
[0 1 1]	'c'	'cyan'
[1 0 0]	'r'	'red'
[0 1 0]	'g'	'green'
[0 0 1]	'b'	'blue'
[1 1 1]	'w'	'white'
[0 0 0]	'k'	'black'

**Example:** 'MarkerFaceColor',[0 .8 1]

### 'MarkerSize' - Marker size

6 (default) | scalar

Marker size, specified as the comma-separated pair consisting of 'MarkerSize' and a scalar in points.

**Example:** 'MarkerSize',3.75

## Output Arguments

### h - Stemseries object handle

scalar or column vector

Stemseries object handle, returned as a scalar or column vector. This is a unique identifier, which you can use to query and modify the properties of a specific stemseries.

## Examples

### Plot Single Data Series

Create a stem plot of 50 data values between  $-2\pi$  and  $2\pi$ .

```
figure
Y = linspace(-2*pi,2*pi,50);
stem(Y)
```



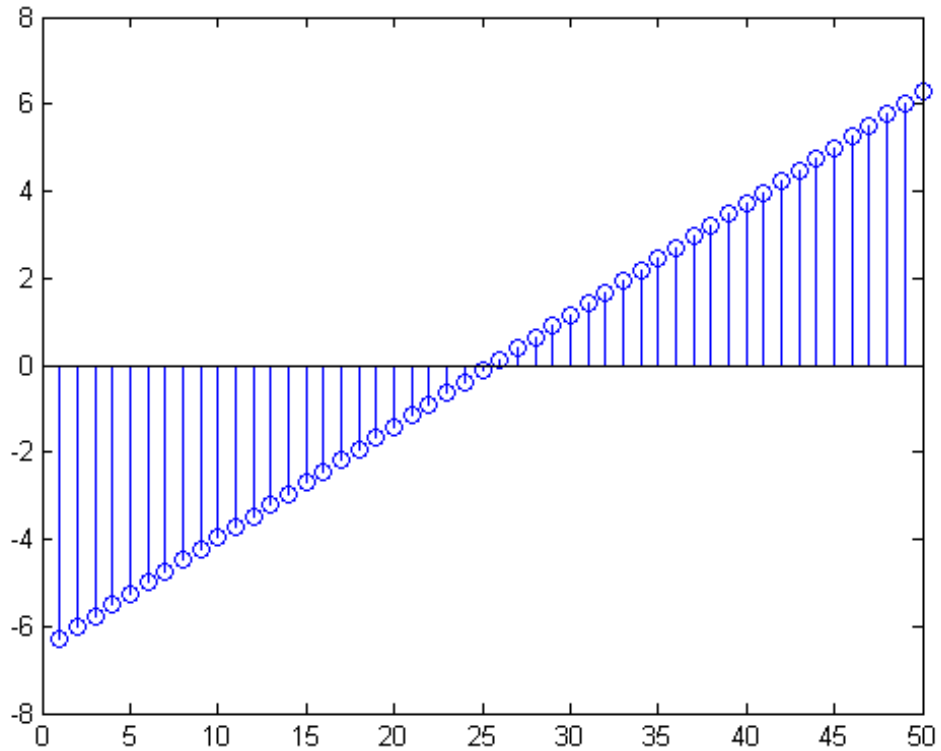

Data values are plotted as stems extending from the baseline and terminating at the data value. The length of  $Y$  automatically determines the position of each stem on the  $x$ -axis.

### Plot Multiple Data Series

Plot two data series using a two-column matrix.

```
figure
X = linspace(0,2*pi,50)';
Y = [cos(X), 0.5*sin(X)];
```

# stem

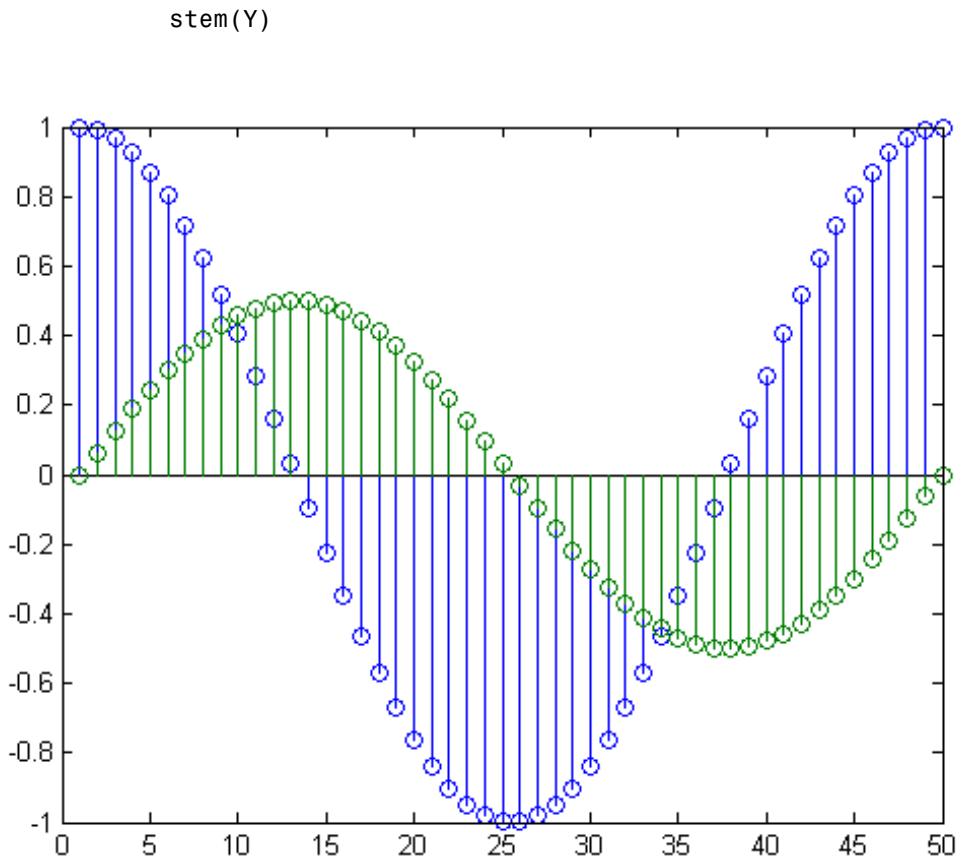

Each column of  $Y$  is plotted as a separate series, and entries in the same row of  $Y$  are plotted against the same  $x$  value. The number of rows in  $Y$  automatically generates the position of each stem on the  $x$ -axis.

## Plot Single Data Series at Specified $x$ values

Plot 50 data values of cosine evaluated between 0 and  $2\pi$  and specify the set of  $x$  values for the stem plot.

```
figure
X = linspace(0,2*pi,50)';
Y = cos(X);
stem(X,Y)
```

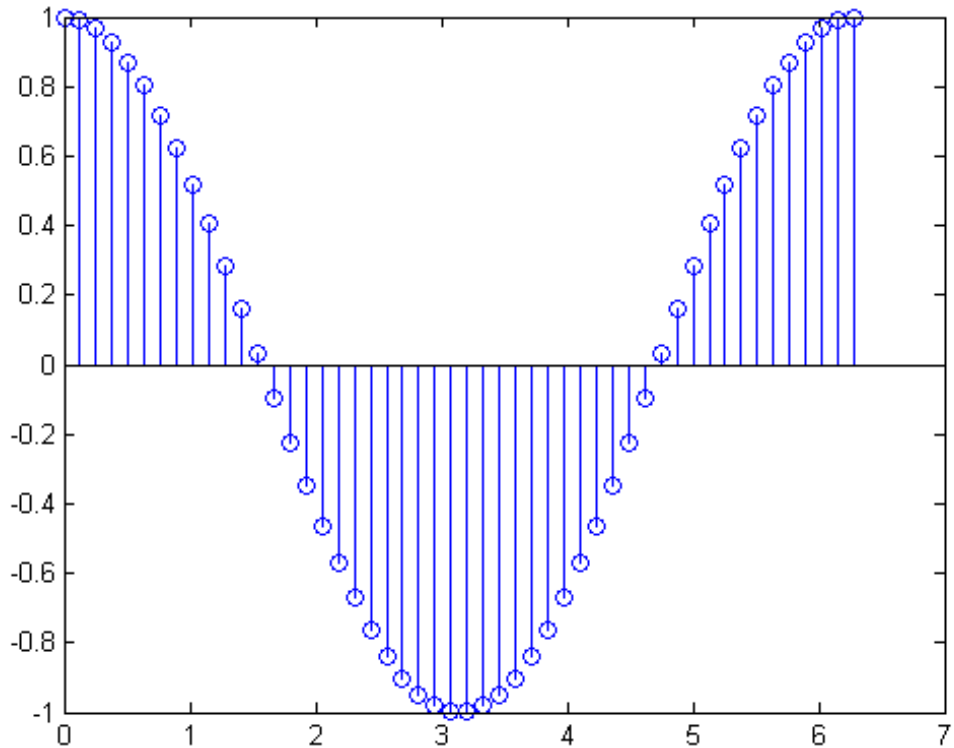

The first vector input determines the position of each stem on the  $x$ -axis.

### Plot Multiple Data Series at Specified $x$ values

Plot 50 data values of sine and cosine evaluated between 0 and  $2\pi$  and specify the set of  $x$  values for the stem plot.

# stem

```
figure
X = linspace(0,2*pi,50)';
Y = [cos(X), 0.5*sin(X)];
stem(X,Y)
```

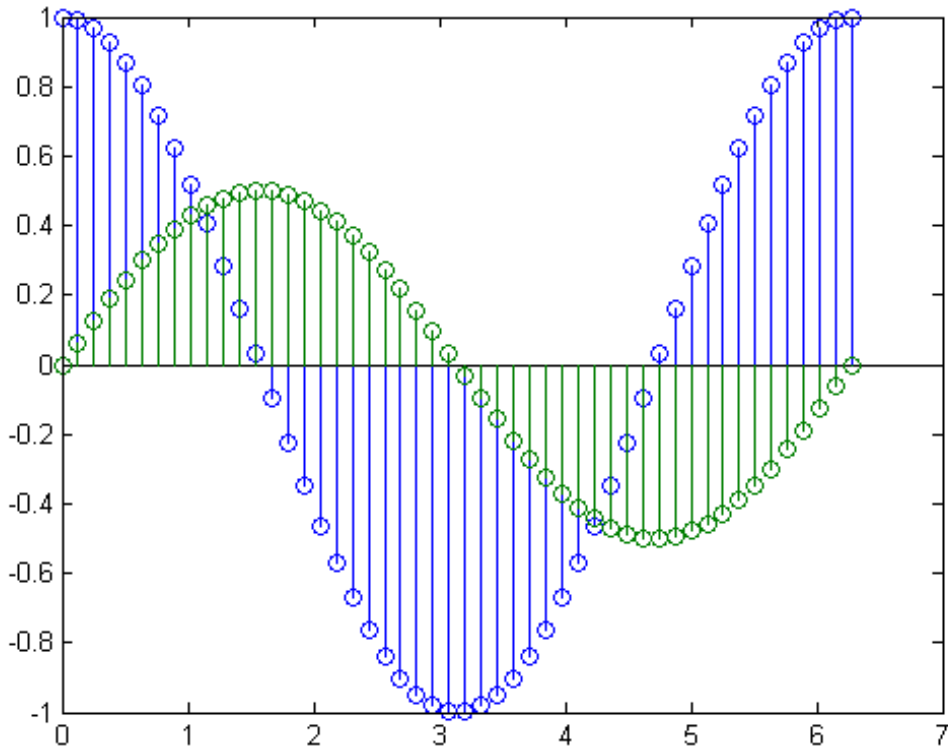

The vector input determines the  $x$ -axis positions for both data series.

## **Plot Multiple Data Series at Unique Sets of $x$ values**

Plot 50 data values of sine and cosine evaluated at different sets of  $x$  values. Specify the corresponding sets of  $x$  values for each series.

```
figure
x1 = linspace(0,2*pi,50)';
x2 = linspace(pi,3*pi,50)';
X = [x1, x2];
Y = [cos(x1), 0.5*sin(x2)];
stem(X,Y)
```

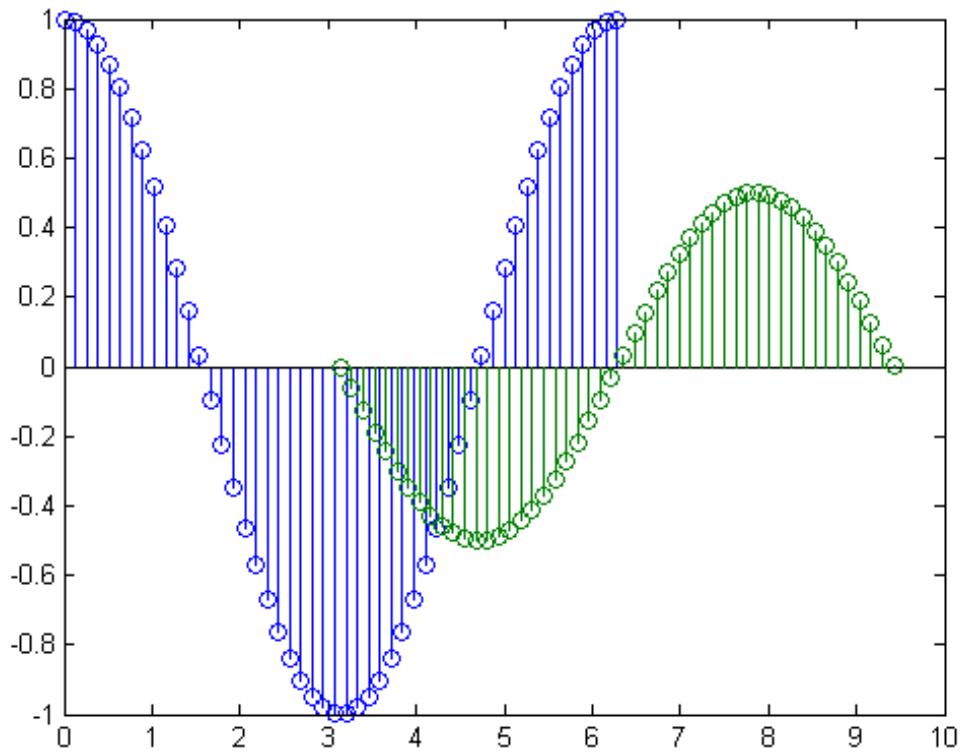

Each column of  $X$  is plotted against the corresponding column of  $Y$ .

# stem

---

## Fill in Plot Markers

Create a stem plot and fill in the circles that terminate each stem.

```
figure
X = linspace(0,10,20)';
Y = (exp(0.25*X));
stem(X,Y,'fill')
```

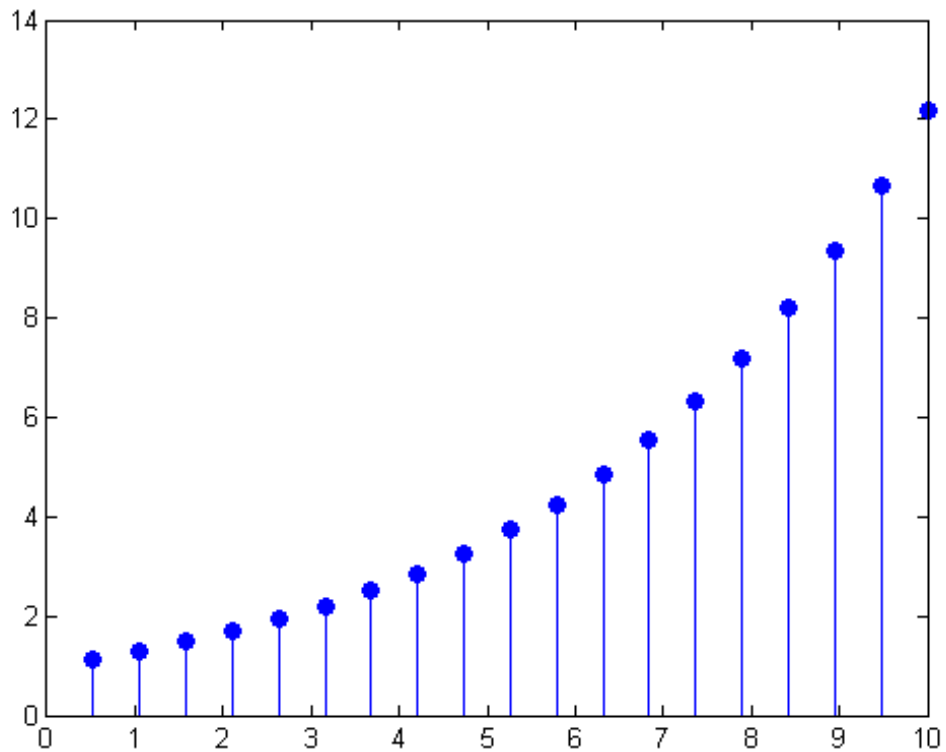

### Specify Stem and Marker Options

Create a stem plot and set the line style to a dotted line, the marker symbols to diamonds, and the color to red using the LineSpec option.

```
figure
X = linspace(0,2*pi,50)';
Y = (exp(X).*sin(X));
stem(X,Y,':diamondr')
```

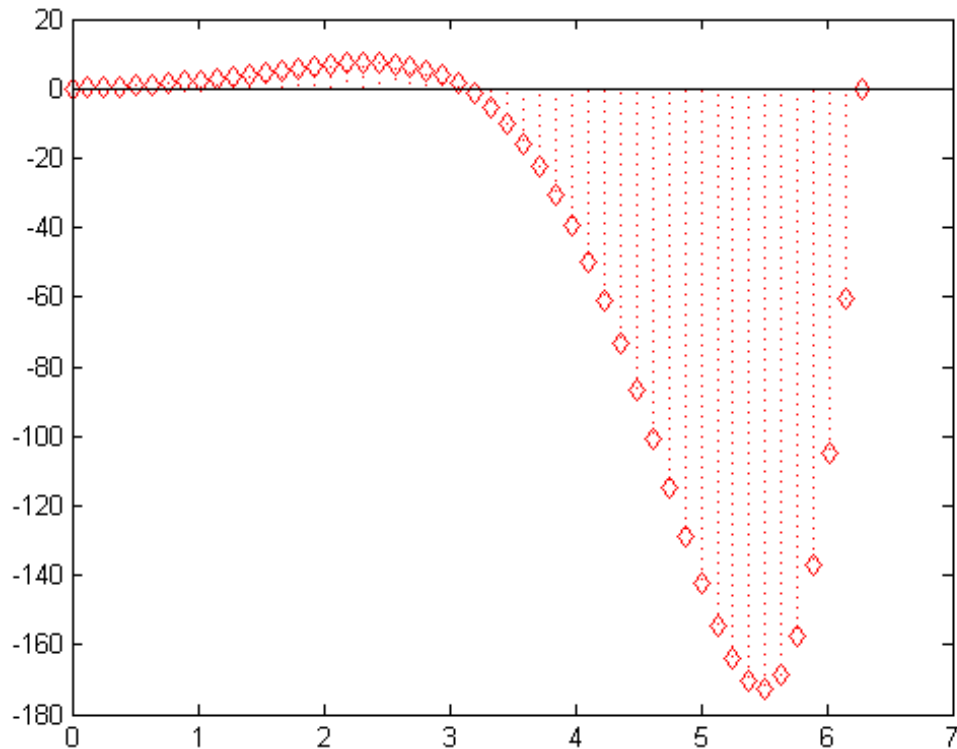

To color the inside of the diamonds, use the 'fill' option.

## **Specify Additional Stem and Marker Options**

Create a stem plot and set the line style to a dot-dashed line, the marker face color to red, and the marker edge color to green using Name,Value pair arguments.

```
figure
X = linspace(0,2*pi,25)';
Y = (cos(2*X));
stem(X,Y,'LineStyle','-.-',...
 'MarkerFaceColor','red',...
 'MarkerEdgeColor','green')
```



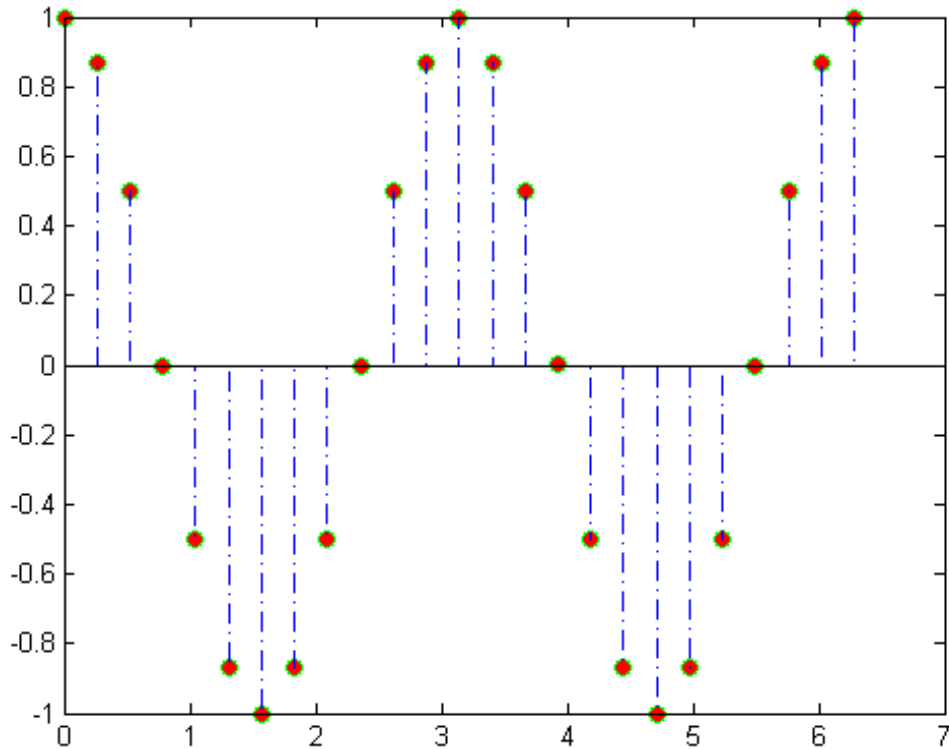

The stem remains the default color.

### Specify Axes for Stem Plot

Create a figure with two subplots and return the handles to each axes, `s(1)` and `s(2)`. Create a stem plot in the lower subplot by referring to its axes handle, `s(2)`.

```
figure
s(1) = subplot(2,1,1);
```

# stem

---

```
s(2) = subplot(2,1,2);

X = 0:25;
Y = [exp(0.1*X); -exp(.05*X)]';
stem(s(2),X,Y)
```

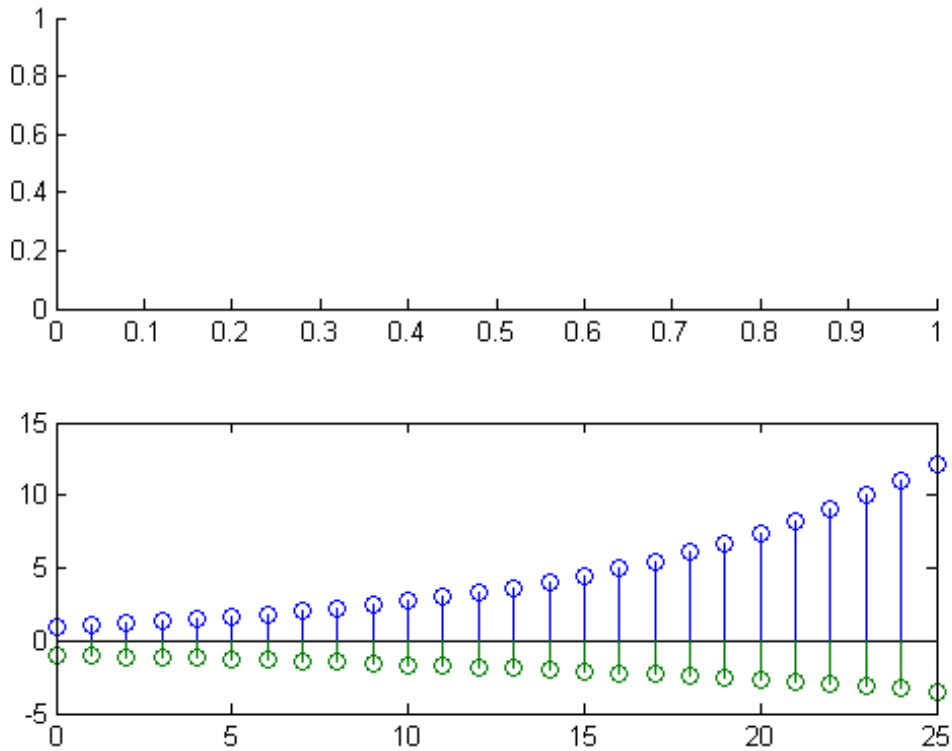

## Return Stemseries Handle

Create a stem plot of multiple data series and return the handle to each stemseries.

```
figure
X = 0:25;
Y = [cos(X); exp(0.05*X)]';
h = stem(X,Y);
```

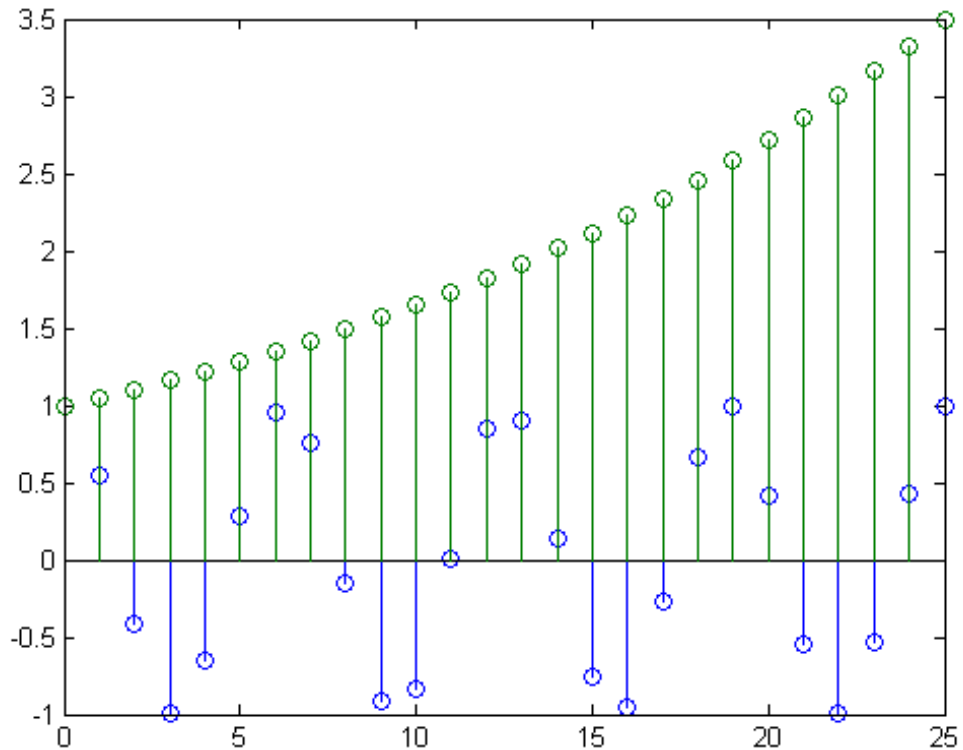

The `stem` function creates two `stemseries` objects, one for each column of data. The output argument, `h`, contains both `stemseries` handles.

Change the markers of the first series to blue circles and the second series to green squares using the handles.

# stem

```
set(h(1), 'MarkerFaceColor', 'blue')
set(h(2), 'MarkerFaceColor', 'green', 'Marker', 'square')
```

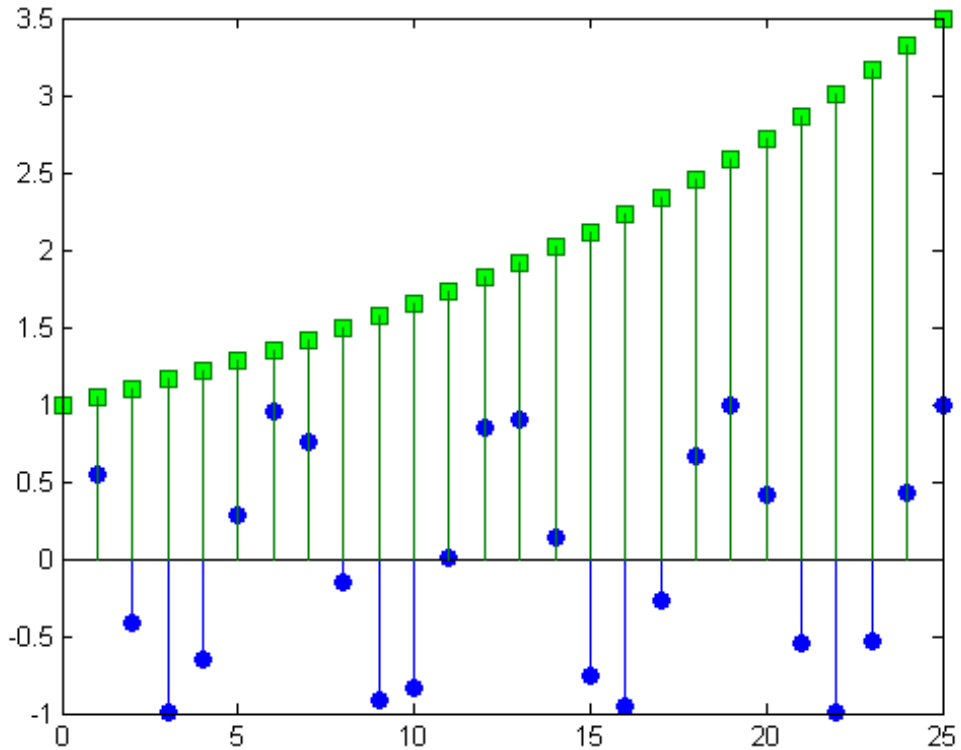

## Adjust Baseline Properties

Create a stem plot and change properties of the baseline.

```
figure
X = linspace(0,2*pi,50)';
Y = (exp(0.3*X).*sin(3*X));
```

```
h = stem(X,Y);
```

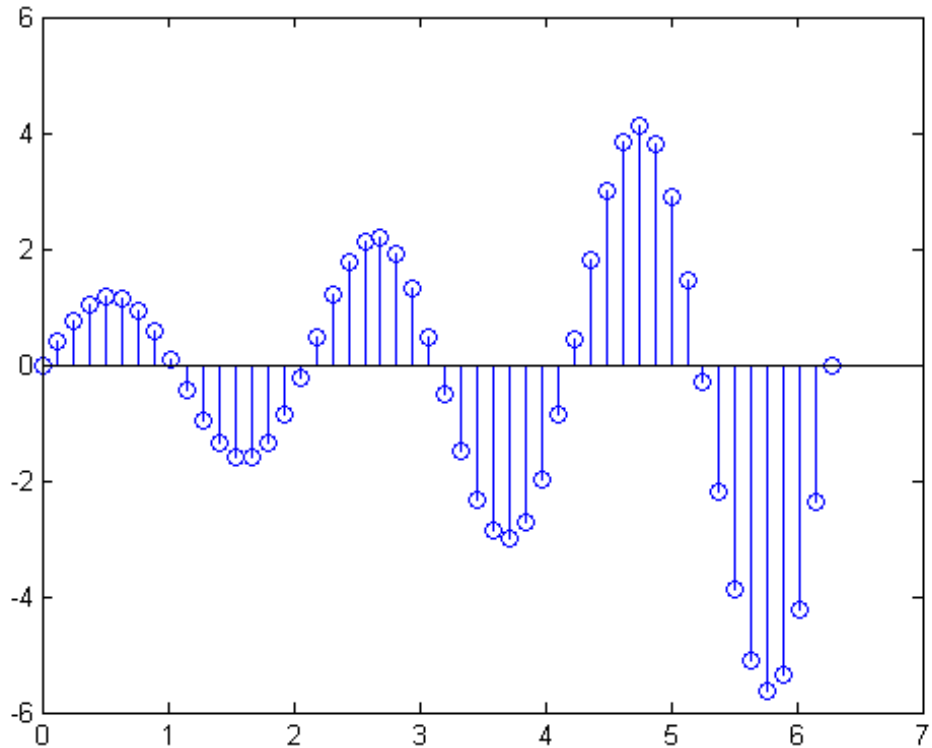

Get the baseline handle, `hbase`. Adjust the style of the baseline by setting its `LineStyle` property.

```
hbase = get(h,'Baseline');
set(hbase,'LineStyle','--')
```

# stem

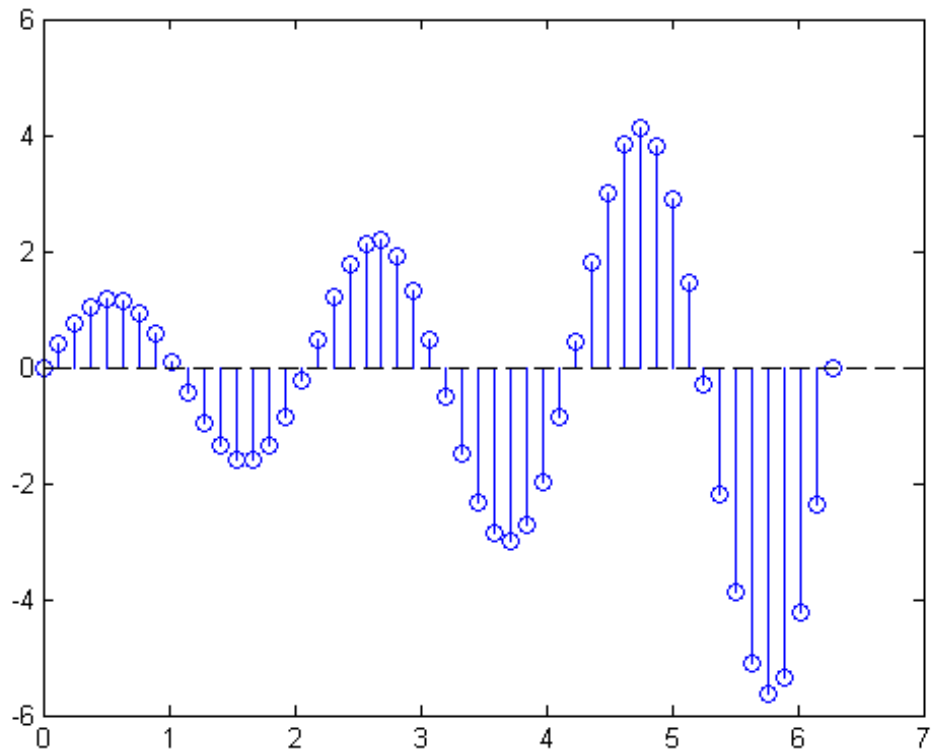

Make the baseline invisible by setting its `Visible` property to `'off'` .

```
set(hbase,'Visible','off')
```

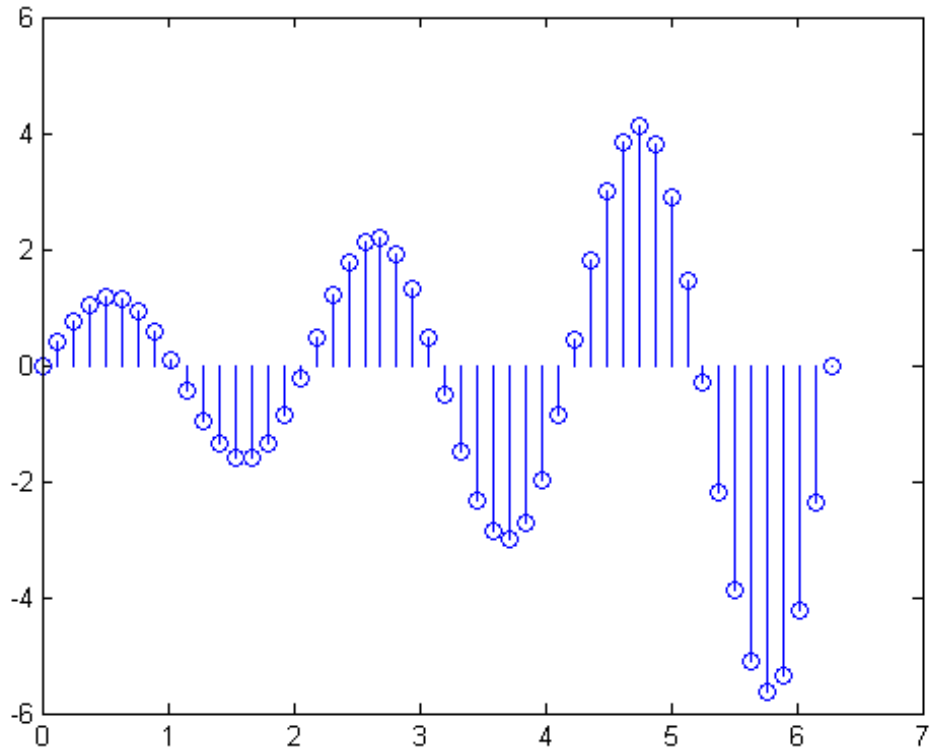

### Change the Baseline Level

Create a stem plot and change the baseline level to 2.

```
figure
X = linspace(0,2*pi,50)';
Y = (exp(0.3*X).*sin(3*X));
h = stem(X,Y);
set(h,'BaseValue',2);
```

# stem

---

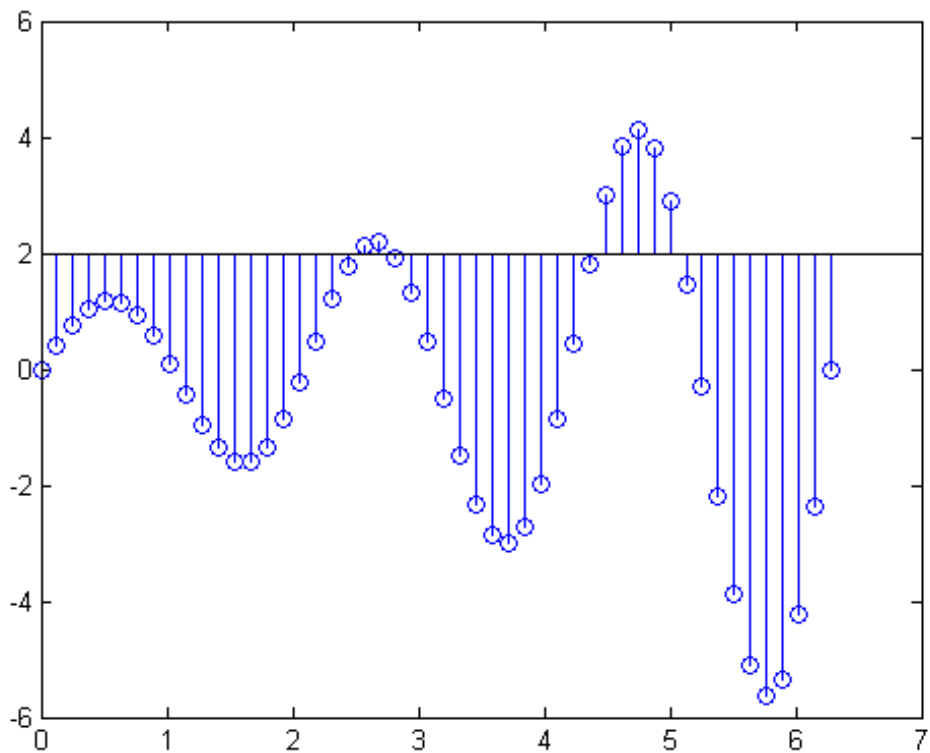

## See Also

[bar](#) | [plot](#) | [stairs](#) | [LineSpec](#) | [Stemsseries](#) |

## Related Examples

- “Combine Stem Plot and Line Plot”



**Purpose** Plot 3-D discrete sequence data

**Syntax**

```
stem3(Z)
stem3(X,Y,Z)
stem3(__,'fill')
stem3(__,LineStyle)
stem3(__,Name,Value)

stem3(axes_handle, __)

h = stem3(__)
```

**Description** `stem3(Z)` plots entries in *Z* as stems extending from the *xy*-plane and terminating with circles at the entry values. The stem locations in the *xy*-plane are automatically generated.

`stem3(X,Y,Z)` plots entries in *Z* as stems extending from the *xy*-plane where *X* and *Y* specify the stem locations in the *xy*-plane. The inputs *X*, *Y*, and *Z* must be vectors or matrices of the same size.

`stem3(__,'fill')` fills the circles. Use this option with any of the input argument combinations in the previous syntaxes.

`stem3(__,LineStyle)` specifies the line style, marker symbol, and color.

`stem3(__,Name,Value)` specifies stemseries properties using one or more *Name,Value* pair arguments.

`stem3(axes_handle, __)` plots into the axes specified by *axes\_handle* instead of into the current axes (*gca*). The option, *axes\_handle*, can precede any of the input argument combinations in the previous syntaxes.

## Input Arguments

`h = stem3( ___ )` returns the stemseries handle `h`.

### **Z - Data sequence to display**

vector or matrix

Data sequence to display, specified as a vector or matrix. `stem3` plots each element in `Z` as a stem extending from the  $xy$ -plane and terminating at the data value.

- If `Z` is a row vector, `stem3` plots all elements against the same  $y$  value at equally spaced  $x$  values.
- If `Z` is a column vector, `stem3` plots all elements against the same  $x$  value at equally spaced  $y$  values.
- If `Z` is a matrix, `stem3` plots each row of `Z` against the same  $y$  value at equally spaced  $x$  values.

### **Data Types**

single | double | int8 | int16 | int32 | int64 | uint8 |  
uint16 | uint32 | uint64 | logical

### **X - Locations to plot values of Z**

vector or matrix

Locations to plot values of `Z`, specified as a vector or a matrix. Inputs `X`, `Y` and `Z` must be vectors or matrices of the same size.

### **Data Types**

single | double | int8 | int16 | int32 | int64 | uint8 |  
uint16 | uint32 | uint64 | logical

### **Y - Locations to plot values of Z**

vector or matrix

Locations to plot values of `Z`, specified as a vector or a matrix. Inputs `X`, `Y` and `Z` must be vectors or matrices of the same size.

### **Data Types**

single | double | int8 | int16 | int32 | int64 | uint8 |  
uint16 | uint32 | uint64 | logical

**LineStyle - Line style, marker symbol, and color**

string

Line style, marker symbol, and color, specified as a string. For more information on line style, marker symbol, and color options see `LineStyle`.

**Example:** `':*r'`

**Data Types**

char

**axes\_handle - Axes handle**

handle

Axes handle, which is the reference to an axes object. Use the `gca` function to get the handle to the current axes, for example, `axes_handle = gca;`

**Name-Value Pair Arguments**

Specify optional comma-separated pairs of `Name`, `Value` arguments. `Name` is the argument name and `Value` is the corresponding value. `Name` must appear inside single quotes ( `' '` ). You can specify several name and value pair arguments in any order as `Name1,Value1,...,NameN,ValueN`.

**Example:** `'LineStyle',':', 'MarkerFaceColor','red'` plots the stem as a dotted line and sets the marker face color to red.

For more information on these properties see `stemseries`.

**'LineStyle' - Line style**

`'-'` (default) | `'--'` | `':'` | `'-.'` | `'none'`

Line style, specified as the comma-separated pair consisting of `'LineStyle'` and a line style specifier. This table lists supported line styles.

Specifier	Line Style
'-'	Solid line (default)
'--'	Dashed line
':'	Dotted line
'-.'	Dash-dot line
'none'	No line

**Example:** 'LineStyle','-.'

### 'LineWidth' - Line width

0.5 (default) | scalar

Line width, specified as the comma-separated pair consisting of 'LineWidth' and a scalar. The scalar sets the width size in points of the stem and marker edge.

**Example:** 'LineWidth',0.75

### 'Color' - Color

[0 0 1] (blue) (default) | three-element RGB vector | string

Color, specified as the comma-separated pair consisting of 'Color' and a three-element RGB vector or a string containing the short or long name of the color. The RGB vector is a three-element row vector whose elements specify the intensities of the red, green, and blue components of the color. The intensities must be in the range [0 1].

This table lists the predefined colors and their RGB equivalents.

RGB Vector	Short Name	Long Name
[1 1 0]	'y'	'yellow'
[1 0 1]	'm'	'magenta'

RGB Vector	Short Name	Long Name
[0 1 1]	'c'	'cyan'
[1 0 0]	'r'	'red'
[0 1 0]	'g'	'green'
[0 0 1]	'b'	'blue'
[1 1 1]	'w'	'white'
[0 0 0]	'k'	'black'

**Example:** 'Color', [0 1 0]

**Example:** 'Color', 'green'

**Example:** 'Color', 'g'

### 'Marker' - Marker symbol

'o' (default) | string

Marker symbol, specified as the comma-separated pair consisting of 'Marker' and a marker specifier. This table lists supported marker symbols.

Specifier	Marker Symbol
'o'	Circle
'+'	Plus sign
'*'	Asterisk
'.'	Point
'x'	Cross
'square' or 's'	Square
'diamond' or 'd'	Diamond
'^'	Upward-pointing triangle

Specifier	Marker Symbol
'v'	Downward-pointing triangle
'>'	Right-pointing triangle
'<'	Left-pointing triangle
'pentagram' or 'p'	Five-pointed star (pentagram)
'hexagram' or 'h'	Six-pointed star (hexagram)
'none'	No marker

**Example:** 'Marker', '+'

**Example:** 'Marker', 'diamond'

### 'MarkerEdgeColor' - Marker edge color

'auto' (default) | 'none' | three-element RGB vector | string

Marker edge color, specified as the comma-separated pair consisting of 'MarkerEdgeColor' and a color value. The color value can be one of the supported strings or an RGB vector, listed in the following tables.

Specifier	Result
'auto'	Uses same color as line color
'none'	Specifies no color, which makes unfilled markers invisible

For an RGB vector, use a three-element row vector whose elements specify the intensities of the red, green, and blue components of the color. The intensities must be in the range [0 1]. This table lists the predefined string colors and their RGB equivalents.

RGB Vector	Short Name	Long Name
[1 1 0]	'y'	'yellow'
[1 0 1]	'm'	'magenta'

RGB Vector	Short Name	Long Name
[0 1 1]	'c'	'cyan'
[1 0 0]	'r'	'red'
[0 1 0]	'g'	'green'
[0 0 1]	'b'	'blue'
[1 1 1]	'w'	'white'
[0 0 0]	'k'	'black'

**Example:** 'MarkerEdgeColor',[1 .8 .1]

### 'MarkerFaceColor' - Marker face color

'none' (default) | 'auto' | three-element RGB vector | string

Marker face color, specified as the comma-separated pair consisting of 'MarkerFaceColor' and a color value. MarkerFaceColor sets the fill color for markers that are closed shapes (circle, square, diamond, pentagram, hexagram, and the four triangles). The color value can be one of the supported strings or an RGB vector, listed in the following tables.

Specifier	Result
'auto'	Uses same color as marker edge color
'none'	Makes the interior of the marker transparent, allowing the background to show through (default)

For an RGB vector, use a three-element row vector whose elements specify the intensities of the red, green, and blue components of the color. The intensities must be in the range [0 1]. This table lists the predefined string colors and their RGB equivalents.

# stem3

RGB Vector	Short Name	Long Name
[1 1 0]	'y'	'yellow'
[1 0 1]	'm'	'magenta'
[0 1 1]	'c'	'cyan'
[1 0 0]	'r'	'red'
[0 1 0]	'g'	'green'
[0 0 1]	'b'	'blue'
[1 1 1]	'w'	'white'
[0 0 0]	'k'	'black'

**Example:** 'MarkerFaceColor',[0 .8 1]

## 'MarkerSize' - Marker size

6 (default) | scalar

Marker size, specified as the comma-separated pair consisting of 'MarkerSize' and a scalar in points.

**Example:** 'Markersize',12

## Output Arguments

### h - Stemseries object handle

scalar

Stemseries object handle, specified as a scalar. This is a unique identifier, which you can use to query and modify the properties of the stemseries.

## Examples

### Row Vector Input

Create a 3-D stem plot of cosine values between  $-\pi/2$  and  $\pi/2$  with a row vector input.

```
figure
X = linspace(-pi/2,pi/2,40);
Z = cos(X);
```



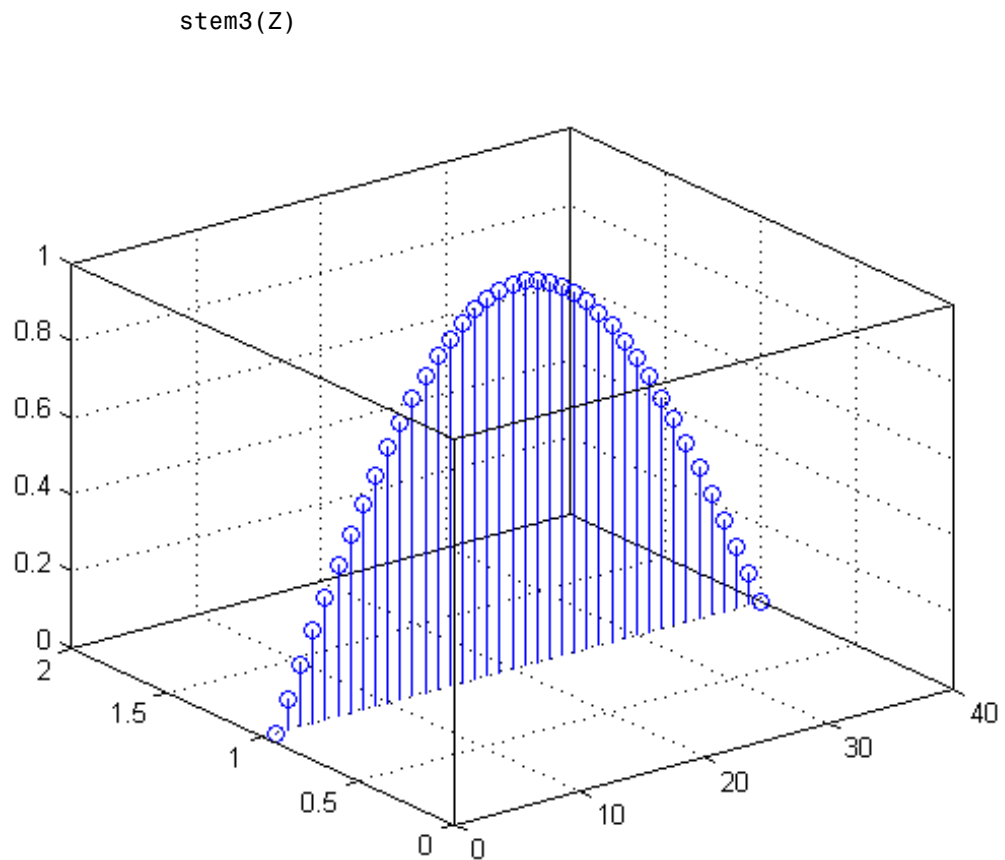

stem3 plots elements of Z against the same y value at equally space x values.

### Column Vector Input

Create a 3-D stem plot of cosine values between  $-\pi/2$  and  $\pi/2$  with a column vector input.

figure

## stem3

```
X = linspace(-pi/2,pi/2,40)';
Z = cos(X);
stem3(Z)
```

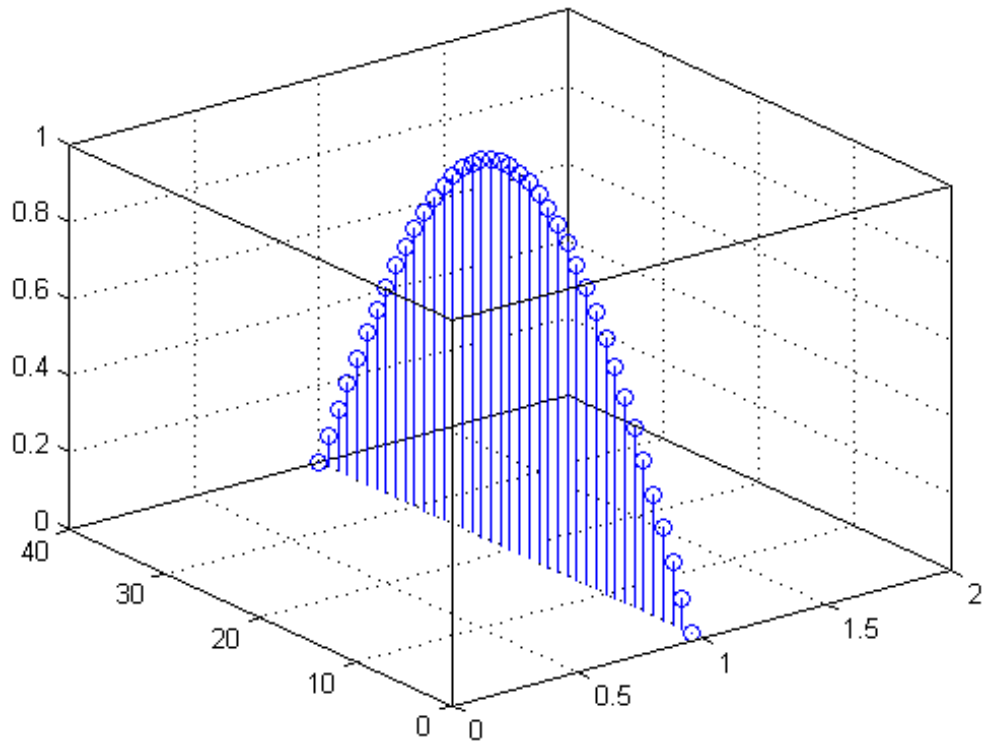

stem3 plots elements of Z against the same x value at equally spaced y values.

### Matrix Input

Create a 3-D stem plot of sine and cosine values between  $-\pi/2$  and  $\pi/2$  with a matrix input.

```
figure
X = linspace(-pi/2,pi/2,40);
Z = [sin(X); cos(X)];
stem3(Z)
```

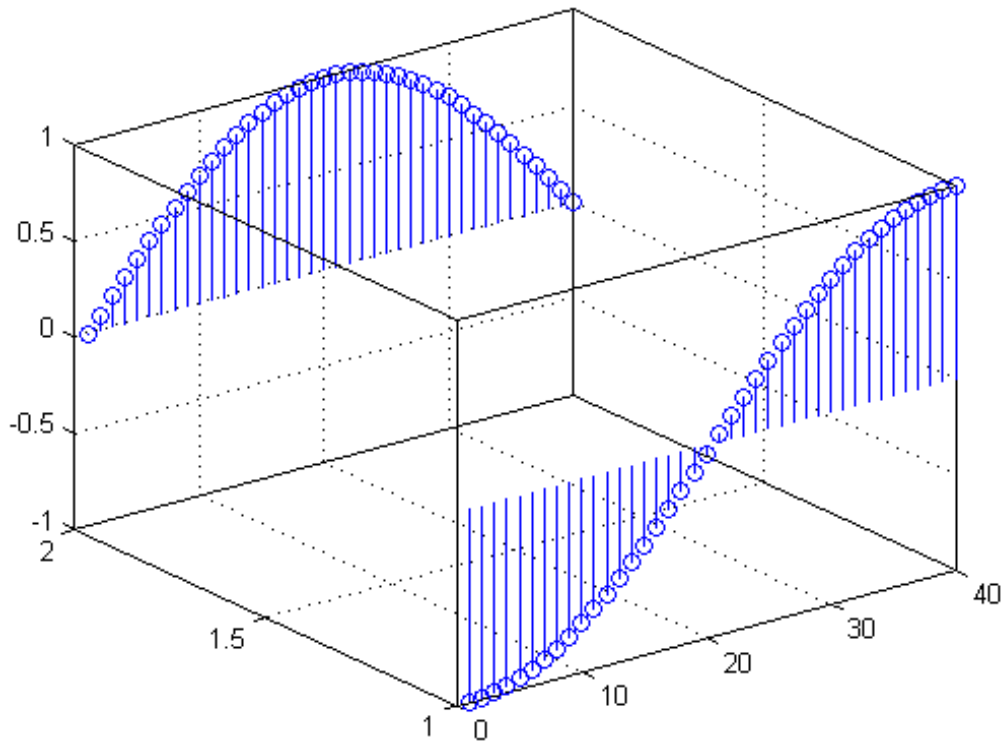

## stem3

---

`stem3` plots each row of  $Z$  against the same  $y$  value at equally spaced  $x$  values.

### **Specify Stem Locations with Vector Inputs**

Create a 3-D stem plot and specify the stem locations along a curve. Use `view` to adjust the angle of the axes in the figure.

```
figure
X = linspace(-5,5,60);
Y = cos(X);
Z = X.^2;
stem3(X,Y,Z)
view(-8,30)
```

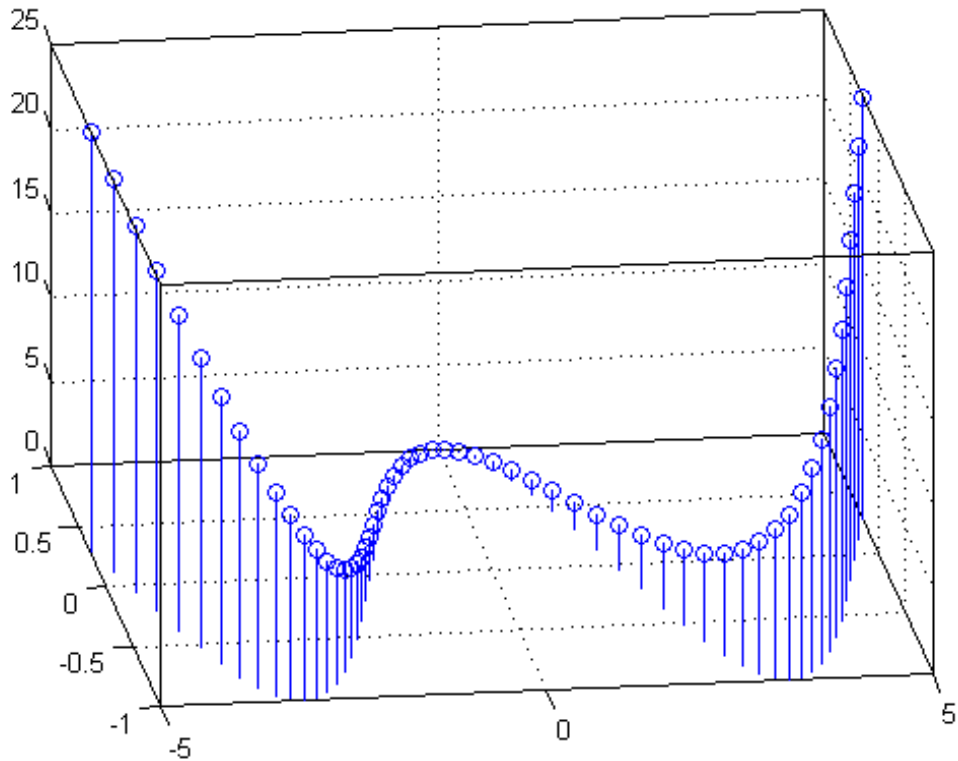

X and Y determine the stem locations. Z determines the marker heights.

### Specify Stem Locations with Matrix Inputs

Create a 3-D stem plot with matrix data and specify the stem locations in the  $xy$ -plane.

```
figure
[X,Y] = meshgrid(0:.1:1);
Z = exp(X+Y);
stem3(X,Y,Z)
```

## stem3

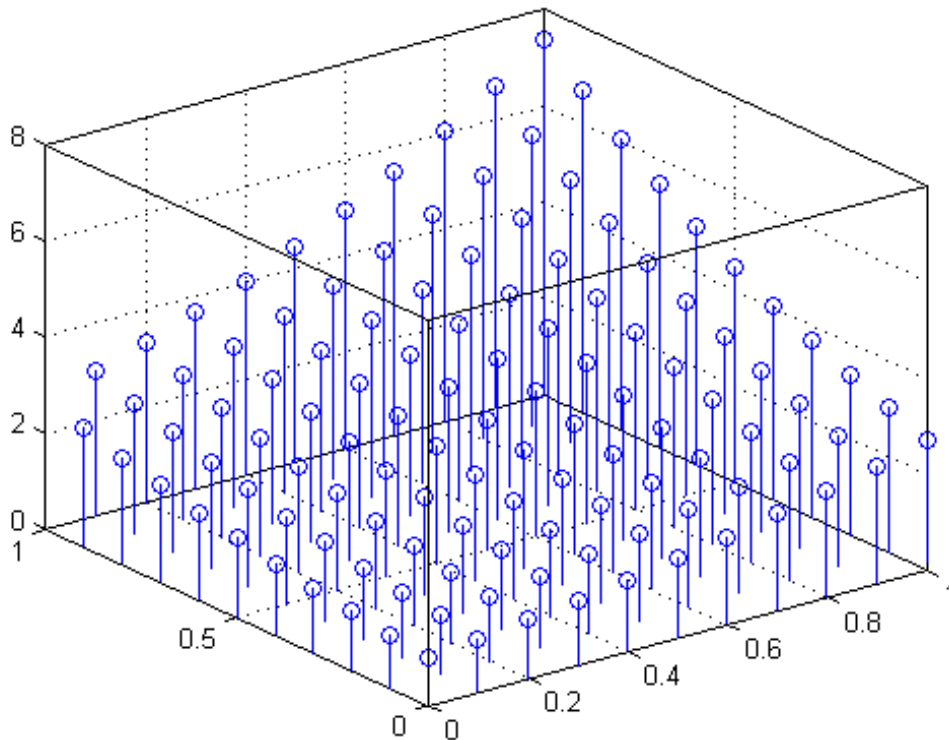

X and Y determine the stem locations. Z determines the marker heights.

### Fill in the Markers

Create a 3-D stem plot of cosine values between  $-\pi$  and  $\pi$ . Use 'fill' to fill in the markers.

```
figure
X = linspace(-pi,pi,40);
Z = cos(X);
```

```
stem3(Z,'fill')
```

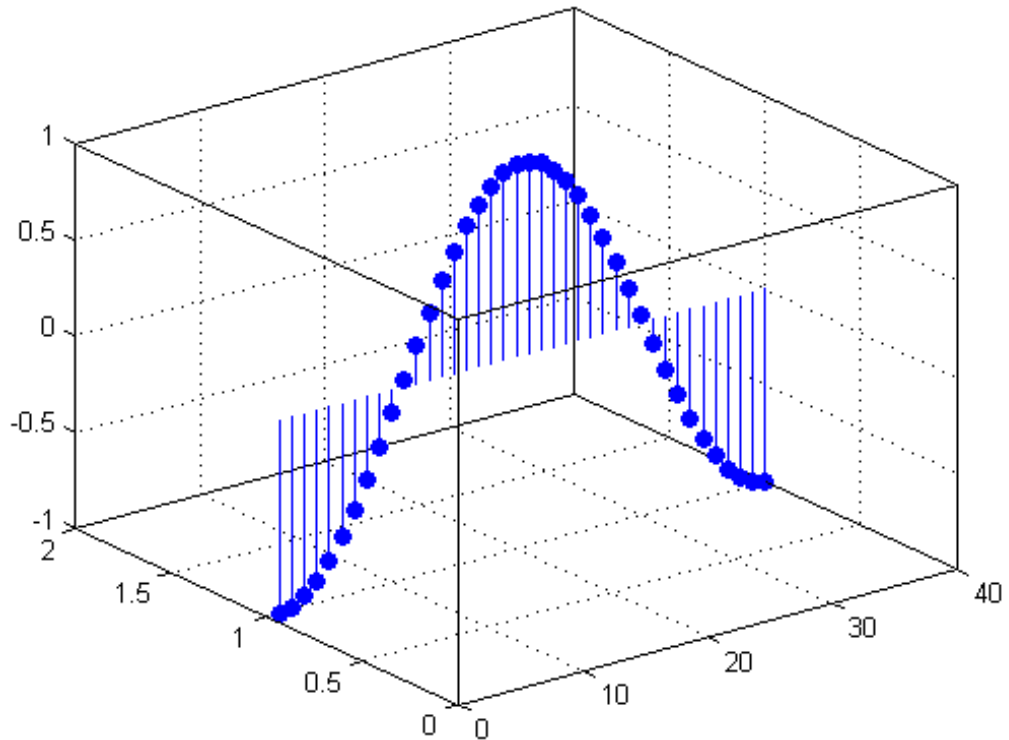

### Line Style, Marker Symbol, and Color Options

Create a 3-D stem plot of cosine values between  $-\pi$  and  $\pi$ . Use a dashed line style for the stem, set the marker symbols to stars, and set the color to magenta.

```
figure
X = linspace(-pi,pi,40);
```

## stem3

```
Z = cos(X);
stem3(Z, '--*m')
```

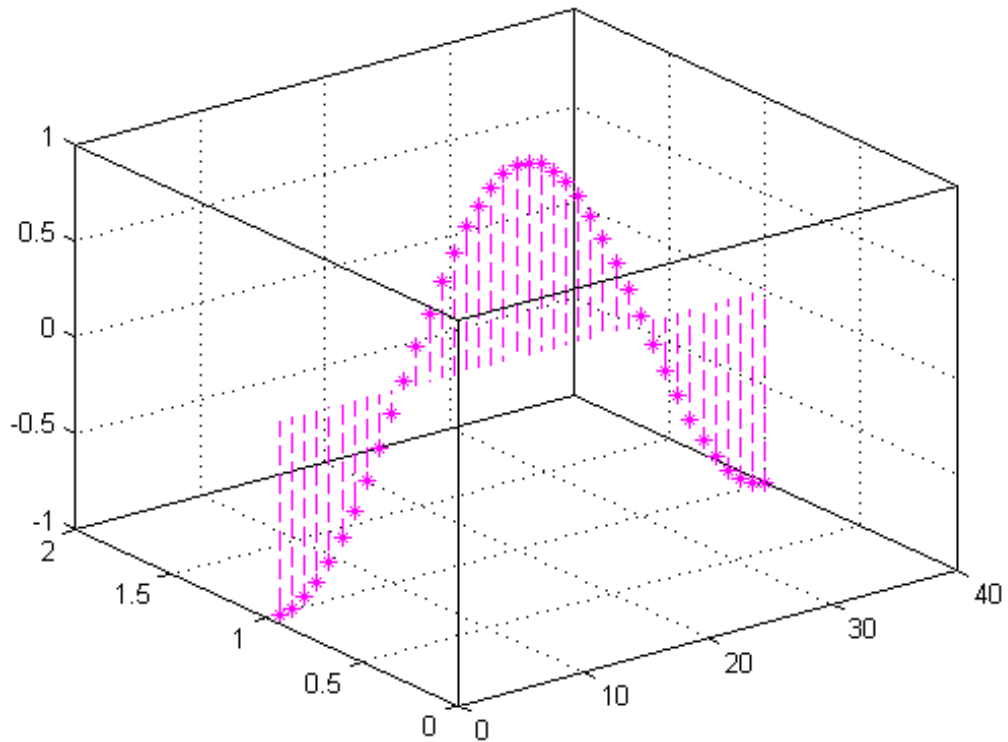

To specify only two of the three LineSpec options, omit the third option from the string. For example, '\*m' sets the marker symbol and the color and uses the default line style.



### Line Style, Marker Symbol, and Color Options

Create a 3-D stem plot and specify the stem locations along a circle. Set the stem to a dotted line style, the marker symbols to stars, and the color to magenta.

```
figure
theta = linspace(0,2*pi);
X = cos(theta);
Y = sin(theta);
Z = theta;
stem3(X,Y,Z,':*m')
```

## stem3

---

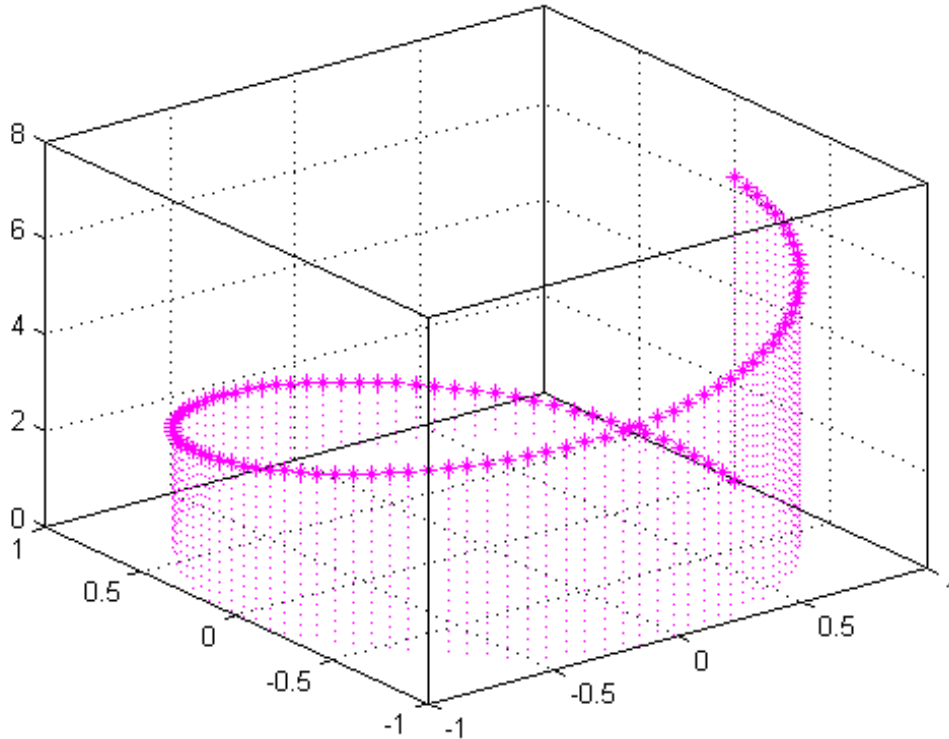

X and Y determine the stem locations. Z determines the marker heights.

### Additional Style Options

Create a 3-D stem plot of cosine values between  $-\pi$  and  $\pi$ . Set the marker symbols to squares with green faces and magenta edges.

```
figure
X = linspace(-pi,pi,40);
Z = cos(X);
stem3(Z,'Marker','s',...
```

```
'MarkerEdgeColor','m',...
'MarkerFaceColor','g')
```

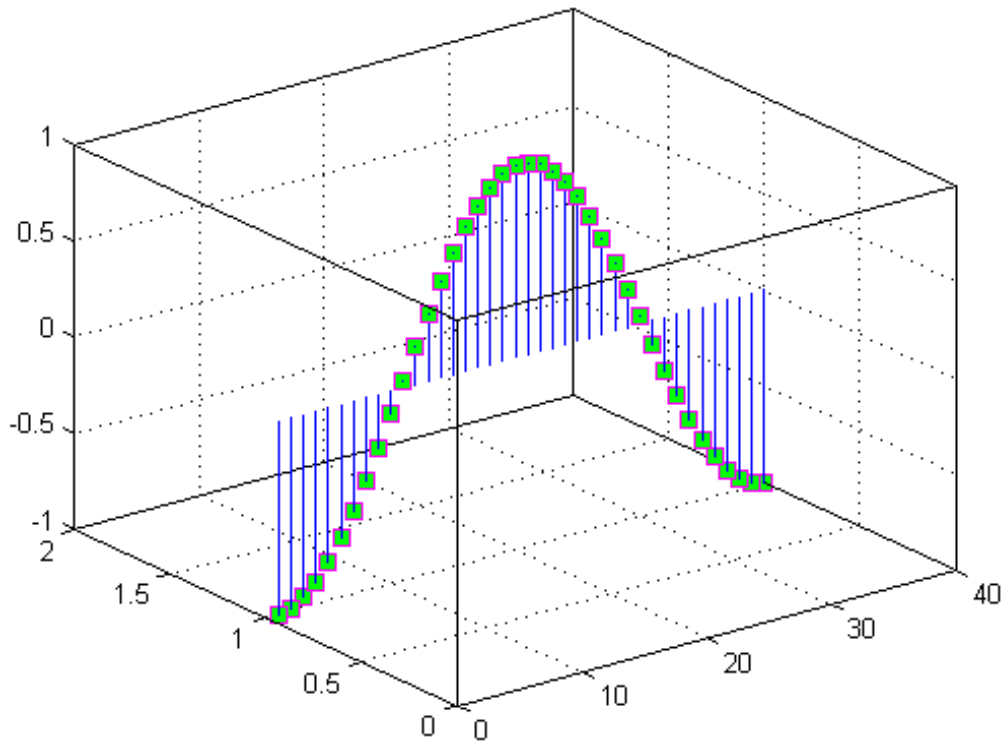

### Axes Handles

Specify the axes for a 3-D stem plot.

Define vectors X, Y and Z.

```
X = linspace(-2,2,50);
```

## stem3

---

```
Y = X.^3;
Z = exp(X);
```

Create a figure with two subplots and return the handles to each axes, `s(1)` and `s(2)`. Plot a 3-D stem plot in the lower subplot by referring to its axes handle, `s(2)`. For comparison, plot a 2-D stem plot in the upper subplot by referring to its axes handle, `s(1)`.

```
figure
s(1) = subplot(2,1,1);
s(2) = subplot(2,1,2);

stem(s(1),X,Z)
stem3(s(2),X,Y,Z)
```

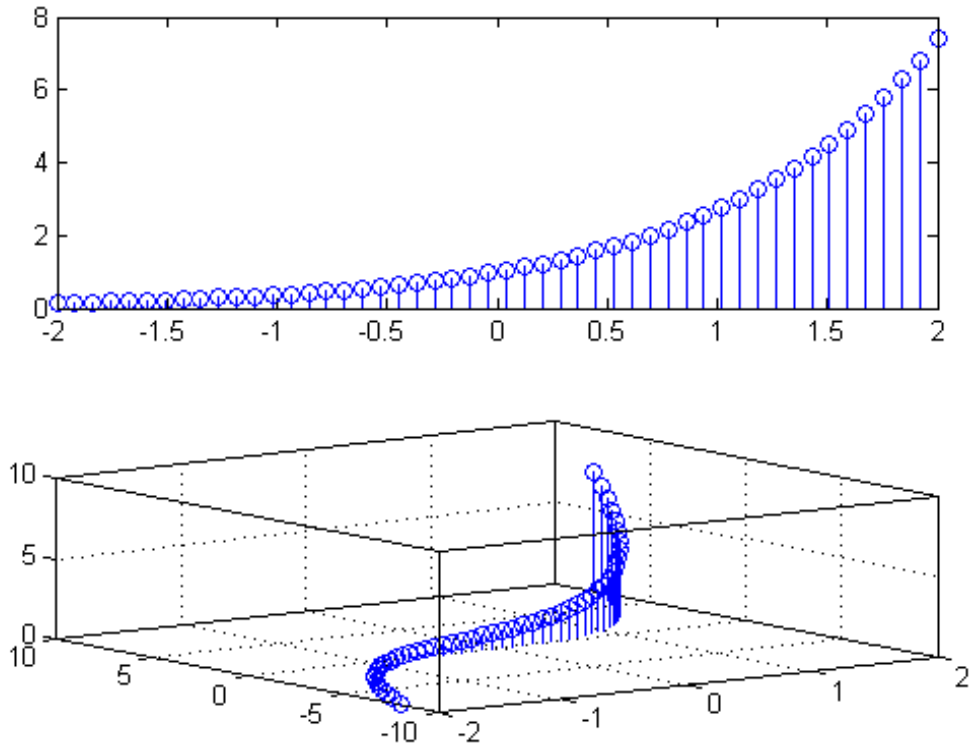

### Stemseries Handle

Create a 3-D stem plot and use the stemseries handle to adjust properties of the plot.

Get the handle for the stemseries.

```
figure
X = linspace(0,2);
Y = X.^3;
```

## stem3

```
Z = exp(X).*cos(Y);
h = stem3(X,Y,Z,'fill');
```

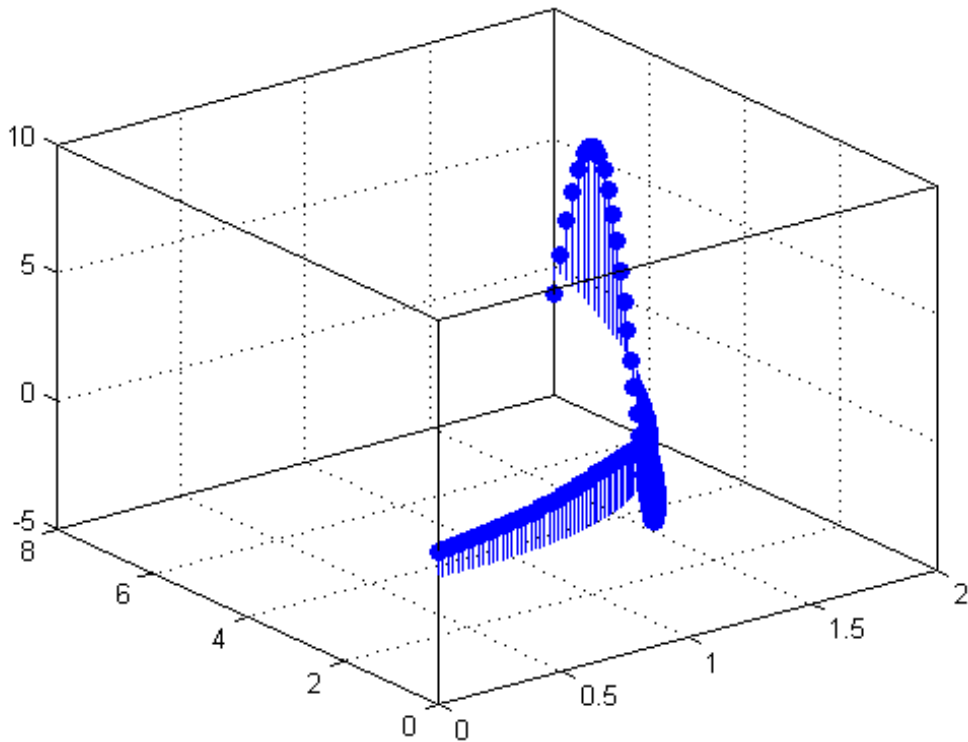

Set the color to magenta and the marker face color to yellow. Use `view` to adjust the angle of the axes in the figure.

```
set(h,'Color','m','MarkerFaceColor','y');
view(-10,35)
```

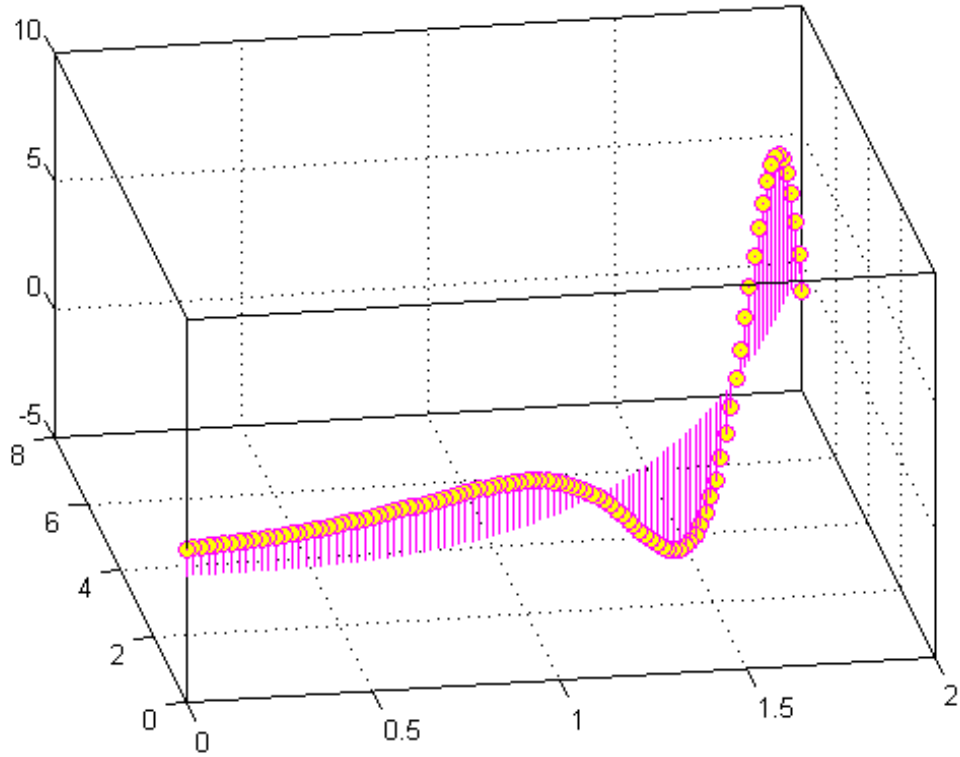
**See Also**

[bar](#) | [plot](#) | [stairs](#) | [stem](#) | [Stemseries Properties](#) |

**Related Examples**

- “Combine Stem Plot and Line Plot”

# Stemseries Properties

---

## Purpose

Define stemseries properties

## Modifying Properties

You can set and query graphics object properties using the `set` and `get` commands or with the property editor (`propertyeditor`).

Note that you cannot define default properties for stemseries objects.

See Plot Objects for information on stemseries objects.

## Stemseries Property Descriptions

This section provides a description of properties. Curly braces { } enclose default values.

### Annotation

`hg.Annotation` object (read-only)

*Control the display of stemseries objects in legends.* Specifies whether this stemseries object is represented in a figure legend.

Querying the `Annotation` property returns the handle of an `hg.Annotation` object. The `hg.Annotation` object has a property called `LegendInformation`, which contains an `hg.LegendEntry` object.

Once you have obtained the `hg.LegendEntry` object, you can set its `IconDisplayStyle` property to control whether the stemseries object is displayed in a figure legend.

IconDisplayStyle Value	Purpose
on	Include the stemseries object in a legend as one entry, but not its children objects
off	Do not include the stemseries or its children in a legend (default)
children	Include only the children of the stemseries as separate entries in the legend



## Setting the IconDisplayStyle Property

These commands set the `IconDisplayStyle` of a graphics object with handle `hobj` to `children`, which causes each child object to have an entry in the legend:

```
hAnnotation = get(hobj, 'Annotation');
hLegendEntry = get(hAnnotation, 'LegendInformation');
set(hLegendEntry, 'IconDisplayStyle', 'children')
```

## Using the IconDisplayStyle Property

See “Control Legend Content” for more information and examples.

### BaseLine

handle

*Handle of the baseline object.* Handle of the line object used as the baseline. Set the properties of this line using its handle.

The following example makes the stem plot baseline a dashed, red line:

```
% Create stem plot
stem_handle = stem(randn(10,1));
% Obtain handle of baseline from stemseries object
baseline_handle = get(stem_handle, 'BaseLine');
% Set line properties
set(baseline_handle, 'LineStyle', '- -', 'Color', 'red')
```

### BaseValue

y-axis value

*Y-axis value where baseline is drawn.* Specify the value along the y-axis at which the MATLAB software draws the baseline.

### BeingDeleted

on | {off} (read-only)

# Stemseries Properties

---

*This object is being deleted.* Mechanism to determine if objects are in the process of being deleted. MATLAB sets the `BeingDeleted` property to `on` when the object's delete function callback is called (see the `DeleteFcn` property). It remains set to `on` while the delete function executes, after which the object no longer exists.

For example, an object's delete function calls other functions that act on a number of different objects. If a function does not need to perform an action on an about-be-deleted object, it can check the object's `BeingDeleted` property before acting.

`BusyAction`  
cancel | {queue}

## *Callback queuing*

Determines how MATLAB handles the execution of interrupting callbacks.

A *running* callback is the currently executing callback. The *interrupting* callback is the callback that tries to interrupt the *running* callback. The `BusyAction` property of the *interrupting* callback determines how MATLAB handles its execution. When the `BusyAction` property is set to:

- 'queue' — Puts the *interrupting* callback in a queue to be processed after the *running* callback finishes execution.
- 'cancel' — Discards the *interrupting* callback as MATLAB finishes execution.

For information about how the `Interruptible` property of the callback controls whether other callbacks can interrupt the *running* callback, see the `Interruptible` property description.

`ButtonDownFcn`  
string | function handle

*Button press callback function.* Executes whenever you press a mouse button while the pointer is over this object, but not over another graphics object. See the `HitTestArea` property for information about selecting objects of this type.

See the figure's `SelectionType` property to determine if modifier keys were also pressed.

This property can be:

- A string that is a valid MATLAB expression
- The name of a MATLAB file
- A function handle

Set this property to a function handle that references the callback. The expressions execute in the MATLAB workspace.

For information on the syntax of callback functions, see [Function Handle Callbacks](#).

## Children

array of graphics object handles

*Children of the stemseries object.* An array containing the handles of all line objects parented to the stemseries object (whether visible or not).

If a child object's `HandleVisibility` property is `callback` or `off`, its handle does not show up in this object's `Children` property. If you want the handle in the `Children` property, set the root `ShowHiddenHandles` property to `on`. For example:

```
set(0, 'ShowHiddenHandles', 'on')
```

## Clipping

{on} | off

# Stemseries Properties

---

*Clipping mode.* MATLAB clips graphs to the axes plot box by default. If you set `Clipping` to `off`, portions of graphs appear outside the axes plot box. This occurs if you create a plot object, set `hold` to `on`, freeze axis scaling (`axis manual`), and then create a larger plot object.

## Color

`ColorSpec`

*Color of stem lines.* A three-element RGB vector or one of the MATLAB predefined names, specifying the line color. See the `ColorSpec` reference page for more information on specifying color.

For example, the following statement creates a stem plot with red lines.

```
h = stem(randn(10,1),'Color','r');
```

## CreateFcn

function handle | cell array containing function handle and additional arguments | string (not recommended)

*Callback function executed during object creation.* Defines a callback that executes when MATLAB creates an object. The default is an empty array.

You must specify the callback during the creation of the object. For example:

```
graphicfcn(y,'CreateFcn',@CallbackFcn)
```

where `@CallbackFcn` is a function handle that references the callback function and `graphicfcn` is the plotting function which creates this object.

MATLAB executes this routine after setting all other object properties. Setting this property on an existing object has no effect.

The handle of the object whose `CreateFcn` is being executed is accessible only through the root `CallbackObject` property, which you can query using `gcbo`.

For information on the syntax of callback functions, see [Function Handle Callbacks](#).

## DeleteFcn

function handle | cell array containing function handle and additional arguments | string (not recommended)

*Callback executed during object deletion.* Executes when this object is deleted (for example, this might happen when you issue a `delete` command on the object, its parent axes, or the figure containing it). MATLAB executes the callback before destroying the object's properties so the callback routine can query these values. The default is an empty array.

The handle of the object whose `DeleteFcn` is being executed is accessible only through the root `CallbackObject` property, which can be queried using `gcbo`.

For information on the syntax of callback functions, see [Function Handle Callbacks](#).

See the `BeingDeleted` property for related information.

## DisplayName

string

*String used by legend.* The `legend` function uses the `DisplayName` property to label the stemseries object in the legend. The default is an empty string.

# Stemseries Properties

---

- If you specify string arguments with the `legend` function, MATLAB set `DisplayName` to the corresponding string and uses that string for the legend.
- If `DisplayName` is empty, `legend` creates a string of the form, `['data' n]`, where `n` is the number assigned to the object based on its location in the list of legend entries. However, `legend` does not set `DisplayName` to this string.
- If you edit the string directly in an existing legend, MATLAB set `DisplayName` to the edited string.
- If you specify a string for the `DisplayName` property and create the legend using the figure toolbar, then MATLAB uses the string defined by `DisplayName`.
- To add a legend programmatically that uses the `DisplayName` string, call `legend` with the `toggle` or `show` option.

See “Control Legend Content” for more information and examples.

## EraseMode

`{normal} | none | xor | background`

*Erase mode.* Controls the technique MATLAB uses to draw and erase objects. Use alternative erase modes for creating animated sequences, where control of the way individual objects are redrawn is necessary to improve performance and obtain the desired effect.

- `normal` — Redraw the affected region of the display, performing the three-dimensional analysis necessary to correctly render all objects. This mode produces the most accurate picture, but is the slowest. The other modes are faster, but do not perform a complete redraw and are therefore less accurate.
- `none` — Do not erase the object when it is moved or destroyed. While the object is still visible on the screen after erasing with `EraseMode none`, you cannot print it because MATLAB stores no information about its former location.

- `xor` — Draw and erase the object by performing an exclusive OR (XOR) with the color of the screen beneath it. This mode does not damage the color of the objects beneath it. However, the object's color depends on the color of whatever is beneath it on the display.
- `background` — Erase the object by redrawing it in the axes background `Color`, or the figure background `Color` if the axes `Color` property is `none`. This damages objects that are behind the erased object, but properly colors the erased object.

Set the axes background color with the axes `Color` property. Set the figure background color with the figure `Color` property.

## Printing with Nonnormal Erase Modes

MATLAB always prints figures as if the `EraseMode` of all objects is `normal`. This means graphics objects created with `EraseMode` set to `none`, `xor`, or `background` can look different on screen than on paper. On screen, MATLAB mathematically combines layers of colors (for example, performing an XOR on a pixel color with that of the pixel behind it) and ignore three-dimensional sorting to obtain greater rendering speed. However, these techniques are not applied to the printed output.

You can use the `getframe` command or other screen capture applications to create an image of a figure containing nonnormal mode objects.

## `HandleVisibility`

`{on} | callback | off`

*Control access to object's handle.* Determines when an object's handle is visible in its parent's list of children. `HandleVisibility` is useful for preventing command-line users from accidentally accessing objects that you need to protect for some reason.

- `on` — Handles are always visible.

# Stemseries Properties

---

- **callback** — Handles are visible from within callback routines or functions invoked by callback routines, but not from within functions invoked from the command line. This provides a means to protect GUIs from command-line users, while allowing callback routines to have access to object handles.
- **off** — Handles are invisible at all times. Use this option when a callback invokes a function that could damage the GUI (such as evaluating a user-typed string). This option temporarily hides its own handles during the execution of that function.

## Functions Affected by Handle Visibility

When a handle is not visible in its parent's list of children, it cannot be returned by functions that obtain handles by searching the object hierarchy or querying handle properties. This includes `get`, `findobj`, `gca`, `gcf`, `gco`, `newplot`, `cla`, `clf`, and `close`.

## Properties Affected by Handle Visibility

When a handle's visibility is restricted using `callback` or `off`, the object's handle does not appear in its parent's `Children` property, figures do not appear in the root's `CurrentFigure` property, objects do not appear in the root's `CallbackObject` property or in the figure's `CurrentObject` property, and axes do not appear in their parent's `CurrentAxes` property.

## Overriding Handle Visibility

You can set the root `ShowHiddenHandles` property to `on` to make all handles visible regardless of their `HandleVisibility` settings. This does not affect the values of the `HandleVisibility` properties. See also `findall`.

## Handle Validity



Hidden handles are still valid. If you know an object's handle, you can `set` and `get` its properties and pass it to any function that operates on handles.

---

**Note** If you change one data source property to a variable that contains data of a different dimension, you might cause the function to generate a warning and not render the graph until you have changed all data source properties to appropriate values.

---

## HitTest

`{on}` | `off`

*Selectable by mouse click.* Determines whether this object can become the current object (as returned by the `gco` command and the figure `CurrentObject` property) as a result of a mouse click on the line objects that compose the stem plot. If `HitTest` is `off`, clicking this object selects the object below it (which is usually the axes containing it).

## HitTestArea

`on` | `{off}`

*Select the object by clicking stem lines or area of extent.* Select plot objects by:

- Clicking stem lines (default).
- Clicking anywhere in the extent of the plot.

When `HitTestArea` is `off`, you must click the stem lines to select the object. When `HitTestArea` is `on`, you can select this object by clicking anywhere within the extent of the plot (that is, anywhere within a rectangle that encloses all the stem lines).

## Interruptible

`off` | `{on}`

# Stemseries Properties

---

## *Callback routine interruption*

Controls whether MATLAB can interrupt an object's callback function when subsequent callbacks attempt to interrupt it.

For Graphics objects, the `Interruptible` property affects only the callbacks for the `ButtonDownFcn` property. A *running* callback is the currently executing callback. The *interrupting* callback is the callback that tries to interrupt the *running* callback. MATLAB handles both the callbacks based on the `Interruptible` property of the object of the *running* callback.

When the `Interruptible` property is set to:

- 'off', MATLAB finishes execution of the *running* callback without any interruptions
- 'on', these conditions apply:
  - If there is a `drawnow`, `figure`, `getframe`, `waitfor`, or `pause` command in the *running* callback, then MATLAB executes the *interrupting* callbacks which are already in the queue and returns to finish execution of the current callback.
  - If one of the above functions is not in the *running* callback, then MATLAB finishes execution of the current callback without any interruption.

`BusyAction` property of the object of interrupting callback determines whether the callback should be ignored or should be put in the queue.

Setting `Interruptible` property to on (default), allows a callback from other graphics objects to interrupt callback functions originating from this object.

---

**Note** MATLAB does not save the state of properties or the display when an interruption occurs. For example, the handle returned by the `gca` or `gcf` command may be changed as another callback is executed.

---

After the function that interrupts a callback completes, the callback resumes execution where it halted when interrupted. For more information, see “Control Callback Execution and Interruption”.

**LineStyle**

{-} | -- | : | -. | none

*Line style of stemseries object.*

## Line Style Specifiers Table

Specifier	Line Style
'-'	Solid line (default)
'--'	Dashed line
':'	Dotted line
'-.'	Dash-dot line
'none'	No line

Use **LineStyle** `none` when you want to place a marker at each point but do not want the points connected with a line (see the **Marker** property).

**LineWidth**

size in points

*Width of linear objects and edges of filled areas. Specify in points. 1 point =  $1/72$  inch. The default is 0.5 points.*

# Stemseries Properties

---

## Marker

character (see table)

*Marker symbol.* Specifies marks that display at data points. You can set values for the Marker property independently from the LineStyle property. For a list of supported marker symbols, see the following table.

### Marker Specifiers Table

Specifier	Marker Type
'+'	Plus sign
'o'	Circle
'*'	Asterisk
'.'	Point
'x'	Cross
'square' or 's'	Square
'diamond' or 'd'	Diamond
'^'	Upward-pointing triangle
'v'	Downward-pointing triangle
'>'	Right-pointing triangle
'<'	Left-pointing triangle
'pentagram' or 'p'	Five-pointed star (pentagram)
'hexagram' or 'h' ' '	Six-pointed star (hexagram)
'none'	No marker (default)

## MarkerEdgeColor

ColorSpec | none | {auto}

*Marker edge color.* The color of the marker or the edge color for filled markers (circle, square, diamond, pentagram, hexagram, and the four triangles).

- `ColorSpec` — User-defined color.
- `none` — Specifies no color, which makes nonfilled markers invisible.
- `auto` — Uses same color as the `Color` property.

`MarkerFaceColor`

`ColorSpec` | `{none}` | `auto`

*Fill color for closed-shape markers.* The fill color for markers that are closed shapes (circle, square, diamond, pentagram, hexagram, and the four triangles).

- `ColorSpec` — User-defined color.
- `none` — Makes the interior of the marker transparent, allowing the background to show through.
- `auto` — Sets the fill color to the axes `Color` property. If the axes `Color` property is `none`, sets the fill color to the figure `Color`.

`MarkerSize`

scalar

*Marker size.* Size of the marker in points. The default value is 6.

---

**Note** MATLAB draws the point marker (specified by the `'.'` symbol) at one-third the specified size.

---

`Parent`

handle of parent axes, `hgggroup`, or `hgtransform`

# Stemseries Properties

---

*Parent of object.* Handle of the object's parent. The parent is normally the axes, hggroup, or hgtransform object that contains the object.

Selected

on | {off}

*Object selection state.* When you set this property to on, MATLAB displays selection handles at the corners and midpoints if the SelectionHighlight property is also on (the default). You can, for example, define the ButtonDownFcn callback to set this property to on, thereby indicating that this particular object is selected. This property is also set to on when an object is manually selected in plot edit mode.

SelectionHighlight

{on} | off

*Object highlighted when selected.*

- on — MATLAB indicates the selected state by drawing four edge handles and four corner handles.
- off — MATLAB does not draw the handles except when in plot edit mode and objects are selected manually.

Tag

string

*User-specified object label.* Provides a means to identify graphics objects with a user-specified label. The default is an empty string.

Use the Tag property and the findobj function to manipulate specific objects within a plotting hierarchy.

For example, create a stemseries object and set the Tag property:

```
Y = linspace(-2*pi,2*pi,10);
t = stem(Y,'Tag','stem1')
```

To access the stemseries object, use `findobj` to find the object's handle. The following statement changes the `MarkerFaceColor` property of the object whose `Tag` is `stem1`.

```
set(findobj('Tag','stem1'),'MarkerFaceColor','red')
```

## Type

string (read-only)

*Type of graphics object.* String that identifies the class of the graphics object. Use this property to find all objects of a given type within a plotting hierarchy. For stemseries objects, `Type` is `'hggroup'`. The following statement finds all `hggroup` objects in the current axes object.

```
t = findobj(gca,'Type','hggroup');
```

## UIContextMenu

handle of `uicontextmenu` object

*Associate context menu with object.* Handle of a `uicontextmenu` object created in the object's parent figure. Use the `uicontextmenu` function to create the context menu. MATLAB displays the context menu whenever you right-click over the object. The default value is an empty array.

## UserData

array

*User-specified data.* Data you want to associate with this object (including cell arrays and structures). The default value is an empty array. MATLAB does not use this data, but you can access it using the `set` and `get` commands.

## Visible

{on} | off

*Visibility of object and its children.*

# Stemseries Properties

---

- **on** — Object and all children of the object are visible unless the child object's `Visible` property is `off`.
- **off** — Object not displayed. However, the object still exists and you can set and query its properties.

## XData

array

*X-axis location of stems.* The stem function draws an individual stem at each *x*-axis location in the XData array. XData can be either a matrix equal in size to YData or a vector equal in length to the number of rows in YData. That is, `length(XData) == size(YData,1)`. XData does not need to be monotonically increasing.

If you do not specify XData (which is the input argument X), the stem function uses the indices of YData to create the stem plot. See the XDataMode property for related information.

## XDataMode

{auto} | manual

*Use automatic or user-specified x-axis values.* If you specify XData (by setting the XData property or specifying the X input argument), MATLAB sets this property to `manual` and uses the specified values to label the *x*-axis.

If you set XDataMode to `auto` after specifying XData, MATLAB resets the *x*-axis ticks to `1:size(YData,1)` or to the column indices of the ZData, overwriting any previous values for XData.

## XDataSource

MATLAB variable, as a string

*Link XData to MATLAB variable.* Set this property to a MATLAB variable that is evaluated in the base workspace to generate the XData. The default value is an empty array.



```
set(h,'XDataSource','xdatavariablename')
```

MATLAB requires a call to `refreshdata` when you set this property. Changing workspace variables used as an object's `XDataSource` does not change the object's `XData` values, but you can use `refreshdata` to force an update of the object's data. `refreshdata` also lets you specify that the data source variable be evaluated in the workspace of a function from which you call `refreshdata`.

---

**Note** If you change one data source property to a variable that contains data of a different dimension, you might cause the function to generate a warning and not render the graph until you have changed all data source properties to appropriate values.

---

## YData

scalar | vector | matrix

*Stem plot data.* `YData` contains the data plotted as stems. Each value in `YData` is represented by a marker in the stem plot. If `YData` is a matrix, MATLAB creates a series of stems for each column in the matrix.

The input argument `Y` in the `stem` function calling syntax assigns values to `YData`.

## YDataSource

MATLAB variable, as a string

*Link YData to MATLAB variable.* Set this property to a MATLAB variable that is evaluated in the base workspace to generate the `YData`. The default value is an empty array.

```
set(h,'YDataSource','Ydatavariablename')
```

# Stemseries Properties

---

MATLAB requires a call to `refreshdata` when you set this property. Changing workspace variables used as an object's `YDataSource` does not change the object's `YData` values, but you can use `refreshdata` to force an update of the object's data. `refreshdata` also lets you specify that the data source variable be evaluated in the workspace of a function from which you call `refreshdata`.

---

**Note** If you change one data source property to a variable that contains data of a different dimension, you might cause the function to generate a warning and not render the graph until you have changed all data source properties to appropriate values.

---

## ZData

vector

*Z-coordinates.* A data defining the stems for 3-D stem graphs. `XData` and `YData` (if specified) must be the same size.

## ZDataSource

MATLAB variable, as a string

*Link ZData to MATLAB variable.* Set this property to a MATLAB variable that is evaluated in the base workspace to generate the `ZData`. The default value is an empty array.

```
set(h, 'ZDataSource', 'zdatavariablename')
```

MATLAB requires a call to `refreshdata` when you set this property. Changing workspace variables used as an object's `ZDataSource` does not change the object's `ZData` values, but you can use `refreshdata` to force an update of the object's data. `refreshdata` also lets you specify that the data source variable be evaluated in the workspace of a function from which you call `refreshdata`.

---

**Note** If you change one data source property to a variable that contains data of a different dimension, you might cause the function to generate a warning and not render the graph until you have changed all data source properties to appropriate values.

---

# stopasync

---

<b>Purpose</b>	Stop asynchronous read and write operations
<b>Syntax</b>	<code>stopasync(obj)</code>
<b>Description</b>	<code>stopasync(obj)</code> stops any asynchronous read or write operation that is in progress for the serial port object, <code>obj</code> .

**Tips** You can write data asynchronously using the `fprintf` or `fwrite` function. You can read data asynchronously using the `readasync` function, or by configuring the `ReadAsyncMode` property to `continuous`. In-progress asynchronous operations are indicated by the `TransferStatus` property.

If `obj` is an array of serial port objects and one of the objects cannot be stopped, the remaining objects in the array are stopped and a warning is returned. After an object stops:

- Its `TransferStatus` property is configured to `idle`.
- Its `ReadAsyncMode` property is configured to `manual`.
- The data in its output buffer is flushed.

Data in the input buffer is not flushed. You can return this data to the MATLAB workspace using any of the synchronous read functions. If you execute the `readasync` function, or configure the `ReadAsyncMode` property to `continuous`, then the new data is appended to the existing data in the input buffer.

**See Also** `fprintf` | `fwrite` | `readasync` | `ReadAsyncMode` | `TransferStatus`

**Purpose** Convert string to double-precision value

**Syntax**  
`X = str2double('str')`  
`X = str2double(C)`

**Description** `X = str2double('str')` converts the string `str`, which should be an ASCII character representation of a real or complex scalar value, to the MATLAB double-precision representation. The string can contain digits, a comma (thousands separator), a decimal point, a leading + or - sign, an `e` preceding a power of 10 scale factor, and an `i` for a complex unit.

If `str` does not represent a valid scalar value, `str2double` returns NaN.

`X = str2double(C)` converts the strings in the cell array of strings `C` to double precision. The matrix `X` returned will be the same size as `C`.

**Examples** Here are some valid `str2double` conversions.

```
str2double('123.45e7')
str2double('123 + 45i')
str2double('3.14159')
str2double('2.7i - 3.14')
str2double({'2.71' '3.1415'})
str2double('1,200.34')
```

**See Also** `char` | `hex2num` | `num2str` | `str2num` | `cast`

# str2func

---

**Purpose** Construct function handle from function name string

**Syntax** `str2func('str')`

**Description** `str2func('str')` constructs a function handle `fhandle` for the function named in the string `'str'`. The contents of `str` can be the name of a file that defines a MATLAB function, or the name of an anonymous function.

You can create a function handle `fh` using any of the following four methods:

- Create a handle to a named function:

```
fh = @functionName;
fh = str2func('functionName');
```

- Create a handle to an anonymous function:

```
fh = @(x)functionDef(x);
fh = str2func('@(x)functionDef(x)');
```

You can create an array of function handles from strings by creating the handles individually with `str2func`, and then storing these handles in a cell array.

**Tips** Nested functions are not accessible to `str2func`. To construct a function handle for a nested function, you must use the function handle constructor, `@`.

Any variables and their values originally stored in a function handle when it was created are lost if you convert the function handle to a string and back again using the `func2str` and `str2func` functions.

## Examples **Example 1**

To convert the string, `'sin'`, into a handle for that function, type

```
fh = str2func('sin')
```

```
fh =
 @sin
```

### Example 2

If you pass a function name string in a variable, the function that receives the variable can convert the function name to a function handle using `str2func`. The example below passes the variable, `funcname`, to function `makeHandle`, which then creates a function handle. Here is the function:

```
function fh = makeHandle(funcname)
fh = str2func(funcname);
```

This is the code that calls `makeHandle` to construct the function handle:

```
makeHandle('sin')
ans =
 @sin
```

### Example 3

To call `str2func` on a cell array of strings, use the `cellfun` function. This returns a cell array of function handles:

```
fh_array = cellfun(@str2func, {'sin' 'cos' 'tan'}, ...
 'UniformOutput', false);
```

```
fh_array{2}(5)
ans =
 0.2837
```

### Example 4

In the following example, the `myminbnd` function expects to receive either a function handle or string in the first argument. If you pass a string, `myminbnd` constructs a function handle from it using `str2func`, and then uses that handle in a call to `fminbnd`:

```
function myminbnd(fhandle, lower, upper)
if ischar(fhandle)
```

```
 disp 'converting function string to function handle ...'
 fhandle = str2func(fhandle);
 end
 fminbnd(fhandle, lower, upper)
```

Whether you call `myminbnd` with a function handle or function name string, the function can handle the argument appropriately:

```
myminbnd('humps', 0.3, 1)
converting function string to function handle ...
ans =
 0.6370
```

## Example 5

The `dirByType` function shown here creates an anonymous function called `dirCheck`. What the anonymous function does depends upon the value of the `dirType` argument passed in to the primary function. The example demonstrates one possible use of `str2func` with anonymous functions:

```
function dirByType(dirType)
 switch(dirType)
 case 'class', leadchar = '@';
 case 'package', leadchar = '+';
 otherwise disp('ERROR: Unrecognized type'), return;
 end

 dirfile = @(fs)isdir(fs.name);
 dirCheckStr = ['@(fs)strcmp(fs.name(1,1),'', leadchar, '')'];
 dirCheckFun = str2func(dirCheckStr);
 s = dir; filecount = length(s);

 for k=1:filecount
 fstruct = s(k);
 if dirfile(fstruct) && dirCheckFun(fstruct)
 fprintf('%s folder: %s\n', dirType, fstruct.name)
 end
 end
end
```



Generate a list of class and package folders:

```
dirByType('class')
class folder: @Point
class folder: @asset
class folder: @bond

dirByType('package')
package folder: +containers
package folder: +event
package folder: +mypkg
```

**See Also**

[function\\_handle](#) | [func2str](#) | [functions](#)

# str2mat

---

**Purpose** Form blank-padded character matrix from strings

---

**Note** str2mat is not recommended. Use char instead.

---

**Syntax** S = str2mat(T1, T2, T3, ...)

**Description** S = str2mat(T1, T2, T3, ...) forms the matrix S containing the text strings T1, T2, T3, ... as rows. The function automatically pads each string with blanks in order to form a valid matrix. Each text parameter, Ti, can itself be a string matrix. This allows the creation of arbitrarily large string matrices. Empty strings are significant.

**Tips** str2mat differs from strvcat in that empty strings produce blank rows in the output. In strvcat, empty strings are ignored.

**Examples** x = str2mat('36842', '39751', '38453', '90307');

```
whos x
 Name Size Bytes Class
 x 4x5 40 char array
```

```
x(2,3)
```

```
ans =
```

```
7
```

**See Also** char

**Purpose** Convert string to number

**Syntax**

```
x = str2num('str')
[x, status] = str2num('str')
```

## Description

---

**Note** str2num uses the eval function to convert the input argument. Side effects can occur if the string contains calls to functions. Using str2double can avoid some of these side effects.

---

`x = str2num('str')` converts the string `str`, which is an ASCII character representation of a numeric value, to numeric representation. `str2num` also converts string matrices to numeric matrices. If the input string does not represent a valid number or matrix, `str2num(str)` returns the empty matrix in `x`.

The input string can contain one or more numbers separated by spaces, commas, or semicolons, such as '5', '10,11,12', or '5,10;15,20'. In addition to numerical values and delimiters, the input string can also include a decimal point, leading + or - signs, the letter e or d preceding a power of 10 scale factor, or the letter i or j indicating a complex or imaginary number.

The following table shows several examples of valid inputs to `str2num`:

String Input	Numeric Output	Output Class
'500'	500	1-by-1 scalar double
'500 250 125 67'	500, 250, 125, 67	1-by-4 row vector of double
'500; 250; 125; 62.5'	500.0000 250.0000 125.0000 62.5000	4-by-1 column vector of double

# str2num

String Input	Numeric Output	Output Class
'1 23 6 21; 53:56'	1 23 6 21 53 54 55 56	2-by-5 matrix of double
'12e-3 5.9e-3'	0.0120 0.0059	vector of double
'uint16(500)'	500	16-bit unsigned integer

---

**Note** `str2num` does not operate on cell arrays. To convert a cell array of strings to a numeric value, use `str2double`.

---

If the input string does not represent a valid number or matrix, `str2num(str)` returns the empty matrix in `x`.

`[x, status] = str2num('str')` returns the status of the conversion in logical `status`, where `status` equals logical 1 (true) if the conversion succeeds, and logical 0 (false) otherwise.

Space characters can be significant. For instance, `str2num('1+2i')` and `str2num('1 + 2i')` produce `x = 1+2i`, while `str2num('1 +2i')` produces `x = [1 2i]`. You can avoid these problems by using the `str2double` function.

## Examples

Input a character string that contains a single number. The output is a scalar double:

```
A = str2num('500')
A =
 500

class(A)
ans =
 double
```

Repeat this operation, but this time using an unsigned 16-bit integer:

```
A = str2num('uint16(500)')
A =
 500

class(A)
ans =
 uint16
```

Try three different ways of specifying a row vector. Each returns the same answer:

```
str2num('2 4 6 8') % Separate with spaces.
ans =
 2 4 6 8

str2num('2,4,6,8') % Separate with commas.
ans =
 2 4 6 8

str2num('[2 4 6 8]') % Enclose in brackets.
ans =
 2 4 6 8
```

Note that the first two of these commands do not need the MATLAB square bracket operator to create a matrix. The `str2num` function inserts the brackets for you if they are needed.

Use a column vector this time:

```
str2num('2; 4; 6; 8')
ans =
 2
 4
 6
 8
```

And now a 2-by-2 matrix:

# str2num

---

```
str2num('2 4; 6 8')
ans =
 2 4
 6 8
```

## See Also

[num2str](#) | [str2double](#) | [hex2num](#) | [sscanf](#) | [sparse](#) | [char](#) | [cast](#)  
| [special characters](#)

- Purpose** Concatenate strings horizontally
- Syntax** `combinedStr = strcat(s1,s2,...,sN)`
- Description** `combinedStr = strcat(s1,s2,...,sN)` horizontally concatenates strings in arrays. Inputs can be combinations of single strings, strings in scalar cells, character arrays with the same number of rows, and same-sized cell arrays of strings.
- If any input is a cell array, `combinedStr` is a cell array of strings. Otherwise, `combinedStr` is a character array.
  - For character array inputs, `strcat` removes trailing ASCII white-space characters: space, tab, vertical tab, newline, carriage return, and form-feed. For cell array inputs, `strcat` does not remove trailing white space.

## Examples

### Concatenate Two Strings

```
str = strcat('Good', 'morning')
```

```
str =
```

```
Goodmorning
```

### Concatenate Two Cell Arrays

```
a = {'abcde', 'fghi'};
```

```
b = {'jkl', 'mn'};
```

```
ab = strcat(a, b)
```

```
ab =
```

```
 'abcdejkl' 'fghimn'
```

## Concatenate Two Cell Arrays with Scalar Cell

```
a = {'abcde', 'fghi'};
b = {'jkl', 'mn'};
c = {'Q'};

abc = strcat(a, b, c)

abc =

 'abcdejklQ' 'fghimnQ'
```

## Input Arguments

### **s1,s2,...,sN** - Strings to horizontally concatenate

string | cell array of strings | character arrays

Strings to horizontally concatenate, specified as strings, cell arrays of strings, or character arrays with the same number of strings. When combining nonscalar cell arrays and multirow character arrays, cell arrays must be column vectors with the same number of rows as the character arrays.

### Data Types

char | cell

## Tips

- `strcat` strips trailing blank spaces. Adding a blank space at the end of the first string does not result in a blank space between the strings once concatenated.

```
str1 = strcat('Good ', 'morning')
```

```
str1 =
```

```
Goodmorning
```

Instead, add a blank space before the second string.

```
str2 = strcat('Good', ' morning')
```

```
str2 =
```



```
Good morning
```

- Strings can be horizontally concatenated using horizontal array concatenation. Horizontal array concatenation does not strip off trailing blank spaces from a string.

```
a = 'Good ';
b = 'Morning';

using_strcat = strcat(a, b)
using_arraycat = [a b] % Equivalent to horzcat(a, b)

using_strcat =

GoodMorning

using_arraycat =

Good Morning
```

**See Also**

cat | vertcat | horzcat | cellstr | strjoin | special character

# strcmp

---

**Purpose** Compare strings with case sensitivity

**Syntax** TF = strcmp(s1,s2)

**Description** TF = strcmp(s1,s2) compares two strings for equality. The strings are considered to be equal if the size and content of each are the same. The function returns a scalar logical 1 for equality, or a scalar logical 0 for inequality. The comparison is case sensitive.

Inputs can be two strings, two same-sized cell arrays of strings, or a combination of a string and a cell array.

- If s1 , s2 are strings, TF is a logical scalar.
- If at least one input is a cell array of strings, TF is a logical array the same size as the cell array.

**Input Arguments** **s1,s2 - Strings or cell array of strings to compare**  
string | cell array of strings

Strings or cell array of strings to compare for equality, specified as two strings or a string and a cell array of strings or two equal-sized cell arrays of strings. The order of the inputs does not effect the comparison results.

**Data Types**  
char | cell

**Examples** **Compare Two Strings**

Use strcmp to compare two different strings.

```
strcmp('Yes' , 'No')
```

```
ans =
```

```
0
```

`strcmp` returns logical 0 (false) because the two strings are not equal. Use `strcmp` to compare two equal strings.

```
strcmp('Yes' , 'Yes')
```

```
ans =
```

```
1
```

The function `strcmp` returns logical 1 (true) because the two strings are equal.

### **Compare String and Cell Array of Strings**

Use `strcmp` to compare a string, 'upon', to each element of a cell array of strings.

```
a = 'upon';
b = {'Once' 'upon';
 'a' 'time'};
strcmp(a, b)
```

```
ans =
```

```
0 1
0 0
```

There is only one occurrence of string a in array b, and that occurs at element b{1, 2}.

### **Compare Two Cell Arrays of Strings**

Use `strcmp` to compare each element in a cell array of strings to the corresponding element in a second cell array of strings.

```
c = {'Time' 'flies' 'when';
 'you're' 'having' 'fun.'};
d = {'Time' 'drags' 'when';
 'you're' 'anxiously' 'waiting.'};
```

# strcmp

---

```
strcmp(c, d)
```

```
ans =
```

```
 1 0 1
 1 0 0
```

There are three instances of equal strings between `c` and `d`. These are 'Time' at indices {1, 1}, 'when' at indices {1, 3}, and 'you're' at indices {2, 1}.

## Tips

- The `strcmp` function is intended for comparison of character data. When you use it to compare numeric data, `strcmp` returns logical 0.
- For case insensitive string comparison, use `strcmpi` instead of `strcmp`.
- Any leading or trailing blanks are explicitly included in the comparison.
- The value returned by `strcmp` is not the same as the C language convention.
- `strcmp` supports international character sets.

## See Also

`regexp` | `regexpi` | `strcmpi` | `strfind` | `strncmp` | `strncmpi`

<b>Purpose</b>	Compare strings (case insensitive)
<b>Syntax</b>	TF = strcmpi(string,string) TF = strcmpi(string,cellstr) TF = strcmpi(cellstr,cellstr)
<b>Description</b>	<p>TF = strcmpi(string,string) compares two strings for equality, ignoring any differences in letter case. The strings are considered to be equal if the size and content of each are the same. The function returns a scalar logical 1 for equality, or scalar logical 0 for inequality.</p> <p>TF = strcmpi(string,cellstr) compares a string with each element of a cell array of strings, ignoring letter case. The function returns a logical array the same size as the cellstr input in which logical 1 represents equality. The order of the input arguments is not important.</p> <p>TF = strcmpi(cellstr,cellstr) compares each element of one cell array of strings with the same element of the other, ignoring letter case. The function returns a logical array the same size as the input arrays.</p>
<b>Tips</b>	<ul style="list-style-type: none"><li>• The strcmpi function is intended for comparison of character data. When used to compare numeric data, it returns logical 0.</li><li>• Use strcmp for case-sensitive string comparisons.</li><li>• Any leading and trailing blanks in either of the strings are explicitly included in the comparison.</li><li>• The value returned by strcmpi is not the same as the C language convention.</li><li>• strcmpi supports international character sets.</li></ul>
<b>Input Arguments</b>	<p><b>string</b> A single character string or n-by-1 array of strings.</p> <p><b>cellstr</b> A cell array of strings.</p>

# strcmpi

---

## Output Arguments

### TF

When both inputs are character arrays, TF is a scalar logical value. This value is logical 1 (true) if the size and content of both arrays are equal, and logical 0 (false) if they are not.

When either or both inputs are a cell array of strings, TF is an array of logical ones and zeros. This array is the same size as the input cell array(s), and contains logical 1 (true) for those elements of the input arrays that are a match, and logical 0 (false) for those elements that are not.

## Examples

Perform a simple case-insensitive comparison of two strings:

```
strcmpi('Yes', 'No')
ans =
 0
strcmpi('Yes', 'yes')
ans =
 1
```

---

Create two cell arrays of strings and call strcmpi to compare them:

```
A = {'Handle Graphics', 'Statistics'; ...
 'Toolboxes', 'MathWorks'};

B = {'Handle Graphics', 'Signal Processing'; ...
 'Toolboxes', 'MATHWORKS'};

match = strcmpi(A, B)
match =
 1 0
 0 1
```

The result of comparing the two cell arrays is:

- `match{1,1}` is 1 because “Handle Graphics” in `A{1,1}` matches the same text in `B{1,1}`.

- `match{1,2}` is 0 because “Statistics” in `A{1,2}` does not match “Signal Processing” in `B{1,2}`.
- `match{2,1}` is 0 because “ Toolboxes”, in `A{2,1}` contains leading space characters that are not in `B{2,1}`.
- `match{2,2}` is 1 because even though “MathWorks” in `A{2,2}` uses different letter case than “MATHWORKS” in `B{2,2}`, `strcmpi` performs the comparison without sensitivity to letter case.

## See Also

`strncmpi` | `strcmp` | `strncmp` | `strfind` | `regexpi` | `regexp`

# stream2

---

**Purpose** Compute 2-D streamline data

**Syntax**

```
XY = stream2(x,y,u,v,startx,starty)
XY = stream2(u,v,startx,starty)
XY = stream2(...,options)
```

**Description** `XY = stream2(x,y,u,v,startx,starty)` computes streamlines from vector data `u` and `v`.

The arrays `x` and `y`, which define the coordinates for `u` and `v`, must be monotonic, but do not need to be uniformly spaced. `x` and `y` must have the same number of elements, as if produced by `meshgrid`.

`startx` and `starty` define the starting positions of the streamlines. The section "Specifying Starting Points for Stream Plots" provides more information on defining starting points.

The returned value `XY` contains a cell array of vertex arrays.

`XY = stream2(u,v,startx,starty)` assumes the arrays `x` and `y` are defined as `[x,y] = meshgrid(1:n,1:m)` where `[m,n] = size(u)`.

`XY = stream2(...,options)` specifies the options used when creating the streamlines. Define `options` as a one- or two-element vector containing the step size or the step size and the maximum number of vertices in a streamline:

```
[stepsize]
```

or

```
[stepsize, max_number_vertices]
```

If you do not specify a value, MATLAB software uses the default:

- Step size = 0.1 (one tenth of a cell)
- Maximum number of vertices = 10000

Use the `streamline` command to plot the data returned by `stream2`.



**Examples**

This example draws 2-D streamlines from data representing air currents over regions of North America.

```
load wind
[sx,sy] = meshgrid(80,20:10:50);
streamline(stream2(x(:,:,5),y(:,:,5),u(:,:,5),v(:,:,5),sx,sy));
```

**See Also**

[coneplot](#) | [stream3](#) | [streamline](#)

**How To**

- [Specifying Starting Points for Stream Plots](#)

# stream3

---

**Purpose** Compute 3-D streamline data

**Syntax**

```
XYZ = stream3(X,Y,Z,U,V,W,startx,starty,startz)
XYZ = stream3(U,V,W,startx,starty,startz)
XYZ = stream3(...,options)
```

**Description** `XYZ = stream3(X,Y,Z,U,V,W,startx,starty,startz)` computes streamlines from vector data `U, V, W`.

The arrays `X, Y, and Z`, which define the coordinates for `U, V, and W`, must be monotonic, but do not need to be uniformly spaced. `X, Y, and Z` must have the same number of elements, as if produced by `meshgrid`.

`startx, starty, and startz` define the starting positions of the streamlines. The section "Specifying Starting Points for Stream Plots" provides more information on defining starting points.

The returned value `XYZ` contains a cell array of vertex arrays.

`XYZ = stream3(U,V,W,startx,starty,startz)` assumes the arrays `X, Y, and Z` are defined as `[X,Y,Z] = meshgrid(1:N,1:M,1:P)` where `[M,N,P] = size(U)`.

`XYZ = stream3(...,options)` specifies the options used when creating the streamlines. Define `options` as a one- or two-element vector containing the step size or the step size and the maximum number of vertices in a streamline:

```
[stepsize]
```

or

```
[stepsize, max_number_vertices]
```

If you do not specify values, MATLAB software uses the default:

- Step size = 0.1 (one tenth of a cell)
- Maximum number of vertices = 10000

Use the `streamline` command to plot the data returned by `stream3`.

**Examples**

This example draws 3-D streamlines from data representing air currents over regions of North America.

```
load wind
[sx sy sz] = meshgrid(80,20:10:50,0:5:15);
streamline(stream3(x,y,z,u,v,w,sx,sy,sz))
view(3)
```

**See Also**

[coneplot](#) | [stream2](#) | [streamline](#)

**How To**

- [Specifying Starting Points for Stream Plots](#)

# streamline

---

## Purpose

Plot streamlines from 2-D or 3-D vector data



## Syntax

```
streamline(X,Y,Z,U,V,W,startx,starty,startz)
streamline(U,V,W,startx,starty,startz)
streamline(XYZ)
streamline(X,Y,U,V,startx,starty)
streamline(U,V,startx,starty)
streamline(XY)
streamline(...,options)
streamline(axes_handle,...)
h = streamline(...)
```

## Description

`streamline(X,Y,Z,U,V,W,startx,starty,startz)` draws streamlines from 3-D vector data  $U$ ,  $V$ ,  $W$ .

The arrays  $X$ ,  $Y$ , and  $Z$ , which define the coordinates for  $U$ ,  $V$ , and  $W$ , must be monotonic, but do not need to be uniformly spaced.  $X$ ,  $Y$ , and  $Z$  must have the same number of elements, as if produced by `meshgrid`.

`startx`, `starty`, `startz` define the starting positions of the streamlines. The section [Specifying Starting Points for Stream Plots](#) provides more information on defining starting points.

`streamline(U,V,W,startx,starty,startz)` assumes the arrays  $X$ ,  $Y$ , and  $Z$  are defined as  $[X,Y,Z] = \text{meshgrid}(1:N,1:M,1:P)$ , where  $[M,N,P] = \text{size}(U)$ .

`streamline(XYZ)` assumes  $XYZ$  is a precomputed cell array of vertex arrays (as produced by `stream3`).

`streamline(X,Y,U,V,startx,starty)` draws streamlines from 2-D vector data  $U$ ,  $V$ .

The arrays  $X$  and  $Y$ , which define the coordinates for  $U$  and  $V$ , must be monotonic, but do not need to be uniformly spaced.  $X$  and  $Y$  must have the same number of elements, as if produced by `meshgrid`.

`startx` and `starty` define the starting positions of the streamlines. The output argument `h` contains a vector of line handles, one handle for each streamline.

`streamline(U,V,startx,starty)` assumes the arrays `X` and `Y` are defined as `[X,Y] = meshgrid(1:N,1:M)`, where `[M,N] = size(U)`.

`streamline(XY)` assumes `XY` is a precomputed cell array of vertex arrays (as produced by `stream2`).

`streamline(...,options)` specifies the options used when creating the streamlines. Define `options` as a one- or two-element vector containing the step size or the step size and the maximum number of vertices in a streamline:

```
[stepsize]
```

or

```
[stepsize, max_number_vertices]
```

If you do not specify values, MATLAB uses the default:

- Step size = 0.1 (one tenth of a cell)
- Maximum number of vertices = 1000

`streamline(axes_handle,...)` plots into the axes object with the handle `axes_handle` instead of the into current axes object (`gca`).

`h = streamline(...)` returns a vector of line handles, one handle for each streamline.

## Examples

### Draw Streamlines

Define arrays `x`, `y`, `u`, and `v`.

```
[x,y] = meshgrid(0:0.1:1,0:0.1:1);
u = x;
v = -y;
```

# streamline

Create a quiver plot of the data. Plot streamlines that start at different points along the line  $y = 1$ .

```
figure
quiver(x,y,u,v)

startx = 0.1:0.1:1;
starty = ones(size(startx));
streamline(x,y,u,v,startx,starty);
```

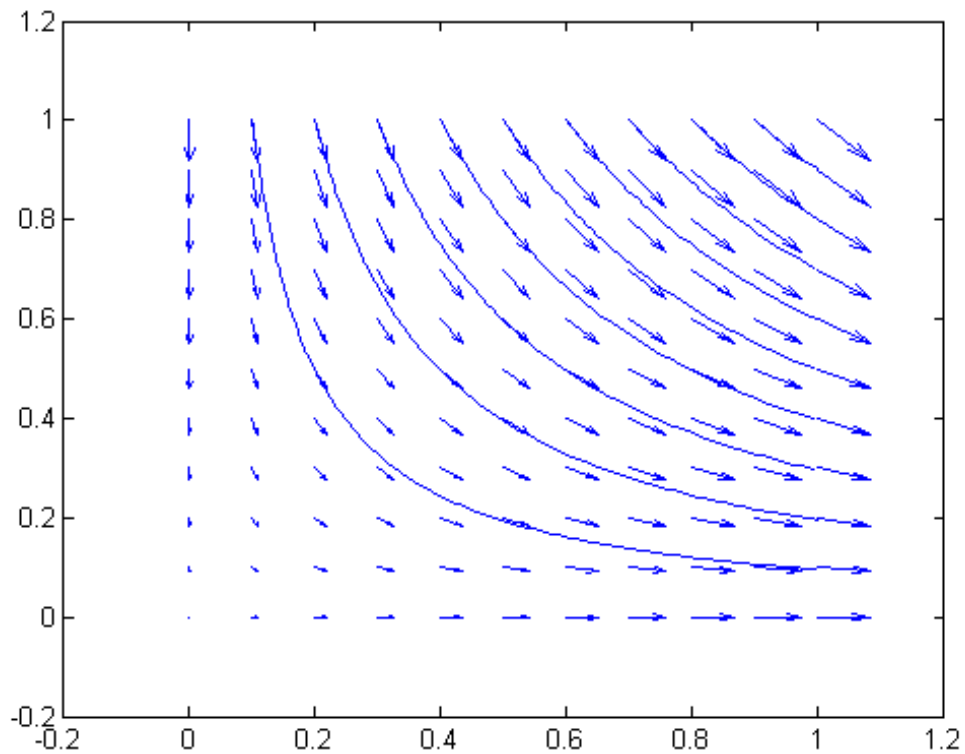

**See Also**

`coneplot` | `stream2` | `stream3` | `streamparticles` | `meshgrid`

**How To**

- [Specifying Starting Points for Stream Plots](#)
- [Stream Line Plots of Vector Data](#)

# streamparticles

---

**Purpose** Plot stream particles

**Syntax**

```
streamparticles(vertices)
streamparticles(vertices,n)
streamparticles(...,'PropertyName',PropertyValue,...)
streamparticles(line_handle,...)
h = streamparticles(...)
```

**Description** `streamparticles(vertices)` draws stream particles of a vector field. Stream particles are usually represented by markers and can show the position and velocity of a streamline. `vertices` is a cell array of 2-D or 3-D vertices (as if produced by `stream2` or `stream3`).

`streamparticles(vertices,n)` uses `n` to determine how many stream particles to draw. The `ParticleAlignment` property controls how `n` is interpreted.

- If `ParticleAlignment` is set to `off` (the default) and `n` is greater than 1, approximately `n` particles are drawn evenly spaced over the streamline vertices.

If `n` is less than or equal to 1, `n` is interpreted as a fraction of the original stream vertices; for example, if `n` is 0.2, approximately 20% of the vertices are used.

`n` determines the upper bound for the number of particles drawn. The actual number of particles can deviate from `n` by as much as a factor of 2.

- If `ParticleAlignment` is `on`, `n` determines the number of particles on the streamline having the most vertices and sets the spacing on the other streamlines to this value. The default value is `n = 1`.

`streamparticles(...,'PropertyName',PropertyValue,...)` controls the stream particles using named properties and specified values. Any unspecified properties have default values. MATLAB ignores the case of property names.

## Stream Particle Properties

`Animate` — Stream particle motion [nonnegative integer]



The number of times to animate the stream particles. The default is 0, which does not animate. `Inf` animates until you enter **Ctrl+C**.

**FrameRate** — Animation frames per second [nonnegative integer]

This property specifies the number of frames per second for the animation. `Inf`, the default, draws the animation as fast as possible. Note that the speed of the animation might be limited by the speed of the computer. In such cases, the value of **FrameRate** cannot necessarily be achieved.

**ParticleAlignment** — Align particles with streamlines [on | {off}]

Set this property to `on` to draw particles at the beginning of each streamline. This property controls how `streamparticles` interprets the argument `n` (number of stream particles).

Stream particles are line objects. In addition to stream particle properties, you can specify any line object property, such as **Marker** and **EraseMode**. `streamparticles` sets the following line properties when called.

Line Property	Value Set by <code>streamparticles</code>
<code>EraseMode</code>	<code>xor</code>
<code>LineStyle</code>	<code>none</code>
<code>Marker</code>	<code>o</code>
<code>MarkerEdgeColor</code>	<code>none</code>
<code>MarkerFaceColor</code>	<code>red</code>

You can override any of these properties by specifying a property name and value as arguments to `streamparticles`. For example, this statement uses RGB values to set the `MarkerFaceColor` to medium gray:

```
streamparticles(vertices, 'MarkerFaceColor', [.5 .5 .5])
```

# streamparticles

---

`streamparticles(line_handle,...)` uses the line object identified by `line_handle` to draw the stream particles.

`h = streamparticles(...)` returns a vector of handles to the line objects it creates.

## Examples

This example combines streamlines with stream particle animation. The `interpstreamspeed` function determines the vertices along the streamlines where stream particles are drawn during the animation, thereby controlling the speed of the animation. Setting the figure `Renderer` property to `opengl` provides faster rendering.

```
load wind
figure('Renderer','opengl')
[sx,sy,sz] = meshgrid(80,20:1:55,5);
verts = stream3(x,y,z,u,v,w,sx,sy,sz);
sl = streamline(verts);
iverts = interpstreamspeed(x,y,z,u,v,w,verts,.025);
axis tight manual; view(30,30); daspect([1 1 .125])
camproj perspective; camva(8)
box on
streamparticles(iverts,35,'animate',10,'ParticleAlignment','on')
```

The following picture is a static view of the animation.

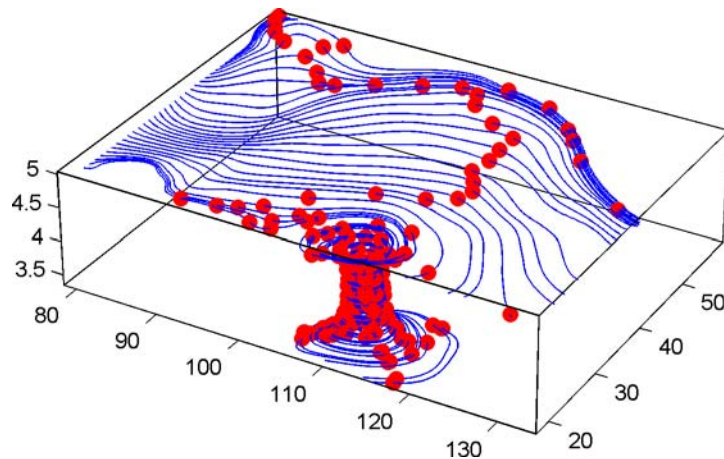

This example uses the streamlines in the  $z = 5$  plane to animate the flow along these lines with streamparticles.

```
load wind
daspect([1,1,1]); view(2)
[verts,averts] = streamslice(x,y,z,u,v,w,[],[],[5]);
sl = streamline([verts averts]);
axis tight manual off;
set(sl,'Visible','off')
iverts = interpstreamspeed(x,y,z,u,v,w,verts,.05);
set(gca,'Position',[0 0 1 1],'ZLim',[4.9 5.1])
set(gcf,'Color','black')
streamparticles(iverts, 200, ...
 'Animate',100,'FrameRate',40, ...
 'MarkerSize',10,'MarkerFaceColor','yellow')
```

## See Also

[interpstreamspeed](#) | [stream3](#) | [streamline](#) | [stream2](#)

## How To

- [Creating Stream Particle Animations](#)
- [Specifying Starting Points for Stream Plots](#)

# streamribbon

---

**Purpose** 3-D stream ribbon plot from vector volume data



**Syntax**

```
streamribbon(X,Y,Z,U,V,W,startx,starty,startz)
streamribbon(U,V,W,startx,starty,startz)
streamribbon(vertices,X,Y,Z,cav,speed)
streamribbon(vertices,cav,speed)
streamribbon(vertices,twistangle)
streamribbon(...,width)
streamribbon(axes_handle,...)
h = streamribbon(...)
```

**Description** `streamribbon(X,Y,Z,U,V,W,startx,starty,startz)` draws stream ribbons from vector volume data `U`, `V`, `W`.

The arrays `X`, `Y`, and `Z`, which define the coordinates for `U`, `V`, and `W`, must be monotonic, but do not need to be uniformly spaced. `X`, `Y`, and `Z` must have the same number of elements, as if produced by `meshgrid`.

`startx`, `starty`, and `startz` define the starting positions of the stream ribbons at the center of the ribbons. The section [Specifying Starting Points for Stream Plots](#) provides more information on defining starting points.

The twist of the ribbons is proportional to the curl of the vector field. The width of the ribbons is calculated automatically.

`streamribbon(U,V,W,startx,starty,startz)` assumes `X`, `Y`, and `Z` are determined by the expression

```
[X,Y,Z] = meshgrid(1:n,1:m,1:p)
```

where `[m,n,p] = size(U)`.

`streamribbon(vertices,X,Y,Z,cav,speed)` assumes precomputed streamline vertices, curl angular velocity, and flow speed. `vertices` is a

cell array of streamline vertices (as produced by `stream3`). `X`, `Y`, `Z`, `cav`, and `speed` are 3-D arrays.

`streamribbon(vertices,cav,speed)` assumes `X`, `Y`, and `Z` are determined by the expression

```
[X,Y,Z] = meshgrid(1:n,1:m,1:p)
```

where `[m,n,p] = size(cav)`.

`streamribbon(vertices,twistangle)` uses the cell array of vectors `twistangle` for the twist of the ribbons (in radians). The size of each corresponding element of `vertices` and `twistangle` must be equal.

`streamribbon(...,width)` sets the width of the ribbons to `width`.

`streamribbon(axes_handle,...)` plots into the axes object with the handle `axes_handle` instead of into the current axes object (`gca`).

`h = streamribbon(...)` returns a vector of handles (one per start point) to surface objects.

## Examples

This example uses stream ribbons to indicate the flow in the wind data set. Inputs include the coordinates, vector field components, and starting location for the stream ribbons.

```
figure
load wind
[sx sy sz] = meshgrid(80,20:10:50,0:5:15);
streamribbon(x,y,z,u,v,w,sx,sy,sz);
% Define viewing and lighting
axis tight
shading interp;
view(3);
camlight; lighting gouraud
```

# streamribbon

---

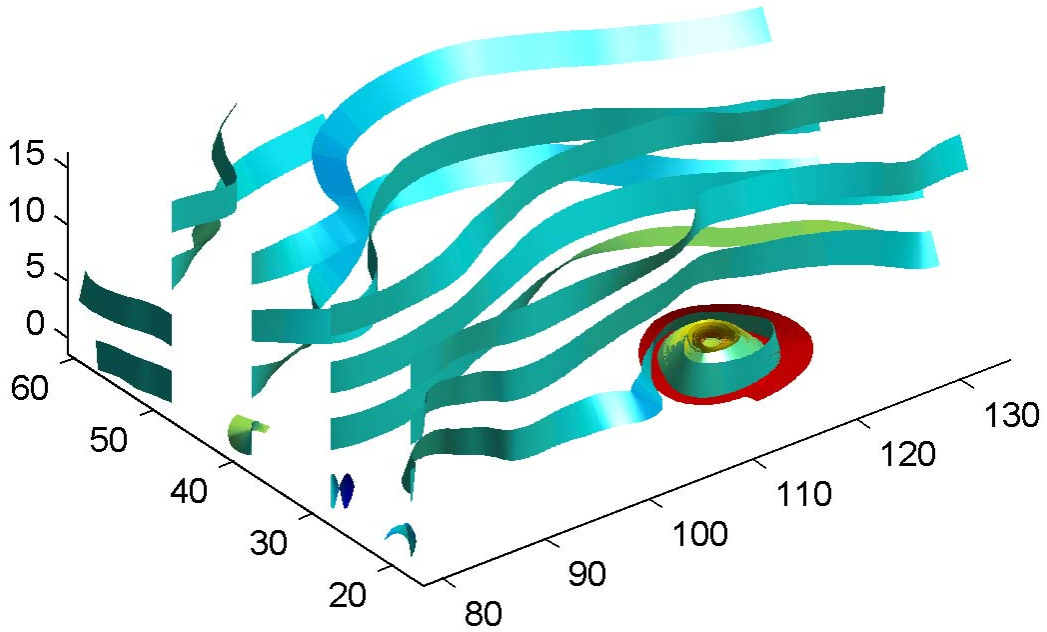

This example uses precalculated vertex data (`stream3`), curl average velocity (`curl1`), and speed  $\sqrt{u^2 + v^2 + w^2}$ . Using precalculated data enables you to use values other than those calculated from the single data source. In this case, the speed is reduced by a factor of 10 compared to the previous example.

figure

```
load wind
[sx sy sz] = meshgrid(80,20:10:50,0:5:15);
verts = stream3(x,y,z,u,v,w,sx,sy,sz);
cav = curl(x,y,z,u,v,w);
spd = sqrt(u.^2 + v.^2 + w.^2).*0.1;
streamribbon(verts,x,y,z,cav,spd);
% Define viewing and lighting
axis tight
shading interp
view(3)
camlight; lighting gouraud
```

# streamribbon

---

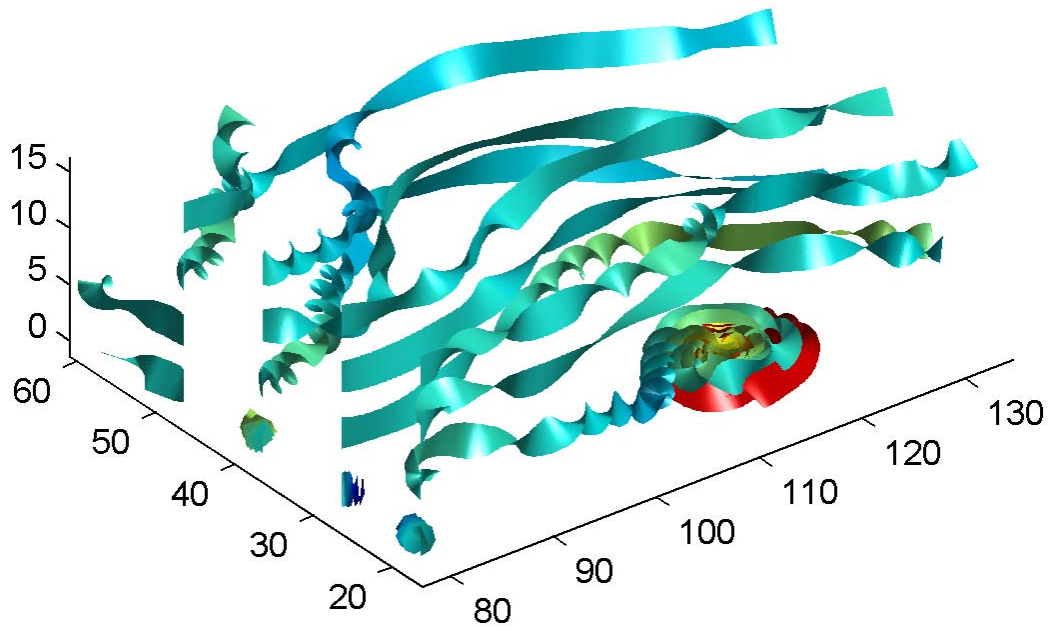

This example specifies a twist angle for the stream ribbon.

```
figure
t = 0:.15:15;
verts = {[cos(t)' sin(t)' (t/3)']};
twistangle = {cos(t)'};
streamribbon(verts,twistangle);
% Define viewing and lighting
```



```
axis tight
shading interp;
view(3);
camlight; lighting gouraud
```

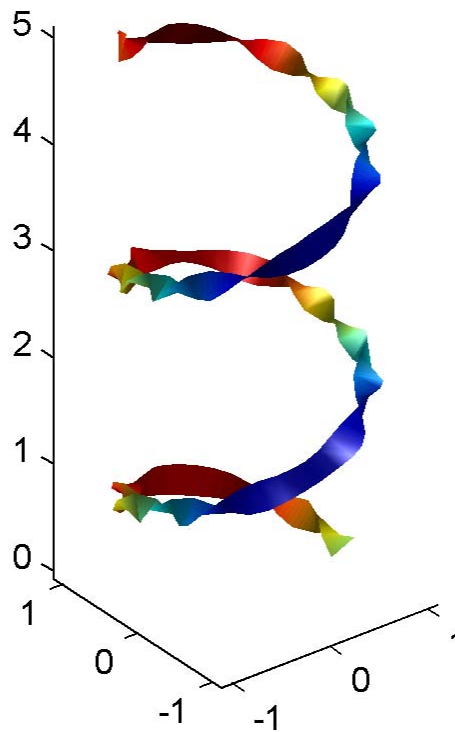

This example combines cone plots (coneplot) and stream ribbon plots in one graph.

# streamribbon

---

```
figure
% Define 3-D arrays x, y, z, u, v, w
xmin = -7; xmax = 7;
ymin = -7; ymax = 7;
zmin = -7; zmax = 7;
x = linspace(xmin,xmax,30);
y = linspace(ymin,ymax,20);
z = linspace(zmin,zmax,20);
[x y z] = meshgrid(x,y,z);
u = y; v = -x; w = 0*x+1;
[cx cy cz] = meshgrid(linspace(xmin,xmax,30),...
 linspace(ymin,ymax,30),[-3 4]);
h = coneplot(x,y,z,u,v,w,cx,cy,cz,'quiver');
set(h,'Color','k');

% Plot two sets of streamribbons
[sx sy sz] = meshgrid([-1 0 1],[-1 0 1],-6);
streamribbon(x,y,z,u,v,w,sx,sy,sz);
[sx sy sz] = meshgrid([1:6],[0],-6);
streamribbon(x,y,z,u,v,w,sx,sy,sz);

% Define viewing and lighting
shading interp
view(-30,10) ; axis off tight
camproj perspective; camva(66); camlookat;
camdolly(0,0,.5,'fixtarget')
camlight
```

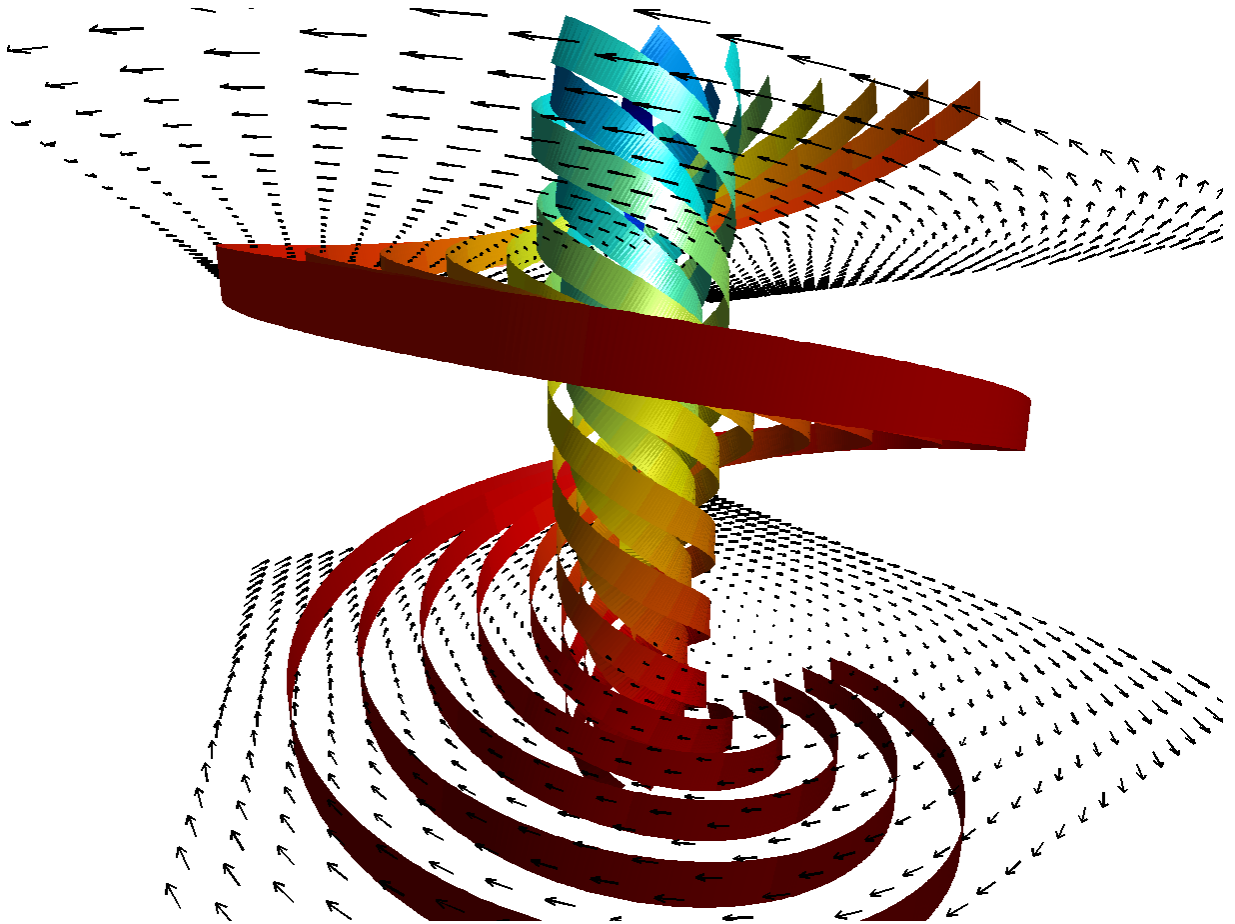

## See Also

[curl](#) | [streamtube](#) | [streamline](#) | [stream3](#) | [meshgrid](#) | [coneplot](#)

## How To

- “Volume Visualization”
- Displaying Curl with Stream Ribbons
- Specifying Starting Points for Stream Plots

# streamslice

---

## Purpose

Plot streamlines in slice planes

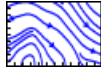

## Syntax

```
streamslice(X,Y,Z,U,V,W,startx,starty,startz)
streamslice(U,V,W,startx,starty,startz)
streamslice(X,Y,U,V)
streamslice(U,V)
streamslice(...,density)
streamslice(...,'arrowmode')
streamslice(...,'method')
streamslice(axes_handle,...)
h = streamslice(...)
[vertices arrowvertices] = streamslice(...)
```

## Description

`streamslice(X,Y,Z,U,V,W,startx,starty,startz)` draws well-spaced streamlines (with direction arrows) from vector data `U`, `V`, `W` in axis aligned  $x$ -,  $y$ -,  $z$ -planes at the points in the vectors `startx`, `starty`, `startz`. The section [Specifying Starting Points for Stream Plots](#) provides more information on defining starting points.

The arrays `X`, `Y`, and `Z`, which define the coordinates for `U`, `V`, and `W`, must be monotonic, but do not need to be uniformly spaced. `X`, `Y`, and `Z` must have the same number of elements, as if produced by `meshgrid`. `U`, `V`, `W` must be  $m$ -by- $n$ -by- $p$  volume arrays.

Do not assume that the flow is parallel to the slice plane. For example, in a stream slice at a constant  $z$ , the  $z$  component of the vector field `W` is ignored when you are calculating the streamlines for that plane.

Stream slices are useful for determining where to start streamlines, stream tubes, and stream ribbons.

`streamslice(U,V,W,startx,starty,startz)` assumes `X`, `Y`, and `Z` are determined by the expression

```
[X,Y,Z] = meshgrid(1:n,1:m,1:p)
```

where `[m,n,p] = size(U)`.

`streamslice(X,Y,U,V)` draws well-spaced streamlines (with direction arrows) from vector volume data `U, V`.

The arrays `X` and `Y`, which define the coordinates for `U` and `V`, must be monotonic, but do not need to be uniformly spaced. `X` and `Y` must have the same number of elements, as if produced by `meshgrid`.

`streamslice(U,V)` assumes `X, Y`, and `Z` are determined by the expression

```
[X,Y,Z] = meshgrid(1:n,1:m,1:p)
```

where `[m,n,p] = size(U)`.

`streamslice(...,density)` modifies the automatic spacing of the streamlines. `density` must be greater than 0. The default value is 1; higher values produce more streamlines on each plane. For example, 2 produces approximately twice as many streamlines, while 0.5 produces approximately half as many.

`streamslice(...,'arrowmode')` determines if direction arrows are present or not. `arrowmode` can be

- `arrows` — Draw direction arrows on the streamlines (default).
- `noarrows` — Do not draw direction arrows.

`streamslice(...,'method')` specifies the interpolation method to use. `method` can be

- `linear` — Linear interpolation (default)
- `cubic` — Cubic interpolation
- `nearest` — Nearest-neighbor interpolation

See `interp3` for more information on interpolation methods.

`streamslice(axes_handle,...)` plots into the axes object with the handle `axes_handle` instead of into the current axes object (`gca`).

# streamslice

---

`h = streamslice(...)` returns a vector of handles to the line objects created.

`[vertices arrowvertices] = streamslice(...)` returns two cell arrays of vertices for drawing the streamlines and the arrows. You can pass these values to any of the streamline drawing functions (`streamline`, `streamribbon`, `streamtube`).

## Examples

### Plot Streamlines in Slice Plane

Load the wind data set. Draw a stream slice at  $z = 5$ .

```
load wind
```

```
figure
streamslice(x,y,z,u,v,w,[],[],[5])
axis tight
```

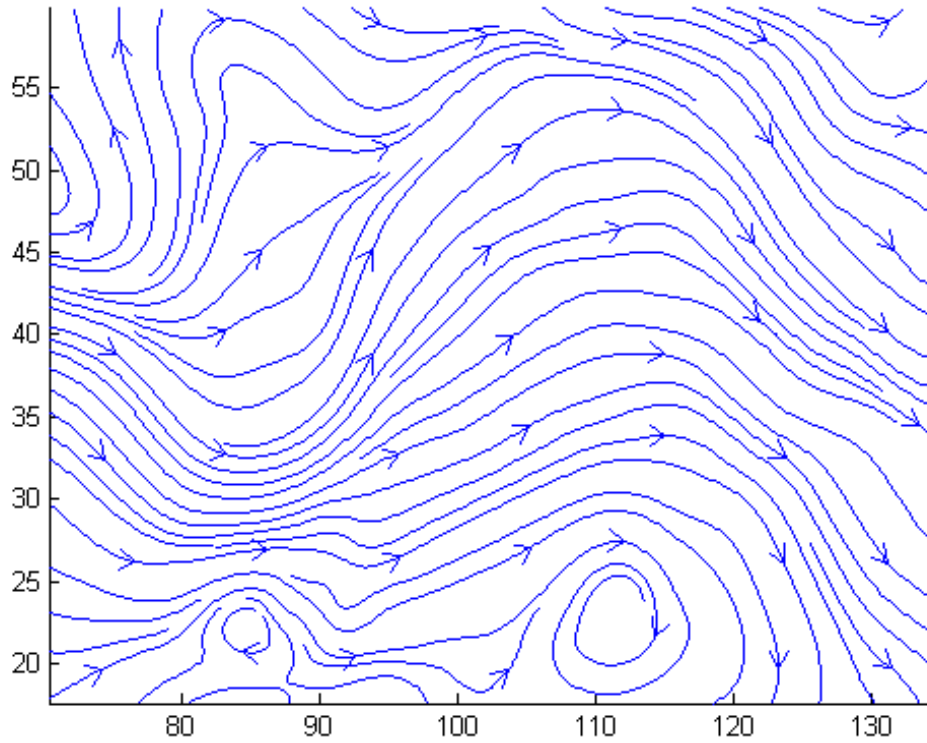

## See Also

[contourslice](#) | [slice](#) | [streamline](#) | [volumebounds](#) | [meshgrid](#) | [interp3](#) | [interp2](#) | [streamribbon](#) | [streamtube](#)

## How To

- [Specifying Starting Points for Stream Plots](#)

# streamtube

---

**Purpose** Create 3-D stream tube plot



**Syntax**

```
streamtube(X,Y,Z,U,V,W,startx,starty,startz)
streamtube(U,V,W,startx,starty,startz)
streamtube(vertices,X,Y,Z,divergence)
streamtube(vertices,divergence)
streamtube(vertices,width)
streamtube(vertices)
streamtube(...,[scale n])
streamtube(axes_handle,...)
h = streamtube(...z)
```

**Description** `streamtube(X,Y,Z,U,V,W,startx,starty,startz)` draws stream tubes from vector volume data `U, V, W`.

The arrays `X, Y, and Z`, which define the coordinates for `U, V, and W`, must be monotonic, but do not need to be uniformly spaced. `X, Y, and Z` must have the same number of elements, as if produced by `meshgrid`.

`startx, starty, and startz` define the starting positions of the streamlines at the center of the tubes. The section [Specifying Starting Points for Stream Plots](#) provides more information on defining starting points.

The width of the tubes is proportional to the normalized divergence of the vector field.

`streamtube(U,V,W,startx,starty,startz)` assumes `X, Y, and Z` are determined by the expression

```
[X,Y,Z] = meshgrid(1:n,1:m,1:p)
```

where `[m,n,p] = size(U)`.

`streamtube(vertices,X,Y,Z,divergence)` assumes precomputed streamline vertices and divergence. `vertices` is a cell array of



streamline vertices (as produced by `stream3`). `X`, `Y`, `Z`, and divergence are 3-D arrays.

`streamtube(vertices,divergence)` assumes `X`, `Y`, and `Z` are determined by the expression

```
[X,Y,Z] = meshgrid(1:n,1:m,1:p)
```

where `[m,n,p] = size(divergence)`.

`streamtube(vertices,width)` specifies the width of the tubes in the cell array of vectors, `width`. The size of each corresponding element of `vertices` and `width` must be equal. `width` can also be a scalar, specifying a single value for the width of all stream tubes.

`streamtube(vertices)` selects the width automatically.

`streamtube(...,[scale n])` scales the width of the tubes by `scale`. The default is `scale = 1`. When the stream tubes are created, using start points or divergence, specifying `scale = 0` suppresses automatic scaling. `n` is the number of points along the circumference of the tube. The default is `n = 20`.

`streamtube(axes_handle,...)` plots into the axes object with the handle `axes_handle` instead of into the current axes object (`gca`).

`h = streamtube(...z)` returns a vector of handles (one per start point) to surface objects used to draw the stream tubes.

## Examples

This example uses stream tubes to indicate the flow in the wind data set. Inputs include the coordinates, vector field components, and starting location for the stream tubes.

```
figure
load wind
[sx sy sz] = meshgrid(80,20:10:50,0:5:15);
streamtube(x,y,z,u,v,w,sx,sy,sz);
% Define viewing and lighting
view(3)
axis tight
```

# streamtube

```
shading interp;
camlight; lighting gouraud
```

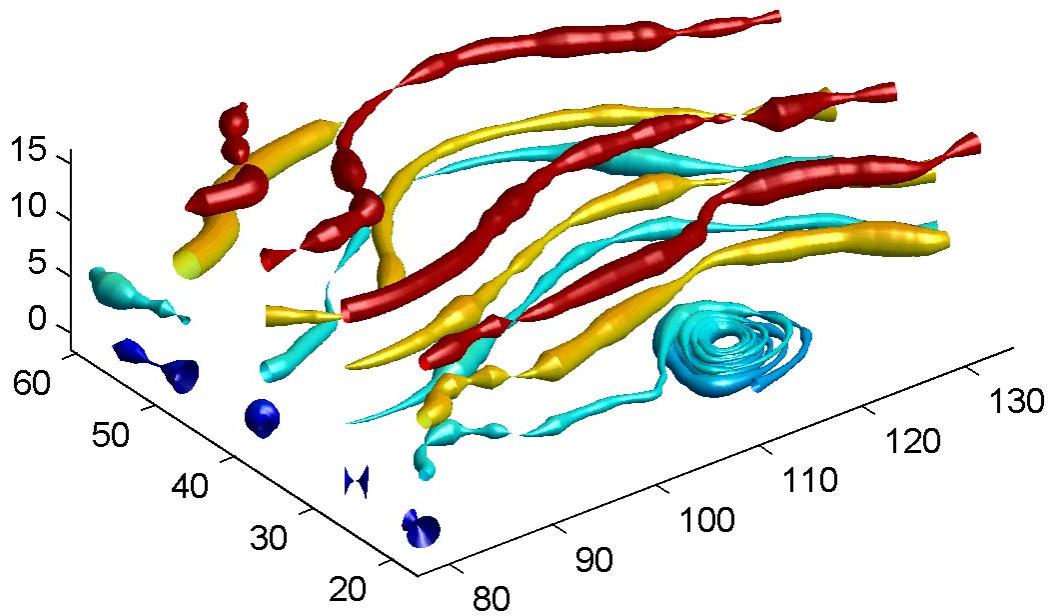

This example uses precalculated vertex data (`stream3`) and divergence (`divergence`).

```
figure
load wind
```

```
[sx sy sz] = meshgrid(80,20:10:50,0:5:15);
verts = stream3(x,y,z,u,v,w,sx,sy,sz);
div = divergence(x,y,z,u,v,w);
streamtube(verts,x,y,z,-div);
% Define viewing and lighting
view(3)
axis tight
shading interp
camlight; lighting gouraud
```

# streamtube

---

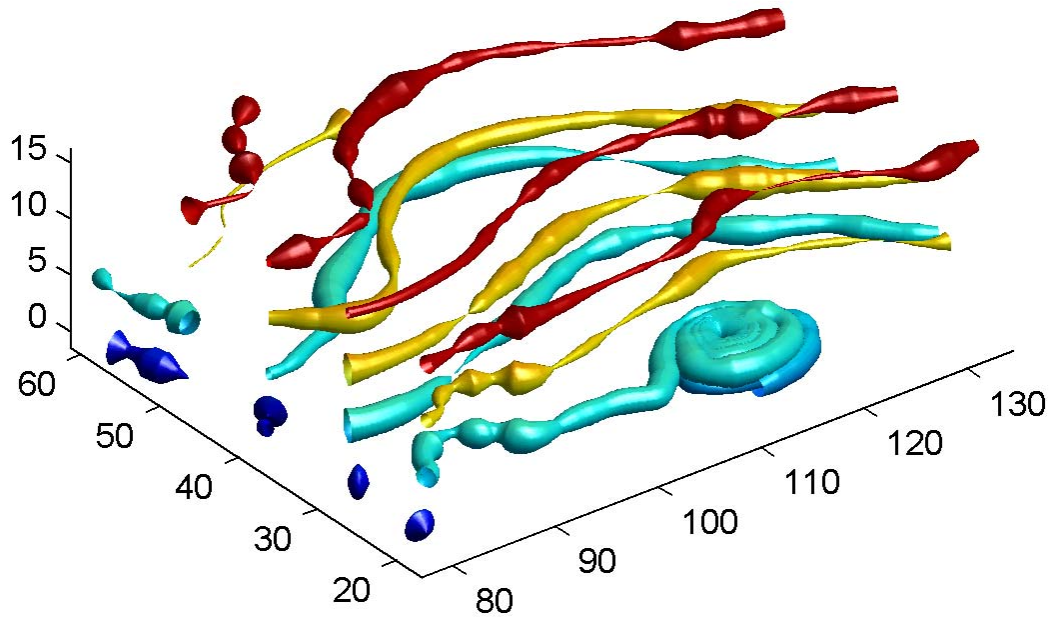

## See Also

[divergence](#) | [streamribbon](#) | [streamline](#) | [stream3](#) | [meshgrid](#) | [stream3](#)

## How To

- [Displaying Divergence with Stream Tubes](#)
- [Specifying Starting Points for Stream Plots](#)

**Purpose** Find one string within another

**Syntax** `k = strfind(str, pattern)`

**Description** `k = strfind(str, pattern)` searches `str` for occurrences of `pattern`. The output, `k`, indicates the starting index of each occurrence of `pattern` in `str`. If `pattern` is not found `strfind` returns an empty array, `[]`. The `strfind` function executes a case sensitive search.

- If `str` is a string, `strfind` returns a vector of type `double`.
- If `str` is a cell array, `strfind` returns a cell array of vectors of type `double`.

### **Input Arguments**

#### **str - Data to be searched**

string | cell array of strings

Data to be searched, specified as a string or cell array of strings.

#### **Data Types**

char | cell

#### **pattern - Search pattern**

string

Search pattern, specified as a string.

#### **Data Types**

char

### **Output Arguments**

#### **k - Indices of occurrences of pattern**

array

Indices of occurrences of `pattern`, returned as an array. If `pattern` is not found, then `k` is an empty array, `[]`.

- If `str` is a string, `k` is an array of doubles indicating the index of each occurrence of `pattern`.

# strfind

---

- If `str` is a cell array of strings, `k` is a cell array with each element being an array of type `double` corresponding to the indices of each occurrence of `pattern` in the corresponding element of `str`.

## Examples

### Find String Pattern

Define string `S` as follows:

```
S = 'Find the starting indices of the pattern string';
```

Find the pattern `in` in string `S`.

```
k = strfind(S, 'in')
```

```
k =
```

```
 2 15 19 45
```

There are four instances of the substring, `in`, found in `S`.

Find the pattern `In` in string `S`.

```
k = strfind(S, 'In')
```

```
k =
```

```
 []
```

Since `strfind` is case sensitive, the string, `In`, is not found in `S`, `k` is an empty array.

Find the blank spaces in string `S`.

```
k = strfind(S, ' ')
```

```
k =
```

```
 5 9 18 26 29 33 41
```

There are seven occurrences of blank spaces in the string S.

### Find String in Cell Array of Strings

Define the cell array of strings, `cstr`, as follows:

```
cstr = {'How much wood would a woodchuck chuck';
 'if a woodchuck could chuck wood?'};
```

Find the pattern, `wood`, in cell array `cstr`.

```
idx = strfind(cstr, 'wood')
```

```
idx =
```

```
 [1x2 double]
 [1x2 double]
```

Examine the output cell array to find the instances of `wood`.

```
idx{:,:}
```

```
ans =
```

```
 10 23
```

```
ans =
```

```
 6 28
```

The pattern, `wood`, occurs at indices 10 and 23 in the first string and at indices 6 and 28 in the second string.

### Tips

- The `strfind` function does not find a pattern of empty strings, `''`, within `str`.

# strfind

---

## See Also

strtok | strcmp | strncmp | strcmpi | strncmpi | regexp | regexpi  
| regexprep | strrep | strsplit



**Purpose**

String handling

**Syntax**

```
S = 'Any Characters'
S = [S1 S2 ...]
C = {S1 S2 ...}
S = strcat(S1, S2, ...)
S = char(S1, S2, ...)
S = char(X)
X = double(S)
```

**Description**

`S = 'Any Characters'` creates a character array, or string. The string is actually a vector that contains the numeric codes for the characters (codes 0 to 127 are ASCII). The length of `S` is the number of characters. A quotation within the string is indicated by two quotation marks.

`S = [S1 S2 ...]` concatenates character arrays `S1`, `S2`, etc. into a new character array, `S`.

`C = {S1 S2 ...}` creates a cell array of strings. Separate each row of the cell array with a semicolon (;).

`S = strcat(S1, S2, ...)` horizontally concatenates `S1`, `S2`, etc., which can be character arrays or cell arrays of strings. If the inputs are character arrays, `strcat` removes trailing white space. For more information, see the `strcat` reference page.

`S = char(S1, S2, ...)` vertically concatenates character arrays `S1`, `S2`, etc., padding each input string as needed so that each row contains the same number of characters.

`S = char(X)` converts an array that contains positive integers representing numeric codes into a MATLAB character array.

`X = double(S)` converts the string to its equivalent integer numeric codes.

**Tips**

- To convert between character arrays and cell arrays of strings, use `char` and `cellstr`. Most string functions support both types.

# strings

---

- To determine whether S is a character array or cell array, call `ischar(S)` or `iscellstr(S)`.

## Examples

Create a simple string that includes a single quote.

```
msg = 'You're right!'
```

```
msg =
You're right!
```

Create the string name using two methods of concatenation.

```
name = ['Thomas' ' R. ' 'Lee']
name = strcat('Thomas', ' R.', ' Lee')
```

Create a character array of strings.

```
C = char('Hello', 'Goodbye', 'Yes', 'No')
```

```
C =
Hello
Goodbye
Yes
No
```

Create a cell array of strings.

```
S = {'Hello' 'Goodbye'; 'Yes' 'No'}
```

```
S =
 'Hello' 'Goodbye'
 'Yes' 'No'
```

## See Also

`char` | `isstrprop` | `cellstr` | `ischar` | `isletter` | `isspace` |  
`iscellstr` | `sprintf` | `sscanf` | `text` | `input`

## Concepts

- “Cell Arrays of Strings”

**Purpose** Join strings in cell array into single string

**Syntax**

```
str = strjoin(C)
str = strjoin(C,delimiter)
```

**Description** `str = strjoin(C)` constructs the string, `str`, by linking each string in the cell array, `C`, with a single space.

`str = strjoin(C,delimiter)` constructs the string, `str`, by linking each string of `C` with the elements in `delimiter`.

## Input Arguments

### **C - Input text**

1-by-n cell array of strings

Input text, specified as a 1-by-n cell array of strings. Each element in the cell array must contain a single string in a single row.

**Example:** {'The', 'rain', 'in', 'Spain'}

### **Data Types**

cell

### **delimiter - Delimiting characters**

string | 1-by-n cell array of strings

Delimiting characters, specified as a single string or a 1-by-n cell array of strings.

- If `delimiter` is a single string, then `strjoin` forms `str` by inserting `delimiter` between each element of `C`. The `delimiter` input can include any of these escape sequences:

<code>\\</code>	Backslash
<code>\0</code>	Null
<code>\a</code>	Alarm
<code>\b</code>	Backspace

# strjoin

---

<code>\f</code>	Form feed
<code>\n</code>	New line
<code>\r</code>	Carriage return
<code>\t</code>	Horizontal tab
<code>\v</code>	Vertical tab

- If `delimiter` is a cell array of strings, then it must contain one fewer element than `C`. Each element in the cell array must contain a single string in a single row. `strjoin` forms `str` by interleaving the elements of `delimiter` and `C`. All characters in `delimiter` are inserted as literal text, and escape sequences are not supported.

**Example:** `' , '`

**Example:** `{ ' , ' , ' ' }`

## Data Types

`char` | `cell`

## Examples

### Join List of Words with Whitespace

Join individual strings in a cell array of strings, `C`, with a single space.

```
C = {'one', 'two', 'three'};
str = strjoin(C)
```

```
str =
```

```
one two three
```

### Join Cell Array of Strings

```
C = {'Newton', 'Gauss', 'Euclid', 'Lagrange'};
str = strjoin(C, ', ')
```

```
str =
```

```
Newton, Gauss, Euclid, Lagrange
```

### **Join Strings with Multiple Different Delimiters**

Specify multiple different delimiters in a cell array of strings. The delimiter cell array must have one fewer element than C.

```
C = {'one', 'two', 'three'};
str = strjoin(C, {' + ', ' = '})
```

```
str =
```

```
one + two = three
```

### **See Also**

[strsplit](#) | [strcat](#) | [cellstr](#) | [regexp](#)

# strjust

---

**Purpose** Justify character array

**Syntax**

```
T = strjust(S)
T = strjust(S, 'right')
T = strjust(S, 'left')
T = strjust(S, 'center')
```

**Description** T = strjust(S) or T = strjust(S, 'right') returns a right-justified version of the character array S.

T = strjust(S, 'left') returns a left-justified version of S.

T = strjust(S, 'center') returns a center-justified version of S.

**See Also** deblank | strtrim

**Purpose** Find possible matches for string

---

**Note** `strmatch` is not recommended. Use `strncmp` or `validatestring`, depending on your requirements, instead. `strncmp` returns the numeric index of all array elements that begin with the specified string, whereas `validatestring` returns a single string that represents the best match to the specified string. See Example 2, below.

To find an exact match for a string, use `strcmp`.

---

**Syntax**

```
x = strmatch(str, strarray)
x = strmatch(str, strarray, 'exact')
```

**Description**

`x = strmatch(str, strarray)` looks through the rows of the character array or cell array of strings `strarray` to find strings that begin with the text contained in `str`, and returns the matching row indices. If `strmatch` does not find `str` in `strarray`, `x` is an empty matrix (`[]`). Any trailing space characters in `str` or `strarray` are ignored when matching. `strmatch` is fastest when `strarray` is a character array.

`x = strmatch(str, strarray, 'exact')` compares `str` with each row of `strarray`, looking for an exact match of the entire strings. Any trailing space characters in `str` or `strarray` are ignored when matching.

**Examples** **Example 1**

The statement

```
x = strmatch('max', char('max', 'minimax', 'maximum'))
```

returns `x = [1; 3]` since rows 1 and 3 begin with 'max'. The statement

```
x = strmatch('max', char('max', 'minimax', 'maximum'),'exact')
```

returns `x = 1`, since only row 1 matches 'max' exactly.

## Example 2

This example shows how to replace use of the `strmatch` function with `validatestring` or `strncmp`.

To start with, use `strmatch` to return the index of those elements for which there is a match:

```
list = {'max', 'minimax', 'maximum', 'max'}
x = strmatch('max',list)
x =
 1
 3
 4
```

`validatestring` returns the string representing the best match. If multiple or no matches exist, this statement would return an error:

```
list = {'max', 'minimax', 'maximum', 'max'};
x = validatestring('max', list)
x =
 max
```

`strncmp` returns a logical array indicating which strings match the specified string:

```
list = {'max', 'minimax', 'maximum', 'max'};
x = strncmp('max', list, 3)
x =
 1 0 1 1
```

If you prefer that MATLAB return the numeric indices of `list`, use `find` as follows:

```
list = {'max', 'minimax', 'maximum', 'max'}
x = find(strncmp(list, 'max', 3))
```



If your input to `strmatch` is a character matrix, then first convert the matrix to a cell array using `cellstr`. Then, pass the output from `cellstr` to `strncmp` or `validatestring`

## See Also

`strcmp` | `strcmpi` | `strncmp` | `strncmpi` | `strfind` | `regexp` | `regexp`  
| `regexprep`

# strncmp

---

**Purpose** Compare first *n* characters of strings (case sensitive)

**Syntax**  
TF = strncmp(string,string,n)  
TF = strncmp(string,cellstr,n)  
TF = strncmp(cellstr,cellstr,n)

**Description** TF = strncmp(string,string,n) compares the first *n* characters of two strings for equality. The function returns a scalar logical 1 for equality, or scalar logical 0 for inequality.

TF = strncmp(string,cellstr,n) compares the first *n* characters of a string with the first *n* characters of each element of a cell array of strings. The function returns a logical array the same size as the *cellstr* input in which logical 1 represents equality. The order of the first two input arguments is not important.

TF = strncmp(cellstr,cellstr,n) compares each element of one cell array of strings with the same element of the other. strncmp attempts to match only the first *n* characters of these strings. The function returns a logical array the same size as either input array.

- Tips**
- The strncmp function is intended for comparison of character data. When used to compare numeric data, it returns logical 0.
  - Use strncmpi for case-insensitive string comparisons.
  - Any leading and trailing blanks in either of the strings are explicitly included in the comparison.
  - The value returned by strncmp is not the same as the C language convention.
  - strncmp supports international character sets.

**Input Arguments**

**string**  
Single character string or *n*-by-1 array of strings.

**cellstr**

Cell array of strings.

**n**

Maximum number of characters to compare. Must be a scalar, integer-valued double.

## **Output Arguments**

**TF**

When both inputs are character arrays, TF is a scalar logical value. This value is logical 1 (true) if the size and content of both arrays are equal, and logical 0 (false) if they are not.

When either or both inputs are a cell array of strings, TF is an array of logical ones and zeros. This array is the same size as the input cell array(s), and contains logical 1 (true) for those elements of the input arrays that are a match, and logical 0 (false) for those elements that are not.

## **Examples**

Before trying the `strncmp` function, use `strcmp` to perform a simple comparison of the two input strings. Because only the first 13 characters are the same, `strcmp` returns logical 0:

```
strcmp('Kansas City, KS', 'Kansas City, MO')
ans =
 0
```

Do the comparison again, but this time using `strncmp` and specifying the number of characters to compare:

```
chars2compare = length('Kansas City, KS') - 2
ans =
 13
strncmp('Kansas City, KS', 'Kansas City, MO', chars2compare)
ans =
 1
```

---

# strncmp

---

From a list of 10 MATLAB functions, find those that apply to using a camera:

```
function_list = {'calendar' 'case' 'camdolly' 'circshift' ...
 'caxis' 'camtarget' 'cast' 'camorbit' ...
 'callib' 'cart2sph'};
```

```
strncmp(function_list, 'cam', 3)
ans =
 0 0 1 0 0 1 0 1 0 0
```

```
function_list{strncmp(function_list, 'cam', 3)}
ans =
 camdolly
ans =
 camtarget
ans =
 camorbit
```

---

Create two 5-by-10 string arrays `str1` and `str2` that are equal, except for the element at row 4, column 3. Using linear indexing, this is element 14:

```
str1 = ['AAAAAAAAA'; 'BBBBBBBBBB'; 'CCCCCCCCC'; ...
 'DDDDDDDDD'; 'EEEEEEEEEE']
```

```
str1 =
 AAAAAAAAAA
 BBBBBBBBBB
 CCCCCCCCCC
 DDDDDDDDDD
 EEEEEEEEEE
```

```
str2 = str1;
str2(4,3) = '-'
str2 =
 AAAAAAAAAA
```

```
BBBBBBBBBB
CCCCCCCCC
DD-DDDDDD
EEEEEEEEEE
```

Because MATLAB compares the arrays in linear order (that is, column by column rather than row by row), `strncmp` finds only the first 13 elements to be the same:

```
str1 A B C D E A B C D E A B C D E
str2 A B C D E A B C D E A B C - E
 |
 element 14
```

```
strncmp(str1, str2, 13)
ans =
 1
```

```
strncmp(str1, str2, 14)
ans =
 0
```

## See Also

`strcmp` | `strncmpi` | `strcmpi` | `strfind` | `regexp` | `regexpi`

# strncmpi

---

**Purpose** Compare first *n* characters of strings (case insensitive)

**Syntax**  
TF = strncmpi(string,string,n)  
TF = strncmpi(string,cellstr,n)  
TF = strncmpi(cellstr,cellstr,n)

**Description** TF = strncmpi(string,string,n) compares the first *n* characters of two strings for equality, ignoring any differences in letter case. The function returns a scalar logical 1 for equality, or scalar logical 0 for inequality.

TF = strncmpi(string,cellstr,n) compares the first *n* characters of a string with the first *n* characters of each element of a cell array of strings, ignoring letter case. The function returns a logical array the same size as the *cellstr* input in which logical 1 represents equality. The order of the input arguments is not important.

TF = strncmpi(cellstr,cellstr,n) compares each element of one cell array of strings with the same element of the other, ignoring letter case. strncmpi attempts to match only the first *n* characters of these strings. The function returns a logical array the same size as either input array.

- Tips**
- The strncmpi function is intended for comparison of character data. When used to compare numeric data, it returns logical 0.
  - Use strcmp for case-sensitive string comparisons.
  - Any leading and trailing blanks in either of the strings are explicitly included in the comparison.
  - The value returned by strncmpi is not the same as the C language convention.
  - strncmpi supports international character sets.

**Input Arguments** **string**  
A single character string or *n*-by-1 array of strings.

**cellstr**

A cell array of strings.

**n**

Maximum number of characters to compare. Must be a scalar, integer-valued double.

**Output Arguments****TF**

When both inputs are character arrays, TF is a scalar logical value. This value is logical 1 (**true**) if the size and content of both arrays are equal, and logical 0 (**false**) if they are not.

When either or both inputs are a cell array of strings, TF is an array of logical ones and zeros. This array is the same size as the input cell array(s), and contains logical 1 (**true**) for those elements of the input arrays that are a match, and logical 0 (**false**) for those elements that are not.

**Examples**

From a list of 10 MATLAB functions, find those that apply to using a camera. Do the comparison without sensitivity to letter case:

```
function_list = {'calendar' 'case' 'camdolly' 'circshift' ...
 'caxis' 'Camtarget' 'cast' 'camorbit' ...
 'callib' 'cart2sph'};
```

```
strncmpi(function_list, 'CAM', 3)
```

```
ans =
```

```
 0 0 1 0 0 1 0 1 0 0
```

```
function_list{strncmpi(function_list, 'CAM', 3)}
```

```
ans =
```

```
 camdolly
```

```
ans =
```

```
 Camtarget
```

```
ans =
```

```
 camorbit
```

# strncmpi

---

## See Also

`strcmpi` | `strncmp` | `strcmp` | `strfind` | `regexp` | `regexp`



**Purpose** Read formatted data from string

---

**Note** strread is not recommended. Use textscan instead.

---

## Syntax

```
A = strread('str')
[A, B, ...] = strread('str')
[A, B, ...] = strread('str', 'format')
[A, B, ...] = strread('str', 'format', N)
[A, B, ...] = strread('str', 'format', N, param, value, ...)
```

## Description

`A = strread('str')` reads numeric data from input string `str` into a 1-by-`N` vector `A`, where `N` equals the number of whitespace-separated numbers in `str`. Use this form only with strings containing numeric data. See “Example 1” on page 1-6651 below.

`[A, B, ...] = strread('str')` reads numeric data from the string input `str` into scalar output variables `A`, `B`, and so on. The number of output variables must equal the number of whitespace-separated numbers in `str`. Use this form only with strings containing numeric data. See “Example 2” on page 1-6652 below.

`[A, B, ...] = strread('str', 'format')` reads data from `str` into variables `A`, `B`, and so on using the specified `format`. The number of output variables `A`, `B`, etc. must be equal to the number of format specifiers (e.g., `%s` or `%d`) in the `format` argument. You can read all of the data in `str` to a single output variable as long as you use only one format specifier in the command. See “Example 4” on page 1-6652 and “Example 5” on page 1-6653 below.

The table [Formats for strread](#) on page 1-6648 lists the valid format specifiers. More information on using formats is available under “Formats” on page 1-6651 in the “Tips” on page 1-6650 section below.

`[A, B, ...] = strread('str', 'format', N)` reads data from `str` using the format string `N` times, where `N` is an integer greater than zero. If `N` is -1, `strread` reads the entire string. When `str` contains

# strread

only numeric data, you can set `format` to the empty string ( `' '` ). See “Example 3” on page 1-6652 below.

`[A, B, ...] = strread('str', 'format', N, param, value, ...)` customizes `strread` using `param/value` pairs, as listed in the table Parameters and Values for `strread` on page 1-6649 below. When `str` contains only numeric data, you can set `format` to the empty string ( `' '` ). The `N` argument is optional and may be omitted entirely. See “Example 7” on page 1-6654 below.

## Formats for strread

Format	Action	Output
Literals (ordinary characters)	Ignore the matching characters. For example, in a string that has <code>Dept</code> followed by a number (for department number), to skip the <code>Dept</code> and read only the number, use <code>'Dept'</code> in the format string.	None
<code>%d</code>	Read a signed integer value.	Double array
<code>%u</code>	Read an integer value.	Double array
<code>%f</code>	Read a floating-point value.	Double array
<code>%s</code>	Read a white-space separated string.	Cell array of strings
<code>%q</code>	Read a double quoted string, ignoring the quotes.	Cell array of strings
<code>%c</code>	Read characters, including white space.	Character array
<code>%[...]</code>	Read the longest string containing characters specified in the brackets.	Cell array of strings

**Formats for stringstream (Continued)**

<b>Format</b>	<b>Action</b>	<b>Output</b>
%[ ^... ]	Read the longest nonempty string containing characters that are not specified in the brackets.	Cell array of strings
%*...	Ignore the characters following *. See “Example 8” on page 1-6654 below.	No output
%w...	Read field width specified by w. The %f format supports %w.pf, where w is the field width and p is the precision.	

**Parameters and Values for stringstream**

<b>param</b>	<b>value</b>	<b>Action</b>
whitespace	Any from the list below: \b Backspace \n New line \r Carriage return \t Horizontal tab \\ Backslash %% Percent sign ' Single quotation mark	Treats vector of characters, *, as white space. Default is \b\r\n\t.
delimiter	Delimiter character	Specifies delimiter character. Default is one or more whitespace characters.
expchars	Exponent characters	Default is eEdD.

## Parameters and Values for stream (Continued)

param	value	Action
bufsize	Positive integer	Specifies the maximum string length, in bytes. Default is 4095.
commentstyle	matlab	Ignores characters after %.
commentstyle	shell	Ignores characters after #.
commentstyle	c	Ignores characters between /* and */.
commentstyle	c++	Ignores characters after //.
emptyvalue	Value to return for empty numeric fields in delimited files	Default is NaN.

### Tips

If you terminate the input string with a newline character (`\n`), `stream` returns arrays of equal size by padding arrays of lesser size with the `emptyvalue` character:

```
[A,B,C] = stream(sprintf('5,7,1,9\n'),'%d%d%d', ...
 'delimiter', ',', 'emptyvalue',NaN)
A =
 5
 9
B =
 7
 NaN
C =
 1
 NaN
```

If you remove the `\n` from the input string of this example, array `A` continues to be a 2-by-1 array, but `B` and `C` are now 1-by-1.

### Delimiters

If your data uses a character other than a space as a delimiter, you must use the `strread` parameter `'delimiter'` to specify the delimiter. For example, if the string `str` used a semicolon as a delimiter, you would use this command:

```
[names, types, x, y, answer] = strread(str, '%s %s %f ...
 %d %s', 'delimiter', ';');
```

### Formats

The format string determines the number and types of return arguments. The number of return arguments must match the number of conversion specifiers in the format string.

The `strread` function continues reading `str` until the entire string is read. If there are fewer format specifiers than there are entities in `str`, `strread` reapplies the format specifiers, starting over at the beginning. See “Example 5” on page 1-6653 below.

The format string supports a subset of the conversion specifiers and conventions of the C language `fscanf` routine. White-space characters in the format string are ignored.

### Preserving White-Space

If you want to preserve leading and trailing spaces in a string, use the `whitespace` parameter as shown here:

```
str = ' An example of preserving spaces ';

strread(str, '%s', 'whitespace', '')
ans =
 ' An example of preserving spaces '
```

## Examples

### Example 1

Read numeric data into a 1-by-5 vector:

# strread

---

```
a = strread('0.41 8.24 3.57 6.24 9.27')
a =
 0.4100 8.2400 3.5700 6.2400 9.2700
```

## Example 2

Read numeric data into separate scalar variables:

```
[a b c d e] = strread('0.41 8.24 3.57 6.24 9.27')
a =
 0.4100
b =
 8.2400
c =
 3.5700
d =
 6.2400
e =
 9.2700
```

## Example 3

Read the only first three numbers in the string, also formatting as floating point:

```
a = strread('0.41 8.24 3.57 6.24 9.27', '%4.2f', 3)
a =
 0.4100
 8.2400
 3.5700
```

## Example 4

Truncate the data to one decimal digit by specifying format `%3.1f`. The second specifier, `%*1d`, tells `strread` not to read in the remaining decimal digit:

```
a = strread('0.41 8.24 3.57 6.24 9.27', '%3.1f %*1d')
a =
```

```
0.4000
8.2000
3.5000
6.2000
9.2000
```

## Example 5

Read six numbers into two variables, reusing the format specifiers:

```
[a b] = strread('0.41 8.24 3.57 6.24 9.27 3.29', '%f %f')
```

```
a =
 0.4100
 3.5700
 9.2700
b =
 8.2400
 6.2400
 3.2900
```

## Example 6

Read string and numeric data to two output variables. Ignore commas in the input string:

```
str = 'Section 4, Page 7, Line 26';

[name value] = strread(str, '%s %d,')
name =
 'Section'
 'Page'
 'Line'
value =
 4
 7
 26
```

## Example 7

Read the string used in the last example, but this time delimiting with commas instead of spaces:

```
str = 'Section 4, Page 7, Line 26';

[a b c] = strread(str, '%s %s %s', 'delimiter', ',')
a =
 'Section 4'
b =
 'Page 7'
c =
 'Line 26'
```

## Example 8

Read selected portions of the input string:

```
str = '<table border=5 width="100%" cellpadding=0>';

[border width space] = strread(str, ...
 '%*s*s %c %*s "%4s" %*s %c', 'delimiter', '= ')
border =
 5
width =
 '100%'
space =
 0
```

## Example 9

Read the string into two vectors, restricting the Answer values to T and F. Also note that two delimiters (comma and space) are used here:

```
str = 'Answer_1: T, Answer_2: F, Answer_3: F';

[a b] = strread(str, '%s %[TF]', 'delimiter', ', ', ' ')
a =
 'Answer_1:'
```



```
 'Answer_2: '
 'Answer_3: '
b =
 'T'
 'F'
 'F'
```

## See Also

[textscan](#) | [sscanf](#)

# strrep

---

**Purpose** Find and replace substring

**Syntax** `modifiedStr = strrep(origStr, oldSubstr, newSubstr)`

**Description** `modifiedStr = strrep(origStr, oldSubstr, newSubstr)` replaces all occurrences of the string `oldSubstr` within string `origStr` with the string `newSubstr`.

- Tips**
- `strrep` accepts input combinations of single strings, strings in scalar cells, and same-sized cell arrays of strings. If any inputs are cell arrays, `strrep` returns a cell array.
  - The `strrep` function does not find empty strings for replacement. That is, when `origStr` and `oldSubstr` both contain the empty string (''), `strrep` does not replace '' with the contents of `newSubstr`.
  - Before replacing strings, `strrep` finds all instances of `oldSubstr` in `origStr`, like the `strfind` function. For overlapping patterns, `strrep` performs multiple replacements. See the final example in the Examples section.

## Examples

Replace text in a character array:

```
claim = 'This is a good example.';
new_claim = strrep(claim, 'good', 'great')
```

MATLAB returns:

```
new_claim =
This is a great example.
```

---

Replace text in a cell array:

```
c_files = {'c:\cookies.m'; ...
 'c:\candy.m'; ...
 'c:\calories.m'};
d_files = strrep(c_files, 'c:', 'd:')
```

MATLAB returns:

```
d_files =
 'd:\cookies.m'
 'd:\candy.m'
 'd:\calories.m'
```

---

Replace text in a cell array with values in a second cell array:

```
missing_info = {'Start: __'; ...
 'End: __'};

dates = {'01/01/2001'; ...
 '12/12/2002'};
```

```
complete = strrep(missing_info, '__', dates)
```

MATLAB returns:

```
complete =
 'Start: 01/01/2001'
 'End: 12/12/2002'
```

---

Compare the use of `strrep` and `regexprep` to replace a string with a repeated pattern:

```
repeats = 'abc 2 def 22 ghi 222 jkl 2222';
indices = strfind(repeats, '22')

using_strrep = strrep(repeats, '22', '*')
using_regexprep = regexprep(repeats, '22', '*')
```

MATLAB returns:

```
indices =
 11 18 19 26 27 28
```

# strrep

---

```
using_strrep =
abc 2 def * ghi ** jkl ***
```

```
using_regexprep =
abc 2 def * ghi *2 jkl **
```

## See Also

[strfind](#) | [regexprep](#)

**Purpose** Split string at specified delimiter

**Syntax**

```
C = strsplit(str)
C = strsplit(str,delimiter)
C = strsplit(str,delimiter,Name,Value)

[C,matches] = strsplit(__)
```

**Description** C = strsplit(str) splits the string, str, at whitespace into the cell array of strings, C. A whitespace character is equivalent to any sequence in the set {' ', '\f', '\n', '\r', '\t', '\v'}.

C = strsplit(str,delimiter) splits str at the delimiters specified by delimiter.

C = strsplit(str,delimiter,Name,Value) specifies additional delimiter options using one or more name-value pair arguments.

[C,matches] = strsplit( \_\_ ) additionally returns a cell array of strings, matches, using any of the input arguments in the previous syntaxes. matches contains all occurrences of delimiters upon which strsplit splits str.

## Input Arguments

**str - Input text**  
string

Input text, specified as a string.

**Data Types**  
char

**delimiter - Delimiting characters**  
string | 1-by-n cell array of strings

# strsplit

---

Delimiting characters, specified as a single string or a 1-by-n cell array of strings. Strings specified in `delimiter` do not appear in the string fragments of the output `C`.

Specify multiple delimiters in a cell array of strings. Each element of the cell array must contain a single string in a single row. The `strsplit` function splits `str` on the elements of `delimiter` in the order in which they appear in the cell array.

`delimiter` can include the following escape sequences:

<code>\\</code>	Backslash
<code>\0</code>	Null
<code>\a</code>	Alarm
<code>\b</code>	Backspace
<code>\f</code>	Form feed
<code>\n</code>	New line
<code>\r</code>	Carriage return
<code>\t</code>	Horizontal tab
<code>\v</code>	Vertical tab

**Example:** `' , '`

**Example:** `{ ' - ' , ' , ' }`

## Data Types

char | cell

## Name-Value Pair Arguments

Specify optional comma-separated pairs of `Name`, `Value` arguments. `Name` is the argument name and `Value` is the corresponding value. `Name` must appear inside single quotes (`' '`). You can specify several name and value pair arguments in any order as `Name1, Value1, ..., NameN, ValueN`.

**Example:** 'DelimiterType', 'RegularExpression' instructs strsplit to treat delimiter as a regular expression.

### 'CollapseDelimiters' - Multiple delimiter handling

1 (true) (default) | 0 (false)

Multiple delimiter handling, specified as the comma-separated pair consisting of 'CollapseDelimiters' and either true or false. If true, then consecutive delimiters in str are treated as one. If false, then consecutive delimiters are treated as separate delimiters, resulting in empty string '' elements between matched delimiters.

**Example:** 'CollapseDelimiters', true

### 'DelimiterType' - Delimiter type

'Simple' (default) | 'RegularExpression'

Delimiter type, specified as the comma-separated pair consisting of 'DelimiterType' and one of the following strings.

'Simple'	Except for escape sequences, strsplit treats delimiter as a literal string.
'RegularExpression'	strsplit treats delimiter as a regular expression.

In both cases, delimiter can include escape sequences.

## Output Arguments

### C - Parts of original string

cell array of strings

Parts of the original string, returned as a cell array of strings. C always contains one more element than matches contains. Consequently, if the original string, str, ends with a delimiter, then the last cell in C contains an empty string.

### matches - Identified delimiters

cell array of strings

# strsplit

---

Identified delimiters, returned as a cell array of strings. `matches` always contains one fewer element than output `C` contains.

## Examples

### Split String on Whitespace

```
str = 'The rain in Spain.';
C = strsplit(str)
```

```
C =
```

```
 'The' 'rain' 'in' 'Spain.'
```

`C` is a cell array containing 4 strings.

### Split String of Values on Specific Delimiter

Split a string of comma-separated values.

```
data = '1.21, 1.985, 1.955, 2.015, 1.885';
C = strsplit(data,', ')
```

```
C =
```

```
 '1.21' '1.985' '1.955' '2.015' '1.885'
```

Split a string of values, `data`, which contains the units `m/s` with an arbitrary number of white-space on either side of the text. The regular expression, `\s*`, matches any white-space character appearing zero or more times.

```
data = '1.21m/s1.985m/s 1.955 m/s2.015 m/s 1.885m/s';
[C,matches] = strsplit(data,'\s*m/s\s*',...
 'DelimiterType','RegularExpression')
```

```
C =
```

```
 '1.21' '1.985' '1.955' '2.015' '1.885' ''
```



```

matches =

 'm/s' 'm/s ' ' m/s' ' m/s ' 'm/s'

```

In this case, the last string in `C` is empty. This empty string is the string that follows the last matched delimiter.

### Split Path String on File Separator

```

myPath = 'C:\work\matlab';
C = strsplit(myPath,'\')

C =

 'C:' 'work' 'matlab'

```

### Split Text String with Multiple Delimiters

Split a string on ' ' and 'ain', treating multiple delimiters as one. Specify multiple delimiters in a cell array of strings.

```

str = 'The rain in Spain stays mainly in the plain.';
[C,matches] = strsplit(str,{' ','ain'},'CollapseDelimiters',true)

C =

 'The' 'r' 'in' 'Sp' 'stays' 'm' 'ly' 'in'

```

```

matches =

 ' ' 'ain ' ' ' 'ain ' ' ' 'ain' ' ' ' '

```

Split the same string on whitespace and on 'ain', using regular expressions and treating multiple delimiters separately.

```

[C,matches] = strsplit(str,{'\s','ain'},'CollapseDelimiters',...
 false, 'DelimiterType','RegularExpression')

C =

```

# strsplit

---

```
'The' 'r' '' 'in' 'Sp' '' 'stays' 'm' 'ly'

matches =
'' 'ain' '' ' ' 'ain' '' ' ' 'ain' ''
```

In this case, `strsplit` treats the two delimiters separately, so empty strings appear in output `C` between the consecutively matched delimiters.

## Split Text with Multiple, Overlapping Delimiters

Split text on the strings `'`, `'` and `'`, and `'`.

```
str = 'bacon, lettuce, and tomato';
[C,matches] = strsplit(str,{' ', ',',' and '})

C =
 'bacon' 'lettuce' 'and tomato'

matches =
 ' ', ', ', ' ', ' ', ' ', ' ', ' ';
```

Because the command lists `'`, `'` first and `'`, and `'` contains `'`, `'`, the `strsplit` function splits `str` on the first delimiter and never proceeds to the second delimiter.

If you reverse the order of delimiters, `'`, and `'` takes priority.

```
str = 'bacon, lettuce, and tomato';
[C,matches] = strsplit(str,{' ', and ', ', ' '})

C =
```

```
'bacon' 'lettuce' 'tomato'
```

```
matches =
```

```
',' ' ' and '
```

## See Also

[strjoin](#) | [strfind](#) | [regexp](#)

## Concepts

- “Regular Expressions”

# strtok

---

**Purpose** Selected parts of string

**Syntax**

```
token = strtok(str)
token = strtok(str, delimiter)
[token, remain] = strtok(str, ...)
```

**Description** `token = strtok(str)` parses input string `str` from left to right, returning part or all of that string in `token`. Using the white-space character as a delimiter, the `token` output begins at the start of `str`, skipping any delimiters that might appear at the start, and includes all characters up to either the next delimiter or the end of the string. White-space characters include space (ASCII 32), tab (ASCII 9), and carriage return (ASCII 13).

The `str` argument can be a string of characters enclosed in single quotation marks, a cell array of strings each enclosed in single quotation marks, or a variable representing either of the two. If `str` is a cell array of `N` strings, then `token` is a cell array of `N` tokens, with `token{1}` derived from `str{1}`, `token{2}` from `str{2}`, and so on.

`token = strtok(str, delimiter)` is the same as the above syntax except that you specify the delimiting character(s) yourself using the `delimiter` character vector input. White-space characters are not considered to be delimiters when using this syntax unless you include them in the `delimiter` argument. If the `delimiter` input specifies more than one character, MATLAB treats each character as a separate delimiter; it does not treat the multiple characters as a delimiting string. The number and order of characters in the `delimiter` argument is unimportant. Do not use escape sequences as delimiters. For example, use `char(9)` rather than `'\t'` for tab.

`[token, remain] = strtok(str, ...)` returns in `remain` that part of `str`, if any, that follows `token`. The delimiter is included in `remain`. If no delimiters are found in the body of the input string, then the entire string (excluding any leading delimiting characters) is returned in `token`, and `remain` is an empty string (`' '`). If `str` is a cell array of strings, `token` is a cell array of tokens and `remain` is a cell array of string remainders.

## Examples

### Example 1

This example uses the default white-space delimiter. Note that space characters at the start of the string are not included in the token output, but the space character that follows token is included in remain:

```
s = ' This is a simple example.';
[token, remain] = strtok(s)
```

```
token =
This
remain =
 is a simple example.
```

### Example 2

Take a string of HTML code and break it down into segments delimited by the < and > characters. Write a while loop to parse the string and print each segment:

```
s = sprintf('%s%s%s%s', ...
'<ul class=continued><li class=continued>', ...
'<pre>token = strtok', ...
'('str', delimiter)', ...
'token = strtok('str')');
```

```
remain = s;
```

```
while true
 [str, remain] = strtok(remain, '<>');
 if isempty(str), break; end
 disp(sprintf('%s', str))
end
```

Here is the output:

```
ul class=continued
li class=continued
pre
```

# strtok

---

```
a name="13474"
/a
token = strtok('str', delimiter)
a name="13475"
/a
token = strtok('str')
```

## Example 3

Using `strtok` on a cell array of strings returns a cell array of strings in `token` and a character array in `remain`:

```
s = {'all in good time'; ...
 'my dog has fleas'; ...
 'leave no stone unturned'};

remain = s;

for k = 1:4
 [token, remain] = strtok(remain);
 token
end
```

Here is the output:

```
token =
 'all'
 'my'
 'leave'
token =
 'in'
 'dog'
 'no'
token =
 'good'
 'has'
 'stone'
token =
```

```
'time'
'fleas'
'unturned'
```

## See Also

[strfind](#) | [strncmp](#) | [strcmp](#) | [textscan](#) | [strsplit](#)

# strtrim

---

**Purpose** Remove leading and trailing white space from string

**Syntax**  
S = strtrim(str)  
C = strtrim(cstr)

**Description** S = strtrim(str) returns a copy of string str with all leading and trailing white-space characters removed. A white-space character is one for which the isspace function returns logical 1 (true).

C = strtrim(cstr) returns a copy of the cell array of strings cstr with all leading and trailing white-space characters removed from each string in the cell array.

**Examples** Remove the leading white-space characters (spaces and tabs) from str:

```
str = sprintf(' \t Remove leading white-space')
str =
 Remove leading white-space
```

```
str = strtrim(str)
str =
Remove leading white-space
```

Remove leading and trailing white-space from the cell array of strings:

```
cstr = {' Trim leading white-space';
 'Trim trailing white-space '};
```

```
cstr = strtrim(cstr)
cstr =
 'Trim leading white-space'
 'Trim trailing white-space'
```

**See Also** isspace | cellstr | deblank | strjust



**Purpose**

Create structure array

**Syntax**

```
s = struct
s = struct(field,value)
s = struct(field1,value1,...,fieldN,valueN)
s = struct([])

s = struct(obj)
```

**Description**

`s = struct` creates a scalar (1-by-1) structure with no fields.

`s = struct(field,value)` creates a structure array with the specified field and values.

- If `value` is *not* a cell array, then `s` is a scalar structure, where `s.(field) = value`.
- If `value` is a cell array, then `s` is a structure array with the same dimensions as `value`. Each element of `s` contains the corresponding element of `value`. For example, `s = struct('f',{'a','b'})` returns `s(1).f = 'a'` and `s(2).f = 'b'`.
- If `value` is an empty cell array `{}`, then `s` is an empty (0-by-0) structure.

`s = struct(field1,value1,...,fieldN,valueN)` creates a structure array with multiple fields. Any nonscalar cell arrays in the set `value1,...,valueN` must have the same dimensions.

- If none of the `value` inputs is a cell array, or all are scalar cell arrays, then `s` is a scalar structure.
- If any of the `value` inputs are nonscalar cell arrays, then `s` has the same dimensions as the nonscalar cell arrays. For any `value` that is a scalar cell array or an array of any other data type, `struct` inserts the contents of `value` in the relevant field for all elements of `s`.
- If any `value` input is an empty cell array, `{}`, then output `s` is an empty (0-by-0) structure.

# struct

---

`s = struct([])` creates an empty (0-by-0) structure with no fields.

`s = struct(obj)` creates a structure with field names and values that correspond to properties of `obj`. MATLAB does not convert `obj`, but rather creates `s` as a new structure. This structure does not retain the class information, so private, protected, and hidden properties become public fields in `s`. The `struct` function issues a warning when you use this syntax.

## Input Arguments

### field - Field name

string

Field name, specified as a string. Valid field names begin with a letter, and can contain letters, digits, and underscores. The maximum length of a field name is the value that the `namelengthmax` function returns.

### value - Values within structure field

cell array | scalar | vector | multidimensional array

Values within structure field, specified as a cell array or as a scalar, vector, or multidimensional array of any other data type.

If none of the `value` inputs is a cell array, or all of the `value` inputs are scalar cell arrays, then output `s` is a scalar structure. Otherwise, `value` inputs that are nonscalar cell arrays must have the same dimensions, and output `s` also has those dimensions. For any `value` that is a scalar cell array or an array of any other data type, `struct` inserts the contents of `value` in the relevant field for all elements of `s`.

If any `value` input is an empty cell array, {}, then output `s` is an empty structure array.

### Data Types

single | double | int8 | int16 | int32 | int64 | uint8 | uint16 | uint32 | uint64 | logical | char | struct | cell | function\_handle

**Complex Number Support:** Yes

### obj - Object

any nonfundamental class

Object of any class, except the fundamental data types such as double or char.

## Examples

### Structure with One Field

Create a nonscalar structure with one field, `f`.

```
field = 'f';
value = {'some text';
 [10, 20, 30];
 magic(5)};
s = struct(field,value)

s =
3x1 struct array with fields:
 f
```

View the contents each element.

```
s.f

ans =
some text

ans =
 10 20 30

ans =
 17 24 1 8 15
 23 5 7 14 16
 4 6 13 20 22
 10 12 19 21 3
 11 18 25 2 9
```

When you access a field of a nonscalar structure, such as `s.f`, MATLAB returns a comma-separated list. In this case, `s.f` is equivalent to `s(1).f`, `s(2).f`, `s(3).f`.

## Structure with Multiple Fields

Create a nonscalar structure with several fields.

```
field1 = 'f1'; value1 = zeros(1,10);
field2 = 'f2'; value2 = {'a', 'b'};
field3 = 'f3'; value3 = {pi, pi.^2};
field4 = 'f4'; value4 = {'fourth'};
```

```
s = struct(field1,value1,field2,value2,field3,value3,field4,value4)
```

```
s =
1x2 struct array with fields:
 f1
 f2
 f3
 f4
```

The cell arrays for `value2` and `value3` are 1-by-2, so `s` is also 1-by-2. Because `value1` is a numeric array and not a cell array, both `s(1).f1` and `s(2).f1` have the same contents. Similarly, because the cell array for `value4` has a single element, `s(1).f4` and `s(2).f4` have the same contents.

```
s(1)
```

```
ans =
 f1: [0 0 0 0 0 0 0 0 0 0]
 f2: 'a'
 f3: 3.1416
 f4: 'fourth'
```

```
s(2)
```

```
ans =
 f1: [0 0 0 0 0 0 0 0 0 0]
 f2: 'b'
 f3: 9.8696
 f4: 'fourth'
```

### Fields that Contain Cell Arrays

Create a structure with a field that contains a cell array.

```
field = 'mycell';
value = {'a','b','c'};
s = struct(field,value)

s =
 mycell: {'a' 'b' 'c'}
```

### Empty Structure Array

Create an empty structure with several fields.

```
s = struct('a', {}, 'b', {}, 'c', {})

s =
0x0 struct array with fields:
 a
 b
 c
```

Assign a value to a field in an empty structure.

```
s(1).a = 'a'

s =
 a: 'a'
 b: []
 c: []
```

### Nested Structure Array

Create a nested structure: a contains field b, which in turn contains fields c and d.

```
a.b = struct('c', {}, 'd', {})

a =
```

# struct

---

```
b: [0x0 struct]
```

View the names of the fields of nested structure a.b.

```
fieldnames(a.b)
```

```
ans =
 'c'
 'd'
```

## See Also

[isfield](#) | [table](#) | [isstruct](#) | [fieldnames](#) | [orderfields](#) | [rmfield](#)  
| [substruct](#) | [cell2struct](#) | [struct2cell](#)

## Related Examples

- “Create a Structure Array”
- “Access Data in a Structure Array”
- “Generate Field Names from Variables”

<b>Purpose</b>	Convert structure to cell array
<b>Syntax</b>	<code>c = struct2cell(s)</code>
<b>Description</b>	<p><code>c = struct2cell(s)</code> converts the <code>m</code>-by-<code>n</code> structure <code>s</code> (with <code>p</code> fields) into a <code>p</code>-by-<code>m</code>-by-<code>n</code> cell array <code>c</code>.</p> <p>If structure <code>s</code> is multidimensional, cell array <code>c</code> has size <code>[p size(s)]</code>.</p>
<b>Tips</b>	<ul style="list-style-type: none"><li>• Use <code>fieldnames</code> to obtain structure field names in the same order as <code>struct2cell</code> returns structure values.</li></ul>
<b>Examples</b>	<p>The commands</p> <pre>clear s, s.category = 'tree'; s.height = 37.4; s.name = 'birch';</pre> <p>create the structure</p> <pre>s =     category: 'tree'     height: 37.4000     name: 'birch'</pre> <p>Converting the structure to a cell array,</p> <pre>c = struct2cell(s)</pre> <pre>c =     'tree'     [37.4000]     'birch'</pre>
<b>See Also</b>	<code>cell2struct</code>   <code>struct2table</code>   <code>table2cell</code>   <code>cell</code>   <code>iscell</code>   <code>struct</code>   <code>isstruct</code>   <code>fieldnames</code>
<b>How To</b>	<ul style="list-style-type: none"><li>• dynamic field names</li></ul>

# struct2table

---

**Purpose** Convert structure array to table

**Syntax**  
`T = struct2table(S)`  
`T = struct2table(S,Name,Value)`

**Description** `T = struct2table(S)` converts the structure array, `S`, to a table, `T`. Each field of `S` becomes a variable in `T`.

`T = struct2table(S,Name,Value)` creates a table from a structure array, `S`, with additional options specified by one or more `Name,Value` pair arguments.

For example, you can specify row names to include in the table.

## Input Arguments

### **S** - Structure array

structure array

Structure array, specified as a scalar structure array.

- If `S` is a scalar structure with `n` fields, all of which have `m` rows, then `T` is an `m`-by-`n` table.
- If `S` is a nonscalar `m`-by-1 structure array with `n` fields, then `T` is an `m`-by-`n` table.

### **Name-Value Pair Arguments**

Specify optional comma-separated pairs of `Name,Value` arguments. `Name` is the argument name and `Value` is the corresponding value. `Name` must appear inside single quotes ( `' '` ). You can specify several name and value pair arguments in any order as `Name1,Value1,...,NameN,ValueN`.

**Example:** `RowNames','{ 'row1','row2','row3' }` uses the row names, `row1`, `row2`, and `row3` for the table, `T`.

### **'RowNames' - Row names for T**

`{}` (default) | cell array of nonempty, distinct strings



Row names for T, specified as the comma-separated pair consisting of 'RowNames' and a cell array of nonempty, distinct strings.

## 'AsArray' - Indicator for how to treat scalar structure

false (default) | true | 0 | 1

Indicator for how to treat scalar structure, specified as the comma-separated pair consisting of 'AsArray' and either false, true, 0, or 1.

true	struct2table converts S to a table with one row and n variables. The variables can be different sizes.
false	struct2table converts a scalar structure array with n fields into an m-by-n table. Each field must have m rows. This is the default behavior

## Output Arguments

### T - Output table

table

Output table, returned as a table. The table can store metadata such as descriptions, variable units, variable names, and row names. For more information, see [Table Properties](#).

## Examples

### Convert Scalar Structure to Table

Convert a scalar structure to a table using the default options.

Create a structure array, S.

```
S.Name = {'CLARK'; 'BROWN'; 'MARTIN'};
S.Gender = {'M'; 'F'; 'M'};
S.SystolicBP = [124; 122; 130];
S.DiastolicBP = [93; 80; 92];
```

S

S =

# struct2table

---

```
 Name: {3x1 cell}
 Gender: {3x1 cell}
 SystolicBP: [3x1 double]
 DiastolicBP: [3x1 double]
```

The scalar structure, **S**, has four fields, each with three rows.

Convert the structure array to a table.

```
T = struct2table(S)
```

```
T =
```

Name	Gender	SystolicBP	DiastolicBP
'CLARK'	'M'	124	93
'BROWN'	'F'	122	80
'MARTIN'	'M'	130	92

The structure field names in **S** become the variable names in the output table. The size of **T** is 3-by-4.

Change **Name** from a variable to row names by modifying the table property, **T.Properties.RowNames**, and then deleting the variable **Name**.

```
T.Properties.RowNames = T.Name;
T.Name = [];
```

```
T
```

```
T =
```

	Gender	SystolicBP	DiastolicBP
CLARK	'M'	124	93

```

 BROWN 'F' 122 80
 MARTIN 'M' 130 92

```

## Convert Nonscalar Structure Array to Table

Create a nonscalar structure array, S.

```

S(1,1).Name = 'CLARK';
S(1,1).Gender = 'M';
S(1,1).SystolicBP = 124;
S(1,1).DiastolicBP = 93;

```

```

S(2,1).Name = 'BROWN';
S(2,1).Gender = 'F';
S(2,1).SystolicBP = 122;
S(2,1).DiastolicBP = 80;

```

```

S(3,1).Name = 'MARTIN';
S(3,1).Gender = 'M';
S(3,1).SystolicBP = 130;
S(3,1).DiastolicBP = 92;

```

```
S
```

```
S =
```

3x1 struct array with fields:

```

 Name
 Gender
 SystolicBP
 DiastolicBP

```

S is a 3-by-1 structure array with four fields.

Convert the structure array to a table.

```
T = struct2table(S)
```

# struct2table

---

```
T =
```

Name	Gender	SystolicBP	DiastolicBP
'CLARK'	'M'	124	93
'BROWN'	'F'	122	80
'MARTIN'	'M'	130	92

The structure field names in `S` become the variable names in the output table. The size of `T` is 3-by-4.

## Treat Scalar Structure As Array

Use `'AsArray'`, `true` to create a table from a scalar structure whose fields have different numbers of rows.

Create a scalar structure, `S`, with fields `name`, `billing`, and `test`.

```
S.name = 'John Doe';
S.billing = 127.00;
S.test = [79, 75, 73; 180, 178, 177.5; 220, 210, 205];
S
```

```
S =
```

```
 name: 'John Doe'
 billing: 127
 test: [3x3 double]
```

The fields have a different number of rows. Therefore, you cannot use `struct2table(S)`, which uses `'AsArray'`, `false` by default.

Treat the scalar structure as an array and convert it to a table.

```
T = struct2table(S, 'AsArray', true)
```

```
T =
```

<u>name</u>	<u>billing</u>	<u>test</u>
'John Doe'	127	[3x3 double]

T contains one row.

## See Also

[table2struct](#) | [cell2table](#) | [array2table](#) | [table](#)

## Related Examples

- “Access Data in a Table”

# structfun

---

**Purpose** Apply function to each field of scalar structure

**Syntax**  
`[A1,...,An] = structfun(func,S)`  
`[A1,...,An] = structfun(func,S,Name,Value)`

**Description** `[A1,...,An] = structfun(func,S)` applies the function specified by function handle `func` to each field of scalar structure `S`. Output arrays `A1,...,An`, where `n` is the number of outputs from function `func`, contain the outputs from the function calls.

`[A1,...,An] = structfun(func,S,Name,Value)` calls function `func` with additional options specified by one or more `Name,Value` pair arguments. Possible values for `Name` are `'UniformOutput'` or `'ErrorHandler'`.

## Input Arguments

### **func**

Handle to a function that accepts a single input argument and returns `n` output arguments.

If function `func` corresponds to more than one function file (that is, if `func` represents a set of overloaded functions), MATLAB determines which function to call based on the class of the input arguments.

### **S**

Scalar structure.

### **Name-Value Pair Arguments**

Specify optional comma-separated pairs of `Name,Value` arguments. `Name` is the argument name and `Value` is the corresponding value. `Name` must appear inside single quotes (`' '`). You can specify several name and value pair arguments in any order as `Name1,Value1,...,NameN,ValueN`.

### **'UniformOutput'**

Logical value, as follows:

- `true` (1) Indicates that for all inputs, each output from function `func` is a cell array or a scalar value that is always of the same type and size. The `structfun` function combines the outputs in arrays `A1, ..., An`, where `n` is the number of function outputs. Each output array is of the same type as the individual function outputs.
- `false` (0) Requests that the `structfun` function combine the outputs into scalar structures `A1, ..., An`, with the same fields as input structure `S`. The outputs of function `func` can be of any size or type.

**Default:** `true`

## 'ErrorHandler'

Handle to a function that catches any errors that occur when MATLAB attempts to execute function `func`. Define this function so that it rethrows the error or returns valid outputs for function `func`.

MATLAB calls the specified error-handling function with two input arguments:

- A structure with these fields:

<code>identifier</code>	Error identifier.
<code>message</code>	Error message text.
<code>index</code>	Linear index corresponding to the element of the input cell array at the time of the error.

- The set of input arguments to function `func` at the time of the error.

## Output Arguments

### `A1, ..., An`

Arrays that collect the `n` outputs from function `func`.

If `UniformOutput` is `true` (the default):

# structfun

---

- The individual outputs from function `func` must be scalar values (numeric, logical, character, or structure) or cell arrays.
- The class of a particular output argument must be the same for each input. The class of the corresponding output array is the same as the class of the individual outputs from function `func`.
- Each array `A` is a column vector whose length equals the number of fields in `S`. The `structfun` function applies function `func` to the fields of `S` in the same order as that returned by the `fieldnames` function.

If `UniformOutput` is `false`, each array `A` is a scalar structure with the same fields as input `S`.

## Examples

Create a scalar structure, and count the number of characters in each field.

```
s.f1 = 'Sunday';
s.f2 = 'Monday';
s.f3 = 'Tuesday';
s.f4 = 'Wednesday';
s.f5 = 'Thursday';
s.f6 = 'Friday';
s.f7 = 'Saturday';
```

```
lengths = structfun(@numel, s)
```

---

Shorten the text in each field of `s`, created in the previous example. Because the output is nonscalar, set `UniformOutput` to `false`.

```
shortNames = structfun(@(x) (x(1:3)), s, 'UniformOutput', false)
```

The syntax `@(x)` creates an anonymous function.

---

Define and call a custom error handling function.

```
function result = errorfun(errorinfo, field)
```



```
 warning(errorinfo.identifier, errorinfo.message);
 result = NaN;
 end

mystruct.f1 = 'text';
myresult = structfun(@(x) x^2, mystruct, 'ErrorHandler', @errorfun)
```

## See Also

[cellfun](#) | [arrayfun](#) | [function\\_handle](#) | [cell2mat](#) | [spfun](#)

## Tutorials

- “Anonymous Functions”

# strvcat

---

**Purpose** Concatenate strings vertically

---

**Note** `strvcat` is not recommended. Use `char` instead. Unlike `strvcat`, the `char` function does not ignore empty strings.

---

**Syntax** `S = strvcat(t1, t2, t3, ...)`  
`S = strvcat(c)`

**Description** `S = strvcat(t1, t2, t3, ...)` forms the character array `S` containing the text strings (or string matrices) `t1, t2, t3, ...` as rows. Spaces are appended to each string as necessary to form a valid matrix. Empty arguments are ignored.

`S = strvcat(c)` when `c` is a cell array of strings, passes each element of `c` as an input to `strvcat`. Empty strings in the input are ignored.

**Tips** If each text parameter, `ti`, is itself a character array, `strvcat` appends them vertically to create arbitrarily large string matrices.

**Examples** The command `strvcat('Hello', 'Yes')` is the same as `['Hello'; 'Yes']`, except that `strvcat` performs the padding automatically.

```
t1 = 'first'; t2 = 'string'; t3 = 'matrix'; t4 = 'second';
```

```
S1 = strvcat(t1, t2, t3) S2 = strvcat(t4, t2, t3)
```

```
S1 = S2 =
```

```
first second
string string
matrix matrix
```

```
S3 = strvcat(S1, S2)
```

```
S3 =
```

first  
string  
matrix  
second  
string  
matrix

## See Also

strcat | cat | vertcat | horzcat | int2str | mat2str | num2str  
| strings | special character

# sub2ind

---

**Purpose** Convert subscripts to linear indices

**Syntax** `linearInd = sub2ind(matrixSize, rowSub, colSub)`  
`linearInd = sub2ind(arraySize, dim1Sub, dim2Sub, dim3Sub, ...)`

**Description** `linearInd = sub2ind(matrixSize, rowSub, colSub)` returns the linear index equivalent to the row and column subscripts `rowSub` and `colSub` for a matrix of size `matrixSize`. The `matrixSize` input is a 2-element vector that specifies the number of rows and columns in the matrix as `[nRows, nCols]`. The `rowSub` and `colSub` inputs are positive, whole number scalars or vectors that specify one or more row-column subscript pairs for the matrix. Example 3 demonstrates the use of vectors for the `rowSub` and `colSub` inputs.

`linearInd = sub2ind(arraySize, dim1Sub, dim2Sub, dim3Sub, ...)` returns the linear index equivalent to the specified subscripts for each dimension of an N-dimensional array of size `arraySize`. The `arraySize` input is an n-element vector that specifies the number of dimensions in the array. The `dimNSub` inputs are positive, whole number scalars or vectors that specify one or more row-column subscripts for the matrix.

All subscript inputs can be single, double, or any integer type. The `linearInd` output is always of class double.

If needed, `sub2ind` assumes that unspecified trailing subscripts are 1. See Example 2, below.

## Examples

### Example 1

This example converts the subscripts (2, 1, 2) for three-dimensional array A to a single linear index. Start by creating a 3-by-4-by-2 array A:

```
rng(0,'twister'); % Initialize random number generator.
A = rand(3, 4, 2)
```

```
A(:,:,1) =
 0.8147 0.9134 0.2785 0.9649
```

```

 0.9058 0.6324 0.5469 0.1576
 0.1270 0.0975 0.9575 0.9706
A(:, :, 2) =
 0.9572 0.1419 0.7922 0.0357
 0.4854 0.4218 0.9595 0.8491
 0.8003 0.9157 0.6557 0.9340

```

Find the linear index corresponding to (2, 1, 2):

```

linearInd = sub2ind(size(A), 2, 1, 2)
linearInd =
 14

```

Make sure that these agree:

```

A(2, 1, 2) A(14)
ans = and =
 0.4854 0.4854

```

## Example 2

Using the 3-dimensional array A defined in the previous example, specify only 2 of the 3 subscript arguments in the call to sub2ind. The third subscript argument defaults to 1.

The command

```

linearInd = sub2ind(size(A), 2, 4)
ans =
 11

```

is the same as

```

linearInd = sub2ind(size(A), 2, 4, 1)
ans =
 11

```

## Example 3

Using the same 3-dimensional input array A as in Example 1, accomplish the work of five separate `sub2ind` commands with just one.

Replace the following commands:

```
sub2ind(size(A), 3, 3, 2);
sub2ind(size(A), 2, 4, 1);
sub2ind(size(A), 3, 1, 2);
sub2ind(size(A), 1, 3, 2);
sub2ind(size(A), 2, 4, 1);
```

with a single command:

```
sub2ind(size(A), [3 2 3 1 2], [3 4 1 3 4], [2 1 2 2 1])
ans =
 21 11 15 19 11
```

Verify that these linear indices access the same array elements as their subscripted counterparts:

```
[A(3,3,2), A(2,4,1), A(3,1,2), A(1,3,2), A(2,4,1)]
ans =
 0.6557 0.1576 0.8003 0.7922 0.1576
```

```
A([21, 11, 15, 19, 11])
ans =
 0.6557 0.1576 0.8003 0.7922 0.1576
```

## See Also

`ind2sub` | `find` | `size`

**Purpose**

Create axes in tiled positions

**Syntax**

```
subplot(m,n,p)
subplot(m,n,p,'replace')
subplot(m,n,p,'align')
subplot('Position',positionVector)
subplot(__ ,Name,Value)
```

```
h = subplot(__)
```

```
subplot(h)
```

**Description**

`subplot(m,n,p)` divides the current figure into an *m*-by-*n* grid and creates an axes in the grid position specified by *p*. MATLAB numbers its grids by row, such that the first grid is the first column of the first row, the second grid is the second column of the first row, and so on.

`subplot(m,n,p,'replace')` deletes any existing axes in grid location *p* and creates a new axes.

`subplot(m,n,p,'align')` creates a new axes so that the plot boxes are aligned. This is the default behavior.

`subplot('Position',positionVector)` creates a new axes at the position specified by `positionVector`. The `positionVector` is a four-element vector of the form `[left,bottom,width,height]`, such that the entries are normalized values between 0.0 to 1.0. If the position vector specifies an axes that overlaps any previous axes, then the new axes replaces the existing ones.

`subplot( __ ,Name,Value)` specifies properties for the axes using any of the input argument combinations in the previous syntaxes and one or more `Name,Value` pair arguments.

# subplot

---

`h = subplot( __ )` returns the handle to the axes created by the `subplot` function.

`subplot(h)` makes the axes with handle `h` the current axes for subsequent plotting commands.

## Input Arguments

### **m - Number of grid rows**

1 (default) | positive integer

Number of grid rows, specified as a positive integer.

### **Data Types**

single | double

### **n - Number of grid columns**

1 (default) | positive integer

Number of grid columns, specified as a positive integer.

### **Data Types**

single | double

### **p - Grid position for new axes**

positive integer | vector

Grid position for the new axes, specified as a positive integer or a vector of positive integers.

- If `p` is a positive integer, then `subplot` creates a new axes in grid location `p`.
- If `p` is a vector of positive integers, then `subplot` creates a new axes that spans the grid locations listed in `p`. For example, `subplot(2,3,[2,5])` creates one axes spanning positions 2 and 5. Use `subplot(2,3,[2,6])` to create one axes spanning positions 2, 3, 5, and 6.

### **Data Types**

single | double



**positionVector - Normalized position for new axes**

four-element vector of values between 0.0 and 1.0

Normalized position for the new axes, specified as a four-element vector of values between 0.0 and 1.0 with the form `[left,bottom,width,height]`. The values are normalized with respect to the interior of the figure. The first two elements specify the position of the bottom-left corner of the axes in relation to the bottom-left corner of the figure. The last two elements specify the width and height of the new axes. Use this syntax to position an axes that does not align with grid positions.

**Example:** `[0.1, 0.1, 0.35, 0.35]`

**Data Types**

single | double

**Name-Value Pair Arguments**

Specify optional comma-separated pairs of `Name,Value` arguments. `Name` is the argument name and `Value` is the corresponding value. `Name` must appear inside single quotes (`' '`). You can specify several name and value pair arguments in any order as `Name1,Value1,...,NameN,ValueN`.

You can set any axes properties for a subplot. Some plotting functions override existing axes property settings. Execute plotting functions before specifying axes properties to avoid overriding them. For a list of axes properties see [Axes Properties](#).

**Example:** `'XGrid','on'`

**Output Arguments****h - Handle to axes object**

scalar

Handle to axes object, returned as a scalar. This is a unique identifier, which you can use to query and modify the properties of a specific axes object.

# subplot

---

## Examples

### Upper and Lower Subplots

Create a figure with two stacked subplots. Plot a sine wave in each axes.

```
x = linspace(0,10);
y1 = sin(x);
y2 = sin(5*x);
```

```
figure
subplot(2,1,1);
plot(x,y1)
```

```
subplot(2,1,2);
plot(x,y2)
```

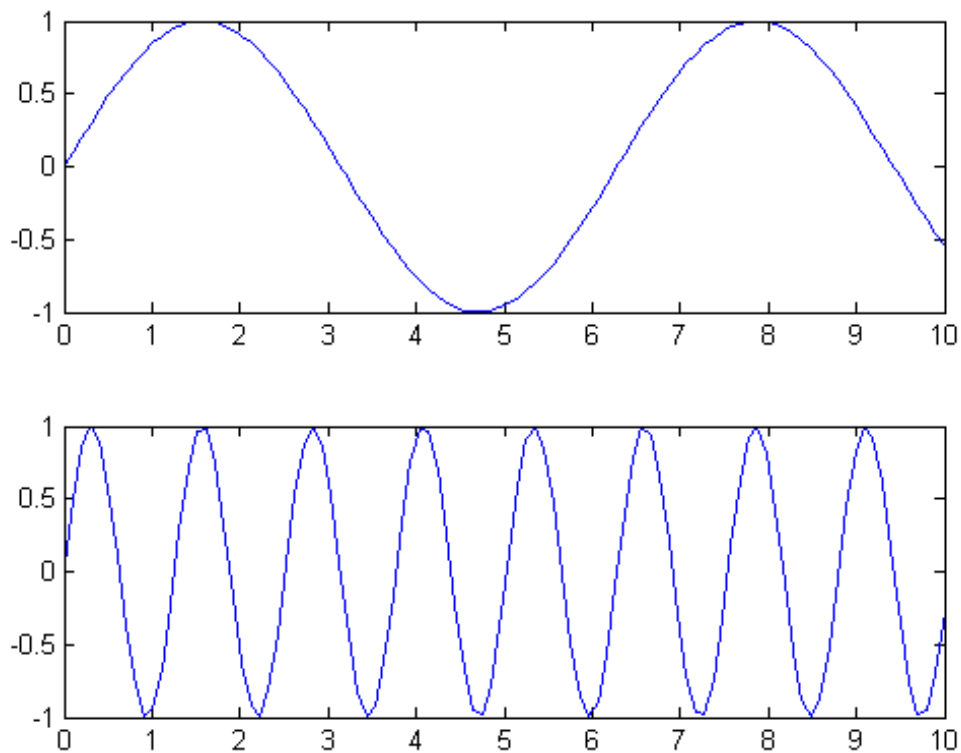

### Quadrant of Subplots

Create a figure divided into four subplots.

Define the data.

```
x = linspace(0,10);
y1 = sin(x);
y2 = sin(2*x);
y3 = sin(4*x);
```

# subplot

---

```
y4 = sin(8*x);
```

Plot the four sine waves and title each subplot.

```
figure
subplot(2,2,1);
plot(x,y1);
title('Subplot 1: sin(x)')

subplot(2,2,2);
plot(x,y2);
title('Subplot 2: sin(2x)')

subplot(2,2,3)
plot(x,y3);
title('Subplot 3: sin(4x)')

subplot(2,2,4)
plot(x,y4);
title('Subplot 4: sin(8x)')
```

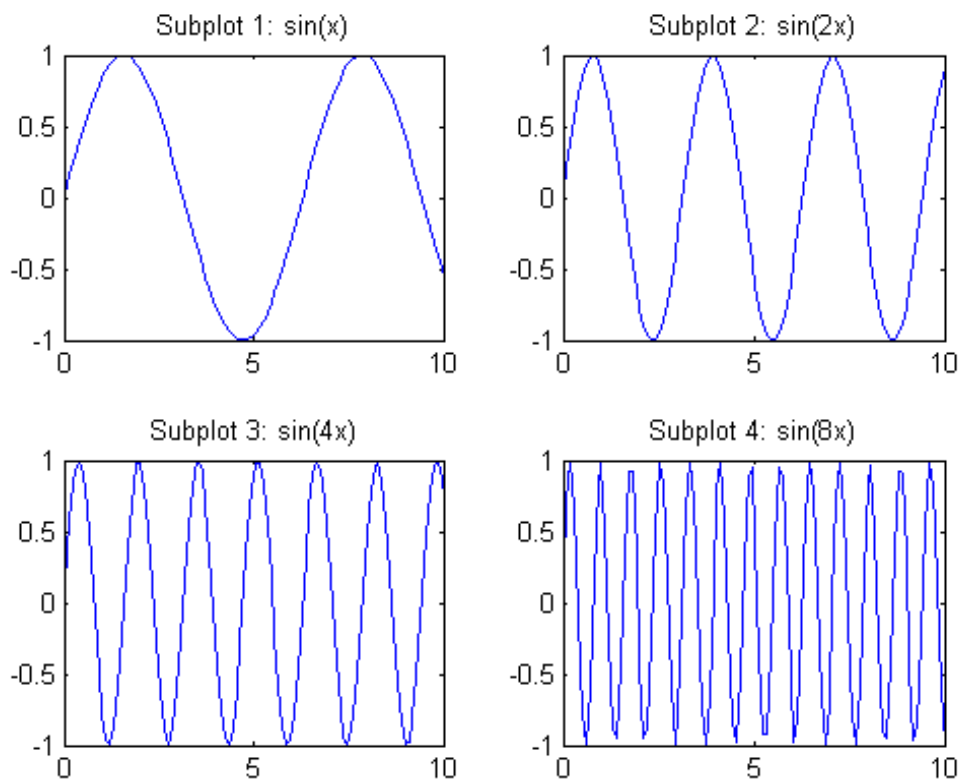

### Subplots with Different Sizes

Create a figure containing subplots with different sizes.

Define a vector of sine values and a vector of polynomial values.

```
x = linspace(-3.8,3.8);
y_cos = cos(x);
y_poly = 1 - x.^2./2 + x.^4./24;
```

# subplot

---

Plot the sine wave in the first subplot and the polynomial in the second subplot. Create a third subplot that spans the lower half of the figure and plot both vectors together. Add titles to each subplot.

```
figure
subplot(2,2,1);
plot(x,y_cos);
title('Subplot 1: Cosine')

subplot(2,2,2);
plot(x,y_poly,'g');
title('Subplot 2: Polynomial')

subplot(2,2,[3,4]);
plot(x,y_cos,'b',x,y_poly,'g');
title('Subplot 3 and 4: Both')
```

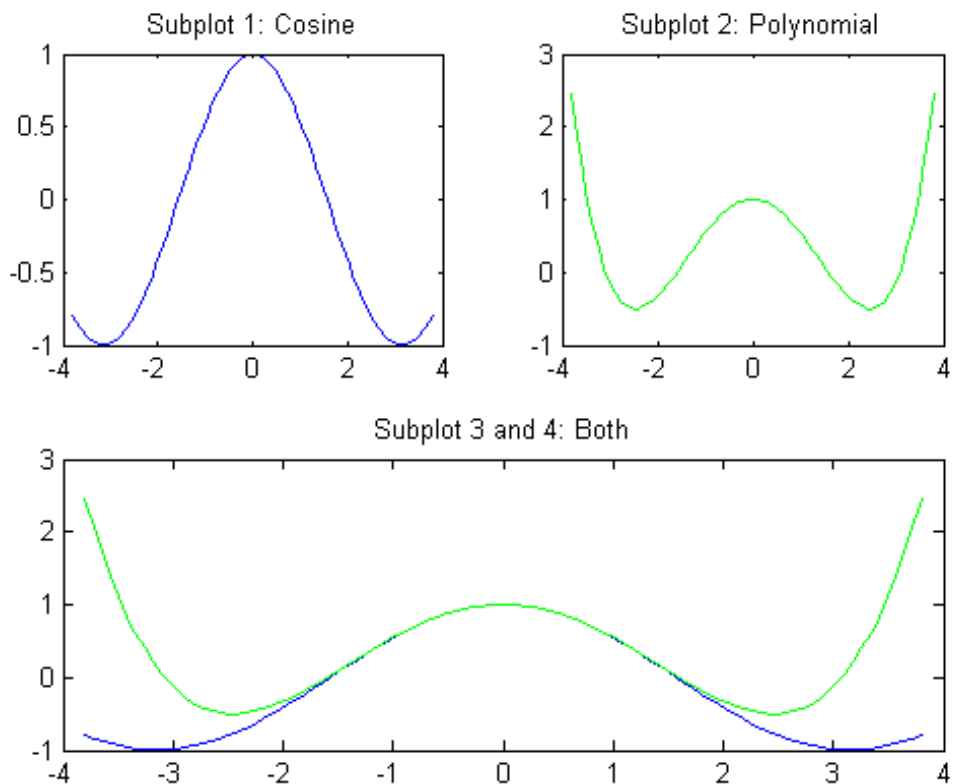

### Replacing Subplots

Replace an existing subplot with an empty axes.

Initialize the random number generator. Use a loop to create a figure with four stem plots of random data.

```
rng(0, 'twister');
figure
for k = 1:4
```

# subplot

```
data = rand(1,10);
subplot(2, 2, k)
stem(data);
end
```

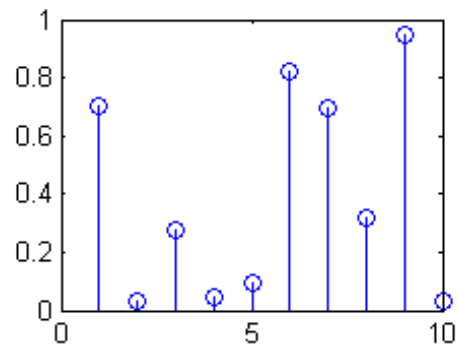
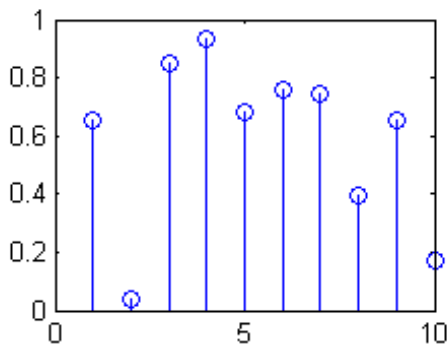
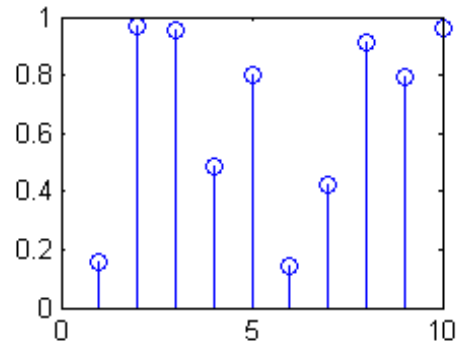
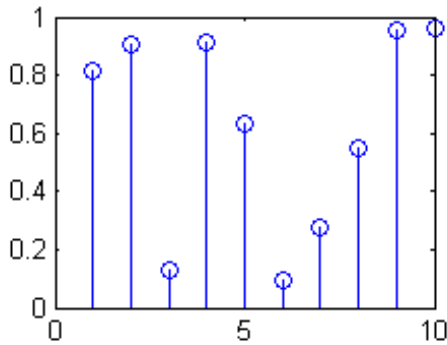

Replace the second subplot with an empty axes.

```
subplot(2,2,2, 'replace')
```



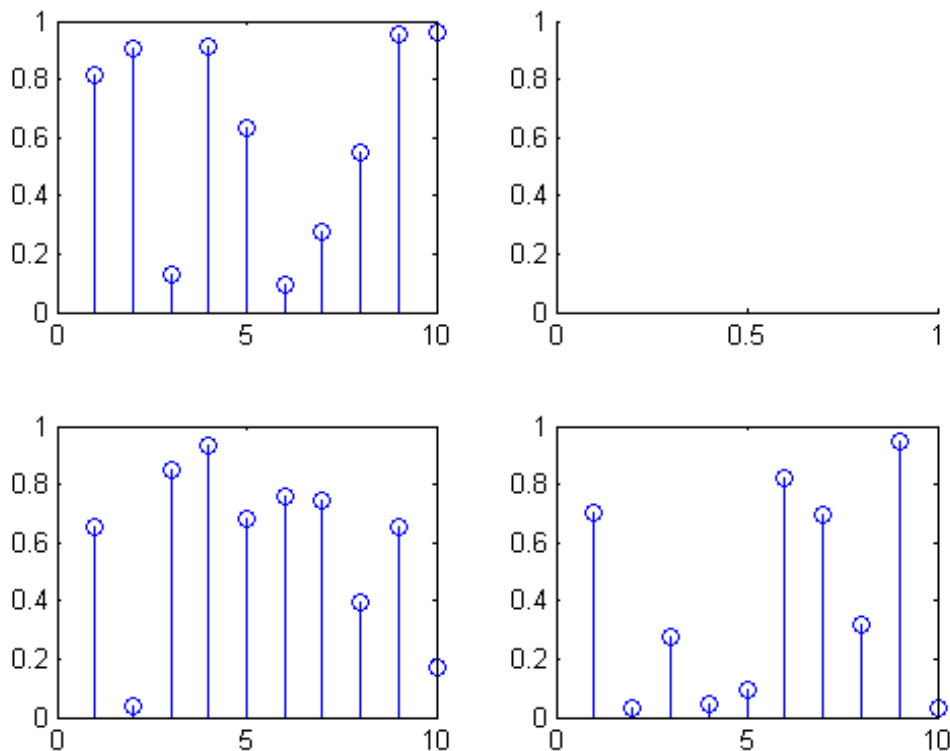

### Subplots at Specified Positions

Create a figure with two subplots that are not aligned.

Define  $y$  as data from the magic function.

```
y = magic(4);
```

Plot  $y$  in one subplot. Create a bar graph of  $y$  in a second subplot. Specify a custom position for each subplot.

# subplot

```
figure
positionVector1 = [0.1, 0.2, 0.3, 0.3];
subplot('Position',positionVector1)
plot(y)

positionVector2 = [0.5, 0.1, 0.4, 0.7];
subplot('Position',positionVector2)
bar(y)
```

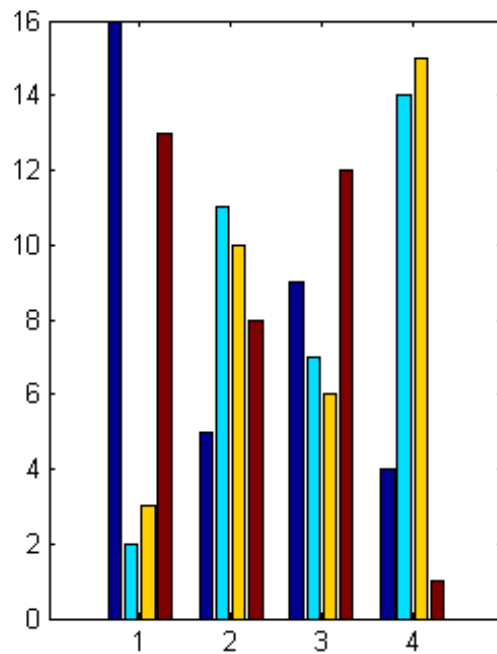
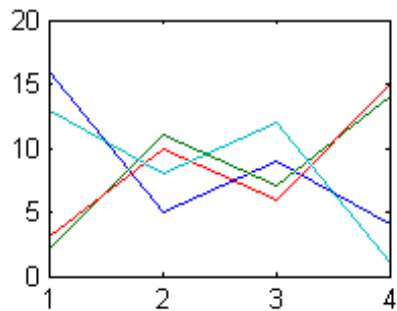

## Return Subplot Axes Handle

Create a figure with two subplots and return the subplot axes handles, h1 and h2.

```
figure
h1 = subplot(2,1,1);
h2 = subplot(2,1,2);
```

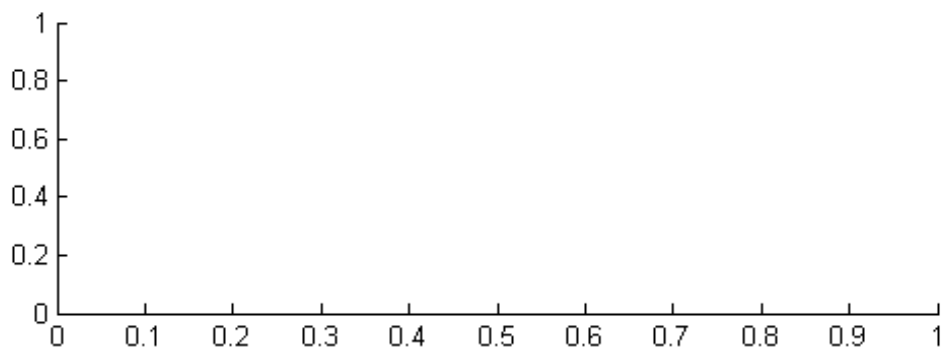
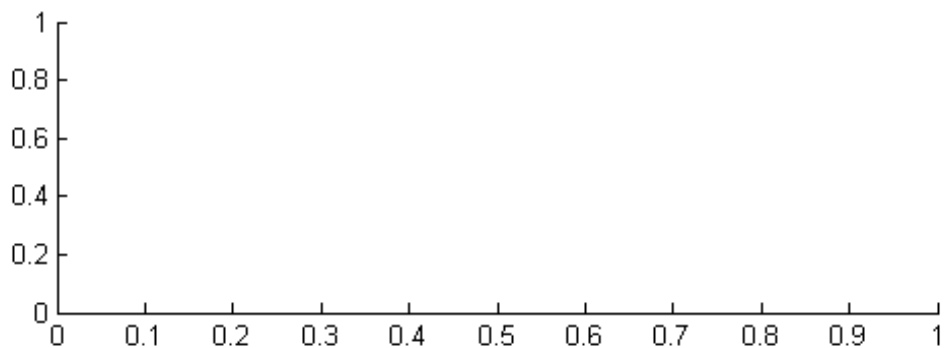

# subplot

---

Store the data from the `peaks` function in matrix `Z`. Plot the first 20 rows of `Z` in the upper subplot by referring to its handle, `h1`. Plot the entire data set in the lower subplot.

```
Z = peaks;
plot(h1,Z(1:20,:))
plot(h2,Z);
```

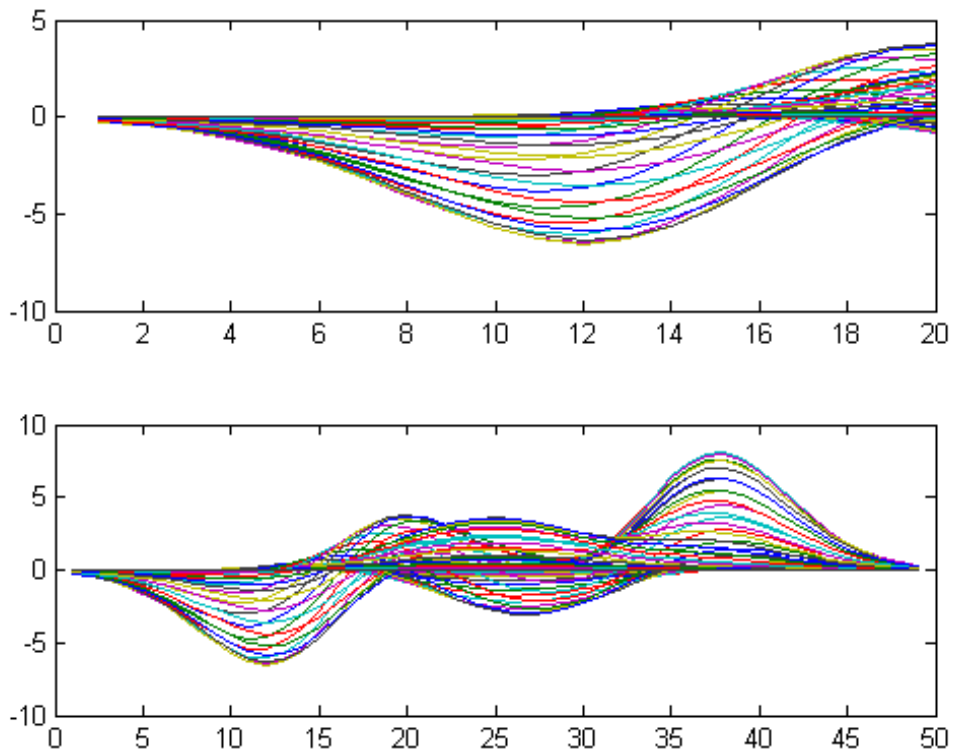

Change the tick marks for the lower subplot using axes properties. Execute plotting functions before specifying axes properties to avoid overriding existing axes property settings.

```
set(h2, 'XTick', [0,10,25,40,50])
```

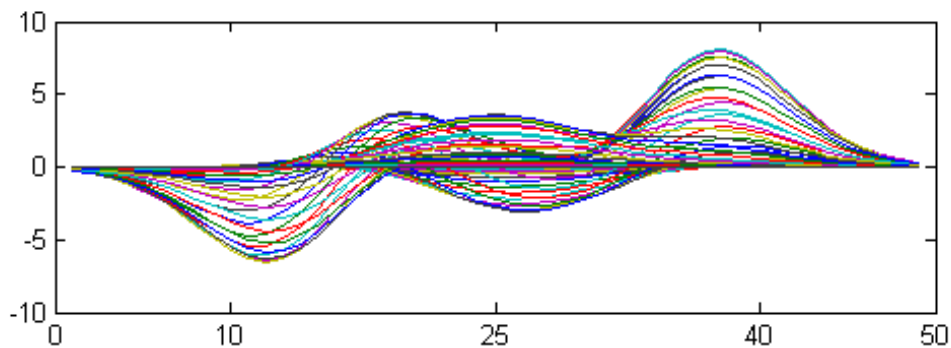
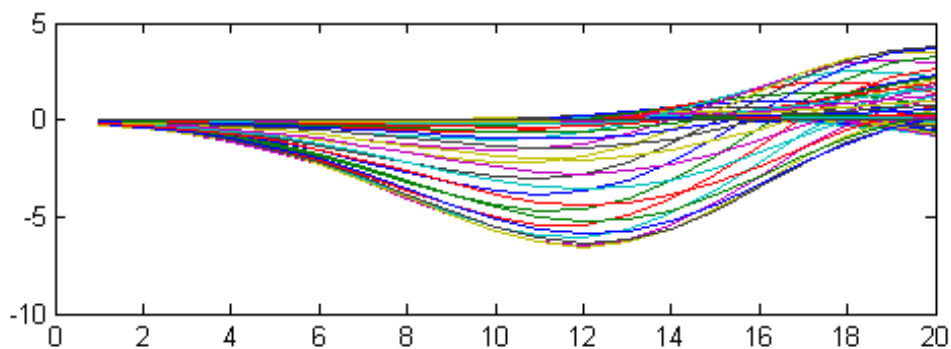

### **Make Axes the Current Axes**

Make a subplot the current axes using its axes handle.

# subplot

---

Create a figure with multiple subplots. Store the subplot axes handles in vector `h`.

```
figure;
for k = 1:4
 h(k) = subplot(2,2,k);
end
```

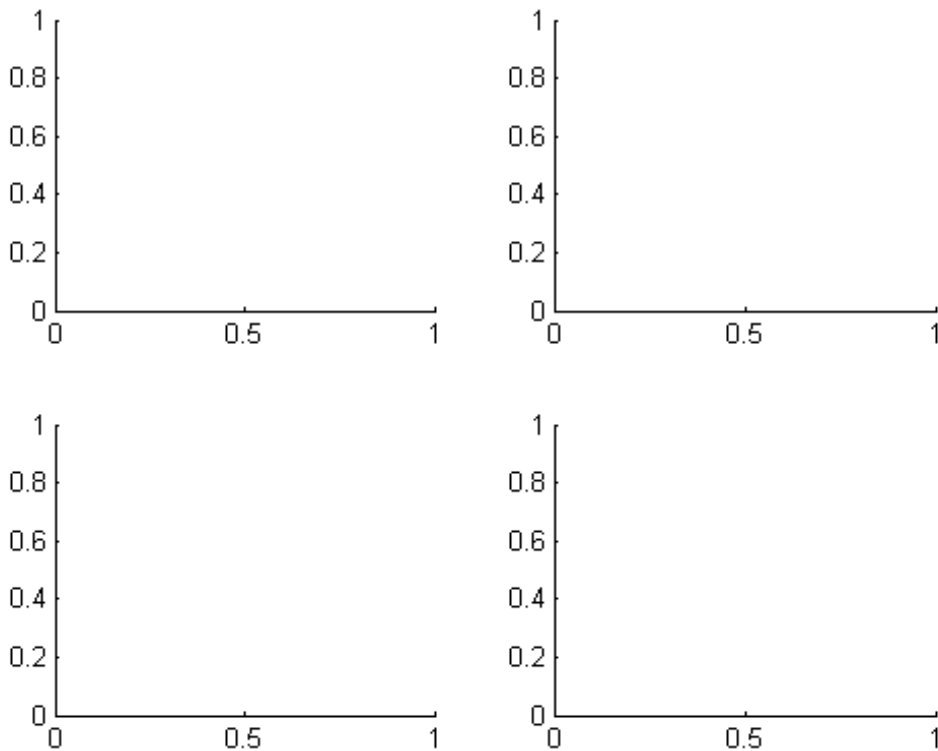

Make the second subplot the current axes. Plot a sine wave and change the axis limits.

```
x = linspace(1,50);
y = sin(x);

subplot(h(2));
plot(x,y,'Color',[0.1, 0.5, 0.1]);
title('Second Subplot')
axis([0,50,-1,1])
```

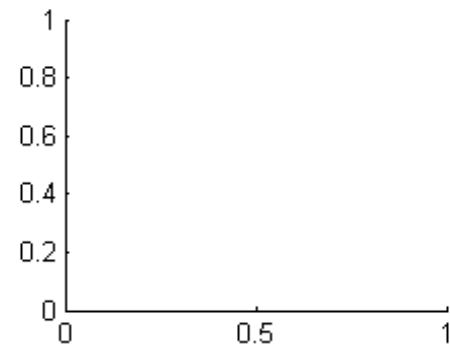
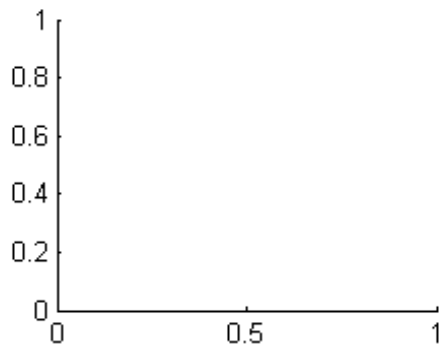
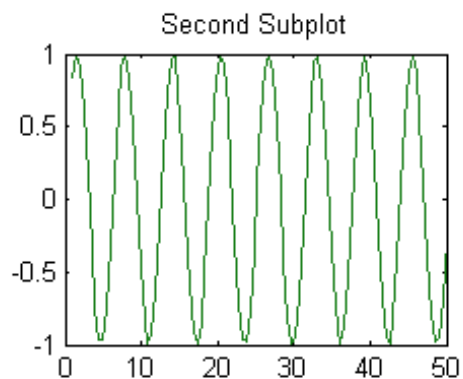
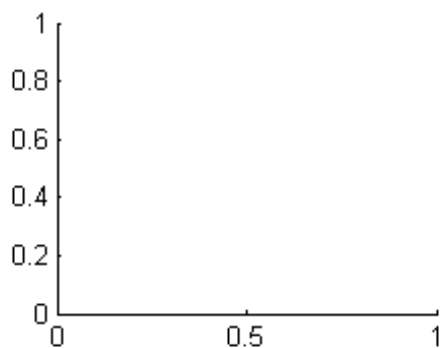

# subplot

---

## Tips

- If the axes already exists, then the command `subplot(m,n,p)` makes the subplot in position `p` the current axes.
- `subplot(111)` is an exception and not identical in behavior to `subplot(1,1,1)`. For reasons of backwards compatibility, `subplot(111)` is a special case of `subplot` that does not immediately create an axes, but sets up the figure so that the next graphics command executes `clf reset`. The next graphics command deletes all the figure children and creates a new axes in the default position. `subplot(111)` does not return a handle and an error occurs if code specifies a return argument.
- If a new subplot axes overlaps an existing axes, then MATLAB deletes the existing axes. To overlay a new axes on top of existing subplots, use the `axes` command. For example, `subplot('Position',[.35 .35 .3 .3])` deletes any underlying subplots, but `axes('Position',[.35 .35 .3 .3])` positions a new axes in the middle of the figure without deleting any underlying axes.
- When using a script to create subplots, MATLAB does not finalize the `Position` property value until either a `drawnow` command is issued or MATLAB returns to await a user command. The `Position` property value for a subplot is subject to change until the script either refreshes the plot or exits.

## See Also

`axes` | `cla` | `clf` | `figure` | `gca`



<b>Purpose</b>	Subscripted assignment
<b>Syntax</b>	<code>A = subsasgn(A, S, B)</code>
<b>Description</b>	<p><code>A = subsasgn(A, S, B)</code> is called by MATLAB for the syntax <code>A(i) = B</code>, <code>A{i} = B</code>, or <code>A.i = B</code> when <code>A</code> is an object.</p> <p>MATLAB uses the built-in <code>subsasgn</code> function to interpret indexed assignment statements. Modify the indexed assignment behavior of classes by overloading <code>subsasgn</code> in the class.</p> <p>If <code>A</code> is a fundamental class (see “Fundamental MATLAB Classes”), then an indexed reference to <code>A</code> calls the built-in <code>subsasgn</code> function. It does not call a <code>subsasgn</code> method that you have overloaded for that class. Therefore, if <code>A</code> is an array of class <code>double</code>, and there is an <code>@double/subsasgn</code> method on your MATLAB path, the statement <code>A(I) = B</code> calls the MATLAB built-in <code>subsasgn</code> function.</p>
<b>Tips</b>	<p>Within a class’s own methods, MATLAB calls the built-in <code>subsasgn</code>, not the class defined <code>subsasgn</code>. This behavior enables to use the default <code>subsasgn</code> behavior when defining specialized indexing for your class. See “<code>subsref</code> and <code>subsasgn</code> Within Class Methods — Built-In Called” for more information.</p>
<b>Input Arguments</b>	<p><b>A</b> Object</p> <p><b>S</b> struct array with two fields, <code>type</code> and <code>subs</code>.</p> <ul style="list-style-type: none"> <li>• <code>type</code> is a string containing '()', '{}', or '.', where '()' specifies integer subscripts, '{}' specifies cell array subscripts, and '.' specifies subscripted structure fields.</li> <li>• <code>subs</code> is a cell array or string containing the actual subscripts.</li> </ul> <p><b>B</b></p>

# subsasgn

---

Assignment value (right-hand side)

## Output Arguments

**A**  
Result of evaluating assignment.

## Examples

See how MATLAB calls `subsasgn` for the expression:

```
A(1:2,:) = B;
```

The syntax `A(1:2,:) = B` calls `A = subsasgn(A,S,B)` where `S` is a 1-by-1 structure with `S.type = '()'` and `S.subs = {1:2, ':'}`. The string `':'` indicates a colon used as a subscript.

---

See how MATLAB calls `subsasgn` for the expression:

```
A{1:2} = B;
```

The syntax `A{1:2} = B` calls `A = subsasgn(A,S,B)` where `S.type = '{}'` and `S.subs = {[1 2]}`.

---

See how MATLAB calls `subsasgn` for the expression:

```
A.field = B;
```

The syntax `A.field = B` calls `A = subsasgn(A,S,B)` where `S.type = '.'` and `S.subs = 'field'`.

---

See how MATLAB calls `subsasgn` for the expression:

```
A(1,2).name(3:5)=B;
```

Simple calls combine in a straightforward way for more complicated indexing expressions. In such cases, `length(S)` is the number of subscripting levels. For instance, `A(1,2).name(3:5)=B` calls `A=subsasgn(A,S,B)` where `S` is a 3-by-1 structure array with the following values:

```
S(1).type = '()' S(2).type = '.' S(3).type = '()'
S(1).subs = {1,2} S(2).subs = 'name' S(3).subs = {[3 4
 5]}
```

## Algorithms

In the assignment  $A(J,K,\dots) = B(M,N,\dots)$ , subscripts  $J, K, M, N$ , and so on, can be scalar, vector, or arrays, when all the following are true:

- The number of subscripts specified for  $B$ , excluding trailing subscripts equal to 1, does not exceed the value returned by `ndims(B)`.
- The number of nonscalar subscripts specified for  $A$  equals the number of nonscalar subscripts specified for  $B$ . For example,  $A(5, 1:4, 1, 2) = B(5:8)$  is valid because both sides of the equation use one nonscalar subscript.
- The order and length of all nonscalar subscripts specified for  $A$  matches the order and length of nonscalar subscripts specified for  $B$ . For example,  $A(1:4, 3, 3:9) = B(5:8, 1:7)$  is valid because both sides of the equation (ignoring the one scalar subscript 3) use a 4-element subscript followed by a 7-element subscript.

See `numel` for information concerning the use of `numel` with regards to the overloaded `subsasgn` function.

## See Also

`subsref` | `substruct`

## Tutorials

- “Indexed Reference and Assignment”

# subsindex

---

**Purpose**                 Subscript indexing with object

**Syntax**                 `ind = subsindex(A)`

**Description**           `ind = subsindex(A)` called by MATLAB for the expression `X(A)` when `A` is an object, unless such an expression results in a call to an overloaded `subsref` or `subsasgn` method for `X`. `subsindex` must return the value of the object as a zero-based integer index. (`ind` must contain integer values in the range 0 to `prod(size(X))-1`.) Call `subsindex` directly from an overloaded `subsref` or `subsasgn` method.

MATLAB invokes `subsindex` separately on all the subscripts in an expression, such as `X(A,B)`.

**See Also**                 `subsasgn` | `subsasgn`

**Tutorials**

- “Using Objects as Indices”

<b>Purpose</b>	Angle between two subspaces
<b>Syntax</b>	<code>theta = subspace(A,B)</code>
<b>Description</b>	<code>theta = subspace(A,B)</code> finds the angle between two subspaces specified by the columns of A and B. If A and B are column vectors of unit length, this is the same as <code>acos(abs(A'*B))</code> .
<b>Tips</b>	If the angle between the two subspaces is small, the two spaces are nearly linearly dependent. In a physical experiment described by some observations A, and a second realization of the experiment described by B, <code>subspace(A,B)</code> gives a measure of the amount of new information afforded by the second experiment not associated with statistical errors of fluctuations.
<b>Examples</b>	<p>Consider two subspaces of a Hadamard matrix, whose columns are orthogonal.</p> <pre>H = hadamard(8); A = H(:,2:4); B = H(:,5:8);</pre> <p>Note that matrices A and B are different sizes — A has three columns and B four. It is not necessary that two subspaces be the same size in order to find the angle between them. Geometrically, this is the angle between two hyperplanes embedded in a higher dimensional space.</p> <pre>theta = subspace(A,B) theta =     1.5708</pre> <p>That A and B are orthogonal is shown by the fact that theta is equal to <math>\pi/2</math>.</p> <pre>theta - pi/2 ans =     0</pre>

# subsref

---

**Purpose** Redefine subscripted reference for objects

**Syntax** `B = subsref(A,S)`

**Description** `B = subsref(A,S)` is called by MATLAB for the syntax `A(i)`, `A{i}`, or `A.i` when `A` is an object. `S` is a struct array with two fields, `type` and `subs`.

The `type` field is string containing `'()'`, `'{}'`, or `','`, where `'()'` specifies integer subscripts, `'{}'` specifies cell array subscripts, and `','` specifies subscripted structure fields. The `subs` field is a cell array or a string containing the actual subscripts.

`B` is the result of the indexed expression.

MATLAB uses the built-in `subsref` function to interpret indexed references to objects. To modify the indexed reference behavior of objects, overload `subsref` in the class.

If `A` is a fundamental class (see “Fundamental MATLAB Classes”), then an indexed reference to `A` calls the built-in `subsref` function. It does not call a `subsref` method that you have overloaded for that class. Therefore, if `A` is an array of class `double`, and there is an `@double/subsref` method on your MATLAB path, the statement `A(I)` calls the MATLAB built-in `subsref` function.

**Tips** Within a class’s own methods, MATLAB calls the built-in `subsref`, not the class defined `subsref`. This behavior enables to use the default `subsref` behavior when defining specialized indexing for your class. See “`subsref` and `subsasgn` Within Class Methods — Built-In Called” for more information.

**Examples** See how MATLAB calls `subsref` for the expression:

```
A(1:2,:)
```

The syntax `A(1:2,:)` calls `B = subsref(A,S)` where `S` is a 1-by-1 structure with `S.type='()'` and `S.subs={1:2,','}`. The string `','` indicates a colon used as a subscript.

See how MATLAB calls `subsref` for the expression:

```
A{1:2}
```

The syntax `A{1:2}` calls `B = subsref(A,S)` where `S.type='{}'` and `S.subs={1 2}`.

See how MATLAB calls `subsref` for the expression:

```
A.field
```

The syntax `A.field` calls `B = subsref(A,S)` where `S.type='.'` and `S.subs='field'`.

See how MATLAB calls `subsref` for the expression:

```
A(1,2).name(3:5)
```

Simple calls combine in a straightforward way for more complicated indexing expressions. In such cases, `length(S)` is the number of subscript levels. For instance, `A(1,2).name(3:5)` calls `subsref(A,S)` where `S` is a 3-by-1 structure array with the following values:

<code>S(1).type='()'</code>	<code>S(2).type='.'</code>	<code>S(3).type='()'</code>
<code>S(1).subs={1,2}</code>	<code>S(2).subs='name'</code>	<code>S(3).subs={[3 4 5]}</code>

## See Also

`numel` | `subsasgn` | `substruct`

## Tutorials

- “Indexed Reference and Assignment”

# substruct

---

**Purpose** Create structure argument for subsasgn or subsref

**Syntax** `S = substruct(type1, subs1, type2, subs2, ...)`

**Description** `S = substruct(type1, subs1, type2, subs2, ...)` creates a structure with the fields required by an overloaded `subsref` or `subsasgn` method. Each `type` string must be one of `'.'`, `'()'` , or `'{'`. The corresponding `subs` argument must be either a field name (for the `'.'` type) or a cell array containing the index vectors (for the `'()'`  or `'{'` types).

**Output Arguments** **S**  
struct with these fields:

- `type`: one of `'.'`, `'()'` , or `'{'`
- `subs`: subscript values (field name or cell array of index vectors)

**Examples** Call `subsref` with arguments equivalent to the syntax:

```
B = A(3,5).field;
```

where `A` is an object of a class that implements a `subsref` method

Use `substruct` to form the input struct, `S`:

```
S = substruct('()', {3,5}, '.', 'field');
```

Call the class method:

```
B = subsref(A,S);
```

The struct created by `substruct` in this example contains:

```
S(1)
```

```
ans =
```



```
type: '()'
subs: {[3] [5]}
```

S(2)

ans =

```
type: '.'
subs: 'field'
```

**See Also**

subsasgn | subsref

**Tutorials**

- “Indexed Reference and Assignment”

# subvolume

---

**Purpose** Extract subset of volume data set

**Syntax**  
`[Nx,Ny,Nz,Nv] = subvolume(X,Y,Z,V,limits)`  
`[Nx,Ny,Nz,Nv] = subvolume(V,limits)`  
`Nv = subvolume(...)`

**Description** `[Nx,Ny,Nz,Nv] = subvolume(X,Y,Z,V,limits)` extracts a subset of the volume data set `V` using the specified axis-aligned `limits`. `limits = [xmin,xmax,ymin, ymax,zmin,zmax]` (Any NaNs in the limits indicate that the volume should not be cropped along that axis.)

The arrays `X`, `Y`, and `Z` define the coordinates for the volume `V`. The subvolume is returned in `NV` and the coordinates of the subvolume are given in `NX`, `NY`, and `NZ`.

`[Nx,Ny,Nz,Nv] = subvolume(V,limits)` assumes the arrays `X`, `Y`, and `Z` are defined as

```
[X,Y,Z] = meshgrid(1:N,1:M,1:P)
```

where `[M,N,P] = size(V)`.

`Nv = subvolume(...)` returns only the subvolume.

## Examples

This example uses a data set that is a collection of MRI slices of a human skull. The data is processed in a variety of ways:

- The 4-D array is squeezed (`squeeze`) into three dimensions and then a subset of the data is extracted (`subvolume`).
- The outline of the skull is an isosurface generated as a patch (`p1`) whose vertex normals are recalculated to improve the appearance when lighting is applied (`patch`, `isosurface`, `isonormals`).
- A second patch (`p2`) with interpolated face color draws the end caps (`FaceColor`, `isocaps`).
- The view of the object is set (`view`, `axis`, `daspect`).
- A 100-element grayscale colormap provides coloring for the end caps (`colormap`).

- Adding lights to the right and left of the camera illuminates the object (camlight, lighting).

```
load mri
D = squeeze(D);
[x,y,z,D] = subvolume(D,[60,80,nan,80,nan,nan]);
p1 = patch(isosurface(x,y,z,D, 5),...
 'FaceColor','red','EdgeColor','none');
isonormals(x,y,z,D,p1);
p2 = patch(isocaps(x,y,z,D, 5),...
 'FaceColor','interp','EdgeColor','none');
view(3); axis tight; daspect([1,1,.4])
colormap(gray(100))
camlight right; camlight left; lighting gouraud
```

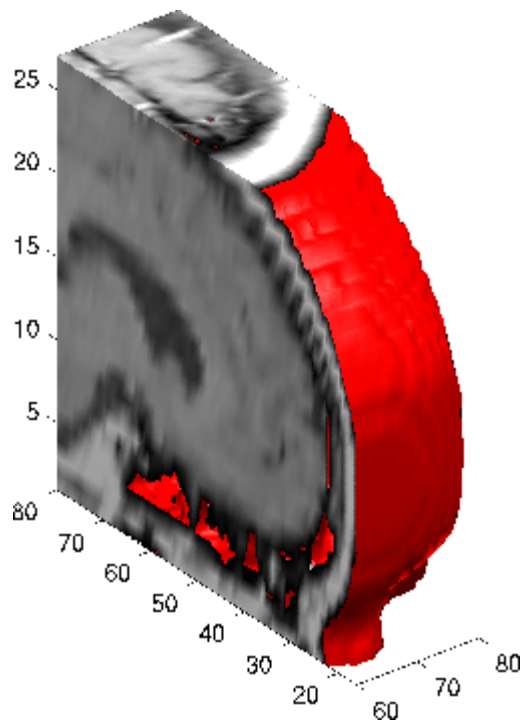

# subvolume

---

## **See Also**

isocaps | isonormals | isosurface | reducepatch | reducevolume  
| smooth3

---

<b>Purpose</b>	Sum of array elements
<b>Syntax</b>	<pre>S = sum(A) S = sum(A,dim) S = sum( __ , type)</pre>
<b>Description</b>	<p><code>S = sum(A)</code> returns the sum of the elements of <code>A</code> along the first array dimension whose size does not equal 1:</p> <ul style="list-style-type: none"><li>• If <code>A</code> is a vector, then <code>sum(A)</code> returns the sum of the elements.</li><li>• If <code>A</code> is a nonempty, nonvector matrix, then <code>sum(A)</code> treats the columns of <code>A</code> as vectors and returns a row vector whose elements are the sums of each column.</li><li>• If <code>A</code> is an empty 0-by-0 matrix, then <code>sum(A)</code> returns 0, a 1-by-1 matrix.</li><li>• If <code>A</code> is a multidimensional array, then <code>sum(A)</code> treats the values along the first array dimension whose size does not equal 1 as vectors and returns an array of row vectors. The size of this dimension becomes 1 while the sizes of all other dimensions remain the same.</li></ul> <p><code>S = sum(A,dim)</code> sums the elements of <code>A</code> along dimension <code>dim</code>. The <code>dim</code> input is a positive integer scalar.</p> <p><code>S = sum( __ , type)</code> accumulates in and returns an array in the class specified by <code>type</code>, using any of the input arguments in the previous syntaxes. <code>type</code> can be 'double' or 'native'.</p>
<b>Input Arguments</b>	<p><b>A - Input array</b> scalar   vector   matrix   multidimensional array</p> <p>Input array, specified as a scalar, vector, matrix, or multidimensional array.</p> <p><b>Data Types</b> single   double   int8   int16   int32   int64   uint8   uint16   uint32   uint64   logical   char</p>

**Complex Number Support:** Yes

**dim - Dimension to operate along**

positive integer scalar

Dimension to operate along, specified as a positive integer scalar. If no value is specified, the default is the first array dimension whose size does not equal 1.

Consider a two-dimensional input array, A:

- `sum(A, 1)` works on successive elements in the columns of A and returns a row vector of the sums of each column.
- `sum(A, 2)` works on successive elements in the rows of A and returns a column vector of the sums of each row.

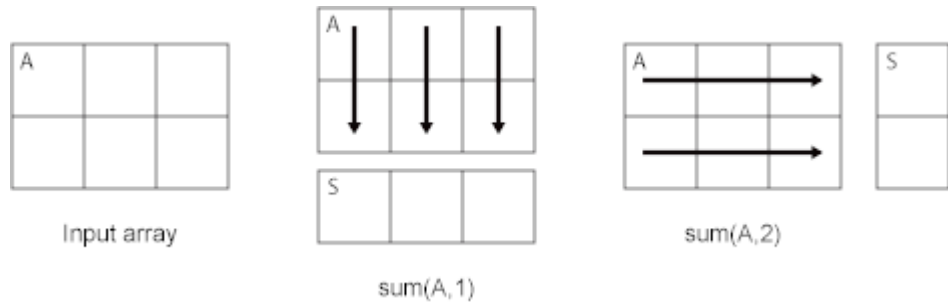

`sum` returns A if `dim` is greater than `ndims(A)`.

**Data Types**

double | single | int8 | int16 | int32 | int64 | uint8 |  
uint16 | uint32 | uint64

**type - Output class**

'double' | 'native'

Output class, specified as 'double' or 'native', defines the data type that the operation is performed in and returned in.

- If `type` is 'double', then `sum` computes and returns a double-precision array, regardless of the input data type. For example, if A is single,

then `sum` accumulates in and returns in `double`. This is the default behavior for integer data types when `type` is not specified.

- If `type` is `'native'`, `sum` accumulates natively and returns an array with the same data type as the input array `A`. For example, if `A` has data type `int8`, then `sum(A, 'native')` accumulates in and returns in `int8`. This is the default behavior for `single` and `double` data types when `type` is not specified.

### Data Types

`char`

## Output Arguments

### S - Sum array

`scalar` | `vector` | `matrix` | `multidimensional array`

Sum array, returned as a scalar, vector, matrix, or multidimensional array. The dimension of `A` acted on by `sum` has size 1 in `S`.

The class of `S` is as follows:

- If the `type` argument is not used and the input is not `single`, then the output is `double`.
- If the `type` argument is not used and the input is `single`, then the output is `single`.
- If the `type` argument specifies `'double'`, then the output is `double` regardless of the input data type.
- If the `type` argument specifies `'native'`, then the output is the same data type as the input.

## Examples

### Sum of Vector Elements

Create a vector and compute the sum of the elements.

```
A = 1:10;
S = sum(A)
```

```
S =
```

55

## Sum of Elements in Each Column

Create a 3-by-3 matrix.

A = [1 3 2; 4 2 5; 6 1 4]

A =

1	3	2
4	2	5
6	1	4

Compute the sum of the elements in each column.

S = sum(A)

S =

11	6	11
----	---	----

## Sum of Elements in Each Row

Create a 3-by-3 matrix.

A = [1 3 2; 4 2 5; 6 1 4]

A =

1	3	2
4	2	5
6	1	4

Compute the sum of the elements in each row.

S = sum(A,2)

S =



---

```
6
11
11
```

### Sum of Elements in Each Plane

Create a 4-by-2-by-3 multidimensional array of ones.

```
A = ones(4,2,3)
```

```
A(:,:,1) =
```

```
1 1
1 1
1 1
1 1
```

```
A(:,:,2) =
```

```
1 1
1 1
1 1
1 1
```

```
A(:,:,3) =
```

```
1 1
1 1
1 1
1 1
```

Compute the sum along the third (`dim = 3`) dimension.

```
S = sum(A,3)
```

```
S =
```

## sum

---

```
3 3
3 3
3 3
3 3
```

The length of the first dimension matches `size(A,1)`, the length of the second dimension matches `size(A,2)`, and the length of the third dimension is 1.

### Integer Overflow Due to Output Data Type

Create a vector of signed 8-bit integers and compute the sum of the elements.

```
A = int8(1:20);
S = sum(A)
```

```
S =
```

```
210
```

The output has data type `double` because of default behavior.

```
class(S)
```

```
ans =
```

```
double
```

To keep the same data type in the output as in the input, specify `type` as `'native'`.

```
S = sum(A, 'native')
```

```
S =
```

```
127
```

---

This disagrees with the double-precision value of 210 because the output has data type `int8` and is saturated.

```
class(S)
```

```
ans =
```

```
int8
```

**See Also**

`cumsum` | `diff` | `isfloat` | `prod`

# summary

---

**Purpose** Print summary of table or categorical array

**Syntax** `summary(T)`

`summary(A)`  
`summary(A,dim)`

**Description** `summary(T)` prints a summary of the table, `T`. The table summary displays the table description from `T.Properties.Description` followed by a summary of the table variables.

`summary(A)` prints a summary of the categorical array, `A`.

- If `A` is a vector, then `summary(A)` displays the category names along with the number of elements in each category (the category counts). Furthermore, the summary contains the number of elements that are undefined.
- If `A` is a matrix, then `summary` treats the columns of `A` as vectors and displays the category counts for each column of `A`.
- If `A` is a multidimensional array, then `summary` acts along the first array dimension whose size does not equal 1.

`summary(A,dim)` prints the category counts of the categorical array, `A`, along dimension `dim`.

For example, you can display the counts of each row in a categorical array using `counts(A,2)`.

## Input Arguments

### **T - Input table**

table

Input table, specified as a table.

### **A - Categorical array**

vector | matrix | multidimensional array

Categorical array, specified as a vector, matrix, or multidimensional array.

**dim - Dimension of A to operate along**

positive integer scalar

Dimension of A to operate to along, specified as a positive integer scalar. If no value is specified, the default is the first array dimension whose size does not equal 1.

Consider a two-dimensional categorical array, A:

If  $\text{dim} = 1$ , then  $\text{summary}(A, 1)$  displays the category counts for each column of A.

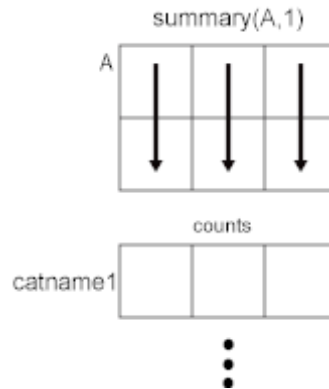

If  $\text{dim} = 2$ , then  $\text{summary}(A, 2)$  returns the category counts of each row of A.

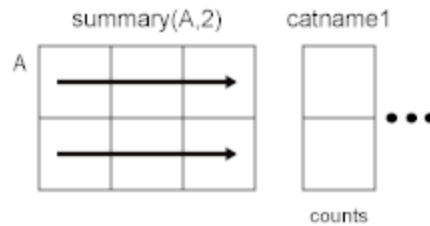

# summary

---

If `dim` is greater than `ndims(A)`, then `summary(A)` returns an array the same size as `A` for each category. `summary` returns 1 for elements in the corresponding category and 0 otherwise.

## Examples

### Summary of Table

Create a table.

```
load patients
BloodPressure = [Systolic Diastolic];
T = table(Gender, Age, Smoker, BloodPressure, 'RowNames', LastName);
```

Add descriptions and units to table T.

```
T.Properties.Description = 'Simulated patient data';
T.Properties.VariableUnits = {'' 'Yrs' '' 'mm Hg'};
T.Properties.VariableDescriptions{4} = 'Systolic/Diastolic';
```

Print a summary of table T.

```
format compact
```

```
summary(T)
```

```
Description: Simulated patient data
Variables:
 Gender: 100x1 cell string
 Age: 100x1 double
 Units: Yrs
 Values:
 min 25
 median 39
 max 50
 Smoker: 100x1 logical
 Values:
 true 34
 false 66
 BloodPressure: 100x2 double
```

```

Units: mm Hg
Description: Systolic/Diastolic
Values:

```

	BloodPressure_1	BloodPressure_2
min	109	68
median	122	81.5
max	138	99

summary displays the minimum, median, and maximum values for each column of the variable BloodPressure.

### Summary of Categorical Vector

Create a 1-by-5 categorical vector.

```
A = categorical({'plane' 'car' 'train' 'car' 'plane'})
```

```
A =
```

```

 plane car train car plane

```

A has three categories, car, plane, and train.

Print a summary of A.

```
summary(A)
```

```

 car plane train
 2 2 1

```

car appears in two elements of A, plane appears in two elements, and train appears in one element.

Since A is a row vector, summary lists the occurrences of each category horizontally.

### Summary of Each Column in Categorical Array

Create a 3-by-2 categorical array, A, from a numeric array.

# summary

---

```
X = [1 3; 2 1; 3 1; 4 2];
valueset = 1:3;
catnames = {'red' 'green' 'blue'};

A = categorical(X,valueset,catnames)
```

```
A =

 red blue
 green red
 blue red
 <undefined> green
```

A has three categories, red, green, and blue. The value, 4, was not included in the valueset input to the categorical function. Therefore, the corresponding element, A(4,1), does not have a corresponding category and is undefined.

Print a summary of A.

```
summary(A)

 red 1 2
 green 1 1
 blue 1 1
 <undefined> 1 0
```

red appears in one element in the first column of A and two in the second column.

green appears in one element in the first column of A and none in the second column.

blue appears in one element in the first column of A and one in the second column.

A contains only one undefined element. It occurs in the first column.



**Category Counts of Each Row in Categorical Array**

Create a 3-by-2 categorical array, A, from a numeric array.

```
A = categorical([1 3; 2 1; 3 1],1:3,{'red' 'green' 'blue'})
```

A =

```

 red blue
 green red
 blue red

```

A has three categories, red, green, and blue.

Print a summary of A along the second dimension.

```
summary(A,2)
```

```

 red green blue
 1 0 1
 1 1 0
 1 0 1

```

red appears in one element in the first row of A, one in the second row, and one in the third row.

green appears in only one element. It occurs in the second row of A.

blue appears in one element in the first row of A and one in the third column.

**Definitions****Table Summary**

The table summary displays the table description from `T.Properties.Description` followed by information on the variables of T.

The summary contains the following information on the variables:

## summary

---

- Name: Size and Data Type — variable name from `T.Properties.VariableNames`, the size of the variable, and the data type of the variable.
- Units — variable's units from `T.Properties.VariableUnits`.
- Description — variable's description from `T.Properties.VariableDescriptions`.
- Values — only included for numeric variables, logical variables, or categorical variables.
  - numeric variables — minimum, median, and maximum values.
  - logical variables — number of values that are true and the number of values that are false.
  - categorical variables — number of elements from each category.

### See Also

`table` | `categorical` | `countcats` | `categories`

**Purpose**

Superclass names

**Syntax**

```
superclasses('ClassName')
superclasses(obj)
s = superclasses(...)
```

**Description**

`superclasses('ClassName')` displays the names of all visible superclasses of the MATLAB class with the name *ClassName*. Visible classes have a `Hidden` attribute value of `false` (the default).

`superclasses(obj)` `obj` is an instance of a MATLAB class. `obj` can be either a scalar object or an array of objects.

`s = superclasses(...)` returns the superclass names in a cell array of strings.

**Examples**

Get the name of the `hgsetget` class superclass:

```
superclasses('hgsetget')
```

Superclasses for class `hgsetget`:

```
handle
```

**See Also**

[properties](#) | [methods](#) | [events](#) | [classdef](#)

**Tutorials**

- “Hierarchies of Classes — Concepts”

# superiorto

---

**Purpose** Establish superior class relationship

**Syntax** `superiorto('class1', 'class2', ...)`

**Description** `superiorto('class1', 'class2', ...)` establishes that the class invoking this function in its constructor has higher precedence than the classes in the argument list.

The `superiorto` function establishes a precedence that determines which object method MATLAB calls. Use this function only from a constructor that calls the `class` function to create an object. For classes defined with `classdef` statements, see “Class Precedence”.

**Examples** Show function dispatching:

`a` is an object of class `class_a`, `b` is an object of class `class_b`, and `c` is an object of class `class_c`. The constructor method for `class_c` contains the statement `superiorto('class_a')`. Then, either of the following two statements:

```
e = fun(a,c);
e = fun(c,a);
```

invokes `class_c/fun`.

If you call a function with two objects having an unspecified relationship, MATLAB considers the two objects to have equal precedence. In this case, MATLAB calls the left-most object method. So `fun(b,c)` calls `class_b/fun`, while `fun(c,b)` calls `class_c/fun`.

**See Also** `inferiorto`

**Purpose** Open MathWorks Technical Support Web page

---

**Note** support will be removed in a future release.

---

**Syntax** support

**Description** support opens the MathWorks Technical Support Web page, <http://www.mathworks.com/support>, in a Web browser.

This Web page contains resources including

- A search engine, including an option for solutions to common problems
- Information about installation and licensing
- A patch archive for bug fixes you can download
- Other useful resources

**See Also** doc | web

# surf

---

## Purpose

3-D shaded surface plot

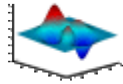

## Syntax

```
surf(Z)
surf(Z,C)
surf(X,Y,Z)
surf(X,Y,Z,C)
surf(...,'PropertyName',PropertyValue)
surf(axes_handles,...)
h = surf(...)
```

## Description

`surf(Z)` creates a three-dimensional shaded surface from the  $z$  components in matrix  $Z$ , using  $x = 1:n$  and  $y = 1:m$ , where  $[m,n] = \text{size}(Z)$ . The height,  $Z$ , is a single-valued function defined over a geometrically rectangular grid.  $Z$  specifies the color data, as well as surface height, so color is proportional to surface height.

`surf(Z,C)` plots the height of  $Z$ , a single-valued function defined over a geometrically rectangular grid, and uses matrix  $C$ , assumed to be the same size as  $Z$ , to color the surface. See [Coloring Mesh and Surface Plots](#) for information on defining  $C$ .

`surf(X,Y,Z)` uses  $Z$  for the color data and surface height.  $X$  and  $Y$  are vectors or matrices defining the  $x$  and  $y$  components of a surface. If  $X$  and  $Y$  are vectors,  $\text{length}(X) = n$  and  $\text{length}(Y) = m$ , where  $[m,n] = \text{size}(Z)$ . In this case, the vertices of the surface faces are  $(X(j), Y(i), Z(i,j))$  triples. To create  $X$  and  $Y$  matrices for arbitrary domains, use the `meshgrid` function.

`surf(X,Y,Z,C)` uses  $C$  to define color. MATLAB performs a linear transformation on this data to obtain colors from the current colormap.

`surf(...,'PropertyName',PropertyValue)` specifies surface Surfaceplot along with the data.

`surf(axes_handles,...)` plots into the axes with handle `axes_handle` instead of the current axes (`gca`).

`h = surf(...)` returns a handle to a Surfaceplot graphics object.

## Tips

`surf` does not accept complex inputs.

## Algorithms

Consider a parametric surface parameterized by two independent variables,  $i$  and  $j$ , which vary continuously over a rectangle; for example,  $1 \leq i \leq m$  and  $1 \leq j \leq n$ . The three functions  $x(i, j)$ ,  $y(i, j)$ , and  $z(i, j)$  specify the surface. When  $i$  and  $j$  are integer values, they define a rectangular grid with integer grid points. The functions  $x(i, j)$ ,  $y(i, j)$ , and  $z(i, j)$  become three  $m$ -by- $n$  matrices,  $X$ ,  $Y$ , and  $Z$ . Surface color is a fourth function,  $c(i, j)$ , denoted by matrix  $C$ .

Each point in the rectangular grid can be thought of as connected to its four nearest neighbors.

$$\begin{array}{c}
 i-1, j \\
 | \\
 i, j-1 - i, j - i, j+1 \\
 | \\
 i+1, j
 \end{array}$$

This underlying rectangular grid induces four-sided patches on the surface. To express this another way, `[X(:) Y(:) Z(:)]` returns a list of triples specifying points in 3-D space. Each interior point is connected to the four neighbors inherited from the matrix indexing. Points on the edge of the surface have three neighbors. The four points at the corners of the grid have only two neighbors. This defines a mesh of quadrilaterals or a *quad-mesh*.

You can specify surface color in two different ways: at the vertices or at the centers of each patch. In this general setting, the surface need not be a single-valued function of  $x$  and  $y$ . Moreover, the four-sided surface patches need not be planar. For example, you can have surfaces defined in polar, cylindrical, and spherical coordinate systems.

The shading function sets the shading. If the shading is `interp`, `C` must be the same size as `X`, `Y`, and `Z`; it specifies the colors at the vertices. The color within a surface patch is a bilinear function of the local coordinates. If the shading is `faceted` (the default) or `flat`, `C(i, j)` specifies the constant color in the surface patch:

$$\begin{array}{ccc} (i, j) & - & (i, j+1) \\ | & C(i, j) & | \\ (i+1, j) & - & (i+1, j+1) \end{array}$$

In this case, `C` can be the same size as `X`, `Y`, and `Z` and its last row and column are ignored. Alternatively, its row and column dimensions can be one less than those of `X`, `Y`, and `Z`.

The `surf` function specifies the viewpoint using `view(3)`.

The range of `X`, `Y`, and `Z` or the current setting of `XLimMode`, `YLimMode`, and `ZLimMode` axes properties determines the axis labels. You can also set these properties using `axis` function.

The range of `C` or the current setting of the `CLim` and `CLimMode` axes properties determines the color scaling. You can also set the properties using `caxis` function. The scaled color values are indices into the current colormap.

## Examples

### Surface Plot of Peaks Function

Use the `peaks` function to define `X`, `Y`, and `Z` as 25-by-25 matrices. Then, create a surface plot.

```
[X,Y,Z] = peaks(25);
```

```
figure
surf(X,Y,Z);
```



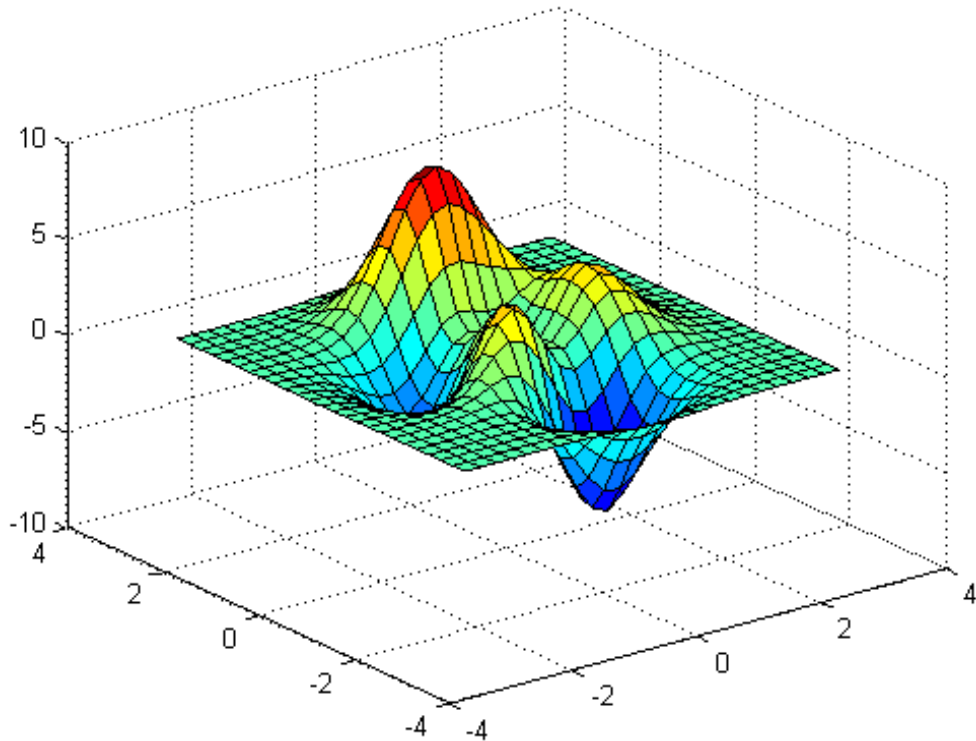

`surf` creates the surface plot from corresponding values in X, Y, and Z. If you do not define the color data C, then `surf` uses Z to determine the color, so color is proportional to surface height.

### **Sphere With Two Colors**

Create a sphere and color it using the pattern from a Hadamard matrix, which is a matrix that contains the values 1 and -1. Change the colors used in the plot by setting the colormap to an array of two RGB triplet values.

# surf

---

```
k = 5;
n = 2^k-1;
[x,y,z] = sphere(n);
c = hadamard(2^k);

figure
surf(x,y,z,c);
colormap([1 1 0; 0 1 1])
axis equal
```

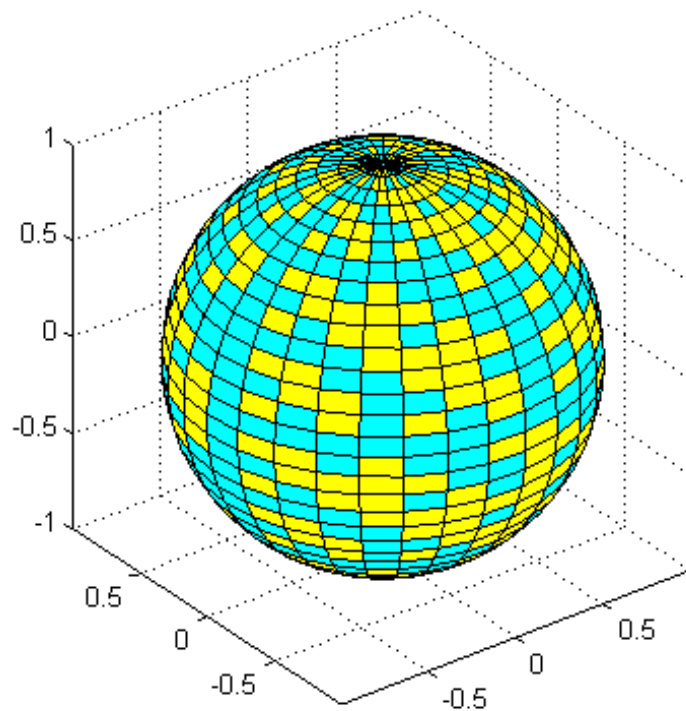

**See Also**

[surf](#) | [axis](#) | [colormap](#) | [griddata](#) | [imagesc](#) | [mesh](#) | [meshgrid](#) | [pcolor](#) | [shading](#) | [trisurf](#) | [scatteredInterpolant](#) | [view](#) | [Surfaceplot Properties](#)

**How To**

- “Representing Data as a Surface”
- “Surface Plots of Nonuniformly Sampled Data”
- Coloring Mesh and Surface Plots

## Purpose

Contour plot under a 3-D shaded surface plot

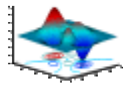

## Syntax

```
surf(Z)
surf(Z,C)
surf(X,Y,Z)
surf(X,Y,Z,C)
surf(...,'PropertyName',PropertyValue)
surf(axes_handles,...)
h = surf(...)
```

## Description

`surf(Z)` creates a contour plot under the three-dimensional shaded surface from the  $z$  components in matrix  $Z$ , using  $x = 1:n$  and  $y = 1:m$ , where  $[m,n] = \text{size}(Z)$ . The height,  $Z$ , is a single-valued function defined over a geometrically rectangular grid.  $Z$  specifies the color data, as well as surface height, so color is proportional to surface height.

`surf(Z,C)` plots the height of  $Z$ , a single-valued function defined over a geometrically rectangular grid, and uses matrix  $C$ , assumed to be the same size as  $Z$ , to color the surface.

`surf(X,Y,Z)` uses  $Z$  for the color data and surface height.  $X$  and  $Y$  are vectors or matrices defining the  $x$  and  $y$  components of a surface. If  $X$  and  $Y$  are vectors,  $\text{length}(X) = n$  and  $\text{length}(Y) = m$ , where  $[m,n] = \text{size}(Z)$ . In this case, the vertices of the surface faces are  $(X(j), Y(i), Z(i,j))$  triples. To create  $X$  and  $Y$  matrices for arbitrary domains, use the `meshgrid` function.

`surf(X,Y,Z,C)` uses  $C$  to define color. MATLAB performs a linear transformation on this data to obtain colors from the current colormap.

`surf(...,'PropertyName',PropertyValue)` specifies surface Surfaceplot along with the data.

`surf(axes_handles,...)` plots into the axes with handle `axes_handle` instead of the current axes (`gca`).

`h = surf(...)` returns a handle to a Surfaceplot graphics object.

## Tips

`surf` does not accept complex inputs.

## Algorithms

Consider a parametric surface parameterized by two independent variables,  $i$  and  $j$ , which vary continuously over a rectangle; for example,  $1 \leq i \leq m$  and  $1 \leq j \leq n$ . The three functions  $x(i, j)$ ,  $y(i, j)$ , and  $z(i, j)$  specify the surface. When  $i$  and  $j$  are integer values, they define a rectangular grid with integer grid points. The functions  $x(i, j)$ ,  $y(i, j)$ , and  $z(i, j)$  become three  $m$ -by- $n$  matrices,  $X$ ,  $Y$ , and  $Z$ . Surface color is a fourth function,  $c(i, j)$ , denoted by matrix  $C$ .

Each point in the rectangular grid can be thought of as connected to its four nearest neighbors.

$$\begin{array}{c}
 i-1, j \\
 | \\
 i, j-1 - i, j - i, j+1 \\
 | \\
 i+1, j
 \end{array}$$

This underlying rectangular grid induces four-sided patches on the surface. To express this another way, `[X(:) Y(:) Z(:)]` returns a list of triples specifying points in 3-D space. Each interior point is connected to the four neighbors inherited from the matrix indexing. Points on the edge of the surface have three neighbors. The four points at the corners of the grid have only two neighbors. This defines a mesh of quadrilaterals or a *quad-mesh*.

You can specify surface color in two different ways: at the vertices or at the centers of each patch. In this general setting, the surface need not be a single-valued function of  $x$  and  $y$ . Moreover, the four-sided surface patches need not be planar. For example, you can have surfaces defined in polar, cylindrical, and spherical coordinate systems.

The shading function sets the shading. If the shading is `interp`,  $C$  must be the same size as  $X$ ,  $Y$ , and  $Z$ ; it specifies the colors at the vertices. The color within a surface patch is a bilinear function of the local

coordinates. If the shading is `faceted` (the default) or `flat`, `C(i,j)` specifies the constant color in the surface patch:

$$\begin{array}{ccc} (i,j) & - & (i,j+1) \\ | & C(i,j) & | \\ (i+1,j) & - & (i+1,j+1) \end{array}$$

In this case, `C` can be the same size as `X`, `Y`, and `Z` and its last row and column are ignored. Alternatively, its row and column dimensions can be one less than those of `X`, `Y`, and `Z`.

The `surf` function specifies the viewpoint using `view(3)`.

The range of `X`, `Y`, and `Z` or the current setting of the axes `XLimMode`, `YLimMode`, and `ZLimMode` properties (also set by the `axis` function) determines the axis labels.

The range of `C` or the current setting of the axes `CLim` and `CLimMode` properties (also set by the `caxis` function) determines the color scaling. The scaled color values are used as indices into the current colormap.

## Examples

### Display Contour Plot Under Surface Plot

Display a contour plot under a surface plot of the `peaks` function.

```
[X,Y,Z] = peaks(30);
figure
surf(X,Y,Z)
```

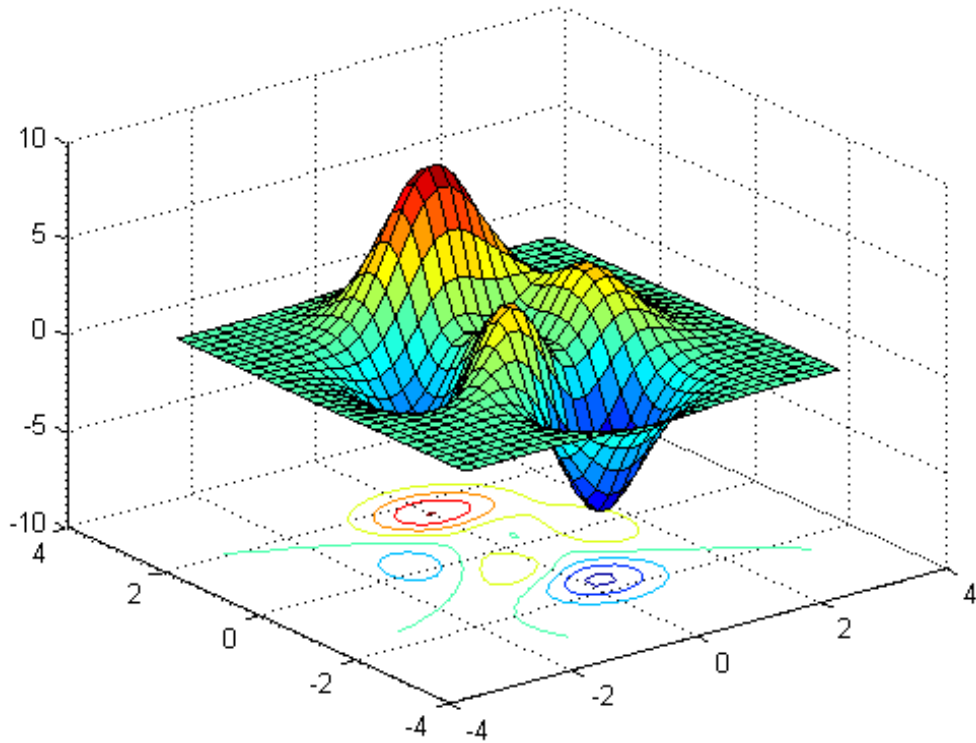
**See Also**

[surf](#) | [axis](#) | [caxis](#) | [colormap](#) | [contour](#) | [delaunay](#) | [imagesc](#) | [mesh](#) | [meshgrid](#) | [pcolor](#) | [shading](#) | [trisurf](#) | [view](#) | [Surfaceplot](#)  
Properties

**How To**

- [Representing a Matrix as a Surface](#)
- [Coloring Mesh and Surface Plots](#)

# surf2patch

---

**Purpose** Convert surface data to patch data

**Syntax**

```
fvc = surf2patch(Z)
fvc = surf2patch(Z,C)
fvc = surf2patch(X,Y,Z)
fvc = surf2patch(X,Y,Z,C)
fvc = surf2patch(...,'triangles')
[f,v,c] = surf2patch(...)
```

**Description** `fvc = surf2patch(h)` converts the geometry and color data from the surface object identified by the handle `h` into patch format and returns the face, vertex, and color data in the struct `fvc`. You can pass this struct directly to the `patch` command.

`fvc = surf2patch(Z)` calculates the patch data from the surface's `ZData` matrix `Z`.

`fvc = surf2patch(Z,C)` calculates the patch data from the surface's `ZData` and `CData` matrices `Z` and `C`.

`fvc = surf2patch(X,Y,Z)` calculates the patch data from the surface's `XData`, `YData`, and `ZData` matrices `X`, `Y`, and `Z`.

`fvc = surf2patch(X,Y,Z,C)` calculates the patch data from the surface's `XData`, `YData`, `ZData`, and `CData` matrices `X`, `Y`, `Z`, and `C`.

`fvc = surf2patch(...,'triangles')` creates triangular faces instead of the quadrilaterals that compose surfaces.

`[f,v,c] = surf2patch(...)` returns the face, vertex, and color data in the three arrays `f`, `v`, and `c` instead of a struct.

**Examples** The first example uses the `sphere` command to generate the `XData`, `YData`, and `ZData` of a surface, which is then converted to a patch. Note that the `ZData` (`z`) is passed to `surf2patch` as both the third and fourth arguments — the third argument is the `ZData` and the fourth argument is taken as the `CData`. This is because the `patch` command does not



automatically use the  $z$ -coordinate data for the color data, as does the `surface` command.

Also, because `patch` is a low-level command, you must set the view to 3-D and shading to `faceted` to produce the same results produced by the `surf` command.

```
[x y z] = sphere;
patch(surf2patch(x,y,z,z));
shading faceted; view(3)
```

In the second example `surf2patch` calculates face, vertex, and color data from a surface whose handle has been passed as an argument.

```
s = surf(peaks);
pause
patch(surf2patch(s));
delete(s)
shading faceted; view(3)
```

## See Also

`patch` | `reducepatch` | `shrinkfaces` | `surface` | `surf`

# surface

---

**Purpose** Create surface object

**Syntax**

```
surface(Z)
surface(Z,C)
surface(X,Y,Z)
surface(X,Y,Z,C)
surface(x,y,Z)
surface(... 'PropertyName',PropertyValue,...)
h = surface(...)
```

**Properties** For a list of properties, see `Surface Properties`.

**Description** `surface` is the low-level function for creating surface graphics objects. Surfaces are plots of matrix data created using the row and column indices of each element as the  $x$ - and  $y$ -coordinates and the value of each element as the  $z$ -coordinate.

`surface(Z)` plots the surface specified by the matrix  $Z$ . Here,  $Z$  is a single-valued function, defined over a geometrically rectangular grid.

`surface(Z,C)` plots the surface specified by  $Z$  and colors it according to the data in  $C$  (see "Examples").

`surface(X,Y,Z)` uses  $C = Z$ , so color is proportional to surface height above the  $x$ - $y$  plane.

`surface(X,Y,Z,C)` plots the parametric surface specified by  $X$ ,  $Y$ , and  $Z$ , with color specified by  $C$ .

`surface(x,y,Z)`, `surface(x,y,Z,C)` replaces the first two matrix arguments with vectors and must have `length(x) = n` and `length(y) = m` where `[m,n] = size(Z)`. In this case, the vertices of the surface facets are the triples  $(x(j), y(i), Z(i,j))$ . Note that  $x$  corresponds to the columns of  $Z$  and  $y$  corresponds to the rows of  $Z$ . For a complete discussion of parametric surfaces, see the `surf` function.

`surface(... 'PropertyName',PropertyValue,...)` follows the  $X$ ,  $Y$ ,  $Z$ , and  $C$  arguments with property name/property value pairs to specify

additional surface properties. For a description of the properties, see `Surface Properties`.

`h = surface(...)` returns a handle to the created surface object.

## Tips

`surface` does not respect the settings of the figure and axes `NextPlot` properties. It simply adds the surface object to the current axes.

If you do not specify separate color data (C), MATLAB uses the matrix (Z) to determine the coloring of the surface. In this case, color is proportional to values of Z. You can specify a separate matrix to color the surface independently of the data defining the area of the surface.

You can specify properties as property name/property value pairs, structure arrays, and cell arrays (see `set` and `get` for examples of how to specify these data types).

`surface` provides convenience forms that allow you to omit the property name for the `XData`, `YData`, `ZData`, and `CData` properties. For example,

```
surface('XData',X,'YData',Y,'ZData',Z,'CData',C)
```

is equivalent to

```
surface(X,Y,Z,C)
```

When you specify only a single matrix input argument,

```
surface(Z)
```

MATLAB assigns the data properties as if you specified

```
surface('XData',[1:size(Z,2)],...
 'YData',[1:size(Z,1)],...
 'ZData',Z,...
 'CData',Z)
```

The `axis`, `caxis`, `colormap`, `hold`, `shading`, and `view` commands set graphics properties that affect surfaces. You can also set and query

# surface

---

surface property values after creating them using the `set` and `get` commands.

## Examples

### Create Surface Plot

Plot the function  $z = xe^{-x^2-y^2}$  on the domain  $-2 \leq x \leq 2$  and  $-2 \leq y \leq 2$ . Use `meshgrid` to define `X` and `Y`. Then, define `Z` and create a surface plot. Change the view of the plot using `view`.

```
[X,Y] = meshgrid(-2:0.2:2,-2:0.2:2);
Z = X.*exp(-X.^2 - Y.^2);
figure
surface(X,Y,Z);
view(3)
```

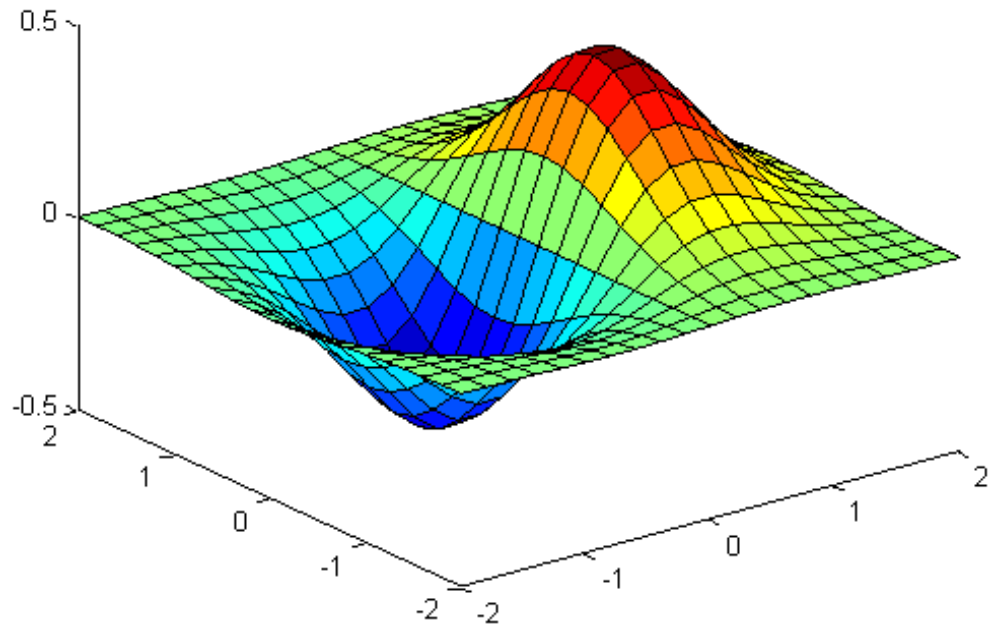

`surface` creates the plot from corresponding values in X, Y, and Z. If you do not define the color data C, then `surface` uses Z to determine the color, so color is proportional to surface height.

### Display Image Along Surface Plot

Use the `peaks` function to define XD, YD, and ZD as 25-by-25 matrices.

```
[XD,YD,ZD] = peaks(25);
```

## surface

---

Load the clown data set to get the image data `X` and its associated colormap, `map`. Flip `X` using the `flipud` function and define the flipped image as the color data for the surface, `C`.

```
load clown
C = flipud(X);
```

Create a surface plot and display the image along the surface. Since the surface data `ZD` and the color data `C` have different dimensions, you must set the surface `FaceColor` to `'texturemap'`.

```
figure
surface(XD,YD,ZD,C,...
 'FaceColor','texturemap',...
 'EdgeColor','none',...
 'CDataMapping','direct')
colormap(map);
view(-35,45);
```

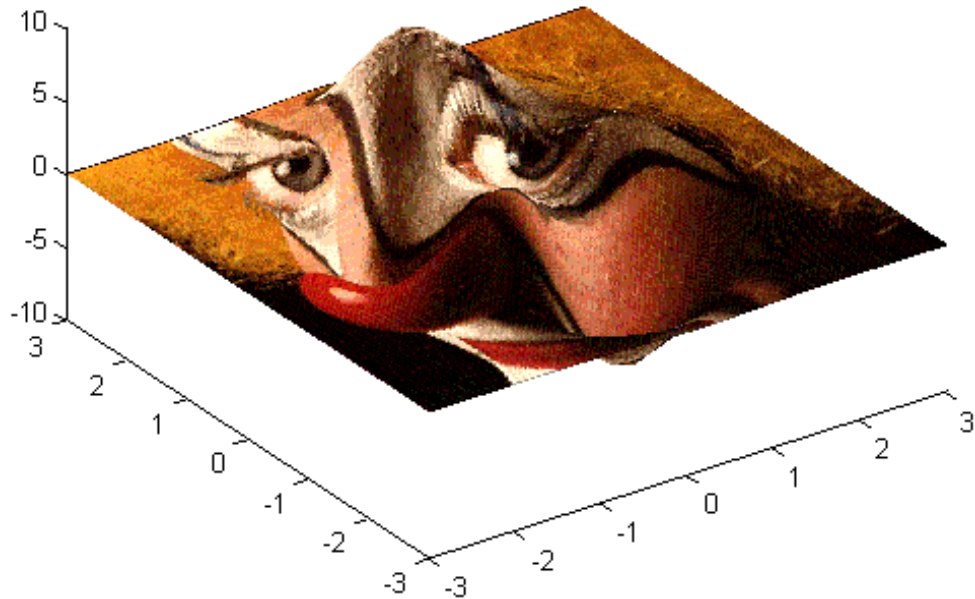

The clown data is typically viewed with the `image` function, which uses 'ij' axis numbering. This example reverses the image data in the vertical direction using `flipud`.

## Setting Default Properties

You can set default surface properties on the axes, figure, and root object levels:

```
set(0, 'DefaultSurfaceProperty', PropertyValue...)
set(gcf, 'DefaultSurfaceProperty', PropertyValue...)
set(gca, 'DefaultSurfaceProperty', PropertyValue...)
```

# surface

---

where *Property* is the name of the surface property whose default value you want to set and *PropertyValue* is the value you are specifying. Use `set` and `get` to access the surface properties.

## Tutorials

For examples, see [Representing a Matrix as a Surface](#).

## See Also

[ColorSpec](#) | [patch](#) | [pcolor](#) | [surf](#) | [Surface Properties](#)



## Purpose

Surface properties

## Creating Surface Objects

Use `surface` to create surface objects.

## Modifying Properties

You can set and query graphics object properties in two ways:

- Property Editor is an interactive tool that enables you to see and change object property values.
- The `set` and `get` commands enable you to set and query the values of properties.

To change the default values of properties, see [Setting Default Property Values](#).

See “Core Graphics Objects” for general information about this type of object.

## Surface Property Descriptions

This section provides a description of properties. Curly braces { } enclose default values.

`AlphaData`

`m-by-n matrix of double or uint8`

*Transparency data.* A matrix of non-NaN values specifying the transparency of each face or vertex of the object. The `AlphaData` can be of class `double` or `uint8`.

MATLAB software determines the transparency in one of the following ways:

- Using the elements of `AlphaData` as transparency values (`AlphaDataMapping` set to `none`)
- Using the elements of `AlphaData` as indices into the current `alphamap` (`AlphaDataMapping` set to `direct`)

# Surface Properties

---

- Scaling the elements of `AlphaData` to range between the minimum and maximum values of the axes `ALim` property (`AlphaDataMapping` set to `scaled`, the default)

`AlphaDataMapping`

`none` | `direct` | `{scaled}`

*Transparency mapping method.* Determines how MATLAB interprets indexed alpha data.

- `none` — The transparency values of `AlphaData` are between 0 and 1 or are clamped to this range (the default).
- `scaled` — Transform the `AlphaData` to span the portion of the `alphamap` indicated by the axes `ALim` property, linearly mapping data values to alpha values.
- `direct` — Use the `AlphaData` as indices directly into the `alphamap`. When not scaled, the data are usually integer values ranging from 1 to `length(alphamap)`. MATLAB maps values less than 1 to the first alpha value in the `alphamap`, and values greater than `length(alphamap)` to the last alpha value in the `alphamap`. Values with a decimal portion are fixed to the nearest lower integer. If `AlphaData` is an array of `uint8` integers, then the indexing begins at 0 (that is, MATLAB maps a value of 0 to the first alpha value in the `alphamap`).

`AmbientStrength`

scalar  $\geq 0$  and  $\leq 1$

*Strength of ambient light.* Sets the strength of the ambient light, which is a nondirectional light source that illuminates the entire scene. You must have at least one visible light object in the axes for the ambient light to be visible. The axes `AmbientLightColor` property sets the color of the ambient light, which is therefore the same on all objects in the axes.

You can also set the strength of the diffuse and specular contribution of light objects. See the surface `DiffuseStrength` and `SpecularStrength` properties.

## Annotation

`hg.Annotation` object (read-only)

*Handle of Annotation object.* The `Annotation` property enables you to specify whether this surface object is represented in a figure legend.

Querying the `Annotation` property returns the handle of an `hg.Annotation` object. The `hg.Annotation` object has a property called `LegendInformation`, which contains an `hg.LegendEntry` object.

Once you have obtained the `hg.LegendEntry` object, you can set its `IconDisplayStyle` property to control whether the surface object is displayed in a figure legend:

<b>IconDisplayStyle Value</b>	<b>Purpose</b>
on	Represent this surface object in a legend (default)
off	Do not include this surface object in a legend
children	Same as on because surface objects do not have children

## Setting the `IconDisplayStyle` property

Set the `IconDisplayStyle` of a graphics object with handle `hobj` to `off`:

```
hAnnotation = get(hobj, 'Annotation');
hLegendEntry = get(hAnnotation, 'LegendInformation');
set(hLegendEntry, 'IconDisplayStyle', 'off')
```

# Surface Properties

---

## Using the `IconDisplayStyle` property

See “Control Legend Content” for more information and examples.

`BackFaceLighting`  
`unlit | lit | {reverselit}`

*Face lighting control.* Determines how faces are lit when their vertex normals point away from the camera.

- `unlit` — Face not lit.
- `lit` — Face lit in normal way.
- `reverselit` — Face lit as if the vertex pointed towards the camera.

Use this property to discriminate between the internal and external surfaces of an object. See “Back Face Lighting” for an example.

`BeingDeleted`  
`on | {off}` (read-only)

*This object is being deleted.* Mechanism to determine if objects are in the process of being deleted. MATLAB sets the `BeingDeleted` property to `on` when the object’s delete function callback is called (see the `DeleteFcn` property). It remains set to `on` while the delete function executes, after which the object no longer exists.

For example, an object’s delete function calls other functions that act on a number of different objects. If a function does not need to perform an action on an about-be-deleted object, it can check the object’s `BeingDeleted` property before acting.

`BusyAction`  
`cancel | {queue}`

*Callback queuing*

Determines how MATLAB handles the execution of interrupting callbacks.

A *running* callback is the currently executing callback. The *interrupting* callback is the callback that tries to interrupt the *running* callback. The `BusyAction` property of the *interrupting* callback determines how MATLAB handles its execution. When the `BusyAction` property is set to:

- 'queue' — Puts the *interrupting* callback in a queue to be processed after the *running* callback finishes execution.
- 'cancel' — Discards the *interrupting* callback as MATLAB finishes execution.

For information about how the `Interruptible` property of the callback controls whether other callbacks can interrupt the *running* callback, see the `Interruptible` property description.

## `ButtonDownFcn`

function handle | cell array containing function handle and additional arguments | string (not recommended)

*Button press callback function.* Executes whenever you press a mouse button while the pointer is over the surface object.

See the figure's `SelectionType` property to determine if modifier keys were also pressed.

Set this property to a function handle that references the callback. The function must define at least two input arguments (handle of object associated with the button down event and an event structure, which is empty for this property).

The following example shows how to access the callback object's handle as well as the handle of the figure that contains the object from the callback function.

```
function button_down(src,evnt)
% src - the object that is the source of the event
```

# Surface Properties

---

```
% evnt - empty for this property
sel_typ = get(gcf,'SelectionType')
switch sel_typ
 case 'normal'
 disp('User clicked left-mouse button')
 set(src,'Selected','on')
 case 'extend'
 disp('User did a shift-click')
 set(src,'Selected','on')
 case 'alt'
 disp('User did a control-click')
 set(src,'Selected','on')
 set(src,'SelectionHighlight','off')
end
end
```

Suppose `h` is the handle of a surface object and the `button_down` function is on your MATLAB path. The following statement assigns the `button_down` function to the `ButtonDownFcn` property:

```
set(h,'ButtonDownFcn',@button_down)
```

For information on the syntax of callback functions, see [Function Handle Callbacks](#).

**CData**  
matrix (of type double)

*Vertex colors.* Values that specify the color at every point in `ZData`.

## Mapping CData to a Colormap

You can specify color as indexed values or true color. Indexed color data specifies a single value for each vertex. These values are either scaled to map linearly into the current colormap (see `caxis`) or interpreted directly as indices into the colormap, depending on the setting of the `CDataMapping` property.

## CData as True Color

True color defines an RGB value for each vertex. If the coordinate data (XData, for example) are contained in  $m$ -by- $n$  matrices, then CData must be an  $m$ -by- $n$ -by-3 array. The first page contains the red components, the second the green components, and the third the blue components of the colors.

## Texturemapping the Surface FaceColor

If you set the FaceColor property to texturemap, CData does not need to be the same size as ZData, but must be of type double or uint8. In this case, MATLAB maps CData to conform to the surface defined by ZData.

CDataMapping  
{scaled} | direct

*Direct or scaled color mapping.* Determines how MATLAB interprets indexed color data used to color the surface. (If you use true color specification for CData, this property has no effect.)

- **scaled** — Transform the color data to span the portion of the colormap indicated by the axes CLim property, linearly mapping data values to colors. See the caxis reference page for more information on this mapping.
- **direct** — Use the color data as indices directly into the colormap. The color data should then be integer values ranging from 1 to length(colormap). MATLAB maps values less than 1 to the first color in the colormap, and values greater than length(colormap) to the last color in the colormap. Values with a decimal portion are fixed to the nearest lower integer.

Children  
matrix of handles

Always the empty matrix; surface objects have no children.

# Surface Properties

---

## Clipping

{on} | off

*Clipping to axes rectangle.* When `Clipping` is on, MATLAB does not display any portion of the surface that is outside the axes rectangle.

## CreateFcn

function handle | cell array containing function handle and additional arguments | string (not recommended)

*Callback function executed during object creation.* Executes when MATLAB creates a surface object. You must define this property as a default value for surfaces or set the `CreateFcn` property during object creation.

For example, the following statement creates a surface (assuming `x`, `y`, `z`, and `c` are defined), and executes the function referenced by the function handle `@myCreateFcn`.

```
surface(x,y,z,c,'CreateFcn',@myCreateFcn)
```

MATLAB executes this routine after setting all surface properties. Setting this property on an existing surface object has no effect.

The handle of the object whose `CreateFcn` is being executed is passed by MATLAB as the first argument to the callback function and is also accessible through the root `CallbackObject` property, which you can query using `gcbo`.

For information on the syntax of callback functions, see [Function Handle Callbacks](#).

## DeleteFcn

function handle | cell array containing function handle and additional arguments | string (not recommended)



*Delete surface callback function.* Executes when you delete the surface object (for example, when you issue a `delete` command or clear the axes `cla` or figure `clf`).

For example, the following function displays object property data before the object is deleted.

```
function delete_fcn(src, evnt)
% src - the object that is the source of the event
% evnt - empty for this property
 obj_tp = get(src, 'Type');
 disp([obj_tp, ' object deleted'])
 disp('Its user data is:')
 disp(get(src, 'UserData'))
end
```

MATLAB executes the function before deleting the object's properties so these values are available to the callback function. The function must define at least two input arguments (handle of object being deleted and an event structure, which is empty for this property).

The handle of the object whose `DeleteFcn` is being executed is passed by MATLAB as the first argument to the callback function and is also accessible through the root `CallbackObject` property, which you can query using `gcbo`.

For information on the syntax of callback functions, see [Function Handle Callbacks](#).

## `DiffuseStrength`

scalar  $\geq 0$  and  $\leq 1$

*Intensity of diffuse light.* Sets the intensity of the diffuse component of the light falling on the surface. Diffuse light comes from light objects in the axes. Default value is 0.6.

# Surface Properties

---

You can also set the intensity of the ambient and specular components of the light on the object. See the `AmbientStrength` and `SpecularStrength` properties.

`DisplayName`  
string

*String used by legend.* The `legend` function uses the `DisplayName` property to label the surface object in the legend. The default is an empty string.

- If you specify string arguments with the `legend` function, MATLAB set `DisplayName` to the corresponding string and uses that string for the legend.
- If `DisplayName` is empty, `legend` creates a string of the form, `['data' n]`, where `n` is the number assigned to the object based on its location in the list of legend entries. However, `legend` does not set `DisplayName` to this string.
- If you edit the string directly in an existing legend, MATLAB set `DisplayName` to the edited string.
- If you specify a string for the `DisplayName` property and create the legend using the figure toolbar, then MATLAB uses the string defined by `DisplayName`.
- To add a legend programmatically that uses the `DisplayName` string, call `legend` with the `toggle` or `show` option.

See “Control Legend Content” for more information and examples.

`EdgeAlpha`  
{scalar = 1} | flat | interp

*Transparency of the surface edges.*

- scalar — A single non-`NaN` scalar value between 0 and 1 that controls the transparency of all the edges of the object. 1 (the default) means fully opaque and 0 means completely transparent.

- `flat` — The alpha data (`AlphaData`) value for the first vertex of the face determines the transparency of the edges.
- `interp` — Linear interpolation of the alpha data (`AlphaData`) values at each vertex determines the transparency of the edge.

Note that you must specify `AlphaData` as a matrix equal in size to `ZData` to use `flat` or `interp` `EdgeAlpha`.

## EdgeColor

`{ColorSpec} | none | flat | interp`

*Color of the surface edge.* Determines how MATLAB colors the edges of the individual faces that make up the surface.

- `ColorSpec` — A three-element RGB vector or one of the MATLAB predefined names, specifying a single color for edges. The default value is `[0 0 0]` (black). See `ColorSpec` for more information on specifying color.
- `none` — Edges not drawn.
- `flat` — The `CData` value of the first vertex for a face determines the color of each edge.

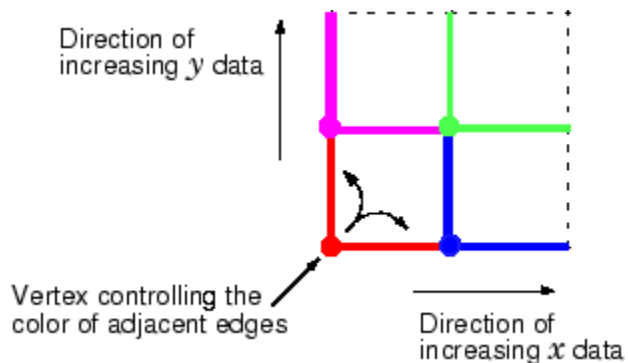

- `interp` — Linear interpolation of the `CData` values at the face vertices determines the edge color.

# Surface Properties

---

## EdgeLighting

{none} | flat | gouraud | phong

*Algorithm used for lighting calculations.* Selects the algorithm used to calculate the effect of light objects on surface edges.

- none — Lights do not affect the edges of this object.
- flat — The effect of light objects is uniform across each edge of the surface.
- gouraud — The effect of light objects is calculated at the vertices and then linearly interpolated across the edge lines.
- phong — The effect of light objects is determined by interpolating the vertex normals across each edge line and calculating the reflectance at each pixel. Phong lighting generally produces better results than Gouraud lighting, but takes longer to render.

## EraseMode

{normal} | none | xor | background

*Erase mode.* Controls the technique MATLAB uses to draw and erase surface objects. Alternative erase modes are useful for creating animated sequences, where control of the way individual objects are redrawn is necessary to improve performance and obtain the desired effect.

- normal — Redraw the affected region of the display, performing the three-dimensional analysis necessary to ensure that all objects are rendered correctly. This mode produces the most accurate picture, but is the slowest. The other modes are faster, but do not perform a complete redraw and are therefore less accurate.
- none — Do not erase the surface when it is moved or destroyed. While the object is still visible on the screen after erasing with EraseMode none, you cannot print it because MATLAB stores no information about its former location.

- `xor` — Draw and erase the surface by performing an exclusive OR (XOR) with each pixel index of the screen behind it. Erasing the surface does not damage the color of the objects behind it. However, surface color depends on the color of the screen behind it and is correctly colored only when over the axes background `Color`, or the figure background `Color` if the axes `Color` is none.
- `background` — Erase the surface by drawing it in the axes background `Color`, or the figure background `Color` if the axes `Color` is set to none. This damages objects that are behind the erased object, but surface objects are always properly colored.

## Printing with Nonnormal Erase Modes

MATLAB always prints figures as if the `EraseMode` of all objects is `normal`. This means graphics objects created with `EraseMode` set to `none`, `xor`, or `background` can look different on screen than on paper. On screen, MATLAB mathematically combines layers of colors (for example, performing an XOR on a pixel color with that of the pixel behind it) and ignore three-dimensional sorting to obtain greater rendering speed. However, these techniques are not applied to the printed output.

You can use the `getframe` command or other screen capture applications to create an image of a figure containing nonnormal mode objects.

## FaceAlpha

`{scalar = 1} | flat | interp | texturemap`

*Transparency of the surface faces.*

- `scalar` — A single non-`NaN` scalar value between 0 and 1 that controls the transparency of all the faces of the object. 1 (the default) means fully opaque and 0 means completely transparent (invisible).

# Surface Properties

---

- `flat` — The values of the alpha data (`AlphaData`) determine the transparency for each face. The alpha data at the first vertex determine the transparency of the entire face.
- `interp` — Bilinear interpolation of the alpha data (`AlphaData`) at each vertex determines the transparency of each face.
- `texturemap` — Use transparency for the texture map.

Note that you must specify `AlphaData` as a matrix equal in size to `ZData` to use `flat` or `interp` `FaceAlpha`.

## `FaceColor`

`ColorSpec` | `none` | `{flat}` | `interp` | `texturemap`

*Color of the surface face.*

- `ColorSpec` — A three-element RGB vector or one of the MATLAB predefined names, specifying a single color for faces. See the `ColorSpec` reference page for more information on specifying color.
- `none` — Do not draw faces. Note that edges are drawn independently of faces.
- `flat` — The values of `CData` determine the color for each face of the surface. The color data at the first vertex determine the color of the entire face.
- `interp` — Bilinear interpolation of the values at each vertex (the `CData`) determines the coloring of each face.
- `texturemap` — Texture map the `CData` to the surface. MATLAB transforms the color data so that it conforms to the surface. (See the texture mapping example.)

## `FaceLighting`

`none` | `{flat}` | `gouraud` | `phong`

*Algorithm used for lighting calculations.* Selects the algorithm used to calculate the effect of light objects on the surface.

- `none` — Lights do not affect the faces of this object.
- `flat` — The effect of light objects is uniform across the faces of the surface. Select this choice to view faceted objects.
- `gouraud` — The effect of light objects is calculated at the vertices and then linearly interpolated across the faces. Select this choice to view curved surfaces.
- `phong` — The effect of light objects is determined by interpolating the vertex normals across each face and calculating the reflectance at each pixel. Select this choice to view curved surfaces. Phong lighting generally produces better results than Gouraud lighting, but takes longer to render.

## HandleVisibility

`{on} | callback | off`

*Control access to object's handle.* Determines when an object's handle is visible in its parent's list of children. This property is useful for preventing command-line users from accidentally drawing into or deleting a figure that contains only user interface devices (such as a dialog box).

- `on` — Handles are always visible.
- `callback` — Handles are visible from within callback routines or functions invoked by callback routines, but not from within functions invoked from the command line. This provides a means to protect GUIs from command-line users, while allowing callback routines to have access to object handles.
- `off` — Handles are invisible at all times. Use this option when a callback invokes a function that could damage the GUI (such as evaluating a user-typed string). This option temporarily hides its own handles during the execution of that function.

When a handle is not visible in its parent's list of children, it cannot be returned by functions that obtain handles by searching

# Surface Properties

---

the object hierarchy or querying handle properties. This includes `get`, `findobj`, `gca`, `gcf`, `gco`, `newplot`, `cla`, `clf`, and `close`.

When a handle's visibility is restricted using `callback` or `off`, the object's handle does not appear in its parent's `Children` property, figures do not appear in the root's `CurrentFigure` property, objects do not appear in the root's `CallbackObject` property or in the figure's `CurrentObject` property, and axes do not appear in their parent's `CurrentAxes` property.

You can set the root `ShowHiddenHandles` property to `on` to make all handles visible, regardless of their `HandleVisibility` settings (this does not affect the values of the `HandleVisibility` properties).

Handles that are hidden are still valid. If you know an object's handle, you can set and get its properties, and pass it to any function that operates on handles.

`HitTest`  
`{on} | off`

*Selectable by mouse click.* Determines if the surface can become the current object (as returned by the `gco` command and the figure `CurrentObject` property) as a result of a mouse click on the surface. If `HitTest` is `off`, clicking on the surface selects the object below it (which might be the axes containing it).

`Interruptible`  
`off | {on}`

*Callback routine interruption*

Controls whether MATLAB can interrupt an object's callback function when subsequent callbacks attempt to interrupt it.

For Graphics objects, the `Interruptible` property affects only the callbacks for the `ButtonDownFcn` property. A *running* callback is



the currently executing callback. The *interrupting* callback is the callback that tries to interrupt the *running* callback. MATLAB handles both the callbacks based on the `Interruptible` property of the object of the *running* callback.

When the `Interruptible` property is set to:

- 'off', MATLAB finishes execution of the *running* callback without any interruptions
- 'on', these conditions apply:
  - If there is a `drawnow`, `figure`, `getframe`, `waitfor`, or `pause` command in the *running* callback, then MATLAB executes the *interrupting* callbacks which are already in the queue and returns to finish execution of the current callback.
  - If one of the above functions is not in the *running* callback, then MATLAB finishes execution of the current callback without any interruption.

`BusyAction` property of the object of interrupting callback determines whether the callback should be ignored or should be put in the queue.

Setting `Interruptible` property to on (default), allows a callback from other graphics objects to interrupt callback functions originating from this object.

---

**Note** MATLAB does not save the state of properties or the display when an interruption occurs. For example, the handle returned by the `gca` or `gcf` command may be changed as another callback is executed.

---

After the function that interrupts a callback completes, the callback resumes execution where it halted when interrupted.

# Surface Properties

---

For more information, see “Control Callback Execution and Interruption”.

## LineStyle

{-} | -- | : | -. | none

*Line style of surface edges.*

### Line Style Specifiers Table

Specifier	Line Style
'-'	Solid line (default)
'--'	Dashed line
':'	Dotted line
'-.'	Dash-dot line
'none'	No line

## LineWidth

size in points

*Edge line width.* The width of the lines in points used to draw surface edges. The default width is 0.5 points. 1 point =  $\frac{1}{72}$  inch.

## Marker

character (see table)

*Marker symbol.* Specifies symbols that are displayed at vertices. You can set values for the Marker property independently from the LineStyle property. For a list of supported marker symbols, see the following table.

## Marker Specifiers Table

Specifier	Marker Type
'+'	Plus sign
'o'	Circle
'*'	Asterisk
'.'	Point
'x'	Cross
'square' or 's'	Square
'diamond' or 'd'	Diamond
'^'	Upward-pointing triangle
'v'	Downward-pointing triangle
'>'	Right-pointing triangle
'<'	Left-pointing triangle
'pentagram' or 'p'	Five-pointed star (pentagram)
'hexagram' or 'h' ' ' '	Six-pointed star (hexagram)
'none'	No marker (default)

### MarkerEdgeColor

none | {auto} | flat | ColorSpec

*Marker edge color.* The color of the marker or the edge color for filled markers (circle, square, diamond, pentagram, hexagram, and the four triangles).

- none — Specifies no color, which makes nonfilled markers invisible.
- auto — Uses same color as the EdgeColor property.
- flat — Uses the CData value of the vertex to determine the color of the marker edge.

# Surface Properties

---

- `ColorSpec` — Defines color to use.

`MarkerFaceColor`

`{none} | auto | flat | ColorSpec`

*Marker face color.* The fill color for markers that are closed shapes (circle, square, diamond, pentagram, hexagram, and the four triangles).

- `none` — Makes the interior of the marker transparent, allowing the background to show through.
- `auto` — Uses the axes `Color` for the marker face color.
- `flat` — Uses the `CData` value of the vertex to determine the color of the face.
- `ColorSpec` — Defines a single color to use for all markers on the surface.

`MarkerSize`

scalar

*Marker size.* Size of the marker in points. The default value is 6.

---

**Note** MATLAB draws the point marker (specified by the `'.'` symbol) at one-third the specified size.

---

`MeshStyle`

`{both} | row | column`

*Row and column lines.* Specifies whether to draw all edge lines or just row or column edge lines.

- `both` — Draws edges for both rows and columns.
- `row` — Draws row edges only.
- `column` — Draws column edges only.

## NormalMode

{auto} | manual

*MATLAB generated or user-specified normal vectors.*

- **auto** — MATLAB calculates vertex normals based on the coordinate data
- **manual** — If you specify your own vertex normals, MATLAB sets this property to **manual** and does not generate its own data.

See also the `VertexNormals` property.

## Parent

handle of axes, hggroup, or hgtransform

*Parent of surface object.* Contains the handle of the surface object's parent. The parent of a surface object is the axes, hggroup, or hgtransform object that contains it.

## Selected

on | {off}

*Is object selected?* When this property is on, MATLAB displays a dashed bounding box around the surface if the `SelectionHighlight` property is also on. You can, for example, define the `ButtonDownFcn` to set this property, allowing users to select the object with the mouse.

## SelectionHighlight

{on} | off

*Objects are highlighted when selected.* When the `Selected` property is on, MATLAB indicates the selected state by drawing a dashed bounding box around the surface. When `SelectionHighlight` is off, MATLAB does not draw the box.

## SpecularColorReflectance

scalar in the range 0 to 1

# Surface Properties

---

*Color of specularly-reflected light.* When this property is 0, the color of the specularly-reflected light depends on both the color of the object from which it reflects and the color of the light source. When set to 1, the color of the specularly-reflected light depends only on the color of the light source (that is, the light object `Color` property). The proportions vary linearly for values in between.

**SpecularExponent**

scalar  $\geq 1$

*Harshness of specular reflection.* Controls the size of the specular spot. Most materials have exponents in the range of 5 to 20.

**SpecularStrength**

scalar  $\geq 0$  and  $\leq 1$

*Intensity of specular light.* Sets the intensity of the specular component of the light falling on the surface. Specular light comes from light objects in the axes.

You can also set the intensity of the ambient and diffuse components of the light on the surface object. See the `AmbientStrength` and `DiffuseStrength` properties. Also see the `material` function.

**Tag**

string

*User-specified object label.* Provides a means to identify graphics objects with a user-specified label. The default is an empty string.

Use the `Tag` property and the `findobj` function to manipulate specific objects within a plotting hierarchy.

**Type**

string (read-only)

*Class of the graphics object.* String that identifies the class of the graphics object. Use this property to find all objects of a given

type within a plotting hierarchy. For surface objects, Type is always 'surface'.

## UIContextMenu

handle of uicontextmenu object

*Associate a context menu with the surface.* Assign this property the handle of a uicontextmenu object created in the same figure as the surface. Use the uicontextmenu function to create the context menu. MATLAB displays the context menu whenever you right-click over the surface.

## UserData

matrix

*User-specified data.* Data you want to associate with the surface object. The default value is an empty array. MATLAB does not use this data, but you can access it using the set and get commands.

## VertexNormals

vector | matrix

*Surface normal vectors.* The vertex normals for the surface. MATLAB generates this data to perform lighting calculations. You can supply your own vertex normal data, even if it does not match the coordinate data. This can be useful to produce interesting lighting effects.

## Visible

{on} | off

*Surface object visibility.* By default, all surfaces are visible. When set to off, the surface is not visible, but still exists, and you can query and set its properties.

## XData

vector | matrix

# Surface Properties

---

*X-coordinates.* The  $x$ -position of the surface points. If you specify a row vector, `surface` replicates the row internally until it has the same number of columns as `ZData`.

`YData`

vector | matrix

*Y-coordinates.* The  $y$ -position of the surface points. If you specify a row vector, `surface` replicates the row internally until it has the same number of rows as `ZData`.

`ZData`

matrix

*Z-coordinates.* The  $z$ -position of the surface data points. See the `Description` section for more information.

## See Also

`surface`



## Purpose

Define surfaceplot properties

## Modifying Properties

You can set and query graphics object properties in two ways:

- The Property Editor is an interactive tool that enables you to see and change object property values.
- The `set` and `get` commands enable you to set and query the values of properties.

Note that you cannot define default properties for surfaceplot objects.

See Plot Objects for information on surfaceplot objects.

## Surfaceplot Property Descriptions

This section provides a description of properties. Curly braces { } enclose default values.

`AlphaData`

m-by-n matrix of `double` or `uint8`

*Transparency data.* A matrix of non-NaN values specifying the transparency of each face or vertex of the object. The `AlphaData` can be of class `double` or `uint8`.

MATLAB software determines the transparency in one of the following ways:

- Using the elements of `AlphaData` as transparency values (`AlphaDataMapping` set to `none`)
- Using the elements of `AlphaData` as indices into the current `alphamap` (`AlphaDataMapping` set to `direct`)
- Scaling the elements of `AlphaData` to range between the minimum and maximum values of the axes `ALim` property (`AlphaDataMapping` set to `scaled`, the default)

`AlphaDataMapping`

`none` | `direct` | `{scaled}`

# Surfaceplot Properties

---

*Transparency mapping method.* Determines how MATLAB interprets indexed alpha data. Values for this property are:

- `none` — The transparency values of `AlphaData` are between 0 and 1 or are clamped to this range.
- `scaled` — Transform the `AlphaData` to span the portion of the `alphamap` indicated by the axes `ALim` property, linearly mapping data values to alpha values (the default).
- `direct` — Use the `AlphaData` as indices directly into the `alphamap`. When not scaled, the data are usually integer values ranging from 1 to `length(alphamap)`. MATLAB maps values less than 1 to the first alpha value in the `alphamap`, and values greater than `length(alphamap)` to the last alpha value in the `alphamap`. Values with a decimal portion are fixed to the nearest, lower integer. If `AlphaData` is an array of `uint8` integers, then the indexing begins at 0 (that is, MATLAB maps a value of 0 to the first alpha value in the `alphamap`).

`AmbientStrength`

scalar  $\geq 0$  and  $\leq 1$

*Strength of ambient light.* Sets the strength of the ambient light, which is a nondirectional light source that illuminates the entire scene. You must have at least one visible light object in the axes for the ambient light to be visible. The axes `AmbientLightColor` property sets the color of the ambient light, which is therefore the same on all objects in the axes.

You can also set the strength of the diffuse and specular contribution of light objects. See the `surfaceplot` `DiffuseStrength` and `SpecularStrength` properties.

`Annotation`

`hg.Annotation` object (read-only)

*Handle of Annotation object.* The Annotation property enables you to specify whether this surfaceplot object is represented in a figure legend.

Querying the Annotation property returns the handle of an hg.Annotation object. The hg.Annotation object has a property called LegendInformation, which contains an hg.LegendEntry object.

Once you have obtained the hg.LegendEntry object, you can set its IconDisplayStyle property to control whether the surfaceplot object is displayed in a figure legend:

IconDisplayStyle Value	Purpose
on	Represent this surfaceplot object in a legend (default)
off	Do not include this surfaceplot object in a legend
children	Same as on because surfaceplot objects do not have children

## Setting the IconDisplayStyle property

Set the IconDisplayStyle of a graphics object with handle hobj to off:

```
hAnnotation = get(hobj, 'Annotation');
hLegendEntry = get(hAnnotation, 'LegendInformation');
set(hLegendEntry, 'IconDisplayStyle', 'off')
```

## Using the IconDisplayStyle property

See “Control Legend Content” for more information and examples.

# Surfaceplot Properties

---

## BackFaceLighting

unlit | lit | {reverselit}

*Face lighting control.* Determines how faces are lit when their vertex normals point away from the camera.

- unlit — Face not lit.
- lit — Face lit in normal way.
- reverselit — Face lit as if the vertex pointed towards the camera.

Use this property to discriminate between the internal and external surfaces of an object. See “Back Face Lighting” for an example.

## BeingDeleted

on | {off} (read-only)

*This object is being deleted.* Mechanism to determine if objects are in the process of being deleted. MATLAB sets the `BeingDeleted` property to `on` when the object’s delete function callback is called (see the `DeleteFcn` property). It remains set to `on` while the delete function executes, after which the object no longer exists.

For example, an object’s delete function calls other functions that act on a number of different objects. If a function does not need to perform an action on an about-to-be-deleted object, it can check the object’s `BeingDeleted` property before acting.

## BusyAction

cancel | {queue}

*Callback queuing*

Determines how MATLAB handles the execution of interrupting callbacks.

A *running* callback is the currently executing callback. The *interrupting* callback is the callback that tries to interrupt the *running* callback. The `BusyAction` property of the *interrupting* callback determines how MATLAB handles its execution. When the `BusyAction` property is set to:

- 'queue' — Puts the *interrupting* callback in a queue to be processed after the *running* callback finishes execution.
- 'cancel' — Discards the *interrupting* callback as MATLAB finishes execution.

For information about how the `Interruptible` property of the callback controls whether other callbacks can interrupt the *running* callback, see the `Interruptible` property description.

## `ButtonDownFcn`

string | function handle

*Button press callback function.* Executes whenever you press a mouse button while the pointer is over this object, but not over another graphics object.

See the figure's `SelectionType` property to determine if modifier keys were also pressed.

This property can be:

- A string that is a valid MATLAB expression
- The name of a MATLAB file
- A function handle

Set this property to a function handle that references the callback. The expressions execute in the MATLAB workspace.

For information on the syntax of callback functions, see [Function Handle Callbacks](#).

# Surfaceplot Properties

---

## CData

matrix

*Vertex colors.* A matrix containing values that specify the color at every point in ZData. If you set the FaceColor property to texturemap, CData does not need to be the same size as ZData. In this case, MATLAB maps CData to conform to the surfaceplot defined by ZData.

You can specify color as indexed values or true color. Indexed color data specifies a single value for each vertex. These values are either scaled to map linearly into the current colormap (see caxis) or interpreted directly as indices into the colormap, depending on the setting of the CDataMapping property. Note that any non-texture data passed as an input argument must be of type double.

True color defines an RGB value for each vertex. If the coordinate data (XData, for example) are contained in m-by-n matrices, then CData must be an m-by-n-by-3 array. The first page contains the red components, the second the green components, and the third the blue components of the colors.

## CDataMapping

{scaled} | direct

*Direct or scaled color mapping.* Determines how MATLAB interprets indexed color data used to color the surfaceplot. (If you use true color specification for CData, this property has no effect.)

- **scaled** — Transform the color data to span the portion of the colormap indicated by the axes CLim property, linearly mapping data values to colors. See the caxis reference page for more information on this mapping.
- **direct** — Use the color data as indices directly into the colormap. The color data should then be integer values ranging from 1 to length(colormap). MATLAB maps values less than

1 to the first color in the colormap, and values greater than `length(colormap)` to the last color in the colormap. Values with a decimal portion are fixed to the nearest lower integer.

**CDataMode**  
{auto} | manual

*Use automatic or user-specified color data values.* If you specify `CData`, MATLAB sets this property to `manual` and uses the `CData` values to color the surfaceplot.

If you set `CDataMode` to `auto` after having specified `CData`, MATLAB resets the color data of the surfaceplot to that defined by `ZData`, overwriting any previous values for `CData`.

**CDataSource**  
string (MATLAB variable)

*Link CData to MATLAB variable.* Set this property to a MATLAB variable that is evaluated in the base workspace to generate the `CData`.

MATLAB reevaluates this property only when you set it. Therefore, a change to workspace variables appearing in an expression does not change `CData`.

You can use the `refreshdata` function to force an update of the object's data. `refreshdata` also enables you to specify that the data source variable be evaluated in the workspace of a function from which you call `refreshdata`. See the `refreshdata` reference page for more information.

# Surfaceplot Properties

---

---

**Note** If you change one data source property to a variable that contains data of a different dimension, you might cause the function to generate a warning and not render the graph until you have changed all data source properties to appropriate values.

---

## Children

matrix of handles

Always the empty matrix; surfaceplot objects have no children.

## Clipping

{on} | off

*Clipping to axes rectangle.* When Clipping is on, MATLAB does not display any portion of the surfaceplot that is outside the axes rectangle.

## CreateFcn

function handle | cell array containing function handle and additional arguments | string (not recommended)

*Callback function executed during object creation.* Defines a callback that executes when MATLAB creates an object. The default is an empty array.

You must specify the callback during the creation of the object. For example:

```
graphicfcn(y, 'CreateFcn', @CallbackFcn)
```

where @*CallbackFcn* is a function handle that references the callback function and *graphicfcn* is the plotting function which creates this object.



MATLAB executes this routine after setting all other object properties. Setting this property on an existing object has no effect.

The handle of the object whose `CreateFcn` is being executed is accessible only through the root `CallbackObject` property, which you can query using `gcbo`.

For information on the syntax of callback functions, see [Function Handle Callbacks](#).

## `DeleteFcn`

function handle | cell array containing function handle and additional arguments | string (not recommended)

*Callback executed during object deletion.* Executes when this object is deleted (for example, this might happen when you issue a `delete` command on the object, its parent axes, or the figure containing it). MATLAB executes the callback before destroying the object's properties so the callback routine can query these values. The default is an empty array.

The handle of the object whose `DeleteFcn` is being executed is accessible only through the root `CallbackObject` property, which can be queried using `gcbo`.

For information on the syntax of callback functions, see [Function Handle Callbacks](#).

See the `BeingDeleted` property for related information.

## `DiffuseStrength`

scalar  $\geq 0$  and  $\leq 1$

*Intensity of diffuse light.* Sets the intensity of the diffuse component of the light falling on the surface. Diffuse light comes from light objects in the axes. Default value is 0.6.

# Surfaceplot Properties

---

You can also set the intensity of the ambient and specular components of the light on the object. See the `AmbientStrength` and `SpecularStrength` properties.

`DisplayName`  
string

*String used by legend.* The `legend` function uses the `DisplayName` property to label the surfaceplot object in the legend. The default is an empty string.

- If you specify string arguments with the `legend` function, MATLAB set `DisplayName` to the corresponding string and uses that string for the legend.
- If `DisplayName` is empty, `legend` creates a string of the form, `['data' n]`, where `n` is the number assigned to the object based on its location in the list of legend entries. However, `legend` does not set `DisplayName` to this string.
- If you edit the string directly in an existing legend, MATLAB set `DisplayName` to the edited string.
- If you specify a string for the `DisplayName` property and create the legend using the figure toolbar, then MATLAB uses the string defined by `DisplayName`.
- To add a legend programmatically that uses the `DisplayName` string, call `legend` with the `toggle` or `show` option.

See “Control Legend Content” for more information and examples.

`EdgeAlpha`  
{scalar = 1} | flat | interp

*Transparency of the patch and surface edges.*

- scalar — A single non-`NaN` scalar value between 0 and 1 that controls the transparency of all the edges of the object. 1 (the default) means fully opaque and 0 means completely transparent.

- `flat` — The alpha data (`AlphaData`) value for the first vertex of the face determines the transparency of the edges.
- `interp` — Linear interpolation of the alpha data (`AlphaData`) values at each vertex determines the transparency of the edge.

Note that you must specify `AlphaData` as a matrix equal in size to `ZData` to use `flat` or `interp` `EdgeAlpha`.

Note that you must specify `AlphaData` as a matrix equal in size to `ZData` to use `flat` or `interp` `EdgeAlpha`.

## `EdgeColor`

`{ColorSpec} | none | flat | interp`

*Color of the surfaceplot edge.* This property determines how MATLAB colors the edges of the individual faces that make up the surface:

- `ColorSpec` — A three-element RGB vector or one of the MATLAB predefined names, specifying a single color for edges. The default `EdgeColor` is black. See `ColorSpec` for more information on specifying color.
- `none` — Edges are not drawn.
- `flat` — The `CData` value of the first vertex for a face determines the color of each edge.

# Surfaceplot Properties

---

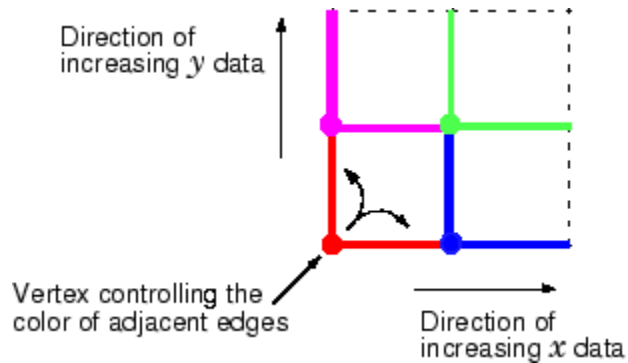

- `interp` — Linear interpolation of the CData values at the face vertices determines the edge color.

## EdgeLighting

{none} | flat | gouraud | phong

*Algorithm used for lighting calculations.* Selects the algorithm used to calculate the effect of light objects on surfaceplot edges.

- `none` — Lights do not affect the edges of this object.
- `flat` — The effect of light objects is uniform across each edge of the surfaceplot.
- `gouraud` — The effect of light objects is calculated at the vertices and then linearly interpolated across the edge lines.
- `phong` — The effect of light objects is determined by interpolating the vertex normals across each edge line and calculating the reflectance at each pixel. Phong lighting generally produces better results than Gouraud lighting, but takes longer to render.

## EraseMode

{normal} | none | xor | background

*Erase mode.* Controls the technique MATLAB uses to draw and erase objects. Use alternative erase modes for creating animated sequences, where control of the way individual objects are redrawn is necessary to improve performance and obtain the desired effect.

- **normal** — Redraw the affected region of the display, performing the three-dimensional analysis necessary to correctly render all objects. This mode produces the most accurate picture, but is the slowest. The other modes are faster, but do not perform a complete redraw and are therefore less accurate.
- **none** — Do not erase the object when it is moved or destroyed. While the object is still visible on the screen after erasing with `EraseMode none`, you cannot print it because MATLAB stores no information about its former location.
- **xor** — Draw and erase the object by performing an exclusive OR (XOR) with the color of the screen beneath it. This mode does not damage the color of the objects beneath it. However, the object's color depends on the color of whatever is beneath it on the display.
- **background** — Erase the object by redrawing it in the axes background `Color`, or the figure background `Color` if the axes `Color` property is `none`. This damages objects that are behind the erased object, but properly colors the erased object.

Set the axes background color with the axes `Color` property. Set the figure background color with the figure `Color` property.

## Printing with Nonnormal Erase Modes

MATLAB always prints figures as if the `EraseMode` of all objects is `normal`. This means graphics objects created with `EraseMode` set to `none`, `xor`, or `background` can look different on screen than on paper. On screen, MATLAB mathematically combines layers of colors (for example, performing an XOR on a pixel color with that of the pixel behind it) and ignore three-dimensional sorting

# Surfaceplot Properties

---

to obtain greater rendering speed. However, these techniques are not applied to the printed output.

You can use the `getframe` command or other screen capture applications to create an image of a figure containing nonnormal mode objects.

## FaceAlpha

`{scalar = 1} | flat | interp | texturemap`

*Transparency of the surfaceplot faces.* This property can be any of the following:

- `scalar` — A single non-NaN scalar value between 0 and 1 that controls the transparency of all the faces of the object. 1 (the default) means fully opaque and 0 means completely transparent (invisible).
- `flat` — The values of the alpha data (`AlphaData`) determine the transparency for each face. The alpha data at the first vertex determine the transparency of the entire face.
- `interp` — Bilinear interpolation of the alpha data (`AlphaData`) at each vertex determines the transparency of each face.
- `texturemap` — Use transparency for the texture map.

Note that you must specify `AlphaData` as a matrix equal in size to `ZData` to use `flat` or `interp` `FaceAlpha`.

## FaceColor

`ColorSpec | none | {flat} | interp`

*Color of the surfaceplot face.* This property can be any of the following:

- `ColorSpec` — A three-element RGB vector or one of the MATLAB predefined names, specifying a single color for faces. See `ColorSpec` for more information on specifying color.

- `none` — Do not draw faces. Note that edges are drawn independently of faces.
- `flat` — The values of `CData` determine the color for each face of the surface. The color data at the first vertex determine the color of the entire face.
- `interp` — Bilinear interpolation of the values at each vertex (the `CData`) determines the coloring of each face.
- `texturemap` — Texture map the `CData` to the surface. MATLAB transforms the color data so that it conforms to the surface. (See the texture mapping example for `surface`.)

## FaceLighting

`none` | `{flat}` | `gouraud` | `phong`

*Algorithm used for lighting calculations.* This property selects the algorithm used to calculate the effect of light objects on the surface. Choices are

- `none` — Lights do not affect the faces of this object.
- `flat` — The effect of light objects is uniform across the faces of the surface. Select this choice to view faceted objects.
- `gouraud` — The effect of light objects is calculated at the vertices and then linearly interpolated across the faces. Select this choice to view curved surfaces.
- `phong` — The effect of light objects is determined by interpolating the vertex normals across each face and calculating the reflectance at each pixel. Select this choice to view curved surfaces. Phong lighting generally produces better results than Gouraud lighting, but takes longer to render.

## HandleVisibility

`{on}` | `callback` | `off`

*Control access to object's handle.* Determines when an object's handle is visible in its parent's list of children. `HandleVisibility`

# Surfaceplot Properties

---

is useful for preventing command-line users from accidentally accessing objects that you need to protect for some reason.

- `on` — Handles are always visible.
- `callback` — Handles are visible from within callback routines or functions invoked by callback routines, but not from within functions invoked from the command line. This provides a means to protect GUIs from command-line users, while allowing callback routines to have access to object handles.
- `off` — Handles are invisible at all times. Use this option when a callback invokes a function that could damage the GUI (such as evaluating a user-typed string). This option temporarily hides its own handles during the execution of that function.

## Functions Affected by Handle Visibility

When a handle is not visible in its parent's list of children, it cannot be returned by functions that obtain handles by searching the object hierarchy or querying handle properties. This includes `get`, `findobj`, `gca`, `gcf`, `gco`, `newplot`, `cla`, `clf`, and `close`.

## Properties Affected by Handle Visibility

When a handle's visibility is restricted using `callback` or `off`, the object's handle does not appear in its parent's `Children` property, figures do not appear in the root's `CurrentFigure` property, objects do not appear in the root's `CallbackObject` property or in the figure's `CurrentObject` property, and axes do not appear in their parent's `CurrentAxes` property.

## Overriding Handle Visibility

You can set the root `ShowHiddenHandles` property to `on` to make all handles visible regardless of their `HandleVisibility` settings. This does not affect the values of the `HandleVisibility` properties. See also `findall`.



## Handle Validity

Hidden handles are still valid. If you know an object's handle, you can `set` and `get` its properties and pass it to any function that operates on handles.

---

**Note** If you change one data source property to a variable that contains data of a different dimension, you might cause the function to generate a warning and not render the graph until you have changed all data source properties to appropriate values.

---

## HitTest

{on} | off

*Selectable by mouse click.* Determines whether this object can become the current object (as returned by the `gco` command and the figure `CurrentObject` property) as a result of a mouse click on the surface. If `HitTest` is `off`, clicking this object selects the object below it (which is usually the axes containing it).

## Interruptible

off | {on}

*Callback routine interruption*

Controls whether MATLAB can interrupt an object's callback function when subsequent callbacks attempt to interrupt it.

For Graphics objects, the `Interruptible` property affects only the callbacks for the `ButtonDownFcn` property. A *running* callback is the currently executing callback. The *interrupting* callback is the callback that tries to interrupt the *running* callback. MATLAB handles both the callbacks based on the `Interruptible` property of the object of the *running* callback.

# Surfaceplot Properties

---

When the `Interruptible` property is set to:

- 'off', MATLAB finishes execution of the *running* callback without any interruptions
- 'on', these conditions apply:
  - If there is a `drawnow`, `figure`, `getframe`, `waitfor`, or `pause` command in the *running* callback, then MATLAB executes the *interrupting* callbacks which are already in the queue and returns to finish execution of the current callback.
  - If one of the above functions is not in the *running* callback, then MATLAB finishes execution of the current callback without any interruption.

`BusyAction` property of the object of interrupting callback determines whether the callback should be ignored or should be put in the queue.

Setting `Interruptible` property to on (default), allows a callback from other graphics objects to interrupt callback functions originating from this object.

---

**Note** MATLAB does not save the state of properties or the display when an interruption occurs. For example, the handle returned by the `gca` or `gcf` command may be changed as another callback is executed.

---

After the function that interrupts a callback completes, the callback resumes execution where it halted when interrupted. For more information, see “Control Callback Execution and Interruption”.

`LineStyle`  
{-} | -- | : | -. | none

*Line style of surfaceplot object.*

## Line Style Specifiers Table

Specifier	Line Style
'-'	Solid line (default)
'--'	Dashed line
':'	Dotted line
'-.'	Dash-dot line
'none'	No line

Use `LineStyle none` when you want to place a marker at each point but do not want the points connected with a line (see the `Marker` property).

`LineWidth`  
size in points

*Width of linear objects and edges of filled areas. Specify in points. 1 point =  $1/72$  inch. The default is 0.5 points.*

`Marker`  
character (see table)

*Marker symbol.* Specifies marks that display at data points. You can set values for the `Marker` property independently from the `LineStyle` property. For a list of supported marker symbols, see the following table.

## Marker Specifiers Table

Specifier	Marker Type
'+'	Plus sign
'o'	Circle

# Surfaceplot Properties

---

Specifier	Marker Type
'*'	Asterisk
'.'	Point
'x'	Cross
'square' or 's'	Square
'diamond' or 'd'	Diamond
'^'	Upward-pointing triangle
'v'	Downward-pointing triangle
'>'	Right-pointing triangle
'<'	Left-pointing triangle
'pentagram' or 'p'	Five-pointed star (pentagram)
'hexagram' or 'h' ' ' '	Six-pointed star (hexagram)
'none'	No marker (default)

## MarkerEdgeColor

none | {auto} | flat | ColorSpec

*Marker edge color.* The color of the marker or the edge color for filled markers (circle, square, diamond, pentagram, hexagram, and the four triangles).

- none — Specifies no color, which makes nonfilled markers invisible.
- auto — Uses same color as the EdgeColor property.
- flat — Uses the CData value of the vertex to determine the color of the marker edge.
- ColorSpec — Defines color to use.

## MarkerFaceColor

{none} | auto | flat | ColorSpec

*Marker face color.* The fill color for markers that are closed shapes (circle, square, diamond, pentagram, hexagram, and the four triangles).

- `none` — Makes the interior of the marker transparent, allowing the background to show through.
- `auto` — Uses the axes `Color` for the marker face color.
- `flat` — Uses the `CData` value of the vertex to determine the color of the face.
- `ColorSpec` — Defines a single color to use for all markers on the surfaceplot.

`MarkerSize`  
scalar

*Marker size.* Size of the marker in points. The default value is 6.

---

**Note** MATLAB draws the point marker (specified by the `'.'` symbol) at one-third the specified size.

---

`MeshStyle`  
{both} | row | column

*Row and column lines.* Specifies whether to draw all edge lines or just row or column edge lines.

- `both` — Draws edges for both rows and columns.
- `row` — Draws row edges only.
- `column` — Draws column edges only.

`NormalMode`  
{auto} | manual

*MATLAB generated or user-specified normal vectors.*

# Surfaceplot Properties

---

- `auto` — MATLAB calculates vertex normals based on the coordinate data
- `manual` — If you specify your own vertex normals, MATLAB sets this property to `manual` and does not generate its own data.

See also the `VertexNormals` property.

## Parent

handle of parent axes, `hggroup`, or `hgtransform`

*Parent of object.* Handle of the object's parent. The parent is normally the axes, `hggroup`, or `hgtransform` object that contains the object.

## Selected

`on` | `{off}`

*Object selection state.* When you set this property to `on`, MATLAB displays selection handles at the corners and midpoints if the `SelectionHighlight` property is also `on` (the default). You can, for example, define the `ButtonDownFcn` callback to set this property to `on`, thereby indicating that this particular object is selected. This property is also set to `on` when an object is manually selected in plot edit mode.

## SelectionHighlight

`{on}` | `off`

*Selected objects highlighted.*

- `on` — MATLAB indicates the selected state by drawing a dashed bounding box around the surface.
- `off` — MATLAB does not draw the bounding box except when in plot edit mode and objects are selected manually.

## SpecularColorReflectance

scalar in the range 0 to 1

*Color of specularly-reflected light.* When this property is 0, the color of the specularly-reflected light depends on both the color of the object from which it reflects and the color of the light source. When set to 1, the color of the specularly-reflected light depends only on the color of the light source (that is, the light object `Color` property). The proportions vary linearly for values in between.

**SpecularExponent**

scalar  $\geq 1$

*Harshness of specular reflection.* Controls the size of the specular spot. Most materials have exponents in the range of 5 to 20.

**SpecularStrength**

scalar  $\geq 0$  and  $\leq 1$

*Intensity of specular light.* Sets the intensity of the specular component of the light falling on the surfaceplot. Specular light comes from light objects in the axes.

You can also set the intensity of the ambient and diffuse components of the light on the surfaceplot object. See the `AmbientStrength` and `DiffuseStrength` properties. Also see the `material` function.

**Tag**

string

*User-specified object label.* Provides a means to identify graphics objects with a user-specified label. The default is an empty string.

Use the `Tag` property and the `findobj` function to manipulate specific objects within a plotting hierarchy.

For example, create an `areaseries` object and set the `Tag` property.

```
t = area(Y, 'Tag', 'area1')
```

# Surfaceplot Properties

---

When you want to access objects of a given type, use `findobj` to find the object's handle. The following statement changes the `FaceColor` property of the object whose `Tag` is `area1`.

```
set(findobj('Tag','area1'),'FaceColor','red')
```

## Type

string (read only)

*Class of the graphics object.* String that identifies the class of the graphics object. Use this property to find all objects of a given type within a plotting hierarchy. For surfaceplot objects, `Type` is always the string `'surface'`.

## UIContextMenu

handle of `uicontextmenu` object

*Associate context menu with object.* Handle of a `uicontextmenu` object created in the object's parent figure. Use the `uicontextmenu` function to create the context menu. MATLAB displays the context menu whenever you right-click over the object. The default value is an empty array.

## UserData

array

*User-specified data.* Data you want to associate with this object (including cell arrays and structures). The default value is an empty array. MATLAB does not use this data, but you can access it using the `set` and `get` commands.

## VertexNormals

vector | matrix

*Surfaceplot normal vectors.* Contains the vertex normals for the surfaceplot. MATLAB generates this data to perform lighting calculations. You can supply your own vertex normal data, even if it does not match the coordinate data. This can be useful to produce interesting lighting effects.



## Visible

{on} | off

*Visibility of object and its children.*

- on — Object and all children of the object are visible unless the child object's Visible property is off.
- off — Object not displayed. However, the object still exists and you can set and query its properties.

## XData

vector | matrix

*X-coordinates.* The  $x$ -position of the surfaceplot data points. If you specify a row vector, MATLAB replicates the row internally until it has the same number of columns as ZData.

## XDataMode

{auto} | manual

*Use automatic or user-specified  $x$ -axis values.* If you specify XData (by setting the XData property or specifying the X input argument), MATLAB sets this property to manual and uses the specified values to label the  $x$ -axis.

If you set XDataMode to auto after specifying XData, MATLAB resets the  $x$ -axis ticks to `1:size(YData,1)` or to the column indices of the ZData, overwriting any previous values for XData.

## XDataSource

MATLAB variable, as a string

*Link XData to MATLAB variable.* Set this property to a MATLAB variable that is evaluated in the base workspace to generate the XData. The default value is an empty array.

```
set(h, 'XDataSource', 'xdatablvariable')
```

# Surfaceplot Properties

---

MATLAB requires a call to `refreshdata` when you set this property. Changing workspace variables used as an object's `XDataSource` does not change the object's `XData` values, but you can use `refreshdata` to force an update of the object's data. `refreshdata` also lets you specify that the data source variable be evaluated in the workspace of a function from which you call `refreshdata`.

---

**Note** If you change one data source property to a variable that contains data of a different dimension, you might cause the function to generate a warning and not render the graph until you have changed all data source properties to appropriate values.

---

## YData

vector | matrix

*Y-coordinates.* The *y*-position of the surfaceplot data points. If you specify a row vector, MATLAB replicates the row internally until it has the same number of rows as `ZData`.

## YDataMode

{auto} | manual

*Use automatic or user-specified y-axis values.* If you specify `XData`, MATLAB sets this property to `manual`.

If you set `YDataMode` to `auto` after having specified `YData`, MATLAB resets the *y*-axis ticks and *y*-tick labels to the row indices of the `ZData`, overwriting any previous values for `YData`.

## YDataSource

MATLAB variable, as a string

*Link YData to MATLAB variable.* Set this property to a MATLAB variable that is evaluated in the base workspace to generate the `YData`. The default value is an empty array.

```
set(h, 'YDataSource', 'Ydatavariablename')
```

MATLAB requires a call to `refreshdata` when you set this property. Changing workspace variables used as an object's `YDataSource` does not change the object's `YData` values, but you can use `refreshdata` to force an update of the object's data. `refreshdata` also lets you specify that the data source variable be evaluated in the workspace of a function from which you call `refreshdata`.

---

**Note** If you change one data source property to a variable that contains data of a different dimension, you might cause the function to generate a warning and not render the graph until you have changed all data source properties to appropriate values.

---

## ZData

matrix

*Z-coordinates.* The *z*-position of the surfaceplot data points. See the Description section for more information.

## ZDataSource

MATLAB variable, as a string

*Link ZData to MATLAB variable.* Set this property to a MATLAB variable that is evaluated in the base workspace to generate the `ZData`. The default value is an empty array.

```
set(h, 'ZDataSource', 'zdatavariablename')
```

MATLAB requires a call to `refreshdata` when you set this property. Changing workspace variables used as an object's `ZDataSource` does not change the object's `ZData` values, but you can use `refreshdata` to force an update of the object's data. `refreshdata` also lets you specify that the data source variable

# Surfaceplot Properties

---

be evaluated in the workspace of a function from which you call `refreshdata`.

---

**Note** If you change one data source property to a variable that contains data of a different dimension, you might cause the function to generate a warning and not render the graph until you have changed all data source properties to appropriate values.

---

**Purpose**

Surface plot with colormap-based lighting

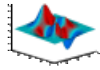
**Syntax**

```
surf1(Z)
surf1(...,'light')
surf1(...,s)
surf1(X,Y,Z,s,k)
h = surf1(...)
```

**Description**

The `surf1` function displays a shaded surface based on a combination of ambient, diffuse, and specular lighting models.

`surf1(Z)` and `surf1(X,Y,Z)` create three-dimensional shaded surfaces using the default direction for the light source and the default lighting coefficients for the shading model. `X`, `Y`, and `Z` are vectors or matrices that define the  $x$ ,  $y$ , and  $z$  components of a surface.

`surf1(...,'light')` produces a colored, lighted surface using a MATLAB light object. This produces results different from the default lighting method, `surf1(...,'cdata')`, which changes the color data for the surface to be the reflectance of the surface.

`surf1(...,s)` specifies the direction of the light source. `s` is a two- or three-element vector that specifies the direction from a surface to a light source. `s = [sx sy sz]` or `s = [azimuth elevation]`. The default `s` is 45° counterclockwise from the current view direction.

`surf1(X,Y,Z,s,k)` specifies the reflectance constant. `k` is a four-element vector defining the relative contributions of ambient light, diffuse reflection, specular reflection, and the specular shine coefficient. `k = [ka kd ks shine]` and defaults to `[.55, .6, .4, 10]`.

`h = surf1(...)` returns a handle to a surface graphics object. If you specify the 'light' option, `h` contains the handle to the surface and the light objects.

## Tips

surf1 does not accept complex inputs.

For smoother color transitions, use colormaps that have linear intensity variations (e.g., gray, copper, bone, pink).

The ordering of points in the X, Y, and Z matrices defines the inside and outside of parametric surfaces. If you want the opposite side of the surface to reflect the light source, use `surf1(X',Y',Z')`. Because of the way surface normal vectors are computed, surf1 requires matrices that are at least 3-by-3.

## Examples

### Create Surface Plot With Colormap-Based Lighting

Create a surface plot of the `peaks` function using colormap-based lighting. Set the shading to `interp` to interpolate the colors across lines and faces.

```
[x,y] = meshgrid(-3:1/8:3);
z = peaks(x,y);
surf1(x,y,z);
shading interp
```

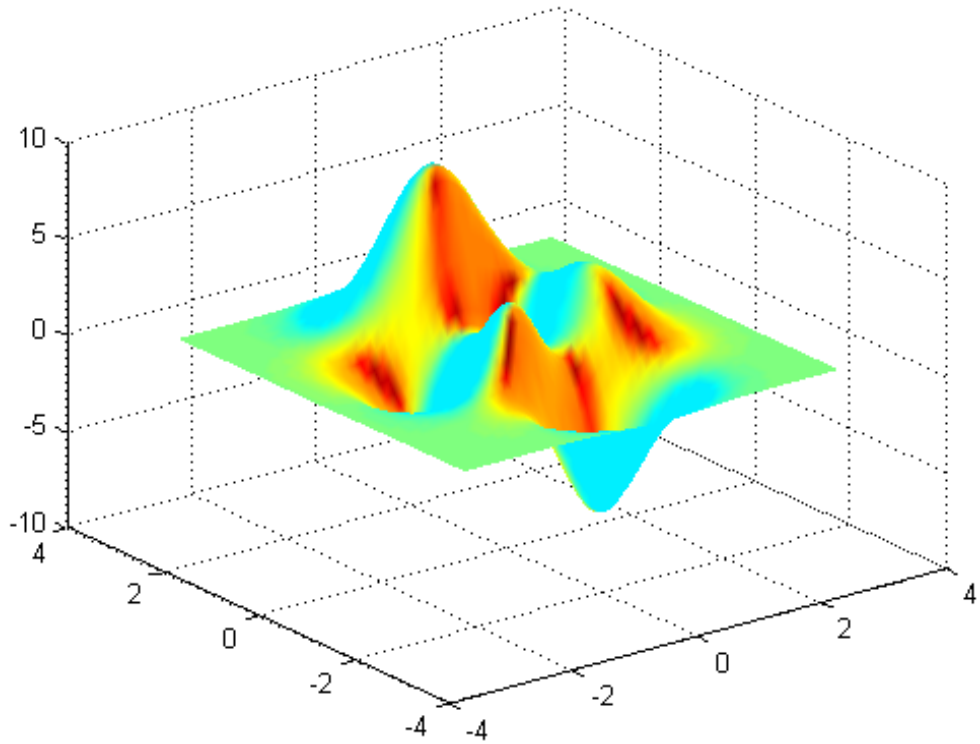

**See Also** [colormap](#) | [shading](#) | [light](#)

# surfnorm

---

**Purpose** Compute and display 3-D surface normals

**Syntax**

```
surfnorm(Z)
surfnorm(X,Y,Z)
surfnorm(axes_handle, ___)
surfnorm(___,Name,Value)
[Nx,Ny,Nz] = surfnorm(___)
```

**Description**

`surfnorm(Z)` plots a surface of the matrix `Z` with `surf` and displays its surface normals as radiating vectors.

`surfnorm(X,Y,Z)` plots a surface and its surface normals from the vectors or matrices `X`, `Y`, and matrix `Z`. `X`, `Y`, and `Z` must be the same size.

`surfnorm(axes_handle, ___)` plots into `axes_handle` instead of `gca` and it can include any of the input arguments in previous syntaxes.

`surfnorm( ___,Name,Value)` can be used to set the value of the specified Surface Properties.

`[Nx,Ny,Nz] = surfnorm( ___)` returns the components of the 3-D surface normals for the surface without plotting the surface or surface normals.

**Tips**

- `surfnorm` does not accept complex inputs.
- Reverse the direction of the normals by calling `surfnorm` with transposed arguments:  

```
surfnorm(X',Y',Z')
```
- The surface normals represent conditions at vertices and are not normalized. Normals for surface elements that face away from the viewer do not display.
- `surf1` uses `surfnorm` to compute surface normals when calculating the reflectance of a surface.



**Input Arguments****Z**

2-D array of real numbers representing a surface

**X**

2-D array of real numbers that defines the  $x$  component of the surface grid

**Y**

2-D array of real numbers that defines the  $y$  component of the surface grid

**axes\_handle**

Handle to the target axes in which to plot the surface

If you do not specify `axes_handle`, MATLAB uses current axes.

**Name,Value**

Specify optional comma-separated pairs of Name,Value arguments, where Name is the argument name and Value is the corresponding value. Name must appear inside single quotes ( ' '). You can specify several name and value pair arguments in any order as Name1,Value1,...,NameN,ValueN.

Property names and values of the surface object

See `Surface Properties` for description of property names and values.

**Output Arguments****[Nx,Ny,Nz]**

$x$ ,  $y$ , and  $z$  components of the three-dimensional surface normals for the surface

**Definitions****Surface Normal**

An imaginary line perpendicular to a flat surface or perpendicular to the tangent plane at a point on a non-flat surface

## Examples

### Display 3-D Surface Normals for Cone Plot

Compute and plot the normal vectors for a truncated cone. Set the axis limits using the axis function.

```
[x,y,z] = cylinder(1:10);
figure
surfnorm(x,y,z)
axis([-12 12 -12 12 -0.1 1])
```

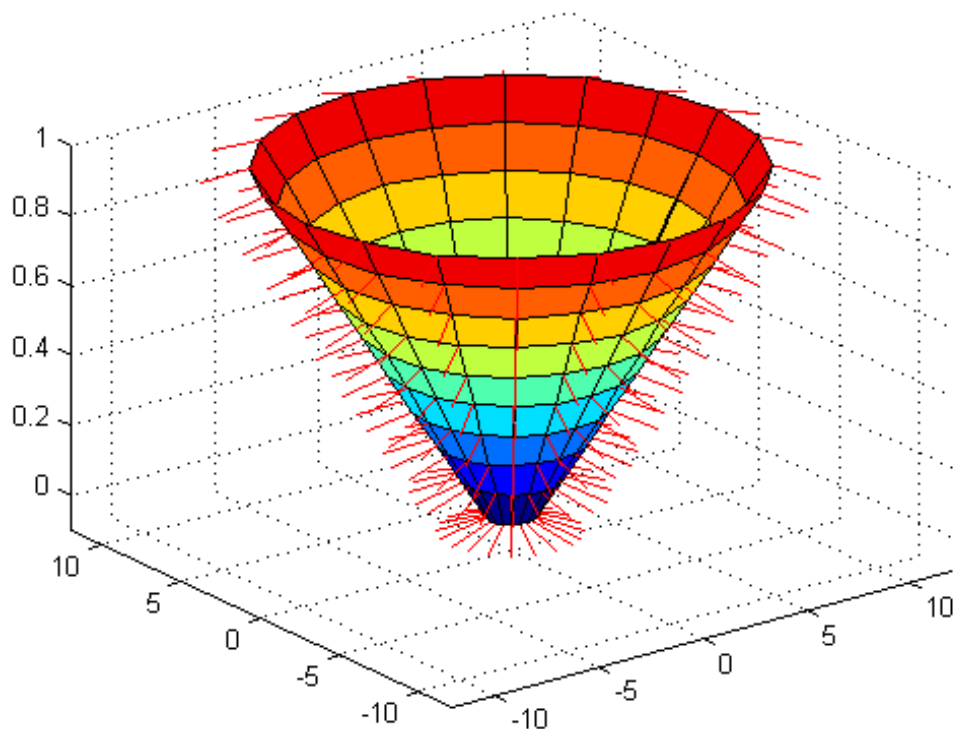

### **Use Computed Surface Normals for Lighting**

Compute the normal vectors of an expression representing a surface.

```
[nx, ny, nz] = surfnorm(peaks);
```

Assign these normals to the `VertexNormals` property which MATLAB® uses to calculate the surface lighting. Set the lighting algorithm to `gouraud` and add a light using `camlight`.

```
b = reshape([nx ny nz], 49,49,3);
figure
surf(ones(49),'VertexNormals',b,'EdgeColor','none');
lighting gouraud
camlight
```

# surfnorm

---

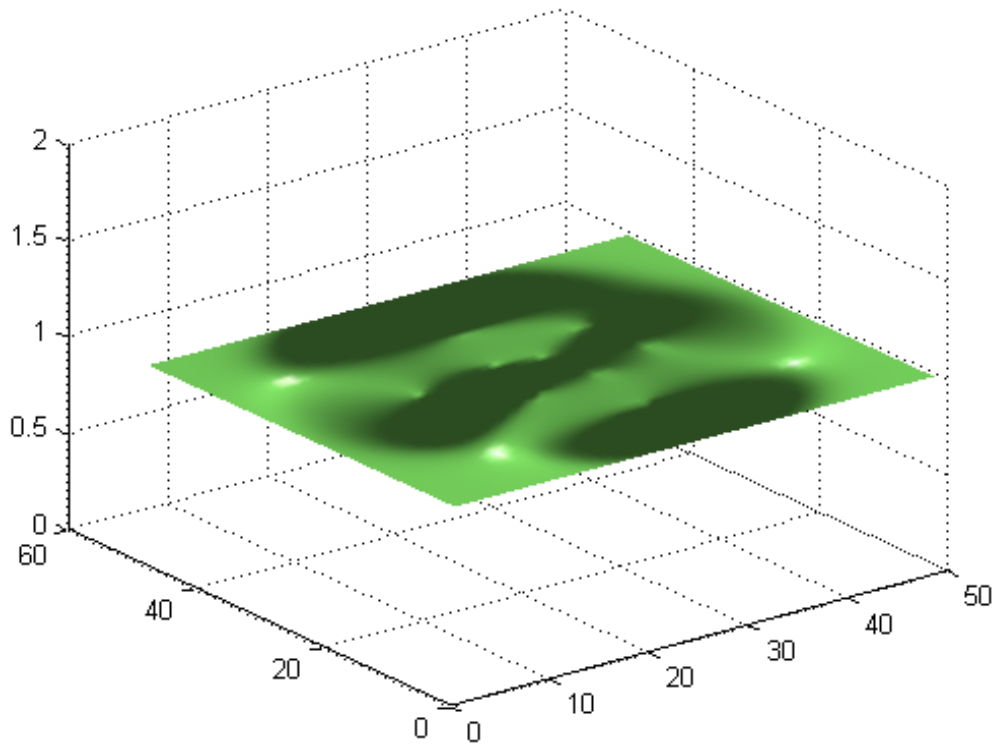

## Algorithms

After performing a bicubic fit of the data in the  $x$ ,  $y$ , and  $z$  directions, diagonal vectors are computed and crossed to form the normal at each vertex.

## See Also

`surf` | `quiver3` | `surface` | `isonormals` | `surf1`

**Purpose** Singular value decomposition

**Syntax**

```
s = svd(X)
[U,S,V] = svd(X)
[U,S,V] = svd(X,0)
[U,S,V] = svd(X,'econ')
```

**Description** The svd command computes the matrix singular value decomposition. `s = svd(X)` returns a vector of singular values.

`[U,S,V] = svd(X)` produces a diagonal matrix `S` of the same dimension as `X`, with nonnegative diagonal elements in decreasing order, and unitary matrices `U` and `V` so that  $X = U*S*V'$ .

`[U,S,V] = svd(X,0)` produces the “economy size” decomposition. If `X` is `m`-by-`n` with `m > n`, then `svd` computes only the first `n` columns of `U` and `S` is `n`-by-`n`.

`[U,S,V] = svd(X,'econ')` also produces the “economy size” decomposition. If `X` is `m`-by-`n` with `m >= n`, it is equivalent to `svd(X,0)`. For `m < n`, only the first `m` columns of `V` are computed and `S` is `m`-by-`m`.

**Examples** For the matrix

```
X =
 1 2
 3 4
 5 6
 7 8
```

the statement

```
[U,S,V] = svd(X)
```

produces

```
U =
-0.1525 -0.8226 -0.3945 -0.3800
```

# svd

---

```
-0.3499 -0.4214 0.2428 0.8007
-0.5474 -0.0201 0.6979 -0.4614
-0.7448 0.3812 -0.5462 0.0407
```

```
S =
 14.2691 0
 0 0.6268
 0 0
 0 0
```

```
V =
 -0.6414 0.7672
 -0.7672 -0.6414
```

The economy size decomposition generated by

```
[U,S,V] = svd(X,0)
```

produces

```
U =
 -0.1525 -0.8226
 -0.3499 -0.4214
 -0.5474 -0.0201
 -0.7448 0.3812
```

```
S =
 14.2691 0
 0 0.6268
```

```
V =
 -0.6414 0.7672
 -0.7672 -0.6414
```

## Diagnostics

If the limit of 75 QR step iterations is exhausted while seeking a singular value, this message appears:

```
Solution will not converge.
```

**Purpose** Find singular values and vectors

**Syntax**

```
s = svds(A)
s = svds(A,k)
s = svds(A,k,sigma)
s = svds(A,k,'L')
s = svds(A,k,sigma,options)
[U,S,V] = svds(A,...)
[U,S,V,flag] = svds(A,...)
```

**Description** `s = svds(A)` computes the six largest singular values and associated singular vectors of matrix A. If A is m-by-n, `svds(A)` manipulates eigenvalues and vectors returned by `eigs(B)`, where `B = [sparse(m,m) A; A' sparse(n,n)]`, to find a few singular values and vectors of A. The positive eigenvalues of the symmetric matrix B are the same as the singular values of A.

`s = svds(A,k)` computes the k largest singular values and associated singular vectors of matrix A.

`s = svds(A,k,sigma)` computes the k singular values closest to the scalar shift sigma. For example, `s = svds(A,k,0)` computes the k smallest singular values and associated singular vectors.

`s = svds(A,k,'L')` computes the k largest singular values (the default).

`s = svds(A,k,sigma,options)` sets some parameters (see `eigs`):

### Option Structure Fields and Descriptions

Field name	Parameter	Default
<code>options.tol</code>	Convergence tolerance: $\text{norm}(AV-US,1) \leq \text{tol} * \text{norm}(A,1)$	1e-10
<code>options.maxit</code>	Maximum number of iterations	300
<code>options.disp</code>	Number of values displayed each iteration	0

`svds` checks the accuracy of the computed singular vectors. If the vectors are not accurate enough, then `svds` returns fewer singular values than requested. To obtain the requested number of singular values, try decreasing the error tolerance in the options structure.

`[U,S,V] = svds(A,...)` returns three output arguments, and if `A` is `m`-by-`n`:

- `U` is `m`-by-`k` with orthonormal columns
- `S` is `k`-by-`k` diagonal
- `V` is `n`-by-`k` with orthonormal columns
- `U*S*V'` is the closest rank `k` approximation to `A`

`[U,S,V,flag] = svds(A,...)` returns a convergence flag. If `eigs` converged, then `norm(A*V-U*S,1) <= tol*norm(A,1)` and `flag` is 0. If `eigs` did not converge, then `flag` is 1.

---

**Note** `svds` is best used to find a few singular values of a large, sparse matrix. To find all the singular values of such a matrix, `svd(full(A))` will usually perform better than `svds(A,min(size(A)))`.

---

## Algorithms

`svds(A,k)` uses `eigs` to find the `k` largest magnitude eigenvalues and corresponding eigenvectors of `B = [0 A; A' 0]`.

`svds(A,k,0)` uses `eigs` to find the `2k` smallest magnitude eigenvalues and corresponding eigenvectors of `B = [0 A; A' 0]`, and then selects the `k` positive eigenvalues and their eigenvectors.

## Examples

### Singular Values of Sparse Matrix

`west0479` is a real 479-by-479 sparse matrix. `svd` calculates all 479 singular values. `svds` picks out only the largest and smallest singular values.

```
load west0479
s = svd(full(west0479));
```



```
s1 = svds(west0479,4);
ss = svds(west0479,6,0);
```

Warning: NORMEST did not converge for 100 iterations with tolerance 1e-10

These plots show some of the singular values of west0479 as computed by svd and svds.

```
subplot(2,1,1)
plot(s(1:4),'ks'), hold on
plot(s1,'k+'), hold off
title('4 largest singular values of west0479')
legend('svd(A)', 'svds(A,4)')
set(gca,'XLim',[0.5 4.5])

subplot(2,1,2)
plot(s(end-5:end),'ks'), hold on
plot(ss,'k+'), hold off
title('6 smallest singular values of west0479')
legend('svd(A)', 'svds(A,6,0)')
set(gca,'XLim',[0.5 6.5])
```

# svds

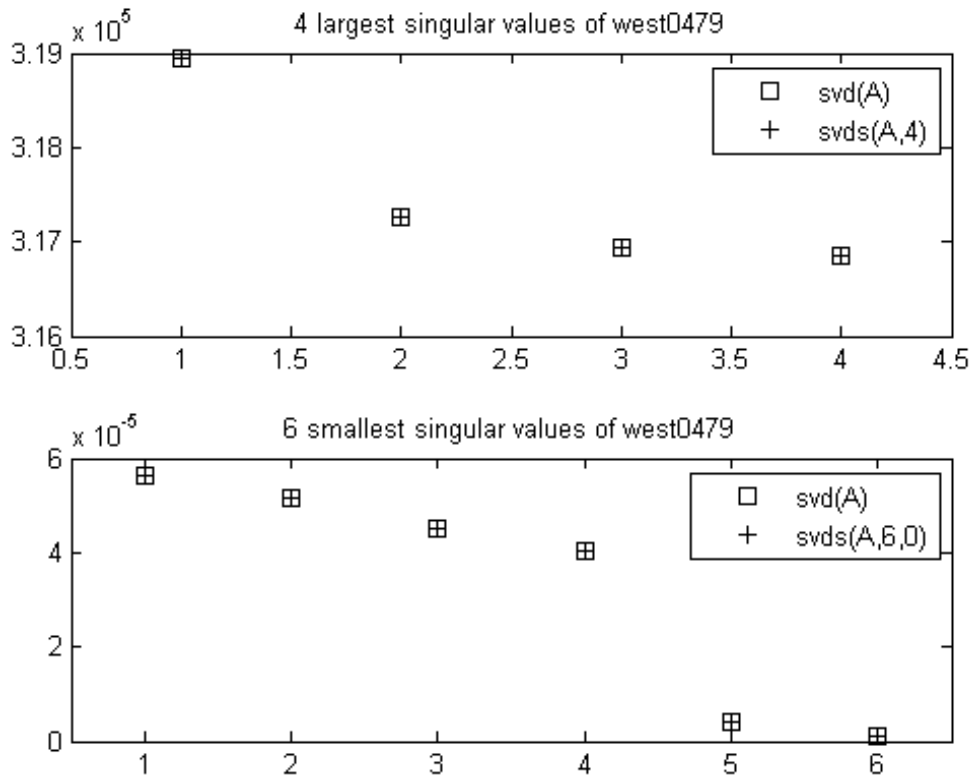

The largest singular value of west0479 can be computed a few different ways:

```
svds(west0479, 1)
max(svd(full(west0479)))
norm(full(west0479))
```

ans =

```
3.1895e+05
```

```
ans =
```

```
3.1895e+05
```

```
ans =
```

```
3.1895e+05
```

Or, to estimate the largest singular value:

```
normest(west0479)
```

```
Warning: NORMEST did not converge for 100 iterations with tolerance 1e-10
```

```
ans =
```

```
3.1854e+05
```

## See Also

[svd](#) | [eigs](#)

# swapbytes

---

**Purpose** Swap byte ordering

**Syntax** Y = swapbytes(X)

**Description** Y = swapbytes(X) reverses the byte ordering of each element in array X, converting little-endian values to big-endian (and vice versa). The input array must contain all full, noncomplex, numeric elements.

## **Examples** **Example 1**

Reverse the byte order for a scalar 32-bit value, changing hexadecimal 12345678 to 78563412:

```
A = uint32(hex2dec('12345678'));
```

```
B = dec2hex(swapbytes(A))
```

```
B =
 78563412
```

## **Example 2**

Reverse the byte order for each element of a 1-by-4 matrix:

```
X = uint16([0 1 128 65535])
```

```
X =
 0 1 128 65535
```

```
Y = swapbytes(X);
```

```
Y =
 0 256 32768 65535
```

Examining the output in hexadecimal notation shows the byte swapping:

```
format hex
```

```
X, Y
```

```
X =
 0000 0001 0080 ffff
```

```
Y =
 0000 0100 8000 ffff
```

### Example 3

Create a three-dimensional array A of 16-bit integers and then swap the bytes of each element:

```
format hex
```

```
A = uint16(magic(3) * 150);
A(:,:,2) = A * 40;
```

```
A
A(:,:,1) =
 04b0 0096 0384
 01c2 02ee 041a
 0258 0546 012c
A(:,:,2) =
 bb80 1770 8ca0
 4650 7530 a410
 5dc0 d2f0 2ee0
```

```
swapbytes(A)
ans(:,:,1) =
 b004 9600 8403
 c201 ee02 1a04
 5802 4605 2c01
ans(:,:,2) =
 80bb 7017 a08c
 5046 3075 10a4
 c05d f0d2 e02e
```

### See Also

`typecast`

# switch, case, otherwise

---

**Purpose** Switch among several cases based on expression

**Syntax**

```
switch switch_expression
 case case_expression
 statements
 case case_expression
 statements
 ...
 otherwise
 statements
end
```

**Description** A switch block conditionally executes one set of statements from several choices. Each choice is a case.

An evaluated *switch\_expression* is a scalar or string. An evaluated *case\_expression* is a scalar, a string, or a cell array of scalars or strings. The switch block tests each case until one of the cases is true. A case is true when:

- For numbers, `eq(case_expression,switch_expression)`.
- For strings, `strcmp(case_expression,switch_expression)`.
- For objects that support the `eq` function, `eq(case_expression,switch_expression)`.
- For a cell array *case\_expression*, at least one of the elements of the cell array matches *switch\_expression*, as defined above for numbers, strings, and objects.

When a case is true, MATLAB executes the corresponding statements, and then exits the switch block.

*otherwise* is optional, and executes only when no case is true.

**Tips**

- Unlike the C language switch statement, the MATLAB switch does not fall through. If the first case statement is true, the other case

statements do not execute. Do not use a `break` statement within a `switch` block.

- A *case\_expression* cannot include relational operators such as `<` or `>` to compare against the *switch\_expression*. To test for inequality, use `if-elseif` statements.
- Because MATLAB executes only one case of any `switch` statement, variables defined within one case are not available for other cases. For example, if your current workspace does not contain a variable `x`, only cases that define `x` can use it:

```
switch choice
 case 1
 x = -pi:0.01:pi;
 case 2
 % does not know anything about x
end
```

## Examples

Conditionally display different text depending on a value entered at the command line:

```
mynumber = input('Enter a number:');
```

```
switch mynumber
 case -1
 disp('negative one');
 case 0
 disp('zero');
 case 1
 disp('positive one');
 otherwise
 disp('other value');
end
```

---

Decide which plot to create based on the value of the string `plottype`:

# switch, case, otherwise

---

```
x = [12, 64, 24];
plottype = 'pie3';

switch plottype
 case 'bar'
 bar(x)
 title('Bar Graph')
 case {'pie', 'pie3'}
 pie3(x)
 title('Pie Chart')
 legend('First', 'Second', 'Third')
 otherwise
 warning('Unexpected plot type. No plot created.');
```

---

In MATLAB switch blocks, only the first matching case executes:

```
result = 52;

switch(result)
 case 52
 disp('result is 52')
 case {52, 78}
 disp('result is 52 or 78')
end
```

This code returns

```
result is 52
```

## See Also

```
end | for | while | if
```



<b>Purpose</b>	Solve Sylvester equation $AX + XB = C$ for $X$
<b>Syntax</b>	$X = \text{sylvester}(A,B,C)$
<b>Description</b>	<p><math>X = \text{sylvester}(A,B,C)</math> returns the solution, <math>X</math>, to the Sylvester equation.</p> <p>Input <math>A</math> is an <math>m</math>-by-<math>m</math> matrix, input <math>B</math> is an <math>n</math>-by-<math>n</math> matrix, and both <math>C</math> and <math>X</math> are <math>m</math>-by-<math>n</math> matrices.</p>
<b>Input Arguments</b>	<p><b>A,B,C - Input matrices</b> matrices</p> <p>Input matrices, specified as matrices. Input <math>A</math> is an <math>m</math>-by-<math>m</math> square matrix, input <math>B</math> is an <math>n</math>-by-<math>n</math> square matrix, and input <math>C</math> is an <math>m</math>-by-<math>n</math> rectangular matrix. The function returns an error if any input matrix is sparse.</p> <p><b>Data Types</b> single   double <b>Complex Number Support:</b> Yes</p>
<b>Output Arguments</b>	<p><b>X - Solution</b> matrix</p> <p>Solution, returned as a matrix of the same size as <math>C</math>. The function returns an error if the eigenvalues of <math>A</math> and <math>-B</math> are not distinct (in this case, the solution, <math>X</math>, is singular or not unique).</p>
<b>Examples</b>	<p><b>Solve Sylvester Equation with 3-by-3 Output</b></p> <p>Create the coefficient matrices <math>A</math> and <math>B</math>.</p> <pre>A = [1 -1 1; 1 1 -1; 1 1 1]; B = magic(3);</pre> <p>Define <math>C</math> as the 3-by-3 identity matrix.</p> <pre>C = eye(3);</pre>

Use the `sylvester` function to solve the Sylvester equation for these values of A, B, and C.

```
X = sylvester(A,B,C)
```

```
X =
```

```
 0.1223 -0.0725 0.0131
 -0.0806 -0.0161 0.1587
 -0.0164 0.1784 -0.1072
```

The result is a 3-by-3 matrix.

## **Solve Sylvester Equation with 4-by-2 Output**

Create a 4-by-4 coefficient matrix, A, and 2-by-2 coefficient matrix, B.

```
A = [1 0 2 3; 4 1 0 2; 0 5 5 6; 1 7 9 0];
```

```
B = [0 -1; 1 0];
```

Define C as a 4-by-2 matrix to match the corresponding sizes of A and B.

```
C = [1 0; 2 0; 0 3; 1 1]
```

```
C =
```

```
 1 0
 2 0
 0 3
 1 1
```

Use the `sylvester` function to solve the Sylvester equation for these values of A, B, and C.

```
X = sylvester(A,B,C)
```

```
X =
```

```
 0.4732 -0.3664
 -0.4006 0.3531
```

```
0.3305 -0.1142
0.0774 0.3560
```

The result is a 4-by-2 matrix.

## Definitions **Sylvester Equation**

The Sylvester equation is

$$AX + XB = C.$$

The equation has a unique solution when the eigenvalues of  $A$  and  $-B$  are distinct. In terms of the Kronecker tensor product,  $\otimes$ , the equation is

$$\left[ I \otimes A + B^T \otimes I \right] X(:) = C(:),$$

where  $I$  is the identity matrix, and  $X(:)$  and  $C(:)$  denote the matrices  $X$  and  $C$  as single column vectors.

**See Also** `ctranspose` | `kron` | `eig` | `mtimes` | `mldivide`

# symamd

---

**Purpose** Symmetric approximate minimum degree permutation

**Syntax**  
`p = symamd(S)`  
`p = symamd(S,knobs)`  
`[p,stats] = symamd(...)`

**Description** `p = symamd(S)` for a symmetric positive definite matrix `S`, returns the permutation vector `p` such that `S(p,p)` tends to have a sparser Cholesky factor than `S`. To find the ordering for `S`, `symamd` constructs a matrix `M` such that `spones(M'*M) = spones(S)`, and then computes `p = colamd(M)`. The `symamd` function may also work well for symmetric indefinite matrices.

`S` must be square; only the strictly lower triangular part is referenced.

`p = symamd(S,knobs)` where `knobs` is a scalar. If `S` is `n`-by-`n`, rows and columns with more than `knobs*n` entries are removed prior to ordering, and ordered last in the output permutation `p`. If the `knobs` parameter is not present, then `knobs = spparms('wh_frac')`.

`[p,stats] = symamd(...)` produces the optional vector `stats` that provides data about the ordering and the validity of the matrix `S`.

<code>stats(1)</code>	Number of dense or empty rows ignored by <code>symamd</code>
<code>stats(2)</code>	Number of dense or empty columns ignored by <code>symamd</code>
<code>stats(3)</code>	Number of garbage collections performed on the internal data structure used by <code>symamd</code> (roughly of size <code>8.4*nnz(tril(S,-1)) + 9n</code> integers)
<code>stats(4)</code>	0 if the matrix is valid, or 1 if invalid
<code>stats(5)</code>	Rightmost column index that is unsorted or contains duplicate entries, or 0 if no such column exists
<code>stats(6)</code>	Last seen duplicate or out-of-order row index in the column index given by <code>stats(5)</code> , or 0 if no such row index exists
<code>stats(7)</code>	Number of duplicate and out-of-order row indices

Although, MATLAB built-in functions generate valid sparse matrices, a user may construct an invalid sparse matrix using the MATLAB C or Fortran APIs and pass it to `symamd`. For this reason, `symamd` verifies that `S` is valid:

- If a row index appears two or more times in the same column, `symamd` ignores the duplicate entries, continues processing, and provides information about the duplicate entries in `stats(4:7)`.
- If row indices in a column are out of order, `symamd` sorts each column of its internal copy of the matrix `S` (but does not repair the input matrix `S`), continues processing, and provides information about the out-of-order entries in `stats(4:7)`.
- If `S` is invalid in any other way, `symamd` cannot continue. It prints an error message, and returns no output arguments (`p` or `stats`).

The ordering is followed by a symmetric elimination tree post-ordering.

## Examples

### Compare Reverse Cuthill-McKee and Minimum Degree

Here is a comparison of reverse Cuthill-McKee and minimum degree on the Bucky ball example mentioned in the `symrcm` reference page.

```
B = bucky+4*speye(60);
r = symrcm(B);
p = symamd(B);
R = B(r,r);
S = B(p,p);
subplot(2,2,1), spy(R,4), title('B(r,r)')
subplot(2,2,2), spy(S,4), title('B(s,s)')
subplot(2,2,3), spy(chol(R),4), title('chol(B(r,r))')
subplot(2,2,4), spy(chol(S),4), title('chol(B(s,s))')
```

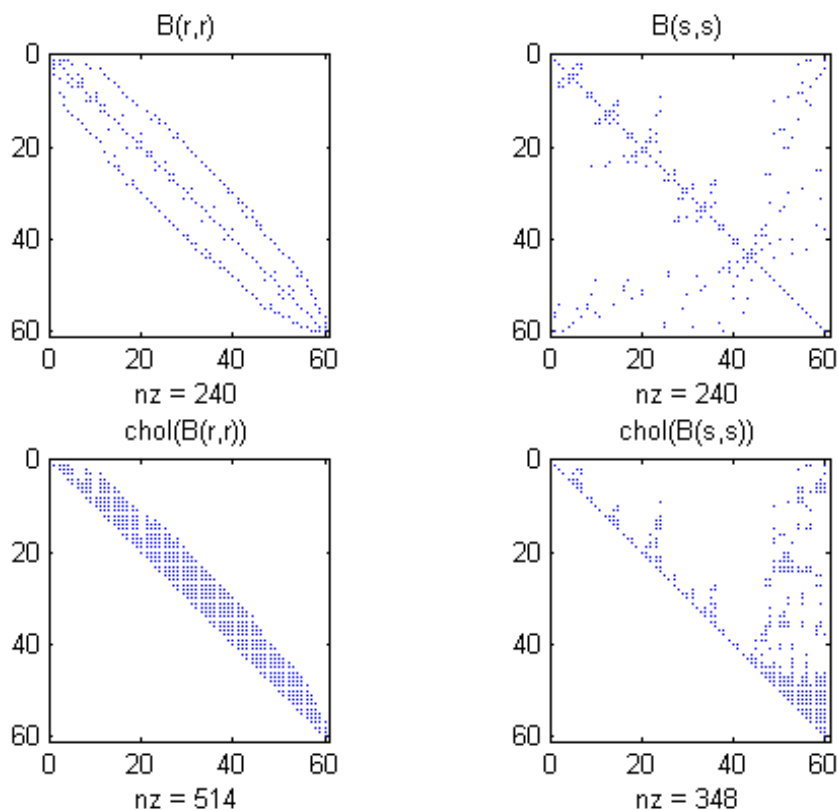

Even though this is a very small problem, the behavior of both orderings is typical. RCM produces a matrix with a narrow bandwidth which fills in almost completely during the Cholesky factorization. Minimum degree produces a structure with large blocks of contiguous zeros which do not fill in during the factorization. Consequently, the minimum degree ordering requires less time and storage for the factorization.

## References

The authors of the code for `symamd` are Stefan I. Larimore and Timothy A. Davis ([davis@cise.ufl.edu](mailto:davis@cise.ufl.edu)), University of Florida.

The algorithm was developed in collaboration with John Gilbert, Xerox PARC, and Esmond Ng, Oak Ridge National Laboratory. Sparse Matrix Algorithms Research at the University of Florida: <http://www.cise.ufl.edu/research/sparse/>

## See Also

`colamd` | `colperm` | `spparms` | `symrcm` | `amd`

# symbfact

---

**Purpose** Symbolic factorization analysis

**Syntax**

```
count = symbfact(A)
count = symbfact(A, 'sym')
count = symbfact(A, 'col')
count = symbfact(A, 'row')
count = symbfact(A, 'lo')
[count,h,parent,post,R] = symbfact(...)
[count,h,parent,post,L] = symbfact(A,type,'lower')
```

**Description**

`count = symbfact(A)` returns the vector of row counts of  $R=\text{chol}(A)$ . `symbfact` should be much faster than `chol(A)`.

`count = symbfact(A, 'sym')` is the same as `count = symbfact(A)`.

`count = symbfact(A, 'col')` returns row counts of  $R=\text{chol}(A'*A)$  (without forming it explicitly).

`count = symbfact(A, 'row')` returns row counts of  $R=\text{chol}(A*A')$ .

`count = symbfact(A, 'lo')` is the same as `count = symbfact(A)` and uses `tril(A)`.

`[count,h,parent,post,R] = symbfact(...)` has several optional return values.

The flop count for a subsequent Cholesky factorization is `sum(count.^2)`

Return Value	Description
h	Height of the elimination tree
parent	The elimination tree itself
post	Postordering of the elimination tree
R	0-1 matrix having the structure of <code>chol(A)</code> for the symmetric case, <code>chol(A'*A)</code> for the 'col' case, or <code>chol(A*A')</code> for the 'row' case.



`symbfact(A)` and `symbfact(A, 'sym')` use the upper triangular part of  $A$  (`triu(A)`) and assume the lower triangular part is the transpose of the upper triangular part. `symbfact(A, 'lo')` uses `tril(A)` instead.

`[count,h,parent,post,L] = symbfact(A,type,'lower')` where `type` is one of `'sym'`, `'col'`, `'row'`, or `'lo'` returns a lower triangular symbolic factor  $L=R'$ . This form is quicker and requires less memory.

## See Also

`chol` | `etree` | `treelayout`

# symmlq

---

## Purpose

Symmetric LQ method

## Syntax

```
x = symmlq(A,b)
symmlq(A,b,tol)
symmlq(A,b,tol,maxit)
symmlq(A,b,tol,maxit,M)
symmlq(A,b,tol,maxit,M1,M2)
symmlq(A,b,tol,maxit,M1,M2,x0)
[x,flag] = symmlq(A,b,...)
[x,flag,relres] = symmlq(A,b,...)
[x,flag,relres,iter] = symmlq(A,b,...)
[x,flag,relres,iter,resvec] = symmlq(A,b,...)
[x,flag,relres,iter,resvec,resveccg] = symmlq(A,b,...)
```

## Description

`x = symmlq(A,b)` attempts to solve the system of linear equations  $A*x=b$  for  $x$ . The  $n$ -by- $n$  coefficient matrix  $A$  must be symmetric but need not be positive definite. It should also be large and sparse. The column vector  $b$  must have length  $n$ . You can specify  $A$  as a function handle, `afun`, such that `afun(x)` returns  $A*x$ .

“Parameterizing Functions” explains how to provide additional parameters to the function `afun`, as well as the preconditioner function `mfun` described below, if necessary.

If `symmlq` converges, a message to that effect is displayed. If `symmlq` fails to converge after the maximum number of iterations or halts for any reason, a warning message is printed displaying the relative residual  $\text{norm}(b-A*x)/\text{norm}(b)$  and the iteration number at which the method stopped or failed.

`symmlq(A,b,tol)` specifies the tolerance of the method. If `tol` is `[]`, then `symmlq` uses the default,  $1e-6$ .

`symmlq(A,b,tol,maxit)` specifies the maximum number of iterations. If `maxit` is `[]`, then `symmlq` uses the default,  $\min(n,20)$ .

`symmlq(A,b,tol,maxit,M)` and `symmlq(A,b,tol,maxit,M1,M2)` use the symmetric positive definite preconditioner  $M$  or  $M = M1*M2$  and effectively solve the system  $\text{inv}(\text{sqrt}(M))*A*\text{inv}(\text{sqrt}(M))*y =$

$\text{inv}(\text{sqrt}(M)) * b$  for  $y$  and then return  $x = \text{in}(\text{sqrt}(M)) * y$ . If  $M$  is  $[]$  then `symmlq` applies no preconditioner.  $M$  can be a function handle `mfun` such that `mfun(x)` returns  $M \backslash x$ .

`symmlq(A,b,tol,maxit,M1,M2,x0)` specifies the initial guess. If  $x_0$  is  $[]$ , then `symmlq` uses the default, an all-zero vector.

`[x,flag] = symmlq(A,b,...)` also returns a convergence flag.

Flag	Convergence
0	<code>symmlq</code> converged to the desired tolerance <code>tol</code> within <code>maxit</code> iterations.
1	<code>symmlq</code> iterated <code>maxit</code> times but did not converge.
2	Preconditioner $M$ was ill-conditioned.
3	<code>symmlq</code> stagnated. (Two consecutive iterates were the same.)
4	One of the scalar quantities calculated during <code>symmlq</code> became too small or too large to continue computing.
5	Preconditioner $M$ was not symmetric positive definite.

Whenever `flag` is not 0, the solution  $x$  returned is that with minimal norm residual computed over all the iterations. No messages are displayed if the `flag` output is specified.

`[x,flag,relres] = symmlq(A,b,...)` also returns the relative residual  $\text{norm}(b - A * x) / \text{norm}(b)$ . If `flag` is 0, `relres`  $\leq$  `tol`.

`[x,flag,relres,iter] = symmlq(A,b,...)` also returns the iteration number at which  $x$  was computed, where  $0 \leq \text{iter} \leq \text{maxit}$ .

`[x,flag,relres,iter,resvec] = symmlq(A,b,...)` also returns a vector of estimates of the `symmlq` residual norms at each iteration, including  $\text{norm}(b - A * x_0)$ .

`[x,flag,relres,iter,resvec,resvecg] = symmlq(A,b,...)` also returns a vector of estimates of the conjugate gradients residual norms at each iteration.

## Examples

### Example 1

```
n = 100;
on = ones(n,1);
A = spdiags([-2*on 4*on -2*on],-1:1,n,n);
b = sum(A,2);
tol = 1e-10;
maxit = 50; M1 = spdiags(4*on,0,n,n);

x = symmlq(A,b,tol,maxit,M1);
symmlq converged at iteration 49 to a solution with relative
residual 4.3e-015
```

### Example 2

This example replaces the matrix  $A$  in Example 1 with a handle to a matrix-vector product function `afun`. The example is contained in the function `run_symmlq` that:

- Calls `symmlq` with the function handle `@afun` as its first argument.
- Contains `afun` as a nested function, so that all variables in `run_symmlq` are available to `afun`.

The following shows the code for `run_symmlq`:

```
function x1 = run_symmlq
n = 100;
on = ones(n,1);
A = spdiags([-2*on 4*on -on],-1:1,n,n);
b = sum(A,2);
tol = 1e-8;
maxit = 15;
M1 = spdiags([on/(-2) on],-1:0,n,n);
M2 = spdiags([4*on -on],0:1,n,n);
x1 = symmlq(@afun,b,tol,maxit,M1);

function y = afun(x)
y = 4 * x;
y(2:n) = y(2:n) - 2 * x(1:n-1);
```

```

 y(1:n-1) = y(1:n-1) - 2 * x(2:n);
 end
end

```

When you enter

```
x1=run_symmlq;
```

MATLAB software displays the message

```
symmlq converged at iteration 49 to a solution with relative
residual 4.3e-015
```

### Example 3

Use a symmetric indefinite matrix that fails with pcg.

```

A = diag([20:-1:1,-1:-1:-20]);
b = sum(A,2); % The true solution is the vector of all ones.
x = pcg(A,b); % Errors out at the first iteration.
pcg stopped at iteration 1 without converging to the desired
tolerance 1e-006 because a scalar quantity became too small or
too large to continue computing.
The iterate returned (number 0) has relative residual 1

```

However, symmlq can handle the indefinite matrix A.

```

x = symmlq(A,b,1e-6,40);
symmlq converged at iteration 39 to a solution with relative
residual 1.3e-007

```

## References

- [1] Barrett, R., M. Berry, T. F. Chan, et al., *Templates for the Solution of Linear Systems: Building Blocks for Iterative Methods*, SIAM, Philadelphia, 1994.
- [2] Paige, C. C. and M. A. Saunders, "Solution of Sparse Indefinite Systems of Linear Equations." *SIAM J. Numer. Anal.*, Vol.12, 1975, pp. 617-629.

# symmlq

---

## See Also

`bicg` | `bicgstab` | `cgs` | `function_handle` | `gmres` | `lsqr` | `minres` |  
`pcg` | `qmr` | `mldivide`

<b>Purpose</b>	Sparse reverse Cuthill-McKee ordering
<b>Syntax</b>	<code>r = symrcm(S)</code>
<b>Description</b>	<p><code>r = symrcm(S)</code> returns the symmetric reverse Cuthill-McKee ordering of <code>S</code>. This is a permutation <code>r</code> such that <code>S(r,r)</code> tends to have its nonzero elements closer to the diagonal. This is a good reordering for LU or Cholesky factorization of matrices that come from long, skinny problems. The ordering works for both symmetric and nonsymmetric <code>S</code>.</p> <p>For a real, symmetric sparse matrix, <code>S</code>, the eigenvalues of <code>S(r,r)</code> are the same as those of <code>S</code>, but <code>eig(S(r,r))</code> probably takes less time to compute than <code>eig(S)</code>.</p>
<b>Algorithms</b>	The algorithm first finds a pseudoperipheral vertex of the graph of the matrix. It then generates a level structure by breadth-first search and orders the vertices by decreasing distance from the pseudoperipheral vertex. The implementation is based closely on the SPARSPAK implementation described by George and Liu.
<b>Examples</b>	<p><b>Reverse Cuthill-McKee Ordering</b></p> <p>The statement</p> <pre>B = bucky;</pre> <p>uses a function in the <code>demos</code> toolbox to generate the adjacency graph of a truncated icosahedron. This is better known as a soccer ball, a Buckminster Fuller geodesic dome (hence the name <code>bucky</code>), or, more recently, as a 60-atom carbon molecule. There are 60 vertices. The vertices have been ordered by numbering half of them from one hemisphere, pentagon by pentagon; then reflecting into the other hemisphere and gluing the two halves together.</p> <p>With this numbering, the matrix does not have a particularly narrow bandwidth, as the first spy plot shows:</p> <pre>figure();</pre>

```
subplot(1,2,1),spy(B),title('B')
```

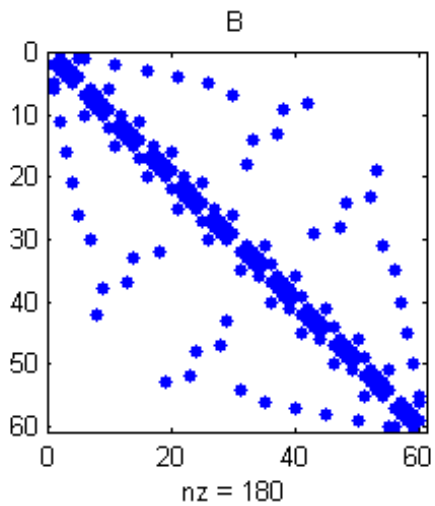

The reverse Cuthill-McKee ordering is obtained with:

```
p = symrcm(B);
R = B(p,p);
```

The spy plot shows a much narrower bandwidth.

```
subplot(1,2,2),spy(R),title('B(p,p)')
```



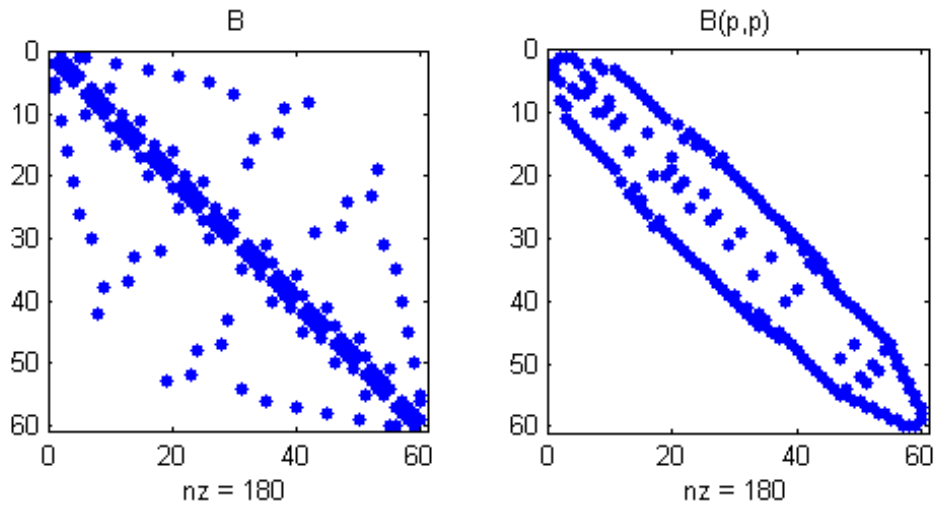

This example is continued in the reference page for `symamd`.

The bandwidth can also be computed with:

```
[i,j] = find(B);
bw = max(i-j) + 1;
```

The bandwidths of `B` and `R` are 35 and 12, respectively.

## References

[1] George, Alan and Joseph Liu, *Computer Solution of Large Sparse Positive Definite Systems*, Prentice-Hall, 1981.

[2] Gilbert, John R., Cleve Moler, and Robert Schreiber, "Sparse Matrices in MATLAB: Design and Implementation," *SIAM Journal on Matrix Analysis*, 1992. A slightly expanded version is also available as a technical report from the Xerox Palo Alto Research Center.

## See Also

colamd | colperm | symamd

**Purpose** Determine symbolic variables in expression

**Syntax** `symvar 'expr'`  
`s = symvar('expr')`

**Description** `symvar 'expr'` searches the expression, `expr`, for identifiers other than `i`, `j`, `pi`, `inf`, `nan`, `eps`, and common functions. `symvar` displays those variables that it finds or, if no such variable exists, displays an empty cell array, `{}`.

`s = symvar('expr')` returns the variables in a cell array of strings, `s`. If no such variable exists, `s` is an empty cell array.

**Examples** `symvar` finds variables `beta1` and `x`, but skips `pi` and the `cos` function.

```
symvar 'cos(pi*x - beta1)'
```

```
ans =
```

```
 'beta1'
```

```
 'x'
```

**See Also** `strfind`

**Purpose** Two ways to call MATLAB functions

**Description** You can call MATLAB functions using either *command syntax* or *function syntax*, as described below.

## **Command Syntax**

A function call in this syntax consists of the function name followed by one or more arguments separated by spaces:

```
functionname arg1 arg2 ... argn
```

Command syntax does not allow you to obtain any values that might be returned by the function. Attempting to assign output from the function to a variable using command syntax generates an error. Use function syntax instead.

Examples of command syntax:

```
save mydata.mat x y z
import java.awt.Button java.lang.String
```

Arguments are treated as string literals. See the examples below, under “Argument Passing” on page 1-6851.

## **Function Syntax**

A function call in this syntax consists of the function name followed by one or more arguments separated by commas and enclosed in parentheses:

```
functionname(arg1, arg2, ..., argn)
```

You can assign the output of the function to one or more output values. When assigning to more than one output variable, separate the variables by commas or spaces and enclose them in square brackets ([ ]):

```
[out1,out2,...,outn] = functionname(arg1, arg2, ..., argn)
```

Examples of function syntax:

```
copyfile('srcfile', '..\mytests', 'writable')
[x1,x2,x3,x4] = deal(A{:})
```

Arguments are passed to the function by value. See the examples below, under “Argument Passing” on page 1-6851.

### Argument Passing

When calling a function using command syntax, MATLAB passes the arguments as string literals. When using function syntax, arguments are passed by value.

In the following example, assign a value to A and then call `disp` on the variable to display the value passed. Calling `disp` with command syntax passes the variable name, 'A':

```
A = pi;
disp A
 A
```

while function syntax passes the value assigned to A:

```
A = pi;
disp(A)
 3.1416
```

The next example passes two strings to `strcmp` for comparison. Calling the function with command syntax compares the variable names, 'str1' and 'str2':

```
str1 = 'one'; str2 = 'one';
strcmp str1 str2
ans =
 0 (unequal)
```

while function syntax compares the values assigned to the variables, 'one' and 'one':

```
str1 = 'one'; str2 = 'one';
strcmp(str1, str2)
```

```
ans =
 1 (equal)
```

## Passing Strings

When using the function syntax to pass a string literal to a function, you must enclose the string in single quotes, ('string'). For example, to create a new folder called `myapptests`, use

```
mkdir('myapptests')
```

On the other hand, variables that contain strings do not need to be enclosed in quotes:

```
folder = 'myapptests';
mkdir(folder)
```

## See Also

`mlint`

## How To

- “Check Code for Errors and Warnings”

**Purpose** Execute operating system command and return output

**Syntax**

```
status = system(command)
[status,cmdout] = system(command)
[status,cmdout] = system(command, '-echo')
```

**Description** `status = system(command)` calls the operating system to execute the specified command. The operation waits for the command to finish execution before returning the exit status of the command to the `status` variable.

`[status,cmdout] = system(command)` additionally returns the output of the command to `cmdout`. This syntax is most useful for commands that do not require user input, such as `dir`.

`[status,cmdout] = system(command, '-echo')` additionally displays (echoes) the command output in the MATLAB Command Window. This syntax is most useful for commands that require user input and that run correctly in the MATLAB Command Window.

## Input Arguments

### **command - Operating system command**

string

Operating system command, specified as a string. The command executes in a system shell, which might not be the shell from which you launched MATLAB.

**Example:** `'dir'`

**Example:** `'ls'`

## Output Arguments

### **status - Command exit status**

0 | nonzero integer

Command exit status, returned as either 0 or a nonzero integer. When the command is successful, `status` is 0. Otherwise, `status` is a nonzero integer.

- If command includes the ampersand character (&), then status is the exit status upon command launch.
- If command does not include the ampersand character (&), then status is the exit status upon command completion.

## **cmdout - Output of operating system command**

string

Output of the operating system command, returned as a string.

## **Examples**

### **Display Windows Operating System Command Status and Output**

On a Windows system, display the current folder using the cd command.

```
command = 'cd';
[status,cmdout] = system(command)
```

```
status =
 0
cmdout =
C:\matlab\myfiles
```

A status of zero indicates that the command completed successfully. MATLAB returns a string containing the current folder in cmdout.

### **Save UNIX Command Exit Status and Output**

List all users who are currently logged in, and save the command exit status and output. Then, view the status.

```
command = 'who';
[status,cmdout] = system(command);
status
```

```
status =
 0
```



---

A `status` of zero indicates that the command completed successfully. MATLAB returns a string containing the list of users in `cmdout`.

## Limitations

- DOS does not support UNC path names. Therefore, if the current folder uses a UNC path name, then running `system` with a DOS command that relies on the current folder fails. To work around this limitation, change the folder to a mapped drive before calling `system`.

## Algorithms

On UNIX, MATLAB uses a shell program to execute the given command. It determines which shell program to use by checking environment variables on your system. MATLAB first checks the `MATLAB_SHELL` variable, and if either empty or not defined, then checks `SHELL`. If `SHELL` is also empty or not defined, MATLAB uses `/bin/sh`.

## Tips

- To execute the operating system command in the background, include the trailing character, `&`, in the command argument (for example, `'notepad &'` on a Windows platform, or `'emacs &'` on UNIX). The exit status is immediately returned to the `status` variable. This syntax is useful for console programs that require interactive user command input while they run, and that do not run correctly in the MATLAB Command Window.

---

**Note** If command includes the trailing `&` character, `cmdout` is empty.

---

- On a UNIX system, the `system` function redirects `stdin` to the invoked command, `command`, by default. This redirection also forwards MATLAB script commands and the keyboard type-ahead buffer to the invoked command while the `system` function executes. This can lead to corrupted output when `system` does not complete execution immediately. To disable `stdin` and type-ahead redirection, include the formatted string `< /dev/null` in the call to the invoked command.

## See Also

`computer` | `dos` | `perl` | `unix` | ! (exclamation point)

# system

---

## **Concepts**

- “Run External Commands, Scripts, and Programs”

**Purpose**

Create table from workspace variables

**Syntax**

```
T = table(var1,...,varN)
T = table(var1,...,varN,Name,Value)
T = table
```

**Description**

`T = table(var1,...,varN)` creates a table from the input variables, `var1,...,varN`. Variables can be of different sizes and data types, but all variables must have the same number of rows.

If the inputs are workspace variables, `table` uses the workspace variable names as variable names for the table. Otherwise, `table` uses strings of the form `'Var1',...,'VarN'` where `N` is the number of variables.

For more information on creating and using the `table` data type, see “Tables”.

`T = table(var1,...,varN,Name,Value)` includes additional options specified by one or more `Name,Value` pair arguments.

For example, you can specify row names or variable names to include in the table.

`T = table` creates an empty 0-by-0 table.

**Input Arguments****var1,...,varN - Input variables**

arrays with the same number of rows

Input variables, specified as arrays with the same number of rows. The input variables can be of different sizes and different data types.

Common input variables are numeric arrays, logical arrays, character arrays, structure arrays, or cell arrays. Furthermore, input variables can be objects that are arrays that support indexing of the form `var(index1,...,indexN)`, where `index1` is a numeric or logical vector that corresponds to rows of the variable `var`. In addition, the array must implement a `vertcat` method and a `size` method with a `dim` argument.

# table

---

**Example:** `table([1:4]', ones(4,3,2), eye(4,2))` creates a table from variables with 4 rows, but different sizes.

**Example:** `table([1:3]', {'one'; 'two'; 'three'}, ['A'; 'B'; 'C'])` creates a table from variables with 3 rows, but different data types.

## **Name-Value Pair Arguments**

Specify optional comma-separated pairs of **Name**, **Value** arguments. **Name** is the argument name and **Value** is the corresponding value. **Name** must appear inside single quotes ( ' '). You can specify several name and value pair arguments in any order as **Name1**, **Value1**, ..., **NameN**, **ValueN**.

**Example:** `'RowNames', {'row1', 'row2', 'row3'}` names the rows `row1`, `row2`, and `row3`.

### **'RowNames' - Row names**

`{}` (default) | cell array of nonempty, distinct strings

Row names, specified as the comma-separated pair consisting of `'RowNames'` and a cell array of nonempty, distinct strings. The number of strings must equal the number of rows in the table.

### **'VariableNames' - Variable names**

cell array of nonempty, distinct strings

Variable names, specified as the comma-separated pair consisting of `'VariableNames'` and a cell array of nonempty, distinct strings. The number of strings must equal the number of variables.

If the input variables, `var1`, ..., `varN`, are valid MATLAB identifiers, `table` uses the workspace variable names. Otherwise, `table` uses a cell array of `N` strings of the form `{'Var1', ..., 'VarN'}`, where `N` is the number of variables. You can determine valid MATLAB variable names using the function `isvarname`.

**Output Arguments****T - Output table**

table

Output table, returned as a table. The table can store metadata such as descriptions, variable units, variable names, and row names. For more information, see [Table Properties](#).

**Examples****Create Table from Workspace Variables**

Define workspace variables with the same number of rows.

```
LastName = {'Smith';'Johnson';'Williams';'Jones';'Brown'};
Age = [38;43;38;40;49];
Height = [71;69;64;67;64];
Weight = [176;163;131;133;119];
BloodPressure = [124 93; 109 77; 125 83; 117 75; 122 80];
```

Create a table, T, as a container for the workspace variables.

```
T = table(Age,Height,Weight,BloodPressure,...
 'RowNames',LastName)
```

T =

	Age	Height	Weight	BloodPressure	
Smith	38	71	176	124	93
Johnson	43	69	163	109	77
Williams	38	64	131	125	83
Jones	40	67	133	117	75
Brown	49	64	119	122	80

table names the variables with the workspace variable names.

**Create Table and Specify Variable Names**

Create a table from arrays with different data types.

# table

---

```
T = table(['M';'F';'M'],[45;32;34],...
 {'NY';'CA';'MA'},logical([1;0;0]),...
 'VariableNames',{'Gender' 'Age' 'State' 'Vote'})
```

T =

Gender	Age	State	Vote
M	45	'NY'	true
F	32	'CA'	false
M	34	'MA'	false

Each variable in T contains 3 rows.

Gender is a character array, Age is a double-precision array, State is a cell array of strings, and Vote is a logical array. You can use the function `summary` to print the data type and other information about the variables in the table.

## See Also

`readtable` | `cell2table` | `array2table` | `struct2table` | `isvarname`  
| `summary`

## Related Examples

- “Create a Table”
- “Modify Units, Descriptions and Table Variable Names”
- “Access Data in a Table”

**Purpose** Convert table to homogenous array

**Syntax** `A = table2array(T)`

**Description** `A = table2array(T)` converts the table, `T`, to a homogeneous array, `A`.

**Input Arguments** **T - Input table**

table

Input table, specified as a table. All variables in `T` must have sizes and data types that are compatible for horizontal concatenation. Specifically, the size of all variable dimensions greater than 2 must match.

- If `T` is an `m`-by-`n` table with variables that each have one column, then each variable becomes one column in `A`, and `A` is an `m`-by-`n` array.
- If `T` contains variables that consist of more than one column, those variables become multiple columns in `A`, and the size of `A` is greater than the size of `T`.
- If `T` contains variables with more than two dimensions, the number of dimensions of `A` is the same as the number of variable dimensions.

**Examples** **Convert Table of Numeric Data to Array**

Create a table, `T`, consisting of numeric data.

```
T = table([1;2;3],[2 8; 4 10; 6 12],[3 12 21; 6 15 24; 9 18 27],...
 'VariableNames',{'One' 'Two' 'Three'})
```

`T =`

	One	Two		Three	
	—	—————		—————	
1	2	8	3	12	21
2	4	10	6	15	24
3	6	12	9	18	27

# table2array

---

Convert table, T, to an array.

```
A = table2array(T)
```

```
A =
```

```
 1 2 8 3 12 21
 2 4 10 6 15 24
 3 6 12 9 18 27
```

A contains two columns from variable Two and three columns from variable Three.

## Convert Numeric Subset of Table to Array

Define the numeric subset of a table to convert to an array.

Create a table with nonnumeric data in the first variable.

```
T = table(['M';'M';'F';'F';'F'],[38;43;38;40;49],...
 [71;69;64;67;64],[176;163;131;133;119],...
 'VariableNames',{'Gender' 'Age' 'Height' 'Weight'})
```

```
T =
```

Gender	Age	Height	Weight
M	38	71	176
M	43	69	163
F	38	64	131
F	40	67	133
F	49	64	119

Convert T(:,2:4) to an array.

```
A = table2array(T(:,2:4))
```

```
A =
```



```

38 71 176
43 69 163
38 64 131
40 67 133
49 64 119

```

A does not include data from the variable Gender.

## Convert Table with Three-Dimensional Variables to Array

Create a table, T, with two rows and three variables where each variable has three dimensions.

```
T = table(ones(2,1,3),2*ones(2,2,3),3*ones(2,3,3),...
 'VariableNames',{'One' 'Two' 'Three'})
```

T =

One	Two	Three
[1x1x3 double]	[1x2x3 double]	[1x3x3 double]
[1x1x3 double]	[1x2x3 double]	[1x3x3 double]

The size of the table is 2-by-3.

Convert table T to an array.

```
A = table2array(T)
```

A(:, :, 1) =

```

1 2 2 3 3 3
1 2 2 3 3 3

```

A(:, :, 2) =

```

1 2 2 3 3 3

```

# table2array

---

```
 1 2 2 3 3 3
 1 2 2 3 3 3
 1 2 2 3 3 3
```

The size of A is 2-by-6-by-3.

## Algorithms

If T contains variables with different data types that are compatible for horizontal concatenation, `table2array` creates a homogeneous array, A, of the dominant data type. For example, if T contains `double` and `single` numeric data, `table2array(T)` returns an array with data type `single`.

## Tips

- `table2array` horizontally concatenates the variables in T to create A. If the variables in T are cell arrays, `table2array` does not concatenate their contents, and A is a cell array, equivalent to `table2cell(T)`. To create an array containing the contents of variables that are all cell arrays, use `cell2mat(table2cell(T))`.
- `table2array(T)` is equivalent to `T{:,:}`.

## See Also

`array2table` | `table2cell` | `table2struct` | `table`

## Concepts

- “Concatenating Objects of Different Classes”

**Purpose** Convert table to cell array

**Syntax** `C = table2cell(T)`

**Description** `C = table2cell(T)` converts the table, `T`, to a cell array, `C`. Each variable in `T` becomes a column of cells in `C`.

**Input Arguments** **T - Input table**  
table

Input table, specified as a table.

If `T` is an `m`-by-`n` table, then `C` is an `m`-by-`n` cell array.

**Examples** **Convert Table to Cell Array**

Create a table, `T`, with five rows and three variables.

```
T = table(['M';'M';'F';'F';'F'],[38;43;38;40;49],...
 [124 93;109 77; 125 83; 117 75; 122 80],...
 'VariableNames',{'Gender' 'Age' 'BloodPressure'},...
 'RowNames',{'Smith' 'Johnson' 'Williams' 'Jones' 'Brown'})
```

`T =`

	Gender	Age	BloodPressure	
	_____	_____	_____	_____
Smith	M	38	124	93
Johnson	M	43	109	77
Williams	F	38	125	83
Jones	F	40	117	75
Brown	F	49	122	80

Convert `T` to a cell array.

```
C = table2cell(T)
```

# table2cell

---

```
C =

 'M' [38] [1x2 double]
 'M' [43] [1x2 double]
 'F' [38] [1x2 double]
 'F' [40] [1x2 double]
 'F' [49] [1x2 double]
```

C is a 5-by-3 cell array.

Vertically concatenate the table property, `T.Properties.VariableNames`, with C to include column headings for the cell array.

```
[T.Properties.VariableNames;C]
```

```
ans =

 'Gender' 'Age' 'BloodPressure'
 'M' [38] [1x2 double]
 'M' [43] [1x2 double]
 'F' [38] [1x2 double]
 'F' [40] [1x2 double]
 'F' [49] [1x2 double]
```

`T.Properties.VariableNames` is a cell array of strings.

## See Also

[cell2table](#) | [table2array](#) | [table2struct](#) | [table](#)

**Purpose** Convert table to structure array

**Syntax**

```
S = table2struct(T)
S = table2struct(T,'ToScalar',true)
```

**Description** `S = table2struct(T)` converts the table, `T`, to a structure array, `S`. Each variable of `T` becomes a field in `S`. If `T` is an `m`-by-`n` table, then `S` is a `m`-by-1 structure array with `n` fields.

`S = table2struct(T,'ToScalar',true)` converts the table, `T`, to a scalar structure `S`. Each variable of `T` becomes a field in `S`. If `T` is a `m`-by-`n` table, then `S` has `n` fields, each of which has `m` rows.

**Input Arguments**

**T - Input table**  
table

Input table, specified as a table.

**Examples**

**Convert Table to Structure Array**

Create a table, `T`, with five rows and three variables.

```
T = table(['M';'M';'F';'F';'F'],[38;43;38;40;49],...
 [124 93;109 77; 125 83; 117 75; 122 80],...
 'VariableNames',{'Gender' 'Age' 'BloodPressure'})
```

`T =`

	Gender	Age	BloodPressure	
	M	38	124	93
	M	43	109	77
	F	38	125	83
	F	40	117	75
	F	49	122	80

# table2struct

---

Convert T to a structure array.

```
S = table2struct(T)
```

```
S =
```

```
5x1 struct array with fields:
```

```
 Gender
 Age
 BloodPressure
```

The structure is 5-by-1, corresponding to the five rows of the table, T. The three fields of S correspond to the three variables from T.

Display the field data for the first element of S.

```
S(1)
```

```
ans =
```

```
 Gender: 'M'
 Age: 38
 BloodPressure: [124 93]
```

The information corresponds to the first row of the table.

## Convert Table to Scalar Structure

Create a table, T, with five rows and three variables.

```
T = table(['M';'M';'F';'F';'F'],[38;43;38;40;49],...
 [124 93;109 77; 125 83; 117 75; 122 80],...
 'VariableNames',{'Gender' 'Age' 'BloodPressure'})
```

```
T =
```

```
 Gender Age BloodPressure
 _____ _____ _____
```

M	38	124	93
M	43	109	77
F	38	125	83
F	40	117	75
F	49	122	80

Convert T to a scalar structure.

```
S = table2struct(T,'ToScalar',true)
```

```
S =
```

```
 Gender: [5x1 char]
 Age: [5x1 double]
 BloodPressure: [5x2 double]
```

The data in the fields of the scalar structure are 5-by-1, corresponding to the five rows in the table T.

Display the data for the field BloodPressure.

```
S.BloodPressure
```

```
ans =
```

124	93
109	77
125	83
117	75
122	80

The structure field BloodPressure contains all of the data that was in the variable of the same name from table T.

## Convert Table with Row Names to Structure

Create a table, T, that includes row names.

# table2struct

---

```
T = table(['M';'M';'F';'F';'F'],[38;43;38;40;49],...
 [124 93;109 77; 125 83; 117 75; 122 80],...
 'VariableNames',{'Gender' 'Age' 'BloodPressure'},...
 'RowNames',{'Smith' 'Johnson' 'Williams' 'Jones' 'Brown'})
```

T =

	Gender	Age	BloodPressure	
	-----	-----	-----	-----
Smith	M	38	124	93
Johnson	M	43	109	77
Williams	F	38	125	83
Jones	F	40	117	75
Brown	F	49	122	80

Convert T to a scalar structure.

```
S = table2struct(T,'ToScalar',true)
```

S =

```
Gender: [5x1 char]
Age: [5x1 double]
BloodPressure: [5x2 double]
```

Add a field for the row names from the table.

```
S.RowNames = T.Properties.RowNames
```

S =

```
Gender: [5x1 char]
Age: [5x1 double]
BloodPressure: [5x2 double]
RowNames: {5x1 cell}
```



If `S` is a nonscalar structure, use `[S.RowNames] = T.Properties.RowNames{:}` to include a field with the row names from the table.

## See Also

[struct2table](#) | [table2cell](#) | [table2array](#) | [table](#)

# Table Properties

---

## Purpose

Access and modify table metadata properties

## Access and Modify Properties

A table, *T*, has properties that store metadata such as its variable names, row names, descriptions, and variable units. *T.Properties* returns a summary of all of the table properties.

You can access a property using *T.Properties.PropName*, where *T* is the name of the table and *PropName* is one of the table properties. For example, to access the *VariableDescriptions* property of a table named *Patients*, use *Patients.Properties.VariableDescriptions*.

You can modify a property value using *T.Properties.PropName = P* where *T* is the name of the table, *PropName* is one of the table properties, and *P* is the desired property value. For example, to modify the *VariableUnits* property of a table named *Patients*, use *Patients.Properties.VariableUnits = P* where *P* is a cell array of strings containing the specified information.

In contrast, you can access and modify variables within a table using *T.Variable* or *T.Variable = V*, where *T* is the name of the table, *Variable* is the name of the variable you want to access or modify, and *V* is the variable value you want.

## Properties

### VariableNames - Variable names

cell array of nonempty, distinct strings

Variable names, specified as a cell array of nonempty, distinct strings. The number of strings must equal the number of variables. MATLAB removes any leading or trailing white space from the strings.

If valid MATLAB identifiers are not available for use as variable names, MATLAB uses a cell array of *N* strings of the form { 'Var1' . . . 'Var*N*' } where *N* is the number of variables. You can determine valid MATLAB variable names using the function *isvarname*.

The variable names are visible when viewing the table and when using the summary function. Furthermore, you can use the variable names within parentheses, within curly braces, or with dot indexing to access table data.

## Example

```
%% Create a table
```

```
T = table(['M';'M';'F';'F';'F'],[38;43;38;40;49],...
 [71;69;64;67;64],[176;163;131;133;119])
```

```
T =
```

Var1	Var2	Var3	Var4
M	38	71	176
M	43	69	163
F	38	64	131
F	40	67	133
F	49	64	119

```
%% Modify variable names
```

```
T.Properties.VariableNames = {'Gender' 'Age' 'Height' 'Weight'}
```

```
T =
```

Gender	Age	Height	Weight
M	38	71	176
M	43	69	163
F	38	64	131
F	40	67	133
F	49	64	119

```
%% Create a subtable
```

```
%
```

```
% Use variable names within parentheses to create a subtable.
```

```
% Include all the rows, but only the variables Age and Gender.
```

```
T(:,{'Age','Gender'})
```

```
ans =
```

# Table Properties

---

Age	Gender
38	M
43	M
38	F
40	F
49	F

```
%% Extract data from the table
%
% Use variable names within curly braces to extract the
% numeric data from the variables Height and Weight.
T(:,:,{'Height','Weight'})
```

```
ans =
```

71	176
69	163
64	131
67	133
64	119

```
% Use variable names with dot indexing to extract
% all the data from the variable Gender.
T.Gender
```

```
ans =
```

```
M
M
F
F
F
```

**RowNames - Row names**

`{}` (default) | cell array of nonempty, distinct strings

Row names, specified as a cell array of nonempty, distinct strings. This property can be empty, but if not empty, the number of strings must equal the number of rows in the table. MATLAB removes any leading or trailing white space from the strings. The default property value is an empty cell array.

The row names are visible when you view the table. Furthermore, you can use the row names within parentheses or curly braces to access the table data.

## Example

```
% Create a table
load patients
T = table(Gender, Age, Height, Weight, Smoker, Systolic, Diastolic);

% Add row names
T.Properties.RowNames = LastName;

% Remove row names
T.Properties.RowNames = {};
```

## DimensionNames - Dimension names

`{'Row' `Variable'}` (default) | two-element cell array of strings

Dimension names, specified as a two-element cell array of strings.

## Example

```
% Create a table
load patients
T = table(Gender, Age, Height, Weight, Smoker, Systolic, Diastolic, ...
 'RowNames', LastName);

% Add dimension names
T.Properties.DimensionNames = {'Patient' 'Data'};
```

## Description - Table description

# Table Properties

---

'' (default) | string

Table description, specified as a string. This string is visible when using the summary function.

## Example

```
% Create a table
load patients
T = table(Gender, Age, Height, Weight);

% Add a table description
T.Properties.Description = 'Simulated patient data';

%View the summary
format compact
summary(T)
```

Description: Simulated patient data

Variables:

Gender: 100x1 char

Age: 100x1 double

Values:

min 25

median 39

max 50

Height: 100x1 double

Values:

min 60

median 67

max 72

Weight: 100x1 double

Values:

min 111

median 142.5

max 202

## VariableDescriptions - Variable descriptions

`{}` (default) | cell array of strings

Variable descriptions, specified as a cell array of strings. This property can be an empty cell array, which is the default. If the cell array is not empty, the number of strings must equal the number of variables. You can specify an individual empty string within the cell array for a variable that does not have a description.

The variable descriptions are visible when using the summary function.

## Example

```
% Create a table
load patients
T = table(Gender, Age, Height, Weight, Smoker, Systolic, Diastolic);

% Add variable descriptions
T.Properties.VariableDescriptions = {' ' ' ' ' ' ...
 'Has the patient ever been a smoker' ...
 'Systolic Pressure' 'Diastolic Pressure'};

% View the summary
format compact
summary(T)
```

```
Variables:
 Gender: 100x1 char
 Age: 100x1 double
 Values:
 min 25
 median 39
 max 50
 Height: 100x1 double
 Values:
 min 60
 median 67
 max 72
 Weight: 100x1 double
 Values:
```

# Table Properties

---

```
 min 111
 median 142.5
 max 202
Smoker: 100x1 logical
 Description: Has the patient ever been a smoker
 Values:
 true 34
 false 66
Systolic: 100x1 double
 Description: Systolic Pressure
 Values:
 min 109
 median 122
 max 138
Diastolic: 100x1 double
 Description: Diastolic Pressure
 Values:
 min 68
 median 81.5
 max 99
```

```
% Remove all the variable descriptions
T.Properties.VariableDescriptions = {};
```

## VariableUnits - Variable units

`{}` (default) | cell array of strings

Variable units, specified as a cell array of strings. This property can be an empty cell array, which is the default. If the cell array is not empty, the number of strings must equal the number of variables. You can specify an individual empty string within the cell array for a variable that does not have units.

The variable units are visible when using the summary function.

## Example

```
% Create a table
load patients
```



```
T = table(Gender, Age, Height, Weight, Smoker, Systolic, Diastolic);

% Add variable units
T.Properties.VariableUnits = {' ' 'Yrs' 'In' 'Lbs' ' ' 'mm Hg' 'mm Hg'};

% View the summary
format compact
summary(T)
```

```
Variables:
 Gender: 100x1 char
 Age: 100x1 double
 Units: Yrs
 Values:
 min 25
 median 39
 max 50
 Height: 100x1 double
 Units: In
 Values:
 min 60
 median 67
 max 72
 Weight: 100x1 double
 Units: Lbs
 Values:
 min 111
 median 142.5
 max 202
 Smoker: 100x1 logical
 Values:
 true 34
 false 66
 Systolic: 100x1 double
 Units: mm Hg
 Values:
 min 109
```

# Table Properties

---

```
 median 122
 max 138
Diastolic: 100x1 double
Units: mm Hg
Values:
 min 68
 median 81.5
 max 99
```

```
% Remove all the variable units
T.Properties.VariableUnits = {};
```

## **UserData - Additional table information**

`{}` (default) | variable containing information in any data type

Additional table information, specified as a variable containing information in any data type.

## **Example**

```
% Create a table
load patients
T = table(Gender, Age, Height, Weight, Smoker, Systolic, Diastolic);

% Add an anonymous function to the table metadata
formula = @(x) x.^2;
T.Properties.UserData = formula;
```

## **See Also**

`table` | `summary` | `isvarname`

## **Concepts**

- “Access Data in a Table”

<b>Purpose</b>	Tangent of argument in radians
<b>Syntax</b>	$Y = \tan(X)$
<b>Description</b>	$Y = \tan(X)$ returns the tangent of each element of $X$ . The $\tan$ function operates element-wise on arrays. The function accepts both real and complex inputs. For real values of $X$ in the interval $[-\text{Inf}, \text{Inf}]$ , $\tan$ returns real values in the interval $[-\text{Inf}, \text{Inf}]$ . For complex values of $X$ , $\tan$ returns complex values. All angles are in radians.
<b>Input Arguments</b>	<b>X - Input angle in radians</b> scalar value   vector   matrix   N-D array  Input angle, specified as a real-valued or complex-valued scalar, vector, matrix or N-D array. The $\tan$ operation is element-wise when $X$ is non-scalar. <b>Data Types</b> single   double <b>Complex Number Support:</b> Yes
<b>Output Arguments</b>	<b>Y - Tangent of input angle</b> scalar value   vector   matrix   N-D array  Tangent of input angle, returned as a real-valued or complex-valued scalar, vector, matrix or N-D array.
<b>Examples</b>	<b>Plot Tangent Function</b>  Plot the tangent function over the domain $-\pi/2 \leq x \leq \pi/2$ .  <pre>x = (-pi/2)+0.01:0.01:(pi/2)-0.01; plot(x,tan(x)), grid on</pre>

# tan

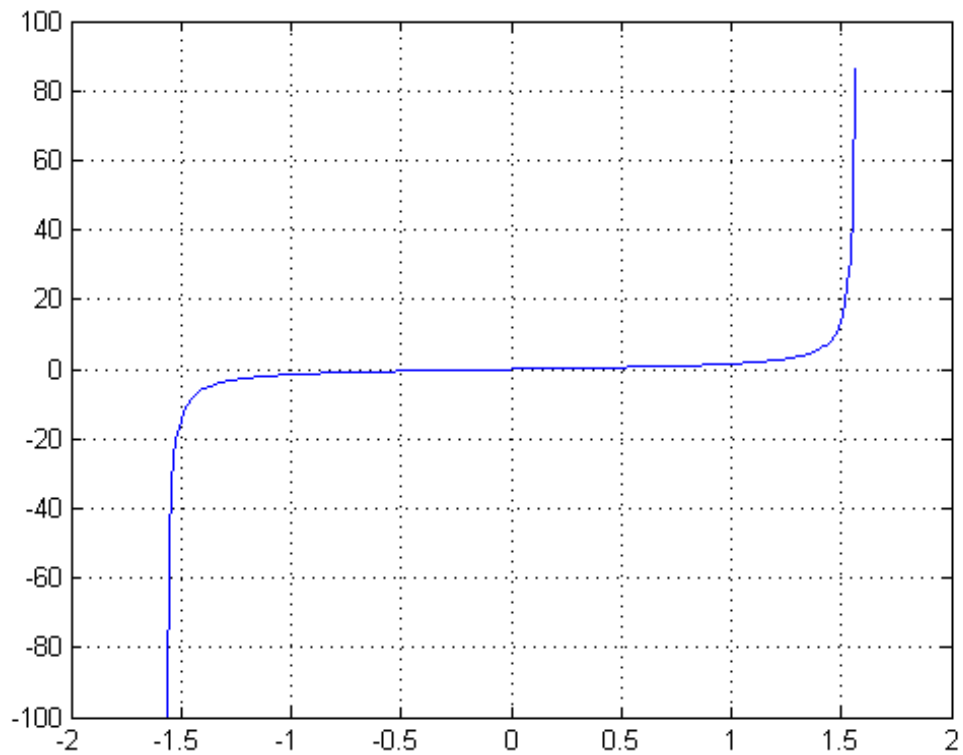

## Tangent of Vector of Complex Angles

Calculate the tangent of the complex angles in vector x.

```
x = [-i pi+i*pi/2 -1+i*4];
y = tan(x)
```

y =

$$0.0000 - 0.7616i \quad -0.0000 + 0.9172i \quad -0.0006 + 1.0003i$$

**Definitions****Tangent Function**

The tangent of an angle,  $\alpha$ , defined with reference to a right angled triangle is

$$\text{tangent}(\alpha) = \frac{\text{opposite side}}{\text{adjacent side}} = \frac{a}{b}.$$

# tan

---

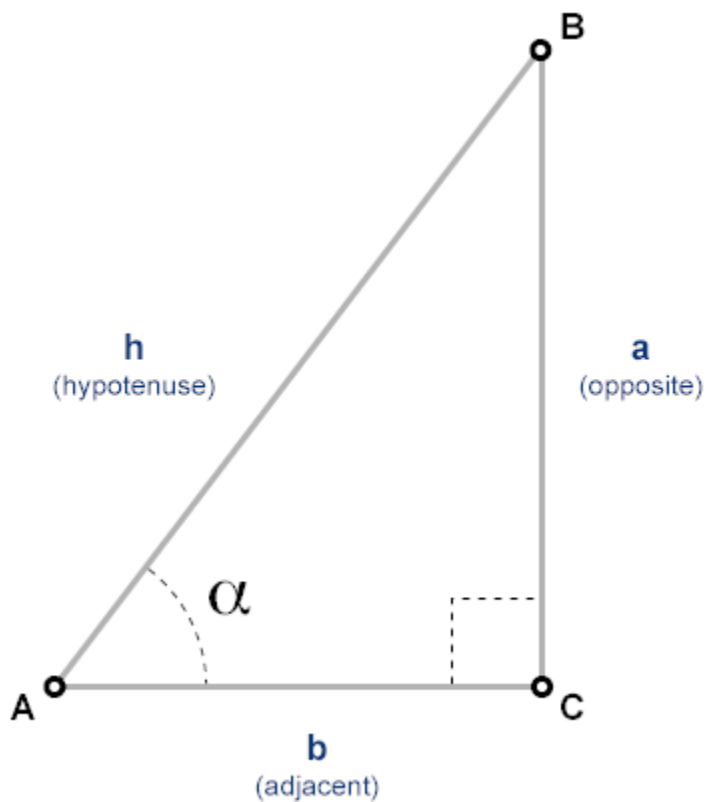

The tangent of a complex angle,  $\alpha$ , is

$$\text{tangent}(\alpha) = \frac{e^{i\alpha} - e^{-i\alpha}}{i(e^{i\alpha} + e^{-i\alpha})}.$$

## See Also

[tand](#) | [tanh](#) | [atan](#) | [atan2](#) | [atand](#) | [atan2d](#)

<b>Purpose</b>	Tangent of argument in degrees
<b>Syntax</b>	$Y = \text{tand}(X)$
<b>Description</b>	$Y = \text{tand}(X)$ returns the tangent of the elements of $X$ , which are expressed in degrees.
<b>Input Arguments</b>	<p><b>X - Angle in degrees</b> scalar value   vector   matrix   N-D array</p> <p>Angle in degrees, specified as a real-valued or complex-valued scalar, vector, matrix, or N-D array. The <code>tand</code> operation is element-wise when <math>X</math> is nonscalar.</p> <p><b>Data Types</b> single   double</p> <p><b>Complex Number Support:</b> Yes</p>
<b>Output Arguments</b>	<p><b>Y - Tangent of angle</b> scalar value   vector   matrix   N-D array</p> <p>Tangent of angle, returned as a real-valued or complex-valued scalar, vector, matrix, or N-D array of the same size as <math>X</math>.</p>
<b>Examples</b>	<p><b>Tangent of 90 degrees compared to tangent of <math>\pi/2</math> radians</b></p> <pre>tand(90)  ans =       Inf  tan(pi/2)  ans =      1.6331e+16  tand(90) is infinite, whereas tan(pi/2) is large but finite.</pre>

# tand

---

## Tangent of vector of complex angles, specified in degrees

```
z = [180+i 15+2i 10+3i];
y = tand(z)
```

```
y =
```

```
0 + 0.0175i 0.2676 + 0.0374i 0.1758 + 0.0539i
```

## See Also

[atand](#) | [tan](#) | [atan](#)



**Purpose** Hyperbolic tangent

**Syntax**  $Y = \tanh(X)$

**Description** The tanh function operates element-wise on arrays. The function's domains and ranges include complex values. All angles are in radians.  $Y = \tanh(X)$  returns the hyperbolic tangent of each element of  $X$ .

**Examples** **Graph Hyperbolic Tangent Function**

Graph the hyperbolic tangent function over the domain  $-5 \leq x \leq 5$ .

```
x = -5:0.01:5;
plot(x,tanh(x)), grid on
```

# tanh

---

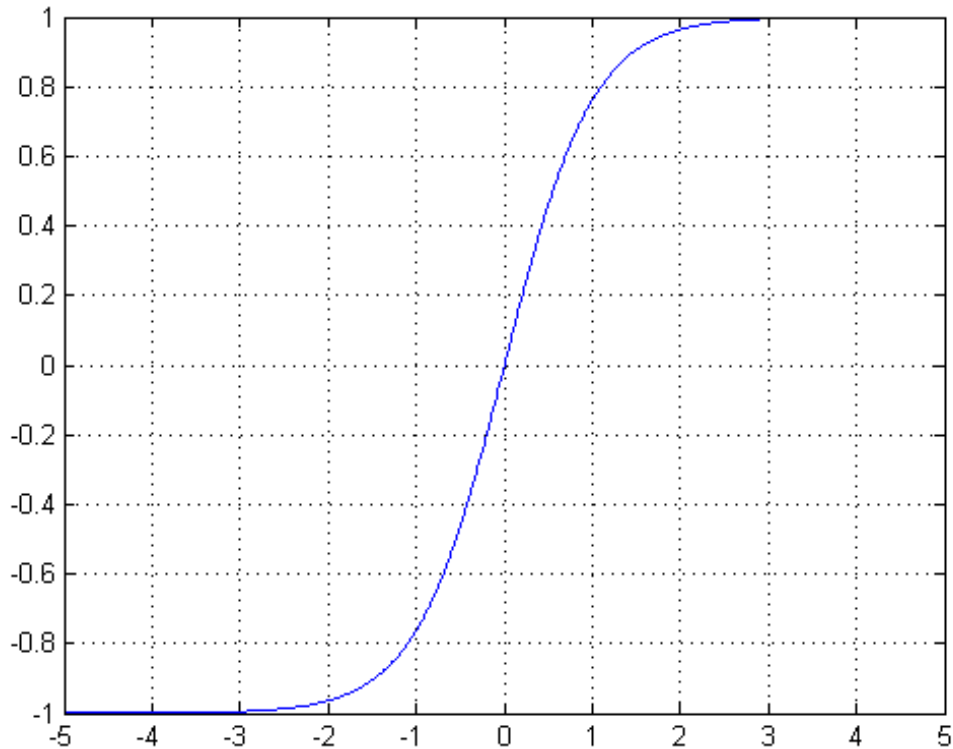

## Definitions **Hyperbolic Tangent**

The hyperbolic tangent of  $z$  is

$$\tanh(z) = \frac{\sinh(z)}{\cosh(z)}.$$

**See Also**     [atan](#) | [atan2](#) | [tan](#) | [atanh](#) | [sinh](#) | [cosh](#)

---

<b>Purpose</b>	Compress files into tar file
<b>Syntax</b>	<pre>tar(<i>tarfilename</i>,<i>files</i>) tar(<i>tarfilename</i>,<i>files</i>,<i>rootfolder</i>) entrynames = tar(...)</pre>
<b>Description</b>	<p><code>tar(<i>tarfilename</i>,<i>files</i>)</code> creates a tar file named <i>tarfilename</i> from the list of files and folders specified in <i>files</i>. Folders recursively include all of their content. If <i>files</i> includes relative paths, the tar file also contains relative paths. The tar file does not include absolute paths.</p> <p><code>tar(<i>tarfilename</i>,<i>files</i>,<i>rootfolder</i>)</code> specifies the path for <i>files</i> relative to <i>rootfolder</i> rather than the current folder. Relative paths in the tar file reflect the relative paths in <i>files</i>, and do not include path information from <i>rootfolder</i>.</p> <p><code>entrynames = tar(...)</code> returns a string cell array of the names of the files contained in <i>tarfilename</i>. If <i>files</i> includes relative paths, <i>entrynames</i> also contains relative paths.</p>
<b>Tips</b>	tar cannot compress folders larger than 2 GB.
<b>Input Arguments</b>	<p><b>tarfilename</b></p> <p>String specifying the name of the tar file. If <i>tarfilename</i> has no extension, MATLAB appends the <code>.tar</code> extension. The <i>tarfilename</i> extension can end in <code>.tgz</code> or <code>.gz</code>. In this case, <i>tarfilename</i> is gzipped.</p> <p><b>files</b></p> <p>String or cell array of strings containing the list of files or folders included in <i>tarfilename</i>.</p> <p>Individual files that are on the MATLAB path can be specified as partial path names. Otherwise an individual file can be specified relative to the current folder or with an absolute path.</p> <p>Folders must be specified relative to the current folder or with absolute paths. On UNIX systems, folders can also start with <code>~/</code> or <code>~username/</code>,</p>

# tar

---

which expands to the current user's home folder or the specified user's home folder, respectively. The wildcard character `*` can be used when specifying files or folders, except when relying on the MATLAB path to resolve a file name or partial path name.

## **rootfolder**

String specifying the path for *files*.

## **Examples**

Tar all files in the current folder to the file `backup.tgz`.

```
tar('backup.tgz','.');
```

## **See Also**

`gzip` | `gunzip` | `untar` | `unzip` | `zip`

<b>Purpose</b>	Name of system's temporary folder
<b>Syntax</b>	<code>tmp_folder = tempdir</code>
<b>Description</b>	<code>tmp_folder = tempdir</code> returns the name of the system's temporary folder, if one exists. This function does not create a new folder.
<b>See Also</b>	<code>delete</code>   <code>recycle</code>   <code>tempname</code>
<b>How To</b>	<ul style="list-style-type: none"><li>• “Create Temporary Files”</li></ul>

# tempname

---

**Purpose** Unique name for temporary file

**Syntax** tmpName = tempname

**Description** tmpName = tempname returns a string, tmpName, suitable for use as a temporary file path in your system's temporary folder.

## **Examples** Create Temporary File Name with Extension

Create a temporary file name that has the extension, .dat, by concatenating two strings.

```
tmpName = [tempname, '.dat'];
```

## **Write Data to Temporary File**

Create a temporary file name.

```
filename = tempname;
```

Create a new file with the temporary file name, and write data to the file.

```
fileID = fopen(filename, 'w');
fwrite(fileID, magic(5));
fclose(fileID);
```

**Limitations**

- In most cases, tempname generates a universally unique identifier (UUID). However, if you run MATLAB without JVM software, then tempname generates a random string using the CPU counter and time, and this string is not guaranteed to be unique. For more information about the MATLAB startup option that does not load JVM software, see “Commonly Used Startup Options”.

**See Also** tempdir

**Concepts**

- “Create Temporary Files”

**Purpose**

Tetrahedron mesh plot

**Syntax**

```
tetramesh(T,X,c)
tetramesh(T,X)
tetramesh(TR)
h = tetramesh(...)
tetramesh(...,'param','value','param','value'...)
```

**Description**

`tetramesh(T,X,c)` displays the tetrahedrons defined in the  $m$ -by-4 matrix  $T$  as mesh.  $T$  is usually the output of a Delaunay triangulation of a 3-D set of points. A row of  $T$  contains indices into  $X$  of the vertices of a tetrahedron.  $X$  is an  $n$ -by-3 matrix, representing  $n$  points in 3 dimension. The tetrahedron colors are defined by the vector  $C$ , which is used as indices into the current colormap.

`tetramesh(T,X)` uses  $C = 1:m$  as the color for the  $m$  tetrahedra. Each tetrahedron has a different color (modulo the number of colors available in the current colormap).

`tetramesh(TR)` displays the tetrahedra in a triangulation representation.

`h = tetramesh(...)` returns a vector of tetrahedron handles. Each element of  $h$  is a handle to the set of patches forming one tetrahedron. You can use these handles to view a particular tetrahedron by turning the patch 'Visible' property 'on' or 'off'.

`tetramesh(...,'param','value','param','value'...)` allows additional patch property name/property value pairs to be used when displaying the tetrahedrons. For example, the default transparency parameter is set to 0.9. You can overwrite this value by using the property name/property value pair ('FaceAlpha',value) where value is a number between 0 and 1. See Patch Properties for information about the available properties.

**Examples****Plot Tetrahedrons of 3-D Delaunay Triangulation**

Generate a 3-D Delaunay triangulation, then use `tetramesh` to visualize the tetrahedrons.

# tetramesh

---

```
d = [-1 1];
[x,y,z] = meshgrid(d,d,d); % a cube
x = [x(:);0];
y = [y(:);0];
z = [z(:);0];
```

[x,y,z] are corners of a cube plus the center.

```
DT = delaunayTriangulation(x,y,z);
tetramesh(DT);
camorbit(20,0)
```



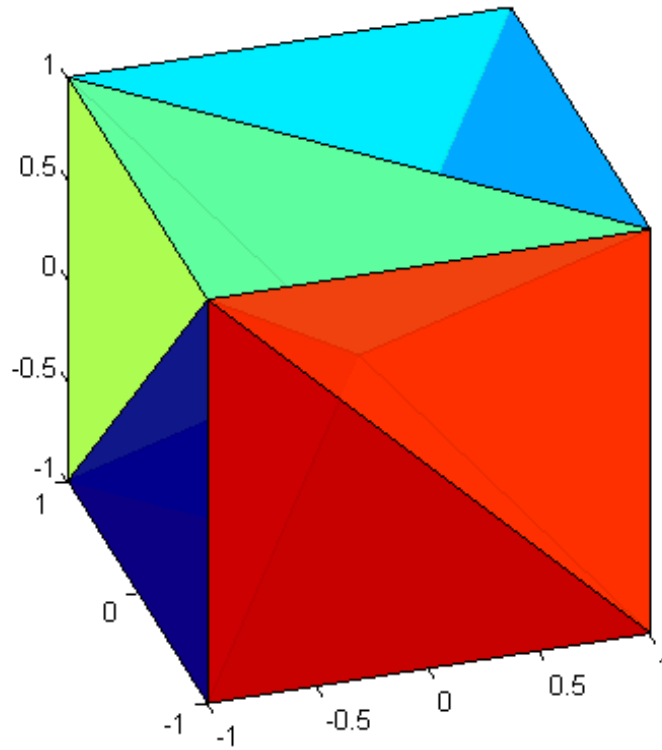

## See Also

[trimesh](#) | [trisurf](#) | [patch](#) | [delaunayn](#) | [triangulation](#) | [delaunayTriangulation](#) | [freeBoundary\(triangulation\)](#)

# matlab.unittest.Test

---

**Superclasses** TestSuite

**Purpose** Specification of a single test method

**Description** The matlab.unittest.Test class holds the information needed for the TestRunner object to be able to run a single Test method of a TestCase class. A scalar Test instance is the fundamental element contained in TestSuite arrays. A simple array of Test instances is a commonly used form of a TestSuite array.

## Properties

### Name

Name of the Test element.

### Parameterization

Row vector of parameters required for the Test. The Parameterization property contains all the parameterized data needed by the TestRunner.

### SharedTestFixtures

Row vector of fixtures required for the Test. The SharedTestFixtures property contains all the fixtures specified by the SharedTestFixtures class-level attribute of the TestCase class.

## Examples

### Show Class of a TestSuite Array

Create a suite of Test objects of all test methods in the BankAccountTest class.

```
import matlab.unittest.TestSuite;

suite = TestSuite.fromClass(?BankAccountTest);

whos suite
```

Name	Size	Bytes	Class	Attributes
------	------	-------	-------	------------

```
suite 1x5 1636 matlab.unittest.Test
```

Each test is a `matlab.unittest.Test` object.

Display test method names.

```
{suite.Name}'
```

```
ans =
```

```
'BankAccountTest/testConstructor'
'BankAccountTest/testConstructorNotEnoughInputs'
'BankAccountTest/testDesposit'
'BankAccountTest/testWithdraw'
'BankAccountTest/testNotifyInsufficientFunds'
```

## See Also

[matlab.unittest.TestSuite](#) | [matlab.unittest.TestRunner](#) |  
[matlab.unittest.TestCase](#) | [matlab.unittest.fixtures](#)

# matlab.unittest.TestCase

---

**Purpose** Superclass of all `matlab.unittest` test classes

**Description** The `TestCase` class is the means by which a test is written in the `matlab.unittest` framework. It provides the means to write and identify test content, as well as test fixture setup and teardown routines. Creating such a test requires deriving from `TestCase` to produce a `TestCase` subclass. Then, subclasses can leverage the metadata attributes to specify tests and test fixtures.

**Construction** The `TestCase` constructor is used to create `TestCase` instances intended for interactive, command line use. When tests are run in the framework, `TestCase` instances are constructed by the `matlab.unittest.TestRunner`.

## Methods

<code>addTeardown</code>	Dynamically add teardown routine
<code>applyFixture</code>	Use fixture with <code>TestCase</code>
<code>forInteractiveUse</code>	Create <code>TestCase</code> for interactive use
<code>getSharedTestFixtures</code>	Provide access to shared test fixtures
<code>run</code>	Run <code>TestCase</code> test

## Inherited Methods

The `TestCase` class inherits methods from the following classes:

<code>matlab.unittest.qualifications.Assertions</code>	Qualification to validate preconditions of a test
<code>matlab.unittest.qualifications.Assertions</code>	Qualification to filter test content

`matlab.unittest.qualifications.FatalQualification` Qualification to abort test execution

`matlab.unittest.qualifications.VerificationQualification` Qualification to produce soft-failure conditions

## Attributes

### Class Attributes

TestCase objects support the following class level attributes. Specify class-level attributes in the `classdef` block before the class name.

<code>SharedTestFixtures</code>	Class block to contain shared test fixtures. You must define <code>SharedTestFixtures</code> as a cell array of <code>matlab.unittest.fixtures.Fixture</code> instances.
---------------------------------	--------------------------------------------------------------------------------------------------------------------------------------------------------------------------

### Method Attributes

Classes that derive from `TestCase` can define `methods` blocks which contain `matlab.unittest` framework-specific attributes to specify test content.

<code>Test</code>	Method block to contain test methods.
<code>TestMethodSetup</code>	Method block to contain setup code.
<code>TestMethodTeardown</code>	Method block to contain teardown code.
<code>TestClassSetup</code>	Method block to contain class level setup code.

TestClassTeardown	Method block to contain class level teardown code.
ParameterCombination	Method block to contain parameterized testing code. This attribute accepts the following values: <ul style="list-style-type: none"><li>• 'exhaustive' (default): Test methods are invoked for all combinations of parameters.</li><li>• 'sequential': Test methods are invoked with corresponding values from each parameter. Each parameter must contain the same number of values.</li><li>• 'pairwise': Test methods are invoked for every pair of parameter values at least once.</li></ul>

## Property Attributes

Classes that derive from `TestCase` can define `properties` blocks which contain `matlab.unittest` framework-specific attributes to specify test content.

ClassSetupParameter	Property block to define parameterized testing properties for methods in the <code>TestClassSetup</code> block
MethodSetupParameter	Property block to define parameterized testing properties

for methods in the `MethodSetup` block

`TestParameter`

Property block to define parameterized testing properties for methods in the `Test` block

## Events

`AssertionFailed`

Triggered upon failing assertion. A `QualificationEventData` object is passed to listener callback functions.

`AssertionPassed`

Triggered upon passing assertion. A `QualificationEventData` object is passed to listener callback functions.

`AssumptionFailed`

Triggered upon failing assumption. A `QualificationEventData` object is passed to listener callback functions.

`AssumptionPassed`

Triggered upon passing assumption. A `QualificationEventData` object is passed to listener callback functions.

`FatalAssertionFailed`

Triggered upon failing fatal assertion. A `QualificationEventData` object is passed to listener callback functions.

# matlab.unittest.TestCase

---

FatalAssertionPassed	Triggered upon passing fatal assertion. A QualificationEventData object is passed to listener callback functions.
VerificationFailed	Triggered upon failing verification. A QualificationEventData object is passed to listener callback functions.
VerificationPassed	Triggered upon passing verification. A QualificationEventData object is passed to listener callback functions.
ExceptionThrown	Triggered by the TestRunner when an exception is thrown. An ExceptionEventData object is passed to listener callback functions.

## Examples

### Create Test Case Class

Create a test case class, `FigurePropertiesTest`, with `TestMethodSetup` and `TestMethodTeardown` methods.

```
classdef FigurePropertiesTest < matlab.unittest.TestCase

 properties
 TestFigure
 end

 methods(TestMethodSetup)
 function createFigure(testCase)
 testCase.TestFigure = figure;
 end
 end
end
```



```
 end
 end

 methods(TestMethodTeardown)
 function closeFigure(testCase)
 close(testCase.TestFigure);
 end
 end

 methods(Test)

 function defaultCurrentPoint(testCase)

 cp = get(testCase.TestFigure, 'CurrentPoint');
 testCase.verifyEqual(cp, [0 0], ...
 'Default current point is incorrect')
 end

 function defaultCurrentObject(testCase)
 import matlab.unittest.constraints.IsEmpty;

 co = get(testCase.TestFigure, 'CurrentObject');
 testCase.verifyThat(co, IsEmpty, ...
 'Default current object should be empty');
 end
 end

end

end
```

## See Also

[TestRunner](#) | [matlab.unittest.constraints](#) | [matlab.unittest.qualifications](#) | [addlistener](#) | [matlab.unittest.qualifications.QualificationEventData](#) | [matlab.unittest.qualifications.ExceptionEventData](#)

## Related Examples

- “Create Basic Parameterized Test”
- “Create Advanced Parameterized Test”

# matlab.unittest.TestCase

---

## Concepts

- “Method Attributes”
- “Class Attributes”

# matlab.unittest.TestCase.addTeardown

---

<b>Purpose</b>	Dynamically add teardown routine
<b>Syntax</b>	<code>addTeardown(testCase,tearDownFcn)</code> <code>addTeardown(testCase,tearDownFcn,arg1,...,argN)</code>
<b>Description</b>	<code>addTeardown(testCase,tearDownFcn)</code> adds the <code>tearDownFcn</code> function handle that defines fixture teardown code to the <code>testCase</code> instance. The teardown code is executed in the reverse order to which it is added. This is known as LIFO (or Last-In-First-Out). <code>addTeardown(testCase,tearDownFcn,arg1,...,argN)</code>
<b>Input Arguments</b>	<b>testCase</b> matlab.unittest.TestCase instance <b>tearDownFcn</b> Function, specified as a function handle, that defines the fixture teardown code <b>arg1,...,argN</b> Input arguments, 1 through N (if any), required by <code>tearDownFcn</code> , specified by any type. The argument type is specified by the function argument list.

## Examples **Call addTeardown in a TestMethodSetup Method**

```
classdef SomeTest < matlab.unittest.TestCase

 methods(TestMethodSetup)
 function createFixture(testCase)
 p = path;
 testCase.addTeardown(@path, p);
 addpath(fullfile(pwd, 'testHelpers'));
 end
 end
end
```

# matlab.unittest.TestCase.applyFixture

---

**Purpose** Use fixture with TestCase

**Syntax** `applyFixture(testCase, fixture)`

**Description** `applyFixture(testCase, fixture)` prepares the specified fixture for use with the TestCase. This method enables the use of a fixture within the scope of a single Test method or TestCase class. The life cycle of the fixture is tied to the TestCase. When the TestCase goes out of scope, the test framework tears down the fixture.

Call `applyFixture` within a Test method or TestMethodSetup method to use a fixture for the current test method alone. Use `applyFixture` within a TestClassSetup method to set up a fixture for the entire class.

## Input Arguments

### **testCase**

matlab.unittest.TestCase instance

### **fixture**

matlab.unittest.fixtures.Fixture instance

## Examples

### **Apply Fixtures to TestCase Class**

Create a temporary folder and make it the current working folder.

```
classdef applyFixtureTest < matlab.unittest.TestCase
 methods(TestMethodSetup)
 function addHelpers(testCase)
 import matlab.unittest.fixtures.TemporaryFolderFixture;
 import matlab.unittest.fixtures.CurrentFolderFixture;

 % Create a temporary folder and make it the current working
 % folder.
 tempFolder = testCase.applyFixture(TemporaryFolderFixture);
 testCase.applyFixture(CurrentFolderFixture(tempFolder.Folder));
 end
 end
end
```

Each test method can write files to the current working folder, which is the temporary folder. After each test method runs, the test framework restores the working folder to its previous state and deletes the temporary folder.

**See Also**

`matlab.unittest.fixtures`

# matlab.unittest.TestCase.forInteractiveUse

---

**Purpose** Create TestCase for interactive use

**Syntax** `tc = matlab.unittest.TestCase.forInteractiveUse`

**Description** `tc = matlab.unittest.TestCase.forInteractiveUse` creates a `TestCase` instance for interactive use. The `TestCase` is configured for experimentation at the command prompt. It reacts to qualification tests by printing messages to the screen for both passing and failing conditions.

## **Examples** **Verify Values Using Interactive TestCase**

Create a `TestCase` for interactive use.

```
import matlab.unittest.TestCase;
testCase = TestCase.forInteractiveUse;
```

Produce a passing verification.

```
testCase.verifyTrue(true, 'true should be true');
```

```
Interactive verification passed.
```

Produce a failing verification.

```
testCase.verifyTrue(false);
```

```
Interactive verification failed.
```

```

Framework Diagnostic:

verifyTrue failed.
--> The value must evaluate to "true".
```

```
Actual Value:
 0
```

# matlab.unittest.TestCase.forInteractiveUse

---

## See Also

[matlab.unittest.TestCase](#) | [matlab.unittest.qualifications](#)

# matlab.unittest.TestCase.getSharedTestFixtures

---

**Purpose** Provide access to shared test fixtures

**Syntax**

```
fixtures = getSharedTestFixtures(testCase)
fixtures = getSharedTestFixtures(testCase,fixtureClassName)
```

**Description**

`fixtures = getSharedTestFixtures(testCase)` provides access to the array of all shared test fixtures for `testCase`. `getSharedTestFixtures` returns an array of fixture objects, `fixtures`. Specify shared fixtures are using the `SharedTestFixtures` attribute for the `testCase` class.

`fixtures = getSharedTestFixtures(testCase,fixtureClassName)` returns only the shared fixtures that have the class name `fixtureClassName`.

**Input Arguments**

**testCase**  
matlab.unittest.TestCase instance

**fixtureClassName**  
Name of test fixture class, specified as a string

## Examples Obtain Array of All Shared Fixtures

Create the following class, `myTest`, on your MATLAB path. Two shared fixtures are used within the test method. This example assumes that the subfolder `helperFiles` exists in your working folder. Create the subfolder `helperFiles` in your working folder if it does not exist.

```
classdef (SharedTestFixtures={...
matlab.unittest.fixtures.PathFixture('helperFiles'),...
 matlab.unittest.fixtures.TemporaryFolderFixture}) ...
 myTest < matlab.unittest.TestCase
 methods(Test)
 function accessFixtures(testCase)
 myFixtures = testCase.getSharedTestFixtures
 end
 end
end
```



# matlab.unittest.TestCase.getSharedTestFixtures

---

```
end
```

At the command prompt, run the test.

```
run(myTest);
```

```
Setting up PathFixture.
```

```
Description: Adds 'H:\Documents\doc_examples\helperFiles' to the path.
```

---

```
Setting up TemporaryFolderFixture.
```

```
Description: Creates a temporary folder.
```

---

```
Running myTest
```

```
myFixtures =
```

```
 1x2 heterogeneous Fixture (PathFixture, TemporaryFolderFixture) array
```

```
.
```

```
Done myTest
```

---

```
Tearing down TemporaryFolderFixture.
```

```
Description: Deletes the temporary folder and all its contents.
```

---

```
Tearing down PathFixture.
```

```
Description: Restores the path to its previous state.
```

---

## Access Shared Fixtures of Particular Class

Create the class, `mySecondTest`, on your MATLAB path.

```
classdef (SharedTestFixtures={...
 matlab.unittest.fixtures.TemporaryFolderFixture})...
```

# matlab.unittest.TestCase.getSharedTestFixtures

---

```
 mySecondTest < matlab.unittest.TestCase
 methods(Test)
 function accessTemporaryFolderFixture(testCase)
 tempFolderFixture = testCase.getSharedTestFixtures...
 ('matlab.unittest.fixtures.TemporaryFolderFixture');
 temporaryFolder = tempFolderFixture.Folder
 end
 end
end
```

At the command prompt, run the test. The name of the temporary folder varies.

```
run(mySecondTest);
```

```
Setting up TemporaryFolderFixture.
Description: Creates a temporary folder.
```

```
Running mySecondTest
```

```
temporaryFolder =
```

```
C:\Temp\tpb92c9c67_02fa_4714_bfb0_b2127df0f31d
```

```
.
Done mySecondTest
```

```
Tearing down TemporaryFolderFixture.
Description: Deletes the temporary folder and all its contents.
```

## See Also

[matlab.unittest.TestCase](#) | [matlab.unittest.fixtures](#)

## Concepts

- Class Attributes

## Purpose

Run `TestCase` test

## Syntax

```
result = run(testCase)
result = run(testCase, testMethod)
```

## Description

`result = run(testCase)` uses `testCase` as a prototype to run a `TestSuite` array created from all test methods in the class defining `testCase`. This suite is run using a `TestRunner` object configured for text output.

`result = run(testCase, testMethod)` uses `testCase` as a prototype to run a `TestSuite` array created from `testMethod`. This test is run using a `TestRunner` object configured for text output.

This is a convenience method to allow interactive experimentation of `TestCase` classes in MATLAB, yet running the tests contained in them using a supported `TestRunner` object.

## Input Arguments

### **testCase**

`matlab.unittest.TestCase` instance

### **testMethod**

Name of desired test method, specified as one of the following:

- string
- `meta.method` instance

The method must correspond to a valid Test method of the `testCase` instance.

## Output Arguments

### **result**

A `matlab.unittest.TestResult` object containing the result of the test run.

## Examples

### Run Test Directly from Test Case

Add the FigurePropertiesTest.m test case file to a folder on your MATLAB path.

```
classdef FigurePropertiesTest < matlab.unittest.TestCase

 properties
 TestFigure
 end

 methods(TestMethodSetup)
 function createFigure(testCase)
 %comment
 testCase.TestFigure = figure;
 end
 end

 methods(TestMethodTeardown)
 function closeFigure(testCase)
 close(testCase.TestFigure);
 end
 end

 methods(Test)

 function defaultCurrentPoint(testCase)

 cp = get(testCase.TestFigure, 'CurrentPoint');
 testCase.verifyEqual(cp, [0 0], ...
 'Default current point is incorrect')
 end

 function defaultCurrentObject(testCase)
 import matlab.unittest.constraints.IsEmpty;

 co = get(testCase.TestFigure, 'CurrentObject');
```

```
 testCase.verifyThat(co, IsEmpty, ...
 'Default current object should be empty');
 end
```

```
end
```

```
end
```

Create a testcase object.

```
tc = FigurePropertiesTest;
```

Run the tests.

```
tc.run;
```

```
Running FigurePropertiesTest
```

```
..
```

```
Done FigurePropertiesTest
```

---

All tests passed.

## See Also

[matlab.unittest.TestSuite.run](#) |  
[matlab.unittest.TestRunner.run](#)

# matlab.unittest.TestResult

---

**Purpose** Result of running test suite

**Description** The `matlab.unittest.TestResult` class holds the information describing the result of running a test suite using the `matlab.unittest` framework. The results include information describing whether the test passed, failed, or ran to completion, as well as the duration of each test.

**Construction** `TestResult` arrays are created and returned by the test runner, and are of the same size as the suite which was run.

## Properties

### Duration

Time elapsed running test.

The `Duration` property indicates the amount of time taken to run a particular test, including the time taken setting up and tearing down any test fixtures.

Fixture setup time is accounted for in the duration of the first test suite array element that uses the fixture. Fixture teardown time is accounted for in the duration of the last test suite array element that uses the fixture.

The total run time for a suite of tests exceeds the sum of the durations for all the elements of the suite because the `Duration` property does not include all the overhead of the `TestRunner` object, nor any of the time consumed by test runner plugins.

### Failed

Logical value showing if test failed.

A `TRUE Failed` property indicates some form of test failure. When `Failed` is `FALSE`, then no failing conditions were encountered. A failing result can occur with a failure condition either in a test or in setting up and tearing down test fixtures. Failures can occur due to the following:

- Verification failures

- Assertion failures
- Uncaught MExceptions

Fatal assertions are also failing conditions, but in the event of a fatal assertion failure, the entire framework aborts and a `TestResult` object is never produced.

## **Incomplete**

Logical value showing if test did not run to completion.

A `TRUE` `Incomplete` property indicates a test did not run to completion. When it is `FALSE`, then no conditions were encountered that prevented the test from completing. In other words, when `FALSE` there were no stack disruptions out of the running test content. An incomplete result can occur with a stack disruption in either a test or when setting up and tearing down test fixtures. Incomplete tests can occur due to the following:

- Assertion failures
- Tests filtered through assumption
- Uncaught MExceptions

Fatal assertions are also conditions that prevent the completion of tests, but in the event of a fatal assertion failure the entire framework aborts and a `TestResult` object is never produced.

## **Name**

The name of the `TestSuite` object for the result.

The `Name` property is a string that holds the name of the test corresponding to this result.

## **Passed**

Logical value showing if the test passed.

# matlab.unittest.TestResult

---

When the `Passed` property is `TRUE`, then the test completed as expected without any failure. When it is `FALSE`, then the test did not run to completion and/or encountered a failure condition.

## Examples

### Use TestResult Object to Identify and Rerun Failed Tests

Add the `matlab.unittest.TestSuite` class to the current import list.

```
import matlab.unittest.TestSuite;
```

Result display method provides a summary of the results

```
suite = TestSuite.fromClass(?SomeTestClass)
results = run(suite)
```

```
results =
```

```
 matlab.unittest.TestResult
```

```
 Test Suite Summary:
```

```
 12 Passed, 4 Failed, 0 Not Run To Completion.
```

```
 5.5091 seconds testing time.
```

Rerun only the failed tests.

```
failedTests = suite([results.Failed]);
failedResults = run(failedTests)
```

```
failedResults =
```

```
 matlab.unittest.TestResult
```

```
 Test Suite Summary:
```

```
 0 Passed, 4 Failed, 0 Not Run To Completion.
```

```
 1.2894 seconds testing time.
```

Make the fix and rerun results.



```
newResults = run(failedTests)

newResults =

 matlab.unittest.TestResult

Test Suite Summary:
 4 Passed, 0 Failed, 0 Not Run To Completion.
 1.1607 seconds testing time.
```

## See Also

[TestRunner](#) | [TestSuite](#)

## Concepts

- [Property Attributes](#)

# matlab.unittest.TestRunner

---

**Purpose** Class for running tests in `matlab.unittest` framework

**Description** The `matlab.unittest.TestRunner` class is the fundamental API used to run a suite of tests in the `matlab.unittest` framework. It runs and operates on `TestSuite` arrays. Use this class to customize running tests. The `TestRunner` class is a sealed class; you cannot derive classes from the `TestRunner` class.

**Construction** To create a simple, silent `TestRunner` object, call the static `withNoPlugins` method.

```
runner = matlab.unittest.TestRunner.withNoPlugins
```

To create a `TestRunner` object to run tests from the MATLAB Command Window , call the static `withTextOutput` method.

```
runner = matlab.unittest.TestRunner.withTextOutput
```

To create a customized `TestRunner` object, call the `addPlugin` method.

```
runner = TestRunner.withNoPlugins;
runner.addPlugin(SomePlugin())
```

<b>Methods</b>		
<code>addPlugin</code>		Add plugin to <code>TestRunner</code> object
<code>run</code>		Run all tests in <code>TestSuite</code> array
<code>withNoPlugins</code>		Create simplest runner possible
<code>withTextOutput</code>		Create <code>TestRunner</code> object for command window output

## **Examples** **Create TestRunner Object Configured for Text Output**

Add `matlab.unittest` classes to the current import list.

```
import matlab.unittest.TestRunner;
```

```
import matlab.unittest.TestSuite;
```

Create a TestSuite array.

```
suite = TestSuite.fromClass(?mypackage.MyTestClass);
```

Create the TestRunner object and run the suite.

```
runner = TestRunner.withTextOutput;
result = run(runner,suite);
```

## See Also

[TestSuite](#) | [TestResult](#)

# matlab.unittest.TestRunner.addPlugin

---

<b>Purpose</b>	Add plugin to TestRunner object
<b>Syntax</b>	<code>addPlugin(runner,plugin)</code>
<b>Description</b>	<code>addPlugin(runner,plugin)</code> adds plugin to runner.
<b>Input Arguments</b>	<b>runner</b> matlab.unittest.TestRunner object. <b>plugin</b> Mechanism provided to customize the manner in which a TestSuite array is run, specified as a TestRunnerPlugin object.

## Examples **Run Test with Custom Plugin**

Add matlab.unittest classes to the current import list.

```
import matlab.unittest.TestRunner;
import matlab.unittest.TestSuite;
```

Create a TestSuite array.

```
suite = TestSuite.fromClass(?mypackage.MyTestClass);
```

Create a TestRunner object.

```
runner = TestRunner.withNoPlugins;
```

Add a custom plugin.

```
import matlab.unittest.plugins.DiagnosticsValidationPlugin;
runner.addPlugin(DiagnosticsValidationPlugin);
```

Run the test.

```
result = run(runner,suite);
```

<b>Purpose</b>	Run all tests in <code>TestSuite</code> array
<b>Syntax</b>	<code>result = run(runner,suite)</code>
<b>Description</b>	<p><code>result = run(runner,suite)</code> runs the <code>TestSuite</code> array defined by <code>suite</code> using the <code>TestRunner</code> object provided in <code>runner</code>, and returns the result in <code>result</code>.</p> <p>This method runs all of the appropriate methods of the <code>TestCase</code> class to set up fixtures and run test content. It handles errors and qualification failures and records the information in <code>result</code>.</p>
<b>Input Arguments</b>	<p><b>runner</b> matlab.unittest.TestRunner object.</p> <p><b>suite</b> Set of tests, specified as a matlab.unittest.TestSuite array.</p>
<b>Output Arguments</b>	<p><b>result</b> A matlab.unittest.TestResult object containing the result of the test run. <code>result</code> is the same size as <code>suite</code> and each element is the result of the corresponding element in <code>suite</code>.</p>
<b>Examples</b>	<p><b>Run All Tests in a Package</b></p> <p>Add matlab.unittest classes to the current import list.</p> <pre>import matlab.unittest.TestRunner; import matlab.unittest.TestSuite;</pre> <p>Create a test suite, and a test runner that displays text.</p> <pre>suite = TestSuite.fromClass(?mypackage.MyTestClass); runner = TestRunner.withTextOutput;</pre> <p>Run the test suite.</p>

# matlab.unittest.TestRunner.run

---

```
result = runner.run(suite)
```

## See Also

[matlab.unittest.TestSuite.run](#) | [matlab.unittest.TestCase.run](#)

# matlab.unittest.TestRunner.withNoPlugins

---

<b>Purpose</b>	Create simplest runner possible		
<b>Syntax</b>	<code>runner = matlab.unittest.TestRunner.withNoPlugins</code>		
<b>Description</b>	<p><code>runner = matlab.unittest.TestRunner.withNoPlugins</code> creates a <code>TestRunner</code> that is guaranteed to have no plugins installed and returns it in <code>runner</code>. It is the method one can use to create the simplest runner possible without violating the guarantees a test writer has when writing <code>TestCase</code> classes. This runner is a silent runner, meaning that regardless of passing or failing tests, this runner produces no command window output, although the results returned after running a test suite are accurate.</p> <p>This method can also be used when it is desirable to have complete control over which plugins are installed and in what order. It is the only method guaranteed to produce the minimal <code>TestRunner</code> with no plugins, so one can create it and add additional plugins as desired.</p>		
<b>Output Arguments</b>	<p><b>runner</b> matlab.unittest.TestRunner object.</p>		
<b>Attributes</b>	<table><tr><td>Static</td><td>true</td></tr></table> <p>To learn about attributes of methods, see <a href="#">Method Attributes</a> in the <a href="#">MATLAB Object-Oriented Programming</a> documentation.</p>	Static	true
Static	true		
<b>Examples</b>	<p><b>Create a Silent TestRunner Object with no Plugins</b></p> <p>Add <code>matlab.unittest</code> classes to the current import list.</p> <pre>import matlab.unittest.TestRunner; import matlab.unittest.TestSuite;</pre> <p>Create a <code>TestSuite</code> array.</p> <pre>suite = TestSuite.fromClass(?mypackage.MyTestClass);</pre>		

# matlab.unittest.TestRunner.withNoPlugins

---

Create a TestRunner object.

```
runner = TestRunner.withNoPlugins;

% Run the suite silently
result = run(runner,suite)
```

## Control Plugins

Using the TestRunner object created in the previous example, control which plugins are installed and in what order they are installed.

Add matlab.unittest class to the current import list.

```
import matlab.unittest.plugins;
```

Add specific plugins.

```
runner.addPlugin(DiagnosticsValidationPlugin);
runner.addPlugin(TestSuiteProgressPlugin);
```

Rerun the tests.

```
result = run(runner,suite)
```



# matlab.unittest.TestRunner.withTextOutput

---

<b>Purpose</b>	Create TestRunner object for command window output
<b>Syntax</b>	<code>runner = matlab.unittest.TestRunner.withTextOutput</code>
<b>Description</b>	<code>runner = matlab.unittest.TestRunner.withTextOutput</code> creates a TestRunner object that is configured for running tests from the MATLAB Command Window and returns it in <code>runner</code> . The output produced includes test progress as well as diagnostics in the event of test failures.
<b>Output Arguments</b>	<b>runner</b> matlab.unittest.TestRunner object.
<b>Attributes</b>	Static <span style="float: right;">true</span>  To learn about attributes of methods, see Method Attributes in the MATLAB Object-Oriented Programming documentation.
<b>Examples</b>	<b>Display Test Results in Command Window</b>  Add matlab.unittest classes to the current import list.  <pre>import matlab.unittest.TestRunner; import matlab.unittest.TestSuite;</pre> Create a TestSuite array.  <pre>suite = TestSuite.fromClass(?mypackage.MyTestClass);</pre> Create a TestRunner object that produced output to the Command Window.  <pre>runner = TestRunner.withTextOutput;</pre> <pre>% Run the suite</pre>

# matlab.unittest.TestRunner.withTextOutput

---

```
result = run(runner,suite)
```

**See Also** [run](#)

<b>Purpose</b>	Class for grouping tests to run																
<b>Description</b>	The <code>matlab.unittest.TestSuite</code> class is the fundamental interface used to group and run a set of tests in the unit test framework. The <code>matlab.unittest.TestRunner</code> object can only run arrays of <code>TestSuite</code> objects.																
<b>Construction</b>	<code>TestSuite</code> arrays are created using static methods of the <code>TestSuite</code> class. These methods may return subclasses of the <code>TestSuite</code> class depending on the method call and context.																
<b>Methods</b>	<table><tr><td><code>fromClass</code></td><td>Create suite from <code>TestCase</code> class</td></tr><tr><td><code>fromFile</code></td><td>Create <code>TestSuite</code> array from test file</td></tr><tr><td><code>fromFolder</code></td><td>Create <code>TestSuite</code> array from all tests in folder</td></tr><tr><td><code>fromMethod</code></td><td>Create <code>TestSuite</code> array from single test method</td></tr><tr><td><code>fromName</code></td><td>Create <code>Test</code> object from name of test element</td></tr><tr><td><code>fromPackage</code></td><td>Create <code>TestSuite</code> array from all tests in package</td></tr><tr><td><code>run</code></td><td>Run <code>TestSuite</code> array using <code>TestRunner</code> object configured for text output</td></tr><tr><td><code>selectIf</code></td><td>Select test suite elements that satisfy conditions</td></tr></table>	<code>fromClass</code>	Create suite from <code>TestCase</code> class	<code>fromFile</code>	Create <code>TestSuite</code> array from test file	<code>fromFolder</code>	Create <code>TestSuite</code> array from all tests in folder	<code>fromMethod</code>	Create <code>TestSuite</code> array from single test method	<code>fromName</code>	Create <code>Test</code> object from name of test element	<code>fromPackage</code>	Create <code>TestSuite</code> array from all tests in package	<code>run</code>	Run <code>TestSuite</code> array using <code>TestRunner</code> object configured for text output	<code>selectIf</code>	Select test suite elements that satisfy conditions
<code>fromClass</code>	Create suite from <code>TestCase</code> class																
<code>fromFile</code>	Create <code>TestSuite</code> array from test file																
<code>fromFolder</code>	Create <code>TestSuite</code> array from all tests in folder																
<code>fromMethod</code>	Create <code>TestSuite</code> array from single test method																
<code>fromName</code>	Create <code>Test</code> object from name of test element																
<code>fromPackage</code>	Create <code>TestSuite</code> array from all tests in package																
<code>run</code>	Run <code>TestSuite</code> array using <code>TestRunner</code> object configured for text output																
<code>selectIf</code>	Select test suite elements that satisfy conditions																

## Examples **Create Test Suite of Every Type of Test Set**

Add the `matlab.unittest.TestSuite` class to the current import list.

# matlab.unittest.TestSuite

---

```
import matlab.unittest.TestSuite;
```

Create test suites using a each method.

```
fileSuite = TestSuite.fromFile('SomeTestFile.m');
folderSuite = TestSuite.fromFolder(pwd);
packageSuite = TestSuite.fromPackage('mypackage.subpackage');
classSuite = TestSuite.fromClass(?mypackage.MyTestClass);
methodSuite = TestSuite.fromMethod(?SomeTestClass,'testMethod');
```

Concatenate the suites.

```
largeSuite = [fileSuite, folderSuite, packageSuite, classSuite, methodSuite];
```

Run the full suite.

```
result = run(largeSuite)
```

## See Also

[TestRunner](#) | [TestResult](#) | [Test](#)

## Purpose

Create suite from TestCase class

## Syntax

```
suite = matlab.unittest.TestSuite.fromClass(testClass)
suite = matlab.unittest.TestSuite.fromClass(testClass,s)
suite = matlab.unittest.TestSuite.fromClass(___,Name,Value)
```

## Description

`suite = matlab.unittest.TestSuite.fromClass(testClass)` creates a TestSuite array from all of the Test methods contained in `testClass` and returns that array in `suite`.

`suite = matlab.unittest.TestSuite.fromClass(testClass,s)` creates a TestSuite array from all of the Test methods contained in `testClass` that satisfy the conditions specified by the selector, `s`.

`suite = matlab.unittest.TestSuite.fromClass( ___,Name,Value)` creates a TestSuite array with additional options specified by one or more `Name,Value` pair arguments. You can use this syntax with any of the input arguments of the previous syntaxes.

## Tips

- `testClass` must be on the MATLAB path when using this method to create `suite`, as well as when `suite` is run.

## Input Arguments

### **testClass**

Class containing test methods, specified as a `meta.class` instance. Use the `?` operator to create a `meta.class` instance. `testClass` must derive from `matlab.unittest.TestCase`.

### **s**

Selector, specified as an instance of a class from the `matlab.unittest.selector` package.

## Name-Value Pair Arguments

### **'Name'**

# matlab.unittest.TestSuite.fromClass

---

String indicating the name of the suite element. To include a test element in the suite, the `Name` property of the test element must match the specified name. Use the wildcard character, `*`, to match any number of characters. Use the question mark character, `?`, to match to exactly one character.

## **'ParameterProperty'**

String indicating the name of a property that defines a parameter used by the test suite element. Use the wildcard character, `*`, to match any number of characters. Use the question mark character, `?`, to match to exactly one character.

## **'ParameterName'**

String indicating the name of a parameter used by the test suite element. Use the wildcard character, `*`, to match any number of characters. Use the question mark character, `?`, to match to exactly one character.

## **'BaseFolder'**

String indicating the name of the folder that contains the file defining the test class or function. For a test element to be included in the suite, the test element must be contained in the specified base folder. Use the wildcard character, `*`, to match any number of characters. Use the question mark character, `?`, to match to exactly one character. For test classes defined in packages, the base folder is the parent of the top-level package folder.

## **Output Arguments**

**suite**

Set of tests, specified as a `matlab.unittest.Test` array.

## **Attributes**

Static

true

To learn about attributes of methods, see [Method Attributes in the MATLAB Object-Oriented Programming documentation](#).

## Examples

### Run Tests in a Package Class

Add the `matlab.unittest.TestSuite` class to the current import list.

```
import matlab.unittest.TestSuite;

suite = TestSuite.fromClass(?mypackage.MyTestClass);
result = run(suite)
```

### Run Tests in a Class Without a Package

Add the `matlab.unittest.TestSuite` class to the current import list.

```
import matlab.unittest.TestSuite;

suite = TestSuite.fromClass(?MyTestClass);
result = run(suite)
```

### Create Suite of Test Elements Using Selector

In your working folder, create the following `testZeros.m` test file. This class contains four test methods.

```
classdef testZeros < matlab.unittest.TestCase
 properties (TestParameter)
 type = {'single','double','uint16'};
 outSize = struct('s2d',[3 3], 's3d',[2 5 4]);
 end

 methods (Test)
 function testClass(testCase, type, outSize)
 testCase.verifyClass(zeros(outSize,type), type);
 end

 function testSize(testCase, outSize)
 testCase.verifySize(zeros(outSize), outSize);
 end

 function testDefaultClass(testCase)
```

# matlab.unittest.TestSuite.fromClass

---

```
 testCase.verifyClass(zeros, 'double');
 end
 function testDefaultSize(testCase)
 testCase.verifySize(zeros, [1 1]);
 end

 function testDefaultValue(testCase)
 testCase.verifyEqual(zeros,0);
 end
end
end
```

The test class contains two parameterized test methods, `testClass` and `testSize`.

At the command prompt, create a test suite from the test elements that tests the 'double' data type.

```
import matlab.unittest.TestSuite;
import matlab.unittest.selectors.HasParameter;

suite = TestSuite.fromClass(?testZeros, ...
 HasParameter('Property','type','Name','double'));
{suite.Name}'

ans =

 'testZeros/testClass(type=double,outSize=s2d)'
 'testZeros/testClass(type=double,outSize=s3d)'
```

## Create Suite of Test Elements Using Name-Value Arguments

Create the `testZeros.m` class from the previous example.

At the command prompt, create a test suite from the test elements that tests the 'double' data type.

```
import matlab.unittest.TestSuite;
```



```
suite = TestSuite.fromClass(?testZeros, ...
 'ParameterProperty','type', 'ParameterName','double');
{suite.Name}'

ans =

 'testZeros/testClass(type=double,outSize=s2d)'
 'testZeros/testClass(type=double,outSize=s3d)'
```

## See Also

TestRunner | fromMethod | fromPackage |  
matlab.unittest.selectors

# matlab.unittest.TestSuite.fromFile

---

**Purpose** Create TestSuite array from test file

**Syntax**

```
suite = matlab.unittest.TestSuite.fromFile(file)
suite = matlab.unittest.TestSuite.fromFile(file,s)
suite = matlab.unittest.TestSuite.fromFile(___,Name,Value)
```

**Description** `suite = matlab.unittest.TestSuite.fromFile(file)` creates a TestSuite array from all of the Test methods in `file`.

When the test suite is run, MATLAB changes the current folder to the folder that defines the test content, and adds it to the path for the duration of the test run.

`suite = matlab.unittest.TestSuite.fromFile(file,s)` creates a TestSuite array from all of the Test methods in `file` that satisfy the conditions specified by the selector, `s`.

`suite = matlab.unittest.TestSuite.fromFile(___,Name,Value)` creates a TestSuite array with additional options specified by one or more `Name,Value` pair arguments. You can use this syntax with any of the input arguments of the previous syntaxes.

## Input Arguments

### **file**

Class file derived from `matlab.unittest.TestCase` containing test methods, specified as a string.

### **s**

Selector, specified as an instance of a class from the `matlab.unittest.selector` package.

## **Name-Value Pair Arguments**

Specify optional comma-separated pairs of `Name,Value` arguments. `Name` is the argument name and `Value` is the corresponding value. `Name` must appear inside single quotes (`' '`). You can

specify several name and value pair arguments in any order as `Name1, Value1, ..., NameN, ValueN`.

## **'Name'**

String indicating the name of the suite element. To include a test element in the suite, the `Name` property of the test element must match the specified name. Use the wildcard character, `*`, to match any number of characters. Use the question mark character, `?`, to match to exactly one character.

## **'ParameterProperty'**

String indicating the name of a property that defines a parameter used by the test suite element. Use the wildcard character, `*`, to match any number of characters. Use the question mark character, `?`, to match to exactly one character.

## **'ParameterName'**

String indicating the name of a parameter used by the test suite element. Use the wildcard character, `*`, to match any number of characters. Use the question mark character, `?`, to match to exactly one character.

## **'BaseFolder'**

String indicating the name of the folder that contains the file defining the test class or function. For a test element to be included in the suite, the test element must be contained in the specified base folder. Use the wildcard character, `*`, to match any number of characters. Use the question mark character, `?`, to match to exactly one character. For test classes defined in packages, the base folder is the parent of the top-level package folder.

## **Output Arguments**

### **suite**

Set of tests, specified as a `matlab.unittest.Test` array.

# matlab.unittest.TestSuite.fromFile

---

## Attributes

Static

true

To learn about attributes of methods, see Method Attributes in the MATLAB Object-Oriented Programming documentation.

## Examples

### Run Tests in Class File

Function for unit testing:

```
function res = add5(x)
%ADD5 Increment input by 5.
if ~isa(x,'numeric')
 error('add5:InputMustBeNumeric','Input must be numeric.');
```

TestCase class containing test methods:

```
classdef Add5Test < matlab.unittest.TestCase
 methods (Test)
 function testDoubleOut(testCase)
 actOutput = add5(1);
 testCase.verifyClass(actOutput,'double');
 end
 function testNonNumericInput(testCase)
 testCase.verifyError(@()add5('0'),'add5:InputMustBeNumeric');
 end
 end
end
```

Create a test suite from the Add5Test class file.

```
suite = matlab.unittest.TestSuite.fromFile('Add5Test.m');
result = run(suite);
```

```
Running Add5Test
..
Done Add5Test
```

---

## Create Suite of Test Elements Using Selector

In your working folder, create `testZeros.m`. This class contains four test methods.

```
classdef testZeros < matlab.unittest.TestCase
 properties (TestParameter)
 type = {'single','double','uint16'};
 outSize = struct('s2d',[3 3], 's3d',[2 5 4]);
 end

 methods (Test)
 function testClass(testCase, type, outSize)
 testCase.verifyClass(zeros(outSize,type), type);
 end

 function testSize(testCase, outSize)
 testCase.verifySize(zeros(outSize), outSize);
 end

 function testDefaultClass(testCase)
 testCase.verifyClass(zeros, 'double');
 end
 function testDefaultSize(testCase)
 testCase.verifySize(zeros, [1 1]);
 end

 function testDefaultValue(testCase)
 testCase.verifyEqual(zeros,0);
 end
 end
end
```

# matlab.unittest.TestSuite.fromFile

---

The test class contains two parameterized test methods, `testClass` and `testSize`.

At the command prompt, create a test suite from all parameterized test methods in `testZeros.m` using the `HasParameter` selector.

```
import matlab.unittest.TestSuite;
import matlab.unittest.selectors.HasParameter;

suite = TestSuite.fromFile('testZeros.m', HasParameter)
```

```
suite =
```

```
 1x8 Test array with properties:
```

```
 Name
 Parameterization
 SharedTestFixtures
```

Create a test suite from only the test elements from the `testSize` method using the `HasName` selector with the `StartsWithSubstring` constraint.

```
import matlab.unittest.selectors.HasName;
import matlab.unittest.constraints.StartsWithSubstring;

suite = TestSuite.fromFile('testZeros.m',...
 HasName(StartsWithSubstring('testZeros/testSize')));
{suite.Name}'
```

```
ans =
```

```
 'testZeros/testSize(outSize=s2d) '
 'testZeros/testSize(outSize=s3d) '
```

The test suite contains the two parameterized tests from the `testSize` method.

## Create Suite of Test Elements Using Name-Value Arguments

Create the `testZeros.m` class from the previous example.

At the command prompt, create a test suite from all test methods in `testZeros.m` that have a name starting with `'testZeros/testSize'`. This test suite contains parameterized tests from the `testSize` method.

```
import matlab.unittest.TestSuite;

suite = TestSuite.fromFile('testZeros.m', 'Name', 'testZeros/testSize',
{suite.Name})

ans =

 'testZeros/testSize(outSize=s2d)'
 'testZeros/testSize(outSize=s3d)'
```

To ensure that a test suite is comprised of test elements associated with one particular test method, use the `fromMethod` method of `TestSuite`.

At the command prompt, create a test suite from all test methods in `testZeros.m` that have a name ending in `'Size'`.

```
import matlab.unittest.TestSuite;

suite = TestSuite.fromFile('testZeros.m', 'Name', '*Size');
{suite.Name}

ans =

 'testZeros/testDefaultSize'
```

Note that elements from the `testSize` method are not included in the test suite. The name of these elements contains information about the parameterization, and therefore it does not end with `'Size'`.

Create a test suite of all tests that use the parameter name `'double'`.

# matlab.unittest.TestSuite.fromFile

---

```
suite = TestSuite.fromFile('testZeros.m', 'ParameterName', 'double');
{suite.Name}'
```

```
ans =
```

```
 'testZeros/testClass(type=double,outSize=s2d)'
 'testZeros/testClass(type=double,outSize=s3d)'
```

To construct the same test suite using selectors,  
use `suite = TestSuite.fromFile('testZeros.m',  
HasParameter('Name','double'))`.

## See Also

[TestRunner](#) | [fromFolder](#) | [matlab.unittest.selectors](#)



## Purpose

Create TestSuite array from all tests in folder

## Syntax

```
suite = matlab.unittest.TestSuite.fromFolder(folder)
suite = matlab.unittest.TestSuite.fromFolder(folder,s)
suite =
matlab.unittest.TestSuite.fromFolder(___,Name,Value)
```

## Description

`suite = matlab.unittest.TestSuite.fromFolder(folder)` creates a TestSuite array from all of the Test methods of all concrete TestCase classes contained in `folder` and returns that array in `suite`. If tests are function-based, a Test file is included in the TestSuite array if it follows the naming convention of starting or ending in the word 'test', which is case-insensitive. Class-based tests do not need to follow this naming convention. The method is not recursive, returning only those tests directly in the specified folder.

When the test suite is run, MATLAB changes the current folder to the folder that defines the test content, and adds it to the path for the duration of the test run.

`suite = matlab.unittest.TestSuite.fromFolder(folder,s)` creates a TestSuite array from all of the Test methods contained in `folder` that satisfy the conditions specified by the selector, `s`.

`suite = matlab.unittest.TestSuite.fromFolder( ___,Name,Value)` creates a TestSuite array with additional options specified by one or more `Name,Value` pair arguments. You can use this syntax with any of the input arguments of the previous syntaxes.

## Input Arguments

### folder

Folder containing test methods, specified as a string. `folder` can be either an absolute or relative path to the desired folder.

**s**

# matlab.unittest.TestSuite.fromFolder

---

Selector, specified as an instance of a class from the `matlab.unittest.selector` package.

## **Name-Value Pair Arguments**

### **'IncludingSubfolders'**

Include test methods from any `folder` subfolders, excluding package, class, and private folders. This property is `false` by default. You can specify it as `true` during construction.

### **'Name'**

String indicating the name of the suite element. To include a test element in the suite, the `Name` property of the test element must match the specified name. Use the wildcard character, `*`, to match any number of characters. Use the question mark character, `?`, to match to exactly one character.

### **'ParameterProperty'**

String indicating the name of a property that defines a parameter used by the test suite element. Use the wildcard character, `*`, to match any number of characters. Use the question mark character, `?`, to match to exactly one character.

### **'ParameterName'**

String indicating the name of a parameter used by the test suite element. Use the wildcard character, `*`, to match any number of characters. Use the question mark character, `?`, to match to exactly one character.

### **'BaseFolder'**

String indicating the name of the folder that contains the file defining the test class or function. For a test element to be included in the suite, the test element must be contained in the specified base folder. Use the wildcard character, `*`, to match any number of characters. Use the question mark character, `?`, to match to exactly one character. For test classes defined in

packages, the base folder is the parent of the top-level package folder.

## Output Arguments

**suite**

Set of tests, specified as a `matlab.unittest.Test` array.

## Attributes

Static

true

To learn about attributes of methods, see [Method Attributes in the MATLAB Object-Oriented Programming documentation](#).

## Examples

### Run Tests in Current Folder

Add the `matlab.unittest.TestSuite` class to the current import list.

```
import matlab.unittest.TestSuite;

suite = TestSuite.fromFolder(pwd);
result = run(suite);
```

### Run Tests in Subfolders

```
suite = TestSuite.fromFolder(pwd, 'IncludingSubfolders', true);
result = run(suite);
```

### Create Suite of Test Elements Using Selector

In your working folder, create a new folder, `myTests`. In that folder, create the following `testZeros.m` test file. This class contains four test methods.

```
classdef testZeros < matlab.unittest.TestCase
 properties (TestParameter)
 type = {'single','double','uint16'};
 outSize = struct('s2d',[3 3], 's3d',[2 5 4]);
 end
```

# matlab.unittest.TestSuite.fromFolder

---

```
methods (Test)
 function testClass(testCase, type, outSize)
 testCase.verifyClass(zeros(outSize,type), type);
 end

 function testSize(testCase, outSize)
 testCase.verifySize(zeros(outSize), outSize);
 end

 function testDefaultClass(testCase)
 testCase.verifyClass(zeros, 'double');
 end
 function testDefaultSize(testCase)
 testCase.verifySize(zeros, [1 1]);
 end

 function testDefaultValue(testCase)
 testCase.verifyEqual(zeros,0);
 end
end
end
```

The test class contains two parameterized test methods, `testClass` and `testSize`.

At the command prompt, create a test suite from all parameterized tests that use the parameter name 'double'.

```
import matlab.unittest.TestSuite;
import matlab.unittest.selectors.HasParameter;

suite = TestSuite.fromFolder('myTests', HasParameter('Name','double'));
{suite.Name}'

ans =

 'testZeros/testClass(type=double,outSize=s2d)'
 'testZeros/testClass(type=double,outSize=s3d)'
```

## Create Suite of Test Elements Using Name-Value Arguments

Create the `myTests` folder and `testZeros.m` class from the previous example.

Create a test suite of all tests that use the parameter name `'double'`.

```
import matlab.unittest.TestSuite;

suite = TestSuite.fromFolder('myTests', 'ParameterName', 'double');
{suite.Name}'

ans =

 'testZeros/testClass(type=double,outSize=s2d) '
 'testZeros/testClass(type=double,outSize=s3d) '
```

## See Also

[TestRunner](#) | [fromFile](#) | [matlab.unittest.selectors](#)

# matlab.unittest.TestSuite.fromMethod

---

**Purpose** Create TestSuite array from single test method

**Syntax**

```
suite =
matlab.unittest.TestSuite.fromMethod(testClass, testMethod)
suite =
matlab.unittest.TestSuite.fromMethod(testClass, testMethod, s)
suite =
matlab.unittest.TestSuite.fromMethod(___, Name, Value)
```

**Description**

```
suite =
matlab.unittest.TestSuite.fromMethod(testClass, testMethod)
```

creates a TestSuite array from the test class described by `testClass` and the test method described by `testMethod` and returns it in `suite`.

```
suite =
matlab.unittest.TestSuite.fromMethod(testClass, testMethod, s)
```

creates a TestSuite array from all of the Test methods contained in `testMethod` that satisfy the conditions specified by the selector, `s`.

```
suite =
matlab.unittest.TestSuite.fromMethod(___, Name, Value)
```

creates a TestSuite array with additional options specified by one or more `Name, Value` pair arguments. You can use this syntax with any of the input arguments of the previous syntaxes.

**Tips**

- `testClass` must be on the MATLAB path when using this method to create `suite`, as well as when `suite` is run.

**Input Arguments**

**testClass**

Class describing the test methods, specified as a `meta.class` instance which must derive from `matlab.unittest.TestCase`.

**testMethod**

Test method, specified by either the `meta.method` instance or the name as a string. The method must be defined with a `Test` method attribute.

**s**

Selector, specified as an instance of a class from the `matlab.unittest.selector` package.

## **Name-Value Pair Arguments**

### **'Name'**

String indicating the name of the suite element. To include a test element in the suite, the `Name` property of the test element must match the specified name. Use the wildcard character, `*`, to match any number of characters. Use the question mark character, `?`, to match to exactly one character.

### **'ParameterProperty'**

String indicating the name of a property that defines a parameter used by the test suite element. Use the wildcard character, `*`, to match any number of characters. Use the question mark character, `?`, to match to exactly one character.

### **'ParameterName'**

String indicating the name of a parameter used by the test suite element. Use the wildcard character, `*`, to match any number of characters. Use the question mark character, `?`, to match to exactly one character.

### **'BaseFolder'**

String indicating the name of the folder that contains the file defining the test class or function. For a test element to be included in the suite, the test element must be contained in the specified base folder. Use the wildcard character, `*`, to match any number of characters. Use the question mark character, `?`, to match to exactly one character. For test classes defined in

# matlab.unittest.TestSuite.fromMethod

---

packages, the base folder is the parent of the top-level package folder.

## Output Arguments

**suite**

Set of tests, specified as a `matlab.unittest.Test` array.

## Attributes

Static

true

To learn about attributes of methods, see [Method Attributes](#) in the [MATLAB Object-Oriented Programming](#) documentation.

## Examples

### Run a Single Test Method

Add the `matlab.unittest.TestSuite` class to the current import list.

```
import matlab.unittest.TestSuite;

cls = ?mypackage.MyTestClass;

% Create the suite using the method name
suite = TestSuite.fromMethod(cls, 'testMethod');
result = run(suite)

% Create the suite using the meta.method instance
metaMethod = findobj(cls.MethodList, 'Name', 'testMethod');
suite = TestSuite.fromMethod(cls, metaMethod);
result = run(suite)
```

### Create Suite of Test Elements Using Selector

In your working folder, create the following `testZeros.m` test file. This class contains four test methods.

```
classdef testZeros < matlab.unittest.TestCase
 properties (TestParameter)
```



```
type = {'single','double','uint16'};
outSize = struct('s2d',[3 3], 's3d',[2 5 4]);
end

methods (Test)
function testClass(testCase, type, outSize)
 testCase.verifyClass(zeros(outSize,type), type);
end

function testSize(testCase, outSize)
 testCase.verifySize(zeros(outSize), outSize);
end

function testDefaultClass(testCase)
 testCase.verifyClass(zeros, 'double');
end
function testDefaultSize(testCase)
 testCase.verifySize(zeros, [1 1]);
end

function testDefaultValue(testCase)
 testCase.verifyEqual(zeros,0);
end
end
end
```

The test class contains two parameterized test methods, `testClass` and `testSize`.

At the command prompt, create a test suite from all parameterized tests from the `testClass` method that use the parameter name 'double'.

```
import matlab.unittest.TestSuite;
import matlab.unittest.selectors.HasParameter;

suite = TestSuite.fromMethod(?testZeros,'testClass', ...
 HasParameter('Name','single'));
```

# matlab.unittest.TestSuite.fromMethod

---

```
{suite.Name}'

ans =

 'testZeros/testClass(type=single,outSize=s2d) '
 'testZeros/testClass(type=single,outSize=s3d) '
```

## Create Suite of Test Elements Using Name-Value Arguments

Create the `testZeros.m` class from the previous example.

At the command prompt, create a test suite from all parameterized tests from the `testClass` method that use the parameter name `'double'`.

```
import matlab.unittest.TestSuite;

suite = TestSuite.fromMethod(?testZeros,'testClass', ...
 'ParameterName','single');
{suite.Name}'

ans =

 'testZeros/testClass(type=single,outSize=s2d) '
 'testZeros/testClass(type=single,outSize=s3d) '
```

## See Also

[TestRunner](#) | [fromClass](#) | [fromPackage](#) |  
[matlab.unittest.selectors](#)

# matlab.unittest.TestSuite.fromName

---

**Purpose** Create Test object from name of test element

**Syntax** `testObj = matlab.unittest.TestSuite.fromName(name)`

**Description** `testObj = matlab.unittest.TestSuite.fromName(name)` creates a scalar Test object, `testObj`, from the name of the test element, `name`.

**Input Arguments**

**name**

Name of the `matlab.unittest.Test` element, specified as a string. `name` contains the name of the `TestCase` class or function and the test method or local function, as well as information about test parameterization. The name argument corresponds to the `Name` property of the Test object.

The test class or function described by `name` must be on the MATLAB path when you are creating and running the `TestSuite`.

**Attributes**

Static true

To learn about attributes of methods, see [Method Attributes](#) in the MATLAB Object-Oriented Programming documentation.

**Examples**

**Create and Run Test from Test Suite Element**

Create a function to test, `add5`, in a file on your MATLAB path.

```
function res = add5(x)
%ADD5 Increment input by 5.
if ~isa(x,'numeric')
 error('add5:InputMustBeNumeric','Input must be numeric.');
```

end  
res = x + 5;  
end

# matlab.unittest.TestSuite.fromName

---

Create a file, `Add5Test.m`, on your MATLAB path that contains the following `TestCase` class.

```
classdef Add5Test < matlab.unittest.TestCase
 properties (TestParameter)
 Type = {'double','single','int8','int32'};
 end

 methods (Test)
 function testNonNumericInput(testCase)
 testCase.verifyError(@()add5('0'),'add5:InputMustBeNumeric');
 end
 function testResultType(testCase, Type)
 actOutput = add5(cast(1,Type));
 testCase.verifyClass(actOutput, Type);
 end
 end
end
```

At the command prompt, create a test object for the `testNonNumericInput` method in the `Add5Test` class.

```
import matlab.unittest.TestSuite;
testObj = TestSuite.fromName('Add5Test/testNonNumericInput');
```

Run the test

```
result = run(testObj);
```

```
Running Add5Test
.
Done Add5Test
```

---

Create a parameterized test for the `testResultType` method in the `Add5Test` class, and run the test.

# matlab.unittest.TestSuite.fromName

---

```
testObj = TestSuite.fromName('Add5Test/testResultType(Type=single)');
result = run(testObj);
```

```
Running Add5Test
.
Done Add5Test
```

---

**See Also** TestRunner

# matlab.unittest.TestSuite.fromPackage

---

<b>Purpose</b>	Create TestSuite array from all tests in package
<b>Syntax</b>	<pre>suite = matlab.unittest.TestSuite.fromPackage(package) suite = matlab.unittest.TestSuite.fromPackage(package,s) suite = matlab.unittest.TestSuite.fromPackage( ___,Name,Value)</pre>
<b>Description</b>	<p>suite = matlab.unittest.TestSuite.fromPackage(package) creates a TestSuite array from all of the Test methods of all concrete TestCase classes contained in package and returns that array in suite. The method is not recursive, returning only those tests directly in the package specified.</p> <p>suite = matlab.unittest.TestSuite.fromPackage(package,s) creates a TestSuite array from all of the Test methods contained in package that satisfy the conditions specified by the selector, s.</p> <p>suite = matlab.unittest.TestSuite.fromPackage( ___,Name,Value) creates a TestSuite array with additional options specified by one or more Name, Value pair arguments. You can use this syntax with any of the input arguments of the previous syntaxes.</p>
<b>Tips</b>	<ul style="list-style-type: none"><li>• The root folder(s) where package is defined must be on the MATLAB path when creating suite using this method as well as when suite is run.</li></ul>
<b>Input Arguments</b>	<p><b>package</b> The name of the desired package to find tests, specified as a string.</p> <p><b>s</b> Selector, specified as an instance of a class from the matlab.unittest.selector package.</p>

## Name-Value Pair Arguments

### 'IncludingSubpackages'

Indicator for whether to include subpackages in the `TestSuite` array. This property is `false` by default. You can specify it as `true` during construction.

### 'Name'

String indicating the name of the suite element. To include a test element in the suite, the `Name` property of the test element must match the specified name. Use the wildcard character, `*`, to match any number of characters. Use the question mark character, `?`, to match to exactly one character.

### 'ParameterProperty'

String indicating the name of a property that defines a parameter used by the test suite element. Use the wildcard character, `*`, to match any number of characters. Use the question mark character, `?`, to match to exactly one character.

### 'ParameterName'

String indicating the name of a parameter used by the test suite element. Use the wildcard character, `*`, to match any number of characters. Use the question mark character, `?`, to match to exactly one character.

### 'BaseFolder'

String indicating the name of the folder that contains the file defining the test class or function. For a test element to be included in the suite, the test element must be contained in the specified base folder. Use the wildcard character, `*`, to match any number of characters. Use the question mark character, `?`, to match to exactly one character. For test classes defined in packages, the base folder is the parent of the top-level package folder.

# matlab.unittest.TestSuite.fromPackage

---

## Output Arguments

**suite**

Set of tests, specified as a matlab.unittest.Test array.

## Attributes

Static

true

To learn about attributes of methods, see Method Attributes in the MATLAB Object-Oriented Programming documentation.

## Examples

### Run All Tests in a Package

Add the matlab.unittest.TestSuite class to the current import list.

```
import matlab.unittest.TestSuite;

suite = TestSuite.fromPackage('mypackage.subpackage');
result = run(suite)
```

Run tests in mypackage including all subpackages.

```
suite = TestSuite.fromPackage('mypackage', 'IncludingSubpackages', true);
result = run(suite)
```

### Create Suite of Test Elements Using Selector

In your working folder, create a new package by creating a new folder, +myPackage. In that folder, create the following testZeros.m test file. This class contains four test methods.

```
classdef testZeros < matlab.unittest.TestCase
 properties (TestParameter)
 type = {'single', 'double', 'uint16'};
 outSize = struct('s2d', [3 3], 's3d', [2 5 4]);
 end

 methods (Test)
 function testClass(testCase, type, outSize)
 testCase.verifyClass(zeros(outSize, type), type);
 end
 end
end
```



# matlab.unittest.TestSuite.fromPackage

---

```
end

function testSize(testCase, outSize)
 testCase.verifySize(zeros(outSize), outSize);
end

function testDefaultClass(testCase)
 testCase.verifyClass(zeros, 'double');
end

function testDefaultSize(testCase)
 testCase.verifySize(zeros, [1 1]);
end

function testDefaultValue(testCase)
 testCase.verifyEqual(zeros,0);
end
end
end
```

The test class contains two parameterized test methods, `testClass` and `testSize`.

At the command prompt, create a test suite from all parameterized tests that use the parameter property 'outSize'.

```
import matlab.unittest.TestSuite;
import matlab.unittest.selectors.HasParameter;

suite = TestSuite.fromPackage('myPackage', ...
 HasParameter('Property','outSize'));
{suite.Name}'

ans =

 'myPackage.testZeros/testClass(type=single,outSize=s2d)'
 'myPackage.testZeros/testClass(type=single,outSize=s3d)'
 'myPackage.testZeros/testClass(type=double,outSize=s2d)'
```

# matlab.unittest.TestSuite.fromPackage

---

```
'myPackage.testZeros/testClass(type=double,outSize=s3d)'
'myPackage.testZeros/testClass(type=uint16,outSize=s2d)'
'myPackage.testZeros/testClass(type=uint16,outSize=s3d)'
'myPackage.testZeros/testSize(outSize=s2d)'
'myPackage.testZeros/testSize(outSize=s3d)'
```

## Create Suite of Test Elements Using Name-Value Arguments

Create the `+myPackage` folder and `testZeros.m` class from the previous example.

At the command prompt, create a test suite from all parameterized tests that use the parameter property `'outSize'`.

```
import matlab.unittest.TestSuite;

suite = TestSuite.fromPackage('myPackage', ...
 'ParameterProperty', 'outSize');
{suite.Name}'

ans =

'myPackage.testZeros/testClass(type=single,outSize=s2d)'
'myPackage.testZeros/testClass(type=single,outSize=s3d)'
'myPackage.testZeros/testClass(type=double,outSize=s2d)'
'myPackage.testZeros/testClass(type=double,outSize=s3d)'
'myPackage.testZeros/testClass(type=uint16,outSize=s2d)'
'myPackage.testZeros/testClass(type=uint16,outSize=s3d)'
'myPackage.testZeros/testSize(outSize=s2d)'
'myPackage.testZeros/testSize(outSize=s3d)'
```

## See Also

[TestRunner](#) | [fromMethod](#) | [fromClass](#) | [matlab.unittest.selectors](#)

<b>Purpose</b>	Run <code>TestSuite</code> array using <code>TestRunner</code> object configured for text output
<b>Syntax</b>	<code>result = run(suite)</code>
<b>Description</b>	<code>result = run(suite)</code> runs the <code>TestSuite</code> object defined by <code>suite</code> using a <code>TestRunner</code> object configured for text output.
<b>Tips</b>	<ul style="list-style-type: none"><li>This is a convenience method which is equivalent to using a <code>TestRunner</code> object created from the <code>TestRunner.withTextOutput</code> method to run <code>suite</code>.</li></ul>
<b>Input Arguments</b>	<p><b>suite</b></p> <p>Set of tests, specified as a <code>matlab.unittest.TestSuite</code> array.</p>
<b>Output Arguments</b>	<p><b>result</b></p> <p>A <code>matlab.unittest.TestResult</code> object containing the result of the test run. <code>result</code> is the same size as <code>suite</code> and each element is the result of the corresponding element in <code>suite</code>.</p>
<b>Examples</b>	<p><b>Compare <code>TestSuite.run</code> with <code>TestRunner.run</code></b></p> <p>Add <code>matlab.unittest</code> classes to the current import list.</p> <pre>import matlab.unittest.TestRunner; import matlab.unittest.TestSuite;</pre> <p>Create a test suite and a test runner.</p> <pre>suite = TestSuite.fromClass(?mypackage.MyTestClass); runner = TestRunner.withTextOutput;</pre> <p>The following test results are equivalent.</p> <pre>result = runner.run(suite) result = run(suite)</pre>

# matlab.unittest.TestSuite.run

---

## See Also

[matlab.unittest.TestRunner.run](#) | [matlab.unittest.TestCase.run](#)

## Purpose

Select test suite elements that satisfy conditions

## Syntax

```
newsuite = selectIf(suite,s)
newsuite = selectIf(suite,Name,Value)
```

## Description

`newsuite = selectIf(suite,s)` selects from `suite` the test elements that satisfy the conditions specified by the selector, `s`, and returns them in the `TestSuite` array, `newsuite`.

`newsuite = selectIf(suite,Name,Value)` creates a `TestSuite` array with additional options specified by one or more `Name,Value` pair arguments.

## Input Arguments

### `suite`

Set of tests, specified as a `matlab.unittest.TestSuite` array.

### `s`

Selector, specified as an instance of a class from the `matlab.unittest.selector` package.

### Name-Value Pair Arguments

Specify optional comma-separated pairs of `Name,Value` arguments. `Name` is the argument name and `Value` is the corresponding value. `Name` must appear inside single quotes ( ' '). You can specify several name and value pair arguments in any order as `Name1,Value1,...,NameN,ValueN`.

### 'Name'

String indicating the name of the suite element. To include a test element in the suite, the `Name` property of the test element must match the specified name. Use the wildcard character, `*`, to match any number of characters. Use the question mark character, `?`, to match to exactly one character.

### 'ParameterProperty'

# matlab.unittest.TestSuite.selectIf

---

String indicating the name of a property that defines a parameter used by the test suite element. Use the wildcard character, \*, to match any number of characters. Use the question mark character, ?, to match to exactly one character.

## **'ParameterName'**

String indicating the name of a parameter used by the test suite element. Use the wildcard character, \*, to match any number of characters. Use the question mark character, ?, to match to exactly one character.

## **'BaseFolder'**

String indicating the name of the folder that contains the file defining the test class or function. For a test element to be included in the suite, the test element must be contained in the specified base folder. Use the wildcard character, \*, to match any number of characters. Use the question mark character, ?, to match to exactly one character. For test classes defined in packages, the base folder is the parent of the top-level package folder.

## **Examples**

### **Select Test Elements Using Selector**

In your working folder, create the file `ExampleTest.m` containing the following test class.

```
classdef (SharedTestFixtures={...
 matlab.unittest.fixtures.PathFixture(fullfile(...
 matlabroot, 'help', 'techdoc', 'matlab_oop', 'examples'))})...
 ExampleTest < matlab.unittest.TestCase
 methods(Test)
 function testPathAdd(testCase)
 % test code
 end
 function testOne(testCase)
 % test code
 end
 end
end
```

```
 function testTwo(testCase)
 % test code
 end
 end
end
```

At the command prompt, create a test suite from the ExampleTest class.

```
import matlab.unittest.TestSuite;
import matlab.unittest.selectors.HasSharedTestFixture;
import matlab.unittest.selectors.HasName;
import matlab.unittest.fixtures.PathFixture;
import matlab.unittest.constraints.EndsWithSubstring;
import matlab.unittest.constraints.ContainsSubstring;
```

```
suite = TestSuite.fromClass(?ExampleTest)
```

```
suite =
```

```
1x3 Test array with properties:
```

```
 Name
Parameterization
SharedTestFixtures
```

The test suite contains three test elements.

Create a filtered test suite of tests comprising tests with names that contain the case-insensitive substring 'pAtH'.

```
newSuite = selectIf(suite, HasName(ContainsSubstring('pAtH', 'IgnoringCase')))
```

```
newSuite =
```

```
Test with properties:
```

```
 Name: 'ExampleTest/testPathAdd'
Parameterization: []
```

# matlab.unittest.TestSuite.selectIf

---

```
SharedTestFixtures: [1x1 matlab.unittest.fixtures.PathFixture]
```

Only the `testPathAdd` test is part of the suite.

Alternatively, create the same suite using a name-value pair.

```
newSuite = selectIf(suite, 'Name', '*Path*');
```

However, unlike the `ContainsSubstring` constraint, the name-value pair does not have an option to ignore case.

Create a filtered suite of tests comprising tests that use a shared path fixture and do not have names ending with `'One'`.

```
newSuite = suite.selectIf(~HasName(EndsWithSubstring('One')) ...
 & HasSharedTestFixture(PathFixture(fullfile(matlabroot, 'help', ...
 'techdoc', 'matlab_oop', 'examples'))));
{newSuite.Name}
```

```
ans =
```

```
 'ExampleTest/testPathAdd' 'ExampleTest/testTwo'
```

The test suite contains two tests. All of the tests use the specified path fixture, but the test named `'testOne'` is excluded from the suite.

## Select Test Elements Using Parameterization

In your working folder, create `testZeros.m`. This class contains four test methods.

```
classdef testZeros < matlab.unittest.TestCase
 properties (TestParameter)
 type = {'single', 'double', 'uint16'};
 outSize = struct('s2d', [3 3], 's3d', [2 5 4]);
 end

 methods (Test)
 function testClass(testCase, type, outSize)
```



```
 testCase.verifyClass(zeros(outSize,type), type);
 end

 function testSize(testCase, outSize)
 testCase.verifySize(zeros(outSize), outSize);
 end

 function testDefaultClass(testCase)
 testCase.verifyClass(zeros, 'double');
 end
 function testDefaultSize(testCase)
 testCase.verifySize(zeros, [1 1]);
 end

 function testDefaultValue(testCase)
 testCase.verifyEqual(zeros,0);
 end
end
end
```

The test class contains two parameterized test methods, `testClass` and `testSize`.

At the command prompt, create a test suite from the file.

```
s = matlab.unittest.TestSuite.fromFile('testZeros.m');
{s.Name}'
```

```
ans =
```

```
'testZeros/testClass(type=single,outSize=s2d)'
'testZeros/testClass(type=single,outSize=s3d)'
'testZeros/testClass(type=double,outSize=s2d)'
'testZeros/testClass(type=double,outSize=s3d)'
'testZeros/testClass(type=uint16,outSize=s2d)'
'testZeros/testClass(type=uint16,outSize=s3d)'
'testZeros/testSize(outSize=s2d)'
'testZeros/testSize(outSize=s3d)'
```

# matlab.unittest.TestSuite.selectIf

---

```
'testZeros/testDefaultClass'
'testZeros/testDefaultSize'
'testZeros/testDefaultValue'
```

The suite contains 11 test elements. Six from the parameterized `testClass` method, two from the parameterized `testSize` method, and one from each of the `testDefaultClass`, `testDefaultSize`, and `testDefaultValue` methods.

Select all of the test elements from parameterized test methods.

```
import matlab.unittest.selectors.HasParameter;

s1 = s.selectIf(HasParameter);
{s1.Name}'

ans =

'testZeros/testClass(type=single,outSize=s2d)'
'testZeros/testClass(type=single,outSize=s3d)'
'testZeros/testClass(type=double,outSize=s2d)'
'testZeros/testClass(type=double,outSize=s3d)'
'testZeros/testClass(type=uint16,outSize=s2d)'
'testZeros/testClass(type=uint16,outSize=s3d)'
'testZeros/testSize(outSize=s2d)'
'testZeros/testSize(outSize=s3d)'
```

The suite contains the eight test elements from the two parameterized test methods.

Select all of the test elements from non-parameterized test methods.

```
s2 = s.selectIf(~HasParameter);
{s2.Name}'

ans =

'testZeros/testDefaultClass'
```

```
'testZeros/testDefaultSize'
'testZeros/testDefaultValue'
```

Select all test elements that are parameterized and have a property named 'type' with a parameter name 'double'.

```
s3 = s.selectIf('ParameterProperty','type','ParameterName','double'),
{s3.Name}'
```

```
ans =
```

```
'testZeros/testClass(type=double,outSize=s2d)'
'testZeros/testClass(type=double,outSize=s3d)'
```

The resulting suite contains two elements. The `testClass` method is the only method in `testZeros` that uses the 'type' property, and selecting only 'double' from the parameters results in two test elements — one for each value of 'outSize'.

Select all test elements that are parameterized and have a parameters defined by a property starting with 't'.

```
s4 = s.selectIf('ParameterProperty','t*');
{s4.Name}'
```

```
ans =
```

```
'testZeros/testClass(type=single,outSize=s2d)'
'testZeros/testClass(type=single,outSize=s3d)'
'testZeros/testClass(type=double,outSize=s2d)'
'testZeros/testClass(type=double,outSize=s3d)'
'testZeros/testClass(type=uint16,outSize=s2d)'
'testZeros/testClass(type=uint16,outSize=s3d)'
```

The resulting suite contains the six parameterized test elements from the `testClass` method. The `testSize` method is parameterized, but the elements from the method are not included in the suite because the method does not use a property that starts with 't'.

# matlab.unittest.TestSuite.selectIf

---

Select all test elements that are parameterized and test the `zeros` function with a 2-D array. A parameter value representing a 2-D array will have a length of 1 (e.g. `zeros(3)`) or 2 (e.g. `zeros(2,3)`).

```
import matlab.unittest.constraints.HasLength;

s5 = s.selectIf(HasParameter('Property','outSize',...
 'Value', HasLength(1)|HasLength(2)));
{s5.Name}'
```

```
ans =

 'testZeros/testClass(type=single,outSize=s2d) '
 'testZeros/testClass(type=double,outSize=s2d) '
 'testZeros/testClass(type=uint16,outSize=s2d) '
 'testZeros/testSize(outSize=s2d) '
```

Select only the test element that tests that the output is a `double` data type and the has the correct size for a 2-D array.

```
s6 = s.selectIf(HasParameter('Property','type','Name','double')...
 & HasParameter('Property','outSize','Name','s2d'))
```

```
s6 =
```

```
Test with properties:
```

```
 Name: 'testZeros/testClass(type=double,outSize=s2d) '
Parameterization: [1x2 matlab.unittest.parameters.TestParameter]
SharedTestFixtures: []
```

## See Also

[matlab.unittest.constraints](#) | [matlab.unittest.selectors](#)

**Purpose** Format text into TeX string

**Syntax**  
`TeXString = texlabel(f)`  
`TeXString = texlabel(f, 'literal')`

**Description** `TeXString = texlabel(f)` converts the MATLAB expression `f` into the TeX equivalent for use in text strings. `texlabel` converts Greek variable names (for example, `lambda`, `delta`, and so on) into a string that is displayed as Greek letters. The TeXString output is useful as an argument to annotation functions such as `title`, `xlabel`, and `text`.

If TeXString is too long to fit into a figure window, then the center of the expression is replaced with a tilde ellipsis (~~~).

`TeXString = texlabel(f, 'literal')` interprets Greek variable names literally.

**Input Arguments** **f - Input MATLAB expression**  
string

Input MATLAB expression, specified as a string.

**Example:** `'theta (degrees)'`

**Data Types**  
char

**Examples** **Insert TeX String in Figure**

Create a figure and a TeX string for use in a text graphics object.

```
figure
plot((1:10).^2)
TeXString = texlabel('lambda 12^(3/2)/pi - pi*delta^(2/3)');
```

# texlabel

---

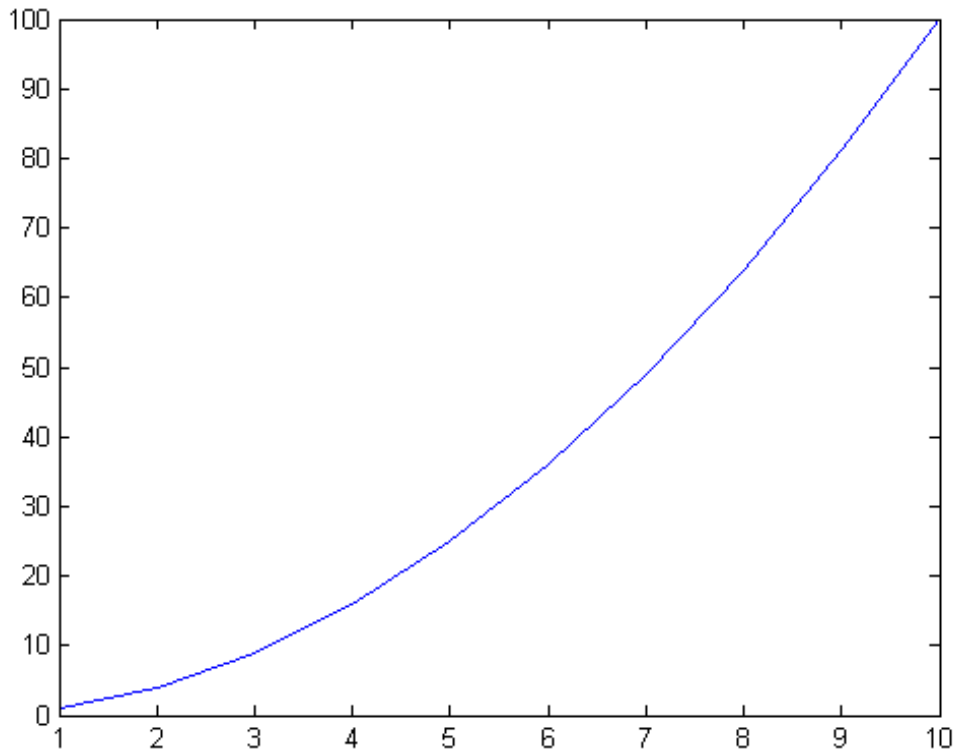

Add a text object containing the TeX string to the figure.

```
text(3,90,TeXString)
```

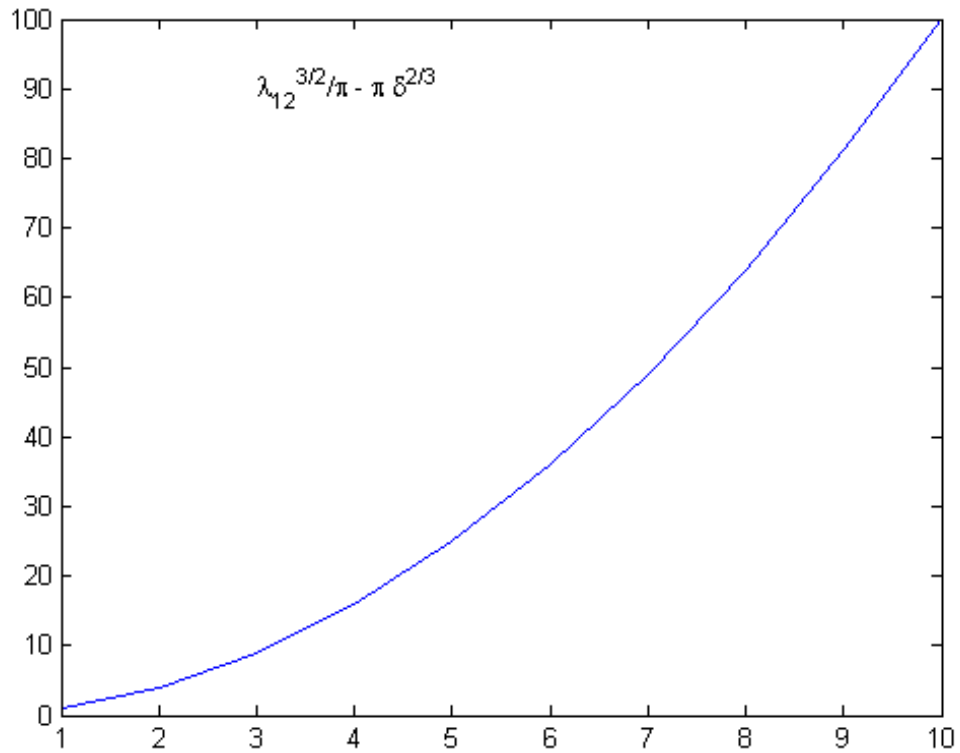

If you include the 'literal' argument, `texlabel` interprets Greek variable names literally. Add a text object containing the literal string.

```
text(4,60,texlabel('lambda12^(3/2)/pi - pi*delta^(2/3)','literal'))
```

# texlabel

---

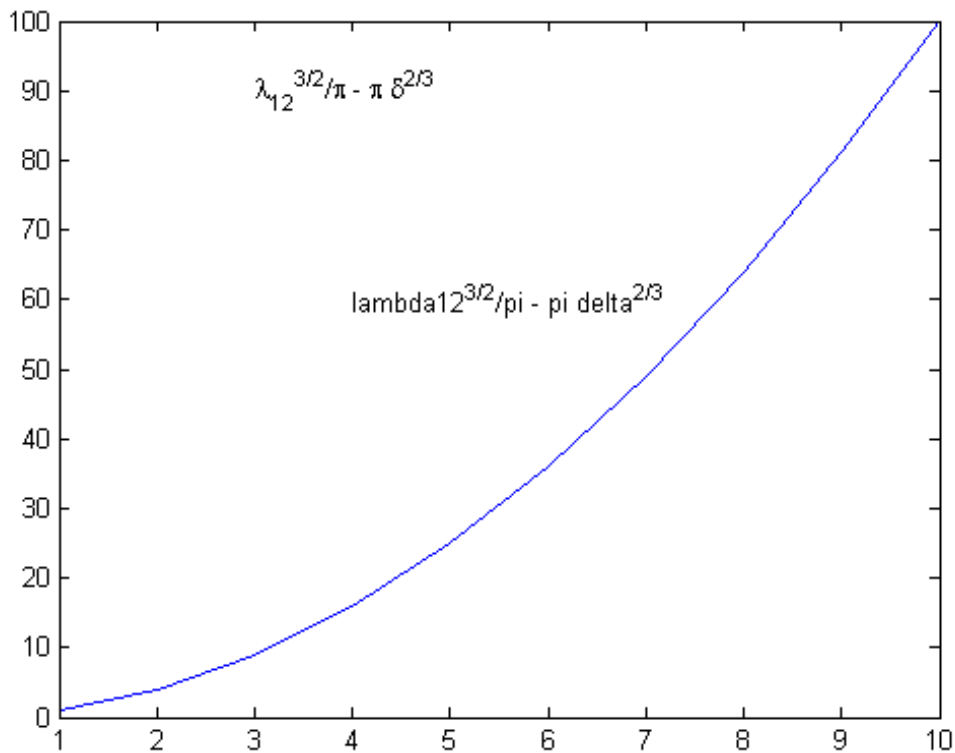

## See Also

`text` | `title` | `xlabel` | `ylabel` | `zlabel` | `String`



**Purpose**

Create text object in current axes

**Syntax**

```
text(x,y,'string')
text(x,y,z,'string')
text(x,y,z,'string','PropertyName',PropertyValue....)
text('PropertyName',PropertyValue....)
h = text(...)
```

**Properties**

For a list of properties, see [Text Properties](#).

**Description**

`text` is the low-level function for creating text graphics objects. Use `text` to place character strings at specified locations.

`text(x,y,'string')` adds the string in quotes to the location specified by the point  $(x,y)$   $x$  and  $y$  must be numbers of class `double`.

`text(x,y,z,'string')` adds the string in 3-D coordinates.  $x$ ,  $y$  and  $z$  must be numbers of class `double`.

`text(x,y,z,'string','PropertyName',PropertyValue....)` adds the string in quotes to the location defined by the coordinates and uses the values for the specified text properties. For a description of the properties, see [Text Properties](#).

`text('PropertyName',PropertyValue....)` omits the coordinates entirely and specifies all properties using property name/property value pairs.

`h = text(...)` returns a column vector of handles to text objects, one handle per object. All forms of the `text` function optionally return this output argument.

See the [String](#) property for a list of symbols, including Greek letters.

**Tips****Position Text Within the Axes**

The default text units are the units used to plot data in the graph. Specify the text location coordinates (the  $x$ ,  $y$ , and  $z$  arguments) in the data units of the current graph (see “Examples” on page 1-6977). You can use other units to position the text by setting the `text Units`

property to normalized or one of the nonrelative units (pixels, inches, centimeters, points, or characters).

Note that the Axes Units property controls the positioning of the Axes within the figure and is not related to the axes data units used for graphing.

The Extent, VerticalAlignment, and HorizontalAlignment properties control the positioning of the character string with regard to the text location point.

If the coordinates are vectors, text writes the string at all locations defined by the list of points. If the character string is an array the same length as x, y, and z, text writes the corresponding row of the string array at each point specified.

## **Multiline Text**

When specifying strings for multiple text objects, the string can be:

- A cell array of strings
- A padded string matrix

Each element of the specified string array creates a different text object.

When specifying the string for a single text object, cell arrays of strings and padded string matrices result in a text object with a multiline string, while vertical slash characters are not interpreted as separators and result in a single line string containing vertical slashes.

## **Behavior of the Text Function**

text is a low-level function that accepts property name/property value pairs as input arguments. However, the convenience form:

```
text(x,y,z,'string')
```

is equivalent to:

```
text('Position',[x,y,z],'String','string')
```

You can specify other properties only as property name/property value pairs. For a description of each property, see `Text Properties`. You can specify properties as property name/property value pairs, structure arrays, and cell arrays (see the `set` and `get` reference pages for examples of how to specify these data types).

`text` does not respect the setting of the figure or axes `NextPlot` property. This allows you to add text objects to an existing axes without setting `hold` to on.

## Examples

### Label Point on Graph

Annotate the point  $(\pi, 0)$  with the string  $\sin(\pi)$ .

```
x = 0:pi/20:2*pi;
y = sin(x);

figure % new figure window
plot(x,y);
text(pi,0,' \leftarrow sin(\pi)')
```

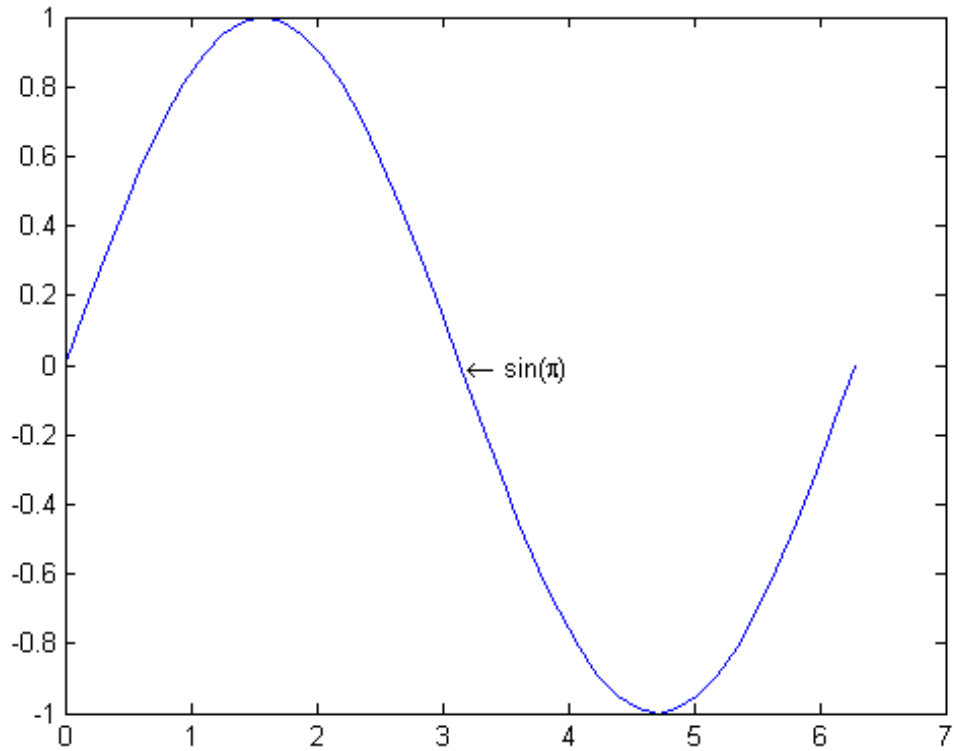

### Display Equation with Greek Symbols

Use embedded TeX sequences to display an equation in an empty axes.

```
axes
text(0.5,0.5, '\ite^{i\omega\tau} = \cos(\omega\tau) + i \sin(\omega\tau)')
```

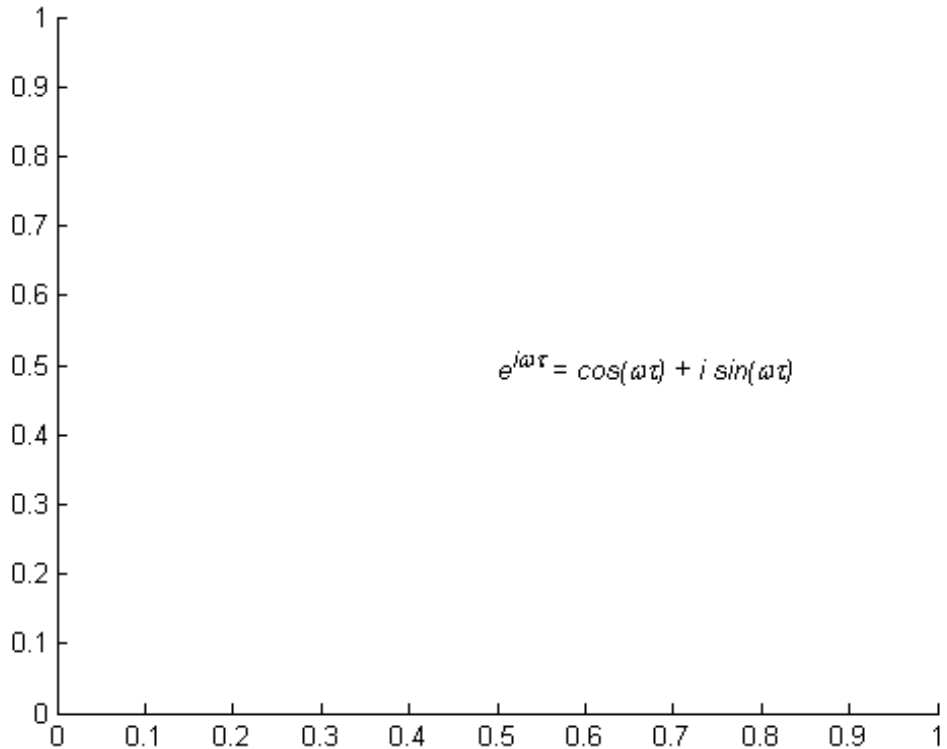

## Setting Default Properties

You can set default text properties on the axes, figure, and root object levels:

```
set(0, 'DefaulttextProperty', PropertyValue...)
set(gcf, 'DefaulttextProperty', PropertyValue...)
set(gca, 'DefaulttextProperty', PropertyValue...)
```

Where *Property* is the name of the text property and *PropertyValue* is the value you are specifying. Use `set` and `get` to access text properties.

# text

---

## **See Also**

annotation | gtext | int2str | num2str | strings | title | xlabel  
| ylabel | zlabel | Text Properties

## Purpose

Text properties

## Creating Text Objects

Use text to create text objects.

## Modifying Properties

You can set and query graphics object properties using the property editor or the `set` and `get` commands.

- Property Editor is an interactive tool that enables you to see and change object property values.
- The `set` and `get` commands enable you to set and query the values of properties.

To change the default values of properties, see [Setting Default Property Values](#).

See [Core Objects](#) for general information about this type of object.

## Text Property Descriptions

This section provides a description of properties. Curly braces { } enclose default values.

### Annotation

`hg.Annotation` object (read-only)

*Handle of Annotation object.* The `Annotation` property enables you to specify whether this text object is represented in a figure legend.

Querying the `Annotation` property returns the handle of an `hg.Annotation` object. The `hg.Annotation` object has a property called `LegendInformation`, which contains an `hg.LegendEntry` object.

Once you have obtained the `hg.LegendEntry` object, you can set its `IconDisplayStyle` property to control whether the text object is displayed in a figure legend:

# Text Properties

---

IconDisplayStyle Value	Purpose
on	Represent this text object in a legend (default)
off	Do not include this text object in a legend
children	Same as on because text objects do not have children

## Setting the IconDisplayStyle property

Set the IconDisplayStyle of a graphics object with handle `hobj` to off:

```
hAnnotation = get(hobj, 'Annotation');
hLegendEntry = get(hAnnotation, 'LegendInformation');
set(hLegendEntry, 'IconDisplayStyle', 'off')
```

## Using the IconDisplayStyle property

See “Control Legend Content” for more information and examples.

BackgroundColor  
ColorSpec | {none}

*Color of text extent rectangle.* Defines a color for the rectangle that encloses the text Extent plus the text Margin. For example, the following code creates a text object that labels a plot and sets the background color to light green.

```
text(3*pi/4, sin(3*pi/4), ...
 ['sin(3*pi/4) = ', num2str(sin(3*pi/4))], ...
 'HorizontalAlignment', 'center', ...
 'BackgroundColor', [.7 .9 .7]);
```



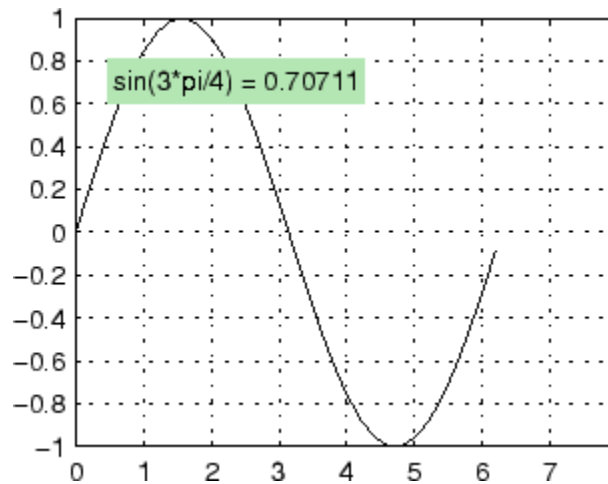

For additional features, see the following properties:

- `EdgeColor` — Color of the rectangle's edge (none by default).
- `LineStyle` — Style of the rectangle's edge line (first set `EdgeColor`)
- `LineWidth` — Width of the rectangle's edge line (first set `EdgeColor`)
- `Margin` — Increase the size of the rectangle by adding a margin to the existing text extent rectangle. This margin is added to the text extent rectangle to define the text background area that is enclosed by the `EdgeColor` rectangle. Note that the text extent does not change when you change the margin; only the rectangle displayed when you set the `EdgeColor` property and the area defined by the `BackgroundColor` change.

See also [Drawing Text in a Box](#) in the MATLAB Graphics documentation for an example using background color with contour labels.

# Text Properties

---

## BeingDeleted

on | {off} (read-only)

*This object is being deleted.* Mechanism to determine if objects are in the process of being deleted. MATLAB sets the `BeingDeleted` property to `on` when the object's delete function callback is called (see the `DeleteFcn` property). It remains set to `on` while the delete function executes, after which the object no longer exists.

For example, an object's delete function calls other functions that act on a number of different objects. If a function does not need to perform an action on an about-be-deleted object, it can check the object's `BeingDeleted` property before acting.

## BusyAction

cancel | {queue}

### *Callback queuing*

Determines how MATLAB handles the execution of interrupting callbacks.

A *running* callback is the currently executing callback. The *interrupting* callback is the callback that tries to interrupt the *running* callback. The `BusyAction` property of the *interrupting* callback determines how MATLAB handles its execution. When the `BusyAction` property is set to:

- 'queue' — Puts the *interrupting* callback in a queue to be processed after the *running* callback finishes execution.
- 'cancel' — Discards the *interrupting* callback as MATLAB finishes execution.

For information about how the `Interruptible` property of the callback controls whether other callbacks can interrupt the *running* callback, see the `Interruptible` property description.

## ButtonDownFcn

function handle | cell array containing function handle and additional arguments | string (not recommended)

*Button press callback function.* Executes whenever you press a mouse button while the pointer is over the text object.

See the figure's `SelectionType` property to determine if modifier keys were also pressed.

Set this property to a function handle that references the callback. The function must define at least two input arguments (handle of object associated with the button down event and an event structure, which is empty for this property).

The following example shows how to access the callback object's handle as well as the handle of the figure that contains the object from the callback function.

```
function button_down(src, evnt)
% src - the object that is the source of the event
% evnt - empty for this property
 sel_typ = get(gcf, 'SelectionType')
 switch sel_typ
 case 'normal'
 disp('User clicked left-mouse button')
 set(src, 'Selected', 'on')
 case 'extend'
 disp('User did a shift-click')
 set(src, 'Selected', 'on')
 case 'alt'
 disp('User did a control-click')
 set(src, 'Selected', 'on')
 set(src, 'SelectionHighlight', 'off')
 end
end
```

# Text Properties

---

Suppose `h` is the handle of a text object and the `button_down` function is on your MATLAB path. The following statement assigns the `button_down` function to the `ButtonDownFcn` property:

```
set(h, 'ButtonDownFcn', @button_down)
```

For information on the syntax of callback functions, see [Function Handle Callbacks](#).

## Children

matrix (read-only)

The empty matrix; text objects have no children.

## Clipping

on | {off}

*Clipping mode.* When `Clipping` is on, MATLAB does not display any portion of the text that is outside the axes.

## Color

ColorSpec

*Text color.* A three-element RGB vector or one of the predefined names, specifying the text color. The default value is `[0 0 0]` (black). See the [ColorSpec](#) reference page for more information on specifying color.

## CreateFcn

function handle | cell array containing function handle and additional arguments | string (not recommended)

*Callback function executed during object creation.* Executes when MATLAB creates a text object. You must define this property as a default value for `text` or in a call to the `text` function that creates a new text object. For example, the statement:

```
set(0, 'DefaultTextCreateFcn', @text_create)
```

defines a default value on the root level that sets the figure `Pointer` property to crosshairs whenever you create a text object. The callback function must be on your MATLAB path when you execute the above statement.

```
function text_create(src,evnt)
% src - the object that is the source of the event
% evnt - empty for this property
 set(gcf,'Pointer','crosshair')
end
```

MATLAB executes this function after setting all text properties. Setting this property on an existing text object has no effect. The function must define at least two input arguments (handle of object created and an event structure, which is empty for this property).

The handle of the object whose `CreateFcn` is being executed is passed by MATLAB as the first argument to the callback function and is also accessible through the root `CallbackObject` property, which you can query using `gcbo`.

For information on the syntax of callback functions, see [Function Handle Callbacks](#).

## DeleteFcn

```
function handle | cell array containing function handle and
additional arguments | string (not recommended)
```

*Delete text callback function.* Executes when you delete the text object (for example, when you issue a `delete` command or clear the axes `cla` or figure `clf`).

For example, the following function displays object property data before the object is deleted.

```
function delete_fcn(src,evnt)
% src - the object that is the source of the event
```

# Text Properties

---

```
% evnt - empty for this property
 obj_tp = get(src,'Type');
 disp([obj_tp, ' object deleted'])
 disp('Its user data is:')
 disp(get(src,'UserData'))
end
```

MATLAB executes the function before deleting the object's properties so these values are available to the callback function. The function must define at least two input arguments (handle of object being deleted and an event structure, which is empty for this property).

The handle of the object whose `DeleteFcn` is being executed is passed by MATLAB as the first argument to the callback function and is also accessible through the root `CallbackObject` property, which you can query using `gcbo`.

For information on the syntax of callback functions, see [Function Handle Callbacks](#).

`DisplayName`  
string

*String used by legend.* The `legend` function uses the `DisplayName` property to label the text object in the legend. The default is an empty string.

- If you specify string arguments with the `legend` function, MATLAB set `DisplayName` to the corresponding string and uses that string for the legend.
- If `DisplayName` is empty, `legend` creates a string of the form, `['data' n]`, where `n` is the number assigned to the object based on its location in the list of legend entries. However, `legend` does not set `DisplayName` to this string.
- If you edit the string directly in an existing legend, MATLAB set `DisplayName` to the edited string.

- If you specify a string for the `DisplayName` property and create the legend using the figure toolbar, then MATLAB uses the string defined by `DisplayName`.
- To add a legend programmatically that uses the `DisplayName` string, call `legend` with the `toggle` or `show` option.

See “Control Legend Content” for more information and examples.

## EdgeColor

ColorSpec | {none}

*Color of edge drawn around text extent rectangle plus margin.*  
Specifies the color of a box drawn around the text `Extent` plus the text `Margin`. For example, the following code draws a red rectangle around text that labels a plot.

```
text(3*pi/4, sin(3*pi/4), ...
'\leftarrow sin(t) = .707', ...
'EdgeColor', 'red');
```

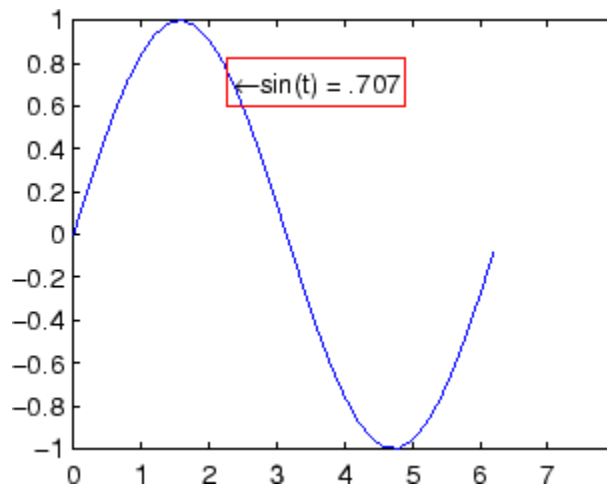

For additional features, see the following properties:

# Text Properties

---

- `BackgroundColor` — Color of the rectangle's interior (none by default)
- `LineStyle` — Style of the rectangle's edge line (first set `EdgeColor`)
- `LineWidth` — Width of the rectangle's edge line (first set `EdgeColor`)
- `Margin` — Increases the size of the rectangle by adding a margin to the area defined by the text extent rectangle. This margin is added to the text extent rectangle to define the text background area that is enclosed by the `EdgeColor` rectangle. Note that the text extent does not change when you change the margin; only the rectangle displayed when you set the `EdgeColor` property and the area defined by the `BackgroundColor` change.

## Editing

on | {off}

*Enable or disable editing mode.* When this property is off (the default), you cannot edit the text string interactively (i.e., you must change the `String` property to change the text). When you set this property to on, MATLAB enables editing and places an insert cursor wherever the mouse is within the text. To apply the new text string, do any one of the following:

- Press the **Esc** key.
- Click anywhere away from the text string.
- Reset the `Editing` property to off.

MATLAB updates the `String` property to contain the new text and resets the `Editing` property to off. You must reset the `Editing` property to on to resume editing.

## EraseMode

{normal} | none | xor | background



*Erase mode.* Controls the technique MATLAB uses to draw and erase text objects. Alternative erase modes are useful for creating animated sequences where controlling the way individual objects are redrawn is necessary to improve performance and obtain the desired effect.

- **normal** — Redraw the affected region of the display, performing the three-dimensional analysis necessary to ensure that all objects are rendered correctly. This mode produces the most accurate picture, but is the slowest. The other modes are faster, but do not perform a complete redraw and are therefore less accurate.
- **none** — Do not erase the text when it is moved or destroyed. While the object is still visible on the screen after erasing with `EraseMode none`, you cannot print it because MATLAB stores no information about its former location.
- **xor** — Draw and erase the text by performing an exclusive OR (XOR) with each pixel index of the screen beneath it. When the text is erased, it does not damage the objects beneath it. However, when text is drawn in `xor` mode, its color depends on the color of the screen beneath it. It is correctly colored only when it is over axes background `Color`, or the figure background `Color` if the axes `Color` is `none`.
- **background** — Erase the text by drawing it in the axes background `Color`, or the figure background `Color` if the axes `Color` is `none`. This damages objects that are behind the erased text, but text is always properly colored.

## Printing with Nonnormal Erase Modes

MATLAB always prints figures as if the `EraseMode` of all objects is `normal`. This means graphics objects created with `EraseMode` set to `none`, `xor`, or `background` can look different on screen than on paper. On screen, MATLAB mathematically combines layers of colors (for example, performing an XOR on a pixel color with that of the pixel behind it) and ignore three-dimensional sorting

# Text Properties

---

to obtain greater rendering speed. However, these techniques are not applied to the printed output.

You can use the `getframe` command or other screen capture applications to create an image of a figure containing nonnormal mode objects.

## Extent

position rectangle (read-only)

*Position and size of text.* A four-element vector that defines the size and position of the text string:

```
[left,bottom,width,height]
```

If the `Units` property is `data` (the default), `left` and `bottom` are the  $x$ - and  $y$ -coordinates of the lower left corner of the text `Extent`.

For all other values of `Units`, `left` and `bottom` are the distance from the lower left corner of the axes `Position` rectangle to the lower left corner of the text `Extent`. `width` and `height` are the dimensions of the `Extent` rectangle. All measurements are in units specified by the `Units` property.

## FontAngle

```
{normal} | italic | oblique
```

*Character slant.* MATLAB uses this property to select a font from those available on your particular system. Generally, setting this property to `italic` or `oblique` selects a slanted font.

## FontName

```
name (such as Courier) | FixedWidth
```

*Font family.* Specifies the name of the font to use for the text object. To display and print properly, this must be a font that your system supports. The default font is `Helvetica`.

## Specifying a Fixed-Width Font

If you want text to use a fixed-width font that looks good in any locale, you should set `FontName` to the string `FixedWidth`:

```
set(text_handle, 'FontName', 'FixedWidth')
```

This eliminates the need to hard-code the name of a fixed-width font, which might not display text properly on systems that do not use ASCII character encoding (such as in Japan where multibyte character sets are used). A properly written MATLAB application that needs to use a fixed-width font should set `FontName` to `FixedWidth` (note that this string is case sensitive) and rely on `FixedWidthFontName` to be set correctly in the end user's environment.

End users can adapt a MATLAB application to different locales or personal environments by setting the root `FixedWidthFontName` property to the appropriate value for that locale from `startup.m`.

Note that setting the root `FixedWidthFontName` property causes an immediate update of the display to use the new font.

Bitmapped fonts (e.g., Courier) cannot be rotated on the display. Therefore, when you specify a bitmapped font with the `FontName` property, this text might not be rotated correctly, for example, when used as the *y*-axis label. To avoid problems with bitmapped fonts, use TrueType fonts. For example, you might have a TrueType font named Courier New that you can use instead of Courier. See your system documentation for information on which fonts are installed on your system.

`FontSize`  
size in `FontUnits`

# Text Properties

---

*Font size.* Specifies the font size to use for text in units determined by the `FontUnits` property. The default is 10 points. 1 point =  $1/72$  inch.

## FontWeight

`{normal}` | `bold` | `light` | `demi`

*Weight of text characters.* MATLAB uses this property to select a font from those available on your particular system. Generally, setting this property to `bold` or `demi` causes MATLAB to use a bold font.

## FontUnits

`{points}` | `normalized` | `inches` | `centimeters` | `pixels`

*Font size units.* MATLAB uses this property to determine the units used by the `FontSize` property.

- `normalized` — Interpret `FontSize` as a fraction of the height of the parent axes. When you resize the axes, MATLAB modifies the screen `FontSize` accordingly.
- `pixels`, `inches`, `centimeters`, and `points` — Absolute units. 1 point =  $1/72$  inch.

Note that if you are setting both the `FontSize` and the `FontUnits` in one function call, you must set the `FontUnits` property first so that MATLAB can correctly interpret the specified `FontSize`.

## HandleVisibility

`{on}` | `callback` | `off`

*Control access to object's handle.* Determines when an object's handle is visible in its parent's list of children. `HandleVisibility` is useful for preventing command-line users from accidentally drawing into or deleting a figure that contains only user interface devices (such as a dialog box).

- `on` — Handles are always visible.

- `callback` — Handles are visible from within callback routines or functions invoked by callback routines, but not from within functions invoked from the command line. This provides a means to protect GUIs from command-line users, while allowing callback routines to have access to object handles.
- `off` — Handles are invisible at all times. Use this option when a callback invokes a function that could damage the GUI (such as evaluating a user-typed string). This option temporarily hides its own handles during the execution of that function.

When a handle is not visible in its parent's list of children, it cannot be returned by functions that obtain handles by searching the object hierarchy or querying handle properties. This includes `get`, `findobj`, `gca`, `gcf`, `gco`, `newplot`, `cla`, `clf`, and `close`.

When a handle's visibility is restricted using `callback` or `off`,

- The object's handle does not appear in its parent's `Children` property.
- Figures do not appear in the root's `CurrentFigure` property.
- Objects do not appear in the root's `CallbackObject` property or in the figure's `CurrentObject` property.
- Axes do not appear in their parent's `CurrentAxes` property.

You can set the root `ShowHiddenHandles` property to `on` to make all handles visible regardless of their `HandleVisibility` settings (this does not affect the values of the `HandleVisibility` properties).

Handles that are hidden are still valid. If you know an object's handle, you can set and get its properties, and pass it to any function that operates on handles.

```
HitTest
{on} | off
```

# Text Properties

---

*Selectable by mouse click.* Determines if the text can become the current object (as returned by the `gco` command and the figure `CurrentObject` property) as a result of a mouse click on the text. If `HitTest` is `off`, clicking the text selects the object below it (which is usually the axes containing it).

For example, suppose you define the button down function of an image (see the `ButtonDownFcn` property) to display text at the location you click with the mouse.

First define the callback routine.

```
function bd_function
pt = get(gca,'CurrentPoint');
text(pt(1,1),pt(1,2),pt(1,3),...
 '\fontsize{20}\oplus The spot to label',...
 'HitTest','off')
```

Now display an image, setting its `ButtonDownFcn` property to the callback routine.

```
load earth
image(X,'ButtonDownFcn','bd_function'); colormap(map)
```

When you click the image, MATLAB displays the text string at that location. With `HitTest` set to `off`, existing text cannot intercept any subsequent button down events that occur over the text. This enables the image's button down function to execute.

`HorizontalAlignment`  
{left} | center | right

*Horizontal alignment of text.* Specifies the horizontal justification of the text string. It determines where MATLAB places the string with regard to the point specified by the `Position` property. The following picture illustrates the alignment options.

HorizontalAlignment viewed with the VerticalAlignment set to middle (the default).



See the Extent property for related information.

See “Text Alignment” for more information and examples.

Interpreter

latex | {tex} | none

*Interpret TeXinstructions.* Controls whether MATLAB interprets certain characters in the String property as TeX instructions (default) or displays all characters literally.

- latex — Supports a basic subset of the LaTeX markup language.
- tex — Supports a subset of plain TeX markup language. See the String property for a list of supported TeX instructions.
- none — Displays literal characters.

## LaTeX Interpreter

To enable the LaTeX interpreter for text objects, set the Interpreter property to latex. For example, the following statement displays an equation in a figure at the point [.5 .5], and enlarges the font to 16 points.

```
text('Interpreter','latex',...
 'String','$$\int_0^x \! \! \int_y dF(u,v)$$',...
 'Position',[.5 .5],...
 'FontSize',16)
```

# Text Properties

---

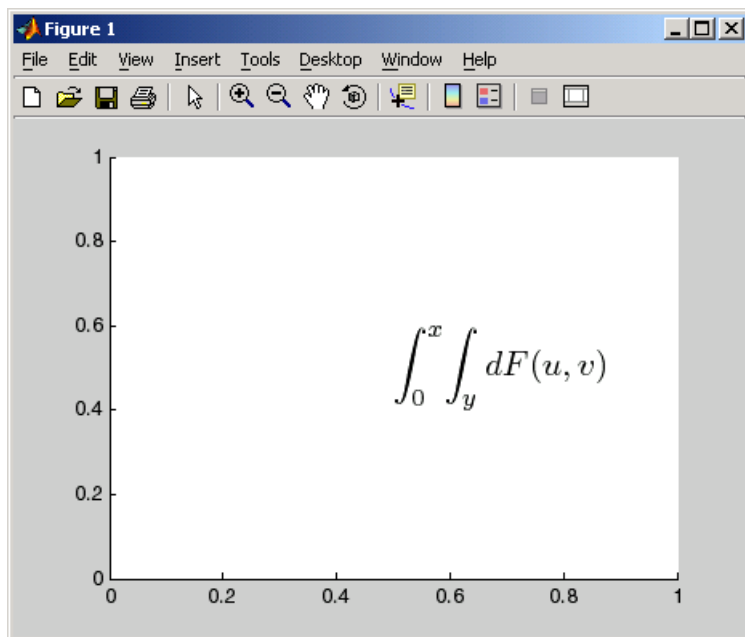

---

**Note** The maximum size of the string that you can use with the LaTeX interpreter is 1200 characters. For multiline strings, reduce this amount by about 10 characters per line.

---

## Information About Using TeX

The following references may be useful to people who are not familiar with TeX.

- Donald E. Knuth, *The T<sub>E</sub>Xbook*, Addison Wesley, 1986.
- The TeX Users Group home page: <http://www.tug.org>

Interruptible  
off | {on}



## *Callback routine interruption*

Controls whether MATLAB can interrupt an object's callback function when subsequent callbacks attempt to interrupt it.

For Graphics objects, the `Interruptible` property affects only the callbacks for the `ButtonDownFcn` property. A *running* callback is the currently executing callback. The *interrupting* callback is the callback that tries to interrupt the *running* callback. MATLAB handles both the callbacks based on the `Interruptible` property of the object of the *running* callback.

When the `Interruptible` property is set to:

- 'off', MATLAB finishes execution of the *running* callback without any interruptions
- 'on', these conditions apply:
  - If there is a `drawnow`, `figure`, `getframe`, `waitfor`, or `pause` command in the *running* callback, then MATLAB executes the *interrupting* callbacks which are already in the queue and returns to finish execution of the current callback.
  - If one of the above functions is not in the *running* callback, then MATLAB finishes execution of the current callback without any interruption.

`BusyAction` property of the object of interrupting callback determines whether the callback should be ignored or should be put in the queue.

Setting `Interruptible` property to on (default), allows a callback from other graphics objects to interrupt callback functions originating from this object.

# Text Properties

---

---

**Note** MATLAB does not save the state of properties or the display when an interruption occurs. For example, the handle returned by the `gca` or `gcf` command may be changed as another callback is executed.

---

After the function that interrupts a callback completes, the callback resumes execution where it halted when interrupted. For more information, see “Control Callback Execution and Interruption”.

## LineStyle

{-} | -- | : | -. | none

*Edge line type.* Specifies the line style used to draw the edges of the text Extent.

## Line Style Specifiers Table

Specifier	Line Style
'-'	Solid line (default)
'--'	Dashed line
':'	Dotted line
'-.'	Dash-dot line
'none'	No line

For example, the following code draws a red rectangle with a dotted line style around text that labels a plot.

```
text(3*pi/4,sin(3*pi/4),...
 '\leftarrow sin(t) = .707',...
 'EdgeColor','red',...
 'LineWidth',2,...
 'LineStyle',':');
```

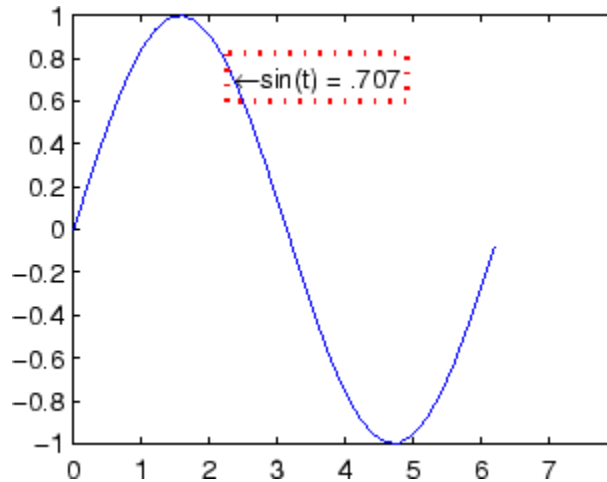

For additional features, see the following properties:

- **BackgroundColor** — Color of the rectangle's interior (none by default)
- **EdgeColor** — Color of the rectangle's edge (none by default)
- **LineWidth** — Width of the rectangle's edge line (first set `EdgeColor`)
- **Margin** — Increases the size of the rectangle by adding a margin to the existing text extent rectangle. This margin is added to the text extent rectangle to define the text background area that is enclosed by the `EdgeColor` rectangle. Note that the text extent does not change when you change the margin; only the rectangle displayed when you set the `EdgeColor` property and the area defined by the `BackgroundColor` change.

**LineWidth**  
scalar (points)

# Text Properties

---

*Width of line used to draw text extent rectangle.* When you set the text `EdgeColor` property to a color (the default is none), MATLAB displays a rectangle around the text `Extent`. Use the `LineWidth` property to specify the width of the rectangle edge. For example, the following code draws a red rectangle around text that labels a plot and specifies a line width of 3 points:

```
text(3*pi/4,sin(3*pi/4),...
'\leftarrow sin(t) = .707',...
'EdgeColor','red',...
'LineWidth',3);
```

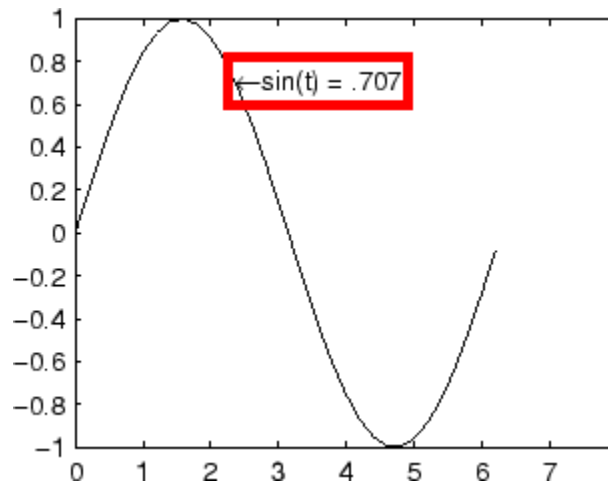

For additional features, see the following properties:

- `BackgroundColor` — Color of the rectangle's interior (none by default)
- `EdgeColor` — Color of the rectangle's edge (none by default)
- `LineStyle` — Style of the rectangle's edge line (first set `EdgeColor`)

- **Margin** — Increases the size of the rectangle by adding a margin to the existing text extent rectangle. This margin is added to the text extent rectangle to define the text background area that is enclosed by the `EdgeColor` rectangle. Note that the text extent does not change when you change the margin; only the rectangle displayed when you set the `EdgeColor` property and the area defined by the `BackgroundColor` change.

## Margin

scalar (pixels)

*Distance between the text extent and the rectangle edge.* When you specify a color for the `BackgroundColor` or `EdgeColor` text properties, MATLAB draws a rectangle around the area defined by the text `Extent` plus the value specified by the `Margin`. For example, the following code displays a light green rectangle with a 10-pixel margin.

```
text(5*pi/4, sin(5*pi/4), ...
 ['sin(5*pi/4) = ', num2str(sin(5*pi/4))], ...
 'HorizontalAlignment', 'center', ...
 'BackgroundColor', [.7 .9 .7], ...
 'Margin', 10);
```

# Text Properties

---

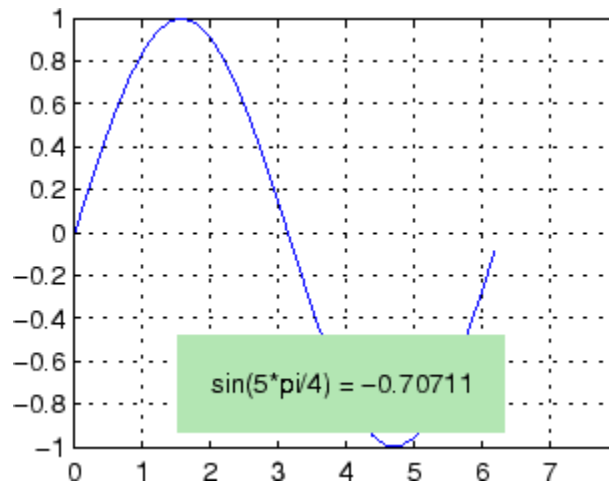

For additional features, see the following properties:

- **BackgroundColor** — Color of the rectangle's interior (none by default)
- **EdgeColor** — Color of the rectangle's edge (none by default)
- **LineStyle** — Style of the rectangle's edge line (first set **EdgeColor**)
- **LineWidth** — Width of the rectangle's edge line (first set **EdgeColor**)

## See how margin affects text extent properties

This example enables you to change the values of the **Margin** property and observe the effects on the **BackgroundColor** area and the **EdgeColor** rectangle.

[Click to view in editor](#) — This link opens the MATLAB editor with the following example.

[Click to run example](#) — Use your scroll wheel to vary the **Margin**.

## Parent

handle of axes, hggroup, or hgtransform

*Parent of text object.* Handle of the text object's parent. The parent of a text object is the axes, hggroup, or hgtransform object that contains it.

## Position

[x,y,[z]]

*Location of text.* A two- or three-element vector, [x y [z]], that specifies the location of the text in three dimensions. If you omit the z value, it defaults to 0. All measurements are in units specified by the Units property. Initial value is [0 0 0].

## Rotation

scalar (default = 0)

*Text orientation.* Determines the orientation of the text string. Specify values of rotation in degrees (positive angles cause counterclockwise rotation).

## Selected

on | {off}

*Is object selected?* When this property is on, MATLAB displays selection handles if the SelectionHighlight property is also set to on. You can, for example, define the ButtonDownFcn to set this property, allowing users to select the object with the mouse.

## SelectionHighlight

{on} | off

*Objects are highlighted when selected.* When the Selected property is on, MATLAB indicates the selected state by drawing four edge handles and four corner handles. When SelectionHighlight is off, MATLAB does not draw the handles.

# Text Properties

---

String  
string

*Text string.* Specify this property as a quoted string for single-line strings, or as a cell array of strings, or a padded string matrix for multiline strings. MATLAB displays this string at the specified location. Vertical slash characters are not interpreted as line breaks in text strings, and are drawn as part of the text string. See Mathematical Symbols, Greek Letters, and TeX Characters for an example.

---

**Note** The words `default`, `factory`, and `remove` are reserved words that will not appear in a figure when quoted as a normal string. In order to display any of these words individually, type `'\reserved_word'` instead of `'reserved_word'`.

---

When the text Interpreter property is `tex` (the default), you can use a subset of TeX commands embedded in the string to produce special characters such as Greek letters and mathematical symbols. This table lists these characters and the character sequences used to define them.

Character Sequence	Symbol	Character Sequence	Symbol	Character Sequence	Symbol
<code>\alpha</code>	$\alpha$	<code>\upsilon</code>	$\upsilon$	<code>\sim</code>	$\sim$
<code>\angle</code>	$\angle$	<code>\phi</code>	$\Phi$	<code>\leq</code>	$\leq$
<code>\ast</code>	$*$	<code>\chi</code>	$\chi$	<code>\infty</code>	$\infty$
<code>\beta</code>	$\beta$	<code>\psi</code>	$\psi$	<code>\clubsuit</code>	$\clubsuit$
<code>\gamma</code>	$\gamma$	<code>\omega</code>	$\omega$	<code>\diamondsuit</code>	$\diamondsuit$
<code>\delta</code>	$\delta$	<code>\Gamma</code>	$\Gamma$	<code>\heartsuit</code>	$\heartsuit$
<code>\epsilon</code>	$\epsilon$	<code>\Delta</code>	$\Delta$	<code>\spadesuit</code>	$\spadesuit$



Character Sequence	Symbol	Character Sequence	Symbol	Character Sequence	Symbol
<code>\zeta</code>	$\zeta$	<code>\Theta</code>	$\Theta$	<code>\leftrightharrow</code>	$\leftrightarrow$
<code>\eta</code>	$\eta$	<code>\Lambda</code>	$\Lambda$	<code>\leftarrow</code>	$\leftarrow$
<code>\theta</code>	$\theta$	<code>\Xi</code>	$\Xi$	<code>\Leftarrow</code>	$\Leftarrow$
<code>\vartheta</code>	$\vartheta$	<code>\Pi</code>	$\Pi$	<code>\uparrow</code>	$\uparrow$
<code>\iota</code>	$\iota$	<code>\Sigma</code>	$\Sigma$	<code>\rightarrow</code>	$\rightarrow$
<code>\kappa</code>	$\kappa$	<code>\Upsilon</code>	$\Upsilon$	<code>\Rightarrow</code>	$\Rightarrow$
<code>\lambda</code>	$\lambda$	<code>\Phi</code>	$\Phi$	<code>\downarrow</code>	$\downarrow$
<code>\mu</code>	$\mu$	<code>\Psi</code>	$\Psi$	<code>\circ</code>	$\circ$
<code>\nu</code>	$\nu$	<code>\Omega</code>	$\Omega$	<code>\pm</code>	$\pm$
<code>\xi</code>	$\xi$	<code>\forall</code>	$\forall$	<code>\geq</code>	$\geq$
<code>\pi</code>	$\pi$	<code>\exists</code>	$\exists$	<code>\propto</code>	$\propto$
<code>\rho</code>	$\rho$	<code>\ni</code>	$\ni$	<code>\partial</code>	$\partial$
<code>\sigma</code>	$\sigma$	<code>\cong</code>	$\cong$	<code>\bullet</code>	$\bullet$
<code>\varsigma</code>	$\varsigma$	<code>\approx</code>	$\approx$	<code>\div</code>	$\div$
<code>\tau</code>	$\tau$	<code>\Re</code>	$\Re$	<code>\neq</code>	$\neq$
<code>\equiv</code>	$\equiv$	<code>\oplus</code>	$\oplus$	<code>\aleph</code>	$\aleph$
<code>\Im</code>	$\Im$	<code>\cup</code>	$\cup$	<code>\wp</code>	$\wp$
<code>\otimes</code>	$\otimes$	<code>\subseteq</code>	$\subseteq$	<code>\oslash</code>	$\oslash$
<code>\cap</code>	$\cap$	<code>\in</code>	$\in$	<code>\supseteq</code>	$\supseteq$
<code>\supset</code>	$\supset$	<code>\lceil</code>	$\lceil$	<code>\subset</code>	$\subset$
<code>\int</code>	$\int$	<code>\cdot</code>	$\cdot$	<code>\o</code>	$\o$

# Text Properties

---

Character Sequence	Symbol	Character Sequence	Symbol	Character Sequence	Symbol
<code>\rfloor</code>	⌋	<code>\neg</code>	¬	<code>\nabla</code>	∇
<code>\lfloor</code>	⌊	<code>\times</code>	×	<code>\ldots</code>	...
<code>\perp</code>	⊥	<code>\surd</code>	√	<code>\prime</code>	′
<code>\wedge</code>	∧	<code>\varpi</code>	ϖ	<code>\O</code>	∅
<code>\rceil</code>	⌈	<code>\rangle</code>	⟩	<code>\mid</code>	
<code>\vee</code>	∨			<code>\copyright</code>	©
<code>\langle</code>	⟨				

You can also specify stream modifiers that control font type and color. The first four modifiers are mutually exclusive. However, you can use `\fontname` in combination with one of the other modifiers:

- `\bf` — Bold font
- `\it` — Italic font
- `\sl` — Oblique font (rarely available)
- `\rm` — Normal font
- `\fontname{fontname}` — Specify the name of the font family to use.
- `\fontsize{fontsize}` — Specify the font size in FontUnits.
- `\color{colorSpec}` — Specify color for succeeding characters

Stream modifiers remain in effect until the end of the string or only within the context defined by braces { }.

## Specifying Text Color in TeX Strings

Use the `\color` modifier to change the color of characters following it from the previous color (which is black by default). Syntax is:

- `\color{colorname}` — Use for the eight basic named colors (red, green, yellow, magenta, blue, black, white), and plus the four Simulink colors (gray, darkGreen, orange, and lightBlue).

Note that short names (one-letter abbreviations) for colors are not supported by the `\color` modifier.

- `\color[rgb]{r g b}` — Use to specify an RGB triplet with values between 0 and 1 as a cell array

For example:

```
text(.1,.5,['\fontsize{16}black '...
 '{\color{magenta}magenta '...
 '\color[rgb]{0 .5 .5}teal '...
 '\color{red}red} black again'])
```

# Text Properties

---

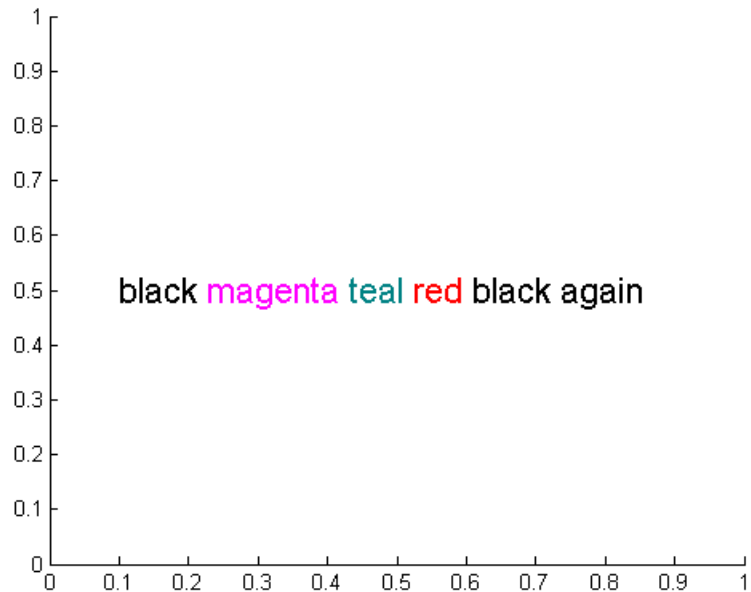

## Specifying Subscript and Superscript Characters

The subscript character “`_`” and the superscript character “`^`” modify the character or substring defined in braces immediately following.

To print the special characters used to define the TeX strings when Interpreter is `tex`, prefix them with the backslash “`\`” character: `\{`, `\}`, `\_`, `\^`.

See the “Examples” on page 1-6977 in the text reference page for more information.

When Interpreter is `none`, no characters in the String are interpreted, and all are displayed when the text is drawn.

When Interpreter is `latex`, MATLAB provides a complete LaTeX interpreter for text objects. See the Interpreter property for more information.

## Tag

string

*User-specified object label.* Provides a means to identify graphics objects with a user-specified label. The default is an empty string.

Use the `Tag` property and the `findobj` function to manipulate specific objects within a plotting hierarchy.

## Type

string (read-only)

*Class of graphics object.* String that identifies the class of the graphics object. Use this property to find all objects of a given type within a plotting hierarchy. For text objects, `Type` is always 'text'.

## UIContextMenu

handle of uicontextmenu object

*Associate a context menu with the text.* The handle of a `uicontextmenu` object created in the same figure as the text. Use the `uicontextmenu` function to create the context menu. MATLAB displays the context menu whenever you right-click over the text.

## Units

pixels | normalized | inches |  
| characters | centimeters | points | {data}

*Units of measurement.* Specifies the units MATLAB uses to interpret the `Extent` and `Position` properties. All units are measured from the lower left corner of the axes plot box.

- `normalized` — Units map the lower left corner of the rectangle defined by the axes to (0,0) and the upper right corner to (1.0,1.0).
- `pixels`, `inches`, `centimeters`, and `points` — Absolute units. 1 point =  $\frac{1}{72}$  inch.

# Text Properties

---

- `characters` — Based on the size of characters in the default system font. The width of one `characters` unit is the width of the letter `x`, and the height of one `characters` unit is the distance between the baselines of two lines of text.
- `data` — Data units of the parent axes as determined by the data graphed (not the axes `Units` property, which controls the positioning of the axes within the figure window).

If you change the value of `Units`, it is good practice to return it to its default value after completing your computation so as not to affect other functions that assume `Units` is set to the default value.

`UserData`  
matrix

*User-specified data.* Data you want to associate with the text object. The default value is an empty array. MATLAB does not use this data, but you can access it using the `set` and `get` commands.

`VerticalAlignment`  
`top` | `cap` | `{middle}` | `baseline` |  
`bottom`

*Vertical alignment of text.* Specifies the vertical justification of the text string. It determines where MATLAB places the string vertically with regard to the points specified by the `Position` property.

- `top` — Place the top of the string's `Extent` rectangle at the specified  $y$ -position.
- `cap` — Place the string so that the top of a capital letter is at the specified  $y$ -position.
- `middle` — Place the middle of the string at the specified  $y$ -position.
- `baseline` — Place font baseline at the specified  $y$ -position.

- `bottom` — Place the bottom of the string’s Extent rectangle at the specified `y`-position.

The following picture illustrates the alignment options.

**Text VerticalAlignment property viewed with the HorizontalAlignment property set to left (the default).**

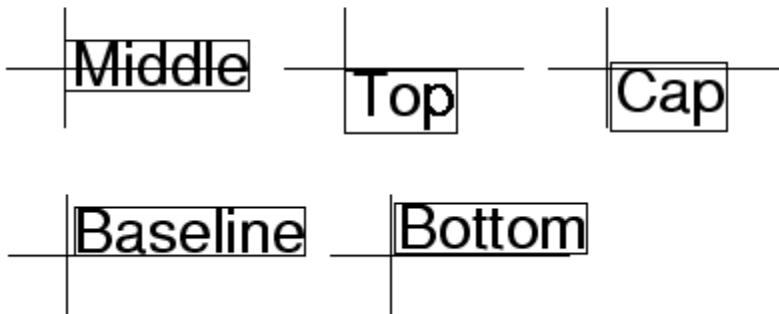

See “Text Alignment” for more information and examples.

`Visible`  
{on} | off

*Text visibility.* By default, all text is visible. When set to `off`, the text is not visible, but still exists, and you can query and set its properties.

**See Also**      `text`

# textread

---

## Purpose

Read data from text file; write to multiple outputs

---

**Note** textread is not recommended. Use textscan instead.

---

## Syntax

```
[A,B,C,...] = textread(filename,format)
[A,B,C,...] = textread(filename,format,N)
[...] = textread(...,param,value,...)
```

## Description

[A,B,C,...] = textread(filename,format) reads data from the file filename into the variables A,B,C, and so on, using the specified format, until the entire file is read. The filename and format inputs are strings, each enclosed in single quotes. textread is useful for reading text files with a known format. textread handles both fixed and free format files.

---

**Note** When reading large text files, reading from a specific point in a file, or reading file data into a cell array rather than multiple outputs, you might prefer to use the textscan function.

---

textread matches and converts groups of characters from the input. Each input field is defined as a string of non-white-space characters that extends to the next white-space or delimiter character, or to the maximum field width. Repeated delimiter characters are significant, while repeated white-space characters are treated as one.

The format string determines the number and types of return arguments. The number of return arguments is the number of items in the format string. The format string supports a subset of the conversion specifiers and conventions of the C language fscanf routine. Values for the format string are listed in the table below. White-space characters in the format string are ignored.



<b>format</b>	<b>Action</b>	<b>Output</b>
Literals (ordinary characters)	Ignore the matching characters. For example, in a file that has Dept followed by a number (for department number), to skip the Dept and read only the number, use 'Dept' in the format string.	None
%d	Read a signed integer value.	Double array
%u	Read an integer value.	Double array
%f	Read a floating-point value.	Double array
%s	Read a white-space or delimiter-separated string.	Cell array of strings
%q	Read a double quoted string, ignoring the quotes.	Cell array of strings
%c	Read characters, including white space.	Character array
%[...]	Read the longest string containing characters specified in the brackets.	Cell array of strings
%[^...]	Read the longest nonempty string containing characters that are not specified in the brackets.	Cell array of strings
%*... instead of %	Ignore the matching characters specified by *.	No output
%w... instead of %	Read field width specified by w. The %f format supports %w.pf, where w is the field width and p is the precision.	

[A,B,C,...] = textread(filename,format,N) reads the data, reusing the format string N times, where N is an integer greater than zero. If N is smaller than zero, textread reads the entire file.

[...] = textread(...,param,value,...) customizes textread using param/value pairs, as listed in the table below.

# textread

---

param	value	Action
bufsize	Positive integer	Specifies the maximum string length, in bytes. Default is 4095.
commentstyle	matlab	Ignores characters after %.
commentstyle	shell	Ignores characters after #.
commentstyle	c	Ignores characters between /* and */.
commentstyle	c++	Ignores characters after //.
delimiter	One or more characters	Act as delimiters between elements. Default is none.
emptyvalue	Scalar double	Value given to empty cells when reading delimited files. Default is 0.
endofline	Single character or '\r\n'	Character that denotes the end of a line. Default is determined from file
expchars	Exponent characters	Default is eEdD.
headerlines	Positive integer	Ignores the specified number of lines at the beginning of the file.
whitespace	Any from the list below: ' '           Space \b            Backspace \n            Newline \r            Carriage return \t            Horizontal tab	Treats vector of characters as white space. Default is '\b\t'.

---

**Note** When `textread` reads a consecutive series of `whitespace` values, it treats them as one white space. When it reads a consecutive series of `delimiter` values, it treats each as a separate delimiter.

---

**Tips**

If you want to preserve leading and trailing spaces in a string, use the `whitespace` parameter as shown here:

```
textread('myfile.txt', '%s', 'whitespace', '')
ans =
 ' An example of preserving spaces '
```

**Examples****Example 1 – Read All Fields in Free Format File Using %**

The first line of `mydata.dat` is

```
Sally Level1 12.34 45 Yes
```

Read the first line of the file as a free format file using the % format.

```
[names, types, x, y, answer] = textread('mydata.dat', ...
 '%s %s %f %d %s', 1)
```

returns

```
names =
 'Sally'
types =
 'Level1'
x =
 12.340000000000000
y =
 45
answer =
 'Yes'
```

**Example 2 – Read as Fixed Format File, Ignoring the Floating Point Value**

The first line of `mydata.dat` is

```
Sally Level1 12.34 45 Yes
```

Read the first line of the file as a fixed format file, ignoring the floating-point value.

```
[names, types, y, answer] = textread('mydata.dat', ...
'%9c %6s %*f %2d %3s', 1)
```

returns

```
names =
Sally
types =
 'Level1'
y =
 45
answer =
 'Yes'
```

`%*f` in the format string causes `textread` to ignore the floating point value, in this case, 12.34.

### **Example 3 – Read Using Literal to Ignore Matching Characters**

The first line of `mydata.dat` is

```
Sally Type1 12.34 45 Yes
```

Read the first line of the file, ignoring the characters `Type` in the second field.

```
[names, typenum, x, y, answer] = textread('mydata.dat', ...
'%s Type%d %f %d %s', 1)
```

returns

```
names =
 'Sally'
typenum =
 1
x =
 12.340000000000000
y =
 45
```

```
answer =
 'Yes'
```

Type%d in the format string causes the characters Type in the second field to be ignored, while the rest of the second field is read as a signed integer, in this case, 1.

#### Example 4 – Specify Value to Fill Empty Cells

For files with empty cells, use the emptyvalue parameter. Suppose the file data.csv contains:

```
1,2,3,4,,6
7,8,9,,11,12
```

Read the file using NaN to fill any empty cells:

```
data = textread('data.csv', '', 'delimiter', ',', ...
 'emptyvalue', NaN);
```

#### Example 5 – Read File into a Cell Array of Strings

Read the file fft.m into cell array of strings.

```
file = textread('fft.m', '%s', 'delimiter', '\n', ...
 'whitespace', '');
```

### See Also

textscan | dlmread | fscanff

# textscan

---

**Purpose** Read formatted data from text file or string

**Syntax** `C = textscan(fileID,formatSpec)`  
`C = textscan(fileID,formatSpec,N)`

`C = textscan(str,formatSpec)`  
`C = textscan(str,formatSpec,N)`

`C = textscan( ___,Name,Value)`

`[C,position] = textscan( ___)`

**Description** `C = textscan(fileID,formatSpec)` reads data from an open text file into cell array, `C`. The text file is indicated by the file identifier, `fileID`. Use `fopen` to open the file and obtain the `fileID` value. When you finish reading from a file, close the file by calling `fclose(fileID)`.

`textscan` attempts to match the data in the file to `formatSpec`, which is a string of conversion specifiers.

`C = textscan(fileID,formatSpec,N)` reads file data, using the `formatSpec` `N` times, where `N` is a positive integer. To read additional data from the file after `N` cycles, call `textscan` again using the original `fileID`. If you resume a text scan of a file by calling `textscan` with the same file identifier (`fileID`), then `textscan` automatically resumes reading at the point where it terminated the last read.

`C = textscan(str,formatSpec)` reads data from a string, `str` into cell array `C`. For strings, repeated calls to `textscan` restart the scan from the beginning each time. To restart a scan from the last position, request a `position` output.

`textscan` attempts to match the data in the string, `str`, to `formatSpec`, which is a string of conversion specifiers.

`C = textscan(str,formatSpec,N)` reads string data, using the `formatSpec` `N` times, where `N` is a positive integer.

`C = textscan( ___,Name,Value)` specifies options using one or more `Name,Value` pair arguments, in addition to any of the input arguments in the previous syntaxes.

`[C,position] = textscan( ___)` returns the file or string position at the end of the scan as the second output argument, using any of the input arguments in the previous syntaxes. For a file, this is the value that `ftell(fileID)` would return after calling `textscan`. For a string, `position` indicates how many characters `textscan` read.

## Input Arguments

### **fileID - File identifier**

numeric scalar

File identifier of an open text file, specified as a number. Before reading a file with `textscan`, you must use `fopen` to open the file and obtain the `fileID`.

### **Data Types**

double

### **formatSpec - Format of the data fields**

string

Format of the data fields, specified as a string of one or more conversion specifiers. When `textscan` reads a file or string, it attempts to match the data to the `formatSpec` string. If `textscan` fails to match a data field, it stops reading and returns all fields read before the failure.

The number of conversion specifiers determines the number of cells in output array, `C`.

### **Numeric Fields**

This table lists available conversion specifiers for numeric inputs.

<b>Numeric Input Type</b>	<b>Conversion Specifier</b>	<b>Output Class</b>
Integer, signed	%d	int32
	%d8	int8
	%d16	int16
	%d32	int32
	%d64	int64
Integer, unsigned	%u	uint32
	%u8	uint8
	%u16	uint16
	%u32	uint32
	%u64	uint64
Floating-point number	%f	double
	%f32	single
	%f64	double
	%n	double

## Character Fields

This table lists available conversion specifiers for character inputs.

<b>Character Strings</b>	<b>Conversion Specifier</b>	<b>Details</b>
Characters	%s	String
	%q	String, where double quotation marks indicate text to keep together
	%c	Any single character, including a delimiter



Character Strings	Conversion Specifier	Details
Pattern-matching strings	%[...]	Read only the characters inside the brackets up to the first nonmatching character. To include ] in the set, specify it first: %[ ]...].  Example: %[mus] reads 'summer ' as 'summ'.
	%[^...]	Exclude characters inside the brackets, reading until the first matching character. To exclude ], specify it first: %[^ ]...].  Example: %[^xrg] reads 'summer ' as 'summe'.

**Optional Operators**

Conversion specifiers in formatSpec can include optional operators, which appear in the following order (includes spaces for clarity):

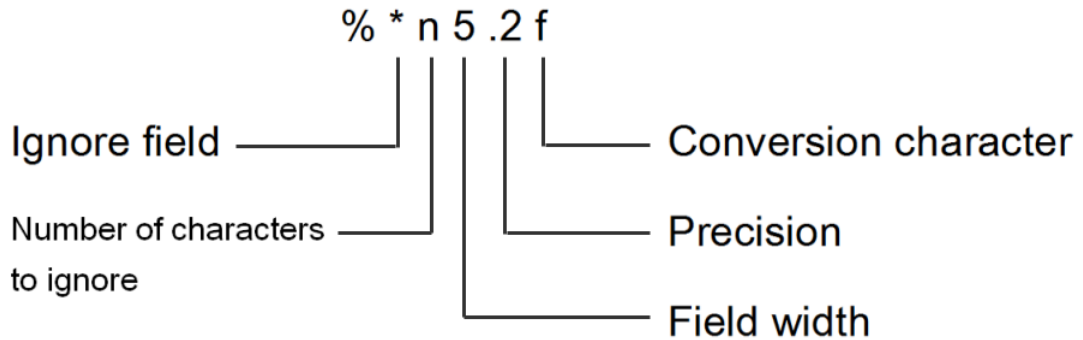

Optional operators include:

- Fields and Characters to Ignore

`textscan` reads all characters in your file in sequence, unless you tell it to ignore a particular field or a portion of a field.

Use the following operators to skip or read portions of fields.

Operator	Action Taken
<code>%*</code>	<p>Skip the field. <code>textscan</code> does not create an output cell for any field that it skips.</p> <p>Example: <code>'%s %*s %s %s %*s %*s %s'</code> (spaces are optional) converts the string <code>'Blackbird singing in the dead of night'</code> to four output cells with the strings <code>'Blackbird'</code> <code>'in'</code> <code>'the'</code> <code>'night'</code></p>
<code>%*n</code>	<p>Ignore <math>n</math> characters of the field, where <math>n</math> is an integer less than or equal to the number of characters in the field.</p> <p>Example: <code>%*4s</code> ignores 4 characters, so <code>'%*4s %s'</code> reads <code>'summer'</code> as <code>'er'</code>.</p>

- Field Width

`textscan` reads the number of characters or digits specified by the field width or precision, or up to the first delimiter, whichever comes first. A decimal point is counted as a digit. Specify the field width by inserting a number after the percent character (%) in the conversion specifier.

Example: `%5f` reads `'123.456'` as `123.4`.

---

**Note** When the field width operator is used with single characters (`%c`), `textscan` also reads delimiter characters.

Example: `%7c` reads 7 characters, including white-space, so `'Day and night'` reads as `'Day and'`.

---

- Precision

For floating-point numbers (`%n`, `%f`, `%f32`, `%f64`), you can specify the number of decimal digits to read.

Example: `%7.2f` reads `'123.456'` as `123.45`.

- Literal Text to Ignore

`textscan` ignores specified text appended to the `formatSpec` string.

Example: `Level%u8` reads `'Level1'` as `1`.

Example: `%u8Step` reads `'2Step'` as `2`.

### **N - Number of times to apply formatSpec**

integer

Number of times to apply `formatSpec`, specified as an integer.

### **Data Types**

single | double | int8 | int16 | int32 | int64 | uint8 |  
uint16 | uint32 | uint64

### **str - Input string**

string

Input string to read.

### **Name-Value Pair Arguments**

Specify optional comma-separated pairs of `Name`, `Value` arguments. `Name` is the argument name and `Value` is the corresponding value. `Name` must appear inside single quotes (`' '`). You can specify several name and value pair arguments in any order as `Name1, Value1, ..., NameN, ValueN`.

Names are not case sensitive.

**Example:** `C =`

```
textscan(fileID,formatSpec,'HeaderLines',3,'Delimiter','(',')')
skips the first three lines of the data, and then reads the remaining
data, treating commas as a delimiter.
```

## **'CollectOutput' - Logical indicator determining data concatenation**

false (default) | true

Logical indicator determining data concatenation, specified as the comma-separated pair consisting of 'CollectOutput' and either true or false. If true, then textscan concatenates consecutive output cells of the same fundamental MATLAB class into a single array.

## **'CommentStyle' - Symbols designating text to ignore**

string | cell array of strings

Symbols designating text to ignore, specified as the comma-separated pair consisting of 'CommentStyle' and a string or cell array of strings.

For example, specify a string such as '%' to ignore characters following the string on the same line. Specify a cell array of two strings, such as {'/\*', '\*/'}, to ignore characters between the strings.

textscan checks for comments only at the start of each field, not within a field.

**Example:** 'CommentStyle',{'/\*', '\*/'}

## **'Delimiter' - Field delimiter characters**

{' ', '\b', '\t'} (default) | string | cell array of strings

Field delimiter characters, specified as the comma-separated pair consisting of 'Delimiter' and a string or a cell array of strings. Specify multiple delimiters in a cell array of strings.

**Example:** 'delimiter',{';', '\*'}

textscan interprets repeated delimiter characters as separate delimiters, and returns an empty value to the output cell.

Within each row of data, the default field delimiter is white space. White space can be any combination of space (' '), backspace ('\b'), or tab ('\t') characters. If you do not specify a delimiter, textscan interprets repeated white-space characters as a single delimiter.

When you specify one of the following escape sequences as a delimiter, textscan converts that sequence to the corresponding control character:

<code>\b</code>	Backspace
<code>\n</code>	Newline
<code>\r</code>	Carriage return
<code>\t</code>	Tab
<code>\\</code>	Backslash ( <code>\</code> )

### **'EmptyValue' - Returned value for empty numeric fields**

`NaN` (default) | scalar

Returned value for empty numeric fields in delimited text files, specified as the comma-separated pair consisting of `'EmptyValue'` and a scalar.

### **'EndOfLine' - End-of-line characters**

string

End-of-line characters, specified as the comma-separated pair consisting of `'EndOfLine'` and a string. The default end-of-line sequence depends on the format of your file and can include a newline character (`'\n'`), a carriage return (`'\r'`), or a combination of the two (`'\r\n'`).

If there are missing values and an end-of-line sequence at the end of the last line in a file, then `textscan` returns empty values for those fields. This ensures that individual cells in output cell array, `C`, are the same size.

### **'ExpChars' - Exponent characters**

`'eEdD'` (default) | string

Exponent characters, specified as the comma-separated pair consisting of `'ExpChars'` and a string. The default exponent characters are `e`, `E`, `d`, and `D`.

### **'HeaderLines' - Number of header lines**

`0` (default) | positive integer

Number of header lines, specified as the comma-separated pair consisting of 'HeaderLines' and a positive integer. `textscan` skips the header lines, including the remainder of the current line.

### **'MultipleDelimsAsOne' - Multiple delimiter handling**

0 (false) (default) | 1 (true)

Multiple delimiter handling, specified as the comma-separated pair consisting of 'MultipleDelimsAsOne' and either true or false. If true, `textscan` treats consecutive delimiters as a single delimiter. Repeated delimiters separated by white-space are also treated as a single delimiter. You must also specify the `Delimiter` option.

**Example:** 'MultipleDelimsAsOne',1

### **'ReturnOnError' - Behavior when textscan fails to read or convert**

1 (true) (default) | 0 (false)

Behavior when `textscan` fails to read or convert, specified as the comma-separated pair consisting of 'ReturnOnError' and either true or false. If true, `textscan` terminates without an error and returns all fields read. If false, `textscan` terminates with an error and does not return an output cell array.

### **'TreatAsEmpty' - Strings to treat as empty value**

string | cell array of strings

Strings to treat as empty values, specified as the comma-separated pair consisting of 'TreatAsEmpty' and a single string or cell array of strings. This option only applies to numeric fields.

### **'Whitespace' - White-space characters**

' \b\t' (default) | string

White-space characters, specified as the comma-separated pair consisting of 'Whitespace' and a string of one or more characters. `textscan` adds a space character, `char(32)`, to any specified

Whitespace, unless Whitespace is empty ( ' ') and formatSpec includes any string conversion specifier.

When you specify one of the following escape sequences as any white-space character, textscan converts that sequence to the corresponding control character:

<code>\b</code>	Backspace
<code>\n</code>	Newline
<code>\r</code>	Carriage return
<code>\t</code>	Tab
<code>\\</code>	Backslash (\)

## Output Arguments

### **C - File or string data**

cell array

File or string data, returned as a cell array.

For each numeric conversion specifier in formatSpec, the textscan function returns a K-by-1 MATLAB numeric vector to the output cell array, C, where K is the number of times that textscan finds a field matching the specifier.

For each string conversion specifier in formatSpec, the textscan function returns a K-by-1 cell vector of strings, where K is the number of times that textscan finds a field matching the specifier. For each character conversion that includes a field width operator, textscan returns a K-by-M character array, where M is the field width.

### **position - File or string position**

integer

File or string position at the end of the scan, returned as an integer of class double. For a file, ftell(fileID) would return the same value after calling textscan. For a string, position indicates how many characters textscan read.

## Examples

### Read a String

Read a string of floating-point numbers.

```
str = '0.41 8.24 3.57 6.24 9.27';
```

```
C = textscan(str,'%f');
```

The formatSpec string '%f' tells textscan to match each field in str to a double-precision floating-point number.

Display the contents of cell array C.

```
celldisp(C)
```

```
C{1} =
```

```
 0.4100
 8.2400
 3.5700
 6.2400
 9.2700
```

Read the same string, truncating each value to one decimal digit.

```
C = textscan(str,'%3.1f %*1d');
```

The specifier %3.1f indicates a field width of 3 digits and a precision of 1. textscan reads a total of 3 digits, including the decimal point and the 1 digit after the decimal point. The specifier, %\*1d, tells textscan to skip the remaining digit.

Display the contents of cell array C.

```
celldisp(C)
```

```
C{1} =
```

```
 0.4000
```



```

8.2000
3.5000
6.2000
9.2000

```

### Read Different Types of Data

Using a text editor, create a file `scan1.dat` that contains data in the following form:

```

09/12/2005 Level1 12.34 45 1.23e10 inf Nan Yes 5.1+3i
10/12/2005 Level2 23.54 60 9e19 -inf 0.001 No 2.2-.5i
11/12/2005 Level3 34.90 12 2e5 10 100 No 3.1+.1i

```

Open the file, and read each column with the appropriate conversion specifier.

```

fileID = fopen('scan1.dat');
C = textscan(fileID, '%s %s %f32 %d8 %u %f %f %s %f');
fclose(fileID);
celldisp(C)

```

```
C{1}{1} =
```

```
09/12/2005
```

```
C{1}{2} =
```

```
10/12/2005
```

```
C{1}{3} =
```

```
11/12/2005
```

```
C{2}{1} =
```

Level1

C{2}{2} =

Level2

C{2}{3} =

Level3

C{3} =

12.3400

23.5400

34.9000

C{4} =

45

60

12

C{5} =

4294967295

4294967295

200000

C{6} =

Inf  
-Inf  
10

C{7} =

NaN  
0.0010  
100.0000

C{8}{1} =

Yes

C{8}{2} =

No

C{8}{3} =

No

C{9} =

5.1000 + 3.0000i  
2.2000 - 0.5000i  
3.1000 + 0.1000i

textscan returns a 1-by-9 cell array C.

View the MATLAB data type of each of the cells in C.

C

C =

Columns 1 through 5

{3x1 cell} {3x1 cell} [3x1 single] [3x1 int8] [3x1 uint32]

Columns 6 through 9

[3x1 double] [3x1 double] {3x1 cell} [3x1 double]

For example, C{1} and C{2} are cell arrays. C{5} is of data type uint32, so the first two elements of C{5} are the maximum values for a 32-bit unsigned integer, or intmax('uint32').

## Remove a Literal String

Remove the text 'Level' from each field in the second column of the data from the previous example.

Match the literal string in the formatSpec input.

```
fileID = fopen('scan1.dat');
C = textscan(fileID, '%s Level%d %f32 %d8 %u %f %f %s %f');
fclose(fileID);
C{2}
```

ans =

1  
2  
3

View the MATLAB data type of the second cell in C.

```
class(C{2})
```

```
ans =
```

```
int32
```

The second cell of the 1-by-9 cell array, `C`, is now of data type `int32`.

### Skip the Remainder of a Line

Read the first column of the file in the previous example into a cell array, skipping the rest of the line.

```
fileID = fopen('scan1.dat');
dates = textscan(fileID, '%s %*[^\\n]');
fclose(fileID);
dates{1}
```

```
ans =
```

```
 '09/12/2005'
```

```
 '10/12/2005'
```

```
 '11/12/2005'
```

`textscan` returns a 1-by-1 cell array `dates`.

### Specify Delimiter and Empty Value Conversion

Using a text editor, create a comma-delimited file, `data.csv`, that contains

```
1, 2, 3, 4, , 6
7, 8, 9, , 11, 12
```

Read the file, converting empty cells to `-Inf`.

```
fileID = fopen('data.csv');
C = textscan(fileID, '%f %f %f %f %u8 %f', ...
'delimiter', ',', 'EmptyValue', -Inf);
fclose(fileID);
```

```
column4 = C{4}, column5 = C{5}
```

```
column4 =
```

```
 4
 -Inf
```

```
column5 =
```

```
 0
 11
```

`textscan` returns a 1-by-6 cell array, `C`. The `textscan` function converts the empty value in `C{4}` to `-Inf`, where `C{4}` is associated with a floating-point format. Because MATLAB represents unsigned integer `-Inf` as 0, `textscan` converts the empty value in `C{5}` to 0, and not `-Inf`.

## Read Custom Empty Value Strings and Comments

Using a text editor, create a comma-delimited file, `data2.csv`, that contains the lines

```
abc, 2, NA, 3, 4
// Comment Here
def, na, 5, 6, 7
```

Designate the input that `textscan` should treat as comments or empty values.

```
fileID = fopen('data2.csv');
C = textscan(fileID, '%s %n %n %n %n', 'delimiter', ',', '...',
 'treatAsEmpty', {'NA', 'na'}, 'commentStyle', '//');
fclose(fileID);
celldisp(C)
```

```
C{1}{1} =
abc
```

```
C{1}{2} =
def
```

```
C{2} =
 2
 NaN
```

```
C{3} =
 NaN
 5
```

```
C{4} =
 3
 6
```

```
C{5} =
 4
 7
```

### Treat Repeated Delimiters as One

Using a text editor, create a file, `data3.csv`, that contains

```
1,2,3,,4
5,6,7,,8
```

To treat the repeated commas as a single delimiter, use the `MultipleDelimsAsOne` parameter, and set the value to 1 (true).

```
fileID = fopen('data3.csv');
C = textscan(fileID,'%f %f %f %f','delimiter','',...
'MultipleDelimsAsOne',1);
fclose(fileID);
celldisp(C)
```

```
C{1} =
 1
 5
```

```
C{2} =
 2
 6
```

```
C{3} =
 3
 7
```

```
C{4} =
 4
 8
```

## Collect Numeric Data

Using a text editor, create a file, `grades.txt`, that contains:

Student_ID	Test1	Test2	Test3
1	91.5	89.2	77.3
2	88.0	67.8	91.0
3	76.3	78.1	92.5
4	96.4	81.2	84.6

Read the column headers using the format `'%s'` four times.

```
fileID = fopen('grades.txt');

formatSpec = '%s';
N = 4;
C_text = textscan(fileID,formatSpec,N,'delimiter','|');
```

Read the numeric data in the file.

```
C_data0 = textscan(fileID,'%d %f %f %f')

C_data0 =
 [4x1 int32] [4x1 double] [4x1 double] [4x1 double]
```



The default value for `CollectOutput` is 0 (false), so `textscan` returns each column of the numeric data in a separate array.

Set `CollectOutput` to 1 (true) to collect the consecutive columns of the same class into a single array.

```
frewind(fileID);

C_text = textscan(fileID, '%s', N, 'delimiter', '|');

C_data1 = textscan(fileID, '%d %f %f %f', 'CollectOutput', 1)

C_data1 =
 [4x1 int32] [4x3 double]
```

The test scores, which are all double, are collected into a single 4-by-3 array.

Close the file, `grades.txt`.

```
fclose(fileID);
```

### Read Nondefault Control Characters

Use `sprintf` to convert nondefault escape sequences in your data.

Create a string that includes a form feed character, `\f`. Then, to read the string using `textscan`, call `sprintf` to explicitly convert the form feed.

```
lyric = sprintf('Blackbird\fsinging\fin\fthe\fddead\fof\fnight');
C = textscan(lyric, '%s', 'delimiter', sprintf('\f'));
C{1}
```

```
ans =

 'Blackbird'
 'singing'
 'in'
 'the'
```

```
'dead'
'of'
'night'
```

textscan returns a 1-by-1 cell array, C.

## Resume a Text Scan of a String

Resume a scan of a string from a position other than the beginning.

If you resume a text scan of a string, textscan reads from the beginning of the string each time. To resume a scan from any other position in the string, use the two-output argument syntax in your initial call to textscan.

For example, create a string called lyric. Read the first word of the string, and then resume the scan.

```
lyric = 'Blackbird singing in the dead of night';
[firstword,pos] = textscan(lyric,'%9c',1);
lastpart = textscan(lyric(pos+1:end),'%s');
```

## Algorithms

textscan converts numeric fields to the specified output type according to MATLAB rules regarding overflow, truncation, and the use of NaN, Inf, and -Inf. For example, MATLAB represents an integer NaN as zero. If textscan finds an empty field associated with an integer format specifier (such as %d or %u), it returns the empty value as zero and not NaN.

textscan does not include leading white-space characters in the processing of any data fields. When processing numeric data, textscan also ignores trailing white space.

textscan imports any complex number as a whole into a complex numeric field, converting the real and imaginary parts to the specified numeric type (such as %d or %f). Valid forms for a complex number are:

±<real>±<imag>i|j                      Example: 5.7-3.1i

±<imag>i|j                              Example: -7j

Do not include embedded white space in a complex number. `textscan` interprets embedded white space as a field delimiter.

**See Also**

`dlmread` | `fread` | `fscanf` | `load` | `uiimport` | `xlsread` | `fopen` | `readtable`

**Related Examples**

- “Import Data from a Nonrectangular Text File”
- “Import Large Text File Data in Blocks”
- “Access Data in a Cell Array”

**Concepts**

- “Ways to Import Text Files”

# textwrap

---

**Purpose**            Wrapped string matrix for given uicontrol

**Syntax**            `outstring = textwrap(h,instring)`  
`outstring = textwrap(h,instring,columns)`  
`[outstring,position] = textwrap(...)`

**Description**      `outstring = textwrap(h,instring)` returns a wrapped string cell array, `outstring`, that fits inside the uicontrol with handle `h`. `instring` is a cell array, with each cell containing a single line of text. `outstring` is the wrapped string matrix in cell array format. Each cell of the input string is considered a paragraph.

`outstring = textwrap(h,instring,columns)` returns an `outstring` with each line wrapped at `columns` characters. Spaces are included in the character count.

`[outstring,position] = textwrap(...)` returns the recommended position of the uicontrol in the units of the uicontrol. `position` considers the extent of the multiline text in the *x* and *y* directions.

`textwrap` maintains the original line breaks in the input cell array and adds new ones. It can calculate uicontrol positions with any type of Units, including normalized units.

**Tips**                When programming a GUI, do not call `copyobj` or `textwrap` (which calls `copyobj`) inside a `CreateFcn`. The act of copying the uicontrol object fires the `CreateFcn` repeatedly, which raises a series of error messages after exceeding the root object's `RecursionLimit` property.

**Examples**           Place two text-wrapped strings in text uicontrols. The left one has a `Position` calculated by `textwrap` in Units of pixels; the right one's `Position` is calculated manually in Units of characters:

```
figure('Position',[560 528 350 250]);
% Make a text uicontrol to wrap in Units of Pixels
% Create it in Units of Pixels, 100 wide, 10 high
pos = [10 100 100 10];
ht = uicontrol('Style','Text','Position',pos);
```

```
string = {'This is a string for the left text uicontrol.',...
 'to be wrapped in Units of Pixels,',...
 'with a position determined by TEXTWRAP.'};
% Wrap string, also returning a new position for ht
[outstring,newpos] = textwrap(ht,string) %#ok<NOPRT>

outstring =
 'This is a string for'
 'the left text'
 'uicontrol.'
 'to be wrapped in'
 'Units of Pixels,'
 'with a position'
 'determined by'
 'TEXTWRAP.'

newpos =
 10 100 91 124

set(ht,'String',outstring,'Position',newpos)

% Make another text uicontrol to wrap to a column width of 15
colwidth = 15;
% Create it in Units of Pixels, 100 wide, 10 high
pos1 = [150 100 100 10];
ht1 = uicontrol('Style','Text','Position',pos1);
string1 = {'This is a string for the right text uicontrol.',...
 'to be wrapped in Units of Characters,',...
 'into lines 15 columns wide.'};
outstring1 = textwrap(ht1,string1,colwidth);
% Reset Units of ht1 to Characters to use the result
set(ht1,'Units','characters')
newpos1 = get(ht1,'Position')

newpos1 =
 29.8000 7.6154 20.0000 0.7692
```

# textwrap

---

```
% Set new Position in Characters to be specified colwidth
% with height the length of the outstring1 cell array + 1.
newpos1(3) = colwidth;
newpos1(4) = length(outstring1)+1

newpos1 =
 29.8000 7.6154 15.0000 10.0000

set(ht1,'String',outstring1,'Position',newpos1)
```

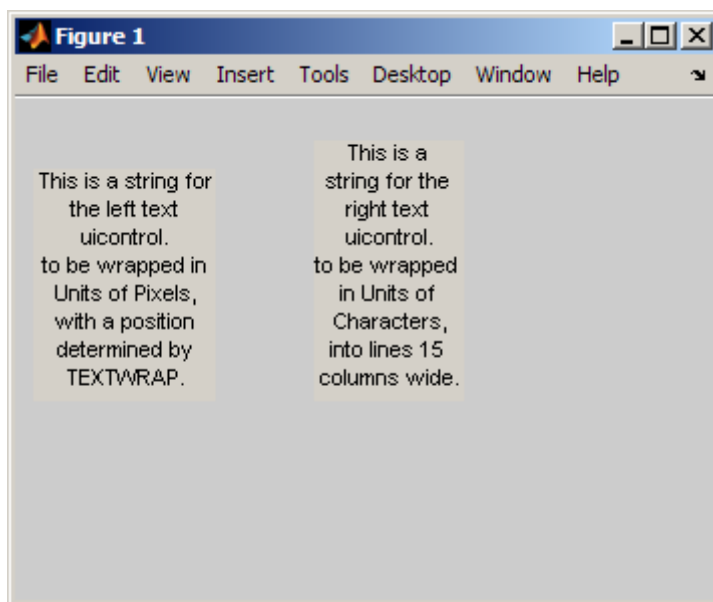

## See Also

[align](#) | [uicontrol](#)

**Purpose** Transpose-free quasi-minimal residual method

**Syntax**

```
x = tfqmr(A,b)
x = tfqmr(afun,b)
x = tfqmr(a,b,tol)
x = tfqmr(a,b,tol,maxit)
x = tfqmr(a,b,tol,maxit,m)
x = tfqmr(a,b,tol,maxit,m1,m2,x0)
[x,flag] = tfqmr(A,B,...)
[x,flag,relres] = tfqmr(A,b,...)
[x,flag,relres,y]y(A,b,...)
[x,flag,relres,iter,resvec] = tfqmr(A,b,...)
```

**Description** `x = tfqmr(A,b)` attempts to solve the system of linear equations  $A*x=b$  for  $x$ . The  $n$ -by- $n$  coefficient matrix  $A$  must be square and the right-hand side column vector  $b$  must have length  $n$ .

`x = tfqmr(afun,b)` accepts a function handle, `afun`, instead of the matrix  $A$ . The function, `afun(x)`, accepts a vector input  $x$  and returns the matrix-vector product  $A*x$ . In all of the following syntaxes, you can replace  $A$  by `afun`. “Parameterizing Functions” explains how to provide additional parameters to the function `afun`.

`x = tfqmr(a,b,tol)` specifies the tolerance of the method. If `tol` is `[]` then `tfqmr` uses the default,  $1e-6$ .

`x = tfqmr(a,b,tol,maxit)` specifies the maximum number of iterations. If `maxit` is `[]` then `tfqmr` uses the default,  $\min(N,20)$ .

`x = tfqmr(a,b,tol,maxit,m)` and `x = tfqmr(a,b,tol,maxit,m1,m2)` use preconditioners  $m$  or  $m=m1*m2$  and effectively solve the system  $A*inv(M)*x = B$  for  $x$ . If  $M$  is `[]` then a preconditioner is not applied.  $M$  may be a function handle `mfun` such that `mfun(x)` returns  $m\backslash x$ .

`x = tfqmr(a,b,tol,maxit,m1,m2,x0)` specifies the initial guess. If `x0` is `[]` then `tfqmr` uses the default, an all zero vector.

`[x,flag] = tfqmr(A,B,...)` also returns a convergence flag:

Flag	Convergence
0	tfqmr converged to the desired tolerance tol within maxit iterations.
1	tfqmr iterated maxit times but did not converge.
2	Preconditioner m was ill-conditioned.
3	tfqmr stagnated. (Two consecutive iterates were the same.)
4	One of the scalar quantities calculated during tfqmr became too small or too large to continue computing.

`[x,flag,relres] = tfqmr(A,b,...)` also returns the relative residual norm  $\text{norm}(b-A*x)/\text{norm}(b)$ . If flag is 0, then  $\text{relres} \leq \text{tol}$ .

`[x,flag,relres,y]y(A,b,...)` also returns the iteration number at which x was computed:  $0 \leq \text{iter} \leq \text{maxit}$ .

`[x,flag,relres,iter,resvec] = tfqmr(A,b,...)` also returns a vector of the residual norms at each iteration, including  $\text{norm}(b-A*x_0)$ .

## Examples

### Using tfqmr with Matrix or Function Handle Input

This example shows how to use tfqmr with a matrix input and with a function input.

```
n = 100; on = ones(n,1);
A = spdiags([-2*on 4*on -on],-1:1,n,n);
b = sum(A,2);
tol = 1e-8;
maxit = 15;
M1 = spdiags([on/(-2) on],-1:0,n,n);
M2 = spdiags([4*on -on],0:1,n,n);
x = tfqmr(A,b,tol,maxit,M1,M2,[]);
```

You can also use a matrix-vector product function as input:

```
function y = afun(x,n)
```



```
y = 4 * x;
y(2:n) = y(2:n) - 2 * x(1:n-1);
y(1:n-1) = y(1:n-1) - x(2:n);
x1 = tfqmr(@(x)afun(x,n),b,tol,maxit,M1,M2);
```

If `applyOp` is a function suitable for use with `qmr`, it may be used with `tfqmr` by wrapping it in an anonymous function:

```
x1 = tfqmr(@(x)applyOp(x,'notransp'),b,tol,maxit,M1,M2);
```

### Using tfqmr with a Preconditioner

This example demonstrates the use of a preconditioner.

Load `A = west0479`, a real 479-by-479 nonsymmetric sparse matrix.

```
load west0479;
A = west0479;
```

Define `b` so that the true solution is a vector of all ones.

```
b = full(sum(A,2));
```

Set the tolerance and maximum number of iterations.

```
tol = 1e-12; maxit = 20;
```

Use `tfqmr` to find a solution at the requested tolerance and number of iterations.

```
[x0,f10,rr0,it0,rv0] = tfqmr(A,b,tol,maxit);
```

`f10` is 1 because `tfqmr` does not converge to the requested tolerance `1e-12` within the requested 20 iterations. The seventeenth iterate is the best approximate solution and is the one returned as indicated by `it0 = 17`. MATLAB® stores the residual history in `rv0`.

Plot the behavior of `tfqmr`.

```
semilogy(0:maxit,rv0(1:maxit+1)/norm(b),'-o');
```

```
xlabel('Iteration number');
ylabel('Relative residual');
```

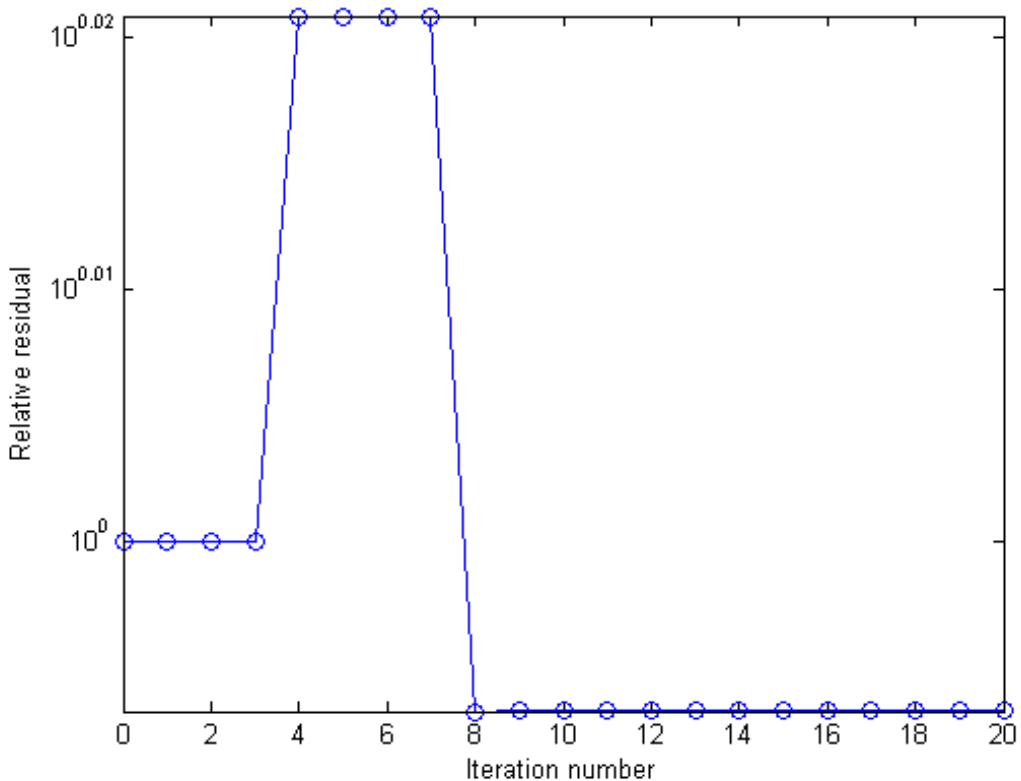

Note that like `bicgstab`, `tfqmr` keeps track of half iterations. The plot shows that the solution does not converge. You can use a preconditioner to improve the outcome.

Create the preconditioner with `ilu`, since the matrix `A` is nonsymmetric.

```
[L,U] = ilu(A,struct('type','ilutp','droptol',1e-5));
```

Error using ilu

There is a pivot equal to zero. Consider decreasing the drop tolerance or consider using the 'udiag' option.

MATLAB cannot construct the incomplete LU as it would result in a singular factor, which is useless as a preconditioner.

You can try again with a reduced drop tolerance, as indicated by the error message.

```
[L,U] = ilu(A,struct('type','ilutp','droptol',1e-6));
[x1,f11,rr1,it1,rv1] = tfqmr(A,b,tol,maxit,L,U);
```

f11 is 0 because tfqmr drives the relative residual to  $4.1410e-014$  (the value of rr1). The relative residual is less than the prescribed tolerance of  $1e-12$  at the sixth iteration (the value of it1) when preconditioned by the incomplete LU factorization with a drop tolerance of  $1e-6$ . The output rv1(1) is norm(b), and the output rv1(7) is norm(b-A\*x2).

You can follow the progress of tfqmr by plotting the relative residuals at each iteration starting from the initial estimate (iterate number 0).

```
semilogy(0:0.5:it1,rv1/norm(b),'-o');
xlabel('Iteration number');
ylabel('Relative residual');
```

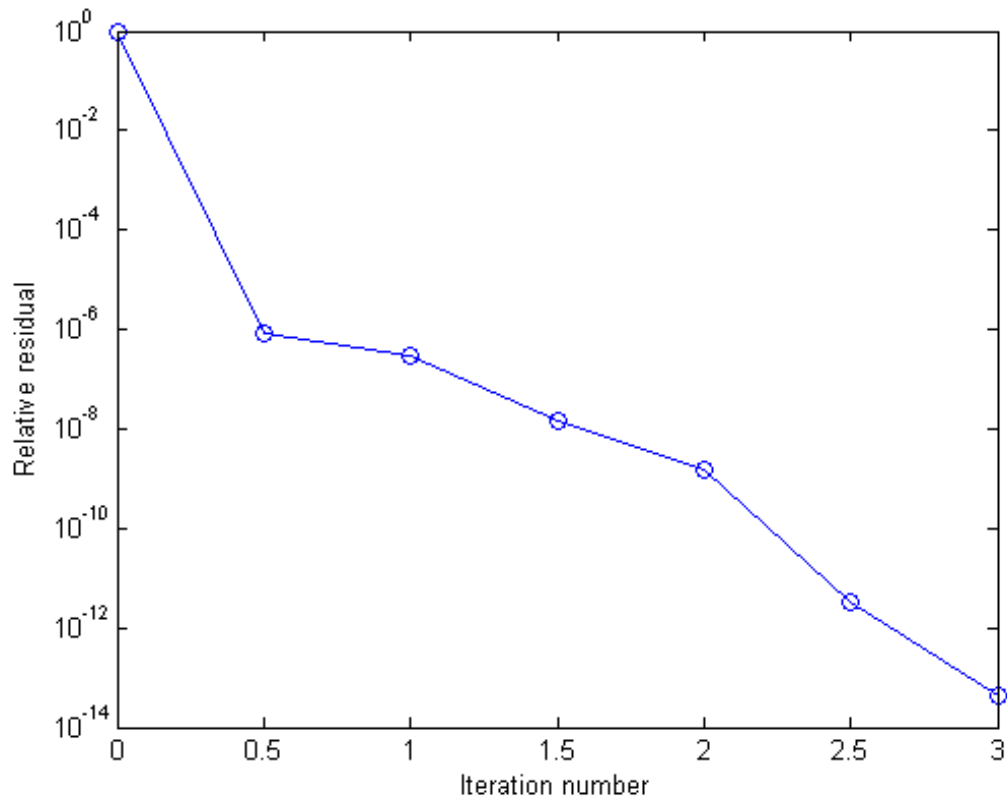

## See Also

`bicg` | `bicgstab` | `bicgstabl` | `cgs` | `function_handle` | `gmres` |  
`lsqr` | `ilu` | `minres` | `pcg` | `qmr` | `symmlq` | `mldivide`

**Purpose** Issue exception and terminate function

**Syntax** `throw(exception)`

**Description** `throw(exception)` issues an exception based on the information contained in *exception*. The exception terminates the currently running function and returns control to its caller. The *exception* argument is scalar object of the MException class that contains information on the cause of the error and where it occurred. The `throw` function passes *exception* back to the caller of the currently running function, and eventually back to the Command Window when the program terminates. The exception is made available to any calling function by means of the `try`, `catch` function, and to the Command Window by means of the `MException.last` function.

Unlike `throwAsCaller` and `rethrow`, the `throw` function also sets the *stack* field of the *exception* to the location from which `throw` was called.

**Tips** There are four ways to throw an exception in MATLAB (see the list below). Use the first of these when testing the outcome of some action for failure and reporting the failure to MATLAB. Use one of the remaining three techniques to throw an existing exception.

- 1** Test the result of some action taken by your program. If the result is found to be incorrect or unexpected, compose an appropriate message and message identifier, and pass these to MATLAB using the `error` function.
- 2** Reissue the original exception by throwing the initial exception unmodified. Use the MException `rethrow` method to do this.
- 3** Collect additional information on the cause of the error, store it in a new or modified exception, and issue a new exception based on that record. Use the MException `addCause` and `throw` methods to do this.

# throw (MException)

---

- 4 Make it appear that the error originated in the caller of the currently running function. Use the MException throwAsCaller method to do this.

## Examples

### Example 1

This example tests the output of function `evaluate_plots` and throws an exception if it is not acceptable:

```
[minval, maxval] = evaluate_plots(p24, p28, p41);
if minval < lower_bound || maxval > upper_bound
 exception = MException('VerifyOutput:OutOfBounds', ...
 'Results are outside the allowable limits');
 throw(exception);
end
```

### Example 2

This example attempts to open a file in a folder that is not on the MATLAB path. It uses a nested try-catch block to give the user the opportunity to extend the path. If the file still cannot be found, the program issues an exception with the first error appended to the second using `addCause`:

```
function data = read_it(filename);
try
 % Attempt to open and read from a file.
 fid = fopen(filename, 'r');
 data = fread(fid);
catch exception1
 % If the error was caused by an invalid file ID, try
 % reading from another location.
 if strcmp(exception1.identifier, 'MATLAB:FileIO:InvalidFid')
 msg = sprintf(...
 '\nCannot open file %s. Try another location? ', ...
 filename);
 reply = input(msg, 's')
 if reply(1) == 'y'
 newFolder = input('Enter folder name: ', 's');
```

```
else
 throw(exception1);
end
oldpath = addpath(newFolder);
try
 fid = fopen(filename, 'r');
 data = fread(fid);
catch exception2
 exception3 = addCause(exception2, exception1)
 path(oldpath);
 throw(exception3);
end
path(oldpath);
end
end
fclose(fid);

try
 d = read_it('anytextfile.txt');
catch exception
end

exception
exception =
MException object with properties:

 identifier: 'MATLAB:FileIO:InvalidFid'
 message: 'Invalid file identifier. Use fopen
 to generate a valid file identifier.'
 stack: [1x1 struct]
 cause: {[1x1 MException]}
```

Cannot open file anytextfile.txt. Try another location?  
Enter folder name: xxxxxxx  
Warning: Name is nonexistent or not a directory: xxxxxxx.  
> In path at 110  
In addpath at 89

# throw (MException)

---

## See Also

throwAsCaller(MException) | last(MException) |  
getReport(MException) | addCause(MException) |  
rethrow(MException) | assert | error | MException | try, catch



# throwAsCaller (MException)

---

**Purpose** Throw exception as if from calling function

**Syntax** `throwAsCaller(exception)`

**Description** `throwAsCaller(exception)` throws an exception from the currently running function based on the *exception* input, a scalar object of the `MException` class. The MATLAB software exits the currently running function and returns control to either the keyboard or an enclosing catch block in a calling function. Unlike the `throw` function, MATLAB omits the current stack frame from the `stack` field of the `MException`, thus making the exception look as if it is being thrown by the caller of the function.

In some cases, it is not relevant to show the person running your program the true location that generated an exception, but is better to point to the calling function where the problem really lies. You might also find `throwAsCaller` useful when you want to simplify the error display, or when you have code that you do not want made public.

## Tips

There are four ways to throw an exception in MATLAB (see the list below). Use the first of these when testing the outcome of some action for failure and reporting the failure to MATLAB. Use one of the remaining three techniques to throw an existing exception.

- 1** Test the result of some action taken by your program. If the result is found to be incorrect or unexpected, compose an appropriate message and message identifier, and pass these to MATLAB using the `error` function.
- 2** Reissue the original exception by throwing the initial exception unmodified. Use the `MException` `rethrow` method to do this.
- 3** Collect additional information on the cause of the error, store it in a new or modified exception, and issue a new exception based on that record. Use the `MException` `addCause` and `throw` methods to do this.

## throwAsCaller (MException)

---

- 4 Make it appear that the error originated in the caller of the currently running function. Use the MException throwAsCaller method to do this.

### Examples

The function `klein_bottle`, in this example, generates a Klein Bottle figure by revolving the figure-eight curve defined by `XYKLEIN`. It defines a few variables and calls the function `draw_klein`, which executes three functions in a `try`, `catch` block. If there is an error, the `catch` block issues an exception using either `throw` or `throwAsCaller`:

```
function klein_bottle(pq)
ab = [0 2*pi];
rtr = [2 0.5 1];
box = [-3 3 -3 3 -2 2];
vue = [55 60];
draw_klein(ab, rtr, pq, box, vue)

function draw_klein(ab, rtr, pq, box, vue)
clf
try
 tube('xyklein',ab, rtr, pq, box, vue);
 shading interp
 colormap(pink);
catch exception
 throw(exception)
% throwAsCaller(exception)
end
```

Call the `klein_bottle` function, passing a vector, and the function completes normally by drawing the figure.

```
klein_bottle([40 40])
```

Call the function again, this time passing a scalar value. Because the `catch` block issues the exception using `throw`, MATLAB displays error messages for line 16 of function `draw_klein`, and for line 6 of function `klein_bottle`:

## throwAsCaller (MException)

---

```
klein_bottle(40)
Error using klein_bottle>draw_klein (line 16)
Attempted to access pq(2); index out of bounds because numel(pq)=1.
```

```
Error in klein_bottle (line 6)
draw_klein(ab, rtr, pq, box, vue)
```

Run the function again, this time changing the `klein_bottle.m` file so that the `catch` block uses `throwAsCaller` instead of `throw`. This time, MATLAB only displays the error at line 6 of the main program:

```
klein_bottle(40)
Error using klein_bottle (line 6)
Attempted to access pq(2); index out of bounds because numel(pq)=1.
```

### See Also

```
last(MException) | getReport(MException) |
addCause(MException) | rethrow(MException) | throw(MException)
| assert | error | MException | try, catch
```

# tic

---

**Purpose** Start stopwatch timer

**Syntax**

```
tic
timerVal = tic
```

**Description** `tic` starts a stopwatch timer to measure performance. The function records the internal time at execution of the `tic` command. Display the elapsed time with the `toc` function.

`timerVal = tic` returns the value of the internal timer at the execution of the `tic` command, so that you can record time for simultaneous time spans.

- Tips**
- Consecutive `tic` commands overwrite the internally recorded starting time.
  - The `clear` function does not reset the starting time recorded by a `tic` command.
  - The following actions result in unexpected output:
    - Using `tic` and `toc` to time `timeit`
    - Using `tic` and `toc` within a function timed by `timeit`

**Output Arguments**

**timerVal**  
Value of the internal timer at the execution of the `tic` command. This value is used as an input argument for a subsequent call to `toc`. You should not rely on the meaning of this value.

**Examples** Measure time to generate two random matrices and compute element-by-element multiplication of their transposes.

```
tic
A = rand(12000, 4400);
B = rand(12000, 4400);
toc
C = A' .* B';
```

---

```
toc
```

---

Measure how the time required to solve a linear system varies with the order of a matrix:

```
t = zeros(1,100);
for n = 1:100
 A = rand(n,n);
 b = rand(n,1);
 tic;
 x = A\b;
 t(n) = toc;
end
plot(t)
```

---

Measure multiple time spans simultaneously using two pairs of tic/toc calls. To do this, measure the minimum and average time to compute a summation of Bessel functions:

```
REPS = 1000; minTime = Inf; nsum = 10;
tic; % TIC, pair 1

for i=1:REPS
 tStart = tic; % TIC, pair 2
 total = 0;
 for j=1:nsum
 total = total + besselj(j,REPS);
 end

 tElapsed = toc(tStart); % TOC, pair 2
 minTime = min(tElapsed, minTime);
end
averageTime = toc/REPS; % TOC, pair 1
```

## See Also

[clock](#) | [cputime](#) | [etime](#) | [profile](#) | [timeit](#) | [toc](#)

# timeit

---

**Purpose** Measure time required to run function

**Syntax**  
`t = timeit(f)`  
`t = timeit(f,numOutputs)`

**Description** `t = timeit(f)` measures the typical time (in seconds) required to run the function specified by the function handle `f`.

`t = timeit(f,numOutputs)` calls `f` with the desired number of outputs, `numOutputs`. By default, `timeit` calls the function `f` with one output (or no outputs, if the function does not return any outputs).

**Input Arguments** **f - function to be measured**  
function handle

Function to be measured, specified as a function handle. `f` is either a handle to a function that takes no input, or a handle to an anonymous function with an empty argument list.

**numOutputs - Number of desired outputs from f**  
integer

Number of desired outputs from `f`, specified as an integer. If the function specified by `f` has a variable number of outputs, `numOutputs` specifies which syntax `timeit` uses to call the function. For example, the `svd` function returns a single output, `s`, or three outputs, `[U,S,V]`. Set `numOutputs` to 1 to time the `s = svd(X)` syntax, or set it to 3 to time the `[U,S,V] = svd(X)` syntax.

**Algorithms** `timeit` calls the specified function multiple times, and computes the median of the measurements.

**Examples** **Determine Time to Obtain Current Date**

Use `timeit` to time a function call to `date`. This example uses a handle to a function that accepts no input.

```
f = @date;
t = timeit(f)
```

```
t =
```

```
1.3481e-04
```

### Determine Time to Compute Matrix Summation

Time the combination of several mathematical matrix operations: matrix transposition, element-by-element multiplication, and summation of columns.

```
A = rand(12000, 400);
B = rand(400, 12000);
f = @() sum(A.' .* B, 1);
timeit(f)
```

```
ans =
```

```
0.0427
```

### Compare Time to Run svd with Multiple Outputs

Determine how long it takes to run svd with one output argument, `s=svd(X)`.

```
X = [1 2; 3 4; 5 6; 7 8];
f = @() svd(X);
t1 = timeit(f)
```

```
t1 =
```

```
1.5427e-05
```

Compare the results to svd with three output arguments, `[U,S,V]=svd(X)`.

```
t2 = timeit(f,3)
```

```
t2 =

2.6695e-05
```

## Compare Time to Execute Custom Preallocation to Calling zeros

Create a short function to allocate a matrix using nested loops. Preallocating an array using a nested loop is inefficient, but is shown here for illustrative purposes.

```
function mArr = preAllocFcn(x,y)
for m = 1:x
 for n = 1:y
 mArr(m,n) = 0;
 end
end
end
```

Compare the time to allocate zeros to a matrix using nested loops and using the zeros function.

```
x = 1000;
y = 500;
g = @() preAllocFcn(x,y);
h = @() zeros(x,y);
diffRunTime = timeit(g)-timeit(h)
```

```
diffRunTime =

0.2004
```

## Tips

- The following actions result in unexpected output:
  - Using `timeit` between `tic` and `toc`
  - Using `timeit` to time a function that includes calls to `tic` and `toc`
  - Using `timeit` recursively



**See Also**

`function_handle` | `tic` | `toc` | `cputime`

**Concepts**

- Anonymous Functions
  - Analyzing Your Program's Performance
- MATLAB Performance Measurement White Paper on MATLAB Central File Exchange

**Purpose** Read elapsed time from stopwatch

**Syntax**

```
toc
elapsedTime = toc
toc(timerVal)
elapsedTime = toc(timerVal)
```

**Description** `toc` reads the elapsed time from the stopwatch timer started by the `tic` function. The function reads the internal time at the execution of the `toc` command, and displays the elapsed time since the most recent call to the `tic` function that had no output, in seconds.

`elapsedTime = toc` returns the elapsed time in a variable.

`toc(timerVal)` displays the time elapsed since the `tic` command corresponding to `timerVal`.

`elapsedTime = toc(timerVal)` returns the elapsed time since the `tic` command corresponding to `timerVal`.

## Tips

- Consecutive calls to the `toc` function with no input return the elapsed since the most recent `tic`. Therefore, you can take multiple measurements from a single point in time.

Consecutive calls to the `toc` function with the same `timerVal` input return the elapsed time since the `tic` function call that corresponds to that input.

- The following actions result in unexpected output:
  - Using `tic` and `toc` to time `timeit`
  - Using `tic` and `toc` within a function timed by `timeit`

## Input Arguments

### **timerVal**

Value of the internal timer saved from a previous call to the `tic` command.

## Output Arguments

### **elapsedTime**

Scalar double representing the time elapsed between `tic` and `toc` commands, in seconds.

## Examples

Measure time to generate two random matrices and compute element-by-element multiplication of their transposes.

```
tic
A = rand(12000, 4400);
B = rand(12000, 4400);
toc
C = A' .* B';
toc
```

---

Measure how the time required to solve a linear system varies with the order of a matrix:

```
t = zeros(1,100);
for n = 1:100
 A = rand(n,n);
 b = rand(n,1);
 tic;
 x = A\b;
 t(n) = toc;
end
plot(t)
```

---

Measure multiple time spans simultaneously using two pairs of `tic/toc` calls. To do this, measure the minimum and average time to compute a summation of Bessel functions:

```
REPS = 1000; minTime = Inf; nsum = 10;
tic; % TIC, pair 1
```

```
for i=1:REPS
 tStart = tic; % TIC, pair 2
 total = 0;
 for j=1:nsum
 total = total + besselj(j,REPS);
 end

 tElapsed = toc(tStart); % TOC, pair 2
 minTime = min(tElapsed, minTime);
end
averageTime = toc/REPS; % TOC, pair 1
```

## See Also

[clock](#) | [cputime](#) | [etime](#) | [profile](#) | [tic](#) | [timeit](#)

## Purpose

MATLAB Gateway to LibTIFF library routines

## Description

The `Tiff` class represents a connection to a Tagged Image File Format (TIFF) file and provides access to many of the capabilities of the LibTIFF library. Use the methods of the `Tiff` object to call routines in the LibTIFF library. While you can use the `imread` and `imwrite` functions to read and write TIFF files, the `Tiff` class offers capabilities that these functions don't provide, such as reading subimages, writing tiles and strips of image data, and modifying individual TIFF tags.

In most cases, the syntax of the `Tiff` method is similar to the syntax of the corresponding LibTIFF library function. To get the most out of the `Tiff` object, you must be familiar with the LibTIFF API, as well as the TIFF specification and technical notes. View this documentation at [LibTIFF - TIFF Library and Utilities](#).

MATLAB supports LibTIFF version 4.0.0.

For copyright information, see the `libtiffcopyright.txt` file.

## Construction

`obj = Tiff(filename,mode)` creates a `Tiff` object associated with the TIFF file `filename`. `mode` specifies the type of access to the file.

A TIFF file is made up of one or more image file directories (IFDs). An IFD contains image data and associated metadata. IFDs can also contain subIFDs which also contain image data and metadata. When you open a TIFF file for reading, the `Tiff` object makes the first IFD in the file the *current* IFD. `Tiff` methods operate on the current IFD. You can use `Tiff` object methods to navigate among the IFDs and the subIFDs in a TIFF file.

When you open a TIFF file for writing or appending, the `Tiff` object automatically creates a IFD in the file for writing subsequent data. This IFD has all the default values specified in TIFF Revision 6.0.

When creating a new TIFF file, before writing any image to the file, you must create certain required fields (tags) in the file. These tags include `ImageWidth`, `ImageHeight`, `BitsPerSample`, `SamplesPerPixel`, `Compression`, `PlanarConfiguration`, and `Photometric`. If the image data has a stripped layout, the IFD contains the `RowsPerStrip` tag. If

the image data has a tiled layout, the IFD contains the `TileWidth` and `TileHeight` tags. Use the `setTag` method to define values for these tags.

## Input Arguments

### filename

Text string specifying name of file.

### mode

One of the following text strings specifying the type of access to the TIFF file.

## Supported Values

Parameter	Description
'r'	Open file for reading (default)
'w'	Open file for writing; discard existing contents
'w8'	Open file for writing a BigTIFF file; discard existing contents
'a'	Open or create file for writing; append data to end of file.
'r+'	Open (do not create) file for reading and writing

## Properties

### Compression

Specify scheme used to compress image data

This property defines all the supported values for this tag. You use this property to specify the value you want to assign to the tag, using the `setTag` method. For more clarification, see the example.

## Supported Values

None
CCITTRLE (Read-only)
CCITTFax3
CCITTFax4
LZW
JPEG
CCITTRLEW (Read-only)
PackBits
SGILog
SGILog24
Deflate
AdobeDeflate (Same as deflate)

Example: Set the `Compression` tag to the value `JPEG`. Note how you use the property to specify the value.

```
tiffobj.setTag('Compression', Tiff.Compression.JPEG);
```

## ExtraSamples

Describe extra components

This property defines all the supported values for this tag. You use this property to specify the value you want to assign to the tag, using the `setTag` method. For more clarification, see the example.

This field is required if there are extra channels in addition to the usual colormetric channels.

## Supported Values

Value of ExtraSamples	Description
Unspecified	Unspecified data
AssociatedAlpha	Associated alpha (pre-multiplied)
UnassociatedAlpha	Unassociated alpha data

Example: Set the ExtraSamples tag to the value AssociatedAlpha. Note how you use the property to specify the value.

```
tiffobj.setTag('ExtraSamples', Tiff.ExtraSamples.AssociatedAlpha);
```

See Also “Specify Tiff object properties and describe alpha channel” on page 1-7081

## Group3Options

Options for Group 3 Fax Compression

This property defines all the supported values for this tag. You use this property to specify the value you want to assign to the tag, using the setTag method. For more clarification, see the example.

This property is also referred to as Fax3 and T4Options. This value is a bit mask controlled by the first three bits.

## Supported Values

Supported values include the following.



Encoding2D	Bit 0 is 1. This specifies two-dimensional coding. If more than one strip is specified, each strip must begin with a one-dimensionally coded line. That is, RowsPerStrip should be a multiple of Parameter K, as documented in the CCITT specification.
Uncompressed	Bit 1 is 1. This specifies an uncompressed mode when encoding.
FillBits	Bit 2 is 1. Fill bits are added as necessary before EOL codes such that EOL always ends on a byte boundary. This ensures an EOL-sequence of 1 byte preceded by a zero nibble, for example, xxxx-0000 0000-0001.

Example:

```
mask = bitor(Tiff.Group3Options.Encoding2D,Tiff.Group3Options.Uncompressed);
tiffobj.setTag('Group3Options',mask);
```

### **InkSet**

Specify set of inks used in separated image

This property defines all the supported values for this tag. You use this property to specify the value you want to assign to the tag, using the `setTag` method. For more clarification, see the example.

In this context, separated refers to photometric interpretation, not the planar configuration.

## Supported Values

CMYK	Order of components: cyan, magenta, yellow, black. Usually, a value of 0 represents 0% ink coverage and a value of 255 represents 100% ink coverage for that component, but consult the TIFF specification for <code>DotRange</code> . When you specify CMYK, do not set the <code>InkNames</code> tag.
MultiInk	Any ordering other than CMYK. Consult the TIFF specification for <code>InkNames</code> field for a description of the inks used.

Example:

```
tiffobj.setTag('InkSet', Tiff.InkSet.CMYK);
```

## JPEGColorMode

Specify control of YCbCr/RGB conversion

Use these values only when the photometric interpretation is YCbCr.

This property should not be used for the purpose of reading YCbCr imagery as RGB. In this case, use the RGBA interface provided by the `readRGBAImage`, `readRGBAStrip`, and `readRGBATile` methods.

## Supported Values

Raw (default)	Keep input as separate Y, Cb, and Cr matrices.
RGB	Convert RGB input to YCbCr.

Example:

```
tiffobj.setTag('JPEGColorMode', Tiff/JPEGColorMode.RGB);
```

See also “Create YCbCr/JPEG image from RGB data” on page 1-7081

## Orientation

Specify visual orientation of the image data.

This property defines all the supported values for this tag. You use this property to specify the value you want to assign to the tag, using the `setTag` method. For more clarification, see the example.

The first row represents the top of the image, and the first column represents the left side. Support for this tag is for informational purposes only, and it does not affect how MATLAB reads or writes the image data.

## Supported Values

TopLeft
TopRight
BottomRight
BottomLeft
LeftTop
RightTop
RightBottom
LeftBottom

Example:

```
tiffobj.setTag('Orientation', Tiff.Orientation.TopRight);
```

## Photometric

Specify color space of image data

This property defines all the supported values for this tag. You use this property to specify the value you want to assign to the tag, using the `setTag` method. For more clarification, see the example.

## Supported Values

MinIsWhite
MinIsBlack
RGB
Palette
Mask
Separated (CMYK)
YCbCr
CIELab
ICCLab
ITULab
LogL
LogLUV
CFA
LinearRaw

Example:

```
tiffobj.setTag('Photometric', Tiff.Photometric.RGB);
```

## PlanarConfiguration

Specifies how image data components are stored on disk

This property defines all the supported values for this tag. You use this property to specify the value you want to assign to the tag, using the `setTag` method. For more clarification, see the example.

### Supported Values

Chunky	Store component values for each pixel contiguously. For example, in the case of RGB data, the first three pixels would be stored in the file as RGBRGBRGB etc. Almost all TIFF images have contiguous planar configurations.
Separate	Store component values for each pixel separately. For example, in the case of RGB data, the red component would be stored separately in the file from the green and blue components.

Example:

```
tiffobj.setTag('PlanarConfiguration', Tiff.PlanarConfiguration.CHUNKY);
```

### ResolutionUnit

Specify unit of measure used to interpret the XResolution and YResolution tags.

This property defines all the supported values for this tag. You use this property to specify the value you want to assign to the tag, using the `setTag` method. For more clarification, see the example.

### Supported Values

None (default)
Inch
Centimeter

Example: Set ResolutionUnit tag to the value Inch. Then, setting XResolution tag to 300 means pixels per inch.

```
tiffObj.setTag('ResolutionUnit', Tiff.ResolutionUnit.Inch);
tiffObj.setTag('XResolution', 300);
```

```
tiffObj.setTag('YResolution', 300);
```

## SampleFormat

Specify how to interpret each pixel sample

This property defines all the supported values for this tag. You use this property to specify the value you want to assign to the tag, using the `setTag` method. For more clarification, see the examples.

### Supported Values

UInt (default)
Int
IEEEFP

Void, ComplexInt, and ComplexIEEEFP are not supported.

Example:

```
tiffObj.setTag('SampleFormat', Tiff.SampleFormat.IEEFP);
```

## SGILogDataFmt

Specify control of client data for SGILog codec

This property defines all the supported values for this tag. You use this property to specify the value you want to assign to the tag, using the `setTag` method. For more clarification, see the example.

These enumerated values should only be used when the photometric interpretation value is `LogL` or `LogLUV`. The `BitsPerSample`, `SamplesPerPixel`, and `SampleFormat` tags should not be set if the image type is `LogL` or `LogLuv`. The choice of `SGILogDataFmt` will set these tags automatically. The `Float` and `Bits8` settings imply a `SamplesPerPixel` value of 3 for `LogLUV` images, but only 1 for `LogL` images.

### Supported Values

Float	Single precision samples
Bits8	uint8 samples (read only)

This tag can be set only once per instance of a LogL/LogLuv Tiff image object instance.

Example:

```
tiffobj = Tiff('example.tif','r');
tiffobj.setDirectory(3); % image three is a LogLuv image
tiffobj.setTag('SGILogDataFmt', Tiff.SGILogDataFmt.Float);
imdata = tiffobj.read();
```

### SubFileType

Specify type of image

This property defines all the supported values for this tag. You use this property to specify the value you want to assign to the tag, using the `setTag` method. For more clarification, see the example.

SubFileType is a bitmask that indicates the type of the image.

### Supported Values

Default	Default value for single image file or first image.
ReducedImage	The current image is a thumbnail or reduced-resolution image that typically would be found in a sub-IFD.
Page	The image is a single image of a multi-image (or multipage) file.
Mask	The image is a transparency mask for another image in the file. The photometric interpretation value must be Photometric.Mask.

Example:

```
tiffobj.setTag('SubFileType', Tiff.SubFileType.Mask);
```

## TagID

List of recognized TIFF tag names with their ID numbers

This property identifies all the supported TIFF tags with their ID numbers. Use this property to specify a tag when using the `setTag` method. For example, `Tiff.TagID.ImageWidth` returns the ID of the `ImageWidth` tag. To get a list of the names of supported tags, use the `getTagNames` method.

Example:

```
tiffobj.setTag(Tiff.TagID.ImageWidth, 300);
```

## Thresholding

Specifies technique used to convert from gray to black and white pixels.

This property defines all the supported values for this tag. You use this property to specify the value you want to assign to the tag, using the `setTag` method. For more clarification, see the example.

### Supported Values

BiLevel (default)
HalfTone
ErrorDiffuse

Example:

```
tiffobj.setTag('Thresholding', Tiff.Thresholding.HalfTone);
```

## YCbCrPositioning

Specify relative positioning of chrominance samples



This property defines all the supported values for this tag. You use this property to specify the value you want to assign to the tag, using the `setTag` method. For more clarification, see the example.

This property identifies all supported values for the `YCbCrPositioning` tag.

### Supported Values

Centered	Specify for compatibility with industry standards such as PostScript Level 2
Cosited	Specify for compatibility with most digital video standards such as CCIR Recommendation 601-1.

Example:

```
tiffobj.setTag('YCbCrPositioning', Tiff.YCbCrPositioning.Centered)
```

## Methods

<code>close</code>	Close Tiff object
<code>computeStrip</code>	Index number of strip containing specified coordinate
<code>computeTile</code>	Index number of tile containing specified coordinates
<code>currentDirectory</code>	Index of current IFD
<code>getTag</code>	Value of specified tag
<code>getTagNames</code>	List of recognized TIFF tags
<code>getVersion</code>	LibTIFF library version
<code>isTiled</code>	Determine if tiled image
<code>lastDirectory</code>	Determine if current IFD is last in file
<code>nextDirectory</code>	Make next IFD current IFD

<code>numberOfStrips</code>	Total number of strips in image
<code>numberOfTiles</code>	Total number of tiles in image
<code>read</code>	Read entire image
<code>readEncodedStrip</code>	Read data from specified strip
<code>readEncodedTile</code>	Read data from specified tile
<code>readRGBAImage</code>	Read image using RGBA interface
<code>readRGBAStrip</code>	Read strip data using RGBA interface
<code>readRGBATile</code>	Read tile data using RGBA interface
<code>rewriteDirectory</code>	Write modified metadata to existing IFD
<code>setDirectory</code>	Make specified IFD current IFD
<code>setSubDirectory</code>	Make subIFD specified by byte offset current IFD
<code>setTag</code>	Set value of tag
<code>write</code>	Write entire image
<code>writeDirectory</code>	Create new IFD and make it current IFD
<code>writeEncodedStrip</code>	Write data to specified strip
<code>writeEncodedTile</code>	Write data to specified tile

## Examples

### Create New TIFF File Using `Tiff` object

Create a new file called `myfile.tif`. To run this example, your directory must be writable.

```
t = Tiff('myfile.tif', 'w');
```

Close the `Tiff` object.

```
t.close();
```

### **Specify Tiff object properties and describe alpha channel**

Create an array of data, `data`, that contains colormetric channels and an alpha channel.

```
rgb = imread('example.tif');
numrows = size(rgb,1);
numcols = size(rgb,2);
alpha = 255*ones([numrows numcols], 'uint8');
data = cat(3,rgb,alpha);
```

Create a Tiff object, `t`, and set the object properties. Set the value of the `ExtraSamples` tag because the data contains the alpha channel in addition to the colormetric channels.

```
t = Tiff('myfile.tif','w');
t.setTag('Photometric',Tiff.Photometric.RGB);
t.setTag('Compression',Tiff.Compression.None);
t.setTag('BitsPerSample',8);
t.setTag('SamplesPerPixel',4);
t.setTag('SampleFormat',Tiff.SampleFormat.UInt);
t.setTag('ExtraSamples',Tiff.ExtraSamples.Unspecified);
t.setTag('ImageLength',numrows);
t.setTag('ImageWidth',numcols);
t.setTag('TileLength',32);
t.setTag('TileWidth',32);
t.setTag('PlanarConfiguration',Tiff.PlanarConfiguration.Chunky);
```

Write the data to the Tiff object.

```
t.write(data);
t.close();
```

### **Create YCbCr/JPEG image from RGB data**

Get RGB data.

# Tiff

---

```
rgb = imread('example.tif');
```

Create a Tiff object, `t`, and set the object properties. Specify RGB input data using the `JPEGColorMode` property.

```
t = Tiff('myfile.tif','w');
t.setTag('Photometric',Tiff.Photometric.YCbCr);
t.setTag('Compression',Tiff.Compression.JPEG);
t.setTag('YCbCrSubSampling',[2 2]);
t.setTag('BitsPerSample',8);
t.setTag('SamplesPerPixel',3);
t.setTag('SampleFormat',Tiff.SampleFormat.UInt);
t.setTag('ImageLength',size(rgb,1));
t.setTag('ImageWidth',size(rgb,2));
t.setTag('TileLength',32);
t.setTag('TileWidth',32);
t.setTag('PlanarConfiguration',Tiff.PlanarConfiguration.Chunky);
t.setTag('JPEGColorMode',Tiff.JPEGColorMode.RGB);
t.setTag('JPEGQuality',75);
```

Write the data to the Tiff object.

```
t.write(rgb);
t.close();
```

## See Also

`imread` | `imwrite` | `imfinfo`

## Tutorials

- “Exporting Image Data and Metadata to TIFF Files”
- “Reading Image Data and Metadata from TIFF Files”

**Purpose**

Create object to schedule execution of MATLAB commands

**Description**

Use a `timer` object to schedule the execution of MATLAB commands one or multiple times. If you schedule the timer to execute multiple times, you can define the time between executions and how to handle queuing conflicts.

The `timer` object uses callback functions to execute commands. Callback functions execute code during some event. For the `timer` object, you can specify the callback function as a function handle or as a string. If the callback function is a string, MATLAB evaluates it as executable code. The timer object supports callback functions when a timer starts (`StartFcn`), executes (`TimerFcn`), stops (`StopFcn`), or encounters an error (`ErrorFcn`).

---

**Note** The `timer` object is subject to the limitations of your hardware, operating system, and software. Avoid using timer objects for real-time applications.

---

**Construction**

`t = timer` creates an empty timer object to schedule execution of MATLAB commands. An error occurs if the timer starts and `TimerFcn` is not defined.

`t = timer(Name,Value)` creates a timer object with additional options that you specify using one or more `Name,Value` pair arguments.

**Input Arguments****Name-Value Pair Arguments**

Specify optional comma-separated pairs of `Name,Value` arguments. `Name` is the argument name and `Value` is the corresponding value. `Name` must appear inside single quotes ( ' '). You can specify several name and value pair arguments in any order as `Name1,Value1,...,NameN,ValueN`.

# timer

---

The argument name, `Name`, corresponds to a `timer` property name. In the constructor, the property values are specified using `Name, Value` pair arguments.

## **BusyMode**

String that indicates action taken when a timer has to execute `TimerFcn` before the completion of previous execution of the `TimerFcn`. When `Running='on'`, `BusyMode` is read only. This table summarizes the busy modes.

<b>BusyMode Values</b>	<b>Behavior if Queue Empty</b>	<b>Behavior if Queue Not Empty</b>	<b>Notes</b>
'drop'	Adds task to queue	Drops task	Possible skipping of <code>TimerFcn</code>
'error'	Adds task to queue	Completes task; throws error specified by <code>ErrorFcn</code> ; stops timer	Stops timer after completing task in execution queue
'queue'	Adds task to queue	Waits for queue to clear, and then enters task in queue	Adjusts <code>Period</code> property to manage tasks in execution queue

See “Handling Timer Queuing Conflicts” for more information.

**Default:** 'drop'

## **ErrorFcn**

String, function handle, or cell array defining the function that the timer executes when an error occurs. If there is an error, this function executes, and then calls StopFcn.

**ExecutionMode**

String that defines how the timer object schedules timer events. When Running='on', ExecutionMode is read only. This table summarizes the execution modes.

Execution Mode	Time Period Start Point
'singleShot'	In this mode, the timer callback function is only executed once. Therefore, the Period property has no effect. This is the default execution mode.
'fixedRate'	Starts immediately after the timer callback function is added to the MATLAB execution queue
'fixedDelay'	Starts when the timer function callback restarts execution after a time lag due to delays in the MATLAB execution queue
'fixedSpacing'	Starts when the timer callback function finishes executing.

- 'singleShot' is the single execution mode for the timer class, and is the default value.

**singleShot**

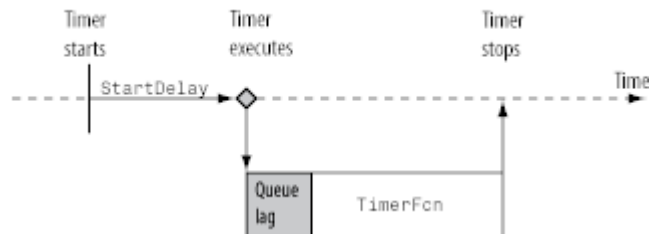

# timer

- 'fixedDelay', 'fixedRate', and 'fixedSpacing' are the three supported multiexecution modes. These modes define the starting point of the Period property. The Period property specifies the amount of time between executions, which remains the same. Only the point at which execution begins is different.

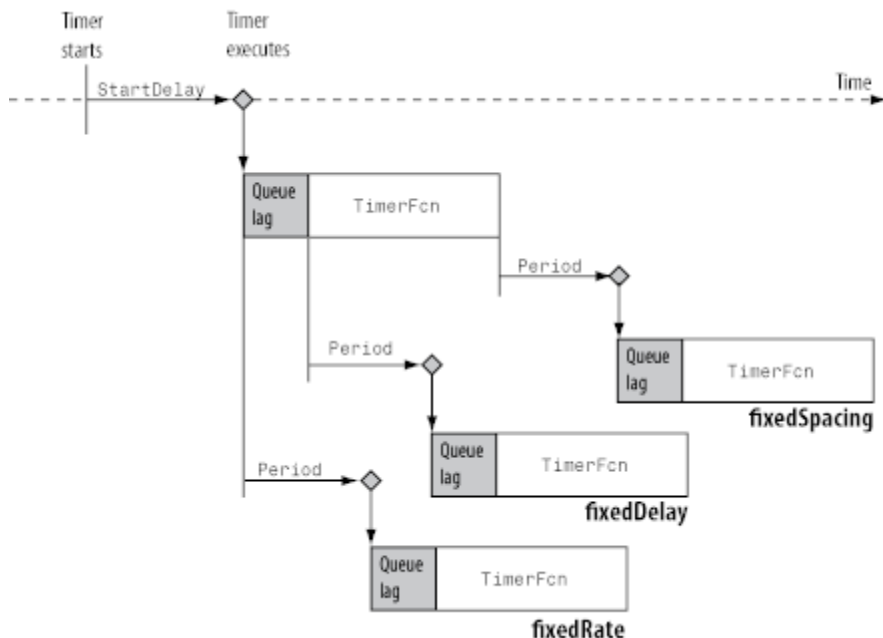

**Default:** 'singleShot'

## Name

String representing the timer name.

**Default:** 'timer-*i*', where *i* is a number indicating the *i*th timer object created this session. To reset *i* to 1, execute the `clear classes` command.



**ObjectVisibility**

String with possible values of 'on' or 'off', that provides a way for you to discourage end-user access to the timer objects your application creates. The `timerfind` function does not return an object whose `ObjectVisibility` property is set to 'off'. Objects that are not visible are still valid. To retrieve a list of all the timer objects in memory, including the invisible ones, use the `timerfindall` function.

**Default:** 'on'

**Period**

Number greater than 0.001 that specifies the delay, in seconds, between executions of `TimerFcn`. For the timer to use `Period`, you must set `ExecutionMode` and `TasksToExecute` to schedule multiple timer object callback events.

**Default:** 1.0

**StartDelay**

Number greater than or equal to 0 that specifies the delay, in seconds, between the start of the timer and the first execution of the function specified in `TimerFcn`. When `Running = 'on'`, `StartDelay` is read only.

**Default:** 0

**StartFcn**

String, function handle, or cell array defining the function that executes when the timer starts.

**StopFcn**

String, function handle, or cell array defining the function that executes when the timer stops. The timer stops when

- You call the timer stop method.
- The timer finishes executing `TimerFcn`. In other words, the value of `TasksExecuted` reaches the limit set by `TasksToExecute`.
- An error occurs. The `ErrorFcn` callback is called first, followed by the `StopFcn` callback.

You can use `StopFcn` to define clean up actions, such as deleting the timer object from memory.

## **Tag**

String that represents a label for the object.

## **TasksToExecute**

Number greater than 0, indicating the number of times the timer object is to execute the `TimerFcn` callback. Use the `TasksToExecute` property to set the number of executions. To use `TasksToExecute`, you must set `ExecutionMode` to schedule multiple timer callback events.

**Default:** `Inf`

## **TimerFcn**

String, function handle, or cell array defining the timer callback function. You must define this property before you can start the timer.

## **UserData**

Generic field for data that you want to add to the object.

## **Properties**

### **AveragePeriod**

Average time in seconds between `TimerFcn` executions since the timer started. Value is `NaN` until timer executes two timer callbacks.

**InstantPeriod**

The time in seconds between the last two executions of `TimerFcn`. Value is NaN until timer executes two timer callbacks.

**Running**

String defined as 'off' or 'on', indicating whether the timer is currently executing callback functions.

**TasksExecuted**

The number of times the timer called `TimerFcn` since the timer started.

**Type**

String that identifies the object type.

**Methods**

<code>delete</code>	Remove timer object from memory
<code>get</code>	Query property values for timer object
<code>isvalid</code>	Determine timer object validity
<code>set</code>	Set property values for timer object
<code>start</code>	Start timer object
<code>startat</code>	Schedule timer to fire at specified time
<code>stop</code>	Stop timer object
<code>timerfind</code>	Find timer object
<code>timerfindall</code>	Find timer object, regardless of visibility
<code>wait</code>	Block command prompt until timer stops running

## Copy Semantics

Handle. To learn how handle classes affect copy operations, see Copying Objects in the MATLAB documentation.

## Examples

### Display Message Using Timer

Display a message using an anonymous function as a callback function. It is important to note that the first two arguments the callback function passes are a handle to the timer object and an event structure. Even if the function doesn't use these arguments, the function definition requires them.

Wait 3 seconds, and then display the message '3 seconds have elapsed'.

```
t = timer;
t.StartDelay = 3;
t.TimerFcn = @(myTimerObj, thisEvent)disp('3 seconds have elapsed');
start(t)
```

```
3 seconds have elapsed
```

Suppose the function does not require the timer or event object. Use the tilde (~) operator to ignore the inputs.

```
t.TimerFcn = @(~,~) disp('3 seconds have elapsed');
start(t)
```

```
3 seconds have elapsed
```

Delete the timer object.

```
delete(t)
```

### Execute Callback Function Multiple Times

Display the event and date/time output when the timer starts, fires, and stops. The timer callback function will be executed 3 times with 2 seconds between calls. The first two arguments the callback function passes are a handle to the timer object and an event structure. The event structure contains two fields: Type is a string that identifies the

type of event that caused the callback, and `Data` is a structure that contains a date time vector of when the event occurred.

```
t = timer;
t.StartFcn = @(~,thisEvent)disp([thisEvent.Type ' executed '...
 datestr(thisEvent.Data.time,'dd-mmm-yyyy HH:MM:SS.FFF')]);
t.TimerFcn = @(~,thisEvent)disp([thisEvent.Type ' executed '...
 datestr(thisEvent.Data.time,'dd-mmm-yyyy HH:MM:SS.FFF')]);
t.StopFcn = @(~,thisEvent)disp([thisEvent.Type ' executed '...
 datestr(thisEvent.Data.time,'dd-mmm-yyyy HH:MM:SS.FFF')]);
t.Period = 2;
t.TasksToExecute = 3;
t.ExecutionMode = 'fixedRate';
start(t)
```

```
StartFcn executed 14-Mar-2013 09:08:50.865
TimerFcn executed 14-Mar-2013 09:08:50.865
TimerFcn executed 14-Mar-2013 09:08:52.865
TimerFcn executed 14-Mar-2013 09:08:54.866
StopFcn executed 14-Mar-2013 09:08:54.869
```

Delete the timer object.

```
delete(t)
```

## Define Custom Callback Functions

Create a timer object to remind yourself to take 30-second ergonomic breaks every 10 minutes over the course of 8 hours.

Create a function in a file named `createErgoTimer.m` that returns a timer object. Have this file include three local functions to handle timer start, execute, and stop tasks.

```
function t = createErgoTimer()
secondsBreak = 30;
secondsBreakInterval = 600;
```

# timer

---

```
secondsPerHour = 60^2;
secondsWorkTime = 8*secondsPerHour;

t = timer;
t.UserData = secondsBreak;
t.StartFcn = @ergoTimerStart;
t.TimerFcn = @takeBreak;
t.StopFcn = @ergoTimerCleanup;
t.Period = secondsBreakInterval+secondsBreak;
t.StartDelay = t.Period-secondsBreak;
t.TasksToExecute = ceil(secondsWorkTime/t.Period);
t.ExecutionMode = 'fixedSpacing';
end
```

Using `StartDelay` allows the timer to start without directing you to take a break immediately. Set the execution mode to `'fixedSpacing'` so that 10 minutes and 30 seconds (`t.Period`) elapses after the completion of a `TimerFcn` execution. This allows you to stretch for 30 seconds before the start of the next 10 minute interval.

In the `createErgoTimer.m` file, add a local function to handle the tasks associated with starting the timer. By default, the `timer` object passes itself and event data to the callback function. The function disregards the event data.

```
function ergoTimerStart(mTimer,~)
secondsPerMinute = 60;
secondsPerHour = 60*secondsPerMinute;
str1 = 'Starting Ergonomic Break Timer. ';
str2 = sprintf('For the next %d hours you will be notified',...
 round(mTimer.TasksToExecute*(mTimer.Period + ...
 mTimer.UserData)/secondsPerHour));
str3 = sprintf(' to take a %d second break every %d minutes.',...
 mTimer.UserData, (mTimer.Period - ...
 mTimer.UserData)/secondsPerMinute);
disp([str1 str2 str3]);
end
```

Add a local function to handle the tasks associated with executing the timer. The `TimerFcn` callback should tell you to take a 30 second break.

```
function takeBreak(mTimer,~)
disp('Take a 30 second break.')
end
```

Add a local function to handle the tasks associated with stopping the timer.

```
function ergoTimerCleanup(mTimer,~)
disp('Stopping Ergonomic Break Timer. ');
delete(mTimer)
end
```

Deleting the timer object removes it from memory.

From the command line, call the `createErgoTimer` function to create and start a timer.

```
t = createErgoTimer;
start(t)
```

```
Starting Ergonomic Break Timer. For the next 8 hours you will be notified.
```

```
Every 10 minutes, you will be reminded to take a 30 second break.
```

```
Take a break.
```

You can leave the timer running for 8 hours or stop it manually. Recall that you included the task of deleting the timer from memory in the `StopFcn` callback.

```
stop(t)
```

```
Stopping Ergonomic Break Timer.
```

# timer

---

## Tips

- To force the execution of the callback functions in the event queue, include a call to the `drawnow` function in your code. The `drawnow` function flushes the event queue.

## See Also

`function_handle`

## Concepts

- Timer Callback Functions
- “Handling Timer Queuing Conflicts”
- “Ignore Function Outputs”
- Property Attributes



<b>Purpose</b>	Remove timer object from memory
<b>Syntax</b>	<code>delete(t)</code>
<b>Description</b>	<p><code>delete(t)</code> removes the timer object, <code>t</code>, from memory. If <code>t</code> is an array of timer objects, <code>delete</code> removes all the objects from memory.</p> <p>When you delete a timer object, it becomes invalid and you cannot reuse it. If multiple references to a timer object exist in the workspace, deleting the timer object invalidates the remaining references. To remove invalid timer objects references from the workspace, use the <code>clear</code> command.</p>
<b>Tips</b>	<ul style="list-style-type: none"><li>• Use the <code>isvalid</code> method to determine if a timer object exists in memory, but is not cleared from the workspace.</li><li>• Use the <code>timerfind</code> and <code>timerfindall</code> methods to return timer objects currently existing in memory. This approach is useful if the reference to the timer object is cleared from the workspace (using the <code>clear</code> command), but not deleted from memory.</li></ul>
<b>Input Arguments</b>	<p><b>t</b></p> <p>Object of class <code>timer</code>.</p>
<b>Examples</b>	<p><b>Delete a Timer</b></p> <p>Create and start a timer that generates a 10-by-10 array of random numbers.</p> <pre>t = timer('TimerFcn','rand(10);'); start(t)</pre> <p>Delete the timer from memory.</p> <pre>delete(t)</pre> <p>Call the <code>whos</code> function to see if a reference still exists in the workspace.</p>

# timer.delete

---

```
whos
```

Name	Size	Bytes	Class	Attributes
ans	10x10	800	double	
t	1x1	104	timer	

Try to restart the timer.

```
start(t)
```

```
Error using timer/start (line 27)
Invalid timer object. This object has been deleted and should be removed
```

The timer cannot be restarted.

Clear the timer object reference from the workspace.

```
clear t
```

## Delete Multiple Timers Using `timerfind`

Use `delete` with the `timerfind` method to remove all visible timers from memory. This is an alternative to deleting individual timers by variable name.

Create and start three timers that compute the sine, cosine and tangent of  $\pi/4$ .

```
t1 = timer('TimerFcn','sin(pi/4);');
t2 = timer('TimerFcn','cos(pi/4);');
t3 = timer('TimerFcn','tan(pi/4);');
```

Delete the timers from memory using `timerfind`. This removes all visible timer objects from memory.

```
delete(timerfind);
```

## See Also

[timer](#) | [isvalid](#) | [timerfind](#) | [timerfindall](#)

**Purpose** Query property values for timer object

**Syntax**

```
get(t)
V = get(t)
V = get(t,propName)
```

**Description** `get(t)` queries property values for timer object, `t`, and displays all property names and current values. `t` must be a scalar timer object.

`V = get(t)` queries property values for timer object, `t` and returns a structure, `V`, where each field name is the name of a property of `t` and each field contains the value of that property. If `t` is an M-by-1 vector of timer objects, `V` is an M-by-1 array of structures.

`V = get(t,propName)` returns the value, `V`, of the timer object property specified in `propName`. If `propNames` is a vector cell array of `N` property names, and `t` is a vector of `M` timer objects, `v` is an M-by-N cell array of property values.

**Input Arguments**

**t**  
Object of class `timer`.

**propName**

String enclosed in single quotation marks that specifies a `timer` property.

**Examples**      **Display All Properties of Timer**

```
t = timer;
get(t)

AveragePeriod: NaN
 BusyMode: 'drop'
 ErrorFcn: ''
ExecutionMode: 'singleShot'
```

```
InstantPeriod: NaN
 Name: 'timer-1'
ObjectVisibility: 'on'
 Period: 1
 Running: 'off'
StartDelay: 0
StartFcn: ''
StopFcn: ''
 Tag: ''
TasksExecuted: 0
TasksToExecute: Inf
TimerFcn: ''
 Type: 'timer'
UserData: []
```

Delete the timer from memory.

```
delete(t)
```

## **Obtain Properties for Array of Timers**

Create three timers.

```
t1 = timer;
t2 = timer;
t3 = timer;
```

Get properties of an array of timers.

```
V = get([t1,t2,t3])
```

```
V =
```

3x1 struct array with fields:

```
AveragePeriod
BusyMode
ErrorFcn
ExecutionMode
```

```
InstantPeriod
Name
ObjectVisibility
Period
Running
StartDelay
StartFcn
StopFcn
Tag
TasksExecuted
TasksToExecute
TimerFcn
Type
UserData
```

Delete the timers from memory.

```
delete([t1,t2,t3])
```

### **Obtain Single Property for Timer**

Create a timer and determine if it is running.

```
t = timer;
get(t,'Running')
```

```
ans =
```

```
off
```

Delete the timer from memory.

```
delete(t)
```

### **Obtain Specified Properties for Array of Timers**

Create three timers.

```
t1 = timer;
t2 = timer;
```

# timer.get

---

```
t3 = timer;
```

Obtain name, period, and running property values from the array of timers.

```
V = get([t1,t2,t3],{'Name','Running','Period'})
```

```
V =
```

```
 'timer-1' 'off' [1]
 'timer-2' 'off' [1]
 'timer-3' 'off' [1]
```

## Alternatives

You can also use dot notation can also be used to query timer object properties. For example, `t.Running` returns the same value as `get(t,'Running')`.

## See Also

[timer](#) | [set](#)

**Purpose** Determine timer object validity

**Syntax** `validCheck = isvalid(t)`

**Description** `validCheck = isvalid(t)` determines timer object validity and returns a logical array, `validCheck`, that contains a 0 where the elements of `t` are invalid timer objects and a 1 where the elements of `t` are valid timer objects.

An invalid timer object is an object that is deleted from memory using `delete` and cannot be reused. Use the `clear` command to remove an invalid timer object from the workspace.

**Tips**

- To return timer objects existing in memory, use the `timerfind` and `timerfindall` methods. This practice is useful if the reference to the timer object is cleared from the workspace (using the `clear` function), but the object has not been deleted from memory.

**Input Arguments**

`t`  
Object or array of objects of class `timer`

## Examples

### Check Timer Object Validity

Create a timer object. While this timer object is valid, it cannot start because a `TimerFcn` is not defined.

```
t = timer;
out = isvalid(t)
```

```
out =
```

```
 1
```

Delete the timer object, making it invalid.

```
delete(t)
out1 = isvalid(t)
```

# timer.isvalid

---

```
out1 =
0
```

## See Also

`timer` | `delete` | `timerfind` | `timerfindall`



**Purpose**

Set property values for timer object

**Syntax**

```
set(t)
propStruct = set(t)

set(t,Name)
propCell = set(t,Name)
set(t,Name,Value)
set(t,S)
set(t,PN,PV)
```

**Description**

`set(t)` displays the property names and their possible values for all configurable properties of timer object `t`.

`propStruct = set(t)` returns the values in a struct.

`set(t,Name)` displays the possible values for the specified property, `Name`, of timer object, `t`.

`propCell = set(t,Name)` returns the values in a cell.

`set(t,Name,Value)` sets the properties specified by one or more `Name,Value` pair arguments. `t` can be a single timer object or a vector of timer objects, in which case `set` configures the property values for all timer objects, `t`.

`set(t,S)` configures the properties of `t`, with the values specified in `S`, where `S` is a structure whose field names are object property names.

`set(t,PN,PV)` configures the properties specified in the cell array of strings, `PN`, to the corresponding values in the cell array `PV`, for the timer object `t`.

## Input Arguments

**t**

Object of class `timer`.

**S**

Structure whose field names are `timer` property names.

**PN,PV**

Cell array of strings, `PN`, and corresponding cell array of values, `PV`. The cell array of `PN` must be a 1-by-`N` or `N`-by-1 array. If `t` is an array of `timer` objects, `PV` can be an `M`-by-`N` cell array, where `M` is equal to the length of `t` and `N` is equal to the length of `PN`. In this case, each `timer` object is updated with a different set of values for the list of property names contained in `PN`.

## Name-Value Pair Arguments

Specify optional comma-separated pairs of `Name`, `Value` arguments. `Name` is the argument name and `Value` is the corresponding value. `Name` must appear inside single quotes ( ' '). You can specify several name and value pair arguments in any order as `Name1,Value1,...,NameN,ValueN`.

## 'BusyMode'

String that indicates action taken when a timer has to execute `TimerFcn` before the completion of previous execution of the `TimerFcn`. When `Running='on'`, `BusyMode` is read only. This table summarizes the busy modes.

<b>BusyMode Values</b>	<b>Behavior if Queue Empty</b>	<b>Behavior if Queue Not Empty</b>	<b>Notes</b>
'drop'	Adds task to queue	Drops task	Possible skipping of <code>TimerFcn</code>
'error'	Adds task to queue	Completes task; throws error specified by <code>ErrorFcn</code> ; stops timer	Stops timer after completing task in execution queue
'queue'	Adds task to queue	Waits for queue to clear, and then enters task in queue	Adjusts <code>Period</code> property to manage tasks in execution queue

See “Handling Timer Queuing Conflicts” for more information.

**Default:** 'drop'

#### **'ErrorFcn'**

String, function handle, or cell array defining the function that the timer executes when an error occurs. If there is an error, this function executes, and then calls `StopFcn`.

#### **'ExecutionMode'**

String that defines how the timer object schedules timer events. When `Running='on'`, `ExecutionMode` is read only. This table summarizes the execution modes.

Execution Mode	Time Period Start Point
'singleShot'	In this mode, the timer callback function is only executed once. Therefore, the <code>Period</code> property has no effect. This is the default execution mode.
'fixedRate'	Starts immediately after the timer callback function is added to the MATLAB execution queue
'fixedDelay'	Starts when the timer function callback restarts execution after a time lag due to delays in the MATLAB execution queue
'fixedSpacing'	Starts when the timer callback function finishes executing.

- 'singleShot' is the single execution mode for the `timer` class, and is the default value.

### singleShot

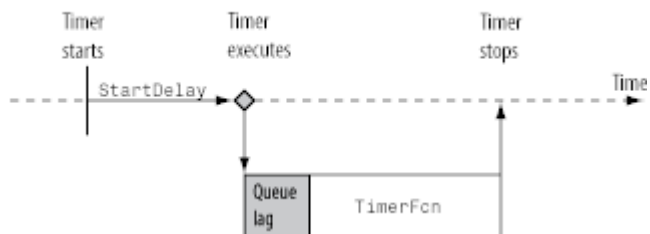

- 'fixedDelay', 'fixedRate', and 'fixedSpacing' are the three supported multiexecution modes. These modes define the starting point of the `Period` property. The `Period` property specifies the amount of time between executions, which remains the same. Only the point at which execution begins is different.

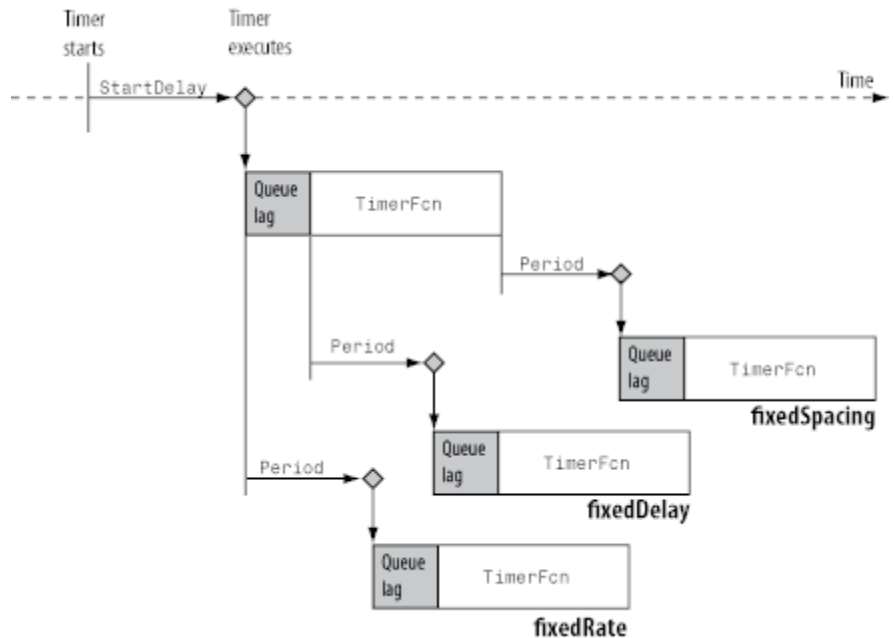

**Default:** 'singleShot'

## 'Name'

String representing the timer name.

**Default:** 'timer-*i*', where *i* is a number indicating the *i*th timer object created this session. To reset *i* to 1, execute the `clear classes` command.

## 'ObjectVisibility'

String with possible values of 'on' or 'off', that provides a way for you to discourage end-user access to the timer objects your application creates. The `timerfind` function does not return an object whose `ObjectVisibility` property is set to 'off'. Objects that are not visible are still valid. To retrieve a list of all the

timer objects in memory, including the invisible ones, use the `timerfindall` function.

**Default:** 'on'

## **'Period'**

Number greater than 0.001 that specifies the delay, in seconds, between executions of `TimerFcn`. For the timer to use `Period`, you must set `ExecutionMode` and `TasksToExecute` to schedule multiple timer object callback events.

**Default:** 1.0

## **'StartDelay'**

Number greater than or equal to 0 that specifies the delay, in seconds, between the start of the timer and the first execution of the function specified in `TimerFcn`. When `Running = 'on'`, `StartDelay` is read only.

**Default:** 0

## **'StartFcn'**

String, function handle, or cell array defining the function that executes when the timer starts.

## **'StopFcn'**

String, function handle, or cell array defining the function that executes when the timer stops. The timer stops when

- You call the timer stop method.
- The timer finishes executing `TimerFcn`. In other words, the value of `TasksExecuted` reaches the limit set by `TasksToExecute`.

- An error occurs. The `ErrorFcn` callback is called first, followed by the `StopFcn` callback.

You can use `StopFcn` to define clean up actions, such as deleting the timer object from memory.

**'Tag'**

String that represents a label for the object.

**'TasksToExecute'**

Number greater than 0, indicating the number of times the timer object is to execute the `TimerFcn` callback. Use the `TasksToExecute` property to set the number of executions. To use `TasksToExecute`, you must set `ExecutionMode` to schedule multiple timer callback events.

**Default:** `Inf`

**'TimerFcn'**

String, function handle, or cell array defining the timer callback function. You must define this property before you can start the timer.

**'UserData'**

Generic field for data that you want to add to the object.

## Output Arguments

**propStruct**

Configurable properties of `t`, returned as a structure. The field names of `propStruct` are the property names of `t`, and the associated values of `propStruct` are cell arrays of the possible property values. If the property in `t` does not have a finite set of possible values, the property value in `propStruct` is an empty cell array.

**propCell**

Possible values of a given property name, returned as cell array of strings. If the property does not have a finite set of possible string values, set returns an empty cell array.

## Examples

### Display Configurable Timer Object Properties

Instantiate a timer object and call the `set` method.

```
t = timer;
set(t)
```

```
BusyMode: [{drop} | queue | error]
ErrorFcn: string -or- function handle -or- cell array
ExecutionMode: [{singleShot} | fixedSpacing | fixedDelay | fixedRate
Name
ObjectVisibility: [{on} | off]
Period
StartDelay
StartFcn: string -or- function handle -or- cell array
StopFcn: string -or- function handle -or- cell array
Tag
TasksToExecute
TimerFcn: string -or- function handle -or- cell array
UserData
```

Some of the timer properties, such as `Running`, are not displayed because they are read only.

Use the `set` method to output a structure.

```
out = set(t)
```

```
out =
```

```
 BusyMode: {3x1 cell}
 ErrorFcn: {}
ExecutionMode: {4x1 cell}
 Name: {}
```



```
ObjectVisibility: {2x1 cell}
 Period: {}
 StartDelay: {}
 StartFcn: {}
 StopFcn: {}
 Tag: {}
TasksToExecute: {}
TimerFcn: {}
UserData: {}
```

Delete the timer object from memory.

```
delete(t)
```

### Display Possible Property Values

Instantiate a timer object and display possible values for the `BusyMode` property.

```
t = timer;
set(t, 'BusyMode')
```

```
[{drop} | queue | error]
```

The output shows the three possible values for `BusyMode`. The default value, `drop`, is indicated by curly braces.

Display the possible values for `ErrorFcn`.

```
set(t, 'ErrorFcn')
```

```
string -or- function handle -or- cell array
```

A description of the possible values is displayed since `ErrorFcn` does not have a set list of possible values.

Output the possible property values.

```
out1 = set(t, 'BusyMode')
out2 = set(t, 'ErrorFcn')
```

```
out1 =

 'drop'
 'queue'
 'error'
```

```
out2 =

 {}
```

While `set(t, 'ErrorFcn')` displays a description of the possible values, `out2 = set(t, 'ErrorFcn')` returns an empty cell.

Delete the timer from memory.

```
delete(t)
```

## Set Timer Object Property

Instantiate a timer object and make the object invisible. Display the object's visibility and delete the object.

```
t = timer;
set(t, 'ObjectVisibility', 'off');
get(t, 'ObjectVisibility')
delete(t)
```

```
ans =
```

```
off
```

## Set Timer Object Properties Using Structure

Construct a structure to modify several timer object properties.

```
s.BusyMode = 'queue';
s.ExecutionMode = 'fixedDelay';
s.ObjectVisibility = 'off'
```

```
s =
 BusyMode: 'queue'
 ExecutionMode: 'fixedDelay'
 ObjectVisibility: 'off'
```

Create a timer, display the properties in s, modify the timer, display the new values of the properties, and delete the timer.

```
t = timer;
get(t,{'BusyMode','ExecutionMode','ObjectVisibility'})
set(t,s);
get(t,{'BusyMode','ExecutionMode','ObjectVisibility'})
delete(t)
```

```
ans =
 'drop' 'singleShot' 'on'
```

```
ans =
 'queue' 'fixedDelay' 'off'
```

### Set Timer Objects Using Cell Arrays

Create a cell array of properties to modify, and a cell array of the values of the corresponding properties. Instantiate a timer, and display the initial values of the properties in the property name cell array, nameArr.

```
nameArr = {'BusyMode','ExecutionMode','Period'};
valArr = {'queue','fixedDelay',3};
t = timer;
get(t,nameArr)
```

```
ans =
 'drop' 'singleShot' [1]
```

## timer.set

---

Modify the timer object and display the new property values. Delete the timer.

```
set(t,nameArr,valArr)
get(t,nameArr)
delete(t)

ans =

 'queue' 'fixedDelay' [3]
```

Instantiate an array of three timers. Create a new property name cell array to modify the BusyMode, ExecutionMode, and UserData properties. Display the initial values of the properties for each timer.

```
tArr = [timer timer timer];
nameArr = {'BusyMode','ExecutionMode','UserData'};
get(tArr,nameArr)

ans =

 'drop' 'singleShot' []
 'drop' 'singleShot' []
 'drop' 'singleShot' []
```

Assign each property a different value in each timer. Create a cell array containing the new values. Each row indicates the values for the properties in the corresponding timer.

```
valArr = {'queue','fixedDelay',3;...
 'error','fixedSpacing',42;...
 'drop','fixedRate','hello'};
```

Modify the timer object properties and display the updated values.

```
set(tArr,nameArr,valArr)
get(tArr,nameArr)

ans =
```

```
'queue' 'fixedDelay' [3]
'error' 'fixedSpacing' [42]
'drop' 'fixedRate' 'hello'
```

Delete the timers from memory.

```
delete(tArr)
```

**Alternatives**

You can also use dot notation to set timer object properties. For example, `t.ObjectVisibility = 'off'` sets the property to the same value as `set(t, 'ObjectVisibility', 'off')`.

**See Also**

[timer | get](#)

# timer.start

---

**Purpose** Start timer object

**Syntax** start(t)

**Description** start(t) starts the timer object, t. If t is an array of timer objects, start starts all the timers.

The start method sets the Running property of the timer object to 'on', executes the StartFcn callback, and initiates TimerFcn callback .

**Input Arguments** t  
Object of class timer.

## Examples Start Timer

Create and start a timer that displays the message 'timer started.' as the StartFcn callback and generates a random number as the TimerFcn callback. Delete the timer.

```
t = timer('StartFcn',@(~,~)disp('timer started.'),'TimerFcn',@(~,~)disp(rand))
start(t)
delete(t)
```

```
timer started.
 0.9706
```

Your output from rand will vary.

## Start Several Timers

Create and start three timers that displays a message for the StartFcn callbacks and compute the sine, cosine, and tangent of  $\pi/4$  as the TimerFcn callbacks. Delete the timers.

```
t1 = timer('StartFcn',@(~,~)disp('t1 started.'),'TimerFcn',@(~,~)sin(pi/4))
t2 = timer('StartFcn',@(~,~)disp('t2 started.'),'TimerFcn',@(~,~)cos(pi/4))
t3 = timer('StartFcn',@(~,~)disp('t3 started.'),'TimerFcn',@(~,~)tan(pi/4))
start([t1 t2 t3]);
```

```
delete([t1 t2 t3]);
```

```
t1 started.
t2 started.
t3 started.
```

## See Also

timer | delete | stop | startat

# timer.startat

---

**Purpose** Schedule timer to fire at specified time

**Syntax**  
`startat(t, firingTime)`  
`startat(t, Y, M, D)`  
`startat(t, Y, M, D, H, MI, S)`

**Description** `startat(t, firingTime)` schedules timer, `t`, to fire at specified time, `firingTime`. A timer fires by executing the callback function, `timerFcn`. `firingTime` must be within 25 days of the current time.

- If `t` is an array of timer objects and `firingTime` is a scalar, `startat` sets all the timers to fire at the specified time.
- If `t` is an array of timer objects and `firingTime` is an array of the same size as `t`, `startat` sets each timer to fire at the corresponding time.

`startat(t, Y, M, D)` starts the timer and schedules execution of `TimerFcn` at the year (Y), month (M), and day (D) specified.

`startat(t, Y, M, D, H, MI, S)` also specifies the hour (H), minute (MI), and second (S) specified.

- Algorithms**
- The `startat` method specifies when the timer object executes the `TimerFcn` callback, not when the timer starts running. The timer starts running with the call to the `startat` method.
  - Based on the specified time, `startat` computes and sets the required `StartDelay` property of the timer object, `t`. Additionally, it sets the `Running` property of the timer object to 'on', and executes the `StartFcn` callback.
  - `startat` modifies the timer object's `startDelay` property. As such, `startat` overrides specified values of the timer's `startDelay` property.



**Input Arguments****t**

Object of class `timer`.

**firingTime**

Time at which the timer object is to fire, specified as a serial date number, date string, or a date vector. `firingTime` can be a single date or an array of dates with the same number of rows as timer objects in `t`.

- A serial date number indicates the number of days that have elapsed since 1-Jan-0000 (starting at 1). See `datenum` for additional information about serial date numbers.
- To specify date strings, use the following date formats defined by the `datestr` function: 0, 1, 2, 6, 13, 14, 15, 16, or 23. These numeric identifiers correspond to formats defined by the `formatOut` property of the `datestr` function. Date strings with two-character years are interpreted to be within the 100 years centered on the current year.
- Date vectors are specified as an `m-by-6` or `m-by-3` matrix containing `m` full or partial date vectors, respectively. A full date vector has six elements indicating year, month, day, hour, minute, and second, in that order. A partial date vector has three elements indicating year, month, and day, in that order.

**Y,M,D**

Time at which the timer object is to fire, specified as numbers indicating the year (Y), month (M), and day (D). Month values less than 1 are set to 1; other arguments can wrap and have negative values.

**Y,M,D,H,MI,S**

Time at which the timer object is to fire, specified as numbers indicating the year (Y), month (M), day (D), hour (H), minute (MI), and second (S) specified. Month values less than 1 are set to 1; other arguments can wrap and have negative values.

## Examples

### Start Timer in 2 Seconds

Create a timer that displays messages at start time and firing time.

```
t = timer('TimerFcn', @(~,~)disp('Fired.'), ...
 'StartFcn', @(~,~)disp('Started.'));
```

Set the timer to fire 2 seconds from the present time using a serial date. A serial date is specified in days.

```
two = 2/(60^2*24); % two seconds in serial time
fTime = now + two
startat(t,fTime);
```

```
fTime =

 7.3527e+05
```

```
Started.
Fired.
```

Wait for the timer to fire, and then delete the timer.

```
delete(t)
```

### Start Timer Using Year, Month, Day

Create a timer that displays messages at start time and firing time.

```
t = timer('TimerFcn', @(~,~)disp('Fired.'), ...
 'StartFcn', @(~,~)disp('Started.'));
```

Schedule the timer to start 2 days from present at 00:00:00

```
[Y, M, D, H, MI, S] = datevec(now+2);
startat(t,Y,M,D)
```

```
Started.
```

Manually stop and delete the timer.

stop(t)  
delete(t)

## See Also

timer | delete | start | stop

## Concepts

- “Carryover in Date Vectors and Strings”

# timer.stop

---

**Purpose** Stop timer object

**Syntax** stop(t)

**Description** stop(t) stops the timer object, t. If t is an array of timer objects, the stop method stops each timer.

The stop method sets the Running property of the timer object to 'off' and executes the StopFcn callback .

**Tips**

- Use the stop method to stop a timer manually. The timer automatically stops when the TimerFcn callback executes the number of times specified by the ExecutionMode and TasksToExecute properties or when an error occurs while executing a TimerFcn callback.

**Input Arguments**

**t**  
Object of class timer.

## Examples

### Stop Timer

Create a timer object that generates 100 random numbers and executes one million times. Define a StopFcn callback that displays the message 'Timer has stopped.' Start the timer and verify the timer is running

```
t = timer('TimerFcn','rand(100,1);',...
 'ExecutionMode','fixedSpacing','TasksToExecute',1e6,...
 'StopFcn','disp(''Timer has stopped.'')');
start(t)
t.Running

ans =

on
```

Manually stop the timer and verify it is no longer running. Delete the timer.

```
stop(t)
t.Running
delete(t)
```

```
Timer has stopped.
```

```
ans =
```

```
off
```

## See Also

```
timer | delete | start | startat
```

# timer.timerfind

---

## Purpose

Find timer object

## Syntax

```
out = timerfind
out = timerfind(Name,Value)
out = timerfind(t,Name,Value)
out = timerfind(S)
```

## Description

`out = timerfind` finds the “visible timer objects” on page 1-7130 and returns an array, `out`.

`out = timerfind(Name,Value)` finds “visible timer objects” on page 1-7130 with property values matching those passed as `Name, Value` pair arguments and returns an array, `out`.

`out = timerfind(t,Name,Value)` matches `Name, Value` pair arguments to the timer objects listed in `t`, where `t` can be an array of timer objects, and returns an array, `out`.

`out = timerfind(S)` matches property values defined in the structure, `S`, and returns an array, `out`. The field names of `S` are timer object property names and the field values are the corresponding property values.

## Tips

- `timerfind` only finds “visible timer objects” on page 1-7130. Visible timer objects are those that are in memory and have the `ObjectVisibility` property set to 'on'. To find objects that are hidden, but still valid, use `timerfindall`.

## Input Arguments

**t**

Array of objects of class `timer`

**S**

Structure with field names corresponding to `timer` object property names. Field values are the corresponding property values.

## Name-Value Pair Arguments

Specify optional comma-separated pairs of `Name`, `Value` arguments. `Name` is the argument name and `Value` is the corresponding value. `Name` must appear inside single quotes ( ' '). You can specify several name and value pair arguments in any order as `Name1, Value1, . . . , NameN, ValueN`.

### 'BusyMode'

String that indicates action taken when a timer has to execute `TimerFcn` before the completion of previous execution of the `TimerFcn`. When `Running='on'`, `BusyMode` is read only. This table summarizes the busy modes.

BusyMode Values	Behavior if Queue Empty	Behavior if Queue Not Empty	Notes
'drop'	Adds task to queue	Drops task	Possible skipping of <code>TimerFcn</code>
'error'	Adds task to queue	Completes task; throws error specified by <code>ErrorFcn</code> ; stops timer	Stops timer after completing task in execution queue
'queue'	Adds task to queue	Waits for queue to clear, and then enters task in queue	Adjusts <code>Period</code> property to manage tasks in execution queue

See “Handling Timer Queuing Conflicts” for more information.

**Default:** 'drop'

# timer.timerfind

---

## 'ErrorFcn'

String, function handle, or cell array defining the function that the timer executes when an error occurs. If there is an error, this function executes, and then calls `StopFcn`.

## 'ExecutionMode'

String that defines how the timer object schedules timer events. When `Running='on'`, `ExecutionMode` is read only. This table summarizes the execution modes.

Execution Mode	Time Period Start Point
'singleShot'	In this mode, the timer callback function is only executed once. Therefore, the <code>Period</code> property has no effect. This is the default execution mode.
'fixedRate'	Starts immediately after the timer callback function is added to the MATLAB execution queue
'fixedDelay'	Starts when the timer function callback restarts execution after a time lag due to delays in the MATLAB execution queue
'fixedSpacing'	Starts when the timer callback function finishes executing.

- 'singleShot' is the single execution mode for the timer class, and is the default value.



## singleShot

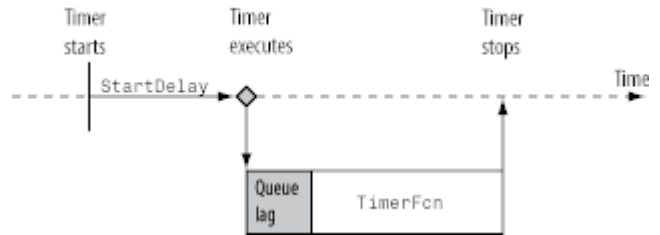

- 'fixedDelay', 'fixedRate', and 'fixedSpacing' are the three supported multiexecution modes. These modes define the starting point of the Period property. The Period property specifies the amount of time between executions, which remains the same. Only the point at which execution begins is different.

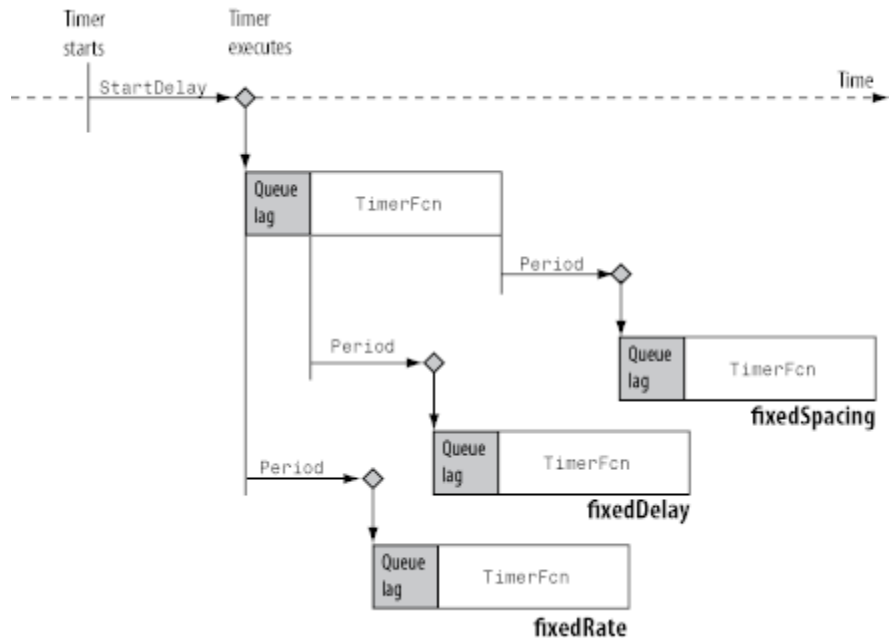

**Default:** 'singleShot'

# timer.timerfind

---

## **'Name'**

String representing the timer name.

**Default:** 'timer-*i*', where *i* is a number indicating the *i*th timer object created this session. To reset *i* to 1, execute the `clear classes` command.

## **'ObjectVisibility'**

String with possible values of 'on' or 'off', that provides a way for you to discourage end-user access to the timer objects your application creates. The `timerfind` function does not return an object whose `ObjectVisibility` property is set to 'off'. Objects that are not visible are still valid. To retrieve a list of all the timer objects in memory, including the invisible ones, use the `timerfindall` function.

**Default:** 'on'

## **'Period'**

Number greater than 0.001 that specifies the delay, in seconds, between executions of `TimerFcn`. For the timer to use `Period`, you must set `ExecutionMode` and `TasksToExecute` to schedule multiple timer object callback events.

**Default:** 1.0

## **'StartDelay'**

Number greater than or equal to 0 that specifies the delay, in seconds, between the start of the timer and the first execution of the function specified in `TimerFcn`. When `Running = 'on'`, `StartDelay` is read only.

**Default:** 0

## **'StartFcn'**

String, function handle, or cell array defining the function that executes when the timer starts.

## **'StopFcn'**

String, function handle, or cell array defining the function that executes when the timer stops. The timer stops when

- You call the timer `stop` method.
- The timer finishes executing `TimerFcn`. In other words, the value of `TasksExecuted` reaches the limit set by `TasksToExecute`.
- An error occurs. The `ErrorFcn` callback is called first, followed by the `StopFcn` callback.

You can use `StopFcn` to define clean up actions, such as deleting the timer object from memory.

## **'Tag'**

String that represents a label for the object.

## **'TasksToExecute'**

Number greater than 0, indicating the number of times the timer object is to execute the `TimerFcn` callback. Use the `TasksToExecute` property to set the number of executions. To use `TasksToExecute`, you must set `ExecutionMode` to schedule multiple timer callback events.

**Default:** `Inf`

## **'TimerFcn'**

String, function handle, or cell array defining the timer callback function. You must define this property before you can start the timer.

## **'UserData'**

# timer.timerfind

---

Generic field for data that you want to add to the object.

## Read Only Name-Value Pair Arguments

### AveragePeriod

Average time in seconds between `TimerFcn` executions since the timer started. Value is NaN until timer executes two timer callbacks.

### InstantPeriod

The time in seconds between the last two executions of `TimerFcn`. Value is NaN until timer executes two timer callbacks.

### Running

String defined as 'off' or 'on', indicating whether the timer is currently executing callback functions.

### TasksExecuted

The number of times the timer called `TimerFcn` since the timer started.

### Type

String that identifies the object type.

## Definitions

### visible timer objects

*Visible timer objects* are timer objects that are in memory and have the `ObjectVisibility` property set to 'on'.

## Examples

### Find Timer Objects Existing in Memory

Create several individual timers and an array of timers.

```
t1 = timer('Tag', 'broadcastProgress','UserData','Monday');
t2 = timer('Tag', 'displayProgress','UserData','Monday');
timerArr = [timer('Tag', 'broadcastProgress','UserData','Tuesday');
 timer('Tag', 'displayProgress','UserData','Tuesday');
 timer('Tag', 'displayProgress','UserData','Wednesday');];
```

Find all the timers in memory.

```
out1 = timerfind
```

Timer Object Array

Index:	ExecutionMode:	Period:	TimerFcn:	Name:
1	singleShot	1	''	timer-1
2	singleShot	1	''	timer-2
3	singleShot	1	''	timer-3
4	singleShot	1	''	timer-4
5	singleShot	1	''	timer-5

Find only those timers in memory that have the string value, 'displayProgress', as the Tag property.

```
out2 = timerfind('Tag','displayProgress')
```

Timer Object Array

Index:	ExecutionMode:	Period:	TimerFcn:	Name:
1	singleShot	1	''	timer-2
2	singleShot	1	''	timer-4
3	singleShot	1	''	timer-5

Limit the search for timers with the string value, 'displayProgress', as the Tag property to timer objects in timerArr.

```
out3 = timerfind(timerArr,'Tag','displayProgress')
```

Timer Object Array

Index:	ExecutionMode:	Period:	TimerFcn:	Name:
1	singleShot	1	''	timer-4
2	singleShot	1	''	timer-5

Define a struct containing the Tag and UserData properties of interest.

# timer.timerfind

---

```
searchStruct = struct('Tag','broadcastProgress','UserData','Monday')

searchStruct =

 Tag: 'broadcastProgress'
 UserData: 'Monday'
```

Use the struct as the search criteria to find timer objects in memory.

```
out4 = timerfind(searchStruct)
```

```
Timer Object: timer-1

Timer Settings
 ExecutionMode: singleShot
 Period: 1
 BusyMode: drop
 Running: off

Callbacks
 TimerFcn: ''
 ErrorFcn: ''
 StartFcn: ''
 StopFcn: ''
```

Delete the timer objects.

```
delete(t1); delete(t2); delete(timerArr)
```

## Delete Timer by Name

Simulate having existing timers in memory by creating an array of timers. Create a new timer with a custom name. List all visible timers.

```
existingTimers = [timer timer timer];

myTimerName = 'myTimer';
anotherTimer = timer('Name',myTimerName);
```

```
timerfind
```

```
Timer Object Array
```

Index:	ExecutionMode:	Period:	TimerFcn:	Name:
1	singleShot	1	''	timer-1
2	singleShot	1	''	timer-2
3	singleShot	1	''	timer-3
4	singleShot	1	''	myTimer

Delete the specified timer and list all visible timers.

```
delete(timerfind('Name',myTimerName));
timerfind
```

```
Timer Object Array
```

Index:	ExecutionMode:	Period:	TimerFcn:	Name:
1	singleShot	1	''	timer-1
2	singleShot	1	''	timer-2
3	singleShot	1	''	timer-3

Delete all visible timers from memory.

```
delete(timerfind)
```

## Find Valid Timer Objects Cleared from Workspace

Use `timerfind` to find 'lost' timer object references. References are lost when you clear the timer object from the workspace, but do not delete it from memory.

Create two timer objects. Since the callback function does not require the timer or event object, you can use the tilde (~) operator to ignore the inputs in the function handle.

```
t1 = timer('TimerFcn',@(~,~)disp('Timer 1 Fired!'));
t2 = timer('TimerFcn',@(~,~)disp('Timer 2 Fired!'));
whos
```

# timer.timerfind

---

Name	Size	Bytes	Class	Attributes
t1	1x1	104	timer	
t2	1x1	104	timer	

Clear one of the timer objects from the workspace. To actually remove the timer from memory, you need to both clear it and delete it.

```
clear t1
whos
```

Name	Size	Bytes	Class	Attributes
t2	1x1	104	timer	

Try to delete the timer, t1.

```
delete(t1)
```

```
Undefined function or variable 't1'.
```

The timer, t1, can not be removed from memory using delete because its reference has been cleared.

Find valid timer objects in memory.

```
out = timerfind
```

```
Timer Object Array
```

Index:	ExecutionMode:	Period:	TimerFcn:	Name:
1	singleShot	1	1x1 function_handle	arraytimer-1
2	singleShot	1	1x1 function_handle	arraytimer-2

Since two timers were found, determine which timer does not exist in the workspace.

```
out ~= t2
```



```
ans =

 1 0
```

The first timer object in `out` is not equal to `t2`. This was previously `t1`. It is reassigned to `t1`. Since it is still valid, the timer can be started.

```
t1 = out(1);
start(t1);
```

```
Timer 1 Fired!
```

Delete timer objects. `timerfind` provides a way of accessing timer objects in memory. It does not copy the objects; therefore you do not need to delete `out` from memory. To verify, use `timerfind`.

```
delete(t1); delete(t2);
timerfind
```

```
ans =

 []
```

## Delete All Timer Objects in Memory

Create four timer objects.

```
t1 = timer('TimerFcn',@(~,~)disp('Timer 1 Fired!'));
t2 = timer('TimerFcn',@(~,~)disp('Timer 2 Fired!'));
t3 = timer('TimerFcn',@(~,~)disp('Timer 3 Fired!'));
t4 = timer('TimerFcn',@(~,~)disp('Timer 4 Fired!'));
```

Clear two timers from the workspace.

```
clear t2 t3
```

Pass `timerfind` to `delete` to remove all timer objects from memory, whether or not they exist in the workspace.

# timer.timerfind

---

```
delete(timerfind)
timerfind
```

```
ans =
```

```
 []
```

## See Also

timer | delete | timerfindall

**Purpose** Find timer object, regardless of visibility

**Syntax**

```
out = timerfindall
out = timerfindall(Name,Value)
out = timerfindall(t,Name,Value)
out = timerfindall(S)
```

**Description** `out = timerfindall` finds timer objects existing in memory, regardless of visibility and returns an array, `out`. Use the `ObjectVisibility` property to set the object's visibility.

`out = timerfindall(Name,Value)` finds timer objects existing in memory, regardless of visibility whose property values match those passed as `Name,Value` pair arguments and returns an array, `out`.

`out = timerfindall(t,Name,Value)` matches `Name,Value` pair arguments to the timer objects listed in `t`, where `t` can be an array of timer objects, and returns an array, `out`.

`out = timerfindall(S)` matches property values defined in the structure, `S` and returns an array, `out`. The field names of `S` are timer object property names and the field values are the corresponding property values.

**Tips**

- `timerfindall` finds timer objects in memory, regardless of the value of the `ObjectVisibility` property. To limit the search to objects with `ObjectVisibility` set to 'on', use `timerfind`.

**Input Arguments**

**t**  
Array of objects of class `timer`.

**S**  
Structure with field names corresponding to timer object property names. Field values are the corresponding property values.

# timer.timerfindall

---

## Name-Value Pair Arguments

Specify optional comma-separated pairs of `Name`, `Value` arguments. `Name` is the argument name and `Value` is the corresponding value. `Name` must appear inside single quotes ( ' '). You can specify several name and value pair arguments in any order as `Name1, Value1, . . . , NameN, ValueN`.

## 'BusyMode'

String that indicates action taken when a timer has to execute `TimerFcn` before the completion of previous execution of the `TimerFcn`. When `Running='on'`, `BusyMode` is read only. This table summarizes the busy modes.

<b>BusyMode Values</b>	<b>Behavior if Queue Empty</b>	<b>Behavior if Queue Not Empty</b>	<b>Notes</b>
'drop'	Adds task to queue	Drops task	Possible skipping of <code>TimerFcn</code>
'error'	Adds task to queue	Completes task; throws error specified by <code>ErrorFcn</code> ; stops timer	Stops timer after completing task in execution queue
'queue'	Adds task to queue	Waits for queue to clear, and then enters task in queue	Adjusts <code>Period</code> property to manage tasks in execution queue

See “Handling Timer Queuing Conflicts” for more information.

**Default:** 'drop'

**'ErrorFcn'**

String, function handle, or cell array defining the function that the timer executes when an error occurs. If there is an error, this function executes, and then calls `StopFcn`.

**'ExecutionMode'**

String that defines how the `timer` object schedules timer events. When `Running='on'`, `ExecutionMode` is read only. This table summarizes the execution modes.

<b>Execution Mode</b>	<b>Time Period Start Point</b>
'singleShot'	In this mode, the timer callback function is only executed once. Therefore, the <code>Period</code> property has no effect. This is the default execution mode.
'fixedRate'	Starts immediately after the timer callback function is added to the MATLAB execution queue
'fixedDelay'	Starts when the timer function callback restarts execution after a time lag due to delays in the MATLAB execution queue
'fixedSpacing'	Starts when the timer callback function finishes executing.

- 'singleShot' is the single execution mode for the timer class, and is the default value.

# timer.timerfindall

## singleShot

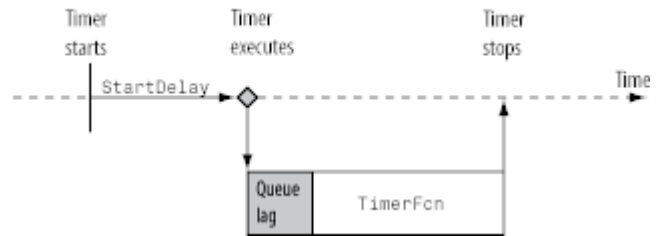

- 'fixedDelay', 'fixedRate', and 'fixedSpacing' are the three supported multiexecution modes. These modes define the starting point of the Period property. The Period property specifies the amount of time between executions, which remains the same. Only the point at which execution begins is different.

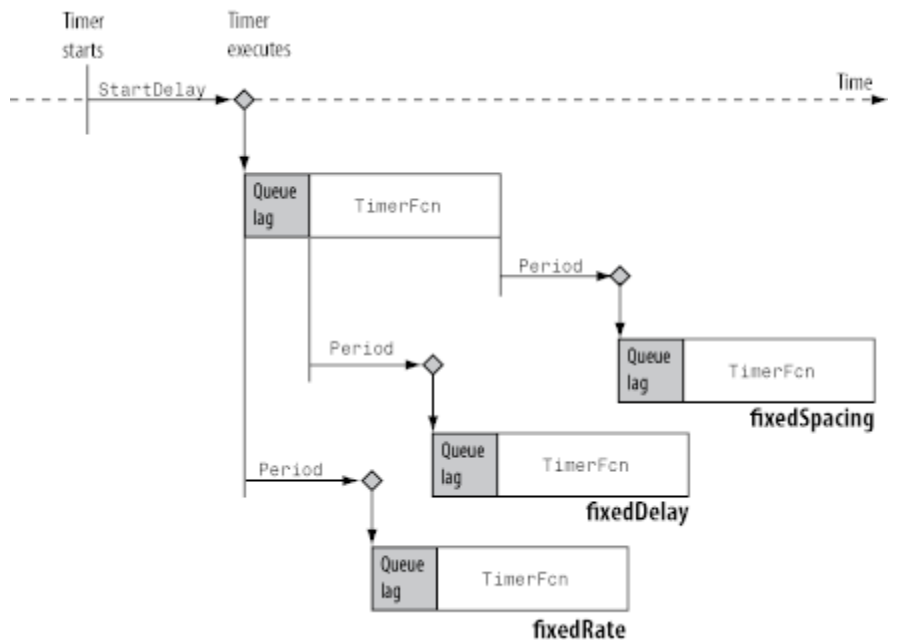

**Default:** 'singleShot'

## **'Name'**

String representing the timer name.

**Default:** 'timer-*i*', where *i* is a number indicating the *i*th timer object created this session. To reset *i* to 1, execute the `clear classes` command.

## **'ObjectVisibility'**

String with possible values of 'on' or 'off', that provides a way for you to discourage end-user access to the timer objects your application creates. The `timerfind` function does not return an object whose `ObjectVisibility` property is set to 'off'. Objects that are not visible are still valid. To retrieve a list of all the timer objects in memory, including the invisible ones, use the `timerfindall` function.

**Default:** 'on'

## **'Period'**

Number greater than 0.001 that specifies the delay, in seconds, between executions of `TimerFcn`. For the timer to use `Period`, you must set `ExecutionMode` and `TasksToExecute` to schedule multiple timer object callback events.

**Default:** 1.0

## **'StartDelay'**

Number greater than or equal to 0 that specifies the delay, in seconds, between the start of the timer and the first execution of the function specified in `TimerFcn`. When `Running = 'on'`, `StartDelay` is read only.

**Default:** 0

## **'StartFcn'**

# timer.timerfindall

---

String, function handle, or cell array defining the function that executes when the timer starts.

## **'StopFcn'**

String, function handle, or cell array defining the function that executes when the timer stops. The timer stops when

- You call the timer stop method.
- The timer finishes executing `TimerFcn`. In other words, the value of `TasksExecuted` reaches the limit set by `TasksToExecute`.
- An error occurs. The `ErrorFcn` callback is called first, followed by the `StopFcn` callback.

You can use `StopFcn` to define clean up actions, such as deleting the timer object from memory.

## **'Tag'**

String that represents a label for the object.

## **'TasksToExecute'**

Number greater than 0, indicating the number of times the timer object is to execute the `TimerFcn` callback. Use the `TasksToExecute` property to set the number of executions. To use `TasksToExecute`, you must set `ExecutionMode` to schedule multiple timer callback events.

**Default:** `Inf`

## **'TimerFcn'**

String, function handle, or cell array defining the timer callback function. You must define this property before you can start the timer.

## **'UserData'**



Generic field for data that you want to add to the object.

## Read Only Name-Value Pair Arguments

### AveragePeriod

Average time in seconds between TimerFcn executions since the timer started. Value is NaN until timer executes two timer callbacks.

### InstantPeriod

The time in seconds between the last two executions of TimerFcn. Value is NaN until timer executes two timer callbacks.

### Running

String defined as 'off' or 'on', indicating whether the timer is currently executing callback functions.

### TasksExecuted

The number of times the timer called TimerFcn since the timer started.

### Type

String that identifies the object type.

## Examples

### Find and Delete All Timers From Memory

Create four timer objects.

```
t1 = timer('TimerFcn',@(~,~)disp('Timer 1 Fired!'));
t2 = timer('TimerFcn',@(~,~)disp('Timer 2 Fired!'));
t3 = timer('TimerFcn',@(~,~)disp('Timer 3 Fired!'));
t4 = timer('TimerFcn',@(~,~)disp('Timer 4 Fired!'));
```

Set timers t2 and t4 to be invisible.

```
t2.ObjectVisibility = 'off';
t4.ObjectVisibility = 'off';
```

# timer.timerfindall

---

Clear timers t1 and t2 from the workspace.

```
clear t1 t2
whos
```

Name	Size	Bytes	Class	Attributes
t3	1x1	104	timer	
t4	1x1	104	timer	

Find all visible timers in memory.

```
timerfind
```

Timer Object Array

Index:	ExecutionMode:	Period:	TimerFcn:	Name:
1	singleShot	1	1x1 function_handle	arraytimer-1
2	singleShot	1	1x1 function_handle	arraytimer-3

timerfind finds only timers t1 and t2, since they are visible. Timer t2 is still valid and in memory even though it was cleared from the workspace

Find all timers in memory.

```
timerfindall
```

Timer Object Array

Index:	ExecutionMode:	Period:	TimerFcn:	Name:
1	singleShot	1	1x1 function_handle	arraytimer-1
2	singleShot	1	1x1 function_handle	arraytimer-2
3	singleShot	1	1x1 function_handle	arraytimer-3
4	singleShot	1	1x1 function_handle	arraytimer-4

timerfindall finds all four valid timers in memory even though t2 and t4 are invisible and t1 and t2 were cleared from the workspace.

Delete all timers from memory.

```
delete(timerfindall)
```

## Find Timer Objects Existing in Memory

Create several individual timers and an array of timers.

```
t1 = timer('Tag', 'broadcastProgress', 'UserData', 'Monday');
t2 = timer('Tag', 'displayProgress', 'UserData', 'Monday');
timerArr = [timer('Tag', 'broadcastProgress', 'UserData', 'Tuesday');
 timer('Tag', 'displayProgress', 'UserData', 'Tuesday');
 timer('Tag', 'displayProgress', 'UserData', 'Wednesday')];
```

Make timer t1 and timerArr(2) invisible.

```
t1.ObjectVisibility = 'off';
timerArr(2).ObjectVisibility = 'off';
```

Find all the timers in memory using timerfind.

```
out1 = timerfind
```

Timer Object Array

Index:	ExecutionMode:	Period:	TimerFcn:	Name:
1	singleShot	1	''	timer-2
2	singleShot	1	''	timer-3
3	singleShot	1	''	timer-5

timerfind does not find the hidden timers.

Find all the timers in memory using timerfindall.

```
out2 = timerfindall
```

Timer Object Array

Index:	ExecutionMode:	Period:	TimerFcn:	Name:
1	singleShot	1	''	timer-1

# timer.timerfindall

---

```
2 singleShot 1 '' timer-2
3 singleShot 1 '' timer-3
4 singleShot 1 '' timer-4
5 singleShot 1 '' timer-5
```

timerfindall finds all timers, even the invisible ones.

Find only those timers in memory that have the string value, 'displayProgress', as the Tag property.

```
out3 = timerfindall('Tag','displayProgress')
```

Timer Object Array

```
Index: ExecutionMode: Period: TimerFcn: Name:
1 singleShot 1 '' timer-2
2 singleShot 1 '' timer-4
3 singleShot 1 '' timer-5
```

Limit the search for timers that have the string value, 'displayProgress', as the Tag property to timer objects in timerArr.

```
out4 = timerfindall(timerArr,'Tag','displayProgress')
```

Timer Object Array

```
Index: ExecutionMode: Period: TimerFcn: Name:
1 singleShot 1 '' timer-4
2 singleShot 1 '' timer-5
```

Define a struct containing the Tag and UserData properties of interest.

```
searchStruct = struct('Tag','broadcastProgress','UserData','Monday')
```

```
searchStruct =
```

```
Tag: 'broadcastProgress'
UserData: 'Monday'
```

Use the struct as the search criteria to find timer objects in memory.

```
out5 = timerfindall(searchStruct)
```

```
Timer Object: timer-1
```

```
Timer Settings
```

```
 ExecutionMode: singleShot
```

```
 Period: 1
```

```
 BusyMode: drop
```

```
 Running: off
```

```
Callbacks
```

```
 TimerFcn: ''
```

```
 ErrorFcn: ''
```

```
 StartFcn: ''
```

```
 StopFcn: ''
```

Delete the timer objects.

```
delete(timerfindall)
```

## Find Invisible Timers

Create four timer objects.

```
t1 = timer('TimerFcn',@(~,~)disp('Timer 1 Fired!'));
```

```
t2 = timer('TimerFcn',@(~,~)disp('Timer 2 Fired!'));
```

```
t3 = timer('TimerFcn',@(~,~)disp('Timer 3 Fired!'));
```

```
t4 = timer('TimerFcn',@(~,~)disp('Timer 4 Fired!'));
```

Set timers t2 and t4 to be invisible, and clear timers t1 and t2 from the workspace.

```
t2.ObjectVisibility = 'off';
```

```
t4.ObjectVisibility = 'off';
```

```
clear t1 t2;
```

```
whos
```

# timer.timerfindall

---

Name	Size	Bytes	Class	Attributes
t3	1x1	104	timer	
t4	1x1	104	timer	

Find all valid invisible timers.

```
out = timerfindall('ObjectVisibility','off')
```

Timer Object Array

Index:	ExecutionMode:	Period:	TimerFcn:	Name:
1	singleShot	1	1x1 function_handle array	timer-2
2	singleShot	1	1x1 function_handle array	timer-4

Both valid invisible timers were found by `timerfindall`, regardless of whether they were in the workspace.

## See Also

`timer` | `delete` | `timerfind`

<b>Purpose</b>	Block command prompt until timer stops running
<b>Syntax</b>	<code>wait(t)</code>
<b>Description</b>	<p><code>wait(t)</code> blocks the command prompt until timer, <code>t</code>, stops running. If <code>t</code> is an array of timer objects, <code>wait</code> blocks the MATLAB command line until each timer in <code>t</code> has stopped running.</p> <p>To block the command line, the timer object must first start via <code>start</code> or <code>startat</code> before calling the <code>wait</code> method. If the timer is not running, <code>wait</code> returns immediately.</p>
<b>Input Arguments</b>	<p><b>t</b></p> <p>Array of timer objects</p>

## Examples

### Block Command Prompt While Timer Runs

Create a timer that waits 10 seconds, and then displays a message. Start the timer and wait for it to finish.

```
T = timer('TimerFcn',@(~,~)disp('Fired.'), 'StartDelay',10);
start(T);
```

```
Fired.
```

Notice that after the timer starts, the MATLAB prompt returns.

Start the timer and use the `wait` method to block anyone from entering commands at the MATLAB command line. You must start the timer before calling the `wait` command.

```
start(T);
wait(T);
```

```
Fired.
```

Notice that after the timer starts, the MATLAB prompt disappears until the timer stops.

# timer.wait

---

Delete the timer.

```
delete(T)
```

## See Also

[timer | start](#)



<b>Purpose</b>	Element-wise multiplication
<b>Syntax</b>	<code>C = A.*B</code> <code>C = times(A,B)</code>
<b>Description</b>	<p><code>C = A.*B</code> multiplies arrays A and B element by element and returns the result in C.</p> <p><code>C = times(A,B)</code> is an alternate way to execute <code>A.*B</code>, but is rarely used. It enables operator overloading for classes.</p>
<b>Input Arguments</b>	<p><b>A - Left array</b> scalar   vector   matrix   multidimensional array</p> <p>Left array, specified as a scalar, vector, matrix, or multidimensional array. Inputs A and B must be the same size unless one is a scalar. A scalar value expands into an array of the same size as the other input.</p> <p><b>Data Types</b> single   double   int8   int16   int32   int64   uint8   uint16   uint32   uint64   logical   char <b>Complex Number Support:</b> Yes</p> <p><b>B - Right array</b> scalar   vector   matrix   multidimensional array</p> <p>Right array, specified as a scalar, vector, matrix, or multidimensional array. Inputs A and B must be the same size unless one is a scalar. A scalar value expands into an array of the same size as the other input.</p> <p><b>Data Types</b> single   double   int8   int16   int32   int64   uint8   uint16   uint32   uint64   logical   char <b>Complex Number Support:</b> Yes</p>
<b>Examples</b>	<p><b>Multiply Two Vectors</b></p> <p>Create two vectors, A and B, and multiply them element by element.</p>

## times, .\*

---

```
A = [1 0 3];
B = [2 3 7];
C = A.*B
```

```
C =

 2 0 21
```

### Multiply Two Arrays

Create two 3-by-3 arrays, A and B, and multiply them element by element.

```
A = [1 0 3; 5 3 8; 2 4 6];
B = [2 3 7; 9 1 5; 8 8 3];
C = A.*B
```

```
C =

 2 0 21
 45 3 40
 16 32 18
```

### See Also

[mtimes](#)

**Purpose**

Add title to current axes

**Syntax**

```
title(str)
title(str,Name,Value)

title(axes_handle, ___)

h = title(___)
```

**Description**

`title(str)` adds the title consisting of a string, `str`, at the top and in the center of the current axes. Each axes graphics object has one predefined title.

`title(str,Name,Value)` additionally specifies the title properties using one or more `Name,Value` pair arguments.

`title(axes_handle, ___ )` adds the title to the axes specified by `axes_handle`. This syntax allows you to specify the axes to which to add a title. `axes_handle` can precede any of the input argument combinations in the previous syntaxes.

`h = title( ___ )` returns the handle to the text object used as the title. The handle is useful when making future modifications to the title.

**Input Arguments****str - Text to display as title**

string

Text to display as a title, specified as a string. You also can specify the name of a function that returns a string.

**Example:** 'myTitle'

**Example:** date

---

**Note** The words `default`, `factory`, and `remove` are reserved words that will not appear in a title when quoted as a normal string. To display any of these words individually, type `'\reserved_word'` instead of `'reserved_word'`.

---

## **axes\_handle - Axes handle**

`handle`

Axes handle, which is the reference to an axes object. Use the `gca` function to get the handle to the current axes, for example, `axes_handle = gca;`

## **Name-Value Pair Arguments**

Specify optional comma-separated pairs of `Name`, `Value` arguments. `Name` is the argument name and `Value` is the corresponding value. `Name` must appear inside single quotes (`' '`). You can specify several name and value pair arguments in any order as `Name1,Value1,...,NameN,ValueN`.

**Example:** `'Color','red','FontSize',14` adds a title with red, 14-point font.

In addition to the following, you can specify other text object properties using `Name`, `Value` pair arguments. See [Text Properties](#).

## **'Color' - Text color**

`[0 0 0]` (black) (default) | 3-element RGB vector | string

Text color, specified as the comma-separated pair consisting of `'Color'` and a 3-element RGB vector or a string containing the short or long name of the color. The RGB vector is a 3-element row vector whose elements specify the intensities of the red, green, and blue components of the color. The intensities must be in the range `[0 1]`.

The following table lists the predefined colors and their RGB equivalents.

RGB Value	Short Name	Long Name
[1 1 0]	y	yellow
[1 0 1]	m	magenta
[0 1 1]	c	cyan
[1 0 0]	r	red
[0 1 0]	g	green
[0 0 1]	b	blue
[1 1 1]	w	white
[0 0 0]	k	black

**Example:** 'Color',[0 1 0]

**Example:** 'Color','green'

### **'FontAngle' - Character slant**

'normal' (default) | 'italic' | 'oblique'

Character slant, specified as the comma-separated pair consisting of 'FontAngle' and one of these values: 'normal', 'italic', or 'oblique'. MATLAB uses the FontAngle property to select a font from those available on your particular system. Generally, setting this property to italic or oblique selects a slanted font.

**Example:** 'FontAngle','italic'

### **'FontName' - Font name**

'Helvetica' (default) | string | 'FixedWidth'

Font name, specified as the comma-separated pair consisting of 'FontName' and a string. The string specifies the name of the font to use for the text object. To display and print properly, this must be a font that your system supports.

To use a fixed-width font that looks good in any locale, use the case-sensitive string 'FixedWidth'. This eliminates the need to

hard-code the name of a fixed-width font, which might not display text properly on systems that do not use ASCII character encoding.

**Example:** 'FontName', 'Courier'

## **'FontSize' - Font size**

10 points (default) | scalar

Font size, specified as the comma-separated pair consisting of 'FontSize' and a scalar in units determined by the FontUnits property. The default value for FontUnits is points.

**Example:** 'FontSize', 12.5

## **'FontUnits' - Font size units**

'points' (default) | 'normalized' | 'inches' | 'centimeters' | 'pixels'

Font size units, specified as the comma-separated pair consisting of 'FontUnits' and one of the following strings:

- 'points'
- 'normalized'
- 'inches'
- 'centimeters'
- 'pixels'

When the value of FontUnits is 'normalized', MATLAB interprets the value of FontSize as a fraction of the height of the parent axes. When you resize the axes, MATLAB modifies the screen FontSize accordingly. points, inches, centimeters, and pixels are absolute units. 1 point =  $\frac{1}{72}$  inch

---

**Note** When setting both the `FontSize` and the `FontUnits`, you must set the `FontUnits` property first so that MATLAB can correctly interpret the specified `FontSize`. For example, to set the font size to 0.3 inches, call `'FontUnits','inches','FontSize',0.3` in the argument list.

---

### **'FontWeight' - Weight of text characters**

`'normal'` (default) | `'bold'` | `'light'` | `'demi'`

Weight of text characters, specified as the comma-separated pair consisting of `'FontWeight'` and one of the following strings:

- `'normal'`
- `'bold'`
- `'light'`
- `'demi'`

MATLAB uses the `FontWeight` property to select a font from those available on your particular system. Generally, setting this property to `'bold'` or `'demi'` causes MATLAB to use a bold font.

**Example:** `'FontWeight','bold'`

### **'Interpreter' - Character interpretation**

`'tex'` (default) | `'latex'` | `'none'`

Character interpretation, specified as the comma-separated pair consisting of `'Interpreter'` and one of the following strings.

# title

---

Interpreter value	Result
'tex'	Supports a subset of plain TeX markup language. See the <code>String</code> property for a list of supported TeX instructions.
'latex'	Supports a basic subset of the LaTeX markup language.
'none'	Interprets all characters as literal characters.

**Example:** `'Interpreter', 'latex'`

## Output Arguments

### **h** - Handle to text object

scalar

Handle to the text object, returned as a scalar. This is a unique identifier, which you can use to query and modify the properties of the title.

## Examples

### **Add Title to Current Figure**

Create a figure and display a title in the current axes.

```
figure
plot((1:10).^2)
title('My Title')
```



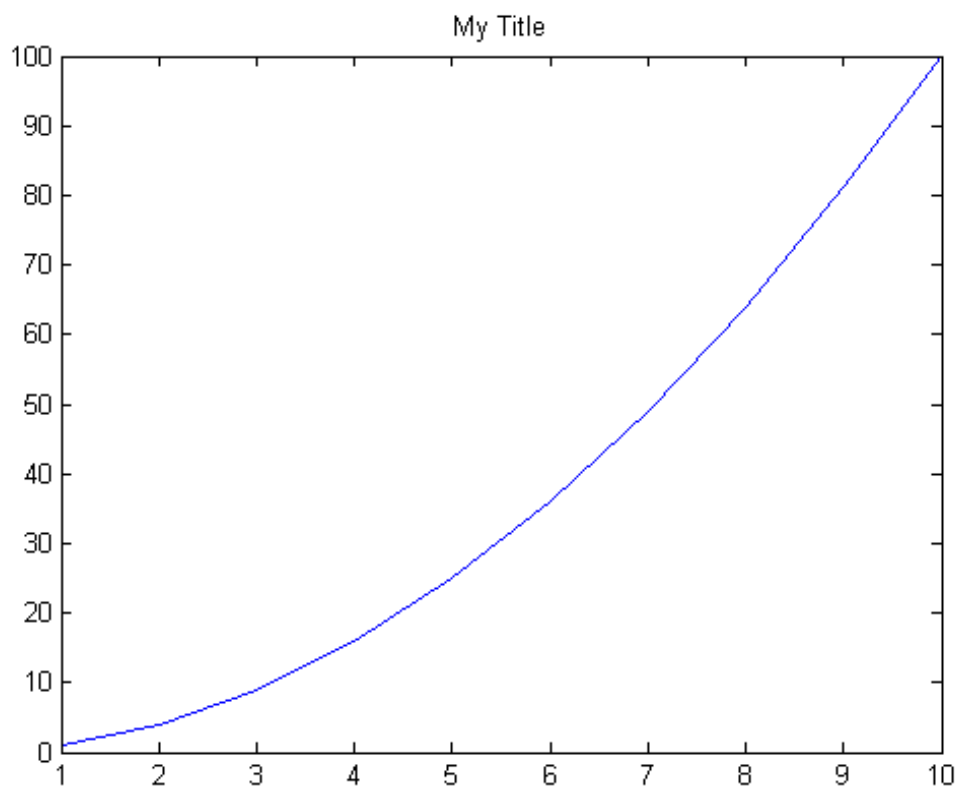

You also can call `title` with a function that returns a string. For example, the `date` function returns a string containing today's date.

```
title(date)
```

# title

---

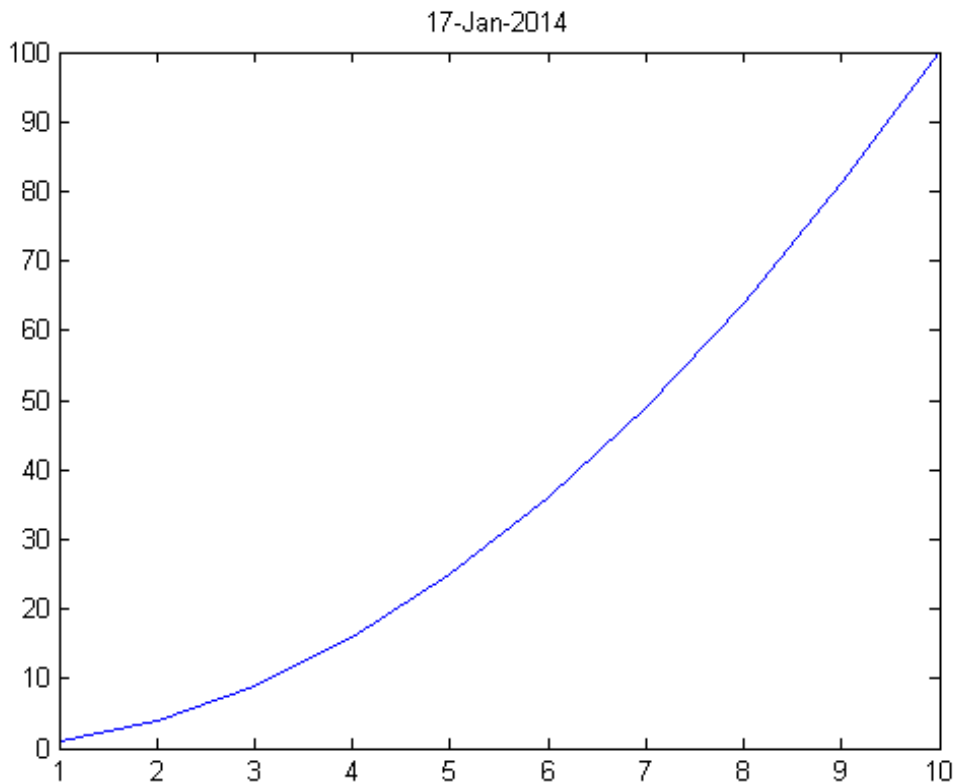

MATLAB® sets the output of `date` as the axes title.

## Include Variable's Value in Title

Include the value of variable `c` in a title.

```
figure
plot((1:10).^2)
f = 70;
c = (f-32)/1.8;
title(['Temperature is ', num2str(c), ' C'])
```

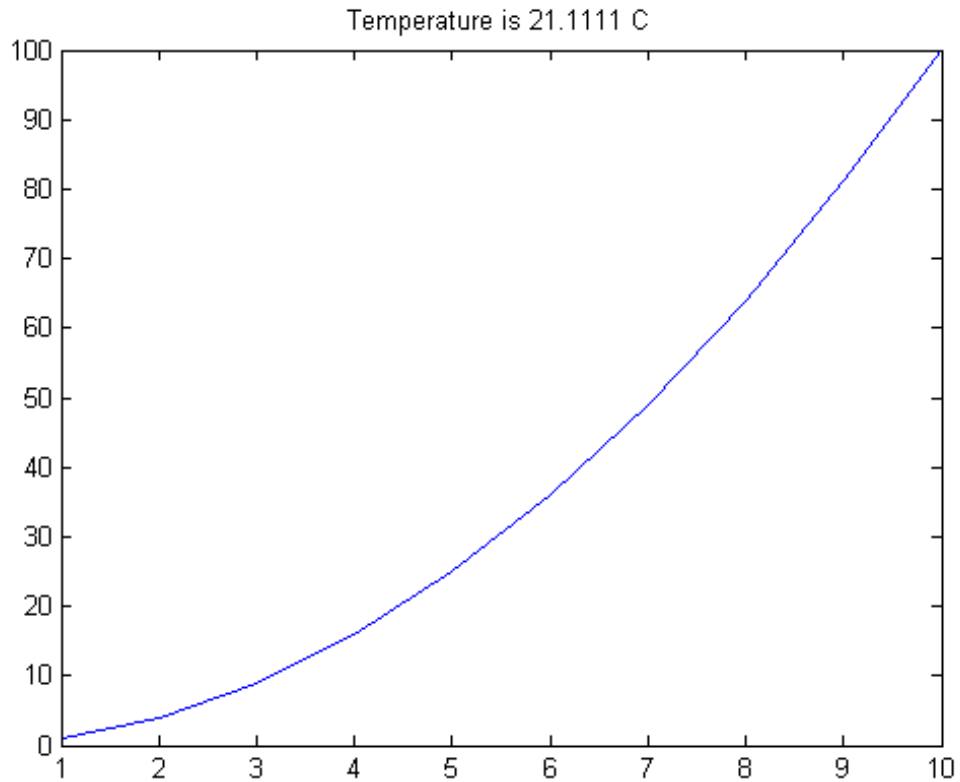

### Create Multicolored Title Using TeX Markup

In a TeX string, use the color modifier `\color` to change the color of characters following it from the previous color.

```
figure
plot((1:10).^2)
title(['\fontsize{16}black {\color{magenta}magenta '...
'\color[rgb]{0.5.5}teal \color{red}red} black again'])
```

# title

---

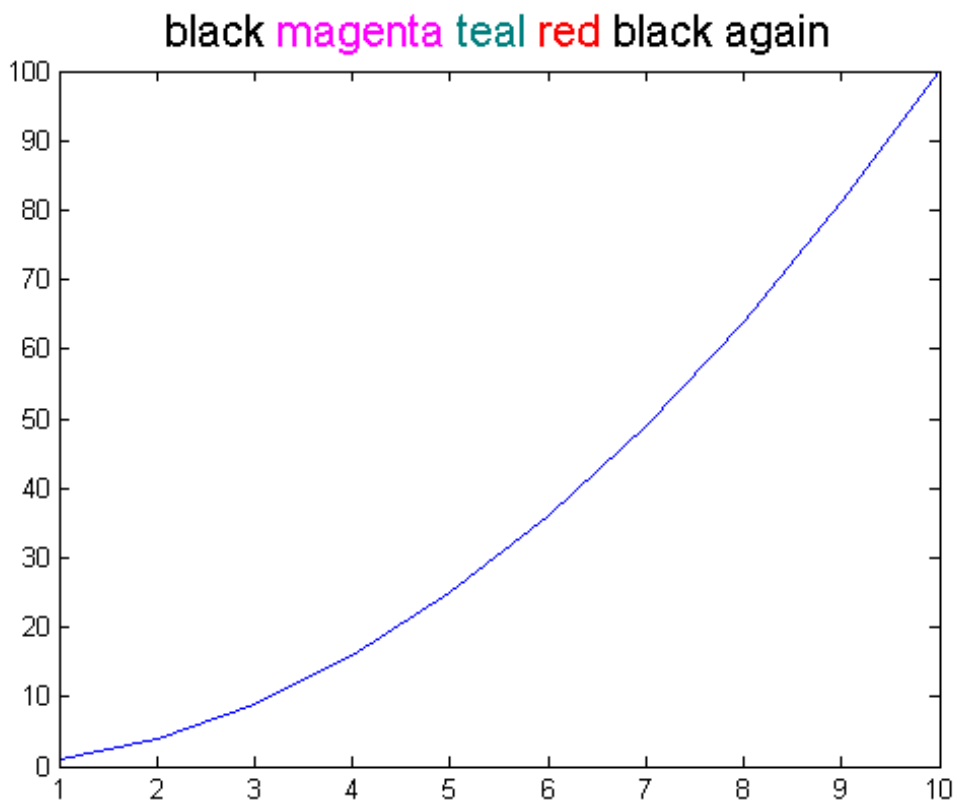

## Create Colored Title Using Name,Value Pair Argument

Use the Name,Value pair 'Color', 'm' to set the color of the title to magenta.

```
figure
plot((1:10).^2)
title('Case number # 3','Color', 'm')
```

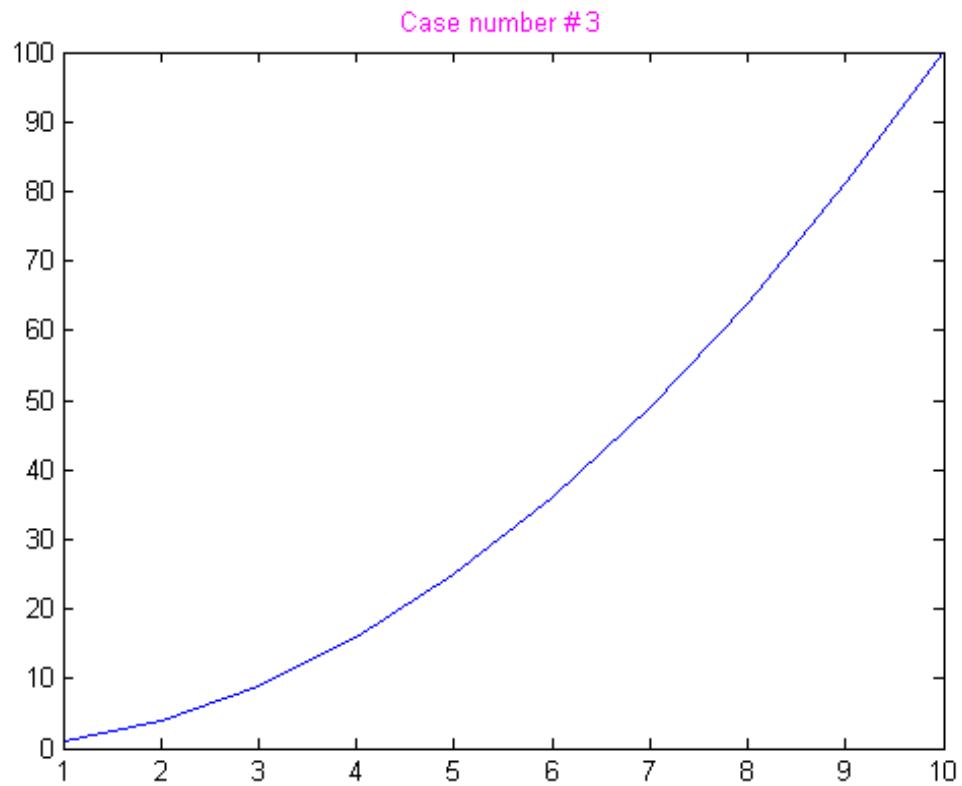

### Include Greek Symbols in Title

Use a TeX string to include Greek symbols in a title.

```
t = (0:0.01:0.2);
y = exp(-25*t);
figure
plot(t,y)
title('y = \ite^{\lambda t}','Color','b')
```

# title

---

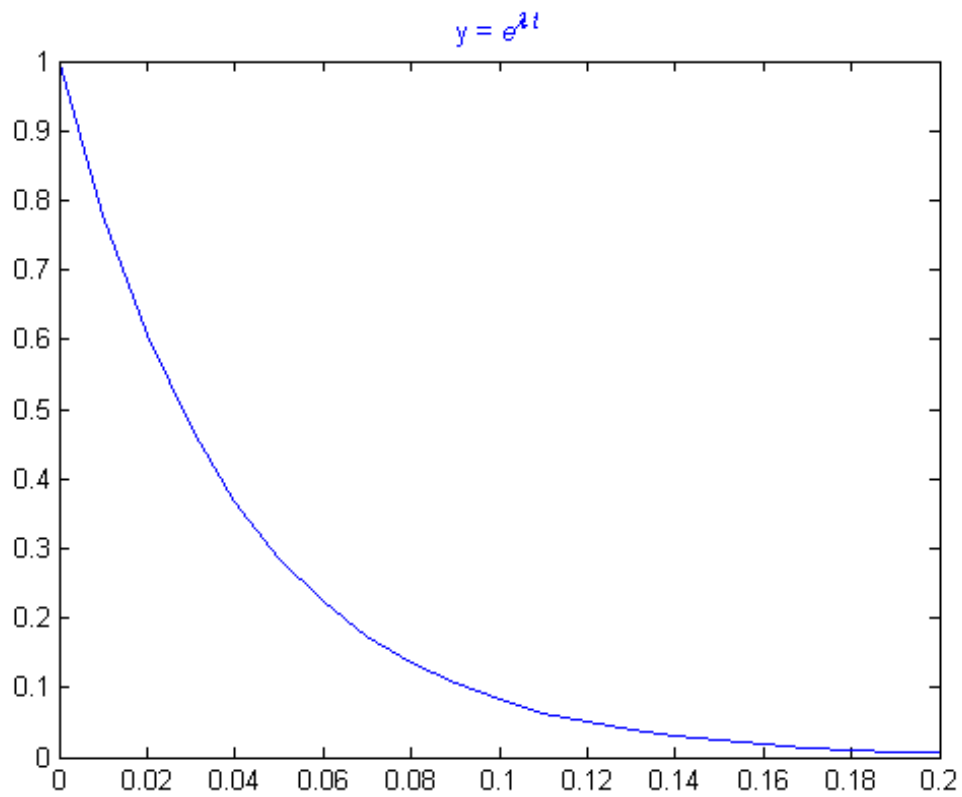

The 'Interpreter' property must be 'tex' (the default).

## **Include Superscript or Subscript Character in Title**

```
figure
plot((1:10).^2)
title('\alpha^2 and X_1')
```

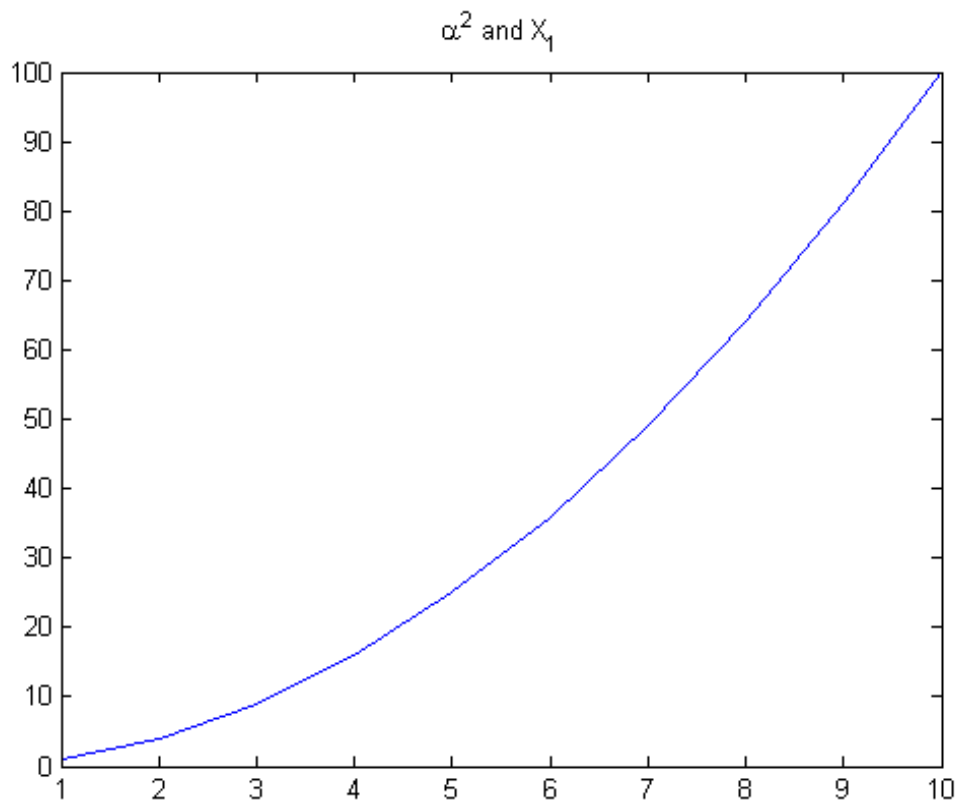

The superscript character, "^", and the subscript character, "\_", modify the character or substring defined in braces immediately following.

### Create Multiline Title

Create a multiline title using a multiline cell array.

```
figure
plot((1:10).^2)
title({'First line'; 'Second line'})
```

# title

---

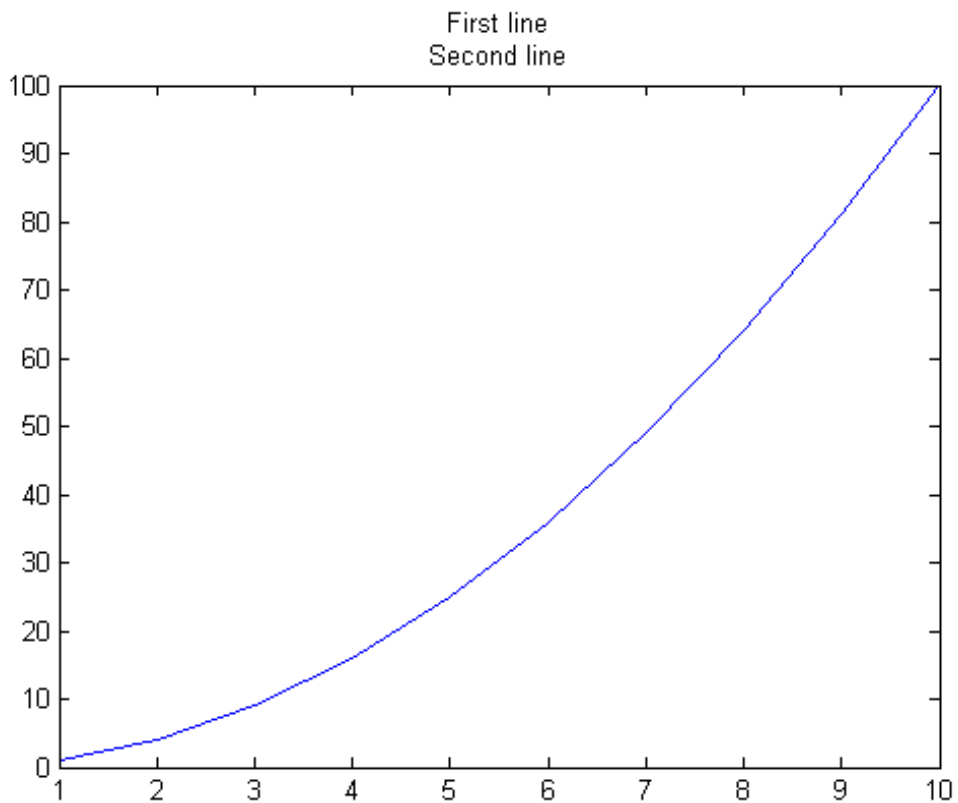

## Display Text As Typed

Set the Interpreter property as 'none' so that the string `X_1` is displayed in the figure as typed, without making 1 a subscript of X.

```
figure
plot((1:10).^2)
title('X_1','Interpreter','none')
```



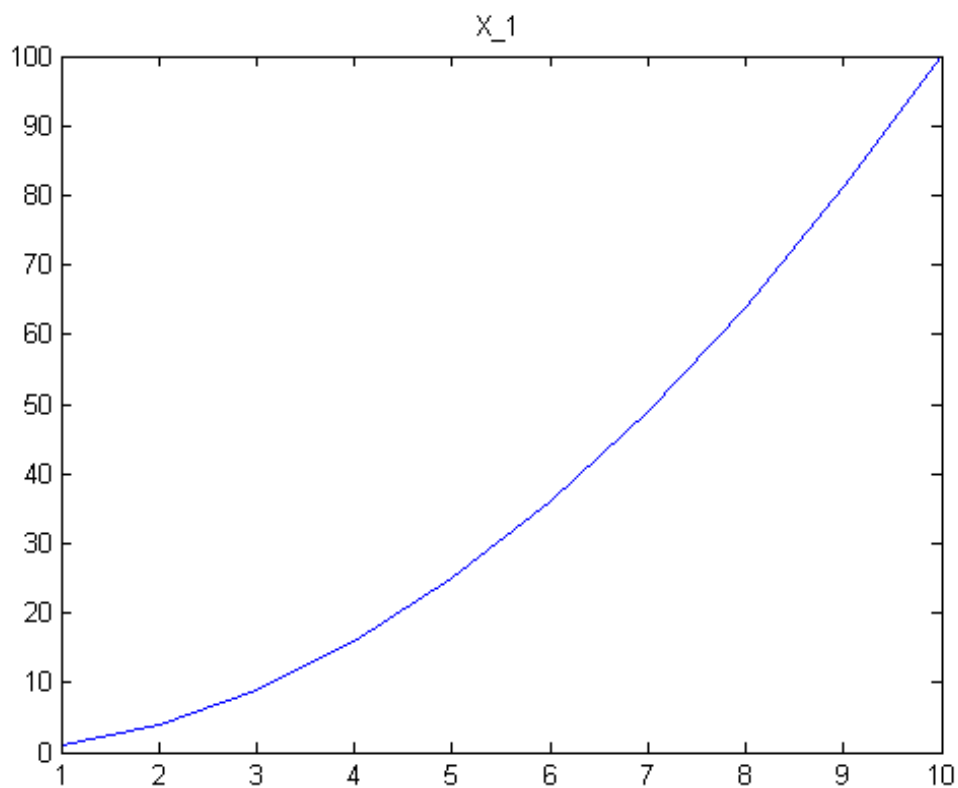

MATLAB® displays the string  $X_1$  in the title of the figure.

### Add Title to Specific Axes

Create two subplots and return the handles to the axes objects,  $s(1)$  and  $s(2)$ .

```
figure
s(1) = subplot(2,1,1);
plot((1:10).^2)
```

# title

---

```
s(2) = subplot(2,1,2);
plot((1:10).^3)
```

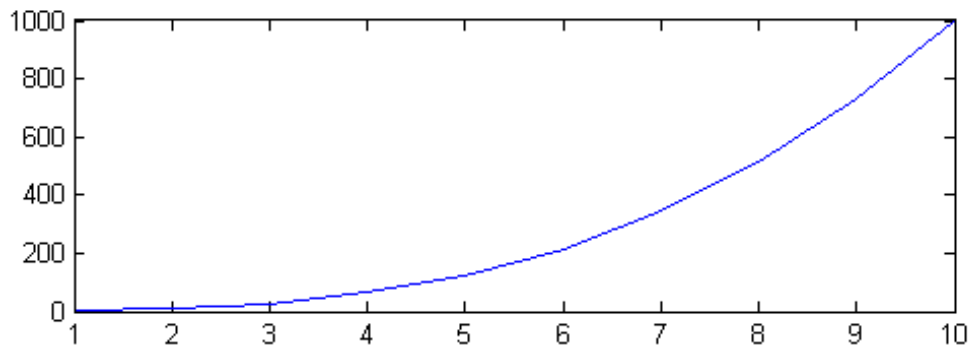
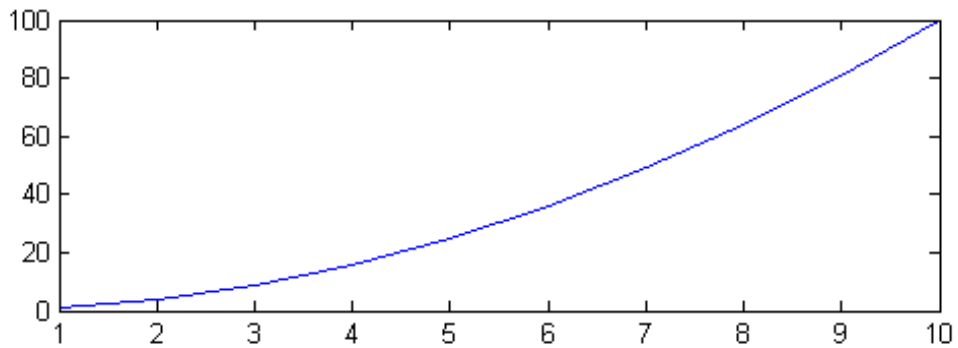

Add a title to each subplot by referring to its axes handle, `s(1)`, or `s(2)`.

```
title(s(1), 'Top Plot')
title(s(2), 'Bottom Plot')
```

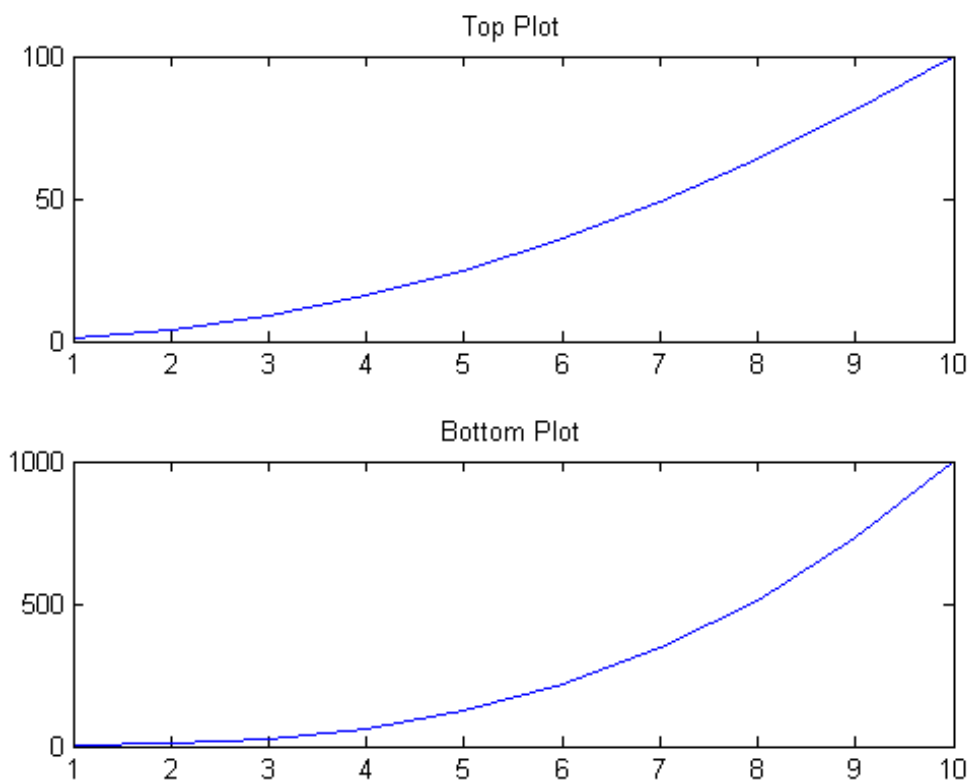

### Add Title and Return Text Handle

Add a title to a plot and return the handle to the text object used as the title.

```
figure
plot((1:10).^2)
h = title('My Title');
```

# title

---

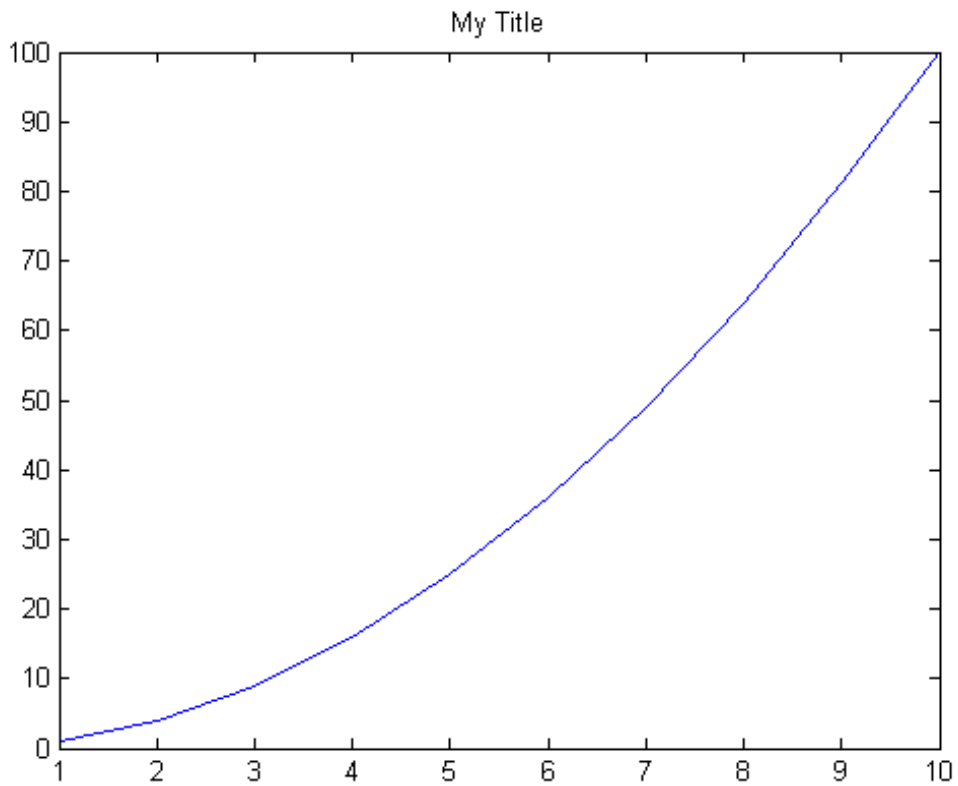

MATLAB® returns the handle in the output variable, `h`.

Set the color of the title to red, using the handle.

```
set(h, 'Color', 'red')
```

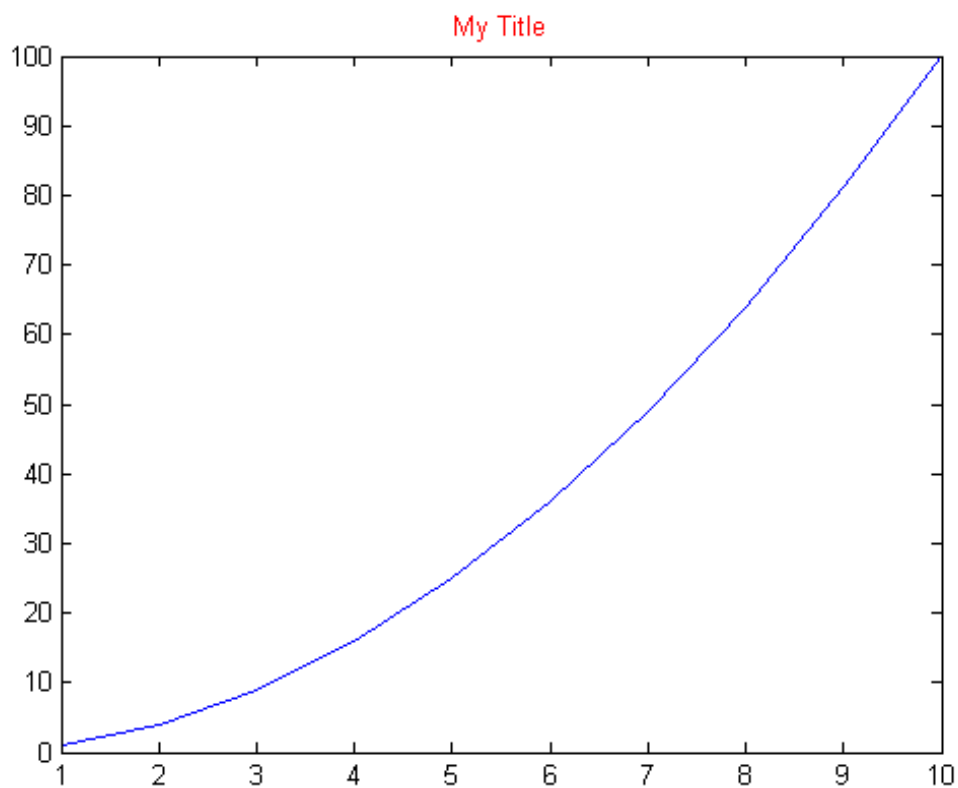
**See Also**

`gtext` | `int2str` | `num2str` | `text` | `xlabel` | `ylabel` | `zlabel` | `gca`

**Concepts**

- Adding Titles to Graphs
- Text Properties

# todatenum

---

**Purpose** Convert CDF epoch object to MATLAB datenum

**Syntax** `n = todatenum(obj)`

**Description** `n = todatenum(obj)` converts the CDF epoch object `ep_obj` into a MATLAB serial date number. Note that a CDF epoch is the number of milliseconds since 01-Jan-0000 whereas a MATLAB datenum is the number of days since 00-Jan-0000.

**Examples** Construct a CDF epoch object from a date string, and then convert the object back into a MATLAB date string:

```
dstr = datestr(today)
dstr =
 08-Oct-2003

obj = cdfepoch(dstr)
obj =
 cdfepoch object:
 08-Oct-2003 00:00:00

dstr2 = datestr(todatenum(obj))
dstr2 =
 08-Oct-2003
```

**See Also** `cdfepoch` | `cdfinfo` | `cdfread` | `datenum`

**Purpose** Toeplitz matrix

**Syntax** `T = toeplitz(c,r)`  
`T = toeplitz(r)`

**Description** A *Toeplitz* matrix is defined by one row and one column. A *symmetric Toeplitz* matrix is defined by just one row. `toeplitz` generates Toeplitz matrices given just the row or row and column description.

`T = toeplitz(c,r)` returns a nonsymmetric Toeplitz matrix `T` having `c` as its first column and `r` as its first row. If the first elements of `c` and `r` are different, a message is printed and the column element is used.

For a real vector `r`, `T = toeplitz(r)` returns the symmetric Toeplitz matrix formed from vector `r`, where `r` defines the first row of the matrix. For a complex vector `r` with a real first element, `T = toeplitz(r)` returns the Hermitian Toeplitz matrix formed from `r`, where `r` defines the first row of the matrix and `r'` defines the first column. When the first element of `r` is not real, the resulting matrix is Hermitian off the main diagonal, i.e.,  $T_{ij} = \text{conj}(T_{ji})$  for  $i \neq j$ .

**Examples** A Toeplitz matrix with diagonal disagreement is

```
c = [1 2 3 4 5];
r = [1.5 2.5 3.5 4.5 5.5];
toeplitz(c,r)
Column wins diagonal conflict:
ans =
 1.000 2.500 3.500 4.500 5.500
 2.000 1.000 2.500 3.500 4.500
 3.000 2.000 1.000 2.500 3.500
 4.000 3.000 2.000 1.000 2.500
 5.000 4.000 3.000 2.000 1.000
```

**See Also** `hankel` | `kron`

# toolboxdir

---

**Purpose** Root folder for specified toolbox

**Syntax**

```
toolboxdir('tbxFolderName')
s = toolboxdir('tbxFolderName')
s = toolboxdir tbxFolderName
```

**Description** `toolboxdir('tbxFolderName')` returns a string that is the absolute path to the specified toolbox, `tbxFolderName`, where `tbxFolderName` is the folder name for the toolbox.

`s = toolboxdir('tbxFolderName')` returns the absolute path to the specified toolbox to the output argument, `s`.

`s = toolboxdir tbxFolderName` is the command form of the syntax.

**Tips** `toolboxdir` is particularly useful for MATLAB Compiler software. The base folder of all toolboxes installed with MATLAB software is:

```
matlabroot/toolbox/tbxFolderName
```

However, in deployed mode, the base folders of the toolboxes are different. `toolboxdir` returns the correct root folder, whether running from MATLAB or from an application deployed with the MATLAB Compiler software.

To determine the folder name for a given toolbox, run the following code, substituting the name of a product function for *toolboxfcn*:

```
n = 'toolboxfcn';
pat = '(?<=^.+[\\\/]toolbox[\\\/])[^\\\/]+';
regexp(which(n), pat, 'match', 'once')
```

For example, to determine the product name for Control System Toolbox set `n` to the name of a function unique to Control System Toolbox, such as `dss`:

```
n = 'dss'
pat = '(?<=^.+[\\\/]toolbox[\\\/])[^\\\/]+'
regexp(which(n), pat, 'match', 'once')
```



control

## Examples

Obtain the path for the Control System Toolbox software:

```
s = toolboxdir('control')
```

MATLAB returns:

```
s = C:\Program Files\MATLAB\R2012a\toolbox\control
```

## See Also

[fullfile](#) | [matlabroot](#) | [path](#)

# trace

---

<b>Purpose</b>	Sum of diagonal elements
<b>Syntax</b>	<code>b = trace(A)</code>
<b>Description</b>	<code>b = trace(A)</code> is the sum of the diagonal elements of the matrix A.
<b>Algorithms</b>	<code>t = sum(diag(A));</code>
<b>See Also</b>	<code>det</code>   <code>eig</code>

<b>Purpose</b>	Transpose
<b>Syntax</b>	<code>b = a.'</code> <code>b = transpose(a)</code>
<b>Description</b>	<code>b = a.'</code> computes the non-conjugate transpose of matrix <code>a</code> and returns the result in <code>b</code> . <code>b = transpose(a)</code> is called for the syntax <code>a.'</code> when <code>a</code> is an object.
<b>See Also</b>	<code>ctranspose</code>   <code>permute</code>

# trapez

---

**Purpose** Trapezoidal numerical integration

**Syntax**  
`Q = trapz(Y)`  
`Q = trapz(X,Y)`  
`Q = trapz( __ ,dim)`

**Description** `Q = trapz(Y)` returns the approximate integral of `Y` via the trapezoidal method with unit spacing. The size of `Y` determines the dimension to integrate along:

- If `Y` is a vector, then `trapz(Y)` is the approximate integral of `Y`.
- If `Y` is a matrix, then `trapz(Y)` integrates over each column and returns a row vector of integration values.
- If `Y` is a multidimensional array, then `trapz(Y)` integrates over the first dimension whose size does not equal 1. The size of this dimension becomes 1, and the sizes of other dimensions remain unchanged.

`Q = trapz(X,Y)` integrates `Y` with spacing increment `X`. By default, `trapz` operates on the first dimension of `Y` whose size does not equal 1. `length(X)` must be equal to the size of this dimension. If `X` is a scalar, then `trapz(X,Y)` is equivalent to `X*trapz(Y)`.

`Q = trapz( __ ,dim)` integrates along the dimension `dim` using any of the previous syntaxes. You must specify `Y`, and optionally can specify `X`. The length of `X`, if specified, must be the same as `size(Y,dim)`. For example, if `Y` is a matrix, then `trapz(X,Y,2)` integrates each row of `Y`.

## **Input Arguments**

**Y - Numeric data**  
vector | matrix | multidimensional array

Numeric data, specified as a vector, matrix, or multidimensional array. By default, `trapz` integrates along the first dimension of `Y` whose size does not equal 1.

**Data Types**

single | double

**Complex Number Support:** Yes

**X - Point spacing**

1 (default) | uniform scalar spacing | vector of nonuniform spacings

Point spacing, specified as 1 (default), a uniform scalar spacing, or a vector of nonuniform spacings. If X is a vector, then `length(X)` must be the same as the size of the integration dimension in Y.

**Data Types**

single | double

**Complex Number Support:** Yes

**dim - Dimension to operate along**

positive integer scalar

Dimension to operate along, specified as a positive integer scalar. If no value is specified, the default is the first array dimension whose size does not equal 1.

Consider a two-dimensional input array, Y:

- `trapz(Y,1)` works on successive elements in the columns of Y and returns a row vector of integration values.

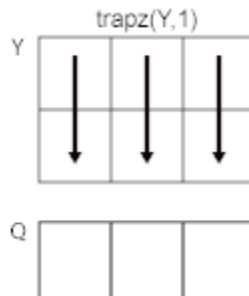

- `trapz(Y,2)` works on successive elements in the rows of Y and returns a column vector of integration values.

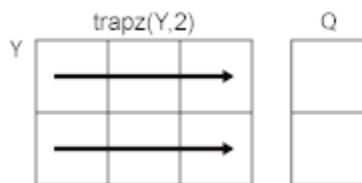

If `dim` is greater than `ndims(Y)`, then `trapz` returns an array of zeros of the same size as `Y`.

## Examples

### Integrate Vector of Data with Unit Spacing

Create a numeric vector of data.

```
Y = [1 4 9 16 25];
```

`Y` contains five evenly spaced points from the function  $f(x) = x^2$ .

Use `trapz` to integrate the data points with unit spacing.

```
Q = trapz(Y)
```

```
Q =
```

```
42
```

This approximate integration yields a value of 42. In this case, the

exact answer is a little less,  $41\frac{1}{3}$ . The `trapz` function overestimates the value of the integral because  $f(x)$  is concave up.

### Integrate Vector of Data with Nonunit Spacing

Create a domain vector, `X`.

```
X = 0:pi/100:pi;
```

Calculate the sine of `X` and store the result in `Y`.

```
Y = sin(X);
```

Integrate the function values contained in Y using trapz.

```
Q = trapz(X,Y)
```

```
Q =
```

```
1.9998
```

When the spacing between points is constant, but not equal to 1, you can multiply by the spacing value, in this case  $\pi/100 \cdot \text{trapz}(Y)$ . The answer is the same if you pass the value directly to the function with `trapz(X,Y)`.

### Integrate Matrix with Nonuniform Spacing

Create a vector of time values, X. Also create a matrix, Y, containing values evaluated at the irregular intervals in X.

```
X = [1 2.5 7 10]';
```

```
Y = [5.2 4.8 4.9 5.1; 7.7 7.0 6.5 6.8; 9.6 10.5 10.5 9.0; 13.2 14.5 15.2 15.2];
```

```
Y =
```

```
5.2000 4.8000 4.9000 5.1000
7.7000 7.0000 6.5000 6.8000
9.6000 10.5000 10.5000 9.0000
13.2000 14.5000 13.8000 15.2000
```

The columns of Y represent velocity data, taken at the times contained in X, for several different trials.

Use trapz to integrate each column independently and find the total distance traveled in each trial. Since the function values are not evaluated at constant intervals, specify X to indicate the spacing between the data points.

```
Q = trapz(X,Y)
```

```
Q =

 82.8000 85.7250 83.2500 80.7750
```

The result is a row vector of integration values, one for each column in  $Y$ . By default, `trapz` integrates along the first dimension of  $Y$  whose size does not equal 1.

Alternatively, you can integrate the rows of a matrix by specifying `dim = 2`.

In this case, use `trapz` on  $Y'$ , which contains the velocity data in the rows.

```
dim = 2;
Q1 = trapz(X,Y',dim)
```

```
Q1 =

 82.8000
 85.7250
 83.2500
 80.7750
```

The result is a column vector of integration values, one for each row in  $Y'$ .

## Multiple Numerical Integrations

Created a grid of domain values.

```
x = -3:.1:3;
y = -5:.1:5;
[X,Y] = meshgrid(x,y);
```

Calculate the function  $f(x,y) = x^2 + y^2$  over the grid.

```
F = X.^2 + Y.^2;
```



trapz integrates numeric data rather than functional expressions, so in general the expression does not need to be known to use trapz on a matrix of data.

Use trapz to approximate the double integral

$$I = \int_{-5}^5 \int_{-3}^3 (x^2 + y^2) dx dy .$$

To perform double or triple integrations on an array of numeric data, nest function calls to trapz.

$$I = \text{trapz}(y, \text{trapz}(x, F, 2))$$

$$I =$$

$$680.2000$$

trapz performs the integration over  $x$  first, producing a column vector. Then, the integration over  $y$  reduces the column vector to a single scalar. trapz slightly overestimates the exact answer of 680 because  $f(x,y)$  is concave up.

## Definitions

### Trapezoidal Method

trapz performs numerical integration via the trapezoidal method. This method approximates the integration over an interval by breaking the area down into trapezoids with more easily computable areas.

For an integration with  $N+1$  evenly spaced points, the approximation is

$$\begin{aligned} \int_a^b f(x) dx &\approx \frac{b-a}{2N} \sum_{n=1}^N (f(x_n) + f(x_{n+1})) \\ &= \frac{b-a}{2N} [f(x_1) + 2f(x_2) + \dots + 2f(x_N) + f(x_{N+1})], \end{aligned}$$

# trapz

---

where the spacing between each point is equal to the scalar value  $\frac{b-a}{N}$ .

If the spacing between the points is not constant, then the formula generalizes to

$$\int_a^b f(x) dx \approx \frac{1}{2} \sum_{n=1}^N (x_{n+1} - x_n) [f(x_n) + f(x_{n+1})],$$

where  $(x_{n+1} - x_n)$  is the spacing between each consecutive pair of points.

## Tips

- `trapz` reduces the size of the dimension it operates on to 1, and returns only the final integration value. `cumtrapz` also returns the intermediate integration values, preserving the size of the dimension it operates on.

## See Also

`cumsum` | `cumtrapz` | `integral` | `integral2` | `integral3`

## Concepts

- “Integration of Numeric Data”

**Purpose** Lay out tree or forest

**Syntax** `[x,y] = treelayout(parent,post)`  
`[x,y,h,s] = treelayout(parent,post)`

**Description** `[x,y] = treelayout(parent,post)` lays out a tree or a forest. `parent` is the vector of parent pointers, with 0 for a root. `post` is an optional postorder permutation on the tree nodes. If you omit `post`, `treelayout` computes it. `x` and `y` are vectors of coordinates in the unit square at which to lay out the nodes of the tree to make a nice picture.

`[x,y,h,s] = treelayout(parent,post)` also returns the height of the tree `h` and the number of vertices `s` in the top-level separator.

**See Also** `etree` | `treepplot` | `etreeplot` | `symbfact`

# treeplot

**Purpose** Plot picture of tree

**Syntax** `treeplot(p)`  
`treeplot(p,nodeSpec,edgeSpec)`

**Description** `treeplot(p)` plots a picture of a tree given a vector of parent pointers, with  $p(i) = 0$  for a root.

`treeplot(p,nodeSpec,edgeSpec)` allows optional parameters `nodeSpec` and `edgeSpec` to set the node or edge color, marker, and linestyle. Use `' '` to omit one or both.

**Examples** To plot a tree with 12 nodes, call `treeplot` with a 12-element input vector. The index of each element in the vector is shown adjacent to each node in the figure below. (These indices are shown only for the point of illustrating the example; they are not part of the `treeplot` output.)

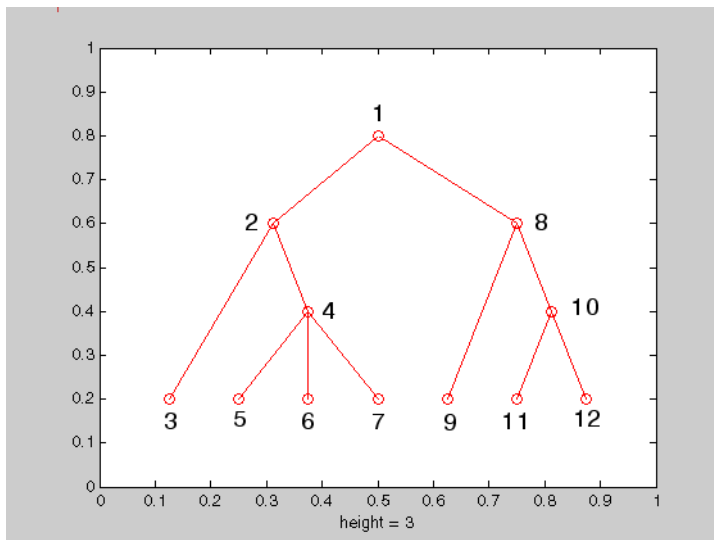

To generate this plot, set the value of each element in the nodes vector to the index of its parent, (setting the parent of the root node to zero).

The node marked 1 in the figure is represented by `nodes(1)` in the input vector, and because this is the root node which has a parent of zero, you set its value to zero:

```
nodes(1) = 0; % Root node
```

`nodes(2)` and `nodes(8)` are children of `nodes(1)`, so set these elements of the input vector to 1:

```
nodes(2) = 1; nodes(8) = 1;
```

`nodes(5:7)` are children of `nodes(4)`, so set these elements to 4:

```
nodes(5) = 4; nodes(6) = 4; nodes(7) = 4;
```

Continue in this manner until each element of the vector identifies its parent. For the plot shown above, the `nodes` vector now looks like this:

```
nodes = [0 1 2 2 4 4 4 1 8 8 10 10];
```

Now call `treeplot` to generate the plot:

```
treeplot(nodes)
```

## See Also

`etree` | `etreeplot` | `treelayout`

# tril

**Purpose** Lower triangular part of matrix

**Syntax**  
`L = tril(X)`  
`L = tril(X,k)`

**Description** `L = tril(X)` returns the lower triangular part of `X`.  
`L = tril(X,k)` returns the elements on and below the `k`th diagonal of `X`. `k = 0` is the main diagonal, `k > 0` is above the main diagonal, and `k < 0` is below the main diagonal.

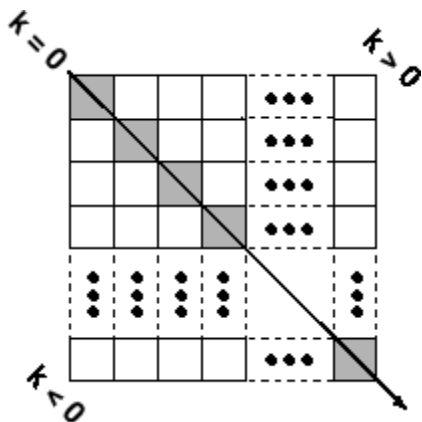

**Examples** `tril(ones(4,4), -1)`

`ans =`

```
0 0 0 0
1 0 0 0
1 1 0 0
1 1 1 0
```

**See Also** `diag` | `triu`

**Purpose**

Triangular mesh plot

**Syntax**

```
trimesh(Tri,X,Y,Z,C)
trimesh(Tri,X,Y,Z)
trimesh(Tri,X,Y)
trimesh(TR)
trimesh(... 'PropertyName',PropertyValue...)
h = trimesh(...)
```

**Description**

`trimesh(Tri,X,Y,Z,C)` displays triangles defined in the  $m$ -by-3 face matrix `Tri` as a mesh. Each row of `Tri` defines a single triangular face by indexing into the vectors or matrices that contain the X, Y, and Z vertices. The edge color is defined by the vector `C`.

`trimesh(Tri,X,Y,Z)` uses `C = Z` so color is proportional to surface height.

`trimesh(Tri,X,Y)` displays the triangles in a 2-D plot.

`trimesh(TR)` displays the triangles in a triangulation representation.

`trimesh(... 'PropertyName',PropertyValue...)` specifies additional patch property names and values for the patch graphics object created by the function.

`h = trimesh(...)` returns a handle to the displayed triangles.

**Examples****Create Triangular Mesh Plot**

Create vertex vectors and a face matrix, and then create a triangular mesh plot.

```
[x,y]=meshgrid(1:15,1:15);
tri = delaunay(x,y);
z = peaks(15);
trimesh(tri,x,y,z)
```

# trimesh

---

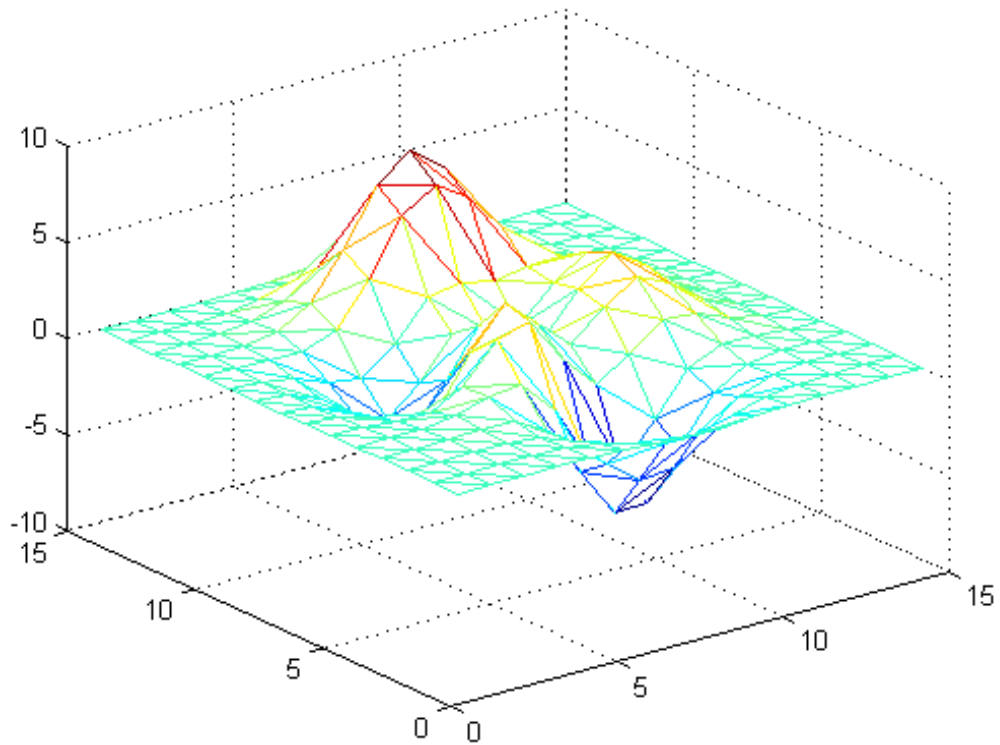

If the surface is already a triangulation representation, then you can pass the triangulation to `trimesh`:

```
tr = triangulation(tri,x(:),y(:),z(:));
trimesh(tr)
```

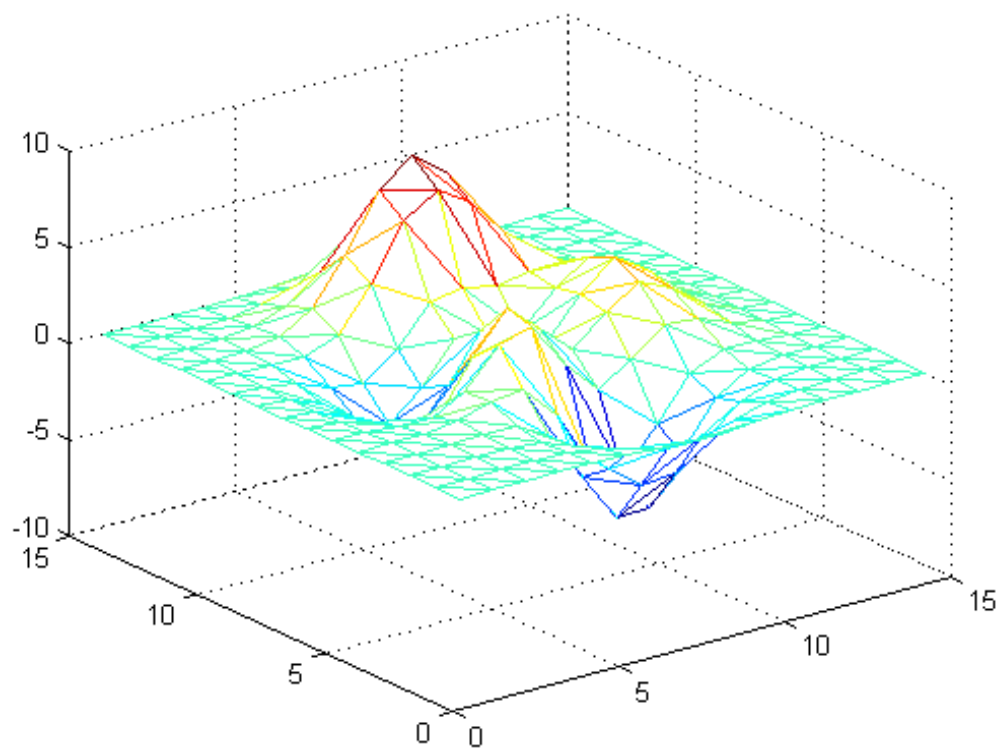

**See Also**

`patch` | `trisurf` | `delaunay` | `delaunayTriangulation` | `triangulation`

# triplequad

---

## Purpose

Numerically evaluate triple integral

`triplequad` will be removed in a future release. Use `integral3` instead.

## Syntax

```
q = triplequad(fun,xmin,xmax,ymin,ymax,zmin,zmax)
q = triplequad(fun,xmin,xmax,ymin,ymax,zmin,zmax,tol)
q = triplequad(fun,xmin,xmax,ymin,ymax,zmin,zmax,tol,method)
```

## Description

`q = triplequad(fun,xmin,xmax,ymin,ymax,zmin,zmax)` evaluates the triple integral  $\text{fun}(x,y,z)$  over the three dimensional rectangular region  $x_{\min} \leq x \leq x_{\max}$ ,  $y_{\min} \leq y \leq y_{\max}$ ,  $z_{\min} \leq z \leq z_{\max}$ . The first input, `fun`, is a function handle. `fun(x,y,z)` must accept a vector `x` and scalars `y` and `z`, and return a vector of values of the integrand.

“Parameterizing Functions” explains how to provide additional parameters to the function `fun`, if necessary.

`q = triplequad(fun,xmin,xmax,ymin,ymax,zmin,zmax,tol)` uses a tolerance `tol` instead of the default, which is  $1.0e-6$ .

`q = triplequad(fun,xmin,xmax,ymin,ymax,zmin,zmax,tol,method)` uses the quadrature function specified as `method`, instead of the default `quad`. Valid values for `method` are `@quadl` or the function handle of a user-defined quadrature method that has the same calling sequence as `quad` and `quadl`.

## Examples

Pass function handle `@integrnd` to `triplequad`:P

```
Q = triplequad(@integrnd,0,pi,0,1,-1,1);
```

where the file `integrnd.m` is

```
function f = integrnd(x,y,z)
f = y*sin(x)+z*cos(x);
```

Pass anonymous function handle `F` to `triplequad`:

```
F = @(x,y,z)y*sin(x)+z*cos(x);
Q = triplequad(F,0,pi,0,1,-1,1);
```

This example integrates  $y\sin(x)+z\cos(x)$  over the region  $0 \leq x \leq \pi$ ,  $0 \leq y \leq 1$ ,  $-1 \leq z \leq 1$ . Note that the integrand can be evaluated with a vector  $x$  and scalars  $y$  and  $z$ .

## See Also

[dblquad](#) | [quad2d](#) | [quad](#) | [quadgk](#) | [quadl](#) | [function\\_handle](#) | [integral](#) | [integral2](#) | [integral3](#)

## How To

- “Anonymous Functions”

# triplot

---

**Purpose** 2-D triangular plot

**Syntax**

```
triplot(TRI,x,y)
triplot(TRI,x,y,color)
triplot(TR)
h = triplot(...)
triplot(...,'param','value','param','value'...)
```

**Description** `triplot(TRI,x,y)` displays the triangles defined in the m-by-3 matrix TRI. A row of TRI contains indices into the vectors x and y that define a single triangle. The default line color is blue.

`triplot(TRI,x,y,color)` uses the string color as the line color. color can also be a line specification. See `ColorSpec` for a list of valid color strings. See `LineStyle` for information about line specifications.

`triplot(TR)` displays the triangles in a triangulation representation.

`h = triplot(...)` returns a vector of handles to the displayed triangles.

`triplot(...,'param','value','param','value'...)` allows additional line property name/property value pairs to be used when creating the plot. See `Line Properties` for information about the available properties.

## **Examples** **Plot Delaunay Triangulation**

Plot a Delaunay triangulation for 10 randomly generated points.

```
P = gallery('uniformdata',10,2,2);
DT = delaunayTriangulation(P);
triplot(DT)
```

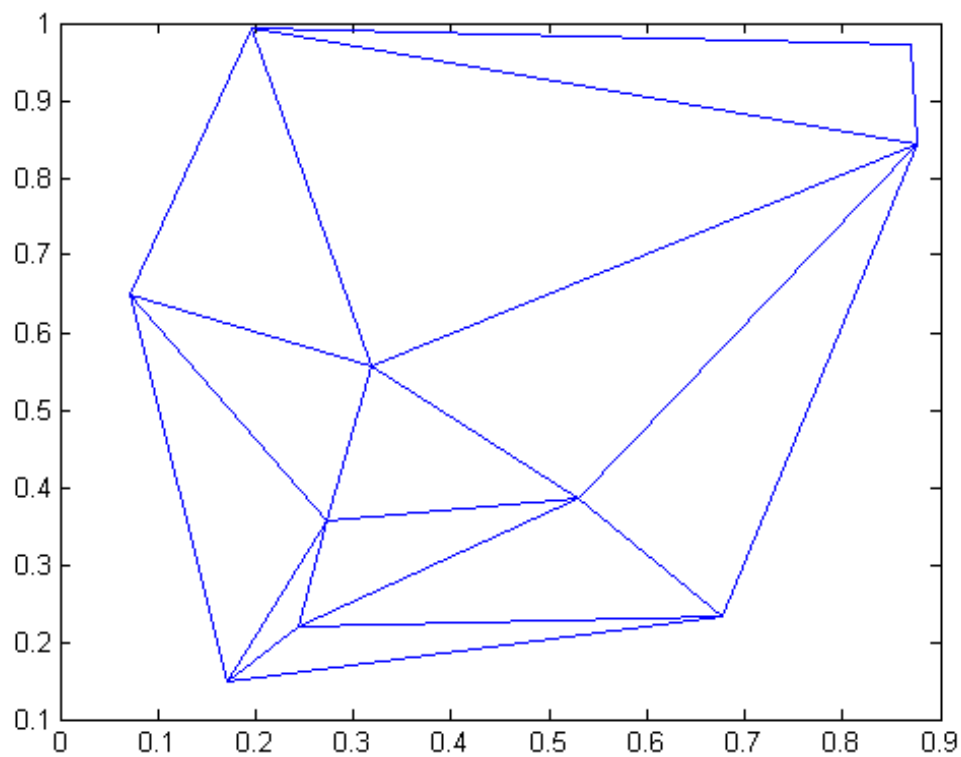
**See Also**

[delaunayTriangulation](#) | [triangulation](#) | [delaunay](#) | [trimesh](#)  
| [trisurf](#)

# TriRep

---

**Purpose** (Will be removed) Triangulation representation

---

**Note** TriRep will be removed in a future release. Use `triangulation` instead.

---

**Description** TriRep provides topological and geometric queries for triangulations in 2-D and 3-D space. For example, for triangular meshes you can query triangles attached to a vertex, triangles that share an edge, neighbor information, circumcenters, or other features. You can create a `TriRep` directly using existing triangulation data. Alternatively, you can create a Delaunay triangulation, via `DelaunayTri`, which provides access to the `TriRep` functionality.

**Construction** `TriRep` (Will be removed) Triangulation representation

**Methods**

<code>baryToCart</code>	(Will be removed) Convert point coordinates from barycentric to Cartesian
<code>cartToBary</code>	(Will be removed) Convert point coordinates from cartesian to barycentric
<code>circumcenters</code>	(Will be removed) Circumcenters of specified simplices
<code>edgeAttachments</code>	(Will be removed) Simplices attached to specified edges
<code>edges</code>	(Will be removed) Triangulation edges

faceNormals	(Will be removed) Unit normals to specified triangles
featureEdges	(Will be removed) Sharp edges of surface triangulation
freeBoundary	(Will be removed) Facets referenced by only one simplex
incenters	(Will be removed) Incenters of specified simplices
isEdge	(Will be removed) Test if vertices are joined by edge
neighbors	(Will be removed) Simplex neighbor information
size	(Will be removed) Size of triangulation matrix
vertexAttachments	(Will be removed) Return simplices attached to specified vertices

**Properties**

X	Coordinates of the points in the triangulation
Triangulation	Triangulation data structure

**Copy Semantics**

Value. To learn how this affects your use of the class, see [Comparing Handle and Value Classes in the MATLAB Object-Oriented Programming documentation](#).

**Indexing**

TriRep objects support indexing into the triangulation using parentheses (). The syntax is the same as for arrays.

**Examples**

Load a 2-D triangulation and use the TriRep constructor to build an array of the free boundary edges:

```
load trimesh2d
```

This loads triangulation `tri` and vertex coordinates `x, y`:

```
trep = TriRep(tri, x,y);
fe = freeBoundary(trep)';
triplot(trep);
```

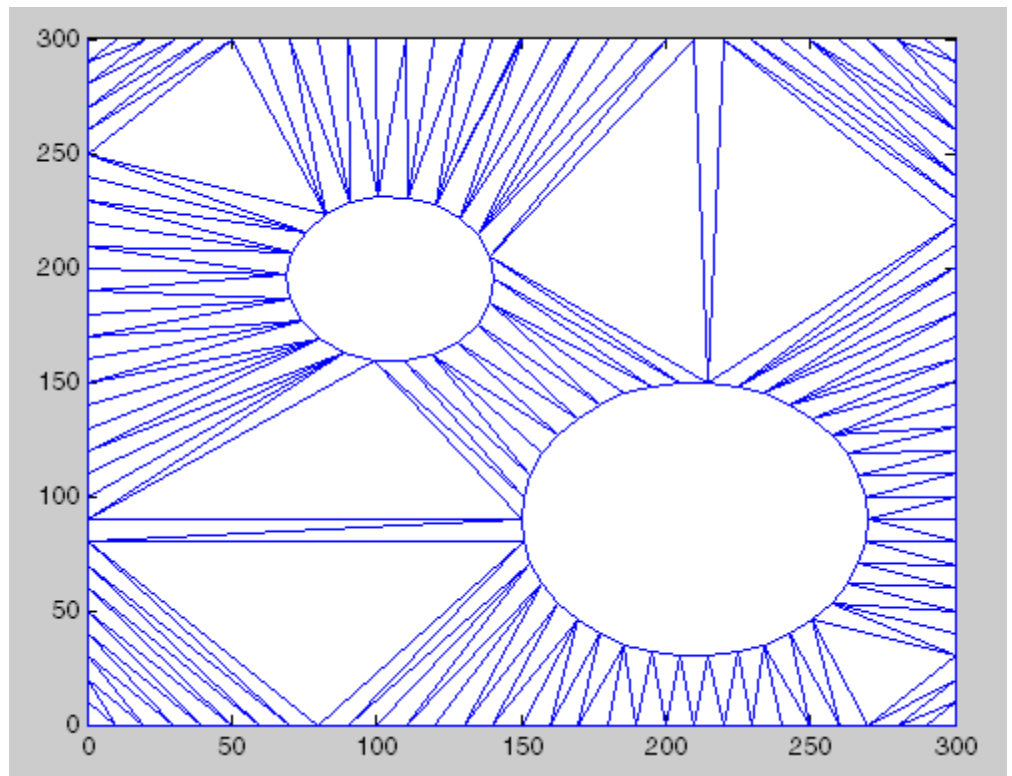

You can add the free edges `fe` to the plot:

```
hold on;
plot(x(fe), y(fe), 'r', 'LineWidth', 2);
hold off;
```

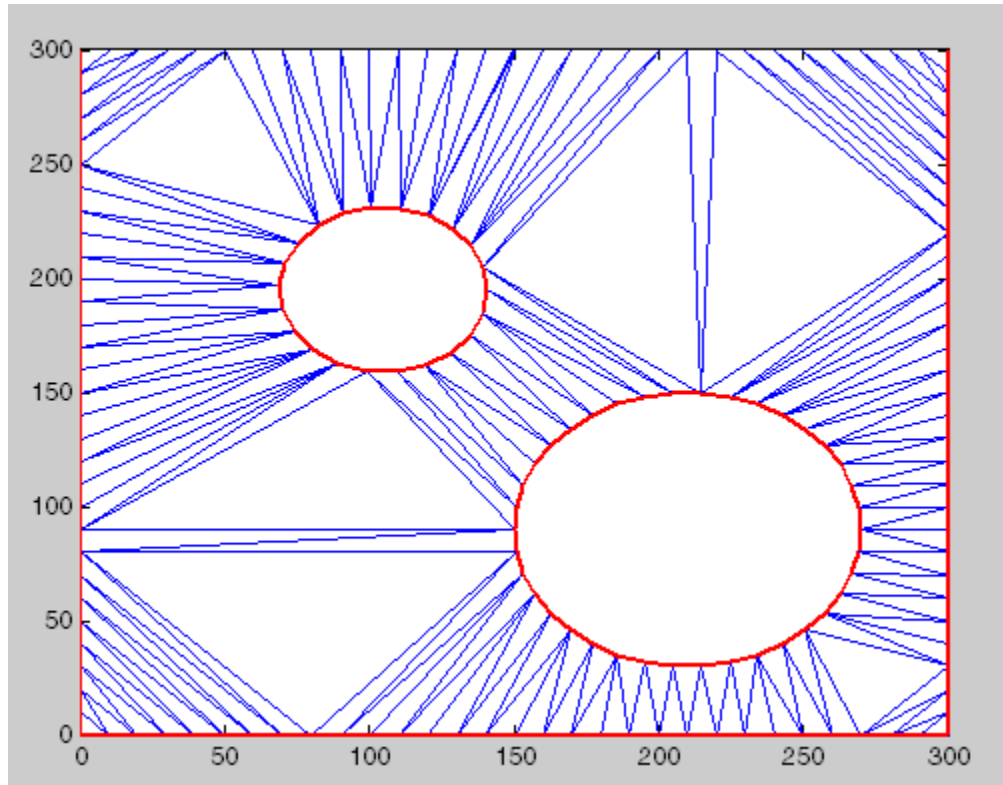

```
axis([-50 350 -50 350]);
axis equal;
```

**See Also**

[delaunayTriangulation](#) | [triangulation](#) | [scatteredInterpolant](#)

# TriRep

---

**Purpose** (Will be removed) Triangulation representation

---

**Note** TriRep will be removed in a future release. Use `triangulation` instead.

---

**Syntax**

```
TR = TriRep(TRI, X, Y)
TR = TriRep(TRI, X, Y, Z)
TR = TriRep(TRI, X)
```

**Description** `TR = TriRep(TRI, X, Y)` creates a 2-D triangulation representation from the triangulation matrix `TRI` and the vertex coordinates `(X, Y)`. `TRI` is an  $m$ -by-3 matrix that defines the triangulation in face-vertex format, where  $m$  is the number of triangles. Each row of `TRI` is a triangle defined by indices into the column vector of vertex coordinates `(X, Y)`.

`TR = TriRep(TRI, X, Y, Z)` creates a 3-D triangulation representation from the triangulation matrix `TRI` and the vertex coordinates `(X, Y, Z)`. `TRI` is an  $m$ -by-3 or  $m$ -by-4 matrix that defines the triangulation in simplex-vertex format, where  $m$  is the number of simplices; triangles or tetrahedra in this case. Each row of `TRI` is a simplex defined by indices into the column vector of vertex coordinates `(X, Y, Z)`.

`TR = TriRep(TRI, X)` creates a triangulation representation from the triangulation matrix `TRI` and the vertex coordinates `X`. `TRI` is an  $m$ -by- $n$  matrix that defines the triangulation in simplex-vertex format, where  $m$  is the number of simplices and  $n$  is the number of vertices per simplex. Each row of `TRI` is a simplex defined by indices into the array of vertex coordinates `X`. `X` is an  $mpts$ -by- $ndim$  matrix where  $mpts$  is the number of points and  $ndim$  is the dimension of the space where the points reside, where  $2 \leq ndim \leq 3$ .

**Examples** Load a 3-D tetrahedral triangulation compute the free boundary. First, load triangulation `tet` and vertex coordinates `X`.

```
load tetmesh
```

Create the triangulation representation and compute the free boundary.

```
trep = TriRep(tet, X);
[tri, Xb] = freeBoundary(trep);
```

## See Also

[scatteredInterpolant](#) | [delaunayTriangulation](#)

# TriScatteredInterp

---

**Purpose** (Will be removed) Interpolate scattered data

---

**Note** TriScatteredInterp will be removed in a future release. Use scatteredInterpolant instead.

---

**Description** TriScatteredInterp is used to perform interpolation on a scattered dataset that resides in 2-D or 3-D space. A scattered data set defined by locations  $X$  and corresponding values  $V$  can be interpolated using a Delaunay triangulation of  $X$ . This produces a surface of the form  $V = F(X)$ . The surface can be evaluated at any query location  $QX$ , using  $QV = F(QX)$ , where  $QX$  lies within the convex hull of  $X$ . The interpolant  $F$  always goes through the data points specified by the sample.

**Definitions** The *Delaunay triangulation* of a set of points is a triangulation such that the unique circle circumscribed about each triangle contains no other points in the set. The *convex hull* of a set of points is the smallest convex set containing all points of the original set. These definitions extend naturally to higher dimensions.

**Construction** TriScatteredInterp (Will be removed) Interpolate scattered data

<b>Properties</b>	$X$	Defines locations of scattered data points in 2-D or 3-D space.
	$V$	Defines value associated with each data point.

Method	Defines method used to interpolate the data .	
	natural	Natural neighbor interpolation
	linear	Linear interpolation (default)
	nearest	Nearest neighbor interpolation

## Copy Semantics

Value. To learn how this affects your use of the class, see [Comparing Handle and Value Classes in the MATLAB Object-Oriented Programming documentation](#).

## Examples

Create a data set:

```
x = rand(100,1)*4-2;
y = rand(100,1)*4-2;
z = x.*exp(-x.^2-y.^2);
```

Construct the interpolant:

```
F = TriScatteredInterp(x,y,z);
```

Evaluate the interpolant at the locations (qx, qy). The corresponding value at these locations is qz:

```
ti = -2:.25:2;
[qx,qy] = meshgrid(ti,ti);
qz = F(qx,qy);
mesh(qx,qy,qz);
hold on;
plot3(x,y,z, 'o');
```

# TriScatteredInterp

---

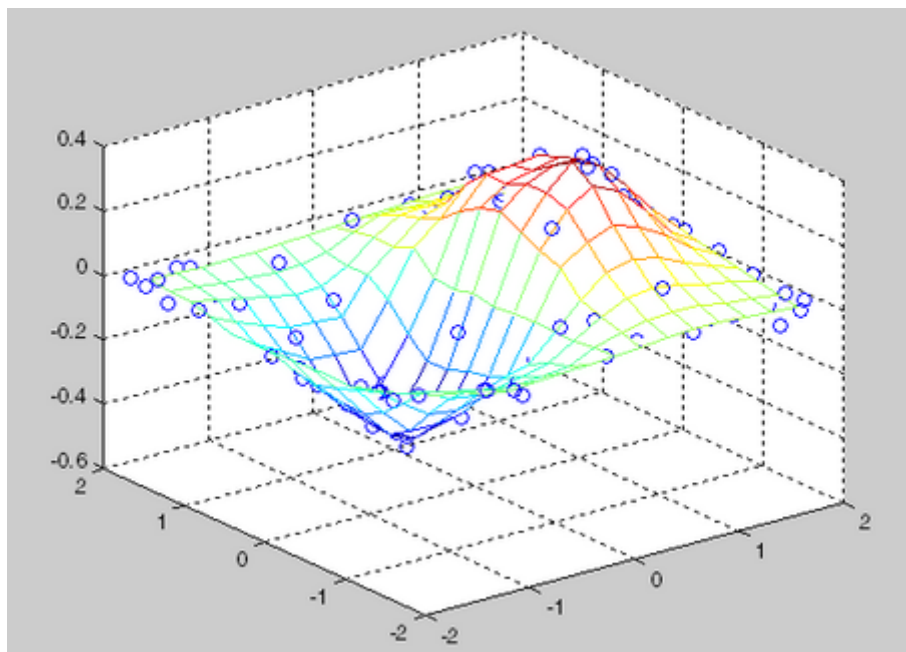

## See Also

[delaunayTriangulation](#) | [interp1](#) | [interp2](#) | [interp3](#) | [meshgrid](#)

**Purpose** (Will be removed) Interpolate scattered data

---

**Note** TriScatteredInterp will be removed in a future release. Use scatteredInterpolant instead.

---

**Syntax**

```
F = TriScatteredInterp()
F = TriScatteredInterp(X, V)
F = TriScatteredInterp(X, Y, V)
F = TriScatteredInterp(X, Y, Z, V)
F = TriScatteredInterp(DT, V)
F = TriScatteredInterp(..., method)
```

**Description**

F = TriScatteredInterp() creates an empty scattered data interpolant. This can subsequently be initialized with sample data points and values (Xdata, Vdata) via F.X = Xdata and F.V = Vdata.

F = TriScatteredInterp(X, V) creates an interpolant that fits a surface of the form  $V = F(X)$  to the scattered data in (X, V). X is a matrix of size mpts-by-ndim, where mpts is the number of points and ndim is the dimension of the space where the points reside (ndim is 2 or 3). The column vector V defines the values at X, where the length of V equals mpts.

F = TriScatteredInterp(X, Y, V) and F = TriScatteredInterp(X, Y, Z, V) allow the data point locations to be specified in alternative column vector format when working in 2-D and 3-D.

F = TriScatteredInterp(DT, V) uses the specified DelaunayTri object DT as a basis for computing the interpolant. DT is a Delaunay triangulation of the scattered data locations, DT.X. The matrix DT.X is of size mpts-by-ndim, where mpts is the number of points and ndim is the dimension of the space where the points reside,  $2 \leq \text{ndim} \leq 3$ . V is a column vector that defines the values at DT.X, where the length of V equals mpts.

F = TriScatteredInterp(..., method) allows selection of the technique method used to interpolate the data.

# TriScatteredInterp

---

## Input Arguments

X	Matrix of size <code>mpts-by-ndim</code> , where <code>mpts</code> is the number of points and <code>ndim</code> is the dimension of the space where the points reside. Input may also be specified as column vectors (X, Y) or (X, Y, Z)	
V	Column vector that defines the values at X, where the length of V equals <code>mpts</code> .	
DT	Delaunay triangulation of the scattered data locations	
method	natural	Natural neighbor interpolation
	linear	Linear interpolation (default)
	nearest	Nearest-neighbor interpolation

## Output Arguments

F	Creates an interpolant that fits a surface of the form $V = F(X)$ to the scattered data.
---	------------------------------------------------------------------------------------------

## Evaluation

To evaluate the interpolant, express the statement in Monge's form  $V_q = F(X_q)$ ,  $V_q = F(X_q, Y_q)$ , or  $V_q = F(X_q, Y_q, Z_q)$  where  $V_q$  is the value of the interpolant at the query location and  $X_q$ ,  $Y_q$ , and  $Z_q$  are the vectors of point locations.

## Definitions

The *Delaunay triangulation* of a set of points is a triangulation such that the unique circle circumscribed about each triangle contains no other points in the set.

## Examples

Create a data set:

```
x = rand(100,1)*4-2;
y = rand(100,1)*4-2;
z = x.*exp(-x.^2-y.^2);
```



Construct the interpolant:

```
F = TriScatteredInterp(x,y,z);
```

Evaluate the interpolant at the locations (qx, qy). The corresponding value at these locations is qz .

```
ti = -2:.25:2;
[qx,qy] = meshgrid(ti,ti);
qz = F(qx,qy);
mesh(qx,qy,qz);
hold on;
plot3(x,y,z, 'o');
```

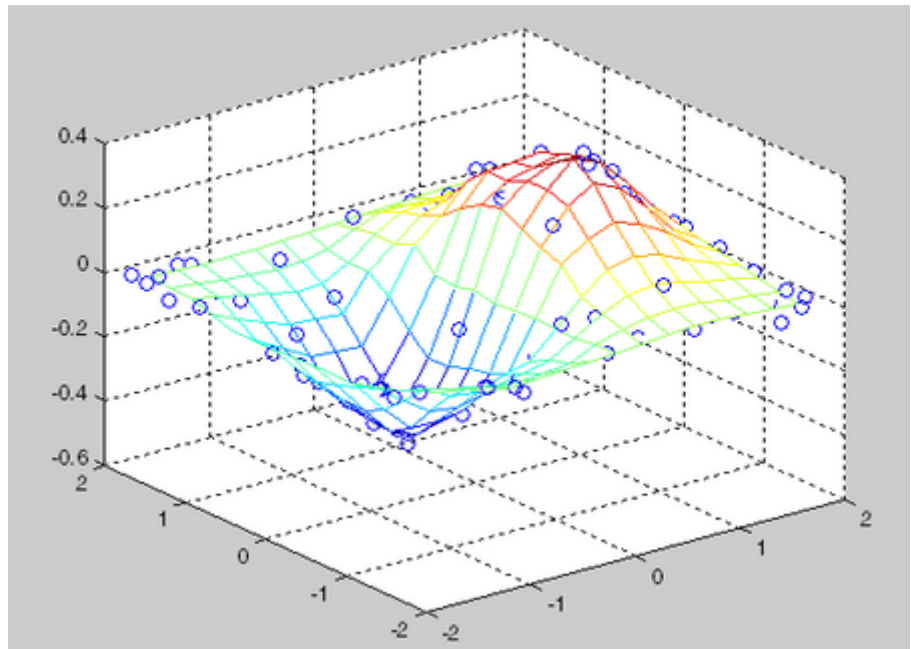

## See Also

[delaunayTriangulation](#) | [interp1](#) | [interp2](#) | [interp3](#) | [meshgrid](#)

# trisurf

---

**Purpose** Triangular surface plot

**Syntax**

```
trisurf(Tri,X,Y,Z,C)
trisurf(Tri,X,Y,Z)
trisurf(TR)
trisurf(...'PropertyName',PropertyValue...)
h = trisurf(...)
```

**Description** `trisurf(Tri,X,Y,Z,C)` displays triangles defined in the  $m$ -by-3 face matrix `Tri` as a surface. Each row of `Tri` defines a single triangular face by indexing into the vectors or matrices that contain the  $X$ ,  $Y$ , and  $Z$  vertices. The color is defined by the vector `C`.

`trisurf(Tri,X,Y,Z)` uses `C=Z` so color is proportional to surface height.

`trisurf(TR)` displays the triangles in a triangulation representation. It uses `C = TR.Points(:,3)` to make sure the surface color is proportional to height.

`trisurf(...'PropertyName',PropertyValue...)` specifies additional patch property names and values for the patch graphics object created by the function.

`h = trisurf(...)` returns a patch handle.

## Examples **Create Triangular Surface Plot**

Create vertex vectors and a face matrix, then create a triangular surface plot.

```
[x,y] = meshgrid(1:15,1:15);
tri = delaunay(x,y);
z = peaks(15);
trisurf(tri,x,y,z)
```

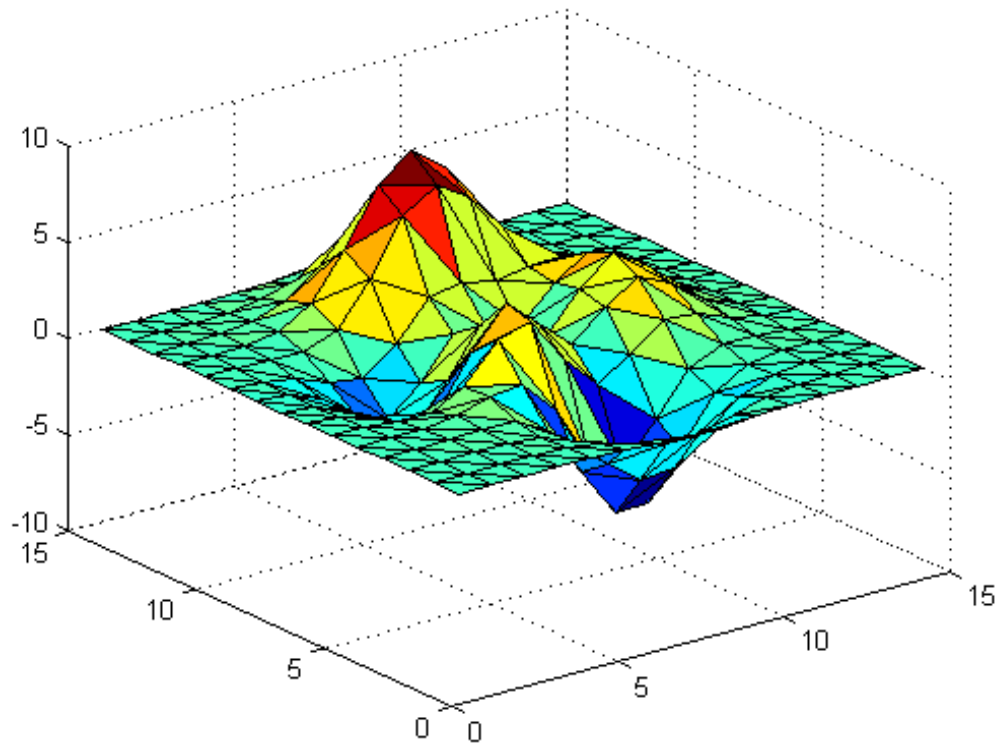

If the surface is in the form of a triangulation representation, you can pass it to `trisurf` alone:

```
tr = triangulation(tri,x(:),y(:),z(:));
trisurf(tr)
```

# trisurf

---

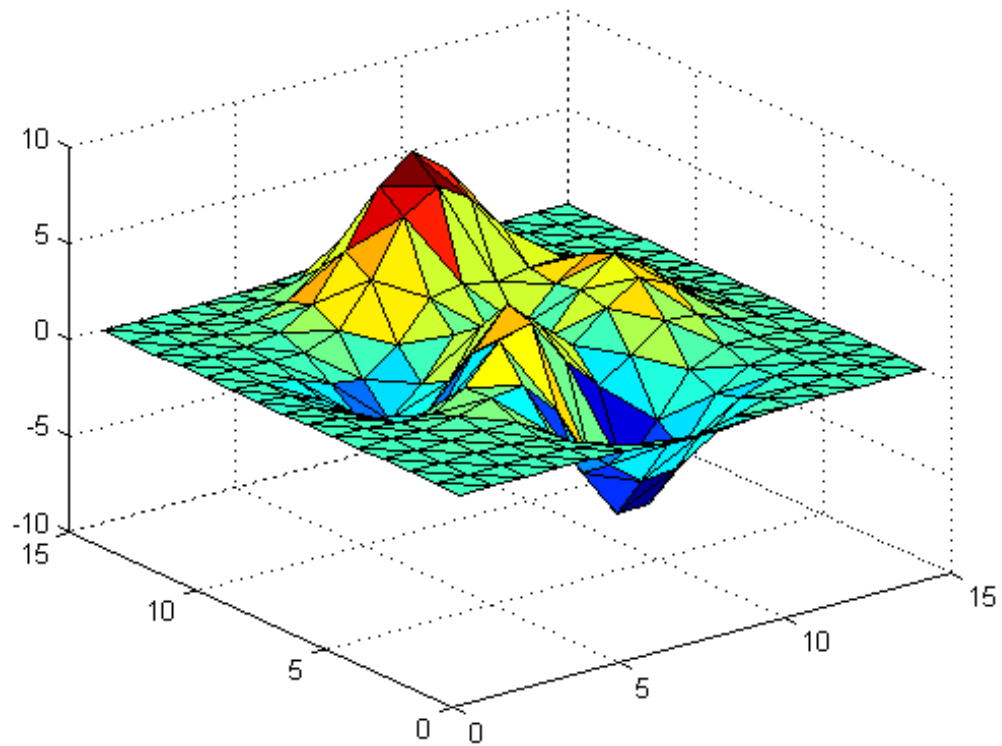

## See Also

[patch](#) | [surf](#) | [tetramesh](#) | [trimesh](#) | [triplot](#) | [delaunay](#) | [triangulation](#) | [delaunayTriangulation](#)

**Purpose** Upper triangular part of matrix

**Syntax**  
 $U = \text{triu}(X)$   
 $U = \text{triu}(X,k)$

**Description**  $U = \text{triu}(X)$  returns the upper triangular part of  $X$ .  
 $U = \text{triu}(X,k)$  returns the element on and above the  $k$ th diagonal of  $X$ .  
 $k = 0$  is the main diagonal,  $k > 0$  is above the main diagonal, and  $k < 0$  is below the main diagonal.

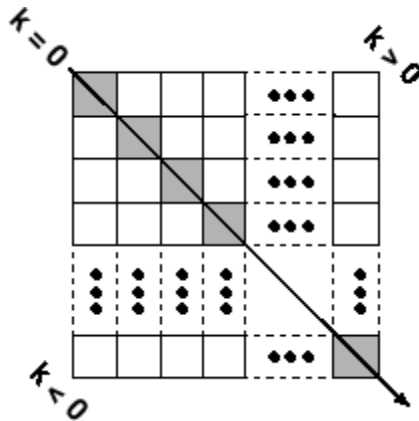

**Examples** `triu(ones(4,4),-1)`

ans =

```

1 1 1 1
1 1 1 1
0 1 1 1
0 0 1 1
```

**See Also** `diag` | `tril`

# true

---

**Purpose** Logical 1 (true)

**Syntax**

```
true
T = true(n)
T = true(sz)
T = true(sz1,...,szN)
T = true(__ , 'like', p)
```

**Description** true is shorthand for logical(1).

`T = true(n)` is an n-by-n matrix of logical ones.

`T = true(sz)` is an array of logical ones where the size vector, `sz`, defines `size(T)`. For example, `true([2 3])` returns a 2-by-3 array of logical ones.

`T = true(sz1,...,szN)` is a `sz1`-by-...-by-`szN` array of logical ones where `sz1,...,szN` indicates the size of each dimension. For example, `true(2,3)` returns a 2-by-3 array of logical ones.

`T = true( __ , 'like', p)` returns an array of logical ones of the same sparsity as the logical variable `p` using any of the previous size syntaxes.

## Input Arguments

### **n - Size of square matrix**

integer

Size of square matrix, specified as an integer. `n` sets the output array size to n-by-n. For example, `true(3)` returns a 3-by-3 array of logical ones.

- If `n` is 0, then `T` is an empty matrix.
- If `n` is negative, then it is treated as 0.

### **Data Types**

int8 | int16 | int32 | int64 | uint8 | uint16 | uint32 | uint64

**sz - Size vector**

row vector of integers

Size vector, specified as a row vector of integers. For example, `true([2 3])` returns a 2-by-3 array of logical ones.

- If the size of any dimension is 0, then T is an empty array.
- If the size of any dimension is negative, then it is treated as 0.
- If any trailing dimensions greater than 2 have a size of 1, then the output, T, does not include those dimensions.

**Data Types**

int8 | int16 | int32 | int64 | uint8 | uint16 | uint32 | uint64

**sz1,...,szN - Size inputs**

comma-separated list of integers

Size inputs, specified by a comma-separated list of integers. For example, `true(2,3)` returns a 2-by-3 array of logical ones.

- If the size of any dimension is 0, then T is an empty array.
- If the size of any dimension is negative, then it is treated as 0.
- If any trailing dimensions greater than 2 have a size of 1, then the output, T, does not include those dimensions.

**Data Types**

int8 | int16 | int32 | int64 | uint8 | uint16 | uint32 | uint64

**p - Prototype**

logical variable

Prototype, specified as a logical variable.

**Data Types**

single | double | int8 | int16 | int32 | int64 | uint8 | uint16 | uint32 | uint64

**Complex Number Support:** Yes

# true

---

## Output Arguments

### T - Output of logical ones

scalar | vector | matrix | N-D array

Output of logical ones, returned as a scalar, vector, matrix, or N-D array.

### Data Types

logical

## Examples

### Generate Square Matrix of Logical Ones

Use `true` to generate a 3-by-3 square matrix of logical ones.

```
A = true(3)
class(A)
```

```
A =
 1 1 1
 1 1 1
 1 1 1
```

```
ans =
logical
```

The result is of class `logical`.

### Generate Array of Logical Ones with Arbitrary Dimensions

Use `true` to generate a 3-by-2-by-2 matrix of logical ones.

```
true(3,2,2)
```

```
ans(:,:,1) =
 1 1
 1 1
 1 1
```

```
ans(:,:,2) =
 1 1
 1 1
 1 1
```



Alternatively, you can use a size vector to specify the size of the matrix.

```
true([3,2,2])
```

```
ans(:,:,1) =
 1 1
 1 1
 1 1
```

```
ans(:,:,2) =
 1 1
 1 1
 1 1
```

Note that specifying multiple vector inputs returns an error.

### Execute Logic Statement

true along with false can be used to execute logic statements.

Test the logical statement  $\sim(A \text{ and } B) \equiv (\sim A) \text{ or } (\sim B)$  for  $A = \text{logical true}$  and  $B = \text{logical false}$ .

```
~(true & false) == (~true) | (~false)
```

```
ans =
 1
```

The result is logical 1 (true), since the logical statements on both sides of the equation are equivalent. This logical statement is an instance of De Morgan's Law.

### Generate Logical Array of Selected Sparsity

Generate a logical array of the same sparsity as the selected array.

```
A = logical(sparse(5,3));
whos A
T = true(4,'like',A);
whos T
```

# true

---

Name	Size	Bytes	Class	Attributes
A	5x3	41	logical	sparse
Name	Size	Bytes	Class	Attributes
T	4x4	184	logical	sparse

The output array *T* has the same `sparse` attribute and data-type as the specified array *A*.

## Tips

- `true(n)` is much faster and more memory efficient than `logical(true(n))`.

## See Also

`false` | `logical`

## Concepts

- “Class Support for Array-Creation Functions”

**Purpose** Execute statements and catch resulting errors

**Syntax**

```
try
 statements
catch exception
 statements
end
```

**Description** try and catch blocks allow you to override the default error behavior for a set of program statements. If any statement in a try block generates an error, program control goes immediately to the catch block, which contains your error handling statements.

*exception* is an optional MException object input to the catch block that allows you to identify the error.

Both try and catch blocks can contain nested try/catch statements.

**Examples** Provide more information about a dimension mismatch error:

```
A = rand(3);
B = ones(5);

try
 C = [A; B];
catch err

 % Give more information for mismatch.
 if (strcmp(err.identifier, 'MATLAB:catenate:dimensionMismatch'))

 msg = ['Dimension mismatch occurred: First argument has ', ...
 num2str(size(A,2)), ' columns while second has ', ...
 num2str(size(B,2)), ' columns.'];
 error('MATLAB:myCode:dimensions', msg);

 % Display any other errors as usual.
 else
 rethrow(err);
 end
end
```

# try, catch

---

```
 end

 end % end try/catch
```

---

Catch an error when reading an image file, and try adjusting the file extension to resolve the error (.jpg and .jpeg are similar, as are .tif and .tiff):

```
function imageData = readImage(filename)
try
 imageData = imread(filename);
catch exception

 % Is the error because MATLAB could not find the file?
 if ~exist(filename, 'file')

 % Check for common typos in the extension.
 [~, ~, extension] = fileparts(filename);
 switch extension
 case '.jpg'
 altFilename = strrep(filename, '.jpg', '.jpeg');
 case '.jpeg'
 altFilename = strrep(filename, '.jpeg', '.jpg');
 case '.tif'
 altFilename = strrep(filename, '.tif', '.tiff');
 case '.tiff'
 altFilename = strrep(filename, '.tiff', '.tif');
 otherwise
 rethrow(exception);
 end

 % Try again, with modified filename.
 try
 imageData = imread(altFilename);
 catch exception2
 % Rethrow original error.
 end
 end
end
```

```
 rethrow(exception)
 end

 else
 rethrow(exception)
 end

end
```

## See Also

error | assert | MException

# tscollection

---

**Purpose** Create `tscollection` object

**Syntax**

```
tsc = tscollection(TimeSeries)
tsc = tscollection(Time)
tsc = tscollection(...,'Parameter',Value,...)
```

**Description**

`tsc = tscollection(TimeSeries)` creates a `tscollection` object `tsc` with one or more `timeseries` objects already in the MATLAB workspace. The argument `TimeSeries` can be a

- Single `timeseries` object
- Cell array of `timeseries` objects

`tsc = tscollection(Time)` creates an empty `tscollection` object with the time vector `Time`. When time values are date strings, you must specify `Time` as a cell array of date strings.

`tsc = tscollection(...,'Parameter',Value,...)` creates a `tscollection` object with optional parameter-value pairs you enter after specifying either a time vector or a `timeseries` object. You can specify the following parameter:

- `Name` — String that specifies the name of this `tscollection` object

## Tips

### Definition: Time Series Collection

A time series collection object is a MATLAB variable that groups several time series with a common time vector. The time series that you include in the collection are called members of this collection.

### Properties of Time Series Collection Objects

This table lists the properties of the `tscollection` object. You can specify the `Time`, `TimeSeries`, and `Name` properties as input arguments in the constructor.

Property	Description
Name	tscollection name as a string. This can differ from the tscollection name in the MATLAB workspace.
Time	<p>When TimeInfo.StartDate is empty, values are measured relative to 0 . When TimeInfo.StartDate is defined, values represent date strings measured relative to the StartDate.</p> <p>The length of Time must be the same as the first or the last dimension of Data for each collection .</p>
TimeInfo	<p>Contains fields for contextual information about Time:</p> <ul style="list-style-type: none"> <li>• <b>Units</b> — Time units with any of the following values: 'weeks', 'days', 'hours', 'minutes', 'seconds', 'milliseconds', 'microseconds', 'nanoseconds'</li> <li>• <b>Start</b> — Start time</li> <li>• <b>End</b> — End time (read only)</li> <li>• <b>Increment</b> — Interval between subsequent time values. NaN when times are not uniformly sampled.</li> <li>• <b>Length</b> — Length of the time vector (read only)</li> <li>• <b>Format</b> — String defining the date string display format. See datestr.</li> <li>• <b>StartDate</b> — Date string defining the reference date. See setabstime (tscollection).</li> <li>• <b>UserData</b> — Any additional user-defined information</li> </ul>

## Examples

The following example shows how to create a tscollection object.

1 Import the sample data.

```
load count.dat
```

# tscollection

---

- 2** Create three `timeseries` objects to store each set of data:

```
count1 = timeseries(count(:,1),1:24,'name', 'ts1');
count2 = timeseries(count(:,2),1:24,'name', 'ts2');
count3 = timeseries(count(:,3),1:24,'name', 'ts3');
```

- 3** Create a `tscollection` object named `tsc` and add to it two out of three time series already in the MATLAB workspace, by using the following syntax:

```
tsc = tscollection({count1 count2},'name','tsc')
```

## See Also

`addts` | `datestr` | `setabstime` (`tscollection`) | `timeseries`



**Purpose** Construct event object for `timeseries` object

**Syntax**

```
e = tsdata.event(Name,Time)
e = tsdata.event(Name,Time,'Datenum')
```

**Description**

`e = tsdata.event(Name,Time)` creates an event object with the specified `Name` that occurs at the time `Time`. `Time` can either be a real value or a date string.

`e = tsdata.event(Name,Time,'Datenum')` uses `'Datenum'` to indicate that the `Time` value is a serial date number generated by the `datenum` function. The `Time` value is converted to a date string after the event is created.

**Tips** You add events by using the `addevent` method.

Fields of the `tsdata.event` object include the following:

- `EventData` — MATLAB array that stores any user-defined information about the event
- `Name` — String that specifies the name of the event
- `Time` — Time value when this event occurs, specified as a real number
- `Units` — Time units
- `StartDate` — A reference date, specified in MATLAB `datestr` format. `StartDate` is empty when you have a numerical (non-date-string) time vector.

# tsearchn

---

**Purpose** N-D closest simplex search

**Syntax** `t = tsearchn(X,TRI,XI)`  
`[t,P] = tsearchn(X,TRI,XI)`

**Description** `t = tsearchn(X,TRI,XI)` returns the indices `t` of the enclosing simplex of the Delaunay triangulation `TRI` for each point in `XI`. `X` is an `m`-by-`n` matrix, representing `m` points in `N`-dimensional space. `XI` is a `p`-by-`n` matrix, representing `p` points in `N`-dimensional space. `tsearchn` returns `NaN` for all points outside the convex hull of `X`. `tsearchn` requires a triangulation `TRI` of the points `X` obtained from `delaunayn`.

`[t,P] = tsearchn(X,TRI,XI)` also returns the barycentric coordinate `P` of `XI` in the simplex `TRI`. `P` is a `p`-by-`n+1` matrix. Each row of `P` is the barycentric coordinate of the corresponding point in `XI`. It is useful for interpolation.

**See Also** `delaunayTriangulation`

**Purpose** Open Time Series Tools GUI

**Compatibility** `tstool` will be removed in a future release.

- To create a time series object, use `timeseries`.
- To create a time series collection with one or more `timeseries` objects, use `tscollection`.
- To open a time series object or collection in the Variables editor, use `openvar`.
- To plot a time series object, use `plot`.

`tstool(sldata)` and `tstool(ModelDataLogs, 'replace')` have been removed. To view logged signal data, use the Simulink Simulation Data Inspector instead.

**Syntax**

```
tstool
tstool(ts)
tstool(tsc)
```

**Description**

`tstool` starts the Time Series Tools GUI without loading any data.

`tstool(ts)` starts the Time Series Tools GUI and loads the time-series object `ts` from the MATLAB workspace.

`tstool(tsc)` starts the Time Series Tools GUI and loads the time-series collection object `tsc` from the MATLAB workspace.

**See Also** `timeseries` | `tscollection`

**How To**

- “View Logged Signal Data with the Simulation Data Inspector”

# type

---

**Purpose** Display contents of file

**Syntax** `type('filename')`  
`type filename`

**Description** `type('filename')` displays the contents of the specified file in the MATLAB Command Window. Use the full path for `filename`, or use a MATLAB relative partial path.

If you do not specify a file extension and there is no `filename` file without an extension, the `type` function adds the `.m` extension by default. The `type` function checks the folders specified in the MATLAB search path, which makes it convenient for listing the contents of files on the screen. Use `type` with `more on` to see the listing one screen at a time.

`type filename` is the command form of the syntax.

**Examples** `type('foo.bar')` lists the contents of the file `foo.bar`.

`type foo` lists the contents of the file `foo`. If `foo` does not exist, `type foo` lists the contents of the file `foo.m`.

**See Also** `cd` | `dbtype` | `delete` | `dir` | `more` | `path` | `what` | `who`

**Purpose** Convert data types without changing underlying data

**Syntax** `Y = typecast(X, type)`

**Description** `Y = typecast(X, type)` converts a numeric value in `X` to the data type specified by `type`. Input `X` must be a full, noncomplex, numeric scalar or vector. The `type` input is a string set to one of the following: 'uint8', 'int8', 'uint16', 'int16', 'uint32', 'int32', 'uint64', 'int64', 'single', or 'double'.

`typecast` is different from the MATLAB `cast` function in that it does not alter the input data. `typecast` always returns the same number of bytes in the output `Y` as were in the input `X`. For example, casting the 16-bit integer 1000 to `uint8` with `typecast` returns the full 16 bits in two 8-bit segments (3 and 232) thus keeping its original value ( $3 \times 256 + 232 = 1000$ ). The `cast` function, on the other hand, truncates the input value to 255.

The output of `typecast` can be formatted differently depending on what system you use it on. Some computer systems store data starting with its most significant byte (an ordering called *big-endian*), while others start with the least significant byte (called *little-endian*).

---

**Note** MATLAB issues an error if `X` contains fewer values than are needed to make an output value.

---

## Examples

### Example 1

This example converts between data types of the same size:

```
typecast(uint8(255), 'int8')
ans =
 -1
```

```
typecast(int16(-1), 'uint16')
ans =
```

65535

## Example 2

Set X to a 1-by-3 vector of 32-bit integers, then cast it to an 8-bit integer type:

```
X = uint32([1 255 256])
X =
 1 255 256
```

Running this on a little-endian system produces the following results. Each 32-bit value is divided up into four 8-bit segments:

```
Y = typecast(X, 'uint8')
Y =
 1 0 0 0 255 0 0 0 0 1 0 0
```

The third element of X, 256, exceeds the 8 bits that it is being converted to in Y(9) and thus overflows to Y(10):

```
Y(9:12)
ans =
 0 1 0 0
```

Note that `length(Y)` is equal to `4.*length(X)`. Also note the difference between the output of `typecast` versus that of `cast`:

```
Z = cast(X, 'uint8')
Z =
 1 255 255
```

## Example 3

This example casts a smaller data type (`uint8`) into a larger one (`uint16`). Displaying the numbers in hexadecimal format makes it easier to see just how the data is being rearranged:

```
format hex
X = uint8([44 55 66 77])
X =
```

```
2c 37 42 4d
```

The first `typecast` is done on a big-endian system. The four 8-bit segments of the input data are combined to produce two 16-bit segments:

```
Y = typecast(X, 'uint16')
Y =
 2c37 424d
```

The second is done on a little-endian system. Note the difference in byte ordering:

```
Y = typecast(X, 'uint16')
Y =
 372c 4d42
```

You can format the little-endian output into big-endian (and vice versa) using the `swapbytes` function:

```
Y = swapbytes(typecast(X, 'uint16'))
Y =
 2c37 424d
```

## Example 4

This example attempts to make a 32-bit value from a vector of three 8-bit values. MATLAB issues an error because there are an insufficient number of bytes in the input:

```
format hex
typecast(uint8([120 86 52]), 'uint32')
```

Error using `typecast`  
Too few input values to make output type.

Repeat the example, but with a vector of four 8-bit values, and it returns the expected answer:

```
typecast(uint8([120 86 52 18]), 'uint32')
ans =
```

# typecast

---

12345678

## **See Also**

cast | class | swapbytes



<b>Purpose</b>	Create container object to exclusively manage radio buttons and toggle buttons
<b>Syntax</b>	<pre>uibbuttongroup('PropertyName1',Value1,'PropertyName2',Value2,...) handle = uibbuttongroup(...)</pre>
<b>Description</b>	<p>A <code>uibbuttongroup</code> groups components and manages exclusive selection behavior for radio buttons and toggle buttons that it contains. It can also contain other user interface controls, axes, <code>uipanel</code>s, and <code>uibbuttongroups</code>. It cannot contain ActiveX controls.</p> <pre>uibbuttongroup('PropertyName1',Value1,'PropertyName2',Value2,...)</pre> creates a visible container component in the current figure window. This component manages exclusive selection behavior for <code>uicontrol</code> s of style <code>radiobutton</code> and <code>togglebutton</code> .
	<pre>handle = uibbuttongroup(...)</pre> creates a <code>uibbuttongroup</code> object and returns a handle to it in <code>handle</code> .
	A <code>uibbuttongroup</code> object can have axes, <code>uicontrol</code> , <code>uipanel</code> , and <code>uibbuttongroup</code> objects as children. However, only <code>uicontrol</code> s of style <code>radiobutton</code> and <code>togglebutton</code> are managed by the component.
	When programming a button group, you do not code callbacks for the individual buttons; instead, use its <code>SelectionChangeFcn</code> callback to manage responses to selections. The following example illustrates how you use <code>uibbuttongroup</code> event data to do this.
	For the children of a <code>uibbuttongroup</code> object, the <code>Position</code> property is interpreted relative to the button group. If you move the button group, the children automatically move with it and maintain their positions in the button group.
	If you have a button group that contains a set of radio buttons and toggle buttons and you want:
	<ul style="list-style-type: none"><li>• An immediate action to occur when a radio button or toggle button is selected, you must include the code to control the radio and toggle buttons in the button group's <code>SelectionChangeFcn</code> callback function, not in the individual toggle button <code>Callback</code> functions. See the</li></ul>

# uibuttongroup

---

SelectionChangeFcn property and the example on this reference page for more information.

- Another component such as a push button to base its action on the selection, then that component's `Callback` callback can get the handle of the selected radio button or toggle button from the button group's `SelectedObject` property.

Use the `Parent` property to specify the parent as a figure, `uipanel`, or `uibuttongroup`. If you do not specify a parent, `uibuttongroup` adds the button group to the current figure. If no figure exists, one is created.

See the `Uibuttongroup Properties` reference page for more information.

After creating a `uibuttongroup`, you can set and query its property values using `set` and `get`. Run `get(handle)` to see a list of properties and their current values. Run `set(handle)` to see a list of object properties you can set and their legal values.

## Tips

If you set the `Visible` property of a `uibuttongroup` object to `'off'`, any child objects it contains (buttons, button groups, etc.) become invisible along with the `uibuttongroup` panel itself. However, doing this does *not* affect the settings of the `Visible` property of any of its child objects, even though all of them remain invisible until the button group's visibility is set to `'on'`. `uipanel` components also behave in this manner.

Do not use the `CreateFcn` of a button group to create the buttons it contains. You can toggle buttons created in the button group `CreateFcn` on and off, but clicking them does not trigger the button group `SelectionChangeCallback` and the buttons do not display the expected mutually-exclusive behavior.

## Examples

This example creates a `uibuttongroup` with three radio buttons. It manages the radio buttons with the `SelectionChangeFcn` callback, `selcbk`.

When you select a new radio button, `selcbk` displays the `uibuttongroup` handle on one line, the `EventName`, `OldValue`, and `NewValue` fields

of the event data structure on a second line, and the value of the SelectedObject property on a third line.

```
% Create the button group.
h = uibuttongroup('visible','off','Position',[0 0 .2 1]);
% Create three radio buttons in the button group.
u0 = uicontrol('Style','radiobutton','String','Option 1',...
 'pos',[10 350 100 30],'parent',h,'HandleVisibility','off');
u1 = uicontrol('Style','radiobutton','String','Option 2',...
 'pos',[10 250 100 30],'parent',h,'HandleVisibility','off');
u2 = uicontrol('Style','radiobutton','String','Option 3',...
 'pos',[10 150 100 30],'parent',h,'HandleVisibility','off');
% Initialize some button group properties.
set(h,'SelectionChangeFcn',@selcbk);
set(h,'SelectedObject',[]); % No selection
set(h,'Visible','on');
```

For the SelectionChangeFcn callback, selcbk, the source and event data structure arguments are available only if selcbk is called using a function handle. See SelectionChangeFcn for more information.

```
function selcbk(source,eventdata)
disp(source);
disp([eventdata.EventName, ' ',...
 get(eventdata.OldValue,'String'),' ', ...
 get(eventdata.NewValue,'String')]);
disp(get(get(source,'SelectedObject'),'String'));
```

# uibuttongroup

---

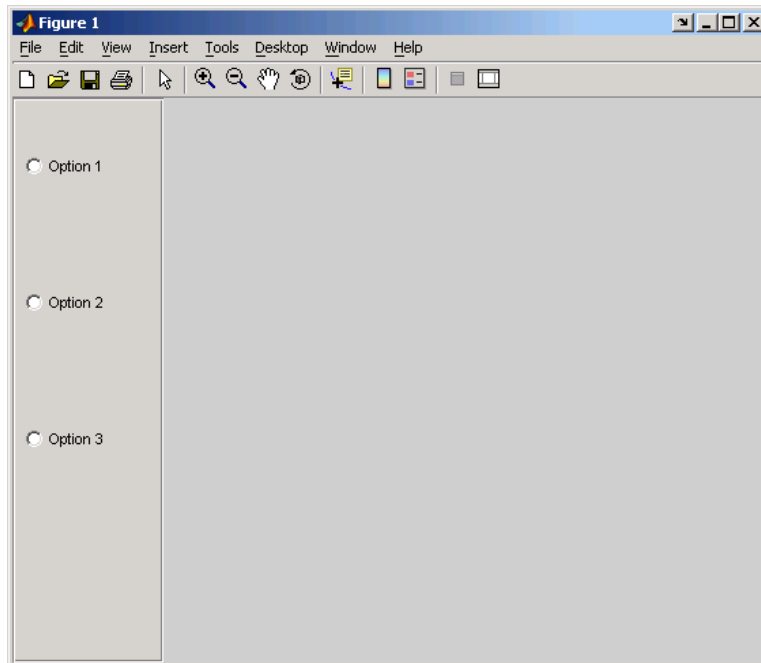

If you click Option 2 with no option selected, the SelectionChangeFcn callback, selcbk, displays:

```
3.0011
```

```
SelectionChanged Option 2
Option 2
```

If you then click Option 1, the SelectionChangeFcn callback, selcbk, displays:

```
3.0011
```

```
SelectionChanged Option 2 Option 1
Option 1
```

**See Also**      `uicontrol` | `uipanel`

# Uibuttongroup Properties

---

## Purpose

Describe button group properties

## Modifying Properties

You can set and query graphics object properties in two ways:

- The Property Inspector is an interactive tool that enables you to see and change object property values. The Property inspector is available from the GUIDE Layout Editor **View** menu, or use the `inspect` function at the command line.
- The `set` and `get` functions enable you to set and query the values of properties.

Uibuttongroup takes its default property values from `uipanel`. To set a `uibuttongroup` default property value, set the default for the corresponding `uipanel` property. Note that you can set no default values for the `uibuttongroup` `SelectedObject` and `SelectionChangeFcn` properties.

For more information about changing the default value of a property see “Setting Default Property Values”. For an example, see the `CreateFcn` property.

## Uibuttongroup Properties

This section describes all properties useful to `uibuttongroup` objects and lists valid values. Curly braces `{ }` enclose default values.

Property Name	Description
<code>BackgroundColor</code>	Color of the button group background
<code>BeingDeleted</code>	This object is being deleted
<code>BorderType</code>	Type of border around the button group
<code>BorderWidth</code>	Width of the button group border in pixels
<code>BusyAction</code>	Interruption of other callback routines
<code>ButtonDownFcn</code>	Button-press callback routine
<code>Children</code>	All children of the button group

# Uibuttongroup Properties

Property Name	Description
Clipping	Clipping of child axes, panels, and button groups to the button group. Does not affect child user interface controls (uicontrol)
CreateFcn	Callback routine executed during object creation
DeleteFcn	Callback routine executed during object deletion
FontAngle	Title font angle
FontName	Title font name
FontSize	Title font size
FontUnits	Title font units
FontWeight	Title font weight
ForegroundColor	Title font color and color of 2-D border line
HandleVisibility	Handle accessibility from command line and GUIs
HighlightColor	3-D frame highlight color
Interruptible	Callback routine interruption mode
Parent	uibuttongroup object's parent
Position	Button group position relative to parent figure, panel, or button group
ResizeFcn	User-specified resize routine
SelectedObject	Currently selected uicontrol of style radiobutton or togglebutton
SelectionChangeFcn	Callback routine executed when the selected radio button or toggle button changes
ShadowColor	3-D frame shadow color
Tag	User-specified object identifier

# Uibuttongroup Properties

---

Property Name	Description
Title	Title string
TitlePosition	Location of title string in relation to the button group
Type	Object class
UIContextMenu	Associate context menu with the button group
Units	Units used to interpret the position vector
UserData	User-specified data
Visible	Button group visibility  <b>Note</b> Controls the visibility of a uibuttongroup and of its child axes, uibuttongroups, uipanel, and child uicontrols. Setting it does not change their Visible property.

BackgroundColor  
ColorSpec

*Color of the uibuttongroup background.* A three-element RGB vector or one of the MATLAB predefined names, specifying the background color. See the ColorSpec reference page for more information on specifying color.

BeingDeleted  
on | {off} (read-only)

*This object is being deleted.* Mechanism to determine if objects are in the process of being deleted. MATLAB sets the BeingDeleted property to on when the object's delete function callback is called (see the DeleteFcn property). It remains set to on while the delete function executes, after which the object no longer exists.



For example, an object's delete function calls other functions that act on a number of different objects. If a function does not need to perform an action on an about-be-deleted object, it can check the object's `BeingDeleted` property before acting.

## BorderType

`none` | `{etchedin}` | `etchedout` |  
`beveledin` | `beveledout` | `line`

*Border of the uibuttongroup area.* Used to define the button group area graphically. Etched and beveled borders provide a 3-D look. Use the `HighlightColor` and `ShadowColor` properties to specify the border color of etched and beveled borders. A line border is 2-D. Use the `ForegroundColor` property to specify its color.

## BorderWidth

integer

*Width of the button group border.* The width of the button group borders in pixels. The default border width is 1 pixel. 3-D borders wider than 3 may not appear correctly at the corners.

## BusyAction

`cancel` | `{queue}`

### *Callback queuing*

Determines how MATLAB handles the execution of interrupting callbacks.

A *running* callback is the currently executing callback. The *interrupting* callback is the callback that tries to interrupt the *running* callback. The `BusyAction` property of the *interrupting* callback determines how MATLAB handles its execution. When the `BusyAction` property is set to:

- `'queue'` — Puts the *interrupting* callback in a queue to be processed after the *running* callback finishes execution.

# Uibuttongroup Properties

---

- 'cancel' — Discards the *interrupting* callback as MATLAB finishes execution.

For information about how the `Interruptible` property of the callback controls whether other callbacks can interrupt the *running* callback, see the `Interruptible` property description.

`ButtonDownFcn`  
string or function handle

*Button-press callback routine.* A callback routine that executes when you press a mouse button while the pointer is in a 5-pixel wide border around the `uibuttongroup`. This is useful for implementing actions to interactively modify object properties, such as size and position, when they are clicked on (using the `selectmoveresize` function, for example).

If you define this routine as a string, the string can be a valid MATLAB expression or the name of a code file. The expression executes in the MATLAB workspace.

`Children`  
vector of handles

*Children of the uibuttongroup.* A vector containing the handles of all children of the `uibuttongroup`. Although a `uibuttongroup` manages only `uicontrols` of style `radiobutton` and `togglebutton`, its children can be axes, `uipanel`s, `uibuttongroup`s, and other `uicontrol`s. You can use this property to reorder the children.

`Clipping`  
{on} | off

*Clipping mode.* By default, MATLAB clips a `uibuttongroup`'s child axes, `uipanel`s, and `uibuttongroup`s to the `uibuttongroup` rectangle. If you set `Clipping` to `off`, the axis, `uipanel`, or `uibuttongroup` display outside the button group rectangle. This

property does not affect child uicontrols which, by default, can display outside the button group rectangle.

## CreateFcn

string or function handle

*Callback routine executed during object creation.* The specified function executes when MATLAB creates a `uibuttongroup` object. MATLAB sets all property values for the `uibuttongroup` before executing the `CreateFcn` callback so these values are available to the callback. Within the function, use `gcb0` to get the handle of the `uibuttongroup` being created.

Setting this property on an existing `uibuttongroup` object has no effect.

To define a default `CreateFcn` callback for all new `uibuttongroups` you must define the same default for all `uipanel`s. This default applies unless you override it by specifying a different `CreateFcn` callback when you call `uibuttongroup`. For example, the code

```
set(0, 'DefaultUipanelCreateFcn', 'set(gcb0, ...
 ' 'FontName', 'arial', 'FontSize', 12)')
```

creates a default `CreateFcn` callback that runs whenever you create a new panel or button group. It sets the default font name and font size of the `uipanel` or `uibuttongroup` title.

To override this default and create a button group whose `FontName` and `FontSize` properties are set to different values, call `uibuttongroup` with code similar to

```
hpt = uibuttongroup(..., 'CreateFcn', 'set(gcb0, ...
 ' 'FontName', 'times', 'FontSize', 14)')
```

# Uibuttongroup Properties

---

---

**Note** To override a default `CreateFcn` callback you must provide a new callback and not just provide different values for the specified properties. This is because the `CreateFcn` callback runs after the property values are set, and can override property values you have set explicitly in the `uibuttongroup` call. In the example above, if instead of redefining the `CreateFcn` property for this `uibuttongroup`, you had explicitly set `FontSize` to 14, the default `CreateFcn` callback would have set `FontSize` back to the system dependent default.

---

Do not call `copyobj` or `textwrap` (which calls `copyobj`) inside a `CreateFcn`. The act of copying the `uicontrol` object fires the `CreateFcn` repeatedly, which raises a series of error messages after exceeding the root object's `RecursionLimit` property.

See “Function Handle Callbacks” for information on how to use function handles to define a callback function.

`DeleteFcn`  
string or function handle

*Callback routine executed during object deletion.* A callback routine that executes when you delete the `uibuttongroup` object (e.g., when you issue a delete command or clear the figure containing the `uibuttongroup`). MATLAB executes the routine before destroying the object's properties so these values are available to the callback routine. The handle of the object whose `DeleteFcn` is being executed is accessible only through the root `CallbackObject` property, which you can query using `gcbo`.

`FontAngle`  
{normal} | italic | oblique

*Character slant used in the Title.* MATLAB uses this property to select a font from those available on your particular system.

Setting this property to *italic* or *oblique* selects a slanted version of the font, when it is available on your system.

FontName  
string

*Font family used in the Title.* The name of the font in which to display the `Title`. To display and print properly, this must be a font that your system supports. The default font is system dependent. To eliminate the need to hard code the name of a fixed-width font, which may not display text properly on systems that do not use ASCII character encoding (such as in Japan), set `FontName` to the string `FixedWidth`. This string value is case insensitive.

```
set(uicontrol_handle,'FontName','FixedWidth')
```

This then uses the value of the root `FixedWidthFontName` property, which can be set to the appropriate value for a locale from `startup.m` in the end user's environment. Setting the root `FixedWidthFontName` property causes an immediate update of the display to use the new font.

FontSize  
integer

*Title font size.* A number specifying the size of the font in which to display the `Title`, in units determined by the `FontUnits` property. The default size is system dependent.

FontUnits  
inches | centimeters | normalized |  
{points} | pixels

*Title font size units.* Normalized units interpret `FontSize` as a fraction of the height of the `uibuttongroup`. When you resize the `uibuttongroup`, MATLAB modifies the screen `FontSize` accordingly. `pixels`, `inches`, `centimeters`, and `points` are absolute units (1 point = 1/72 inch).

# Uibuttongroup Properties

---

## FontWeight

light | {normal} | demi | bold

*Weight of characters in the title.* MATLAB uses this property to select a font from those available on your particular system. Setting this property to bold causes MATLAB to use a bold version of the font, when it is available on your system.

## ForegroundColor

ColorSpec

*Color used for title font and 2-D border line.* A three-element RGB vector or one of the MATLAB predefined names, specifying the font or line color. See the ColorSpec reference page for more information on specifying color.

## HandleVisibility

{on} | callback | off

*Control access to object's handle.* This property determines when an object's handle is visible in its parent's list of children. When a handle is not visible in its parent's list of children, it is not returned by functions that obtain handles by searching the object hierarchy or querying handle properties. This includes `get`, `findobj`, `gca`, `gcf`, `gco`, `newplot`, `cla`, `clf`, and `close`. Neither is the handle visible in the parent figure's `CurrentObject` property. Handles that are hidden are still valid. If you know an object's handle, you can `set` and `get` its properties, and pass it to any function that operates on handles.

- Handles are always visible when `HandleVisibility` is on.
- Setting `HandleVisibility` to `callback` causes handles to be visible from within callback routines or functions invoked by callback routines, but not from within functions invoked from the command line. This provides a means to protect GUIs from command-line users, while allowing callback routines to have complete access to object handles.

- Setting `HandleVisibility` to `off` makes handles invisible at all times. This may be necessary when a callback routine invokes a function that might potentially damage the GUI (such as evaluating a user-typed string), and so temporarily hides its own handles during the execution of that function.

---

**Note** Uicontrols of style `radiobutton` and `togglebutton` that are managed by a `uibuttongroup` should not be accessed outside the button group. Set the `HandleVisibility` of such radio buttons and toggle buttons to `off` or `callback` to prevent inadvertent access.

---

You can set the root `ShowHiddenHandles` property to `on` to make all handles visible, regardless of their `HandleVisibility` settings. This does not affect the values of the `HandleVisibility` properties.

`HighlightColor`  
`ColorSpec`

*3-D frame highlight color.* A three-element RGB vector or one of the MATLAB predefined names, specifying the highlight color. See the `ColorSpec` reference page for more information on specifying color.

`Interruptible`  
`off` | `{on}`

*Callback routine interruption*

Controls whether MATLAB can interrupt an object's callback function when subsequent callbacks attempt to interrupt it.

For user interface objects, the `Interruptible` property affects the callbacks for these properties only:

# Uibuttongroup Properties

---

- ButtonDownFcn
- KeyPressFcn
- KeyReleaseFcn
- WindowButtonDownFcn
- WindowButtonMotionFcn
- WindowButtonUpFcn
- WindowKeyPressFcn
- WindowKeyReleaseFcn
- WindowScrollWheelFcn

A *running* callback is the currently executing callback. The *interrupting* callback is the callback that tries to interrupt the *running* callback. MATLAB handles both callbacks based on the `Interruptible` property of the object of the *running* callback.

When the `Interruptible` property is set to:

- 'off', MATLAB finishes execution of the *running* callback without any interruptions
- 'on', these conditions apply:
  - If there is a `drawnow`, `figure`, `getframe`, `waitfor`, or `pause` command in the *running* callback, then MATLAB executes the *interrupting* callbacks which are already in the queue and returns to finish execution of the current callback.
  - If one of the above functions is not in the *running* callback, then MATLAB finishes execution of the current callback without any interruption.

The `BusyAction` property of the object of interrupting callback determines whether the callback should be ignored or should be put in the queue.



# Uibuttongroup Properties

---

Setting the `Interruptible` property to on (default), allows a callback from other user interface objects to interrupt callback functions originating from this object.

---

**Note** MATLAB does not save the state of properties or the display when an interruption occurs. For example, the handle returned by the `gca` or `gcf` command may be changed as another callback is executed.

---

After the function that interrupts a callback completes, the callback resumes execution where it halted when interrupted. For more information, see “Control Callback Execution and Interruption”.

---

**Note** If the interrupting callback is a `DeleteFcn` or `CreateFcn` callback, or a figure’s `CloseRequest` or `ResizeFcn` callback, it interrupts an executing callback regardless of the value of that object’s `Interruptible` property. The interrupting callback starts execution at the next `drawnow`, `figure`, `getframe`, `pause`, or `waitfor` statement. An object’s `ButtonDownFcn` or `Callback` routine is processed according to the rules described previously in this section.

---

## Parent

handle

*Uibuttongroup parent.* The handle of the `uibuttongroup`’s parent figure, `uipanel`, or `uibuttongroup`. You can move a `uibuttongroup` object to another figure, `uipanel`, or `uibuttongroup` by setting this property to the handle of the new parent.

## Position

position rectangle

# Uibuttongroup Properties

---

*Size and location of uibuttongroup relative to parent.* The rectangle defined by this property specifies the size and location of the button group within the parent figure window, uipanel, or uibuttongroup. Specify `Position` as

```
[left bottom width height]
```

`left` and `bottom` are the distance from the lower-left corner of the parent object to the lower-left corner of the `uibuttongroup` object. `width` and `height` are the dimensions of the `uibuttongroup` rectangle, including the title. All measurements are in units specified by the `Units` property.

`ResizeFcn`  
string or function handle

*Resize callback routine.* MATLAB executes this callback routine whenever a user resizes the `uibuttongroup` and the figure `Resize` property is set to `on`, or in GUIDE, the **Resize behavior** option is set to `Other`. You can query the `uibuttongroup Position` property to determine its new size and position. During execution of the callback routine, the handle to the figure being resized is accessible only through the root `CallbackObject` property, which you can query using `gcbo`.

You can use `ResizeFcn` to maintain a GUI layout that is not directly supported by the MATLAB `Position/Units` paradigm.

For example, consider a GUI layout that maintains an object at a constant height in pixels and attached to the top of the figure, but always matches the width of the figure. The following `ResizeFcn` accomplishes this; it keeps the `uicontrol` whose `Tag` is `'StatusBar'` 20 pixels high, as wide as the figure, and attached to the top of the figure. Note the use of the `Tag` property to retrieve the `uicontrol` handle, and the `gcbo` function to retrieve the figure handle. Also note the defensive programming regarding figure `Units`, which the callback requires to be in pixels in order to work

correctly, but which the callback also restores to their previous value afterwards.

```
u = findobj('Tag','StatusBar');
fig = gcbo;
old_units = get(fig,'Units');
set(fig,'Units','pixels');
figpos = get(fig,'Position');
upos = [0, figpos(4) - 20, figpos(3), 20];
set(u,'Position',upos);
set(fig,'Units',old_units);
```

You can change the figure `Position` from within the `ResizeFcn` callback; however, the `ResizeFcn` is not called again as a result.

Note that the `print` command can cause the `ResizeFcn` to be called if the `PaperPositionMode` property is set to `manual` and you have defined a resize function. If you do not want your resize function called by `print`, set the `PaperPositionMode` to `auto`.

See “Function Handle Callbacks” for information on how to use function handles to define the callback function.

## Selected

on | off (read only)

*Is object selected?* This property indicates whether the button group is selected. When this property is on, MATLAB displays selection handles if the `SelectionHighlight` property is also on. You can, for example, define the `ButtonDownFcn` function to set this property, allowing users to select the object with the mouse.

## SelectedObject

scalar handle

*Currently selected radio button or toggle button uicontrol* in the managed group of components. Use this property to determine the currently selected component or to initialize selection of one of

# Uibuttongroup Properties

---

the radio buttons or toggle buttons. By default, `SelectedObject` is set to the first uicontrol radio button or toggle button that is added. Set it to `[]` if you want no selection. Note that `SelectionChangeFcn` does not execute when this property is set by the user.

`SelectionChangeFcn`  
string or function handle

Callback routine executed when the selected radio button or toggle button changes. If this routine is called as a function handle, `uibuttongroup` passes it two arguments. The first argument, `source`, is the handle of the `uibuttongroup`. The second argument, `eventdata`, is an event data structure that contains the fields shown in the following table.

Event Data Structure Field	Description
<code>EventName</code>	'SelectionChanged'
<code>OldValue</code>	Handle of the object selected before this event. <code>[]</code> if none was selected.
<code>NewValue</code>	Handle of the currently selected object.

If you have a button group that contains a set of radio buttons and/or toggle buttons and you want an immediate action to occur when a radio button or toggle button is selected, you must include the code to control the radio and toggle buttons in the button group's `SelectionChangeFcn` callback function, not in the individual toggle button `Callback` functions.

If you want another component such as a push button to base its action on the selection, then that component's `Callback` callback can get the handle of the selected radio button or toggle button from the button group's `SelectedObject` property.

---

**Note** For GUIDE GUIs, `hObject` contains the handle of the selected radio button or toggle button. See “Callbacks for Specific Components” for more information.

---

**SelectionHighlight**

`{on} | off`

*Object highlighted when selected.* When the `Selected` property is on, MATLAB indicates the selected state by drawing four edge handles and four corner handles. When `SelectionHighlight` is off, MATLAB does not draw the handles.

**ShadowColor**

`ColorSpec`

*3-D frame shadow color.* `ShadowColor` is a three-element RGB vector or one of the MATLAB predefined names, specifying the shadow color. See the `ColorSpec` reference page for more information on specifying color.

**Tag**

string

*User-specified object identifier.* The `Tag` property provides a means to identify graphics objects with a user-specified label. You can define `Tag` as any string.

With the `findobj` function, you can locate an object with a given `Tag` property value. This saves you from defining object handles as global variables. For example, this function call returns the handles of all children (of the specified figures) that have the `Tag` value `'FormatTb'`.

```
h = findobj(figurehandles,'Tag','FormatTb')
```

# Uibuttongroup Properties

---

## Title

string

*Title string.* The text displayed in the button group title. You can position the title using the `TitlePosition` property.

Vertical slash (`|`) characters are not interpreted as line breaks and instead show up in the text displayed in the `uibuttongroup` title.

Setting a property value to `default`, `remove`, or `factory` produces the effect described in “Defining Default Values”. To set `Title` to one of these words, you must precede the word with the backslash character. For example,

```
hp = uibuttongroup('Title','\default');
```

## TitlePosition

{lefttop} | centertop | righttop |  
leftbottom | centerbottom | rightbottom

*Location of the title.* This property determines the location of the title string, in relation to the `uibuttongroup`.

## Type

string (read-only)

*Object class.* This property identifies the kind of graphics object. For `uibuttongroup` objects, `Type` is always the string `'uipanel'`, because its default properties derive from `uipanel`.

## UIContextMenu

handle

*Associate a context menu with a uibuttongroup.* Assign this property the handle of a `Uicontextmenu` object. MATLAB displays the context menu whenever you right-click the `uibuttongroup`. Use the `uicontextmenu` function to create the context menu.

## Units

inches | centimeters | {normalized} |  
points | pixels | characters

*Units of measurement.* MATLAB uses these units to interpret the `Position` property. For the button group itself, units are measured from the lower-left corner of its parent figure window, panel, or button group. For children of the button group, they are measured from the lower-left corner of the button group.

- Normalized units map the lower-left corner of the button group or figure window to (0,0) and the upper-right corner to (1.0,1.0).
- inches, centimeters, and points are absolute units (1 point = 1/72 inch).
- Character units are characters using the default system font; the width of one character is the width of the letter x, the height of one character is the distance between the baselines of two lines of text.

If you change the value of `Units`, it is good practice to return it to its default value after completing your computation so as not to affect other functions that assume `Units` is set to the default value.

## UserData

matrix

*User-specified data.* Any data you want to associate with the `uibuttongroup` object. MATLAB does not use this data, but you can access it using `set` and `get`.

## Visible

{on} | off

*Uibuttongroup visibility.* By default, a `uibuttongroup` object is visible. When set to 'off', the `uibuttongroup` is not visible, as

# Uibuttongroup Properties

---

are all child objects of the button group. When a button group is hidden in this manner, you can still query and set its properties.

---

**Note** The value of a uibuttongroup's `Visible` property determines whether its child components, such as axes, buttons, uipanel, and other uibuttongroups, are visible. However, changing the `Visible` property of a button group does *not* change the settings of the `Visible` property of its child components even though hiding the button group causes them to be hidden.

---



<b>Purpose</b>	Create context menu
<b>Syntax</b>	<code>handle = uicontextmenu('PropertyName',PropertyValue,...)</code>
<b>Description</b>	<p><code>handle = uicontextmenu('PropertyName',PropertyValue,...)</code> creates a context menu, which is a menu that appears when the user right-clicks on a graphics object. See Uicontextmenu Properties for more information.</p> <p>In its initial state, a context menu has no menu items. You create menu items within the context menu using the <code>uimenu</code> function. Menu items appear in the order in which the <code>uimenu</code> statements appear. You then associate a context menu with an object by specifying the handle of the context menu as the value for its <code>UIContextMenu</code> property.</p>

## Examples

The following statements define a context menu associated with a line on a graph. The menu items enable you to change the line style.

```
% Create axes and save handle
hax = axes;
% Plot three lines
plot(rand(20,3));
% Define a context menu; it is not attached to anything
hcmenu = uicontextmenu;
% Define callbacks for context menu
% items that change linestyle
hcb1 = ['set(gcf,'LineStyle','--')'];
hcb2 = ['set(gcf,'LineStyle',':')'];
hcb3 = ['set(gcf,'LineStyle','-')'];
% Define the context menu items and install their callbacks
item1 = uimenu(hcmenu,'Label','dashed','Callback',hcb1);
item2 = uimenu(hcmenu,'Label','dotted','Callback',hcb2);
item3 = uimenu(hcmenu,'Label','solid','Callback',hcb3);
% Locate line objects
hlines = findall(hax,'Type','line');
% Attach the context menu to each line
for line = 1:length(hlines)
```

# uicontextmenu

---

```
set(hlines(line),'uicontextmenu',hcmenu)
end
```

When you right-click on any line (or, on a Macintosh computer with a one-button mouse, press the **Ctrl** key and click), the context menu appears, as shown in the following figure.

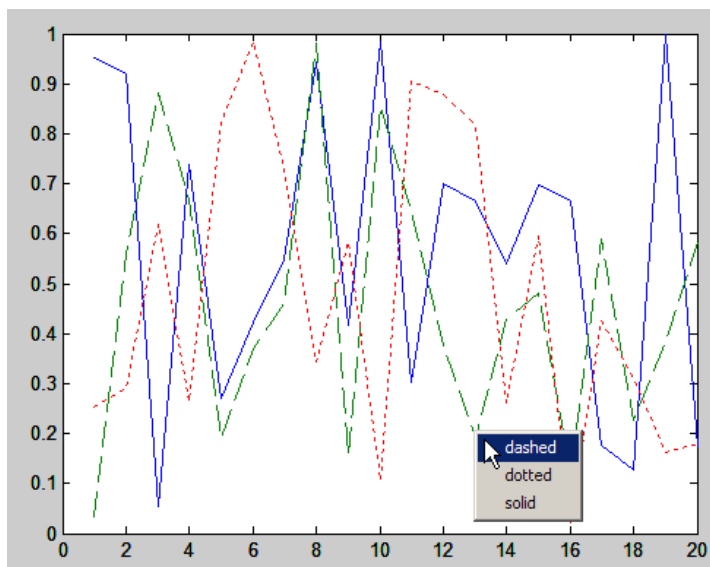

To make context menus available immediately, attach them to lines at the time they are plotted. Therefore, when creating a GUI that uses such context menus, place code like the preceding in the callbacks that perform plotting for the GUI.

A best practice is to use function handles for callbacks. Only define callbacks as strings for simple actions. For example, you can add check marks to menu items (using the `Checked` `uimenu` property) to indicate the current style for each line. To manage the check marks, define the menu item callbacks as function handles. Place the code for the functions in the GUI code file rather than placing callback strings in the figure.

Generally, you need to attach context menus to lines at the time they are plotted in order to be sure that the menus are immediately available. Therefore, code such as the above could be placed in or called from the callbacks that perform plotting for the GUI.

## **Tutorials**

See “Context Menus” in the MATLAB Creating Graphical User Interfaces documentation.

## **See Also**

`uibbuttongroup` | `uicontrol` | `uimenu` | `uipanel`

# Uicontextmenu Properties

---

## Purpose

Describe context menu properties

## Modifying Properties

You can set and query graphics object properties in two ways:

- The Property Inspector is an interactive tool that enables you to see and change object property values. The Property inspector is available from GUIDE, or use the `inspect` function at the command line.
- The `set` and `get` functions enable you to set and query the values of properties.

For more information about changing the default value of a property see “Setting Default Property Values”. For an example, see the `CreateFcn` property.

## Uicontextmenu Properties

This section lists all properties useful to `uicontextmenu` objects along with valid values and descriptions of their use. Curly braces `{}` enclose default values.

Property	Purpose
<code>BeingDeleted</code>	This object is being deleted
<code>BusyAction</code>	Callback routine interruption
<code>Callback</code>	Control action
<code>Children</code>	The <code>uimenu</code> s defined for the <code>uicontextmenu</code>
<code>CreateFcn</code>	Callback routine executed during object creation
<code>DeleteFcn</code>	Callback routine executed during object deletion
<code>HandleVisibility</code>	Whether handle is accessible from command line and GUIs
<code>Interruptible</code>	Callback routine interruption mode
<code>Parent</code>	<code>Uicontextmenu</code> object's parent

Property	Purpose
Position	Location of uicontextmenu when Visible is on
Tag	User-specified object identifier
Type	Class of graphics object
UserData	User-specified data
Visible	Uicontextmenu visibility

## BeingDeleted

on | {off} (read-only)

*This object is being deleted.* Mechanism to determine if objects are in the process of being deleted. MATLAB sets the **BeingDeleted** property to **on** when the object's delete function callback is called (see the **DeleteFcn** property). It remains set to **on** while the delete function executes, after which the object no longer exists.

For example, an object's delete function calls other functions that act on a number of different objects. If a function does not need to perform an action on an about-be-deleted object, it can check the object's **BeingDeleted** property before acting.

## BusyAction

cancel | {queue}

*Callback queuing*

Determines how MATLAB handles the execution of interrupting callbacks.

A *running* callback is the currently executing callback. The *interrupting* callback is the callback that tries to interrupt the *running* callback. The **BusyAction** property of the *interrupting* callback determines how MATLAB handles its execution. When the **BusyAction** property is set to:

# Uicontextmenu Properties

---

- 'queue' — Puts the *interrupting* callback in a queue to be processed after the *running* callback finishes execution.
- 'cancel' — Discards the *interrupting* callback as MATLAB finishes execution.

For information about how the `Interruptible` property of the callback controls whether other callbacks can interrupt the *running* callback, see the `Interruptible` property description.

**Callback**  
string

*Control action.* A routine that executes whenever you right-click an object for which a context menu is defined. The routine executes immediately before the context menu is posted. Define this routine as a string that is a valid MATLAB expression or the name of a code file. The expression executes in the MATLAB workspace.

**Children**  
matrix

The `uimenu` items defined for the `uicontextmenu`.

**CreateFcn**  
string or function handle

*Callback routine executed during object creation.* The specified function executes when MATLAB creates a `uicontextmenu` object. MATLAB sets all property values for the `uicontextmenu` before executing the `CreateFcn` callback so these values are available to the callback. Within the function, use `gcb0` to get the handle of the `uicontextmenu` being created.

Setting this property on an existing `uicontextmenu` object has no effect.

You can define a default `CreateFcn` callback for all new `uicontextmenus`. This default applies unless you override it by specifying a different `CreateFcn` callback when you call `uicontextmenu`. For example, the code

```
set(0,'DefaultUicontextmenuCreateFcn','set(gcbo,...
 'Visible','on'))
```

creates a default `CreateFcn` callback that runs whenever you create a new context menu. It sets the default `Visible` property of a context menu.

To override this default and create a context menu whose `Visible` property is set to a different value, call `uicontextmenu` with code similar to

```
hpt = uicontextmenu(...,'CreateFcn','set(gcbo,...
 'Visible','off'))
```

---

**Note** To override a default `CreateFcn` callback you must provide a new callback and not just provide different values for the specified properties. This is because the `CreateFcn` callback runs after the property values are set, and can override property values you have set explicitly in the `uicontextmenu` call. In the example above, if instead of redefining the `CreateFcn` property for this `uicontextmenu`, you had explicitly set `Visible` to `off`, the default `CreateFcn` callback would have set `Visible` back to the default, i.e., `on`.

---

Do not call `copyobj` or `textwrap` (which calls `copyobj`) inside a `CreateFcn`. The act of copying the `uicontrol` object fires the `CreateFcn` repeatedly, which raises a series of error messages after exceeding the root object's `RecursionLimit` property.

For information on the syntax of callback functions, see [Function Handle Callbacks](#).

# Uicontextmenu Properties

---

## DeleteFcn

string or function handle

*Delete uicontextmenu callback routine.* A callback routine that executes when you delete the `uicontextmenu` object (for example, when you issue a `delete` command or clear the figure containing the `uicontextmenu`). MATLAB executes the routine before destroying the object's properties so these values are available to the callback routine.

The handle of the object whose `DeleteFcn` is being executed is accessible only through the root `CallbackObject` property, which you can query using `gcbo`.

For information on the syntax of callback functions, see [Function Handle Callbacks](#).

## HandleVisibility

{on} | callback | off

*Control access to object's handle.* This property determines when an object's handle is visible in its parent's list of children. When a handle is not visible in its parent's list of children, it is not returned by functions that obtain handles by searching the object hierarchy or querying handle properties. This includes `get`, `findobj`, `gca`, `gcf`, `gco`, `newplot`, `cla`, `clf`, and `close`. Neither is the handle visible in the parent figure's `CurrentObject` property. Handles that are hidden are still valid. If you know an object's handle, you can `set` and `get` its properties, and pass it to any function that operates on handles.

- Handles are always visible when `HandleVisibility` is `on`.
- Setting `HandleVisibility` to `callback` causes handles to be visible from within callback routines or functions invoked by callback routines, but not from within functions invoked from the command line. This provides a means to protect GUIs from



command-line users, while allowing callback routines to have complete access to object handles.

- Setting `HandleVisibility` to `off` makes handles invisible at all times. This might be necessary when a callback routine invokes a function that might potentially damage the GUI (such as evaluating a user-typed string), and so temporarily hides its own handles during the execution of that function.

You can set the root `ShowHiddenHandles` property to `on` to make all handles visible, regardless of their `HandleVisibility` settings. This does not affect the values of the `HandleVisibility` properties.

`Interruptible`  
`off | {on}`

### *Callback routine interruption*

Controls whether MATLAB can interrupt an object's callback function when subsequent callbacks attempt to interrupt it.

For user interface objects, the `Interruptible` property affects the callbacks for these properties only:

- `ButtonDownFcn`
- `KeyPressFcn`
- `KeyReleaseFcn`
- `WindowButtonDownFcn`
- `WindowButtonMotionFcn`
- `WindowButtonUpFcn`
- `WindowKeyPressFcn`
- `WindowKeyReleaseFcn`
- `WindowScrollWheelFcn`

# Uicontextmenu Properties

---

A *running* callback is the currently executing callback. The *interrupting* callback is the callback that tries to interrupt the *running* callback. MATLAB handles both callbacks based on the `Interruptible` property of the object of the *running* callback.

When the `Interruptible` property is set to:

- 'off', MATLAB finishes execution of the *running* callback without any interruptions
- 'on', these conditions apply:
  - If there is a `drawnow`, `figure`, `getframe`, `waitfor`, or `pause` command in the *running* callback, then MATLAB executes the *interrupting* callbacks which are already in the queue and returns to finish execution of the current callback.
  - If one of the above functions is not in the *running* callback, then MATLAB finishes execution of the current callback without any interruption.

The `BusyAction` property of the object of interrupting callback determines whether the callback should be ignored or should be put in the queue.

Setting the `Interruptible` property to `on` (default), allows a callback from other user interface objects to interrupt callback functions originating from this object.

---

**Note** MATLAB does not save the state of properties or the display when an interruption occurs. For example, the handle returned by the `gca` or `gcf` command may be changed as another callback is executed.

---

After the function that interrupts a callback completes, the callback resumes execution where it halted when interrupted.

For more information, see “Control Callback Execution and Interruption”.

---

**Note** If the interrupting callback is a `DeleteFcn` or `CreateFcn` callback, or a figure’s `CloseRequest` or `ResizeFcn` callback, it interrupts an executing callback regardless of the value of that object’s `Interruptible` property. The interrupting callback starts execution at the next `drawnow`, `figure`, `getframe`, `pause`, or `waitfor` statement. An object’s `ButtonDownFcn` or `Callback` routine is processed according to the rules described previously in this section.

---

## Parent

handle

*Uicontextmenu’s parent.* The handle of the `uicontextmenu`’s parent object, which must be a figure.

## Position

vector

*Uicontextmenu’s position.* A two-element vector that defines the location of a context menu posted by setting the `Visible` property value to `on`. Specify `Position` as

[x y]

where vector elements represent the horizontal and vertical distances in pixels from the bottom left corner of the figure window.

## Tag

string

*User-specified object label.* The `Tag` property provides a means to identify graphics objects with a user-specified label. This

# Uicontextmenu Properties

---

is particularly useful when constructing interactive graphics programs that would otherwise need to define object handles as global variables or pass them as arguments between callback routines. You can define `Tag` as any string.

## Type

string

*Class of graphics object.* For `uicontextmenu` objects, `Type` is always the string `'uicontextmenu'`.

## UserData

matrix

*User-specified data.* Any data you want to associate with the `uicontextmenu` object. MATLAB does not use this data, but you can access it using `set` and `get`.

## Visible

on | {off}

*Uicontextmenu visibility.* The `Visible` property can be used in two ways:

- Its value indicates whether the context menu is currently posted. While the context menu is posted, the property value is `on`; when the context menu is not posted, its value is `off`.
- Its value can be set to `on` to force the posting of the context menu. Similarly, setting the value to `off` forces the context menu to be removed. When used in this way, the `Position` property determines the location of the posted context menu.

## See Also

`uicontextmenu`

**Purpose**

Create user interface control object

**Syntax**

```
handle = uicontrol('Name',Value,...)
handle = uicontrol(parent,'Name',Value,...)
handle = uicontrol
uicontrol(uich)
```

**Description**

`handle = uicontrol('Name',Value,...)` creates a `uicontrol` and assigns the specified properties and values to it. It assigns the default values to any properties you do not specify. The default `uicontrol` style is `pushbutton`. The default parent is the current figure. See the `Uicontrol Properties` reference page for more information.

`handle = uicontrol(parent,'Name',Value,...)` creates a `uicontrol` in the object specified by the handle, `parent`. If you also specify a different value for the `Parent` property, the value of the `Parent` property takes precedence. `parent` can be the handle of a figure, `uipanel`, or `uibuttongroup`.

`handle = uicontrol` creates a push button in the current figure. The `uicontrol` function assigns all properties their default values.

`uicontrol(uich)` gives focus to the `uicontrol` specified by the handle, `uich`.

`uicontrol` creates a `uicontrol` graphics objects (user interface controls), which you use to implement graphical user interfaces.

**Specifying the Uicontrol Style**

When selected, most `uicontrol` objects perform a predefined action. To create a specific type of `uicontrol`, set the `Style` property as one of the strings that follow. You can specify a partial string if it is unique among all the styles. For example, instead of `'radiobutton'`, you can specify `'radio'`.

- `'checkbox'` – A check box generates an action when you select it. Use check boxes to provide a number of independent choices. To activate a check box, click the mouse button on the object. The check box updates its appearance when its state changes.

- 'edit' – Editable text fields enable you to enter or modify text values. Use editable text when you want free text as input. To enable multiple lines of text, set `Max-Min>1`. Multiline edit boxes provide a vertical scroll bar for scrolling. The arrow keys also provide a way to scroll. Obtain the current text by getting the `String` property. The `String` property does not update as you type in an edit box. To execute the callback routine for an edit text control, type in the desired text and then do one of the following:
  - Click another component, the menu bar, or the background of the GUI.
  - For a single line editable text box, press **Enter**.
  - For a multiline editable text box, press **Ctrl+Enter**.
- 'frame'

---

**Note** MathWorks recommends you use `uipanel` or `uibuttongroup` instead of frames.

GUIDE continues to support frames in those GUIs that contain them, but the frame component does not appear in the GUIDE Layout Editor component palette.

---

- 'listbox' – List boxes display a list of items, from which you can select one or more items. Unlike pop-up menus, list boxes do not expand when clicked. The `Min` and `Max` properties control the selection mode:
  - To enable multiple selection of items, set `Max-Min > 1`.
  - To enable selection of only one item at a time, set `Max-Min <= 1`.

The `Value` property stores the row indexes of currently selected list box items, and is a vector value when you select multiple items. After any mouse button up event that changes the `Value` property, MATLAB evaluates the list box's callback routine. To delay action

when multiple items can be selected, you can associate a "Done" push button with the list box. Use the callback for that button to evaluate the list box `Value` property.

List boxes with the `Enable` property set to `on` differentiate between single and double left clicks. MATLAB sets the figure `SelectionType` property to `normal` or `open` accordingly before evaluating the list box `Callback` property. For enabled list boxes, **Ctrl**-left click and **Shift**-left click also set the figure `SelectionType` property to `normal` or `open`, respectively indicating a single or double click.

- `'popupmenu'` – Pop-up menus (also known as drop-down menus or combo boxes) display a list of choices when you open them with a button-press. When closed, a pop-up menu indicates the current choice. Pop-up menus are useful when you want to provide a number of mutually exclusive choices, but do not want to take up the amount of space that a group of radio buttons requires.
- `'pushbutton'` – Push buttons generate an action when activated. Left-click a push button to activate it. The button appears to depress until you release the mouse button. The callback activates when you release the mouse button while still pointing within the push button.
- `'radiobutton'` – Radio buttons are similar to check boxes, but are intended to be mutually exclusive within a group of related radio buttons. When used this way, you can only select one radio button at any given time). To activate a radio button, click and release the mouse button over it. The easiest way to implement mutually exclusive behavior for a set of radio buttons is to place them within a `uibuttongroup`.
- `'slider'` – Sliders accept numeric input within a specific range when you move the “thumb” button along a bar. The location of the thumb indicates a numeric value, assigned to the `Value` property when you release the mouse button. You can set the minimum, maximum, and current values, and step sizes of a slider.

Move the thumb by doing any one of the following:

- Press the mouse button on the thumb, and drag it along the bar.

- Click in the bar or on arrow buttons located at both ends of the bar.
- Click the keyboard arrow keys when the slider is in focus.
- 'text' – Static text boxes display lines of text. You typically use static text to label other controls, provide information to the user, or indicate values associated with a slider. Users cannot change static text interactively. Static text controls do not activate callback routines when clicked.
- 'togglebutton' – Toggle buttons are similar in appearance to push buttons, but they visually indicate their state, either on (pressed down) or off (up). Clicking a toggle button changes its state, and switches its Value property between Min and Max.

## Tips

- To simulate activation on static text by a mouse click, set the text *object's* Enable property to Inactive, and set its ButtonDownFcn callback to perform an action. For example, the following code displays "Text was clicked" in the Command Window when you click on the Click Me! text in the running GUI. (Without the set command, it would do nothing.)

```
h = uicontrol('Style','text','String','Click Me!');
set(h,'Enable','Inactive','ButtonDownFcn',...
 'disp(''Text was clicked'')')
```

- Adding a uicontrol to a figure removes the figure toolbar when the figure Toolbar property is 'auto' (which is the default). To prevent this from happening, set the Toolbar property to 'figure'. You can restore the toolbar by selecting **Figure Toolbar** from the **View** menu regardless of this property setting.
- The uicontrol function accepts property name/property value pairs, structures, and cell arrays as input arguments and optionally returns the handle of the created object. You can also use the set and get functions to set and query property values after creating the control.
- A uicontrol object is a child of a figure, uipanel, or uibuttongroup. Therefore, the uicontrol object does not require an axes to exist when placed in a figure window, uipanel, or uibuttongroup.



- When you pause MATLAB and a uicontrol has focus, pressing a keyboard key does not cause MATLAB to resume. Click anywhere outside a uicontrol and then press any key. For more information, see the `pause` function.

## Examples

Create a figure and an axes to contain a 3-D surface plot.

```
figure
hax = axes('Units','pixels');
surf(peaks)
```

Place a uicontrol object to let users change the colormap with a pop-up menu. Supply a function handle as the object's `Callback` property.

```
uicontrol('Style','popup',...
 'String','jet|hsv|hot|cool|gray',...
 'Position',[20 340 100 50],...
 'Callback',@setmap);
% The popup function handle callback
% is implemented as a local function
```

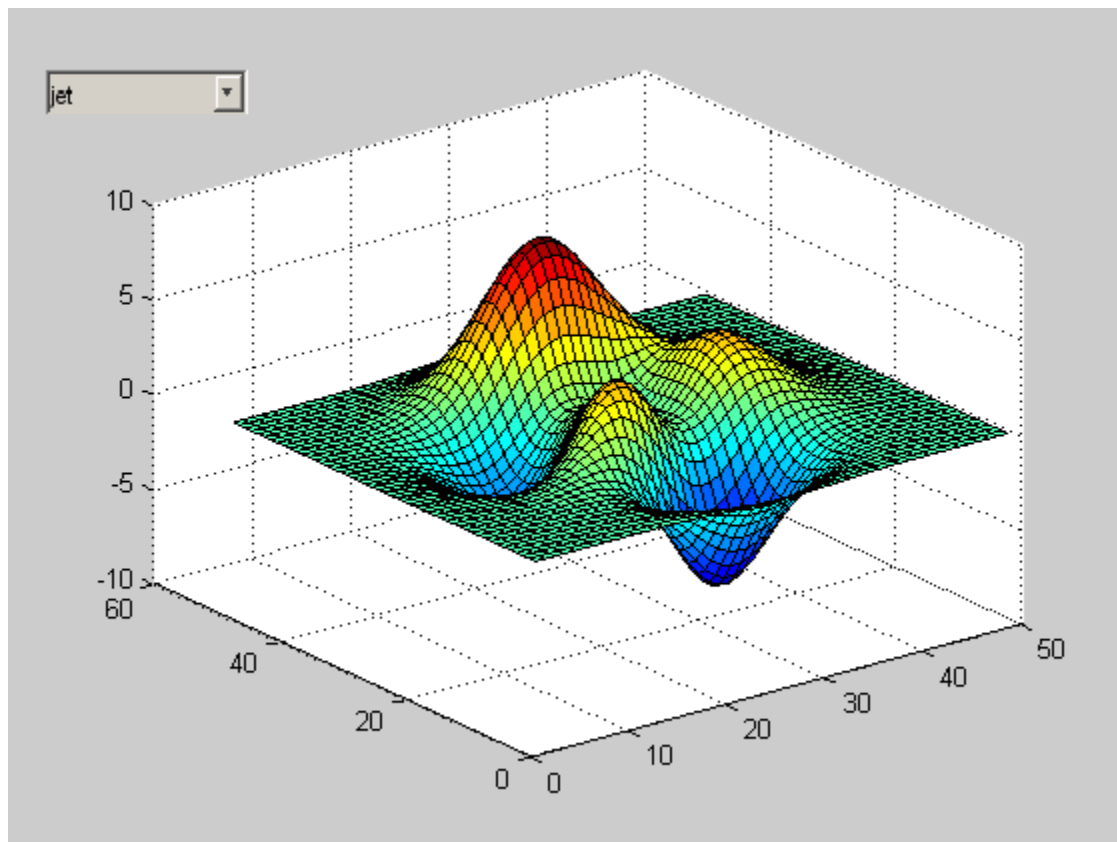

Add a different uicontrol. Create a push button that clears the current axes when pressed. Position the button inside the axes at the lower left. All uicontrols have default units of pixels. In this example, the axes has units of pixels, as well.

```
uicontrol('Style', 'pushbutton', 'String', 'Clear',...
 'Position', [20 20 50 20],...
 'Callback', 'cla');
% The pushbutton string callback
% calls a MATLAB function
```

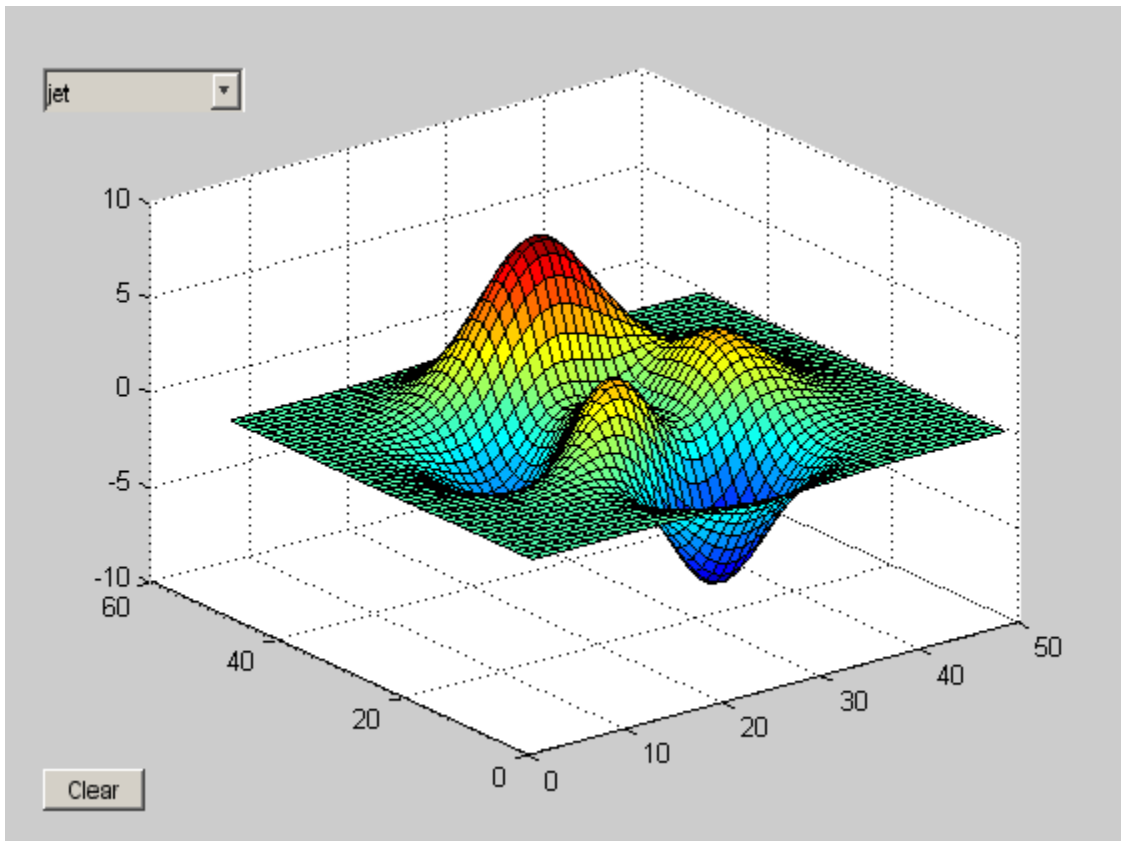

Add a slider uicontrol to control the vertical scaling of the surface object. Position it at the bottom right corner of the figure. Then add a text uicontrol as a label for the slider.

```
uicontrol('Style', 'slider',...
 'Min',1,'Max',50,'Value',41,...
 'Position', [400 20 120 20],...
 'Callback', {@surfzlim,hax});
% Uses cell array function handle callback
```

# uicontrol

```
% Implemented as a local function with an argument

uicontrol('Style','text',...
 'Position',[400 45 120 20],...
 'String','Vertical Exaggeration')
```

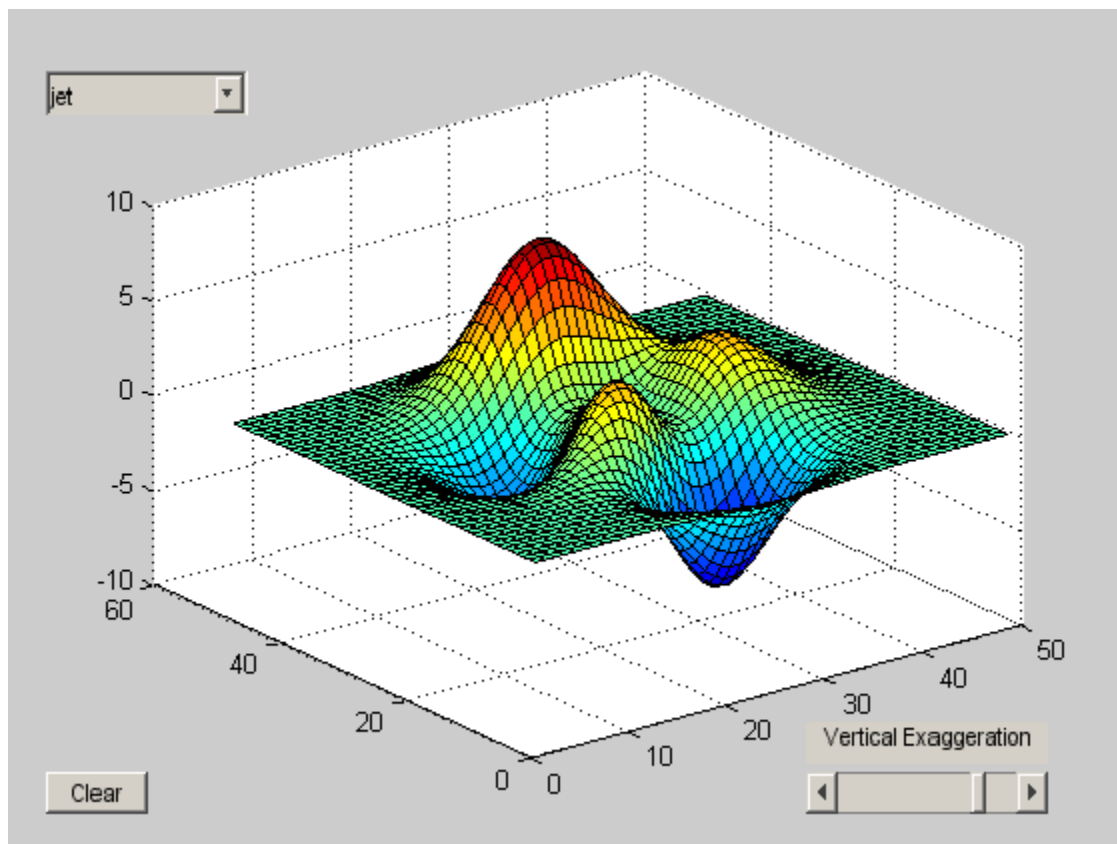

To operate the controls, you need callback functions. The callback for the pop-up menu is a local function called `setmap` that contains the following code.

```
function setmap(hObject,event) %#ok<INUSD>
% Called when user activates popup menu
val = get(hObject,'Value');
if val ==1
 colormap(jet)
elseif val == 2
 colormap(hsv)
elseif val == 3
 colormap(hot)
elseif val == 4
 colormap(cool)
elseif val == 5
 colormap(gray)
end
end
```

The callback for the slider is also a local function in the same file, and contains the following code.

```
function surfzlim(hObject,event,ax) %#ok<INUSL>
% Called to set zlim of surface in figure axes
% when user moves the slider control
val = 51 - get(hObject,'Value');
zlim(ax,[-val val]);
end
```

To use the uicontrols in the example, you need to put all the functions in a MATLAB code file. Copy the following code and paste it into a new file. Save the file as `ex_uicontrol.m` on your search path, and then run it.

```
function ex_uicontrol
% Example code for uicontrol reference page

% Create a figure and an axes to
% contain a 3-D surface plot.
figure
hax = axes('Units','pixels');
```

```
surf(peaks)
% Create a uicontrol object to let users
% change the colormap with a pop-up menu.
% Supply a function handle as the object's
% Callback:
uicontrol('Style', 'popup',...
 'String', 'hsv|hot|cool|gray',...
 'Position', [20 340 100 50],...
 'Callback', @setmap);

% Add a different uicontrol. Create a push button
% that clears the current axes when pressed.
% Position the button inside the axes at the lower
% left. All uicontrols have default units of pixels.
% In this example, the axes does as well.
uicontrol('Style', 'pushbutton', 'String', 'Clear',...
 'Position', [20 20 50 20],...
 'Callback', 'cla');

% Add a slider uicontrol to control the vertical
% scaling of the surface object. Position it
% under the Clear button.
uicontrol('Style', 'slider',...
 'Min',1,'Max',50,'Value',41,...
 'Position', [400 20 120 20],...
 'Callback', {@surfzlim,hax});
% Slider function handle callback
% Implemented as a local function

% Add a text uicontrol to label the slider.
uicontrol('Style','text',...
 'Position',[400 45 120 20],...
 'String','Vertical Exaggeration')
end

function setmap(hObj,event) %#ok<INUSD>
```

```
% Called when user activates popup menu
val = get(hObject,'Value');
if val ==1
 colormap(jet)
elseif val == 2
 colormap(hsv)
elseif val == 3
 colormap(hot)
elseif val == 4
 colormap(cool)
elseif val == 5
 colormap(gray)
end
end

function surfzlim(hObject,event,ax) %#ok<INUSL>
% Called to set zlim of surface in figure axes
% when user moves the slider control
val = 51 - get(hObject,'Value');
zlim(ax,[-val val]);
end
```

**See Also**

[textwrap](#) | [uibbuttongroup](#) | [uimenu](#) | [uipanel](#) | [uipushtool](#) | [uitable](#) | [uitoggletool](#)

**How To**

- [Examples: Programming GUI Components](#)

# Uicontrol Properties

---

## Purpose

Describe user interface control (`uicontrol`) properties

## Modifying Properties

You can set and query graphics object properties in two ways:

- The Property Inspector is an interactive tool that enables you to see and change object property values. The Property inspector is available from GUIDE, or use the `inspect` function at the command line.
- The `set` and `get` commands enable you to set and query the values of properties

To change the default value of properties see “Setting Default Property Values”. You can also set default `uicontrol` properties on the root and figure levels:

```
set(0, 'DefaultUicontrolProperty', PropertyValue...)
set(gcf, 'DefaultUicontrolProperty', PropertyValue...)
```

where *Property* is the name of the `uicontrol` property whose default value you want to set and *PropertyValue* is the value you are specifying as the default. Use `set` and `get` to access `uicontrol` properties.

For information on using these `uicontrols` within GUIDE, the MATLAB GUI development environment, see Programming GUI Components in the MATLAB Creating GUIs documentation.

## Uicontrol Properties

This section lists all properties useful to `uicontrol` objects along with valid values and descriptions of their use. Curly braces `{}` enclose default values.

Property	Purpose
<code>BackgroundColor</code>	Object background color
<code>BeingDeleted</code>	This object is being deleted
<code>BusyAction</code>	Callback routine interruption
<code>ButtonDownFcn</code>	Button-press callback routine



# Uicontrol Properties

<b>Property</b>	<b>Purpose</b>
Callback	Control action
CData	Truecolor image displayed on the control
Children	Uicontrol objects have no children
CreateFcn	Callback routine executed during object creation
DeleteFcn	Callback routine executed during object deletion
Enable	Enable or disable the uicontrol
Extent	position rectangle (read only)
FontAngle	Character slant
FontName	Font family
FontSize	Font size
FontUnits	Font size units
FontWeight	Weight of text characters
ForegroundColor	Color of text
HandleVisibility	Whether handle is accessible from command line and GUIs
HorizontalAlignment	Alignment of label string
Interruptible	Callback routine interruption mode
KeyPressFcn	Key press callback routine
ListboxTop	Index of top-most string displayed in list box
Max	Maximum value (depends on uicontrol object)
Min	Minimum value (depends on uicontrol object)
Parent	Uicontrol object's parent

# Uicontrol Properties

---

Property	Purpose
Position	Size and location of uicontrol object
SliderStep	Slider step size
String	Uicontrol object label, also list box and pop-up menu items
Style	Type of uicontrol object
Tag	User-specified object identifier
TooltipString	Content of object's tooltip
Type	Class of graphics object
UIContextMenu	Uicontextmenu object associated with the uicontrol
Units	Units to interpret position vector
UserData	User-specified data
Value	Current value of uicontrol object
Visible	Uicontrol visibility

BackgroundColor  
ColorSpec

*Object background color.* The color used to fill the uicontrol rectangle. Specify a color using a three-element RGB vector or one of the MATLAB predefined names. The default color is determined by system settings. See `ColorSpec` for more information on specifying color.

---

**Note** Platform look and feel for a GUI element can override change requests from MATLAB. It is possible your system will not honor a request to change the background color.

---

## BeingDeleted

on | {off} (read-only)

*This object is being deleted.* Mechanism to determine if objects are in the process of being deleted. MATLAB sets the `BeingDeleted` property to `on` when the object's delete function callback is called (see the `DeleteFcn` property). It remains set to `on` while the delete function executes, after which the object no longer exists.

For example, an object's delete function calls other functions that act on a number of different objects. If a function does not need to perform an action on an about-be-deleted object, it can check the object's `BeingDeleted` property before acting.

## BusyAction

cancel | {queue}

### *Callback queuing*

Determines how MATLAB handles the execution of interrupting callbacks.

A *running* callback is the currently executing callback. The *interrupting* callback is the callback that tries to interrupt the *running* callback. The `BusyAction` property of the *interrupting* callback determines how MATLAB handles its execution. When the `BusyAction` property is set to:

- 'queue' — Puts the *interrupting* callback in a queue to be processed after the *running* callback finishes execution.
- 'cancel' — Discards the *interrupting* callback as MATLAB finishes execution.

For information about how the `Interruptible` property of the callback controls whether other callbacks can interrupt the *running* callback, see the `Interruptible` property description.

# Uicontrol Properties

---

## ButtonDownFcn

string or function handle (GUIDE sets this property)

*Button-press callback routine.* A callback routine that can execute when you press a mouse button while the pointer is on or near a uicontrol. Specifically:

- If the uicontrol's `Enable` property is set to `on`, the `ButtonDownFcn` callback executes when you click the right or left mouse button in a 5-pixel border around the uicontrol or when you click the right mouse button on the control itself.
- If the uicontrol's `Enable` property is set to `inactive` or `off`, the `ButtonDownFcn` executes when you click the right or left mouse button in the 5-pixel border or on the control itself.

This is useful for implementing actions to interactively modify control object properties, such as size and position, when they are clicked on (using `selectmoveresize`, for example).

Define this routine as a string that is a valid MATLAB expression or the name of a code file. The expression executes in the MATLAB workspace.

To add a `ButtonDownFcn` callback in GUIDE, select **View Callbacks** from the Layout Editor **View** menu, then select `ButtonDownFcn`. GUIDE sets this property to the appropriate string and adds the callback to the code file the next time you save the GUI. Alternatively, you can set this property to the string `%automatic`. The next time you save the GUI, GUIDE sets this property to the appropriate string and adds the callback to the code file.

Use the `Callback` property to specify the callback routine that executes when you activate the enabled uicontrol (e.g., click a push button).

## Callback

string or function handle (GUIDE sets this property)

*Control action.* A function that executes whenever you activate the uicontrol object (e.g., when you click on a push button or move a slider). Define this function as a string that is a valid MATLAB expression or the name of a code file. The expression executes in the MATLAB workspace.

See “Callbacks for Specific Components” for examples of callback functions for each style of component.

## CData

matrix

*Truecolor image displayed on control.* A three-dimensional matrix of RGB values that defines a truecolor image displayed on a control, which must be a **push button** or **toggle button**. Each value must be between 0.0 and 1.0. Setting CData on a **radio button** or **checkbox** will replace the default CData on these controls. The control will continue to work as expected, but its state is not reflected by its appearance when clicked.

For **push buttons** and **toggle buttons**, CData overlaps the String. In the case of **radio buttons** and **checkboxes**, CData takes precedence over String and, depending on its size, it can displace the text.

Setting CData to [] restores the default CData for **radio buttons** and **checkboxes**.

## Children

matrix

The empty matrix; uicontrol objects have no children.

## Clipping

{on} | off

# Uicontrol Properties

---

This property has no effect on `uicontrol` objects.

`CreateFcn`  
string or function handle

*Callback routine executed during object creation.* The specified function executes when MATLAB creates a `uicontrol` object. MATLAB sets all property values for the `uicontrol` before executing the `CreateFcn` callback so these values are available to the callback. Within the function, use `gcbo` to get the handle of the `uicontrol` being created.

Setting this property on an existing `uicontrol` object has no effect.

You can define a default `CreateFcn` callback for all new `uicontrol`s. This default applies unless you override it by specifying a different `CreateFcn` callback when you call `uicontrol`. For example, the code

```
set(0, 'DefaultUicontrolCreateFcn', 'set(gcbo, ...
 'BackgroundColor', 'white')')
```

creates a default `CreateFcn` callback that runs whenever you create a new `uicontrol`. It sets the default background color of all new `uicontrol`s.

To override this default and create a `uicontrol` whose `BackgroundColor` is set to a different value, call `uicontrol` with code similar to

```
hpt = uicontrol(..., 'CreateFcn', 'set(gcbo, ...
 'BackgroundColor', 'blue')')
```

---

**Note** To override a default `CreateFcn` callback you must provide a new callback and not just provide different values for the specified properties. This is because the `CreateFcn` callback runs after the property values are set, and can override property values you have set explicitly in the `uicontrol` call. In the example above, if instead of redefining the `CreateFcn` property for this `uicontrol`, you had explicitly set `BackgroundColor` to `blue`, the default `CreateFcn` callback would have set `BackgroundColor` back to the default, i.e., `white`.

---

Do not call `copyobj` or `textwrap` (which calls `copyobj`) inside a `CreateFcn`. The act of copying the `uicontrol` object fires the `CreateFcn` repeatedly, which raises a series of error messages after exceeding the root object's `RecursionLimit` property.

See “Function Handle Callbacks” for information on how to use function handles to define a callback function.

## DeleteFcn

string or function handle

*Delete uicontrol callback routine.* A callback routine that executes when you delete the `uicontrol` object (e.g., when you issue a `delete` command or clear the figure containing the `uicontrol`). MATLAB executes the routine before destroying the object's properties so these values are available to the callback routine.

The handle of the object whose `DeleteFcn` is being executed is accessible only through the root `CallbackObject` property, which you can query using `gcbo`.

See “Function Handle Callbacks” for information on how to use function handles to define a callback function.

## Enable

{on} | inactive | off

# Uicontrol Properties

---

*Enable or disable the uicontrol.* This property controls how uicontrols respond to mouse button clicks, including which callback routines execute.

- **on** – The uicontrol is operational (the default).
- **inactive** – The uicontrol is not operational, but looks the same as when **Enable** is on.
- **off** – The uicontrol is not operational and its image (set by the **Cdata** property) is grayed out.

When you left-click on a uicontrol whose **Enable** property is on, MATLAB performs these actions in this order:

- 1** Sets the figure **SelectionType** property.
- 2** Executes the uicontrol **Callback** routine, if any. (Static text components do not use callbacks.)
- 3** Does *not* set the figure **CurrentPoint** property and does *not* execute either the uicontrol **ButtonDownFcn** or the figure **WindowButtonDownFcn** callback.

Single-clicking or double-clicking an enabled uicontrol with the left mouse button sets the figure **SelectionType** property to **normal**, unless the uicontrol **Style** is **listbox**. For list boxes, double-clicking sets the figure **SelectionType** property to **open** on the second of the two clicks, enabling the list box callback to detect a set of multiple choices.

When you left-click on a uicontrol whose **Enable** property is **off** or **inactive**, or when you right-click a uicontrol whose **Enable** property has any value, MATLAB performs these actions in this order:

- 1** Sets the figure **SelectionType** property.
- 2** Sets the figure **CurrentPoint** property.
- 3** Executes the figure **WindowButtonDownFcn** callback, if provided.



**4** Executes the uicontrol `ButtonDownFcn` callback, if provided.

## Extent

position rectangle (read only)

*Size of uicontrol character string.* A four-element vector that defines the size and position of the character string used to label the uicontrol. It has the form:

```
[0,0,width,height]
```

The first two elements are always zero. `width` and `height` are the dimensions of the rectangle. All measurements are in units specified by the `Units` property.

Since the `Extent` property is defined in the same units as the uicontrol itself, you can use this property to determine proper sizing for the uicontrol with regard to its label. Do this by

- Defining the `String` property and selecting the font using the relevant properties.
- Getting the value of the `Extent` property.
- Defining the `width` and `height` of the `Position` property to be somewhat larger than the `width` and `height` of the `Extent`.

For multiline strings, the `Extent` rectangle encompasses all the lines of text. For single line strings, the `height` element of the `Extent` property returned always indicates the height of a single line, and its `width` element always indicates the width of the longest line, even if the string wraps when displayed on the control. Edit boxes are considered multiline if `Max - Min > 1`.

## FontAngle

```
{normal} | italic | oblique
```

*Character slant.* MATLAB uses this property to select a font from those available on your particular system. Setting this property

# Uicontrol Properties

---

to *italic* or *oblique* selects a slanted version of the font, when it is available on your system.

FontName  
string

*Font family.* The name of the font in which to display the String. To display and print properly, this must be a font that your system supports. The default font is system dependent.

---

**Note** MATLAB GUIs do not support the Marlett and Symbol font families.

---

To use a fixed-width font that looks good in any locale (and displays properly in Japan, where multibyte character sets are used), set FontName to the string FixedWidth (this string value is case sensitive):

```
set(uicontrol_handle, 'FontName', 'FixedWidth')
```

This parameter value eliminates the need to hard code the name of a fixed-width font, which may not display text properly on systems that do not use ASCII character encoding (such as in Japan). A properly written MATLAB application that needs to use a fixed-width font should set FontName to FixedWidth and rely on the root FixedWidthFontName property to be set correctly in the end user's environment.

End users can adapt a MATLAB application to different locales or personal environments by setting the root FixedWidthFontName property to the appropriate value for that locale from startup.m. Setting the root FixedWidthFontName property causes an immediate update of the display to use the new font.

---

**Tip** To determine what fonts exist on your system (which can differ from the GUI user's system), use the `uisetfont` GUI to select a font and return its name and other characteristics in a MATLAB structure.

---

**FontSize**  
size in `FontUnits`

*Font size.* A number specifying the size of the font in which to display the `String`, in units determined by the `FontUnits` property. The default point size is system dependent.

**FontUnits**  
{points} | normalized | inches |  
centimeters | pixels

*Font size units.* This property determines the units used by the `FontSize` property. Normalized units interpret `FontSize` as a fraction of the height of the uicontrol. When you resize the uicontrol, MATLAB modifies the screen `FontSize` accordingly. pixels, inches, centimeters, and points are absolute units (1 point =  $\frac{1}{72}$  inch).

**FontWeight**  
light | {normal} | demi | bold

*Weight of text characters.* MATLAB uses this property to select a font from those available on your particular system. Setting this property to `bold` causes MATLAB to use a bold version of the font, when it is available on your system.

**ForegroundColor**  
`ColorSpec`

*Color of text.* This property determines the color of the text defined for the `String` property (the uicontrol label). Specify a

# Uicontrol Properties

---

color using a three-element RGB vector or one of the MATLAB predefined names. The default text color is black. See `ColorSpec` for more information on specifying color.

---

**Note** If you change the `ForegroundColor` for a uicontrol listbox, MATLAB uses that color for all listbox items *except* selected listbox items. For selected items MATLAB uses a color that ensures good contrast between the text of selected items and the color that indicates a selection.

---

## HandleVisibility

{on} | callback | off

*Control access to object's handle.* This property determines when an object's handle is visible in its parent's list of children. When a handle is not visible in its parent's list of children, it is not returned by functions that obtain handles by searching the object hierarchy or querying handle properties. This includes `get`, `findobj`, `gca`, `gcf`, `gco`, `newplot`, `cla`, `clf`, and `close`. Neither is the handle visible in the parent figure's `CurrentObject` property. Handles that are hidden are still valid. If you know an object's handle, you can `set` and `get` its properties, and pass it to any function that operates on handles.

- Handles are always visible when `HandleVisibility` is `on`.
- Setting `HandleVisibility` to `callback` causes handles to be visible from within callback routines or functions invoked by callback routines, but not from within functions invoked from the command line. This provides a means to protect GUIs from command-line users, while allowing callback routines to have complete access to object handles.
- Setting `HandleVisibility` to `off` makes handles invisible at all times. This may be necessary when a callback routine invokes a function that might potentially damage the GUI

(such as evaluating a user-typed string), and so temporarily hides its own handles during the execution of that function.

You can set the root `ShowHiddenHandles` property to on to make all handles visible, regardless of their `HandleVisibility` settings. This does not affect the values of the `HandleVisibility` properties.

---

**Note** Radio buttons and toggle buttons that are managed by a `uibuttongroup` should not be accessed outside the button group. Set the `HandleVisibility` of such radio buttons and toggle buttons to off to prevent inadvertent access.

---

## HitTest

{on} | off

*Selectable by mouse click.* This property has no effect on uicontrol objects.

---

**Note** Use of the uicontrol `HitTest` property is not recommended. This property might be removed in a future release.

---

## HorizontalAlignment

left | {center} | right

*Horizontal alignment of label string.* This property determines the justification of the text defined for the `String` property (the uicontrol label):

- `left` — Text is left justified with respect to the uicontrol.
- `center` — Text is centered with respect to the uicontrol.

# Uicontrol Properties

---

- `right` — Text is right justified with respect to the uicontrol.

The contents of `edit` and `text` uicontrols are always vertically aligned to the top of the rectangle.

---

**Note** On Microsoft Windows systems, although this property can be specified on all uicontrols, it affects only `edit` and `text` uicontrols.

---

## Interruptible

`off` | `{on}`

### *Callback routine interruption*

Controls whether MATLAB can interrupt an object's callback function when subsequent callbacks attempt to interrupt it.

For user interface objects, the `Interruptible` property affects the callbacks for these properties only:

- `ButtonDownFcn`
- `KeyPressFcn`
- `KeyReleaseFcn`
- `WindowButtonDownFcn`
- `WindowButtonMotionFcn`
- `WindowButtonUpFcn`
- `WindowKeyPressFcn`
- `WindowKeyReleaseFcn`
- `WindowScrollWheelFcn`

A *running* callback is the currently executing callback. The *interrupting* callback is the callback that tries to interrupt the

*running* callback. MATLAB handles both callbacks based on the `Interruptible` property of the object of the *running* callback.

When the `Interruptible` property is set to:

- 'off', MATLAB finishes execution of the *running* callback without any interruptions
- 'on', these conditions apply:
  - If there is a `drawnow`, `figure`, `getframe`, `waitfor`, or `pause` command in the *running* callback, then MATLAB executes the *interrupting* callbacks which are already in the queue and returns to finish execution of the current callback.
  - If one of the above functions is not in the *running* callback, then MATLAB finishes execution of the current callback without any interruption.

The `BusyAction` property of the object of interrupting callback determines whether the callback should be ignored or should be put in the queue.

Setting the `Interruptible` property to `on` (default), allows a callback from other user interface objects to interrupt callback functions originating from this object.

---

**Note** MATLAB does not save the state of properties or the display when an interruption occurs. For example, the handle returned by the `gca` or `gcf` command may be changed as another callback is executed.

---

After the function that interrupts a callback completes, the callback resumes execution where it halted when interrupted. For more information, see “Control Callback Execution and Interruption”.

# Uicontrol Properties

---

---

**Note** If the interrupting callback is a `DeleteFcn` or `CreateFcn` callback, or a figure's `CloseRequest` or `ResizeFcn` callback, it interrupts an executing callback regardless of the value of that object's `Interruptible` property. The interrupting callback starts execution at the next `drawnow`, `figure`, `getframe`, `pause`, or `waitfor` statement. An object's `ButtonDownFcn` or `Callback` routine is processed according to the rules described previously in this section.

---

## `KeyPressFcn`

string or function handle

*Key press callback function.* A callback routine invoked by a key press when the callback's uicontrol object has focus. Focus is denoted by a border or a dotted border, respectively, in UNIX and Microsoft Windows. If no uicontrol has focus, the figure's key press callback function, if any, is invoked. `KeyPressFcn` can be a function handle, the name of a code file, or any legal MATLAB expression.

If the specified value is the name of a code file, the callback routine can query the figure's `CurrentCharacter` property to determine what particular key was pressed and thereby limit the callback execution to specific keys.

If the specified value is a function handle, the callback routine can retrieve information about the key that was pressed from its event data structure argument.



Event Data Structure Field	Description	Examples:			
		a	=	Shift	Shift/a
Character	Character interpretation of the key that was pressed.	'a'	'='	' '	'A'
Modifier	Current modifier, such as 'control', or an empty cell array if there is no modifier	{1x0 cell}	{1x0 cell}	{'shift'}	{'shift'}
Key	Name of the key that was pressed.	'a'	'equal'	'shift'	'a'

See “Function Handle Callbacks” for information on how to use function handles to define the callback function.

**ListboxTop**  
scalar

*Index of top-most string displayed in list box.* This property applies only to the `listbox` style of uicontrol. It specifies which string appears in the top-most position in a list box that is not large enough to display all list entries. `ListboxTop` is an index into the array of strings defined by the `String` property and must have a value between 1 and the number of strings. Noninteger values are fixed to the next lowest integer.

**Max**  
scalar

*Maximum value.* This property specifies the largest value allowed for the `Value` property. Different styles of uicontrols interpret `Max` differently:

- Check boxes – `Max` is the setting of the `Value` property while the check box is selected.
- Editable text – The `Value` property does not apply. If `Max - Min > 1`, then editable text boxes accept multiline input. If `Max - Min`

# Uicontrol Properties

---

$\leq 1$ , then editable text boxes accept only single line input. The absolute values of `Max` and `Min` have no effect on the number of lines an edit box can contain; a multiline edit box can contain any number of lines.

- List boxes – If  $\text{Max} - \text{Min} > 1$ , then list boxes allow multiple item selection. If  $\text{Max} - \text{Min} \leq 1$ , then list boxes do not allow multiple item selection. When they do, `Value` can be a vector of indices.
- Radio buttons – `Max` is the setting of the `Value` property when the radio button is selected.
- Sliders – `Max` is the maximum slider value and must be greater than the `Min` property. The default is 1.
- Toggle buttons – `Max` is the value of the `Value` property when the toggle button is selected. The default is 1.
- Pop-up menus, push buttons, and static text do not use the `Max` property.

`Min`

scalar

*Minimum value.* This property specifies the smallest value allowed for the `Value` property. Different styles of uicontrols interpret `Min` differently:

- Check boxes – `Min` is the setting of the `Value` property while the check box is not selected.
- Editable text – The `Value` property does not apply. If  $\text{Max} - \text{Min} > 1$ , then editable text boxes accept multiline input. If  $\text{Max} - \text{Min} \leq 1$ , then editable text boxes accept only single line input. The absolute values of `Max` and `Min` have no effect on the number of lines an edit box can contain; a multiline edit box can contain any number of lines.
- List boxes – If  $\text{Max} - \text{Min} > 1$ , then list boxes allow multiple item selection. If  $\text{Max} - \text{Min} \leq 1$ , then list boxes allow only single item selection. When they do, `Value` can be a vector of indices.

- Radio buttons – Min is the setting of the Value property when the radio button is not selected.
- Sliders – Min is the minimum slider value and must be less than Max. The default is 0.
- Toggle buttons – Min is the value of the Value property when the toggle button is not selected. The default is 0.
- Pop-up menus, push buttons, and static text do not use the Min property.

## Parent

handle

*Uicontrol parent.* The handle of the uicontrol's parent object. You can move a uicontrol object to another figure, uipanel, or uibuttongroup by setting this property to the handle of the new parent.

## Position

position rectangle

*Size and location of uicontrol.* The rectangle defined by this property specifies the size and location of the control within the parent figure window, uipanel, or uibuttongroup. Specify Position as

```
[left bottom width height]
```

left and bottom are the distance from the lower-left corner of the parent object to the lower-left corner of the uicontrol object. width and height are the dimensions of the uicontrol rectangle. All measurements are in units specified by the Units property.

On Microsoft Windows systems, the height of pop-up menus is automatically determined by the size of the font. The value you specify for the height of the Position property has no effect.

# Uicontrol Properties

---

The width and height values determine the orientation of sliders. If width is greater than height, then the slider is oriented horizontally. If height is greater than width, then the slider is oriented vertically.

---

**Note** The height of a pop-up menu is determined by the font size. The height you set in the position vector is ignored. The height element of the position vector is not changed.

On Mac platforms, the height of a horizontal slider is constrained. If the height you set in the position vector exceeds this constraint, the displayed height of the slider is the maximum allowed. The height element of the position vector is not changed.

---

## Selected

on | {off}

*Is object selected.* When this property is on, MATLAB displays selection handles if the SelectionHighlight property is also on. You can, for example, define the ButtonDownFcn to set this property, allowing users to select the object with the mouse.

---

**Note** Use of the uicontrol Selected property is not recommended. This property might be removed in a future release.

---

## SelectionHighlight

{on} | off

*Object highlight when selected.* When the Selected property is on, MATLAB indicates the selected state by drawing four edge handles and four corner handles. When SelectionHighlight is off, MATLAB does not draw the handles.

---

**Note** Use of the uicontrol `SelectionHighlight` property is not recommended. This property might be removed in a future release.

---

## SliderStep

[minor\_step major\_step]

*Slider step size*, a two-element vector of positive values that indicates the size of the major and minor steps as a percent change in slider value. Both steps should be greater than  $1e-6$ , and `minor_step` should be less than or equal to `major_step`. The slider `Value` changes up or down by `minor_step` when you click the arrow button, and up or down by `major_step` when you click the slider trough, also called the channel.

The actual step size is a function of the specified `SliderStep` and the total slider range (`Max - Min`). The default, `[0.01 0.10]`, provides a 1 percent change for clicks on the arrow button and a 10 percent change for clicks in the trough.

For example, if you create the following slider,

```
uicontrol('Style','slider','Min',1,'Max',7,...
 'Value',2,'SliderStep',[0.1 0.6])
```

clicking an arrow button moves the thumb indicator toward it by `minor_step*(max-min)`:

```
0.1*(7-1)
ans =
 0.6000
```

Clicking the trough moves the thumb indicator toward the mouse pointer by `major_step*(max-min)`:

```
0.6*(7-1)
```

# Uicontrol Properties

---

```
ans =
 3.6000
```

If clicking moves the slider to a value outside the range, the thumb indicator moves only to the Max or Min value.

As `major_step` increases, the slider thumb indicator grows longer. When `major_step` is 1, the thumb is half as long as the trough. When `major_step` is greater than 1, the thumb continues to grow, slowly approaching the full length of the trough.

See also the `Max`, `Min`, and `Value` properties.

**String**  
string

*Uicontrol label, list box items, pop-up menu choices.*

**For check boxes, editable text, push buttons, radio buttons, static text, and toggle buttons**, the text displayed on the object. For list boxes and pop-up menus, the set of entries or items displayed in the object.

---

**Note** If you specify a numerical value for `String`, MATLAB converts it to `char` but the result may not be what you expect. If you have numerical data, you should first convert it to a string, e.g., using `num2str`, before assigning it to the `String` property.

---

**For uicontrol objects that display only one line of text** (check box, push button, radio button, toggle button), if the string value is specified as a cell array of strings or padded string matrix, only the first string of a cell array or of a padded string matrix is displayed; the rest are ignored. Vertical slash (`'\'`) characters are not interpreted as line breaks and instead show up in the text displayed in the uicontrol.

For **multiple line editable text or static text controls**, line breaks occur between each row of the string matrix, and each cell of a cell array of strings. Vertical slash (|) characters and \n characters are not interpreted as line breaks, and instead show up in the text displayed in the uicontrol. Text in edit text and static text boxes is always vertically top-aligned. For **editable text**, the String property value is set to the string entered by the user when the control loses focus. The String property for **static text** can only be set programmatically (or when authoring a GUI in GUIDE).

To place **multiple items on a list box or pop-up menu**, you can specify the items in any of the formats shown in the following table.

String Property Format	Example
Cell array of strings	{'one' 'two' 'three'}
Padded string column matrix	['one ' '; 'two ' '; 'three' ]
String vector using vertical slash ( ) as a line separator	['one two three' ]

If you specify a component width that is too small to accommodate one or more of the specified strings, MATLAB truncates those strings with an ellipsis. Use the Value property to set the index of the initial item selected.

For **check boxes, push buttons, radio buttons, toggle buttons**, and the selected item in **popup menus**, when the specified text is clipped because it is too long for the uicontrol, an ellipsis (...) is appended to the text in the active GUI to indicate that it has been clipped.

# Uicontrol Properties

---

For **push buttons** and **toggle buttons**, CData overlaps the String. In the case of **radio buttons** and **checkboxes**, CData takes precedence over String and, depending on its size, can displace the text.

---

**Reserved Words** There are three reserved words: `default`, `remove`, `factory` (case sensitive). If you want to use one of these reserved words in the String property, you must precede it with a backslash (`'\'`) character. For example,

```
h = uicontrol('Style','edit','String','\default');
```

---

## Style

{pushbutton} | togglebutton | radiobutton | checkbox |  
edit | text | slider | frame | listbox | popupmenu

*Style of uicontrol object to create.* The Style property specifies the kind of uicontrol to create. See the uicontrol Description section for information on each type.

## Tag

string (GUIDE sets this property)

*User-specified object label.* The Tag property provides a means to identify graphics objects with a user-specified label. This is particularly useful when constructing interactive graphics programs that would otherwise need to define object handles as global variables or pass them as arguments between callback routines. You can define Tag as any string.

## TooltipString

string

*Content of tooltip for object.* The TooltipString property specifies the text of the tooltip associated with the uicontrol. When the



user moves the mouse pointer over the control and leaves it there, the tooltip is displayed.

To create a tooltip that has more than one line of text, use `sprintf` to generate a string containing newline (`\n`) characters and then set the `TooltipString` to that value. For example:

```
h = uicontrol('Style','pushbutton');
s = sprintf('Button tooltip line 1\nButton tooltip line 2');
set(h,'TooltipString',s)
```

## Type

string (read only)

*Class of graphics object.* For `uicontrol` objects, `Type` is always the string `'uicontrol'`.

## UIContextMenu

handle

*Associate a context menu with uicontrol.* Assign this property the handle of a `uicontextmenu` object. MATLAB displays the context menu whenever you right-click over the `uicontrol`. Use the `uicontextmenu` function to create the context menu.

## Units

{pixels} | normalized | inches | centimeters | points | characters (GUIDE default: normalized)

*Units of measurement.* MATLAB uses these units to interpret the `Extent` and `Position` properties. All units are measured from the lower-left corner of the parent object.

- Normalized units map the lower-left corner of the parent object to (0,0) and the upper-right corner to (1.0,1.0).
- pixels, inches, centimeters, and points are absolute units (1 point = 1/72 inch).

# Uicontrol Properties

---

- Character units are characters using the default system font; the width of one character is the width of the letter x, the height of one character is the distance between the baselines of two lines of text.

If you change the value of `Units`, it is good practice to return it to its default value after completing your computation so as not to affect other functions that assume `Units` is set to the default value.

`UserData`  
matrix

*User-specified data.* Any data you want to associate with the uicontrol object. MATLAB does not use this data, but you can access it using `set` and `get`.

`Value`  
scalar or vector

*Current value of uicontrol.* The uicontrol style determines the possible values this property can have:

- Check boxes set `Value` to `Max` when they are on (when selected) and `Min` when off (not selected).
- List boxes set `Value` to a vector of indices corresponding to the selected list entries, where 1 corresponds to the first item in the list.
- Pop-up menus set `Value` to the index of the item selected, where 1 corresponds to the first item in the menu. The Examples section shows how to use the `Value` property to determine which item has been selected.
- Radio buttons set `Value` to `Max` when they are on (when selected) and `Min` when off (not selected).
- Sliders set `Value` to the number indicated by the slider bar.

- Toggle buttons set `Value` to `Max` when they are down (selected) and `Min` when up (not selected).
- Editable text, push buttons, and static text do not set this property.

Set the `Value` property either interactively with the mouse or through a call to the `set` function. The display reflects changes made to `Value`.

## Visible

{on} | off

*Uicontrol visibility.* By default, all uicontrols are visible. When set to `off`, the uicontrol is not visible, but still exists and you can query and set its properties.

---

**Note** Setting `Visible` to `off` for uicontrols that are not displayed initially in the GUI, can result in faster startup time for the GUI.

---

# uigetdir

---

**Purpose** Open standard dialog box for selecting directory

**Syntax**

```
folder_name = uigetdir
folder_name = uigetdir(start_path)
folder_name = uigetdir(start_path,dialog_title)
```

**Description** `folder_name = uigetdir` displays a modal dialog box enabling you to navigate the folder hierarchy and select a folder or type the name of a folder. If the folder exists, `uigetdir` returns the selected path when you click **OK**. If you type the name of a folder that does not exist, `uigetdir` returns the name of the current folder. If you click **Cancel**, or close the dialog box, `uigetdir` returns 0. On Microsoft Windows platforms, `uigetdir` opens a dialog box in the base folder (the Windows desktop) with the current folder selected.

`folder_name = uigetdir(start_path)` opens a dialog box with the folder specified by `start_path` selected. If `start_path` is a valid path, the dialog box opens in the specified folder. If `start_path` is an empty string ( ' ') or is not a valid path, the dialog box opens in the current folder.

`folder_name = uigetdir(start_path,dialog_title)` opens a dialog box with the specified title. On Windows and UNIX platforms, the string replaces the default caption inside the dialog box for specifying instructions to the user. The default `dialog_title` is **Select folder to Open**.

On Windows platforms, you can click the **New Folder** button to add a new folder to the folder hierarchy displayed. You can also drag and drop existing directories into different folders.

On UNIX platforms, `uigetdir` opens a dialog box in the startup folder (the one you are in when you start MATLAB), with the current directory selected. The `dialog_title` string replaces the default title of the dialog box. The dialog box looks similar to the following figure.

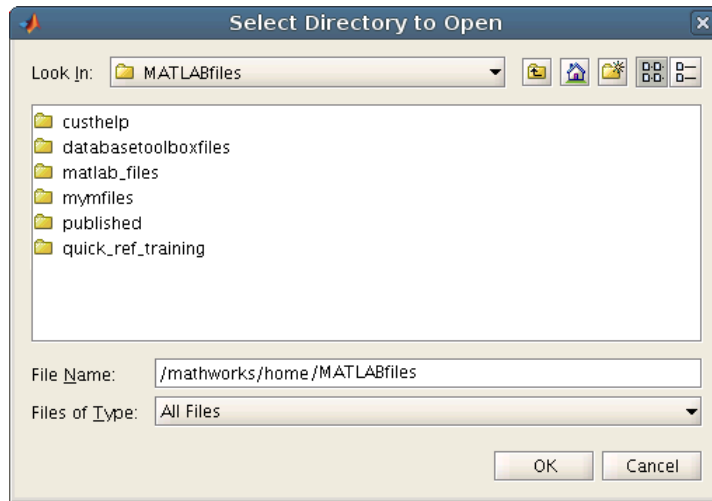

On Mac platforms, `uigetdir` opens a dialog box in the startup folder (the one you are in when you start MATLAB), with the current directory selected. The dialog box looks similar to the following figure.

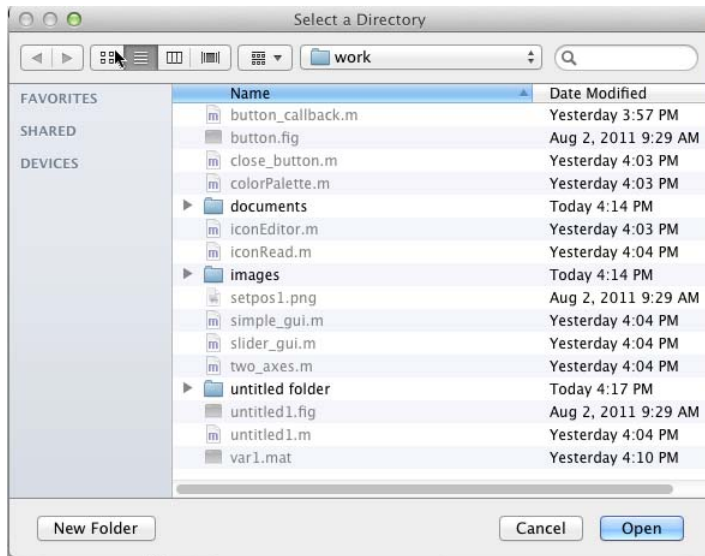

---

**Note** A modal dialog box prevents you from interacting with other MATLAB windows before responding. To block MATLAB program execution as well, use the `uiwait` function. For more information about modal dialog boxes, see `WindowState` in the MATLAB Figure Properties.

---

The `pwd` and `cd` functions return the name of the current folder.

## Examples

The following statement displays directories on the C: drive.

```
dname = uigetdir('C:\');
```

A dialog box such as the following displays (on Windows).

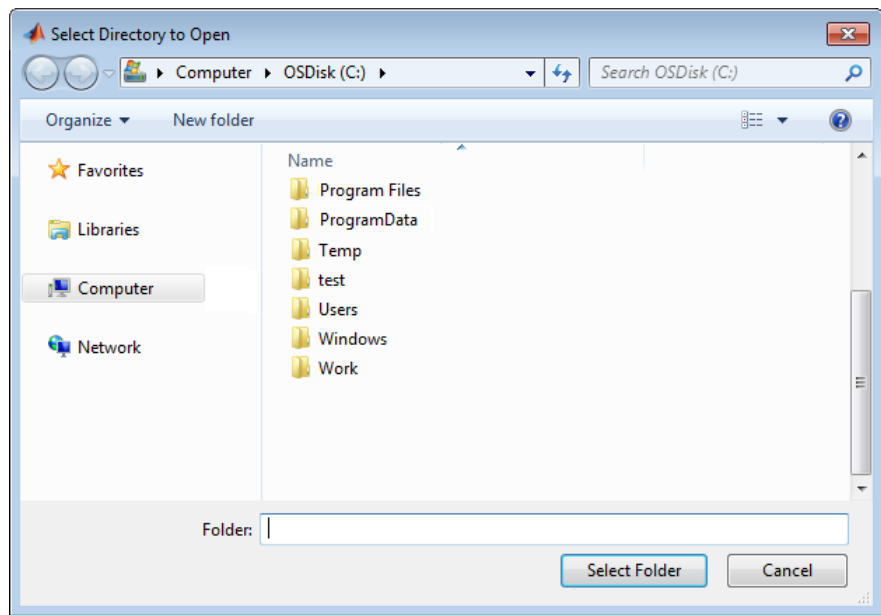

If you double-click the `Program Files` folder, and the `MATLAB` subfolder, and then click **Select Folder**, `uigetdir` returns `C:\Program Files\MATLAB` to `dname`:

The following statement uses `matlabroot` to display the MATLAB root folder in the dialog box:

```
uigetdir(matlabroot, 'MATLAB Root Directory')
```

Assuming that MATLAB is installed on drive `C:\`, selecting the folder `MATLAB\R2012b\notebook\pc` from the dialog box, returns this string:

```
C:\Program Files\MATLAB\R2012b\notebook\pc
```

## See Also

`uigetfile` | `uiputfile`

# uigetfile

---

**Purpose** Open standard dialog box for retrieving files

**Syntax**

```
filename = uigetfile
[FileName,PathName,FilterIndex] = uigetfile(FilterSpec)
[FileName,PathName,FilterIndex] = uigetfile(FilterSpec,DialogTitle)
[FileName,PathName,FilterIndex] = uigetfile(FilterSpec,DialogTitle,
 DefaultName)
[FileName,PathName,FilterIndex] = uigetfile(...,'MultiSelect',
 selectmode)
```

**Description** filename = uigetfile displays a modal dialog box that lists files in the current folder and enables you to select or enter the name of a file. If the file name is valid and the file exists, uigetfile returns the file name as a string when you click **Open**. Otherwise uigetfile displays an appropriate error message, after which control returns to the dialog box. You can then enter another file name or click **Cancel**. If you click **Cancel** or close the dialog window, uigetfile returns 0.

---

**Note** Successful execution of uigetfile does not open a file; it only returns the name of an existing file that you identify.

---

[FileName,PathName,FilterIndex] = uigetfile(FilterSpec) displays only those files with extensions that match FilterSpec. On some platforms uigetfile also displays in gray the files that do not match FilterSpec. The uigetfile function appends 'All Files' to the list of file types. FilterSpec can be a string or a cell array of strings, and can include the \* wildcard.

- If FilterSpec is a file name, that file name displays, selected in the **File name** field. The extension of the file is the default filter.
- FilterSpec can include a path. That path can contain '.', '..', \, '/', or '~'. For example, '../\*.\*m' lists all code files in the folder above the current folder.



- If `FilterSpec` is a folder name, `uigetfile` displays the contents of that folder, the **File name** field is empty, and no filter applies. To specify a folder name, make the last character of `FilterSpec` either `'\'` or `'/'`.
- If `FilterSpec` is a cell array of strings, it can include two columns. The first column contains a list of file extensions. The optional second column contains a corresponding list of descriptions. These descriptions replace standard descriptions in the **Files of type** field. A description cannot be an empty string. The second and third examples illustrate use of a cell array as `FilterSpec`.

If `FilterSpec` is missing or empty, `uigetfile` uses the default list of file types (for example, all MATLAB files).

After you click **Open** and if the file name exists, `uigetfile` returns the name of the file in `FileName` and its path in `PathName`. If you click **Cancel** or close the dialog window, the function sets `FileName` and `PathName` to 0.

`FilterIndex` is the index of the filter selected in the dialog box. Indexing starts at 1. If you click **Cancel** or close the dialog window, the function sets `FilterIndex` to 0.

```
[FileName,PathName,FilterIndex] =
uigetfile(FilterSpec,DialogTitle) displays a dialog box that has
the title DialogTitle. To use the default file types and specify a
dialog title, enter
```

```
uigetfile(' ',DialogTitle)
```

```
[FileName,PathName,FilterIndex] =
uigetfile(FilterSpec,DialogTitle, DefaultName) displays a dialog
box in which the file name specified by DefaultName appears in the
File name field. DefaultName can also be a path or a path/filename. In
this case, uigetfile opens the dialog box in the folder specified by the
path. You can use '.', '..', '\', or '/' in the DefaultName argument.
To specify a folder name, make the last character of DefaultName either
'\ ' or '/ '. If the specified path does not exist, uigetfile opens the
dialog box in the current folder.
```

# uigetfile

---

`[FileName,PathName,FilterIndex] = uigetfile(...,'MultiSelect', selectmode)` opens the dialog box in *multiselect* mode. Valid values for *selectmode* are 'on' and 'off' (the default, which allows single selection only). If 'MultiSelect' is 'on' and you select more than one file in the dialog box, then `FileName` is a cell array of strings. Each array element contains the name of a selected file. File names in the cell array are sorted in the order your platform uses. If you select multiple files, they must be in the same folder, otherwise MATLAB displays a warning dialog box. Be aware that Microsoft Windows libraries can span multiple folders. `PathName` is a string identifying the folder containing the files.

If you include either of the wildcard characters, '\*' or '?', in a file name, `uigetfile` does not respond to clicking **Open**. The dialog box remains open until you cancel it or remove the wildcard characters. This restriction applies to all platforms, even to file systems that permit these characters in file names.

For Windows platforms, the dialog box is the Windows dialog box native to your platform. Depending on your version of Windows, dialogs you see can differ from the figures shown in following examples.

For UNIX platforms, the dialog box is like the one shown in the following figure.

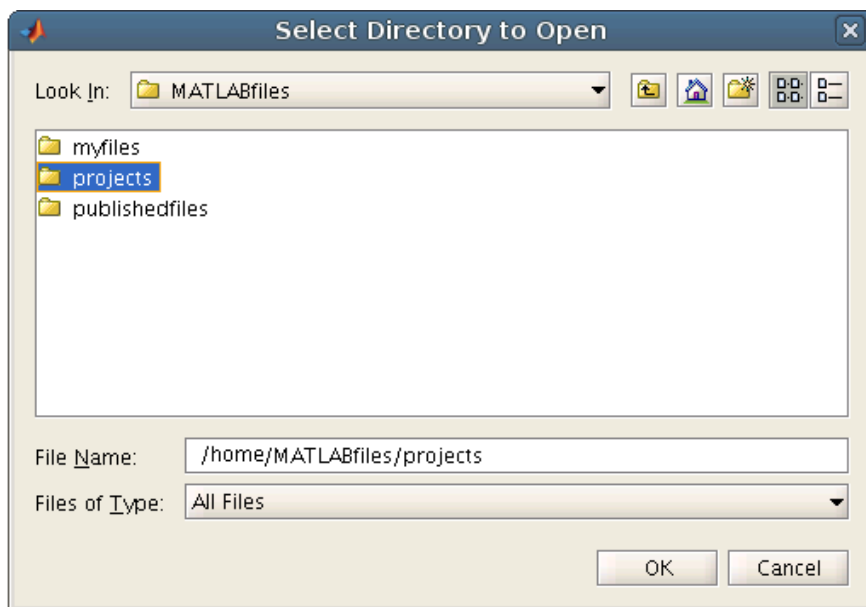

For Mac platforms, the dialog box is like the one shown in the following figure.

# uigetfile

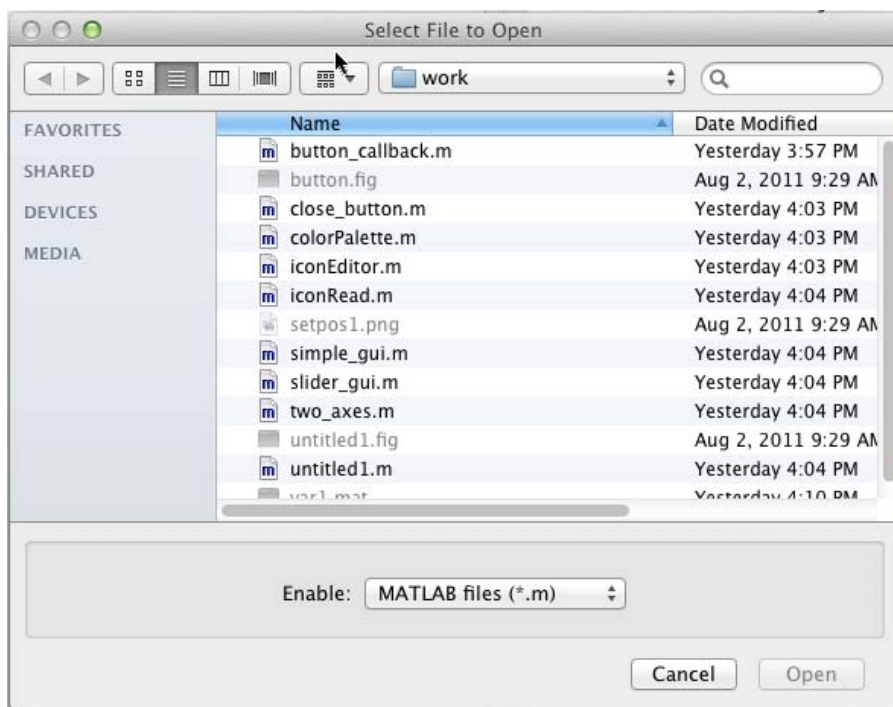

---

**Note** A modal dialog box prevents you from interacting with other windows before responding. To block MATLAB program execution, use the `uiwait` function. For more information about modal dialog boxes, see `WindowState` in the MATLAB Figure Properties.

---

## Examples

The following statement displays a dialog box for retrieving a file. The dialog box lists all MATLAB code files within a selected directory. `uigetfile` returns the name and path of the selected file in `FileName` and `PathName`. `uigetfile` appends `All Files (*.*)` to the file types when `FilterSpec` is a string.

```
[FileName,PathName] = uigetfile('*.m','Select the MATLAB code file');
```

The following figure shows the dialog box with the file type drop-down list open.

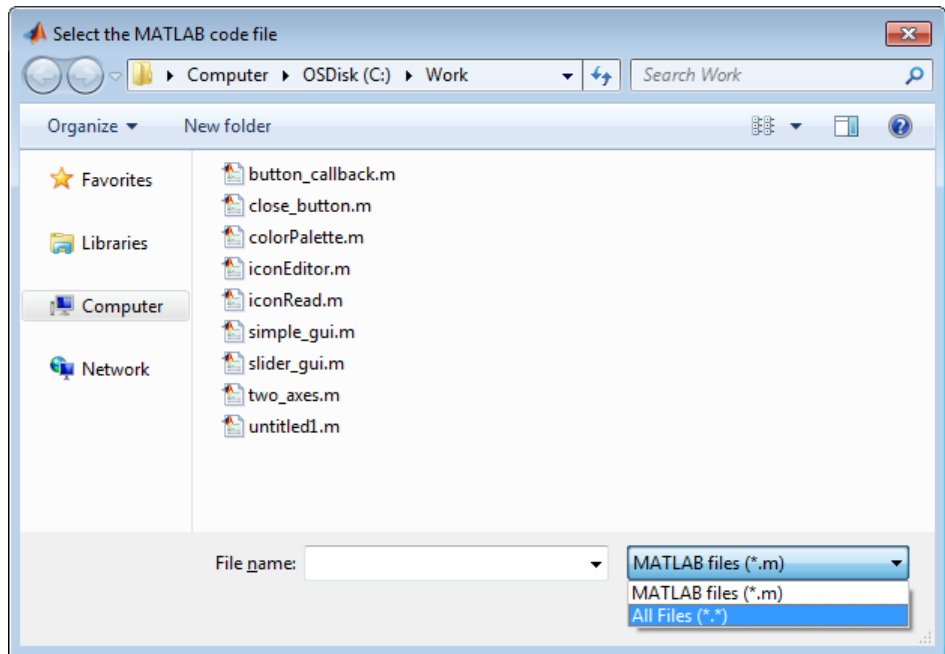

To create a list of file types that appears in the file type drop-down list, separate the file extensions with semicolons, as in the following code. `uigetfile` displays a default description for each known file type, such as "Model files" for Simulink `.slx` and `.mdl` files.

```
[filename, pathname] = ...
 uigetfile({'*.m'; '*.slx'; '*.mat'; '*.*'}, 'File Selector');
```

# uigetfile

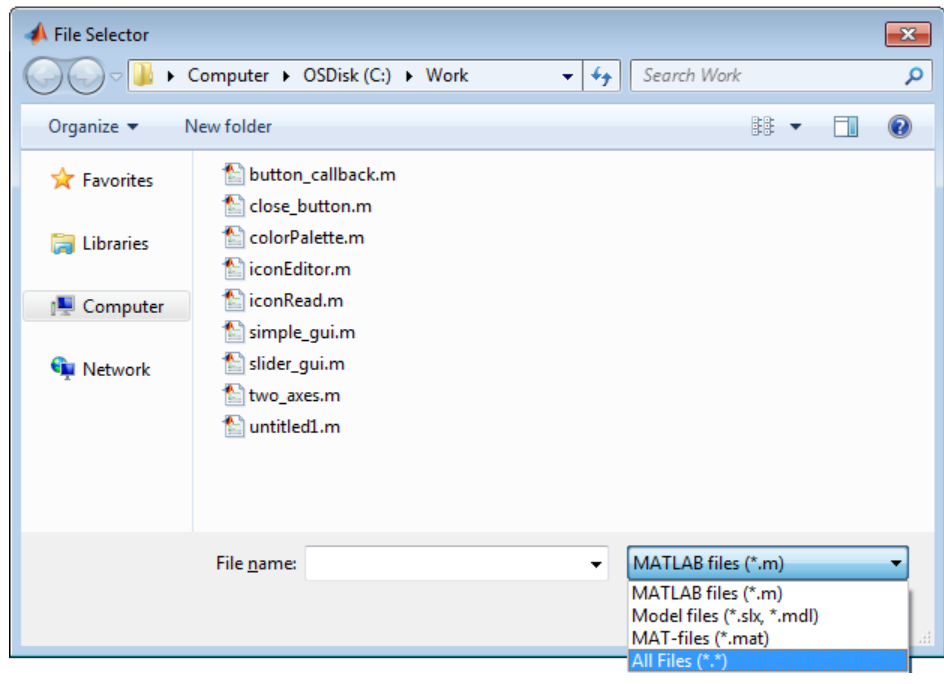

If you want to create a list of file types and give them descriptions that are different from the defaults, use a cell array, as in the following code. This example also associates multiple file types with the 'MATLAB Files' and 'Models' descriptions.

```
[filename, pathname] = uigetfile(...
{'*.m;*.fig;*.mat;*.slx;*.mdl',...
'MATLAB Files (*.m,*.fig,*.mat,*.slx,*.mdl)';
 '*.m', 'Code files (*.m)'; ...
 '*.fig', 'Figures (*.fig)'; ...
 '*.mat', 'MAT-files (*.mat)'; ...
 '*.mdl;*.slx', 'Models (*.slx, *.mdl)'; ...
 '*.*', 'All Files (*.*)'}, ...
'Pick a file');
```

The first column of the cell array contains the file extensions, while the second contains your descriptions of the file types. In this example, the first entry of column one contains several extensions, separated by semicolons, which are all associated with the description 'MATLAB Files (\*.m;\*.fig;\*.mat;\*.mdl)'. The code produces the dialog box shown in the following figure.

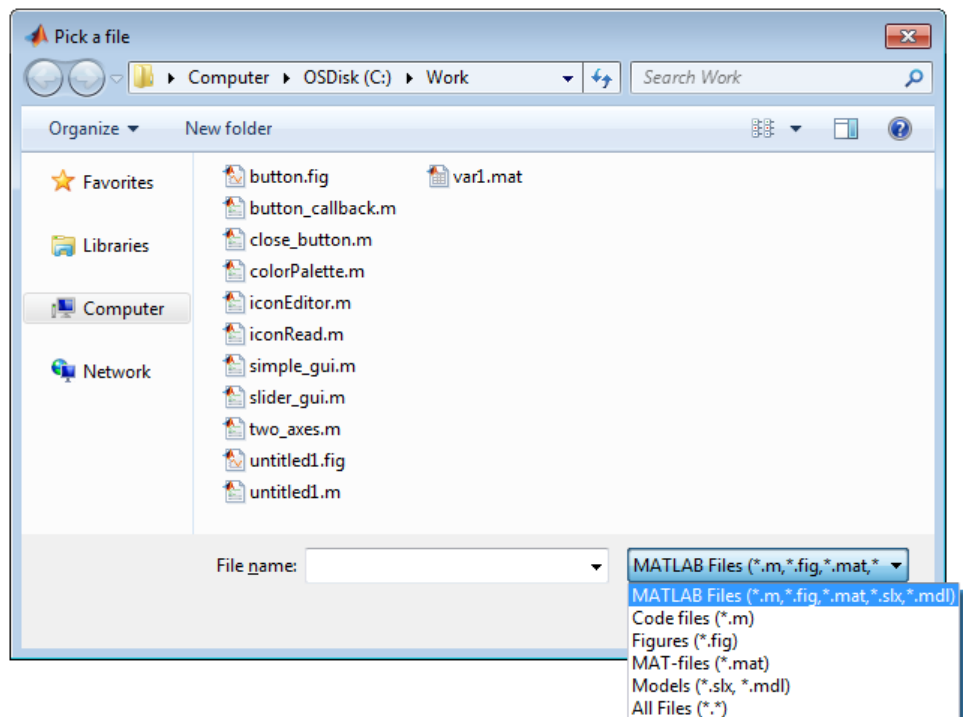

The following code lets you select a file and then displays a message in the Command Window that summarizes the result.

```
[filename, pathname] = uigetfile('*.*', 'Select a MATLAB code file');
if isequal(filename,0)
 disp('User selected Cancel')
```

# uigetfile

---

```
else
 disp(['User selected ', fullfile(pathname, filename)])
end
```

---

This code creates a list of file types and gives them descriptions that are different from the defaults. It also enables multiple-file selection. Select multiple files by holding down the **Shift** or **Ctrl** key and clicking on additional file names.

```
[filename, pathname, filterindex] = uigetfile(...
{ '*.mat', 'MAT-files (*.mat)'; ...
 '*.slx;*.mdl', 'Models (*.slx, *.mdl)'; ...
 .', 'All Files (*.*)'}, ...
'Pick a file', ...
'MultiSelect', 'on');
```



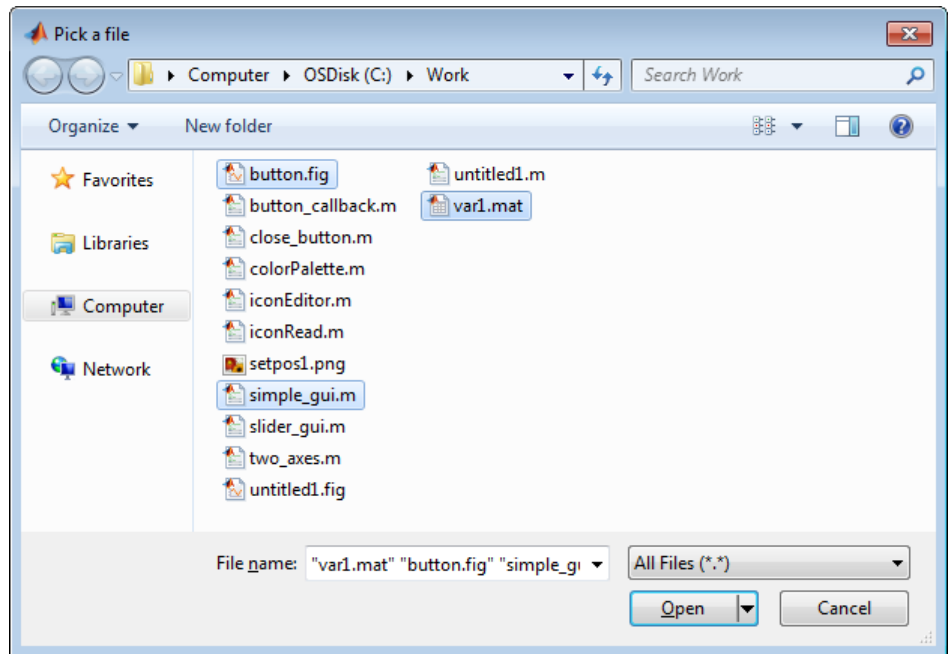

As mentioned previously, `uigetfile` does not open the file or files you select.

You can use the `DefaultName` argument to specify a start path and a default file name for the dialog box.

```
uigetfile({'*.jpg;*.tif;*.png;*.gif','All Image Files';...
 '*.*', 'All Files' }, 'mytitle', ...
 'C:\myfiles\my_examples\gbtools\setpos1.png')
```

# uigetfile

---

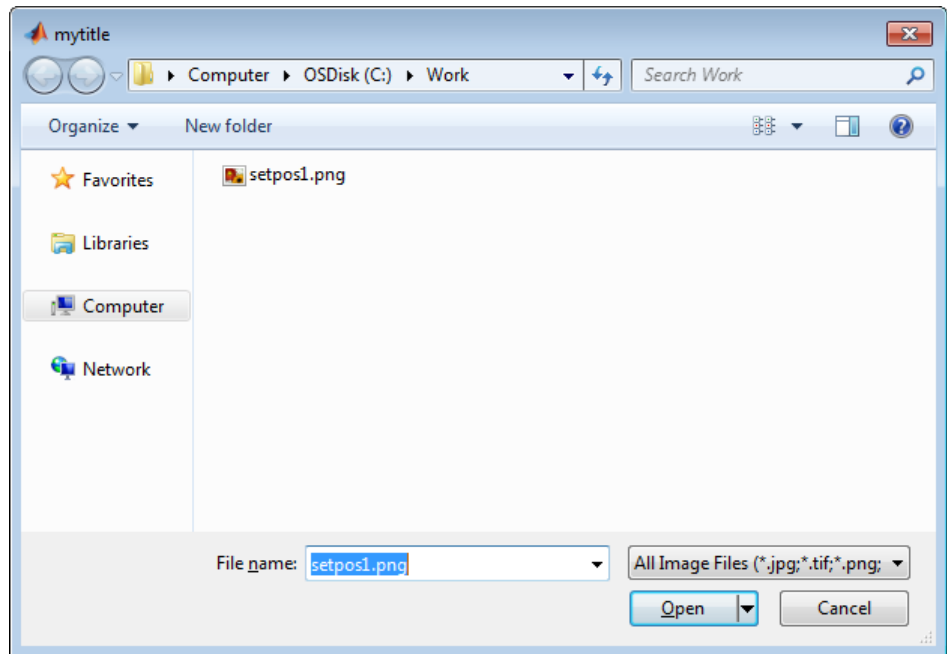

## Alternatives

Use the `dir` function to return a filtered or unfiltered list of files in your current folder or a folder you specify. `dir` also can return file attributes.

## See Also

`uigetdir` | `uiopen` | `uiputfile`

**Purpose** Specify and conditionally open dialog box according to user preference

**Syntax**

```
pref_value =
uigetpref(group,pref,title,question,pref_choices)
[pref_value,dlgshown] = uigetpref(...)
[...] = uigetpref(... 'Name',value)
```

**Description**

`pref_value = uigetpref(group,pref,title,question,pref_choices)` returns one of the strings in `pref_choices` in either of two ways:

- Displays a multiple-choice dialog box that prompts you to answer a question. The dialog box includes a check box with the label **Do not show this dialog again**.
- Retrieves a previous answer from the preferences data base and returns it without displaying a dialog. No dialog is displayed if you previously selected the check box **Do not show this dialog again**.

`[pref_value,dlgshown] = uigetpref(...)` also returns in `dlgshown` whether or not the dialog displayed.

`[...] = uigetpref(... 'Name',value)` specify optional name-value pairs to control how dialogs display.

- Tips**
- You must supply all input arguments up to and including `pref_choices`.
  - `uigetpref` creates specified groups and preferences, if they do not currently exist. To delete a preference group you no longer need, use `rmpref`.
  - The string returned in `pref_value` is a preference name (as specified in `pref`), not its button label (as specified in `pref_choices`).
  - After you select the check box **Do not show this dialog again** and close the dialog box, the dialog box does not display again for the same preference. To reenable dialogs that are being suppressed by preferences, use the command:

# uigetpref

---

```
uigetpref('clearall')
```

Executing `uigetpref` with this command re-enables *all* preference dialogs you have defined with `uigetpref`, not just the most recent one.

## Input Arguments

### **group**

String specifying the name of the preference group that preference `pref` belongs to. If the group does not already exist, `uigetpref` creates it.

**Default:** None

### **pref**

String specifying the name of the preference that controls whether the dialog displays. If the preference does not already exist, `uigetpref` creates it.

**Default:** None

### **title**

String to display in the dialog box title bar

### **question**

String or cell array of strings specifying a descriptive paragraph for the dialog to display. Use `question` to define what you are asking the user to decide. Clearly state the alternatives and the consequences of choosing among them. The dialog box that `uigetpref` generates inserts line breaks between rows of the string array, between elements of the cell array of strings, and between `'|'` or newline characters within a string vector.

**Default:** None

### **pref\_choices**

String, cell array of strings, or ' | '-separated strings specifying the labels for the dialog box push buttons. The string on the selected push button is returned.

If the internal preference values are different from the strings displayed on the push buttons, provide a 2-by-n cell array of strings. The first row contains the preference strings, and the second row contains the associated push button strings. When `pref_choices` is not a 2-by-n cell array, MATLAB constructs lowercase versions of the button labels and returns them in `pref_value`. If your code tests returned values, make sure it compares them against the appropriate strings.

**Default:** None

### **Name-Value Pair Arguments**

Specify optional comma-separated pairs of `Name, Value` arguments. `Name` is the argument name and `Value` is the corresponding value. `Name` must appear inside single quotes ( ' '). You can specify several name and value pair arguments in any order as `Name1, Value1, ..., NameN, ValueN`.

#### **'CheckboxState'**

State of check box when dialog box opens:

- `false` or `0`: Check box is not initially selected.
- `true` or `1`: Check box is initially selected.

**Default:** 0

#### **'CheckboxString'**

String specifying the label for the check box.

**Default:** 'Do not show this dialog again'

#### **'HelpString'**

String specifying the label for **Help** button.

**Default:** No **Help** button displays.

## **'HelpFcn'**

String or function handle specifying the callback that executes when you click the **Help** button. Also, to have a button to trigger the callback, you must specify the **HelpString** option.

**Default:** doc('uigetpref')

## **'ExtraOptions'**

String or cell array of strings specifying extra buttons. The additional buttons are not mapped to any preference settings. If you click any of these buttons, the dialog closes and **uigetpref** returns the string in value.

**Default:** {}

## **'DefaultButton'**

String specifying the value that **uigetpref** returns if you close the dialog without clicking a button. This string does not have to correspond to any preference or **ExtraOption**.

**Default:** The first button specified in **pref\_choices**

## **Output Arguments**

### **pref\_value**

String containing the preference corresponding to the button you press. If you cancel the dialog by clicking its close box, **uigetpref** returns the label of the first button specified in **pref\_choices** or the value for **DefaultButton**, if specified. After you select the **Do not show this dialog again** check box, **uigetpref** does not display a dialog box when you call it with the same **group** and **pref** arguments. Instead, it returns the last choice you made (your registered preference) in **pref\_value** immediately.

### **dlgshown**

Logical value that specifies the state of the check box when the dialog box closed. The value is 1 if selected, 0 if not selected. After you select the **Do not show this dialog again** check box, `uigetpref` does not display a dialog box when you call it with the same `group` and `pref` arguments. Instead, it returns 0 in `dlgshown` immediately.

## Definitions

### Preferences

Preferences provide the ability to specify how applications behave and how users interact with them. For example, you can set a preference for which products display their documentation in the Help browser, or which messages the Code Analyzer displays. In MathWorks software products, preferences persist across sessions and are stored in a preference data base, the location of which is system-dependent. Use the **Preferences** option on the **File** menu to access all built-in preferences.

`uigetpref` uses the same preference data base as `addpref`, `getpref`, `ispref`, `rmpref`, and `setpref`. However, `uigetpref` registers the preferences it sets as a separate list, so that it and `uisetpref` can manage those preferences.

To modify preferences registered with `uigetpref`, you can use `setpref` and `uisetpref` to explicitly change preference values to 'ask'. If you specify a preference that does not already exist in the preference data base, `uigetpref` creates it.

## Examples

Create a preference dialog for the 'savefigurebeforeclosing' preference in the 'mygraphics' group of preferences.

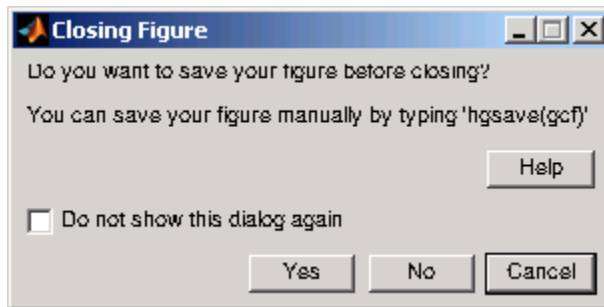

Call `uigetpref` to display the dialog (or not) from a figure window `CloseRequestFcn` callback. The callback code takes action via a switch statement. The action (to delete or not to delete the figure) depends on whether the answer returned by `uigetpref` was `'always'` or `'never'`:

```
function save_figure_perhaps
% Closes figure conditionally, asking whether to save it first.
% User can suppress the dialog from UIGETPREF permanently by selecting
% "Do not show this dialog again".

fig = gcf;
[selectedButton dlgshown] = uigetpref(...
 'mygraphics',... % Group
 'savefigurebeforeclosing',... % Preference
 'Closing Figure',... % Window title
 {'Do you want to save your figure before closing?'
 ''
 'You can save your figure manually by typing ''hgsave(gcf)'''},...
 {'always','never';'Yes','No'},... % Values and button strings
 'ExtraOptions','Cancel',... % Additional button
 'DefaultButton','Cancel',... % Default choice
 'HelpString','Help',... % String for Help button
 'HelpFcn','doc(''closereq'');'); % Callback for Help button
switch selectedButton
case 'always' % Open a Save dialog (without testing if saved before)
 [fileName,pathName,filterIndex] = uinputfile('fig', ...
 'Save current figure', ...
```



```
 'untitled.fig');
if filterIndex == 0 % User cancelled save or named no file
 delete(fig);
else % Use filename returned from UIPUTFILE
 saveas(fig,[pathName fileName])
 delete(fig);
end
case 'never' % Close the figure without saving it
 delete(fig);
case 'cancel' % Do not close the figure
 return
end
```

To execute the example, copy it and paste the code into a new program file. Name the file `save_figure_perhaps.m` and place it on your search path. To use the function as a `CloseRequestFcn`, create a figure as follows:

```
figure('CloseRequestFcn','save_figure_perhaps');
```

Clicking the figure close box or selecting **File > Close** displays the dialog box until you select **Do not show this dialog again**.

## See Also

`ispref` | `addpref` | `getpref` | `setpref` | `prefdir` | `uisetpref` | `rmpref`

## Tutorials

- “Preferences”
- “Confirmation Dialogs Preferences”

# uiimport

---

**Purpose** Import data interactively

**Syntax**

```
uiimport
uiimport(filename)
uiimport('-file')
uiimport('-pastespecial')
S = uiimport(__)
```

**Description** `uiimport` opens a dialog to interactively load data from a file or the clipboard. MATLAB displays a preview of the data in the file.

`uiimport(filename)` opens the file specified in `filename`.

`uiimport('-file')` presents the file selection dialog first.

`uiimport('-pastespecial')` presents the clipboard contents first.

`S = uiimport( __ )` stores the resulting variables as fields in the struct `S`.

**See Also** `load` | `importdata` | `clipboard`

**How To**

- “Supported File Formats for Import and Export”

---

<b>Purpose</b>	Create menus and menu items on figure windows
<b>Syntax</b>	<pre>handle = uimenu('PropertyName',PropertyValue,...) handle = uimenu(parent,'PropertyName',PropertyValue,...)</pre>
<b>Description</b>	<p><code>handle = uimenu('PropertyName',PropertyValue,...)</code> creates a menu in the current figure's menu bar using the values of the specified properties and assigns the menu handle to <code>handle</code>.</p> <p><code>handle = uimenu(parent,'PropertyName',PropertyValue,...)</code> creates a submenu of a parent menu or a menu item on a context menu specified by <code>parent</code> and assigns the menu handle to <code>handle</code>. If <code>parent</code> refers to a figure instead of another <code>uimenu</code> object or a <code>uicontextmenu</code>, MATLAB software creates a new menu on the referenced figure's menu bar.</p>
<b>Tips</b>	<p>MATLAB adds the new menu to the existing menu bar. If the figure does not have a menu bar, MATLAB creates one. Each menu choice can itself be a menu that displays its items when you select it. <code>uimenu</code> accepts property name/property value pairs as well as structures and cell arrays of properties as input arguments.</p> <p>Use the <code>uimenu</code> <code>Callback</code> property to define the action taken when you activate the created menu item.</p> <p>Uimenu only appear in figures whose <code>Window Style</code> is <code>normal</code>. If a figure containing <code>uimenu</code> children is changed to <code>modal</code>, the <code>uimenu</code> children still exist and are contained in the <code>Children</code> list of the figure, but are not displayed until the <code>WindowStyle</code> is changed to <code>normal</code>.</p> <p>The value of the figure <code>MenuBar</code> property affects the content of the figure menu bar. When <code>MenuBar</code> is <code>figure</code>, a set of built-in menus precedes any user-created <code>uimenu</code>s on the menu bar (MATLAB controls the built-in menus and their handles are not available to the user). When <code>MenuBar</code> is <code>none</code>, <code>uimenu</code>s are the only items on the menu bar (that is, the built-in menus do not appear).</p>

# uimenu

See the Uimenu Properties reference page for more information. You can set and query property values after creating a menu with the `set` and `get` functions.

## Examples

This example creates a menu labeled **Workspace** with menu options for creating a new figure window, saving workspace variables, and exiting MATLAB. In addition, it defines an accelerator key for the Quit option.

```
f = uimenu('Label','Workspace');
 uimenu(f,'Label','New Figure','Callback','figure');
 uimenu(f,'Label','Save','Callback','save');
 uimenu(f,'Label','Quit','Callback','exit',...
 'Separator','on','Accelerator','Q');
```

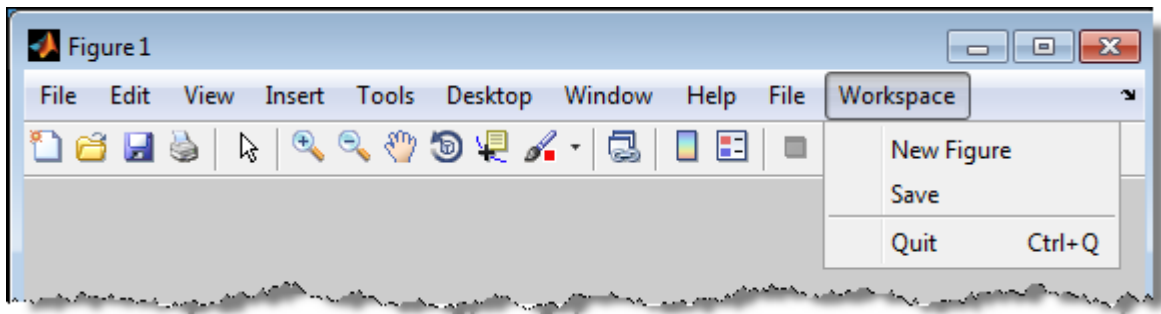

This example creates a new figure with a menu bar that excludes the built-in menus. It creates a **Find** menu with options **Find & Replace**, and **Variable**. For the Variable option, it creates a submenu with options of **Name** and **Value**.

```
f=figure('MenuBar','None');
mh = uimenu(f,'Label','Find');
frh = uimenu(mh,'Label','Find and Replace ...',...
 'Callback','goto');
frh = uimenu(mh,'Label','Variable');
uimenu(frh,'Label','Name...', ...
 'Callback','variable');
```

```
uimenu(frh,'Label','Value...', ...
 'Callback','value');
```

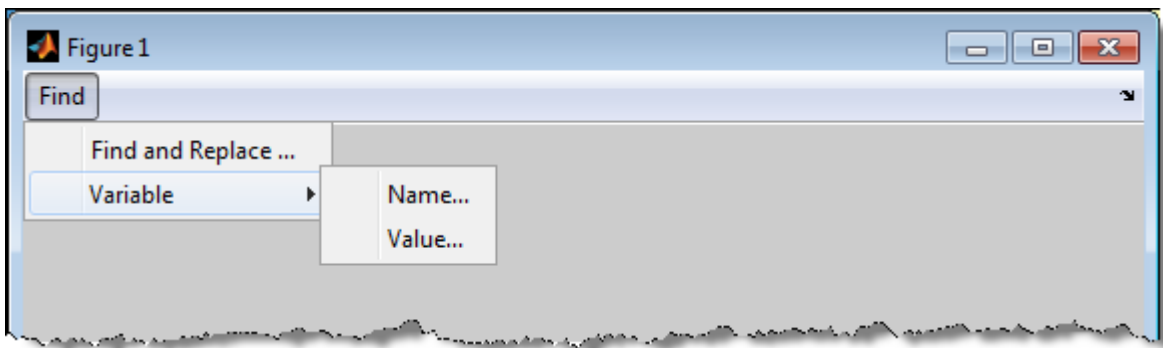

This example creates a context menu, **Font**, on a figure with menu options **Helvetica** and **Monospace**. When you run the code and then right-click anywhere within the figure window, the context menu displays.

```
% Create the UICONTEXTMENU
cmenu = uicontextmenu;

% Create the parent menu
fontmenu = uimenu(cmenu,'label','Font');

% Create the submenus
font1 = uimenu(fontmenu,'label','Helvetica',...
 'Callback','HelvFont');
font2 = uimenu(fontmenu,'label',...
 'Monospace','Callback','MonoFont');
set(gcf,'uicontextmenu',cmenu);
```

# uimenu

---

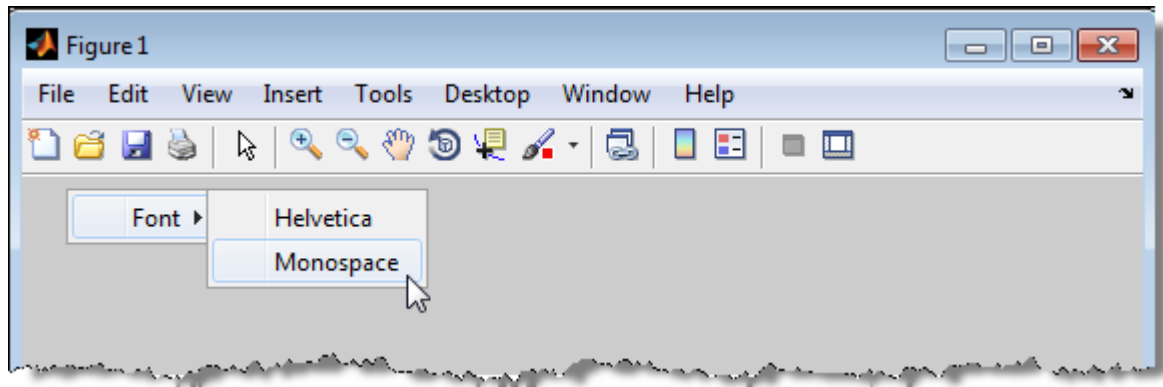

## See Also

[Uimenu Properties](#) | [uicontrol](#) | [uicontextmenu](#) | [gcbo](#) | [set](#) | [get](#) | [figure](#)

## Purpose

Describe menu properties

## Modifying Properties

You can set and query graphics object properties in two ways:

- The Property Inspector is an interactive tool that enables you to see and change object property values. The Property inspector is available from GUIDE, or use the `inspect` function at the command line.
- The `set` and `get` commands enable you to set and query the values of properties

You can set default Uimenu properties on the root, figure and menu levels:

```
set(0, 'DefaultUimenuPropertyName', PropertyValue...)
set(gcf, 'DefaultUimenuPropertyName', PropertyValue...)
set(menu_handle, 'DefaultUimenuPropertyName', PropertyValue...)
```

Where *PropertyName* is the name of the Uimenu property and *PropertyValue* is the value you specify as the default for that property.

For more information about changing the default value of property see “Setting Default Property Values”

## Uimenu Properties

This section lists all properties useful to `uimenu` objects along with valid values and instructions for their use. Curly braces `{ }` enclose default values.

Property Name	Property Description
Accelerator	Keyboard equivalent
BeingDeleted	This object is being deleted
BusyAction	Callback routine interruption
Callback	Control action
Checked	Menu check indicator
Children	Handles of submenus

# Uimenu Properties

---

Property Name	Property Description
CreateFcn	Callback routine executed during object creation
DeleteFcn	Callback routine executed during object deletion
Enable	Enable or disable the uimenu
ForegroundColor	Color of text
HandleVisibility	Whether handle is accessible from command line and GUIs
Interruptible	Callback routine interruption mode
Label	Menu label
Parent	Uimenu object's parent
Position	Relative uimenu position
Separator	Separator line mode
Tag	User-specified object identifier
Type	Class of graphics object
UserData	User-specified data
Visible	Uimenu visibility

Accelerator  
character

*Keyboard equivalent.* An alphabetic character specifying the keyboard equivalent for the menu item. This allows users to select a particular menu choice by pressing the specified character in conjunction with another key, instead of selecting the menu item with the mouse. The key sequence is platform specific:

- For Microsoft Windows systems, the sequence is **Ctrl+Accelerator**. Windows reserves these keys for default



menu items: **c**, **v**, and **x**. For more information, see Keyboard shortcuts for Windows on the Microsoft support Web site.

- For Macintosh systems, the sequence is **Cmd**+Accelerator. Apple reserves these keys for default menu items: **a**, **c**, **v**, and **x**. For more information, see Mac OS X keyboard shortcuts on the Apple Computer support Web site.
- For UNIX systems, the sequence is **Ctrl**+Accelerator. These keys are reserved for default menu items: **o**, **p**, **s**, and **w**. Many UNIX applications also use **a**, **c**, **v**, and **x** in the same manner as the other platforms.

Accelerated menu items do not have to be displayed for the accelerator key to work (you can accelerate a submenu). However, some restrictions apply:

- You can define an accelerator only for menu items that do not have children menus.
- Accelerators work only for menu items that directly execute a callback routine.
- The figure must be in focus when entering the accelerator key sequence.

To remove an accelerator, set `Accelerator` to an empty string, `''`.

For a cross-platform comparison of accelerators, see the article [Table of Keyboard Shortcuts](#).

`BeingDeleted`  
on | {off} (read-only)

*This object is being deleted.* Mechanism to determine if objects are in the process of being deleted. MATLAB sets the `BeingDeleted` property to `on` when the object's delete function callback is called (see the `DeleteFcn` property). It remains set to `on` while the delete function executes, after which the object no longer exists.

# Uimenu Properties

---

For example, an object's delete function calls other functions that act on a number of different objects. If a function does not need to perform an action on an about-be-deleted object, it can check the object's `BeingDeleted` property before acting.

## BusyAction

cancel | {queue}

*Callback routine interruption.* If a callback is executing and the user triggers an event (such as a mouse click) on an object for which a callback is defined, the callback associated with the new event uses the value of `BusyAction` to decide whether or not to attempt to interrupt the executing callback.

- If the value is `cancel`, the event is discarded and the second callback does not execute.
- If the value is `queue`, and the `Interruptible` property of the first callback is `on`, the second callback is added to the event queue and executes in its turn after the first callback finishes execution.

---

**Note** If the interrupting callback is a `DeleteFcn` or `CreateFcn` callback or a figure's `CloseRequest` or `ResizeFcn` callback, it interrupts an executing callback regardless of the value of that object's `Interruptible` property. See the `Interruptible` property for information about controlling a callback's interruptibility.

---

## Callback

string or function handle

*Menu action.* A callback routine that executes whenever you activate the menu or its submenu (if one exists). Activation is platform dependent. Typically, it is clicking the menu or, if the menu has one, its submenu. Define this routine as a string that

is a valid MATLAB expression or the name of a code file. The expression executes in the MATLAB base workspace.

---

**Caution** Do not use a uimenu callback to dynamically change menu items. Deleting, adding, and replacing menu items in a callback can result in a blank menu on some platforms. You can hide, show, and disable menu items in a callback to achieve the same effect. To fully repopulate menu items, delete and create them outside the callback.

---

Checked

on | {off}

*Menu check indicator.* Setting this property to `on` places a check mark next to the corresponding menu item. Setting it to `off` removes the check mark. You can use this feature to create menus that indicate the state of a particular option. For example, suppose you have a menu item called **Show axes** that toggles the visibility of an axes between visible and invisible each time the user selects the menu item. If you want a check to appear next to the menu item when the axes are visible, add the following code to the callback for the **Show axes** menu item:

```
if strcmp(get(gcbo, 'Checked'), 'on')
 set(gcbo, 'Checked', 'off');
else
 set(gcbo, 'Checked', 'on');
end
```

This changes the value of the `Checked` property of the menu item from `on` to `off` or vice versa each time a user selects the menu item.

Note that there is no formal mechanism for indicating that an unchecked menu item will become checked when selected.

# Uimenu Properties

---

---

**Note** This property is ignored for top level and parent menus.

---

## Children

vector of handles

*Handles of submenus.* A vector containing the handles of all children of the uimenu object. The children objects of uimenu are other uimenu objects, which function as submenus. You can use this property to reorder the menus.

## CreateFcn

string or function handle

*Callback routine executed during object creation.* The specified function executes when MATLAB creates a uimenu object. MATLAB sets all property values for the uimenu before executing the CreateFcn callback so these values are available to the callback. Within the function, use `gcbo` to get the handle of the uimenu being created.

Setting this property on an existing uimenu object has no effect.

You can define a default CreateFcn callback for all new uimenu objects. This default applies unless you override it by specifying a different CreateFcn callback when you call `uimenu`. For example, the code

```
set(0, 'DefaultUimenuCreateFcn', 'set(gcbo, ...
 'Visible','on')')
```

creates a default CreateFcn callback that runs whenever you create a new menu. It sets the default Visible property of a uimenu object.

To override this default and create a menu whose Visible property is set to a different value, call `uimenu` with code similar to

```
hpt = uimenu(...,'CreateFcn','set(gcbo,...
'Visible','off'))
```

---

**Note** To override a default `CreateFcn` callback you must provide a new callback and not just provide different values for the specified properties. This is because the `CreateFcn` callback runs after the property values are set, and can override property values you have set explicitly in the `uimenu` call. In the example above, if instead of redefining the `CreateFcn` property for this `uimenu`, you had explicitly set `Visible` to `off`, the default `CreateFcn` callback would have set `Visible` back to the default, i.e., `on`.

---

Do not call `copyobj` or `textwrap` (which calls `copyobj`) inside a `CreateFcn`. The act of copying the `uicontrol` object fires the `CreateFcn` repeatedly, which raises a series of error messages after exceeding the root object's `RecursionLimit` property.

See “Function Handle Callbacks” for information on how to use function handles to define a callback function.

## DeleteFcn

string or function handle

*Delete uimenu callback routine.* A callback routine that executes when you delete the `uimenu` object (e.g., when you issue a `delete` command or cause the figure containing the `uimenu` to reset). MATLAB executes the routine before destroying the object's properties so these values are available to the callback routine.

The handle of the object whose `DeleteFcn` is being executed is accessible only through the root `CallbackObject` property, which is more simply queried using `gcbo`.

See “Function Handle Callbacks” for information on how to use function handles to define a callback function.

# Uimenu Properties

---

## Enable

{on} | off

*Enable or disable the uimenu.* This property controls whether a menu item can be selected. When not enabled (set to `off`), the menu `Label` appears dimmed, indicating the user cannot select it.

## ForegroundColor

ColorSpec X-Windows only

*Color of menu label string.* This property determines color of the text defined for the `Label` property. Specify a color using a three-element RGB vector or one of the MATLAB predefined names. The default text color is black. See `ColorSpec` for more information on specifying color.

## HandleVisibility

{on} | callback | off

*Control access to object's handle.* This property determines when an object's handle is visible in its parent's list of children. When a handle is not visible in its parent's list of children, it is not returned by functions that obtain handles by searching the object hierarchy or querying handle properties. This includes `get`, `findobj`, `gca`, `gcf`, `gco`, `newplot`, `cla`, `clf`, and `close`. Neither is the handle visible in the parent figure's `CurrentObject` property. Handles that are hidden are still valid. If you know an object's handle, you can `set` and `get` its properties, and pass it to any function that operates on handles.

- Handles are always visible when `HandleVisibility` is `on`.
- Setting `HandleVisibility` to `callback` causes handles to be visible from within callback routines or functions invoked by callback routines, but not from within functions invoked from the command line. This provides a means to protect GUIs from command-line users, while allowing callback routines to have complete access to object handles.

- Setting `HandleVisibility` to `off` makes handles invisible at all times. This may be necessary when a callback routine invokes a function that might potentially damage the GUI (such as evaluating a user-typed string), and so temporarily hides its own handles during the execution of that function.

You can set the root `ShowHiddenHandles` property to `on` to make all handles visible, regardless of their `HandleVisibility` settings. This does not affect the values of the `HandleVisibility` properties.

## Interruptible

`{on} | off`

*Callback routine interruption mode.* If a callback is executing and the user triggers an event (such as a mouse click) on an object for which a callback is defined, that callback attempts to interrupt the first callback. MATLAB processes the callbacks according to these factors:

- The `Interruptible` property of the object whose callback is executing
- Whether the executing callback contains `drawnow`, `figure`, `getframe`, `pause`, or `waitfor` statements
- The `BusyAction` property of the object whose callback is waiting to execute

If the `Interruptible` property of the object whose callback is executing is `on` (the default), the callback can be interrupted. Whenever the callback calls one of the `drawnow`, `figure`, `getframe`, `pause`, or `waitfor` functions, the function processes any events in the event queue, including the waiting callback, before performing its defined task.

If the `Interruptible` property of the object whose callback is executing is `off`, the callback cannot be interrupted (except by certain callbacks; see the note below). The `BusyAction` property

# Uimenu Properties

---

of the object whose callback is waiting to execute determines what happens to the callback.

---

**Note** If the interrupting callback is a `DeleteFcn` or `CreateFcn` callback or a figure's `CloseRequest` or `ResizeFcn` callback, it interrupts an executing callback regardless of the value of that object's `Interruptible` property. The interrupting callback starts execution at the next `drawnow`, `figure`, `getframe`, `pause`, or `waitfor` statement. A figure's `WindowButtonDownFcn` callback routine, or an object's `ButtonDownFcn` or `Callback` routine are processed according to the rules described above.

---

## Label

string

*Menu label.* A string specifying the text label on the menu item. You can specify a mnemonic for the label using the '&' character. Except as noted below, the character that follows the '&' in the string appears underlined and selects the menu item when you type **Alt+** followed by that character while the menu is visible. The '&' character is not displayed. To display the '&' character in a label, use two '&' characters in the string:

'O&pen selection' yields **Open selection**

'Save && Go' yields **Save & Go**

'Save&&Go' yields **Save & Go**

'Save& Go' yields **Save& Go** (the space is not a mnemonic)



---

**Tip** Avoid specifying mnemonics for applications designed to run on Macintosh computers. Accessing menus with mnemonics violates the principles of Apple Human Interface Guidelines. However, you can set the `Accelerator` property to access individual menu items with key sequences on a Mac.

---

Avoid including the reserved words, `default`, `remove`, and `factory`, in menu labels unless you escape them. They are case sensitive. To use one of these words in the `Label` property, escape it by preceding it with a backslash (`'\'`) character. For example:

`'\remove'` yields **remove**

`'\default'` yields **default**

`'\factory'` yields **factory**

## Parent

handle

*Uimenu's parent.* The handle of the `uimenu`'s parent object. The parent of a `uimenu` object is the figure on whose menu bar it displays, or the `uimenu` of which it is a submenu. You can move a `uimenu` object to another figure by setting this property to the handle of the new parent.

## Position

scalar

*Relative menu position.* The value of `Position` indicates placement on the menu bar or within a menu. Top-level menus are placed from left to right on the menu bar according to the value of their `Position` property, with 1 representing the left-most position. The individual items within a given menu are placed from top to bottom according to the value of their `Position` property, with 1 representing the top-most position.

# Uimenu Properties

---

## Separator

on | {off}

*Separator line mode.* Setting this property to on draws a dividing line above the menu item.

## Tag

string

*User-specified object label.* The Tag property provides a means to identify graphics objects with a user-specified label. This is particularly useful when constructing interactive graphics programs that would otherwise need to define object handles as global variables or pass them as arguments between callback routines. You can define Tag as any string.

## Type

string (read only)

*Class of graphics object.* For uimenu objects, Type is always the string 'uimenu'.

## UserData

matrix

*User-specified data.* Any matrix you want to associate with the uimenu object. MATLAB does not use this data, but you can access it using the set and get commands.

## Visible

{on} | off

*Uimenu visibility.* By default, all uimenus are visible. When set to off, the uimenu is not visible, but still exists and you can query and set its properties.

<b>Purpose</b>	Convert to 8-bit unsigned integer
<b>Syntax</b>	<code>intArray = uint8(array)</code>
<b>Description</b>	<code>intArray = uint8(array)</code> converts the elements of an array into unsigned 8-bit (1-byte) integers of class <code>uint8</code> .
<b>Input Arguments</b>	<b>array</b> Array of any numeric class, such as <code>single</code> or <code>double</code> . If <code>array</code> is already of class <code>uint8</code> , the <code>uint8</code> function has no effect.
<b>Output Arguments</b>	<b>intArray</b> Array of class <code>uint8</code> . Values range from 0 to $2^8 - 1$ . The <code>uint8</code> function maps any values in <code>array</code> that are outside the limit to the nearest endpoint. For example, <pre>uint8(2^8)    % 2^8 = 256</pre> returns <pre>ans =     255</pre>
<b>Examples</b>	Convert a double array to <code>uint8</code> : <pre>mydata = uint8(magic(10));</pre>
<b>Alternatives</b>	When preallocating integer arrays, specify the class in the call to functions that support a class name input (such as <code>zeros</code> , <code>ones</code> or <code>eye</code> ), rather than calling an integer conversion function. For example, <pre>I = uint8(zeros(100));    % Creates an intermediate array</pre> is not as efficient as <pre>I = zeros(100, 'uint8'); % Preferred</pre>

# uint8

---

## See Also

[double](#) | [single](#) | [uint16](#) | [uint32](#) | [uint64](#) | [int8](#) | [int16](#) | [int32](#) | [int64](#) | [intmax](#) | [intmin](#)

## Tutorials

- [“Integers”](#)
- [“Arithmetic Operations on Integer Classes”](#)

<b>Purpose</b>	Convert to 16-bit unsigned integer
<b>Syntax</b>	<code>intArray = uint16(array)</code>
<b>Description</b>	<code>intArray = uint16(array)</code> converts the elements of an array into unsigned 16-bit (2-byte) integers of class <code>uint16</code> .
<b>Input Arguments</b>	<p><b>array</b></p> <p>Array of any numeric class, such as <code>single</code> or <code>double</code>. If array is already of class <code>uint16</code>, the <code>uint16</code> function has no effect.</p>
<b>Output Arguments</b>	<p><b>intArray</b></p> <p>Array of class <code>uint16</code>. Values range from 0 to <math>2^{16} - 1</math>.</p> <p>The <code>uint16</code> function maps any values in array that are outside the limit to the nearest endpoint. For example,</p> <pre>uint16(2^16) % 2^16 = 65536</pre> <p>returns</p> <pre>ans =     65535</pre>
<b>Examples</b>	<p>Convert a double array to <code>uint16</code>:</p> <pre>mydata = uint16(magic(100));</pre>
<b>Alternatives</b>	<p>When preallocating integer arrays, specify the class in the call to functions that support a class name input (such as <code>zeros</code>, <code>ones</code> or <code>eye</code>), rather than calling an integer conversion function. For example,</p> <pre>I = uint16(zeros(100)); % Creates an intermediate array</pre> <p>is not as efficient as</p> <pre>I = zeros(100, 'uint16'); % Preferred</pre>

# uint16

---

## See Also

`double` | `single` | `uint8` | `uint32` | `uint64` | `int8` | `int16` | `int32` | `int64` | `intmax` | `intmin`

## Tutorials

- “Integers”
- “Arithmetic Operations on Integer Classes”

<b>Purpose</b>	Convert to 32-bit unsigned integer
<b>Syntax</b>	<code>intArray = uint32(array)</code>
<b>Description</b>	<code>intArray = uint32(array)</code> converts the elements of an array into unsigned 32-bit (4-byte) integers of class <code>uint32</code> .
<b>Input Arguments</b>	<p><b>array</b></p> <p>Array of any numeric class, such as <code>single</code> or <code>double</code>. If array is already of class <code>uint32</code>, the <code>uint32</code> function has no effect.</p>
<b>Output Arguments</b>	<p><b>intArray</b></p> <p>Array of class <code>uint32</code>. Values range from 0 to <math>2^{32} - 1</math>.</p> <p>The <code>uint32</code> function maps any values in array that are outside the limit to the nearest endpoint. For example,</p> <pre>uint32(2^32)    % 2^32 = 4294967296</pre> <p>returns</p> <pre>ans =     4294967295</pre>
<b>Examples</b>	<p>Convert a double array to <code>uint32</code>:</p> <pre>mydata = uint32(magic(100));</pre>
<b>Alternatives</b>	<p>When preallocating integer arrays, specify the class in the call to functions that support a class name input (such as <code>zeros</code>, <code>ones</code> or <code>eye</code>), rather than calling an integer conversion function. For example,</p> <pre>I = uint32(zeros(100));    % Creates an intermediate array</pre> <p>is not as efficient as</p> <pre>I = zeros(100, 'uint32'); % Preferred</pre>

# uint32

---

## See Also

[double](#) | [single](#) | [uint8](#) | [uint16](#) | [uint64](#) | [int8](#) | [int16](#) | [int32](#) | [int64](#) | [intmax](#) | [intmin](#)

## Tutorials

- [“Integers”](#)
- [“Arithmetic Operations on Integer Classes”](#)



<b>Purpose</b>	Convert to 64-bit unsigned integer
<b>Syntax</b>	<code>intArray = uint64(array)</code>
<b>Description</b>	<code>uint64(array)</code> converts the elements of an array into unsigned 64-bit (8-byte) integers of class <code>uint64</code> .
<b>Tips</b>	<p>Double-precision floating-point numbers have only 52 bits in the mantissa. Therefore, <code>double</code> values cannot represent all integers greater than <math>2^{53}</math> correctly. Before performing arithmetic operations on values larger than <math>2^{53}</math> in magnitude, convert the values to 64-bit integers. For example,</p> <pre>x = uint64(2^53+1);    % Floating-point arithmetic, loses precision</pre> <p>is not as accurate as the 64-bit integer arithmetic operation:</p> <pre>x = uint64(2^53) + 1; % Preferred</pre>
<b>Input Arguments</b>	<p><b>array</b></p> <p>Array of any numeric class, such as <code>single</code> or <code>double</code>. If <code>array</code> is already of class <code>uint64</code>, the <code>uint64</code> function has no effect.</p>
<b>Output Arguments</b>	<p><b>intArray</b></p> <p>Array of class <code>uint64</code>. Values range from 0 to <math>2^{64} - 1</math>.</p> <p>The <code>uint64</code> function maps any values in <code>array</code> that are outside the limit to the nearest endpoint. For example,</p> <pre>uint64(2^64)    % 2^64 = 18446744073709551616</pre> <p>returns</p> <pre>ans =     18446744073709551615</pre>

# uint64

---

## Examples

Convert a literal value to uint64:

```
x = uint64(9007199254740993);
```

## Alternatives

When preallocating integer arrays, specify the class in the call to functions that support a class name input (such as `zeros`, `ones` or `eye`), rather than calling an integer conversion function. For example,

```
I = uint64(zeros(100)); % Creates an intermediate array
```

is not as efficient as

```
I = zeros(100, 'uint64'); % Preferred
```

## See Also

`double` | `single` | `uint8` | `uint16` | `uint32` | `int8` | `int16` | `int32` | `int64` | `intmax` | `intmin`

## Tutorials

- “Integers”
- “Arithmetic Operations on Integer Classes”

**Purpose** Interactively select file to open and load data

**Syntax**

```
uiopen
uiopen(type)
uiopen(filename)
uiopen(filename, TF)
```

**Description**

uiopen displays the dialog box with the file filter set to all MATLAB files (with file extensions \*.m, \*.mat, \*.fig, \*.mdl, and \*.slx).

uiopen(type) sets the file filter according to the type.

uiopen(filename) displays filename as the default value for **File name** in the dialog box and lists only files having the same extension.

uiopen(filename, TF) directly opens file filename without displaying a dialog box if TF is true, and displays the dialog box if TF is false.

**Tips** When you select a file and click **open**, uiopen does the following:

- Gets the file using uigetfile.
- Opens the file using the open command.
  - Files with a file extension of .m open in the Editor.
  - Variables stored in files with a file extension of .mat appear in the caller's workspace.
  - Files with a file extension of .fig open as figure windows.
  - Files with a file extension of .mdl or .slx open as models in Simulink.
- uiopen('load') is the only the form of uiopen that you can compile into a standalone application. You can create a file selection dialog box that you can compile using uigetfile.
- The uiopen dialog box is modal. A modal dialog box prevents you from interacting with other windows until you respond to the modal one.

- uiopen displays the same dialog box that opens when you use the MATLAB desktop toolstrip to open a file. (On the **Home** tab, in the **File** section, click **Open** )

## Input Arguments

### type

String that specifies the kind of file to show in the dialog box (the file filter). Acceptable values for type are the following.

Type string	Files Displayed
matlab	All MATLAB files (with file extensions *.m, *.mat, *.fig, *.mdl, and *.slx.)
load	All MAT-files (*.mat)
figure	All figure files (*.fig)
simulink	All Simulink model files (*.mdl and *.slx)
editor	All MATLAB files except for .mat, .fig, and .slx files.

### filename

A string, including the file extension, naming a file to open. The filename can be a wildcard character plus extension. For example, \*.txt displays a list of all files with the file extension .txt.

### TF

A MATLAB expression that evaluates to true or false. If true, filename opens directly, without displaying the dialog.

## Definitions

### Modal Dialog

A modal dialog box prevents the user from interacting with other windows before responding. For more information, see WindowStyle in the MATLAB Figure Properties.

## Examples

Filter to display only FIG-files by setting the **Files of type** field to Figures (\*.fig):

```
uiopen('figure')
```

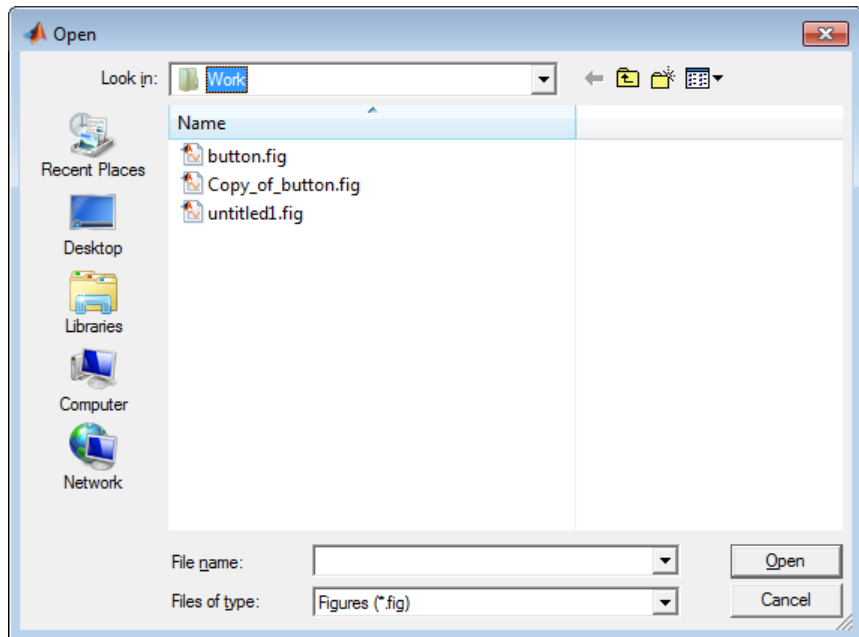

## Alternatives

In MATLAB code or in a command:

- To open a file appropriately based on its file extension, use the `open` function.
- To open a file in the Editor, use the `edit` function.
- To open a MAT-file and load its contents into the workspace, use the `load` function.
- To open a FIG-file, use the `openfig` function.
- To open a file in an application in Microsoft Windows, use the `winopen` function.

# uiopen

---

## **See Also**

`uigetfile` | `uiputfile` | `uisave`

<b>Purpose</b>	Create panel container object
<b>Syntax</b>	<pre>h = uipanel('PropertyName1',value1,'PropertyName2',value2,...) h = uipanel(parent,'PropertyName1',value1,'PropertyName2',value2, ...)</pre>
<b>Description</b>	<p>A <code>uipanel</code> groups components. It can contain user interface controls with which the end user interacts directly. It can also contain axes, other <code>uipanel</code>s, and <code>uibuttongroups</code>. It cannot contain ActiveX controls.</p> <pre>h = uipanel('PropertyName1',value1,'PropertyName2',value2,...)</pre> <p>creates a <code>uipanel</code> container object in a figure, <code>uipanel</code>, or <code>uibuttongroup</code>. Use the <code>Parent</code> property to specify the parent figure, <code>uipanel</code>, or <code>uibuttongroup</code>. If you do not specify a parent, <code>uipanel</code> adds the panel to the current figure. If no figure exists, MATLAB creates one. See the <code>Uipanel Properties</code> reference page for more information.</p> <pre>h = uipanel(parent,'PropertyName1',value1,'PropertyName2',value2, ...)</pre> <p>creates a <code>uipanel</code> in the object specified by the handle, <code>parent</code>. If you also specify a different value for the <code>Parent</code> property, the value of the <code>Parent</code> property takes precedence. <code>parent</code> must be a figure, <code>uipanel</code>, or <code>uibuttongroup</code>.</p> <p>A <code>uipanel</code> object can have axes, <code>uicontrol</code>, <code>uipanel</code>, and <code>uibuttongroup</code> objects as children. For the children of a <code>uipanel</code>, the <code>Position</code> property is interpreted relative to the <code>uipanel</code>. If you move the panel, the children automatically move with it and maintain their positions relative to the panel.</p> <p>After creating a <code>uipanel</code> object, you can set and query its property values using <code>set</code> and <code>get</code>.</p>
<b>Tips</b>	If you set the <code>Visible</code> property of a <code>uipanel</code> object to <code>'off'</code> , any child objects it contains (buttons, button groups, axes, etc.) become invisible

along with the panel itself. However, doing this does *not* affect the settings of the `Visible` property of any of its child objects, even though all of them remain invisible until the `uipanel`'s visibility is set to `'on'`.

## Examples

### Create uipanel with children

Create a `uipanel`, a subpanel in the first panel, and a `pushbutton` in the subpanel.

Both panels use the default `Units` property value, normalized. (Whereas the default `Units` for the `uicontrol` push button is pixels.)

```
h = figure;
hp = uipanel('Title','Main Panel','FontSize',12,...
 'BackgroundColor','white',...
 'Position',[.25 .1 .67 .67]);
hsp = uipanel('Parent',hp,'Title','Subpanel','FontSize',12,...
 'Position',[.4 .1 .5 .5]);
hbsp = uicontrol('Parent',hsp,'String','Push here',...
 'Position',[18 18 72 36]);
```



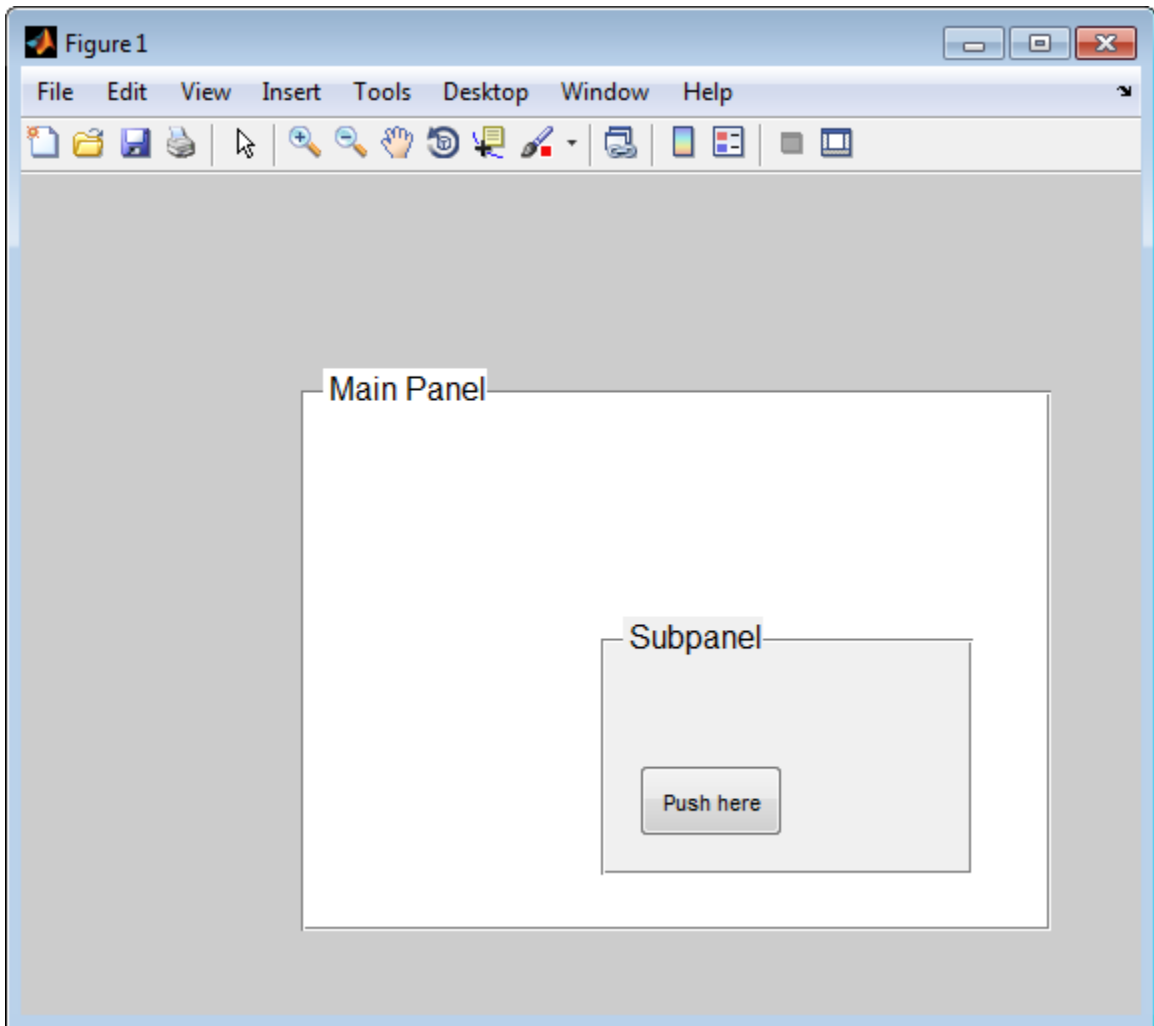

### Uipanel that always matches figure window width

Create a uipanel that always matches the width of the figure, but maintains a constant height. The `ResizeFcn` keeps the uipanel whose

`Tag` is `StatusBar` 20 pixels high, as wide as the figure, and attached to the top of the figure.

Create a file named `match_width.m` on your MATLAB path containing the code that follows. This code uses the `Tag` property to retrieve the `uipanel` handle, and the `gcbo` function to retrieve the figure handle. By default, the figure `Units` property is set to `pixels`. The code sets the panel `Units` to `match`, but restores them to their original setting before the function ends.

```
function match_width(hObject,eventdata)
 u = findobj(gcbo, 'Type','uipanel','Tag','StatusBar');
 fig = gcbo;
 panelunits = get(u,'Units');
 set(u,'Units','pixels');
 % derive the new position for the panel
 figpos = get(fig,'Position');
 upos = [1, figpos(4) - 20, figpos(3), 20];
 set(u,'Position',upos);
 % restore units for the panel
 set(u,'Units',panelunits);
end
```

Run this code in the Command Window to create a figure that specifies the `match_width` function as the `ResizeFcn` callback. (If you do not set the figure `Visible` property set to `off` initially, the `uipanel` does not display until the first time you resize the window. )

```
f = figure('Visible','off');
u = uipanel('Units','Pixels', 'Tag','StatusBar');
set(f,'ResizeFcn', @match_width);
set(f,'Visible','on');
```

Resize the figure window to observe the effect of the `ResizeFcn` callback.

## See Also

`uibuttongroup` | `uicontrol`

## Purpose

Describe panel properties

## Modifying Properties

You can set and query graphics object properties in two ways:

- The Property Inspector is an interactive tool that enables you to see and change object property values. The Property inspector is available from the GUIDE Layout Editor **View** menu, or use the `inspect` function at the command line.
- The `set` and `get` functions enable you to set and query the values of properties.

You can set default uipanel properties by typing:

```
set(h, 'DefaultUipanelPropertyName', PropertyValue...)
```

Where `h` can be the root handle (0), a figure handle, or a uipanel handle. `PropertyName` is the name of the uipanel property and `PropertyValue` is the value you specify as the default for that property.

---

**Note** Default properties you set for uipanel also apply to `uibuttongroups`.

---

For more information about changing the default value of a property see “Setting Default Property Values”. For an example, see the `CreateFcn` property.

## Uipanel Properties

This section lists all properties useful to `uipanel` objects along with valid values and a descriptions of their use. Curly braces `{ }` enclose default values.

Property Name	Description
<code>BackgroundColor</code>	Color of the uipanel background
<code>BeingDeleted</code>	This object is being deleted
<code>BorderType</code>	Type of border around the uipanel area.

# Uipanel Properties

---

Property Name	Description
BorderWidth	Width of the panel border.
BusyAction	Interruption of other callback routines
ButtonDownFcn	Button-press callback routine
Children	All children of the uipanel
Clipping	Clipping of child axes, uipanel, and uibuttongroups to the uipanel. Does not affect child uicontrols.
CreateFcn	Callback routine executed during object creation
DeleteFcn	Callback routine executed during object deletion
FontAngle	Title font angle
FontName	Title font name
FontSize	Title font size
FontUnits	Title font units
FontWeight	Title font weight
ForegroundColor	Title font color
HandleVisibility	Handle accessibility from command line and GUIs
HighlightColor	3-D frame highlight color
Interruptible	Callback routine interruption mode
Parent	Uipanel object's parent
Position	Panel position relative to parent figure or uipanel
ResizeFcn	User-specified resize routine
ShadowColor	3-D frame shadow color

Property Name	Description
Tag	User-specified object identifier
Title	Title string
TitlePosition	Location of title string in relation to the panel
Type	Object class
UIContextMenu	Associates uicontextmenu with the uipanel
Units	Units used to interpret the position vector
UserData	User-specified data
Visible	Uipanel visibility. <hr/> <b>Note</b> Controls the visibility of a uipanel and of its child axes, uibuttongroups, uipanels, and child uicontrols. Setting it does not change their Visible property. <hr/>

BackgroundColor  
ColorSpec

*Color of the uipanel background.* A three-element RGB vector or one of the MATLAB predefined names, specifying the background color. See the ColorSpec reference page for more information on specifying color.

BeingDeleted  
on | {off} (read-only)

*This object is being deleted.* Mechanism to determine if objects are in the process of being deleted. MATLAB sets the BeingDeleted property to on when the object's delete function callback is called (see the DeleteFcn property). It remains set to on while the delete function executes, after which the object no longer exists.

# Uipanel Properties

---

For example, an object's delete function calls other functions that act on a number of different objects. If a function does not need to perform an action on an about-be-deleted object, it can check the object's `BeingDeleted` property before acting.

## BorderType

`none` | `{etchedin}` | `etchedout` | `beveledin` | `beveledout`  
| `line`

*Border of the uipanel area.* Used to define the panel area graphically. Etched and beveled borders provide a 3-D look. Use the `HighlightColor` and `ShadowColor` properties to specify the border color of etched and beveled borders.

A line border is 2-D. Use the `HighlightColor` property to specify its color.

## BorderWidth

`integer`

*Width of the panel border.* The width of the panel borders in pixels. The default border width is 1 pixel. 3-D borders wider than 3 may not appear correctly at the corners.

## BusyAction

`cancel` | `{queue}`

*Callback queuing*

Determines how MATLAB handles the execution of interrupting callbacks.

A *running* callback is the currently executing callback. The *interrupting* callback is the callback that tries to interrupt the *running* callback. The `BusyAction` property of the *interrupting* callback determines how MATLAB handles its execution. When the `BusyAction` property is set to:

- 'queue' — Puts the *interrupting* callback in a queue to be processed after the *running* callback finishes execution.
- 'cancel' — Discards the *interrupting* callback as MATLAB finishes execution.

For information about how the `Interruptible` property of the callback controls whether other callbacks can interrupt the *running* callback, see the `Interruptible` property description.

## `ButtonDownFcn`

string or function handle

*Button-press callback routine.* A callback routine that executes when you press a mouse button while the pointer is in a 5-pixel wide border around the uipanel. This is useful for implementing actions to interactively modify control object properties, such as size and position, when they are clicked on (using the `selectmoveresize` function, for example).

If you define this routine as a string, the string can be a valid MATLAB expression or the name of a code file. The expression executes in the MATLAB workspace.

## `Children`

vector of handles

*Children of the uipanel.* A vector containing the handles of all children of the uipanel. A `uipanel` object's children are axes, uipanels, uibuttongroups, and uicontrols. You can use this property to reorder the children.

## `Clipping`

{on} | off

*Clipping mode.* By default, MATLAB clips a uipanel's child axes, uipanels, and uibuttongroups to the uipanel rectangle. If you set `Clipping` to `off`, the axis, uipanel, or uibuttongroup is displayed outside the panel rectangle. This property does not

# Uipanel Properties

---

affect child uicontrols which, by default, can display outside the panel rectangle.

**CreateFcn**  
string or function handle

*Callback routine executed during object creation.* The specified function executes when MATLAB creates a `uipanel` object. MATLAB sets all property values for the `uipanel` before executing the `CreateFcn` callback so these values are available to the callback. Within the function, use `gcbo` to get the handle of the `uipanel` being created.

Setting this property on an existing `uipanel` object has no effect.

You can define a default `CreateFcn` callback for all new `uipanel`s. This default applies unless you override it by specifying a different `CreateFcn` callback when you call `uipanel`. For example, the code

```
set(0, 'DefaultUipanelCreateFcn', 'set(gcbo, ...
 'FontName', 'arial', 'FontSize', 12)')
```

creates a default `CreateFcn` callback that runs whenever you create a new panel. It sets the default font name and font size of the `uipanel` title.

---

**Note** `Uibuttongroup` takes its default property values from `uipanel`. Defining a default property for all `uipanel`s defines the same default property for all `uibuttongroups`.

---

To override this default and create a panel whose `FontName` and `FontSize` properties are set to different values, call `uipanel` with code similar to

```
hpt = uipanel(..., 'CreateFcn', 'set(gcbo, ...
 'FontName', 'times', 'FontSize', 14)')
```



---

**Note** To override a default `CreateFcn` callback you must provide a new callback and not just provide different values for the specified properties. This is because the `CreateFcn` callback runs after the property values are set, and can override property values you have set explicitly in the `uipushtool` call. In the example above, if instead of redefining the `CreateFcn` property for this uipanel, you had explicitly set `FontSize` to 14, the default `CreateFcn` callback would have set `FontSize` back to the system dependent default.

---

Do not call `copyobj` or `textwrap` (which calls `copyobj`) inside a `CreateFcn`. The act of copying the `uicontrol` object fires the `CreateFcn` repeatedly, which raises a series of error messages after exceeding the root object's `RecursionLimit` property.

See “Function Handle Callbacks” for information on how to use function handles to define a callback function.

## DeleteFcn

string or function handle

*Callback routine executed during object deletion.* A callback routine that executes when you delete the uipanel object (e.g., when you issue a delete command or clear the figure containing the uipanel). MATLAB executes the routine before destroying the object's properties so these values are available to the callback routine. The handle of the object whose `DeleteFcn` is being executed is accessible only through the root `CallbackObject` property, which you can query using `gcbo`.

## FontAngle

{normal} | italic | oblique

*Character slant used in the Title.* MATLAB uses this property to select a font from those available on your particular system. Setting this property to `italic` or `oblique` selects a slanted version of the font, when it is available on your system.

# Uipanel Properties

---

FontName  
string

*Font family used in the Title.* The name of the font in which to display the Title. To display and print properly, this must be a font that your system supports. The default font is system dependent. To eliminate the need to hard code the name of a fixed-width font, which may not display text properly on systems that do not use ASCII character encoding (such as in Japan), set FontName to the string FixedWidth (this string value is case insensitive).

```
set(uicontrol_handle,'FontName','FixedWidth')
```

This then uses the value of the root FixedWidthFontName property which can be set to the appropriate value for a locale from startup.m in the end user's environment. Setting the root FixedWidthFontName property causes an immediate update of the display to use the new font

FontSize  
integer

*Title font size.* A number specifying the size of the font in which to display the Title, in units determined by the FontUnits property. The default size is system dependent.

FontUnits  
inches | centimeters | normalized | {points} | pixels

*Title font size units.* Normalized units interpret FontSize as a fraction of the height of the uipanel. When you resize the uipanel, MATLAB modifies the screen FontSize accordingly. pixels, inches, centimeters, and points are absolute units (1 point = 1/72 inch).

FontWeight  
light | {normal} | demi | bold

*Weight of characters in the title.* MATLAB uses this property to select a font from those available on your particular system. Setting this property to bold causes MATLAB to use a bold version of the font, when it is available on your system.

ForegroundColor  
ColorSpec

*Color used for title.* A three-element RGB vector or one of the MATLAB predefined names, specifying the title color. See the ColorSpec reference page for more information on specifying color.

HandleVisibility  
{on} | callback | off

*Control access to object's handle.* This property determines when an object's handle is visible in its parent's list of children. When a handle is not visible in its parent's list of children, it is not returned by functions that obtain handles by searching the object hierarchy or querying handle properties. This includes `get`, `findobj`, `gca`, `gcf`, `gco`, `newplot`, `cla`, `clf`, and `close`. Neither is the handle visible in the parent figure's `CurrentObject` property. Handles that are hidden are still valid. If you know an object's handle, you can `set` and `get` its properties, and pass it to any function that operates on handles.

- Handles are always visible when `HandleVisibility` is `on`.
- Setting `HandleVisibility` to `callback` causes handles to be visible from within callback routines or functions invoked by callback routines, but not from within functions invoked from the command line. This provides a means to protect GUIs from command-line users, while allowing callback routines to have complete access to object handles.
- Setting `HandleVisibility` to `off` makes handles invisible at all times. This may be necessary when a callback routine invokes a function that might potentially damage the GUI

# Uipanel Properties

---

(such as evaluating a user-typed string), and so temporarily hides its own handles during the execution of that function.

You can set the root `ShowHiddenHandles` property to `on` to make all handles visible, regardless of their `HandleVisibility` settings. This does not affect the values of the `HandleVisibility` properties.

`HighlightColor`  
`ColorSpec`

*3-D frame highlight color.* A three-element RGB vector or one of the MATLAB predefined names, specifying the highlight color. See the `ColorSpec` reference page for more information on specifying color.

`HitTest`  
`{on} | off`

*Selectable by mouse click.* `HitTest` determines if the `uipanel` can become the current object (as returned by the `gco` command and the figure `CurrentObject` property) as a result of a mouse click on the panel. If `HitTest` is `off`, clicking the panel sets the `CurrentObject` to the closest ancestor of the panel that registers `HitTest`. The `uipanel` property `HandleVisibility` must be `'on'` for it to become the `CurrentObject`. If the `uipanel` `HandleVisibility` is `'off'` or `'callback'`, or if the panel and all its ancestors have `HitTest` set to `'off'`, the figure `CurrentObject` is the empty matrix.

`Interruptible`  
`off | {on}`

*Callback routine interruption*

Controls whether MATLAB can interrupt an object's callback function when subsequent callbacks attempt to interrupt it.

For user interface objects, the `Interruptible` property affects the callbacks for these properties only:

- `ButtonDownFcn`
- `KeyPressFcn`
- `KeyReleaseFcn`
- `WindowButtonDownFcn`
- `WindowButtonMotionFcn`
- `WindowButtonUpFcn`
- `WindowKeyPressFcn`
- `WindowKeyReleaseFcn`
- `WindowScrollWheelFcn`

A *running* callback is the currently executing callback. The *interrupting* callback is the callback that tries to interrupt the *running* callback. MATLAB handles both callbacks based on the `Interruptible` property of the object of the *running* callback.

When the `Interruptible` property is set to:

- 'off', MATLAB finishes execution of the *running* callback without any interruptions
- 'on', these conditions apply:
  - If there is a `drawnow`, `figure`, `getframe`, `waitfor`, or `pause` command in the *running* callback, then MATLAB executes the *interrupting* callbacks which are already in the queue and returns to finish execution of the current callback.
  - If one of the above functions is not in the *running* callback, then MATLAB finishes execution of the current callback without any interruption.

# Uipanel Properties

---

The `BusyAction` property of the object of interrupting callback determines whether the callback should be ignored or should be put in the queue.

Setting the `Interruptible` property to `on` (default), allows a callback from other user interface objects to interrupt callback functions originating from this object.

---

**Note** MATLAB does not save the state of properties or the display when an interruption occurs. For example, the handle returned by the `gca` or `gcf` command may be changed as another callback is executed.

---

After the function that interrupts a callback completes, the callback resumes execution where it halted when interrupted. For more information, see “Control Callback Execution and Interruption”.

---

**Note** If the interrupting callback is a `DeleteFcn` or `CreateFcn` callback, or a figure’s `CloseRequest` or `ResizeFcn` callback, it interrupts an executing callback regardless of the value of that object’s `Interruptible` property. The interrupting callback starts execution at the next `drawnow`, `figure`, `getframe`, `pause`, or `waitfor` statement. An object’s `ButtonDownFcn` or `Callback` routine is processed according to the rules described previously in this section.

---

Parent  
handle

*Uipanel parent.* The handle of the uipanel’s parent figure, uipanel, or uibuttongroup. You can move a uipanel object to

another figure, uipanel, or uibuttongroup by setting this property to the handle of the new parent.

## Position

position rectangle

*Size and location of uipanel relative to parent.* The rectangle defined by this property specifies the size and location of the panel within the parent figure window, uipanel, or uibuttongroup. Specify Position as

[left bottom width height]

left and bottom are the distance from the lower-left corner of the parent object to the lower-left corner of the uipanel object. width and height are the dimensions of the uipanel rectangle, including the title. All measurements are in units specified by the Units property.

## ResizeFcn

function handle or string

*Resize callback routine.* MATLAB executes this callback routine whenever a user manually or programmatically resizes the uipanel, or in GUIDE, the Resize behavior option is set to other. You can query the uipanel Position property to determine its new size and position. During execution of the callback routine, the handle to the uipanel being resized is accessible only through the root CallbackObject property, which you can query using gcbo.

All axes, uipanel, uitable and uicontrol objects that have their Units set to normalized automatically resize proportionally to the figure. You can define individual resize functions for any such object as needed. For example, you can use ResizeFcn to maintain a GUI layout that is not directly supported by the MATLAB Position-and-Units paradigm.

# Uipanel Properties

---

For example, consider a GUI layout that maintains an object attached to the top of the figure at a constant height in pixels, but always matches the width of the figure. The following `ResizeFcn` accomplishes this; it keeps the uicontrol whose `Tag` is `'StatusBar'` 20 pixels high, as wide as the figure, and attached to the top of the figure. Note the use of the `Tag` property to retrieve the uicontrol handle, and the `gcbo` function to retrieve the figure handle. The code also does “defensive programming” to save and restores figure `Units`. The callback requires `Units` in pixels in order to work correctly, but takes care not to permanently alter that property.

```
u = findobj('Tag','StatusBar');
fig = gcbo;
old_units = get(fig,'Units');
set(fig,'Units','pixels');
figpos = get(fig,'Position');
upos = [0, figpos(4) - 20, figpos(3), 20];
set(u,'Position',upos);
set(fig,'Units',old_units);
```

You can change the figure `Position` from within a uipanel `ResizeFcn` callback; however, the `ResizeFcn` is not called again as a result.

A figure’s uipanel resize before the figure itself does. Nested uipanel resize from inner to outer, with child `ResizeFcns` being called before parent `ResizeFcns`.

The `print` command can cause the `ResizeFcn` to be called if the `PaperPositionMode` property is set to `manual` and you have defined a resize function. If you do not want your resize function called by `print`, set the `PaperPositionMode` to `auto`.

See “Function Handle Callbacks” for information on how to use function handles to define the callback function.



See [Resize Behavior](#) for information on creating resize functions using [GUIDE](#).

## Selected

on | off (read only)

*Is object selected?* This property indicates whether the panel is selected. When this property is on, MATLAB displays selection handles if the `SelectionHighlight` property is also on. You can, for example, define the `ButtonDownFcn` to set this property, allowing users to select the object with the mouse.

## SelectionHighlight

{on} | off

*Object highlighted when selected.* When the `Selected` property is on, MATLAB indicates the selected state by drawing four edge handles and four corner handles. When `SelectionHighlight` is off, MATLAB does not draw the handles.

## ShadowColor

ColorSpec

*3-D frame shadow color.* A three-element RGB vector or one of the MATLAB predefined names, specifying the shadow color. See the [ColorSpec](#) reference page for more information on specifying color.

## Tag

string

*User-specified object identifier.* The `Tag` property provides a means to identify graphics objects with a user-specified label. You can define `Tag` as any string.

With the `findobj` function, you can locate an object with a given `Tag` property value. This saves you from defining object handles as global variables. For example, this function call returns the

# Uipanel Properties

---

handles of all children (of the specified figures) that have the Tag value 'FormatTb'.

```
h = findobj(figurehandles,'Tag','FormatTb')
```

## Title

string

*Title string.* The text displayed in the panel title. Vertical slash ('|') characters are not interpreted as line breaks and instead show up in the text displayed in the uipanel title. You can position the title using the `TitlePosition` property.

Setting a property value to `default`, `remove`, or `factory` produces the effect described in “Defining Default Values”. To set `Title` to one of these words, you must precede the word with the backslash character. For example,

```
hp = uipanel(...,'Title','\default');
```

## TitlePosition

{lefttop} | centertop | righttop | leftbottom |  
centerbottom | rightbottom

*Location of the title.* This property determines the location of the title string, in relation to the uipanel.

## Type

string (read-only)

*Object class.* This property identifies the kind of graphics object. For uipanel objects, `Type` is always the string 'uipanel'.

## UIContextMenu

handle

*Associate a context menu with a uipanel.* Assign this property the handle of a `Uicontextmenu` object. MATLAB displays the

context menu whenever you right-click the `uipanel`. Use the `uicontextmenu` function to create the context menu.

## Units

`inches` | `centimeters` | `{normalized}` | `points` | `pixels`  
| `characters`

*Units of measurement.* MATLAB uses these units to interpret the `Position` property. For the panel itself, units are measured from the lower-left corner of the figure window. For children of the panel, they are measured from the lower-left corner of the panel.

- Normalized units map the lower-left corner of the panel or figure window to (0,0) and the upper-right corner to (1.0,1.0).
- `pixels`, `inches`, `centimeters`, and `points` are absolute units (1 point = 1/72 inch).
- `Character` units are characters using the default system font; the width of one character is the width of the letter `x`, the height of one character is the distance between the baselines of two lines of text.

If you change the value of `Units`, it is good practice to return it to its default value after completing your computation so as not to affect other functions that assume `Units` is set to the default value.

## UserData

matrix

*User-specified data.* Any data you want to associate with the `uipanel` object. MATLAB does not use this data, but you can access it using `set` and `get`.

## Visible

`{on}` | `off`

*Uipanel visibility.* By default, a `uipanel` object is visible. When set to `'off'`, the `uipanel` is not visible, as are all child objects of

# Uipanel Properties

---

the panel. When a panel is hidden in this manner, you can still query and set its properties.

---

**Note** The value of a uipanel's `Visible` property determines whether its child components, such as axes, buttons, `uibuttongroups`, and other uipanel, are visible. However, changing the `Visible` property of a panel does *not* change the settings of the `Visible` property of its child components even though hiding the panel causes them to be hidden.

---

<b>Purpose</b>	Create push button on toolbar
<b>Syntax</b>	<pre>hpt = uipushtool hpt = uipushtool('PropertyName1',value1,'PropertyName2',value2,...) hpt = uipushtool(ht,...)</pre>
<b>Description</b>	<p><code>hpt = uipushtool</code> creates a push button on the <code>uitoolbar</code> at the top of the current figure window, sets all its properties to default values, and returns a handle to the tool. If no <code>uitoolbar</code> exists, one is created. The <code>uitoolbar</code> is the parent of the <code>uipushtool</code>. Use the returned handle <code>hpt</code> to set properties of the tool. The <code>ClickedCallback</code> passes the handle as its first argument. The button has no icon, but its border highlights when you hover over it with the mouse cursor. Add an icon by setting <code>CData</code> for the tool.</p> <pre>hpt = uipushtool('PropertyName1',value1,'PropertyName2',value2,...) , creates a uipushtool and returns a handle to it. uipushtool assigns the specified property values, and assigns default values to the remaining properties. You can change the property values at a later time using the <code>set</code> function. You can specify properties as parameter name/value pairs, cell arrays containing parameter names and values, or structures with fields containing parameter names and values as input arguments. For a complete list, see <code>Uipushtool Properties</code>. Type <code>get(hpt)</code> to see a list of <code>uipushtool</code> object properties and their current values. Type <code>set(hpt)</code> to see a list of <code>uipushtool</code> object properties that you can set and their legal property values.</pre> <p><code>hpt = uipushtool(ht,...)</code> creates a button with <code>ht</code> as a parent. <code>ht</code> must be a <code>uitoolbar</code> handle.</p> <p><code>Uipushtools</code> appear in figures whose <code>Window Style</code> is <code>'normal'</code> or <code>'docked'</code>. Push tools do not appear in figures with <code>'modal'</code> <code>WindowStyle</code>. If you change the <code>WindowStyle</code> of a figure containing a <code>uitoolbar</code> and its <code>uipushtool</code> children to <code>'modal'</code>, the <code>uipushtools</code> continue to exist as <code>Children</code> of the <code>uitoolbar</code>. However, they do</p>

not display until you change the figure `WindowStyle` to `'normal'` or `'docked'`.

Unlike push buttons, uipushtools have no way to indicate that you have double-clicked them. That is, a double click does not set the figure `SelectionType` property to `'open'`. Double-clicking a uipushtool simply executes its `ClickedCallback` twice in succession. Also, uipushtools cannot have context menus.

## Examples

### Toolbar with push button

Create a `uitoolbar` object and place a `uipushtool` object on it.

```
h = figure('ToolBar','none');
ht = uitoolbar(h);
% Use a MATLAB icon for the tool
[X map] = imread(fullfile(...
 matlabroot,'toolbox','matlab','icons','matlabicon.gif'));
% Convert indexed image and colormap to truecolor
icon = ind2rgb(X,map);
% Create a uipushtool in the toolbar
hpt = uipushtool(ht,'CData',icon,...
 'TooltipString','Toolbar push button',...
 'ClickedCallback',...
 'disp(''Thank you for clicking a uipushtool.'')')
```

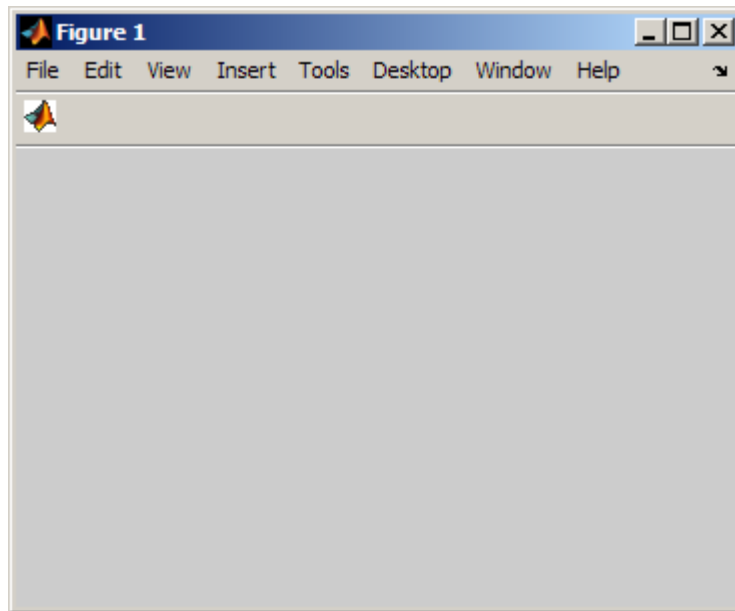
**Alternatives**

You can also create toolbars with push tools using GUIDE.

**See Also**

`get` | `set` | `uicontrol` | `uitoggletool` | `uitoolbar` | `Uipushtool`  
Properties

**Tutorials**

- “Axes, Menus, and Toolbars in Programmatic GUIs”

**How To**

- “Create Toolbars for Programmatic GUIs”

# Uipushtool Properties

---

## Purpose

Describe push tool properties

## Modifying Properties

You can set and query graphics object properties in two ways:

- The Property Inspector is an interactive tool that enables you to see and change object property values. The Property inspector is available from GUIDE, or use the `inspect` function at the command line.
- The `set` and `get` functions enable you to set and query the values of properties.

You can set default Uipushtool properties by typing:

```
set(h, 'DefaultUipushtoolPropertyName', PropertyValue...)
```

Where `h` can be the root handle (0), a figure handle, a uicontrol handle, or a uipushtool handle. *PropertyName* is the name of the Uipushtool property and *PropertyValue* is the value you specify as the default for that property.

For more information about changing the default value of a property see [Setting Default Property Values](#).

## Uipushtool Properties

This section lists all properties useful to uipushtool objects along with valid values and a descriptions of their use. Curly braces { } enclose default values.

Property	Purpose
BeingDeleted	This object is being deleted.
BusyAction	Callback routine interruption.
CData	Truecolor image displayed on the control.
ClickedCallback	Control action.
CreateFcn	Callback routine executed during object creation.
DeleteFcn	Delete uipushtool callback routine.



Property	Purpose
Enable	Enable or disable the uipushtool.
HandleVisibility	Control access to object's handle.
Interruptible	Callback routine interruption mode.
Parent	Handle of uipushtool's parent.
Separator	Separator line mode
Tag	User-specified object label.
TooltipString	Content of object's tooltip.
Type	Object class.
UIContextMenu	Uicontextmenu object associated with the uipushtool
UserData	User specified data.
Visible	Uipushtool visibility.

## BeingDeleted

on | {off} (read only)

*This object is being deleted.* The `BeingDeleted` property provides a mechanism that you can use to determine if objects are in the process of being deleted. MATLAB software sets the `BeingDeleted` property to `on` when the object's delete function callback is called (see the `DeleteFcn` property). It remains set to `on` while the delete function executes, after which the object no longer exists.

For example, some functions may not need to perform actions on objects that are being deleted, and therefore, can check the object's `BeingDeleted` property before acting.

## BusyAction

cancel | {queue}

# Uipushtool Properties

---

## *Callback queuing*

Determines how MATLAB handles the execution of interrupting callbacks.

A *running* callback is the currently executing callback. The *interrupting* callback is the callback that tries to interrupt the *running* callback. The `BusyAction` property of the *interrupting* callback determines how MATLAB handles its execution. When the `BusyAction` property is set to:

- 'queue' — Puts the *interrupting* callback in a queue to be processed after the *running* callback finishes execution.
- 'cancel' — Discards the *interrupting* callback as MATLAB finishes execution.

For information about how the `Interruptible` property of the callback controls whether other callbacks can interrupt the *running* callback, see the `Interruptible` property description.

## `CData`

3-dimensional array

*Truecolor image displayed on control.* An  $n$ -by- $m$ -by-3 array of RGB values that defines a truecolor image displayed on either a push button or toggle button. Each value must be between 0.0 and 1.0. If your `CData` array is larger than 16 in the first or second dimension, it may be clipped or cause other undesirable effects. If the array is clipped, only the center 16-by-16 part of the array is used.

## `ClickedCallback`

string or function handle

*Control action.* A routine that executes when the uipushtool's `Enable` property is set to on, and you press a mouse button while the pointer is on the push tool itself or in a 5-pixel wide border around it.

## CreateFcn

string or function handle

*Callback routine executed during object creation.* The specified function executes when MATLAB creates a uipushtool object. MATLAB sets all property values for the uipushtool before executing the CreateFcn callback so these values are available to the callback. Within the function, use `gcbo` to get the handle of the push tool being created.

Setting this property on an existing uipushtool object has no effect.

You can define a default CreateFcn callback for all new uipushtools. This default applies unless you override it by specifying a different CreateFcn callback when you call `uipushtool`. For example, the code

```
imga(:, :, 1) = rand(20);
imga(:, :, 2) = rand(20);
imga(:, :, 3) = rand(20);
set(0, 'DefaultUipushtoolCreateFcn', ...
 'set(gcbo, 'Cdata', imga)')
```

creates a default CreateFcn callback that runs whenever you create a new push tool. It sets the default image `imga` on the push tool.

To override this default and create a push tool whose `Cdata` property is set to a different image, call `uipushtool` with code similar to

```
a = [.05:.05:0.95];
imgb(:, :, 1) = repmat(a, 19, 1)';
imgb(:, :, 2) = repmat(a, 19, 1);
imgb(:, :, 3) = repmat(flip(a, 2), 19, 1);
hpt = uipushtool(..., 'CreateFcn', ...
 'set(gcbo, 'CData', imgb)', ...)
```

# Uipushtool Properties

---

---

**Note** To override a default `CreateFcn` callback you must provide a new callback and not just provide different values for the specified properties. This is because the `CreateFcn` callback runs after the property values are set, and can override property values you have set explicitly in the `uipushtool` call. In the example above, if instead of redefining the `CreateFcn` property for this push tool, you had explicitly set `CData` to `imgb`, the default `CreateFcn` callback would have set `CData` back to `imga`.

---

Do not call `copyobj` or `textwrap` (which calls `copyobj`) inside a `CreateFcn`. The act of copying the `uicontrol` object fires the `CreateFcn` repeatedly, which raises a series of error messages after exceeding the root object's `RecursionLimit` property.

See “Function Handle Callbacks” for information on how to use function handles to define a callback function.

`DeleteFcn`  
string or function handle

*Callback routine executed during object deletion.* A callback routine that executes when you delete the `uipushtool` object (e.g., when you call the `delete` function or cause the figure containing the `uipushtool` to reset). MATLAB executes the routine before destroying the object's properties so these values are available to the callback routine.

The handle of the object whose `DeleteFcn` is being executed is accessible only through the root `CallbackObject` property, which you can query using `gcbo`.

See “Function Handle Callbacks” for information on how to use function handles to define a callback function.

`Enable`  
{on} | off

*Enable or disable the uipushtool.* This property controls how uipushtools respond to mouse button clicks, including which callback routines execute.

- **on** – The uipushtool is operational (the default).
- **off** – The uipushtool is not operational and its image (set by the `Cdata` property) is grayed out.

When you left-click a uipushtool whose `Enable` property is **on**, MATLAB performs these actions in this order:

- 1** Executes the push tool's `ClickedCallback` routine.
- 2** Does *not* set the figure `CurrentPoint` property and does not execute the figure's `WindowButtonDownFcn` callback.
- 3** Does *not* set the figure `SelectionType` property.

When you left-click a uipushtool whose `Enable` property is **off**, or when you right-click a uipushtool whose `Enable` property has any value, no action is reported, no callback executes, and neither the `SelectionType` nor `CurrentPoint` figure properties are modified.

`HandleVisibility`  
{on} | callback | off

*Control access to object's handle.* This property determines when an object's handle is visible in its parent's list of children. When a handle is not visible in its parent's list of children, it is not returned by functions that obtain handles by searching the object hierarchy or querying handle properties. This includes `get`, `findobj`, `gca`, `gcf`, `gco`, `newplot`, `cla`, `clf`, and `close`. Neither is the handle visible in the parent figure's `CurrentObject` property. Handles that are hidden are still valid. If you know an object's handle, you can `set` and `get` its properties, and pass it to any function that operates on handles.

- Handles are always visible when `HandleVisibility` is **on**.

# Uipushtool Properties

---

- Setting `HandleVisibility` to `callback` causes handles to be visible from within callback routines or functions invoked by callback routines, but not from within functions invoked from the command line. This provides a means to protect GUIs from command-line users, while allowing callback routines to have complete access to object handles.
- Setting `HandleVisibility` to `off` makes handles invisible at all times. This may be necessary when a callback routine invokes a function that might potentially damage the GUI (such as evaluating a user-typed string), and so temporarily hides its own handles during the execution of that function.

You can set the root `ShowHiddenHandles` property to `on` to make all handles visible, regardless of their `HandleVisibility` settings. This does not affect the values of the `HandleVisibility` properties.

`HitTest`  
{on} | off

*Selectable by mouse click.* This property has no effect on uipushtool objects.

---

**Note** Use of the uipushtool `HitTest` property is not recommended. This property might be removed in a future release.

---

`Interruptible`  
off | {on}

*Callback routine interruption*

Controls whether MATLAB can interrupt an object's callback function when subsequent callbacks attempt to interrupt it.

For user interface objects, the `Interruptible` property affects the callbacks for these properties only:

- `ButtonDownFcn`
- `KeyPressFcn`
- `KeyReleaseFcn`
- `WindowButtonDownFcn`
- `WindowButtonMotionFcn`
- `WindowButtonUpFcn`
- `WindowKeyPressFcn`
- `WindowKeyReleaseFcn`
- `WindowScrollWheelFcn`

A *running* callback is the currently executing callback. The *interrupting* callback is the callback that tries to interrupt the *running* callback. MATLAB handles both callbacks based on the `Interruptible` property of the object of the *running* callback.

When the `Interruptible` property is set to:

- 'off', MATLAB finishes execution of the *running* callback without any interruptions
- 'on', these conditions apply:
  - If there is a `drawnow`, `figure`, `getframe`, `waitfor`, or `pause` command in the *running* callback, then MATLAB executes the *interrupting* callbacks which are already in the queue and returns to finish execution of the current callback.
  - If one of the above functions is not in the *running* callback, then MATLAB finishes execution of the current callback without any interruption.

# Uipushtool Properties

---

The `BusyAction` property of the object of interrupting callback determines whether the callback should be ignored or should be put in the queue.

Setting the `Interruptible` property to `on` (default), allows a callback from other user interface objects to interrupt callback functions originating from this object.

---

**Note** MATLAB does not save the state of properties or the display when an interruption occurs. For example, the handle returned by the `gca` or `gcf` command may be changed as another callback is executed.

---

After the function that interrupts a callback completes, the callback resumes execution where it halted when interrupted. For more information, see “Control Callback Execution and Interruption”.

---

**Note** If the interrupting callback is a `DeleteFcn` or `CreateFcn` callback, or a figure’s `CloseRequest` or `ResizeFcn` callback, it interrupts an executing callback regardless of the value of that object’s `Interruptible` property. The interrupting callback starts execution at the next `drawnow`, `figure`, `getframe`, `pause`, or `waitfor` statement. An object’s `ButtonDownFcn` or `Callback` routine is processed according to the rules described previously in this section.

---

Parent  
handle

*Uipushtool parent.* The handle of the uipushtool’s parent toolbar. You can move a uipushtool object to another toolbar by setting this property to the handle of the new parent.



## Separator

on | {off}

*Separator line mode.* Setting this property to on draws a dividing line to the left of the uipushtool.

## Tag

string

*User-specified object identifier.* The Tag property provides a means to identify graphics objects with a user-specified label. You can define Tag as any string.

With the `findobj` function, you can locate an object with a given Tag property value. This saves you from defining object handles as global variables. For example, this function call returns the handles of all children (of the specified toolbars) that have the Tag value 'Copy'.

```
h = findobj(uitoolbarhandles, 'Tag', 'Copy')
```

## TooltipString

string

*Content of tooltip for object.* The TooltipString property specifies the text of the tooltip associated with the uipushtool. When the user moves the mouse pointer over the control and leaves it there, the tooltip is displayed.

To create a tooltip that has more than one line of text, use `sprintf` to generate a string containing newline (`\n`) characters and then set the TooltipString to that value. For example:

```
h = uipushtool;
s = sprintf('Pushtool tooltip line 1\nPushtool tooltip line 2');
set(h, 'TooltipString', s)
```

# Uipushtool Properties

---

## Type

string (read-only)

Object class. This property identifies the kind of graphics object. For uipushtool objects, Type is always the string 'uipushtool'.

## UINavigationController

handle

*Associate a context menu with uicontrol.* This property has no effect on uipushtool objects.

## UserData

array

*User specified data.* You can specify UserData as any array you want to associate with the uipushtool object. The object does not use this data, but you can access it using the `set` and `get` functions.

## Visible

{on} | off

*Uipushtool visibility.* By default, all uipushtools are visible. When set to off, the uipushtool is not visible, but still exists and you can query and set its properties.

**Purpose** Open standard dialog box for saving files

**Syntax**

```
FileName = uiputfile
[FileName,PathName] = uiputfile
[FileName,PathName,FilterIndex] = uiputfile(FilterSpec)
[FileName,PathName,FilterIndex] = uiputfile(FilterSpec,DialogTitle)
[FileName,PathName,FilterIndex] = uiputfile(FilterSpec,DialogTitle,
 DefaultName)
```

## Description

---

**Note** Successful execution of `uiputfile` does not create a file; it only returns the name of a new or existing file that you designate.

---

`FileName = uiputfile` displays a modal dialog box for selecting or specifying a file you want to create or save. The dialog box lists the files and folders in the current folder. If the selected or specified file name is valid, `uiputfile` returns it in `FileName`.

`[FileName,PathName] = uiputfile` also returns the path to `FileName` in `PathName`, or if you cancel the dialog, returns 0 for both arguments. If you do not provide any output arguments, the file name alone is returned in `ans`.

`[FileName,PathName,FilterIndex] = uiputfile(FilterSpec)` displays only those files with extensions that match `FilterSpec`. On some platforms `uiputfile` also displays in gray any files that do not match `FilterSpec`. The `uiputfile` function appends 'All Files' to the list of file types. `FilterSpec` can be a string or a cell array of strings, and can include the \* and ? wildcard characters. For example, '\*.m' lists all MATLAB program files in a folder.

`FilterSpec` can be a string that contains a file name. `uiputfile` displays the file name selected in the **File name** field and uses the file extension as the default filter. The `FilterSpec` string can include a path, or consist of a path only. To specify a folder only, make the last character in `DefaultName` '\ ' or '/ '. A path can contain special

path characters, such as '.', '..', '/', '\', or '~'. For example, '../\*.\*m' lists all program files in the folder above the current folder. If `FilterSpec` is a cell array of strings, the first column contains a list of file extensions. The optional second column contains a corresponding list of descriptions. These descriptions replace the default descriptions in the **Save as type** pop-up menu. A description cannot be an empty string. See the “Examples” on page 1-7396 for illustration of using cell arrays as `FilterSpec`. If you do not specify `FilterSpec`, `uiputfile` uses the default list of file types (all MATLAB files). `FilterIndex` is the index of the filter selected in the dialog box. Indexing starts at 1. If you click the **Cancel** button, close the dialog window, or if the file does not exist, `uiputfile` returns `FilterIndex` as 0.

```
[FileName,PathName,FilterIndex] =
uiputfile(FilterSpec,DialogTitle)displays a dialog box that has
the title DialogTitle. To use the default file types and to specify a
dialog title, enter uiputfile(' ', 'DialogTitle')
```

```
[FileName,PathName,FilterIndex] =
uiputfile(FilterSpec,DialogTitle, DefaultName)displays a dialog
box in which the file name specified by DefaultName appears in the
File name field. DefaultName can also be a path or a path+filename.
To specify a folder only, make the last character in DefaultName '\\' or
'/'. In this case, uiputfile opens the dialog box in the folder specified
by the path. If you specify a path in DefaultName that does not exist,
uiputfile opens the dialog box in the current folder. You can use
'.', '..', '\', '/', or ~ in the DefaultName argument.
```

When typing into the dialog box, if you include either of the wildcard characters '\*' or '?' in a file name, `uiputfile` does not respond to clicking **Save**. The dialog box remains open until you cancel it or remove the wildcard characters. This restriction applies to all platforms, even to file systems that permit these characters in file names.

If you select or specify an existing file name, a warning dialog box opens stating that the file already exists and asks if you want to replace it.

Select **Yes** to replace the existing file or **No** to return to the dialog to select another file name. Selecting **Yes** returns the name of the file. Selecting **No** returns 0.

For Microsoft Windows platforms, the dialog box is the Windows dialog box native to your platform, and thus can differ from what you see in the examples that follow.

For UNIX platforms, the dialog box is like the one shown in the following figure.

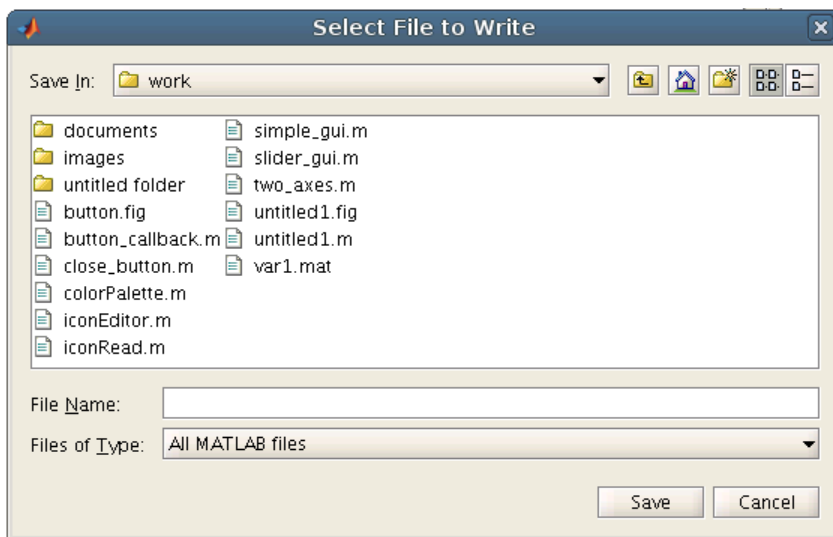

For Mac platforms, the dialog box is like the one shown in the following figure.

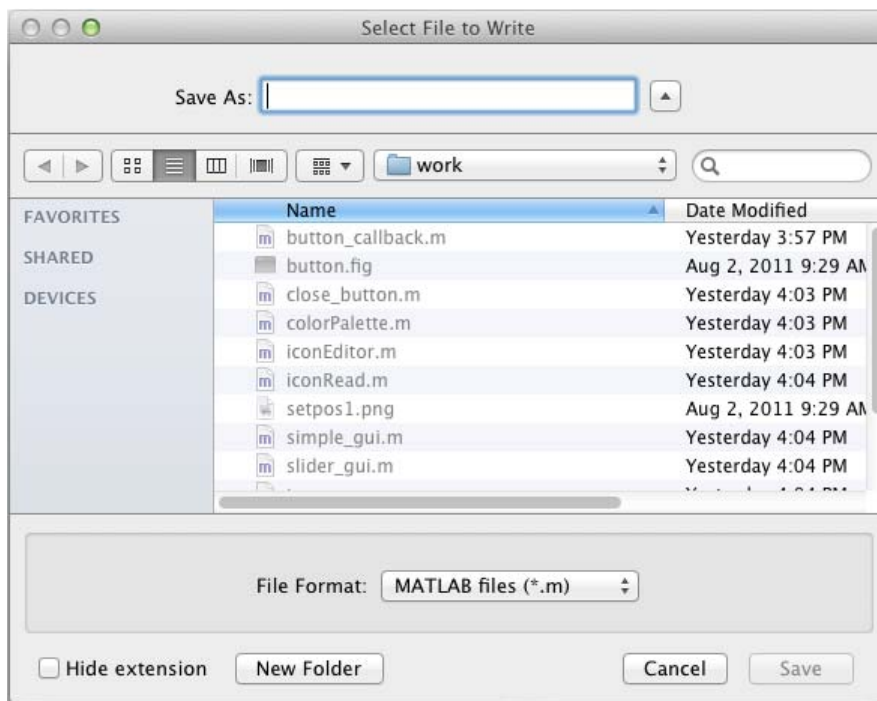

---

**Note** A modal dialog box prevents you from interacting with other MATLAB windows before responding. To block MATLAB program execution as well, use the `uiwait` function. For more information about modal dialog boxes, see `WindowState` in MATLAB Figure Properties.

---

## Examples

The following statement displays a dialog box entitled 'Save file name', setting the **File name** field to `animinit.m` and the filter to program files (`*.m`). Because `FilterSpec` is a string, the filter also includes All Files (`*.*`)

```
[file,path] = uiputfile('animinit.m','Save file name');
```

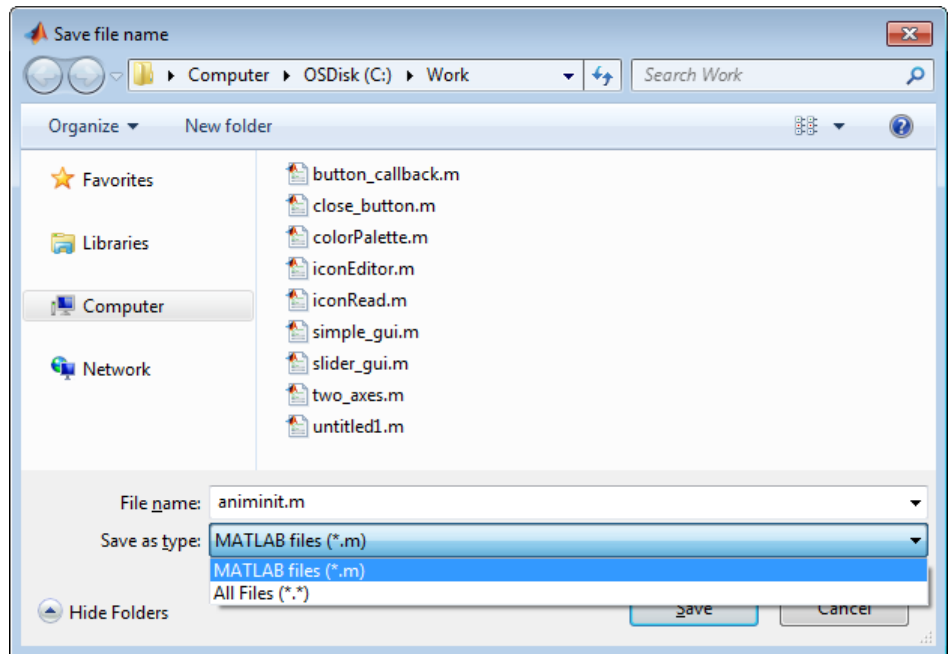

The following statement displays a dialog box entitled 'Save Workspace As' with the filter set to MAT-files.

```
[file,path] = uiputfile('*.mat','Save Workspace As');
```

# uiputfile

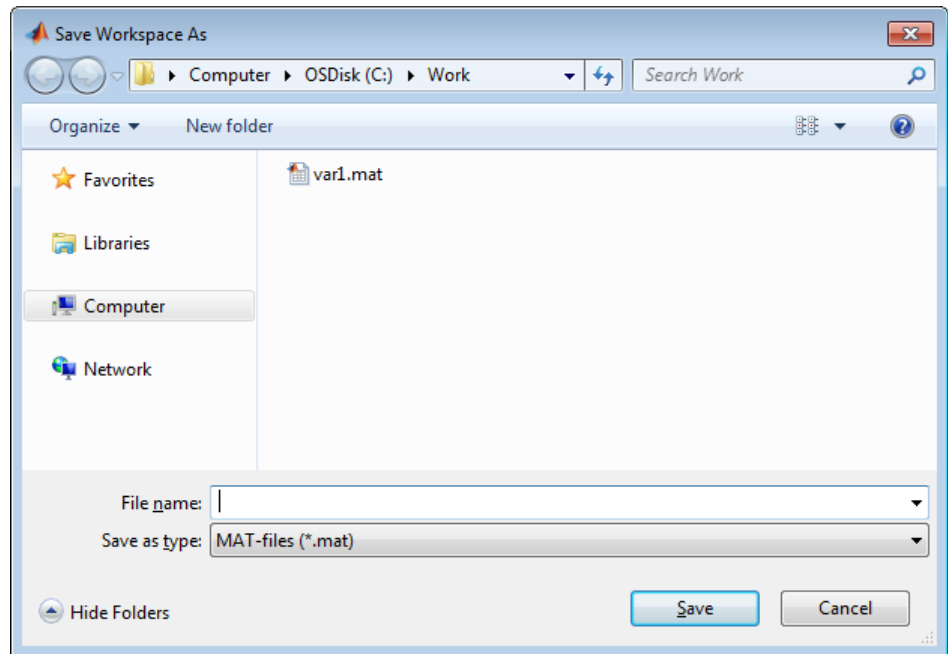

To display several file types in the **Save as type** list box, separate each file extension with a semicolon, as in the following code. `uiputfile` displays a default description for each known file type, such as "Model files" for Simulink `.mdl` and `.slx` files.

```
[filename, pathname] = uiputfile(...
 {'*.m'; '*.slx'; '*.mat'; '*.*'}, ...
 'Save as');
```



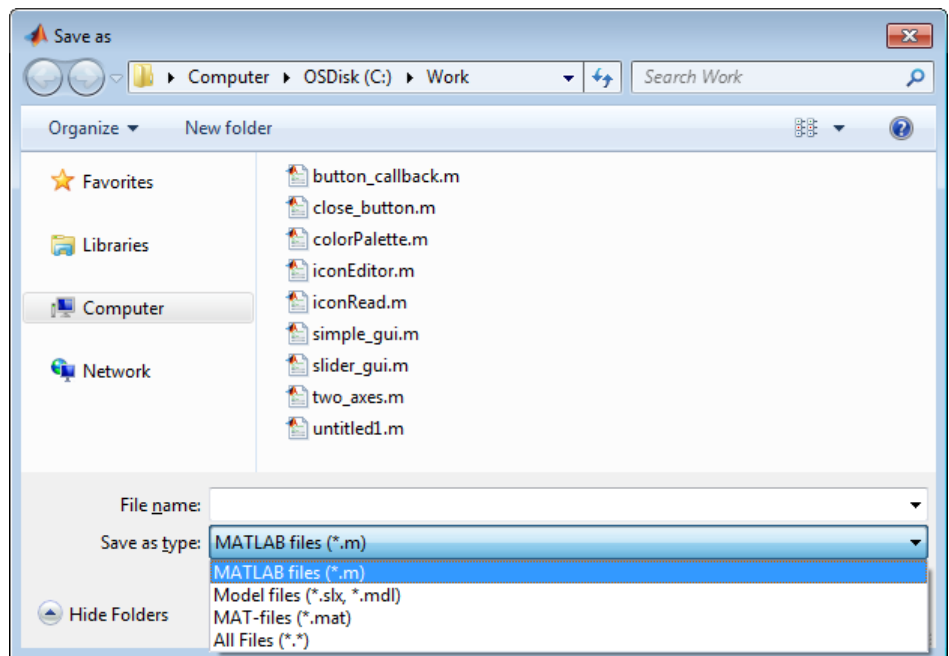

To create a list of file types and give them descriptions that are different from the defaults, use a cell array. This example also associates multiple file types with the 'MATLAB Files' and 'Models' descriptions.

```
[filename, pathname, filterindex] = uiputfile(...
{'*.m;*.fig;*.mat;*.slx;*.mdl',...
'MATLAB Files (*.m,*.fig,*.mat,*.slx,*.mdl)';
 '*.m', 'program files (*.m)';...
 '*.fig', 'Figures (*.fig)';...
 '*.mat', 'MAT-files (*.mat)';...
 '*.slx;*.mdl', 'Models (*.slx,*.mdl)';...
 '.*', 'All Files (*.*)'},...
'Save as');
```

# uiputfile

The first column of the cell array contains the file extensions, while the second contains the descriptions you want to provide for the file types. The first entry of column one contains several extensions separated by semicolons. These file types all associate with the description 'MATLAB Files (\*.m;\*.fig;\*.mat;\*.slx;\*.mdl)'. The code produces the dialog box shown in the following figure.

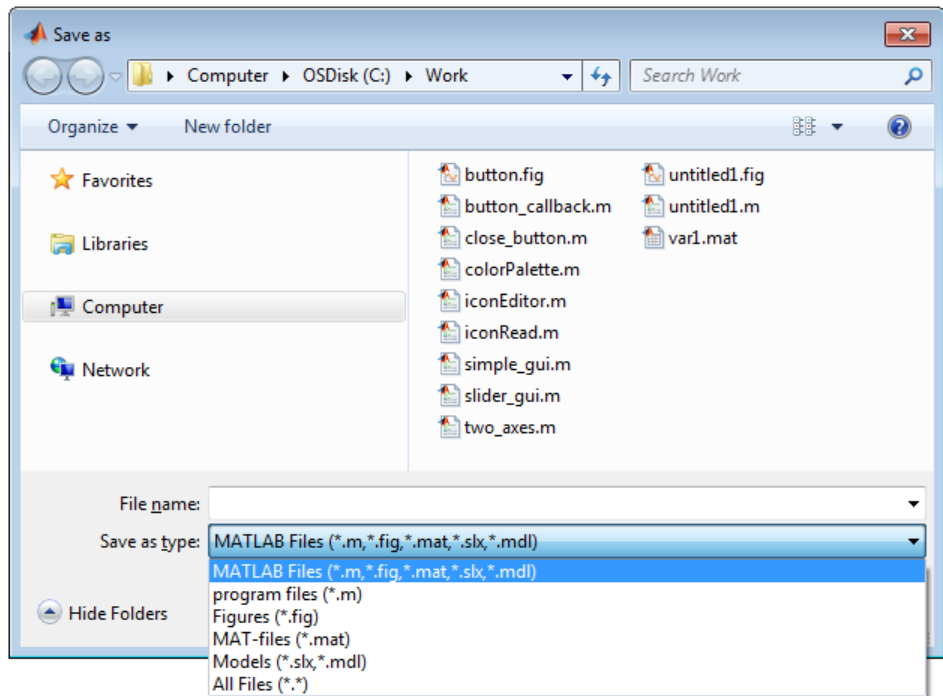

The following code checks for the existence of the file and displays a message about the result of the file selection operation.

```
[filename, pathname] = uiputfile('*.m',...
 'Pick a MATLAB program file');
if isequal(filename,0) || isequal(pathname,0)
 disp('User selected Cancel')
```

```

else
 disp(['User selected ',fullfile(pathname,filename)])
end

```

Select or enter a file name for saving a figure as an image in one of four formats, described in a cell array.

```

uiputfile({'*.jpg;*.tif;*.png;*.gif','All Image Files';...
 '*.','All Files' },'Save Image',...
 'C:\Work\newfile.jpg')

```

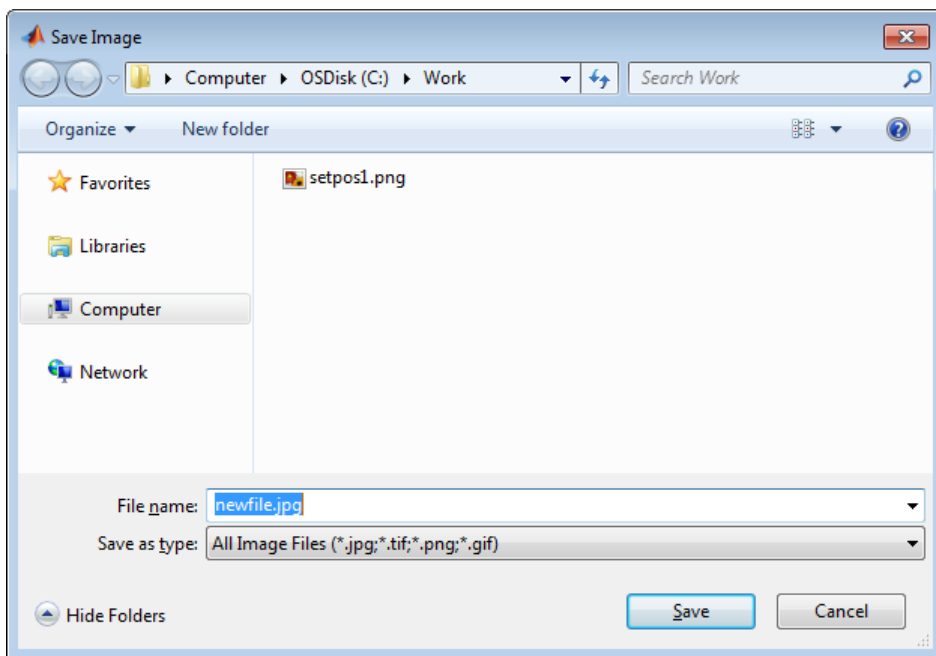

## See Also

save | uigetdir | uigetfile | uisave

# uiresume

---

<b>Purpose</b>	Resume execution of blocked program
<b>Syntax</b>	<code>uiresume(h)</code>
<b>Description</b>	<code>uiresume(h)</code> resumes the program execution that <code>uiwait</code> suspended.

**Tips**

The `uiwait` and `uiresume` functions block and resume MATLAB program execution. When creating a dialog box, you should have a `uicontrol` component with a callback that calls `uiresume` or a callback that destroys the dialog box. These are the only methods that resume program execution after the `uiwait` function blocks execution.

When used in conjunction with a modal dialog box, `uiresume` can resume the execution of the program that `uiwait` suspended while presenting a dialog box.

**Examples**

This example creates a GUI with a **Continue** push button. The example calls `uiwait` to block MATLAB execution until `uiresume` is called. This happens when the user clicks the **Continue** push button because the push button's `Callback`, which responds to the click, calls `uiresume`.

```
f = figure;
h = uicontrol('Position',[20 20 200 40],'String','Continue',...
 'Callback','uiresume(gcf)');
disp('This will print immediately');
uiwait(gcf);
disp('This will print after you click Continue');
close(f);
```

`gcbf` is the handle of the figure that contains the object whose callback is executing.

“Modal Dialog Box in a GUIDE GUI” is a more complex example for a GUIDE GUI.

**See Also** `dialog` | `figure` | `uicontrol` | `uimenu` | `uiwait` | `waitfor`

---

<b>Purpose</b>	Interactively save workspace variables to MAT-file
<b>Syntax</b>	<pre>uisave uisave(variables) uisave(variables,filename)</pre>
<b>Description</b>	<p>uisave, with no arguments, prompts you for a file name, and then saves all variables from your workspace to that file.</p> <p>uisave(variables) saves one or more workspace variables listed in variables.</p> <p>uisave(variables,filename) uses the specified filename as the default <b>File name</b> in the Save Workspace Variables dialog box, instead of the default matlab.mat.</p>
<b>Tips</b>	<ul style="list-style-type: none"><li>• If you type a name in the <b>File name</b> field, such as my_vars, and click <b>Save</b>, the dialog saves all workspace variables to the file my_vars.mat. The default filename is matlab.mat.</li><li>• uisave calls uiputfile to choose a filename.</li><li>• If the filename you specify exists in that folder, uisave informs you and gives you a chance to cancel the operation.</li><li>• The uisave dialog box is modal.</li><li>• The uisave dialog is modal. A modal dialog box prevents you from interacting with other windows until you respond to it.</li></ul>
<b>Input Arguments</b>	<p><b>variable</b></p> <p>String containing the name of a variable in the current workspace or cell array of strings when specifying more than one variable.</p> <p><b>Default:</b> All variables in the current workspace are saved to a MAT-file.</p> <p><b>filename</b></p>

String naming a file to appear in the dialog **File name** field when the dialog opens. You can omit a file extension, or specify the file extension as `.mat`.

**Default:** `matlab.mat`

## Definitions

### Modal Dialog

A modal dialog box prevents the user from interacting with other windows before responding. For more information, see `WindowState` in the MATLAB Figure Properties.

## Examples

Create workspace variables `h` and `g`, and then display the Save Workspace Variables dialog box in the current folder with the default **File name** set to `var1`.

```
h = 365;
g = 52;
uisave({'h', 'g'}, 'var1');
```

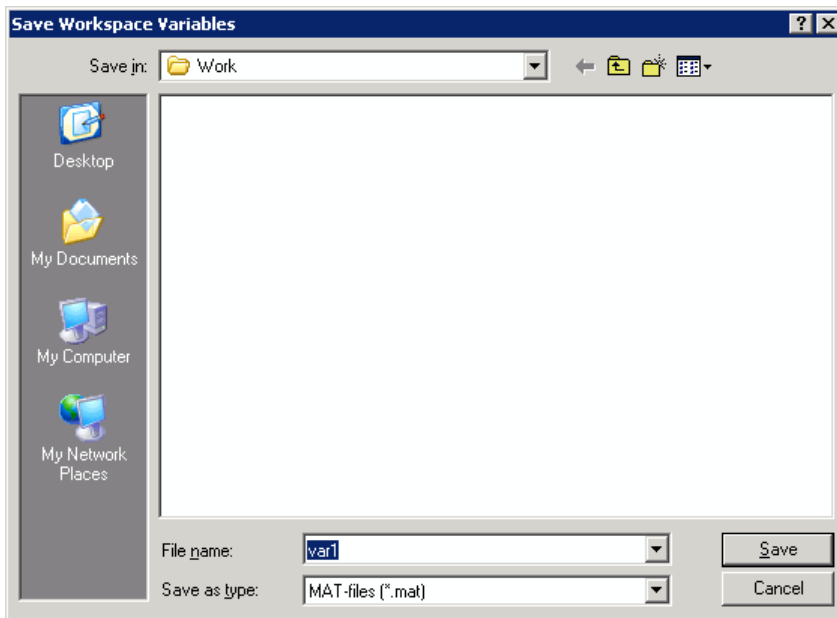

Clicking **Save** stores the workspace variables `h` and `g` in the file `var1.mat` in the displayed folder.

## Alternatives

Use any of the following GUI options to save workspace variables:

- Use **File > Save** to save workspace variables.
- Click the Save icon  in the Workspace Browser.
- Select one or more variables in the Workspace Browser, right-click, and choose **Save as** from the context menu.

## See Also

`save` | `uigetfile` | `uiputfile` | `uiopen`

## Tutorials

- “Save, Load, and Delete Workspace Variables”

# uicolor

---

**Purpose** Open standard dialog box for setting object's color specification (ColorSpec)

**Syntax**

```
c = uicolor
c = uicolor([r g b])
c = uicolor(h)
c = uicolor(..., 'dialogTitle')
```

**Description**

`c = uicolor` displays a modal color selection dialog appropriate to the platform, and returns the color selected by the user. The dialog box is initialized to white.

`c = uicolor([r g b])` displays a dialog box initialized to the specified color, and returns the color selected by the user. `r`, `g`, and `b` must be values between 0 and 1.

`c = uicolor(h)` displays a dialog box initialized to the color of the object specified by handle `h`, returns the color selected by the user, and applies it to the object. `h` must be the handle to an object containing a color property.

`c = uicolor(..., 'dialogTitle')` displays a dialog box with the specified title.

If the user presses **Cancel** from the dialog box, or if any error occurs, the output value is set to the input RGB triple, if provided; otherwise, it is set to 0.

---

**Note** A modal dialog box prevents the user from interacting with other windows before responding. For more information, see `WindowState` in the MATLAB Figure Properties.

---

**See Also** ColorSpec



**Purpose** Open standard dialog box for setting object's font characteristics

**Syntax**

```
uifont
uifont(h)
uifont(S)
uifont(..., 'DialogTitle')
S = uifont(...)
```

**Description** `uifont` enables you to change font properties (`FontName`, `FontUnits`, `FontSize`, `FontWeight`, and `FontAngle`) for a `text`, `axes`, or `uicontrol` object. The function returns a structure consisting of font properties and values. You can specify an alternate title for the dialog box.

`uifont` displays a modal dialog box and returns the selected font properties.

---

**Note** A modal dialog box prevents the user from interacting with other windows before responding. For more information, see `WindowState` in the MATLAB Figure Properties.

---

`uifont(h)` displays a modal dialog box, initializing the font property values with the values of those properties for the object whose handle is `h`. Selected font property values are applied to the current object. If a second argument is supplied, it specifies a name for the dialog box.

`uifont(S)` displays a modal dialog box, initializing the font property values with the values defined for the specified structure (`S`). `S` must define legal values for one or more of these properties: `FontName`, `FontUnits`, `FontSize`, `FontWeight`, and `FontAngle` and the field names must match the property names exactly. If other properties are defined, they are ignored. If a second argument is supplied, it specifies a name for the dialog box.

`uifont(..., 'DialogTitle')` displays a modal dialog box with the title `DialogTitle` and returns the values of the font properties selected in the dialog box.

`S = uifont(...)` returns the properties `FontName`, `FontUnits`, `FontSize`, `FontWeight`, and `FontAngle` as fields in a structure. If the user presses **Cancel** from the dialog box or if an error occurs, the output value is set to 0.

## Examples

These statements create a text object, then display a dialog box (labeled Update Font) that enables you to change the font characteristics:

```
h = text(.5,.5,'Figure Annotation');
uifont(h, 'Update Font')
```

These statements create two push buttons, then set the font properties of one based on the values set for the other:

```
% Create push button with string ABC
c1 = uicontrol('Style', 'pushbutton', ...
 'Position', [10 10 100 20], 'String', 'ABC');
% Create push button with string XYZ
c2 = uicontrol('Style', 'pushbutton', ...
 'Position', [10 50 100 20], 'String', 'XYZ');
% Display set font dialog box for c1, make selections,
& and save to d
d = uifont(c1);
% Apply those settings to c2
set(c2, d)
```

## See Also

[axes](#) | [text](#) | [uicontrol](#)

**Purpose** Manage preferences used in `uisetpref`

**Syntax** `uisetpref('clearall')`

**Description** `uisetpref('clearall')` resets the value of all preferences registered through `uisetpref` to 'ask'. This causes the dialog box to display when you call `uisetpref`.

---

**Note** Use `setpref` to set the value of a particular preference to 'ask'.

---

**See Also** `setpref` | `uisetpref`

# uistack

---

**Purpose** Reorder visual stacking order of objects

**Syntax**  
`uistack(h)`  
`uistack(h,stackopt)`  
`uistack(h,stackopt,step)`

**Description** `uistack(h)` raises the visual stacking order of the objects specified by the handles in `h` by one level (step of 1). All handles in `h` must have the same parent.

`uistack(h,stackopt)` moves the objects specified by `h` in the stacking order, where `stackopt` is one of the following:

- 'up' – moves `h` up one position in the stacking order
- 'down' – moves `h` down one position in the stacking order
- 'top' – moves `h` to the top of the current stack
- 'bottom' – moves `h` to the bottom of the current stack

`uistack(h,stackopt,step)` moves the objects specified by `h` up or down the number of levels specified by `step`.

---

**Note** In a GUI, axes objects are always at a lower level than `uicontrol` objects. You cannot stack an axes object on top of a `uicontrol` object.

---

See “Set Tab Order in a Programmatic GUI” in the MATLAB documentation for information about changing the tab order.

**Examples** Create three stacked push buttons, and then use `uistack` to change the stacking order. Initially, the Ready push button appears on top.

```
fh=figure;
pb1 = uicontrol('Parent', fh,'String','Go');
pb2 = uicontrol('Parent', fh,'String','Set');
pb3 = uicontrol('Parent', fh,'String','Ready');
```

Use `uistack` to move the push button that is first in the stacking order of the figure handle `fh` down two positions.

```
v = allchild(fh);
uistack(v(1), 'down', 2);
```

The Ready push button moves to the bottom of the stack.

# uitable

---

**Purpose** Create 2-D graphic table GUI component

**Syntax**

```
uitable
uitable('PropertyName1', value1, 'PropertyName2', value2, ...)
uitable(parent, ...)
handle = uitable(...)
```

**Description** `uitable` creates an empty `uitable` object in the current figure window, using default property values. If no figure exists, a new figure window opens.

`uitable('PropertyName1', value1, 'PropertyName2', value2, ...)` creates a `uitable` object with specified property values. Properties that you do not specify assume the default property values. See the `Uitable Properties` reference page for information about the available properties.

`uitable(parent, ...)` creates a `uitable` object as a child of the specified parent handle `parent`. The parent can be a figure or `uipanel` handle. If you also specify a different value for the `Parent` property, the value of the `Parent` property takes precedence.

`handle = uitable(...)` creates a `uitable` object and returns its handle.

**Tips** After creating a `uitable` object, you can set and query its property values using the `set` and `get` functions.

If the `ColumnEditable` property is `true` for columns you edit, you can change values in a displayed table. By default, this property is `false` for all columns. If a noneditable column contains pop-up choices, only the current choice is visible (and not the pop-up menu control).

If you attempt to create a `uitable` object when running MATLAB on a UNIX system without a Java virtual machine (`matlab -nojvm`) or without a display (`matlab nodisplay`), no table generates and you receive an error.

The **`CellEditCallback`** executes after you edit a value and do any of the following:

- Type **Enter**.
- Click another table cell.
- Click anywhere else within the table.
- Click another control or area within the same figure window.
- Click another window, click again on the GUI containing the table (or use **Alt+Tab** to switch windows), and then perform any of the above four actions.

When the `CellEditCallback` callback executes, `uitable` updates the underlying data matrix (the table `Data` property) to contain the value that the cell now displays.

The `CellSelectionCallback` executes when you select a table cell or remove one from the current selection by **Ctrl**+clicking it. Clicking a cell without pressing any key selects it and deselects all currently selected cells. You can define a range of table cells by **Shift**+clicking an unselected cell after selecting one or more cells. The callback provides event data that identifies the rows and columns of all cells in the current selection.

You cannot select table cells programmatically. Directly clicking cells is the only method of selection.

## Examples

Create a table, provide magic-square data, set column widths uniformly, and specify the `uitable` `ColumnWidth` property as a cell array:

- 1 Create a table in the current figure. If no figure exists, one opens:

```
t = uitable;
```

# uitable

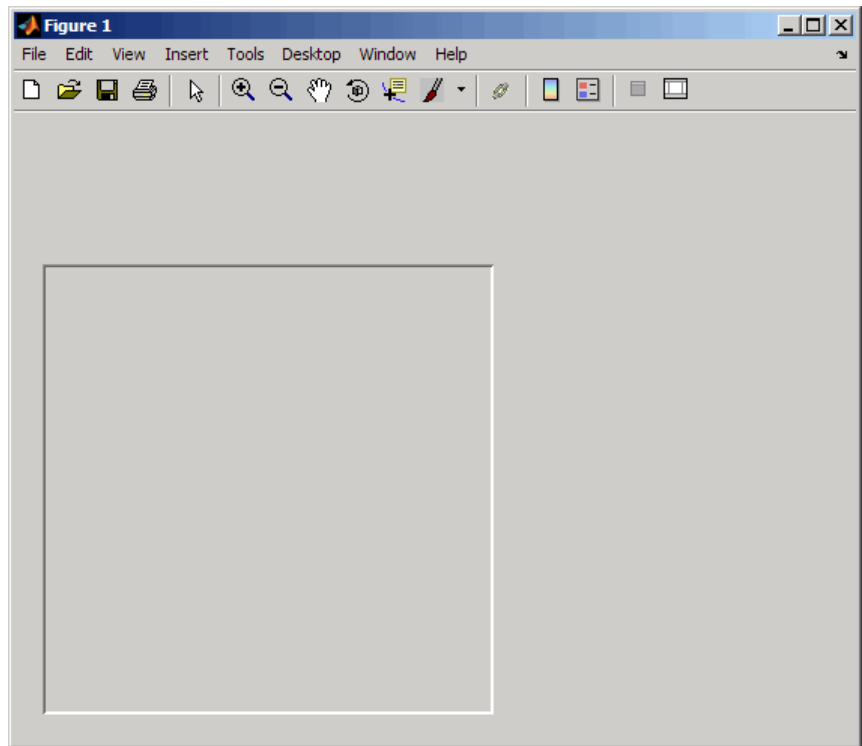

- 2** As the table has no content (its Data property is empty), it initially displays no rows or columns. Provide data (a magic square)

```
set(t,'Data',magic(10))
```



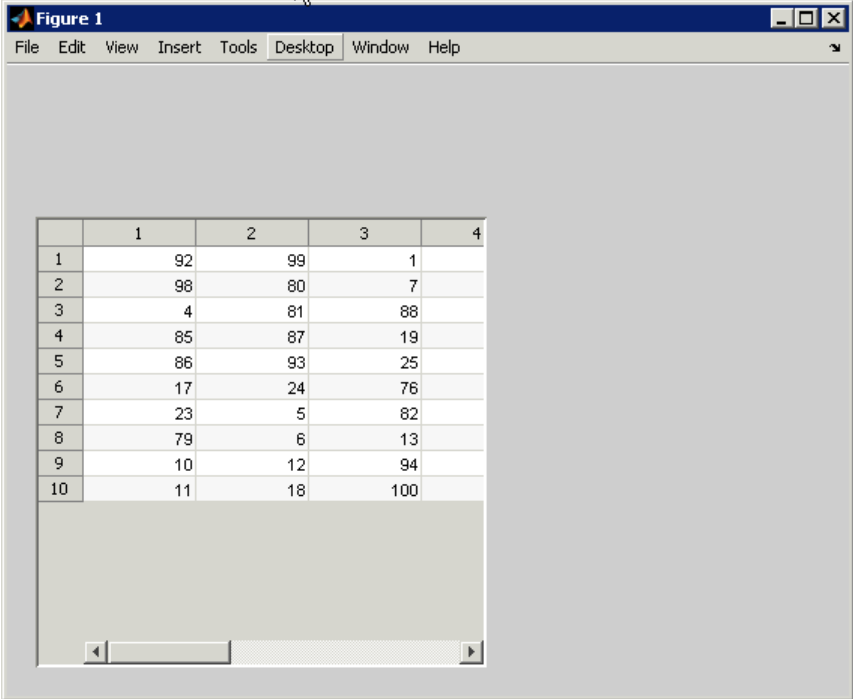

	1	2	3	4
1	92	99	1	
2	98	80	7	
3	4	81	88	
4	85	87	19	
5	86	93	25	
6	17	24	76	
7	23	5	82	
8	79	6	13	
9	10	12	94	
10	11	18	100	

- 3** Make the entire table contents visible. Set column widths to 25 pixels uniformly. Specify the `ColumnWidth` property of the table as a cell array.

```
set(t, 'ColumnWidth', {25})
```

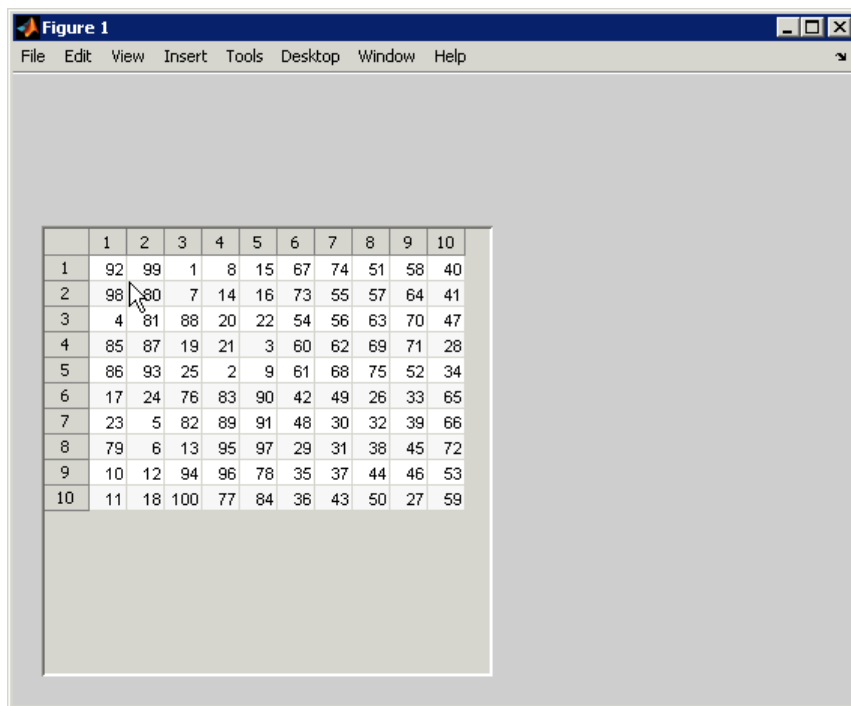

Cell arrays that specify `ColumnWidth` can contain:

- One number (a width measured in pixels, as shown here) or the string 'auto'.
- A cell array containing a list of pixel sizes having up to as many entries as the table has columns .

If a list of column widths has  $n$  entries, where  $n$  is smaller than the number of columns, it sets the first  $n$  column widths only. You can substitute 'auto' for any value in the cell array to have the width of that column calculated automatically.

Create a figure and add a table to contain a 3-by-3 data matrix. The code specifies the column names, row names, parent, and position of the table:

```
f = figure('Position',[200 200 400 150]);
dat = rand(3);
cnames = {'X-Data','Y-Data','Z-Data'};
rnames = {'First','Second','Third'};
t = uitable('Parent',f,'Data',dat,'ColumnName',cnames,...
 'RowName',rnames,'Position',[20 20 360 100]);
```

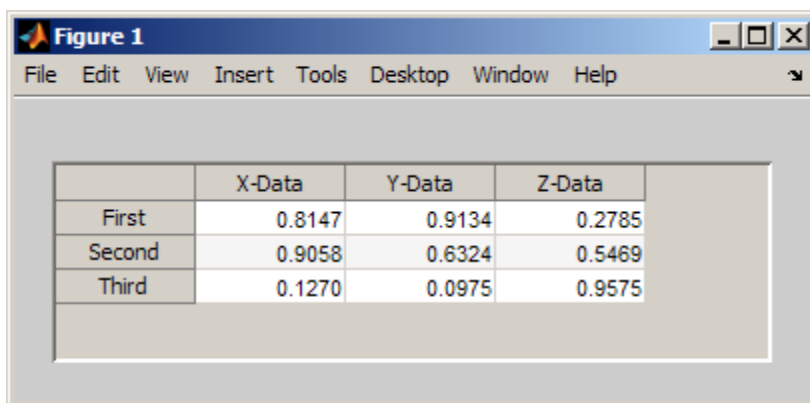

Create a table to contain a 3-by-4 array that contains numeric, logical, and string data, as follows:

- First column (**Rate**): Numeric, with three decimals (not editable)
- Second column (**Amount**): Currency (not editable)
- Third column (**Available**): Check box (editable)
- Fourth column (**Fixed/Adj**): Pop-up menu with two choices: Fixed and Adjustable (editable)
- Specify the RowName property as empty to remove row names from the table.

```
f = figure('Position',[100 100 400 150]);
```

# uitable

```
dat = {6.125, 456.3457, true, 'Fixed';...
 6.75, 510.2342, false, 'Adjustable';...
 7, 658.2, false, 'Fixed'}};
columnname = {'Rate', 'Amount', 'Available', 'Fixed/Adj'};
columnformat = {'numeric', 'bank', 'logical', {'Fixed' 'Adjustable'}};
columneditable = [false false true true];
t = uitable('Units','normalized','Position',...
 [0.1 0.1 0.9 0.9], 'Data', dat,...
 'ColumnName', columnname,...
 'ColumnFormat', columnformat,...
 'ColumnEditable', columneditable,...
 'RowName', []);
```

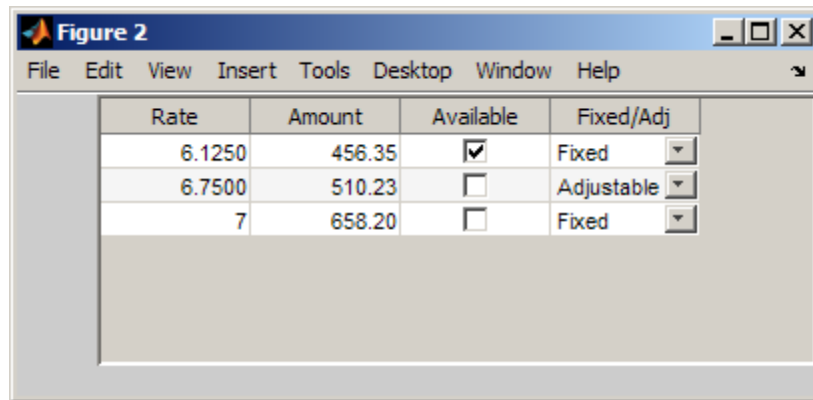

## Alternatives

You can add tables to GUIs you create with “Table”.

## See Also

`figure` | `format` | `get` | `set` | `uipanel` | Uitable Properties

## Tutorials

- “Synchronized Data Presentations in a GUIDE GUI”
- “Synchronized Data Presentations in a Programmatic GUI”

## How To

- “Table”

## Purpose

Describe table properties

## Modifying Properties

You can set and query graphics object properties in two ways:

- The Property Inspector is an interactive tool that enables you to see and change object property values. The Property inspector is available from the GUIDE Layout Editor **View** menu, or use the `inspect` function at the command line.
- The `set` and `get` functions enable you to set and query the values of properties.

You can set default uitable properties by typing:

```
set(h, 'DefaultUitablePropertyName', PropertyValue...)
```

Where `h` can be the root handle (0), a figure handle, or a uitable handle. *PropertyName* is the name of the uitable property and *PropertyValue* is the value you specify as the default for that property.

For more information about changing the default value of a property see “Setting Default Property Values”. For an example, see the `CreateFcn` property.

## Uitable Properties

This section lists all properties useful to uitable objects along with valid values and descriptions of their use. In the property descriptions, curly braces { } enclose default values.

Property Name	Description
<code>BackgroundColor</code>	Background color of cells.
<code>BeingDeleted</code>	This object is being deleted.
<code>BusyAction</code>	Callback routine interruption
<code>ButtonDownFcn</code>	Button-press callback routine
<code>CellEditCallback</code>	Callback when data in a cell is changed.

# Uitable Properties

---

Property Name	Description
CellSelectionCallback	Callback when cell is selected
Children	uitable objects have no children
Clipping	Does not apply to uitable objects
ColumnEditable	Determines data in a column as editable
ColumnFormat	Determines display and editability of columns
ColumnName	Column header label
ColumnWidth	Width of each column in pixels
CreateFcn	Callback routine during object creation
Data	Table data
DeleteFcn	Callback routine during object deletion
Enable	Enable or disable the uitable
Extent	Size of uitable rectangle
FontAngle	Character slant of cell content
FontName	Font family for cell content
FontSize	Font size of cell content
FontUnits	Font size units for cell content
FontWeight	Weight of cell text characters
ForegroundColor	Color of text in cells
HandleVisibility	Control access to object's handle
Interruptible	Callback routine interruption mode
KeyPressFcn	Key press callback function
Parent	uitable parent

Property Name	Description
Position	Size and location of uitable
RearrangeableColumns	Location of the column
RowName	Row header label names
RowStriping	Color striping of label rows
Tag	Use-specified object label
TooltipString	Content of tooltip for object
Type	Class of graphics object
UIContextMenu	Associate context menu with uitable
Units	Units of measurement
UserData	User-specified data
Visible	uitable visibility

## BackgroundColor

1-by-3 or 2-by-3 matrix of RGB triples

*Cell background color.* Color used to fill the uitable cells. Specify as an 1-by-3 or 2-by-3 matrix of RGB triples, such as [ .8 .9 .8] or [1 1 .9; .9 1 1]. Each row is an RGB triplet of real numbers between 0.0 and 1.0 that defines one color. (Color names are not allowed.) The default is a 1-by-3 matrix of platform-dependent colors. See ColorSpec for information about RGB colors.

Row 2 of the matrix is used only if the RowStriping property is on. The table background is not striped unless both RowStriping is on and the BackgroundColor color matrix has two rows.

# Uitable Properties

---

## BeingDeleted

on | {off} (read-only)

*This object is being deleted.* The `BeingDeleted` property provides a mechanism that you can use to determine if objects are in the process of being deleted. MATLAB software sets the `BeingDeleted` property to on when the object's delete function callback is called (see the `DeleteFcn` property) It remains set to on while the delete function executes, after which the object no longer exists.

For example, some functions may not need to perform actions on objects that are being deleted, and therefore, can check the object's `BeingDeleted` property before acting.

## BusyAction

cancel | {queue}

### *Callback queuing*

Determines how MATLAB handles the execution of interrupting callbacks.

A *running* callback is the currently executing callback. The *interrupting* callback is the callback that tries to interrupt the *running* callback. The `BusyAction` property of the *interrupting* callback determines how MATLAB handles its execution. When the `BusyAction` property is set to:

- 'queue' — Puts the *interrupting* callback in a queue to be processed after the *running* callback finishes execution.
- 'cancel' — Discards the *interrupting* callback as MATLAB finishes execution.

For information about how the `Interruptible` property of the callback controls whether other callbacks can interrupt the *running* callback, see the `Interruptible` property description.



## ButtonDownFcn

string or function handle (GUIDE sets this property)

*Button-press callback routine.* A callback routine that can execute when you press a mouse button while the pointer is on or near a `uitable`. Specifically:

- If the `uitable` `Enable` property is set to on, the `ButtonDownFcn` callback executes when you click the right or left mouse button in a 5-pixel border around the `uitable` or when you click the right mouse button on the control itself.
- If the `uitable` `Enable` property is set to inactive or off, the `ButtonDownFcn` executes when you click the right or left mouse button in the 5-pixel border or on the control itself.

This is useful for implementing actions to interactively modify control object properties, such as size and position, when they are clicked on.

Define this routine as a string that is a valid MATLAB expression or the name of a MATLAB function file. The expression executes in the MATLAB workspace.

To add a `ButtonDownFcn` callback in GUIDE, select **View Callbacks** from the Layout Editor **View** menu, then select `ButtonDownFcn`. GUIDE sets this property to the appropriate string and adds the callback to the program file the next time you save the GUI. Alternatively, you can set this property to the string `%automatic`. The next time you save the GUI, GUIDE sets this property to the appropriate string and adds the callback to the program file.

## CellEditCallback

function handle, cell array containing function handle and additional arguments, or string (not recommended)

*Callback to edit user-entered data*

# Uitable Properties

---

Callback function executed when the user modifies a table cell. It can perform evaluations, validations, or other customizations. If this function is called as a function handle, `uitable` passes it two arguments. The first argument, `source`, is the handle of the `uitable`. The second argument, `eventdata`, is an event data structure that contains the fields shown in the following table. All fields in the event data structure are read only.

Event Data Structure Field	Type	Description
Indices	1-by-2 matrix	Row index and column index of the cell the user edited.
PreviousData	1-by-1 matrix or cell array	Previous data for the changed cell. The default is an empty matrix, <code>[]</code> .
EditData	String	User-entered string.
NewData	1-by-1 matrix or cell array	Value that <code>uitable</code> wrote to <code>Data</code> . It is either the same as <code>EditData</code> or a converted value, for example, <code>2</code> where <code>EditData</code> is <code>'2'</code> and the cell is numeric.  Empty if <code>uitable</code> detected an error in the user-entered data and did not write it to <code>Data</code> .
Error	String	Error that occurred when <code>uitable</code> tried to convert the <code>EditData</code> string into a value appropriate for <code>Data</code> . For example, <code>uitable</code> could not convert the <code>EditData</code> string consistent with the <code>Column Format</code> property, if any, or the data type for the changed cell.  Empty if <code>uitable</code> wrote the value to <code>Data</code> .

Event Data Structure Field	Type	Description
		If Error is not empty, the <code>CellEditCallback</code> can pass the error string to the user or can attempt to manipulate the data. For example, the string 'pi' would raise an error in a numeric cell but the <code>CellEditCallback</code> could convert it to its numerical equivalent and store it in <code>Data</code> without passing the error to the user.

When a user edits a cell, `uitable` first attempts to store the user-entered value in `Data`, converting the value if necessary. It then calls the `CellEditCallback` and passes it the event data structure. If there is no `CellEditCallback` and the user-entered data results in an error, the contents of the cell reverts to its previous value and no error is displayed. The `CellEditCallback` is issued when the user has modified a table cell and presses **Enter** or clicks anywhere outside the cell.

#### `CellSelectionCallback`

function handle, cell array containing function handle and additional arguments, or string (not recommended)

*Callback that executes when cell is selected.* Callback function that executes when the user highlights a cell by navigating to it or clicking it. For multiple selection, this callback executes when new cells are added to the selection. The callback includes event data, a structure with one member

# Uitable Properties

---

Event Data Structure Field	Type	Description
Indices	n-by-2 matrix	Row index and column index of the cells the user currently has selected

Once a cell selection has been made, cells within it can be removed one at a time by **Ctrl**-clicking them.

Children  
matrix

The empty matrix; `uitable` objects have no children.

Clipping  
{on} | off

This property has no effect on `uitable` objects.

ColumnEditable  
logical 1-by-n matrix | scalar logical value | {empty matrix ([ ])}

*Determines if column is user-editable.*

Determines if the data can be edited by the end user. Each value in the cell array corresponds to a column. `false` is default because the developer needs to have control over changes users potentially might make to data.

Specify elements of a logical matrix as `true` if the data in a column is editable by the user or `false` if it is not. An empty matrix indicates that no columns are editable.

Columns that contain check boxes or pop-up menus must be editable for the user to manipulate these controls. If a column that contains pop-up menus is not editable, the currently selected choice appears without displaying the pop-up control. The

Elements of the `ColumnEditable` matrix must be in the same order as columns in the `Data` property. If you do not specify `ColumnEditable`, the default is an empty matrix (`[]`).

## `ColumnFormat`

cell array of strings

*Cell display formatting.* Determines how the data in each column displays and is edited. Elements of the cell array must be in the same order as table columns in the `Data` property. If you do not want to specify a display format for a particular column, enter `[]` as a placeholder. If no format is specified for a column, the default display is determined by the data type of the data in the cell. Default `ColumnFormat` is an empty cell array (`{}`). In most cases, the default is similar to the command window.

Elements of the cell array must be one of the strings described in the following table.

Cell Format	Description
'char'	Displays a left-aligned string. To edit, the user types a string that replaces the existing string.
'logical'	Displays a check box. To edit, the user checks or unchecks the check box. <code>uitable</code> sets the corresponding <code>Data</code> value to <code>true</code> or <code>false</code> accordingly. Initially, the check box is checked if the corresponding <code>Data</code> value would produce <code>true</code> if passed to the <code>logical</code> function, and unchecked otherwise.

# Uitable Properties

---

Cell Format	Description
'numeric'	<p>Displays a right-aligned string equivalent to the command window, for numeric data. If the cell Data value is boolean, then 1 or 0 is displayed. If the cell Data value is not numeric and not boolean, then NaN is displayed.</p> <p>To edit, the user can enter any string. This enables a user to enter a value such as 'pi' that can be converted to its numeric equivalent by a <code>CellEditCallback</code>. The <code>uitable</code> function first attempts to convert the user-entered string to a numeric value and store it in <code>Data</code>. It then calls the <code>CellEditCallback</code>. See <code>CellEditCallback</code> for more information.</p>
1-by-n cell array of strings that define a pop-up menu, e.g., {'one' 'two' 'three'}	<p>Displays a pop-up menu.</p> <p>To edit, the user makes a selection from the pop-up menu. <code>uitable</code> sets the corresponding <code>Data</code> value to the selected menu item.</p> <p>The initial values for the pop-up menus in the column are the corresponding strings in <code>Data</code>. These initial values do not have to be items in the pop-up menu. See Example 3 on the <code>uitable</code> reference page.</p>
Valid string accepted by the format function, e.g., 'short' or 'bank'	<p>Displays the <code>Data</code> value using the specified format. For example, for a two-column table, <code>set(htable, 'ColumnFormat', {'short', 'bank'})</code>.</p>

In some cases, you may need to insert an appropriate column in Data. If Data is a numerical or logical matrix, you must first convert it to a cell array using the `mat2cell` function.

## Data and ColumnFormat

When you create a table, you must specify value of Data. The Data property dictates what type of data can exist in any given cell. By default, the value of the Data also dictates the display of the cell to the end user, unless you specify a different format using the ColumnFormat property.

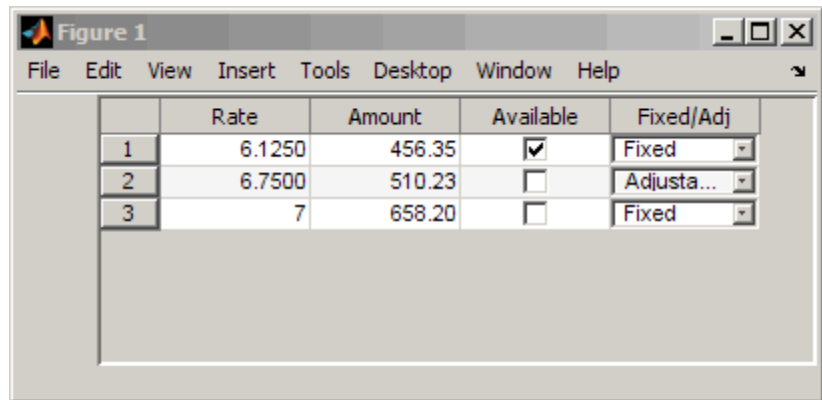

	Rate	Amount	Available	Fixed/Adj
1	6.1250	456.35	<input checked="" type="checkbox"/>	Fixed
2	6.7500	510.23	<input type="checkbox"/>	Adjusta...
3	7	658.20	<input type="checkbox"/>	Fixed

ColumnFormat controls the presentation of the Data to the end user. Therefore, if you specify a ColumnFormat of `char` (or pick **Text** from the Table Property Editor), you are asking the table to display the Data associated with that column as a string. For example, if the Data for a particular column is numeric, and you specify the ColumnFormat as `char`, then the display of the numeric data will be left-aligned

# Uitable Properties

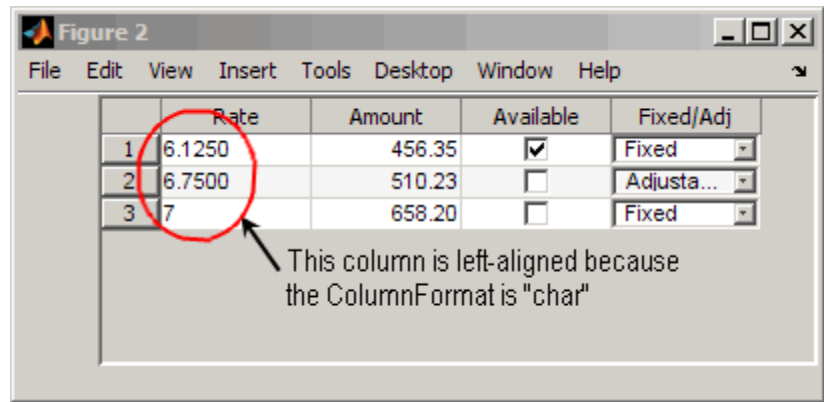

If your column is editable and the user enters a number, the number will be left-aligned. However, if the user enters a text string, the table displays a NaN.

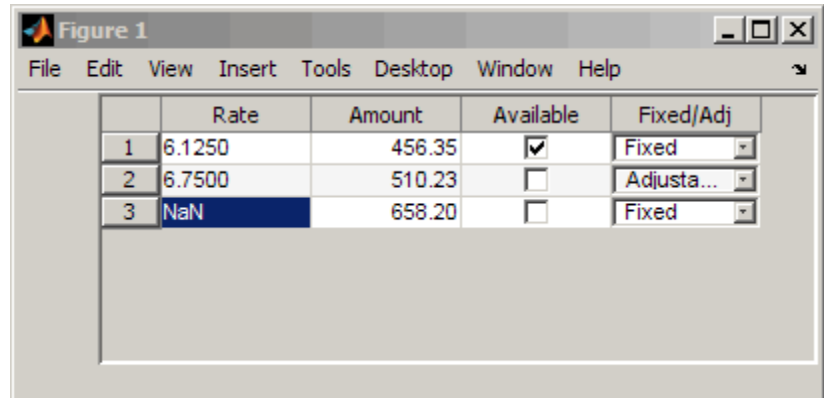

Another possible scenario is that the value Data is char and you set the ColumnFormat to be a pop-up menu. Here, if the value of the Data in the cell matches one of the pop-up menu choices you define in ColumnFormat, then the Data is shown in the cell. If it does not match, then the cell defaults to display the first option from the choices you specify in ColumnFormat. Similarly, if Data



is numeric or logical with the ColumnFormat as pop-up menu, if the Data value in the cell does not match any of the choices you specify in ColumnFormat, the cell defaults to display the first option in the pop-menu choice.

This table describes how Data values correspond with your ColumnFormat when the columns are editable.

		ColumnFormat Selections		
		numeric	char	logical
Data Type	numeric	Values match. MATLAB displays numbers as is.	MATLAB converts the text string entered to a double. See <code>str2double</code> for more information. If string cannot be converted, <code>NaN</code> is displayed.	Does not work: warning is thrown. <hr/> <b>Note</b> If you have defined <code>CellEditCallback</code> , this warning will not be thrown
	char	MATLAB converts the entered number to a text string.	Values match. MATLAB displays the string as is.	Does not work: warning is thrown. <hr/> <b>Note</b> If you have defined <code>CellEditCallback</code> , this warning will not be thrown
	logical	Does not work: warning is thrown.	If text string entered is true	Values match. MATLAB displays

# Uitable Properties

		<hr/> <p><b>Note</b> If you have defined <code>CellEditCallback</code>, this warning will not be thrown</p> <hr/>	<p>or <code>false</code>, MATLAB converts string to the corresponding logical value and displays it. For all others, it Does not work: warning is thrown.</p> <hr/> <p><b>Note</b> If you have defined <code>CellEditCallback</code>, this warning will not be thrown</p> <hr/>	<p>logical value as a check box as is.</p>
--	--	-------------------------------------------------------------------------------------------------------------------	---------------------------------------------------------------------------------------------------------------------------------------------------------------------------------------------------------------------------------------------------------------------------------	--------------------------------------------

If you get a mismatch error, you have the following options:

- Change the `ColumnFormat` or value of `Data` to match.
- Implement the `CellEditCallback` to handle custom data conversion.

## ColumnName

*n*-by-1 cell array of strings | 1-by-*n* cell array of strings | {'numbered'} | empty matrix ([])

*Column heading names.* Each element of the cell array is the name of a column. Multiline column names can be expressed as a string vector separated by vertical slash (|) characters, e.g., 'Standard|Deviation'

For sequentially numbered column headings starting with 1, specify `ColumnName` as 'numbered'. This is the default.

To remove the column headings, specify `ColumnName` as the empty matrix ( []).

The number of columns in the table is the larger of `ColumnName` and the number of columns in the `Data` property matrix or cell array.

If you specify the `ColumnName` value as a 1-by- $n$  cell array of strings, MATLAB stores and returns the value as a  $n$ -by-1 cell array of strings.

## ColumnWidth

1-by- $n$  cell array | 'auto'

*Column widths.* The width of each column in units of pixels. Column widths are always specified in pixels; they do not obey the `Units` property. Each column in the cell array corresponds to a column in the uitable. By default, the width of the column name, as specified in `ColumnName`, along with some other factors, is used to determine the width of a column. If `ColumnWidth` is a cell array and the width of a column is set to 'auto' or if **auto** is selected for that column in the Property Inspector GUI for columns, the column width defaults to a size determined by the table. The table decides the default size using a number of factors, including the `ColumnName` and the minimum column size.

To default all column widths in an existing table, use

```
set(uitable_handle, 'ColumnWidth', 'auto')
```

To default some column widths but not others, use a cell array containing a mixture of pixel values and 'auto'. For example,

```
set(uitable_handle, 'ColumnWidth', {64 'auto' 40 40 'auto' 72})
```

## CreateFcn

string or function handle

*Callback routine executed during object creation.* The specified function executes when MATLAB creates a uitable object. MATLAB sets all property values for the uitable before executing

# Uitable Properties

---

the `CreateFcn` callback so these values are available to the callback. Within the function, use `gcbo` to get the handle of the uitable being created.

Setting this property on an existing uitable object has no effect.

You can define a default `CreateFcn` callback for all new uitables. This default applies unless you override it by specifying a different `CreateFcn` callback when you call `uitable`. For example, the code

```
set(0,'DefaultUitableCreateFcn','set(gcbo,...
 'BackgroundColor','blue'))
```

creates a default `CreateFcn` callback that runs whenever you create a new uitable. It sets the default background color of all new uitables.

To override this default and create a uitable whose `BackgroundColor` is set to a different value, call `uitable` with code similar to

```
hpt = uitable(...,'CreateFcn','set(gcbo,...
 'BackgroundColor','white'))
```

---

**Note** To override a default `CreateFcn` callback you must provide a new callback and not just provide different values for the specified properties. This is because the `CreateFcn` callback runs after the property values are set, and can override property values you have set explicitly in the `uitable` call. In the example above, if instead of redefining the `CreateFcn` property for this uitable, you had explicitly set `BackgroundColor` to `white`, the default `CreateFcn` callback would have set `BackgroundColor` back to the default, i.e., `blue`.

---

Do not call `copyobj` or `textwrap` (which calls `copyobj`) inside a `CreateFcn`. The act of copying the uicontrol object fires the

CreateFcn repeatedly, which raises a series of error messages after exceeding the root object's RecursionLimit property.

See “Function Handle Callbacks” for information on how to use function handles to define a callback function.

## Data

matrix or cell array of numeric, logical, or character data

*Data content of uitable.* The matrix or cell array must be 2-dimensional. A cell array can mix data types.

Use `get` and `set` to modify Data. For example,

```
data = get(tablehandle, 'Data')
data(event.indices(1), event.indices(2)) = pi();
set(tablehandle, 'Data', data);
```

See `CellEditCallback` for information about the event data structure. See `ColumnFormat` for information about specifying the data display format.

The number of rows in the table is the larger of `RowName` and the number of rows in `Data`. The number of columns in the table is the larger of `ColumnName` and the number of columns in `Data`.

## DeleteFcn

string or function handle

*Delete uitable callback routine.* A callback routine that executes when you delete the `uitable` object (e.g., when you issue a `delete` command or `clear` the figure containing the `uitable`). MATLAB executes the routine before destroying the object's properties so these values are available to the callback routine.

The handle of the object whose `DeleteFcn` is being executed is accessible only through the root `CallbackObject` property, which you can query using `gcbo`.

# Uitable Properties

---

See “Function Handle Callbacks” for information on how to use function handles to define a callback function.

**Enable**

{on} | inactive | off

*Enable or disable the uitable.* This property determines how uitables respond to mouse button clicks, including which callback routines execute.

- **on** – The uitable is operational (the default).
- **inactive** – The uitable is not operational, but looks the same as when **Enable** is on.
- **off** – The uitable is not operational and its image is grayed out.

When you left-click on a uitable whose **Enable** property is on, MATLAB performs these actions in this order:

- 1** Sets the figure’s **SelectionType** property.
- 2** Executes the uitable’s **CellSelectionCallback** routine (but only for table cells, not header cells). Row and column indices of the cells the user selects continuously update the **Indices** field in the **eventdata** passed to the callback.
- 3** Does not set the figure’s **CurrentPoint** property and does not execute either the table’s **ButtonDownFcn** or the figure’s **WindowButtonDownFcn** callback.

When you left-click on a uitable whose **Enable** property is **off**, or when you right-click a uitable whose **Enable** property has any value, MATLAB performs these actions in this order:

- 1** Sets the figure’s **SelectionType** property.
- 2** Sets the figure’s **CurrentPoint** property.
- 3** Executes the figure’s **WindowButtonDownFcn** callback.

## Extent

position rectangle (read only)

*Size of uitable rectangle.* A four-element vector of the form `[0,0,width,height]` that contains the calculated values of the largest extent of the table based on the current `Data`, `RowName` and `ColumnName` property values. Calculation depends on column and row widths, when they are available. The calculated extent can be larger than the figure.

The first two elements are always zero. `width` and `height` are the dimensions of the rectangle. All measurements are in units specified by the `Units` property.

When the uitable's `Units` property is set to `'Normalized'`, its `Extent` is measured relative to the figure, regardless of whether the table is contained in (parented to) a `uipanel` or not.

You can use this property to determine proper sizing for the uitable with respect to its content. Do this by setting the `width` and `height` of the uitable `Position` property to the `width` and `height` of the `Extent` property. However, doing this can cause the table to extend beyond the right or top edge of the figure and/or its `uipanel` parent, if any, for tables with large extents.

## FontAngle

{normal} | italic | oblique

*Character slant of cell content.* MATLAB uses this property to select a font from those available on your particular system. Setting this property to `italic` or `oblique` selects a slanted version of the font, when it is available on your system.

## FontName

string

*Font family for cell content.* The name of the font in which to display cell content. To display and print properly, this must

# Uitable Properties

---

be a font that your system supports. The default font is system dependent.

To use a fixed-width font that looks good in any locale (and displays properly in Japan, where multibyte character sets are used), set `FontName` to the string `FixedWidth` (this string value is case sensitive):

```
set(uitable_handle, 'FontName', 'FixedWidth')
```

This parameter value eliminates the need to hard code the name of a fixed-width font, which may not display text properly on systems that do not use ASCII character encoding (such as in Japan). A properly written MATLAB application that needs to use a fixed-width font should set `FontName` to `FixedWidth` and rely on the root `FixedWidthFontName` property to be set correctly in the end user's environment.

End users can adapt a MATLAB application to different locales or personal environments by setting the root `FixedWidthFontName` property to the appropriate value for that locale from `startup.m`. Setting the root `FixedWidthFontName` property causes an immediate update of the display to use the new font.

## FontSize

size in `FontUnits`

*Font size for cell contents.* A number specifying the size of the font in which to display cell contents, in units determined by the `FontUnits` property. The default point size is system dependent. If `FontUnits` is set to `normalized`, `FontSize` is a number between 0 and 1.

## FontUnits

{points} | normalized | inches |  
centimeters | pixels



*Font size units for cell contents.* This property determines the units used by the `FontSize` property. Normalized units interpret `FontSize` as a fraction of the height of the uitable. When you resize the uitable, MATLAB modifies the screen `FontSize` accordingly. `pixels`, `inches`, `centimeters`, and `points` are absolute units (1 point =  $1/72$  inch).

## FontWeight

`light` | `{normal}` | `demi` | `bold`

*Weight of cell text characters.* MATLAB uses this property to select a font from those available on your particular system. Setting this property to `bold` causes MATLAB to use a bold version of the font, when it is available on your system.

## ForegroundColor

1-by-3 matrix of RGB triples or a color name

*Color of text in cells.* Determines the color of the text defined for cell contents. Text in all cells share the current color. Specify as a 1-by-3 matrix of RGB triples, such as `[0 0 .8]` or as a color name. The default is a 1-by-3 matrix of platform-dependent colors. See `ColorSpec` for information about specifying RGB colors.

## HandleVisibility

`{on}` | `callback` | `off`

*Control access to object's handle.* This property determines when an object's handle is visible in its parent's list of children. When a handle is not visible in its parent's list of children, it is not returned by functions that obtain handles by searching the object hierarchy or querying handle properties. This includes `get`, `findobj`, `gca`, `gcf`, `gco`, `newplot`, `cla`, `clf`, and `close`. Neither is the handle visible in the parent figure's `CurrentObject` property. Handles that are hidden are still valid. If you know an object's handle, you can `set` and `get` its properties, and pass it to any function that operates on handles.

- Handles are always visible when `HandleVisibility` is on.

# Uitable Properties

---

- Setting `HandleVisibility` to `callback` causes handles to be visible from within callback routines or functions invoked by callback routines, but not from within functions invoked from the command line. This provides a means to protect GUIs from command-line users, while allowing callback routines to have complete access to object handles.
- Setting `HandleVisibility` to `off` makes handles invisible at all times. This may be necessary when a callback routine invokes a function that might potentially damage the GUI (such as evaluating a user-typed string), and so temporarily hides its own handles during the execution of that function.

You can set the root `ShowHiddenHandles` property to `on` to make all handles visible, regardless of their `HandleVisibility` settings. This does not affect the values of the `HandleVisibility` properties.

`HitTest`  
{on} | off

*Selectable by mouse click.* When `HitTest` is `off`, the `ButtonDownFcn` callback does not execute.

---

**Note** Use of the uitable `Hittest` property is not recommended. This property may be removed in a future release.

---

`Interruptible`  
off | {on}

*Callback routine interruption*

Controls whether MATLAB can interrupt an object's callback function when subsequent callbacks attempt to interrupt it.

For user interface objects, the `Interruptible` property affects the callbacks for these properties only:

- `ButtonDownFcn`
- `KeyPressFcn`
- `KeyReleaseFcn`
- `WindowButtonDownFcn`
- `WindowButtonMotionFcn`
- `WindowButtonUpFcn`
- `WindowKeyPressFcn`
- `WindowKeyReleaseFcn`
- `WindowScrollWheelFcn`

A *running* callback is the currently executing callback. The *interrupting* callback is the callback that tries to interrupt the *running* callback. MATLAB handles both callbacks based on the `Interruptible` property of the object of the *running* callback.

When the `Interruptible` property is set to:

- 'off', MATLAB finishes execution of the *running* callback without any interruptions
- 'on', these conditions apply:
  - If there is a `drawnow`, `figure`, `getframe`, `waitfor`, or `pause` command in the *running* callback, then MATLAB executes the *interrupting* callbacks which are already in the queue and returns to finish execution of the current callback.
  - If one of the above functions is not in the *running* callback, then MATLAB finishes execution of the current callback without any interruption.

# Uitable Properties

---

The `BusyAction` property of the object of interrupting callback determines whether the callback should be ignored or should be put in the queue.

Setting the `Interruptible` property to `on` (default), allows a callback from other user interface objects to interrupt callback functions originating from this object.

---

**Note** MATLAB does not save the state of properties or the display when an interruption occurs. For example, the handle returned by the `gca` or `gcf` command may be changed as another callback is executed.

---

After the function that interrupts a callback completes, the callback resumes execution where it halted when interrupted. For more information, see “Control Callback Execution and Interruption”.

---

**Note** If the interrupting callback is a `DeleteFcn` or `CreateFcn` callback, or a figure’s `CloseRequest` or `ResizeFcn` callback, it interrupts an executing callback regardless of the value of that object’s `Interruptible` property. The interrupting callback starts execution at the next `drawnow`, `figure`, `getframe`, `pause`, or `waitfor` statement. An object’s `ButtonDownFcn` or `Callback` routine is processed according to the rules described previously in this section.

---

`KeyPressFcn`  
string or function handle

*Key press callback function.* A callback routine invoked by a key press when the callback’s `uitable` object has focus. Focus is denoted by a border or a dotted border, respectively, in UNIX

and Microsoft Windows. If no uitable has focus, the figure's key press callback function, if any, is invoked. `KeyPressFcn` can be a function handle, the name of a MATLAB function file, or any legal MATLAB expression.

If the specified value is the name of a function code file, the callback routine can query the figure's `CurrentCharacter` property to determine what particular key was pressed and thereby limit the callback execution to specific keys.

If the specified value is a function handle, the callback routine can retrieve information about the key that was pressed from its event data structure argument.

Event Data Structure Field	Description	Examples:			
		a	=	Shift	Shift/a
Character	Character interpretation of the key that was pressed.	'a'	'='	' '	'A'
Modifier	Current modifier, such as 'control', or an empty cell array if there is no modifier	{1x0 cell}	{1x0 cell}	{'shift'}	{'shift'}
Key	Name of the key that was pressed.	'a'	'equal'	'shift'	'a'

The uitable `KeyPressFcn` callback executes for all keystrokes, including arrow keys or when a user edits cell content.

See “Function Handle Callbacks” for information on how to use function handles to define the callback function.

Parent  
handle

# Uitable Properties

---

*Uitable parent.* The handle of the uitable's parent object. You can move a uitable object to another figure, uipanel, or uibuttongroup by setting this property to the handle of the new parent.

## Position

position rectangle

*Size and location of uitable.* The rectangle defined by this property specifies the size and location of the table within the parent figure window, ui, or uibuttongroup. Specify **Position** as a 4-element vector:

[left bottom width height]

**left** and **bottom** are the distance from the lower-left corner of the parent object to the lower-left corner of the uitable object. **width** and **height** are the dimensions of the uitable rectangle. All measurements are in units specified by the **Units** property.

---

**Note** If you are specifying both **Units** and **Position** in the same call to `uitable`, specify **Units** first if you want **Position** to be interpreted using those units.

---

## RearrangeableColumns

on | {off}

*This object can be rearranged.* The **RearrangeableColumns** property provides a mechanism that you can use to reorder the columns in the table. All columns are rearrangeable when this property is turned on. MATLAB software sets the **RearrangeableColumns** property to `off` by default.

When this property is on, the user of a table can move any column of data (but not the row labels) at a time left or right to reorder it by clicking and dragging its header. Rearranging columns does

not affect the ordering of columns in the table's Data, only the user's view of it.

## RowName

*n*-by-1 cell array of strings | 1-by-*n* cell array of strings |  
{'numbered'} | empty matrix ([])

*Row heading names.* Each element of the cell array is the name of a row. Row names are restricted to one line of text.

For sequentially numbered row headings starting with 1, specify RowName as 'numbered'. This is the default.

To remove the row headings, specify RowName as the empty matrix ( []).

The number of rows in the table is the larger of RowName and the number of rows in the Data property matrix or cell array.

If you specify the RowName value as a 1-by-*n* cell array of strings, MATLAB stores and returns the value as a *n*-by-1 cell array of strings.

## RowStriping

{on} | off

*Color striping of table rows.* When RowStriping is on, the background of consecutive rows of the table display in the pair of colors that the BackgroundColor color matrix specifies. The first color matrix row applies to odd-numbered rows, and the second to even-numbered rows. If the BackgroundColor matrix has only one row, it is applied to all rows (that is, no striping occurs).

When RowStriping is off, the first color specified for BackgroundColor is applied to all rows.

## Selected

on | {off}

# Uitable Properties

---

*Is object selected.* When this property is on, MATLAB displays selection handles if the `SelectionHighlight` property is also on. You can, for example, define the `ButtonDownFcn` to set this property, allowing users to select the object with the mouse.

---

**Note** Use of the uitable `Selected` property is not recommended. This property may be removed in a future release.

---

`SelectionHighlight`  
{on} | off

*Object highlight when selected.* When the `Selected` property is on, MATLAB indicates the selected state by drawing four edge handles and four corner handles. When `SelectionHighlight` is off, MATLAB does not draw the handles.

---

**Note** Use of the uitable `SelectionHighlight` property is not recommended. This property may be removed in a future release.

---

`Tag`  
string (GUIDE sets this property)

*User-specified object label.* The `Tag` property provides a means to identify graphics objects with a user-specified label. This is particularly useful when constructing interactive graphics programs that would otherwise need to define object handles as global variables or pass them as arguments between callback routines. You can define `Tag` as any string.

`TooltipString`  
string



*Content of tooltip for object.* The `TooltipString` property specifies the text of the tooltip associated with the uitable. When the user moves the mouse pointer over the table and leaves it there, the tooltip is displayed.

To create a tooltip that has more than one line of text, use `sprintf` to generate a string containing newline (`\n`) characters and then set the `TooltipString` to that value. For example:

```
h = uitable;
s = sprintf('UITable tooltip line 1\nUITable tooltip line 2');
set(h,'TooltipString',s)
```

## Type

string (read only)

*Class of graphics object.* For uitable objects, `Type` is always the string `'uitable'`.

## UIContextMenu

handle

*Associate a context menu with uitable.* Assign this property the handle of a `uicontextmenu` object. MATLAB displays the context menu whenever you right-click over the uitable. Use the `uicontextmenu` function to create the context menu.

## Units

{pixels} | normalized | inches | centimeters | points | characters (GUIDE default: normalized)

*Units of measurement.* MATLAB uses these units to interpret the `Extent` and `Position` properties. All units are measured from the lower-left corner of the parent object.

- Normalized units map the lower-left corner of the parent object to (0,0) and the upper-right corner to (1.0,1.0).

# Uitable Properties

---

- pixels, inches, centimeters, and points are absolute units (1 point = 1/72 inch).
- Character units are characters using the default system font; the width of one character is the width of the letter x, the height of one character is the distance between the baselines of two lines of text.

If you change the value of `Units`, it is good practice to return it to its default value after completing your computation so as not to affect other functions that assume `Units` is set to the default value.

`UserData`  
matrix

*User-specified data.* Any data you want to associate with the uitable object. MATLAB does not use this data, but you can access it using `set` and `get`.

`Visible`  
{on} | off

*Uitable visibility.* By default, all uitables are visible. When set to `off`, the uitable is not visible, but still exists and you can query and set its properties.

---

**Note** Setting `Visible` to `off` for uitables that are not displayed initially in the GUI, can result in faster startup time for the GUI.

---

**Purpose** Create toggle button on toolbar

**Syntax**

```
htt = uitoggletool
htt =
uitoggletool('PropertyName1',value1,'PropertyName2',value2,
...)
htt = uitoggletool(ht,...)
```

**Description** `htt = uitoggletool` creates a toggle button on the uitoolbar at the top of the current figure window, sets all its properties to default values, and returns a handle to the tool. If no uitoolbar exists, one is created. The uitoolbar is the parent of the uitoggletool. Use the returned handle `htt` to set properties of the uitoggletool. The `OnCallback`, `OffCallback` and `ClickedCallback` use the handle as their first argument. The button has no icon, but its border highlights when you hover over it with the mouse cursor. Add an icon by setting `CData` for the tool. Type `get(htt)` to see a list of uitoggletool object properties and their current values. Type `set(htt)` to see a list of uitoggletool object properties you can set and legal property values.

```
htt =
uitoggletool('PropertyName1',value1,'PropertyName2',value2,
...)
```

assigns the specified property values, and assigns default values to the remaining properties. You can change the property values at a later time using the `set` function. You can specify properties as parameter name/value pairs, cell arrays containing parameter names and values, or structures with fields containing parameter names and values as input arguments. For a complete list, see `Uitoggletool Properties`. Type `get(htt)` to see a list of uipushtool object properties and their current values. Type `set(htt)` to see a list of uipushtool object properties that you can set and their legal property values.

`htt = uitoggletool(ht,...)` creates a button with `ht` as a parent. `ht` must be a uitoolbar handle.

Toggle tools appear in figures whose `Window Style` is `normal` or `docked`. They do not appear in figures with a `'modal'` `WindowStyle`. If the `WindowStyle` property of a figure containing a tool bar and its

# uitoggletool

---

toggle tool children changes to `modal`, the toggle tools continue to exist as Children of the tool bar. The toggle tools do not display until you change the `WindowState` to `normal` or `docked`.

## Examples

Create a `uitoolbar` object and places a `uitoggletool` object on it by specifying the toolbar handle as the toggle tool parent. Generate a random set of colors for the tool icon and specify a tool tip.

```
h = figure('ToolBar','none');
ht = uitoolbar(h);
a = rand(16,16,3);
htt = uitoggletool(ht,'CData',a,'TooltipString','Hello');
```

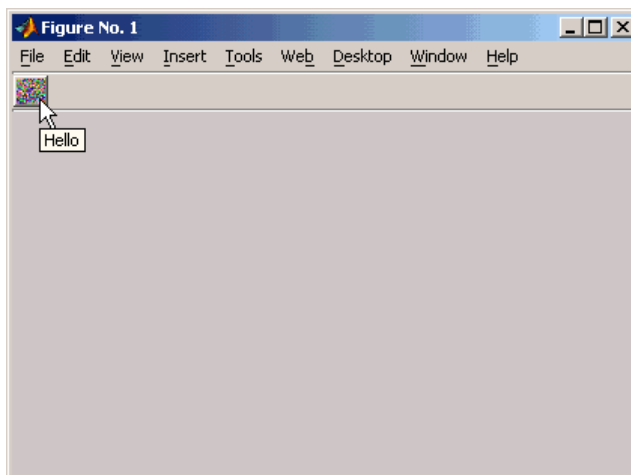

## Alternatives

You can create toolbars with toggle tools using `GUIDE`.

## See Also

`get` | `set` | `uicontrol` | `uipushtool` | `uitoolbar`

## Tutorials

- “GUI That Accepts and Returns Arguments”

## How To

- “Create Toolbars for Programmatic GUIs”

- “Create Toolbars for Programmatic GUIs”

# Uitoggletool Properties

---

## Purpose

Describe toggle tool properties

## Modifying Properties

You can set and query graphics object properties in two ways:

- The Property Inspector is an interactive tool that enables you to see and change object property values. The Property inspector is available from GUIDE, or use the `inspect` function at the command line.
- The `set` and `get` functions enable you to set and query the values of properties.

You can set default Uitoggletool properties by typing:

```
set(h, 'DefaultUitoggletoolPropertyName', PropertyValue...)
```

Where `h` can be the root handle (0), a figure handle, a uitoolbar handle, or a uitoggletool handle. *PropertyName* is the name of the Uitoggletool property and *PropertyValue* is the value you specify as the default for that property.

For more information about changing the default value of a property see “Setting Default Property Values”.

## Properties

This section lists all properties useful to uitoggletool objects along with valid values and a descriptions of their use. Curly braces { } enclose default values.

Property	Purpose
BeingDeleted	This object is being deleted.
BusyAction	Callback routine interruption.
CData	Truecolor image displayed on the toggle tool.
ClickedCallback	Control action independent of the toggle tool position.

# Uitoggletool Properties

Property	Purpose
CreateFcn	Callback routine executed during object creation.
DeleteFcn	Callback routine executed during object deletion.
Enable	Enable or disable the uitoggletool.
HandleVisibility	Control access to object's handle.
Interruptible	Callback routine interruption mode.
OffCallback	Control action when toggle tool is set to the off position.
OnCallback	Control action when toggle tool is set to the on position.
Parent	Handle of uitoggletool's parent toolbar.
Separator	Separator line mode.
State	Uitoggletool state.
Tag	User-specified object label.
TooltipString	Content of object's tooltip.
Type	Object class.
UIContextMenu	Uicontextmenu object associated with the uitoggletool
UserData	User specified data.
Visible	Uitoggletool visibility.

## BeingDeleted

on | {off} (read only)

*This object is being deleted.* The `BeingDeleted` property provides a mechanism that you can use to determine if objects are in the process of being deleted. MATLAB software sets the

# Uitoggletool Properties

---

BeingDeleted property to on when the object's delete function callback is called (see the DeleteFcn property) It remains set to on while the delete function executes, after which the object no longer exists.

For example, some functions may not need to perform actions on objects that are being deleted, and therefore, can check the object's BeingDeleted property before acting.

## BusyAction

cancel | {queue}

### *Callback queuing*

Determines how MATLAB handles the execution of interrupting callbacks.

A *running* callback is the currently executing callback. The *interrupting* callback is the callback that tries to interrupt the *running* callback. The BusyAction property of the *interrupting* callback determines how MATLAB handles its execution. When the BusyAction property is set to:

- 'queue' — Puts the *interrupting* callback in a queue to be processed after the *running* callback finishes execution.
- 'cancel' — Discards the *interrupting* callback as MATLAB finishes execution.

For information about how the Interruptible property of the callback controls whether other callbacks can interrupt the *running* callback, see the Interruptible property description.

## CData

3-dimensional array

*Truecolor image displayed on control as its icon.* An  $n$ -by- $m$ -by-3 array of RGB values that defines a truecolor image displayed on either a push button or toggle button. Each value must be



between 0.0 and 1.0. If your CData array is larger than 16 in the first or second dimension, it can be clipped or result in other undesirable effects. If the array is clipped, only the center 16-by-16 part of the array is used.

## ClickedCallback

string or function handle

*Control action independent of the toggle tool position.* A routine that executes after either the OnCallback routine or OffCallback routine runs to completion. The uitoggletool Enable property must be set to on.

## CreateFcn

string or function handle

*Callback routine executed during object creation.* The specified function executes when MATLAB creates a uitoggletool object. MATLAB sets all property values for the uitoggletool before executing the CreateFcn callback so these values are available to the callback. Within the function, use gcbo to get the handle of the toggle tool being created.

Setting this property on an existing uitoggletool object has no effect.

You can define a default CreateFcn callback for all new uitoggletools. This default applies unless you override it by specifying a different CreateFcn callback when you call uitoggletool. For example, the statement,

```
set(0, 'DefaultUitoggletoolCreateFcn', ...
 'set(gcbo, 'Enable', 'off')')
```

creates a default CreateFcn callback that runs whenever you create a new toggle tool. It sets the toggle tool Enable property to off.

# Uitoggletool Properties

---

To override this default and create a toggle tool whose `Enable` property is set to `on`, you could call `uitoggletool` with code similar to

```
htt = uitoggletool(...,'CreateFcn',...
 'set(gcbo,'Enable','on')',...)
```

---

**Note** To override a default `CreateFcn` callback you must provide a new callback and not just provide different values for the specified properties. This is because the `CreateFcn` callback runs after the property values are set, and can override property values you have set explicitly in the `uitoggletool` call. In the example above, if instead of redefining the `CreateFcn` property for this toggle tool, you had explicitly set `Enable` to `on`, the default `CreateFcn` callback would have set `CData` back to `off`.

---

Do not call `copyobj` or `textwrap` (which calls `copyobj`) inside a `CreateFcn`. The act of copying the `uicontrol` object fires the `CreateFcn` repeatedly, which raises a series of error messages after exceeding the root object's `RecursionLimit` property.

See [Function Handle Callbacks](#) for information on how to use function handles to define a callback function.

`DeleteFcn`  
string or function handle

*Callback routine executed during object deletion.* A callback routine that executes when you delete the `uitoggletool` object (e.g., when you call the `delete` function or cause the figure containing the `uitoggletool` to reset). MATLAB executes the routine before destroying the object's properties so these values are available to the callback routine.

The handle of the object whose `DeleteFcn` is being executed is accessible only through the root `CallbackObject` property, which you can query using `gcbo`.

See [Function Handle Callbacks](#) for information on how to use function handles to define a callback function.

## Enable

{on} | off

*Enable or disable the uitoggletool.* This property controls how uitoggletools respond to mouse button clicks, including which callback routines execute.

- **on** – The uitoggletool is operational (the default).
- **off** – The uitoggletool is not operational and its icon (set by the `Cdata` property) is grayed out.

When you left-click on a uitoggletool whose `Enable` property is `on`, MATLAB performs these actions in this order:

- 1** Executes the toggle tool `OnCallback` or `OffCallback` routine, depending on its current state, and its `ClickedCallback` routine.
- 2** Does *not* set the figure `CurrentPoint` property and does *not* execute the figure's `WindowButtonDownFcn` callback.
- 3** Does *not* set the figure `SelectionType` property.

When you left-click a uitoggletool whose `Enable` property is `off`, or when you right-click a uitoggletool whose `Enable` property has any value, no action is reported, no callback executes, and neither the `SelectionType` nor `CurrentPoint` figure properties are modified.

## HandleVisibility

{on} | callback | off

# Uitoggletool Properties

---

*Control access to object's handle.* This property determines when an object's handle is visible in its parent's list of children. When a handle is not visible in its parent's list of children, it is not returned by functions that obtain handles by searching the object hierarchy or querying handle properties. This includes `get`, `findobj`, `gca`, `gcf`, `gco`, `newplot`, `cla`, `clf`, and `close`. Neither is the handle visible in the parent figure's `CurrentObject` property. Handles that are hidden are still valid. If you know an object's handle, you can `set` and `get` its properties, and pass it to any function that operates on handles.

- Handles are always visible when `HandleVisibility` is `on`.
- Setting `HandleVisibility` to `callback` causes handles to be visible from within callback routines or functions invoked by callback routines, but not from within functions invoked from the command line. This provides a means to protect GUIs from command-line users, while allowing callback routines to have complete access to object handles.
- Setting `HandleVisibility` to `off` makes handles invisible at all times. This may be necessary when a callback routine invokes a function that might potentially damage the GUI (such as evaluating a user-typed string), and so temporarily hides its own handles during the execution of that function.

You can set the root `ShowHiddenHandles` property to `on` to make all handles visible, regardless of their `HandleVisibility` settings. This does not affect the values of the `HandleVisibility` properties.

`HitTest`  
{`on`} | `off`

*Selectable by mouse click.* This property has no effect on `uitoggletool` objects.

---

**Note** Use of the `uitoggletool HitTest` property is not recommended. This property might be removed in a future release.

---

## Interruptible

off | {on}

### *Callback routine interruption*

Controls whether MATLAB can interrupt an object's callback function when subsequent callbacks attempt to interrupt it.

For user interface objects, the `Interruptible` property affects the callbacks for these properties only:

- `ButtonDownFcn`
- `KeyPressFcn`
- `KeyReleaseFcn`
- `WindowButtonDownFcn`
- `WindowButtonMotionFcn`
- `WindowButtonUpFcn`
- `WindowKeyPressFcn`
- `WindowKeyReleaseFcn`
- `WindowScrollWheelFcn`

A *running* callback is the currently executing callback. The *interrupting* callback is the callback that tries to interrupt the *running* callback. MATLAB handles both callbacks based on the `Interruptible` property of the object of the *running* callback.

When the `Interruptible` property is set to:

# Uitoggletool Properties

---

- 'off', MATLAB finishes execution of the *running* callback without any interruptions
- 'on', these conditions apply:
  - If there is a `drawnow`, `figure`, `getframe`, `waitfor`, or `pause` command in the *running* callback, then MATLAB executes the *interrupting* callbacks which are already in the queue and returns to finish execution of the current callback.
  - If one of the above functions is not in the *running* callback, then MATLAB finishes execution of the current callback without any interruption.

The `BusyAction` property of the object of interrupting callback determines whether the callback should be ignored or should be put in the queue.

Setting the `Interruptible` property to `on` (default), allows a callback from other user interface objects to interrupt callback functions originating from this object.

---

**Note** MATLAB does not save the state of properties or the display when an interruption occurs. For example, the handle returned by the `gca` or `gcf` command may be changed as another callback is executed.

---

After the function that interrupts a callback completes, the callback resumes execution where it halted when interrupted. For more information, see “Control Callback Execution and Interruption”.

---

**Note** If the interrupting callback is a `DeleteFcn` or `CreateFcn` callback, or a figure's `CloseRequest` or `ResizeFcn` callback, it interrupts an executing callback regardless of the value of that object's `Interruptible` property. The interrupting callback starts execution at the next `drawnow`, `figure`, `getframe`, `pause`, or `waitfor` statement. An object's `ButtonDownFcn` or `Callback` routine is processed according to the rules described previously in this section.

---

## OffCallback

string or function handle

*Control action.* A routine that executes if the `uitoggletool`'s `Enable` property is set to `on`, and either

- The toggle tool `State` is set to `off`.
- The toggle tool is set to the `off` position by pressing a mouse button while the pointer is on the toggle tool itself or in a 5-pixel wide border around it.

The `ClickedCallback` routine, if there is one, runs after the `OffCallback` routine runs to completion.

## OnCallback

string or function handle

*Control action.* A routine that executes if the `uitoggletool`'s `Enable` property is set to `on`, and either

- The toggle tool `State` is set to `on`.
- The toggle tool is set to the `on` position by pressing a mouse button while the pointer is on the toggle tool itself or in a 5-pixel wide border around it.

# Uitoggletool Properties

---

The `ClickedCallback` routine, if there is one, runs after the `OffCallback` routine runs to completion.

## Parent

handle

*Uitoggletool parent.* The handle of the uitoggletool's parent toolbar. You can move a uitoggletool object to another toolbar by setting this property to the handle of the new parent.

## Separator

on | {off}

*Separator line mode.* Setting this property to on draws a dividing line to left of the uitoggletool.

## State

on | {off}

*Uitoggletool state.* When the state is on, the toggle tool appears in the down, or pressed, position. When the state is off, it appears in the up position. Changing the state causes the appropriate `OnCallback` or `OffCallback` routine to run.

## Tag

string

*User-specified object identifier.* The `Tag` property provides a means to identify graphics objects with a user-specified label. You can define `Tag` as any string.

With the `findobj` function, you can locate an object with a given `Tag` property value. This saves you from defining object handles as global variables. For example, this function call returns the handles of all children (of the specified toolbars) that have the `Tag` value 'Bold'.

```
h = findobj(uitoolbarhandles, 'Tag', 'Bold')
```



**TooltipString**  
string

*Content of tooltip for object.* The `TooltipString` property specifies the text of the tooltip associated with the `uitoggletool`. When the user moves the mouse pointer over the control and leaves it there, the tooltip is displayed.

To create a tooltip that has more than one line of text, use `sprintf` to generate a string containing newline (`\n`) characters and then set the `TooltipString` to that value. For example:

```
h = uitoggletool;
s = sprintf('Toggletool tooltip line 1\nToggletool tooltip line 2');
set(h,'TooltipString',s)
```

**Type**  
string (read-only)

Object class. This property identifies the kind of graphics object. For `uitoggletool` objects, `Type` is always the string `'uitoggletool'`.

**UIContextMenu**  
handle

*Associate a context menu with uicontrol.* This property has no effect on `uitoggletool` objects.

**UserData**  
array

*User specified data.* You can specify `UserData` as any array you want to associate with the `uitoggletool` object. The object does not use this data, but you can access it using the `set` and `get` functions.

**Visible**  
{on} | off

# Uitoggletool Properties

---

*Uitoggletool visibility.* By default, all uitoggletools are visible. When set to `off`, the uitoggletool is not visible, but still exists and you can query and set its properties.

<b>Purpose</b>	Create toolbar on figure
<b>Syntax</b>	<pre>ht = uitoolbar('PropertyName1',value1,'PropertyName2',value2,...) ht = uitoolbar(h,...)</pre>
<b>Description</b>	<p>ht = uitoolbar('PropertyName1',value1,'PropertyName2',value2,...) creates an empty toolbar at the top of the current figure window, and returns a handle to it. <code>uitoolbar</code> assigns the specified property values, and assigns default values to the remaining properties. You can change the property values at a later time using the <code>set</code> function.</p> <p>Type <code>get(ht)</code> to see a list of <code>uitoolbar</code> object properties and their current values. Type <code>set(ht)</code> to see a list of <code>uitoolbar</code> object properties that you can set and legal property values. See the <a href="#">Uitoolbar Properties</a> reference page for more information.</p> <p><code>ht = uitoolbar(h,...)</code> creates a toolbar with <code>h</code> as a parent. <code>h</code> must be a figure handle.</p>
<b>Tips</b>	<p><code>uitoolbar</code> accepts property name/property value pairs, as well as structures and cell arrays of properties as input arguments.</p> <p>Uitoolbars appear in figures whose <code>Window Style</code> is <code>normal</code> or <code>docked</code>. They do not appear in figures whose <code>WindowStyle</code> is <code>modal</code>. If the <code>WindowStyle</code> property of a figure containing a <code>uitoolbar</code> is changed to <code>modal</code>, the <code>uitoolbar</code> still exists and is contained in the <code>Children</code> list of the figure, but is not displayed until the <code>WindowStyle</code> is changed to <code>normal</code> or <code>docked</code>.</p>
<b>Examples</b>	<p>This example creates a figure with no toolbar, then adds a toolbar to it.</p> <pre>h = figure('ToolBar','none') ht = uitoolbar(h)</pre>

# uitoolbar

---

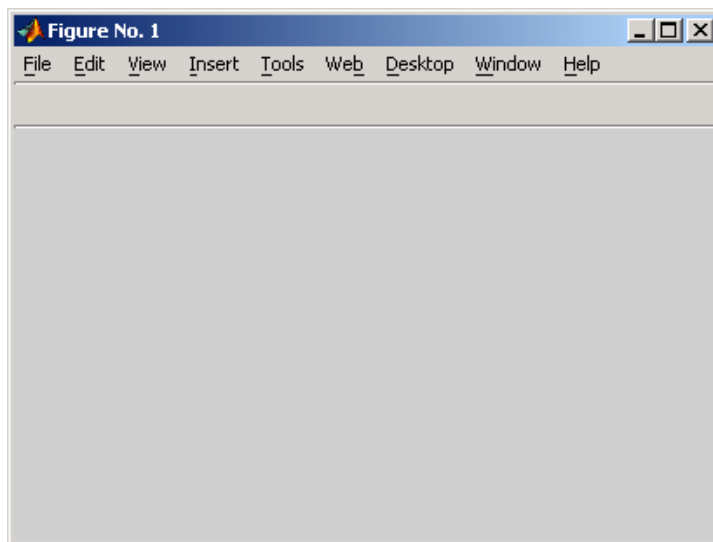

## See Also

`set` | `get` | `uicontrol` | `uipushtool` | `uitoggletool`

## Purpose

Describe toolbar properties

## Modifying Properties

You can set and query graphics object properties in two ways:

- The Property Inspector is an interactive tool that enables you to see and change object property values. The Property inspector is available from GUIDE, or use the `inspect` function at the command line.
- The `set` and `get` functions enable you to set and query the values of properties.

You can set default Uitoolbar properties by typing:

```
set(h, 'DefaultUitoolbarPropertyName', PropertyValue...)
```

Where `h` can be the root handle (0), a figure handle, or a uitoolbar handle. *PropertyName* is the name of the Uitoolbar property and *PropertyValue* is the value you specify as the default for that property.

For more information about changing the default value of a property see [Setting Default Property Values](#).

## Uitoolbar Properties

This section lists all properties useful to uitoolbar objects along with valid values and a descriptions of their use. Curly braces { } enclose default values.

Property	Purpose
BeingDeleted	This object is being deleted.
BusyAction	Callback routine interruption.
Children	Handles of uitoolbar's children.
CreateFcn	Callback routine executed during object creation.
DeleteFcn	Callback routine executed during object deletion.
HandleVisibility	Control access to object's handle.

# Uitoolbar Properties

---

Property	Purpose
Interruptible	Callback routine interruption mode.
Parent	Handle of uitoolbar's parent.
Tag	User-specified object identifier.
Type	Object class.
UIContextMenu	Uicontextmenu object associated with the uitoolbar
UserData	User specified data.
Visible	Uitoolbar visibility.

## BeingDeleted

on | {off} (read-only)

*This object is being deleted.* The **BeingDeleted** property provides a mechanism that you can use to determine if objects are in the process of being deleted. MATLAB software sets the **BeingDeleted** property to on when the object's delete function callback is called (see the **DeleteFcn** property) It remains set to on while the delete function executes, after which the object no longer exists.

For example, some functions may not need to perform actions on objects that are being deleted, and therefore, can check the object's **BeingDeleted** property before acting.

## BusyAction

cancel | {queue}

*Callback queuing*

Determines how MATLAB handles the execution of interrupting callbacks.

A *running* callback is the currently executing callback. The *interrupting* callback is the callback that tries to interrupt the *running* callback. The `BusyAction` property of the *interrupting* callback determines how MATLAB handles its execution. When the `BusyAction` property is set to:

- 'queue' — Puts the *interrupting* callback in a queue to be processed after the *running* callback finishes execution.
- 'cancel' — Discards the *interrupting* callback as MATLAB finishes execution.

For information about how the `Interruptible` property of the callback controls whether other callbacks can interrupt the *running* callback, see the `Interruptible` property description.

## Children

vector of handles

*Handles of tools on the toolbar.* A vector containing the handles of all children of the `uitoolbar` object, in the order in which they appear on the toolbar. The children objects of `uitoolbars` are `uipushtools` and `uitoggletools`. You can use this property to reorder the children.

## CreateFcn

string or function handle

*Callback routine executed during object creation.* The specified function executes when MATLAB creates a `uitoolbar` object. MATLAB sets all property values for the `uitoolbar` before executing the `CreateFcn` callback so these values are available to the callback. Within the function, use `gcbo` to get the handle of the toolbar being created.

Setting this property on an existing `uitoolbar` object has no effect.

# Uitoolbar Properties

---

You can define a default `CreateFcn` callback for all new uitoolbars. This default applies unless you override it by specifying a different `CreateFcn` callback when you call `uitoolbar`. For example, the statement,

```
set(0,'DefaultUitoolbarCreateFcn',...
 'set(gcbo,'Visibility','off')')
```

creates a default `CreateFcn` callback that runs whenever you create a new toolbar. It sets the toolbar visibility to `off`.

To override this default and create a toolbar whose `Visibility` property is set to `on`, you could call `uitoolbar` with a call similar to

```
ht = uitoolbar(...,'CreateFcn',...
 'set(gcbo,'Visibility','on')',...)
```

---

**Note** To override a default `CreateFcn` callback you must provide a new callback and not just provide different values for the specified properties. This is because the `CreateFcn` callback runs after the property values are set, and can override property values you have set explicitly in the `uitoolbar` call. In the example above, if instead of redefining the `CreateFcn` property for this toolbar, you had explicitly set `Visibility` to `on`, the default `CreateFcn` callback would have set `Visibility` back to `off`.

---

Do not call `copyobj` or `textwrap` (which calls `copyobj`) inside a `CreateFcn`. The act of copying the uicontrol object fires the `CreateFcn` repeatedly, which raises a series of error messages after exceeding the root object's `RecursionLimit` property.

See [Function Handle Callbacks](#) for information on how to use function handles to define a callback function.



## DeleteFcn

string or function handle

*Callback routine executed during object deletion.* A callback function that executes when the uitoolbar object is deleted (e.g., when you call the `delete` function or cause the figure containing the uitoolbar to reset). MATLAB executes the routine before destroying the object's properties so these values are available to the callback routine.

Within the function, use `gcbo` to get the handle of the toolbar being deleted.

## HandleVisibility

{on} | callback | off

*Control access to object's handle.* This property determines when an object's handle is visible in its parent's list of children. When a handle is not visible in its parent's list of children, it is not returned by functions that obtain handles by searching the object hierarchy or querying handle properties. This includes `get`, `findobj`, `gca`, `gcf`, `gco`, `newplot`, `cla`, `clf`, and `close`. Neither is the handle visible in the parent figure's `CurrentObject` property. Handles that are hidden are still valid. If you know an object's handle, you can `set` and `get` its properties, and pass it to any function that operates on handles.

- Handles are always visible when `HandleVisibility` is `on`.
- Setting `HandleVisibility` to `callback` causes handles to be visible from within callback routines or functions invoked by callback routines, but not from within functions invoked from the command line. This provides a means to protect GUIs from command-line users, while allowing callback routines to have complete access to object handles.
- Setting `HandleVisibility` to `off` makes handles invisible at all times. This may be necessary when a callback routine invokes a function that might potentially damage the GUI

# Uitoolbar Properties

---

(such as evaluating a user-typed string), and so temporarily hides its own handles during the execution of that function.

You can set the root `ShowHiddenHandles` property to `on` to make all handles visible, regardless of their `HandleVisibility` settings. This does not affect the values of the `HandleVisibility` properties.

`HitTest`  
`{on} | off`

*Selectable by mouse click.* This property has no effect on uitoolbar objects.

---

**Note** Use of the uitoolbar `HitTest` property is not recommended. This property might be removed in a future release.

---

`Interruptible`  
`off | {on}`

*Callback routine interruption*

Controls whether MATLAB can interrupt an object's callback function when subsequent callbacks attempt to interrupt it.

For user interface objects, the `Interruptible` property affects the callbacks for these properties only:

- `ButtonDownFcn`
- `KeyPressFcn`
- `KeyReleaseFcn`
- `WindowButtonDownFcn`

- WindowButtonMotionFcn
- WindowButtonUpFcn
- WindowKeyPressFcn
- WindowKeyReleaseFcn
- WindowScrollWheelFcn

A *running* callback is the currently executing callback. The *interrupting* callback is the callback that tries to interrupt the *running* callback. MATLAB handles both callbacks based on the `Interruptible` property of the object of the *running* callback.

When the `Interruptible` property is set to:

- 'off', MATLAB finishes execution of the *running* callback without any interruptions
- 'on', these conditions apply:
  - If there is a `drawnow`, `figure`, `getframe`, `waitfor`, or `pause` command in the *running* callback, then MATLAB executes the *interrupting* callbacks which are already in the queue and returns to finish execution of the current callback.
  - If one of the above functions is not in the *running* callback, then MATLAB finishes execution of the current callback without any interruption.

The `BusyAction` property of the object of interrupting callback determines whether the callback should be ignored or should be put in the queue.

Setting the `Interruptible` property to `on` (default), allows a callback from other user interface objects to interrupt callback functions originating from this object.

# Uitoolbar Properties

---

---

**Note** MATLAB does not save the state of properties or the display when an interruption occurs. For example, the handle returned by the `gca` or `gcf` command may be changed as another callback is executed.

---

After the function that interrupts a callback completes, the callback resumes execution where it halted when interrupted. For more information, see “Control Callback Execution and Interruption”.

---

**Note** If the interrupting callback is a `DeleteFcn` or `CreateFcn` callback, or a figure’s `CloseRequest` or `ResizeFcn` callback, it interrupts an executing callback regardless of the value of that object’s `Interruptible` property. The interrupting callback starts execution at the next `drawnow`, `figure`, `getframe`, `pause`, or `waitfor` statement. An object’s `ButtonDownFcn` or `Callback` routine is processed according to the rules described previously in this section.

---

Parent

handle

*Uitoolbar parent.* The handle of the uitoolbar’s parent figure. You can move a uitoolbar object to another figure by setting this property to the handle of the new parent.

Tag

string

*User-specified object identifier.* The `Tag` property provides a means to identify graphics objects with a user-specified label. You can define `Tag` as any string.

With the `findobj` function, you can locate an object with a given `Tag` property value. This saves you from defining object handles as global variables. For example, this function call returns the handles of all children (of the specified figures) that have the `Tag` value `'FormatTb'`.

```
h = findobj(figurehandles,'Tag','FormatTb')
```

## Type

string (read-only)

Object class. This property identifies the kind of graphics object. For uitoolbar objects, `Type` is always the string `'uitoolbar'`.

## UIContextMenu

handle

*Associate a context menu with uicontrol.* This property has no effect on uitoolbar objects.

## UserData

array

*User specified data.* You can specify `UserData` as any array you want to associate with the uitoolbar object. The object does not use this data, but you can access it using the `set` and `get` functions.

## Visible

{on} | off

*Uitoolbar visibility.* By default, all uitoolbars are visible. When set to `off`, the uitoolbar is not visible, but still exists and you can query and set its properties.

# uiwait

---

**Purpose** Block program execution and wait to resume

**Syntax**

```
uiwait
uiwait(h)
uiwait(h,timeout)
```

**Description** `uiwait` blocks execution until `uiresume` is called or the current figure is deleted. This syntax is the same as `uiwait(gcf)`.

`uiwait(h)` blocks execution until `uiresume` is called or the figure `h` is deleted.

`uiwait(h,timeout)` blocks execution until `uiresume` is called, the figure `h` is deleted, or `timeout` seconds elapse. The minimum value of `timeout` is 1. If `uiwait` receives a smaller value, it issues a warning and uses a 1 second `timeout`.

**Tips** The `uiwait` and `uiresume` functions block and resume MATLAB and Simulink program execution. `uiwait` also blocks the execution of Simulink models. The functions `pause` (with no argument) and `waitfor` also block execution in this manner. `uiwait` is a convenient way to use the `waitfor` command. You typically use it in conjunction with a dialog box. It provides a way to block the execution of the MATLAB program that created the dialog, until the user responds to the dialog box. When used in conjunction with a modal dialog, `uiwait` can block the execution of the program file *and* restrict user interaction to the dialog only.

**Examples** This example creates a GUI with a **Continue** push button. The example calls `uiwait` to block MATLAB execution until `uiresume` is called. This happens when the user clicks the **Continue** push button because the push button's `Callback`, which responds to the click, calls `uiresume`.

```
f = figure;
h = uicontrol('Position',[20 20 200 40],'String','Continue',...
 'Callback','uiresume(gcf)');
disp('This will print immediately');
uiwait(gcf);
```

```
disp('This will print after you click Continue');
close(f);
```

gcbf is the handle of the figure that contains the object whose callback is executing.

**See Also**

[dialog](#) | [figure](#) | [uicontrol](#) | [uimenu](#) | [uiresume](#) | [waitfor](#)

# uminus, -

---

**Purpose**           Unary minus

**Syntax**            C = -A  
                  C = uminus(A)

**Description**       C = -A negates the elements of A and stores the result in C.

C = uminus(A) is an alternative way to execute -A, but is rarely used. It enables operator overloading for classes.

**Input Arguments**

**A - Input array**

scalar | vector | matrix | multidimensional array

Input array, specified as a scalar, vector, matrix, or multidimensional array.

**Data Types**

single | double | int8 | int16 | int32 | int64 | uint8 | uint16 | uint32 | uint64 | logical | char

**Complex Number Support:** Yes

**Examples**

**Negate Elements of Matrix**

Create a 2-by-2 matrix, A.

```
A = [1 -3; -2 4]
```

```
A =
```

```
 1 -3
 -2 4
```

Negate the elements of A.

```
C = -A
```

```
C =
```



-1 3  
2 -4

**See Also**    minus | uplus

# undocheckout

---

**Purpose** Undo previous checkout from source control system (UNIX platforms)

**Syntax** `undocheckout('filename')`  
`undocheckout({'filename1', 'filename2', ..., 'filenamen'})`

**Description** `undocheckout('filename')` makes the file `filename` available for checkout, where `filename` does not reflect any of the changes you made after you last checked it out. Use the full path for `filename` and include the file extension.

`undocheckout({'filename1', 'filename2', ..., 'filenamen'})` makes `filename1` through `filenamen` available for checkout, where the files do not reflect any of the changes you made after you last checked them out. Use the full paths for the file names and include the file extensions.

**Examples** Undo the checkouts of `/myserver/myfiles/clock.m` and `/myserver/myfiles/calendar.m` from the source control system:

```
undocheckout({'/myserver/myfiles/clock.m', ...
 '/myserver/myfiles/calendar.m'})
```

**See Also** `checkin` | `checkout` | `verctrl`

**How To** • “Undo the Checkout (UNIX Platforms)”

<b>Purpose</b>	Convert Unicode character representation to numeric bytes
<b>Syntax</b>	<pre>bytes = unicode2native(unicodestr) bytes = unicode2native(unicodestr,encoding)</pre>
<b>Description</b>	<p><code>bytes = unicode2native(unicodestr)</code> converts a char vector of Unicode character representations, <code>unicodestr</code>, to the user default encoding, and returns the bytes as a <code>uint8</code> vector, <code>bytes</code>. Output vector <code>bytes</code> has the same general array shape as the <code>unicodestr</code> input. You can save the output of <code>unicode2native</code> to a file using the <code>fwrite</code> function.</p> <p><code>bytes = unicode2native(unicodestr,encoding)</code> converts <code>unicodestr</code> to the character encoding scheme specified by the string <code>encoding</code>. <code>encoding</code> must be the empty string ('') or a name or alias for an encoding scheme. Some examples are 'UTF-8', 'latin1', 'US-ASCII', and 'Shift_JIS'. If <code>encoding</code> is unspecified or is the empty string (''), the default encoding scheme is used.</p>
<b>Examples</b>	<p>This example begins with two strings containing Unicode character representations. It assumes that string <code>str1</code> contains text in a Western European language and string <code>str2</code> contains Japanese text. The example writes both strings into the same file, using the ISO-8859-1 character encoding scheme for the first string and the Shift-JIS encoding scheme for the second string. The example uses <code>unicode2native</code> to convert the two strings to the appropriate encoding schemes.</p> <pre>fid = fopen('mixed.txt', 'w'); bytes1 = unicode2native(str1, 'ISO-8859-1'); fwrite(fid, bytes1, 'uint8'); bytes2 = unicode2native(str2, 'Shift_JIS'); fwrite(fid, bytes2, 'uint8'); fclose(fid);</pre>
<b>See Also</b>	<code>native2unicode</code>

# union

---

**Purpose** Set union of two arrays

**Syntax**

```
C = union(A,B)
C = union(A,B, 'rows')
[C,ia,ib] = union(A,B)
[C,ia,ib] = union(A,B, 'rows')

[C,ia,ib] = union(__ ,setOrder)

[C,ia,ib] = union(A,B, 'legacy')

[C,ia,ib] = union(A,B, 'rows', 'legacy')
```

**Description** `C = union(A,B)` returns the combined data from A and B with no repetitions.

- If A and B are numeric arrays, logical arrays, character arrays, categorical arrays, or cell arrays of strings, then `union` returns the combined values from A and B. The values of C are in sorted order.
- If A and B are tables, then `union` returns the combined set of rows from both tables. The rows of table C are in sorted order.

`C = union(A,B, 'rows')` treats each row of A and each row of B as single entities and returns the combined rows from A and B with no repetitions. The rows of C are in sorted order.

The 'rows' option does not support cell arrays.

`[C,ia,ib] = union(A,B)` also returns index vectors `ia` and `ib`.

- If A and B are numeric arrays, logical arrays, character arrays, categorical arrays, or cell arrays of strings, then the values in C are a sorted combination of the values of A(`ia`) and B(`ib`).
- If A and B are tables, then C is a sorted combination of the rows of A(`ia,:`) and B(`ib,:`).

`[C,ia,ib] = union(A,B,'rows')` also returns index vectors `ia` and `ib`, such that the rows of `C` are a sorted combination of the rows of `A(ia,:)` and `B(ib,:)`.

`[C,ia,ib] = union(___,setOrder)` returns `C` in a specific order using any of the input arguments in the previous syntaxes. `setOrder='sorted'` returns the values (or rows) of `C` in sorted order. `setOrder='stable'` returns the values (or rows) of `C` in the same order as `A`, and then `B`. If no value is specified, the default is `'sorted'`.

`[C,ia,ib] = union(A,B,'legacy')` and `[C,ia,ib] = union(A,B,'rows','legacy')` preserve the behavior of the `union` function from R2012b and prior releases.

The `'legacy'` option does not support categorical arrays or tables.

## Input Arguments

### A,B - Input arrays

numeric arrays | logical arrays | character arrays | categorical arrays  
| cell arrays of strings | tables

Input arrays, specified as numeric arrays, logical arrays, character arrays, categorical arrays, cell arrays of strings, or tables.

`A` and `B` must be of the same class with the following exceptions:

- `logical`, `char`, and all numeric classes can combine with `double` arrays.
- Cell arrays of strings can combine with `char` arrays.
- Categorical arrays can combine with cell arrays of strings or single strings.

If `A` and `B` are both ordinal categorical arrays, they must have the same sets of categories, including their order. If neither `A` nor `B` are ordinal, they need not have the same sets of categories, and the comparison is performed using the category names. In this case, the categories of `C` are the sorted union of the categories from `A` and `B`.

# union

If you specify the 'rows' option, A and B must have the same number of columns.

If A and B are tables, they must have the same variable names. Conversely, the row names do not matter. Two rows that have the same values, but different names, are considered equal.

Furthermore, A and B can be objects with the following class methods:

- sort (or sortrows for the 'rows' option)
- ne

The object class methods must be consistent with each other. These objects include heterogeneous arrays derived from the same root class.

## setOrder - Order flag

'sorted' (default) | 'stable'

Order flag, specified as 'sorted' or 'stable', indicates the order of the values (or rows) in C.

Order Flag	Meaning
'sorted'	The values (or rows) in C return in sorted order. For example: C = union([5 5 3],[1 2], 'sorted') returns C = [1 2 3 5].
'stable'	The values (or rows) in C return in the same order as they appear in A and B. For example: C = union([5 5 3],[1 2], 'stable') returns C = [5 3 1 2].

## Output Arguments

### C - Combined data of A and B

vector | matrix | table

Combined data of A and B, returned as a vector, matrix, or table. If the inputs A and B are tables, the order of the variables in the resulting table, C, is the same as the order of the variables in A.

The following describes the shape of **C** when the inputs are vector or matrices and when the 'legacy' flag is not specified:

- If the 'rows' flag is not specified, then **C** is a column vector unless both **A** and **B** are row vectors.
- If the 'rows' flag is not specified and both **A** and **B** are row vectors, then **C** is a row vector.
- If the 'rows' flag is specified, then **C** is a matrix containing the combined rows of **A** and **B**.

The class of the inputs **A** and **B** determines the class of **C**:

- If the class of **A** and **B** are the same, then **C** is the same class.
- If you combine a `char` or nondouble numeric class with `double`, then **C** is the same class as the nondouble input.
- If you combine a `logical` class with `double`, then **C** is `double`.
- If you combine a cell array of strings with `char`, then **C** is a cell array of strings.
- If you combine a categorical array with a cell array of strings or single string, then **C** is a categorical array.

### **ia - Index to A**

column vector

Index to **A**, returned as a column vector when the 'legacy' flag is not specified. **ia** indicates the values (or rows) in **A** that contribute to the union. If a value (or row) appears multiple times in **A**, then **ia** contains the index to the first occurrence of the value (or row). If a value appears in both **A** and **B**, then **ia** contains the index to the first occurrence in **A**.

### **ib - Index to B**

column vector

Index to **B**, returned as a column vector when the 'legacy' flag is not specified. **ib** indicates the values (or rows) in **B** that contribute to the union. If there is a repeated value (or row) appearing exclusively in **B**,

then `ib` contains the index to the first occurrence of the value. If a value (or row) appears in both A and B, then `ib` does not contain an index to the value (or row).

## Examples

### Union of Two Vectors

Define two vectors with a value in common.

```
A = [5 7 1]; B = [3 1 1];
```

Find the union of vectors A and B.

```
C = union(A,B)
```

```
C =
```

```
 1 3 5 7
```

### Union of Two Tables

Define two tables with rows in common.

```
A = table([1:5]', ['A'; 'B'; 'C'; 'D'; 'E'], logical([0;1;0;1;0]))
```

```
B = table([1:2:10]', ['A'; 'C'; 'E'; 'G'; 'I'], logical(zeros(5,1)))
```

```
A =
```

Var1	Var2	Var3
1	A	false
2	B	true
3	C	false
4	D	true
5	E	false

```
B =
```

Var1	Var2	Var3
------	------	------



```

1 A false
3 C false
5 E false
7 G false
9 I false

```

Find the union of tables A and B.

```
C = union(A,B)
```

```
C =
```

```

Var1 Var2 Var3

1 A false
2 B true
3 C false
4 D true
5 E false
7 G false
9 I false

```

### Union of Two Vectors and Their Indices

Define two vectors with a value in common.

```
A = [5 7 1]; B = [3 1 1];
```

Find the union of vectors A and B, as well as the index vectors, ia and ib.

```
[C,ia,ib] = union(A,B)
```

```
C =
```

```
1 3 5 7
```

# union

---

```
ia =
```

```
 3
 1
 2
```

```
ib =
```

```
 1
```

The values in C are the combined values of A(ia) and B(ib).

## Union of Two Tables and Their Indices

Define a table, A, of gender, age, and height for three people.

```
A = table(['M';'M';'F'],[27;52;31],[74;68;64],...
'VariableNames',{'Gender' 'Age' 'Height'},...
'RowNames',{'Ted' 'Fred' 'Betty'})
```

```
A =
```

	Gender	Age	Height
	-----	---	-----
Ted	M	27	74
Fred	M	52	68
Betty	F	31	64

Define a table, B with the same variables as A.

```
B = table(['F';'M'],[64;68],[31;47],...
'VariableNames',{'Gender' 'Height' 'Age'},...
'RowNames',{'Meg' 'Joe'})
```

```
B =
```

	Gender	Height	Age
--	--------	--------	-----

	-----	-----	---
Meg	F	64	31
Joe	M	68	47

Find the union of tables A and B, as well as the index vectors, `ia` and `ib`.

```
[C,ia,ib] = union(A,B)
```

C =

	Gender	Age	Height
	-----	---	-----
Betty	F	31	64
Ted	M	27	74
Joe	M	47	68
Fred	M	52	68

ia =

```
3
1
2
```

ib =

```
2
```

The data for Meg and Betty are the same. `union` only returns the index from A, which corresponds to Betty.

### Union of Rows in Two Matrices

Define two matrices with a row in common.

```
A = [2 2 2; 0 0 1];
B = [1 2 3; 2 2 2; 2 2 2];
```

# union

---

Find the combined rows of A and B, with no repetition, as well as the index vectors ia and ib.

```
[C,ia,ib] = union(A,B,'rows')
```

```
C =
```

```
 0 0 1
 1 2 3
 2 2 2
```

```
ia =
```

```
 2
 1
```

```
ib =
```

```
 1
```

The rows of C are the combined rows of A(ia,:) and B(ib,:).

## **Union of Two Vectors with Specified Output Order**

Use the `setOrder` argument to specify the ordering of the values in C.

Specify `'stable'` if you want the values in C to have the same order as in A and B.

```
A = [5 7 1]; B = [3 1 1];
[C,ia,ib] = union(A,B,'stable')
```

```
C =
```

```
 5 7 1 3
```

```
ia =
```

```
1
2
3
```

```
ib =
```

```
1
```

Alternatively, you can specify 'sorted' order.

```
A = [5 7 1]; B = [3 1 1];
[C,ia,ib] = union(A,B,'sorted')
```

```
C =
```

```
1 3 5 7
```

```
ia =
```

```
3
1
2
```

```
ib =
```

```
1
```

### **Union of Vectors Containing NaNs**

Define two vectors containing NaN.

```
A = [5 NaN 1]; B = [4 NaN NaN];
```

Find the union of vectors A and B.

# union

---

```
C = union(A,B)
C =
 1 4 5 NaN NaN NaN
```

union treats NaN values as distinct.

## Cell Array of Strings with Trailing White Space

Create a cell array of strings, A.

```
A = {'dog', 'cat', 'fish', 'horse'};
```

Create a cell array of strings, B, where some of the strings have trailing white space.

```
B = {'dog ', 'cat', 'fish ', 'horse'};
```

Combine the elements of A and B.

```
[C,ia,ib] = union(A,B)
C =
 'cat' 'dog' 'dog ' 'fish' 'fish ' 'horse'

ia =
 2
 1
 3
 4

ib =
 1
```

3

union treats trailing white space in cell arrays of strings as distinct characters.

### **Union of Vectors of Different Classes and Shapes**

Create a column vector character array.

```
A = ['A'; 'B'; 'C'], class(A)
```

```
A =
```

```
A
```

```
B
```

```
C
```

```
ans =
```

```
char
```

Create a row vector containing elements of numeric type double.

```
B = [68 69 70], class(B)
```

```
B =
```

```
68 69 70
```

```
ans =
```

```
double
```

The union of A and B returns a column vector character array.

# union

---

```
C = union(A,B), class(C)
```

```
C =
```

```
A
```

```
B
```

```
C
```

```
D
```

```
E
```

```
F
```

```
ans =
```

```
char
```

## **Union of Char and Cell Array of Strings**

Create a character array containing the letters a , b, and c.

```
A = ['a'; 'b'; 'c'];
class(A)
```

```
ans =
```

```
char
```

Create a cell array of strings containing the letters c, d, and e.

```
B = {'c', 'd', 'e'};
class(B)
```

```
ans =
```

```
cell
```



Combine the elements of A and B.

```
C = union(A,B)
```

```
C =
```

```
 'a'
 'b'
 'c'
 'd'
 'e'
```

The result, C, is a cell array of strings.

```
class(C)
```

```
ans =
```

```
cell
```

### Preserve Legacy Behavior of union

Use the 'legacy' flag to preserve the behavior of union from R2012b and prior releases in your code.

Find the union of A and B with the current behavior.

```
A = [5 7 1]; B = [3 1 1];
[C1,ia1,ib1] = union(A,B)
```

```
C1 =
```

```
 1 3 5 7
```

```
ia1 =
```

```
 3
```

# union

---

```
1
2
```

```
ib1 =

1
```

Find the union of A and B, and preserve the legacy behavior.

```
A = [5 7 1]; B = [3 1 1];
[C2,ia2,ib2] = union(A,B,'legacy')
```

```
C2 =

1 3 5 7
```

```
ia2 =

1 2
```

```
ib2 =

3 1
```

## Tips

- To find the union with respect to a subset of variables from a table, you can use column subscripting. For example, you can use `union(A(:,vars),B(:,vars))`, where `vars` is a positive integer, a vector of positive integers, a variable name, a cell array of variable names, or a logical vector.

## See Also

`unique` | `intersect` | `ismember` | `issorted` | `setdiff` | `setxor` | `sort`

## Concepts

- “Combine Categorical Arrays”

**Purpose**

Unique values in array

**Syntax**

```
C = unique(A)
C = unique(A,'rows')
[C,ia,ic] = unique(A)
[C,ia,ic] = unique(A,'rows')

[C,ia,ic] = unique(A,setOrder)

[C,ia,ic] = unique(A,'rows',setOrder)

[C,ia,ic] = unique(A,'legacy')

[C,ia,ic] = unique(A,'rows','legacy')

[C,ia,ic] = unique(A,occurrence,'legacy')

[C,ia,ic] = unique(A,'rows',occurrence,'legacy')
```

**Description**

`C = unique(A)` returns the same data as in `A`, but with no repetitions.

- If `A` is a numeric array, logical array, character array, categorical array, or a cell array of strings, then `unique` returns the unique values in `A`. The values of `C` are in sorted order.
- If `A` is a table, then `unique` returns the unique rows in `A`. The rows of table `C` are in sorted order.

`C = unique(A,'rows')` treats each row of `A` as a single entity and returns the unique rows of `A`. The rows of the array `C` are in sorted order.

The `'rows'` option does not support cell arrays.

`[C,ia,ic] = unique(A)` also returns index vectors `ia` and `ic`.

- If `A` is a numeric array, logical array, character array, categorical array, or a cell array of strings, then `C = A(ia)` and `A = C(ic)`.

# unique

---

- If `A` is a table, then `C = A(ia,:)` and `A = C(ic,:)`.

`[C,ia,ic] = unique(A,'rows')` also returns index vectors `ia` and `ic`, such that `C = A(ia,:)` and `A = C(ic,:)`.

`[C,ia,ic] = unique(A,setOrder)` and `[C,ia,ic] = unique(A,'rows',setOrder)` return `C` in a specific order. `setOrder='sorted'` returns the values (or rows) of `C` in sorted order. `setOrder='stable'` returns the values (or rows) of `C` in the same order as `A`. If no value is specified, the default is `'sorted'`.

`[C,ia,ic] = unique(A,'legacy')`, `[C,ia,ic] = unique(A,'rows','legacy')`, `[C,ia,ic] = unique(A,occurrence,'legacy')`, and `[C,ia,ic] = unique(A,'rows',occurrence,'legacy')` preserve the behavior of the `unique` function from R2012b and prior releases.

The `'legacy'` option does not support categorical arrays or tables.

## Input Arguments

### **A** - Input array

numeric array | logical array | character array | categorical array | cell array of strings | table

Input array, specified as a numeric array, logical array, character array, categorical array, cell array of strings, or table.

If `A` is a table, `unique` does not take row names into account. Two rows that have the same values, but different names, are considered equal.

Furthermore, `A` can be an object with the following class methods:

- `sort` (or `sortrows` for the `'rows'` option)
- `ne`

The object class methods must be consistent with each other. These objects include heterogeneous arrays derived from the same root class.

### **setOrder** - Order flag

'sorted' (default) | 'stable'

Order flag, specified as 'sorted' or 'stable', indicates the order of the values (or rows) in C.

Order Flag	Meaning
'sorted'	The values (or rows) in C return in sorted order. For example: C = unique([5 5 3 4], 'sorted') returns C = [3 4 5].
'stable'	The values (or rows) in C return in the same order as in A. For example: C = unique([5 5 3 4], 'stable') returns C = [5 3 4].

**occurrence - Occurrence flag for legacy behavior**

'last' (default) | 'first'

Occurrence flag for legacy behavior, specified as 'first' or 'last', indicates whether ia should contain the first or last indices to repeated values found in A.

Occurrence Flag	Meaning
'last'	If there are repeated values (or rows) in A, then ia contains the index to the last occurrence of the repeated value. For example: [C,ia,ic] = unique([9 9 9], 'last', 'legacy') returns ia = 3.
'first'	If there are repeated values (or rows) in A, then ia contains the index to the first occurrence of the repeated value. For example: [C,ia,ic] = unique([9 9 9], 'first', 'legacy') returns ia = 1.

# unique

---

## Output Arguments

### **C** - Unique data of A

vector | matrix | table

Unique data of A, returned as a vector, matrix, or table. The following describes the shape of C when the input, A, is a vector or a matrix:

- If the 'rows' flag is not specified and A is a row vector, then C is a row vector.
- If the 'rows' flag is not specified and A is not a row vector, then C is a column vector.
- If the 'rows' flag is specified, then C is a matrix containing the unique rows of A.

The class of C is the same as the class of the input A.

### **ia** - Index to A

column vector

Index to A, returned as a column vector of indices to the first occurrence of repeated elements. When the 'legacy' flag is specified, ia is a row vector that contains indices to the last occurrence of repeated elements.

The indices satisfy  $C = A(ia)$  (or  $C = A(ia, :)$  for the 'rows' option).

### **ic** - Index to C

column vector

Index to C, returned as a column vector when the 'legacy' flag is not specified. ic contains indices, such that  $A = C(ic)$  (or  $A = C(ic, :)$  for the 'rows' option).

## Examples

### Unique Values in Vector

Define a vector with a repeated value.

```
A = [9 2 9 5];
```

Find the unique values of A.

```
C = unique(A)
```

```
C =
```

```
 2 5 9
```

### Unique Rows in Table

Define a table with repeated data.

```
Name = {'Fred'; 'Betty'; 'Bob'; 'George'; 'Jane'};
```

```
Age = [38; 43; 38; 40; 38];
```

```
Height = [71; 69; 64; 67; 64];
```

```
Weight = [176; 163; 131; 185; 131];
```

```
A = table(Age, Height, Weight, 'RowNames', Name)
```

```
A =
```

	Age	Height	Weight
	---	-----	-----
Fred	38	71	176
Betty	43	69	163
Bob	38	64	131
George	40	67	185
Jane	38	64	131

Find the unique rows of A.

```
C = unique(A)
```

```
C =
```

	Age	Height	Weight
	---	-----	-----
Bob	38	64	131
Fred	38	71	176
George	40	67	185
Betty	43	69	163

# unique

---

`unique` returns the rows of `A` in sorted order by the first variable, `Age` and then by the second variable, `Height`.

## Unique Values and Their Indices

Define a vector with a repeated value.

```
A = [9 2 9 5];
```

Find the unique values of `A` and the index vectors `ia` and `ic`, such that `C = A(ia)` and `A = C(ic)`.

```
[C, ia, ic] = unique(A)
```

```
C =
```

```
 2 5 9
```

```
ia =
```

```
 2
 4
 1
```

```
ic =
```

```
 3
 1
 3
 2
```

## Unique Rows in Matrix

Define a matrix with a repeated row.

```
A = [9 2 9 5; 9 2 9 0; 9 2 9 5];
```



Find the unique rows of A and the index vectors `ia` and `ic`, such that `C = A(ia,:)` and `A = C(ic,:)`.

```
[C, ia, ic] = unique(A, 'rows')
```

```
C =
```

```
 9 2 9 0
 9 2 9 5
```

```
ia =
```

```
 2
 1
```

```
ic =
```

```
 2
 1
 2
```

Notice that the second row in A is identified as unique even though the elements 9, 2, and 9 are repeated in the other rows.

### Unique Values in Vector with Specified Order

Use the `setOrder` argument to specify the ordering of the values in C.

Specify `'stable'` if you want the values in C to have the same order as in A.

```
A = [9 2 9 5];
[C, ia, ic] = unique(A, 'stable')
```

```
C =
```

```
 9 2 5
```

# unique

---

```
ia =
```

```
1
2
4
```

```
ic =
```

```
1
2
1
3
```

Alternatively, you can specify 'sorted' order.

```
[C, ia, ic] = unique(A, 'sorted')
```

```
C =
```

```
2 5 9
```

```
ia =
```

```
2
4
1
```

```
ic =
```

```
3
1
3
```

2

### Unique Values in Array Containing NaNs

Define a vector containing NaN.

```
A = [5 5 NaN NaN];
```

Find the unique values of A.

```
C = unique(A)
```

```
C =
```

```
 5 NaN NaN
```

unique treats NaN values as distinct.

### Unique Entries in Cell Array of Strings

Define a cell array of strings.

```
A = {'one', 'two', 'twenty-two', 'One', 'two'};
```

Find the unique strings contained in A.

```
C = unique(A)
```

```
C =
```

```
 'One' 'one' 'twenty-two' 'two'
```

### Cell Array of Strings with Trailing White Space

Define a cell array of strings, A, where some of the strings have trailing white space.

```
A = {'dog', 'cat', 'fish', 'horse', 'dog ', 'fish '};
```

Find the unique strings contained in A.

# unique

---

```
C = unique(A)
```

```
C =
```

```
 'cat' 'dog' 'dog ' 'fish' 'fish ' 'horse'
```

`unique` treats trailing white space in cell arrays of strings as distinct characters.

## Preserve Legacy Behavior of `unique`

Use the `'legacy'` flag to preserve the behavior of `unique` from R2012b and prior releases in your code.

Find the unique elements of `A` with the current behavior.

```
A = [9 2 9 5];
```

```
[C1, ia1, ic1] = unique(A)
```

```
C1 =
```

```
 2 5 9
```

```
ia1 =
```

```
 2
 4
 1
```

```
ic1 =
```

```
 3
 1
 3
 2
```

Find the unique elements of `A`, and preserve the legacy behavior.

```
[C2, ia2, ic2] = unique(A, 'legacy')
```

```
C2 =
```

```
 2 5 9
```

```
ia2 =
```

```
 2 4 3
```

```
ic2 =
```

```
 3 1 3 2
```

## Tips

- To find unique rows in table A with respect to a subset of variables, you can use column subscripting. For example, you can use `unique(A(:,vars))`, where *vars* is a positive integer, a vector of positive integers, a variable name, a cell array of variable names, or a logical vector.

## See Also

`union` | `intersect` | `ismember` | `issorted` | `setdiff` | `setxor` | `sort`

# matlab.unittest

---

**Purpose** Summary of packages and classes in MATLAB Unit Test Framework

**Description** The matlab.unittest package consists of the following classes and packages:

matlab.unittest.constraints	Summary of classes in MATLAB Constraints Interface
matlab.unittest.diagnostics	Summary of classes in MATLAB Diagnostics Interface
matlab.unittest.fixtures	Summary of classes in MATLAB Fixtures Interface
matlab.unittest.parameters	Summary of classes associated with MATLAB Unit Test parameters
matlab.unittest.plugins	Summary of classes in MATLAB Plugins Interface
matlab.unittest.plugins.plugindata	Summary of classes in MATLAB Plugin Data Interface
matlab.unittest.qualifications	Summary of classes in MATLAB Qualifications Interface
matlab.unittest.selectors	Summary of classes in MATLAB Selectors Interface
matlab.unittest.Test	Specification of a single test method
matlab.unittest.TestCase	Superclass of all <code>matlab.unittest</code> test classes
matlab.unittest.TestResult	Result of running test suite
matlab.unittest.TestRunner	Class for running tests in <code>matlab.unittest</code> framework
matlab.unittest.TestSuite	Class for grouping tests to run

**Purpose**

Execute UNIX command and return output

**Syntax**

```
status = unix(command)
[status,cmdout] = unix(command)
[status,cmdout] = unix(command,'-echo')
```

**Description**

`status = unix(command)` calls the UNIX operating system to execute the specified command. The operation waits for the command to finish execution before returning the exit status of the command to the `status` variable.

`[status,cmdout] = unix(command)` additionally returns the standard output of the command to `cmdout`. This syntax is most useful for commands that do not require user input.

`[status,cmdout] = unix(command,'-echo')` additionally displays (echoes) the command output in the MATLAB Command Window. This syntax is most useful for commands that require user input and that run correctly in the MATLAB Command Window.

**Input Arguments**

**command - UNIX command**

string

UNIX command, specified as a string. The command executes in a UNIX shell, which might not be the shell from which you launched MATLAB.

**Example:** 'ls'

**Output Arguments**

**status - Command exit status**

0 | nonzero integer

Command exit status, returned as either 0 or a nonzero integer. When the command is successful, `status` is 0. Otherwise, `status` is a nonzero integer.

- If `command` includes the ampersand character (&), then `status` is the exit status upon command launch.

- If `command` does not include the ampersand character (&), then `status` is the exit status upon command completion.

## **cmdout - Output of operating system command**

string

Output of the operating system command, returned as a string.

## **Examples**

### **Save UNIX Command Exit Status and Output**

List all users who are currently logged in, and save the command exit status and output. Then, view the status.

```
command = 'who';
[status,cmdout] = unix(command);
status
```

```
status =
```

```
0
```

A `status` of zero indicates that the command completed successfully. MATLAB returns a string containing the list of users in `cmdout`.

## **Tips**

- To execute the operating system command in the background, include the trailing character, &, in the `command` argument (for example, `'emacs &'`). The exit status is immediately returned to the `status` variable. This syntax is useful for console programs that require interactive user command input while they run, and that do not run correctly in the MATLAB Command Window.

---

**Note** If `command` includes the trailing & character, `cmdout` is empty.

---

- The `unix` function redirects `stdin` to the invoked command, `command`, by default. This redirection also forwards MATLAB script commands and the keyboard type-ahead buffer to the invoked command while



the `unix` function executes. This can lead to corrupted output when `unix` does not complete execution immediately. To disable `stdin` and type-ahead redirection, include the formatted string `< /dev/null` in the call to the invoked command.

## Algorithms

MATLAB uses a shell program to execute the given command. It determines which shell program to use by checking environment variables on your system. MATLAB first checks the `MATLAB_SHELL` variable, and if either empty or not defined, then checks `SHELL`. If `SHELL` is also empty or not defined, MATLAB uses `/bin/sh`.

## See Also

! (exclamation point) | computer | dos | perl | system

## Concepts

- “Run External Commands, Scripts, and Programs”

# unloadlibrary

---

<b>Purpose</b>	Unload shared library from memory
<b>Syntax</b>	<code>unloadlibrary libname</code>
<b>Description</b>	<code>unloadlibrary libname</code> unloads library <code>libname</code> from memory.
<b>Limitations</b>	<ul style="list-style-type: none"><li>• Use with libraries that are loaded using the <code>loadlibrary</code> function.</li></ul>
<b>Input Arguments</b>	<p><b>libname</b> - Name of shared library</p> <p>string</p> <p>Name of shared library, specified as a string. If you call <code>loadlibrary</code> using the <code>alias</code> option, then you must use the alias name for the <code>libname</code> argument.</p> <p><b>Data Types</b></p> <p>char</p>
<b>Examples</b>	<p><b>Unload Library</b></p> <p>Add path to examples folder.</p> <pre>addpath(fullfile(matlabroot,'extern','examples','shrlib'))</pre> <p>Load the library, if it is not already loaded.</p> <pre>if ~libisloaded('shrlibsample')     loadlibrary('shrlibsample') end</pre> <p>Clean up.</p> <pre>unloadlibrary shrlibsample</pre>
<b>Tips</b>	<ul style="list-style-type: none"><li>• To unload a MEX-file, use the <code>clear</code> function.</li></ul>
<b>See Also</b>	<code>loadlibrary</code>   <code>libisloaded</code>   <code>clear</code>

---

<b>Purpose</b>	Convert edge matrix to coordinate and Laplacian matrices	
<b>Syntax</b>	$[L,XY] = \text{unmesh}(E)$	
<b>Description</b>	$[L,XY] = \text{unmesh}(E)$ returns the Laplacian matrix $L$ and mesh vertex coordinate matrix $XY$ for the $M$ -by-4 edge matrix $E$ . Each row of the edge matrix must contain the coordinates $[x1\ y1\ x2\ y2]$ of the edge endpoints.	
<b>Input Arguments</b>	$E$	$M$ -by-4 edge matrix $E$ .
<b>Output Arguments</b>	$L$	Laplacian matrix representation of the graph.
	$XY$	Mesh vertex coordinate matrix.
<b>Examples</b>	Take a simple example of a square with vertices at $(1,1)$ , $(1,-1)$ , $(-1,-1)$ , and $(-1,1)$ , where the connections between vertices are the four perpendicular edges of the square plus one diagonal connection between $(-1, -1)$ and $(1,1)$ .	

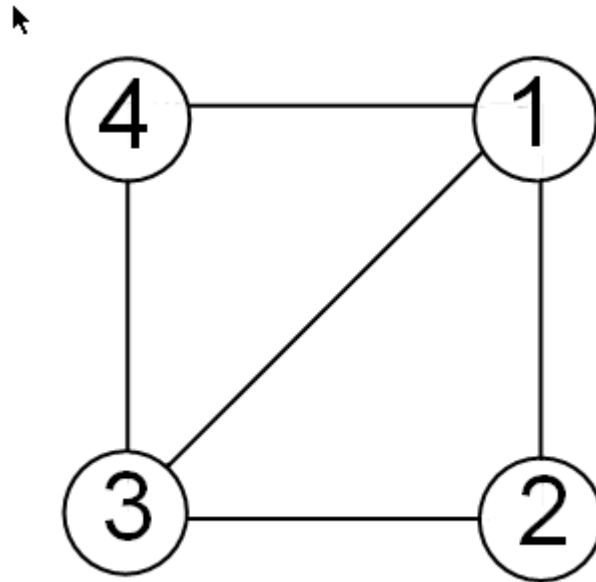

The edge matrix E for this graph is:

```
E=[1 1 1 -1; % edge from 1 to 2
1 -1 -1 -1; % edge from 2 to 3
-1 -1 -1 1; % edge from 3 to 4
-1 -1 1 1; % edge from 4 to 1
-1 1 1 1] % edge from 3 to 1
```

Use unmesh to create the output matrices,

```
[A,XY]=unmesh(E);
4 vertices:
4/4
```

The Laplacian matrix is defined as

$$L_{ij} = \begin{cases} \deg(v_i) & \text{if } i = j \\ -1 & \text{if } i \neq j \text{ and } v_i \text{ is adjacent to } v_j \\ 0 & \text{otherwise} \end{cases}$$

unmesh returns the Laplacian matrix L in sparse notation.

L

L =

(1,1)	3
(2,1)	-1
(3,1)	-1
(4,1)	-1
(1,2)	-1
(2,2)	2
(4,2)	-1
(1,3)	-1
(3,3)	2
(4,3)	-1
(1,4)	-1
(2,4)	-1
(3,4)	-1

To see L in regular matrix notation, use the full command.

full(L)

ans =

3	-1	-1	-1
-1	2	0	-1
-1	0	2	-1
-1	-1	-1	3

The mesh coordinate matrix XY returns the coordinates of the corners of the square.

# unmesh

---

XY

XY =

```
-1 -1
-1 1
 1 -1
 1 1
```

## See Also

[gplot](#) | [treepplot](#)

**Purpose** Piecewise polynomial details

**Syntax** `[breaks,coefs,l,k,d] = unmkpp(pp)`

**Description** `[breaks,coefs,l,k,d] = unmkpp(pp)` extracts, from the piecewise polynomial `pp`, its breaks `breaks`, coefficients `coefs`, number of pieces `l`, order `k`, and dimension `d` of its target. Create `pp` using `spline` or the spline utility `mkpp`.

**Examples** This example creates a description of the quadratic polynomial

$$\frac{-x^2}{4} + x$$

as a piecewise polynomial `pp`, then extracts the details of that description.

```
pp = mkpp([-8 -4],[-1/4 1 0]);
[breaks,coefs,l,k,d] = unmkpp(pp)
```

```
breaks =
 -8 -4
```

```
coefs =
 -0.2500 1.0000 0
```

```
l =
 1
```

```
k =
 3
```

```
d =
 1
```

**See Also** `mkpp` | `ppval` | `spline`

# unregisterallevents

---

**Purpose** Unregister all event handlers associated with COM object events at run time

**Syntax** `h.unregisterallevents`  
`unregisterallevents(h)`

**Description** `h.unregisterallevents` unregisters all events previously registered with COM object `h`. After calling `unregisterallevents`, the object no longer responds to any events until you register them again using the `registerevent` function.

`unregisterallevents(h)` is an alternate syntax.

COM functions are available on Microsoft Windows systems only.

**Examples** Register and unregister events for an instance of the `mwsamp` control, using the `eventlisteners` function to see the event handler associated with each event:

**1** Register three events and their respective handler routines.

```
f = figure ('position', [100 200 200 200]);
h = actxcontrol('mwsamp.mwsampctrl.2', ...
 [0 0 200 200], f, ...
 {'Click' 'myclick'; 'Db1Click' 'my2click'; ...
 'MouseDown' 'mymoused'});
h.eventlisteners
```

```
ans =
 'click' 'myclick'
 'dblclick' 'my2click'
 'mousedown' 'mymoused'
```

**2** Unregister all events simultaneously with `unregisterallevents`. `eventlisteners` returns an empty cell array, indicating that there are no longer any events registered with the control:

```
h.unregisterallevents;
```



```
h.eventlisteners
```

```
ans =
 {}
```

## See Also

```
events (COM) | eventlisteners | registerevent | unregisterevent
| isevent
```

# unregisterevent

---

**Purpose** Unregister event handler associated with COM object event at run time

**Syntax** `h.unregisterevent(eventhandler)`  
`unregisterevent(h, eventhandler)`

**Description** `h.unregisterevent(eventhandler)` unregisters specific event handler routines from their corresponding events. Once you unregister an event, the object no longer responds to the event.

`unregisterevent(h, eventhandler)` is an alternate syntax.

You can unregister events at any time after creating a control. The `eventhandler` argument, which is a cell array, specifies both events and event handlers.

```
h.unregisterevent({'event_name', @event_handler});
```

Specify events in the `eventhandler` argument using the names of the events. Strings used in the `eventhandler` argument are not case sensitive. `unregisterevent` does not accept numeric event identifiers.

COM functions are available on Microsoft Windows systems only.

**Examples** Unregister events for a control:

- 1 Create an `mwsamp` control and register all events with the same handler routine, `sampev`. Use `eventlisteners` to see the event handler used by each event. In this case, each event, when fired, calls `sampev.m`:

```
f = figure('position', [100 200 200 200]);
h = actxcontrol('mwsamp.mwsampctrl.2', ...
 [0 0 200 200], f, ...
 'sampev');
h.eventlisteners
```

```
ans =
```

```
'Click' 'sampev'
'DbClick' 'sampev'
'MouseDown' 'sampev'
'Event_Args' 'sampev'
```

- 2** Unregister just the `dblclick` event. Now, when you list the registered events using `eventlisteners`, `dblclick` is no longer registered and the control does not respond when you double-click the mouse over it:

```
h.unregisterevent({'dblclick' 'sampev'});
h.eventlisteners
```

```
ans =
 'Click' 'sampev'
 'MouseDown' 'sampev'
 'Event_Args' 'sampev'
```

- 3** Now, register the `click` and `dblclick` events with a different event handler for `myclick` and `my2click`, respectively:

```
h.unregisterallevents;
h.registerevent({'click' 'myclick'; ...
 'dblclick' 'my2click'});
h.eventlisteners
```

```
ans =
 'click' 'myclick'
 'dblclick' 'my2click'
```

- 4** Unregister these same events by specifying event names and their handler routines in a cell array. `eventlisteners` now returns an empty cell array, meaning that no events are registered for the `mwsamp` control:

```
h.unregisterevent({'click' 'myclick'; ...
 'dblclick' 'my2click'});
h.eventlisteners
```

# unregisterevent

---

```
ans =
 {}
```

---

Unregister Microsoft Excel workbook events:

- 1 Create a Workbook object and register two events with the event handler routines, `EvtActivateHndlr` and `EvtDeactivateHndlr`:

```
myApp = actxserver('Excel.Application');
wbs = myApp.Workbooks;
wb = wbs.Add;wb.registerevent({'Activate' 'EvtActivateHndlr'; ...
 'Deactivate' 'EvtDeactivateHndlr'})
wb.eventlisteners
```

```
ans =
 'Activate' 'EvtActivateHndlr'
 'Deactivate' 'EvtDeactivateHndlr'
```

MATLAB shows the events with the corresponding event handlers.

- 2 Next, unregister the `Deactivate` event handler:

```
wb.unregisterevent({'Deactivate' 'EvtDeactivateHndlr'})
wb.eventlisteners
```

```
ans =
 'Activate' 'EvtActivateHndlr'
```

MATLAB shows the remaining registered event (`Activate`) with its corresponding event handler.

## See Also

[events \(COM\)](#) | [eventlisteners](#) | [registerevent](#) | [unregisterallevents](#) | [isevent](#)

## How To

- “Writing Event Handlers”

**Purpose**

Unstack data from single variable into multiple variables

**Syntax**

```
W = unstack(T,vars,ivar)
W = unstack(T,vars,ivar,Name,Value)
[W,it] = stack(___)
```

**Description**

`W = unstack(T,vars,ivar)` converts the tall table, `T`, to an equivalent table, `W`, that is in wide format. `unstack` unstacks a single variable in `T`, specified by `vars`, into multiple variables in `W`. In general, `W` contains more variables, but fewer rows, than `T`.

An indicator variable in `T`, specified by `ivar`, determines which variable in `W` contains each value in `var` after it is unstacked. `unstack` treats the remaining variables in `T` as grouping variables. Each unique combination of values in the grouping variables identifies a group of rows in `T` that will be unstacked into a single row of `W`.

`W = unstack(T,vars,ivar,Name,Value)` converts the table `T` to wide format with additional options specified by one or more `Name,Value` pair arguments.

For example, you can specify how `unstack` converts variables from `T` to variables in `W`.

`[W,it] = stack( ___ )` also returns an index vector, `it`, indicating the correspondence between rows in `W` and rows in `T`. You can use any of the previous input arguments.

**Input Arguments****T - Tall table**

table

Tall table, specified as a table. `T` must contain data variables to unstack, `vars`, and an indicator variable, `ivars`. The remaining variables in `T` are either grouping variables or constant variables.

**vars - Variables in T to unstack**

positive integer | vector of positive integers | variable name | cell array of variable names | logical vector

Variables in  $T$  to unstack, specified as a positive integer, vector of positive integers, variable name, cell array of variable names, or logical vector.

### **ivar - Indicator variable in T**

positive integer | variable name

Indicator variable in  $T$ , specified as a positive integer or a variable name. The variable specified by `ivar` indicates which variable in  $W$  each value in `var` is unstacked into.

`ivar` can be a numeric vector, logical vector, character array, cell array of strings, or categorical vector.

### **Name-Value Pair Arguments**

Specify optional comma-separated pairs of `Name`, `Value` arguments. `Name` is the argument name and `Value` is the corresponding value. `Name` must appear inside single quotes (' '). You can specify several name and value pair arguments in any order as `Name1, Value1, ..., NameN, ValueN`.

**Example:** `'AggregationFunction', @mean` applies the aggregation function `@mean` to the values in `vars`.

### **'GroupingVariables' - Grouping variables in T that define groups of rows**

positive integer | vector of positive integers | variable name | cell array of variable names | logical vector

Grouping variables in  $T$  that define groups of rows, specified as the comma-separated pair consisting of `'GroupingVariables'` and a positive integer, vector of positive integers, variable name, cell array of variable names, or logical vector. Each group of rows in  $T$  becomes one row in  $W$ .

The default is all the variables in  $T$  not listed in `vars` or `ivar`.

**'ConstantVariables' - Variables constant within a group**

positive integer | vector of positive integers | variable name | cell array of variable names | logical vector

Variables constant within a group, specified as the comma-separated pair consisting of 'ConstantVariables' and a positive integer, vector of positive integers, variable name, cell array of variable names, or logical vector. The default is no variables.

The values for these variables in W are taken from the first row in each group in T.

**'NewDataVariableNames' - Names for new data variables in W**

cell array of strings

Names for new data variables in W, specified as the comma-separated pair consisting of 'NewDataVariableNames' and a cell array of strings. The default is strings based on the values of the grouping variable specified in `ivar`.

**'AggregationFunction' - Aggregation function from values in vars to single value**

function handle

Aggregation function from values in `vars` to single value, specified as the comma-separated pair consisting of 'AggregationFunction' and a function handle. `unstack` applies this function to rows from the same group that have the same value in `ivar`. The function must aggregate the data values into a single value.

For a numeric data variable, the default is `@sum`. For nonnumeric variables, there is no default function, and you must specify the 'AggregationFunction' name-value pair argument if multiple rows in the same group have the same value in `ivar`.

## Output Arguments

### **W - Wide table**

table

Wide table, returned as a table. *W* contains the unstacked data variables, the grouping variables, and the first value of each group from any constant variables.

The order of the data in *W* is based on the order of the unique values in the grouping variables.

You can store additional metadata such as descriptions, variable units, variable names, and row names in the table. For more information, see [Table Properties](#).

### **it - Index to T**

column vector

Index to *T*, returned as a column vector. For each row in *W*, the index vector, *it*, identifies the index of the first value in the corresponding group of rows in *T*.

## Examples

### **Separate One Variable into Three Variables**

Create a table indicating the amount of snowfall in various towns for various storms.

```
Storm = [3;3;1;3;1;1;4;2;4;2;4;2];
Town = {'T1';'T3';'T1';'T2';'T2';'T3';...
 'T2';'T1';'T3';'T3';'T1';'T2'};
Snowfall = [0;3;5;5;9;10;12;13;15;16;17;21];
```

```
T = table(Storm,Town,Snowfall)
```

```
T =
```

Storm	Town	Snowfall
3	'T1'	0



3	'T3'	3
1	'T1'	5
3	'T2'	5
1	'T2'	9
1	'T3'	10
4	'T2'	12
2	'T1'	13
4	'T3'	15
2	'T3'	16
4	'T1'	17
2	'T2'	21

T contains three snowfall entries for each storm, one for each town.

Separate the variable `Snowfall` into three variables, one for each town specified in the variable, `Town`.

```
W = unstack(T, 'Snowfall', 'Town')
```

W =

Storm	T1	T2	T3
3	0	5	3
1	5	9	10
4	17	12	15
2	13	21	16

Each row in `W` contains data from rows in `T` that have the same value in the grouping variable, `Storm`. The order of the unique values in `Storm` determines the order of the data in `W`.

### Apply Aggregation Function to Each Group

Unstack data and apply an aggregation function to multiple rows in the same group that have the same values in the indicator variable.

Create a table containing data on the price of two stocks over 2 days.

# unstack

---

```
Date = [repmat({'4/12/2008'},6,1);...
 repmat({'4/13/2008'},5,1)];
Stock = {'Stock1','Stock2','Stock1','Stock2';...
 'Stock2','Stock2','Stock1','Stock2';...
 'Stock2','Stock1','Stock2'};
Price = [60.35;27.68;64.19;25.47;28.11;27.98;...
 63.85;27.55;26.43;65.73;25.94];
```

```
T = table(Date,Stock,Price)
```

```
T =
```

Date	Stock	Price
'4/12/2008'	'Stock1'	60.35
'4/12/2008'	'Stock2'	27.68
'4/12/2008'	'Stock1'	64.19
'4/12/2008'	'Stock2'	25.47
'4/12/2008'	'Stock2'	28.11
'4/12/2008'	'Stock2'	27.98
'4/13/2008'	'Stock1'	63.85
'4/13/2008'	'Stock2'	27.55
'4/13/2008'	'Stock2'	26.43
'4/13/2008'	'Stock1'	65.73
'4/13/2008'	'Stock2'	25.94

T contains two prices for STOCK1 during the first day and four prices for STOCK2 during the first day.

Create a table containing separate variables for each stock and one row for each day. Use Date as the grouping variable and apply the aggregation function, @mean, to the numeric values from the variable, Price, for each group.

```
[W,it] = unstack(T,'Price','Stock',...
 'AggregationFunction',@mean)
```

W =

Date	Stock1	Stock2
'4/12/2008'	62.27	27.31
'4/13/2008'	64.79	26.64

it =

1  
7

W contains the average price for each stock grouped by date.

it identifies the index of the first value for each group of rows in T. The first value for the group '4/13/2008' is in the seventh row of T.

## Tips

- You can specify more than one data variable in T, and each variable becomes a set of unstacked data variables in W. Use a vector of positive integers, a cell array containing multiple variable names, or a logical vector to specify vars. The one indicator variable, specified by the input argument, ivar, applies to all data variables specified by vars.

## Definitions

### Grouping Variables

Grouping variables are utility variables used to group, or categorize, data. Grouping variables are useful for summarizing or visualizing data by group. You can define groups in your table by specifying one or more grouping variables.

A grouping variable can be any of the following:

- Categorical vector
- Cell array of strings
- Character array

# unstack

---

- Numeric vector, typically containing positive integers
- Logical vector

Rows that have the same grouping variable value belong to the same group. If you use multiple grouping variables, rows that have the same combination of grouping variable values belong to the same group.

## See Also

`stack` | `join`

**Purpose**

Extract contents of tar file

**Syntax**

```
untar(tarfilename)
untar(tarfilename,outputdir)
untar(url, ___)
filenames = untar(___)
```

**Description**

`untar(tarfilename)` extracts the archived contents of `tarfilename` into the current directory and sets the files' attributes. It overwrites any existing files with the same names as those in the archive if the existing files' attributes and ownerships permit it. For example, if you rerun `untar` on the same `tarfilename`, MATLAB software does not overwrite files with a read-only attribute; instead, `untar` displays a warning for such files. On Microsoft Windows platforms, the hidden, system, and archive attributes are not set.

`tarfilename` is a string specifying the name of the tar file. `tarfilename` is gunzipped to a temporary directory and deleted if its extension ends in `.tgz` or `.gz`. If an extension is omitted, `untar` searches for `tarfilename` appended with `.tgz`, `.tar.gz`, or `.tar`. `tarfilename` can include the directory name; otherwise, the file must be in the current directory or in a directory on the MATLAB path.

`untar(tarfilename,outputdir)` uncompresses the archive `tarfilename` into the directory `outputdir`. If `outputdir` does not exist, MATLAB creates it.

`untar(url, ___)` extracts the tar archive from an Internet URL. The URL must include the protocol type (for example, `'http://'` or `'ftp://'`). MATLAB downloads the URL to a temporary directory, and then deletes it.

`filenames = untar( ___)` extracts the tar archive and returns the names of the extracted files in the string cell array `filenames`. If `outputdir` specifies a relative path, `filenames` contains the relative path. If `outputdir` specifies an absolute path, `filenames` contains the absolute path.

## Examples

### Using tar and untar to Copy Files

Copy all .m files in the current directory to the directory backup.

```
tar('myfiles.tar.gz','*.m');
untar('myfiles','backup');
```

### Using untar with URL

Run untar to list Cleve Moler's "Numerical Computing with MATLAB" examples to the output directory ncm.

```
url = 'http://www.mathworks.com/moler/ncm.tar.gz';
ncmFiles = untar(url,'ncm')
```

## See Also

gzip | gunzip | tar | unzip | zip

**Purpose** Correct phase angles to produce smoother phase plots

**Syntax**

```
Q = unwrap(P)
Q = unwrap(P,tol)
Q = unwrap(P,[],dim)
Q = unwrap(P,tol,dim)
```

**Description** `Q = unwrap(P)` corrects the radian phase angles in a vector `P` by adding multiples of  $\pm 2\pi$  when absolute jumps between consecutive elements of `P` are greater than or equal to the default jump tolerance of  $\pi$  radians. If `P` is a matrix, `unwrap` operates columnwise. If `P` is a multidimensional array, `unwrap` operates on the first nonsingleton dimension.

`Q = unwrap(P,tol)` uses a jump tolerance `tol` instead of the default value,  $\pi$ .

`Q = unwrap(P,[],dim)` unwraps along `dim` using the default tolerance.

`Q = unwrap(P,tol,dim)` uses a jump tolerance of `tol`.

---

**Note** A jump tolerance less than  $\pi$  has the same effect as a tolerance of  $\pi$ . For a tolerance less than  $\pi$ , if a jump is greater than the tolerance but less than  $\pi$ , adding  $\pm 2\pi$  would result in a jump larger than the existing one, so `unwrap` chooses the current point. If you want to eliminate jumps that are less than  $\pi$ , try using a finer grid in the domain.

---

## Examples

### Example 1

The following phase data comes from the frequency response of a third-order transfer function. The phase curve jumps 3.5873 radians between  $w = 3.0$  and  $w = 3.5$ , from -1.8621 to 1.7252.

```
w = [0:.2:3,3.5:1:10];
p = [0
 -1.5728
 -1.5747
 -1.5772
```

```
-1.5790
-1.5816
-1.5852
-1.5877
-1.5922
-1.5976
-1.6044
-1.6129
-1.6269
-1.6512
-1.6998
-1.8621
1.7252
1.6124
1.5930
1.5916
1.5708
1.5708
1.5708];
semilogx(w,p,'b*-'), hold
```



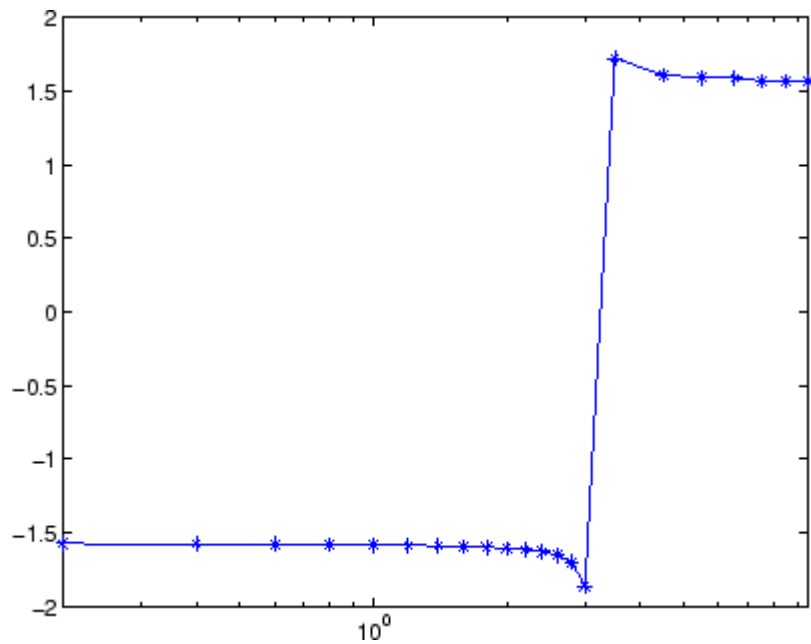

Using `unwrap` to correct the phase angle, the resulting jump is 2.6959, which is less than the default jump tolerance  $\pi$ . This figure plots the new curve over the original curve.

```
semilogx(w,unwrap(p),'r*-')
```

# unwrap

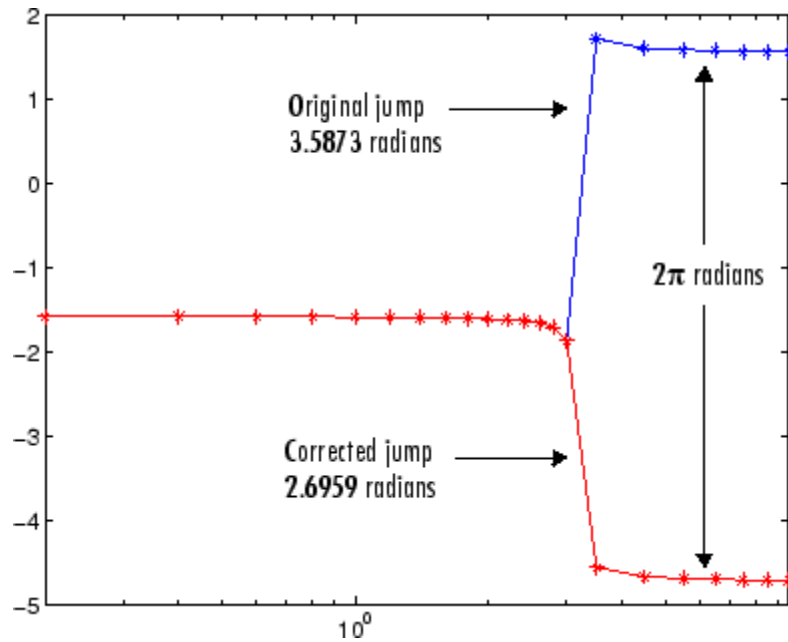

## Example 2

Array P features smoothly increasing phase angles except for discontinuities at elements (3,1) and (1,2).

```
P = [0 7.0686 1.5708 2.3562
 0.1963 0.9817 1.7671 2.5525
 6.6759 1.1781 1.9635 2.7489
 0.5890 1.3744 2.1598 2.9452]
```

The function  $Q = \text{unwrap}(P)$  eliminates these discontinuities.

```
Q =
 0 7.0686 1.5708 2.3562
 0.1963 7.2649 1.7671 2.5525
 0.3927 7.4613 1.9635 2.7489
 0.5890 7.6576 2.1598 2.9452
```

**See Also**

abs | angle

# unzip

---

## Purpose

Extract contents of zip file

## Syntax

```
unzip(zipfilename)
unzip(zipfilename,outputdir)
filenames = unzip(zipfilename,outputdir)
```

## Description

`unzip(zipfilename)` extracts the archived contents of `zipfilename` into the current folder, preserving the files' attributes and timestamps. The `unzip` function can extract files from your local system or files from an Internet URL.

`unzip(zipfilename,outputdir)` extracts the contents of `zipfilename` into the folder `outputdir`.

`filenames = unzip(zipfilename,outputdir)` returns the names of the extracted files in the string cell array `filenames`. Specifying `outputdir` is optional.

## Tips

- `unzip` does not support password-protected or encrypted zip archives.
- If any files in the target folder have the same name as files in the zip file, and you have write permission to the files, `unzip` overwrites the existing files with the archived versions. If you do not have write permission, `unzip` issues a warning.
- Extract files that contain non-7-bit ASCII characters on a machine that has the appropriate language/encoding settings.

## Input Arguments

### **zipfilename**

String that specifies the name of the zip file.

If `zipfilename` does not include the full path, `unzip` searches for the file in the current folder and along the MATLAB path. If you do not specify the file extension, `unzip` appends `.zip`.

If you are downloading a URL, `zipfilename` must include the protocol type (for example, `http://`). The `unzip` function downloads the URL to the temporary folder on your system, and deletes the URL on cleanup.

**outputdir**

String that specifies the target folder for the extracted files.

**Default:** current folder ('.')

**Output Arguments****entrynames**

Cell array of strings that contain the paths of the extracted files.

If `outputdir` specifies a relative path, `filenames` contains the relative path. If `outputdir` specifies an absolute path, `filenames` contains the absolute path.

**Examples**

Copy the example MAT-files to the folder archive:

```
% Zip the example MAT-files to examples.zip
zip('examples.zip','*.mat',...
 fullfile(matlabroot,'toolbox','matlab','demos'))
```

```
% Unzip examples.zip to the folder 'archive'
unzip('examples','archive')
```

---

Download Cleve Moler's "Numerical Computing with MATLAB" examples to the output folder ncm:

```
url = 'http://www.mathworks.com/moler/ncm.zip';
ncmFiles = unzip(url,'ncm')
```

**Alternatives**

To extract files from a zip file using the Current Folder browser, select the zip file, right-click to open the context menu, and then select **Extract**.

**See Also**

`fileattrib` | `gzip` | `gunzip` | `tar` | `untar` | `zip`

# uplus, +

---

**Purpose** Unary plus

**Syntax**  
C = +A  
C = uplus(A)

**Description** C = +A returns array A and stores it in C.

C = uplus(A) is an alternate way to execute +A, but is rarely used. It enables operator overloading for classes.

**Input Arguments** **A - Input array**  
scalar | vector | matrix | multidimensional array  
Input array, specified as a scalar, vector, matrix, or multidimensional array.

**Data Types**  
single | double | int8 | int16 | int32 | int64 | uint8 |  
uint16 | uint32 | uint64 | logical | char  
**Complex Number Support:** Yes

**Examples** **Unary Plus of Matrix**

Create a 2-by-2 matrix, A.

```
A = [1 -3; -2 4]
```

```
A =
```

```
 1 -3
 -2 4
```

Use unary plus on A.

```
C = +A
```

```
C =
```

1 -3  
-2 4

C and A are the same.

**See Also**

uminus | plus

# upper

---

**Purpose** Convert string to uppercase

**Syntax** `t = upper('str')`  
`B = upper(A)`

**Description** `t = upper('str')` converts any lowercase characters in the string `str` to the corresponding uppercase characters and leaves all other characters unchanged.

`B = upper(A)` when `A` is a cell array of strings, returns a cell array the same size as `A` containing the result of applying `upper` to each string within `A`.

**Examples** `upper('attention!')` is ATTENTION!.

**Tips** Character sets supported:

- PC: Windows Latin-1
- Other: ISO Latin-1 (ISO 8859-1)

**See Also** `lower`



**Purpose** Download URL content to MATLAB string

**Syntax**

```
str = urlread(URL)
str = urlread(URL,Name,Value)
[str,status] = urlread(___)
```

**Description** `str = urlread(URL)` downloads the HTML Web content from the specified URL into the string `str`. `urlread` does not retrieve hyperlink targets and images.

`str = urlread(URL,Name,Value)` uses additional options specified by one or more `Name,Value` pair arguments.

`[str,status] = urlread( ___ )` suppresses the display of error messages, using any of the input arguments in the previous syntaxes. When the operation is successful, `status` is 1. Otherwise, `status` is 0

## Input Arguments

### URL - Content location

string

Content location, specified as a string. Include the transfer protocol, such as `http`, `ftp`, or `file`.

**Example:** `'http://www.mathworks.com/matlabcentral'`

### Name-Value Pair Arguments

Specify optional comma-separated pairs of `Name,Value` arguments. `Name` is the argument name and `Value` is the corresponding value. `Name` must appear inside single quotes ( `' '` ). You can specify several name and value pair arguments in any order as `Name1,Value1,...,NameN,ValueN`.

**Example:** `'Timeout',10,'Charset','UTF-8'` specifies that `urlread` should time out after 10 seconds, and the character encoding of the file is UTF-8.

### 'Get' - Data to send to the Web form using the GET method

cell array

Parameters of the data to send to the Web form using the GET method, specified as the comma-separated pair consisting of 'get' and a cell array of paired parameter names and values. The supported parameters depend upon the URL.

'Get' includes the data in the URL, separated by ? and & characters.

**Example:** 'Get', {'term', 'urlread'}

## **'Post' - Data to send to the Web form using the POST method**

cell array

Parameters of the data to send to the Web form using the POST method, specified as the comma-separated pair consisting of 'post' and a cell array of paired parameter names and values. The supported parameters depend upon the URL.

'Post' submits the data as part of the request headers, not explicitly in the URL.

## **'Charset' - Character encoding**

string

Character encoding, specified as the comma-separated pair consisting of 'Charset' and a string. If you do not specify Charset, the function attempts to determine the character encoding from the headers of the file. If the character encoding cannot be determined, Charset defaults to the native encoding for the file protocol, and UTF-8 for all other protocols.

**Example:** 'Charset', 'ISO-8859-1'

## **'Timeout' - Timeout duration**

scalar

Timeout duration in seconds, specified as the comma-separated pair consisting of 'Timeout' and a scalar. The timeout duration determines when the function errors rather than continues to wait for the server to respond or send data.

**Example:** 'Timeout',10

### **'UserAgent' - Client user agent identification**

string

Client user agent identification, specified as the comma-separated pair consisting of 'UserAgent' and a string.

**Example:** 'UserAgent', 'MATLAB R2012b'

### **'Authentication' - HTTP authentication mechanism**

'Basic'

HTTP authentication mechanism, specified as the comma-separated pair consisting of 'Authentication' and a string. Currently, only the value 'Basic' is supported. 'Authentication', 'Basic' specifies basic authentication.

If you include the Authentication argument, you must also include the Username and Password arguments.

### **'Username' - User identifier**

string

User identifier, specified as the comma-separated pair consisting of 'Username' and a string. If you include the Username argument, you must also include the Password and Authentication arguments.

**Example:** 'Username', 'myName'

### **'Password' - User authentication password**

string

User authentication password, specified as the comma-separated pair consisting of 'Password' and a string. If you include the Password argument, you must also include the Username and Authentication arguments.

**Example:** 'Password', 'myPassword123'

# urlread

---

## Output Arguments

### **str - Contents of the file at the specified URL**

string

Contents of the file at the specified URL, returned as a string. For example, if the URL corresponds to an HTML page, `str` contains the text and markup in the HTML file. If the URL corresponds to a binary file, `str` is not readable.

### **status - Download status**

1 | 0

Download status, returned as either 1 or 0. When the download is successful, `status` is 1. Otherwise, `status` is 0.

## Examples

### **Download Web Content by Specifying Complete URL**

Download the HTML for the page on the MATLAB Central File Exchange that lists submissions related to `urlread`.

```
fullURL = ['http://www.mathworks.com/matlabcentral/fileexchange' ...
 '?term=urlread'];
str = urlread(fullURL);
```

`urlread` reads from the specified URL and downloads the HTML content to the string `str`.

### **Download Web Content Related to a Term**

Download the HTML for the page on the MATLAB Central File Exchange that lists submissions related to `urlread`.

```
URL = 'http://www.mathworks.com/matlabcentral/fileexchange';
str = urlread(URL, 'Get', {'term', 'urlread'});
```

`urlread` reads from `http://www.mathworks.com/matlabcentral/fileexchange/?term=urlread` and downloads the HTML content to the string `str`.

### Specify Timeout Duration

Download content from a page on the MATLAB Central File Exchange as in the first example, and specify a timeout duration of 5 seconds.

```
fullURL = ['http://www.mathworks.com/matlabcentral/fileexchange' ...
 '?term=urlread'];
str = urlread(fullURL,'Timeout',5);
```

### Tips

- urlread saves Web content to a string. To save content to a file, use urlwrite.
- urlread and urlwrite can download content from FTP sites. Alternatively, use the ftp function to connect to an FTP server and the mget function to download a file.

### See Also

urlwrite | ftp | web | mget

### Concepts

- “Specify Proxy Server Settings for Connecting to the Internet”

# urlwrite

---

**Purpose** Download URL content and save to file

**Syntax** `urlwrite(URL,filename)`  
`urlwrite(URL,filename,Name,Value)`  
  
`[filestr,status] = urlwrite( __ )`

**Description** `urlwrite(URL,filename)` reads Web content at the specified URL and saves it to the file specified by `filename`.

`urlwrite(URL,filename,Name,Value)` uses additional options specified by one or more `Name,Value` pair arguments.

`[filestr,status] = urlwrite( __ )` stores the file path in variable `filestr`, and suppresses the display of error messages, using any of the input arguments in the previous syntaxes. When the operation is successful, `status` is 1. Otherwise, `status` is 0.

## Input Arguments

### **URL - Content location**

string

Content location, specified as a string. Include the transfer protocol, such as `http`, `ftp`, or `file`.

**Example:** `'http://www.mathworks.com/matlabcentral'`

### **filename - Name of file to store Web content**

string

Name of the file to store the Web content, specified as a string. If you do not specify the path for `filename`, `urlwrite` saves the file in the current folder.

**Example:** `'myfile.html'`

## **Name-Value Pair Arguments**

Specify optional comma-separated pairs of `Name`, `Value` arguments. `Name` is the argument name and `Value` is the corresponding value. `Name` must appear inside single quotes ( `' '` ). You can specify several name and value pair arguments in any order as `Name1,Value1,...,NameN,ValueN`.

**Example:** `'Timeout',10,'Charset','UTF-8'` specifies that `urlread` should time out after 10 seconds, and the character encoding of the file is UTF-8.

## **'Get' - Data to send to the Web form using the GET method**

cell array

Parameters of the data to send to the Web form using the GET method, specified as the comma-separated pair consisting of `'get'` and a cell array of paired parameter names and values. The supported parameters depend upon the URL.

`'Get'` includes the data in the URL, separated by `?` and `&` characters.

**Example:** `'Get',{'term','urlread'}`

## **'Post' - Data to send to the Web form using the POST method**

cell array

Parameters of the data to send to the Web form using the POST method, specified as the comma-separated pair consisting of `'post'` and a cell array of paired parameter names and values. The supported parameters depend upon the URL.

`'Post'` submits the data as part of the request headers, not explicitly in the URL.

## **'Charset' - Character encoding**

string

Character encoding, specified as the comma-separated pair consisting of `'Charset'` and a string. If you do not specify `Charset`, the function attempts to determine the character encoding from the headers of the

file. If the character encoding cannot be determined, Charset defaults to the native encoding for the file protocol, and UTF-8 for all other protocols.

**Example:** 'Charset', 'ISO-8859-1'

## **'Timeout' - Timeout duration**

scalar

Timeout duration in seconds, specified as the comma-separated pair consisting of 'Timeout' and a scalar. The timeout duration determines when the function errors rather than continues to wait for the server to respond or send data.

**Example:** 'Timeout', 10

## **'UserAgent' - Client user agent identification**

string

Client user agent identification, specified as the comma-separated pair consisting of 'UserAgent' and a string.

**Example:** 'UserAgent', 'MATLAB R2012b'

## **'Authentication' - HTTP authentication mechanism**

'Basic'

HTTP authentication mechanism, specified as the comma-separated pair consisting of 'Authentication' and a string. Currently, only the value 'Basic' is supported. 'Authentication', 'Basic' specifies basic authentication.

If you include the Authentication argument, you must also include the Username and Password arguments.

## **'Username' - User identifier**

string

User identifier, specified as the comma-separated pair consisting of 'Username' and a string. If you include the Username argument, you must also include the Password and Authentication arguments.



**Example:** 'Username', 'myName'

### **'Password' - User authentication password**

string

User authentication password, specified as the comma-separated pair consisting of 'Password' and a string. If you include the Password argument, you must also include the Username and Authentication arguments.

**Example:** 'Password', 'myPassword123'

## **Output Arguments**

### **filestr - Path of the file**

string

Path of the file specified by filename, returned as a string.

### **status - Download status**

1 | 0

Download status, returned as either 1 or 0. When the download is successful, status is 1. Otherwise, status is 0.

## **Examples**

### **Download Web Content by Specifying Complete URL**

Download the HTML for the page on the MATLAB Central File Exchange that lists submissions related to urlwrite. Save the results to samples.html in the current directory.

```
fullURL = ['http://www.mathworks.com/matlabcentral/fileexchange' ...
 '?term=urlwrite'];
filename = 'samples.html';
urlwrite(fullURL,filename);
```

View the file.

```
web(filename)
```

## Download Web Content Related to a Term

Download the HTML for the page on the MATLAB Central File Exchange that lists submissions related to `urlwrite`. Save the results to `samples.html` in the current directory.

```
URL = 'http://www.mathworks.com/matlabcentral/fileexchange';
filename = 'samples.html';
urlwrite(URL,filename,'get',{'term','urlwrite'});
```

`urlwrite` downloads the HTML content from `http://www.mathworks.com/matlabcentral/fileexchange/?term=urlwrite` and writes it to `samples.html`.

## Specify Timeout Duration

Download content from a page on the MATLAB Central File Exchange as in the first example, and specify a timeout duration of 5 seconds.

```
fullURL = ['http://www.mathworks.com/matlabcentral/fileexchange' ...
 '?term=urlwrite'];
filename = 'samples.html';
urlwrite(fullURL,filename,'Timeout',5);
```

### Tips

- `urlread` and `urlwrite` can download content from FTP sites. Alternatively, use the `ftp` function to connect to an FTP server and the `mget` function to download a file.

### See Also

`urlread` | `mget` | `web` | `ftp`

### Concepts

- “Specify Proxy Server Settings for Connecting to the Internet”

<b>Purpose</b>	Determine if Java feature is available								
<b>Syntax</b>	<code>tf = usejava(feature)</code>								
<b>Description</b>	<code>tf = usejava(feature)</code> returns logical 1 (true) if the specified feature is supported. Otherwise, it returns logical 0 (false). Use for error handling if Java feature is unavailable.								
<b>Input Arguments</b>	<p><b>feature - Java feature</b> 'awt'   'desktop'   'jvm'   'swing'</p> <p>Java feature, specified as one of these values:</p> <table><tr><td>'awt'</td><td>Java GUI components in the Abstract Window Toolkit (AWT) components are available.</td></tr><tr><td>'desktop'</td><td>MATLAB interactive desktop is running.</td></tr><tr><td>'jvm'</td><td>Java Virtual Machine software (JVM) is running.</td></tr><tr><td>'swing'</td><td>Swing components (Java lightweight GUI components in the Java Foundation Classes) are available.</td></tr></table>	'awt'	Java GUI components in the Abstract Window Toolkit (AWT) components are available.	'desktop'	MATLAB interactive desktop is running.	'jvm'	Java Virtual Machine software (JVM) is running.	'swing'	Swing components (Java lightweight GUI components in the Java Foundation Classes) are available.
'awt'	Java GUI components in the Abstract Window Toolkit (AWT) components are available.								
'desktop'	MATLAB interactive desktop is running.								
'jvm'	Java Virtual Machine software (JVM) is running.								
'swing'	Swing components (Java lightweight GUI components in the Java Foundation Classes) are available.								
<b>Examples</b>	<p><b>Display Error Message</b></p> <p>Use the following code snippet to test that the AWT GUI components are available before attempting to display a Java Frame.</p> <pre>if usejava('awt')     myFrame = java.awt.Frame; else     disp('Unable to open a Java Frame'); end</pre>								

If the AWT is not available on your system, MATLAB displays the message.

## Call error Function

Use the following code snippet to terminate a script if MATLAB does not have access to JVM software.

The variable, `filename`, is a function that contains Java code.

```
if ~usejava('jvm')
 error([filename ' requires Java to run.']);
end
```

## See Also

`javachk` | `error`

## Concepts

- “Bringing Java Classes into MATLAB Workspace”

**Purpose** View or change user portion of search path

**Syntax** `userpath`

```
userpath(newpath)
userpath('reset')
userpath('clear')
```

**Description** `userpath` returns a string specifying the first folder on the search path. MATLAB adds the *userpath* to the search path upon startup.

`userpath(newpath)` sets the primary *userpath* folder to `newpath`. The `newpath` folder appears at the top of the search path immediately and at startup in future sessions. MATLAB removes the folder previously specified by *userpath* from the search path.

`userpath('reset')` sets the primary *userpath* folder to the default for that platform, creating the Documents/MATLAB (or My Documents/MATLAB) folder, if it does not exist. MATLAB immediately adds the default folder to the top of the search path, and also adds it to the search path at startup in future sessions. On Linux, the MATLAB directory is not created if the Documents directory does not exist.

`userpath('clear')` clears the value for the primary *userpath* immediately, and for future MATLAB sessions. MATLAB removes the folder previously specified by *userpath* from the search path.

## Input Arguments

### **newpath - New userpath value**

string

New userpath value, specified as a string. `newpath` must be an absolute path.

**Example:** 'C:\myFolder'

## Examples

### View userpath Folder

This example assumes *userpath* is set to the default value on the Windows XP platform, My Documents\MATLAB. Start MATLAB and display the current folder:

```
pwd
```

```
H:\My Documents\MATLAB
```

In this example, H is the drive at which My Documents is located.

Confirm that the current folder is the *userpath*.

```
userpath
```

```
H:\My Documents\MATLAB;
```

Display the search path.

```
path
```

```
MATLABPATH
```

```
H:\My Documents\MATLAB
C:\Program Files\MATLAB\R2009a\toolbox\matlab\general
C:\Program Files\MATLAB\R2009a\toolbox\matlab\ops
...
```

MATLAB returns the search path. The *userpath* portion is at the top.

### Set New Value for userpath

Assume *userpath* is set to the default value on the Windows XP platform, My Documents\MATLAB. Change the value from the default for *userpath* to C:\Research\_Project.

```
newpath = 'C:\Research_Project';
userpath(newpath)
```

View the effect of the change on the search path.

```
path
```

```
MATLABPATH
```

```
C:\Research_Project
C:\Program Files\MATLAB\R2009a\toolbox\matlab\general
C:\Program Files\MATLAB\R2009a\toolbox\matlab\ops
...
```

MATLAB displays the search path, with the new value for *userpath* portion at the top. Note that MATLAB automatically removed the previous value of *userpath*, H:\My Documents\MATLAB, from the search path when you assigned a new value to *userpath*.

### **Clear the Value for userpath**

Assume *userpath* is set to the default value and you do not want any folders to be added to the search path upon startup. Confirm the default is currently set.

```
userpath
```

```
H:\My Documents\MATLAB;
```

Verify that the *userpath* folder is at the top of the search path.

```
path
```

```
MATLABPATH
```

```
H:\My Documents\MATLAB
C:\Program Files\MATLAB\R2009a\toolbox\matlab\general
C:\Program Files\MATLAB\R2009a\toolbox\matlab\ops
...
```

Clear the value.

```
userpath('clear')
```

# userpath

---

Verify the result.

```
userpath
```

```
ans =
 ''
```

Confirm the *userpath* folder was removed from the search path.

```
path
```

```
MATLABPATH
```

```
C:\Program Files\MATLAB\R2009a\toolbox\matlab\general
C:\Program Files\MATLAB\R2009a\toolbox\matlab\ops
...
```

---

**Note** By default, the startup folder is the *userpath* folder when you start MATLAB by double-clicking the shortcut on Windows platforms, or by double-clicking the application on Macintosh platforms. If you clear the value for *userpath*, the startup folder will not necessarily be on the search path. Removing the *userpath* folder from the search path *and* saving the changes to the path has the same effect.

---

## Tips

- On Macintosh and UNIX platforms, you can automatically add subfolders to the top of the search path upon startup by specifying the path for the subfolders via the MATLABPATH environment variable.

## See Also

[addpath](#) | [path](#) | [rmpath](#) | [savepath](#) | [startup](#)

## Concepts

- “What Is the MATLAB Search Path?”
- “MATLAB Startup Folder”



## Purpose

Check validity of array

## Syntax

```
validateattributes(A,classes,attributes)
validateattributes(A,classes,attributes,argIndex)
validateattributes(A,classes,attributes,funcName)
validateattributes(A,classes,attributes,funcName,varName)
validateattributes(A,classes,attributes,funcName,varName,argIndex)
```

## Description

`validateattributes(A,classes,attributes)` validates that array `A` belongs to at least one of the specified classes (or its subclass) and has all of the specified attributes. If `A` does not meet the criteria, MATLAB throws an error and displays a formatted error message. Otherwise, `validateattributes` completes without displaying any output.

`validateattributes(A,classes,attributes,argIndex)` includes the position of the input in your function argument list as part of any generated error messages.

`validateattributes(A,classes,attributes,funcName)` includes the specified function name in generated error identifiers.

`validateattributes(A,classes,attributes,funcName,varName)` includes the specified variable name in generated error messages.

`validateattributes(A,classes,attributes,funcName,varName,argIndex)` includes the specified information in generated error messages or identifiers.

## Input Arguments

### **A** - Input

any type of array

Input, specified as any type of array.

# validateattributes

---

## Data Types

single | double | int8 | int16 | int32 | int64 | uint8 |  
uint16 | uint32 | uint64 | logical | char | struct | cell  
| function\_handle

**Complex Number Support:** Yes

## classes - Valid data types

cell array of strings

Valid data types, specified as a cell array of strings. Each string can be the name of any built-in or custom class, including:

'single'	Single-precision number
'double'	Double-precision number
'int8'	Signed 8-bit integer
'int16'	Signed 16-bit integer
'int32'	Signed 32-bit integer
'int64'	Signed 64-bit integer
'uint8'	Unsigned 8-bit integer
'uint16'	Unsigned 16-bit integer
'uint32'	Unsigned 32-bit integer
'uint64'	Unsigned 64-bit integer
'logical'	Logical true or false
'char'	Character or string
'struct'	Structure array
'cell'	Cell array
'function_handle'	function handle

'numeric'	Any data type for which the <code>isa(A, 'numeric')</code> function returns true, including <code>int8</code> , <code>int16</code> , <code>int32</code> , <code>int64</code> , <code>uint8</code> , <code>uint16</code> , <code>uint32</code> , <code>uint64</code> , <code>single</code> , or <code>double</code>
'<class_name>'	Any other class name

## Data Types

`cell`

### attributes - Valid attributes

`cell` array of strings

Valid attributes, specified as a `cell` array of strings.

Some attributes also require numeric values, such as attributes that specify the size or number of elements of `A`. For these attributes, the numeric value or vector must immediately follow the attribute name string in the `cell` array.

Attributes that describe the size and shape of array `A`:

'2d'	Two-dimensional array, including scalars, vectors, matrices, and empty arrays
'3d'	Array with three or fewer dimensions
'column'	Column vector, N-by-1
'row'	Row vector, 1-by-N
'scalar'	Scalar value, 1-by-1
'vector'	Row or column vector, or a scalar value
'size', [d1,...,dN]	Array with dimensions d1-by-...-by-dN. To skip checking a particular dimension, specify NaN for that dimension, such as [3,4,NaN,2].
'numel', N	Array with N elements
'ncols', N	Array with N columns

# validateattributes

---

'nrows', N	Array with N rows
'ndims', N	N-dimensional array
'square'	Square matrix; in other words, a two-dimensional array with equal number of rows and columns
'diag'	Diagonal matrix
'nonempty'	No dimensions that equal zero
'nonsparse'	Array that is not sparse

Attributes that specify valid ranges for values in A:

'>', N	All values greater than N
'>=', N	All values greater than or equal to N
'<', N	All values less than N
'<=', N	All values less than or equal to N

Attributes that check types of values in a numeric or logical array, A:

'binary'	Array of ones and zeros
'even'	Array of even integers (includes zero)
'odd'	Array of odd integers
'integer'	Array of integer values
'real'	Array of real values
'finite'	Array of finite values
'nonnan'	No NaN (Not a Number) elements
'nonnegative'	No elements less than zero
'nonzero'	No elements equal to zero

'positive'	No elements less than or equal to zero
'decreasing'	Each element of a column is less than the previous element and no element is NaN
'increasing'	Each element of a column is greater than the previous element and no element is NaN
'nondecreasing'	Each element of a column is greater than or equal to the previous element and no element is NaN
'nonincreasing'	Each element of a column is less than or equal to the previous element and no element is NaN

## Data Types

cell

### **funcName - Name of function whose input you are validating**

string

Name of function whose input you are validating, specified as a string. If you specify an empty string, '', the validateattribute function ignores the funcName input.

## Data Types

char

### **varName - Name of input variable**

string

Name of input variable, specified as a string. If you specify an empty string, '', the validateattribute function ignores the varName input.

## Data Types

char

### **argIndex - Position of input argument**

positive integer

Position of input argument, specified as a positive integer.

# validateattributes

---

## Data Types

double

## Examples

### Validate the Size of an Array

```
classes = {'numeric'};
attributes = {'size',[4,6,2]};
```

```
A = rand(3,5,2);
validateattributes(A,classes,attributes)
```

Expected input to be of size 4x6x2 when it is actually size 3x5x2.

Because A did not match the specified attributes, MATLAB throws an error message.

### Validate Array Monotonicity

Determine if an array is increasing or nondecreasing.

```
A = [1 5 8 2;
 9 6 9 4]
validateattributes(A, {'double'},{'nondecreasing'})
validateattributes(A, {'double'},{'increasing'})
```

A =

```
 1 5 8 2
 9 6 9 4
```

Since A is both increasing and nondecreasing, `validateattributes` does not throw an error for either attribute check.

Setting `A(2,3)` equal to `A(1,3)` results in a column that is no longer strictly increasing, so `validateattributes` throws an error.

```
A(2,3) = 8
validateattributes(A, {'double'},{'increasing'})
```

A =

```
 1 5 8 2
 9 6 8 4
```

Expected input to be increasing valued.

However, the columns remain nondecreasing since each column element is equal to or greater than the next. The following code does not throw an error.

```
validateattributes(A, {'double'}, {'nondecreasing'})
```

## Check the Attributes of a Complex Number

Assuming that `a` is to be the second input argument to a function, check that it is nonnegative.

```
a = complex(1,1);
validateattributes(a, {'numeric'}, {'nonnegative'}, 2);
```

Expected input number 2 to be nonnegative.

Because complex numbers lack a well-defined ordering in the complex plane, `validateattributes` does not recognize them as positive or negative.

## Ensure Array Values Are Within a Specified Range

Check that the values in an array are 8-bit integers between 0 and 10.

Assume that this code occurs in a function called `Rankings`.

```
classes = {'uint8', 'int8'};
attributes = {'>', 0, '<', 10};
funcName = 'Rankings';
A = int8(magic(4));
```

```
validateattributes(A, classes, attributes, funcName)
```

# validateattributes

---

Error using Rankings

Expected input to be an array with all of the values < 10.

## Validate Function Input Parameters Using inputParser

Create a custom function that checks input parameters with `inputParser`, and use `validateattributes` as the validating function for the `addRequired` and `addOptional` methods.

Define the function.

```
function a = findArea(shape,dim1,varargin)
 p = inputParser;
 charchk = {'char'};
 numchk = {'numeric'};
 nempty = {'nonempty'};

 addRequired(p,'shape',@(x)validateattributes(x,charchk,nempty));
 addRequired(p,'dim1',@(x)validateattributes(x,numchk,nempty));
 addOptional(p,'dim2',1,@(x)validateattributes(x,numchk,nempty));
 parse(p,shape,dim1,varargin{:});

 switch shape
 case 'circle'
 a = pi * dim1.^2;
 case 'rectangle'
 a = dim1 .* p.Results.dim2;
 end
end
```

Call the function with a nonnumeric third input.

```
myarea = findArea('rectangle',3,'x')
```

Error using findArea (line 10)

Argument 'dim2' failed validation with error:

Expected input to be one of these types:

double, single, uint8, uint16, uint32, uint64, int8, int16, int32, int64



Instead its type was char.

## Validate Arguments of a Function

Check the inputs of a function and include information about the input name and position in generated error.

Define the function.

```
function v = findVolume(shape,ht,wd,ln)
 validateattributes(shape,{'char'},{'nonempty'},mfilename,'Shape',1)
 validateattributes(ht,{'numeric'},{'nonempty'},mfilename,'Height',2)
 validateattributes(wd,{'numeric'},{'nonempty'},mfilename,'Width',3)
 validateattributes(ln,{'numeric'},{'nonempty'},mfilename,'Length',4)
```

Call the function without the shape input string.

```
vol = findVolume(10,7,4)
```

```
Error using findVolume
Expected input number 1, Shape, to be one of these types:
```

```
char
```

Instead its type was double.

```
Error in findVolume (line 2)
validateattributes(shape,{'char'},{'nonempty'},mfilename,'Shape',1)
```

The function name becomes part of the error identifier.

```
MException.last.identifier
```

```
ans =
```

```
MATLAB:findVolume:invalidType
```

## See Also

[validatestring](#) | [is\\*](#) | [isa](#) | [isnumeric](#) | [inputParser](#)

# validatestring

---

**Purpose** Check validity of text string

**Syntax**

```
validStr = validatestring(str,validStrings)
validStr = validatestring(str,validStrings,argIndex)
validStr = validatestring(str,validStrings,funcName)
validStr =
validatestring(str,validStrings,funcName,varName)
validStr =
validatestring(str,validStrings,funcName,varName,argIndex)
```

**Description** `validStr = validatestring(str,validStrings)` checks the validity of text string `str`. If `str` is an unambiguous, case-insensitive match to a string in cell array `validStrings`, the `validatestring` function returns the matching string in `validStr`. Otherwise, MATLAB throws an error and issues a formatted error message.

`validStr = validatestring(str,validStrings,argIndex)` includes the position of the input in your function argument list as part of any generated error messages.

`validStr = validatestring(str,validStrings,funcName)` includes the specified function name in generated error identifiers.

`validStr = validatestring(str,validStrings,funcName,varName)` includes the specified variable name in generated error messages.

`validStr = validatestring(str,validStrings,funcName,varName,argIndex)` includes the specified information in generated error messages or identifiers.

**Input Arguments**

**str**  
String to validate, of type `char`.

**validStrings**  
Cell array of allowed strings.

## funcName

String that specifies the name of the function whose input you are validating. If you specify an empty string, '', the validatestring function ignores the funcname input.

## varName

String that specifies the name of the input variable. If you specify an empty string, '', the validatestring function ignores the varName input.

## argIndex

Positive integer that specifies the position of the input argument.

## Output Arguments

### validStr

String that contains the element of validStrings that is an unambiguous, case-insensitive match to str.

Example – Match 'ball' with . . .	Return Value	Type of Match
ball, barn, bell	ball	Exact match
balloon, barn	balloon	Partial match (leading characters)
ballo, balloo, balloon	ballo (shortest match)	Multiple partial matches where each string is a subset of another
balloon, ballet	Error	Multiple partial matches to unique strings
barn, bell	Error	No match

## Examples

Check whether a string is in a set of valid values.

```
str = 'won';
```

# validatestring

---

```
validStrings = {'wind', 'wonder', 'when'};
```

```
validStr = validatestring(str, validStrings)
```

Because `str` is a partial match to a unique string, this code returns

```
validStr =
 wonder
```

However, if `str` is a partial match to multiple strings, and the strings are not subsets of each other, `validatestring` throws an error and displays a formatted message.

```
str = 'won';
validStrings = {'wonder', 'wondrous', 'wonderful'};
```

```
validStr = validatestring(str, validStrings)
```

The error message is

Expected argument to match one of these strings:

```
wonder, wondrous, wonderful
```

The input, `'won'`, matched more than one valid string.

---

Check inputs to a custom function, and include information about the input name and position in generated errors.

```
function a = findArea(shape, ht, wd, units)
```

```
 a = 0;
 expectedShapes = {'square', 'rectangle', 'triangle'};
 expectedUnits = {'cm', 'm', 'in', 'ft', 'yds'};
```

```
 shapeName = validatestring(shape, expectedShapes, mfilename, 'Shape', 1)
 unitAbbrev = validatestring(units, expectedUnits, mfilename, 'Units', 4)
```

When you call the function with valid input strings,

```
myarea = findArea('rect',10,3,'cm')
```

the function stores the inputs in local variables `shapeName` and `unitAbbrev`:

```
shapeName =
 rectangle
```

```
unitAbbrev =
 cm
```

However, if the inputs are not valid, such as

```
myarea = findArea('circle',10,3,'cm')
```

MATLAB displays

```
Error using findArea
Expected argument 1, Shape, to match one of these strings:
```

```
 square, rectangle, triangle
```

The input, 'circle', did not match any of the valid strings.

The function name is part of the error identifier, so

```
MException.last.identifier
```

```
returns
```

```
MATLAB:findArea:unrecognizedStringChoice
```

## See Also

[validateattributes](#) | [is\\*](#) | [isa](#) | [inputParser](#)

# containers.Map.values

---

**Purpose** Identify values in containers.Map object

**Syntax**  
`valueSet = values(mapObj)`  
`valueSet = values(mapObj, keySet)`

**Description** `valueSet = values(mapObj)` returns all of the values in `mapObj`.  
`valueSet = values(mapObj, keySet)` returns values that correspond to the specified keys.

**Input Arguments**  
**mapObj**  
Object of class `containers.Map`.

**keySet**  
Cell array that specifies keys in `mapObj`.

**Output Arguments**  
**valueSet**  
Cell array containing values from `mapObj`. If you specify `keySet`, the `valueSet` array has the same size and dimensions as `keySet`.

## Examples **Get All Values in a Map**

Create a map, and view all values in the map:

```
myKeys = {'a', 'b', 'c'};
myValues = [1, 2, 3];
mapObj = containers.Map(myKeys, myValues);
```

```
valueSet = values(mapObj)
```

This code returns 1-by-3 cell array `valueSet`:

```
valueSet =
 [1] [2] [3]
```

## Get Selected Values in a Map

View the values corresponding to keys a and c in `mapObj`, created in the previous example:

```
keySet = {'a', 'c'};
valueSet = values(mapObj, keySet)
```

This code returns 1-by-2 cell array `valueSet`:

```
valueSet =
 [1] [3]
```

## See Also

`containers.Map` | `keys` | `isKey`

# vander

---

**Purpose** Vandermonde matrix

**Syntax** `A = vander(v)`

**Description** `A = vander(v)` returns the Vandermonde matrix whose columns are powers of the vector `v`, that is,  $A(i, j) = v(i)^{(n-j)}$ , where  $n = \text{length}(v)$ .

**Examples** `vander(1:.5:3)`

ans =

1.0000	1.0000	1.0000	1.0000	1.0000
5.0625	3.3750	2.2500	1.5000	1.0000
16.0000	8.0000	4.0000	2.0000	1.0000
39.0625	15.6250	6.2500	2.5000	1.0000
81.0000	27.0000	9.0000	3.0000	1.0000

**See Also** `gallery`



**Purpose**

Variance

**Syntax**

```
V = var(X)
V = var(X,1)
V = var(X,w)
V = var(X,w,dim)
```

**Description**

`V = var(X)` returns the variance of `X` for vectors. For matrices, `var(X)` is a row vector containing the variance of each column of `X`. For `N`-dimensional arrays, `var` operates along the first nonsingleton dimension of `X`. The result `V` is an unbiased estimator of the variance of the population from which `X` is drawn, as long as `X` consists of independent, identically distributed samples.

`var` normalizes `V` by  $N - 1$  if  $N > 1$ , where  $N$  is the sample size. This is an unbiased estimator of the variance of the population from which `X` is drawn, as long as `X` consists of independent, identically distributed samples. For  $N = 1$ , `V` is normalized by 1.

`V = var(X,1)` normalizes by  $N$  and produces the second moment of the sample about its mean. `var(X,0)` is equivalent to `var(X)`.

`V = var(X,w)` computes the variance using the weight vector `w`. The length of `w` must equal the length of the dimension over which `var` operates, and its elements must be nonnegative. If `X(i)` is assumed to have variance proportional to  $1/w(i)$ , then  $V * \text{mean}(w)/w(i)$  is an estimate of the variance of `X(i)`. In other words,  $V * \text{mean}(w)$  is an estimate of variance for an observation given weight 1.

`V = var(X,w,dim)` takes the variance along the dimension `dim` of `X`. Pass in 0 for `w` to use the default normalization by  $N - 1$ , or 1 to use  $N$ .

The variance is the square of the standard deviation (STD).

**Examples**

Create a matrix and find the variance along the dimensions.

```
X = [4 -2 1; 9 5 7]
var(X,0,1)
ans =
```

## var

---

```
12.5000 24.5000 18.0000
```

```
var(X,0,2)
```

```
ans =
```

```
9
```

```
4
```

### See Also

[corrcoef](#) | [cov](#) | [mean](#) | [median](#) | [std](#)

**Purpose** Variable-length input argument list

**Syntax** varargin

**Description** varargin is an input variable in a function definition statement that allows the function to accept any number of input arguments. Specify varargin using lowercase characters, and include it as the last input argument after any explicitly declared inputs. When the function executes, varargin is a 1-by- $N$  cell array, where  $N$  is the number of inputs that the function receives after the explicitly declared inputs.

## Examples **Variable Number of Function Inputs**

Define a function in a file named varlist.m that accepts a variable number of inputs and displays the values of each input.

```
function varlist(varargin)
 fprintf('Number of arguments: %d\n',nargin);
 celldisp(varargin)
```

Call varlist with several inputs.

```
varlist(ones(3),'some text',pi)
```

```
Number of arguments: 3
```

```
varargin{1} =
 1 1 1
 1 1 1
 1 1 1
```

```
varargin{2} =
some text
```

```
varargin{3} =
3.1416
```

# varargin

---

## varargin and Declared Inputs

Define a function in a file named `varlist2.m` that expects inputs `X` and `Y`, and accepts a variable number of additional inputs.

```
function varlist2(X,Y,varargin)
 fprintf('Total number of inputs = %d\n',nargin);

 nVarargs = length(varargin);
 fprintf('Inputs in varargin(%d):\n',nVarargs)
 for k = 1:nVarargs
 fprintf(' %d\n', varargin{k})
 end
```

Call `varlist2` with more than two inputs.

```
varlist2(10,20,30,40,50)
```

```
Total number of inputs = 5
Inputs in varargin(3):
 30
 40
 50
```

## See Also

[varargout](#) | [nargin](#) | [nargout](#) | [narginchk](#) | [nargoutchk](#) | [inputname](#)

## Related Examples

- “Support Variable Number of Inputs”

## Concepts

- “Argument Checking in Nested Functions”

**Purpose** Variable-length output argument list

**Syntax** varargout

**Description** varargout is an output variable in a function definition statement that allows the function to return any number of output arguments. Specify varargout using lowercase characters, and include it as the last output argument after any explicitly declared outputs. When the function executes, varargout is a 1-by- $N$  cell array, where  $N$  is the number of outputs requested after the explicitly declared outputs.

## **Examples** Variable Number of Function Outputs

Define a function in a file named `sizeout.m` that returns an output size vector `s` and a variable number of additional scalar values.

```
function [s,varargout] = sizeout(x)
nout = max(nargout,1) - 1;
s = size(x);
for k=1:nout
 varargout{k} = s(k);
end
```

Output `s` contains the dimensions of the input array `x`. Additional outputs correspond to the individual dimensions within `s`.

Call `sizeout` on a three-dimensional array and request three outputs.

```
[s,rows,cols] = sizeout(rand(4,5,2))
```

```
s =
 4 5 2
```

```
rows =
 4
```

```
cols =
 5
```

# varargout

---

## **See Also**

`varargin` | `nargout` | `nargin` | `nargoutchk` | `narginchk` | `inputname`

<b>Purpose</b>	Apply function to table variables
<b>Syntax</b>	$B = \text{varfun}(\text{func}, A)$ $B = \text{varfun}(\text{func}, A, \text{Name}, \text{Value})$
<b>Description</b>	<p><math>B = \text{varfun}(\text{func}, A)</math> applies the function <code>func</code> separately to each variable of the table <code>A</code> and returns the results in the table <code>B</code>.</p> <p>The function <code>func</code> must take one input argument and return arrays with the same number of rows each time it is called. The <math>i</math>th variable in the output table, <math>B\{:, i\}</math>, is equal to <math>\text{func}(A\{:, i\})</math>.</p> <p><math>B = \text{varfun}(\text{func}, A, \text{Name}, \text{Value})</math> applies the function <code>func</code> separately to each variable of the table <code>A</code> with additional options specified by one or more <code>Name, Value</code> pair arguments.</p> <p>For example, you can specify which variables to pass to the function.</p>
<b>Input Arguments</b>	<p><b>func - Function</b> function handle</p> <p>Function, specified as a function handle. You can define the function in a file or as an anonymous function. If <code>func</code> corresponds to more than one function file (that is, if <code>func</code> represents a set of overloaded functions), MATLAB determines which function to call based on the class of the input arguments.</p> <p>Use the <code>'OutputFormat', 'cell'</code> name-value pair argument, if the function <code>func</code> take one input argument and returns arrays with a different numbers of rows each time it is called. Otherwise, <code>func</code> must return arrays with the same number of rows.</p> <p><b>Example:</b> <code>func = @(x) x.^2;</code> computes the square of each element of an input.</p> <p><b>A - Input table</b> table</p> <p>Input table, specified as a table.</p>

## **Name-Value Pair Arguments**

Specify optional comma-separated pairs of `Name`, `Value` arguments. `Name` is the argument name and `Value` is the corresponding value. `Name` must appear inside single quotes ( `' '`). You can specify several name and value pair arguments in any order as `Name1, Value1, ..., NameN, ValueN`.

**Example:** `'InputVariables', 2` uses only the second variable in `A` as an input to `func`.

## **'InputVariables' - Variables of A to pass to func**

positive integer | vector of positive integers | variable name | cell array of variable names | logical vector | ...

Variables of `A` to pass to `func`, specified as the comma-separated pair consisting of `'InputVariables'` and a positive integer, vector of positive integers, variable name, cell array of variable names, or logical vector, or an anonymous function that returns a logical scalar. If you specify `'InputVariables'` as an anonymous function that returns a logical scalar, `varfun` only passes the variables in `A` where the specified function returns 1 (`true`).

## **'GroupingVariables' - One or more variables in A that define groups of rows**

positive integer | vector of positive integers | variable name | cell array of variable names | logical vector

One or more variables in `A` that define groups of rows, specified as the comma-separated pair consisting of `'GroupingVariables'` and a positive integer, vector of positive integers, variable name, cell array of variable names, or logical vector.

A grouping variable can be a numeric vector, logical vector, string (or character array), cell array of strings, or a categorical vector. Rows in `A` that have the same grouping variable values belong to the same group. `varfun` applies `func` to each group of rows within each of the variables of `A`, rather than to each entire variable.



The output, B, has one row for each group when you specify 'OutputFormat', 'uniform' or 'OutputFormat', 'cell'. When you specify 'OutputFormat', 'table', the sizes of the outputs from func determine how many rows of B correspond to each group. When multiple rows of B correspond to a group, varfun appends a unique identifier to the row names.

### 'OutputFormat' - Format of B

'table' (default) | 'uniform' | 'cell'

Format of B, specified as the comma-separated pair consisting of 'OutputFormat' and either the string 'uniform', 'table', or 'cell'.

'table' varfun returns a table with one variable for each variable in A (or each variable specified with 'InputVariables'). For grouped computation, B, also contains the grouping variables.

'table' allows you to use a function that returns values of different sizes or data types for the different variables in A. However, for ungrouped computation, func must return arrays with the same number of rows each time it is called. For grouped computation, func must return values with the same number of rows each time it is called for a given group.

This is the default output format.

'uniform' varfun concatenates the values into a vector. func must return a scalar with the same data type each time it is called.

'cell' varfun returns B as a cell array. 'cell' allows you to use a function that returns values of different sizes or data types.

### 'ErrorHandler' - Function to call if func fails

function handle

# varfun

---

Function to call if `func` fails, specified as the comma-separated pair consisting of 'ErrorHandler' and a function handle. Define this function so that it rethrows the error or returns valid outputs for function `func`.

MATLAB calls the specified error-handling function with two input arguments:

- A structure with these fields:

<code>identifier</code>	Error identifier.
<code>message</code>	Error message text.
<code>index</code>	Index of the variable for which the error occurred.
<code>name</code>	Name of the variable for which the error occurred.

- The set of input arguments to function `func` at the time of the error.

For example,

```
function [A, B] = errorFunc(S, varargin)
warning(S.identifier, S.message);
A = NaN; B = NaN;
```

## Output Arguments

### **B** - Output table

table

Output table, returned as a table. The table can store metadata such as descriptions, variable units, variable names, and row names. For more information, see [Table Properties](#).

## Examples

### Apply Element-wise Function

Define and apply an element-wise function to the variables of a table to square all the elements.

Define a table containing numeric variables.

```
A = table([0.71;-2.05;-0.35;-0.82;1.57],[0.23;0.12;-0.18;0.23;0.41])
```

```
A =
```

Var1	Var2
0.71	0.23
-2.05	0.12
-0.35	-0.18
-0.82	0.23
1.57	0.41

Define the anonymous function to find the square of an input.

```
func = @(x) x.^2;
```

Apply the function to all the variables of table A.

```
B = varfun(func,A)
```

```
B =
```

Fun_Var1	Fun_Var2
0.5041	0.0529
4.2025	0.0144
0.1225	0.0324
0.6724	0.0529
2.4649	0.1681

The variables of B have names based on the function and the variable names from A.

### **Apply Function that Returns Scalar From Vector**

Compute the mean of each variable in a 5-by-2 table.

# varfun

---

Define a table containing numeric variables.

```
A = table([0.71;-2.05;-0.35;-0.82;1.57],[0.23;0.12;-0.18;0.23;0.41])
```

A =

Var1	Var2
0.71	0.23
-2.05	0.12
-0.35	-0.18
-0.82	0.23
1.57	0.41

Define the anonymous function to find the mean of an input.

```
func = @mean;
```

func uses an existing MATLAB function to define the operation.

Apply the function to all the variables of table A.

```
B = varfun(func,A)
```

B =

mean_Var1	mean_Var2
-0.188	0.162

B is a table containing the average value from each variable.

To return a numeric vector instead of a table, you can use `B = varfun(func,A,'OutputFormat','uniform')`.

## Apply Function to Groups Within Variables

Compute the group-wise means of variables in a table, A, and return them as rows in a table, B.

Create a table where one variable defines groups.

```
A = table({'test2';'test1';'test2';'test3';'test1'},...
 [0.71;-2.05;-0.35;-0.82;1.57],[0.23;0.12;-0.18;0.23;0.41])
```

A =

Var1	Var2	Var3
'test2'	0.71	0.23
'test1'	-2.05	0.12
'test2'	-0.35	-0.18
'test3'	-0.82	0.23
'test1'	1.57	0.41

Define the anonymous function to find the mean of an input.

```
func = @mean;
```

func uses an existing MATLAB function to define the operation.

Apply the function to each group of data defined by Var1.

```
B = varfun(func,A,'GroupingVariables','Var1')
```

B =

	Var1	GroupCount	mean_Var2	mean_Var3
test1	'test1'	2	-0.24	0.265
test2	'test2'	2	0.18	0.025
test3	'test3'	1	-0.82	0.23

B contains row names based on the grouping variables and a variable called GroupCount to indicate the number of entries from table A in that group.

# varfun

---

## See Also

[rowfun](#) | [cellfun](#) | [structfun](#) | [arrayfun](#)

## Concepts

- “Anonymous Functions”

**Purpose** Vectorize expression

**Syntax** `vectorize(s)`  
`vectorize(f)`

**Description** `vectorize(s)` where `s` is a string expression, inserts a `.` before any `^`, `*` or `/` in `s`. The result is a character string.

---

**Note** `vectorize` will not accept inline function objects (`f`) in a future release.

---

`vectorize(f)` where `f` is an inline function object, vectorizes the formula for `f`. The result is the vectorized version of the function.

**See Also** `inline` | `cd` | `dbtype` | `delete` | `dir` | `path` | `what` | `who`

**Purpose** Version information for MathWorks products

**Syntax**

```
ver
ver product

product_info = ver(product)
```

**Description** `ver` displays:

- A header containing the current MATLAB product family version number, license number, operating system, and version of Java software for the MATLAB product.
- The version numbers for MATLAB and all other installed MathWorks products.

`ver product` displays, in addition to the header information:

- The current version number for `product`, where `product` is the name of the folder that contains the `Contents.m` file for the product you are inquiring about.

`product_info = ver(product)` returns product information to the structure array, `product_info`.

## Input Arguments

**product - product-specific information**  
string

The product or toolbox for which you want to view version information, specified as a string.

To determine the string to use, run the following code, substituting the name of a product function for *toolboxfcn*:

```
n = 'toolboxfcn';
pat = '(?<=^[\\/]toolbox[\\/])[^\\/]+';
regexp(which(n), pat, 'match', 'once')
```



## Output Arguments

### **product\_info - product name, version, release, and date**

structure array

Product name, version, release, and date, returned as a structure array with these fields: Name, Version, Release, and Date. If a license is a trial version, the value in the Version field is preceded by the letter T

## Examples

### **Version for All Installed Products**

Display version information for all installed products. The output shown here is representative. Your results may differ.

```
ver
```

```

MATLAB Version: 8.2.0.29 (R2013b)
MATLAB License Number: 234567
Operating System: Microsoft Windows 7 Version 6.1 (Build 7601: Service
Java Version: Java 1.7.0_11-b21 with Oracle Corporation Java HotSpot (T

```

```
MATLAB Version 8.2
Simulink Version 8.2
Control System Toolbox Version 9.6
```

### **Version for a Particular Product**

Display version information for MATLAB and the Control System Toolbox product. The output shown here is representative. Your results may differ.

1. Determine the product name for Control System Toolbox by setting `n` to the name of a function unique to Control System Toolbox, such as `dss`:

```
n = 'dss';
pat = '(?<=^.+[\\\/]toolbox[\\\/])[^\\\/]+';
regexp(which(n), pat, 'match', 'once')
```

```
ans=
control
```

2. Specify the value returned in the previous step as an argument to `ver`:

```
ver control
```

```

MATLAB Version: 8.2.0.29 (R2013b)
MATLAB License Number: 234567
Operating System: Microsoft Windows 7 Version 6.1 (Build 7601: Service Pa
Java Version: Java 1.7.0_11-b21 with Oracle Corporation Java HotSpot(TM)

Control System Toolbox Version 9.6
```

### **Structure Containing Version for the MATLAB family of products**

Create a structure containing version information, and then display the structure values. The output shown here is representative. Your results may differ.

```
v = ver;
for k = 1:length(v)
 fprintf('%s\n', v(k).Name);
 fprintf(' Version: %s\n', v(k).Version);
end
```

```
MATLAB
 Version: 8.2
```

```
MATLAB Builder JA
 Version: 2.3
```

```
MATLAB Builder NE
 Version: 4.2
```

```
MATLAB Compiler
 Version: 5.0
```

```
My Custom Toolbox
```

Version: 1.0

## Structure Containing Version for a Particular Product

Create a structure containing version information for just the Symbolic Math Toolbox™ product. The output shown here is representative. Your results may differ.

1. Determine the product name for Symbolic Math Toolbox by setting `n` to the name of a function unique to Symbolic Math Toolbox, such as `sym`:

```
n = 'sym';
pat = '(?<=^[\\/]toolbox[\\/])(^[\\/]+';
regexpi(which(n), pat, 'match', 'once')
```

```
ans =
```

```
symbolic
```

2. Specify the value returned in the previous step as an argument to `ver`:

```
v = ver('symbolic')
```

```
v =
```

```
 Name: 'Symbolic Math Toolbox'
 Version: '5.11'
 Release: '(R2013b)'
 Date: '19-May-2013'
```

## See Also

[computer](#) | [help](#) | [license](#) | [verlessthan](#) | [version](#) |

## Concepts

- “Information About your Installation”
- “Create Help Summary Files (Contents.m)”

# verctrl

---

**Purpose** Source control actions (Windows platforms)

**Syntax**

```
verctrl('action',{filename1,'filename2',...},0)
result=verctrl('action',{filename1,'filename2',...},0)
verctrl('action','filename',0)
result=verctrl('isdiff','filename',0)
list = verctrl('all_systems')
```

**Description** verctrl('action',{filename1,'filename2',...},0) performs the source control operation specified by 'action' for a single file or multiple files. Enter one file as a string; specify multiple files using a cell array of strings. Use the full paths for each file name and include the extensions. Specify 0 as the last argument. Complete the resulting dialog box to execute the operation. Available values for 'action' are as follows:

<b>action Argument</b>	<b>Purpose</b>
'add'	Adds files to the source control system. Files can be open in the Editor or closed when added.
'checkin'	Checks files into the source control system, storing the changes and creating a new version.
'checkout'	Retrieves files for editing.
'get'	Retrieves files for viewing and compiling, but not editing. When you open the files, they are labeled as read-only.
'history'	Displays the history of files.
'remove'	Removes files from the source control system. It does not delete the files from disk, but only from the source control system.

<b>action Argument</b>	<b>Purpose</b>
'runsc'	Starts the source control system. The file name can be an empty string.
'uncheckout'	Cancels a previous checkout operation and restores the contents of the selected files to the precheckout version. All changes made to the files since the checkout are lost.

`result=verctrl('action',{'filename1','filename2',...},0)` performs the source control operation specified by *action* on a single file or multiple files. The action can be any one of: 'add', 'checkin', 'checkout', 'get', 'history', or 'undocheckout'. `result` is a logical 1 (true) when you complete the operation by clicking **OK** in the resulting dialog box, and is a logical 0 (false) when you abort the operation by clicking **Cancel** in the resulting dialog box.

`verctrl('action','filename',0)` performs the source control operation specified by *action* for a single file. Use the absolute path for *filename*. Specify 0 as the last argument. Complete any resulting dialog boxes to execute the operation. Available values for *action* are as follows:

<b>action Argument</b>	<b>Purpose</b>
'showdiff'	Displays the differences between a file and the latest checked in version of the file in the source control system.
'properties'	Displays the properties of a file.

`result=verctrl('isdiff','filename',0)` compares `filename` with the latest checked in version of the file in the source control system. `result` is a logical 1 (true) when the files are different, and is a logical 0

(false) when the files are identical. Use the full path for 'filename'. Specify 0 as the last argument.

`list = verctrl('all_systems')` displays in the Command Window a list of all source control systems installed on your computer.

## Examples

### Check In a File

Check in D:\file1.ext to the source control system:

```
result = verctrl('checkin','D:\file1.ext', 0)
```

This opens the Check in file(s) dialog box. Click **OK** to complete the check in. MATLAB displays

```
result = 1
```

indicating the checkin was successful.

### Add Files to the Source Control System

Add D:\file1.ext and D:\file2.ext to the source control system.

```
verctrl('add',{'D:\file1.ext','D:\file2.ext'}, 0)
```

This opens the Add to source control dialog box. Click **OK** to complete the operation.

### Display the Properties of a File

Display the properties of D:\file1.ext.

```
verctrl('properties','D:\file1.ext', 0)
```

This opens the source control properties dialog box for your source control system. The function is complete when you close the properties dialog box.

### Show Differences for a File

To show the differences between the version of file1.ext that you just edited and saved, with the last version in source control, run

```
verctrl('showdiff','D:\file1.ext',0)
```

MATLAB displays differences dialog boxes and results specific to your source control system. After checking in the file, if you run this statement again, MATLAB displays

```
??? The file is identical to latest version under source control.
```

### List All Installed Source Control Systems

To view all of the source control systems installed on your computer, type

```
list = verctrl ('all_systems')
```

MATLAB displays all the source control systems currently installed on your computer. For example:

```
list =
'Microsoft Visual SourceSafe'
'ComponentSoftware RCS'
```

### See Also

[checkin](#) | [checkout](#) | [undocheckout](#) | [cmopts](#)

### How To

- “Source Control Interface on Microsoft Windows”

# verLessThan

---

**Purpose** Compare toolbox version to specified version string

**Syntax** `verLessThan(toolbox, version)`

**Description** `verLessThan(toolbox, version)` returns logical 1 (true) if the version of the toolbox specified by the string `toolbox` is older than the version specified by the string `version`, and logical 0 (false) otherwise. Use this function when you want to write code that can run across multiple versions of the MATLAB software, when there are differences in the behavior of the code in the different versions.

The `toolbox` argument is a string enclosed within single quotation marks that contains the name of a MATLAB toolbox folder. The `version` argument is a string enclosed within single quotation marks that contains the version to compare against. This argument must be in the form `major[.minor[.revision]]`, such as 7, 7.1, or 7.0.1. If `toolbox` does not exist, MATLAB generates an error.

To specify `toolbox`, find the folder that holds the `Contents.m` file for the toolbox and use that folder name. To see a list of all toolbox folder names, enter the following statement in the MATLAB Command Window:

```
dir([matlabroot '/toolbox'])
```

## Examples

These examples illustrate usage of the `verLessThan` function.

### Example 1 – Checking For the Minimum Required Version

```
if verLessThan('simulink', '4.0')
 error('Simulink 4.0 or higher is required.');
```

```
end
```

### Example 2 – Choosing Which Code to Run

```
if verLessThan('matlab', '7.0.1')
% -- Put code to run under MATLAB 7.0.0 and earlier here --
else
% -- Put code to run under MATLAB 7.0.1 and later here --
```



```
end
```

### Example 3 – Looking Up the Folder Name

Find the name of the Data Acquisition Toolbox folder:

```
dir([matlabroot '/toolbox/d*'])
```

```
 daq database des distcomp dotnetbuilder
 dastudio datafeed dials dml dspblks
```

Use the toolbox folder name, daq, to compare the Data Acquisition Toolbox software version that MATLAB is currently running against version number 3:

```
verLessThan('daq', '3')
```

```
ans =
```

```
 1
```

### See Also

[ver](#) | [version](#) | [license](#) | [ispc](#) | [isunix](#) | [ismac](#) | [dir](#)

# version

---

**Purpose** Version number for MATLAB and libraries

**Syntax**

```
version
version -date
version -description
version -release
version -java
v = version('-versionOption')
[v d] = version
```

**Description**

`version` returns in `ans` the version and release number for the MATLAB software currently running.

`version -date` returns in `ans` the release date for the MATLAB software.

`version -description` returns in `ans` a description of the version. Usually, the description is for special versions, such as beta versions.

`version -release` returns in `ans` the release number for the MATLAB software currently running.

`version -java` returns in `ans` the version of the Oracle JVM software that MATLAB is using.

`v = version('-versionOption')`, where *versionOption* is one of the above option strings, is an alternate form of the syntax.

`[v d] = version` returns the version and release number in string `v` and the release date in string `d`. No input arguments are allowed in this syntax.

**Examples**      **Display MATLAB Version**

```
version

ans =

8.2.0.29 (R2013b)
```

## Display MATLAB Release

Display the release, prefaced by a descriptor.

```
['Release R' version('-release')]
```

```
ans =
```

```
Release R2013b
```

## Get Release Version and Date as Separate Strings

```
[v d] = version
```

```
v =
```

```
8.2.0.29 (R2013b)
```

```
d =
```

```
May 19, 2013
```

## Display Java Version

```
version -java
```

```
ans =
```

```
Java 1.7.0_11-b21 with Oracle Corporation Java HotSpot(TM) 64-Bit Ser
```

## See Also

```
computer | ver | verlessthan
```

## How To

- “Check for Software Updates”

# vertcat

---

**Purpose** Concatenate arrays vertically

**Syntax** `C = vertcat(A1,...,AN)`

**Description** `C = vertcat(A1,...,AN)` vertically concatenates arrays `A1,...,AN`. All arrays in the argument list must have the same number of columns.

- If the inputs are multidimensional arrays, `vertcat` concatenates N-dimensional arrays along the first dimension. The remaining dimensions must match.
- If the inputs are tables, `vertcat` concatenates by matching variable names. Variable names for all tables must be identical, except for order. Row names, when present, must be unique across tables.

`vertcat` fills in default row names when some of the inputs have names and some do not. `vertcat` assigns values for each table property (except for `RowNames`) using the first nonempty value for the corresponding property in the tables `A1,...,AN`.

`vertcat` also concatenates character strings. Each string being concatenated must have the same number of characters.

MATLAB calls `C = vertcat(A1, A2, ...)` for the syntax `C = [A1; A2; ...]` when any of the inputs are an object.

**Tips** You can concatenate categorical arrays with cell arrays of strings. For more information, see “Combine Categorical Arrays”.

If all the input arrays are ordinal categorical arrays, they must have the same sets of categories including their order. For more information, see “Ordinal Categorical Arrays”.

For information on combining unlike integer types, integers with nonintegers, cell arrays with non-cell arrays, or empty matrices with other elements, see “Valid Combinations of Unlike Classes”.

**Examples** **Vertically Concatenate Two Matrices**

Create a 5-by-3 matrix, `A`.

```
A = magic(5);
A(:, 4:5) = []
```

```
A =
```

```
 17 24 1
 23 5 7
 4 6 13
 10 12 19
 11 18 25
```

Create a 3-by-3 matrix, B.

```
B = magic(3)*100
```

```
B =
```

```
 800 100 600
 300 500 700
 400 900 200
```

Vertically concatenate A and B.

```
C = vertcat(A,B)
```

```
C =
```

```
 17 24 1
 23 5 7
 4 6 13
 10 12 19
 11 18 25
 800 100 600
 300 500 700
 400 900 200
```

### Vertically Concatenate Two Tables

Create a table, A, with three rows and five variables.

# vertcat

```
A = table([5;6;5],['M'; 'M'; 'M'],[45;41;40],[45;32;34],{'NY'; 'CA'; 'MA'},...
 'VariableNames',{'Age' 'Gender' 'Height' 'Weight' 'Birthplace'},...
 'RowNames',{'Thomas' 'Gordon' 'Percy'})
```

A =

	Age	Gender	Height	Weight	Birthplace
Thomas	5	M	45	45	'NY'
Gordon	6	M	41	32	'CA'
Percy	5	M	40	34	'MA'

Create a table, B, with the same variables as A except for order.

```
B = table(['F'; 'M'; 'F'],[6;6;5],{'AZ'; 'NH'; 'CO'},[31;42;33],[39;43;40],...
 'VariableNames',{'Gender' 'Age' 'Birthplace' 'Weight' 'Height'})
```

B =

	Gender	Age	Birthplace	Weight	Height
F		6	'AZ'	31	39
M		6	'NH'	42	43
F		5	'CO'	33	40

Vertically concatenate tables A and B.

```
C = vertcat(A,B)
```

C =

	Age	Gender	Height	Weight	Birthplace
Thomas	5	M	45	45	'NY'
Gordon	6	M	41	32	'CA'
Percy	5	M	40	34	'MA'
Row4	6	F	39	31	'AZ'
Row5	6	M	43	42	'NH'

```
Row6 5 F 40 33 'C0'
```

The variables of **C** are in the same order as the variables of **A** and default row names are used for the rows from **B**.

**See Also**

`horzcat` | `cat`

**How To**

- “Redefining Concatenation for Your Class”

# vertcat (tscollection)

---

**Purpose** Vertical concatenation for tscollection objects

**Syntax** `tsc = vertcat(tsc1,tsc2,...)`

**Description** `tsc = vertcat(tsc1,tsc2,...)` performs  
`tsc = [tsc1;tsc2;...]`

This operation appends tscollection objects. The time vectors must not overlap. The last time in tsc1 must be earlier than the first time in tsc2. All tscollection objects to be concatenated must have the same timeseries members.

**See Also** `horzcat (tscollection) | tscollection`



**Purpose** (Will be removed) Return simplices attached to specified vertices

---

**Note** `vertexAttachments(TriRep)` will be removed in a future release. Use `vertexAttachments(triangulation)` instead.

---

`TriRep` will be removed in a future release. Use `triangulation` instead.

---

**Syntax** `SI = vertexAttachments(TR, VI)`

**Description** `SI = vertexAttachments(TR, VI)` returns the vertex-to-simplex information for the specified vertices `VI`. For 2-D triangulations in MATLAB, the triangles `SI` are arranged in counter-clockwise order around the attached vertex `VI`.

**Input Arguments**

<code>TR</code>	Triangulation representation
<code>VI</code>	<code>VI</code> is a column vector of indices into the array of points representing the vertex coordinates, <code>TR.X</code> . The simplices associated with vertex <code>i</code> are the <code>i</code> 'th entry in the cell array. If <code>VI</code> is not specified the vertex-simplex information for the entire triangulation is returned.

**Output Arguments**

<code>SI</code>	Cell array of indices of the simplices attached to a vertex. A cell array is used to store the information because the number of simplices associated with each vertex can vary. The simplices associated with vertex <code>i</code> are in the <code>i</code> 'th entry in the cell array <code>SI</code> .
-----------------	--------------------------------------------------------------------------------------------------------------------------------------------------------------------------------------------------------------------------------------------------------------------------------------------------------------

**Definitions** A simplex is a triangle/tetrahedron or higher dimensional equivalent.

# TriRep.vertexAttachments

---

## Examples

### Example 1

Load a 2-D triangulation and use TriRep to compute the vertex-to-triangle relations.

```
load trimesh2d
trep = TriRep(tri, x, y);
```

Find the indices of the tetrahedra attached to the first vertex:

```
Tv = vertexAttachments(trep, 1)
Tv{:}
```

### Example 2

Perform a direct query of a 2-D triangulation created using DelaunayTri.

```
x = rand(20,1);
y = rand(20,1);
dt = DelaunayTri(x,y);
```

Find the triangles attached to vertex 5:

```
t = vertexAttachments(dt,5);
```

Plot the triangulation:

```
triplot(dt);
hold on;
```

Plot the triangles attached to vertex 5 (in red):

```
triplot(dt(t{:},:),x,y,'Color','r');
hold off;
```

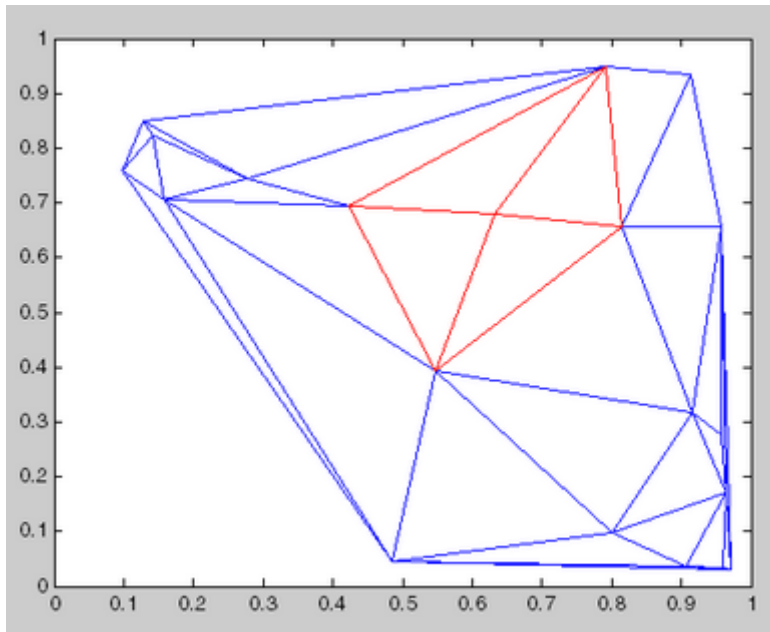

**See Also** [delaunayTriangulation](#) | [triangulation](#)

# VideoReader

---

**Purpose** Read video files

**Description** Use the `VideoReader` function with the `read` method to read video data from a file into the MATLAB workspace.

The file formats that `VideoReader` supports vary by platform, as follows (with no restrictions on file extensions):

All Platforms	AVI, including uncompressed, indexed, grayscale, and Motion JPEG-encoded video (.avi) Motion JPEG 2000 (.mj2)
All Windows	MPEG-1 (.mpg) Windows Media Video (.wmv, .asf, .asx) Any format supported by Microsoft DirectShow®
Windows 7 or later	MPEG-4, including H.264 encoded video (.mp4, .m4v) Apple QuickTime Movie (.mov) Any format supported by Microsoft Media Foundation
Macintosh	Most formats supported by QuickTime Player, including: MPEG-1 (.mpg) MPEG-4, including H.264 encoded video (.mp4, .m4v) Apple QuickTime Movie (.mov) 3GPP 3GPP2 AVCHD DV
Linux	Any format supported by your installed plug-ins for GStreamer 0.10 or above, as listed on <a href="http://gstreamer.freedesktop.org/documentation/plugins.html">http://gstreamer.freedesktop.org/documentation/plugins.html</a> , including Ogg Theora (.ogg).

**Construction** `obj = VideoReader(filename)` constructs `obj` to read video data from the file named `filename`. If it cannot construct the object for any reason, `VideoReader` generates an error.

`obj = VideoReader(filename,Name,Value)` constructs the object with additional options specified by one or more **Name,Value** pair arguments. **Name** is 'Tag' or 'UserData' and **Value** is the corresponding value. You can specify two name and value pair arguments in any order as `Name1,Value1,Name2,Value2`.

## Input Arguments

### filename

String in single quotation marks that specifies the video file to read. The `VideoReader` constructor searches for the file on the MATLAB path.

### Name-Value Pair Arguments

Optional comma-separated pairs of **Name,Value** arguments, where **Name** is 'Tag' or 'UserData' and **Value** is the corresponding value. You can specify two name and value pair arguments in any order as `Name1,Value1,Name2,Value2`.

### Tag

String that identifies the object.

**Default:** ''

### UserData

Generic field for data of any class that you want to add to the object.

**Default:** []

## Properties

All properties are read-only except `Tag` and `UserData`.

### BitsPerPixel

Bits per pixel of the video data.

# VideoReader

---

## **Duration**

Total length of the file in seconds.

## **FrameRate**

Frame rate of the video in frames per second.

## **Height**

Height of the video frame in pixels.

## **Name**

Name of the file associated with the object.

## **NumberOfFrames**

Total number of frames in the video stream.

Some files store video at a variable frame rate, including many Windows Media Video files. For these files, `VideoReader` cannot determine the number of frames until you read the last frame. When you construct the object, `VideoReader` returns a warning and does not set the `NumberOfFrames` property.

To count the number of frames in a variable frame rate file, use the `read` method to read the last frame of the file. For example:

```
vidObj = VideoReader('varFrameRateFile.wmv');
lastFrame = read(vidObj, inf);
numFrames = vidObj.NumberOfFrames;
```

For more information, see “Read Variable Frame Rate Video” in the MATLAB Data Import and Export documentation..

## **Path**

String containing the full path to the file associated with the reader.

## **Tag**

String that identifies the object.

**Default:** ''

## Type

Class name of the object: 'VideoReader'.

## UserData

Generic field for data of any class that you want to add to the object.

**Default:** []

## VideoFormat

String indicating the MATLAB representation of the video format.

Video Format	Value of VideoFormat
AVI or MPEG-4 files with RGB24 video	'RGB24'
AVI files with indexed video	'Indexed'
AVI files with grayscale video	'Grayscale'

For Motion JPEG 2000 files, VideoFormat is one of the following.

Format of Image Data	Value of VideoFormat
Single-band uint8	'Mono8'
Single-band int8	'Mono8 Signed'
Single-band uint16	'Mono16'
Single-band int16	'Mono16 Signed'
Three-banded uint8	'RGB24'
Three-banded int8	'RGB24 Signed'
Three-banded uint16	'RGB48'
Three-banded int16	'RGB48 Signed'

# VideoReader

---

## Width

Width of the video frame in pixels.

## Methods

<code>get</code>	Query property values for video reader object
<code>getFileFormats</code>	File formats that <code>VideoReader</code> supports
<code>read</code>	Read video frame data from file
<code>set</code>	Set property values for video reader object

## Copy Semantics

Handle. To learn how handle classes affect copy operations, see Copying Objects in the MATLAB documentation.

## Examples

### Construct VideoReader Object

Construct a `VideoReader` object for the example movie file `xylophone.mp4` and view its properties.

```
xyloObj = VideoReader('xylophone.mp4','Tag','My reader object');
get(xyloObj)
```

General Settings:

```
Duration = 4.7000
Name = xylophone.mp4
Path = matlabroot\toolbox\matlab\audiovideo
Tag = My reader object
Type = VideoReader
UserData = []
```

Video Settings:

```
BitsPerPixel = 24
FrameRate = 30
Height = 240
```



```
NumberOfFrames = 141
VideoFormat = RGB24
Width = 320
```

## Read and Play Back Movie File

Read and play back the movie file `xylophone.mp4`.

```
xyloObj = VideoReader('xylophone.mp4');
```

```
nFrames = xyloObj.NumberOfFrames;
vidHeight = xyloObj.Height;
vidWidth = xyloObj.Width;
```

Preallocate the movie structure.

```
mov(1:nFrames) = ...
 struct('cdata',zeros(vidHeight,vidWidth, 3,'uint8'),...
 'colormap',[]);
```

Read one frame at a time.

```
for k = 1 : nFrames
 mov(k).cdata = read(xyloObj,k);
end
```

Size a figure based on the video's width and height.

```
hf = figure;
set(hf, 'position', [150 150 vidWidth vidHeight])
```

Play back the movie once at the video's frame rate.

```
movie(hf, mov, 1, xyloObj.FrameRate);
```

## See Also

[mmfileinfo](#) | [VideoWriter](#)

## How To

- “Read Video Files”

# VideoWriter

---

**Purpose** Write video files

**Description** Use the `VideoWriter` object with the `open`, `writeVideo`, and `close` methods to create video files from figures, still images, or MATLAB movies. `VideoWriter` can create uncompressed AVI and Motion JPEG 2000 compressed AVI files on all platforms, and MPEG-4 files on Windows 7 or later and Mac OS X 10.7 and higher. `VideoWriter` supports files larger than 2 GB, which is the limit for `avifile`.

To set video properties, `VideoWriter` includes predefined *profiles* such as 'Uncompressed AVI' or 'MPEG-4'.

**Construction** `writerObj = VideoWriter(filename)` constructs a `VideoWriter` object to write video data to an AVI file with Motion JPEG compression.

`writerObj = VideoWriter(filename,profile)` applies a set of properties tailored to a specific file format (such as 'MPEG-4' or 'Uncompressed AVI') to a `VideoWriter` object.

## Input Arguments

### **filename**

String enclosed in single quotation marks that specifies the name of the file to create.

`VideoWriter` supports these file extensions:

<code>.avi</code>	AVI file
<code>.mj2</code>	Motion JPEG 2000 file
<code>.mp4</code> or <code>.m4v</code>	MPEG-4 file (systems with Windows 7 or later, or Mac OS X 10.7 and later)

If you do not specify a valid file extension, `VideoWriter` appends the extension `.avi`, `.mj2` or `.mp4`, depending on the `profile`. If you do not specify a value for `profile`, then `VideoWriter` creates a Motion JPEG compressed AVI file with the extension `.avi`.

## profile

String enclosed in single quotation marks that describes the type of file to create. Specifying a profile sets default values for video properties such as `VideoCompressionMethod`. Possible values:

'Archival'	Motion JPEG 2000 file with lossless compression
'Motion JPEG AVI'	Compressed AVI file using Motion JPEG codec
'Motion JPEG 2000'	Compressed Motion JPEG 2000 file
'MPEG-4'	Compressed MPEG-4 file with H.264 encoding (systems with Windows 7 or later, or Mac OS X 10.7 and later)
'Uncompressed AVI'	Uncompressed AVI file with RGB24 video
'Indexed AVI'	Uncompressed AVI file with indexed video
'Grayscale AVI'	Uncompressed AVI file with grayscale video

**Default:** 'Motion JPEG AVI'

## Properties

### ColorChannels

Number of color channels in each output video frame. (Read-only)

AVI and MPEG-4 files with RGB24 data have three color channels. Indexed and Grayscale AVI files have one color channel. The number of channels for Motion JPEG 2000 files depends on the input data to the `writeVideo` method: one for monochrome image data, three for color data.

### Colormap

P-by-3 numeric matrix that contains color information about the video file. The colormap can have a maximum of 256 entries of type `uint8` or `double`. The entries of the colormap must be integers. Each row of `Colormap` specifies the red, green, and blue components of a single color. The colormap can be set explicitly before the call to `open`, or using the `colormap` field of a movie frame structure at the time of writing the first frame.

Only applies to objects associated with Indexed AVI files.

After you call `open`, you cannot change the `Colormap` value.

**Default:** none

## **CompressionRatio**

Number greater than 1 that specifies the target ratio between the number of bytes in the input image and the number of bytes in the compressed image. The data is compressed as much as possible, up to the specified target.

Only available for objects associated with Motion JPEG 2000 files. After you call `open`, you cannot change the `CompressionRatio` value. If you previously set `LosslessCompression` to `true`, setting `CompressionRatio` generates an error.

**Default:** 10

## **Duration**

Scalar value specifying the duration of the file in seconds.  
(Read-only)

## **FileFormat**

String specifying the type of file to write: `'avi'`, `'mp4'`, or `'mj2'`.  
(Read-only)

## **Filename**

String specifying the name of the file. (Read-only)

## **FrameCount**

Number of frames written to the video file. (Read-only)

## **FrameRate**

Rate of playback for the video in frames per second. After you call `open`, you cannot change the `FrameRate` value.

**Default:** 30

## **Height**

Height of each video frame in pixels. The `writeVideo` method sets values for `Height` and `Width` based on the dimensions of the first frame. (Read-only)

MPEG-4 files require frame dimensions that are divisible by two. If the input frame height for an MPEG-4 file is not an even number, `VideoWriter` pads the frame with a row of black pixels at the bottom.

## **LosslessCompression**

Boolean value (logical `true` or `false`) only available for objects associated with Motion JPEG 2000 files. If `true`:

- The `writeVideo` method uses reversible mode so that the decompressed data is identical to the input data.
- `VideoWriter` ignores any specified value for `CompressionRatio`.

After you call `open`, you cannot change the `LosslessCompression` value.

**Default:** `false` for the 'Motion JPEG 2000' profile, `true` for the 'Archival' profile

## **MJ2BitDepth**

# VideoWriter

---

Number of least significant bits in the input image data, from 1 to 16.

Only available for objects associated with Motion JPEG 2000 files. If you do not specify a value before calling the `open` method, VideoWriter sets the bit depth based on the input data type. For example, if the input data to `writeVideo` is an array of `uint8` or `int8` values, `MJ2BitDepth` is 8.

## **Path**

String specifying the fully qualified path. (Read-only)

## **Quality**

Integer from 0 through 100. Higher quality numbers result in higher video quality and larger file sizes. Lower quality numbers result in lower video quality and smaller file sizes.

Only available for objects associated with the MPEG-4 or Motion JPEG AVI profile. After you call `open`, you cannot change the Quality value.

**Default:** 75

## **VideoBitsPerPixel**

Number of bits per pixel in each output video frame. (Read-only)

AVI and MPEG-4 files have 24 bits per pixel (8 bits for each of three color bands).

For Motion JPEG 2000 files, the number of bits per pixel depends on the value of `MJ2BitDepth` and the number of bands of image data. For example, if the input data to `writeVideo` is a three-dimensional array of `uint16` or `int16` values, the default value of `MJ2BitDepth` is 16, and `VideoBitsPerPixel` is 48 (three times the bit depth).

## **VideoCompressionMethod**

String indicating the type of video compression: 'None', 'H.264', 'Motion JPEG', or 'Motion JPEG 2000'. (Read-only)

## VideoFormat

String indicating the MATLAB representation of the video format. (Read-only)

Video Format	Value of VideoFormat
AVI or MPEG-4 files with RGB24 video	'RGB24'
AVI files with indexed video	'Indexed'
AVI files with grayscale video	'Grayscale'

For Motion JPEG 2000 files, VideoFormat depends on the value of MJ2BitDepth and the format of the input image data to the writeVideo method. For example, if you do not specify the MJ2BitDepth property, VideoWriter sets the format as shown in this table.

Format of Image Data	Value of VideoFormat
Single-band uint8	'Mono8'
Single-band int8	'Mono8 Signed'
Single-band uint16	'Mono16'
Single-band int16	'Mono16 Signed'
Three-banded uint8	'RGB24'
Three-banded int8	'RGB24 Signed'
Three-banded uint16	'RGB48'
Three-banded int16	'RGB48 Signed'

## Width

# VideoWriter

---

Width of each video frame in pixels. The `writeVideo` method sets values for `Height` and `Width` based on the dimensions of the first frame. (Read-only)

MPEG-4 files require frame dimensions that are divisible by two. If the input frame width for an MPEG-4 file is not an even number, `VideoWriter` pads the frame with a column of black pixels along the right side.

## Methods

<code>close</code>	Close file after writing video data
<code>getProfiles</code>	List profiles and file formats supported by <code>VideoWriter</code>
<code>open</code>	Open file for writing video data
<code>writeVideo</code>	Write video data to file

## Copy Semantics

Handle. To learn how handle classes affect copy operations, see [Copying Objects in the MATLAB documentation](#).

## Examples

### View and Set Object Properties

Construct a `VideoWriter` object and view its properties.

```
writerObj = VideoWriter('newfile.avi')
```

Set the frame rate to 60 frames per second, using the `FrameRate` property.

```
writerObj.FrameRate = 60;
```

### AVI File from Animation

Write a sequence of frames to a compressed AVI file, `peaks.avi`.

Prepare the new file.

```
writerObj = VideoWriter('peaks.avi');
```



```
open(writerObj);
```

Generate initial data and set axes and figure properties.

```
Z = peaks; surf(Z);
axis tight
set(gca, 'nextplot', 'replacechildren');
set(gcf, 'Renderer', 'zbuffer');
```

Setting the `Renderer` property to `zbuffer` or `Painters` works around limitations of `getframe` with the OpenGL renderer on some Windows systems.

Create a set of frames and write each frame to the file.

```
for k = 1:20
 surf(sin(2*pi*k/20)*Z,Z)
 frame = getframe;
 writeVideo(writerObj, frame);
end

close(writerObj);
```

## See Also

[VideoReader](#) | [mmfileinfo](#)

# view

---

**Purpose** Viewpoint specification

**Syntax**

```
view(az,e1)
view([az,e1])
view([x,y,z])
view(2)
view(3)
view(ax,...)
[az,e1] = view
```

**Description** The position of the viewer (the viewpoint) determines the orientation of the axes. You specify the viewpoint in terms of azimuth and elevation, or by a point in three-dimensional space.

`view(az,e1)` and `view([az,e1])` set the viewing angle for a three-dimensional plot. The azimuth, `az`, is the horizontal rotation about the  $z$ -axis as measured in degrees from the negative  $y$ -axis. Positive values indicate counterclockwise rotation of the viewpoint. `e1` is the vertical elevation of the viewpoint in degrees. Positive values of elevation correspond to moving above the object; negative values correspond to moving below the object.

`view([x,y,z])` sets the view direction to the Cartesian coordinates  $x$ ,  $y$ , and  $z$ . The magnitude of  $(x,y,z)$  is ignored.

`view(2)` sets the default two-dimensional view, `az = 0`, `e1 = 90`.

`view(3)` sets the default three-dimensional view, `az = 37.5`, `e1 = 30`.

`view(ax,...)` uses axes `ax` instead of the current axes.

`[az,e1] = view` returns the current azimuth and elevation.

**Tips** Azimuth is a polar angle in the  $x$ - $y$  plane, with positive angles indicating counterclockwise rotation of the viewpoint. Elevation is the angle above (positive angle) or below (negative angle) the  $x$ - $y$  plane.

This diagram illustrates the coordinate system. The arrows indicate positive directions.

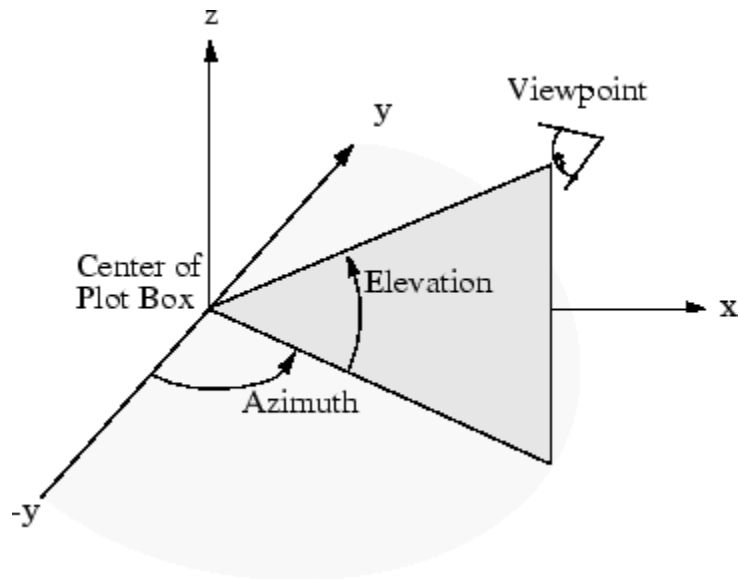

## Examples

View the object from directly overhead.

```
az = 0;
el = 90;
view(az, el);
```

Set the view along the  $y$ -axis, with the  $x$ -axis extending horizontally and the  $z$ -axis extending vertically in the figure.

```
view([0 0]);
```

Rotate the view about the  $z$ -axis by  $180^\circ$ .

```
az = 180;
el = 90;
view(az, el);
```

# view

---

## See Also

[hgtransform](#) | [rotate3d](#) | [CameraPosition](#) | [CameraTarget](#) | [CameraViewAngle](#) | [Projection](#)

## How To

- “View Overview”

**Purpose** View transformation matrices

**Syntax**

```
viewmtx
T = viewmtx(az,e1)
T = viewmtx(az,e1,phi)
T = viewmtx(az,e1,phi,xc)
```

**Description** `viewmtx` computes a 4-by-4 orthographic or perspective transformation matrix that projects four-dimensional homogeneous vectors onto a two-dimensional view surface (e.g., your computer screen).

`T = viewmtx(az,e1)` returns an *orthographic* transformation matrix corresponding to azimuth `az` and elevation `e1`. `az` is the azimuth (i.e., horizontal rotation) of the viewpoint in degrees. `e1` is the elevation of the viewpoint in degrees. This returns the same matrix as the commands

```
view(az,e1)
T = view
```

but does not change the current view.

`T = viewmtx(az,e1,phi)` returns a *perspective* transformation matrix. `phi` is the perspective viewing angle in degrees. `phi` is the subtended view angle of the normalized plot cube (in degrees) and controls the amount of perspective distortion.

Phi	Description
0 degrees	Orthographic projection
10 degrees	Similar to telephoto lens
25 degrees	Similar to normal lens
60 degrees	Similar to wide-angle lens

`T = viewmtx(az,e1,phi,xc)` returns the perspective transformation matrix using `xc` as the target point within the normalized plot cube (i.e., the camera is looking at the point `xc`). `xc` is the target point that is the

center of the view. You specify the point as a three-element vector,  $x_c = [x_c, y_c, z_c]$ , in the interval  $[0,1]$ . The default value is  $x_c = [0,0,0]$ .

A four-dimensional homogenous vector is formed by appending a 1 to the corresponding three-dimensional vector. For example,  $[x, y, z, 1]$  is the four-dimensional vector corresponding to the three-dimensional point  $[x, y, z]$ .

## Examples

Determine the projected two-dimensional vector corresponding to the three-dimensional point  $(0.5, 0.0, -3.0)$  using the default view direction. Note that the point is a column vector.

```
A = viewmtx(-37.5,30);
x4d = [.5 0 -3 1]';
x2d = A*x4d;
x2d = x2d(1:2)
x2d =
 0.3967
 -2.4459
```

These vectors trace the edges of a unit cube:

```
x = [0 1 1 0 0 0 1 1 0 0 1 1 1 1 0 0];
y = [0 0 1 1 0 0 0 1 1 0 0 0 1 1 1 1];
z = [0 0 0 0 0 1 1 1 1 1 1 0 0 1 1 0];
```

Transform the points in these vectors to the screen, then plot the object.

```
A = viewmtx(-37.5,30);
[m,n] = size(x);
x4d = [x(:),y(:),z(:),ones(m*n,1)]';
x2d = A*x4d;
x2 = zeros(m,n); y2 = zeros(m,n);
x2(:) = x2d(1,:);
y2(:) = x2d(2,:);
figure
plot(x2,y2)
```

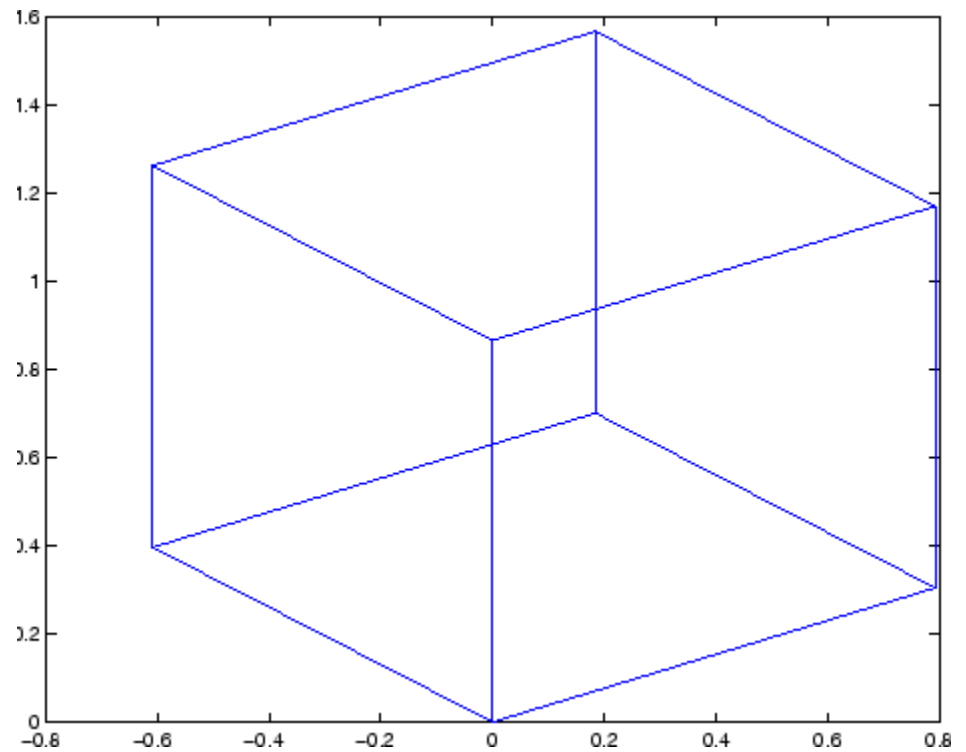

Use a perspective transformation with a 25 degree viewing angle:

```
A = viewmtx(-37.5,30,25);
x4d = [.5 0 -3 1]';
x2d = A*x4d;
x2d = x2d(1:2)/x2d(4) % Normalize
x2d =
 0.1777
 -1.8858
```

Transform the cube vectors to the screen and plot the object:

```
figure
A = viewmtx(-37.5,30,25);
```

```
[m,n] = size(x);
x4d = [x(:),y(:),z(:),ones(m*n,1)]';
x2d = A*x4d;
x2 = zeros(m,n); y2 = zeros(m,n);
x2(:) = x2d(1,:)./x2d(4,:);
y2(:) = x2d(2,:)./x2d(4,:);
plot(x2,y2)
```

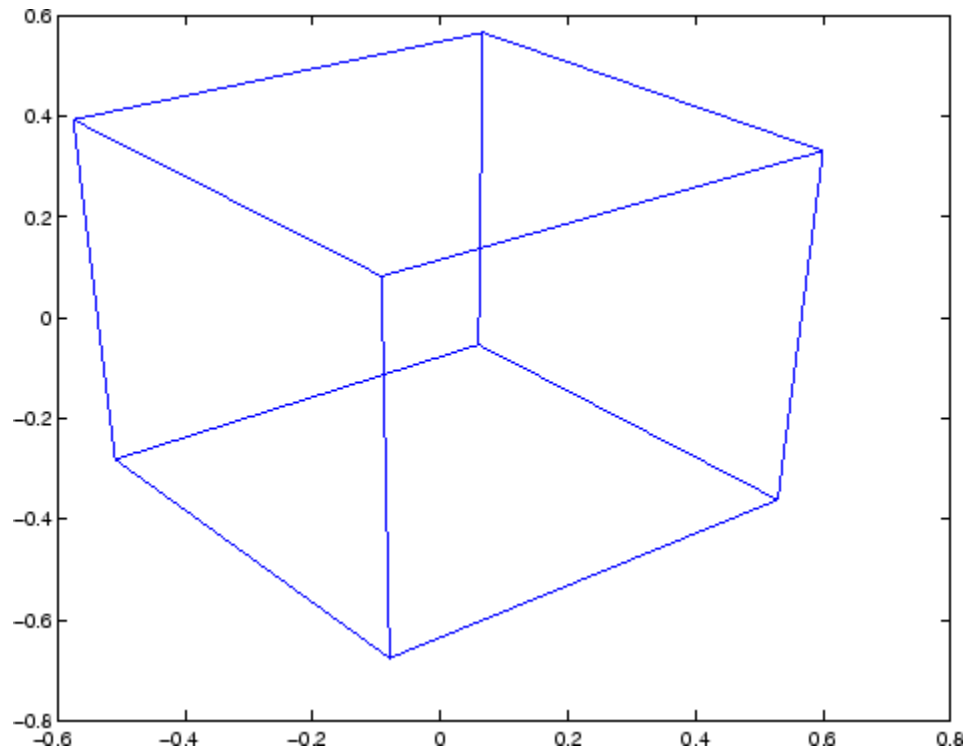

## See Also

[view](#) | [hgtransform](#)

## Tutorials

- “Camera Graphics Terminology”



**Purpose** Compare two text files, MAT-Files, binary files, Zip files, or folders

**Syntax**

```
visdiff('fname1', 'fname2')
visdiff('filename1', 'filename2', 'type')
```

**Description** `visdiff('fname1', 'fname2')` opens the Comparison Tool and presents the differences between the two files or folders. Either ensure that the two files or folders appear on the MATLAB path, or provide the full path for each file or folder. You can compare files or any combination of folders, zip files, or Simulink manifests.

If you have Simulink Report Generator™ software, you can select a pair of Simulink models to compare XML text files generated from them.

`visdiff('filename1', 'filename2', 'type')` opens the Comparison Tool and presents the differences between the two files using the specified comparison type. *type* can be 'text' or 'binary'. If you do not specify *type*, `visdiff` creates the default comparison type for your selected files. The *type* option does not apply when comparing folders.

If there are multiple comparison types available for your selections (e.g., text, binary, file list, or XML comparison), you can create a new comparison and choose a different comparison type.

**1** In the Comparison Tool, click the New comparison button.

The dialog box Select Files or Folders for Comparison opens and shows your previous comparison selections in the drop-down lists.

**2** Change the comparison type and click **Compare**.

## Examples

### Specifying Files or Folders to Compare

The `visdiff` function accepts fully qualified file names, relative file names, or names of files on the MATLAB path.

If the files you want to compare appear on the MATLAB path or in the current folder, you can specify the file names without the full path, for example:

```
visdiff('lengthofline.m', 'lengthofline2.m')
```

or

```
visdiff('lengthofline', 'lengthofline2')
```

If the files you want to compare are not on the path, either specify the full path to each file, or add the folders to the path.

For example, to specify the fully qualified file names to compare two example files:

```
visdiff(fullfile(matlabroot, 'toolbox', 'matlab', 'demos', 'gatlin.mat'), ...
fullfile(matlabroot, 'toolbox', 'matlab', 'demos', 'gatlin2.mat'))
```

Specify the full path to files as follows:

```
visdiff('C:\Work\comp\lengthofline.m', 'C:\Work\comp\lengthofline2.m')
```

You can specify paths to files relative to the current folder. For the preceding example, if the current folder is `Work`, then the relative paths are:

```
visdiff('comp\lengthofline.m', 'comp\lengthofline2.m')
```

### Compare Two Text Files

To view a comparison of the two example files, `lengthofline.m` and `lengthofline2.m`:

```
visdiff(fullfile(matlabroot, 'help', 'techdoc', 'matlab_env', ...
'examples', 'lengthofline.m'), fullfile(matlabroot, 'help', ...
```

```
'techdoc','matlab_env','examples','lengthofline2.m'))
```

For information about using the report features, see “Comparing Text Files”.

---

**Note** If the text files you compare are XML files, you see different results if you have MATLAB Report Generator installed. For details, see “Comparing Files and Folders”.

---

### Compare Two MAT-Files

To compare two example files:

```
visdiff(fullfile(matlabroot,'toolbox','matlab','demos','gatlin.mat'), ...
fullfile(matlabroot,'toolbox','matlab','demos','gatlin2.mat'))
```

For information about the report features, see “Comparing MAT-Files”.

### Compare Two Binary Files

The following example code adds a folder containing two MEX-files to the MATLAB path, and then compares the files:

```
addpath([matlabroot '\extern\examples\shrlib'])
visdiff('shrlibsample.mexw32', 'yprime.mexw32')
```

The Comparison Tool opens and indicates that the files are different, but does not provide details about the differences.

For more information on binary comparisons, see “Comparing Binary Files”.

### Compare Two Folders or Zip Files

You can perform file list comparisons for any combinations of folders and zip files. To view an example folder comparison and instructions for using the report features, see “Comparing Folders and Zip Files”.

## Compare Files and Specify Type

To compare two example text files and specify comparison type as binary:

```
visdiff(fullfile(matlabroot,'help','techdoc','matlab_env',...
'examples','lengthofline.m'), fullfile(matlabroot,'help',...
'techdoc','matlab_env','examples','lengthofline2.m'), 'binary')
```

If you do not specify type, `visdiff` creates the default comparison type for your selected files, in this case, text comparison. By changing to the binary comparison type you could examine differences such as end-of-line characters.

Similarly, when you compare XML files without specifying type, you get a hierarchical XML comparison report. If instead you want a text or binary comparison, you can specify "text" or "binary" comparison types to see more details. When you compare zip files, the default comparison type is a file list comparison, and you might want to specify a binary comparison instead.

## Alternatives

As an alternative to the `visdiff` function, compare files and folders using any of these GUI methods:

- From the Current Folder browser:
  - Select a file or folder. Right-click the file or folder, and select **Compare Against**.
  - For two files or subfolders in the same folder, select the files or folders. Then, right-click, and select **Compare Selected Files/Folders**.
- From the MATLAB desktop, on the **Home** tab, in the **File** section, click **Compare** and then select the files or folders to compare.
- If you have a file open in the Editor, on the **Editor** tab, in the **File** section, click **Compare**. Alternatively, under **Compare**, you can choose a file to compare against, or compare with the autosave

version or the version on disk. See “Comparing Files with Autosave Version or Version on Disk”.

**How To**

- “Comparing Files and Folders”

# volumebounds

---

**Purpose** Coordinate and color limits for volume data

**Syntax**

```
lims = volumebounds(X,Y,Z,V)
lims = volumebounds(X,Y,Z,U,V,W)
lims = volumebounds(V)
lims = volumebounds(U,V,W)
```

**Description** `lims = volumebounds(X,Y,Z,V)` returns the x, y, z, and color limits of the current axes for scalar volume data. `lims` is returned as a vector:

```
[xmin xmax ymin ymax zmin zmax cmin cmax]
```

You can pass this vector to the `axis` command.

`lims = volumebounds(X,Y,Z,U,V,W)` returns the x, y, and z limits of the current axes for vector volume data. `lims` is returned as a vector:

```
[xmin xmax ymin ymax zmin zmax]
```

`lims = volumebounds(V)` and `lims = volumebounds(U,V,W)` assumes X, Y, and Z are determined by the expression

```
[X Y Z] = meshgrid(1:n,1:m,1:p)
```

where `[m n p] = size(V)`.

**Examples** This example uses `volumebounds` to set the axis and color limits for an isosurface generated by the flow function.

```
[x y z v] = flow;
p = patch(isosurface(x,y,z,v,-3));
isonormals(x,y,z,v,p)
daspect([1 1 1])
isocolors(x,y,z,flipplr(v),p)
shading interp
axis(volumebounds(x,y,z,v))
```

**See Also** [isosurface](#) | [streamslice](#)

**Purpose** Voronoi diagram

---

**Note** Qhull-specific options are no longer supported. Remove the `OPTIONS` argument from all instances in your code that pass it to `voronoi`.

---

**Syntax**

```
voronoi(x,y)
voronoi(x,y,TRI)
voronoi(dt)
voronoi(AX,...)
voronoi(...,'LineStyle')
h = voronoi(...)
[vx,vy] = voronoi(...)
```

**Description**

`voronoi(x,y)` plots the bounded cells of the Voronoi diagram for the points `x,y`. Lines-to-infinity are approximated with an arbitrarily distant endpoint.

`voronoi(x,y,TRI)` uses the triangulation `TRI` instead of computing internally.

`voronoi(dt)` uses the Delaunay triangulation `dt` instead of computing it.

`voronoi(AX,...)` plots into `AX` instead of `gca`.

`voronoi(...,'LineStyle')` plots the diagram with color and line style specified.

`h = voronoi(...)` returns, in `h`, handles to the line objects created.

`[vx,vy] = voronoi(...)` returns the finite vertices of the Voronoi edges in `vx` and `vy`.

---

**Note** For the topology of the Voronoi diagram, i.e., the vertices for each Voronoi cell, use `voronoin`.

```
[v,c] = voronoin([x(:) y(:)])
```

---

## Definitions

Consider a set of coplanar points  $P$ . For each point  $P_x$  in the set  $P$ , you can draw a boundary enclosing all the intermediate points lying closer to  $P_x$  than to other points in the set  $P$ . Such a boundary is called a *Voronoi polygon*, and the set of all Voronoi polygons for a given point set is called a *Voronoi diagram*.

## Visualization

Use one of these methods to plot a Voronoi diagram:

- If you provide no output argument, `voronoi` plots the diagram.
- To gain more control over color, line style, and other figure properties, use the syntax `[vx,vy] = voronoi(...)`. This syntax returns the vertices of the finite Voronoi edges, which you can then plot with the `plot` function.
- To fill the cells with color, use `voronoin` with `n = 2` to get the indices of each cell, and then use `patch` and other plot functions to generate the figure. Note that `patch` does not fill unbounded cells with color.

## Examples

### Voronoi Diagram Based on Points

This code uses the `voronoi` function to plot the Voronoi diagram for 10 randomly generated points.

```
x = gallery('uniformdata',[1 10],0);
y = gallery('uniformdata',[1 10],1);
voronoi(x,y)
```



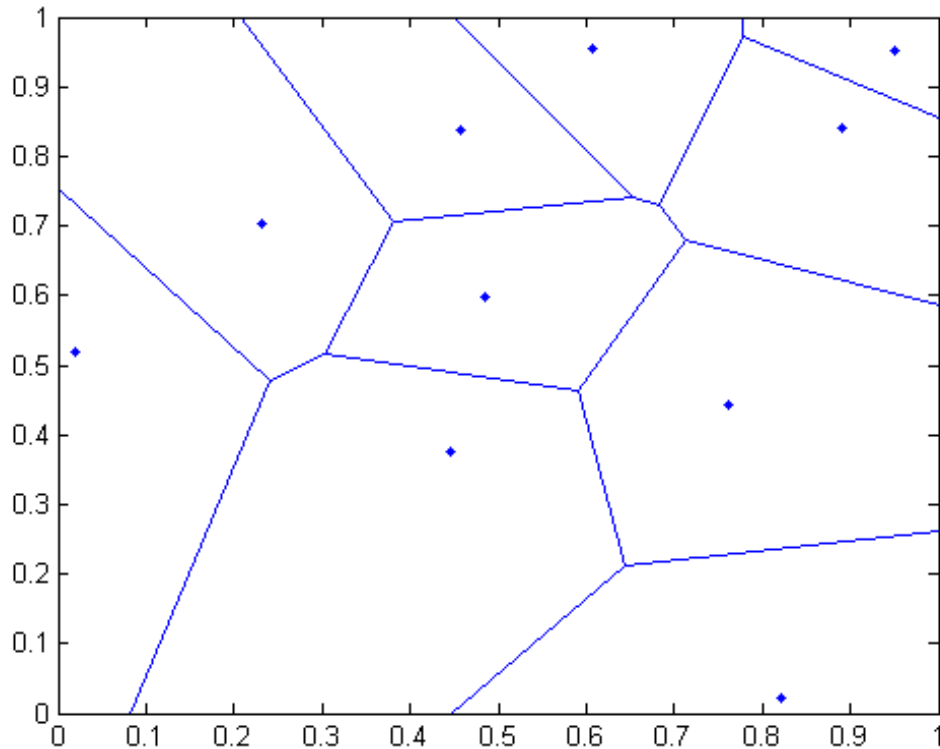

### Voronoi Diagram Based on Vertices of Veronoi Edges

This code uses the vertices of the finite Voronoi edges to plot the Voronoi diagram for the same 10 points used in the previous example.

```
x = gallery('uniformdata',[1 10],0);
y = gallery('uniformdata',[1 10],1);
[vx, vy] = voronoi(x,y);
plot(x,y,'r+',vx,vy,'b-'); axis equal
```

# voronoi

---

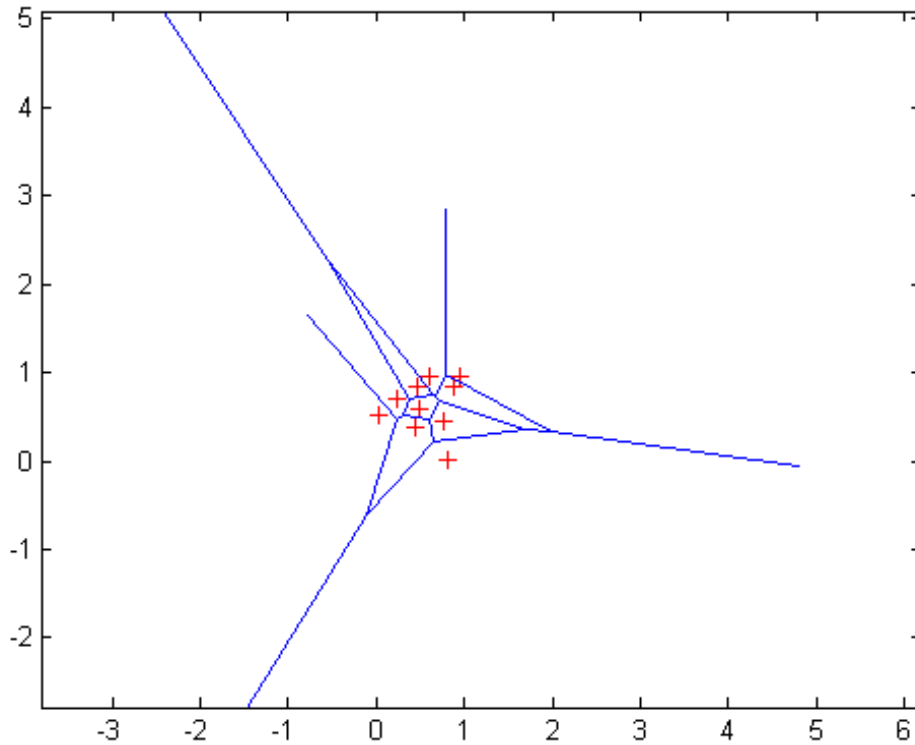

Note that you can add the following code to get the figure shown in the previous example.

```
xlim([min(x) max(x)])
ylim([min(y) max(y)])
```

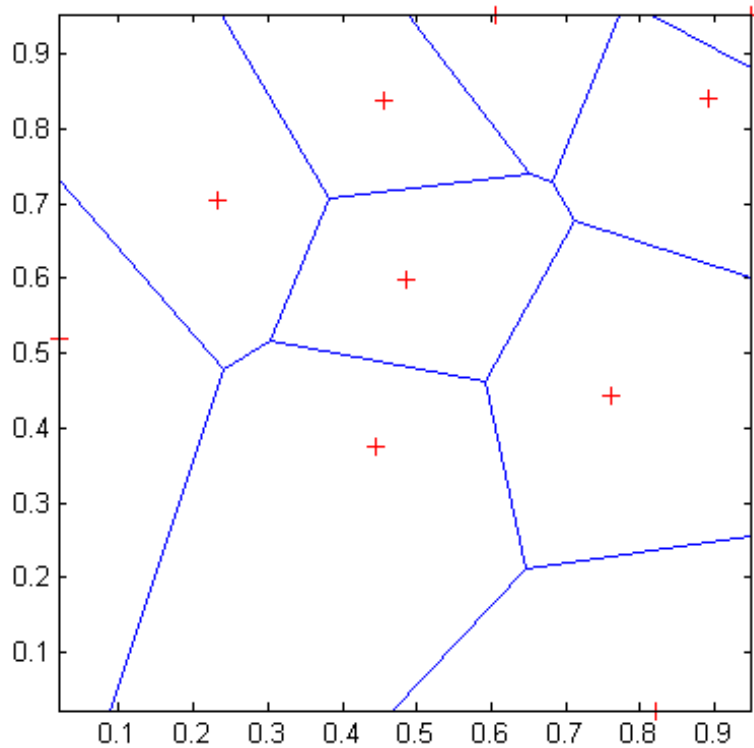

### Voronoi Diagram with Color

This code uses `voronoin` and `patch` to fill the bounded cells of the same Voronoi diagram with color.

```
x = gallery('uniformdata',[10 2],5);
[v,c]=voronoin(x);
for i = 1:length(c)
 if all(c{i}~=1) % If at least one of the indices is 1,
 % then it is an open region and we can't
```

# voronoi

---

```
 % patch that.
patch(v(c{i},1),v(c{i},2),i); % use color i.
end
end
```

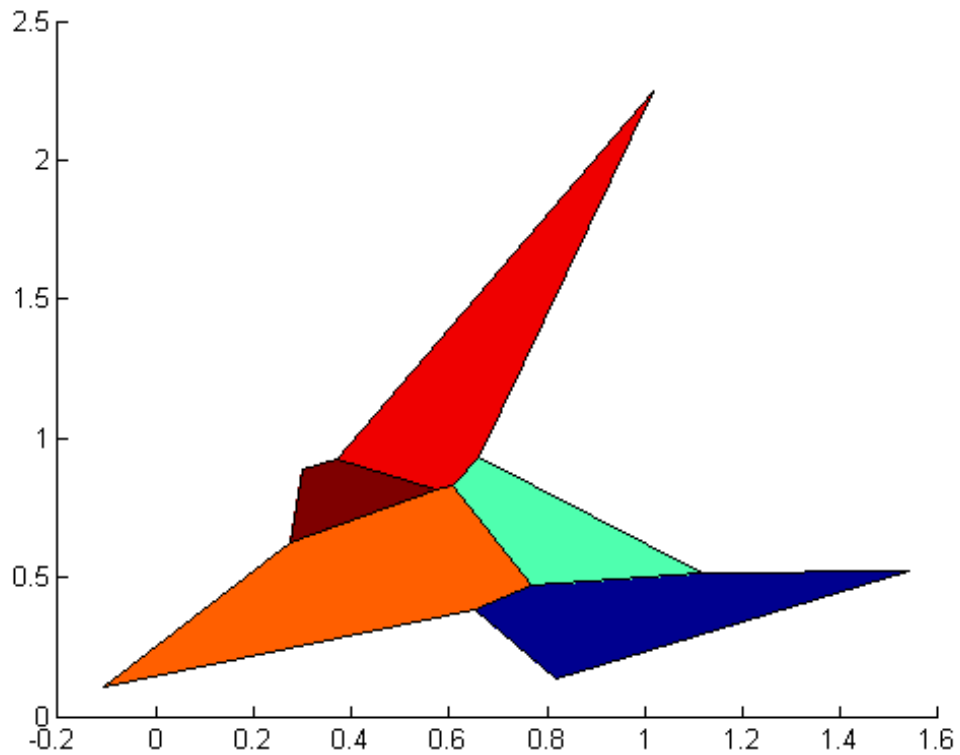

## See Also

[delaunayTriangulation](#) | [convhull](#) | [delaunay](#) | [LineStyle](#) | [plot](#)  
| [voronoin](#)

**Purpose** (Will be removed) Voronoi diagram

---

**Note** `voronoiDiagram(DelaunayTri)` will be removed in a future release. Use `voronoiDiagram(delaunayTriangulation)` instead.

`DelaunayTri` will be removed in a future release. Use `delaunayTriangulation` instead.

---

**Syntax** `[V, R] = voronoiDiagram(DT)`

**Description** `[V, R] = voronoiDiagram(DT)` returns the vertices `V` and regions `R` of the Voronoi diagram of the points `DT.X`. The region `R{i}` is a cell array of indices into `V` that represents the Voronoi vertices bounding the region. The Voronoi region associated with the `i`'th point, `DT.X(i)` is `R{i}`. For 2-D, vertices in `R{i}` are listed in adjacent order, i.e. connecting them will generate a closed polygon (Voronoi diagram). For 3-D the vertices in `R{i}` are listed in ascending order.

The Voronoi regions associated with points that lie on the convex hull of `DT.X` are unbounded. Bounding edges of these regions radiate to infinity. The vertex at infinity is represented by the first vertex in `V`.

**Input Arguments**

<code>DT</code>	Delaunay triangulation.
-----------------	-------------------------

# DelaunayTri.voronoiDiagram

---

## Output Arguments

V	numv-by-ndim matrix representing the coordinates of the Voronoi vertices, where numv is the number of vertices and ndim is the dimension of the space where the points reside.
R	Vector cell array of length(DR.X), representing the Voronoi cell associated with each point.

## Definitions

The *Voronoi diagram* of a discrete set of points  $X$  decomposes the space around each point  $X(i)$  into a region of influence  $R\{i\}$ . Locations within the region are closer to point  $i$  than any other point. The region of influence is called the Voronoi region. The collection of all the Voronoi regions is the Voronoi diagram.

The *convex hull* of a set of points  $X$  is the smallest convex polygon (or polyhedron in higher dimensions) containing all of the points of  $X$ .

## Examples

Compute the Voronoi Diagram of a set of points:

```
X = [0.5 0
 0 0.5
 -0.5 -0.5
 -0.2 -0.1
 -0.1 0.1
 0.1 -0.1
 0.1 0.1]
dt = DelaunayTri(X)
[V,R] = voronoiDiagram(dt)
```

## See Also

[voronoi](#) | [voronoin](#) | [triangulation](#) | [delaunayTriangulation](#)

**Purpose**

N-D Voronoi diagram

**Syntax**

[V,C] = voronoin(X)  
 [V,C] = voronoin(X,options)

**Description**

[V,C] = voronoin(X) returns Voronoi vertices V and the Voronoi cells C of the Voronoi diagram of X. V is a numv-by-n array of the numv Voronoi vertices in n-dimensional space, each row corresponds to a Voronoi vertex. C is a vector cell array where each element contains the indices into V of the vertices of the corresponding Voronoi cell. X is an m-by-n array, representing m n-dimensional points, where n > 1 and m >= n+1.

The first row of V is a point at infinity. If any index in a cell of the cell array is 1, then the corresponding Voronoi cell contains the first point in V, a point at infinity. This means the Voronoi cell is unbounded.

voronoin uses Qhull.

[V,C] = voronoin(X,options) specifies a cell array of strings options to be used in Qhull. The default options are

- {'Qbb'} for 2- and 3-dimensional input
- {'Qbb','Qx'} for 4 and higher-dimensional input

If options is [], the default options are used. If code is {''}, no options are used, not even the default. For more information on Qhull and its options, see <http://www.qhull.org>.

**Visualization**

You can plot individual bounded cells of an n-dimensional Voronoi diagram. To do this, use convhulln to compute the vertices of the facets that make up the Voronoi cell. Then use patch and other plot functions to generate the figure.

**Examples**

**Example 1**

Let

```
x = [0.5 0
 0 0.5
```

# voronoin

---

```
-0.5 -0.5
-0.2 -0.1
-0.1 0.1
 0.1 -0.1
 0.1 0.1]
```

then

```
[V,C] = voronoin(x)
```

V =

```
 Inf Inf
 0.3833 0.3833
 0.7000 -1.6500
 0.2875 0.0000
-0.0000 0.2875
-0.0000 -0.0000
-0.0500 -0.5250
-0.0500 -0.0500
-1.7500 0.7500
-1.4500 0.6500
```

C =

```
[1x4 double]
[1x5 double]
[1x4 double]
[1x4 double]
[1x4 double]
[1x5 double]
[1x4 double]
```

Use a for loop to see the contents of the cell array C.

```
for i=1:length(C), disp(C{i}), end
```

```
 4 2 1 3
10 5 2 1 9
 9 1 3 7
```



```

10 8 7 9
10 5 6 8
 8 6 4 3 7
 6 4 2 5

```

In particular, the fifth Voronoi cell consists of 4 points:  $V(10, :)$ ,  $V(5, :)$ ,  $V(6, :)$ ,  $V(8, :)$ .

### Example 2

The following example illustrates the options input to voronoin. The commands

```

X = [-1 -1; 1 -1; 1 1; -1 1];
[V,C] = voronoin(X)

```

return an error message.

```

? qhull input error: can not scale last coordinate. Input is
cocircular
 or cospherical. Use option 'Qz' to add a point at infinity.

```

The error message indicates that you should add the option 'Qz'. The following command passes the option 'Qz', along with the default 'Qbb', to voronoin.

```

[V,C] = voronoin(X,{'Qbb','Qz'})
V =

```

```

 Inf Inf
 0 0

```

C =

```

[1x2 double]
[1x2 double]
[1x2 double]
[1x2 double]

```

# voronoin

---

## Algorithms

voronoin is based on Qhull [1]. For information about Qhull, see <http://www.qhull.org/>.

## References

[1] Barber, C. B., D.P. Dobkin, and H.T. Huhdanpaa, "The Quickhull Algorithm for Convex Hulls," *ACM Transactions on Mathematical Software*, Vol. 22, No. 4, Dec. 1996, p. 469-483.

## See Also

delaunayTriangulation | convhull | convhulln | delaunay | delaunayn | voronoi

**Purpose**

Open or update wait bar dialog box

**Syntax**

```
h = waitbar(x,'message')
waitbar(x,'message','CreateCancelBtn','button_callback')
waitbar(x,'message',property_name,property_value,...)
waitbar(x)
waitbar(x,h)
waitbar(x,h,'updated message')
```

**Description**

A wait bar is a figure that displays what percentage of a calculation is complete as the calculation proceeds by progressively filling a bar with red from left to right.

`h = waitbar(x,'message')` displays a wait bar of fractional length `x`. The wait bar figure displays until the code that controls it closes it or the user clicks its Close Window button. Its (figure) handle is returned in `h`. The argument `x` must be between 0 and 1.

---

**Note** Wait bars are not modal figures (their `WindowState` is 'normal'). They often appear to be modal because the computational loops within which they are called prevent interaction with the Command Window until they terminate. For more information, see `WindowState` in the MATLAB Figure Properties documentation.

---

`waitbar(x,'message','CreateCancelBtn','button_callback')` specifying `CreateCancelBtn` adds a **Cancel** button to the figure that executes the MATLAB commands specified in `button_callback` when the user clicks the **Cancel** button or the **Close Figure** button. `waitbar` sets both the **Cancel** button callback and the figure `CloseRequestFcn` to the string specified in `button_callback`.

`waitbar(x,'message',property_name,property_value,...)` optional arguments `property_name` and `property_value` enable you to set figure properties for the waitbar.

# waitbar

---

`waitbar(x)` subsequent calls to `waitbar(x)` extend the length of the bar to the new position `x`. Successive values of `x` normally increase. If they decrease, the wait bar runs in reverse.

`waitbar(x,h)` extends the length of the bar in the wait bar `h` to the new position `x`.

`waitbar(x,h,'updated message')` updates the message text in the waitbar figure, in addition to setting the fractional length to `x`.

## Examples

### Example 1 – Basic Wait Bar

Typically, you call `waitbar` repeatedly inside a `for` loop that performs a lengthy computation. For example:

```
h = waitbar(0,'Please wait...');
steps = 1000;
for step = 1:steps
 % computations take place here
 waitbar(step / steps)
end
close(h)
```

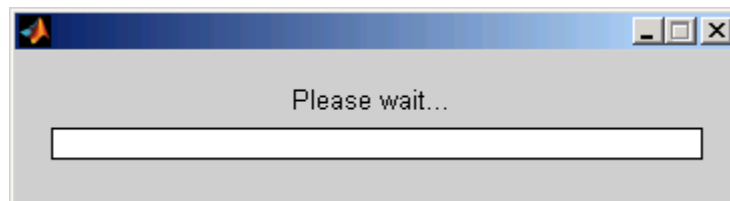

### Example 2 – Wait Bar with Dynamic Text and Cancel Button

Adding a **Cancel** button allows user to abort the computation. Clicking it sets a logical flag in the figure's application data (`appdata`). The function tests for that value within the main loop and exits the loop as soon as the flag has been set. The example iteratively approximates the value of  $\pi$ . At each step, the current value is encoded as a string and displayed in the wait bar's message field. When the function finishes,

it destroys the wait bar and returns the current estimate of  $\pi$  and the number of steps it ran.

Copy the following function to a code file and save it as `approxpi.m`. Execute it as follows, allowing it to run for 10,000 iterations.

```
[estimated_pi steps] = approxpi(10000)
```

You can click **Cancel** or close the window to abort the computation and return the current estimate of  $\pi$ .

```
function [valueofpi step] = approxpi(steps)
% Converge on pi in steps iterations, displaying waitbar.
% User can click Cancel or close button to exit the loop.
% Ten thousand steps yields error of about 0.001 percent.

h = waitbar(0,'1','Name','Approximating pi...',...
 'CreateCancelBtn',...
 'setappdata(gcf,'canceling',1)');
setappdata(h,'canceling',0)
% Approximate as $\pi^2/8 = 1 + 1/9 + 1/25 + 1/49 + \dots$
pisqover8 = 1;
denom = 3;
valueofpi = sqrt(8 * pisqover8);
for step = 1:steps
 % Check for Cancel button press
 if getappdata(h,'canceling')
 break
 end
 % Report current estimate in the waitbar's message field
 waitbar(step/steps,h,sprintf('%12.9f',valueofpi))
 % Update the estimate
 pisqover8 = pisqover8 + 1 / (denom * denom);
 denom = denom + 2;
 valueofpi = sqrt(8 * pisqover8);
end
delete(h) % DELETE the waitbar; don't try to CLOSE it.
```

# waitbar

---

The function sets the figure Name property to describe what is being computed. In the for loop, calling waitbar sets the fractional progress indicator and displays intermediate results. the code `waitbar(i/steps,h,sprintf('%12.9f',valueofpi))` sets the wait bar's message variable to a string representation of the current estimate of  $\pi$ . Naturally, the extra computation involved makes iterations last longer than they need to, but such feedback can be helpful to users.

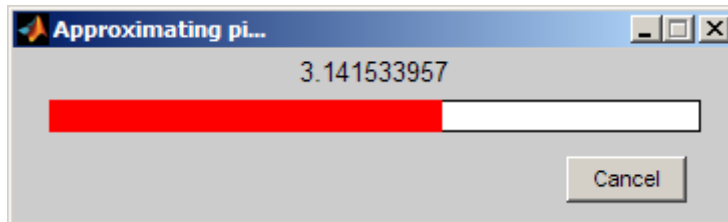

---

**Note** You should call `delete` to remove a wait bar when you give it a `CloseRequestFcn`, as in the preceding code; calling `close` does not close it, and makes its Cancel and Close Window buttons unresponsive. This happens because the figure's `CloseRequestFcn` recursively calls itself. In such a situation you must forcibly remove the wait bar, for example like this:

```
set(0,'ShowHiddenHandles','on')
delete(get(0,'Children'))
```

However, as issuing these commands will delete all open figures—not just the wait bar—it is best never to use `close` in a `CloseRequestFcn` to close a window.

---

## See Also

`close` | `delete` | `dialog` | `msgbox` | `getappdata` | `setappdata`

**Purpose**

Block execution and wait for event or condition

**Syntax**

```
waitfor(h)
waitfor(h, 'PropertyName')
waitfor(h, 'PropertyName', PropertyValue)
```

**Description**

`waitfor(h)` blocks the caller from executing statements until the graphics object identified by handle `h` closes (is deleted). `h` must be scalar. When object `h` no longer exists, `waitfor` returns, enabling execution to resume. If the object does not exist, `waitfor` returns immediately without processing any events.

`waitfor(h, 'PropertyName')` blocks the caller from executing until the value of `'PropertyName'` (any property of the graphics object `h`) changes or `h` closes (is deleted). If `'PropertyName'` is not a valid property for the object, `waitfor` returns immediately without processing any events.

`waitfor(h, 'PropertyName', PropertyValue)` blocks the caller from executing until the value of `'PropertyName'` for the graphics object `h` changes to the specific value `PropertyValue` or `h` closes (is deleted). If the value of `'PropertyName'` is already `PropertyValue`, `waitfor` returns immediately without processing any events.

**Definitions**

- `waitfor` blocks execution so that command-line expressions and subsequent statements in the blocked file do not execute until a specified condition occurs.
- While `waitfor` prevents its caller from continuing, callbacks that respond to various events (for example, pressing a mouse button) can still run, unaffected by `waitfor`.
- `waitfor` also blocks Simulink models from executing, but callbacks do still execute.
- `waitfor` can block nested function calls. For example, a callback invoked while `waitfor` is active can invoke `waitfor`.
- If you type **Ctrl+C** in the Command Window while `waitfor` is blocking execution, the executing program terminates. To avoid

terminating, the program can call `waitfor` within a `try/catch` block that handles the exception that typing **Ctrl+C** generates. To learn more, see the third following example.

## Examples

Create a plot and pause execution of the rest of the statements until you close the figure window:

```
f = warndlg('This is a warning.', 'A Warning Dialog');
disp('This prints immediately');
drawnow % Necessary to print the message
waitfor(f);
disp('This prints after you close the warning dialog');
```

---

Suspend execution until name of figure changes:

```
f = figure('Name', datestr(now));
h = uicontrol('String','Change Name',...
 'Position',[20 20 100 30],...
 'Callback', 'set(gcf, 'Name', datestr(now))');
disp('This prints immediately');
drawnow % Necessary to print the message
waitfor(f, 'Name');
disp('This prints after button click that changes the figure''s name');
```

---

Display text object and wait for user to edit it:

```
figure;
textH = text(.5, .5, 'Edit me and click away');
set(textH,'Editing','on', 'BackgroundColor',[1 1 1]);
disp('This prints immediately. ');
drawnow
waitfor(textH,'Editing','off');
set(textH,'BackgroundColor',[1 1 0]);
```



```
disp('This prints after text editing is complete.');
```

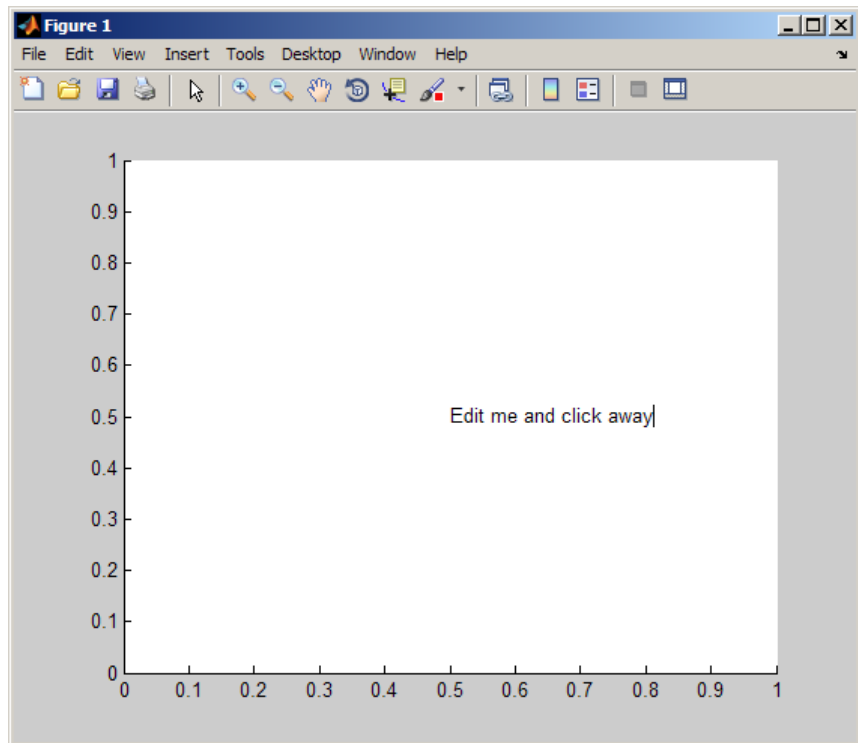

If you close the figure while `waitfor` is executing, an error occurs because the code attempts to access handles of objects that no longer exist. You can handle the error by enclosing code starting with the call to `waitfor` in a `try/catch` block, as follows:

```
figure;
textH = text(.5, .5, 'Edit me and click away');
set(textH, 'Editing', 'on', 'BackgroundColor', [1 1 1]);
disp('This prints immediately.');
```

`drawnow`  
% Use `try/catch` block to handle errors,  
% such as deleting figure

# waitfor

---

```
try
 waitfor(textH,'Editing','off');
 set(textH,'BackgroundColor',[1 1 0]);
 disp('This prints after text editing is complete.');
```

catch ME

```
 disp('This prints if figure is deleted:')
 disp(ME.message)
 % You can place other code to respond to the error here
end
```

The ME variable is a MATLAB Exception object that you can use to determine the type of error that occurred. For more information, see “Respond to an Exception”.

## See Also

`drawnow` | `keyboard` | `pause` | `uiresume` | `uiwait` | `waitforbuttonpress`

## How To

- “Control Callback Execution and Interruption”

<b>Purpose</b>	Wait for key press or mouse-button click
<b>Syntax</b>	<code>k = waitforbuttonpress</code>
<b>Description</b>	<p><code>k = waitforbuttonpress</code> blocks the caller's execution stream until the function detects that the user has clicked a mouse button or pressed a key while the figure window is active. The function returns</p> <ul style="list-style-type: none"><li>• 0 if it detects a mouse button click</li><li>• 1 if it detects a key press</li></ul> <p>If a <code>WindowButtonDownFcn</code> is defined for the figure, its callback is executed before <code>waitforbuttonpress</code> returns a value.</p> <p>Only keys that generate characters cause the function to return. Pressing any of the following keys by itself does nothing: <b>Ctrl</b>, <b>Shift</b>, <b>Alt</b>, <b>Caps_lock</b>, <b>Num_lock</b>, <b>Scroll_lock</b>.</p> <p>Additional information about the event that causes execution to resume is available through the figure <code>CurrentCharacter</code>, <code>SelectionType</code>, and <code>CurrentPoint</code> properties.</p> <p>You can interrupt <code>waitforbuttonpress</code> by typing <b>Ctrl+C</b>, but an error results unless the function is called from within a <code>try/catch</code> block. You also receive an error from <code>waitforbuttonpress</code> if you close the figure by clicking the <b>X</b> close box unless you call <code>waitforbuttonpress</code> within a <code>try/catch</code> block.</p>

**Examples** These statements display text in the Command Window when the user either clicks a mouse button or types a key in the figure window:

```
w = waitforbuttonpress;
if w == 0
 disp('Button click')
else
 disp('Key press')
end
```

# waitforbuttonpress

---

## See Also

`dragrect` | `ginput` | `rbbox` | `waitfor`

## Purpose

Open warning dialog box

## Syntax

```
h = warndlg
h = warndlg(warningstring)
h = warndlg(warningstring,dlgname)
h = warndlg(warningstring,dlgname,createmode)
```

## Description

`h = warndlg` displays a dialog box named Warning Dialog containing the string `This is the default warning string`. The `warndlg` function returns the handle of the dialog box in `h`. The warning dialog box disappears after the user clicks **OK**.

`h = warndlg(warningstring)` displays a dialog box with the title Warning Dialog containing the string specified by `warningstring`. The `warningstring` argument can be any valid string format – cell arrays are preferred.

To use multiple lines in your warning, define `warningstring` using either of the following:

- `sprintf` with newline characters separating the lines

```
warndlg(sprintf('Message line 1 \n Message line 2'))
```

- Cell arrays of strings

```
warndlg({'Message line 1';'Message line 2'})
```

`h = warndlg(warningstring,dlgname)` displays a dialog box with title `dlgname`.

`h = warndlg(warningstring,dlgname,createmode)` specifies whether the warning dialog box is modal or nonmodal. Optionally, it can also specify an interpreter for `warningstring` and `dlgname`. The `createmode` argument can be a string or a structure.

If `createmode` is a string, it must be one of the values shown in the following table.

createmode Value	Description
modal	Replaces the warning dialog box having the specified Title, that was last created or clicked on, with a modal warning dialog box as specified. All other warning dialog boxes with the same title are deleted. The dialog box which is replaced can be either modal or nonmodal.
non-modal (default)	Creates a new nonmodal warning dialog box with the specified parameters. Existing warning dialog boxes with the same title are not deleted.
replace	Replaces the warning dialog box having the specified Title, that was last created or clicked on, with a nonmodal warning dialog box as specified. All other warning dialog boxes with the same title are deleted. The dialog box which is replaced can be either modal or nonmodal.

---

**Note** A modal dialog box prevents the user from interacting with other windows before responding. To block MATLAB program execution as well, use the `uiwait` function.

If you open a dialog with `errordlg`, `msgbox`, or `warndlg` using 'CreateMode', 'modal' and a non-modal dialog created with any of these functions is already present and *has the same name as the modal dialog*, the non-modal dialog closes when the modal one opens.

For more information about modal dialog boxes, see `WindowState` in the Figure Properties.

---

If `CreateMode` is a structure, it can have fields `WindowStyle` and `Interpreter`. `WindowStyle` must be one of the options shown in the table above. `Interpreter` is one of the strings 'tex' or 'none'. The default value for `Interpreter` is 'none'.

## Examples

The statement

```
warndlg('Pressing OK will clear memory','!! Warning !!')
```

displays this dialog box:



## See Also

[dialog](#) | [errorDlg](#) | [helpDlg](#) | [inputDlg](#) | [listDlg](#) | [msgBox](#) | [questDlg](#) | [figure](#) | [uiwait](#) | [uiresume](#) | [warning](#)

# warning

---

**Purpose** Warning message

**Syntax**

```
warning('message')
warning('message', a1, a2,...)
warning('message_id', 'message')
warning('message_id', 'message', a1, a2, ..., an)
s = warning(state, 'message_id')
s = warning(state, mode)
```

**Description**

`warning('message')` displays descriptive text message and sets the warning state that `lastwarn` returns. If `message` is an empty string (`''`), `warning` resets the warning state but does not display any text.

`warning('message', a1, a2,...)` displays a message string that contains formatting conversion characters, such as those used with the MATLAB `sprintf` function. Each conversion character in `message` is converted to one of the values `a1, a2, ...` in the argument list.

---

**Note** MATLAB converts special characters (like `\n` and `%d`) in the warning message string only when you specify more than one input argument with `warning`. See Example 3 below.

---

`warning('message_id', 'message')` attaches a unique identifier, or `message_id`, to the warning message. The identifier enables you to single out certain warnings during the execution of your program, controlling what happens when the warnings are encountered.

`warning('message_id', 'message', a1, a2, ..., an)` includes formatting conversion characters in `message`, and the character translations in arguments `a1, a2, ..., an`.

`s = warning(state, 'message_id')` is a warning control statement that enables you to indicate how you want MATLAB to act on certain warnings. The `state` argument can be `'on'`, `'off'`, or `'query'`. The `message_id` argument can be a message identifier string, `'all'`, or `'last'`.



Output `s` is a structure array that indicates the previous state of the selected warnings. The structure has the fields `identifier` and `state`.

`s = warning(state, mode)` is a warning control statement that enables you to display a stack trace or display more information with each warning. The `state` argument can be `'on'`, `'off'`, or `'query'`. The `mode` argument can be `'backtrace'` or `'verbose'`.

## Examples

### Example 1

Generate a warning that displays a simple string:

```
if ~ischar(p1)
 warning('Input must be a string')
end
```

### Example 2

Generate a warning string that is defined at run-time. The first argument defines a message identifier for this warning:

```
warning('MATLAB:paramAmbiguous', ...
 'Ambiguous parameter name, "%s".', param)
```

### Example 3

MATLAB converts special characters (like `\n` and `%d`) in the warning message string only when you specify more than one input argument with `warning`. In the single argument case shown below, `\n` is taken to mean `backslash-n`. It is not converted to a newline character:

```
warning('In this case, the newline \n is not converted.')
Warning: In this case, the newline \n is not converted.
```

But, when more than one argument is specified, MATLAB does convert special characters. This is true regardless of whether the additional argument supplies conversion values or is a message identifier:

```
warning('WarnTests:convertTest', ...
 'In this case, the newline \n is converted.')
Warning: In this case, the newline
```

# warning

---

is converted.

## Example 4

Turn on one particular warning, saving the previous state of this one warning in `s`. Remember that this nonquery syntax performs an implicit query prior to setting the new state:

```
s = warning('on', 'Control:parameterNotSymmetric');
```

After doing some work that includes making changes to the state of some warnings, restore the original state of all warnings:

```
warning(s)
```

## See Also

`lastwarn` | `warndlg` | `error` | `lasterror` | `errordlg` | `dbstop` | `disp` | `sprintf`

## Related Examples

- “Issue Warnings and Errors”
- “Suppress Warnings”
- “Restore Warnings”
- “Change How Warnings Display”

**Purpose** Waterfall plot



**Syntax**

```
waterfall(Z)
waterfall(X,Y,Z)
waterfall(...,C)
waterfall(axes_handles,...)
h = waterfall(...)
```

**Description** The `waterfall` function draws a mesh similar to the `meshz` function, but it does not generate lines from the columns of the matrices. This produces a “waterfall” effect.

`waterfall(Z)` creates a waterfall plot using  $x = 1:\text{size}(Z,2)$  and  $y = 1:\text{size}(Z,1)$ .  $Z$  determines the color, so color is proportional to surface height.

`waterfall(X,Y,Z)` creates a waterfall plot using the values specified in  $X$ ,  $Y$ , and  $Z$ .  $Z$  also determines the color, so color is proportional to the surface height. If  $X$  and  $Y$  are vectors,  $X$  corresponds to the columns of  $Z$ , and  $Y$  corresponds to the rows, where  $\text{length}(x) = n$ ,  $\text{length}(y) = m$ , and  $[m,n] = \text{size}(Z)$ .  $X$  and  $Y$  are vectors or matrices that define the  $x$ - and  $y$ -coordinates of the plot.  $Z$  is a matrix that defines the  $z$ -coordinates of the plot (i.e., height above a plane). If  $C$  is omitted, color is proportional to  $Z$ .

`waterfall(...,C)` uses scaled color values to obtain colors from the current colormap. Color scaling is determined by the range of  $C$ , which must be the same size as  $Z$ . MATLAB performs a linear transformation on  $C$  to obtain colors from the current colormap.

`waterfall(axes_handles,...)` plots into the axes with handle `axes_handle` instead of the current axes (`gca`).

`h = waterfall(...)` returns the handle of the patch graphics object used to draw the plot.

# waterfall

---

## Tips

For column-oriented data analysis, use `waterfall(Z')` or `waterfall(X',Y',Z')`.

## Examples

Produce a waterfall plot of the peaks function.

```
figure
[X,Y,Z] = peaks(30);
waterfall(X,Y,Z)
```

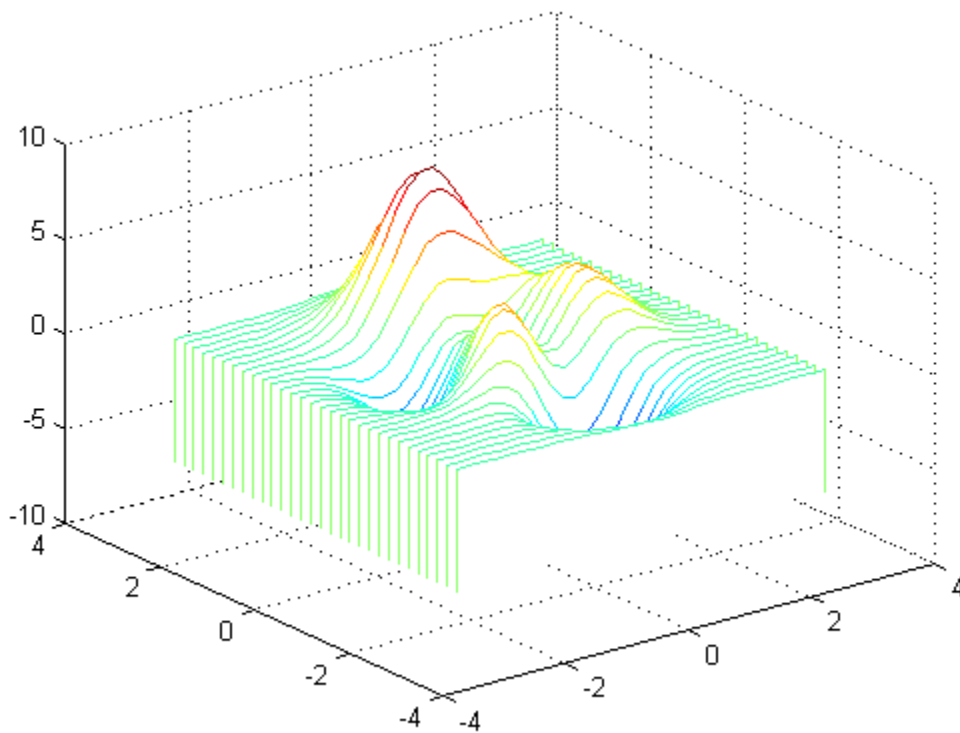

## Algorithms

The range of `X`, `Y`, and `Z`, or the current setting of the axes `Xlim`, `Ylim`, and `Zlim` properties, determines the range of the axes (also set by `axis`). The range of `C`, or the current setting of the axes `CLim` property, determines the color scaling (also set by `caxis`).

The `CData` property for the patch graphics objects specifies the color at every point along the edge of the patch, which determines the color of the lines.

The `waterfall` plot looks like a mesh surface; however, it is a patch graphics object. To create a surface plot similar to `waterfall`, use the `meshz` function and set the `MeshStyle` property of the surface to `'Row'`. For a discussion of parametric surfaces and related color properties, see `surf`.

## See Also

`axes` | `axis` | `caxis` | `meshz` | `ribbon` | `surf`

# wavinfo

---

**Purpose** Information about WAVE (.wav) sound file

---

**Note** `wavinfo` will be removed in a future release. Use `audioinfo` instead.

---

**Syntax** `[m d] = wavinfo(filename)`

**Description** `[m d] = wavinfo(filename)` returns information about the contents of the WAVE sound file specified by the string *filename*. Enclose the *filename* input in single quotes.

*m* is the string 'Sound (WAV) file', if *filename* is a WAVE file. Otherwise, it contains an empty string ('').

*d* is a string that reports the number of samples in the file and the number of channels of audio data. If *filename* is not a WAVE file, it contains the string 'Not a WAVE file'.

**See Also** `audioplayer` | `audiorecorder` | `audioread` | `audiowrite`

**Purpose** Play recorded sound on PC-based audio output device

---

**Note** wavplay has been removed. Use audioplayer instead.

---

**Syntax**

```
wavplay(y,Fs)
wavplay(y,Fs,mode)
```

**Description** wavplay(y,Fs) plays the audio signal stored in the vector y on a PC-based audio output device. Fs is the integer sample rate in Hz (samples per second). The default value for Fs is 11025 Hz. wavplay supports only 1- or 2-channel (mono or stereo) audio signals. To play in stereo, y must be a two-column matrix.

wavplay(y,Fs,mode) specifies how wavplay interacts with the command line. The string mode is one of the following:

- 'sync' (default): You do not have access to the command line until the sound has finished playing (a blocking device call).
- 'async': You have immediate access to the command line as soon as the sound begins to play on the audio output device (a nonblocking device call). If you call wavplay again in async mode while the audio is playing, wavplay blocks access to the command line until the original playback completes.

The audio signal y can be one of four data types. The number of bits used to quantize and play back each sample depends on the data type.

#### Data Types for wavplay

Data Type	Quantization
Double-precision (default value)	16 bits/sample
Single-precision	16 bits/sample
16-bit signed integer	16 bits/sample
8-bit unsigned integer	8 bits/sample

# wavplay

---

## Tips

The wavplay function is for use only with 32-bit Microsoft Windows operating systems. To play audio data on other platforms, use audioplayer.

## Examples

The MAT-files gong.mat and chirp.mat both contain an audio signal y and a sampling frequency Fs. Load and play the gong and the chirp audio signals. Change the names of these signals in between load commands and play them sequentially using the 'sync' option for wavplay.

```
load chirp;
y1 = y; Fs1 = Fs;
load gong;
wavplay(y1,Fs1,'sync') % The chirp signal finishes before the
wavplay(y,Fs) % gong signal begins playing.
```

## See Also

[audioplayer](#) | [audioinfo](#) | [audioread](#) | [audiowrite](#)



**Purpose** Read WAVE (.wav) sound file

---

**Note** wavread will be removed in a future release. Use audioread instead.

---

**Syntax**

```
y = wavread(filename)
[y, Fs] = wavread(filename)
[y, Fs, nbits] = wavread(filename)
[y, Fs, nbits, opts] = wavread(filename)
[___] = wavread(filename, N)
[___] = wavread(filename, [N1 N2])
[___] = wavread(___, fmt)
siz = wavread(filename, 'size')
```

**Description** `y = wavread(filename)` loads a WAVE file specified by the string `filename`, returning the sampled data in `y`. If `filename` does not include an extension, `wavread` appends `.wav`.

`[y, Fs] = wavread(filename)` returns the sample rate (`Fs`) in Hertz used to encode the data in the file.

`[y, Fs, nbits] = wavread(filename)` returns the number of bits per sample (`nbits`).

`[y, Fs, nbits, opts] = wavread(filename)` returns a structure `opts` of additional information contained in the WAV file. The content of this structure differs from file to file. Typical structure fields include `opts.fmt` (audio format information) and `opts.info` (text that describes the title, author, etc.).

`[ ___ ] = wavread(filename, N)` returns only the first `N` samples from each channel in the file.

`[ ___ ] = wavread(filename, [N1 N2])` returns only samples `N1` through `N2` from each channel in the file.

[ \_\_\_ ] = wavread( \_\_\_, *fmt*) specifies the data format of *y* used to represent samples read from the file. *fmt* can be either of the following values, or a partial match (case-insensitive):

- 'double'      Double-precision normalized samples (default).
- 'native'      Samples in the native data type found in the file.

*siz* = wavread(*filename*, 'size') returns the size of the audio data contained in *filename* instead of the actual audio data, returning the vector *siz* = [*samples channels*].

## Output Scaling

The range of values in *y* depends on the data format *fmt* specified. Some examples of output scaling based on typical bit-widths found in a WAV file are given below for both 'double' and 'native' formats.

## Native Formats

Number of Bits	MATLAB Data Type	Data Range
8	uint8 (unsigned integer)	$0 \leq y \leq 255$
16	int16 (signed integer)	$-32768 \leq y \leq +32767$
24	int32 (signed integer)	$-2^{23} \leq y \leq 2^{23}-1$
32	single (floating point)	$-1.0 \leq y < +1.0$

**Double Formats**

Number of Bits	MATLAB Data Type	Data Range
N<32	double	-1.0 ≤ y < +1.0
N=32	double	-1.0 ≤ y ≤ +1.0 Note: Values in y might exceed -1.0 or +1.0 for the case of N=32 bit data samples stored in the WAV file.

wavread supports multi-channel data, with up to 32 bits per sample.

wavread supports Pulse-code Modulation (PCM) data format only.

**Examples**

Create a WAV file from the example file handel.mat, and read portions of the file back into MATLAB.

```
% Create WAV file in current folder.
load handel.mat

hfile = 'handel.wav';
wavwrite(y, Fs, hfile)
clear y Fs

% Read the data back into MATLAB, and listen to audio.
[y, Fs, nbits, readinfo] = wavread(hfile);
sound(y, Fs);

% Pause before next read and playback operation.
duration = numel(y) / Fs;
pause(duration + 2)

% Read and play only the first 2 seconds.
nsamples = 2 * Fs;
[y2, Fs] = wavread(hfile, nsamples);
```

# wavread

---

```
sound(y2, Fs);
pause(4)

% Read and play the middle third of the file.
sizeinfo = wavread(hfile, 'size');

tot_samples = sizeinfo(1);
startpos = tot_samples / 3;
endpos = 2 * startpos;

[y3, Fs] = wavread(hfile, [startpos endpos]);
sound(y3, Fs);
```

## See Also

```
mmfileinfo | audioinfo | audiowrite | audioread | audioplayer
| audiorecorder | sound
```

**Purpose** Record sound using PC-based audio input device

---

**Note** wavrecord has been removed. Use audiorecorder instead.

---

**Syntax**

```
y = wavrecord(n,Fs)
y = wavrecord(__ ,ch)
y = wavrecord(__ , 'dtype')
```

**Description** `y = wavrecord(n,Fs)` records `n` samples of an audio signal, sampled at a rate of `Fs` Hz (samples per second). The default value for `Fs` is 11025 Hz.

`y = wavrecord( __ ,ch)` uses `ch` number of input channels from the audio device. `ch` can be either 1 or 2, for mono or stereo, respectively. The default value for `ch` is 1.

`y = wavrecord( __ , 'dtype')` uses the data type specified by the string `'dtype'` to record the sound. The following table lists the string values for `'dtype'` along with the corresponding bits per sample and acceptable data range for `y`.

<b>dtype</b>	<b>Bits/sample</b>	<b>y Data Range</b>
'double'	16	$-1.0 \leq y < +1.0$
'single'	16	$-1.0 \leq y < +1.0$
'int16'	16	$-32768 \leq y \leq +32767$
'uint8'	8	$0 \leq y \leq 255$

**Tips** Standard sampling rates for PC-based audio hardware are 8000, 11025, 22050, and 44100 samples per second. Stereo signals are returned as two-column matrices. The first column of a stereo audio matrix corresponds to the left input channel, while the second column corresponds to the right input channel.

# wavrecord

---

The `wavrecord` function is for use only with 32-bit Microsoft Windows operating systems. To record audio data from audio input devices on other platforms, use `audiorecorder`.

## Examples

Record 5 seconds of 16-bit audio sampled at 11025 Hz. Play back the recorded sound using `wavplay`. Speak into your audio device (or produce your audio signal) while the `wavrecord` command runs.

```
Fs = 11025;
y = wavrecord(5*Fs,Fs,'int16');
wavplay(y,Fs);
```

## See Also

`audiorecorder` | `audioinfo` | `audioread` | `audiowrite`

**Purpose** Write WAVE (.wav) sound file

---

**Note** wavwrite will be removed in a future release. Use audiowrite instead.

---

**Syntax**

```
wavwrite(y, filename)
wavwrite(y, Fs, filename)
wavwrite(y, Fs, N, filename)
```

**Description** wavwrite(y, filename) writes the data stored in the variable *y* to a WAVE file called *filename*. The *filename* input is a string enclosed in single quotes. The data has a sample rate of 8000 Hz and is assumed to be 16-bit. Each column of the data represents a separate channel. Therefore, stereo data should be specified as a matrix with two columns.

wavwrite(y, Fs, filename) writes the data stored in the variable *y* to a WAVE file called *filename*. The data has a sample rate of *Fs* Hz and is assumed to be 16-bit.

wavwrite(y, Fs, N, filename) writes the data stored in the variable *y* to a WAVE file called *filename*. The data has a sample rate of *Fs* Hz and is *N*-bit, where *N* is 8, 16, 24, or 32.

### Input Data Ranges

The range of values in *y* depends on the number of bits specified by *N* and the data type of *y*. The following tables list the valid input ranges based on the value of *N* and the data type of *y*.

If *y* contains integer data:

N Bits	y Data Type	y Data Range	Output Format
8	uint8	$0 \leq y \leq 255$	uint8
16	int16	$-32768 \leq y \leq +32767$	int16
24	int32	$-2^{23} \leq y \leq 2^{23} - 1$	int32

If  $y$  contains floating-point data:

<b>N Bits</b>	<b>y Data Type</b>	<b>y Data Range</b>	<b>Output Format</b>
8	single or double	$-1.0 \leq y < +1.0$	uint8
16	single or double	$-1.0 \leq y < +1.0$	int16
24	single or double	$-1.0 \leq y < +1.0$	int32
32	single or double	$-1.0 \leq y \leq +1.0$	single

For floating point data where  $N < 32$ , amplitude values are clipped to the range  $-1.0 \leq y < +1.0$ .

---

**Note** 8-, 16-, and 24-bit files are type 1 integer pulse code modulation (PCM). 32-bit files are written as type 3 normalized floating point.

---

## See Also

`mmfileinfo` | `audioinfo` | `audioread` | `audiowrite` | `audioplayer`  
| `audiorecorder` | `sound`



**Purpose**

Open Web page or file in browser

**Syntax**

```
web
web(url)
web(url,opt)
web(url,opt1,...,optN)

stat = web(___)
[stat,h] = web(___)
[stat,h,url] = web(___)
```

**Description**

`web` opens an empty MATLAB Web browser.

`web(url)` opens the page specified by `url` in the MATLAB Web browser. If multiple browsers are open, the page displays in the one that was most recently used.

`web(url,opt)` opens the page using the specified browser option, such as `'-new'` to create a new browser instance or `'-browser'` to use the system browser.

`web(url,opt1,...,optN)` opens the page using one or more browser options.

`stat = web( ___ )` returns the status of the operation: 0 if successful, 1 or 2 if unsuccessful. You can include any of the input arguments in previous syntaxes.

`[stat,h] = web( ___ )` returns a handle to a MATLAB Web browser that allows you to close it using the command `close(h)`. If you do not specify any inputs to the `web` function, such as `[stat,h] = web`, then the handle corresponds to the most recently used MATLAB Web browser.

[stat,h,url] = web( \_\_\_ ) returns the URL of the current page in the MATLAB Web browser.

## Input Arguments

### url - Web page address or file location

string

Web page address or file location, specified as a string. File locations can include an absolute or relative path.

If url corresponds to a file in the installed product documentation, then the page displays in the MATLAB Help browser instead of the Web browser.

**Example:** 'http:\\www.mathworks.com'

**Example:** 'myfolder/myfile.html'

### opt - Browser option

'-browser' | '-new' | '-noaddressbox' | '-notoolbar'

Browser option, specified as one of the following strings. Options can appear in any order.

- '-browser' Opens the page in a system browser window instead of the MATLAB Web browser. On Microsoft Windows and Apple Macintosh platforms, the operating system determines the system Web browser. On other systems, the default is the Mozilla® Firefox® browser, but you can change the default using MATLAB Web preferences.
- '-new' Opens the page in a new MATLAB Web browser window. Does not apply to the system browser.

- '-noaddressbox' Opens the page in a browser that does not display the address box. Only applies to new instances of the MATLAB Web browser.
- '-notoolbar' Opens the page in a browser that does not display a toolbar or address box. Only applies to new instances of the MATLAB Web browser.

**Example:** '-new', '-noaddressbox'

## Output Arguments

### **stat - Browser status**

0 | 1 | 2

Browser status, returned as an integer with one of these values:

- 0 Found and launched system browser.
- 1 Could not find system browser.
- 2 Found, but could not launch system browser.

### **h - Handle to most recent MATLAB Web browser**

scalar

Handle to the most recent MATLAB Web browser, returned as a scalar instance of the associated Java class.

If you do not request the handle when you open the page, be aware that this handle might not correspond to your most recent use of the `web` function. Other MATLAB functionality also uses the `web` function, such as links to external sites from the Help browser.

### **url - Current page address**

string

Current page address in the most recent MATLAB Web browser, returned as a string.

## Examples

### Web Page in MATLAB Web Browser

Open the MathWorks Web site home page.

```
url = 'http://www.mathworks.com';
web(url)
```

Open the page in a new instance of the browser that does not include a toolbar.

```
web(url, '-new', '-notoolbar')
```

### File in MATLAB Web Browser

View an HTML file that resides on your system.

Create an HTML file by publishing an example program file. Copy the program file to the current folder so that the code can run during the publishing process.

```
program = fullfile(matlabroot, 'help', 'techdoc', ...
 'matlab_env', 'examples', 'fourier_demo2.m');
copyfile(program);
htmlFile = publish('fourier_demo2.m');
```

View a file by specifying the file name.

```
web(htmlFile)
```

Alternatively, you can use the `file:///` URL scheme, as long as you include the full path. The `publish` function returns the path in the `htmlFile` output.

```
url = ['file:///', htmlFile];
web(url)
```

### Web Page in System Browser

Open the MathWorks Web site home page in the system browser.

```
url = 'http://www.mathworks.com';
```

```
web(url, '-browser')
```

### Email from System Browser

Send email from your system browser's default mail application using the `mailto:` URL scheme.

To run this example, replace the value for `email` with a valid email address.

```
email = 'myaddress@provider.ext';
url = ['mailto:',email];
web(url)
```

### Handle to MATLAB Web Browser

Open the MathWorks Web site home page, and then close the browser using its handle.

```
url = 'http://www.mathworks.com';
[stat,h] = web(url);
```

Close the browser window.

```
close(h)
```

### Text Displayed in MATLAB Web Browser

View formatted text using the `text://` URL scheme.

```
web('text://<html><h1>Hello World</h1></html>')
```

## Tips

- If you plan to deploy an application that calls the `web` function using the MATLAB Compiler product, then use the `'-browser'` option.
- If you are displaying Japanese streaming text in the MATLAB Web browser, specify a header that includes the `charset` attribute. For example:

```
web(['text://<html><head><meta http-equiv="content-type" ' ...
 'content="text/html; charset=utf-8"></head><body>TEXT</body></html>'])
```

## See Also

`urlread` | `urlwrite`

## Concepts

- “Web Browsers and MATLAB”
- “Specify Proxy Server Settings for Connecting to the Internet”
- “Specify the System Browser for UNIX Platforms”

## Purpose

Day of week

## Syntax

```
DayNumber = weekday(D)
[DayNumber,DayName] = weekday(D)
[DayNumber,DayName] = weekday(D,DayForm)
[DayNumber,DayName] = weekday(D,language)
[DayNumber,DayName] = weekday(D,DayForm,language)
```

## Description

`DayNumber = weekday(D)` returns a number representing the day of the week for each element in `D`.

`[DayNumber,DayName] = weekday(D)` additionally returns abbreviated English names for the day of the week, in `DayName`.

`[DayNumber,DayName] = weekday(D,DayForm)` returns the name for the day of the week in the format specified by `DayForm`, in US English.

`[DayNumber,DayName] = weekday(D,language)` returns the abbreviated name for the day of the week in the language of the locale specified in `language`.

`[DayNumber,DayName] = weekday(D,DayForm,language)` returns the name for the day of the week in the specified format and in the language of the specified locale. You can specify `DayForm` and `language` in either order.

## Input Arguments

### **D - Serial date numbers or date strings**

vector | matrix | string | cell array of strings | character array

Serial date numbers or date strings. Date numbers can be specified as a vector or matrix. Date strings can be specified as a single string, a cell array of strings, or a character array. If `D` is a cell array of strings, it must be 1-by-`n` or `n`-by-1.

# weekday

---

If D is a single date string, a cell array of date strings, or a character array of date strings, the date strings can be in one of the following formats.

Date String Format	Example
dd-mmm-yyyy	01-Mar-2000
mm/dd/yyyy	03/01/2000
yyyy-mm-dd	2000-03-01

For date strings in other formats, first convert them to serial date numbers using the `datenum` function, before passing them to `weekday`.

## Data Types

single | double | int8 | int16 | int32 | int64 | uint8 | uint16 | uint32 | uint64 | char | cell

## DayForm - Format of output day names

'short' (default) | 'long'

Format of the output day names, specified as one of the following strings.

DayForm	Format of DayName Names	Example
'short'	Abbreviated name	Mon
'long'	Full name	Monday

## language - Output language of day names

'en\_US' (default) | 'local'

Output language of day names in `DayName`, specified as one of the following strings.



language	Description
'en_US'	US English
'local'	Language of the current locale

## Output Arguments

### DayNumber - Value representing day of week

array of integers in the range [1,7]

Value representing the day of the week, returned as an array of integers in the range [1,7], where 1 represents Sunday, and 7 represents Saturday.

- If input D is a numeric array, then the size of DayNumber is equivalent to the size of D.
- If input D is a cell array of strings, then DayNumber is an m-by-1 vector, where m is equivalent to the length of D.

### DayName - Name of day of week

character array

Name of the day of the week, returned as a character array. The content of DayName depends on DayForm.

- If DayForm is 'short', then DayName contains an abbreviated name (for example, Tues).
- If DayForm is 'long', then DayName contains the full name of the weekday (for example, Tuesday).

DayName is m-by-n, where m is the number of serial date numbers or date strings in D.

## Examples

### Return Day of Week of a Date String

Determine the day of the week of December 21, 2012.

```
D = '21-Dec-2012';
[DayNumber,DayName] = weekday(D)
```

# weekday

---

```
DayNumber =
```

```
 6
```

```
DayName =
```

```
Fri
```

December 21, 2012 falls on a Friday.

## **Return Full Day Names of Multiple Date Numbers**

Return the full name of the day of the week for a vector of serial date numbers.

```
D = [734999;735015];
DayForm = 'long';
[DayNumber,DayName] = weekday(D,DayForm)
```

```
DayNumber =
```

```
 5
```

```
 7
```

```
DayName =
```

```
Thursday
```

```
Saturday
```

## **Return Full Day Names in Local Language**

Return day names in U.S. English using the language input argument.

```
D = 728647;
DayForm = 'long';
language = 'en_US';
```

```
[DayNumber, DayName] = weekday(D, DayForm, language)
```

```
DayNumber =
```

```
2
```

```
DayName =
```

```
Monday
```

In U.S. English, the name of the day of the week is Monday.

Return day names in the language of the current locale.

```
language = 'local';
```

```
[DayNumber, DayName] = weekday(D, DayForm, language)
```

```
DayNumber =
```

```
2
```

```
DayName =
```

```
Lundi
```

In a French locale, the name of the day of the week is Lundi.

## **Return Day of Week of a Date String in Custom Format**

Determine the day of the week for a date specified in the format `mmm.dd.yyyy`. Call `datenum` inside of `weekday` to specify the format of the input date string.

```
[DayNumber, DayName] = weekday(datenum('Dec.21.2012', 'mmm.dd.yyyy'))
```

```
DayNumber =
```

# weekday

---

6

DayName =

Fri

## See Also

[datenum](#) | [datevec](#) | [eomday](#)

**Purpose** List MATLAB files in folder

**Syntax**

```

what
what folderName
what className
what packageName
s = what(' folderName ')

```

**Description**

what lists the path for the current folder, and lists all files and folders relevant to MATLAB found in the current folder. Files listed are M, MAT, MEX, MDL, SLX, and P-files. Folders listed are all class and package folders.

what *folderName* lists path, file, and folder information for *folderName*.

what *className* lists path, file, and folder information for method folder *@className*. For example, what cfit lists the MATLAB files and folders in toolbox/curvefit/curvefit/@cfit.

what *packageName* lists path, file, and folder information for package folder *+packageName*. For example, what commsrc lists the MATLAB files and folders in toolbox/comm/comm/+commsrc.

s = what(' *folderName* ') returns the results in a structure array with the fields shown in the following table.

Field	Description
path	Path to folder
m	Cell array of MATLAB program file names
mat	Cell array of MAT-file names
mex	Cell array of MEX-file names
mdl	Cell array of MDL-file names
slx	Cell array of SLX-file names
p	Cell array of P-file names

# what

Field	Description
classes	Cell array of class folders
packages	Cell array of package folders

## Examples

List the MATLAB files and folders in C:\Program Files\MATLAB\Rnnnn\toolbox\matlab\audiovideo\+audiovideo, where *Rnnnn* represents the folder for the MATLAB release, for example, R2012b:

```
what audiovideo

MATLAB Code files in folder C:\Program Files\MATLAB\Rnnnn\toolbox\matlab\audiovideo\+audiovideo

FileFormatInfo

Packages in folder C:\Program Files\MATLAB\Rnnnn\toolbox\matlab\audiovideo\+audiovideo

internal writer

MATLAB Code files in folder C:\Program Files\MATLAB\Rnnnn\toolbox\matlab\audiovideo

Contents auinfo mmcompinfo wavplay
audiodevinfo auread mmfileinfo wavread
audioinfo auwrite movie2avi wavrecord
audioplayerreg avgate mu2lin wavwrite
audioread avifinfo prefspanel
audiorecorderreg aviinfo sound
audiouniquename aviread soundsc
audiowrite lin2mu wavfinfo

MAT-files in folder C:\Program Files\MATLAB\Rnnnn\toolbox\matlab\audiovideo

chirp handel splat
gong laughter train
```

Classes in folder C:\Program Files\MATLAB\Rnnnn\toolbox\matlab\audiovideo

```
VideoReader audioplayer avifile
VideoWriter audiorecorder mmreader
```

Packages in folder C:\Program Files\MATLAB\Rnnnn\toolbox\matlab\audiovideo

```
audiovideo
```

---

Obtain a structure array containing the file and folder names in `toolbox/matlab/codetools` that are relevant to MATLAB, where *Rnnnn* represents the folder for the MATLAB release, for example, R2012a:

```
s = what('codetools')
```

```
s =
```

```
 path: 'C:\Program Files\MATLAB\Rnnnn\toolbox\matlab\codetools'
 m: {77x1 cell}
 mat: {0x1 cell}
 mex: {0x1 cell}
 mdl: {0x1 cell}
 slx: {0x1 cell}
 p: {0x1 cell}
 classes: {2x1 cell}
 packages: {3x1 cell}
```

---

Find the supporting files for one of the packages in the Communications System Toolbox product:

```
p1 = what('comm');
p1.packages
ans =
```

# what

---

```
'gpu'
'internal'

ans =

 'internal'.
.
.
p2 = what('commsrc');
p2.m
ans =
 'abstractJitter.m'
 'abstractPulse.m'
 'combinedjitter.m'
 'diracjitter.m'
 'periodicjitter.m'
 'randomjitter.m'
```

## See Also

[dir](#) | [exist](#) | [lookfor](#) | [ls](#) | [which](#) | [who](#)



**Purpose** Release Notes

---

**Note** whatsnew will be removed in a future release.

---

**Syntax** whatsnew

**Description** whatsnew displays the MATLAB Release Notes in the Help browser, presenting information about new features, problems from previous releases that have been fixed in the current release, and compatibility issues.

**See Also** help | version

# which

---

**Purpose** Locate functions and files

**Syntax**

```
which item
which fun1 in fun2

which ___ -all

str = which(item)
str = which(fun1,'in',fun2)

str = which(___, '-all')
```

**Description** `which item` displays the full path for `item`.

- If `item` is a MATLAB function in an M or P file, or a Simulink model in an SLX or MDL file, then `which` displays the full path for the corresponding file. `item` must be on the MATLAB path.
- If `item` is a method in a loaded Java class, then `which` displays the package, class, and method name for that method.
- If `item` is a workspace variable, then `which` displays a message identifying `item` as a variable.
- If `item` is a file name including the extension, and it is in the current working folder or on the MATLAB path. then `which` displays the full path of `item`.

If `item` is an overloaded function or method, then `which item` returns only the path of the first function or method found.

`which fun1 in fun2` displays the path to function `fun1` that is called by file `fun2`. Use this syntax to determine whether a local function is being called instead of a function on the path. This syntax does not locate nested functions.

`which ___ -all` displays the paths to all items on the MATLAB path with the requested name. Such items include methods of instantiated

classes. You can use `-all` with the input arguments of any of the previous syntaxes.

`str = which(item)` returns the full path for `item` in the string, `str`.

`str = which(fun1, 'in', fun2)` returns the path to function `fun1` that is called by file `fun2`. Use this syntax to determine whether a local function is being called instead of a function on the path. This syntax does not locate nested functions.

`str = which(___, '-all')` returns the results of `which` in the string or cell array of strings, `str`. You can use this syntax with any of the input arguments in the previous syntax group.

## Input Arguments

### **item - Function or file to locate**

string

Function or file to locate, specified as a string. When using the function form of `which`, enclose all input strings in single quotes. `item` can be in one of the following forms.

Form of the <code>item</code> Input	Path to Display
<code>fun</code>	Display full path for <code>fun</code> , which can be a MATLAB function, Simulink model,
<code>private/fun</code>	Limit the search to private functions named <code>fun</code> . For example, <code>which private/orthog</code> or <code>which('private/orthog')</code> displays the path for <code>orthog.m</code> in the <code>/private</code> subfolder of the parent folder.
<code>fun(a1, ..., an)</code>	Display the path to the implementation of function <code>fun</code> which would be invoked if called with the input arguments <code>a1, ..., an</code> . Use this syntax to query overloaded functions. See the Example, "Locate Function Invoked with Given Input Arguments" on page 1-7700.

## **fun1 - Function to locate**

string

Function to locate, specified as a string. `fun1` can be the name of a function, or it can be in the form `fun(a1,...,an)`. For more information about the form, `fun(a1,...,an)`, see “Locate Function Invoked with Given Input Arguments” on page 1-7700.

When using the function form of `which`, enclose all input strings in single quotes, for example, `which('myfun1','in','myfun2')`.

## **fun2 - Calling file**

string

Calling file, specified as a string. `fun2` can be the name of a file, or it can be in the form `fun(a1,...,an)`. For more information about the form, `fun(a1,...,an)`, see “Locate Function Invoked with Given Input Arguments” on page 1-7700.

When using the function form of `which`, enclose all input strings in single quotes, for example, `which('myfun1','in','myfun2')`.

## **Output Arguments**

### **str - Function or file location**

string | cell array of strings

Function or file location, returned as a string, or returned as a cell array of strings if you use `'-all'`.

- If `item` is a workspace variable, then `str` is the string `'variable'`.
- If `str` is a cell array of strings, then each row of `str` identifies a function, and the functions are in order of precedence.

## **Examples**

### **Locate MATLAB Function**

Locate the `pinv` function.

```
which pinv
```

```
matlabroot\toolbox\matlab\matfun\pinv.m
```

`pinv` is in the `matfun` folder of MATLAB.

You also can use function syntax to return the path to a string, `str`. When using the function form of `which`, enclose all input strings in single quotes.

```
str = which('pinv');
```

### **Locate Method in a Loaded Java Class**

Create an instance of the Java class. This loads the class into MATLAB.

```
myDate = java.util.Date;
```

Locate the `setMonth` method.

```
which setMonth
```

```
setMonth is a Java method % java.util.Date method
```

### **Locate Private Function**

Find the `orthog` function in a private folder.

```
which private/orthog
```

```
matlabroot\toolbox\matlab\elmat\private\orthog.m
% Private to elmat
```

MATLAB displays the path for `orthog.m` in the `/private` subfolder of `toolbox/matlab/elmat`.

### **Determine if Local Function is Called**

Determine which `parseargs` function is called by `area.m`.

```
which parseargs in area
```

```
matlabroot\toolbox\matlab\specgraph\area.m (parseargs)
% Subfunction of area
```

# which

---

You also can use function syntax to return the path to a string, `str`. When using the function form of `which`, enclose all input strings in single quotes.

```
str = which('parseargs','in','area');
```

## Locate Function Invoked with Given Input Arguments

Suppose you have a `matlab.io.MatFile` object that corresponds to the example MAT-file 'topography.mat':

```
matObj = matfile('topography.mat');
```

Display the path of the implementation of `who` that is invoked when called with the input argument (`matObj`).

```
which who(matObj)
```

```
matlabroot\toolbox\matlab\iofun\+matlab\+io\MatFile.m
% matlab.io.MatFile method
```

Store the result to a string.

```
str = which('who(matObj)')
```

```
str =
matlabroot\toolbox\matlab\iofun\+matlab\+io\MatFile.m
```

If you do not specify the input argument (`matObj`), then `which` returns only the path of the first function or method found.

```
which who
```

```
built-in (matlabroot\\toolbox\matlab\general\who)
```

## Locate All Items with Given Name

Display the paths to all items on the MATLAB path with the name `fopen`.

```
which fopen -all
```

```

built-in (matlabroot\toolbox\matlab\iofun\ fopen)
matlabroot\toolbox\matlab\iofun\@serial\ fopen.m % serial me
matlabroot\toolbox\shared\instrument\@icinterface\ fopen.m % icinterfa
matlabroot\toolbox\instrument\instrument\@i2c\ fopen.m
% i2c method

```

## Return Path Names as Strings

Return the results of `which` in the string `str`.

You must use the function form of `which`, enclosing all arguments in parentheses and single quotes.

```

str = which('private/stradd', '-all');
whos str

```

Name	Size	Bytes	Class	Attributes
str	2x1	650	cell	

## Tips

- For more information about how MATLAB uses scope and precedence when calling a function, see “Function Precedence Order”.

## Limitations

- When the class is not loaded, `which` only finds methods if they are defined in separate files in an `@`-folder and are not in any packages.

## See Also

`dir` | `doc` | `exist` | `lookfor` | `mfilename` | `path` | `type` | `what` | `who` | `fileparts` |

# while

---

**Purpose** Repeatedly execute statements while condition is true

**Syntax** `while expression`  
`statements`  
`end`

**Description** `while expression, statements, end` repeatedly executes one or more MATLAB program *statements* in a loop as long as an expression remains true.

An evaluated expression is true when the result is nonempty and contains all nonzero elements (logical or real numeric). Otherwise, the expression is false.

Expressions can include relational operators (such as `<` or `==`) and logical operators (such as `&&`, `||`, or `~`). MATLAB evaluates compound expressions from left to right, adhering to operator precedence rules.

---

**Note** Within the condition *expression* of an `if` or `while` statement, logical operators `&` and `|` behave as short-circuit operators. This behavior is the same as `&&` and `||`, respectively. Since `&&` and `||` consistently short-circuit in `if` and `while` condition expressions and statements, it is good practice to use `&&` and `||` instead of `&` and `|` within *expression*.

---

## Tips

- If you inadvertently create an infinite loop (that is, a loop that never ends on its own), stop execution of the loop by pressing **Ctrl+C**.
- To programmatically exit the loop, use a `break` statement. To skip the rest of the instructions in the loop and begin the next iteration, use a `continue` statement.
- You can nest any number of `while` statements. Each `while` statement requires an end keyword.



**Examples**

Find the first integer  $n$  for which `factorial(n)` is a 100-digit number.

```
n = 1;
nFactorial = 1;
while nFactorial < 1e100
 n = n + 1;
 nFactorial = nFactorial * n;
end
```

---

Count the number of lines of code in the file `magic.m`, skipping all blank lines and comments.

```
fid = fopen('magic.m','r');
count = 0;
while ~feof(fid)
 line = fgetl(fid);
 if isempty(line) || strncmp(line,'% ',1) || ~ischar(line)
 continue
 end
 count = count + 1;
end
fprintf('%d lines\n',count);
fclose(fid);
```

---

Find the root of the polynomial  $x^3 - 2x - 5$  using interval bisection.

```
a = 0; fa = -Inf;
b = 3; fb = Inf;
while b-a > eps*b
 x = (a+b)/2;
 fx = x^3-2*x-5;
 if fx == 0
 break
 elseif sign(fx) == sign(fa)
 a = x; fa = fx;
 end
end
```

# while

---

```
 else
 b = x; fb = fx;
 end
end
disp(x)
```

---

Take advantage of short-circuiting to avoid error or warning messages.

```
x = 42;
while exist('myfunction.m') && (myfunction(x) >= pi)
 disp('Condition is true')
 break
end
```

## See Also

return | continue | break | for | end | if | switch | Logical Operators: Short Circuit

## Concepts

- “Relational Operators”

---

<b>Purpose</b>	Change axes background color
<b>Syntax</b>	<pre>whitebg whitebg(fig) whitebg(ColorSpec) whitebg(fig, ColorSpec) whitebg(fig, ColorSpec) whitebg(fig)</pre>
<b>Description</b>	<p><code>whitebg</code> complements the colors in the current figure.</p> <p><code>whitebg(fig)</code> complements colors in all figures specified in the vector <code>fig</code>.</p> <p><code>whitebg(ColorSpec)</code> and <code>whitebg(fig, ColorSpec)</code> change the color of the axes, which are children of the figure, to the color specified by <code>ColorSpec</code>. Without a figure specification, <code>whitebg</code> or <code>whitebg(ColorSpec)</code> affects the current figure and the root's default properties so subsequent plots and new figures use the new colors.</p> <p><code>whitebg(fig, ColorSpec)</code> sets the default axes background color of the figures in the vector <code>fig</code> to the color specified by <code>ColorSpec</code>. Other axes properties and the figure background color can change as well so that graphs maintain adequate contrast. <code>ColorSpec</code> can be a 1-by-3 RGB color or a color string such as 'white' or 'w'.</p> <p><code>whitebg(fig)</code> complements the colors of the objects in the specified figures. This syntax is typically used to toggle between black and white axes background colors, and is where <code>whitebg</code> gets its name. Include the root window handle (0) in <code>fig</code> to affect the default properties for new windows or for <code>clf reset</code>.</p>
<b>Tips</b>	<p><code>whitebg</code> works best in cases where all the axes in the figure have the same background color.</p> <p><code>whitebg</code> changes the colors of the figure's children, with the exception of shaded surfaces. This ensures that all objects are visible against the new background color. <code>whitebg</code> sets the default properties on the root such that all subsequent figures use the new background color.</p>

# whitebg

---

## Examples

Set the background color to blue-gray.

```
whitebg([0 .5 .6])
```

Set the background color to blue.

```
whitebg('blue')
```

## See Also

[ColorSpec](#) | [colordef](#)

**Purpose**

List variables in workspace

**Syntax**

```
who
who(variables)
who(location)
who(variables,location)
c = who(variables,location)
```

**Description**

`who` lists in alphabetical order all variables in the currently active workspace.

`who(variables)` lists only the specified variables.

`who(location)` lists variables in the specified location: 'global' for the global workspace, or '-file' for a MAT-file. For MAT-files, you must also include the file name as an input.

`who(variables,location)` lists the specified variables in the specified location. The `location` input can appear before or after `variables`.

`c = who(variables,location)` stores the names of the variables in cell array `c`. Specifying `variables` and `location` is optional.

**Tips**

- The `who` function displays the variable list unless you specify an output argument.
- When used within a nested function, the `who` function lists the variables in the workspaces of that function and all functions containing that function, grouped by workspace. This applies whether you call `who` from your function code or from the MATLAB debugger.

**Input Arguments****variables**

Strings that specify the variables to list. Use one of these forms:

# who

---

*var1, var2, ...*

List the specified variables. Use the '\*' wildcard to match patterns. For example, `who('A*')` lists all variables that start with A.

'-regexp', *expressions*

List variables whose names match the specified regular expressions.

**Default:** '\*' (all variables)

## location

String that indicates whether to list variables from the global workspace or from a file:

'global'

Global workspace.

'-file', *filename*

MAT-file. The *filename* input can include the full, relative, or partial path.

**Default:** '' (current workspace)

## Output Arguments

**c**

Cell array of strings that correspond to each variable name.

## Examples

Display information about variables in the current workspace whose names start with the letter a:

```
who a*
```

---

Show variables stored in MAT-file `durer.mat`:

```
who -file durer
```

This code returns:

Your variables are:

```
X caption map
```

---

Store the variable names from `durer.mat` in cell array `durerInfo`:

```
durerInfo = who('-file', 'durer');
```

Display the contents of cell array `durerInfo`:

```
for k=1:length(durerInfo)
 disp(durerInfo{k})
end
```

This code returns:

```
X
 caption
 map
```

---

Suppose that a file `mydata.mat` contains variables with names that start with `java` and end with `Array`. Display information about those variables:

```
whos -file mydata -regexp \<java.*Array\>
```

---

Call `who` within a nested function (`get_date`):

```
function who_demo
date_time = datestr(now);

[str pos] = textscan(date_time, '%S%S%S', ...
 1, 'delimiter', '- :');
```

# who

---

```
get_date(str);

function get_date(d)
 day = d{1};
 mon = d{2};
 year = d{3};
 who
end

end
```

When you run `who_demo`, the `who` function displays the variables by function workspace (although the name of the function does not appear in the output):

Your variables are:

```
d mon ans pos
day year date_time str
```

## Alternatives

To view the variables in the workspace, use the Workspace browser. To view the contents of MAT-files, use the Details Panel of the Current Folder browser..

## See Also

`assignin` | `clear` | `dir` | `evalin` | `exist` | `inmem` | `load` | `save` | `what` | `whos` | `workspace`



<b>Purpose</b>	Names of variables in MAT-file				
<b>Syntax</b>	<pre>varlist = who(matObj) varlist = who(matObj,variables)</pre>				
<b>Description</b>	<p><code>varlist = who(matObj)</code> lists alphabetically all variables in the MAT-file associated with <code>matObj</code>. Optionally, returns the list in cell array <code>varlist</code>.</p> <p><code>varlist = who(matObj,variables)</code> lists the specified variables.</p>				
<b>Input Arguments</b>	<p><b>matObj</b> Object created by the <code>matfile</code> function.</p> <p><b>variables</b> Names of variables in the MAT-file corresponding to <code>matObj</code>. Use one of these forms:</p> <table><tr><td><code>var1,...,varN</code></td><td>Comma-separated list of variable name strings. Optionally, match patterns with the '*' wildcard, such as <code>who(matobj,'A*')</code>.</td></tr><tr><td><code>'-regexp',expressions</code></td><td>Regular expression strings that describe variable names.</td></tr></table>	<code>var1,...,varN</code>	Comma-separated list of variable name strings. Optionally, match patterns with the '*' wildcard, such as <code>who(matobj,'A*')</code> .	<code>'-regexp',expressions</code>	Regular expression strings that describe variable names.
<code>var1,...,varN</code>	Comma-separated list of variable name strings. Optionally, match patterns with the '*' wildcard, such as <code>who(matobj,'A*')</code> .				
<code>'-regexp',expressions</code>	Regular expression strings that describe variable names.				
<b>Output Arguments</b>	<p><b>varlist</b> Cell array of strings that correspond to each variable name.</p>				
<b>Examples</b>	<p>Display a list of variables in the example file <code>topography.mat</code>:</p> <pre>matObj = matfile('topography.mat'); who(matObj)</pre> <p>This code returns:</p>				

Your variables are:

topo          toplegend    topomap1    topomap2

## See Also

[matfile](#) | [whos](#)

**Purpose**

List variables in workspace, with sizes and types

**Syntax**

```
whos
whos(variables)
whos(location)
whos(variables,location)
```

```
S = whos(__)
```

**Description**

whos displays in alphabetical order all variables in the currently active workspace, with information about their sizes and types.

whos(variables) displays only the specified variables.

whos(location) displays variables in the specified location.

whos(variables,location) displays the specified variables in the specified location. The location and variables inputs can appear in either order.

S = whos( \_\_ ) stores information about the variables in structure array, S, using no input arguments, or any of the input arguments from the previous syntaxes.

**Input Arguments****variables - Variables to display**

strings

Variables to display, specified as one or more strings in one of the following forms.

# whos

Form of Variables Input	Variable Names
<code>var1 ... varN</code>	List the named variables, specified as individual strings. Use the '*' wildcard to match patterns. For example, <code>whos('A*')</code> lists all variables in the workspace that start with A.
<code>'-regexp',expr1 ... exprN</code>	List only the variables that match the regular expressions, specified as strings. For example, <code>whos('-regexp','^Mon','^Tues')</code> lists only the variables in the workspace that begin with Mon or Tues.

## location - Location of variables

`'global' | 'file',filename`

Location of variables, specified as one of the following strings.

Value of location	Location of Variables
<code>'global'</code>	Global workspace.
<code>'-file',filename</code>	MAT-file. The <i>filename</i> input can include the full, relative, or partial path. For example, <code>whos('file','myFile.mat')</code> lists all variables in the MAT-file named <i>myFile.mat</i> .  <code>whos('-file',filename)</code> does not return the sizes of any MATLAB objects in file <i>filename</i> .

## Output Arguments

### S - Information about variables

nested structure array

Information about variables, returned as a nested structure array that contains a scalar struct for each variable. Each scalar struct contains these fields.

Field	Description
name	Name of the variable.
size	Dimensions of the variable array.
bytes	Number of bytes allocated for the variable array.
class	Class of the variable. If the variable has no value, class is '(unassigned)'.
global	True if the variable is global; otherwise, false.
sparse	True if the variable is sparse; otherwise, false.
complex	True if the variable is complex; otherwise, false.
nesting	Structure with these fields: <ul style="list-style-type: none"> <li>function — Name of the nested or outer function that defines the variable.</li> <li>level — Nesting level of that function.</li> </ul>
persistent	True if the variable is persistent; otherwise, false.

## Examples

### Display Information About Workspace Variables

Display information about variables in the current workspace whose names start with the letter a.

```
whos('a*')
```

### Display Variables Stored in a MAT-File

Display all variables stored in the MAT-file, `durer.mat`.

```
whos('-file','durer.mat')
```

Name	Size	Bytes	Class	Attributes
X	648x509	2638656	double	
caption	2x28	112	char	
map	128x3	3072	double	

Show only variables in the MAT-file with names that end with ion.

```
whos('-file','durer.mat','-regexp','ion$')
```

Name	Size	Bytes	Class	Attributes
caption	2x28	112	char	

## Store Variable Information in a Structure Array

Store information about the variables in `durer.mat` in structure array `S`.

```
S = whos('-file','durer.mat');
```

Display the contents of `S`.

```
for k = 1:length(S)
 disp([' ' S(k).name ...
 ' ' mat2str(S(k).size) ...
 ' ' S(k).class]);
end
```

```
X [648 509] double
caption [2 28] char
map [128 3] double
```

## Create Function to Display Variable Attribute Information

In the Editor, create a function that creates variables with various persistent, global, sparse, and complex attributes, and then displays information about them.

```
function show_attributes
persistent p;
global g;
p = 1;
g = 2;
s = sparse(eye(5));
c = [4+5i 9-3i 7+6i];
whos
```

When you call the function, `show_attributes` displays the attributes.

```
show_attributes
```

Name	Size	Bytes	Class	Attributes
c	1x3	48	double	complex
g	1x1	8	double	global
p	1x1	8	double	persistent
s	5x5	128	double	sparse

### Call whos Within a Nested or Anonymous Function

Create a function, `whos_demo`, that contains a nested function, `get_date`. Call `whos` within the nested function.

```
function whos_demo
date_time = datestr(now);

C = strsplit(date_time,{'-',' '});
get_date(C);

 function get_date(d)
 day = d{1};
 mon = d{2};
 year = d{3};
 whos
 end
```

# whos

---

```
end
```

When you run the `whos_demo` function, `whos` displays the variables of the nested `get_date` function, and all functions that contain it, grouped by function workspace. This applies whether you call `whos` from your function code or from the MATLAB debugger.

```
whos_demo
```

Name	Size	Bytes	Class	Attributes
---- get_date -----				
d	1x3	372	cell	
day	1x2	4	char	
mon	1x3	6	char	
year	1x13	26	char	
---- whos_demo -----				
C	1x3	372	cell	
ans	0x0	0	(unassigned)	
date_time	1x20	40	char	

When called within an anonymous function, variables in the anonymous function also display in a group, titled with the function's signature

## Tips

- You also can view the contents of MAT-files using the Details Panel of the Current Folder browser.

## Algorithms

`whos` returns the number of bytes each variable occupies in the workspace, not in a MAT-file. Version 7 MAT-files and later are compressed, so the number of bytes in the file is typically fewer than the number of bytes required in the workspace.

## See Also

`clear` | `exist` | `what` | `who`

## Concepts

- “What Is the MATLAB Workspace?”



<b>Purpose</b>	Names, sizes, and types of variables in MAT-file				
<b>Syntax</b>	<pre>details = whos(matObj) details = whos(matObj,variables)</pre>				
<b>Description</b>	<p><code>details = whos(matObj)</code> returns information about all variables in the MAT-file associated with <code>matObj</code>.</p> <p><code>details = whos(matObj,variables)</code> returns information about the specified variables.</p>				
<b>Input Arguments</b>	<p><b>matObj</b> Object created by the <code>matfile</code> function.</p> <p><b>variables</b> Names of variables in the MAT-file corresponding to <code>matObj</code>. Use one of these forms:</p> <table border="0" style="margin-left: 40px;"> <tr> <td style="padding-right: 20px;"><code>var1,...,varN</code></td> <td>Comma-separated list of variable name strings. Optionally, match patterns with the '*' wildcard, such as <code>whos(matobj, 'A*')</code>.</td> </tr> <tr> <td style="padding-right: 20px;"><code>'-regex',expressions</code></td> <td>Regular expression strings that describe variable names.</td> </tr> </table>	<code>var1,...,varN</code>	Comma-separated list of variable name strings. Optionally, match patterns with the '*' wildcard, such as <code>whos(matobj, 'A*')</code> .	<code>'-regex',expressions</code>	Regular expression strings that describe variable names.
<code>var1,...,varN</code>	Comma-separated list of variable name strings. Optionally, match patterns with the '*' wildcard, such as <code>whos(matobj, 'A*')</code> .				
<code>'-regex',expressions</code>	Regular expression strings that describe variable names.				
<b>Output Arguments</b>	<p><b>details</b> Structure array with these fields (identical to the structure returned by the <code>whos</code> function):</p> <table border="0" style="margin-left: 40px;"> <tr> <td style="padding-right: 40px;"><code>name</code></td> <td>Variable name</td> </tr> <tr> <td style="padding-right: 40px;"><code>size</code></td> <td>Dimensions of the variable</td> </tr> </table>	<code>name</code>	Variable name	<code>size</code>	Dimensions of the variable
<code>name</code>	Variable name				
<code>size</code>	Dimensions of the variable				

bytes	Number of bytes allocated for the array when you load the entire variable
class	Class (data type) of the variable
global	Whether the variable is global (true or false)
sparse	Whether the variable is sparse
complex	Whether the variable is complex
nesting	Structure with these fields: <ul style="list-style-type: none"><li>• <code>function</code> — Name of the nested or outer function that defines the variable</li><li>• <code>level</code> — Nesting level</li></ul>
persistent	Whether the variable is persistent

## Examples

Display a list of variables in the example file `topography.mat`:

```
matObj = matfile('topography.mat');
whos(matObj)
```

This code returns:

Name	Size	Bytes	Class	Attributes
topo	180x360	518400	double	
topolegend	1x3	24	double	
topomap1	64x3	1536	double	
topomap2	128x3	3072	double	

---

Without loading any data, find the size and number of dimensions of the variable `topo` in `topography.mat`:

```
matObj = matfile('topography.mat');
info = whos(matObj, 'topo');
```

```
sizeX = info.size
nDimsX = length(sizeX)
```

This code returns:

```
sizeX =
 180 360

nDimsX =
 2
```

## See Also

[matfile](#) | [size](#)

# width

---

**Purpose** Number of table variables

**Syntax** `W = width(T)`

**Description** `W = width(T)` returns the number of variables in table T.  
`width(T)` is equivalent to `size(T,2)`.

**Input Arguments** **T - Input table**  
table

Input table, specified as a table.

Variables in a table can have multiple columns, but `width(T)` only counts the number of variables.

## **Examples** **Number of Variables in Table**

Create a table, T.

```
LastName = {'Smith';'Johnson';'Williams';'Jones';'Brown'};
Age = [38;43;38;40;49];
Height = [71;69;64;67;64];
Weight = [176;163;131;133;119];
BloodPressure = [124 93; 109 77; 125 83; 117 75; 122 80];
```

```
T = table(Age,Height,Weight,BloodPressure,'RowNames',LastName)
```

```
T =
```

	Age	Height	Weight	BloodPressure	
	—	—	—	—	
Smith	38	71	176	124	93
Johnson	43	69	163	109	77
Williams	38	64	131	125	83
Jones	40	67	133	117	75
Brown	49	64	119	122	80

Find the number of variables in table T.

```
W = width(T)
```

```
W =
```

```
 4
```

T contains 4 variables; width does not count the row names.

The variable BloodPressure counts as one variable even though it contains two columns.

## See Also

```
height | size | numel
```

# wilkinson

---

**Purpose** Wilkinson's eigenvalue test matrix

**Syntax** `W = wilkinson(n)`

**Description** `W = wilkinson(n)` returns one of J. H. Wilkinson's eigenvalue test matrices. It is a symmetric, tridiagonal matrix with pairs of nearly, but not exactly, equal eigenvalues.

**Examples** `wilkinson(7)`

`ans =`

```
 3 1 0 0 0 0 0
 1 2 1 0 0 0 0
 0 1 1 1 0 0 0
 0 0 1 0 1 0 0
 0 0 0 1 1 1 0
 0 0 0 0 1 2 1
 0 0 0 0 0 1 3
```

The most frequently used case is `wilkinson(21)`. Its two largest eigenvalues are both about 10.746; they agree to 14, but not to 15, decimal places.

**See Also** `eig` | `gallery` | `pascal`

**Purpose** Open file in appropriate application (Windows)

**Syntax** `winopen(fileName)`

**Description** `winopen(fileName)` opens `fileName` in the associated Microsoft Windows application. The application is associated with the extension in `fileName` in the Windows operating system. `filename` is a string enclosed in single quotes. `winopen` uses a Windows shell command, and performs the same action as double-clicking the file in the Windows Explorer program. That is, `winopen` calls the application associated with the file extension to open the file. Use an absolute or relative path for `fileName`.

**Examples** Open the file `thesis.doc`, located in the current folder, in the Microsoft Word program:

```
winopen('thesis.doc')
```

---

Open `myresults.html` in the system Web browser:

```
winopen('D:/myfiles/myresults.html')
```

---

On Microsoft Windows platforms, open the current folder in the Windows Explorer tool:

```
winopen(cd)
```

---

To open a file on the MATLAB path, use `winopen` with `which`. For example, to open the `meshgrid` function in the Editor, use:

```
winopen(which('meshgrid'))
```

**See Also** `dos` | `open` | `web`

# winqueryreg

---

**Purpose** Item from Windows registry

**Syntax**

```
valnames = winqueryreg('name', 'rootkey', 'subkey')
value = winqueryreg('rootkey', 'subkey', 'valname')
value = winqueryreg('rootkey', 'subkey')
```

**Description** `valnames = winqueryreg('name', 'rootkey', 'subkey')` returns all value names in `rootkey\subkey` of Microsoft Windows operating system registry to a cell array of strings. The first argument is the literal quoted string, 'name'.

`value = winqueryreg('rootkey', 'subkey', 'valname')` returns the value for value name `valname` in `rootkey\subkey`.

If the value retrieved from the registry is a string, `winqueryreg` returns a string. If the value is a 32-bit integer, `winqueryreg` returns the value as an integer of the MATLAB software type `int32`.

`value = winqueryreg('rootkey', 'subkey')` returns a value in `rootkey\subkey` that has no value name property.

---

**Note** The literal **name** argument and the `rootkey` argument are case-sensitive. The `subkey` and `valname` arguments are not.

---

**Tips** This function works only for the following registry value types:

- strings (REG\_SZ)
- expanded strings (REG\_EXPAND\_SZ)
- 32-bit integer (REG\_DWORD)

**Examples** **Example 1**

Get the value of CLSID for the MATLAB sample Microsoft COM control `mwsampctrl.2`:

```
winqueryreg 'HKEY_CLASSES_ROOT' 'mwsamp.mwsampctrl.2\clsid'
```



```
ans =
 {5771A80A-2294-4CAC-A75B-157DCDDD3653}
```

## Example 2

Get a list in variable `mousechar` for registry subkey `Mouse`, which is under subkey `Control Panel`, which is under root key `HKEY_CURRENT_USER`.

```
mousechar = winqueryreg('name', 'HKEY_CURRENT_USER', ...
 'control panel\mouse');
```

For each name in the `mousechar` list, get its value from the registry and then display the name and its value:

```
for k=1:length(mousechar)
 setting = winqueryreg('HKEY_CURRENT_USER', ...
 'control panel\mouse', mousechar{k});
 str = sprintf('%s = %s', mousechar{k}, num2str(setting));
 disp(str)
end
```

```
ActiveWindowTracking = 0
DoubleClickHeight = 4
DoubleClickSpeed = 830
DoubleClickWidth = 4
MouseSpeed = 1
MouseThreshold1 = 6
MouseThreshold2 = 10
SnapToDefaultButton = 0
SwapMouseButtons = 0
```

# wk1info

---

**Purpose** Determine whether file contains 1-2-3 WK1 worksheet

---

**Note** wk1info has been removed.

---

**Syntax** [extens, typ] = wk1info(filename)

**Description** [extens, typ] = wk1info(filename) returns the string 'WK1' in extens, and '1-2-3 Spreadsheet' in typ if the file filename contains a readable worksheet. The filename input is a string enclosed in single quotes.

**Examples** This example returns information on spreadsheet file matA.wk1:

```
[extens, typ] = wk1info('matA.wk1')

extens =
 WK1
typ =
 123 Spreadsheet
```

**See Also** xlsread | xlswrite | dlmread | dlmwrite

## Purpose

Read Lotus 1-2-3 WK1 spreadsheet file into matrix

---

**Note** wk1read has been removed.

---

## Syntax

```
M = wk1read(filename)
M = wk1read(filename,r,c)
M = wk1read(filename,r,c,range)
```

## Description

`M = wk1read(filename)` reads a Lotus1-2-3 WK1 spreadsheet file into the matrix `M`. The `filename` input is a string enclosed in single quotes.

`M = wk1read(filename,r,c)` starts reading at the row-column cell offset specified by  $(r,c)$ . `r` and `c` are zero based so that `r=0, c=0` specifies the first value in the file.

`M = wk1read(filename,r,c,range)` reads the range of values specified by the parameter `range`, where `range` can be

- A four-element vector specifying the cell range in the format

```
[upper_left_row upper_left_col lower_right_row lower_right_col]
```

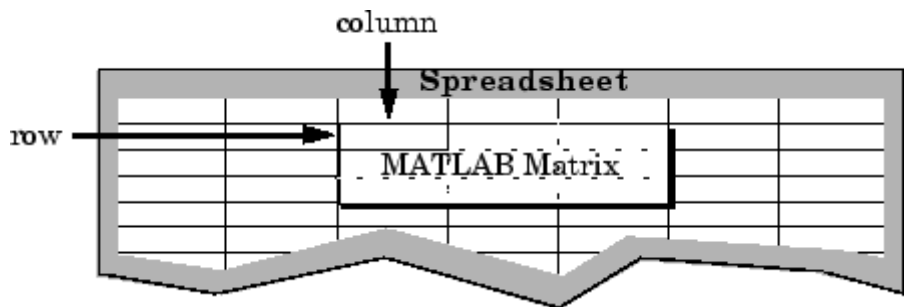

- A cell range specified as a string, for example, 'A1...C5'
- A named range specified as a string, for example, 'Sales'

## Examples

Create a 8-by-8 matrix A and export it to Lotus spreadsheet matA.wk1:

```
A = [1:8; 11:18; 21:28; 31:38; 41:48; 51:58; 61:68; 71:78]
A =
```

1	2	3	4	5	6	7	8
11	12	13	14	15	16	17	18
21	22	23	24	25	26	27	28
31	32	33	34	35	36	37	38
41	42	43	44	45	46	47	48
51	52	53	54	55	56	57	58
61	62	63	64	65	66	67	68
71	72	73	74	75	76	77	78

```
wk1write('matA.wk1', A);
```

To read in a limited block of the spreadsheet data, specify the upper left row and column of the block using zero-based indexing:

```
M = wk1read('matA.wk1', 3, 2)
M =
```

33	34	35	36	37	38
43	44	45	46	47	48
53	54	55	56	57	58
63	64	65	66	67	68
73	74	75	76	77	78

To select a more restricted block of data, you can specify both the upper left and lower right corners of the block you want imported. Read in a range of values from row 4, column 3 (defining the upper left corner) to row 6, column 6 (defining the lower right corner). Note that, unlike the second and third arguments, the range argument [4 3 6 6] is one-based:

```
M = wk1read('matA.wk1', 3, 2, [4 3 6 6])
M =
```

33	34	35	36
43	44	45	46
53	54	55	56

**See Also**

xlsread

# wk1write

## Purpose

Write matrix to Lotus 1-2-3 WK1 spreadsheet file

---

**Note** wk1write has been removed.

---

## Syntax

```
wk1write(filename,M)
wk1write(filename,M,r,c)
```

## Description

wk1write(filename,M) writes the matrix M into a Lotus1-2-3 WK1 spreadsheet file named filename. The filename input is a string enclosed in single quotes.

wk1write(filename,M,r,c) writes the matrix starting at the spreadsheet location (r,c). r and c are zero based so that r=0, c=0 specifies the first cell in the spreadsheet.

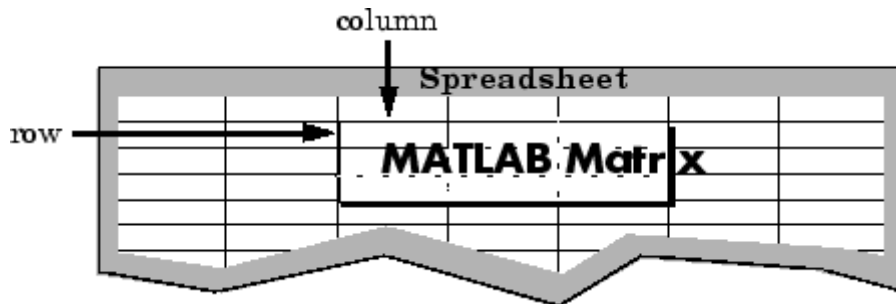

## Examples

Write a 4-by-5 matrix A to spreadsheet file matA.wk1. Place the matrix with its upper left corner at row 2, column 3 using zero-based indexing:

```
A = [1:5; 11:15; 21:25; 31:35]
```

```
A =
```

1	2	3	4	5
11	12	13	14	15
21	22	23	24	25
31	32	33	34	35

```
wk1write('matA.wk1', A, 2, 3)
```

```
M = wk1read('matA.wk1')
```

```
M =
```

```
 0 0 0 0 0 0 0 0
 0 0 0 0 0 0 0 0
 0 0 0 1 2 3 4 5
 0 0 0 11 12 13 14 15
 0 0 0 21 22 23 24 25
 0 0 0 31 32 33 34 35
```

## See Also

[dlmwrite](#) | [dlmread](#) | [xlswrite](#) | [xlsread](#)

# workspace

---

**Purpose** Open Workspace browser to manage workspace

**Syntax** workspace

**Description** workspace displays the Workspace browser, a graphical user interface that allows you to view and manage the contents of the workspace in MATLAB. It provides a graphical representation of the whos display, and allows you to perform the equivalent of the clear, load, open, and save functions.

The Workspace browser also displays and automatically updates statistical calculations for each variable, which you can choose to show or hide.



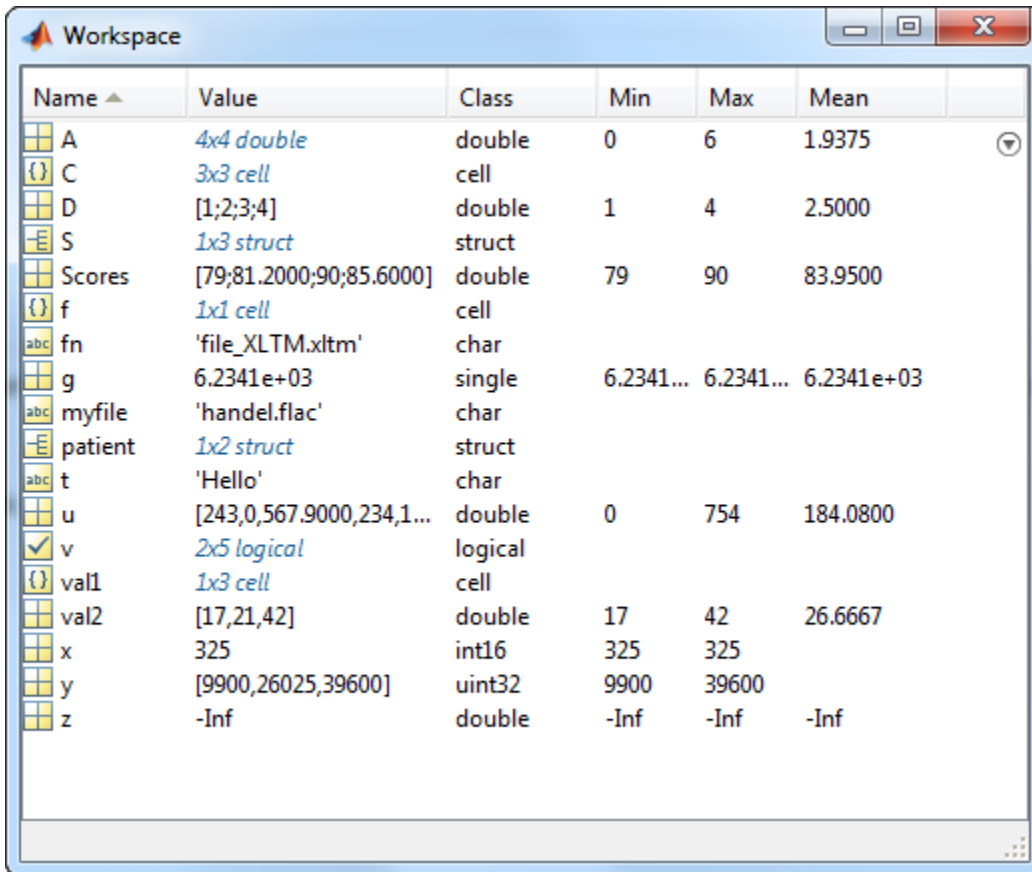

Name ▲	Value	Class	Min	Max	Mean	
A	4x4 double	double	0	6	1.9375	
C	3x3 cell	cell				
D	[1;2;3;4]	double	1	4	2.5000	
S	1x3 struct	struct				
Scores	[79;81.2000;90;85.6000]	double	79	90	83.9500	
f	1x1 cell	cell				
fn	'file_XLTM.xltn'	char				
g	6.2341e+03	single	6.2341...	6.2341...	6.2341e+03	
myfile	'handel.flac'	char				
patient	1x2 struct	struct				
t	'Hello'	char				
u	[243,0,567.9000,234,1...	double	0	754	184.0800	
v	2x5 logical	logical				
val1	1x3 cell	cell				
val2	[17,21,42]	double	17	42	26.6667	
x	325	int16	325	325		
y	[9900,26025,39600]	uint32	9900	39600		
z	-Inf	double	-Inf	-Inf	-Inf	

You can edit a value directly in the Workspace browser for small numeric and character arrays. To see and edit a graphical representation of larger variables and for other classes, double-click the variable in the Workspace browser. The variable displays in the Variables editor, where you can view the full contents and make changes.

## See Also

[openvar](#) | [who](#)

## How To

- “What Is the MATLAB Workspace?”

# writetable

---

**Purpose** Write table to file

**Syntax**  
`writetable(T)`  
`writetable(T,filename)`  
`writetable( ____,Name,Value)`

**Description** `writetable(T)` writes the table, `T`, to a comma delimited text file. The file name is the workspace variable name of the table, appended with the extension `.txt`. If `writetable` cannot construct the file name from the input table name, then it writes to the file `table.txt`.

Each column of each variable in `T` becomes a column in the output file. The variable names of `T` become column headings in the first line of the file.

`writetable(T,filename)` writes table `T` to a file with the name and extension specified by `filename`.

`writetable` determines the file format based on the specified extension. The extension must be one of the following:

- `.txt`, `.dat`, or `.csv` for delimited text files
- `.xls`, `.xlsb`, `.xlsm`, or `.xlsx` for Excel spreadsheet files

`writetable( ____,Name,Value)` writes the table to a file with additional options specified by one or more `Name,Value` pair arguments and can include any of the input arguments in previous syntaxes.

For example, you can specify whether to write the variable names as column headings in the output file.

## **Input Arguments**

**T - Input table**  
`table`

Input table, specified as a table.

**filename - Name of file to write**

string

Name of file to write, specified as a string. If `filename` includes the file's extension, then `writetable` determines the file format from the extension. Otherwise, `writetable` creates a comma separated text file and appends the extension `.txt`. Alternatively, you can specify `filename` without the file's extension, and then include the `'FileType'` name-value pair arguments to indicate the type of file.

If `filename` does not exist in your current folder, then `writetable` creates the file. `writetable` overwrites any existing file.

**Example:** `'myData.xls'`

## Name-Value Pair Arguments

Specify optional comma-separated pairs of `Name,Value` arguments. `Name` is the argument name and `Value` is the corresponding value. `Name` must appear inside single quotes (`' '`). You can specify several name and value pair arguments in any order as `Name1,Value1,...,NameN,ValueN`.

**Example:** `'WriteVariableNames',false` indicates that the variable names should not be included as the first row of the output file.

## 'FileType' - Type of file

`'text' | 'spreadsheet'`

Type of file, specified as the comma-separated pair consisting of `'FileType'` and the string `'text'` or `'spreadsheet'`.

The `'FileType'` name-value pair must be used with the `filename` input argument. You do not need to specify the `'FileType'` name-value pair argument if the file type can be determined from an extension in the `filename` input argument.

- `.txt`, `.dat`, or `.csv` for delimited text files
- `.xls`, `.xlsb`, `.xlsm`, or `.xlsx` for Excel spreadsheet files

**Example:**

```
writetable(T,'mySpreadsheet','FileType','spreadsheet')
```

## **'WriteVariableNames' - Indicator for writing variable names as column headings**

true (default) | false | 1 | 0

Indicator for writing variable names as column headings, specified as the comma-separated pair consisting of 'WriteVariableNames' and either true, false, 1, or 0.

true	writetable includes variable names as the column headings of the output. This is the default behavior.  If both the 'WriteVariablesNames' and 'WriteRowNames' logical indicators are true, then writetable uses the first dimension name from the property T.Properties.DimensionNames as the column heading for the first column of the output.
false	writetable does not include variable names in the output.

## **'WriteRowNames' - Indicator for writing row names in first column**

false (default) | true | 0 | 1

Indicator for writing row names in first column, specified as the comma-separated pair consisting of 'WriteRowNames' and either false, true, 0, or 1.

true	writetable includes the row names from T as the first column of the output.  If both the 'WriteVariablesNames' and 'WriteRowNames' logical indicators are true, then writetable uses the first dimension name from the property T.Properties.DimensionNames as the column heading for the first column of the output.
false	writetable does not include the row names from T in the output. This is the default behavior.

**'Delimiter' - Field delimiter character**

string

Field delimiter character, specified as the comma-separated pair consisting of 'Delimiter' and one of the following strings:

' , '	Comma. This is the default behavior.
' comma '	
' ' '	Space
' space '	
' \t '	Tab
' tab '	
' ; '	Semicolon
' semi '	
'   '	Vertical bar
' bar '	

You can use the 'Delimiter' name-value pair only for delimited text files.

**Example:** 'Delimiter', 'space'

**'Sheet' - Worksheet to write to**

string containing worksheet name | positive integer indicating worksheet index

Worksheet to write to, specified as the comma-separated pair consisting of 'Sheet' and a string containing the worksheet name or a positive integer indicating the worksheet index. The worksheet name string cannot contain a colon (:). To determine the names of sheets in a spreadsheet file, use `[status,sheets] = xlsinfo(filename)`.

If the sheet does not exist, then writetable adds a new sheet at the end of the worksheet collection. If the sheet is an index larger than the number of worksheets, then writetable appends empty sheets until

# writetable

the number of worksheets in the workbook equals the sheet index. In either case, writetable generates a warning indicating that it has added a new worksheet.

You can use the 'Sheet' name-value pair only with spreadsheet files.

**Example:** 'Sheet',2

## 'Range' - Rectangular portion of worksheet to write to string

Rectangular portion of worksheet to write to, specified as the comma-separated pair consisting of 'Range' and a string in one of the following forms.

Form of the Value of Range	Description
'Corner1'	<p><i>Corner1</i> specifies the first cell of the region to write. writetable writes table T beginning at this cell.</p> <p><b>Example:</b> 'Range', 'D2'</p>
'Corner1:Corner2'	<p><i>Corner1</i> and <i>Corner2</i> are two opposing corners that define the region to write. For example, 'D2:H4' represents the 3-by-5 rectangular region between the two corners D2 and H4 on the worksheet. The 'Range' name-value pair argument is not case sensitive, and uses Excel A1 reference style (see Excel help).</p> <p>If the range you specify is larger than the size of the input table T, Excel software fills the remainder of the region with #N/A. If the range specified is smaller than the size of the input table T, then writetable writes only the subset that fits into the range.</p> <p><b>Example:</b> 'Range', 'D2:H4'</p>

The 'Range' name-value pair can only be used with Excel files.

## Examples

### Write Table to Text File

Create a table.

```
T = table(['M';'F';'M'],[45 45;41 32;40 34],...
 {'NY';'CA';'MA'},[true;false;false])
```

T =

Var1	Var2	Var3	Var4
M	45	45	'NY'
F	41	32	'CA'
M	40	34	'MA'

Write the table, T, to a comma delimited text file.

```
writetable(T)
```

writetable outputs a text file named T.txt.

Display the contents of the file.

```
type 'T.txt'
```

```
Var1,Var2_1,Var2_2,Var3,Var4
M,45,45,NY,1
F,41,32,CA,0
M,40,34,MA,0
```

writetable appends a unique suffix to the variable name, Var2, above the two columns of corresponding data.

### Write Table to Space Delimited Text File

Create a table.

```
T = table(['M';'F';'M'],[45 45;41 32;40 34],...
 {'NY';'CA';'MA'},[true;false;false])
```

# writetable

---

```
T =
 Var1 Var2 Var3 Var4

 M 45 45 'NY' true
 F 41 32 'CA' false
 M 40 34 'MA' false
```

Write the table, T, to a space delimited text file, called myData.txt.

```
writetable(T,'myData.txt','Delimiter',' ')
```

Display the contents of the file.

```
type 'myData.txt'
```

```
Var1 Var2_1 Var2_2 Var3 Var4
M 45 45 NY 1
F 41 32 CA 0
M 40 34 MA 0
```

writetable appends a unique suffix to the variable name, Var2, above the two columns of corresponding data.

## Write Table to Text File Including Row Names

Create a table.

```
LastName = {'Smith';'Johnson';'Williams';'Jones';'Brown'};
Age = [38;43;38;40;49];
Height = [71;69;64;67;64];
Weight = [176;163;131;133;119];
BloodPressure = [124 93; 109 77; 125 83; 117 75; 122 80];
```

```
T = table(Age,Height,Weight,BloodPressure,...
 'RowNames',LastName)
```

```
T =
 Age Height Weight BloodPressure

 38 71 176 [124 93]
 43 69 163 [109 77]
 38 64 131 [125 83]
 40 67 133 [117 75]
 49 64 119 [122 80]
```



Smith	38	71	176	124	93
Johnson	43	69	163	109	77
Williams	38	64	131	125	83
Jones	40	67	133	117	75
Brown	49	64	119	122	80

Write the table, T, to a comma delimited text file, called myPatientData.dat.

```
writetable(T,'myPatientData.dat','WriteRowNames',true)
```

Display the contents of the file.

```
type 'myPatientData.dat'
```

```
Row, Age, Height, Weight, BloodPressure_1, BloodPressure_2
Smith, 38, 71, 176, 124, 93
Johnson, 43, 69, 163, 109, 77
Williams, 38, 64, 131, 125, 83
Jones, 40, 67, 133, 117, 75
Brown, 49, 64, 119, 122, 80
```

The first column, which contains the row names, has the column heading, Row. This is the first dimension name for the table from the property T.Properties.DimensionNames.

### Write Table to Specific Sheet and Range in Spreadsheet

Create a table.

```
T = table(['M';'F';'M'],[45 45;41 32;40 34],...
 {'NY';'CA';'MA'},[true;false;false])
```

```
T =
```

Var1	Var2	Var3	Var4
_____	_____	_____	_____

# writetable

---

M	45	45	'NY'	true
F	41	32	'CA'	false
M	40	34	'MA'	false

Write the table, `T`, to a spreadsheet, called `myData.xls`. Include the data on the second sheet in the 5-by-5 region with corners at B2 and F6.

```
writetable(T, 'myData.xls', 'Sheet', 2, 'Range', 'B2:F6')
```

Excel fills the row of the spreadsheet from B6 to F6 with #N/A since the range specified is larger than the size of the input table `T`.

## Algorithms

Excel converts Inf values to 65535. MATLAB converts NaN values to empty cells.

## Tips

- In the cases below, `writetable` creates a file that does not represent `T` exactly. Then, if you use `readtable` to read that file and create a new table, the result might not have the same format or contents as the original table. Save `T` as a MAT-file if you need to import it again as a table with the same data and organization.
  - `writetable` outputs numeric variables using long g format, and categorical or character variables as unquoted strings in text files.
  - For variables that have more than one column, `writetable` appends a unique identifier to the variable name to use as the column headings.
  - For output variables that have more than two dimensions, `writetable` outputs these variables as two dimensional where the trailing dimensions are collapsed. For example, `writetable` outputs a 4-by-3-by-2 variable as if its size were 4-by-6.
  - For variables with a `cell` data type, `writetable` outputs the contents of each cell as a single row, in multiple fields. If the contents are other than numeric, logical, character, or categorical, then `writetable` outputs a single empty field.

**See Also**    `table` | `readtable`

# Tiff.write

---

**Purpose** Write entire image

**Syntax** `tiffobj.write(imageData)`  
`tiffobj.write(Y,Cb,Cr)`

**Description** `tiffobj.write(imageData)` writes `imageData` to TIFF file associated with the Tiff object, `tiffobj`. The write method breaks the data into strips or tiles, depending on the value of the `RowsPerStrip` tag, or the `TileLength` and `TileWidth` tags.

`tiffobj.write(Y,Cb,Cr)` writes the YCbCr component data to the TIFF file. Use this syntax only for images with a YCbCr photometric interpretation.

## **Examples** Write Image Data

Write tags and image data to a new TIFF file.

Read sample data into an array, `imdata`. Create a Tiff object associated with a new file, `myfile.tif`, and open the file for writing.

```
imdata = imread('example.tif');
t = Tiff('myfile.tif','w');
```

Set tag values.

```
t.setTag('ImageLength',size(imdata,1));
t.setTag('ImageWidth',size(imdata,2));
t.setTag('Photometric',Tiff.Photometric.RGB);
t.setTag('BitsPerSample',8);
t.setTag('SamplesPerPixel',size(imdata,3));
t.setTag('TileWidth',128);
t.setTag('TileLength',128);
t.setTag('Compression',Tiff.Compression.JPEG);
t.setTag('PlanarConfiguration',Tiff.PlanarConfiguration.Chunky);
t.setTag('Software','MATLAB');
```

Write the image data to the TIFF file.

```
t.write(imdata);
t.close();
```

## See Also

Tiff.writeDirectory

## Tutorials

- “Exporting Image Data and Metadata to TIFF Files”

# Tiff.writeDirectory

---

**Purpose** Create new IFD and make it current IFD

**Syntax** `tiffobj.writeDirectory()`

**Description** `tiffobj.writeDirectory()` create a new image file directory (IFD) and makes it the current IFD. Tiff object methods operate on the current IFD. If you are creating a TIFF file that only contains one image, you do not need to use this method. With single-image TIFF files, just close the Tiff object to write data to the file.

**Examples** Open a TIFF file for modification and create a new IFD in the file. `writeDirectory` makes the newly created IFD the current IFD. Replace the name `myfile.tif` with the name of a TIFF file on your MATLAB path.

```
t = Tiff('myfile.tif', 'r+');
dnum = t.currentDirectory();
t.writeDirectory();
dnum = t.currentDirectory();
```

**References** This method corresponds to the `TIFFWriteDirectory` function in the LibTIFF C API. To use this method, you must be familiar with the TIFF specification and technical notes. View this documentation at [LibTIFF - TIFF Library and Utilities](#).

**See Also** `Tiff.write` | `Tiff.close`

**Tutorials**

- “Exporting Image Data and Metadata to TIFF Files”
- “Reading Image Data and Metadata from TIFF Files”

**Purpose** Write data to specified strip

**Syntax** `tiffobj.writeEncodedStrip(stripNumber,imageData)`  
`tiffobj.writeEncodedStrip(stripNumber,Y,Cb,Cr)`

**Description** `tiffobj.writeEncodedStrip(stripNumber,imageData)` writes the data in `imageData` to the strip specified by `stripNumber`. Strip identification numbers are one-based. If `imageData` has fewer bytes than fit into a strip, `writeEncodedStrip` silently pads the strip. If `imageData` has more bytes than fit into a strip, `writeEncodedStrip` issues a warning and truncates the data. To determine the size of a strip, view the value of the `RowsPerStrip` tag.

`tiffobj.writeEncodedStrip(stripNumber,Y,Cb,Cr)` writes the YCbCr component data to the specified tile. You must set the `YCbCrSubSampling` tag.

## Examples **Write Image Data to Strips**

Open a Tiff object for writing and set tag values.

```
t = Tiff('myfile.tif','w');
t.setTag('ImageLength',32);
t.setTag('ImageWidth',32);
t.setTag('Photometric',Tiff.Photometric.MinIsBlack);
t.setTag('BitsPerSample',8);
t.setTag('SamplesPerPixel',1);
t.setTag('RowsPerStrip',16);
t.setTag('PlanarConfiguration',Tiff.PlanarConfiguration.Chunky);
```

Write data to the first and second strips.

```
t.writeEncodedStrip(1,ones(16,32,'uint8'));
t.writeEncodedStrip(2,2*ones(16,32,'uint8'));
t.close();
```

**References** This method corresponds to the `TIFFWriteEncodedStrip` function in the LibTIFF C API. To use this method, you must be familiar with the

# Tiff.writeEncodedStrip

---

TIFF specification and technical notes. View this documentation at [LibTIFF - TIFF Library and Utilities](#).

## See Also

`Tiff.writeEncodedTile`

## Tutorials

- “Exporting Image Data and Metadata to TIFF Files”
- “Reading Image Data and Metadata from TIFF Files”



**Purpose**

Write data to specified tile

**Syntax**

```
tiffobj.writeEncodedTile(tileNumber,imageData)
tiffobj.writeEncodedTile(tileNumber,Y,Cb,Cr)
```

**Description**

`tiffobj.writeEncodedTile(tileNumber,imageData)` writes the data in `imageData` to the tile specified by `tileNumber`. Tile identification numbers are one-based. If `imageData` has fewer bytes than fit into a tile, `writeEncodedTile` silently pads the tile. If `imageData` has more bytes than fit into a tile, `writeEncodedTile` issues a warning and truncates the data. To determine the size of a tile, view the value of the `tileLength` and `tileWidth` tags.

`tiffobj.writeEncodedTile(tileNumber,Y,Cb,Cr)` writes the YCbCr component data to the specified tile. You must set the `YCbCrSubSampling` tags.

**Examples****Write Image Data to Tiles**

Open a Tiff object for writing and set tag values.

```
t = Tiff('myfile.tif','w');
t.setTag('ImageLength',32);
t.setTag('ImageWidth',32);
t.setTag('Photometric',Tiff.Photometric.MinIsBlack);
t.setTag('BitsPerSample',8);
t.setTag('SamplesPerPixel',1);
t.setTag('TileWidth',16);
t.setTag('TileLength',16);
t.setTag('PlanarConfiguration',Tiff.PlanarConfiguration.Chunky);
```

Write data to four tiles.

```
t.writeEncodedTile(1,ones(16,16,'uint8'));
t.writeEncodedTile(2,2*ones(16,16,'uint8'));
t.writeEncodedTile(3,3*ones(16,16,'uint8'));
t.writeEncodedTile(4,4*ones(16,16,'uint8'));
t.close();
```

# Tiff.writeEncodedTile

---

## References

This method corresponds to the `TIFFWriteEncodedTile` function in the LibTIFF C API. To use this method, you must be familiar with the TIFF specification and technical notes. View this documentation at [LibTIFF - TIFF Library and Utilities](#).

## See Also

`Tiff.writeEncodedStrip`

## Tutorials

- “Exporting Image Data and Metadata to TIFF Files”
- “Reading Image Data and Metadata from TIFF Files”

## Purpose

Write video data to file

## Syntax

```
writeVideo(writerObj,img)
writeVideo(writerObj,images)
writeVideo(writerObj,frame)
writeVideo(writerObj,mov)
```

## Description

`writeVideo(writerObj,img)` writes data from an image to a video file.

`writeVideo(writerObj,images)` writes a sequence of color images to a video file.

`writeVideo(writerObj,frame)` writes a frame to the video file associated with `writerObj`.

`writeVideo(writerObj,mov)` writes a MATLAB movie to a video file. `MOV` is an array of frame structures.

You must call `open(writerObj)` before calling `writeVideo`.

## Input Arguments

### **writerObj**

VideoWriter object created by the `VideoWriter` function.

### **img**

When creating AVI or MPEG-4 files, `img` is an array of `single`, `double`, or `uint8` values representing a grayscale or RGB color image, which `writeVideo` writes as an RGB video frame. Data of type `single` or `double` must be in the range `[0,1]`, except when writing Indexed AVI files.

When creating Motion JPEG 2000 files, `img` is an array of `uint8`, `int8`, `uint16`, or `int16` values representing a monochrome or RGB color image.

For grayscale, monochrome, or indexed data, `img` must be two-dimensional: height-by-width. For color data that is not indexed, `img` is three-dimensional: height-by-width-by-3. The height and width must be consistent for all frames within a file. For more information, see “Image Types”.

# VideoWriter.writeVideo

---

## images

Four-dimensional array of grayscale (height-by-width-by-1-by-frames) or RGB (height-by-width-by-3-by-frames) images.

## frame

Structure typically returned by the `getframe` function that contains two fields: `cdata` and `colormap`. If the `colormap` is not empty, `writeVideo` expects a two-dimensional (height-by-width) array `cdata`. The height and width must be consistent for all frames within a file. `colormap` can contain a maximum of 256 entries.

The profile of `writerObj` and the size of `cdata` determine how the `writeVideo` method uses `frame`.

profile of VideoWriter object	Size of cdata	Behavior of writeVideo
'Indexed AVI' or 'Grayscale AVI'	2-dimensional (height-by-width)	Use frame as provided. For 'Grayscale AVI', colormap should be empty.
	3-dimensional (height-by-width-by-3)	Error
All other profiles	2-dimensional (height-by-width)	Construct RGB image frames using the colormap field
	3-dimensional (height-by-width-by-3)	Colormap field ignored. Construct RGB image frames using the cdata field

## **mov**

1-by-F array of frame structures, where F is the number of images.  
Each frame structure contains fields `cdata` and `colormap`.

## **Examples**

### **AVI File from Animation**

Write a sequence of frames to a compressed AVI file, `peaks.avi`.

Prepare the new file.

```
writerObj = VideoWriter('peaks.avi');
open(writerObj);
```

Generate initial data and set axes and figure properties.

```
Z = peaks; surf(Z);
axis tight
set(gca, 'nextplot', 'replacechildren');
set(gcf, 'Renderer', 'zbuffer');
```

Setting the `Renderer` property to `zbuffer` or `Painters` works around limitations of `getframe` with the OpenGL renderer on some Windows systems.

Create a set of frames and write each frame to the file.

```
for k = 1:20
 surf(sin(2*pi*k/20)*Z,Z)
 frame = getframe;
 writeVideo(writerObj,frame);
end
```

```
close(writerObj);
```

### **MPG to AVI Conversion**

Convert an example file, `xylophone.mp4`, to an uncompressed AVI file:

# VideoWriter.writeVideo

---

Create objects to read and write the video, and open the AVI file for writing.

```
readerObj = VideoReader('xylophone.mp4');
writerObj = VideoWriter('transcoded_xylophone.avi', ...
 'Uncompressed AVI');
```

```
open(writerObj);
```

Read and write each frame.

```
for k = 1:readerObj.NumberOfFrames
 img = read(readerObj,k);
 writeVideo(writerObj,img);
end
```

```
close(writerObj);
```

## See Also

[close](#) | [getframe](#) | [VideoReader](#) | [VideoWriter](#) | [movie2avi](#) | [open](#)

**Purpose**

Label x-axis

**Syntax**

```
xlabel(str)
xlabel(str,Name,Value)

xlabel(axes_handle, ___)

h = xlabel(___)
```

**Description**

`xlabel(str)` labels the *x*-axis of the current axes with the string, `str`. Each axes graphics object has one predefined *x*-axis label. Reissuing the `xlabel` command causes the new label to replace the old label. Labels appear beneath the axis in a two-dimensional view and to the side or beneath the axis in a three-dimensional view.

`xlabel(str,Name,Value)` additionally specifies the text object properties using one or more `Name,Value` pair arguments.

`xlabel(axes_handle, ___ )` adds the label to the axes specified by `axes_handle`. This syntax allows you to specify the axes to which to add a label. `axes_handle` can precede any of the input argument combinations in the previous syntaxes.

`h = xlabel( ___ )` returns the handle to the text object used as the *x*-axis label. The handle is useful when making future modifications to the label.

**Input Arguments****str - Text to display as x-axis label**

string

Text to display as the *x*-axis label, specified as a string or the name of a function that returns a string.

**Example:** 'myLabel'

**axes\_handle - Axes handle**

handle

Axes handle, which is the reference to an axes object. Use the `gca` function to get the handle to the current axes, for example, `axes_handle = gca;`

## Name-Value Pair Arguments

Specify optional comma-separated pairs of `Name`, `Value` arguments. `Name` is the argument name and `Value` is the corresponding value. `Name` must appear inside single quotes ( ' '). You can specify several name and value pair arguments in any order as `Name1,Value1,...,NameN,ValueN`.

**Example:** `'Color','red','FontSize',12` adds an x-axis label with red, 12-point font.

In addition to the following, you can specify other text object properties using `Name`, `Value` pair arguments. See [Text Properties](#).

### 'Color' - Text color

[0 0 0] (black) (default) | 3-element RGB vector | string

Text color, specified as the comma-separated pair consisting of 'Color' and a 3-element RGB vector or a string containing the short or long name of the color. The RGB vector is a 3-element row vector whose elements specify the intensities of the red, green, and blue components of the color. The intensities must be in the range [0 1].

The following table lists the predefined colors and their RGB equivalents.

RGB Value	Short Name	Long Name
[1 1 0]	y	yellow
[1 0 1]	m	magenta
[0 1 1]	c	cyan
[1 0 0]	r	red
[0 1 0]	g	green



RGB Value	Short Name	Long Name
[0 0 1]	b	blue
[1 1 1]	w	white
[0 0 0]	k	black

**Example:** 'Color',[0 1 0]

**Example:** 'Color','green'

### **'FontAngle' - Character slant**

'normal' (default) | 'italic' | 'oblique'

Character slant, specified as the comma-separated pair consisting of 'FontAngle' and one of these values: 'normal', 'italic', or 'oblique'. MATLAB uses the FontAngle property to select a font from those available on your particular system. Generally, setting this property to italic or oblique selects a slanted font.

**Example:** 'FontAngle','italic'

### **'FontName' - Font name**

'Helvetica' (default) | string | 'FixedWidth'

Font name, specified as the comma-separated pair consisting of 'FontName' and a string. The string specifies the name of the font to use for the text object. To display and print properly, this must be a font that your system supports.

To use a fixed-width font that looks good in any locale, use the case-sensitive string 'FixedWidth'. This eliminates the need to hard-code the name of a fixed-width font, which might not display text properly on systems that do not use ASCII character encoding.

**Example:** 'FontName','Courier'

### **'FontSize' - Font size**

10 points (default) | scalar

Font size, specified as the comma-separated pair consisting of 'FontSize' and a scalar in units determined by the FontUnits property. The default value for FontUnits is points.

**Example:** 'FontSize',12.5

## 'FontUnits' - Font size units

'points' (default) | 'normalized' | 'inches' | 'centimeters' | 'pixels'

Font size units, specified as the comma-separated pair consisting of 'FontUnits' and one of the following strings:

- 'points'
- 'normalized'
- 'inches'
- 'centimeters'
- 'pixels'

When the value of FontUnits is 'normalized', MATLAB interprets the value of FontSize as a fraction of the height of the parent axes. When you resize the axes, MATLAB modifies the screen FontSize accordingly. points, inches, centimeters, and pixels are absolute units. 1 point =  $\frac{1}{72}$  inch

---

**Note** When setting both the FontSize and the FontUnits, you must set the FontUnits property first so that MATLAB can correctly interpret the specified FontSize. For example, to set the font size to 0.3 inches, call 'FontUnits', 'inches', 'FontSize', 0.3 in the argument list.

---

## 'FontWeight' - Weight of text characters

'normal' (default) | 'bold' | 'light' | 'demi'

Weight of text characters, specified as the comma-separated pair consisting of 'FontWeight' and one of the following strings:

- 'normal'
- 'bold'
- 'light'
- 'demi'

MATLAB uses the `FontWeight` property to select a font from those available on your particular system. Generally, setting this property to 'bold' or 'demi' causes MATLAB to use a bold font.

**Example:** `'FontWeight','bold'`

### 'Interpreter' - Character interpretation

`'tex'` (default) | `'latex'` | `'none'`

Character interpretation, specified as the comma-separated pair consisting of 'Interpreter' and one of the following strings.

Interpreter value	Result
'tex'	Supports a subset of plain TeX markup language. See the <code>String</code> property for a list of supported TeX instructions.
'latex'	Supports a basic subset of the LaTeX markup language.
'none'	Interprets all characters as literal characters.

**Example:** `'Interpreter','latex'`

## Output Arguments

### **h** - Handle to text object used as x-axis label

scalar

Handle to the text object used as the *x*-axis label, returned as a scalar. This is a unique identifier, which you can use to query and modify the properties of the label.

# xlabel

---

## Examples

### Label x-Axis with String

```
figure
plot((1:10).^2)
xlabel('Population')
```

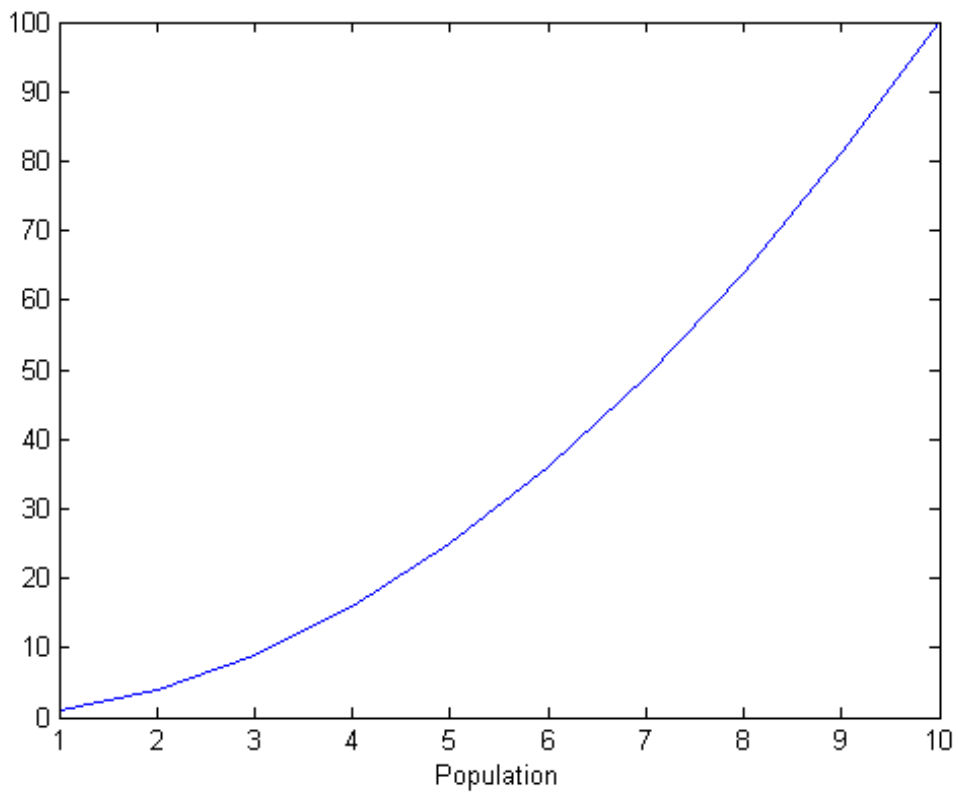

MATLAB® displays Population beneath the x-axis.

**Label x-Axis with Numeric Input**

```
figure
plot((1:10).^2)
xlabel(123)
```

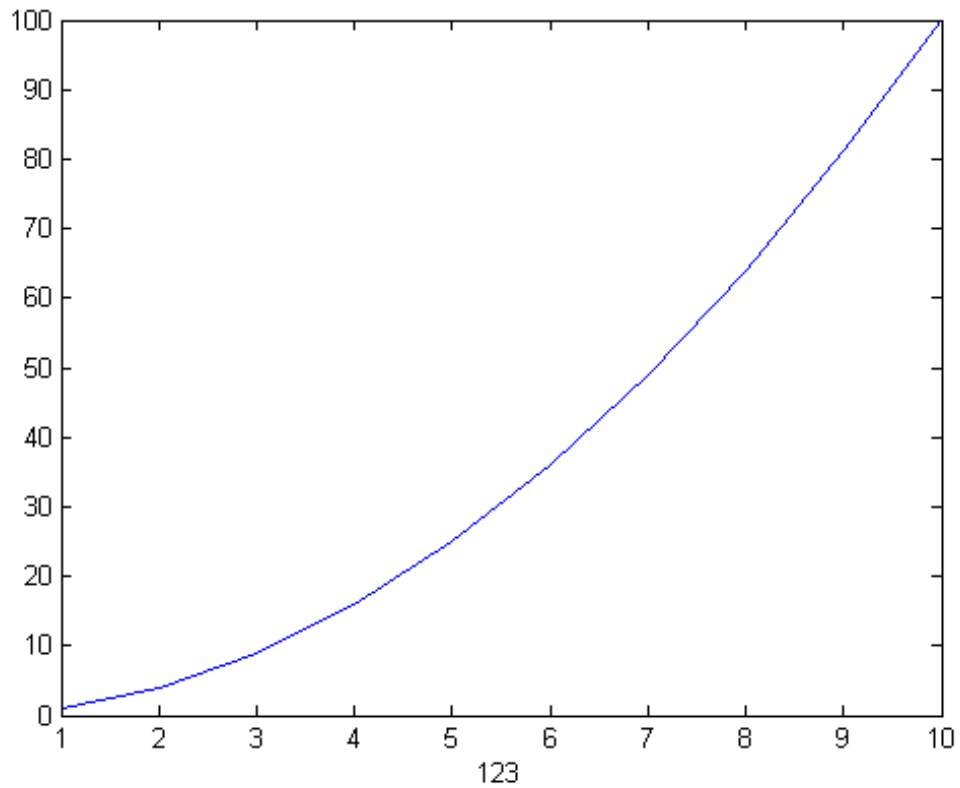

MATLAB® displays 123 beneath the *x*-axis.

**Create Multiline Label**

Create a multiline label using a multiline cell array.

# xlabel

---

```
figure
plot((1:10).^2)
xlabel({date;'Population';'in Years'})
```

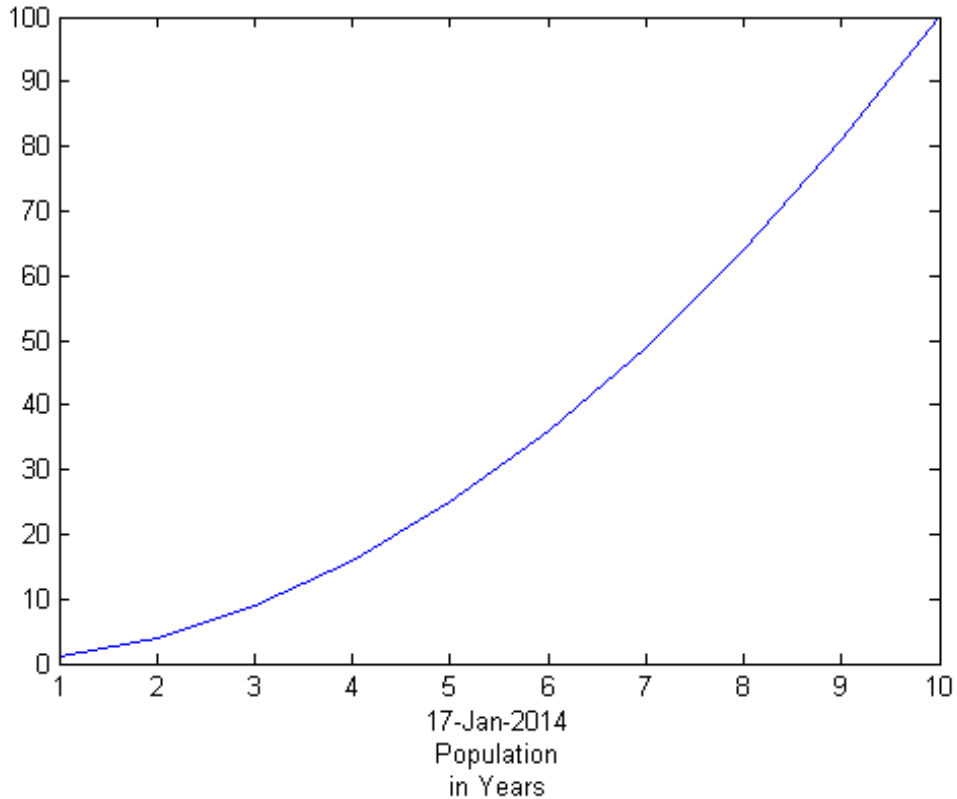

## Include SuperScript or Subscript in Label

Use the '^' and '\_' characters to include superscripts and subscripts in the axis labels. Use braces to modify more than one character.

```
t = linspace(0,1);
```

```
y = exp(t);
figure
plot(t,y);
xlabel('t_{seconds}');
ylabel('e^t')
```

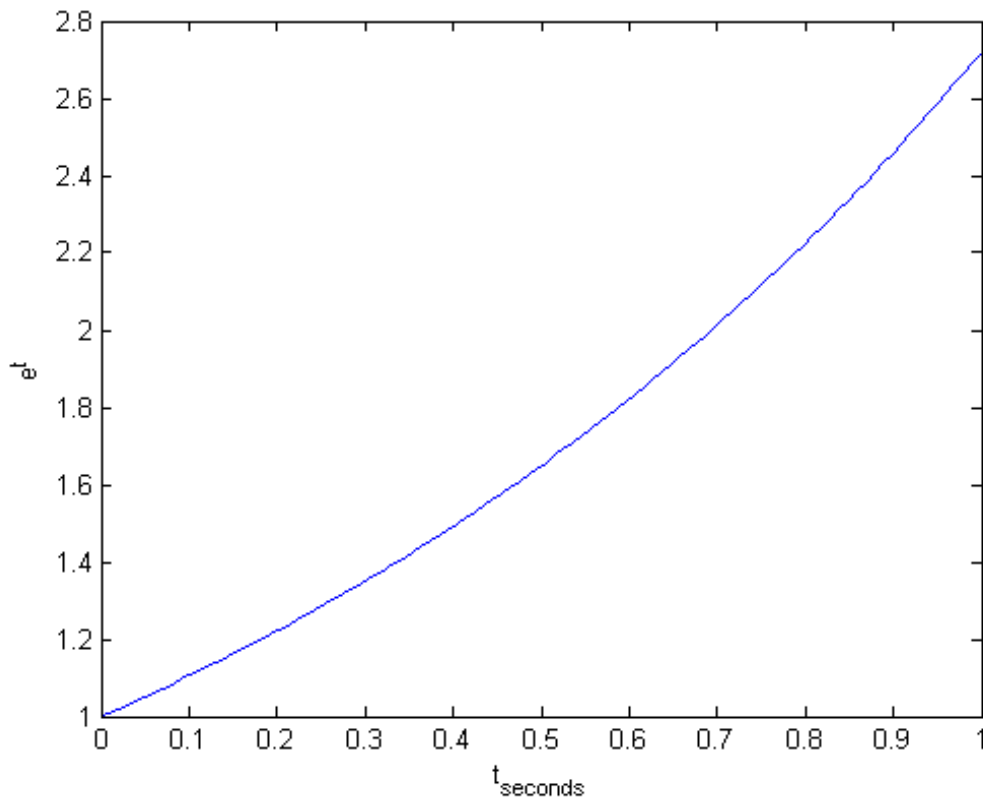

### Create Label and Set Font Properties

Use Name, Value pair arguments to set the font size, font weight, and text color properties of the x-axis label.

# xlabel

---

```
figure
plot((1:10).^2)
xlabel('Population','FontSize',12,...
 'FontWeight','bold','Color','r')
```

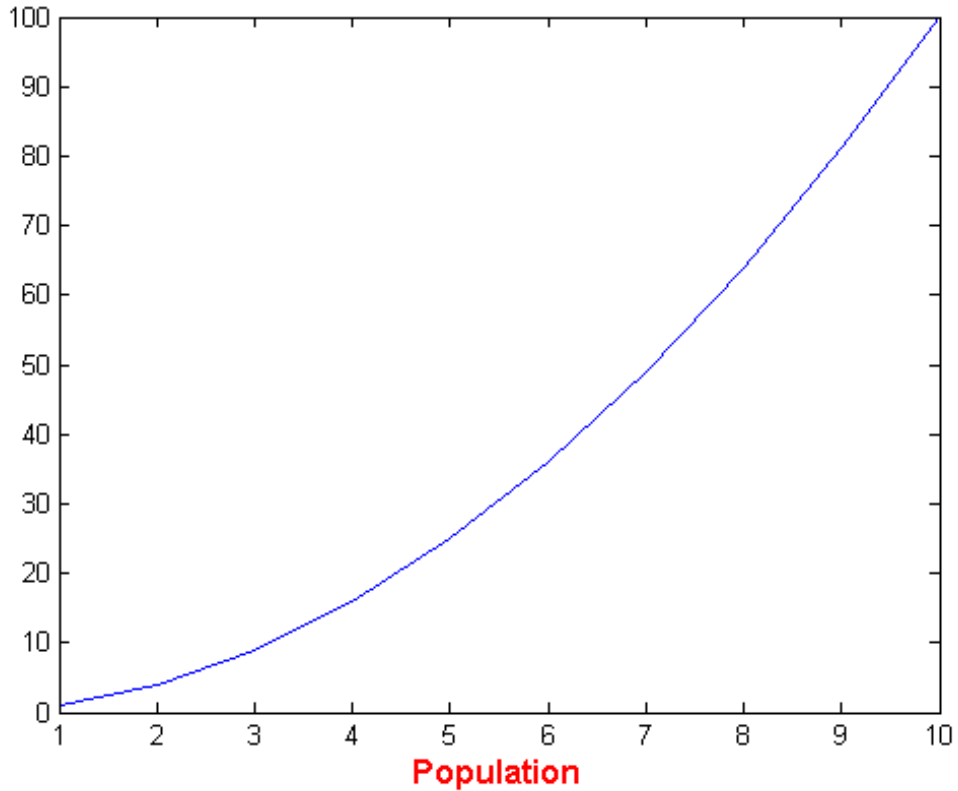

'FontSize',12 displays the label text in 12-point font.  
'FontWeight','bold' makes the text bold. 'Color','r' sets the text color to red.



### **Label x-Axis of Specific Axes**

Create a figure with two subplots and return the axes handles, `s(1)` and `s(2)`.

```
figure
s(1) = subplot(2,1,1);
plot((1:10).^2)
s(2) = subplot(2,1,2);
plot((1:10).^3)
```

# xlabel

---

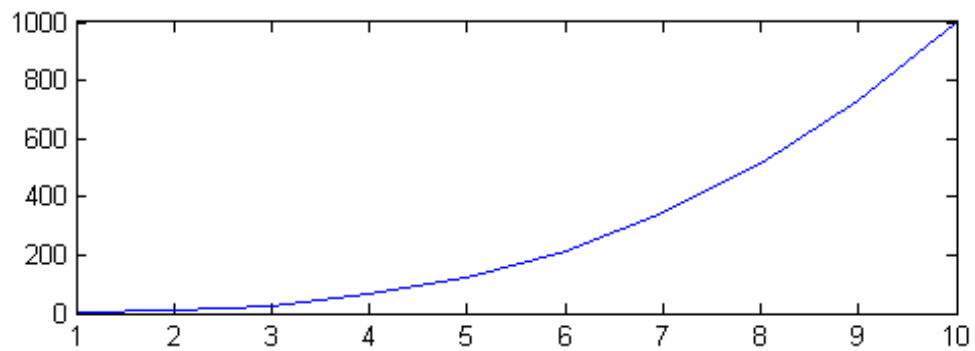
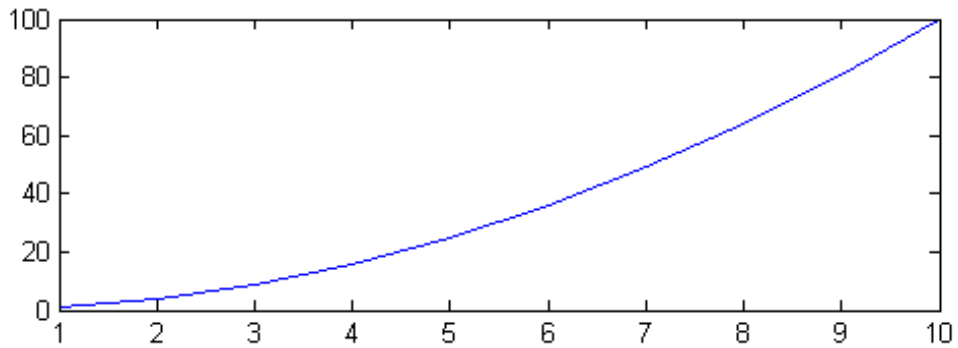

Label the  $x$ -axis of the top plot by referring to its axes handle, `s(1)`.

```
xlabel(s(1), 'Population')
```

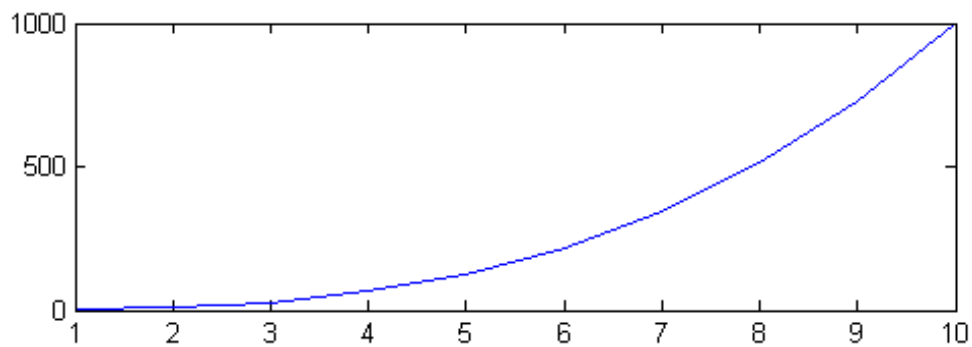
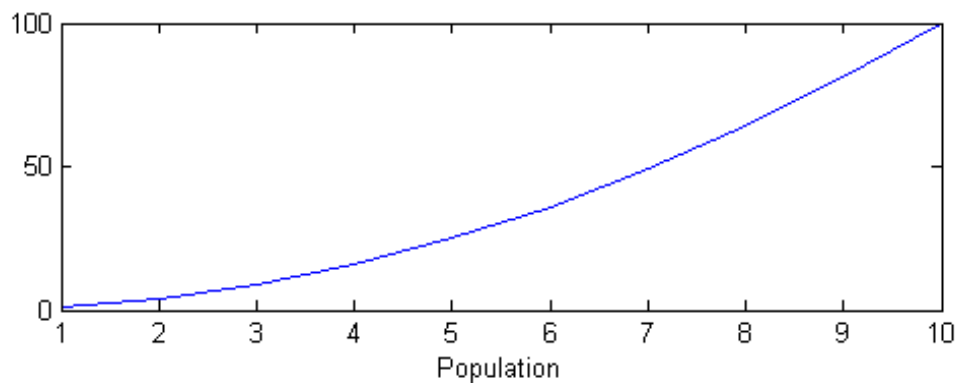

### Label x-Axis and Return Object Handle

Label the  $x$ -axis and return the handle to the text object used as the label.

```
figure
plot((1:10).^2)
str = 'Population';
h = xlabel(str);
```

# xlabel

---

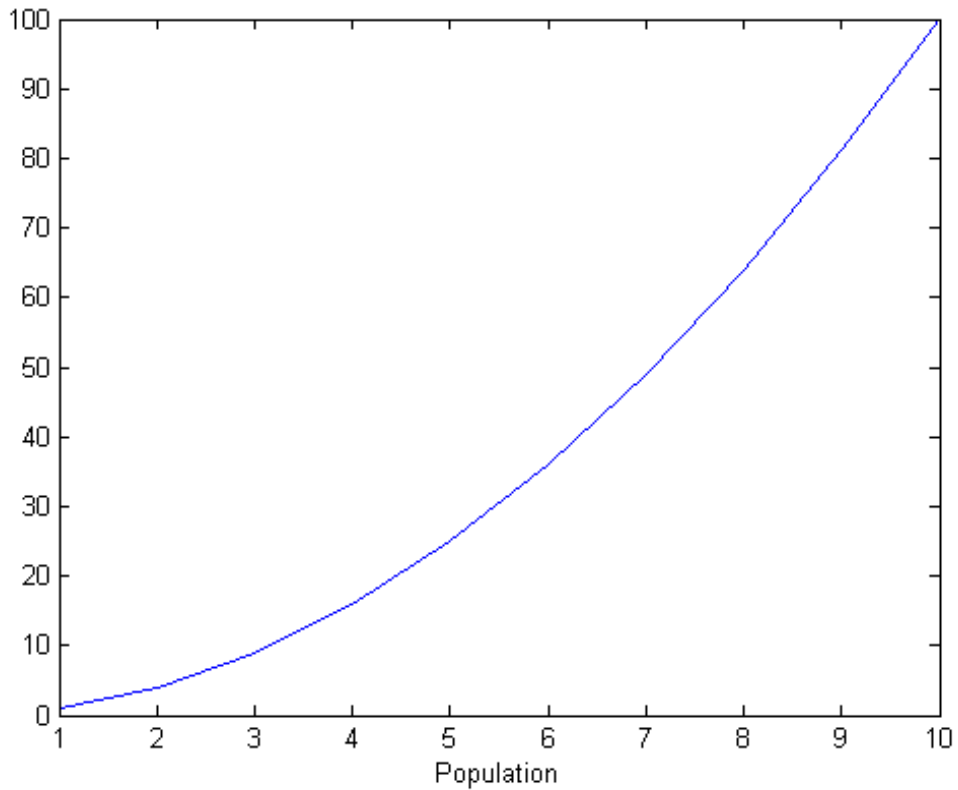

MATLAB® returns the object handle in the output variable, `h`.

Set the color of the label to red, using the handle.

```
set(h, 'Color', 'red')
```

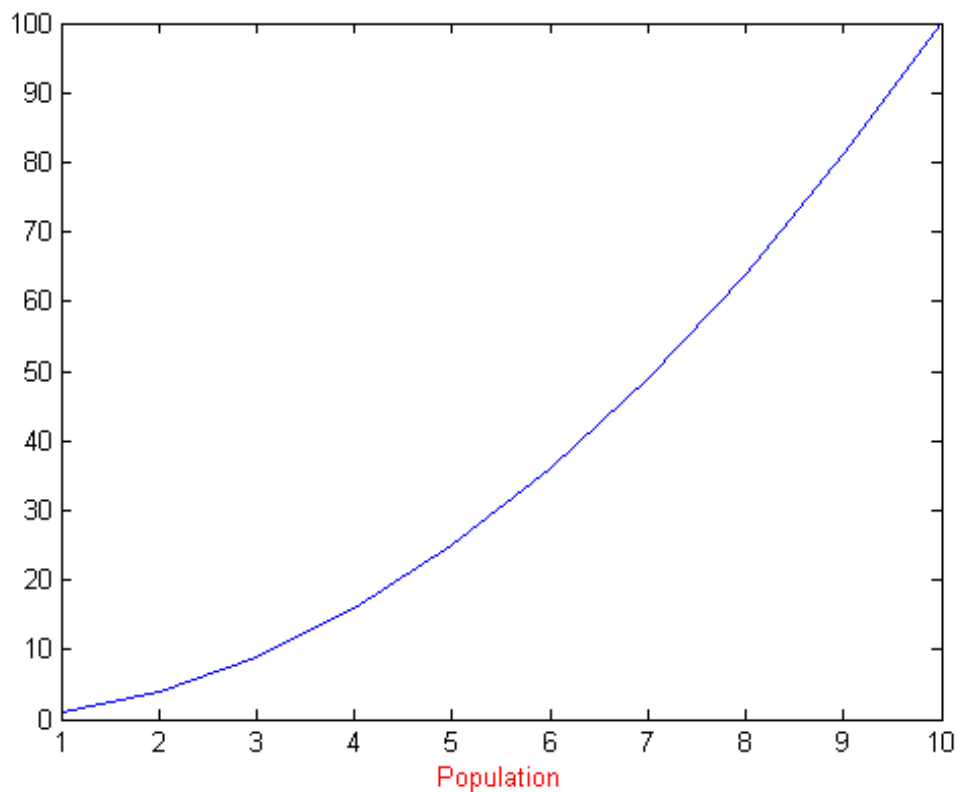
**See Also**

[strings](#) | [ylabel](#) | [zlabel](#) | [text](#) | [title](#)

**Concepts**

- “Add Axis Labels to Graph Using Plot Tools”  
Text Properties

# ylabel

---

## Purpose

Label y-axis

## Syntax

```
ylabel(str)
ylabel(str,Name,Value)

ylabel(axes_handle, ___)

h = ylabel(___)
```

## Description

`ylabel(str)` labels the *y*-axis of the current axes with the string, `str`. Every axes has one predefined *y*-axis label. Reissuing the `ylabel` command causes the new label to replace the old label. Labels appear beside the axis in a two-dimensional view and to the side or in front of the axis in a three-dimensional view.

`ylabel(str,Name,Value)` additionally specifies the text object properties using one or more `Name,Value` pair arguments.

`ylabel(axes_handle, ___ )` adds the label to the axes specified by `axes_handle`. This syntax allows you to specify the axes to which to add a label. `axes_handle` can precede any of the input argument combinations in the previous syntaxes.

`h = ylabel( ___ )` returns the handle to the text object used as the *y*-axis label. The handle is useful when making future modifications to the label.

## Input Arguments

### **str - Text to display as y-axis label**

string

Text to display as the *y*-axis label, specified as a string or the name of a function that returns a string.

**Example:** 'myLabel'

### **axes\_handle - Axes handle**

handle

Axes handle, which is the reference to an axes object. Use the `gca` function to get the handle to the current axes, for example, `axes_handle = gca;`

### Name-Value Pair Arguments

Specify optional comma-separated pairs of `Name`, `Value` arguments. `Name` is the argument name and `Value` is the corresponding value. `Name` must appear inside single quotes ( ' '). You can specify several name and value pair arguments in any order as `Name1,Value1,...,NameN,ValueN`.

**Example:** `'Color','red','FontSize',12` adds a y-axis label with red, 12-point font.

In addition to the following, you can specify other text object properties using `Name`, `Value` pair arguments. See [Text Properties](#).

#### 'Color' - Text color

[0 0 0] (black) (default) | 3-element RGB vector | string

Text color, specified as the comma-separated pair consisting of `'Color'` and a 3-element RGB vector or a string containing the short or long name of the color. The RGB vector is a 3-element row vector whose elements specify the intensities of the red, green, and blue components of the color. The intensities must be in the range [0 1].

The following table lists the predefined colors and their RGB equivalents.

RGB Value	Short Name	Long Name
[1 1 0]	y	yellow
[1 0 1]	m	magenta
[0 1 1]	c	cyan
[1 0 0]	r	red
[0 1 0]	g	green

RGB Value	Short Name	Long Name
[0 0 1]	b	blue
[1 1 1]	w	white
[0 0 0]	k	black

**Example:** 'Color',[0 1 0]

**Example:** 'Color','green'

### **'FontAngle' - Character slant**

'normal' (default) | 'italic' | 'oblique'

Character slant, specified as the comma-separated pair consisting of 'FontAngle' and one of these values: 'normal', 'italic', or 'oblique'. MATLAB uses the FontAngle property to select a font from those available on your particular system. Generally, setting this property to italic or oblique selects a slanted font.

**Example:** 'FontAngle','italic'

### **'FontName' - Font name**

'Helvetica' (default) | string | 'FixedWidth'

Font name, specified as the comma-separated pair consisting of 'FontName' and a string. The string specifies the name of the font to use for the text object. To display and print properly, this must be a font that your system supports.

To use a fixed-width font that looks good in any locale, use the case-sensitive string 'FixedWidth'. This eliminates the need to hard-code the name of a fixed-width font, which might not display text properly on systems that do not use ASCII character encoding.

**Example:** 'FontName','Courier'

### **'FontSize' - Font size**

10 points (default) | scalar



---

Font size, specified as the comma-separated pair consisting of 'FontSize' and a scalar in units determined by the FontUnits property. The default value for FontUnits is points.

**Example:** 'FontSize',12.5

#### 'FontUnits' - Font size units

'points' (default) | 'normalized' | 'inches' | 'centimeters' | 'pixels'

Font size units, specified as the comma-separated pair consisting of 'FontUnits' and one of the following strings:

- 'points'
- 'normalized'
- 'inches'
- 'centimeters'
- 'pixels'

When the value of FontUnits is 'normalized', MATLAB interprets the value of FontSize as a fraction of the height of the parent axes. When you resize the axes, MATLAB modifies the screen FontSize accordingly. points, inches, centimeters, and pixels are absolute units. 1 point =  $1/72$  inch

---

**Note** When setting both the FontSize and the FontUnits, you must set the FontUnits property first so that MATLAB can correctly interpret the specified FontSize. For example, to set the font size to 0.3 inches, call 'FontUnits', 'inches', 'FontSize', 0.3 in the argument list.

---

#### 'FontWeight' - Weight of text characters

'normal' (default) | 'bold' | 'light' | 'demi'

Weight of text characters, specified as the comma-separated pair consisting of 'FontWeight' and one of the following strings:

- 'normal'
- 'bold'
- 'light'
- 'demi'

MATLAB uses the `FontWeight` property to select a font from those available on your particular system. Generally, setting this property to 'bold' or 'demi' causes MATLAB to use a bold font.

**Example:** `'FontWeight','bold'`

### 'Interpreter' - Character interpretation

`'tex'` (default) | `'latex'` | `'none'`

Character interpretation, specified as the comma-separated pair consisting of 'Interpreter' and one of the following strings.

Interpreter value	Result
'tex'	Supports a subset of plain TeX markup language. See the <code>String</code> property for a list of supported TeX instructions.
'latex'	Supports a basic subset of the LaTeX markup language.
'none'	Interprets all characters as literal characters.

**Example:** `'Interpreter','latex'`

## Output Arguments

### **h** - Handle to text object used as y-axis label

scalar

Handle to the text object used as the *y*-axis label, returned as a scalar. This is a unique identifier, which you can use to query and modify the properties of the label.

**Examples**      **Label y-Axis with String**

```
figure
plot((1:10).^2)
ylabel('Population')
```

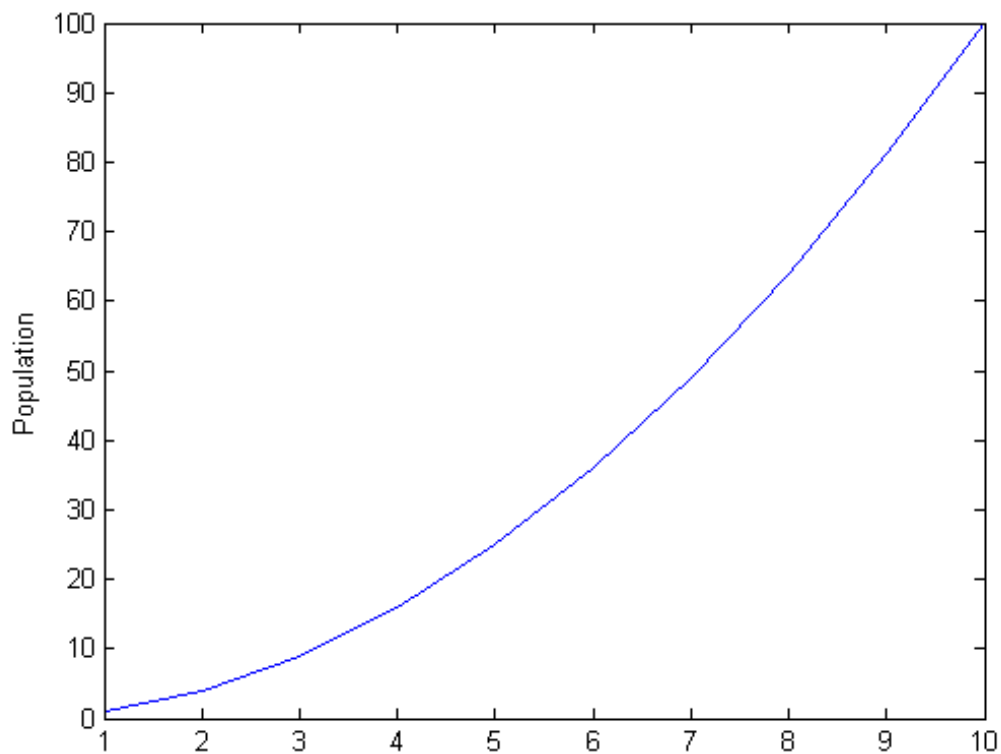

MATLAB® displays Population beside the y-axis.

## Label y-Axis with Numeric Input

```
figure
plot((1:10).^2)
ylabel(123)
```

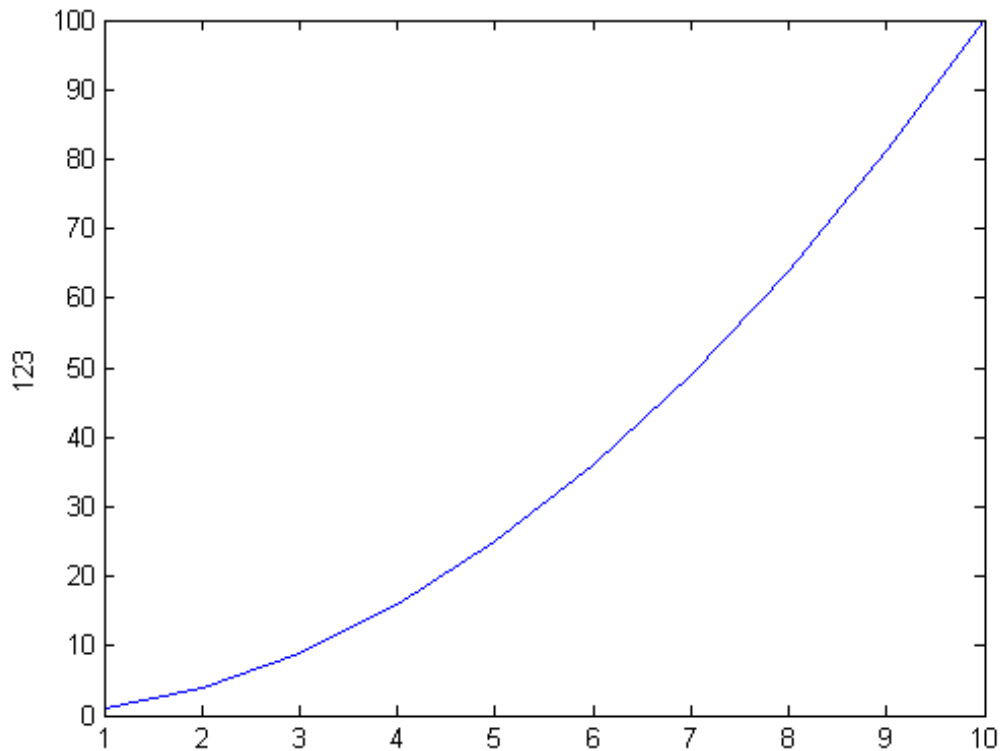

MATLAB® displays 123 beside the y-axis.

### Create Multiline Label

Create a multiline label using a multiline cell array.

```
figure
plot((1:10).^2)
ylabel({'2010'; 'Population'; 'in Years'})
```

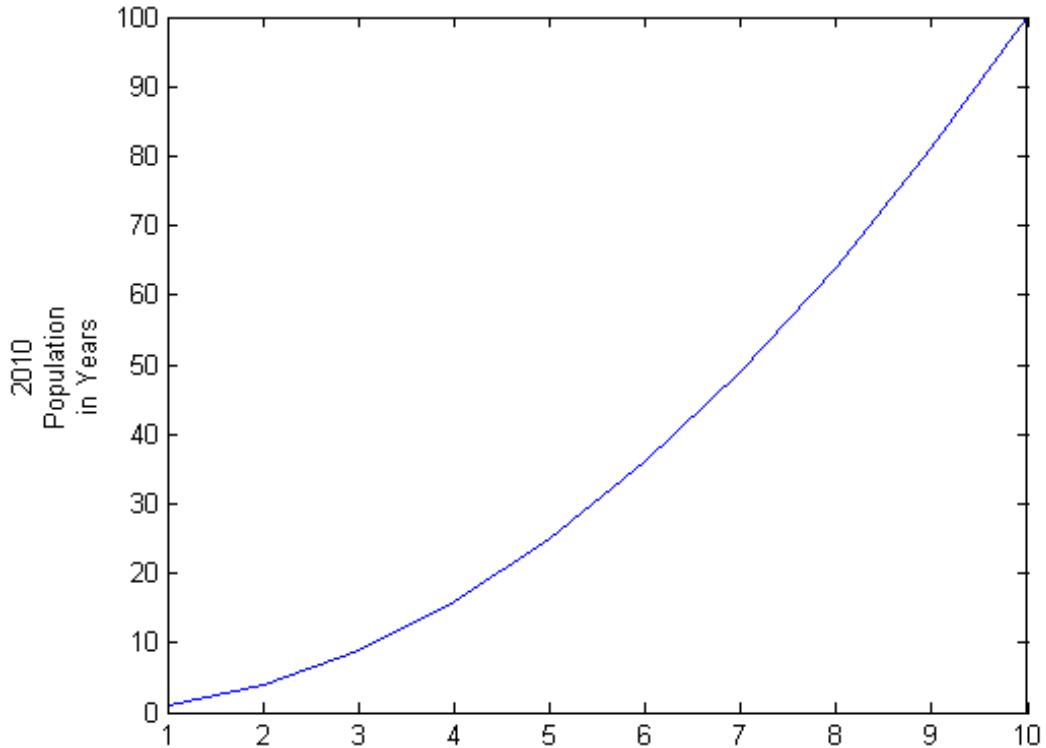

### Include SuperScript or Subscript in Label

Use the '^' and '\_' characters to include superscripts and subscripts in the axis labels. Use braces to modify more than one character.

```
t = linspace(0,1);
```

# ylabel

---

```
y = exp(t);
figure
plot(t,y);
xlabel('t_{seconds}')
ylabel('e^t')
```

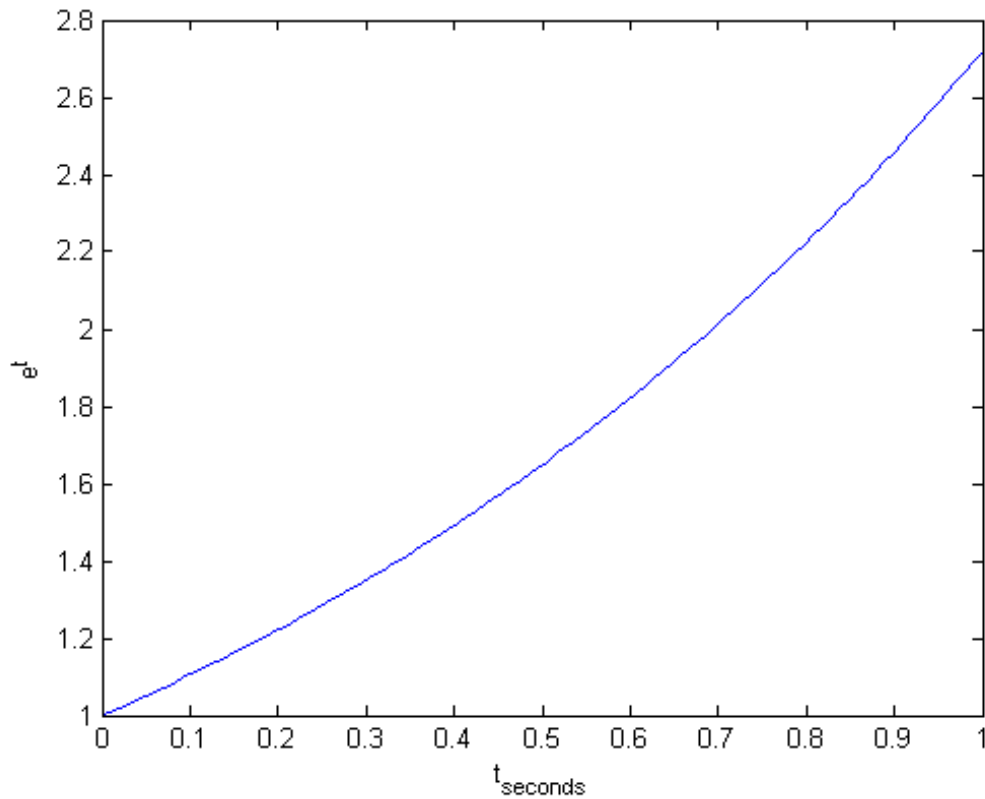

## Create y-Axis Label and Set Font Properties

Use Name, Value pairs to set the font size, font weight, and text color properties of the y-axis label.

```
figure
plot((1:10).^2)
ylabel('Population','FontSize',12,...
 'FontWeight','bold','Color','r')
```

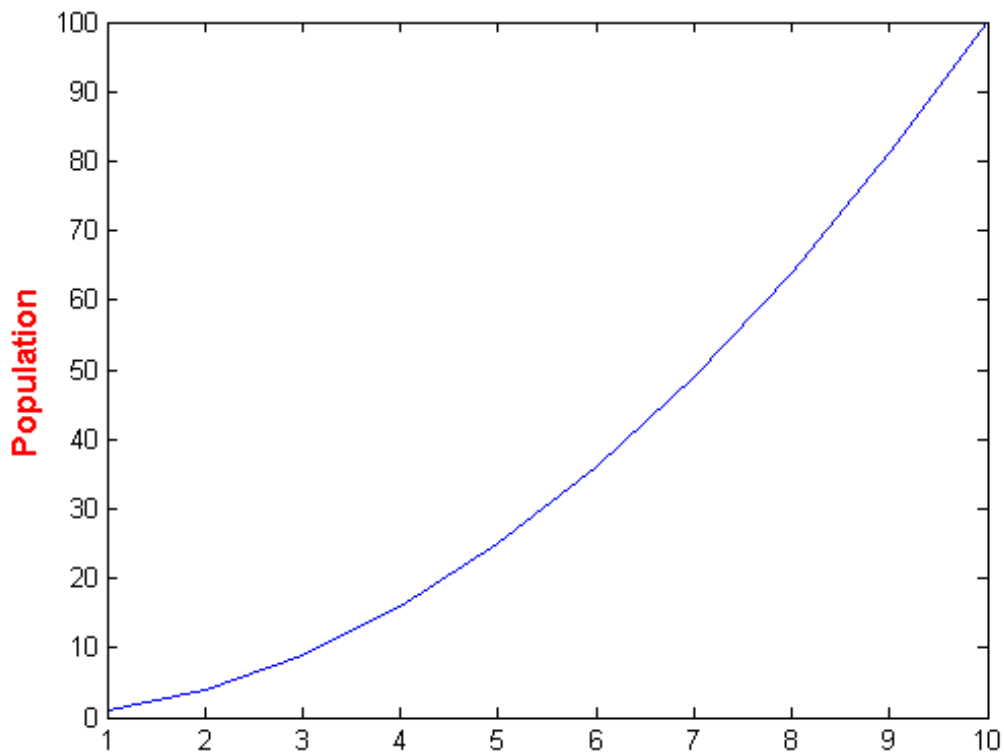

'FontSize',12 displays the label text in 12-point font.  
'FontWeight','bold' makes the text bold. 'Color','r' sets the text color to red.

## Label y-Axis of Specific Axes

Create two subplots and return the axes handles, s(1) and s(2).

```
figure
s(1) = subplot(2,1,1);
plot((1:10).^2)
s(2) = subplot(2,1,2);
plot((1:10).^3)
```

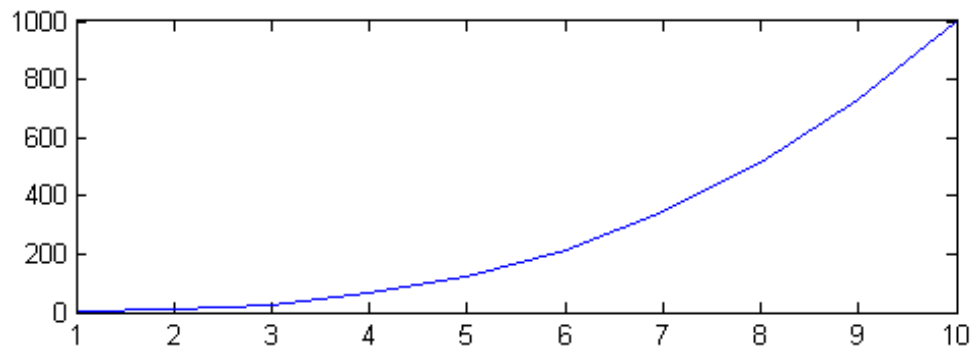
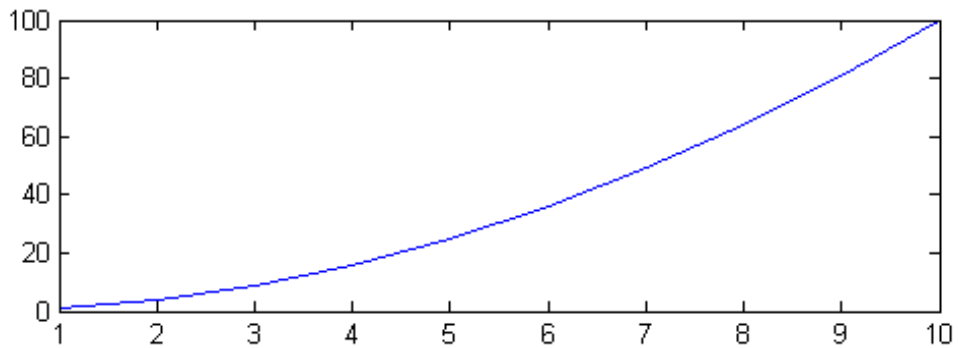



Label the  $y$ -axis of the top plot by referring to its axes handle, `s(1)`.

```
ylabel(s(1), 'Population')
```

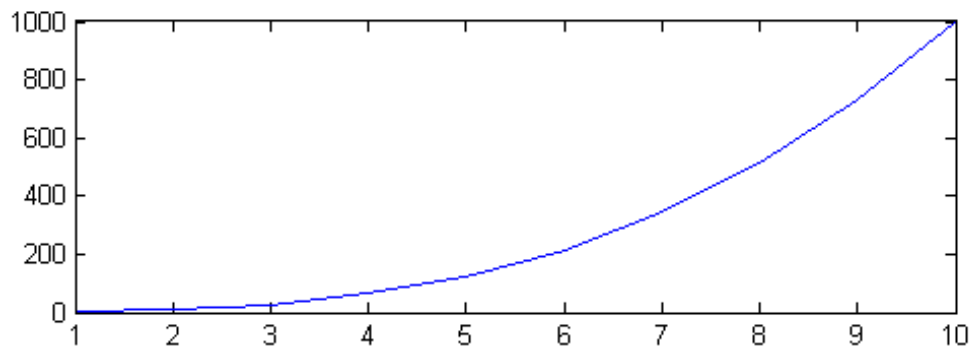
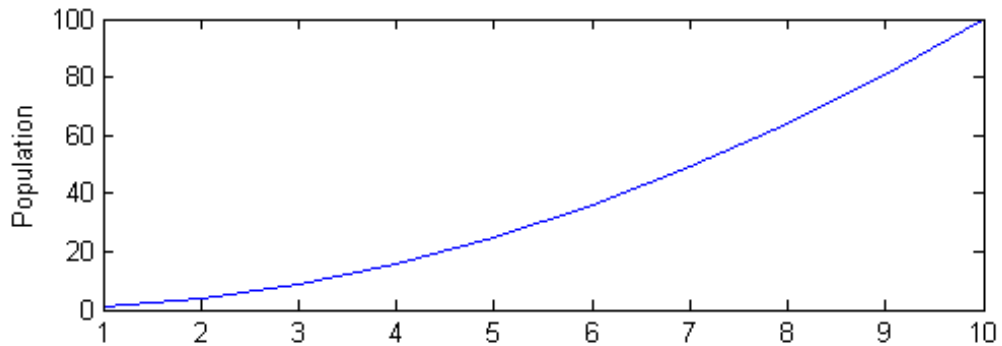

### Label y-Axis and Return Object Handle

Label the  $y$ -axis and return the handle to the text object used as the label.

```
figure
```

# ylabel

---

```
plot((1:10).^2)
str = 'Population';
h = ylabel(str);
```

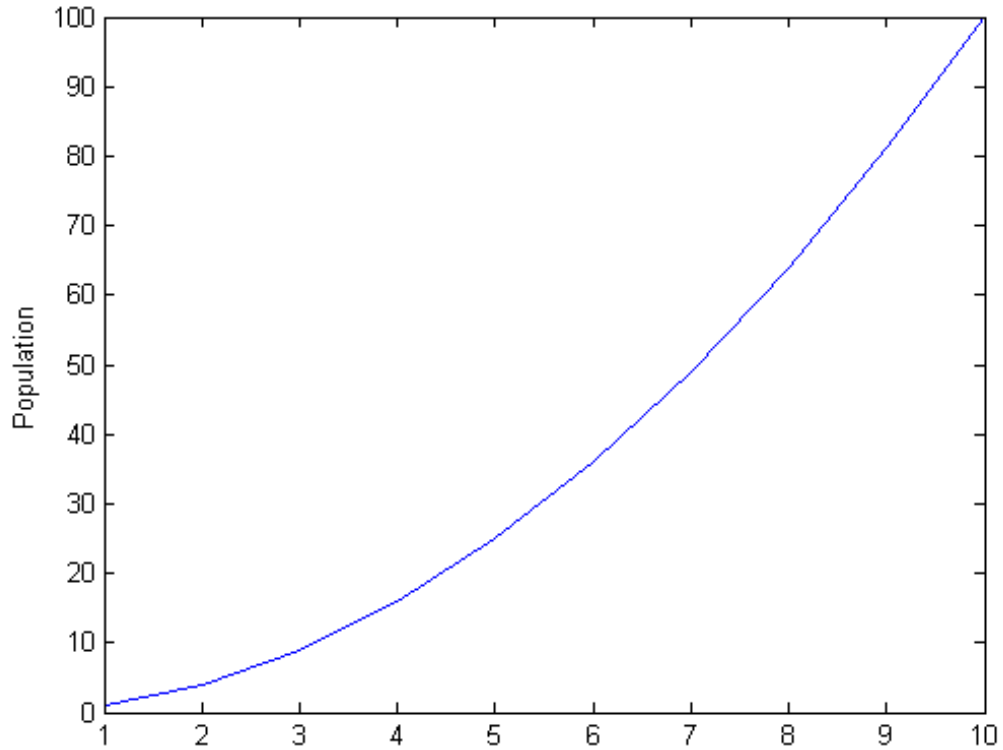

MATLAB® returns the object handle in the output variable, h.  
Set the color of the label to red, using the handle.

```
set(h, 'Color', 'red')
```

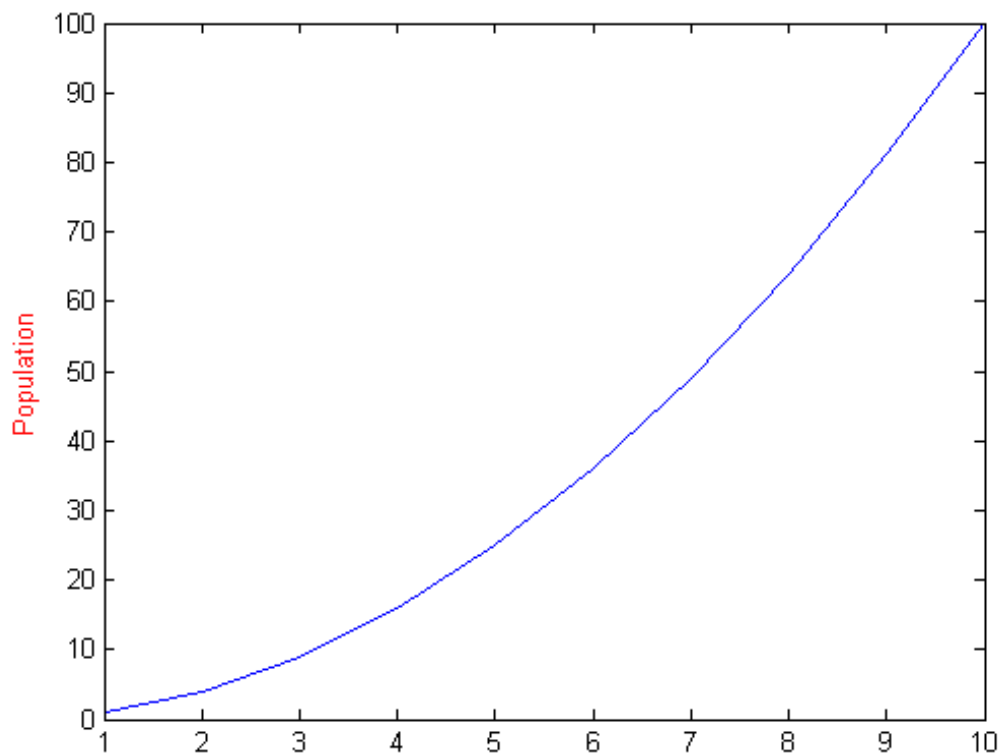
**See Also**

`strings` | `xlabel` | `ylabel` | `zlabel` | `text` | `title`

**Concepts**

- “Add Axis Labels to Graph Using Plot Tools”  
Text Properties

# zlabel

---

## Purpose

Label z-axis

## Syntax

```
zlabel(str)
zlabel(str,Name,Value)

zlabel(axes_handle, ___)

h = zlabel(___)
```

## Description

`zlabel(str)` labels the z-axis of the current axes with the string, `str`. Every axes has one predefined z-axis label. Reissuing the `zlabel` command causes the new label to replace the old label.

`zlabel(str,Name,Value)` additionally specifies the text object properties using one or more `Name,Value` pair arguments.

`zlabel(axes_handle, ___ )` adds the label to the axes specified by `axes_handle`. This syntax allows you to specify the axes to which to add a label. `axes_handle` can precede any of the input argument combinations in the previous syntaxes.

`h = zlabel( ___ )` returns the handle to the text object used as the z-axis label. The handle is useful when making future modifications to the label.

## Input Arguments

### **str - Text to display as z-axis label**

string

Text to display as the z-axis label, specified as a string or the name of a function that returns a string.

**Example:** 'myLabel'

### **axes\_handle - Axes handle**

handle

Axes handle, which is the reference to an axes object. Use the `gca` function to get the handle to the current axes, for example, `axes_handle = gca;`

### Name-Value Pair Arguments

Specify optional comma-separated pairs of `Name`, `Value` arguments. `Name` is the argument name and `Value` is the corresponding value. `Name` must appear inside single quotes ( ' '). You can specify several name and value pair arguments in any order as `Name1,Value1,...,NameN,ValueN`.

**Example:** `'Color','red','FontSize',12` adds an z-axis label with red, 12-point font.

In addition to the following, you can specify other text object properties using `Name`, `Value` pair arguments. See [Text Properties](#).

#### 'Color' - Text color

[0 0 0] (black) (default) | 3-element RGB vector | string

Text color, specified as the comma-separated pair consisting of 'Color' and a 3-element RGB vector or a string containing the short or long name of the color. The RGB vector is a 3-element row vector whose elements specify the intensities of the red, green, and blue components of the color. The intensities must be in the range [0 1].

The following table lists the predefined colors and their RGB equivalents.

RGB Value	Short Name	Long Name
[1 1 0]	y	yellow
[1 0 1]	m	magenta
[0 1 1]	c	cyan
[1 0 0]	r	red
[0 1 0]	g	green
[0 0 1]	b	blue

RGB Value	Short Name	Long Name
[1 1 1]	w	white
[0 0 0]	k	black

Example: 'Color',[0 1 0]

Example: 'Color','green'

### **'FontAngle' - Character slant**

'normal' (default) | 'italic' | 'oblique'

Character slant, specified as the comma-separated pair consisting of 'FontAngle' and one of these values: 'normal', 'italic', or 'oblique'. MATLAB uses the FontAngle property to select a font from those available on your particular system. Generally, setting this property to italic or oblique selects a slanted font.

Example: 'FontAngle','italic'

### **'FontName' - Font name**

'Helvetica' (default) | string | 'FixedWidth'

Font name, specified as the comma-separated pair consisting of 'FontName' and a string. The string specifies the name of the font to use for the text object. To display and print properly, this must be a font that your system supports.

To use a fixed-width font that looks good in any locale, use the case-sensitive string 'FixedWidth'. This eliminates the need to hard-code the name of a fixed-width font, which might not display text properly on systems that do not use ASCII character encoding.

Example: 'FontName','Courier'

### **'FontSize' - Font size**

10 points (default) | scalar

Font size, specified as the comma-separated pair consisting of 'FontSize' and a scalar in units determined by the FontUnits property. The default value for FontUnits is points.

**Example:** 'FontSize',12.5

#### 'FontUnits' - Font size units

'points' (default) | 'normalized' | 'inches' | 'centimeters' | 'pixels'

Font size units, specified as the comma-separated pair consisting of 'FontUnits' and one of the following strings:

- 'points'
- 'normalized'
- 'inches'
- 'centimeters'
- 'pixels'

When the value of FontUnits is 'normalized', MATLAB interprets the value of FontSize as a fraction of the height of the parent axes. When you resize the axes, MATLAB modifies the screen FontSize accordingly. points, inches, centimeters, and pixels are absolute units. 1 point =  $1/72$  inch

---

**Note** When setting both the FontSize and the FontUnits, you must set the FontUnits property first so that MATLAB can correctly interpret the specified FontSize. For example, to set the font size to 0.3 inches, call 'FontUnits', 'inches', 'FontSize', 0.3 in the argument list.

---

#### 'FontWeight' - Weight of text characters

'normal' (default) | 'bold' | 'light' | 'demi'

Weight of text characters, specified as the comma-separated pair consisting of 'FontWeight' and one of the following strings:

# zlabel

---

- 'normal'
- 'bold'
- 'light'
- 'demi'

MATLAB uses the `FontWeight` property to select a font from those available on your particular system. Generally, setting this property to 'bold' or 'demi' causes MATLAB to use a bold font.

**Example:** 'FontWeight','bold'

## 'Interpreter' - Character interpretation

'tex' (default) | 'latex' | 'none'

Character interpretation, specified as the comma-separated pair consisting of 'Interpreter' and one of the following strings.

Interpreter value	Result
'tex'	Supports a subset of plain TeX markup language. See the <code>String</code> property for a list of supported TeX instructions.
'latex'	Supports a basic subset of the LaTeX markup language.
'none'	Interprets all characters as literal characters.

**Example:** 'Interpreter','latex'

## Output Arguments

### **h** - Handle to text object used as z-axis label

scalar

Handle to the text object used as the *z*-axis label, returned as a scalar. This is a unique identifier, which you can use to query and modify the properties of the label.



**Examples****Label z-Axis with String**

```
figure
surf(peaks)
zlabel('Height')
```

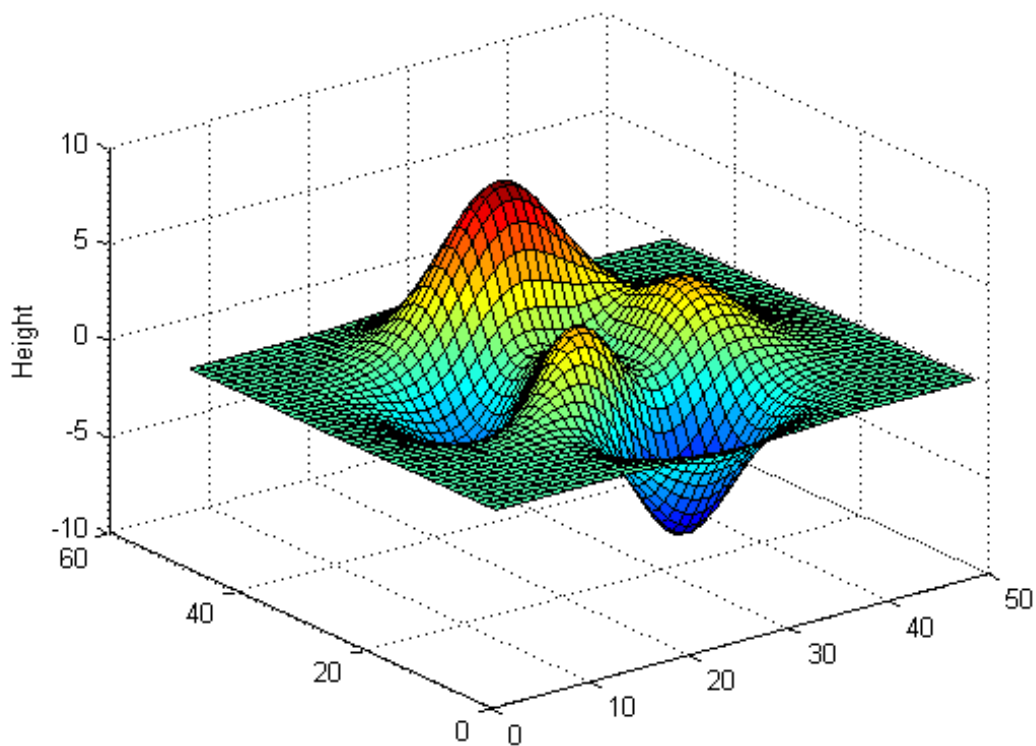

MATLAB® displays Height beside the z-axis.

## Label z-Axis with Numeric Input

```
figure
surf(peaks)
zlabel(123)
```

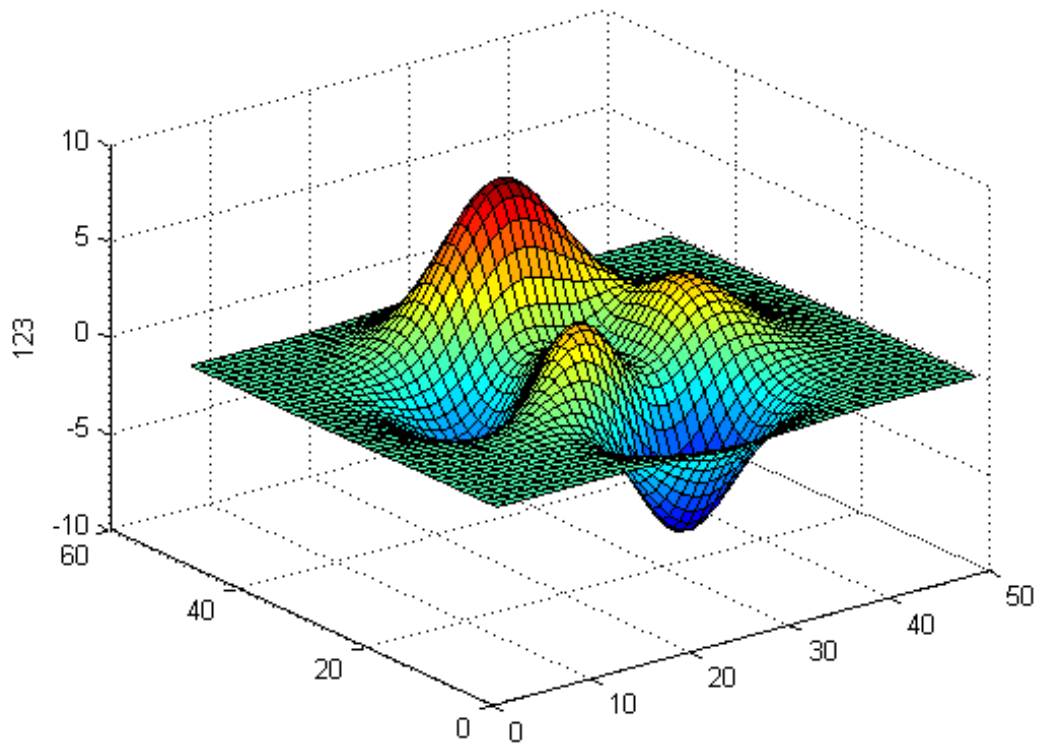

MATLAB® displays 123 beside the z-axis.

### Create Multiline z-Axis Label

Create a multiline label using a multiline cell array.

```
figure
surf(peaks)
zlabel({'First Line';'Second Line'})
```

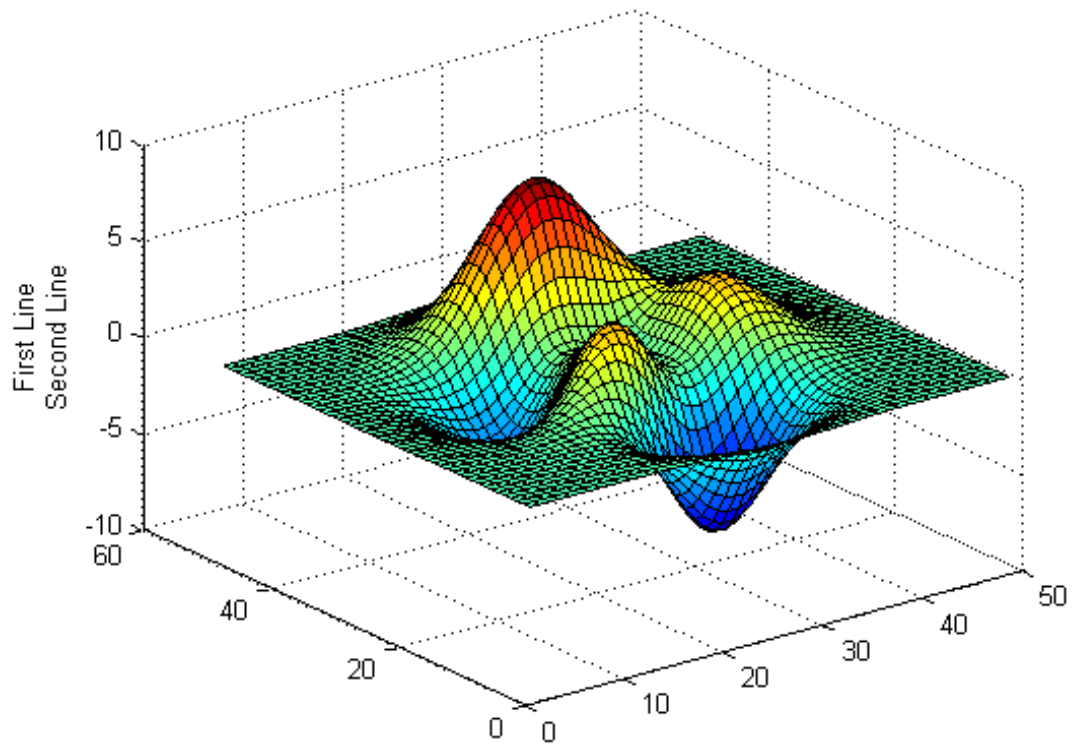

### Label z-Axis and Set Font Properties

Use Name, Value pairs to set the font size, font weight, and text color properties of the z-axis label.

```
figure
```

# zlabel

---

```
surf(peaks)
zlabel('Elevation','FontSize',12,...
 'FontWeight','bold','Color','r');
```

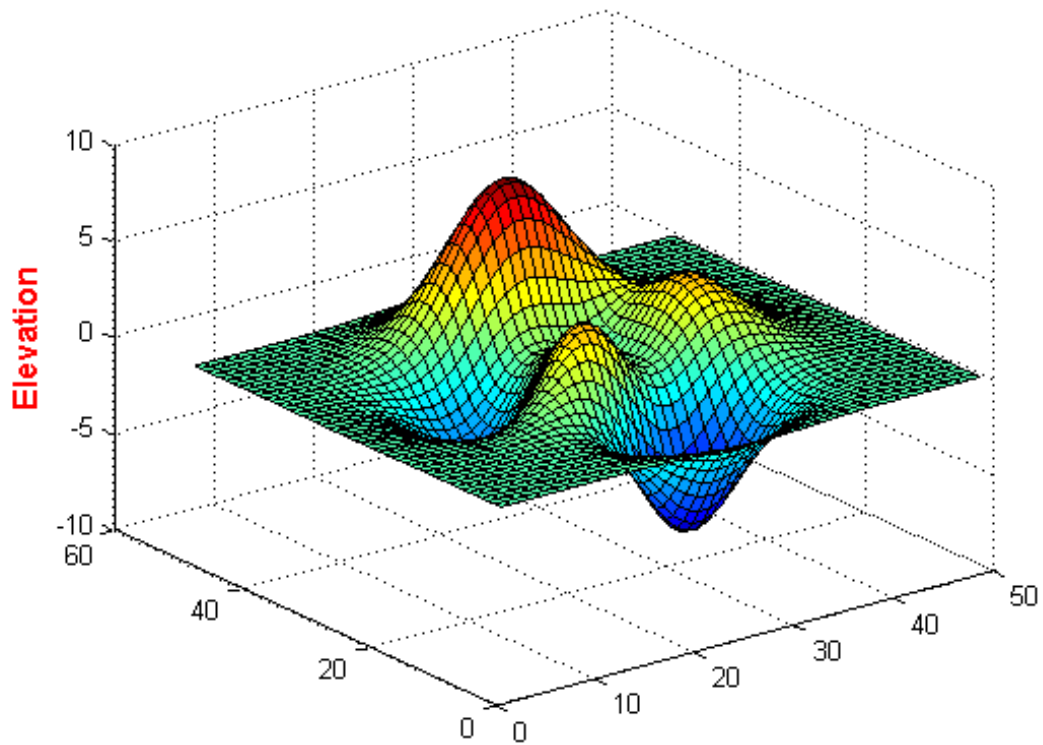

'FontSize',12 displays the label text in 12-point font.  
'FontWeight','bold' makes the text bold. 'Color','r' sets the text color to red.

### **Label z-Axis of Specific Axes**

Create two subplots and return the handles to the axes objects, `s(1)` and `s(2)`.

```
figure
s(1) = subplot(2,1,1);
surf(peaks(30))
s(2) = subplot(2,1,2);
surf(peaks(45))
```

# zlabel

---

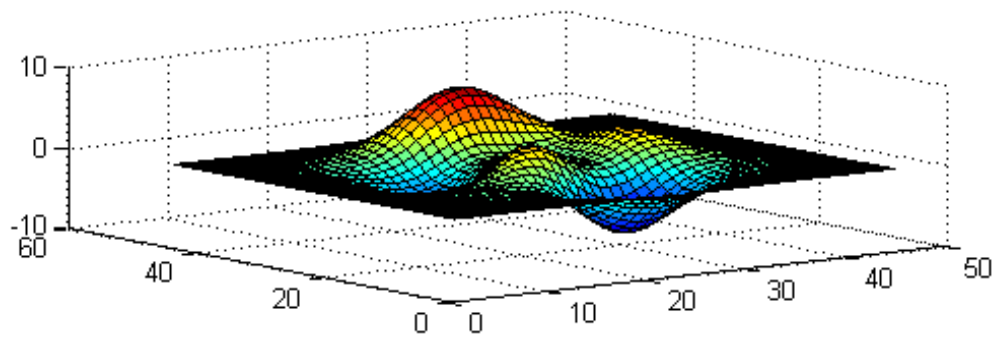
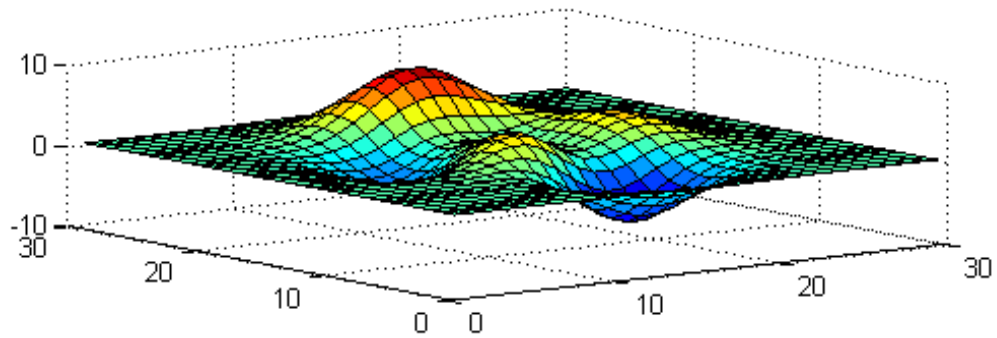

Label the z-axis of each plot by referring to the axes handles, `s(1)` and `s(2)`.

```
zlabel(s(1), 'Height1')
zlabel(s(2), 'Height2')
```

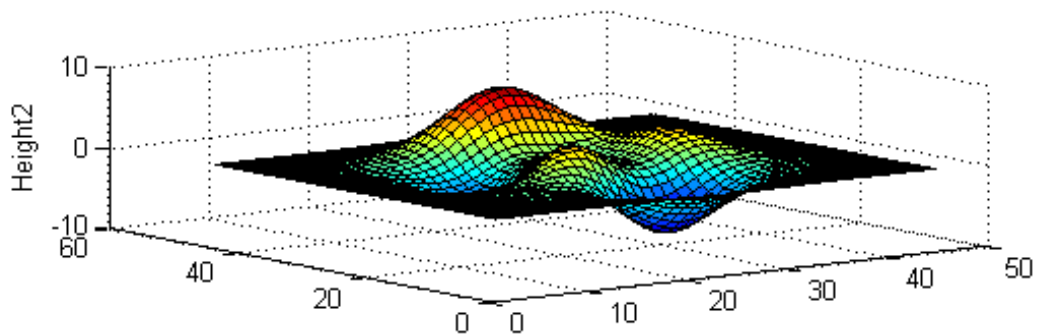
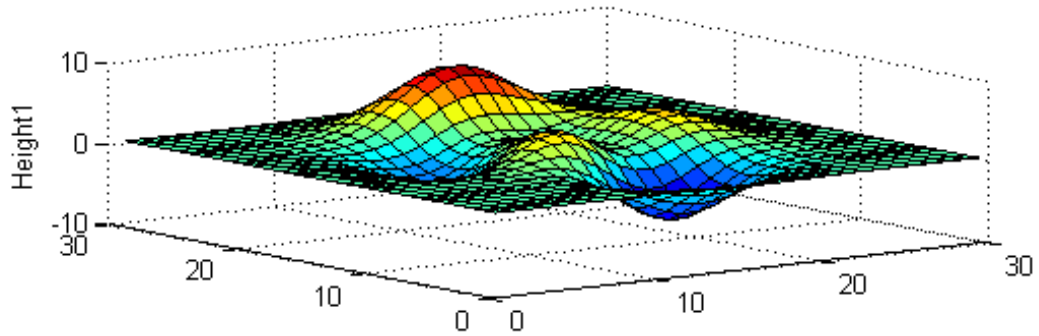

### Label z-Axis and Return Object Handle

Label the  $z$ -axis and return the handle to the text object used as the label.

```
figure
surf(peaks)
str = 'Population Change';
h = zlabel(str);
```

# zlabel

---

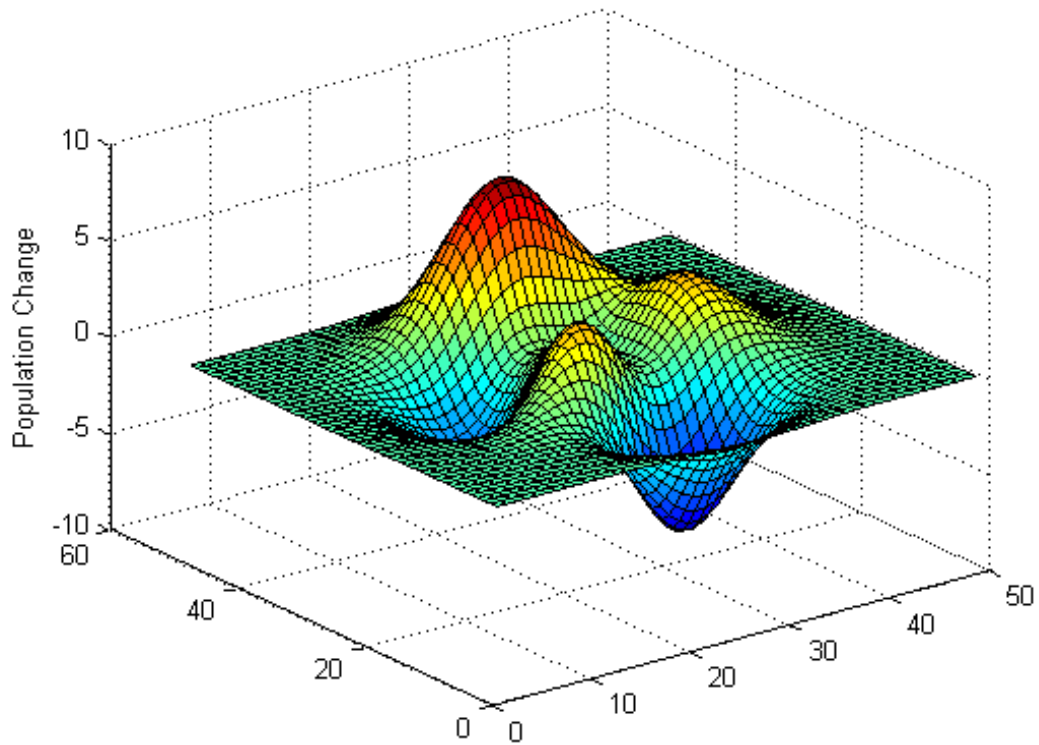

MATLAB® returns the object handle in the output variable, `h`.  
Set the color of the label to red, using the handle.

```
set(h,'Color','red')
```



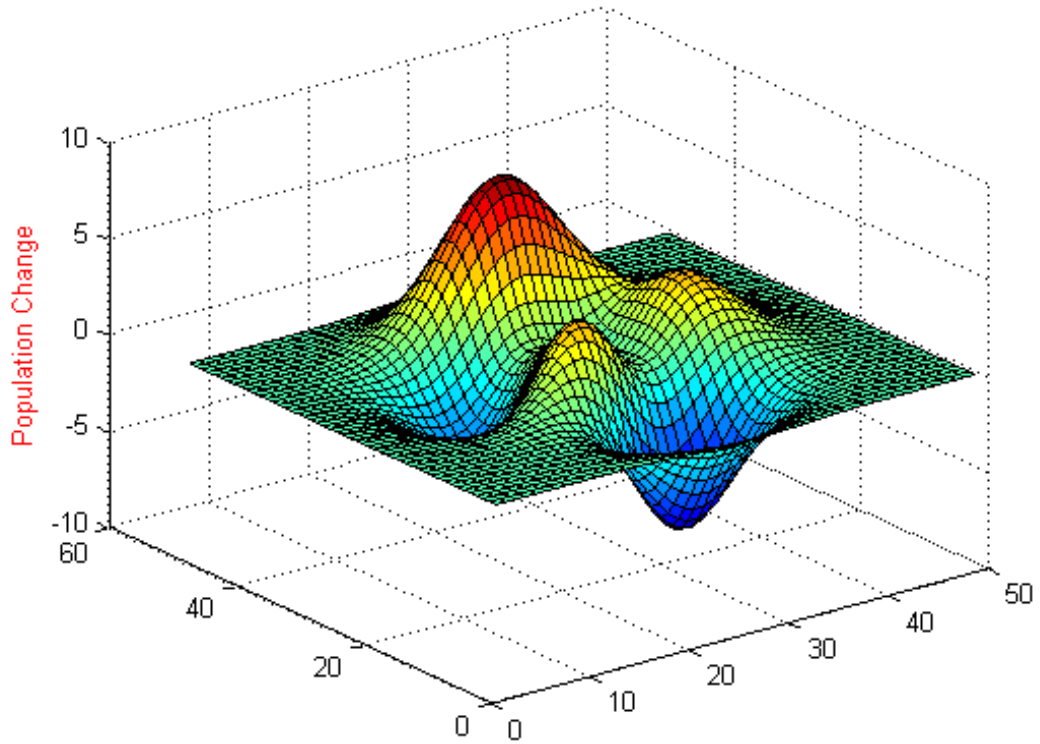

**See Also**

strings | ylabel | xlabel | text | title

**Concepts**

- “Add Axis Labels to Graph Using Plot Tools”  
Text Properties

**Purpose** Set or query  $x$ -axis limits

**Syntax**

```
xlim
xlim([xmin xmax])
xlim('mode')
xlim('auto')
xlim('manual')
xlim(axes_handle,...)
```

**Description**

`xlim` with no arguments returns the limits of the current axes.

`xlim([xmin xmax])` sets the axis limits in the current axes to the specified values.

`xlim('mode')` returns the current value of the axis limits mode, which can be either `auto` (the default) or `manual`.

`xlim('auto')` sets the axis limit mode to `auto`.

`xlim('manual')` sets the axis limit mode to `manual`.

`xlim(axes_handle,...)` performs the set or query on the axes identified by the first argument, `axes_handle`. When you do not specify an axes handle, it operates on the current axes.

**Tips**

`xlim` sets or queries values of the axes object `XLim`, and `XLimMode` property.

When the axis limit mode is set to `auto` (the default), MATLAB uses limits, which are round numbers, to span the range of the data being displayed. Setting a value for any of the limits also sets the corresponding mode to `manual`. If you set the limits on an existing graph and want to maintain these limits while adding more graphs, use the `hold` command.

---

**Note** High-level plotting functions like `plot` and `surf` reset both the modes and the limits.

---

**Examples****Specify Axis Limits**

Set the  $x$ -axis and  $y$ -axis limits to match the range of data.

```
[x,y] = meshgrid(-1.75:.2:3.25);
z = x.*exp(-x.^2-y.^2);
```

```
figure
surf(x,y,z)
xlim([-1.75,3.25])
ylim([-1.75,3.25])
```

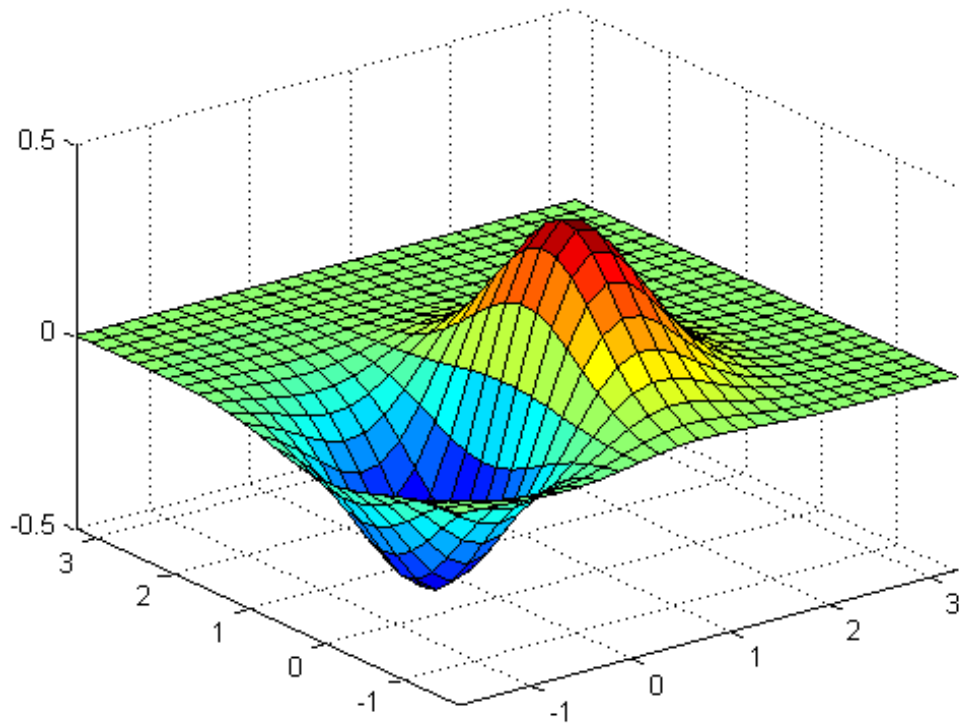

## Alternatives

To control the upper and lower axis limits on a graph, use the Property Editor, one of the plotting tools . For details, see The Property Editor.

## See Also

`ylim` | `zlim` | `axis`

**How To**

- XLim
- YLim
- ZLim
- Understanding Axes Aspect Ratio

**Purpose** Set or query *y*-axis limits

**Syntax**

```
ylim
ylim([ymin ymax])
ylim('mode')
ylim('auto')
ylim('manual')
ylim(axes_handle,...)
```

**Description**

`ylim` with no arguments returns the limits of the current axes.

`ylim([ymin ymax])` sets the axis limits in the current axes to the specified values.

`ylim('mode')` returns the current value of the axis limits mode, which can be either `auto` (the default) or `manual`.

`ylim('auto')` sets the axis limit mode to `auto`.

`ylim('manual')` sets the axis limit mode to `manual`.

`ylim(axes_handle,...)` performs the set or query on the axes identified by the first argument, `axes_handle`. When you do not specify an axes handle, it operates on the current axes.

**Tips**

`ylim` sets or queries values of the axes object `YLim` and `YLimMode` property.

When the axis limit mode is set to `auto` (the default), MATLAB uses limits, which are round numbers, to span the range of the data being displayed. Setting a value for any of the limits also sets the corresponding mode to `manual`. If you set the limits on an existing graph and want to maintain these limits while adding more graphs, use the `hold` command.

---

**Note** High-level plotting functions like `plot` and `surf` reset both the modes and the limits.

---

## Examples

### Specify Axis Limits

Set the  $x$ -axis and  $y$ -axis limits to match the range of data.

```
[x,y] = meshgrid(-1.75:.2:3.25);
z = x.*exp(-x.^2-y.^2);
```

```
figure
surf(x,y,z)
xlim([-1.75,3.25])
ylim([-1.75,3.25])
```

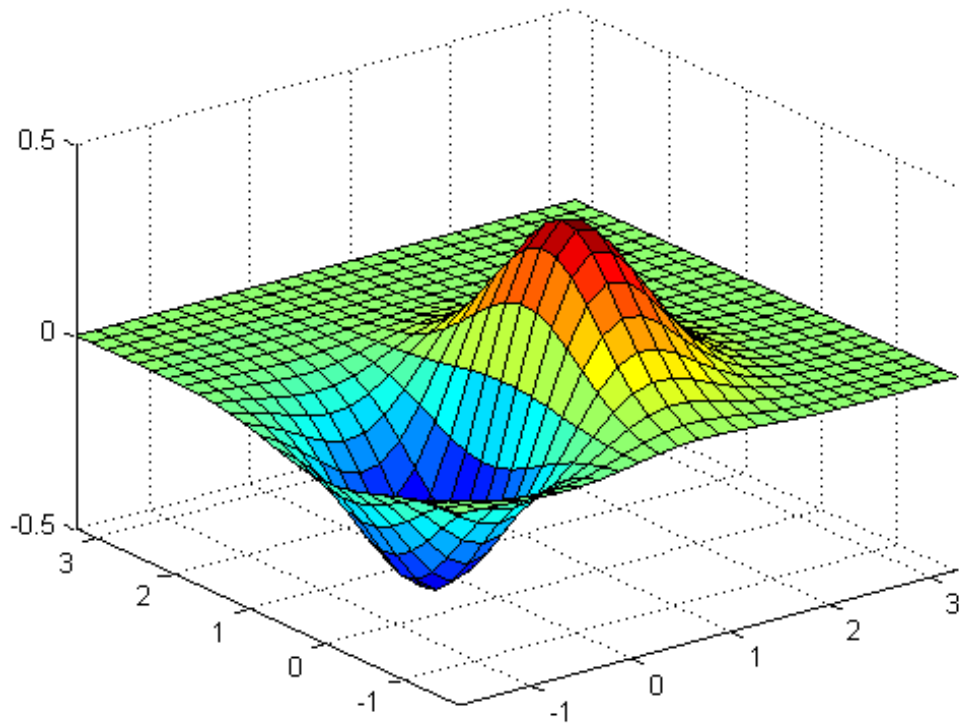

## Alternatives

To control the upper and lower axis limits on a graph, use the Property Editor, one of the plotting tools . For details, see The Property Editor.

## See Also

`xlim` | `zlim` | `axis`



**How To**

- XLim
- YLim
- ZLim
- Understanding Axes Aspect Ratio

# zlim

---

**Purpose** Set or query z-axis limits

**Syntax**

```
zlim
zlim([zmin zmax])
zlim('mode')
zlim('auto')
zlim('manual')
zlim(axes_handle,...)
```

**Description**

`zlim` with no arguments returns the limits of the current axes.

`zlim([zmin zmax])` sets the axis limits in the current axes to the specified values.

`zlim('mode')` returns the current value of the axis limits mode, which can be either `auto` (the default) or `manual`.

`zlim('auto')` sets the axis limit mode to `auto`.

`zlim('manual')` sets the axis limit mode to `manual`.

`zlim(axes_handle,...)` performs the set or query on the axes identified by the first argument, `axes_handle`. When you do not specify an axes handle, it operates on the current axes.

**Tips**

`zlim` sets or queries values of the axes object `ZLim` and `ZLimMode` property.

When the axis limit mode is set to `auto` (the default), MATLAB uses limits, which are round numbers, to span the range of the data being displayed. Setting a value for any of the limits also sets the corresponding mode to `manual`. If you set the limits on an existing graph and want to maintain these limits while adding more graphs, use the `hold` command.

---

**Note** High-level plotting functions like `plot` and `surf` reset both the modes and the limits.

---

## Examples Specify z-Axis Limits

Specify the z-axis limits for the graph.

```
[x,y] = meshgrid([-1.75:.2:3.25]);
z = x.*exp(-x.^2-y.^2);
```

```
figure
surf(x,y,z)
zlim([-0.35,0.3])
```

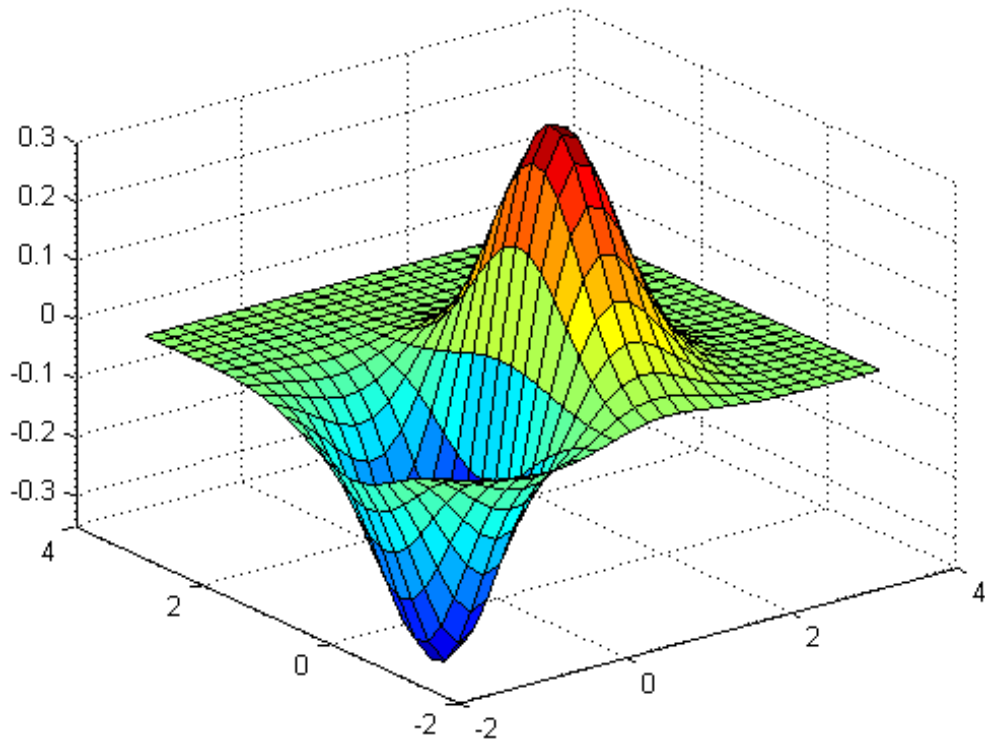

# zlim

---

**Alternatives** To control the upper and lower axis limits on a graph, use the Property Editor, one of the plotting tools . For details, see The Property Editor.

**See Also** `xlim` | `ylim` | `axis`

- How To**
- `XLim`
  - `YLim`
  - `ZLim`
  - Understanding Axes Aspect Ratio

<b>Purpose</b>	Determine if file contains Microsoft Excel spreadsheet
<b>Syntax</b>	<pre>status = xlsfinfo(filename) [status,sheets] = xlsfinfo(filename) [status,sheets,xlFormat] = xlsfinfo(filename)</pre>
<b>Description</b>	<p><code>status = xlsfinfo(filename)</code> indicates if <code>filename</code> is a file that the <code>xlsread</code> function can read.</p> <p><code>[status,sheets] = xlsfinfo(filename)</code> additionally returns the name of each spreadsheet in the file.</p> <p><code>[status,sheets,xlFormat] = xlsfinfo(filename)</code> also returns the format description that Excel returns for the file. On systems without Excel for Windows, <code>xlFormat</code> is an empty string, <code>''</code>.</p>
<b>Input Arguments</b>	<p><b>filename - Name of file</b> string Name of file, specified as a string. <b>Example:</b> <code>'myFile.xlsx'</code></p> <p><b>Data Types</b> char</p>
<b>Output Arguments</b>	<p><b>status - Type of file</b> string Type of file, returned as a string.</p> <ul style="list-style-type: none"><li>• If <code>filename</code> is a file that <code>xlsread</code> can read, then <code>status</code> is a descriptive string, such as <code>'Microsoft Excel Spreadsheet'</code>.</li><li>• If <code>filename</code> is not a file that <code>xlsread</code> can read, then <code>status</code> is an empty string, <code>''</code>.</li><li>• If MATLAB cannot find the file, then <code>xlsfinfo</code> returns an error.</li></ul>

## **sheets - Worksheet names**

1-by-n cell array of strings

Worksheet names, returned as a 1-by-n cell array of strings, where n is the number of worksheets in the file. Each cell contains the name of a worksheet. If `xlsread` cannot read a particular worksheet, the corresponding cell contains an error message.

If `xlsfinfo` cannot read the file, then `sheets` contains an error message.

## **xlFormat - File format description returned by Excel**

string

File format description returned by Excel, returned as a string.

On Windows systems with Excel software, `xlFormat` is a nonempty string, such as one of the following.

'xlOpenXMLWorkbook'	Spreadsheet in XLSX format (Excel 2007 or later)
'xlWorkbookNormal' or 'xlExce18'	Spreadsheet in XLS format (compatible with Excel 97-2003)
'xlCSV'	File in comma-separated value (CSV) format
'xlHtml' or 'xlWebArchive'	Spreadsheet exported to HTML format

On all other systems, `xlFormat` is an empty string, ''.

## **Examples**

### **View Information About Spreadsheet File**

Create a sample Excel file named `myExample.xlsx`.

```
values = {1, 2, 3 ; 4, 5, 'x' ; 7, 8, 9};
headers = {'First', 'Second', 'Third'};
xlswrite('myExample.xlsx', [headers; values]);
```

Call `xlsfinfo` to get information about the file.

```
[status,sheets,xlFormat] = xlsfinfo('myExample.xlsx')
```

```
status =
```

```
Microsoft Excel Spreadsheet
```

```
sheets =
```

```
 'Sheet1' 'Sheet2' 'Sheet3'
```

```
xlFormat =
```

```
xlOpenXMLWorkbook
```

`status` is a descriptive string indicating that the `xlsread` function can read the sample file.

## Tips

- If `xlsfinfo` warns that it cannot start an ActiveX server, then the COM server, which is part of the typical Excel installation, is unavailable. In this case, consider reinstalling your Excel software. On systems with Excel for Windows, `xlsfinfo` uses the COM server to obtain information.

## Limitations

- `xlsfinfo` supports only 7-bit ASCII characters.

## See Also

`xlsread` | `xlswrite`

# xlsread

---

**Purpose** Read Microsoft Excel spreadsheet file

**Syntax**

```
num = xlsread(filename)
num = xlsread(filename, sheet)
num = xlsread(filename, xlRange)
num = xlsread(filename, sheet, xlRange)
num = xlsread(filename, sheet, xlRange, 'basic')
[num, txt, raw] = xlsread(___)

___ = xlsread(filename, -1)
```

```
[num, txt, raw, custom] = xlsread(filename, sheet, xlRange, '',
 functionHandle)
```

**Description** `num = xlsread(filename)` reads data from the first worksheet in the Microsoft Excel spreadsheet file named `filename` and returns the numeric data in array `num`.

On Windows systems with Microsoft Excel software, `xlsread` reads any file format recognized by your version of Excel.

If your system does not have Excel for Windows, `xlsread` operates in basic import mode, and reads only XLS, XLSX, XLSM, XLTX, and XLTM files.

`num = xlsread(filename, sheet)` reads the specified worksheet.

`num = xlsread(filename, xlRange)` reads data from the specified range, `xlRange`, of the first worksheet in the file.

`num = xlsread(filename, sheet, xlRange)` reads from the specified sheet and range, `xlRange`.

`num = xlsread(filename, sheet, xlRange, 'basic')` reads data from the spreadsheet in basic mode, the default on systems without Excel for



Windows. If you do not specify all the arguments, use empty strings as placeholders, for example, `num = xlsread(filename, '', '', 'basic')`.

`[num,txt,row] = xlsread( ___ )` additionally returns the text fields in cell array `txt`, and the unprocessed data (numbers and text) in cell array `raw` using any of the input arguments in the previous syntaxes. If `xlRange` is specified, leading blank rows and columns in the worksheet that precede rows and columns with data are returned in `raw`.

`___ = xlsread(filename, -1)` opens an Excel window to interactively select data. Select the worksheet, drag and drop the mouse over the range you want, and click **OK**. This syntax is supported only on Windows systems with Excel software.

`[num,txt,row,custom] = xlsread(filename, sheet, xlRange, '', functionHandle)` reads from the spreadsheet, executes the function associated with `functionHandle` on the data, and returns the final results as numeric data in array `num`. The `xlsread` function optionally returns the text fields in cell array `txt`, the unprocessed data (numbers and text) in cell array `raw`, and the second output from the function associated with `functionHandle` in array `custom`. The `xlsread` function does not change the data stored in the spreadsheet. This syntax is supported only on Windows systems with Excel software.

## Input Arguments

### **filename - Name of file to read**

string

Name of the file to read, specified as a string. If you do not include an extension, `xlsread` searches for a file with the specified name and a supported Excel extension. `xlsread` can read data saved in files that are currently open in Excel for Windows.

**Example:** `'myFile.xlsx'`

### **Data Types**

char

## **sheet - Worksheet to read**

string | positive integer

Worksheet to read, specified as one of the following:

- String that contains the worksheet name. Cannot contain a colon (:). To determine the names of the sheets in a spreadsheet file, use `xlsfinfo`. For XLS files in `basic` mode, `sheet` is case sensitive.
- Positive integer that indicates the worksheet index. Not supported for XLS files in `basic` mode.

## **xlRange - Rectangular portion of the worksheet to read**

string

Rectangular portion of the worksheet to read, specified as a string.

Specify `xlRange` using the syntax '`C1:C2`', where `C1` and `C2` are two opposing corners that define the region to read. For example, '`D2:H4`' represents the 3-by-5 rectangular region between the two corners `D2` and `H4` on the worksheet. The `xlRange` input is not case sensitive, and uses Excel A1 reference style (see Excel help).

Range selection is not supported when reading XLS files in `basic` mode. In this case, use `' '` in place of `xlRange`.

If you do not specify `sheet`, then `xlRange` must include both corners and a colon character, even for a single cell (such as '`D2:D2`'). Otherwise, `xlsread` interprets the input as a worksheet name (such as '`sales`' or '`D2`').

If you specify `sheet`, then `xlRange`:

- Does not need to include a colon and opposite corner to describe a single cell.
- Can refer to a named range that you defined in the Excel file (see the Excel help).

## **Data Types**

char

**'basic' - Flag to request reading in basic mode**

literal string

Flag to request reading in basic mode, specified as the literal string, 'basic'.

basic mode is the default for systems without Excel for Windows. In basic mode, xlsread:

- Reads XLS, XLSX, XLSM, XLTX, and XLTM files only.
- Does not support an x1Range input when reading XLS files. In this case, use '' in place of x1Range.
- Does not support function handle inputs.
- Imports all dates as Excel serial date numbers. Excel serial date numbers use a different reference date than MATLAB date numbers.

**functionHandle - Handle to a custom function**

function handle

Handle to a custom function, starting with the symbol @. Supported only on Windows systems with Excel software. xlsread reads from the spreadsheet, executes your function on a copy of the data, and returns the final results. xlsread does not change the data stored in the spreadsheet.

When xlsread calls the custom function, it passes a range interface from the Excel application to provide access to the data. The custom function must include this interface both as an input and output argument. (See the Examples.)

**Example:** @myFunctionHandle

**Output Arguments****num - Numeric data**

matrix

Numeric data, returned as a matrix of double values. The array does not contain any information from header lines, or from outer rows or columns that contain nonnumeric data. Text data in inner spreadsheet rows and columns appear as NaN in the num output.

## **txt - Text data**

cell array

Text data, returned as a cell array. Numeric values in inner spreadsheet rows and columns appear as empty strings, '', in txt.

For XLS files in basic import mode, the txt output contains empty strings, '', in place of leading columns of numeric data that precede text data in the spreadsheet. In all other cases, txt does not contain these additional columns.

Undefined values (such as '#N/A') appear in the txt output as '#N/A', except for XLS files in basic mode.

## **raw - Unprocessed data**

cell array

Unprocessed data from the worksheet, returned as a cell array. Contains both numeric and text data.

On systems with Excel for Windows, undefined values (such as '#N/A') appear in the raw output as 'ActiveX\_VT\_ERROR:'. For XLSX, XLSM, XLTX, and XLTM files on other systems, undefined values appear as '#N/A'.

## **custom - Second output of the function corresponding to functionHandle**

defined by the function

Second output of the function corresponding to functionHandle. The value and data type of custom are determined by the function.

## **Examples**

### **Read Data from First Worksheet Into Numeric Array**

Create an Excel file named myExample.xlsx.

```
values = {1, 2, 3 ; 4, 5, 'x' ; 7, 8, 9};
headers = {'First', 'Second', 'Third'};
xlswrite('myExample.xlsx', [headers; values]);
```

Sheet1 of myExample.xlsx contains:

First	Second	Third
1	2	3
4	5	x
7	8	9

Read data from the first worksheet.

```
filename = 'myExample.xlsx';
A = xlsread(filename)
```

```
A =
 1 2 3
 4 5 NaN
 7 8 9
```

xlsread returns the numeric data in array A.

### Read a Specific Range of Data

Read a specific range of data from the Excel file in the previous example.

```
filename = 'myExample.xlsx';
sheet = 1;
xlRange = 'B2:C3';
```

```
subsetA = xlsread(filename, sheet, xlRange)
```

```
subsetA =
 2 3
 5 NaN
```

### Read a Column of Data

Read the second column of data from the Excel file in the first example.

```
filename = 'myExample.xlsx';

columnB = xlsread(filename, 'B:B')
```

```
columnB =
 2
 5
 8
```

For better performance, specify the row numbers in the range, as shown in the previous example.

## Request Numeric, Text, and Unprocessed Data

Request the numeric data, text, and a copy of the unprocessed (raw) data from the Excel file in the first example.

```
[ndata, text, alldata] = xlsread('myExample.xlsx')
```

```
ndata =
 1 2 3
 4 5 NaN
 7 8 9
```

```
text =
 'First' 'Second' 'Third'
 '' '' ''
 '' '' 'x'
```

```
alldata =
 'First' 'Second' 'Third'
 [1] [2] [3]
 [4] [5] 'x'
 [7] [8] [9]
```

`xlsread` returns numeric data in array `ndata`, text data in cell array `text`, and unprocessed data in cell array `alldata`.

## Execute a Function on a Worksheet and Return Numeric Data

In the Editor, create a function to process data from a worksheet. In this case, set values outside the range [-3, 3] to -3 or 3.

```
function [Data] = setMinMax(Data)

 minval = -3; maxval = 3;

 for k = 1:Data.Count
 v = Data.Value{k};
 if v > maxval || v < minval
 if v > maxval
 Data.Value{k} = maxval;
 else
 Data.Value{k} = minval;
 end
 end
 end
end
```

In the Command Window, add data to myExample.xlsx.

```
misc = pi*gallery('normaldata',[10,3],1);
xlswrite('myExample.xlsx',misc,'MyData');
```

Worksheet MyData contains the following values, which range from -6.6493 to 3.4845:

2.7156	-6.1744	1.8064
0.2959	-2.3383	-2.7210
-2.6764	-1.7351	-6.6493
2.7442	-2.5752	-3.0300
-1.3761	3.4845	0.6683
-1.3498	-1.9319	1.5014
-3.4643	-0.8000	0.3162
1.2448	-0.8477	0.9344
-3.0314	-5.2527	1.7912
0.5292	-5.8938	-5.1035

Read the data from the worksheet, and reset any values outside the range [-3, 3]. Specify the sheet name, but use '' as placeholders for the xlRange and 'basic' inputs.

```
trim = xlsread('myExample.xlsx','MyData','','',@setMinMax)
```

```
trim =
 2.7156 -3.0000 1.8064
 0.2959 -2.3383 -2.7210
 -2.6764 -1.7351 -3.0000
 2.7442 -2.5752 -3.0000
 -1.3761 3.0000 0.6683
 -1.3498 -1.9319 1.5014
 -3.0000 -0.8000 0.3162
 1.2448 -0.8477 0.9344
 -3.0000 -3.0000 1.7912
 0.5292 -3.0000 -3.0000
```

## Request Custom Output

Execute a function on a worksheet and display the custom index output.

In the Editor, modify the function `setMinMax` from the previous example to return the indices of the changed elements (custom output).

```
function [Data,indices] = setMinMax(Data)

 minval = -3; maxval = 3;
 indices = [];

 for k = 1:Data.Count
 v = Data.Value{k};
 if v > maxval || v < minval
 if v > maxval
 Data.Value{k} = maxval;
 else
 Data.Value{k} = minval;
 end
 indices = [indices k];
 end
 end
```



Read the data from the worksheet MyData, and request the custom index output, idx.

```
[trim,txt,row,idx] = xlsread('myExample.xlsx',...
'MyData','', '@setMinMax);
disp(idx)
```

```
7 9 11 15 19 20 23 24 30
```

## Algorithms

- If you do not specify `xlRange`, then `xlsread` ignores leading blank rows and columns in the worksheet that precede your data.
- If you specify `xlRange`, then leading blank rows and columns in the worksheet that precede your data are returned in `row`, but not in `num` or `txt`.
- When the specified `xlRange` overlaps merged cells:
  - On Windows systems with Excel, `xlsread` expands the range to include all merged cells.
  - On systems without Excel for Windows, `xlsread` returns data for the specified range only, with empty or NaN values for merged cells.
- `xlsread` imports formatted dates as strings (such as '10/31/96'), except in `basic` mode and on systems without Excel for Windows.

## Limitations

- `xlsread` reads only 7-bit ASCII characters.
- `xlsread` does not support non-contiguous ranges.

## See Also

`xlswrite` | `xlsfinfo` | `importdata` | `uiimport` | `readtable` | `function_handle`

## Concepts

- “When to Convert Dates from Excel Files”

# xlswrite

---

## Purpose

Write Microsoft Excel spreadsheet file

## Syntax

```
xlswrite(filename,A)
xlswrite(filename,A,sheet)
xlswrite(filename,A,xlRange)
xlswrite(filename,A,sheet,xlRange)
```

```
status = xlswrite(___)
[status,message] = xlswrite(___)
```

## Description

`xlswrite(filename,A)` writes array `A` to the first worksheet in Excel file, `filename`, starting at cell `A1`.

`xlswrite(filename,A,sheet)` writes to the specified worksheet.

`xlswrite(filename,A,xlRange)` writes to the rectangular region specified by `xlRange` in the first worksheet of the file.

`xlswrite(filename,A,sheet,xlRange)` writes to the specified sheet and range, `xlRange`.

`status = xlswrite( ___ )` returns the status of the write operation, and can include any of the input arguments in previous syntaxes. When the operation is successful, `status` is 1. Otherwise, `status` is 0.

`[status,message] = xlswrite( ___ )` additionally returns any warning or error message generated by the write operation in structure `message`.

## Input Arguments

**filename - Name of file to write**

string

Name of file to write, specified as a string.

If `filename` does not exist, `xlswrite` creates a file, determining the format based on the specified extension. To create a file compatible with Excel 97-2003 software, specify an extension of `.xls`. To create files in Excel 2007 formats, specify an extension of `.xlsx`, `.xlsb`, or `.xlsm`. If you do not specify an extension, `xlswrite` uses the default, `.xls`.

**Example:** `'myFile.xlsx'`

## **A - Data to write**

`matrix` | `cell array`

Data to write, specified as a two-dimensional numeric or character array, or, if each cell contains a single element, a cell array.

If `A` is a cell array containing something other than a scalar numeric or a string, then `xlswrite` silently leaves the corresponding cell in the spreadsheet empty.

The maximum size of array `A` depends on the associated Excel version. For more information on Excel specifications and limits, see the Excel help.

**Example:** `[10,2,45;-32,478,50]`

**Example:** `{92.0,'Yes',45.9,'No'}`

## **Data Types**

`single` | `double` | `int8` | `int16` | `int32` | `int64` | `uint8` | `uint16` | `uint32` | `uint64` | `logical` | `char` | `cell`

## **sheet - Worksheet name**

`string` | `positive integer`

Worksheet name, specified as one of the following:

- String that contains the worksheet name. Cannot contain a colon (:). To determine the names of the sheets in a spreadsheet file, use `xlsfinfo`.
- Positive integer that indicates the worksheet index.

# xlswrite

---

If `sheet` does not exist, `xlswrite` adds a new sheet at the end of the worksheet collection. If `sheet` is an index larger than the number of worksheets, `xlswrite` appends empty sheets until the number of worksheets in the workbook equals `sheet`. In either case, `xlswrite` generates a warning indicating that it has added a new worksheet.

## **xlRange - Rectangular portion of the worksheet to write**

string

Rectangular portion of the worksheet to write, specified as a string.

Specify `xlRange` using the syntax '`C1:C2`', where `C1` and `C2` are two opposing corners that define the region to write. For example, '`D2:H4`' represents the 3-by-5 rectangular region between the two corners `D2` and `H4` on the worksheet. The `xlRange` input is not case sensitive, and uses Excel A1 reference style (see Excel help). `xlswrite` does not recognize named ranges.

- If you do not specify `sheet`, then `xlRange` must include both corners and a colon character, even for a single cell (such as '`D2:D2`'). Otherwise, `xlswrite` interprets the input as a worksheet name (such as '`D2`').
- If you specify `sheet`, then `xlRange` can specify only the first cell (such as '`D2`'). `xlswrite` writes input array `A` beginning at this cell.
- If `xlRange` is larger than the size of input array `A`, Excel software fills the remainder of the region with `#N/A`. If `xlRange` is smaller than the size of `A`, then `xlswrite` writes only the subset that fits into `xlRange` to the file.

## **Output Arguments**

### **status - Status of the write operation**

1 | 0

Status of the write operation, returned as either 1 (true) or 0 (false). When the write operation is successful, `status` is 1. Otherwise, `status` is 0.

### **message - Error or warning generated during the write operation**

structure array

Error or warning generated during the write operation, returned as a structure array containing two fields:

**message**        Text of the warning or error message, returned as a string.

**identifier**    Message identifier, returned as a string.

## Examples

### Write Data to a Spreadsheet

Write a 7-element vector to an Excel file, `testdata.xlsx`.

```
filename = 'testdata.xlsx';
A = [12.7, 5.02, -98, 63.9, 0, -.2, 56];
xlswrite(filename,A)
```

### Write Data to a Specific Sheet and Range in a Spreadsheet

Write mixed text and numeric data to an Excel file, `testdata.xlsx`, starting at cell E1 of Sheet2.

```
filename = 'testdata.xlsx';
A = {'Time', 'Temperature'; 12,98; 13,99; 14,97};
sheet = 2;
xlRange = 'E1';
xlswrite(filename,A,sheet,xlRange)
```

## Tips

- If your system has Microsoft Office 2003 software, but you want to create a file in an Excel 2007 format, install the Office 2007 Compatibility Pack.
- Excel and MATLAB can store dates as strings (such as '10/31/96') or serial date numbers (such as 729329). If your array `A` includes serial date numbers, convert the dates to strings using `datestr` before calling `xlswrite`. Alternatively, see “When to Convert Dates from Excel Files”.

# xlswrite

---

- To write data to Excel files with custom formats (such as fonts or colors), access the Windows COM server directly using `actxserver` rather than `xlswrite`. For example, Technical Solution 1-QLD4K uses `actxserver` to establish a connection between MATLAB and Excel, writes data to a worksheet, and specifies the colors of the cells.

## Algorithms

Excel converts `Inf` values to 65535. MATLAB converts `NaN` values to empty cells.

If your system does not have Excel for Windows, or if the COM server (part of the typical installation of Excel) is unavailable, then the `xlswrite` function:

- Writes array `A` to a text file in comma-separated value (CSV) format.
- Ignores the `sheet` and `xlRange` arguments.
- Generates an error when input array `A` is a cell array.

## See Also

`xlsread` | `xlsfinfo` | `writetable`

<b>Purpose</b>	Read XML document and return Document Object Model node
<b>Syntax</b>	<code>DOMnode = xmlread(filename)</code>
<b>Description</b>	<code>DOMnode = xmlread(filename)</code> reads the specified XML file and returns a Document Object Model node representing the document.
<b>Tips</b>	<p>The display for a properly parsed document is <code>[#document: null]</code>. For example,</p> <pre>xDoc = xmlread('info.xml')</pre> <p>returns</p> <pre>xDoc = [#document: null]</pre>
<b>Input Arguments</b>	<p><b>filename</b></p> <p>String enclosed in single quotation marks that specifies the name of the local file or URL.</p>
<b>Output Arguments</b>	<p><b>DOMnode</b></p> <p>Document Object Model node, as defined by the World Wide Web consortium. For more information, see “What Is an XML Document Object Model (DOM)?”.</p>
<b>Examples</b>	<p>The root element in an XML file sometimes includes an <code>xsi:noNamespaceSchemaLocation</code> attribute. The value of this attribute is the name of the preferred schema file. Call the <code>getAttribute</code> method to get this value:</p> <pre>xDoc = xmlread(fullfile(matlabroot,'toolbox',...                         'matlab','general','info.xml'));  xRoot = xDoc.getDocumentElement; schema = char(xRoot.getAttribute('xsi:noNamespaceSchemaLocation'))</pre>

This code returns:

```
schema =
http://www.mathworks.com/namespace/info/v1/info.xsd
```

---

Create functions that parse data from an XML file into a MATLAB structure array with fields Name, Attributes, Data, and Children:

```
function theStruct = parseXML(filename)
% PARSEXML Convert XML file to a MATLAB structure.
try
 tree = xmlread(filename);
catch
 error('Failed to read XML file %s.',filename);
end

% Recurse over child nodes. This could run into problems
% with very deeply nested trees.
try
 theStruct = parseChildNodes(tree);
catch
 error('Unable to parse XML file %s.',filename);
end

% ----- Local function PARSECHILDNODES -----
function children = parseChildNodes(theNode)
% Recurse over node children.
children = [];
if theNode.hasChildNodes
 childNodes = theNode.getChildNodes;
 numChildNodes = childNodes.getLength;
 allocCell = cell(1, numChildNodes);

 children = struct(
 'Name', allocCell, 'Attributes', allocCell, ...
```



```
 'Data', allocCell, 'Children', allocCell);

 for count = 1:numChildNodes
 theChild = childNodes.item(count-1);
 children(count) = makeStructFromNode(theChild);
 end
end

% ----- Local function MAKESTRUCTFROMNODE -----
function nodeStruct = makeStructFromNode(theNode)
% Create structure of node info.

nodeStruct = struct(
 'Name', char(theNode.getNodeName), ...
 'Attributes', parseAttributes(theNode), ...
 'Data', '', ...
 'Children', parseChildNodes(theNode));

if any(strcmp(methods(theNode), 'getData'))
 nodeStruct.Data = char(theNode.getData);
else
 nodeStruct.Data = '';
end

% ----- Local function PARSEATTRIBUTES -----
function attributes = parseAttributes(theNode)
% Create attributes structure.

attributes = [];
if theNode.hasAttributes
 theAttributes = theNode.getAttributes;
 numAttributes = theAttributes.getLength;
 allocCell = cell(1, numAttributes);
 attributes = struct('Name', allocCell, 'Value', ...
 allocCell);

 for count = 1:numAttributes
```

# xmlread

---

```
 attrib = theAttributes.item(count-1);
 attributes(count).Name = char(attrib.getName);
 attributes(count).Value = char(attrib.getValue);
 end
end
```

## See Also

[xmlwrite](#) | [xslt](#)

## How To

- “What Is an XML Document Object Model (DOM)?”
- “Example — Finding Text in an XML File”

## Related Links

- [DOM Package Summary \(methods and properties for nodes\)](#)

<b>Purpose</b>	Write XML Document Object Model node
<b>Syntax</b>	<pre>xmlwrite(filename,DOMnode) str = xmlwrite(DOMnode)</pre>
<b>Description</b>	<p>xmlwrite(filename,DOMnode) writes the Document Object Model (DOM) node DOMnode to the file filename.</p> <p>str = xmlwrite(DOMnode) serializes the DOM node to a string.</p>
<b>Input Arguments</b>	<p><b>filename</b></p> <p>String enclosed in single quotation marks that specifies the name of a local file or a URL.</p> <p><b>DOMnode</b></p> <p>Document Object Model node, as defined by the World Wide Web consortium. For more information, see “What Is an XML Document Object Model (DOM)?”</p>
<b>Output Arguments</b>	<p><b>str</b></p> <p>String that contains the serialized DOM node as it appears in an XML file.</p>
<b>Examples</b>	<p>Create and view an XML document:</p> <pre>docNode = com.mathworks.xml.XMLUtils.createDocument...     ('root_element') docRootNode = docNode.getDocumentElement; docRootNode.setAttribute('attr_name','attr_value'); for i=1:20     thisElement = docNode.createElement('child_node');     thisElement.appendChild...         (docNode.createTextNode(sprintf('%i',i)));     docRootNode.appendChild(thisElement); end</pre>

# xmlwrite

---

```
docNode.appendChild(docNode.createComment('this is a comment'));

xmlFileName = [tempname, '.xml'];
xmlwrite(xmlFileName, docNode);
type(xmlFileName);
```

## See Also

[xmlread](#) | [xslt](#)

## How To

- “What Is an XML Document Object Model (DOM)?”
- “Creating an XML File”

## Related Links

- [DOM Package Summary \(methods and properties for nodes\)](#)

**Purpose** Logical exclusive-OR

**Syntax** `C = xor(A, B)`

**Description** `C = xor(A, B)` performs an exclusive OR operation on the corresponding elements of arrays A and B. The resulting element `C(i, j, ...)` is logical true (1) if `A(i, j, ...)` or `B(i, j, ...)`, but not both, is nonzero.

A	B	C
Zero	Zero	0
Zero	Nonzero	1
Nonzero	Zero	1
Nonzero	Nonzero	0

**Examples** Given `A = [0 0 pi eps]` and `B = [0 -2.4 0 1]`, then

```
C = xor(A,B)
C =
 0 1 1 0
```

To see where either A or B has a nonzero element and the other matrix does not,

```
spy(xor(A,B))
```

**See Also** `all` | `any` | `find` | `and` | `or` | `not` | Logical Operators: Short Circuit

**Concepts**

- “Truth Table for Logical Operations”

# xslt

---

**Purpose** Transform XML document using XSLT engine

**Syntax**

```
result = xslt(source, style, dest)
[result,style] = xslt(___)
xslt(___ , '-web')
```

**Description** `result = xslt(source, style, dest)` transforms an XML document using a stylesheet and returns the resulting document's URL. The function uses these inputs, the first of which is required:

- `source` is the filename or URL of the source XML file. `source` can also specify a DOM node.
- `style` is the filename or URL of an XSL stylesheet.
- `dest` is the filename or URL of the desired output document. If `dest` is absent or empty, the function uses a temporary filename. If `dest` is `'-tostring'`, the function returns the output document as a MATLAB string.

`[result,style] = xslt( ___ )` returns a processed stylesheet appropriate for passing to subsequent XSLT calls as `style`. This prevents costly repeated processing of the stylesheet.

`xslt( ___ , '-web')` displays the resulting document in the Help Browser.

**Tips** MATLAB uses the Saxon XSLT processor, version 6.5.5, which supports XSLT 1.0 expressions. For more information, see <http://saxon.sourceforge.net/saxon6.5.5/>

For additional information on writing XSL stylesheets, see the World Wide Web Consortium (W3C®) web site, <http://www.w3.org/Style/XSL/>.

**Examples** This example converts the file `info.xml` using the stylesheet `info.xsl`, writing the output to the file `info.html`. It launches the resulting HTML file in the MATLAB Web Browser.

```
xslt('info.xml', 'info.xsl', 'info.html', '-web')
```

**See Also**

```
xmlread | xmlwrite
```

# zeros

---

## Purpose

Create array of all zeros

## Syntax

```
X = zeros
X = zeros(n)
X = zeros(sz1, ..., szN)
X = zeros(sz)

X = zeros(classname)
X = zeros(n, classname)
X = zeros(sz1, ..., szN, classname)
X = zeros(sz, classname)

X = zeros('like', p)
X = zeros(n, 'like', p)
X = zeros(sz1, ..., szN, 'like', p)
X = zeros(sz, 'like', p)
```

## Description

`X = zeros` returns the scalar 0.

`X = zeros(n)` returns an n-by-n matrix of zeros.

`X = zeros(sz1, ..., szN)` returns an sz1-by-...-by-szN array of zeros where sz1, ..., szN indicates the size of each dimension. For example, `zeros(2,3)` returns a 2-by-3 array of zeros.

`X = zeros(sz)` returns an array of zeros where the size vector, sz, defines `size(X)`. For example, `zeros([2,3])` returns a 2-by-3 array of zeros.

`X = zeros(classname)` returns a scalar 0 where the string, classname, specifies the data type. For example, `zeros('int8')` returns a scalar, 8-bit integer 0.



`X = zeros(n,classname)` returns an n-by-n array of zeros of data type `classname`.

`X = zeros(sz1,...,szN,classname)` returns an sz1-by-...-by-szN array of zeros of data type `classname`.

`X = zeros(sz,classname)` returns an array of zeros where the size vector, `sz`, defines `size(X)` and `classname` defines `class(X)`.

`X = zeros('like',p)` returns a scalar 0 with the same data type, sparsity, and complexity (real or complex) as the numeric variable, `p`.

`X = zeros(n, 'like', p)` returns an n-by-n array of zeros like `p`.

`X = zeros(sz1,...,szN, 'like', p)` returns an sz1-by-...-by-szN array of zeros like `p`.

`X = zeros(sz, 'like', p)` returns an array of zeros like `p` where the size vector, `sz`, defines `size(X)`.

## **Input Arguments**

### **n - Size of square matrix**

integer value

Size of square matrix, specified as an integer value, defines the output as a square, n-by-n matrix of zeros.

- If `n` is 0, then `X` is an empty matrix.
- If `n` is negative, then it is treated as 0.

### **Data Types**

double | single | int8 | int16 | int32 | int64 | uint8 |  
uint16 | uint32 | uint64

### **sz1,...,szN - Size of each dimension**

two or more integer values

Size of each dimension, specified as two or more integer values, defines X as a sz1-by...-by-szN array.

- If the size of any dimension is 0, then X is an empty array.
- If the size of any dimension is negative, then it is treated as 0.
- If any trailing dimensions greater than 2 have a size of 1, then the output, X, does not include those dimensions.

### Data Types

double | single | int8 | int16 | int32 | int64 | uint8 |  
uint16 | uint32 | uint64

### sz - Output size

row vector of integer values

Output size, specified as a row vector of integer values. Each element of this vector indicates the size of the corresponding dimension.

- If the size of any dimension is 0, then X is an empty array.
- If the size of any dimension is negative, then it is treated as 0.
- If any trailing dimensions greater than 2 have a size of 1, then the output, X, does not include those dimensions.

**Example:** sz = [2,3,4] defines X as a 2-by-3-by-4 array.

### Data Types

double | single | int8 | int16 | int32 | int64 | uint8 |  
uint16 | uint32 | uint64

### classname - Output class

'double' (default) | 'single' | 'int8' | 'uint8' | ...

Output class, specified as 'double', 'single', 'int8', 'uint8', 'int16', 'uint16', 'int32', 'uint32', 'int64', or 'uint64'.

### Data Types

char

**p - Prototype**

numeric variable

Prototype, specified as a numeric variable.

**Data Types**double | single | int8 | int16 | int32 | int64 | uint8 |  
uint16 | uint32 | uint64**Complex Number Support:** Yes**Examples****Square Array of Zeros**

Create a 4-by-4 array of zeros.

```
X = zeros(4)
```

```
X =
```

```
 0 0 0 0
 0 0 0 0
 0 0 0 0
 0 0 0 0
```

**3-D Array of Zeros**

Create a 2-by-3-by-4 array of zeros.

```
X = zeros(2,3,4);
```

```
size(X)
```

```
ans =
```

```
 2 3 4
```

**Size Defined by Existing Array**

Define a 3-by-2 array A.

```
A = [1 4 ; 2 5 ; 3 6];
```

```
sz = size(A)
```

```
sz =
```

```
 3 2
```

Create an array of zeros that is the same size as A

```
X = zeros(sz)
```

```
X =
```

```
 0 0
 0 0
 0 0
```

## Nondefault Numeric Data Type

Create a 1-by-3 vector of zeros whose elements are 32-bit unsigned integers.

```
X = zeros(1,3,'uint32'),
class(X)
```

```
X =
```

```
 0 0 0
```

```
ans =
```

```
uint32
```

## Complex Zero

Create a scalar 0 that is not real valued, but instead is complex like an existing array.

Define a complex vector.

```
p = [1+2i 3i];
```

Create a scalar 0 that is complex like p.

```
X = zeros('like',p)
```

```
X =
```

```
0.0000 + 0.0000i
```

### **Sparse Array**

Define a 10-by-10 sparse matrix.

```
p = sparse(10,10,pi);
```

Create a 2-by-3 matrix of zeros that is sparse like p.

```
X = zeros(2,3,'like',p)
```

```
X =
```

```
All zero sparse: 2-by-3
```

### **Size and Numeric Data Type Defined by Existing Array**

Define a 2-by-3 array of 8-bit unsigned integers.

```
p = uint8([1 3 5 ; 2 4 6]);
```

Create an array of zeros that is the same size and data type as p.

```
X = zeros(size(p),'like',p),
class(X)
```

```
X =
```

```
0 0 0
0 0 0
```

# zeros

---

```
ans =
```

```
uint8
```

## See Also

`eye` | `ones` | `rand` | `randn` | `complex` | `false` | `size`

## Concepts

- “Class Support for Array-Creation Functions”
- “Preallocating Arrays”

---

<b>Purpose</b>	Compress files into zip file
<b>Syntax</b>	<pre>zip(zipfile,files) zip(zipfile,files,rootfolder) entrynames = zip(zipfile,files,rootfolder)</pre>
<b>Description</b>	<p><code>zip(zipfile,files)</code> creates a zip file with the name <code>zipfile</code> from the list of files and folders specified in <code>files</code>. Folders recursively include all of their content.</p> <p><code>zip(zipfile,files,rootfolder)</code> specifies the path for <code>files</code> relative to <code>rootfolder</code> instead of the current folder.</p> <p><code>entrynames = zip(zipfile,files,rootfolder)</code> returns a string cell array of the names of the files contained in <code>zipfile</code>. Specifying <code>rootfolder</code> is optional.</p>
<b>Input Arguments</b>	<p><b>zipfile</b></p> <p>String that specifies the name of the zip file. If <code>zipfile</code> has no extension, MATLAB appends the <code>.zip</code> extension.</p> <p>If <code>files</code> includes relative paths, the zip file also contains relative paths. The zip file does not include absolute paths.</p> <p><b>files</b></p> <p>String or cell array of strings containing the list of files or folders to include in <code>zipfile</code>.</p> <p>Individual files that are on the MATLAB path can be specified as partial path names. Otherwise an individual file can be specified relative to the current folder or with an absolute path.</p> <p>Folders must be specified relative to the current folder or with absolute paths. On UNIX systems, folders can also start with <code>~/</code> or <code>~username/</code>, which expands to the current user's home folder or the specified user's home folder, respectively. The wildcard character <code>*</code> can be used when specifying files or folders, except when relying on the MATLAB path to resolve a file name or partial path name.</p>

## **rootfolder**

String that specifies the root of the paths for the files to zip.

Relative paths in the zip file reflect the relative paths in files, and do not include path information from `rootfolder`.

**Default:** current folder ('.')

## **Output Arguments**

### **entrynames**

Cell array of strings that contain the paths to the files in `zipfile`. If `files` includes relative paths, `entrynames` also contains relative paths.

## **Examples**

### **Zip a File**

Create a zip file of the file `membrane.m`, which is in the MATLAB general folder. Save the zip file `tmwlogo.zip` in the current folder.

```
file = fullfile(matlabroot,'toolbox','matlab','general','membrane.m');
zip('tmwlogo',file);
```

### **Zip Selected Files**

Suppose that your system has a folder named `d:/myfiles`. Zip the files `membrane.m` and `logo.m`, which are on the MATLAB search path, into a file named `tmwlogo.zip`.

```
myfile = fullfile('d:','myfiles','tmwlogo.zip');
zip(myfile,{'membrane.m','logo.m'});
```

Zip all `.m` and `.mat` files in the current folder to the file `backup.zip`.

```
zip('backup',{'*.m','*.mat'});
```



## Zip a Folder

Suppose that your current folder contains a subfolder named `mywork`. Zip the contents of all subfolders of `mywork`, and store the relative paths in the zip file.

```
zip('myfiles.zip','mywork');
```

## Zip Between Folders

Suppose that you have files `thesis.doc` and `defense.ppt` in `d:/PhD`. Zip these files into `thesis.zip`, one level up from the current folder.

```
zip('../thesis.zip',{'thesis.doc','defense.ppt'],'d:/PhD');
```

## Create Zip Archive of Web Page

Create a zip archive of a Web page.

Locate the list of files at the MATLAB Central File Exchange uploaded within the past 7 days, that contain "Simulink."

```
filex = 'http://www.mathworks.com/matlabcentral/fileexchange/';
params = {'duration','7','term','simulink'};
```

Save the Web content to a file.

```
urlwrite(filex,'contains_simulink.html','get',params);
```

Create a zip archive of the retrieved Web page, using the `zip` function.

```
zip('simulink_matches.zip','contains_simulink.html');
```

`zip` creates a zip archive named `simulink_matches.zip` that contains the file, `contains_simulink.html`.

## Alternatives

To zip files in the Current Folder browser, select the files, right-click to open the context menu, and then select **Create Zip File**.

# zip

---

## **See Also**

`gzip` | `gunzip` | `tar` | `untar` | `unzip`

**Purpose** Turn zooming on or off or magnify by factor

**Syntax**

```
zoom on
zoom off
zoom out
zoom reset
zoom
zoom xon
zoom yon
zoom(factor)
zoom(fig, option)
h = zoom(figure_handle)
```

**Description** `zoom on` turns on interactive zooming. When interactive zooming is enabled in a figure, pressing a mouse button while your cursor is within an axes zooms into the point or out from the point beneath the mouse. Zooming changes the axes limits. When using zoom mode, you

- Zoom in by positioning the mouse cursor where you want the center of the plot to be and either
  - Press the mouse button or
  - Rotate the mouse scroll wheel away from you (upward).
- Zoom out by positioning the mouse cursor where you want the center of the plot to be and either
  - Simultaneously press **Shift** and the mouse button, or
  - Rotate the mouse scroll wheel toward you (downward).

Each mouse click or scroll wheel click zooms in or out by a factor of 2.

Clicking and dragging over an axes when zooming in is enabled draws a rubberband box. When you release the mouse button, the axes zoom in to the region enclosed by the rubberband box.

Double-clicking over an axes returns the axes to its initial zoom setting in both zoom-in and zoom-out modes.

`zoom off` turns interactive zooming off.

`zoom out` returns the plot to its initial zoom setting.

`zoom reset` remembers the current zoom setting as the initial zoom setting. Later calls to `zoom out`, or double-clicks when interactive zoom mode is enabled, will return to this zoom level.

`zoom` toggles the interactive zoom status between off and on (restoring the most recently used zoom tool).

`zoom xon` and `zoom yon` set `zoom on` for the  $x$ - and  $y$ -axis, respectively.

`zoom(factor)` zooms in or out by the specified zoom factor, without affecting the interactive zoom mode. Values greater than 1 zoom in by that amount, while numbers greater than 0 and less than 1 zoom out by  $1/\text{factor}$ .

`zoom(fig, option)` Any of the preceding options can be specified on a figure other than the current figure using this syntax.

`h = zoom(figure_handle)` returns a *zoom mode object* for the figure `figure_handle` for you to customize the mode's behavior.

## Using Zoom Mode Objects

Access the following properties of zoom mode objects via `get` and modify some of them using `set`.

- *Enable* 'on' | 'off' — Specifies whether this figure mode is currently enabled on the figure
- *FigureHandle* <handle> — The associated figure handle, a read-only property that cannot be set
- *Motion* 'horizontal' | 'vertical' | 'both' — The type of zooming enabled for the figure
- *Direction* 'in' | 'out' — The direction of the zoom operation
- *RightClickAction* 'InverseZoom' | 'PostContextMenu' — The behavior of a right-click action

A value of 'InverseZoom' causes a right-click to zoom out. A value of 'PostContextMenu' displays a context menu. This setting persists between MATLAB sessions.

- `UIContextMenu <handle>` — Specifies a custom context menu to be displayed during a right-click action

This property is ignored if the `RightClickAction` property has been set to 'on'.

## Zoom Mode Callbacks

You can program the following callbacks for zoom mode operations.

- `ButtonDownFilter <function_handle>` — Function to intercept `ButtonDown` events

The application can inhibit the zoom operation under circumstances the programmer defines, depending on what the callback returns. The input function handle should reference a function with two implicit arguments (similar to Handle Graphics object callbacks), as follows:

```
function [res] = myfunction(obj,event_obj)
% obj handle to the object clicked on
% event_obj struct for event data (empty in this release)
% res [output] a logical flag determines whether the zoom
% operation should take place(for 'res' set
% to 'false' or the 'ButtonDownFcn' property
% of the object should take precedence (when
% 'res' is 'true')
```

- `ActionPreCallback <function_handle>` — Function to execute before zooming

Set this callback if you want to execute code when a zoom operation starts. The input function handle should reference a function with two implicit arguments (similar to Handle Graphics object callbacks), as follows:

```
function myfunction(obj,event_obj)
% obj handle to the figure clicked on
% event_obj object containing struct of event data
```

The event data has the following field.

Axes	The handle of the axes that is being zoomed
------	---------------------------------------------

- `ActionPostCallback <function_handle>` — Function to execute after zooming

Set this callback if you want to execute code when a zoom operation finishes. The input function handle should reference a function with two implicit arguments (similar to Handle Graphics object callbacks), as follows:

```
function myfunction(obj,event_obj)
% obj handle to the figure clicked on
% event_obj object containing struct of event data
% (same as the event data of the
% 'ActionPreCallback' callback)
```

## Zoom Mode Utility Functions

The following functions in zoom mode query and set certain of its properties.

- `flags = isAllowAxesZoom(h,axes)` — Function querying permission to zoom axes

Calling the function `isAllowAxesZoom` on the zoom object, `h`, with a vector of axes handles, `axes`, as input returns a logical array of the same dimension as the axes handle vector, which indicates whether a zoom operation is permitted on the axes objects.

- `setAllowAxesZoom(h,axes,flag)` — Function to set permission to zoom axes

Calling the function `setAllowAxesZoom` on the zoom object, `h`, with a vector of axes handles, `axes`, and a logical scalar, `flag`, either allows or disallows a zoom operation on the axes objects.

- `info = getAxesZoomMotion(h,axes)` — Function to get style of zoom operations

Calling the function `getAxesZoomMotion` on the zoom object, `H`, with a vector of axes handles, `axes`, as input returns a character cell array of the same dimension as the axes handle vector, which indicates the type of zoom operation for each axes. Possible values for the type of operation are 'horizontal', 'vertical', or 'both'.

- `setAxesZoomMotion(h,axes,style)` — Function to set style of zoom operations

Calling the function `setAxesZoomMotion` on the zoom object, `h`, with a vector of axes handles, `axes`, and a character array, `style`, sets the style of zooming on each axes.

## Examples

### Example 1 — Entering Zoom Mode

Plot a graph and turn on Zoom mode:

```
plot(1:10);
zoom on
% zoom in on the plot
```

### Example 2 — Constrained Zoom

Create zoom mode object and constrain to *x*-axis zooming:

```
plot(1:10);
h = zoom;
set(h,'Motion','horizontal','Enable','on');
% zoom in on the plot in the horizontal direction.
```

### Example 3 — Constrained Zoom in Subplots

Create four axes as subplots and set zoom style differently for each by setting a different property for each axes handle:

```
ax1 = subplot(2,2,1);
plot(1:10);
h = zoom;
ax2 = subplot(2,2,2);
plot(rand(3));
```

```
setAllowAxesZoom(h,ax2,false);
ax3 = subplot(2,2,3);
plot(peaks);
setAxesZoomMotion(h,ax3,'horizontal');
ax4 = subplot(2,2,4);
contour(peaks);
setAxesZoomMotion(h,ax4,'vertical');
% Zoom in on the plots.
```

### Example 4 – Coding a ButtonDown Callback

Create a `ButtonDown` callback for zoom mode objects to trigger. Copy the following code to a new file, execute it, and observe zooming behavior:

```
function demo
% Allow a line to have its own 'ButtonDownFcn' callback.
hLine = plot(rand(1,10));
set(hLine,'ButtonDownFcn','disp(''This executes'')');
set(hLine,'Tag','DoNotIgnore');
h = zoom;
set(h,'ButtonDownFilter',@mycallback);
set(h,'Enable','on');
% mouse click on the line
%
function [flag] = mycallback(obj,event_obj)
% If the tag of the object is 'DoNotIgnore', then return true.
objTag = get(obj,'Tag');
if strcmpi(objTag,'DoNotIgnore')
 flag = true;
else
 flag = false;
end
```



### Example 5 – Coding Pre- and Post-Callback Behavior

Create callbacks for pre- and post-buttonDown events for zoom mode objects to trigger. Copy the following code to a new file, execute it, and observe zoom behavior:

```
function demo
% Listen to zoom events
plot(1:10);
h = zoom;
set(h,'ActionPreCallback',@myprecallback);
set(h,'ActionPostCallback',@mypostcallback);
set(h,'Enable','on');
%
function myprecallback(obj,evd)
disp('A zoom is about to occur.');
```

```
%
function mypostcallback(obj,evd)
newLim = get(evd.Axes,'XLim');
msgbox(sprintf('The new X-Limits are [%.2f %.2f].',newLim));
```

### Example 6 – Creating a Context Menu for Zoom Mode

Coding a context menu that lets the user to switch to Pan mode by right-clicking:

```
figure;plot(magic(10))
hCMZ = uicontextmenu;
hZMenu = uimenu('Parent',hCMZ,'Label','Switch to pan',...
'Callback','pan(gcf,'on')');
hZoom = zoom(gcf);
set(hZoom,'UIContextMenu',hCMZ);
zoom('on')
```

You cannot add items to the built-in zoom context menu, but you can replace it with your own.

# zoom

---

## Tips

zoom changes the axes limits by a factor of 2 (in or out) each time you press the mouse button while the cursor is within an axes. You can also click and drag the mouse to define a zoom area, or double-click to return to the initial zoom level.

You can create a zoom mode object once and use it to customize the behavior of different axes, as Example 3 illustrates. You can also change its callback functions on the fly.

---

**Note Do not change figure callbacks within an interactive mode.** While a mode is active (when panning, zooming, etc.), you will receive a warning if you attempt to change any of the figure's callbacks and the operation will not succeed. The one exception to this rule is the figure `WindowButtonMotionFcn` callback, which can be changed from within a mode. Therefore, if you are creating a GUI that updates a figure's callbacks, the GUI should somehow keep track of which interactive mode is active, if any, before attempting to do this.

---

When you assign different zoom behaviors to different subplot axes via a mode object and then link them using the `linkaxes` function, the behavior of the axes you manipulate with the mouse carries over to the linked axes, regardless of the behavior you previously set for the other axes.

## Alternatives

Use the Zoom tools  on the figure toolbar to zoom in or zoom out on a plot, or select **Zoom In** or **Zoom Out** from the figure's **Tools** menu. For details, see “Zooming in Graphs”.

## See Also

`linkaxes` | `pan` | `rotate3d`

**Purpose** Close Webcam preview window

**Syntax** `closePreview(cam)`

**Description** `closePreview(cam)` closes the Webcam preview window for the webcam object `cam`. You can close the preview at any time using the `closePreview` function. If you do not explicitly close the preview, it closes when you clear the webcam object.

## Examples **Close Webcam Preview**

This example shows how to close the Webcam preview window.

Find the name of your camera using the `webcamlist` function to ensure that MATLAB is discovering your camera(s).

```
webcamlist
```

```
ans =
```

```
 'Logitech Webcam 250'
 'Dell Camera C250'
```

Create the object. If you use the `webcam` function with the name of the camera (as a string) as the input argument, it creates the object and connects it to the camera with that name. You can use the exact name that is displayed by the `webcamlist` function. In the example above it would be 'Logitech Webcam 250'. You can also use a shortened version of the name, for example, the brand of the camera. In this case you could simply use 'Logitech' and it connects to the Logitech® Webcam. Use `cam` as the name of the object.

```
cam = webcam('Logitech')
```

```
cam =
```

```
webcam with properties:
```

# closePreview

---

```
 Name: 'Logitech Webcam 250'
 Resolution: '640x480'
 AvailableResolutions: {1x11 cell}
 Exposure: -4
 Gain: 253
 Saturation: 32
 WhiteBalance: 8240
 ExposureMode: 'auto'
 Sharpness: 48
 Brightness: 128
 BacklightCompensation: 1
 Contrast: 32
```

See that it creates the object and connects to the Logitech Webcam.

Preview the image from the Webcam.

```
preview(cam)
```

The preview window opens and displays live video stream from your camera. The preview dynamically updates, so if you change a property while previewing, the image changes to reflect the property change.

Close the preview.

```
closePreview(cam)
```

The preview window closes.

After you preview the image, the next steps are optionally changing any properties you need to set, and then acquiring images using the `snapshot` function. For more information on these steps, see the topics listed below.

## Related Examples

- “Connecting to Webcams”
- “Acquiring Images from Webcams”
- “Setting Properties for Webcam Acquisition”

**Purpose** Preview live video data from Webcam

**Syntax** `preview(cam)`

**Description** `preview(cam)` creates a preview window that displays live video data for webcam object `cam`. The size of the preview image is determined by the value of the `Resolution` property. The preview window shows a live RGB image from the Webcam and displays the camera name, resolution, frame rate, and the timestamp. Timestamp is the elapsed time since the object was created. To preview your image, call the `preview` function on the object name, which is `cam` in this example.

## Examples **Preview Webcam Image**

This example shows how to preview Webcam images.

Find the name of your camera using the `webcamlist` function to ensure that MATLAB is discovering your camera(s).

```
webcamlist
```

```
ans =
```

```
 'Logitech Webcam 250'
 'Dell Camera C250'
```

Create the object. If you use the `webcam` function with the name of the camera (as a string) as the input argument, it will create the object and connect it to the camera with that name. You can use the exact name that is displayed by the `webcamlist` function. In the example above it is `'Logitech Webcam 250'`. You can also use a shortened version of the name, for example, the brand of the camera. In this case you could simply use `'Logitech'` and it connects to the Logitech Webcam. Use `cam` as the name of the object.

```
cam = webcam('Logitech')

cam =
webcam with properties:
 Name: 'Logitech Webcam 250'
 Resolution: '640x480'
 AvailableResolutions: {1x11 cell}
 Exposure: -4
 Gain: 253
 Saturation: 32
 WhiteBalance: 8240
 ExposureMode: 'auto'
 Sharpness: 48
 Brightness: 128
 BacklightCompensation: 1
 Contrast: 32
```

See that it created the object and connected to the Logitech Webcam.

Preview the image from the Webcam.

```
preview(cam)
```

The preview window opens and displays live video stream from your camera. The preview dynamically updates, so if you change a property while previewing, the image changes to reflect the property change. The banner of the preview window shows the camera name. The lower portion of the window shows the timestamp in seconds, resolution, and the frame rate in frames per second. Timestamp is the elapsed time since the object was created.

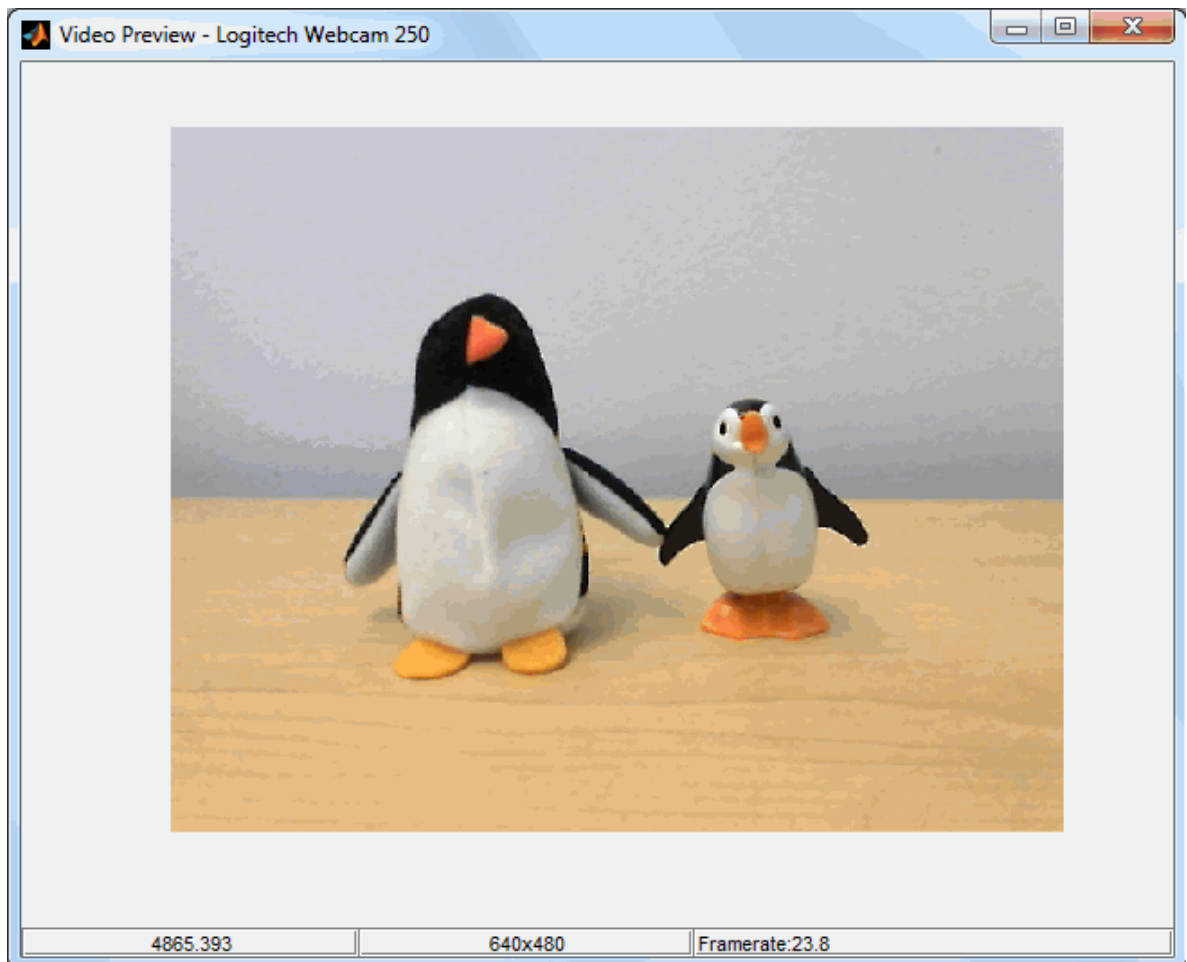

After you preview the image, the next steps are optionally changing any properties you need to set, and then acquiring images using the snapshot function. For more information on these steps, see the topics listed below.

## **Related Examples**

- “Connecting to Webcams”
- “Acquiring Images from Webcams”
- “Setting Properties for Webcam Acquisition”



**Purpose** Acquire single image frame from a Webcam

**Syntax** `img = snapshot(cam);`

**Description** `img = snapshot(cam);` acquires a single image from the Webcam `cam` and assigns it to the variable `img`. The `snapshot` function returns the current frame. Calling `snapshot` in a loop returns a new frame each time. The returned image is always an RGB image. `snapshot` uses the camera's default resolution or another resolution that you specify using the `Resolution` property.

## Examples **Acquire One Image Frame from Webcam**

This example shows how to acquire and display one image frame from a Webcam.

Find the name of your camera using the `webcamlist` function to ensure that MATLAB is discovering your camera(s).

```
webcamlist
```

```
ans =
```

```
 'Logitech Webcam 250'
 'Dell Camera C250'
```

Create the object. If you use the `webcam` function with the name of the camera (as a string) as the input argument, it creates the object and connects it to the camera with that name. You can use the exact name that is displayed by the `webcamlist` function. In the example above it would be `'Logitech Webcam 250'`. You can also use a shortened version of the name, for example, the brand of the camera. In this case you could simply use `'Logitech'` and it would connect to the Logitech Webcam. Use `cam` as the name of the object.

# snapshot

---

```
cam = webcam('Logitech')

cam =

webcam with properties:

 Name: 'Logitech Webcam 250'
 Resolution: '640x480'
 AvailableResolutions: {1x11 cell}
 Exposure: -4
 Gain: 253
 Saturation: 32
 WhiteBalance: 8240
 ExposureMode: 'auto'
 Sharpness: 48
 Brightness: 128
 BacklightCompensation: 1
 Contrast: 32
```

See that it creates the object and connects to the Logitech Webcam.

Preview the image from the Webcam.

```
preview(cam)
```

The preview window opens and displays live video stream from your camera. The preview dynamically updates, so if you change a property while previewing, the image changes to reflect the property change.

Close the preview.

```
closePreview(cam)
```

The preview window closes.

Acquire a single image from the camera using the `snapshot` function and assign it to the variable `img`.

```
img = snapshot(cam);
```

Display the acquired image.

```
imshow(img)
```

The `imshow` function is part of the Image Processing Toolbox. If you do not have that, you can use the `image` function that is part of MATLAB.

```
image(img)
```

Clean up by clearing the object.

```
clear('cam');
```

## **Related Examples**

- “Connecting to Webcams”
- “Acquiring Images from Webcams”
- “Setting Properties for Webcam Acquisition”

# webcam

---

**Purpose** Create webcam object to acquire images from Webcams

**Syntax**

```
cam = webcam
cam = webcam(devicenumber)
cam = webcam('cameraname')
```

**Description** `cam = webcam` creates the webcam object `cam` and connects to the single Webcam on your system. If you have multiple cameras and you use the `webcam` function with no input argument, it creates the object and connects it to the first camera it finds. This is the first camera listed in the output of the `webcamlist` function.

When the `webcam` object is created, it connects to the camera, establishes exclusive access, and starts streaming data. You can then preview the data and acquire images using the `snapshot` function.

`cam = webcam(devicenumber)` creates a webcam object `cam` where `devicenumber` is a numeric scalar value that identifies a particular Webcam by its index number. When you use the `webcam` function with an index as the input argument, it creates the object corresponding to that index and connects it to that camera. The index corresponds to the order of cameras in the cell array returned by `webcamlist` when you have multiple cameras connected.

Note that you cannot create more than one object connected to the same device, and trying to do that generates an error.

`cam = webcam('cameraname')` creates a webcam object `cam` where `cameraname` is a string value that identifies a particular Webcam by its name. When you use the `webcam` function with the name of the camera as the input argument, it creates the object and connects it to the camera with that name. You can use the exact name that is displayed by the `webcamlist` function, such as 'Logitech Webcam 250'. You can also use a shortened version of the name, for example, the brand of the camera. In this example you could simply use 'Logitech' and it would connect to the Logitech Webcam.

When the `webcam` object is created, it connects to the camera, establishes exclusive access, and starts streaming data from the camera. You can then preview the data and acquire images using the `snapshot` function.

Note that you cannot create more than one object connected to the same device, and trying to do that generates an error.

## Input Arguments

### **devicenumber - Device number of your camera**

numeric scalar

Device number of your hardware, specified as a numeric scalar. This number identifies a particular Webcam by its index number. It creates the object corresponding to that index and connects it to that camera. The index corresponds to the order of cameras in the cell array returned by `webcamList` when you have multiple cameras connected.

**Example:** `cam = webcam(2)`

### **Data Types**

double

### **cameraname - Name of your camera**

character string

Name of your camera, specified as a character string. This argument creates a `webcam` object `cam` where `cameraname` is a string value that identifies a particular Webcam by its name. When you use the `webcam` function with the name of the camera as the input argument, it creates the object and connects it to the camera with that name. You can use the exact name that is returned by the `webcamList` function, such as 'Logitech Webcam 250'. You can also use a shortened version of the name, for example, the brand of the camera. In this example you could simply use 'Logitech' and it would connect to the Logitech Webcam.

**Example:** `cam = webcam('Logitech')`

### **Data Types**

char

## Examples

### Create a Webcam Object Using No Arguments

This example shows how to create a `webcam` object with no arguments.

Find the name of your camera using the `webcamlist` function to ensure that MATLAB is discovering your camera(s).

```
webcamlist
```

```
ans =
```

```
 'Logitech Webcam 250'
 'Dell Camera C250'
```

If you use the `webcam` function with no input argument, it creates the object and connects it to the first camera it finds. This will be the first camera shown on the list if you have multiple cameras. If you only have one camera connected to your system, it uses that one. So in the example shown above, it creates the object using the Logitech camera, since that appears in the `webcamlist` output first. In this example, use `cam` as the name of the object.

```
cam = webcam
```

```
cam =
```

```
webcam with properties:
```

```
 Name: 'Logitech Webcam 250'
 Resolution: '640x480'
 AvailableResolutions: {1x11 cell}
 Exposure: -4
 Gain: 253
 Saturation: 32
 WhiteBalance: 8240
 ExposureMode: 'auto'
 Sharpness: 48
 Brightness: 128
 BacklightCompensation: 1
 Contrast: 32
```

See that it created the object and connected to the Logitech Webcam.

## Create a Webcam Object Using Device Number as an Index

This example shows how to create a webcam object using the device number as an index.

Find the name of your camera using the `webcamlist` function to ensure that MATLAB is discovering your camera(s).

```
webcamlist
```

```
ans =
```

```
 'Logitech Webcam 250'
 'Dell Camera C250'
```

If you use the `webcam` function with an index as the input argument, it creates the object corresponding to that index and connects it to that camera. The index corresponds to the order of cameras in the cell array returned by `webcamlist` when you have multiple cameras connected. So in the example shown above, device 1 is the Logitech camera and device 2 is the built-in Dell® Webcam. Use `cam` as the name of the object.

```
cam = webcam(2)
```

```
cam =
```

```
webcam with properties:
```

```
 Name: 'Dell Camera C250'
 Resolution: '320x240'
AvailableResolutions: ('320x240' '160x120' '80x60')
 Brightness: 128
 Contrast: 32
 Gain: 0
```

See that it created the object and connected to the Dell Webcam. If you only have one camera, you do not need to use the index. You can use the `webcam` function with no input argument and it creates the object



with the single camera that is connected. The index is useful when you have multiple cameras.

### Create a Webcam Object Using Camera Name

This example shows how to create a webcam object using the camera name.

Find the name of your camera using the `webcamlist` function to ensure that MATLAB is discovering your camera(s).

```
webcamlist
```

```
ans =
```

```
 'Logitech Webcam 250'
 'Dell Camera C250'
```

If you use the `webcam` function with the name of the camera (as a string) as the input argument, it creates the object and connects it to the camera with that name. You can use the exact name that is displayed by the `webcamlist` function. In the example above it would be `'Logitech Webcam 250'`. You can also use a shortened version of the name, for example, the brand of the camera. In this case you could simply use `'Logitech'` and it would connect to the Logitech Webcam. Use `cam` as the name of the object.

```
cam = webcam('Logitech')
```

```
cam =
```

```
webcam with properties:
```

```
 Name: 'Logitech Webcam 250'
 Resolution: '640x480'
AvailableResolutions: {1x11 cell}
 Exposure: -4
 Gain: 253
 Saturation: 32
```

# webcam

---

```
WhiteBalance: 8240
ExposureMode: 'auto'
 Sharpness: 48
 Brightness: 128
BacklightCompensation: 1
 Contrast: 32
```

See that it created the object and connected to the Logitech Webcam.

## **Related Examples**

- “Connecting to Webcams”
- “Acquiring Images from Webcams”
- “Setting Properties for Webcam Acquisition”

**Purpose** List of Webcams connected to your system

**Syntax** `webcamlist`

**Description** `webcamlist` returns a list of available UVC-compliant Webcams connected to your system. The function returns a cell array of names of the cameras. This supports the plug and play scenario, where using the `webcamlist` function again in the same MATLAB session returns an updated list of cameras if you plug in different cameras during the session.

The name of the camera that is shown in this output, for example 'Logitech Webcam 250', is the name you can use to create the Webcam object in order to acquire images.

## **Examples** **Display Single Webcam**

This example shows the output with a single camera.

If you have a single Webcam connected to your system, the output of `webcamlist` shows the one camera.

```
webcamlist
```

```
ans =
```

```
 'Logitech Webcam 250'
```

## **Display Multiple Internal and External Webcams**

This example shows the output with multiple cameras, including both internal and external.

If you have multiple Webcams connected to your system, the output shows all the cameras in a cell array.

# webcamlist

---

```
webcamlist
```

```
ans =
```

```
'Dell Camera C250'
'Logitech Webcam 250'
```

In this case it sees the built-in Webcam in the Dell computer, and a connected USB Webcam.

## Display Multiple External Webcams

This example shows the output with multiple cameras, including only external.

In this case, there are two cameras connected by USB ports.

```
webcamlist
```

```
ans =
```

```
'Logitech Webcam 250'
'Logitech Webcam Pro 9000'
```

## Related Examples

- “Connecting to Webcams”
- “Acquiring Images from Webcams”
- “Setting Properties for Webcam Acquisition”

# Functions — Alphabetical List

---

# cameraboard

---

**Purpose** Create connection to Raspberry Pi Camera Board Module

**Syntax**  
`mycamera = cameraboard(mypi)`  
`mycamera = cameraboard(mypi,Name,Value)`

**Description** `mycamera = cameraboard(mypi)` connects to a Camera Board and returns a handle, `mycamera`. You can capture video and still images by using `mycamera` with the `record`, `stop`, and `snapshot` methods.

`mycamera = cameraboard(mypi,Name,Value)` uses name-value pair arguments to override the default values of writable Camera Board properties. You can use these properties to control image properties such as size, resolution, orientation, exposure, and special effects.

Name must appear inside single quotes (' '). You can specify several name-value pair arguments in any order as `Name1,Value1,...,NameN,ValueN`.

## Input Arguments

### **mypi - Connection to specific board**

handle

Connection to a specific board, specified as a handle.

Use `raspi` to create this connection.

**Example:** `mypi`

### **Name-Value Pair Arguments**

Specify optional comma-separated pairs of `Name,Value` arguments. `Name` is the argument name and `Value` is the corresponding value. Name must appear inside single quotes (' '). You can specify several name and value pair arguments in any order as `Name1,Value1,...,NameN,ValueN`.

**Example:**

### **'Resolution' - Image dimensions**

'640x480' (default) | '160x120' | '320x240' | '800x600' |  
'1024x768' | '1280x720' | '1920x1080'

Image dimensions, specified as a string.

You can only specify this value when you create the `mycamera` handle.

**Example:** '1024x768'

### **Data Types**

char

### **'Quality' - JPEG image quality**

10 (default) | integer from 0 to 100

JPEG image quality, specified as a scalar from 1 to 100 (low to high).

The value of this parameter is inversely related to the amount of compression the camera performs upon the JPEG images. A value of 1 applies maximum compression, while a value of 100 applies minimal compression.

You can only specify this value when you create the `mycamera` handle.

**Example:** 10

### **Data Types**

double

### **'Rotation' - Degrees of clockwise rotation**

0 (default) | 90 | 180 | 270

Degrees of clockwise rotation, specified as 0, 90, 180, or 270.

Use this value to alter the orientation of the images captured by the Camera Board.

You can specify this value when you create the `mycamera` handle, and later by writing a new value to the property that has the same name.

**Example:** 180

### **Data Types**

double

## **'HorizontalFlip' - Enable horizontal flip**

0 (default) | 1

Enable horizontal flip, specified as a logical value.

Use this value to reverse the left and right orientation of the images captured by the Camera Board.

You can specify this value when you create the `mycamera` handle, and later by writing a new value to the property that has the same name.

**Example:** 1

### **Data Types**

logical

## **'VerticalFlip' - Flip image vertically**

0 (default) | 1

Flip image vertically, specified as a logical value.

Use this value to reverse the top and bottom orientation of the images captured by the Camera Board.

You can specify this value when you create the `mycamera` handle, and later by writing a new value to the property that has the same name.

**Example:** 1

### **Data Types**

logical

## **'FrameRate' - Video frame rate**

30 (default) | integer from 2 to 30

Video frame rate, specified as a scalar from 2 to 30 frames per second (fps).

You can only specify this value when you create the `mycamera` handle.

**Example:**

### **Data Types**

double



## **'Brightness' - Image brightness**

50 (default) | integer from 0 to 100

Image brightness, specified as a scalar from 0 to 100 (low to high).

You can specify this value when you create the mycamera handle, and later by writing a new value to the property that has the same name.

**Example:** 60

### **Data Types**

double

## **'Contrast' - Image contrast**

0 (default) | integer from -100 to 100

Image contrast, specified as a scalar from -100 to 100 (low to high).

You can specify this value when you create the mycamera handle, and later by writing a new value to the property that has the same name.

**Example:** 60

### **Data Types**

double

## **'Saturation' - Image color saturation**

0 (default) | integer from -100 to 100

Image color saturation, specified as a scalar from -100 to 100 (low to high).

You can specify this value when you create the mycamera handle, and later by writing a new value to the property that has the same name.

**Example:** 60

### **Data Types**

double

## **'Sharpness' - Image sharpness**

0 (default) | integer from -100 to 100

Image sharpness, specified as a scalar from -100 to 100 (low to high).

You can specify this value when you create the `mycamera` handle, and later by writing a new value to the property that has the same name.

**Example:** 60

## Data Types

double

## 'ExposureMode' - Exposure mode

'auto' (default) | 'night' | 'nightpreview' | 'backlight' | 'spotlight' | 'sports' | 'snow' | 'beach' | 'verylong' | 'fixedfps' | 'antishake' | 'fireworks'

Exposure mode, specified as a string.

Select the exposure mode for a variety of conditions, indicated by the name of the mode, or let the camera select the best mode (auto).

You can specify this value when you create the `mycamera` handle, and later by writing a new value to the property that has the same name.

**Example:** 'backlight'

## Data Types

char

## 'ExposureCompensation' - Exposure compensation

0 (default) | integer from -10 to 10

Exposure compensation, specified as a scalar from -10 to 10 (low to high).

Fine tune the automatic exposure. For example, if a backlit subject is too dark when `ExposureMode` is 'backlight', increase the value of `ExposureCompensation`.

You can specify this value when you create the `mycamera` handle, and later by writing a new value to the property that has the same name.

**Example:** -1

## Data Types

double

### 'AWBMode' - Automatic white balance mode

'auto (default) | 'off' | 'sun' | 'cloud' | 'shade' | 'tungsten' | 'fluorescent' | 'incandescent' | 'flash' | 'horizon'

Automatic white balance mode, specified as a string.

Select the white balance mode for a variety of conditions, indicated by the name of the mode, or let the camera select the best mode (auto).

You can specify this value when you create the `mycamera` handle, and later by writing a new value to the property that has the same name.

This mode adjusts the hue of the image to match the color temperature of various light sources.

For example, tungsten light bulbs tend to produce images that have an orange hue. To reduce this effect, set `AWBMode` to `auto` or `tungsten`. To keep this effect, set `AWBMode` to `off`. To heighten this effect, set `AWBMode` to `auto` or `shade`.

**Example:** `'backlight'`

## Data Types

char

### 'MeteringMode' - Metering mode

'average' (default) | 'spot' | 'backlit' | 'matrix'

Metering mode, specified as a string.

You can specify this value when you create the `mycamera` handle, and later by writing a new value to the property that has the same name.

This mode selects which portion of the image determines exposure.

- `average` — Uses values from across the scene, with a moderate bias toward values near the center.
- `spot` — Uses values from a very narrow area in the center of the image.

- `backlit` — Uses a cluster of lower values near the center of the image.
- `matrix` — Uses a values from grid of specific points in the image.

**Example:** `'backlight'`

## **Data Types**

`char`

### **'ImageEffect' - Special effect**

```
'none (default) | 'negative' | 'solarise' | 'sketch' | 'denoise'
| 'emboss' | 'oilpaint' | 'hatch' | 'gpen' | 'pastel' |
'watercolour' | 'film' | 'blur' | 'saturation' | 'colourswap' |
'washedout' | 'posterise' | 'colourpoint' | 'colourbalance' |
'cartoon'
```

Special effect, specified as a string.

Select the special effect indicated by the name of the mode, or disable special effects (auto).

You can specify this value when you create the `mycamera` handle, and later by writing a new value to the property that has the same name.

**Example:** `'cartoon'`

## **Data Types**

`char`

### **'VideoStabilization' - Video stabilization**

```
'off' (default) | 'on'
```

Video stabilization, specified as a string.

You can specify this value when you create the `mycamera` handle, and later by writing a new value to the property that has the same name.

Activate built-in video stabilization to reduce effects of vibration.

**Example:** `'on'`

## Data Types

char

### 'ROI' - Region of interest

[0.00 0.00 1.00 1.00] (default)

Region of interest (ROI), specified as a vector of four values: x, y, width, height.

You can specify this value when you create the `mycamera` handle, and later by writing a new value to the property that has the same name.

ROI defines which portion of the camera sensor to use. You can use this definition to perform digital panning and zooming while you record video.

For still images (`snapshot`) and video (`record`), the camera “smooths” ROI changes by applying them gradually over a sequence of image frames.

The following values define the starting point and size of the ROI:

- X, the vertical starting point, from 0.0000 to 1.0000 (top to bottom)
- Y, the horizontal starting point, from 0.0000 to 1.0000 (left to right)
- Height, from 0.0000 to 1.0000 (small to large)
- Width, from 0.0000 to 1.0000 (small to large)

The following illustration shows how X and Y position the ROI relative to the Camera Board sensor:

- The red dot is at X = 0.00 and Y = 0.00.
- The blue dot is at X = 1.00, Y = 1.00.

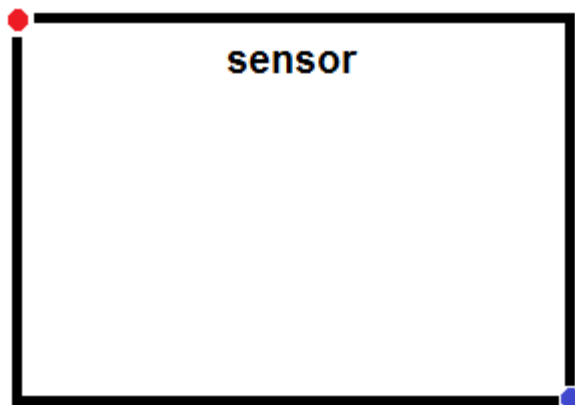

The following illustration represents the ROI from entering:

```
mycam.ROI = [0.50 0.50 0.33 0.33]
```

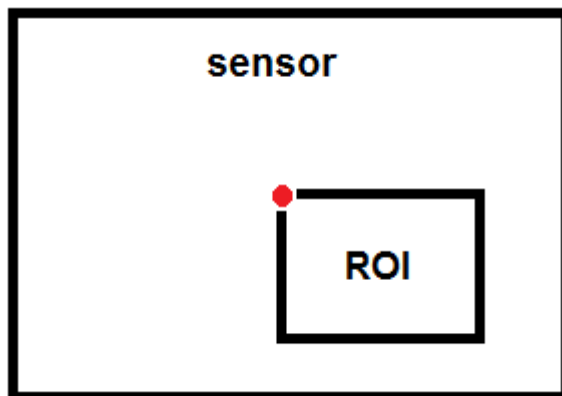

The 0.50 0.50 values place the top left corner of the ROI in the center of the sensor. The 0.33 0.33 values resize the ROI to one-third of the sensor. If ROI exceeds the dimensions of the sensor, the method that you are using produces the following error: `Index exceeds matrix dimensions.`

**Example:** [0.50 0.50 0.33 0.33]

### Data Types

double

## Output Arguments

### **mycamera - Connection to Raspberry Pi™ Camera Board**

handle

Connection to a Raspberry Pi Camera Board.

You can use `mycamera` with the following methods:

- `record`
- `stop`
- `snapshot`

You can use `mycamera` to read and write the properties specified by the “Name-Value Pair Arguments” on page 2-2.

You can use `mycamera` to read the value of the `Recording` property, which indicates whether the Camera Board is recording video.

## Examples

### **Use the Camera Board**

You can create a connection to the Camera Board, take a photograph, and record video.

Create a connection to the Raspberry Pi board.

```
mypi = raspi;
```

Create a connection to the Camera Board while changing the resolution, and assign that connection to a handle, `mycam`. The handle displays the Camera Board properties.

```
mycam = cameraboard(mypi, 'Resolution', '1280x720')
```

```
mycam =
```

```
Cameraboard with Properties:
```

# cameraboard

---

```
Name: Camera Board
Resolution: '1280x720' (View available resolutions)
Quality: 10 (1 to 100)
Rotation: 0 (0, 90, 180 or 270)
HorizontalFlip: 0
VerticalFlip: 0
FrameRate: 30 (2 to 30)
Recording: 0

Picture Settings
Brightness: 50 (0 to 100)
Contrast: 0 (-100 to 100)
Saturation: 0 (-100 to 100)
Sharpness: 0 (-100 to 100)

Exposure and AWB
ExposureMode: 'auto' (View available exposure modes)
ExposureCompensation: 0 (-10 to 10)
AWBMode: 'auto' (View available AWB modes)
MeteringMode: 'average' (View available metering modes)

Effects
ImageEffect: 'none' (View available image effects)
VideoStabilization: 'off'
ROI: [0.00 0.00 1.00 1.00] (0.0 to 1.0 [top, left, width, height])
```

Import and display a sequence of ten snapshots on your host computer.

```
for ii = 1:10
img = snapshot(mycam);
imagesc(img);
drawnow;
end
```

If the image is upside down, change the orientation of the image.

```
mycam.Rotation = 180;
```



You can use the same approach to change the values of many mycamera properties listed in the "Name-Value Pair Arguments" for cameraboard.

Record a 60 second video.

```
record(mycam, 'myvideo.mp4', 60)
```

Stop recording before the 60 seconds have elapsed.

```
stop(mycam)
```

Copy the video from the board to your host computer.

```
getFile(myapi, 'myvideo.mp4', 'C:\MATLAB')
```

Delete the video file from the board to free up space.

```
deleteFile(myapi, 'myvideo.mp4')
```

## See Also

[raspi](#) | [snapshot](#) | [record](#) | [stop](#) | [getFile](#) | [deleteFile](#) |  
"Raspberry Pi Hardware"

## Related Examples

- "Open Interactive Examples"

## External Web Sites

- [RaspiCam Documentation](#)

# configureDigitalPin

---

## Purpose

Configure GPIO pin as input or output

## Syntax

```
configureDigitalPin(myPi, pinNumber, direction)
```

## Description

`configureDigitalPin(myPi, pinNumber, direction)` configures a specific GPIO pin as a digital input or output.

## Input Arguments

### **myPi - Connection to specific board**

handle

Connection to a specific board, specified as a handle.

Use `raspi` to create this connection.

**Example:** `myPi`

### **pinNumber - GPIO pin number**

pin number

GPIO pin number, specified as a scalar. This argument does not accept vectors because the hardware cannot access multiple pins simultaneously.

To get a list of valid pin numbers, enter `myPi.AvailableDigitalPins`.

**Example:** `12`

### **Data Types**

double

### **direction - Pin direction**

input | output

Pin direction, specified as a string. Configures the pin as an input or an output. Accepts partial inputs.

**Example:** `'input'`

### **Data Types**

char

## Examples

### Configure Pin as Digital Input and Read Its Logical Value

You can configure a pin as digital input and read its logical value.

Create a connection to the Raspberry Pi board.

```
mypi = raspi
```

```
mypi =
```

```
Raspi with Properties:
```

```
 DeviceAddress: 'raspberrypi-computername'
 Port: 18725
 BoardName: 'Raspberry Pi Model B Rev 2'
 AvailableLEDs: {'led0'}
AvailableDigitalPins: [4 7 8 9 10 11 14 15 17 18 22 23 24 25 27 30 31]
AvailableSPIChannels: {}
 AvailableI2CBuses: {'i2c-0' 'i2c-1'}
 I2CBusSpeed: 100000
```

The `AvailableDigitalPins` property shows the list of digital pins that are available.

Redisplay `AvailableDigitalPins`.

```
mypi.AvailableDigitalPins
```

```
ans =
```

```
Columns 1 through 13
```

```
 4 7 8 9 10 11 14 15 17 18 22 23 24
```

```
Columns 14 through 17
```

```
 25 27 30 31
```

Show the location of the GPIO 4.

# configureDigitalPin

```
showPins(myPi)
```

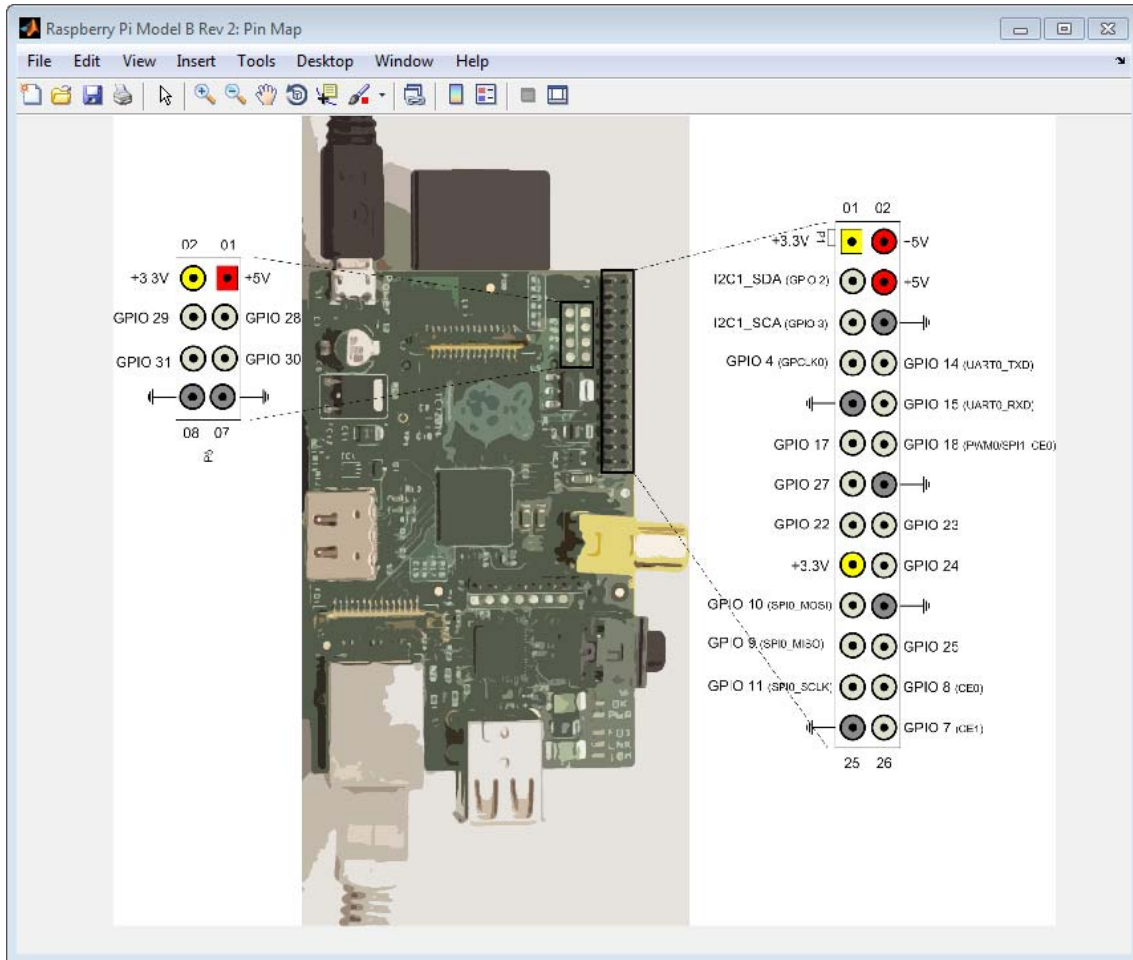

Connect the digital device you are using to GPIO 4.

Configure pin 4 as a digital input.

```
configureDigitalPin(myPi,4,'input')
```

Read the value from pin 4.

```
readDigitalPin(myPi,4)
```

```
ans =
```

```
1
```

## Configure Pin as Digital Output and Write Its Logical Value

You can configure a pin as digital output and write its logical value.

Create a connection to the Raspberry Pi board.

```
myPi = raspi
```

```
myPi =
```

```
Raspi with Properties:
```

```
 DeviceAddress: 'raspberrypi-computername'
 Port: 18725
 BoardName: 'Raspberry Pi Model B Rev 2'
 AvailableLEDs: {'led0'}
 AvailableDigitalPins: [4 7 8 9 10 11 14 15 17 18 22 23 24 25 27 30 31]
 AvailableSPIChannels: {}
 AvailableI2CBuses: {'i2c-0' 'i2c-1'}
 I2CBusSpeed: 100000
```

The `AvailableDigitalPins` property shows the list of digital pins that are available.

Redisplay `AvailableDigitalPins`.

```
myPi.AvailableDigitalPins
```

```
ans =
```

```
Columns 1 through 13
```

# configureDigitalPin

---

```
4 7 8 9 10 11 14 15 17 18 22 23 24
```

```
Columns 14 through 17
```

```
25 27 30 31
```

Show the location of the GPIO 4.

```
showPins(myPi)
```

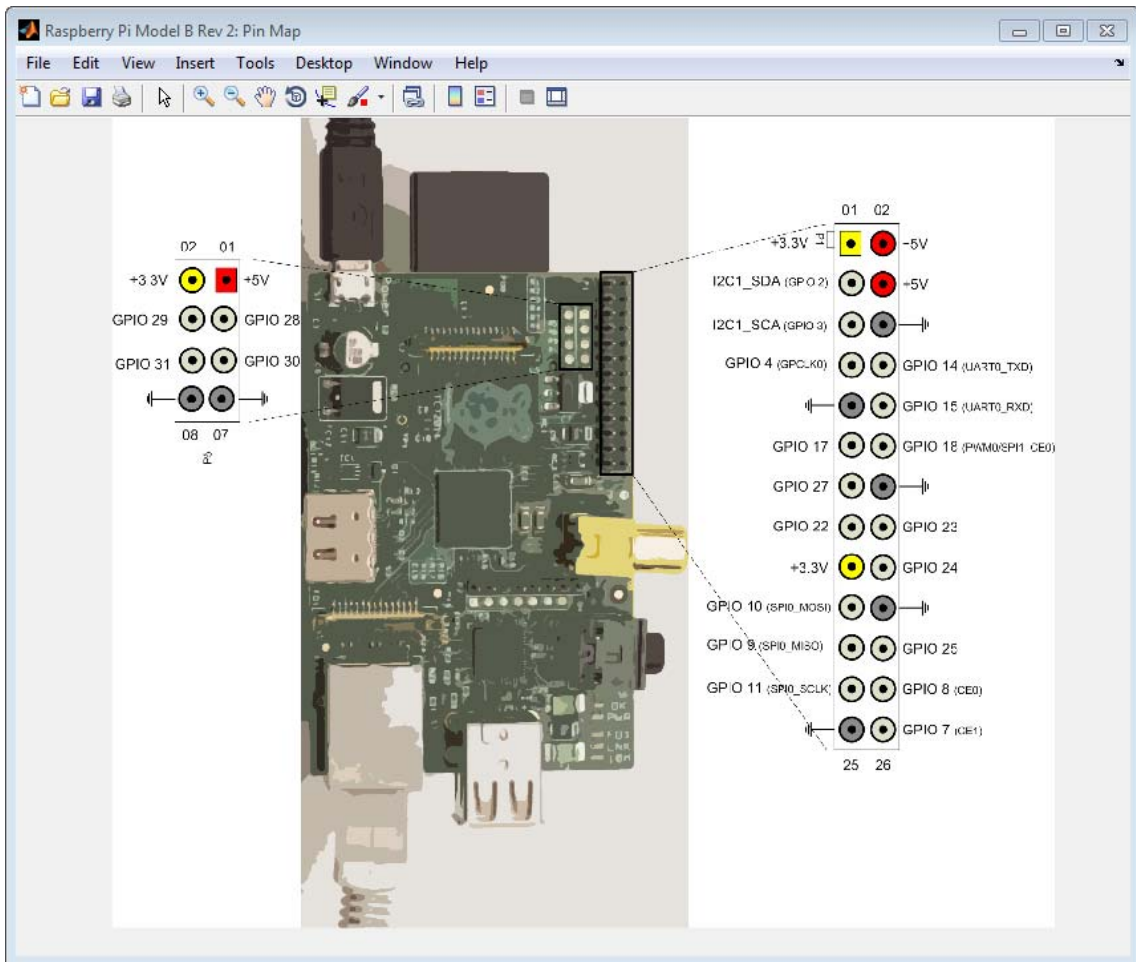

Connect the digital device you are using to GPIO 4.

Configure pin 4 as a digital output.

```
configureDigitalPin(mypi,4,'output')
```

Write a logical value of 1 to pin 4.

# configureDigitalPin

---

```
writeDigitalPin(mypi,4,1)
```

## See Also

[readDigitalPin](#) | [writeDigitalPin](#) | [showPins](#) | [raspi](#) | “Raspberry Pi Hardware”

## Related Examples

- [“Open Interactive Examples”](#)



**Purpose** Delete file on target hardware

**Syntax** `deleteFile(myPi, fileName)`

**Description** `deleteFile(myPi, fileName)`

**Input Arguments** **myPi - Connection to specific board**

handle

Connection to a specific board, specified as a handle.

Use `raspi` to create this connection.

**Example:** `myPi`

**fileName - File to delete**

file name

File to delete, specified as a string. You can delete a file on the Raspberry Pi hardware. When you specify the file name, you can use path information and wildcards.

**Example:**  `'/home/pi/cap.jpg'`

**Example:**  `'/home/pi/*.jpg'`

**Data Types**

cell

**Examples** **Delete File on Raspberry Pi Hardware**

You can delete a file on the Raspberry Pi hardware.

```
deleteFile(myPi, '/home/pi/cap.jpg');
```

**Delete Multiple Files on Raspberry Pi Hardware**

You can delete multiple files on the Raspberry Pi hardware using a wildcard character, `*`.

```
deleteFile(myPi, '/home/pi/*.jpg')
```

## Use the Camera Board

You can create a connection to the Camera Board, take a photograph, and record video.

Create a connection to the Raspberry Pi board.

```
mypi = raspi;
```

Create a connection to the Camera Board while changing the resolution, and assign that connection to a handle, mycam. The handle displays the Camera Board properties.

```
mycam = cameraboard(mypi, 'Resolution', '1280x720')
```

```
mycam =
```

```
Cameraboard with Properties:
```

```
 Name: Camera Board
 Resolution: '1280x720' (View available resolutions)
 Quality: 10 (1 to 100)
 Rotation: 0 (0, 90, 180 or 270)
HorizontalFlip: 0
VerticalFlip: 0
 FrameRate: 30 (2 to 30)
 Recording: 0

Picture Settings
 Brightness: 50 (0 to 100)
 Contrast: 0 (-100 to 100)
 Saturation: 0 (-100 to 100)
 Sharpness: 0 (-100 to 100)

Exposure and AWB
 ExposureMode: 'auto' (View available exposure modes)
 ExposureCompensation: 0 (-10 to 10)
 AWBMode: 'auto' (View available AWB modes)
```

```

 MeteringMode: 'average' (View available metering modes)

Effects
 ImageEffect: 'none' (View available image effects)
 VideoStabilization: 'off'
 ROI: [0.00 0.00 1.00 1.00] (0.0 to 1.0 [top, left, width, height])

```

Import and display a sequence of ten snapshots on your host computer.

```

for ii = 1:10
img = snapshot(mycam);
 imagesc(img);
 drawnow;
end

```

If the image is upside down, change the orientation of the image.

```
mycam.Rotation = 180;
```

You can use the same approach to change the values of many mycamera properties listed in the "Name-Value Pair Arguments" for cameraboard.

Record a 60 second video.

```
record(mycam, 'myvideo.mp4', 60)
```

Stop recording before the 60 seconds have elapsed.

```
stop(mycam)
```

Copy the video from the board to your host computer.

```
getFile(myip, 'myvideo.mp4', 'C:\MATLAB')
```

Delete the video file from the board to free up space.

```
deleteFile(myip, 'myvideo.mp4')
```

## See Also

system | openShell | getFile | putFile | cameraboard

# deleteFile

---

## **Related Examples**

- “Open Interactive Examples”

## **External Web Sites**

- [http://elinux.org/CLI\\_Spells](http://elinux.org/CLI_Spells)
- [http://linuxcommand.org/learning\\_the\\_shell.php](http://linuxcommand.org/learning_the_shell.php)

**Purpose** Disable I2C interface

**Syntax** `disableI2C(myPi)`

**Description** `disableI2C(myPi)` disables the I2C bus and makes the I2C pins available for use as GPIO pins instead. By default, the I2C bus is enabled.

For example, on a Raspberry Pi Model B Rev 2 board, disabling the I2C bus makes I2C1\_SDA (GPIO 2) and I2C1\_SCL (GPIO 3) available for use as GPIO pins.

To reenable I2C, use `enableI2C`.

## Input Arguments

### **myPi - Connection to specific board**

`handle`

Connection to a specific board, specified as a handle.

Use `raspi` to create this connection.

**Example:** `myPi`

## Examples

### **Connect and Exchange Data with I2C Devices**

You can connect and exchange data with a pair of I2C devices.

Create a connection to the Raspberry Pi board.

```
myPi = raspi
```

```
myPi =
```

```
Raspi with Properties:
```

```

 DeviceAddress: 'raspberrypi-computername'
 Port: 18725
 BoardName: 'Raspberry Pi Model B Rev 2'
 AvailableLEDs: {'led0'}
 AvailableDigitalPins: [4 7 8 9 10 11 14 15 17 18 22 23 24 25 27 30 31]
```

# disableI2C

---

```
AvailableSPIChannels: {}
AvailableI2CBuses: {'i2c-0' 'i2c-1'}
I2CBusSpeed: 100000
```

Supported peripherals

Redisplay AvailableI2CBuses and I2CBusSpeed.

```
mypi.AvailableI2CBuses
mypi.I2CBusSpeed
```

```
ans =
```

```
'i2c-0' 'i2c-1'
```

```
ans =
```

```
100000
```

Show the location of the I2C pins.

```
showPins(mypi)
```

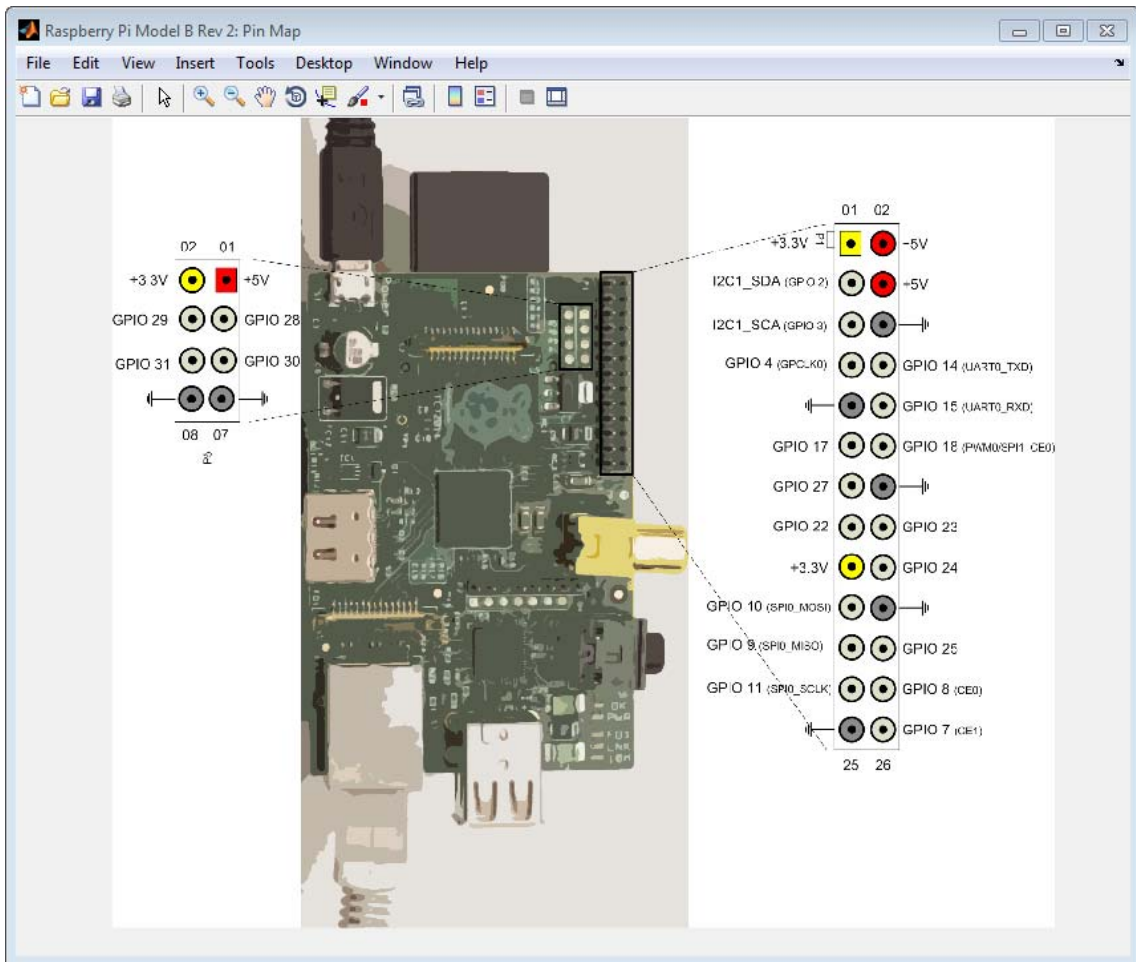

The pin map shows that, for this model and revision of the board, the i2c-1 bus is available on the GPIO header pins I2C1\_SDA (GPIO 2) and I2C1\_SCL (GPIO 3).

After physically connecting your I2C device to the I2C pins, get the addresses of I2C devices attached to the I2C bus, 'i2c-1'.

# disableI2C

---

```
scanI2CBus(mypi, 'i2c-1')
```

```
ans =
```

```
 {'0x55', '0x20'}
```

Create a connection to the I2C sensor at '0x20' and assign that connection to a handle, `i2csensor`.

```
i2csensor = i2cdev(mypi, 'i2c-1', '0x20')
```

```
i2csensor =
```

```
I2C with Properties:
```

```
 Bus: i2c-1
```

```
 I2CAddress: 0x20
```

```
 TimeOut: 10
```

Read two uint8 numbers from the sensor.

```
output1 = read(i2csensor, 2);
```

Read the value of register 14 from the sensor

```
output2 = readRegister(i2csensor, 14);
```

Create a connection to the I2C LED display at '0x55' and assign that connection to a handle, `i2cdisplay`.

```
i2cdisplay = i2cdev(mypi, 'i2c-1', '0x55')
```

```
i2cdisplay =
```

```
I2C with Properties:
```

```
 Bus: i2c-1
```

```
 I2CAddress: 0x55
```

```
 TimeOut: 10
```



Write characters to the display.

```
write(i2cdisplay,[hex2dec('20') hex2dec('51')]);
```

Write a scalar hexadecimal value, `hex2dec('08')`, to register 3 on an I2C device.

```
writeRegister(i2cdisplay,3,hex2dec('08'),'uint8');
```

If you are not using I2C, disable I2C to make additional GPIO pins available.

```
disableI2C(mypi)
```

When you use I2C again, enable I2C.

```
enableI2C(mypi)
```

You can only change the `mypi.I2CBusSpeed` property when you enable I2C.

```
disableI2C(mypi);
enableI2C(mypi,400000);
mypi.I2CBusSpeed
```

```
ans =
```

```
40000
```

## See Also

[raspi](#) | [scanI2Cbus](#) | [i2cdev](#) | [read](#) | [write](#) | [readRegister](#) | [writeRegister](#) | [enableI2C](#) | “Raspberry Pi Hardware”

## Related Examples

- “Open Interactive Examples”

# disableSPI

---

**Purpose** Disable SPI interface

**Syntax** `disableSPI(myPi)`

**Description** `disableSPI(myPi)` disables the SPI bus and makes the SPI pins available for use as GPIO pins instead. By default, SPI is disabled. This method works only after you have used `enableSPI`.

For example, on a Raspberry Pi Model B Rev 2 board, disabling the SPI bus makes GPIO 10 (SPI0\_MOSI), GPIO 9 (SPI0\_MISO), GPIO 11 (SPI0\_SCLK) available for use as GPIO pins.

**Input Arguments** **myPi - Connection to specific board**  
`handle`

Connection to a specific board, specified as a handle.

Use `raspi` to create this connection.

**Example:** `myPi`

**Examples** **Connect and Exchange Data with SPI Devices**

You can connect and exchange data with an SPI device.

Create a connection to the Raspberry Pi board.

```
myPi = raspi
```

```
myPi =
```

```
Raspi with Properties:
```

```
DeviceAddress: 'raspberrypi-computername'
Port: 18725
BoardName: 'Raspberry Pi Model B Rev 2'
AvailableLEDs: {'led0'}
AvailableDigitalPins: [4 7 8 9 10 11 14 15 17 18 22 23 24 25 27 30 31]
AvailableSPIChannels: {}
```

```
AvailableI2CBuses: {'i2c-0' 'i2c-1'}
I2CBusSpeed: 100000
```

Supported peripherals

By default, SPI is disabled and `AvailableSPIChannels` does not show any channels.

Enable SPI and get the channels.

```
enableSPI(myPi);
myPi.AvailableSPIChannels
```

```
ans =
```

```
'CE0' 'CE1'
```

Show the location of the SPI pins, GPIO 10 (SPI0\_MOSI), GPIO 9 (SPI0\_MISO), and GPIO 11 (SPI0\_SCLK), on the GPIO header.

```
showPins(myPi)
```

# disableSPI

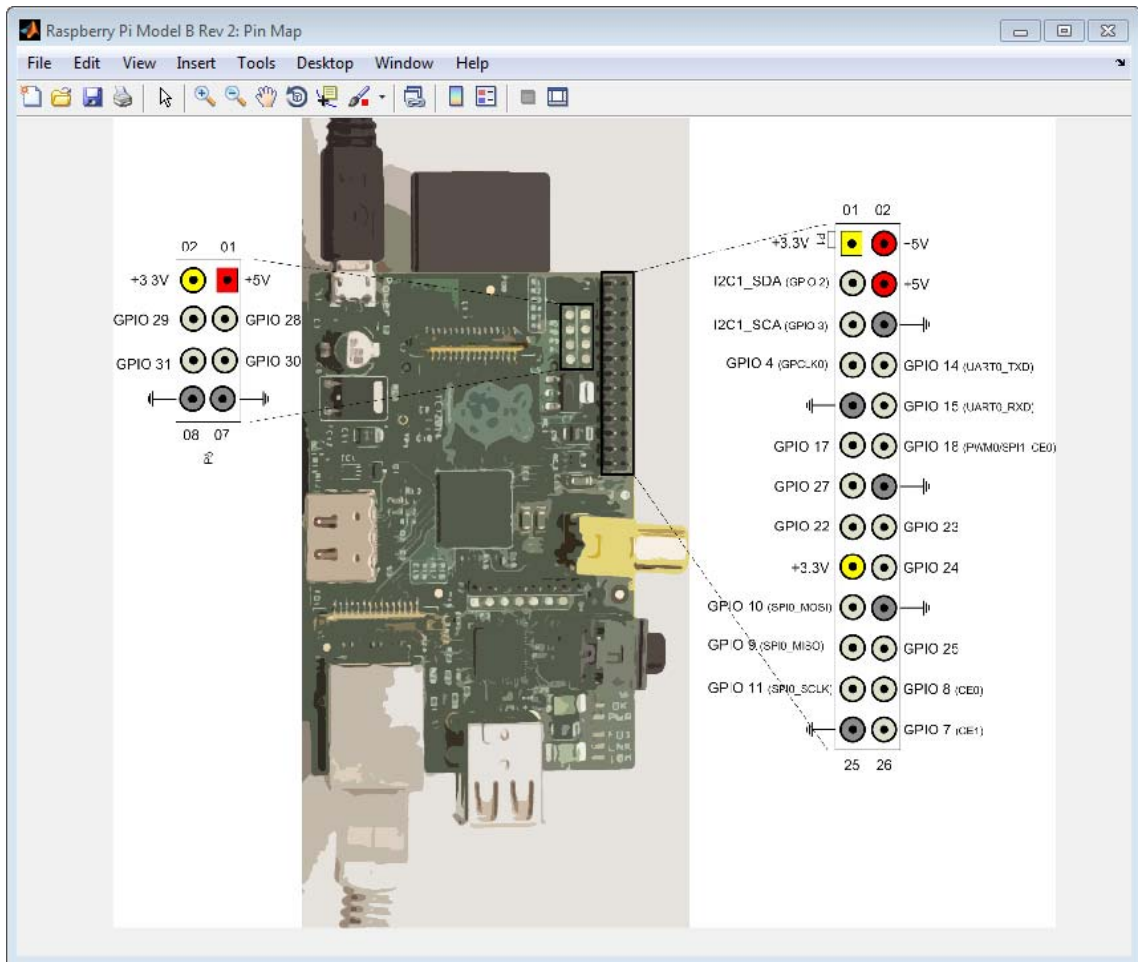

After physically connecting your SPI device to the three SPI pins, connect to the SPI device.

```
myspidevice = spidev(mypi, 'CE1', 0)
```

```
myspidevice =
```

```
Spidev with Properties:
 Channel: 'CE1'
 Mode: 0
 BitsPerWord: 8
 Speed: 500000
```

Write data to, and read data from, the SPI device.

```
out = writeRead(myspidevice,[hex2dec('08') hex2dec('D4')])
```

```
out =
 7 211
```

If you are not using SPI, disable SPI to make additional GPIO pins available.

```
disableSPI(mypi)
```

## See Also

[raspi](#) | [spidev](#) | [writeRead](#) | [enableSPI](#) | “Raspberry Pi Hardware”

## Related Examples

- “Open Interactive Examples”

# enableI2C

---

**Purpose** Enable I2C interface

**Syntax** `enableI2C(myPi)`  
`enableI2C(myPi, i2cBusSpeed)`

**Description** `enableI2C(myPi)` enables the I2C bus at the default bus speed, 100000, and makes the GPIO pins available for use as I2C pins instead. By default, the I2C bus is enabled. This method works only after you use `disableI2C`.

For example, on a Raspberry Pi Model B Rev 2 board, enabling the I2C bus makes I2C1\_SDA (GPIO 2) and I2C1\_SCL (GPIO 3) available for use as I2C pins.

`enableI2C(myPi, i2cBusSpeed)` enables the I2C bus and overrides the current bus speed.

## Input Arguments

### **myPi - Connection to specific board**

`handle`

Connection to a specific board, specified as a handle.

Use `raspi` to create this connection.

**Example:** `myPi`

### **i2cBusSpeed - I2C bus speed**

100000 (default) | 400000

I2C bus speed, specified as a scalar.

**Example:** 100000

### **Data Types**

`double`

## Examples

### **Connect and Exchange Data with I2C Devices**

You can connect and exchange data with a pair of I2C devices.

Create a connection to the Raspberry Pi board.

```
mypi = raspi
```

```
mypi =
```

```
Raspi with Properties:
```

```
 DeviceAddress: 'raspberrypi-computername'
 Port: 18725
 BoardName: 'Raspberry Pi Model B Rev 2'
 AvailableLEDs: {'led0'}
AvailableDigitalPins: [4 7 8 9 10 11 14 15 17 18 22 23 24 25 27 30 31]
AvailableSPICannels: {}
 AvailableI2CBuses: {'i2c-0' 'i2c-1'}
 I2CBusSpeed: 100000
```

```
Supported peripherals
```

Redisplay AvailableI2CBuses and I2CBusSpeed.

```
mypi.AvailableI2CBuses
```

```
mypi.I2CBusSpeed
```

```
ans =
```

```
 'i2c-0' 'i2c-1'
```

```
ans =
```

```
 100000
```

Show the location of the I2C pins.

```
showPins(mypi)
```

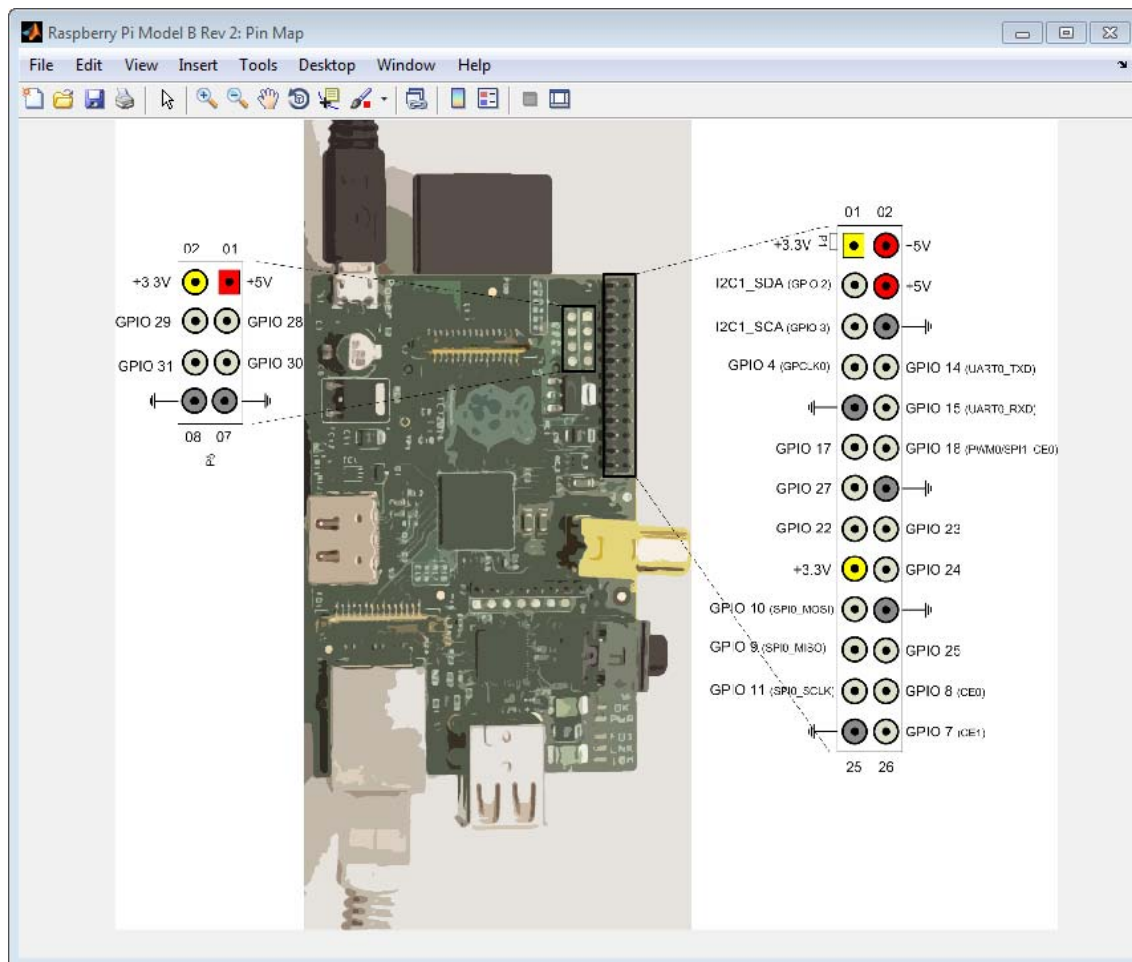

The pin map shows that, for this model and revision of the board, the i2c-1 bus is available on the GPIO header pins I2C1\_SDA (GPIO 2) and I2C1\_SCL (GPIO 3).

After physically connecting your I2C device to the I2C pins, get the addresses of I2C devices attached to the I2C bus, 'i2c-1'.



```
scanI2CBus(mypi, 'i2c-1')
```

```
ans =
```

```
 {'0x55', '0x20'}
```

Create a connection to the I2C sensor at '0x20' and assign that connection to a handle, `i2csensor`.

```
i2csensor = i2cdev(mypi, 'i2c-1', '0x20')
```

```
i2csensor =
```

```
I2C with Properties:
```

```
 Bus: i2c-1
```

```
 I2CAddress: 0x20
```

```
 TimeOut: 10
```

Read two uint8 numbers from the sensor.

```
output1 = read(i2csensor, 2);
```

Read the value of register 14 from the sensor

```
output2 = readRegister(i2csensor, 14);
```

Create a connection to the I2C LED display at '0x55' and assign that connection to a handle, `i2cdisplay`.

```
i2cdisplay = i2cdev(mypi, 'i2c-1', '0x55')
```

```
i2cdisplay =
```

```
I2C with Properties:
```

```
 Bus: i2c-1
```

```
 I2CAddress: 0x55
```

```
 TimeOut: 10
```

# enableI2C

---

Write characters to the display.

```
write(i2cdisplay,[hex2dec('20') hex2dec('51')]);
```

Write a scalar hexadecimal value, `hex2dec('08')`, to register 3 on an I2C device.

```
writeRegister(i2cdisplay,3,hex2dec('08'),'uint8');
```

If you are not using I2C, disable I2C to make additional GPIO pins available.

```
disableI2C(mypi)
```

When you use I2C again, enable I2C.

```
enableI2C(mypi)
```

You can only change the `mypi.I2CBusSpeed` property when you enable I2C.

```
disableI2C(mypi);
enableI2C(mypi,400000);
mypi.I2CBusSpeed
```

```
ans =
```

```
40000
```

## See Also

[raspi](#) | [scanI2Cbus](#) | [i2cdev](#) | [read](#) | [write](#) | [readRegister](#) | [writeRegister](#) | [disableI2C](#) | “Raspberry Pi Hardware”

## Related Examples

- “Open Interactive Examples”

**Purpose** Enable SPI interface

**Syntax** `enableSPI(myPi)`

**Description** `enableSPI(myPi)` enables the SPI bus and makes the GPIO pins available for use as SPI pins instead. By default, SPI is disabled.

For example, on a Raspberry Pi Model B Rev 2 board, enabling the SPI bus makes GPIO 10 (SPI0\_MOSI), GPIO 9 (SPI0\_MISO), GPIO 11 (SPI0\_SCLK) available for use as SPI pins.

To disable SPI, use `disableSPI`.

### Input Arguments

**myPi - Connection to specific board**  
handle

Connection to a specific board, specified as a handle.

Use `raspi` to create this connection.

**Example:** `myPi`

### Examples

#### Connect and Exchange Data with SPI Devices

You can connect and exchange data with an SPI device.

Create a connection to the Raspberry Pi board.

```
myPi = raspi
```

```
myPi =
```

```
Raspi with Properties:
```

```

 DeviceAddress: 'raspberrypi-computername'
 Port: 18725
 BoardName: 'Raspberry Pi Model B Rev 2'
 AvailableLEDs: {'led0'}
 AvailableDigitalPins: [4 7 8 9 10 11 14 15 17 18 22 23 24 25 27 30 31]
 AvailableSPIChannels: {}

```

# enableSPI

---

```
AvailableI2CBuses: {'i2c-0' 'i2c-1'}
I2CBusSpeed: 100000
```

Supported peripherals

By default, SPI is disabled and `AvailableSPIChannels` does not show any channels.

Enable SPI and get the channels.

```
enableSPI(mypi);
mypi.AvailableSPIChannels
```

```
ans =
```

```
'CE0' 'CE1'
```

Show the location of the SPI pins, GPIO 10 (SPI0\_MOSI), GPIO 9 (SPI0\_MISO), and GPIO 11 (SPI0\_SCLK), on the GPIO header.

```
showPins(mypi)
```

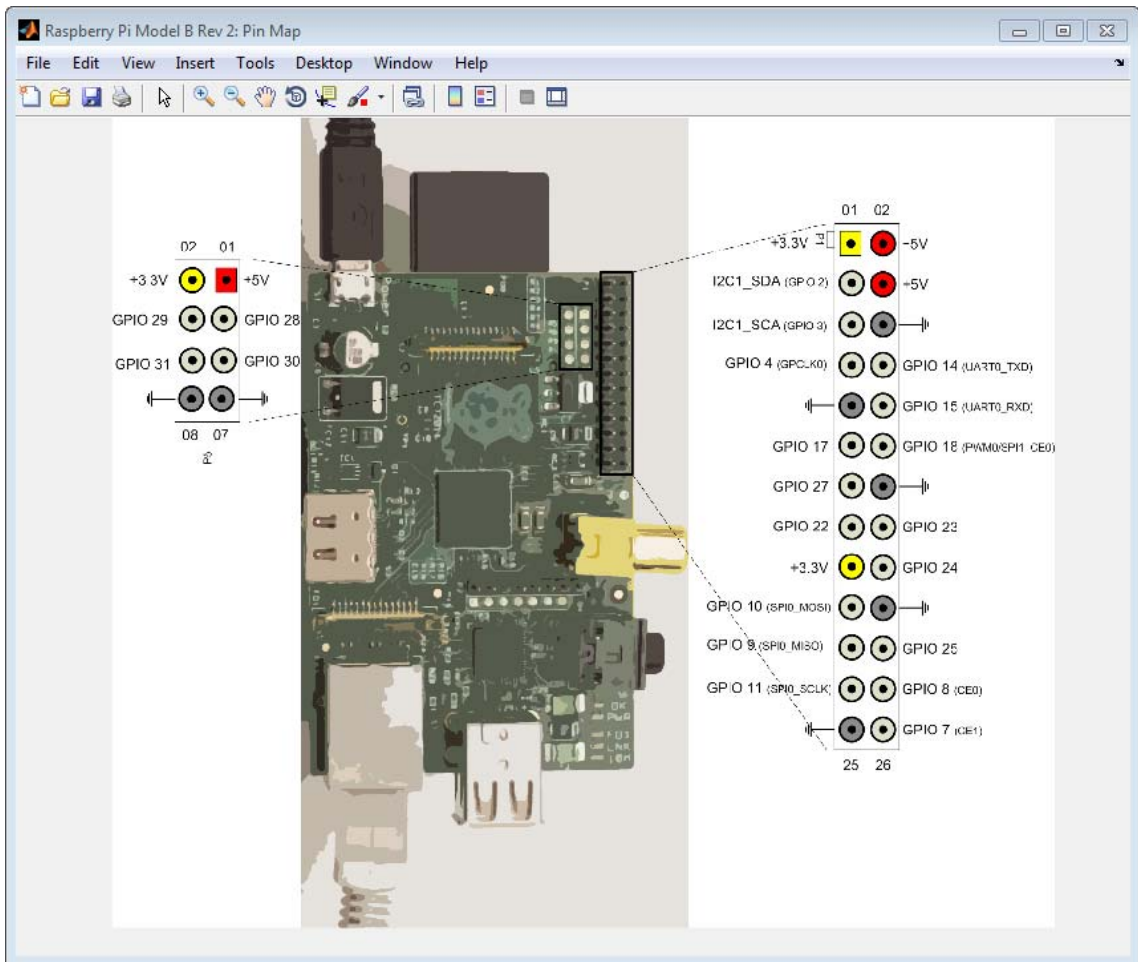

After physically connecting your SPI device to the three SPI pins, connect to the SPI device.

```
myspidevice = spidev(my_pi, 'CE1', 0)
```

```
myspidevice =
```

# enableSPI

---

```
Spidev with Properties:
 Channel: 'CE1'
 Mode: 0
 BitsPerWord: 8
 Speed: 500000
```

Write data to, and read data from, the SPI device.

```
out = writeRead(myspidevice,[hex2dec('08') hex2dec('D4')])
```

```
out =
 7 211
```

If you are not using SPI, disable SPI to make additional GPIO pins available.

```
disableSPI(mypi)
```

## See Also

[raspi](#) | [spidev](#) | [writeRead](#) | [disableSPI](#) | “Raspberry Pi Hardware”

## Related Examples

- “Open Interactive Examples”

<b>Purpose</b>	Transfer file from Raspberry Pi hardware to host computer
<b>Syntax</b>	<pre>getFile(myPi,source) getFile(myPi,source,destination)</pre>
<b>Description</b>	<p>getFile(myPi,source) copies the specified file from the Raspberry Pi hardware to the MATLAB Current Folder. Wildcards are supported.</p> <p>getFile(myPi,source,destination) copies the file to a destination path and optional file name.</p>
<b>Input Arguments</b>	<p><b>myPi - Connection to specific board</b>  handle  Connection to a specific board, specified as a handle.  Use raspi to create this connection.  <b>Example:</b> myPi</p> <p><b>source - Path and name of file on Raspberry Pi hardware</b>  path and name file name  Path and file name on the Raspberry Pi hardware, specified as a string. You can use either the absolute path from the root folder, the relative path from the present working folder. Use Linux path and file naming conventions. The default path is /home/pi/.  <b>Example:</b> '.profile'  <b>Example:</b> '/home/pi/.profile'  <b>Example:</b> '/home/pi/.pro*'</p> <p><b>Data Types</b>  char</p> <p><b>destination - Path and name of file on host computer</b>  MATLAB Current Folder (default)   destination path</p>

Path and name of file on host computer, specified as a string. If not specified, `getFile` uses the MATLAB Current Folder and the current file name. Use naming conventions of the operating system on the host computer. This function does not create new folders. Folder names in the path must already exist. Optional.

**Example:** `'C:\Users\myusername\Desktop'`

## Data Types

char

## Examples

### Download a File to the MATLAB Current Folder

You can copy a file, such as `.profile`, from the Raspberry Pi hardware to the MATLAB Current Folder on your host computer.

```
getFile(myip, '/home/pi/.profile')
```

### Download Multiple Files to a Specific Folder on Your Host Computer

You can use a wildcard to copy any matching file or files from the Raspberry Pi hardware to your host computer. You can specify the path of a destination folder. The folder must already exist.

```
getFile(myip, '/home/pi/*.png', 'C:\Users\myusername\Desktop')
```

### Use the Camera Board

You can create a connection to the Camera Board, take a photograph, and record video.

Create a connection to the Raspberry Pi board.

```
myip = raspi;
```

Create a connection to the Camera Board while changing the resolution, and assign that connection to a handle, `mycam`. The handle displays the Camera Board properties.

```
mycam = cameraboard(myip, 'Resolution', '1280x720')
```



```
mycam =
```

```
Cameraboard with Properties:
```

```
 Name: Camera Board
 Resolution: '1280x720' (View available resolutions)
 Quality: 10 (1 to 100)
 Rotation: 0 (0, 90, 180 or 270)
HorizontalFlip: 0
VerticalFlip: 0
 FrameRate: 30 (2 to 30)
 Recording: 0

Picture Settings
 Brightness: 50 (0 to 100)
 Contrast: 0 (-100 to 100)
 Saturation: 0 (-100 to 100)
 Sharpness: 0 (-100 to 100)

Exposure and AWB
 ExposureMode: 'auto' (View available exposure modes)
 ExposureCompensation: 0 (-10 to 10)
 AWBMode: 'auto' (View available AWB modes)
 MeteringMode: 'average' (View available metering modes)

Effects
 ImageEffect: 'none' (View available image effects)
 VideoStabilization: 'off'
 ROI: [0.00 0.00 1.00 1.00] (0.0 to 1.0 [top, left, width, height])
```

Import and display a sequence of ten snapshots on your host computer.

```
for ii = 1:10
img = snapshot(mycam);
imagesc(img);
drawnow;
end
```

If the image is upside down, change the orientation of the image.

```
mycam.Rotation = 180;
```

You can use the same approach to change the values of many mycamera properties listed in the "Name-Value Pair Arguments" for cameraboard.

Record a 60 second video.

```
record(mycam, 'myvideo.mp4', 60)
```

Stop recording before the 60 seconds have elapsed.

```
stop(mycam)
```

Copy the video from the board to your host computer.

```
getFile(mypi, 'myvideo.mp4', 'C:\MATLAB')
```

Delete the video file from the board to free up space.

```
deleteFile(mypi, 'myvideo.mp4')
```

```
system | openShell | putFile | deleteFile | cameraboard
```

## See Also

## Related Examples

- “Open Interactive Examples”

## External Web Sites

- [http://elinux.org/CLI\\_Spells](http://elinux.org/CLI_Spells)
- [http://linuxcommand.org/learning\\_the\\_shell.php](http://linuxcommand.org/learning_the_shell.php)

---

<b>Purpose</b>	Create connection to I2C device
<b>Syntax</b>	<code>myi2cdevice = i2cdev(myipi,bus,i2cAddress)</code>
<b>Description</b>	<code>myi2cdevice = i2cdev(myipi,bus,i2cAddress)</code> connects to an I2C device and returns a handle, <code>myi2cdevice</code> . You can exchange data with the I2C device by using <code>myi2cdevice</code> with the <code>read</code> , <code>write</code> , <code>readRegister</code> , and <code>writeRegister</code> methods. You can use <code>myi2cdevice</code> to read properties of the I2C device.
<b>Input Arguments</b>	<p><b>myipi - Connection to specific board</b> handle Connection to a specific board, specified as a handle. Use <code>raspi</code> to create this connection. <b>Example:</b> <code>myipi</code></p> <p><b>bus - I2C bus</b> '2c-0'   '2c-1' I2C bus, specified as a string. <b>Example:</b> 'i2c-1'</p> <p><b>Data Types</b> char</p> <p><b>i2cAddress - I2C device address</b> hexadecimal address I2C device address, specified as a string. Use <code>scanI2Cbus</code> to get a list of addresses. The address is a Hexadecimal value. <b>Example:</b> '0x20'</p> <p><b>Data Types</b> char</p>

## Output Arguments

### **myi2cdevice - Connection to specific I2C device**

`handle`

Connection to a specific I2C device, specified as a handle.

You can use `myi2cdevice` with the following methods:

- `read`
- `write`
- `readRegister`
- `writeRegister`

You can read values from the following `myi2cdevice` properties:

- `Bus`
- `I2CAddress`

## Examples

### **Connect and Exchange Data with I2C Devices**

You can connect and exchange data with a pair of I2C devices.

Create a connection to the Raspberry Pi board.

```
mypi = raspi
```

```
mypi =
```

```
Raspi with Properties:
```

```
DeviceAddress: 'raspberrypi-computername'
Port: 18725
BoardName: 'Raspberry Pi Model B Rev 2'
AvailableLEDs: {'led0'}
AvailableDigitalPins: [4 7 8 9 10 11 14 15 17 18 22 23 24 25 27 30 31]
AvailableSPIChannels: {}
AvailableI2CBuses: {'i2c-0' 'i2c-1'}
I2CBusSpeed: 100000
```

Supported peripherals

Redisplay AvailableI2CBuses and I2CBusSpeed.

```
mypi.AvailableI2CBuses
mypi.I2CBusSpeed
```

```
ans =
```

```
 'i2c-0' 'i2c-1'
```

```
ans =
```

```
 100000
```

Show the location of the I2C pins.

```
showPins(mypi)
```

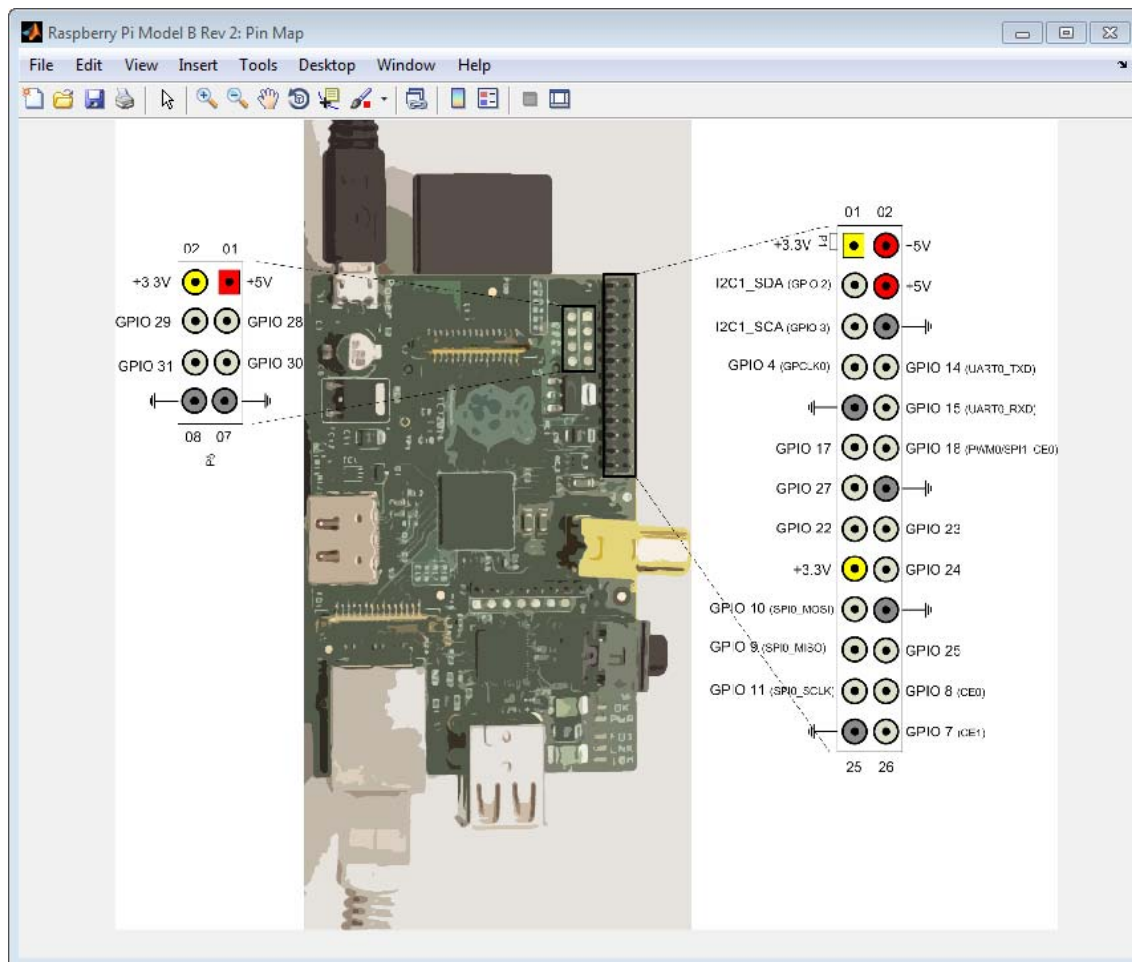

The pin map shows that, for this model and revision of the board, the i2c-1 bus is available on the GPIO header pins I2C1\_SDA (GPIO 2) and I2C1\_SCL (GPIO 3).

After physically connecting your I2C device to the I2C pins, get the addresses of I2C devices attached to the I2C bus, 'i2c-1'.

```
scanI2CBus(mypi, 'i2c-1')
```

```
ans =
```

```
 {'0x55', '0x20'}
```

Create a connection to the I2C sensor at '0x20' and assign that connection to a handle, `i2csensor`.

```
i2csensor = i2cdev(mypi, 'i2c-1', '0x20')
```

```
i2csensor =
```

```
I2C with Properties:
```

```
 Bus: i2c-1
```

```
 I2CAddress: 0x20
```

```
 TimeOut: 10
```

Read two `uint8` numbers from the sensor.

```
output1 = read(i2csensor, 2);
```

Read the value of register 14 from the sensor

```
output2 = readRegister(i2csensor, 14);
```

Create a connection to the I2C LED display at '0x55' and assign that connection to a handle, `i2cdisplay`.

```
i2cdisplay = i2cdev(mypi, 'i2c-1', '0x55')
```

```
i2cdisplay =
```

```
I2C with Properties:
```

```
 Bus: i2c-1
```

```
 I2CAddress: 0x55
```

```
 TimeOut: 10
```

Write characters to the display.

```
write(i2cdisplay,[hex2dec('20') hex2dec('51')]);
```

Write a scalar hexadecimal value, `hex2dec('08')`, to register 3 on an I2C device.

```
writeRegister(i2cdisplay,3,hex2dec('08'),'uint8');
```

If you are not using I2C, disable I2C to make additional GPIO pins available.

```
disableI2C(mypi)
```

When you use I2C again, enable I2C.

```
enableI2C(mypi)
```

You can only change the `mypi.I2CBusSpeed` property when you enable I2C.

```
disableI2C(mypi);
enableI2C(mypi,400000);
mypi.I2CBusSpeed
```

```
ans =
```

```
40000
```

## See Also

[scanI2CBus](#) | [read](#) | [write](#) | [readRegister](#) | [writeRegister](#) | [enableI2C](#) | [disableI2C](#) | [raspi](#) | “Raspberry Pi Hardware”

## Related Examples

- “Open Interactive Examples”



---

<b>Purpose</b>	Open terminal on host computer to use Linux shell on Raspberry Pi hardware
<b>Syntax</b>	<code>openShell(myPi)</code>
<b>Description</b>	<code>openShell(myPi)</code> opens an SSH terminal on your host computer that provides encrypted access to the Linux command shell on the Raspberry Pi hardware. When you are prompted, enter a user name and password. The default user name and password are <code>pi</code> and <code>raspberry</code> .
<b>Input Arguments</b>	<p><b>myPi - Connection to specific board</b></p> <p><code>handle</code></p> <p>Connection to a specific board, specified as a handle.</p> <p>Use <code>raspi</code> to create this connection.</p> <p><b>Example:</b> <code>myPi</code></p>
<b>Examples</b>	<p><b>Change Passwords Using a SSH Terminal</b></p> <p>You can use an encrypted SSH terminal session to change the password on your Raspberry Pi board.</p> <p>It is a good security practice to immediately change the default password to a secure one the first time you connect to the Raspberry Pi board.</p> <pre>myPi = raspi() openShell(myPi)</pre>

# openShell

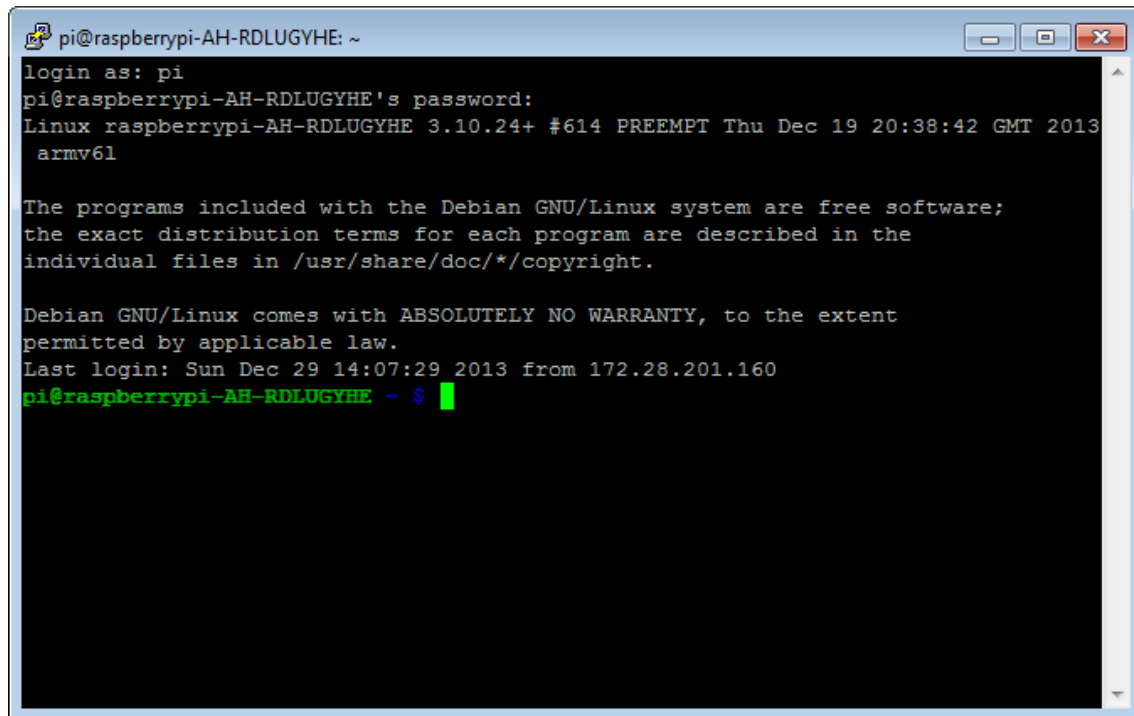

```
pi@raspberrypi-AH-RDLUGYHE: ~
login as: pi
pi@raspberrypi-AH-RDLUGYHE's password:
Linux raspberrypi-AH-RDLUGYHE 3.10.24+ #614 PREEMPT Thu Dec 19 20:38:42 GMT 2013
armv6l

The programs included with the Debian GNU/Linux system are free software;
the exact distribution terms for each program are described in the
individual files in /usr/share/doc/*/copyright.

Debian GNU/Linux comes with ABSOLUTELY NO WARRANTY, to the extent
permitted by applicable law.
Last login: Sun Dec 29 14:07:29 2013 from 172.28.201.160
pi@raspberrypi-AH-RDLUGYHE ~ $
```

Start the raspi-config utility.

```
sudo raspi-config
```

Select 2 Change User Password and change the default password to a secure one.

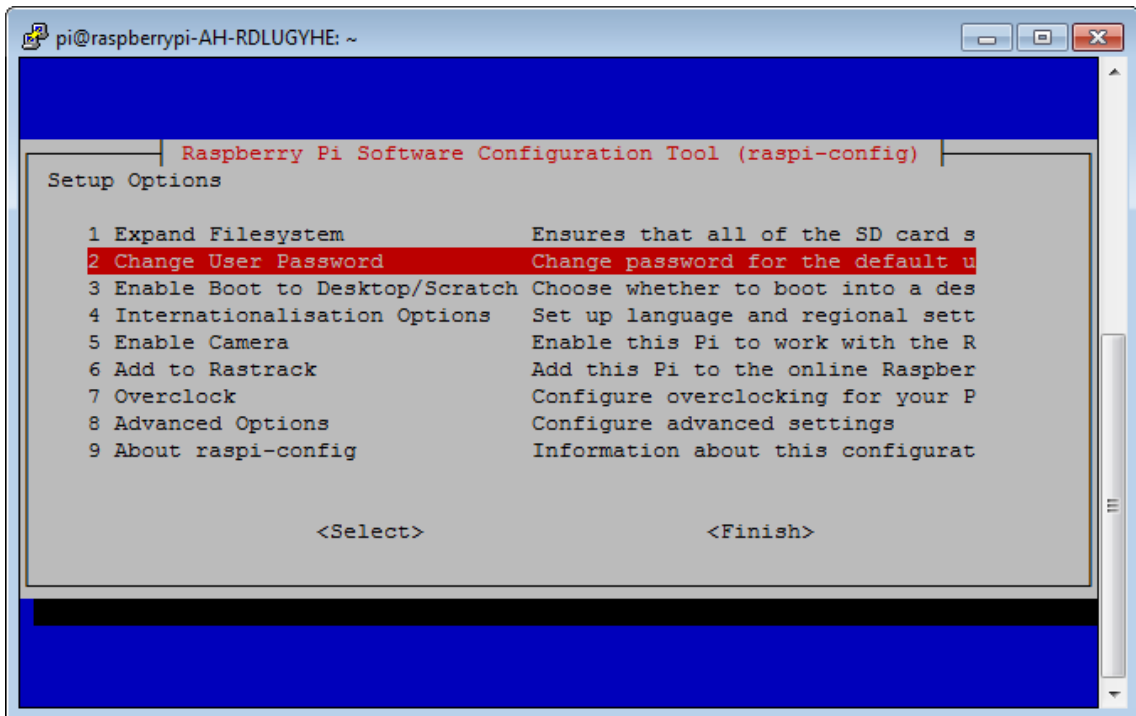

```
pi@raspberrypi-AH-RDLUGYHE: ~
Raspberry Pi Software Configuration Tool (raspi-config)
Setup Options

1 Expand Filesystem Ensures that all of the SD card s
2 Change User Password Change password for the default u
3 Enable Boot to Desktop/Scratch Choose whether to boot into a des
4 Internationalisation Options Set up language and regional sett
5 Enable Camera Enable this Pi to work with the R
6 Add to Rastrack Add this Pi to the online Raspber
7 Overclock Configure overclocking for your P
8 Advanced Options Configure advanced settings
9 About raspi-config Information about this configurat

 <Select> <Finish>
```

**See Also**            system | getFile | putFile | deleteFile | “Linux”

**Related Examples**

- “Open Interactive Examples”

**External Web Sites**

- [http://en.wikipedia.org/wiki/Secure\\_Shell](http://en.wikipedia.org/wiki/Secure_Shell)
- [http://elinux.org/CLI\\_Spells](http://elinux.org/CLI_Spells)
- [http://linuxcommand.org/learning\\_the\\_shell.php](http://linuxcommand.org/learning_the_shell.php)

# putFile

---

**Purpose** Transfer file from host computer to target hardware

**Syntax** `putFile(my_pi, source)`  
`putFile(my_pi, source, destination)`

**Description** `putFile(my_pi, source)` copies the specified file from the MATLAB Current Folder to the current folder (`pwd`) on the Raspberry Pi hardware. Wildcards are supported.

`putFile(my_pi, source, destination)` copies the file to a destination path and optional file name.

## Input Arguments

### **my\_pi - Connection to specific board**

handle

Connection to a specific board, specified as a handle.

Use `raspi` to create this connection.

**Example:** `my_pi`

### **source - Path and name of file on host computer**

MATLAB Current Folder (default) | source path

Path and name of the file on the host computer. Specify the path as a string. You can use an absolute path or a relative path from the MATLAB Current Folder. Use the path and file naming conventions of the operating system on your host computer.

**Example:** `'C:\Work\.profile'`

### **Data Types**

char

### **destination - Destination folder path and optional file name**

destination path

Destination folder path and optional file name, specified as a string. Use Linux path and file naming conventions. Optional.

**Example:**  `'/home/pi/.profile'`

## Data Types

char

## Examples

### Upload a File to the Raspberry Pi Hardware

You can copy a file, such as `out.jpg`, from your host computer to the Raspberry Pi hardware. Use the different file and path conventions of each operating system.

```
putFile(myPi, 'C:\Work\.profile', '/home/pi/.profile');
```

## See Also

`system` | `openShell` | `getFile` | `deleteFile`

## Related Examples

- “Open Interactive Examples”

## External Web Sites

- [http://elinux.org/CLI\\_Spells](http://elinux.org/CLI_Spells)
- [http://linuxcommand.org/learning\\_the\\_shell.php](http://linuxcommand.org/learning_the_shell.php)

# raspi

---

**Purpose** Create connection to Raspberry Pi hardware

**Syntax**  
`mypi = raspi`  
`mypi = raspi(ipaddress,username,password)`

**Description** `mypi = raspi` creates a connection to the Raspberry Pi board and assigns that connection to a handle. Use this syntax to simply connect or reconnect to the same board.

You do not need to supply the user IP address, user name, and password because `raspi` reuses these settings from the most recent successful connection to a Raspberry Pi board, including the setup process.

After connecting to the board, you can use `mypi` to interact with the Raspberry Pi board and peripheral devices.

To close the connection, use `clear` to remove `mypi` and any other handles that were created using `mypi`.

`mypi = raspi(ipaddress,username,password)` overrides the IP address, user name, and password from the previous connection. Use this syntax to connect to a board whose settings are different from the previous successful connection. Use this syntax after changing the password on a board, or to create a connection to a second board.

---

**Note** The firmware has a default user name, 'pi', and password, 'raspberry'. The pi user has sudo root powers on the command line. It is a good security practice to change the default password to a strong password.

---

**Input Arguments** **ipaddress - IP address or host name of board**  
valid IPv4 address | valid host name

IP address or host name of the board, specified as a string.

**Example:** '169.254.0.2'

---

**Example:** 'raspberrypi-computername'

### Data Types

char

### username - Linux user name

user name

Linux user name, specified as a string.

**Example:** 'pi'

### Data Types

char

### password - Linux user password

password

Linux user password, specified as a string.

---

**Note** The firmware has a default user name, 'pi', and password, 'raspberry'. This user has sudo root powers on the command line. It is a good security practice to change this default password to a strong password.

---

**Example:** 'raspberry'

### Data Types

char

## Output Arguments

### mypi - Connection to specific board

handle

Connection to a specific board, specified as a handle.

You can use `mypi` to connect to add-on peripherals using:

- `serialdev`
- `i2cdev`

- `spidev`
- `cameraboard`

You can use `mypi` with the following methods:

- `configureDigitalPin`
- `readDigitalPin`
- `writeDigitalPin`
- `showPins`
- `writeLED`
- `showLEDs`
- `scanI2Cbus`
- `enableI2C`
- `disableI2C`
- `enableSPI`
- `disableSPI`
- `system`
- `openShell`
- `getFile`
- `putFile`
- `deleteFile`

You can use `mypi` to read the following properties for the Raspberry Pi hardware:

- `DeviceAddress` — IP address or host name
- `Port` — IP port number used for TCP/IP connections
- `BoardName` — Board, model, and revision
- `AvailableLEDs` — Available LEDs



- `AvailableDigitalPins` — Numbers of the available GPIO pins
- `AvailableSPIChannels` — Names of the available SPI channels
- `AvailableI2CBuses` — Names of the available I2C buses
- `I2CBusSpeed` — Speed of the I2C buses

## Examples

### Create a Connection to a Raspberry Pi Board

You can create a connection from the MATLAB software on your host computer to a Raspberry Pi board.

When you create the connection, assign it to a handle. You can use this handle later on to interact with the Raspberry Pi hardware.

You do not need to supply the user IP address, user name, and password because `raspi` reuses these settings from the most recent successful connection to a Raspberry Pi board, including the setup process.

Create a connection and assign it to a handle, `mypi`.

```
mypi = raspi
```

```
mypi =
```

```
Raspi with Properties:
```

```

 DeviceAddress: 'raspberrypi-computername'
 Port: 18725
 BoardName: 'Raspberry Pi Model B Rev 2'
 AvailableLEDs: {'led0'}
AvailableDigitalPins: [4 7 8 9 10 11 14 15 17 18 22 23 24 25 27 30 31]
AvailableSPIChannels: {}
 AvailableI2CBuses: {'i2c-0' 'i2c-1'}
 I2CBusSpeed: 100000

```

```
Supported peripherals
```

Use `mypi` to create a connection to a serial device.

```
myserialdevice = serialdev(mypi, '/dev/ttyAMA0');
```

To close the connection, use `clear` to remove `mypi` and any other handles that were created using `mypi`.

```
clear mypi;
clear myserialdevice;
```

## Create a Connection to a Board That Has Different Settings

You can create a connection to a Raspberry Pi board that has a different IP address, user name, and password from the previous successful connection.

Follow this example to reconnect to a board after you change its settings, or to connect to multiple boards concurrently.

```
mysecondpi = raspi('169.254.0.4', 'rocky', 'bullwinkle')
```

```
mysecondpi =
```

```
Raspi with Properties:
```

```
 DeviceAddress: '169.254.0.4'
 Port: 18725
 BoardName: 'Raspberry Pi Model B Rev 2'
 AvailableLEDs: {'led0'}
AvailableDigitalPins: [4 7 8 9 10 11 14 15 17 18 22 23 24 25 27 30 31]
AvailableSPIChannels: {}
 AvailableI2CBuses: {'i2c-0' 'i2c-1'}
 I2CBusSpeed: 100000
```

```
Supported peripherals
```

## Create a Connection Using a Host Name

You can use a host name, instead of an IP address, to create a connection to a Raspberry Pi board.

During the setup process, Support Package Installer generated the Raspberry Pi host name by appending the name of your computer to raspberrypi-.

```
mysecondpi = raspi('raspberrypi-computername')
```

```
mysecondpi =
```

```
Raspi with Properties:
```

```
 DeviceAddress: 'raspberrypi-computername'
 Port: 18725
 BoardName: 'Raspberry Pi Model B Rev 2'
 AvailableLEDs: {'led0'}
AvailableDigitalPins: [4 7 8 9 10 11 14 15 17 18 22 23 24 25 27 30 31]
AvailableSPIChannels: {}
 AvailableI2CBuses: {'i2c-0' 'i2c-1'}
 I2CBusSpeed: 100000
```

```
Supported peripherals
```

The `DeviceAddress` reflects whether a host name or IP address was used to create the connection.

**See Also** “Raspberry Pi Hardware”

## Related Examples

- “Open Interactive Examples”

# raspi\_examples

---

**Purpose** Open featured examples for this support package

**Syntax** `raspi_examples`

**Description** `raspi_examples` opens the featured examples that are installed with the MATLAB Support Package for Raspberry Pi Hardware.

**Examples** **Open the Featured Examples for MATLAB Support for Raspberry Pi**

In the MATLAB Command Window, enter:

```
raspi_examples
```

A window opens and displays the examples.

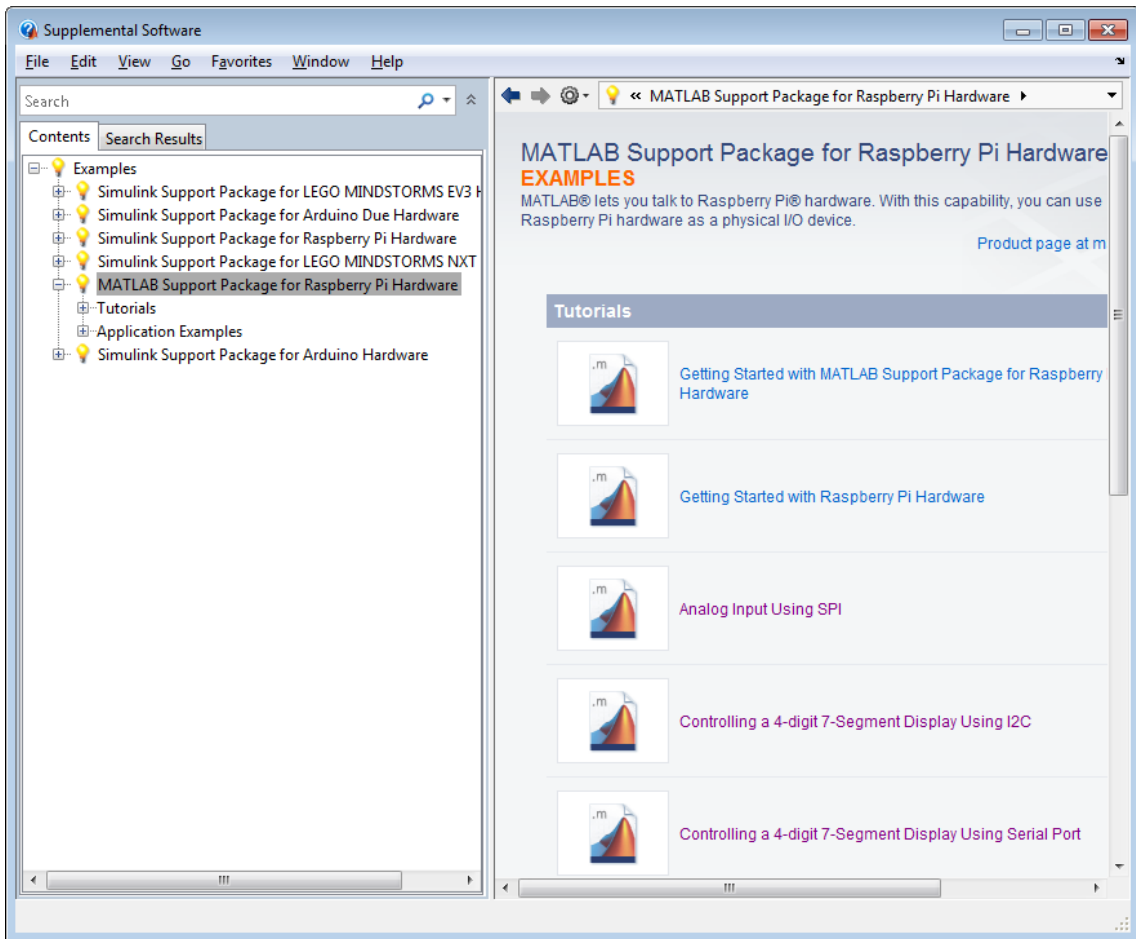

**See Also** “Raspberry Pi Hardware”

## Related Examples

- “Open Interactive Examples”

# read

---

## Purpose

Read data from I2C device

## Syntax

```
[data] = read(myi2cdevice, count, dataPrecision)
```

## Description

[data] = read(myi2cdevice, count, dataPrecision) returns data from the I2C device as a row vector.

The read method stops when it finishes reading the specified data from the device, or when the timeout period elapses.

## Input Arguments

### **myi2cdevice - Connection to I2C device**

handle

Connection to I2C device, specified as a handle.

Use `i2cdev` to create this connection.

**Example:** `myi2cdevice`

### **count - Size of I2C data**

size of I2C data

Size of I2C data, specified as a scalar. This value is the number of data elements that you expect.

**Example:** `2`

### **Data Types**

`int8` | `int16` | `uint8` | `uint16`

### **dataPrecision - Data precision**

`'uint8 (default)'` | `'int8'` | `'int16'` | `'uint16'`

Data precision, specified as a string. Match the data precision to the size of the register on the device. Optional.

**Example:** `'int16'`

### **Data Types**

`char`

## Output Arguments

### **data - vector of numeric values**

data

Data from the I2C device, returned as a row vector. The number of elements of the row vector is specified by the count argument.

## Examples

### **Connect and Exchange Data with I2C Devices**

You can connect and exchange data with a pair of I2C devices.

Create a connection to the Raspberry Pi board.

```
mypi = raspi
```

```
mypi =
```

```
Raspi with Properties:
```

```
 DeviceAddress: 'raspberrypi-computername'
 Port: 18725
 BoardName: 'Raspberry Pi Model B Rev 2'
 AvailableLEDs: {'led0'}
AvailableDigitalPins: [4 7 8 9 10 11 14 15 17 18 22 23 24 25 27 30 31]
AvailableSPIChannels: {}
 AvailableI2CBuses: {'i2c-0' 'i2c-1'}
 I2CBusSpeed: 100000
```

```
Supported peripherals
```

Redisplay AvailableI2CBuses and I2CBusSpeed.

```
mypi.AvailableI2CBuses
```

```
mypi.I2CBusSpeed
```

```
ans =
```

```
 'i2c-0' 'i2c-1'
```

# read

---

```
ans =
```

```
100000
```

Show the location of the I2C pins.

```
showPins(myPi)
```



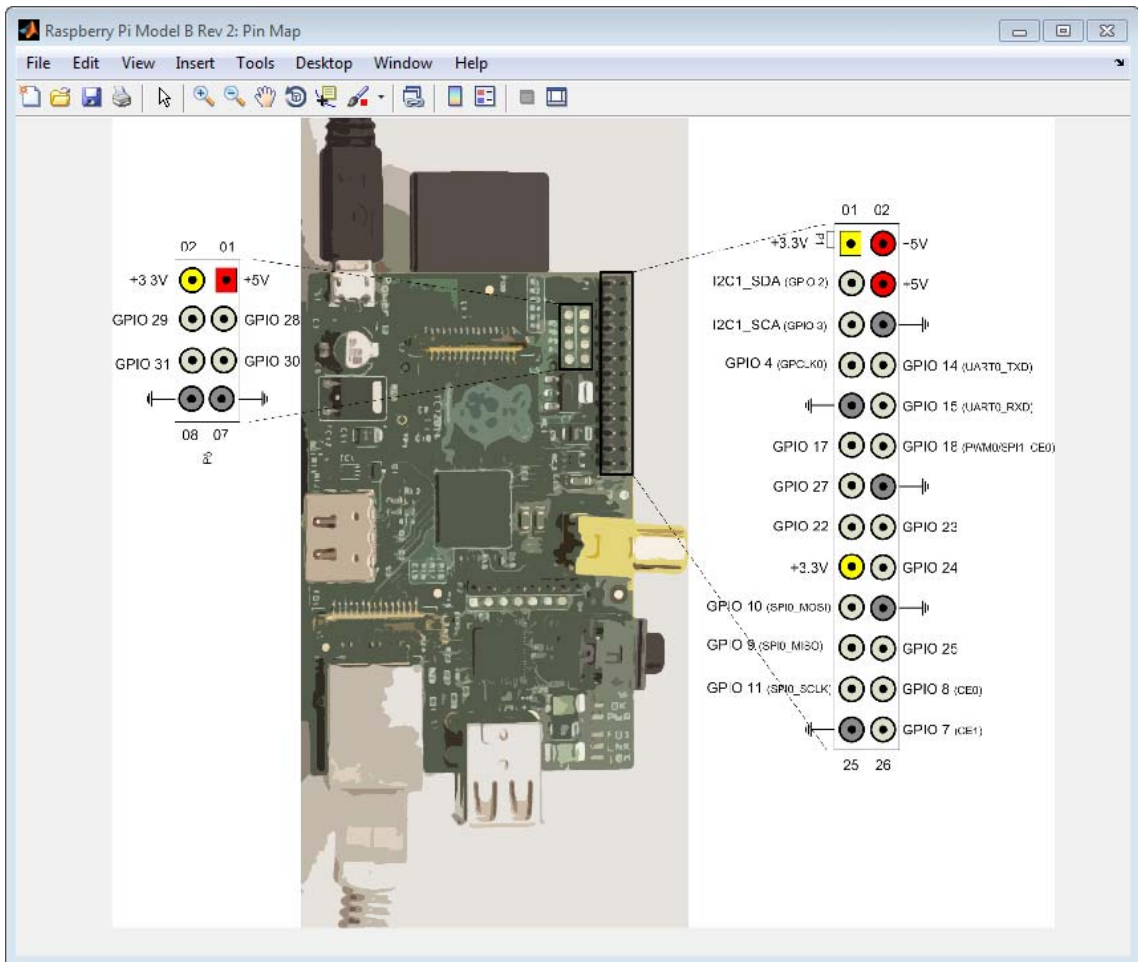

The pin map shows that, for this model and revision of the board, the i2c-1 bus is available on the GPIO header pins I2C1\_SDA (GPIO 2) and I2C1\_SCL (GPIO 3).

After physically connecting your I2C device to the I2C pins, get the addresses of I2C devices attached to the I2C bus, 'i2c-1'.

```
scanI2CBus(mypi, 'i2c-1')
```

```
ans =
```

```
 {'0x55', '0x20'}
```

Create a connection to the I2C sensor at '0x20' and assign that connection to a handle, `i2csensor`.

```
i2csensor = i2cdev(mypi, 'i2c-1', '0x20')
```

```
i2csensor =
```

```
I2C with Properties:
```

```
 Bus: i2c-1
```

```
 I2CAddress: 0x20
```

```
 TimeOut: 10
```

Read two uint8 numbers from the sensor.

```
output1 = read(i2csensor, 2);
```

Read the value of register 14 from the sensor

```
output2 = readRegister(i2csensor, 14);
```

Create a connection to the I2C LED display at '0x55' and assign that connection to a handle, `i2cdisplay`.

```
i2cdisplay = i2cdev(mypi, 'i2c-1', '0x55')
```

```
i2cdisplay =
```

```
I2C with Properties:
```

```
 Bus: i2c-1
```

```
 I2CAddress: 0x55
```

```
 TimeOut: 10
```

Write characters to the display.

```
write(i2cdisplay,[hex2dec('20') hex2dec('51')]);
```

Write a scalar hexadecimal value, `hex2dec('08')`, to register 3 on an I2C device.

```
writeRegister(i2cdisplay,3,hex2dec('08'),'uint8');
```

If you are not using I2C, disable I2C to make additional GPIO pins available.

```
disableI2C(mypi)
```

When you use I2C again, enable I2C.

```
enableI2C(mypi)
```

You can only change the `mypi.I2CBusSpeed` property when you enable I2C.

```
disableI2C(mypi);
enableI2C(mypi,400000);
mypi.I2CBusSpeed
```

```
ans =
```

```
40000
```

## See Also

[scanI2CBus](#) | [i2cdev](#) | [write](#) | [readRegister](#) | [writeRegister](#) | [enableI2C](#) | [disableI2C](#) | “Raspberry Pi Hardware”

## Related Examples

- “Open Interactive Examples”

# read

---

## Purpose

Read data from serial device

## Syntax

```
serialData = read(myserialdevice,count)
serialData = read(myserialdevice,count,precision)
```

## Description

`serialData = read(myserialdevice,count)` returns data from the serial device.

The `read` method stops when it finishes reading the specified data from the device, or when the timeout period elapses.

`serialData = read(myserialdevice,count,precision)` overrides the default value for precision.

## Input Arguments

### **myserialdevice - Connection to serial device**

handle

Connection to a serial device, specified as a handle.

Use `serialdev` to create this connection.

**Example:** `myserialdevice`

### **count - Data size**

data size

Data size to read from the serial device, specified as a scalar.

**Example:** `2`

### **Data Types**

double

### **precision - Data precision**

'uint8' (default) | 'char' | 'int8' | 'int16' | 'uint16' | 'int32' | 'uint32' | 'single' | 'double'

Data precision, specified as a string. Optional.

**Example:** `'uint8'`

**Data Types**

char

**Output Arguments****serialData - Data from serial device**

serial data

Data from the serial device, returned in the device- or user-defined format.

**Examples****Connect and Exchange Data with Serial Device**

You can create a connection to a serial device, write data to the device, and read data from the device.

Create a connection to the Raspberry Pi board.

```
mypi = raspi;
```

Show the location of the Tx and Rx pins, GPIO 14 (UART0\_TXD) and GPIO 15 (UART0\_RXD), on the GPIO header.

```
showPins(mypi)
```

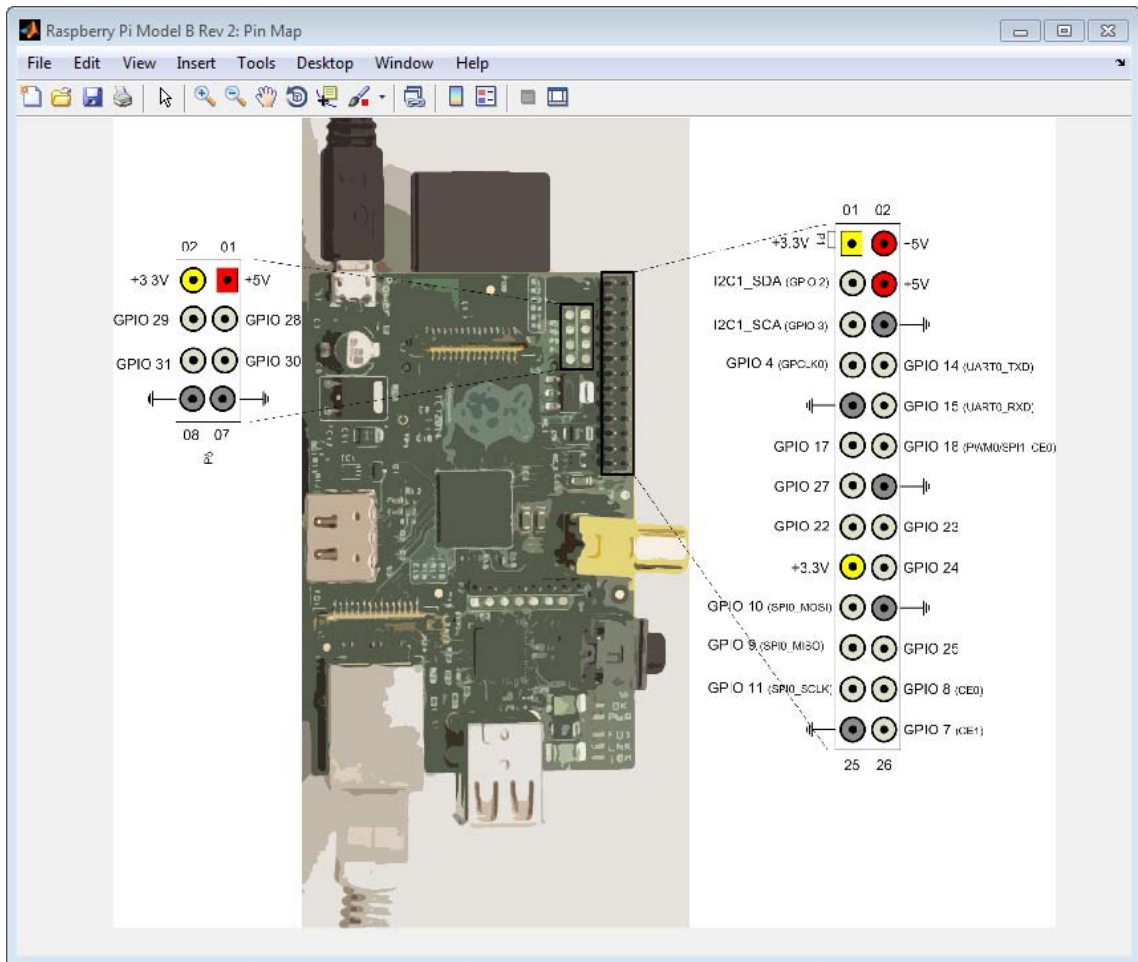

Raspberry Pi hardware uses +3.3V. Do not connect Raspberry Pi hardware directly to devices that use higher voltages.

Connect the Raspberry Pi serial port to a +3.3V serial device.

- To receive data, connect the RXD pin (GPIO 15 UART0\_RXD) on the Raspberry Pi board to the TXD pin on the serial device.

- To transmit data, connect the TXD pin (GPIO 14 UART0\_TXD) on the Raspberry Pi board to the RXD pin on the serial device.
- Connect a ground pins (GND) on the Raspberry Pi board to the GND pin on the serial device.
- Connect one of the +3.3V pins on the Raspberry Pi board to the VCC pin on the serial device.

Research the values the serial device requires for the baud rate, data bits, parity, and stop bit.

Use `serialdev` to create a connection to the serial device and assign the connection to a handle.

```
myserialdevice = serialdev(mypi, '/dev/ttyAMA0', 9600)
```

```
myserialdevice =
```

```
 Serialdev with Properties:
```

```
 BaudRate: 9600
 DataBits: 8
 Parity: 'none'
 StopBits: 1
 Timeout: 10
```

Write a pair of values to a serial device that requires a specific data type.

```
write(myserialdevice, [10 12], 'uint16')
```

Read a 100-element array of numbers from the serial port.

```
output = read(myserialdevice, 100, 'uint16');
```

Increase the timeout period of the serial port.

```
myserialdevice.Timeout = 20
```

```
myserialdevice =
```

# read

---

Serialdev with Properties:

```
BaudRate: 115200
DataBits: 8
 Parity: 'none'
StopBits: 1
Timeout: 20
```

## See Also

[serialdev](#) | [write](#) | [showPins](#) | “Raspberry Pi Hardware”

## Related Examples

- “Open Interactive Examples”



## Purpose

Read logical value from GPIO input pin

## Syntax

```
pinvalue = readDigitalPin(myPi, pinNumber)
```

## Description

`pinvalue = readDigitalPin(myPi, pinNumber)` returns the logical value of a digital pin.

This method configures an unconfigured pin as a GPIO input.

If the pin is a GPIO output, or if another interface (I2C, Serial, SPI) is using the pin, this method returns an error message.

## Input Arguments

### **myPi - Connection to specific board**

handle

Connection to a specific board, specified as a handle.

Use `raspi` to create this connection.

**Example:** `myPi`

### **pinNumber - GPIO pin number**

pin number

GPIO pin number, specified as a scalar. This argument does not accept vectors because the hardware cannot access multiple pins simultaneously.

To get a list of valid pin numbers, enter `myPi.AvailableDigitalPins`.

**Example:** `12`

### **Data Types**

double

## Output Arguments

### **pinvalue - Logical value of pin**

0 | 1

Logical value of the pin, returned as a scalar.

# readDigitalPin

---

## Examples

### Configure Pin as Digital Input and Read Its Logical Value

You can configure a pin as digital input and read its logical value.

Create a connection to the Raspberry Pi board.

```
mypi = raspi
```

```
mypi =
```

```
Raspi with Properties:
```

```
 DeviceAddress: 'raspberrypi-computername'
 Port: 18725
 BoardName: 'Raspberry Pi Model B Rev 2'
 AvailableLEDs: {'led0'}
AvailableDigitalPins: [4 7 8 9 10 11 14 15 17 18 22 23 24 25 27 30 31]
AvailableSPIChannels: {}
 AvailableI2CBuses: {'i2c-0' 'i2c-1'}
 I2CBusSpeed: 100000
```

The `AvailableDigitalPins` property shows the list of digital pins that are available.

Redisplay `AvailableDigitalPins`.

```
mypi.AvailableDigitalPins
```

```
ans =
```

```
Columns 1 through 13
```

```
 4 7 8 9 10 11 14 15 17 18 22 23 24
```

```
Columns 14 through 17
```

```
 25 27 30 31
```

Show the location of the GPIO 4.

```
showPins(myPi)
```

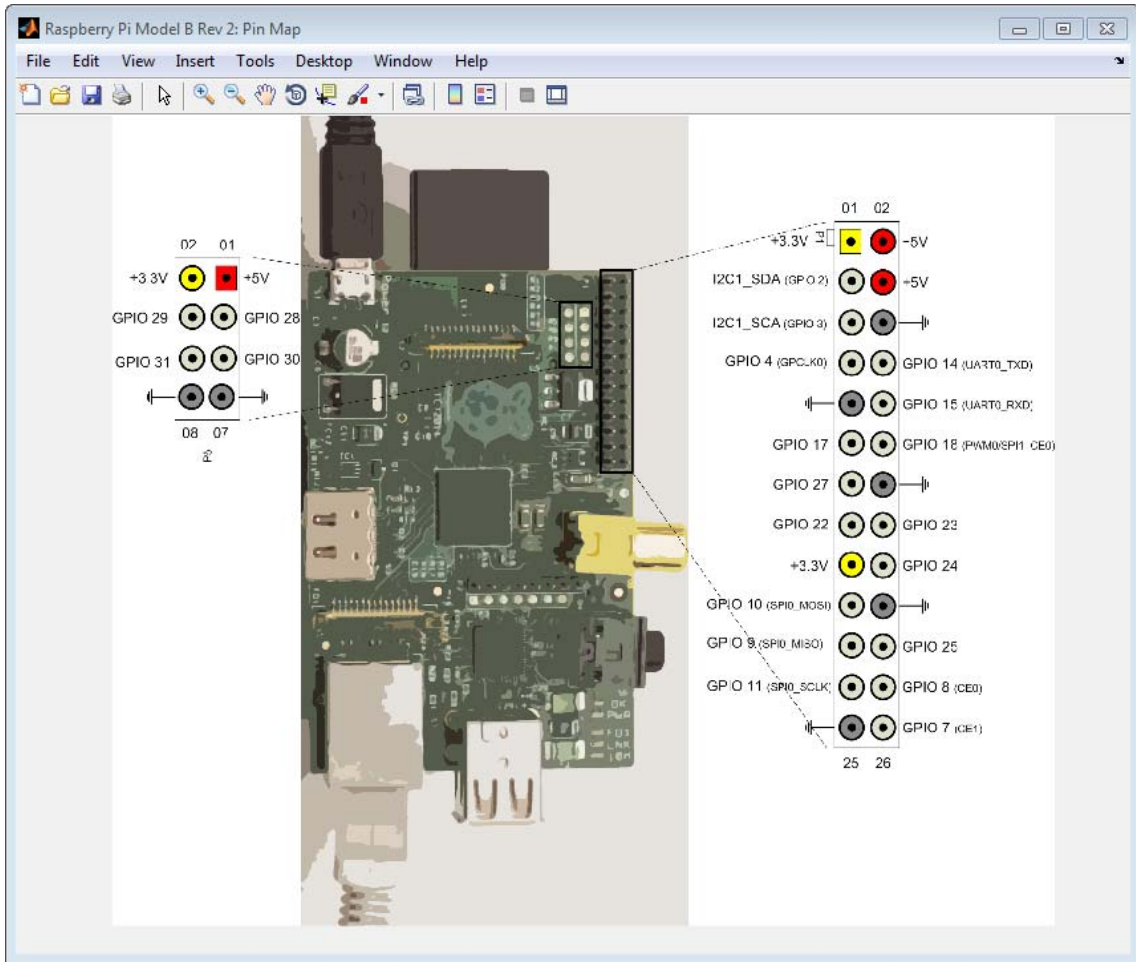

Connect the digital device you are using to GPIO 4.

Configure pin 4 as a digital input.

```
configureDigitalPin(myPi,4,'input')
```

# readDigitalPin

---

Read the value from pin 4.

```
readDigitalPin(mypi,4)
```

```
ans =
```

```
1
```

## Pressing a button blinks an LED connected to a GPIO pin

You can press a button to blink an LED connected to a GPIO pin.

This example rapidly blinks an LED when you press a button. The button connects from positive voltage to pin 23. Pressing the button closes the circuit, raising the voltage. When `readDigitalPin` detects the positive voltage, `if buttonPressed` becomes true. The program toggles the voltages to pin 24 on and off ten times. Pin 14 connects to an LED, which connects via a resistor to ground.

```
for ii = 1:100
 buttonPressed = readDigitalPin(mypi,23);
 if buttonPressed
 for jj = 1:10
 writeDigitalPin(mypi,24,1);
 pause(0.05);
 writeDigitalPin(mypi,24,0);
 pause(0.05);
 end
 end
 pause(0.1);
end
```

### See Also

`configureDigitalPin` | `writeDigitalPin` | `showPins` | `raspi` |  
“Raspberry Pi Hardware”

### Related Examples

- “Open Interactive Examples”

<b>Purpose</b>	Read from register on I2C device
<b>Syntax</b>	[value] = readRegister(myi2cdevice,register,dataPrecision)
<b>Description</b>	<p>[value] = readRegister(myi2cdevice,register,dataPrecision) returns data from the register on the I2C device as a scalar.</p> <p>The readRegister method stops when it finishes reading the specified data from the register, or when the timeout period elapses.</p>
<b>Input Arguments</b>	<p><b>myi2cdevice - Connection to I2C device</b> handle Connection to I2C device, specified as a handle. Use i2cdev to create this connection. <b>Example:</b> myi2cdevice</p> <p><b>register - I2C register number</b> I2C register number I2C register number, specified as a scalar. This number is available from the device data sheet. <b>Example:</b> 14</p> <p><b>Data Types</b> double</p> <p><b>dataPrecision - Data precision</b> 'uint8 (default)   'int8'   'int16'   'uint16' Data precision, specified as a string. Match the data precision to the size of the register on the device. Optional. <b>Example:</b> 'int16'</p> <p><b>Data Types</b> char</p>

# readRegister

---

## Output Arguments

### value - Value of register

value of register

Value of the register, returned as a scalar.

## Examples

### Connect and Exchange Data with I2C Devices

You can connect and exchange data with a pair of I2C devices.

Create a connection to the Raspberry Pi board.

```
mypi = raspi
```

```
mypi =
```

```
Raspi with Properties:
```

```
 DeviceAddress: 'raspberrypi-computername'
 Port: 18725
 BoardName: 'Raspberry Pi Model B Rev 2'
 AvailableLEDs: {'led0'}
AvailableDigitalPins: [4 7 8 9 10 11 14 15 17 18 22 23 24 25 27 30 31]
AvailableSPIChannels: {}
 AvailableI2CBuses: {'i2c-0' 'i2c-1'}
 I2CBusSpeed: 100000
```

```
Supported peripherals
```

Redisplay AvailableI2CBuses and I2CBusSpeed.

```
mypi.AvailableI2CBuses
```

```
mypi.I2CBusSpeed
```

```
ans =
```

```
 'i2c-0' 'i2c-1'
```

```
ans =
```

100000

Show the location of the I2C pins.

```
showPins(myPi)
```

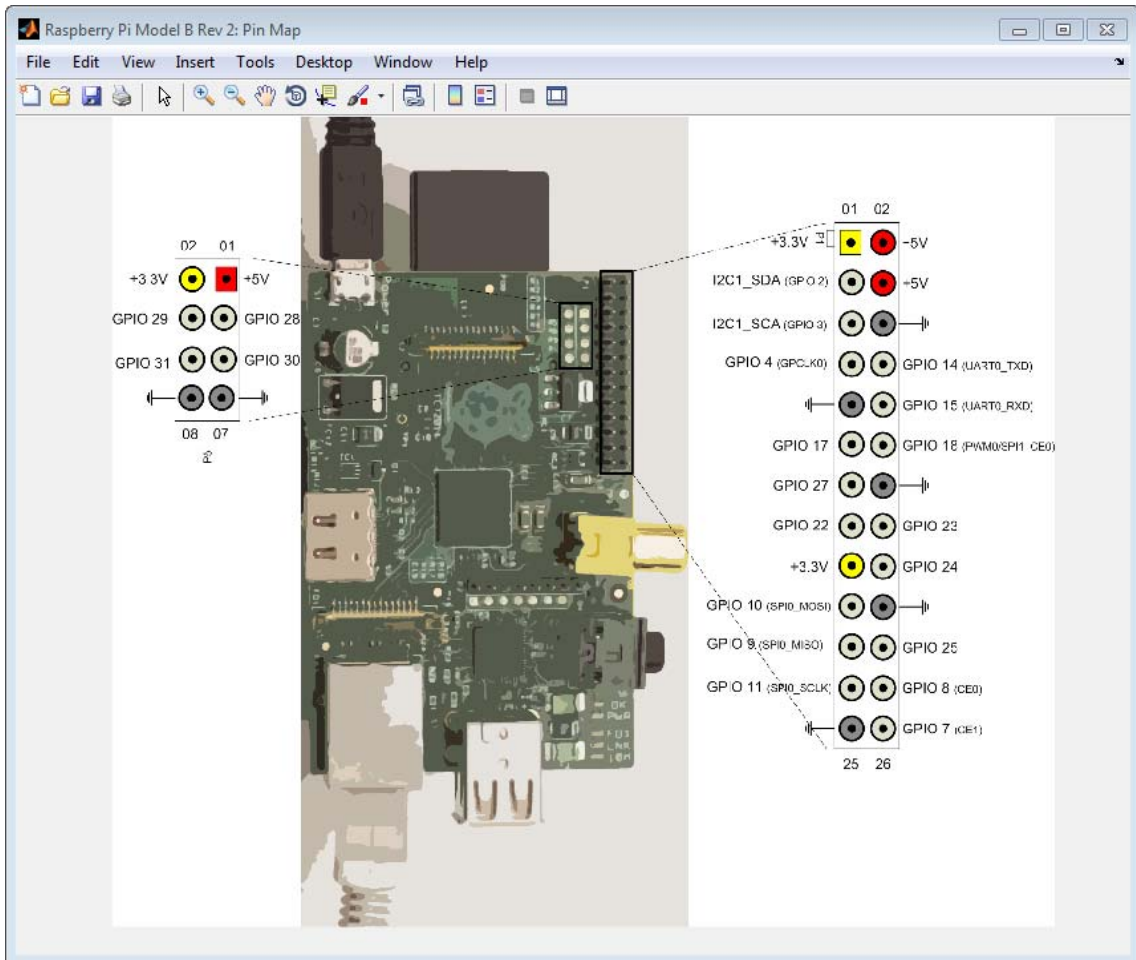

## readRegister

---

The pin map shows that, for this model and revision of the board, the `i2c-1` bus is available on the GPIO header pins `I2C1_SDA` (GPIO 2) and `I2C1_SCL` (GPIO 3).

After physically connecting your I2C device to the I2C pins, get the addresses of I2C devices attached to the I2C bus, `'i2c-1'`.

```
scanI2CBus(mypi, 'i2c-1')
```

```
ans =
```

```
 {'0x55', '0x20'}
```

Create a connection to the I2C sensor at `'0x20'` and assign that connection to a handle, `i2csensor`.

```
i2csensor = i2cdev(mypi, 'i2c-1', '0x20')
```

```
i2csensor =
```

```
I2C with Properties:
```

```
 Bus: i2c-1
```

```
 I2CAddress: 0x20
```

```
 TimeOut: 10
```

Read two `uint8` numbers from the sensor.

```
output1 = read(i2csensor,2);
```

Read the value of register 14 from the sensor

```
output2 = readRegister(i2csensor,14);
```

Create a connection to the I2C LED display at `'0x55'` and assign that connection to a handle, `i2cdisplay`.

```
i2cdisplay = i2cdev(mypi, 'i2c-1', '0x55')
```

```
i2cdisplay =
```



```
I2C with Properties:
 Bus: i2c-1
 I2CAddress: 0x55
 TimeOut: 10
```

Write characters to the display.

```
write(i2cdisplay,[hex2dec('20') hex2dec('51')]);
```

Write a scalar hexadecimal value, `hex2dec('08')`, to register 3 on an I2C device.

```
writeRegister(i2cdisplay,3,hex2dec('08'),'uint8');
```

If you are not using I2C, disable I2C to make additional GPIO pins available.

```
disableI2C(mypi)
```

When you use I2C again, enable I2C.

```
enableI2C(mypi)
```

You can only change the `mypi.I2CBusSpeed` property when you enable I2C.

```
disableI2C(mypi);
enableI2C(mypi,400000);
mypi.I2CBusSpeed
```

```
ans =
```

```
40000
```

## See Also

[scanI2Cbus](#) | [i2cdev](#) | [read](#) | [write](#) | [writeRegister](#) | [enableI2C](#) | [disableI2C](#) | “Raspberry Pi Hardware”

# readRegister

---

## Related Examples

- [“Open Interactive Examples”](#)

---

<b>Purpose</b>	Record video from Camera Board
<b>Syntax</b>	<code>record(mycamera, fileName, duration)</code>
<b>Description</b>	<code>record(mycamera, fileName, duration)</code> records video from the Camera Board to a file on Raspberry Pi.
<b>Input Arguments</b>	<p><b>mycamera - Connection to Camera Board</b> handle Connection to a Camera Board, specified as a handle. Use <code>cameraboard</code> to create this connection. <b>Example:</b> <code>mycam</code></p> <p><b>fileName - Video file name</b> video file name Video file name, specified as a string. <b>Example:</b> <code>'myvideo.mp4'</code></p> <p><b>Data Types</b> char</p> <p><b>duration - Duration of recording</b> duration of recording Duration of recording, specified in seconds. <b>Example:</b></p> <p><b>Data Types</b> double</p>
<b>Examples</b>	<p><b>Use the Camera Board</b></p> <p>You can create a connection to the Camera Board, take a photograph, and record video.</p>

Create a connection to the Raspberry Pi board.

```
mypi = raspi;
```

Create a connection to the Camera Board while changing the resolution, and assign that connection to a handle, mycam. The handle displays the Camera Board properties.

```
mycam = cameraboard(mypi, 'Resolution', '1280x720')
```

```
mycam =
```

```
Cameraboard with Properties:
```

```
 Name: Camera Board
 Resolution: '1280x720' (View available resolutions)
 Quality: 10 (1 to 100)
 Rotation: 0 (0, 90, 180 or 270)
HorizontalFlip: 0
VerticalFlip: 0
 FrameRate: 30 (2 to 30)
 Recording: 0

Picture Settings
 Brightness: 50 (0 to 100)
 Contrast: 0 (-100 to 100)
 Saturation: 0 (-100 to 100)
 Sharpness: 0 (-100 to 100)

Exposure and AWB
 ExposureMode: 'auto' (View available exposure modes)
 ExposureCompensation: 0 (-10 to 10)
 AWBMode: 'auto' (View available AWB modes)
 MeteringMode: 'average' (View available metering modes)

Effects
 ImageEffect: 'none' (View available image effects)
 VideoStabilization: 'off'
```

```
ROI: [0.00 0.00 1.00 1.00] (0.0 to 1.0 [top, left, width, height])
```

Import and display a sequence of ten snapshots on your host computer.

```
for ii = 1:10
img = snapshot(mycam);
 imagesc(img);
 drawnow;
end
```

If the image is upside down, change the orientation of the image.

```
mycam.Rotation = 180;
```

You can use the same approach to change the values of many mycamera properties listed in the "Name-Value Pair Arguments" for cameraboard.

Record a 60 second video.

```
record(mycam, 'myvideo.mp4', 60)
```

Stop recording before the 60 seconds have elapsed.

```
stop(mycam)
```

Copy the video from the board to your host computer.

```
getFile(myPi, 'myvideo.mp4', 'C:\MATLAB')
```

Delete the video file from the board to free up space.

```
deleteFile(myPi, 'myvideo.mp4')
```

## See Also

cameraboard | snapshot | stop | getFile | deleteFile | “Raspberry Pi Hardware”

## Related Examples

- “Open Interactive Examples”

## **External Web Sites**

- [RaspiCam Documentation](#)

<b>Purpose</b>	Scan I2C bus device addresses
<b>Syntax</b>	<code>[i2cAddresses] = scanI2CBus(myPi, bus)</code>
<b>Description</b>	<code>[i2cAddresses] = scanI2CBus(myPi, bus)</code> returns a list of addresses for devices that are connected to the I2C bus.
<b>Input Arguments</b>	<p><b>myPi - Connection to specific board</b> handle Connection to a specific board, specified as a handle. Use <code>raspi</code> to create this connection. <b>Example:</b> <code>myPi</code></p> <p><b>bus - I2C bus</b> '2c-0'   '2c-1' I2C bus, specified as a string. <b>Example:</b> 'i2c-1'</p> <p><b>Data Types</b> char</p>
<b>Output Arguments</b>	<p><b>i2cAddresses - I2C device addresses</b> I2C device addresses I2C device addresses, returned as a cell of hex values.</p>
<b>Examples</b>	<p><b>Connect and Exchange Data with I2C Devices</b> You can connect and exchange data with a pair of I2C devices. Create a connection to the Raspberry Pi board.</p> <pre>myPi = raspi</pre> <pre>myPi =</pre>

# scanI2CBus

---

Raspi with Properties:

```
DeviceAddress: 'raspberrypi-computername'
Port: 18725
BoardName: 'Raspberry Pi Model B Rev 2'
AvailableLEDs: {'led0'}
AvailableDigitalPins: [4 7 8 9 10 11 14 15 17 18 22 23 24 25 27 30 31]
AvailableSPIChannels: {}
AvailableI2CBuses: {'i2c-0' 'i2c-1'}
I2CBusSpeed: 100000
```

Supported peripherals

Redisplay AvailableI2CBuses and I2CBusSpeed.

```
mypi.AvailableI2CBuses
mypi.I2CBusSpeed
```

```
ans =
```

```
'i2c-0' 'i2c-1'
```

```
ans =
```

```
100000
```

Show the location of the I2C pins.

```
showPins(mypi)
```



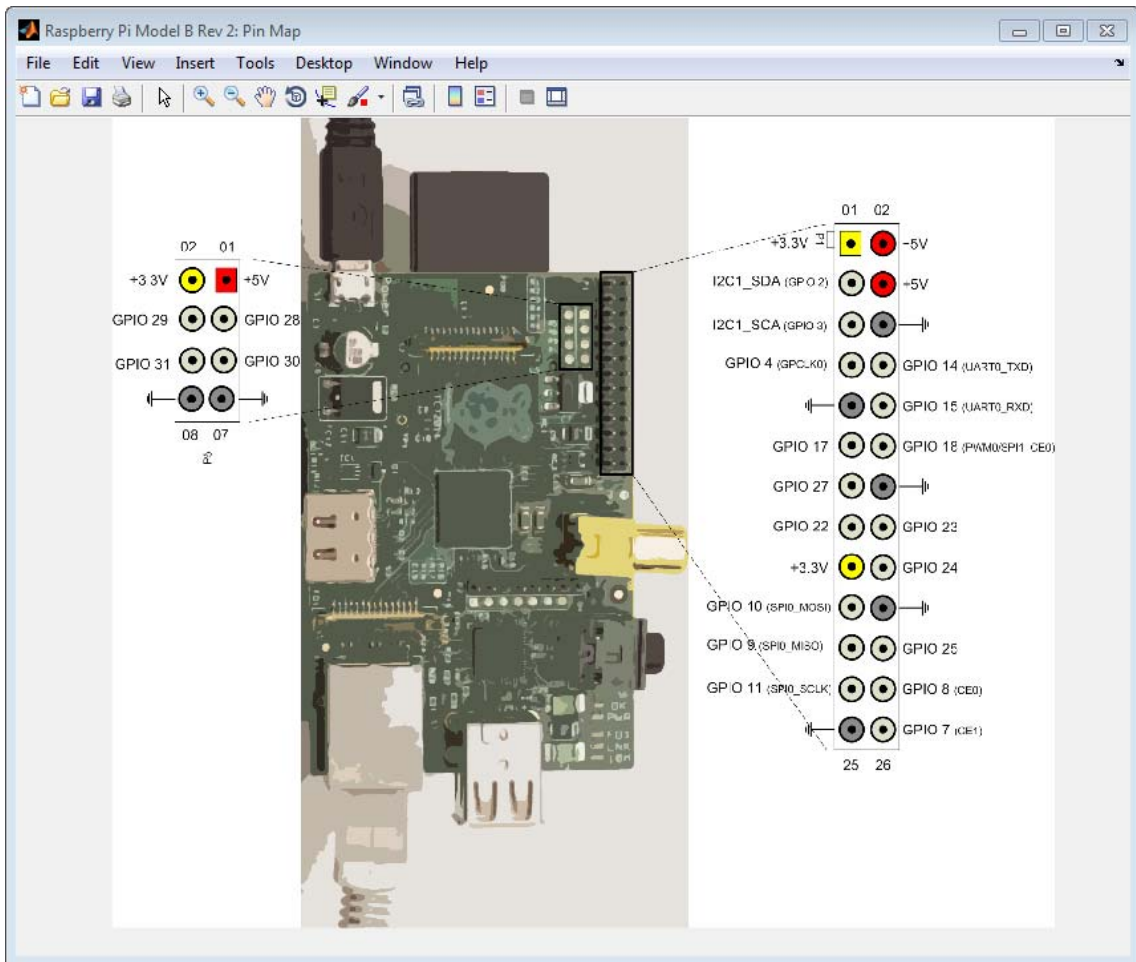

The pin map shows that, for this model and revision of the board, the i2c-1 bus is available on the GPIO header pins I2C1\_SDA (GPIO 2) and I2C1\_SCL (GPIO 3).

After physically connecting your I2C device to the I2C pins, get the addresses of I2C devices attached to the I2C bus, 'i2c-1'.

```
scanI2CBus(mypi, 'i2c-1')
```

```
ans =
```

```
{'0x55', '0x20'}
```

Create a connection to the I2C sensor at '0x20' and assign that connection to a handle, `i2csensor`.

```
i2csensor = i2cdev(mypi, 'i2c-1', '0x20')
```

```
i2csensor =
```

```
I2C with Properties:
```

```
 Bus: i2c-1
```

```
 I2CAddress: 0x20
```

```
 Timeout: 10
```

Read two uint8 numbers from the sensor.

```
output1 = read(i2csensor, 2);
```

Read the value of register 14 from the sensor

```
output2 = readRegister(i2csensor, 14);
```

Create a connection to the I2C LED display at '0x55' and assign that connection to a handle, `i2cdisplay`.

```
i2cdisplay = i2cdev(mypi, 'i2c-1', '0x55')
```

```
i2cdisplay =
```

```
I2C with Properties:
```

```
 Bus: i2c-1
```

```
 I2CAddress: 0x55
```

```
 Timeout: 10
```

Write characters to the display.

```
write(i2cdisplay,[hex2dec('20') hex2dec('51')]);
```

Write a scalar hexadecimal value, `hex2dec('08')`, to register 3 on an I2C device.

```
writeRegister(i2cdisplay,3,hex2dec('08'),'uint8');
```

If you are not using I2C, disable I2C to make additional GPIO pins available.

```
disableI2C(mypi)
```

When you use I2C again, enable I2C.

```
enableI2C(mypi)
```

You can only change the `mypi.I2CBusSpeed` property when you enable I2C.

```
disableI2C(mypi);
enableI2C(mypi,400000);
mypi.I2CBusSpeed
```

```
ans =
```

```
40000
```

## See Also

[i2cdev](#) | [read](#) | [write](#) | [readRegister](#) | [writeRegister](#) | [enableI2C](#) | [disableI2C](#) | [raspi](#) | “Raspberry Pi Hardware”

## Related Examples

- “Open Interactive Examples”

## External Web Sites

- [nxp.com](#) search results for “I2C specification”

# serialdev

---

## Purpose

Create connection to serial device

## Syntax

```
myserialdevice = serialdev(myPi,port)
myserialdevice =
serialdev(myPi,port,baudRate,dataBits,parity,
 stopBits)
```

## Description

`myserialdevice = serialdev(myPi,port)` connects to a serial device and returns a handle, `myserialdevice`. You can use `myserialdevice` to exchange data with the serial device using the read and write methods. You can read and write `myserialdevice` properties such as the baud rate.

On the Raspberry Pi hardware, the `/boot/cmdline.txt` file configures `/dev/ttyAMA0` as the serial device and sets the default baud rate to 115200. The serial device connects to the Rx and Tx pins on the GPIO header.

By default, the serial console in the customized version of Raspian Wheezy on your Raspberry Pi hardware is disabled. To use `serialdev`, the serial console must be disabled.

```
myserialdevice =
serialdev(myPi,port,baudRate,dataBits,parity, stopBits)
connects to a serial device using optional arguments to override the
default values for baud rate, data bits, parity, and stop bits. Specify
values for each argument from left to right. To use default
values, omit the right-most arguments.
```

## Input Arguments

### **myPi - Connection to specific board**

handle

Connection to a specific board, specified as a handle.

Use `raspi` to create this connection.

**Example:** `myPi`

## **port - Serial device path and file name**

serial device

Serial device path and file name, specified as a string.

**Example:**  `'/dev/ttyAMA0'`

### **Data Types**

char

## **baudRate - Serial device baud rate**

115200 (default) | 50 | 75 | 110 | 134 | 150 | 200 | 300 | 600 | 1200 | 1800 | 2400 | 4800 | 9600 | 19200 | 38400 | 57600 | 230400

Serial device baud rate, specified as a scalar. Optional.

**Example:** 9600

### **Data Types**

double

## **dataBits - Data bits per character**

8 (default) | 5 | 6 | 7 | 9

Data bits per character, specified as a scalar. Optional.

**Example:** 8

### **Data Types**

double

## **parity - Parity bit**

'none' (default) | 'odd' | 'even' | 'mark' | 'space'

Parity bit, specified as a string. Optional.

This setting enables and selects the type of parity-bit error detection.

**Example:** `'none'`

### **Data Types**

char

## **stopBits - Stop bits**

1 (default) | 1.5 | 2

Stop bits, specified as a scalar. Optional.

**Example:** 1

## **Data Types**

double

## **Output Arguments**

### **myserialdevice - Connection to specific serial device**

handle

Connection to a specific serial device, specified as a handle.

You can use `myserialdevice` with the following methods:

- `read`
- `write`

You can use `myserialdevice` to read the following properties for the serial device:

- `BaudRate`
- `DataBits`
- `StopBits`
- `Parity`

You can use `myserialdevice` to read and write the `TimeOut` property for the serial device:

## **Examples**

### **Connect and Exchange Data with Serial Device**

You can create a connection to a serial device, write data to the device, and read data from the device.

Create a connection to the Raspberry Pi board.

```
mypi = raspi;
```

Show the location of the Tx and Rx pins, GPIO 14 (UART0\_TXD) and GPIO 15 (UART0\_RXD), on the GPIO header.

```
showPins(myPi)
```

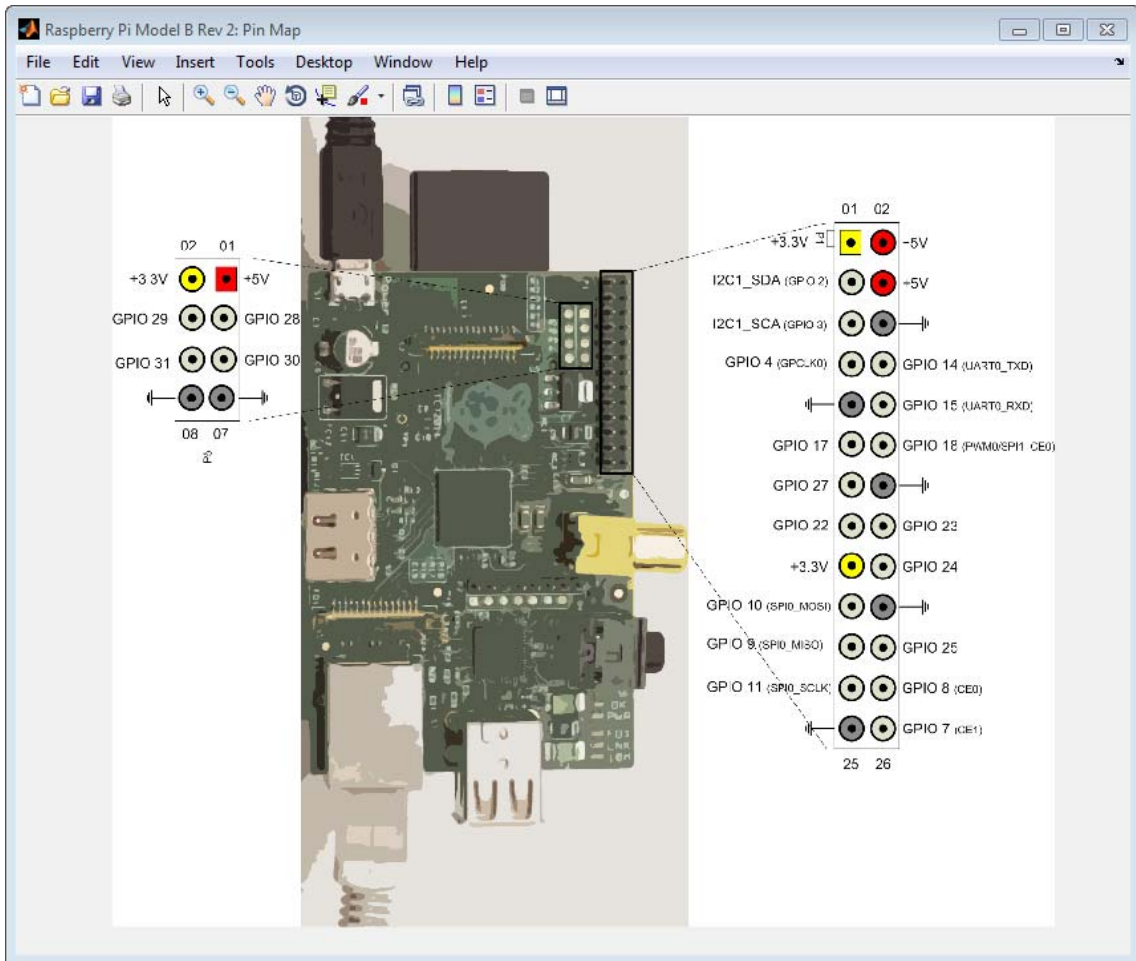

Raspberry Pi hardware uses +3.3V. Do not connect Raspberry Pi hardware directly to devices that use higher voltages.

Connect the Raspberry Pi serial port to a +3.3V serial device.

- To receive data, connect the RXD pin (GPIO 15 UART0\_RXD) on the Raspberry Pi board to the TXD pin on the serial device.
- To transmit data, connect the TXD pin (GPIO 14 UART0\_TXD) on the Raspberry Pi board to the RXD pin on the serial device.
- Connect a ground pins (GND) on the Raspberry Pi board to the GND pin on the serial device.
- Connect one of the +3.3V pins on the Raspberry Pi board to the VCC pin on the serial device.

Research the values the serial device requires for the baud rate, data bits, parity, and stop bit.

Use `serialdev` to create a connection to the serial device and assign the connection to a handle.

```
myserialdevice = serialdev(mypi, '/dev/ttyAMA0', 9600)
```

```
myserialdevice =
```

```
 Serialdev with Properties:
```

```
 BaudRate: 9600
 DataBits: 8
 Parity: 'none'
 StopBits: 1
 Timeout: 10
```

Write a pair of values to a serial device that requires a specific data type.

```
write(myserialdevice, [10 12], 'uint16')
```

Read a 100-element array of numbers from the serial port.

```
output = read(myserialdevice, 100, 'uint16');
```



Increase the timeout period of the serial port.

```
myserialdevice.Timeout = 20
```

```
myserialdevice =
```

```
 Serialdev with Properties:
```

```
 BaudRate: 115200
```

```
 DataBits: 8
```

```
 Parity: 'none'
```

```
 StopBits: 1
```

```
 Timeout: 20
```

## See Also

[read](#) | [write](#) | [showPins](#) | [raspi](#) | “Raspberry Pi Hardware”

## Related Examples

- “Open Interactive Examples”

## External Web Sites

- [http://elinux.org/RPi\\_Serial\\_Connection](http://elinux.org/RPi_Serial_Connection)

# showLEDs

---

**Purpose** Show location, name, and color of user-controllable LEDs

**Syntax** showLEDs(my\_pi)

**Description** showLEDs(my\_pi) displays the location, name, and color of the user-controllable LEDs on the current board.

**Input Arguments** **my\_pi - Connection to specific board**  
handle

Connection to a specific board, specified as a handle.

Use raspi to create this connection.

**Example:** my\_pi

**Examples** **Control the On-Board LED**

You can locate and control the on-board LED, turning it on and off.

Create a connection to the Raspberry Pi board.

```
my_pi = raspi
```

```
my_pi =
```

```
Raspi with Properties:
```

```
 DeviceAddress: 'raspberrypi-computername'
 Port: 18725
 BoardName: 'Raspberry Pi Model B Rev 2'
 AvailableLEDs: {'led0'}
 AvailableDigitalPins: [4 14 15 17 18 22 23 24 25 27 30 31]
 AvailableSPIChannels: {}
 AvailableI2CBuses: {'i2c-0' 'i2c-1'}
 I2CBusSpeed: 100000
```

```
Supported peripherals
```

The `AvailableLEDs` property shows the name of the user-controllable LED.

Show the location of the user-controllable LED on the board.

```
showLEDs(myPi)
```

# showLEDs

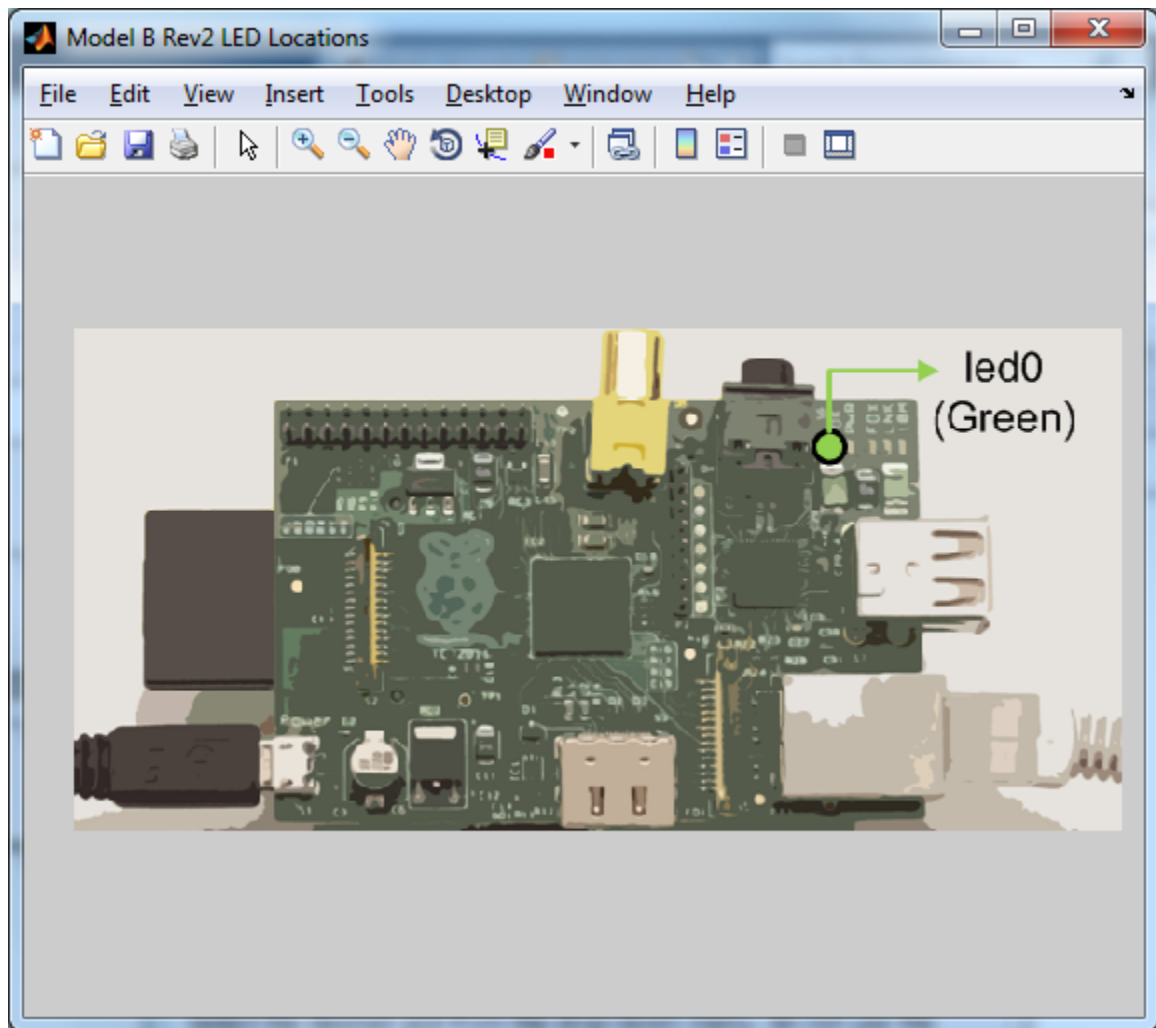

Turn the specified LED on by setting its value to 1 or true.

```
writeLED(mypi, 'led0', 1)
```

Turn the LED off by setting its value to 0 or false.

```
writeLED(mypi, 'led0', false)
```

Rebooting the Raspberry Pi hardware returns the LED to its previous function as an activity indicator.

## See Also

[writeLED | raspi](#) | [showLEDs | raspi](#) | [“Raspberry Pi Hardware”](#)

## Related Examples

- [“Open Interactive Examples”](#)

# showPins

---

**Purpose** Show diagram of GPIO pins

**Syntax** `showPins(myPi)`

**Description** `showPins(myPi)` displays a diagram of the digital input and output pins on the Raspberry Pi hardware. The diagram is a high-resolution MATLAB figure that supports zooming and panning.

**Input Arguments** **myPi - Connection to specific board**  
`handle`

Connection to a specific board, specified as a handle.

Use `raspi` to create this connection.

**Example:** `myPi`

**Examples** **Show a Diagram of Raspberry Pi Pins**

You can display a diagram with the name or purpose and location of each GPIO pin on your Raspberry Pi hardware.

Show the location of the pins.

`showPins(myPi)`

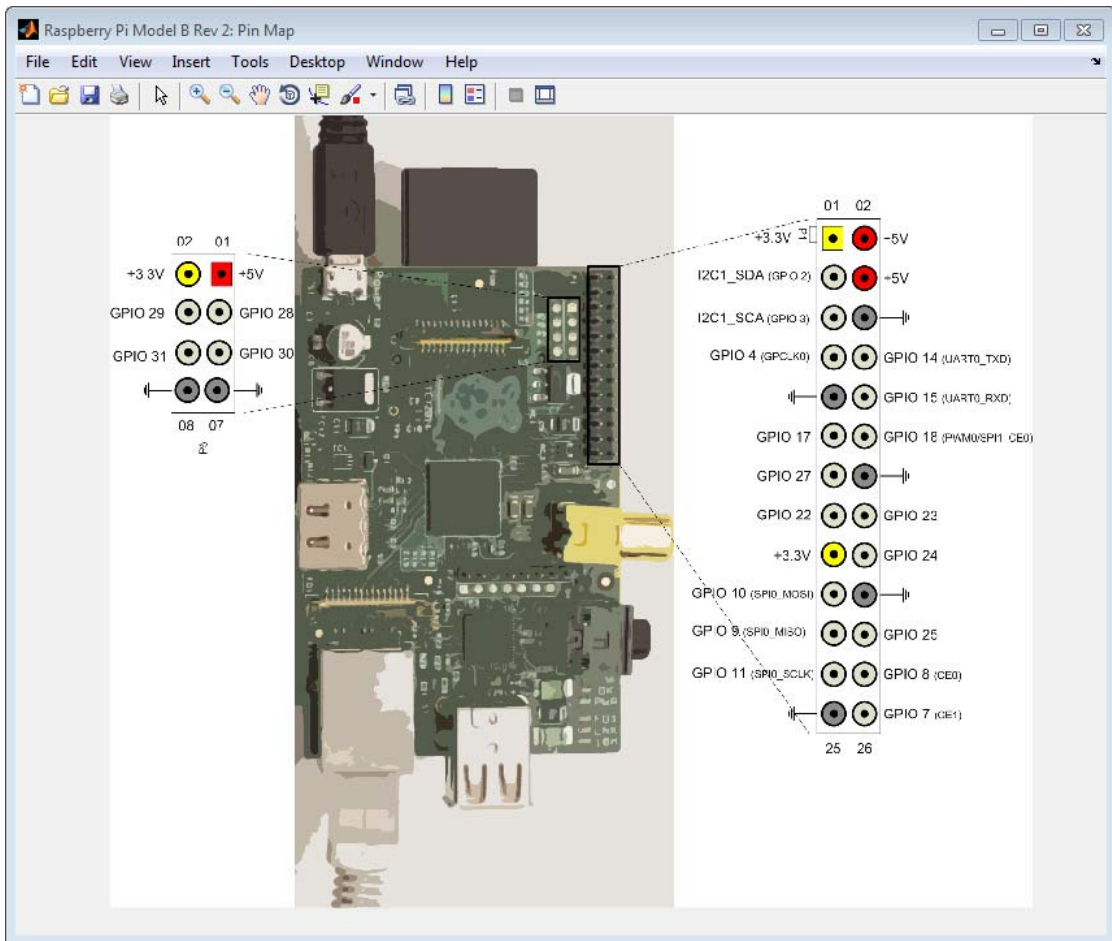

**See Also**

[configureDigitalPin](#) | [readDigitalPin](#) | [writeDigitalPin](#) | [raspi](#) | “Raspberry Pi Hardware”

**Related Examples**

- “Open Interactive Examples”

# snapshot

---

**Purpose** Capture RGB image from Camera Board

**Syntax** `img = snapshot(mycamera)`

**Description** `img = snapshot(mycamera)` returns a still image from the Camera Board in RGB format.

**Input Arguments** **mycamera - Connection to Camera Board**  
`handle`  
Connection to a Camera Board, specified as a handle.  
Use `cameraboard` to create this connection.  
**Example:** `mycam`

**Output Arguments** **img - RGB image**  
RGB image  
RGB image, returned as an n-by-n-by-3 matrix of values.

**Examples** **Use the Camera Board**

You can create a connection to the Camera Board, take a photograph, and record video.

Create a connection to the Raspberry Pi board.

```
mypi = raspi;
```

Create a connection to the Camera Board while changing the resolution, and assign that connection to a handle, `mycam`. The handle displays the Camera Board properties.

```
mycam = cameraboard(mypi, 'Resolution', '1280x720')
```

```
mycam =
```

Cameraboard with Properties:



```

 Name: Camera Board
 Resolution: '1280x720' (View available resolutions)
 Quality: 10 (1 to 100)
 Rotation: 0 (0, 90, 180 or 270)
HorizontalFlip: 0
VerticalFlip: 0
 FrameRate: 30 (2 to 30)
 Recording: 0

Picture Settings
 Brightness: 50 (0 to 100)
 Contrast: 0 (-100 to 100)
 Saturation: 0 (-100 to 100)
 Sharpness: 0 (-100 to 100)

Exposure and AWB
 ExposureMode: 'auto' (View available exposure modes)
 ExposureCompensation: 0 (-10 to 10)
 AWBMode: 'auto' (View available AWB modes)
 MeteringMode: 'average' (View available metering modes)

Effects
 ImageEffect: 'none' (View available image effects)
 VideoStabilization: 'off'
 ROI: [0.00 0.00 1.00 1.00] (0.0 to 1.0 [top, left, width, height])

```

Import and display a sequence of ten snapshots on your host computer.

```

for ii = 1:10
img = snapshot(mycam);
 imagesc(img);
 drawnow;
end

```

If the image is upside down, change the orientation of the image.

```

mycam.Rotation = 180;

```

You can use the same approach to change the values of many mycamera properties listed in the "Name-Value Pair Arguments" for cameraboard.

Record a 60 second video.

```
record(mycam, 'myvideo.mp4', 60)
```

Stop recording before the 60 seconds have elapsed.

```
stop(mycam)
```

Copy the video from the board to your host computer.

```
getFile(myipi, 'myvideo.mp4', 'C:\MATLAB')
```

Delete the video file from the board to free up space.

```
deleteFile(myipi, 'myvideo.mp4')
```

## See Also

[cameraboard](#) | [record](#) | [stop](#) | [getFile](#) | [deleteFile](#) | “Raspberry Pi Hardware”

## Related Examples

- “Open Interactive Examples”

## External Web Sites

- [RaspiCam Documentation](#)

**Purpose**

Create connection to SPI device

**Syntax**

```
mypidevice = spidev(mypi,channel)
mypidevice = spidev(mypi,channel,modespeed)
```

**Description**

`mypidevice = spidev(mypi,channel)` connects to an SPI device and returns a handle, `mypidevice`. You can exchange data with the SPI device by using `mypidevice` with the `writeRead` method. You can use `mypidevice` to read properties of the SPI device.

`mypidevice = spidev(mypi,channel,modespeed)` overrides the default SPI mode, 0, that many SPI devices use.

**Input Arguments****mypi - Connection to specific board**

handle

Connection to a specific board, specified as a handle.

Use `raspi` to create this connection.

**Example:** `mypi`

**channel - SPI channel**

'CE0' | 'CE1'

SPI channel, specified as a string.

**Example:** `'CE1'`

**Data Types**

char

**mode - SPI mode**

0 (default) | 1 | 2 | 3

SPI mode, specified as a scalar. This value determines the clock polarity (CPOL) and phase (CPHA) values.

Mode	CPOL	CPHA
0	0	0
1	0	1
2	1	0
3	1	1

The most common mode is 0.

**Example:** 0

### Data Types

double

### speed - SPI speed

500000 | 1000000 | 2000000 | 4000000 | 8000000 | 16000000 |  
32000000

SPI speed, specified as a scalar.

**Example:** 500000

### Data Types

char

## Output Arguments

### myspidevice - Connection to SPI device

handle

Connection to an SPI device, specified as a handle.

You can use `myspidevice` to exchange data with SPI devices using the `writeRead` method.

You can use `myspidevice` to read the following properties for the SPI connection.

Property Name	Data Type	Dimension	Units
Channel	char	[1,N]	
Mode	double	[1,1]	
BitsPerWord	double	[1,1]	Bits
Speed	double	[1,1]	Clock cycles

## Examples

### Connect and Exchange Data with SPI Devices

You can connect and exchange data with an SPI device.

Create a connection to the Raspberry Pi board.

```
mypi = raspi
```

```
mypi =
```

```
Raspi with Properties:
```

```

 DeviceAddress: 'raspberrypi-computername'
 Port: 18725
 BoardName: 'Raspberry Pi Model B Rev 2'
 AvailableLEDs: {'led0'}
AvailableDigitalPins: [4 7 8 9 10 11 14 15 17 18 22 23 24 25 27 30 31]
AvailableSPIChannels: {}
 AvailableI2CBuses: {'i2c-0' 'i2c-1'}
 I2CBusSpeed: 100000
```

```
Supported peripherals
```

By default, SPI is disabled and `AvailableSPIChannels` does not show any channels.

Enable SPI and get the channels.

```
enableSPI(mypi);
```

```
mypi.AvailableSPIChannels
```

```
ans =
```

```
 'CE0' 'CE1'
```

Show the location of the SPI pins, GPIO 10 (SPI0\_MOSI), GPIO 9 (SPI0\_MISO), and GPIO 11 (SPI0\_SCLK), on the GPIO header.

```
showPins(mypi)
```

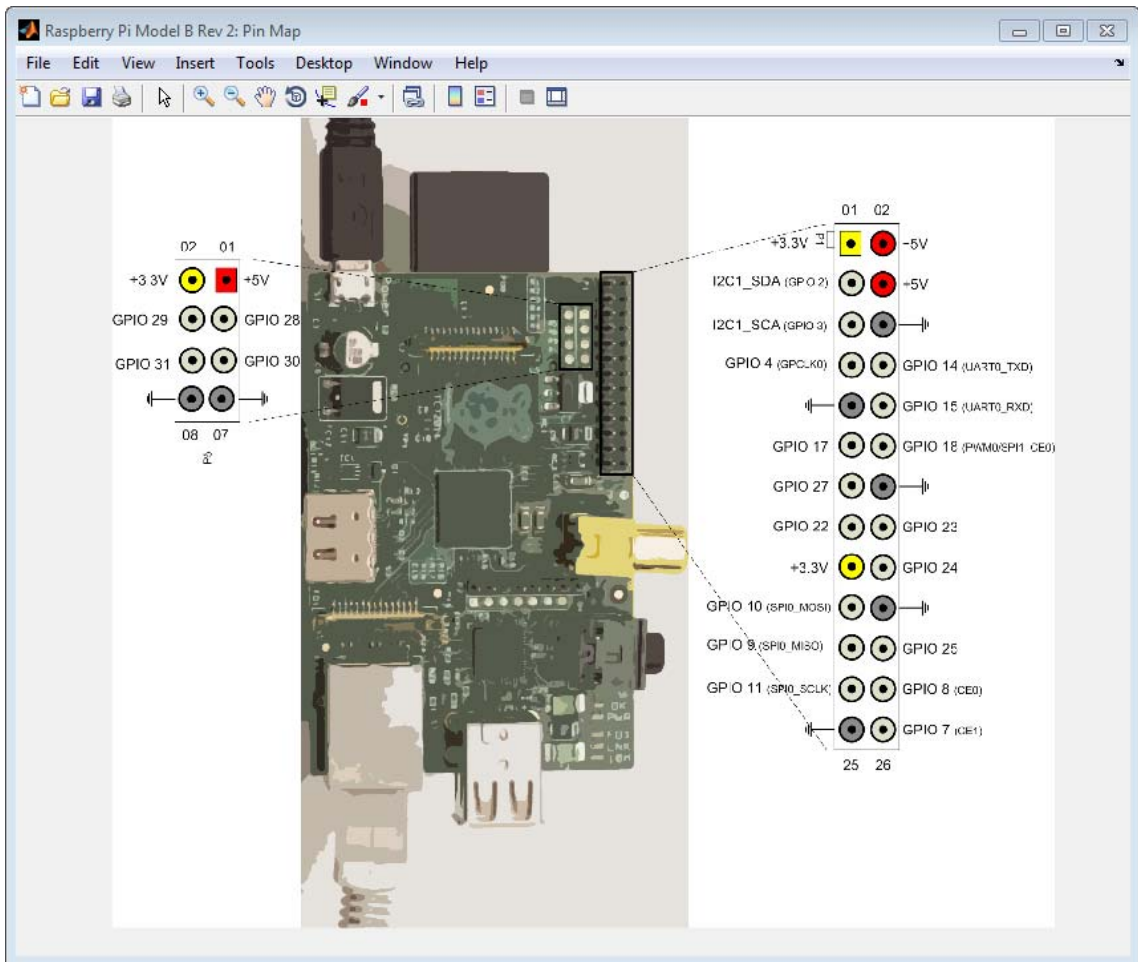

After physically connecting your SPI device to the three SPI pins, connect to the SPI device.

```
myspidevice = spidev(my_pi, 'CE1', 0)
```

```
myspidevice =
```

```
Spidev with Properties:
 Channel: 'CE1'
 Mode: 0
 BitsPerWord: 8
 Speed: 500000
```

Write data to, and read data from, the SPI device.

```
out = writeRead(myspidevice,[hex2dec('08') hex2dec('D4')])
```

```
out =
 7 211
```

If you are not using SPI, disable SPI to make additional GPIO pins available.

```
disableSPI(mypi)
```

## See Also

[raspi](#) | [writeRead](#) | [enableSPI](#) | [disableSPI](#) | “Raspberry Pi Hardware”

## Related Examples

- “Open Interactive Examples”

## External Web Sites

- [en.wikipedia.org/wiki/Serial\\_Peripheral\\_Interface\\_Bus](http://en.wikipedia.org/wiki/Serial_Peripheral_Interface_Bus)



**Purpose** Stop video recording from Camera Board

**Syntax** `stop(mycamera)`

**Description** `stop(mycamera)` stops recording video from the Camera Board.

**Input Arguments**

**mycamera - Connection to Camera Board**  
`handle`

Connection to a Camera Board, specified as a handle.

Use `cameraboard` to create this connection.

**Example:** `mycam`

## Examples Use the Camera Board

You can create a connection to the Camera Board, take a photograph, and record video.

Create a connection to the Raspberry Pi board.

```
mypi = raspi;
```

Create a connection to the Camera Board while changing the resolution, and assign that connection to a handle, `mycam`. The handle displays the Camera Board properties.

```
mycam = cameraboard(mypi, 'Resolution', '1280x720')
```

```
mycam =
```

```
Cameraboard with Properties:
```

```
 Name: Camera Board
Resolution: '1280x720' (View available resolutions)
 Quality: 10 (1 to 100)
 Rotation: 0 (0, 90, 180 or 270)
HorizontalFlip: 0
```

```
VerticalFlip: 0
FrameRate: 30 (2 to 30)
Recording: 0

Picture Settings
Brightness: 50 (0 to 100)
Contrast: 0 (-100 to 100)
Saturation: 0 (-100 to 100)
Sharpness: 0 (-100 to 100)

Exposure and AWB
ExposureMode: 'auto' (View available exposure modes)
ExposureCompensation: 0 (-10 to 10)
AWBMode: 'auto' (View available AWB modes)
MeteringMode: 'average' (View available metering modes)

Effects
ImageEffect: 'none' (View available image effects)
VideoStabilization: 'off'
ROI: [0.00 0.00 1.00 1.00] (0.0 to 1.0 [top, left, width, height])
```

Import and display a sequence of ten snapshots on your host computer.

```
for ii = 1:10
img = snapshot(mycam);
imagesc(img);
drawnow;
end
```

If the image is upside down, change the orientation of the image.

```
mycam.Rotation = 180;
```

You can use the same approach to change the values of many `mycamera` properties listed in the "Name-Value Pair Arguments" for `cameraboard`.

Record a 60 second video.

```
record(mycam, 'myvideo.mp4', 60)
```

Stop recording before the 60 seconds have elapsed.

```
stop(mycam)
```

Copy the video from the board to your host computer.

```
getFile(mypi, 'myvideo.mp4', 'C:\MATLAB')
```

Delete the video file from the board to free up space.

```
deleteFile(mypi, 'myvideo.mp4')
```

## **See Also**

[cameraboard](#) | [snapshot](#) | [record](#) | [getFile](#) | [deleteFile](#) |  
“Raspberry Pi Hardware”

## **Related Examples**

- “Open Interactive Examples”

## **External Web Sites**

- [RaspiCam Documentation](#)

# system

---

<b>Purpose</b>	Run command in Linux shell on Raspberry Pi hardware
<b>Syntax</b>	<code>system(mypi,command)</code> <code>system(mypi,command,sudo)</code>
<b>Description</b>	<p><code>system(mypi,command)</code> runs the command in the Linux command shell on Raspberry Pi hardware.</p> <p><code>system(mypi,command,sudo)</code> runs the command with superuser privileges.</p>
<b>Input Arguments</b>	<p><b>mypi - Connection to specific board</b> handle Connection to a specific board, specified as a handle. Use <code>raspi</code> to create this connection. <b>Example:</b> <code>mypi</code></p> <p><b>command - Linux command</b> command Linux command, specified as string. <b>Example:</b> <code>'ls -al'</code></p> <p><b>sudo - sudo command</b> sudo sudo command, specified as string. <b>Example:</b> <code>'sudo'</code></p> <p><b>Data Types</b> char</p>
<b>Examples</b>	<p><b>Run a Linux Command on the Raspberry Pi Hardware</b> You can run a command that lists the contents of a folder.</p>

```
system(mypi, 'ls -al')
```

```
ans =
```

```
total 100
drwxr-xr-x 10 pi pi 4096 Nov 22 14:18 .
drwxr-xr-x 3 root root 4096 Sep 25 16:22 ..
-rw----- 1 pi pi 21712 Nov 13 17:40 .bash_history
-rw-r--r-- 1 pi pi 220 Sep 25 16:22 .bash_logout
-rw-r--r-- 1 pi pi 3243 Sep 25 16:22 .bashrc
drwxr-xr-x 4 pi pi 4096 Oct 1 18:17 .cache
drwxr-xr-x 6 pi pi 4096 Oct 2 12:01 .config
drwx----- 3 pi pi 4096 Oct 1 18:17 .dbus
drwxr-xr-x 2 pi pi 4096 Nov 13 17:30 Desktop
-rw-r--r-- 1 pi pi 35 Nov 13 17:41 .dmrc
drwx----- 2 pi pi 4096 Oct 1 18:17 .gvfs
drwxr-xr-x 3 pi pi 4096 Oct 2 14:46 MATLAB
-rw-r--r-- 1 pi pi 5781 Feb 3 2013 ocr_pi.png
-rw-r--r-- 1 pi pi 675 Sep 25 16:22 .profile
drwxrwxr-x 2 pi pi 4096 Mar 10 2013 python_games
drwxr-xr-x 8 pi pi 4096 Oct 2 12:41 wiringPi
-rw----- 1 pi pi 66 Nov 13 17:41 .Xauthority
-rw----- 1 pi pi 261 Nov 13 17:41 .xsession-errors
-rw----- 1 pi pi 449 Nov 13 17:40 .xsession-errors.old
```

### Run a Command with Superuser Privileges

You can run a command with superuser privileges.

```
system(mypi, 'cp /etc/network/interfaces int.copy', 'sudo');
```

### See Also

```
openShell
```

### Related Examples

- “Open Interactive Examples”

### External Web Sites

- [http://elinux.org/CLI\\_Spells](http://elinux.org/CLI_Spells)
- [http://linuxcommand.org/learning\\_the\\_shell.php](http://linuxcommand.org/learning_the_shell.php)

# write

---

## Purpose

Write data to I2C device

## Syntax

```
write(myi2cdevice,data,dataPrecision)
```

## Description

`write(myi2cdevice,data,dataPrecision)` writes data to an I2C device.

The write method stops when it finishes writing the specified data to the device, or when the timeout period elapses.

## Input Arguments

### **myi2cdevice - Connection to I2C device**

handle

Connection to I2C device, specified as a handle.

Use `i2cdev` to create this connection.

**Example:** `myi2cdevice`

### **data - Data to write to I2C device**

data

Data to write to I2C device, specified as vector of hexadecimal values.

**Example:** `[hex2dec('20') hex2dec('51')]`

### **Data Types**

`int8` | `int16` | `uint8` | `uint16`

### **dataPrecision - Data precision**

`'uint8 (default)'` | `'int8'` | `'int16'` | `'uint16'`

Data precision, specified as a string. Match the data precision to the size of the register on the device. Optional.

**Example:** `'int16'`

### **Data Types**

`char`

## Examples

### Connect and Exchange Data with I2C Devices

You can connect and exchange data with a pair of I2C devices.

Create a connection to the Raspberry Pi board.

```
mypi = raspi
```

```
mypi =
```

```
Raspi with Properties:
```

```

 DeviceAddress: 'raspberrypi-computername'
 Port: 18725
 BoardName: 'Raspberry Pi Model B Rev 2'
 AvailableLEDs: {'led0'}
 AvailableDigitalPins: [4 7 8 9 10 11 14 15 17 18 22 23 24 25 27 30 31]
 AvailableSPIChannels: {}
 AvailableI2CBuses: {'i2c-0' 'i2c-1'}
 I2CBusSpeed: 100000
```

```
Supported peripherals
```

Redisplay AvailableI2CBuses and I2CBusSpeed.

```
mypi.AvailableI2CBuses
```

```
mypi.I2CBusSpeed
```

```
ans =
```

```
'i2c-0' 'i2c-1'
```

```
ans =
```

```
100000
```

Show the location of the I2C pins.

```
showPins(myPi)
```

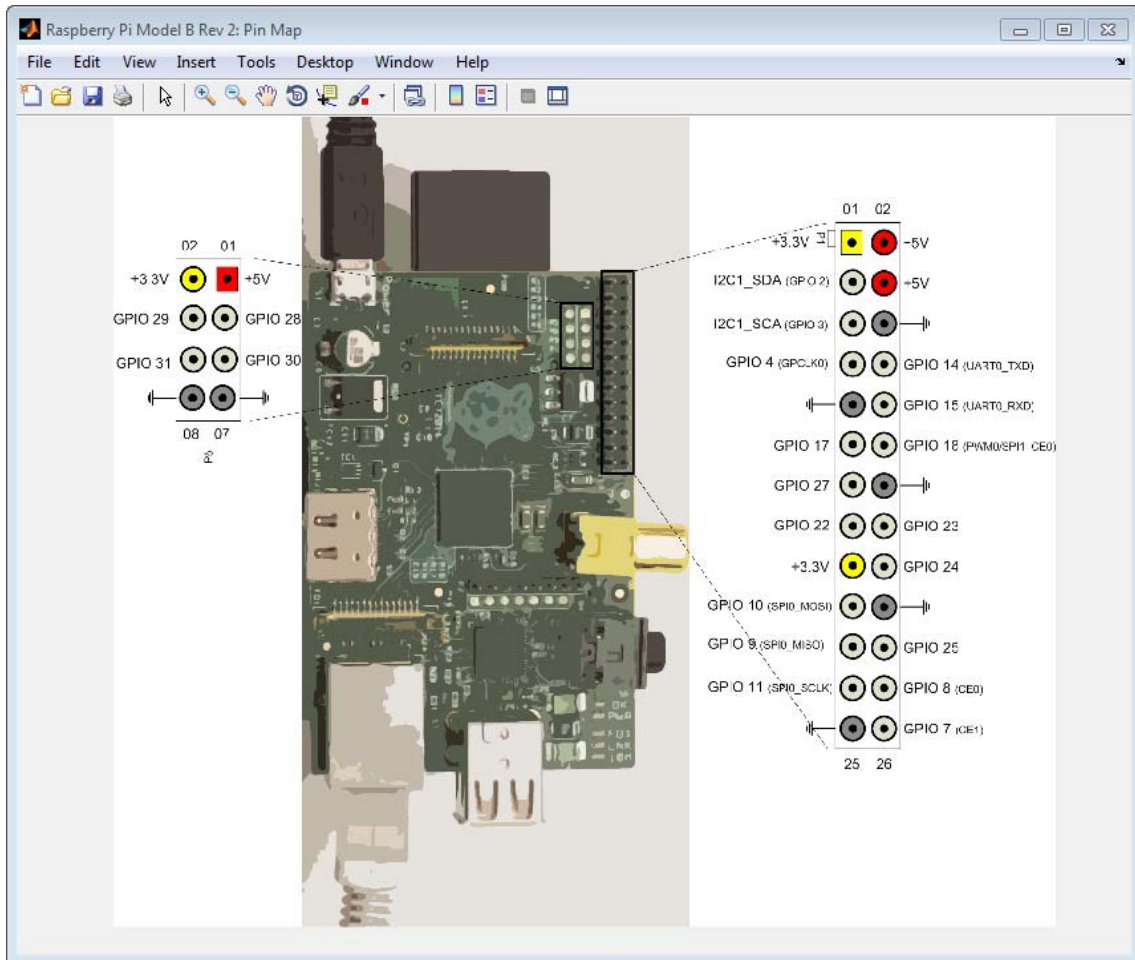

The pin map shows that, for this model and revision of the board, the i2c-1 bus is available on the GPIO header pins I2C1\_SDA (GPIO 2) and I2C1\_SCL (GPIO 3).



After physically connecting your I2C device to the I2C pins, get the addresses of I2C devices attached to the I2C bus, 'i2c-1'.

```
scanI2CBus(mypi, 'i2c-1')
```

```
ans =
```

```
 {'0x55', '0x20'}
```

Create a connection to the I2C sensor at '0x20' and assign that connection to a handle, `i2csensor`.

```
i2csensor = i2cdev(mypi, 'i2c-1', '0x20')
```

```
i2csensor =
```

```
I2C with Properties:
```

```
 Bus: i2c-1
```

```
 I2CAddress: 0x20
```

```
 TimeOut: 10
```

Read two uint8 numbers from the sensor.

```
output1 = read(i2csensor,2);
```

Read the value of register 14 from the sensor

```
output2 = readRegister(i2csensor,14);
```

Create a connection to the I2C LED display at '0x55' and assign that connection to a handle, `i2cdisplay`.

```
i2cdisplay = i2cdev(mypi, 'i2c-1', '0x55')
```

```
i2cdisplay =
```

```
I2C with Properties:
```

```
 Bus: i2c-1
```

# write

---

```
I2CAddress: 0x55
TimeOut: 10
```

Write characters to the display.

```
write(i2cdisplay,[hex2dec('20') hex2dec('51')]);
```

Write a scalar hexadecimal value, `hex2dec('08')`, to register 3 on an I2C device.

```
writeRegister(i2cdisplay,3,hex2dec('08'),'uint8');
```

If you are not using I2C, disable I2C to make additional GPIO pins available.

```
disableI2C(mypi)
```

When you use I2C again, enable I2C.

```
enableI2C(mypi)
```

You can only change the `mypi.I2CBusSpeed` property when you enable I2C.

```
disableI2C(mypi);
enableI2C(mypi,400000);
mypi.I2CBusSpeed
```

```
ans =
```

```
40000
```

## See Also

[scanI2CBus](#) | [i2cdev](#) | [read](#) | [readRegister](#) | [writeRegister](#) | [enableI2C](#) | [disableI2C](#) | “Raspberry Pi Hardware”

## Related Examples

- “Open Interactive Examples”

<b>Purpose</b>	Write data to serial device
<b>Syntax</b>	<code>write(myserialdevice,data,precision)</code>
<b>Description</b>	<code>write(myserialdevice,data,precision)</code> The write method stops when it finishes writing the specified data to the device, or when the timeout period elapses.
<b>Input Arguments</b>	<p><b>myserialdevice - Connection to serial device</b> handle Connection to a serial device, specified as a handle. Use serialdev to create this connection. <b>Example:</b> myserialdevice</p> <p><b>data - Data to write to serial device</b> data Data to write to the serial device, specified as a vector. <b>Example:</b> [10 12]</p> <p><b>Data Types</b> single   double   int8   int16   int32   uint8   uint16   uint32   char</p> <p><b>precision - Data precision</b> 'uint8' (default)   'uint16'   'uint32'   'int8'   'int16'   'int32'   'char' (default)   'single'   'double'</p> <p>Data precision, specified as a string. Optional. <b>Example:</b> 'uint8'</p> <p><b>Data Types</b> char</p>

## Examples

### Connect and Exchange Data with Serial Device

You can create a connection to a serial device, write data to the device, and read data from the device.

Create a connection to the Raspberry Pi board.

```
mypi = raspi;
```

Show the location of the Tx and Rx pins, GPIO 14 (UART0\_TXD) and GPIO 15 (UART0\_RXD), on the GPIO header.

```
showPins(mypi)
```

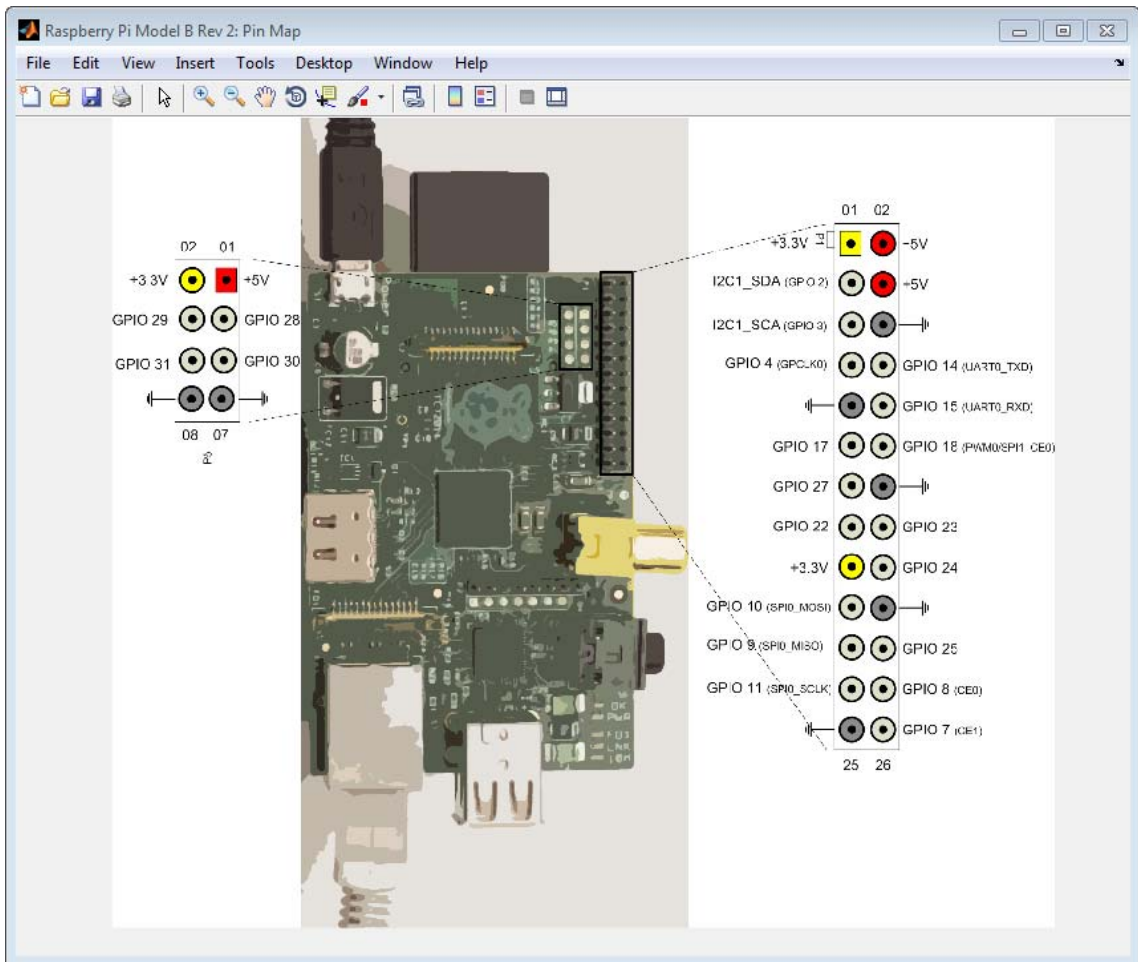

Raspberry Pi hardware uses +3.3V. Do not connect Raspberry Pi hardware directly to devices that use higher voltages.

Connect the Raspberry Pi serial port to a +3.3V serial device.

- To receive data, connect the RXD pin (GPIO 15 UART0\_RXD) on the Raspberry Pi board to the TXD pin on the serial device.

- To transmit data, connect the TXD pin (GPIO 14 UART0\_TXD) on the Raspberry Pi board to the RXD pin on the serial device.
- Connect a ground pins (GND) on the Raspberry Pi board to the GND pin on the serial device.
- Connect one of the +3.3V pins on the Raspberry Pi board to the VCC pin on the serial device.

Research the values the serial device requires for the baud rate, data bits, parity, and stop bit.

Use `serialdev` to create a connection to the serial device and assign the connection to a handle.

```
myserialdevice = serialdev(mypi, '/dev/ttyAMA0', 9600)
```

```
myserialdevice =
```

```
 Serialdev with Properties:
```

```
 BaudRate: 9600
 DataBits: 8
 Parity: 'none'
 StopBits: 1
 Timeout: 10
```

Write a pair of values to a serial device that requires a specific data type.

```
write(myserialdevice, [10 12], 'uint16')
```

Read a 100-element array of numbers from the serial port.

```
output = read(myserialdevice, 100, 'uint16');
```

Increase the timeout period of the serial port.

```
myserialdevice.Timeout = 20
```

```
myserialdevice =
```

Serialdev with Properties:

```
BaudRate: 115200
DataBits: 8
Parity: 'none'
StopBits: 1
Timeout: 20
```

**See Also**

[serialdev](#) | [read](#) | [showPins](#) | “Raspberry Pi Hardware”

**Related Examples**

- “Open Interactive Examples”

# writeDigitalPin

---

**Purpose** Write logical value to GPIO output pin

**Syntax** `writeDigitalPin(myPi, pinNumber, value)`

**Description** `writeDigitalPin(myPi, pinNumber, value)` sets the logical value of a GPIO pin to 0 or 1.

This method configures an unconfigured pin as a GPIO output.

If the pin is a GPIO input, or if another interface (I2C, Serial, SPI) is using the pin, this method returns an error message.

## Input Arguments

### **myPi - Connection to specific board**

handle

Connection to a specific board, specified as a handle.

Use `raspi` to create this connection.

**Example:** `myPi`

### **pinNumber - GPIO pin number**

pin number

GPIO pin number, specified as a scalar. This argument does not accept vectors because the hardware cannot access multiple pins simultaneously.

To get a list of valid pin numbers, enter `myPi.AvailableDigitalPins`.

**Example:** `12`

### **Data Types**

double

### **value - Logical value of pin**

0 | 1

Logical value of the pin, specified as a scalar.

**Example:** `1`



**Data Types**

double | logical

**Examples****Configure Pin as Digital Output and Write Its Logical Value**

You can configure a pin as digital output and write its logical value.

Create a connection to the Raspberry Pi board.

```
mypi = raspi
```

```
mypi =
```

```
Raspi with Properties:
```

```

 DeviceAddress: 'raspberrypi-computername'
 Port: 18725
 BoardName: 'Raspberry Pi Model B Rev 2'
 AvailableLEDs: {'led0'}
AvailableDigitalPins: [4 7 8 9 10 11 14 15 17 18 22 23 24 25 27 30 31]
AvailableSPIChannels: {}
 AvailableI2CBuses: {'i2c-0' 'i2c-1'}
 I2CBusSpeed: 100000
```

The `AvailableDigitalPins` property shows the list of digital pins that are available.

Redisplay `AvailableDigitalPins`.

```
mypi.AvailableDigitalPins
```

```
ans =
```

```
Columns 1 through 13
```

```
 4 7 8 9 10 11 14 15 17 18 22 23 24
```

```
Columns 14 through 17
```

25 27 30 31

Show the location of the GPIO 4.

```
showPins(myPi)
```

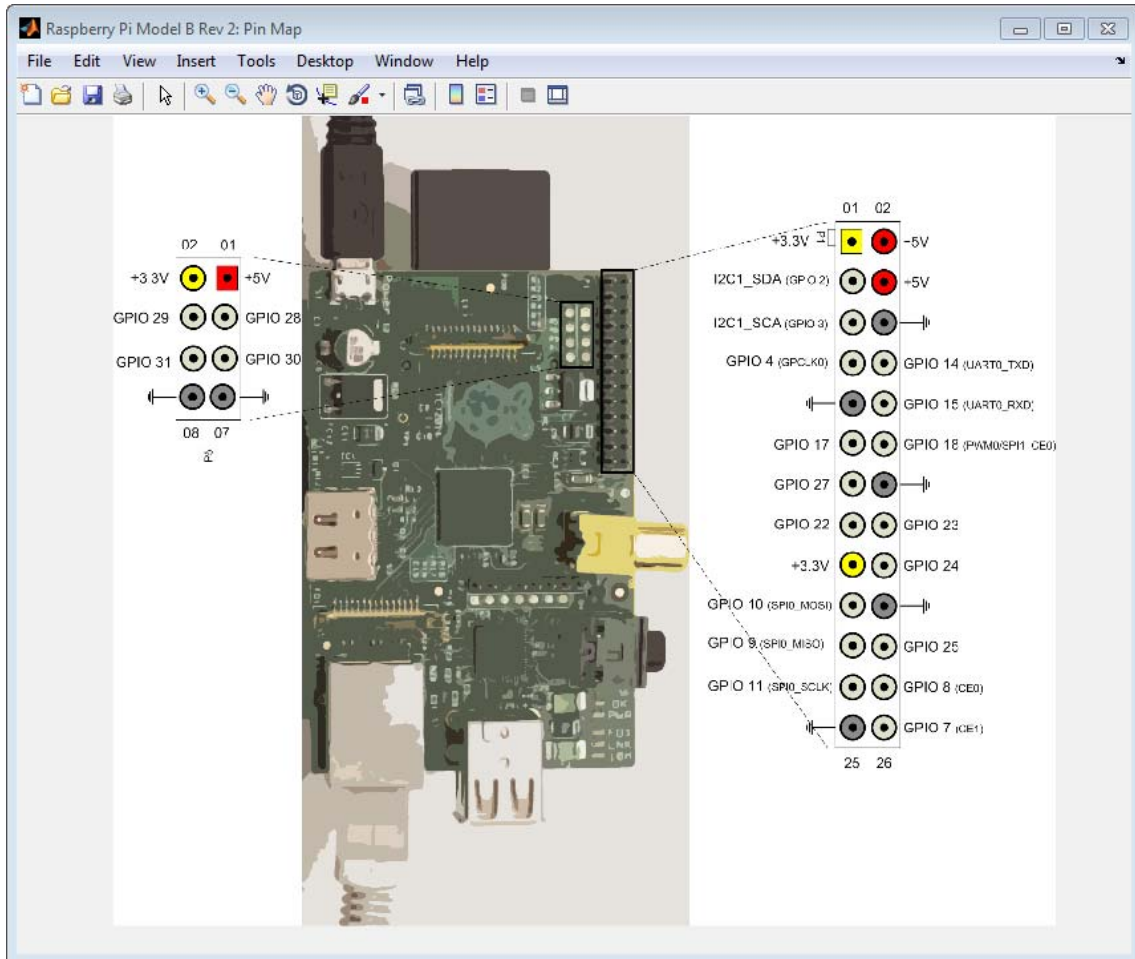

Connect the digital device you are using to GPIO 4.

Configure pin 4 as a digital output.

```
configureDigitalPin(mypi,4,'output')
```

Write a logical value of 1 to pin 4.

```
writeDigitalPin(mypi,4,1)
```

## Pressing a button blinks an LED connected to a GPIO pin

You can press a button to blink an LED connected to a GPIO pin.

This example rapidly blinks an LED when you press a button. The button connects from positive voltage to pin 23. Pressing the button closes the circuit, raising the voltage. When `readDigitalPin` detects the positive voltage, `if buttonPressed` becomes true. The program toggles the voltages to pin 24 on and off ten times. Pin 14 connects to an LED, which connects via a resistor to ground.

```
for ii = 1:100
 buttonPressed = readDigitalPin(mypi,23);
 if buttonPressed
 for jj = 1:10
 writeDigitalPin(mypi,24,1);
 pause(0.05);
 writeDigitalPin(mypi,24,0);
 pause(0.05);
 end
 end
 pause(0.1);
end
```

## See Also

[configureDigitalPin](#) | [readDigitalPin](#) | [showPins](#) | [raspi](#) |  
"Raspberry Pi Hardware"

## Related Examples

- "Open Interactive Examples"

# writeLED

---

**Purpose** Turn LED on or off

**Syntax** `writeLED(mypi,led,value)`

**Description** `writeLED(mypi,led,value)` overrides the default behavior of the LED and turns it on or off.

## Input Arguments

### **mypi - Connection to specific board**

`handle`

Connection to a specific board, specified as a handle.

Use `raspi` to create this connection.

**Example:** `mypi`

### **led - LED name**

`'led0'`

LED name, specified as a string.

To get the name and location of user-controllable LEDs, use `showLEDs`.

**Example:** `'led0'`

### **Data Types**

`char`

### **value - LED off or on**

`0 | 1 | false | true`

LED off or on, specified as a logical value.

**Example:** `0`

### **Data Types**

`logical`

## Examples

### **Control the On-Board LED**

You can locate and control the on-board LED, turning it on and off.

Create a connection to the Raspberry Pi board.

```
mypi = raspi
```

```
mypi =
```

```
Raspi with Properties:
```

```
 DeviceAddress: 'raspberrypi-computername'
 Port: 18725
 BoardName: 'Raspberry Pi Model B Rev 2'
 AvailableLEDs: {'led0'}
AvailableDigitalPins: [4 14 15 17 18 22 23 24 25 27 30 31]
AvailableSPIChannels: {}
 AvailableI2CBuses: {'i2c-0' 'i2c-1'}
 I2CBusSpeed: 100000
```

```
Supported peripherals
```

The `AvailableLEDs` property shows the name of the user-controllable LED.

Show the location of the user-controllable LED on the board.

```
showLEDs(mypi)
```

# writeLED

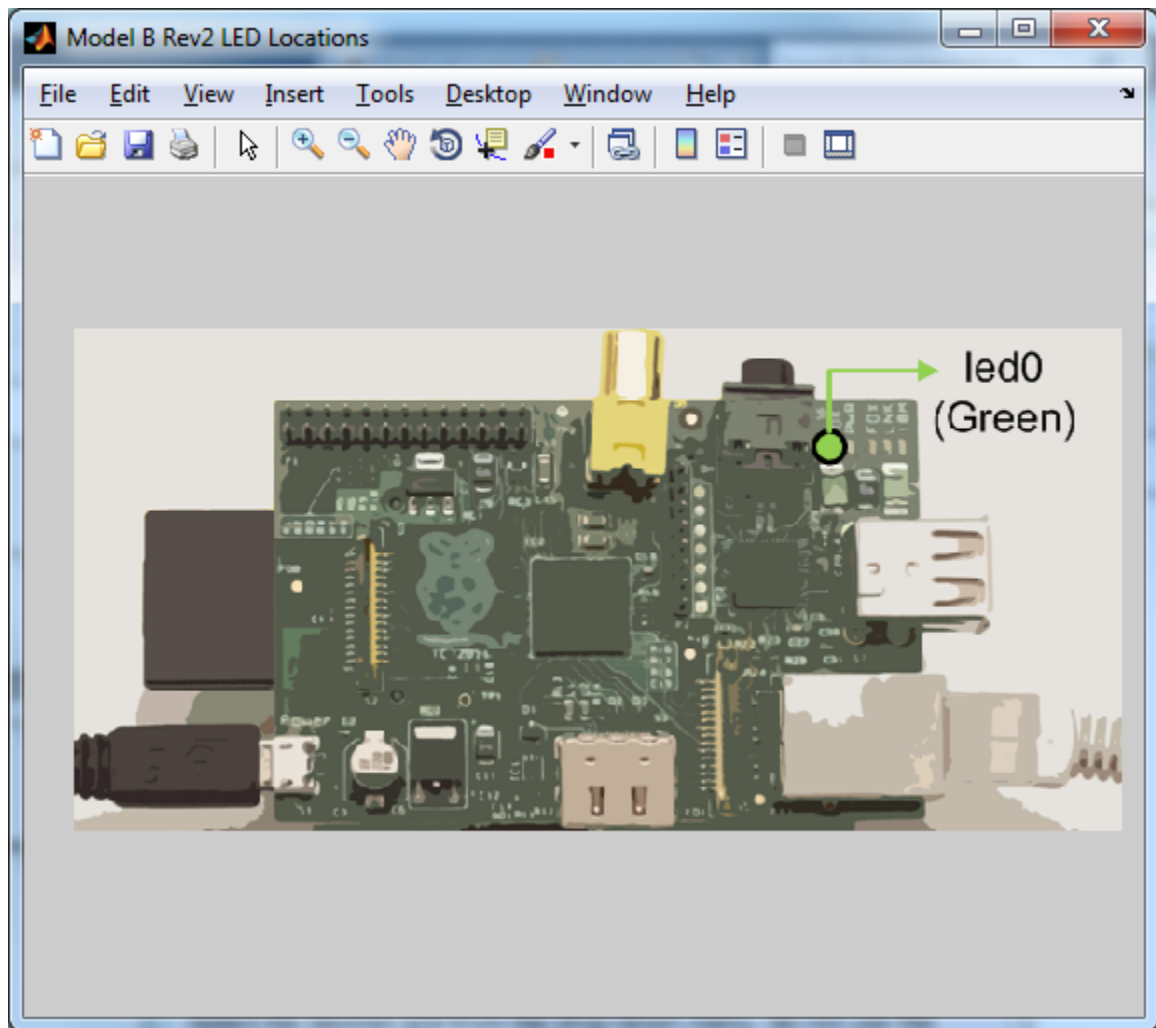

Turn the specified LED on by setting its value to 1 or true.

```
writeLED(mypi, 'led0', 1)
```

Turn the LED off by setting its value to 0 or false.

```
writeLED(mypi, 'led0', false)
```

Rebooting the Raspberry Pi hardware returns the LED to its previous function as an activity indicator.

### Flash the LED in Response to an Input

You can flash the LED in response to an input signal on one of the GPIO pins.

For example, you could use a button and a resistor in series to connect one of the +3.3V outputs to GPIO 23. When you press the button, `readDigitalPin` reads the positive voltage, `if` `buttonPressed` becomes true, and the program flashes the LED ten times.

```
for ii = 1:100
 buttonPressed = readDigitalPin(mypi, 23);
 if buttonPressed
 for jj = 1:10
 writeLED(mypi, 'led0', 1);
 pause(0.05);
 writeLED(mypi, 'led0', 0);
 pause(0.05);
 end
 end
 pause(0.1);
end
```

### See Also

[showLEDs | raspi](#) | “Raspberry Pi Hardware”

### Related Examples

- “Open Interactive Examples”

# writeRead

---

**Purpose** Write data to and read data from SPI device

**Syntax** [outputData] = writeRead(myspidevice,data,dataPrecision)

**Description** [outputData] = writeRead(myspidevice,data,dataPrecision) writes new data to, and reads existing data from, an SPI device.

To read data from an SPI device, you must write data to the device. Supply the `data` argument with the number of values that you expect to read.

The `writeRead` method stops when it finishes writing and reading the specified data from the device.

This method converts data of all other data types to `uint8` for transmission.

## Input Arguments

### **myspidevice - Connection to SPI device**

handle

Connection to an SPI device, specified as a handle.

Use `spidev` to create this connection.

**Example:** `myspidevice`

### **data - Data to write to SPI device**

data

Data to write to the SPI device, or the number of values to read from the SPI device, specified as a vector of hexadecimal values.

**Example:** `[hex2dec('08'), hex2dec('D4')]`

### **Data Types**

`int8` | `int16` | `int32` | `uint8` | `uint16` | `uint32`

### **dataPrecision - Data precision**

`'uint8'` (default) | `'uint16'`

Data precision, specified as a string. Optional.



The `writeRead` method converts data to the data type specified by this argument.

Most SPI devices use `uint8`. Some SPI devices, such as EEPROMs, use `uint16`.

**Example:** `'uint8'`

### Data Types

`char`

## Output Arguments

### **outputData** - Data from SPI device

output data

Data from SPI device, returned as a row vector.

## Examples

### **Connect and Exchange Data with SPI Devices**

You can connect and exchange data with an SPI device.

Create a connection to the Raspberry Pi board.

```
mypi = raspi
```

```
mypi =
```

```
Raspi with Properties:
```

```

 DeviceAddress: 'raspberrypi-computername'
 Port: 18725
 BoardName: 'Raspberry Pi Model B Rev 2'
 AvailableLEDs: {'led0'}
AvailableDigitalPins: [4 7 8 9 10 11 14 15 17 18 22 23 24 25 27 30 31]
AvailableSPIChannels: {}
 AvailableI2CBuses: {'i2c-0' 'i2c-1'}
 I2CBusSpeed: 100000

```

```
Supported peripherals
```

By default, SPI is disabled and `AvailableSPIChannels` does not show any channels.

Enable SPI and get the channels.

```
enableSPI(myPi);
myPi.AvailableSPIChannels
```

```
ans =
```

```
 'CE0' 'CE1'
```

Show the location of the SPI pins, GPIO 10 (SPI0\_MOSI), GPIO 9 (SPI0\_MISO), and GPIO 11 (SPI0\_SCLK), on the GPIO header.

```
showPins(myPi)
```

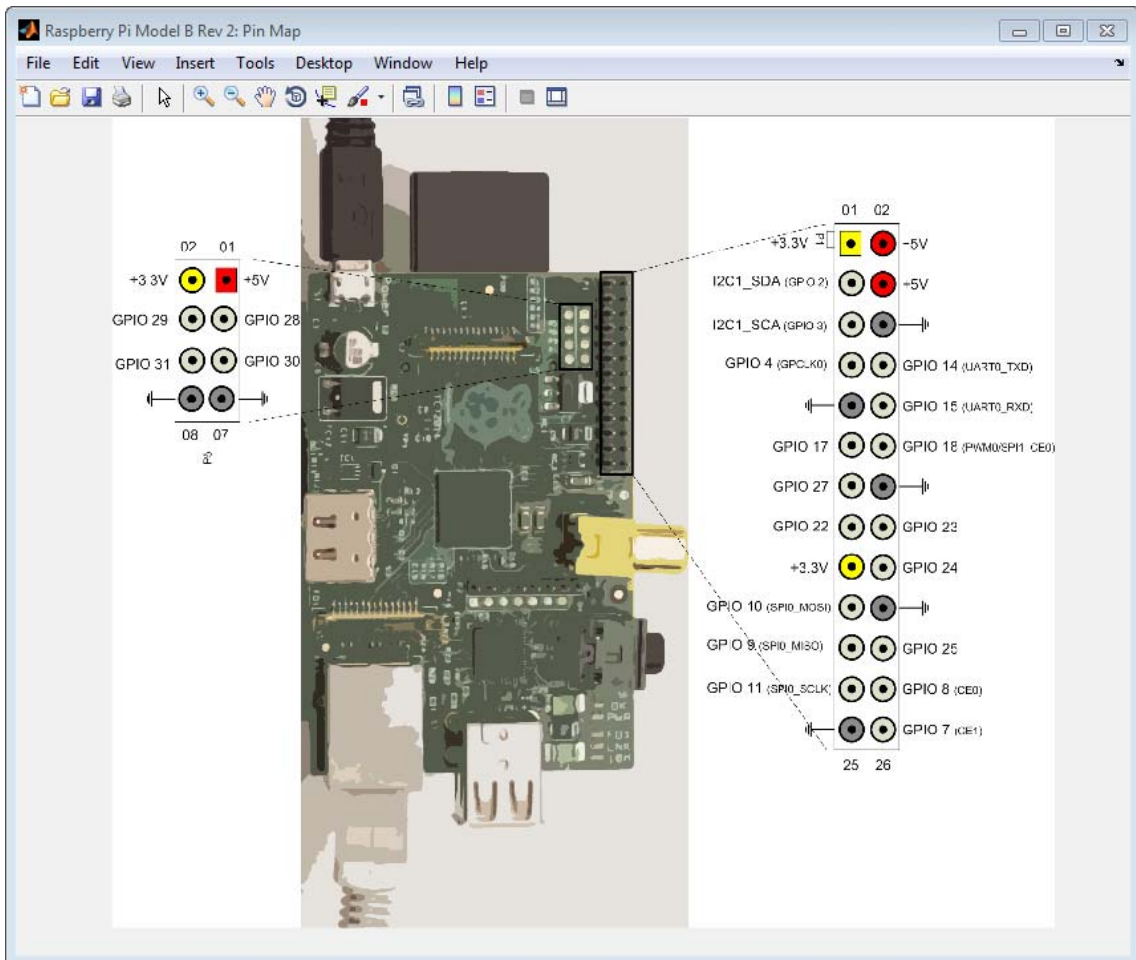

After physically connecting your SPI device to the three SPI pins, connect to the SPI device.

```
myspidevice = spidev(my_pi, 'CE1', 0)
```

```
myspidevice =
```

# writeRead

---

```
Spidev with Properties:
 Channel: 'CE1'
 Mode: 0
 BitsPerWord: 8
 Speed: 500000
```

Write data to, and read data from, the SPI device.

```
out = writeRead(myspidevice,[hex2dec('08') hex2dec('D4')])
```

```
out =
 7 211
```

If you are not using SPI, disable SPI to make additional GPIO pins available.

```
disableSPI(mypi)
```

## See Also

```
raspi | spidev | enableSPI | disableSPI | “Raspberry Pi Hardware”
```

## Related Examples

- “Open Interactive Examples”

<b>Purpose</b>	Write to register on I2C device
<b>Syntax</b>	<code>writeRegister(myi2cdevice, register, value, dataPrecision)</code>
<b>Description</b>	<code>writeRegister(myi2cdevice, register, value, dataPrecision)</code> writes a hexadecimal value to a register on an I2C device. Optionally, you can match the data precision to the size of the register on the device.  The <code>writeRegister</code> method stops when it finishes writing the specified data to the register, or when the timeout period elapses.
<b>Input Arguments</b>	<p><b>myi2cdevice - Connection to I2C device</b> handle Connection to I2C device, specified as a handle. Use <code>i2cdev</code> to create this connection. <b>Example:</b> <code>myi2cdevice</code></p> <p><b>register - I2C register number</b> I2C register number I2C register number, specified as a scalar. This number is available from the device data sheet. <b>Example:</b> <code>14</code></p> <p><b>Data Types</b> double</p> <p><b>value - Numeric value to write to register</b> hexadecimal value Numeric value to write to register, specified as a scalar. (Does not accept arrays.) <b>Example:</b> <code>hex2dec('08')</code></p> <p><b>Data Types</b> <code>int8   int16   uint8   uint16</code></p>

# writeRegister

---

## **dataPrecision - Data precision**

'uint8 (default) | 'int8' | 'int16' | 'uint16'

Data precision, specified as a string. Match the data precision to the size of the register on the device. Optional.

**Example:** 'int16'

## **Data Types**

char

## **Examples**

### **Connect and Exchange Data with I2C Devices**

You can connect and exchange data with a pair of I2C devices.

Create a connection to the Raspberry Pi board.

```
mypi = raspi
```

```
mypi =
```

```
Raspi with Properties:
```

```
 DeviceAddress: 'raspberrypi-computername'
 Port: 18725
 BoardName: 'Raspberry Pi Model B Rev 2'
 AvailableLEDs: {'led0'}
AvailableDigitalPins: [4 7 8 9 10 11 14 15 17 18 22 23 24 25 27 30 31]
AvailableSPIChannels: {}
 AvailableI2CBuses: {'i2c-0' 'i2c-1'}
 I2CBusSpeed: 100000
```

```
Supported peripherals
```

Redisplay AvailableI2CBuses and I2CBusSpeed.

```
mypi.AvailableI2CBuses
```

```
mypi.I2CBusSpeed
```

```
ans =
```

```
'i2c-0' 'i2c-1'
```

```
ans =
```

```
100000
```

Show the location of the I2C pins.

```
showPins(myPi)
```

# writeRegister

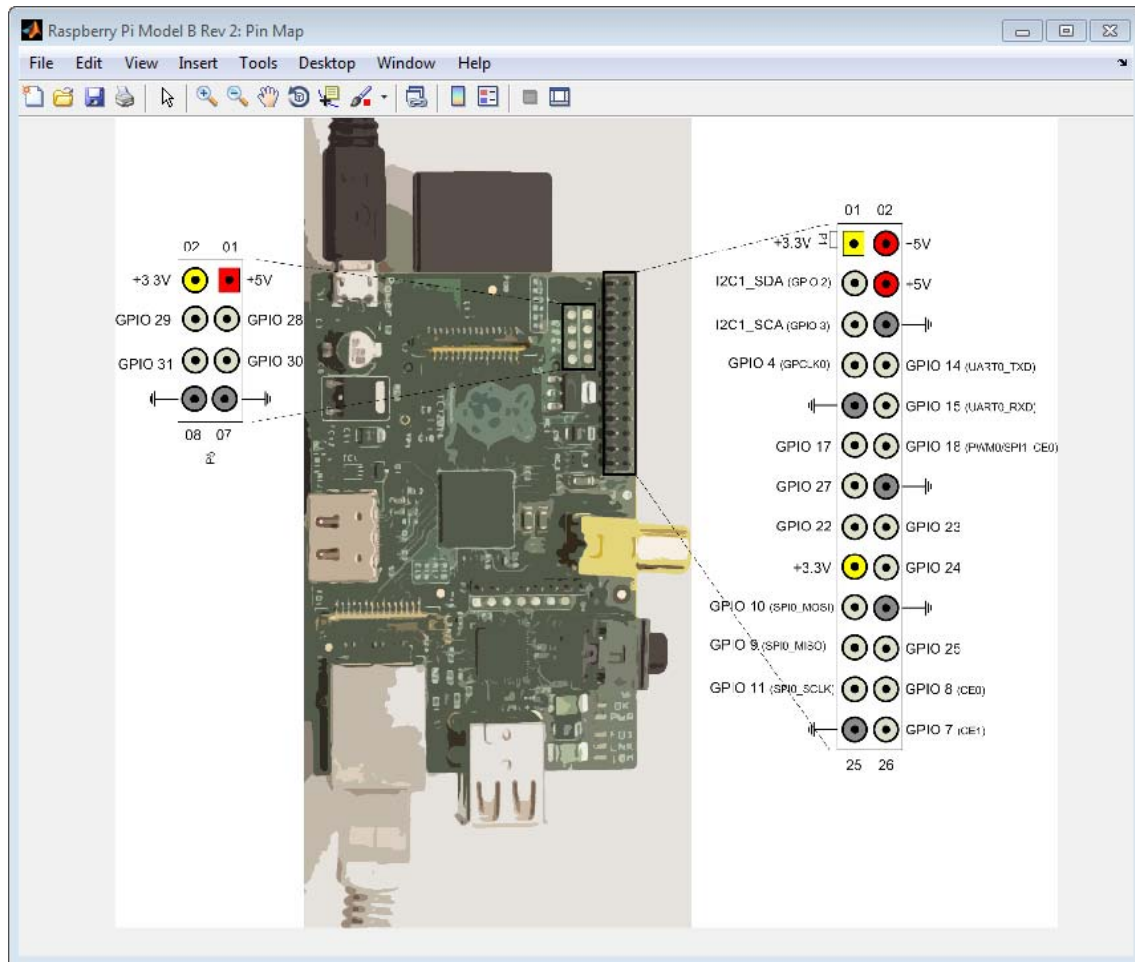

The pin map shows that, for this model and revision of the board, the i2c-1 bus is available on the GPIO header pins I2C1\_SDA (GPIO 2) and I2C1\_SCL (GPIO 3).

After physically connecting your I2C device to the I2C pins, get the addresses of I2C devices attached to the I2C bus, 'i2c-1'.



```
scanI2CBus(mypi, 'i2c-1')
```

```
ans =
```

```
 {'0x55', '0x20'}
```

Create a connection to the I2C sensor at '0x20' and assign that connection to a handle, `i2csensor`.

```
i2csensor = i2cdev(mypi, 'i2c-1', '0x20')
```

```
i2csensor =
```

```
I2C with Properties:
```

```
 Bus: i2c-1
```

```
 I2CAddress: 0x20
```

```
 TimeOut: 10
```

Read two uint8 numbers from the sensor.

```
output1 = read(i2csensor, 2);
```

Read the value of register 14 from the sensor

```
output2 = readRegister(i2csensor, 14);
```

Create a connection to the I2C LED display at '0x55' and assign that connection to a handle, `i2cdisplay`.

```
i2cdisplay = i2cdev(mypi, 'i2c-1', '0x55')
```

```
i2cdisplay =
```

```
I2C with Properties:
```

```
 Bus: i2c-1
```

```
 I2CAddress: 0x55
```

```
 TimeOut: 10
```

# writeRegister

---

Write characters to the display.

```
write(i2cdisplay,[hex2dec('20') hex2dec('51')]);
```

Write a scalar hexadecimal value, `hex2dec('08')`, to register 3 on an I2C device.

```
writeRegister(i2cdisplay,3,hex2dec('08'),'uint8');
```

If you are not using I2C, disable I2C to make additional GPIO pins available.

```
disableI2C(mypi)
```

When you use I2C again, enable I2C.

```
enableI2C(mypi)
```

You can only change the `mypi.I2CBusSpeed` property when you enable I2C.

```
disableI2C(mypi);
enableI2C(mypi,400000);
mypi.I2CBusSpeed
```

```
ans =
```

```
40000
```

## See Also

[scanI2CBus](#) | [i2cdev](#) | [read](#) | [write](#) | [readRegister](#) | [enableI2C](#) | [disableI2C](#) | “Raspberry Pi Hardware”

## Related Examples

- “Open Interactive Examples”

# Functions — Alphabetical List

---

# supportPackageInstaller

---

**Purpose** Find and install support for third-party hardware or software

**Syntax** supportPackageInstaller

**Description** The supportPackageInstaller function opens *Support Package Installer*.

Support Package Installer can install *support packages*, which add support for specific third-party hardware or software to specific MathWorks products.

To see a list of available support packages, run Support Package Installer and advance to the second screen.

You can also start Support Package Installer in one of the following ways:

- On the MATLAB toolstrip, click **Add-Ons > Get Hardware Support Packages**.

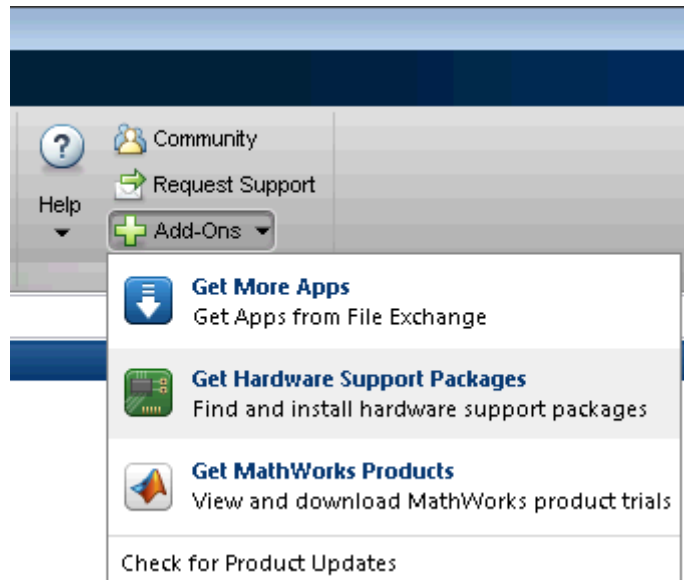

- Double-click a support package installation file (\*.mlpkginstall).

## See Also

`targetUpdater` | `matlabshared.supportpkg.checkForUpdate` |  
`matlabshared.supportpkg.getInstalled`

# targetupdater

---

**Purpose** Open Support Package Installer and update firmware on third-party hardware

## Syntax

**Description** The targetupdater function skips over the support package installation screens and opens Support Package Installer at the “Update firmware” screen. You can use this function to update the firmware on hardware without repeating the support package installation process.

---

**Tip** Use this function when you have multiple pieces of hardware.

---

The targetupdater function is only available for support packages that have already been installed and that require special firmware or setup steps.

If the **Hardware** parameter does not present an option for your hardware, use the supportPackageInstaller function to open Support Package Installer. Support Package Installer will guide you through the process of installing a support package for your hardware and, if required, updating the firmware.

## See Also

supportPackageInstaller |  
matlabshared.supportpkg.checkForUpdate |  
matlabshared.supportpkg.getInstalled

# matlabshared.supportpkg.checkForUpdate

---

## Purpose

Get information about installed support packages

## Syntax

```
matlabshared.supportpkg.checkForUpdate
info = matlabshared.supportpkg.checkForUpdate
```

## Description

`matlabshared.supportpkg.checkForUpdate` displays information about support package updates in the MATLAB Command Window. If an update is available, use `supportPackageInstaller` to install the updates.

`info = matlabshared.supportpkg.checkForUpdate` returns a structured array of information about installed support packages.

## Output Arguments

### **info - Return argument from function**

structure created using `matlabshared.supportpkg.checkForUpdate`

Information about support package updates, returned as a structured array.

## Examples

### **Check for support package updates**

```
matlabshared.supportpkg.checkForUpdate
```

```
No support packages need updates.
```

If one or more updates are available, the command line displays that information in the response.

### **Get a structured array of support package updates**

```
info = matlabshared.supportpkg.checkForUpdate
```

```
info =
```

```
 Name: 'Arduino'
InstalledVersion: '3.0'
 BaseProduct: 'Simulink'
```

# matlabshared.supportpkg.checkForUpdate

---

## See Also

[supportPackageInstaller](#) | [targetUpdater](#) |  
[matlabshared.supportpkg.getInstalled](#)



# matlabshared.supportpkg.getInstalled

---

## Purpose

Get information about installed support packages

## Syntax

```
matlabshared.supportpkg.getInstalled
info = matlabshared.supportpkg.getInstalled
```

## Description

matlabshared.supportpkg.getInstalled displays information about installed support packages in the MATLAB Command Window.

info = matlabshared.supportpkg.getInstalled returns a structured array of information about installed support packages.

## Output Arguments

### info - Return argument from function

structure created using matlabshared.supportpkg.getInstalled

Information about installed support packages, returned as a structured array.

## Examples

### Get a list of installed support packages

```
matlabshared.supportpkg.getInstalled
```

```
Name Version Base Product

Arduino 3.0 Simulink
```

### Get a structured array of installed support packages

```
info = matlabshared.supportpkg.getInstalled
```

```
info =
```

```
 Name: 'Arduino'
InstalledVersion: '3.0'
 BaseProduct: 'Simulink'
```

## See Also

supportPackageInstaller | targetUpdater |  
matlabshared.supportpkg.checkForUpdate